

B WHITE

Division of Mollusks
Sectional Library

46E
652.55
74555
1921
Moll.

DEPARTMENT OF THE INTERIOR

ALBERT B. FALL, Secretary

UNITED STATES GEOLOGICAL SURVEY

GEORGE OTIS SMITH, Director

Professional Paper 129

Division of Geology
Sectional Library

SHORTER CONTRIBUTIONS TO GENERAL GEOLOGY

1921



DAVID WHITE, CHIEF GEOLOGIST



WASHINGTON

GOVERNMENT PRINTING OFFICE

1922

CONTENTS.

[The letters in parentheses preceding the titles are those used to designate the papers for advance publication.]

	Page.
(A) Lithologic subsurface correlation in the "Bend series" of north-central Texas, by M. I. Goldman (published Mar. 7, 1921).....	1
(B) <i>Orthaulax</i> , a Tertiary guide fossil, by C. W. Cooke (published Sept. 29, 1921).....	23
(C) Graphic and mechanical computation of thickness of strata and distance to a stratum, by J. B. Mertie, jr. (published March 14, 1922).....	39
(D) Stratigraphic sections in southwestern Utah and northwestern Arizona, by J. B. Reeside, jr., and Harvey Bassler (published March 22, 1922).....	53
(E) The Byram calcareous marl of Mississippi, by C. W. Cooke (published March 17, 1922).....	79
The Foraminifera of the Byram calcareous marl at Byram, Miss., by J. A. Cushman (published March 17, 1922).....	87
(F) The Foraminifera of the Mint Spring marl member of the Marianna limestone, by J. A. Cushman (published March 28, 1922).....	123
(G) The flora of the Woodbine sand at Arthurs Bluff, Tex., by E. W. Berry (published March 23, 1922).....	153
(H) Geology of the lower Gila region, Ariz., by C. P. Ross (published March 29, 1922).....	183
(I) The flora of the Cheyenne sandstone of Kansas, by E. W. Berry (published April 11, 1922).....	199
Index.....	227

ILLUSTRATIONS.

	Page.
PLATE I. Logs of the Seaman and Rudd wells and a generalized log for north-central Texas	In pocket.
II-V. Species of <i>Orthaulax</i>	33-37
VI. Alinement chart for graphic computation of thickness of strata	44
VII. Alinement chart for graphic computation of depth to a stratum	48
VIII. Alinement chart for graphic solution of right triangles	50
IX. A. Coconino sandstone and Kaibab limestone in Hurricane fault scarp, 6 miles south of Hurricane, Utah; B. Closer view of middle part of scarp shown in A; C. Upper part of Kaibab limestone and basal member (Rock Canyon) of Moenkopi formation in Virgin Canyon, 1½ miles west of Virgin City, Utah	58
X. A. View northward toward Smith's Mesa from a point just south of Virgin City, Utah; B. Panorama along east side of Coalpits Wash near Grafton, Utah	59
XI. A. Chinle formation and overlying massive Jurassic sandstone in Zion Canyon above Springdale, Utah; B. Cross-bedding in white upper part of massive Jurassic sandstone 12 miles north of St. George, Utah	62
XII. A. Group of cinder cones of late date and associated lava, Diamond Valley, 12 miles north of St. George, Utah; B. Nearer view of larger cone of group shown in A	66
XIII. A. Shinarump conglomerate resting on upper Moenkopi shale and sandstone, Smith's Mesa, 3 miles north of Virgin City, Utah; B. Late basalt flow resting on a conglomerate of basalt and other boulders, on road from Toquerville to La Verkin, Utah	67
XIV-XXVIII. Foraminifera of the Byram marl	107-122
XXIX-XXXV. Foraminifera of the Mint Spring calcareous marl	146-152
XXXVI-XL. Fossil plants from the Woodbine sand	181
XL. A. Hills of chloritic schist at the northern end of Big Horn Mountains, near Palo Verde mine, Maricopa County, Ariz.; B. Gonzales Wells, Dome Rock Mountains, Yuma County, Ariz.	184
XLII. A. A plug of latite of Tertiary age in the Dome Rock Mountains, about 4 miles southwest of Quartzsite, Yuma County, Ariz.; B. Black Butte, Cactus Plain, near Osborne's Well, Yuma County, Ariz.	185
XLIII. A. Osborne Wash, about 2 miles southwest of Osborne's Well, Yuma County, Ariz.; B. Saddle Mountain, Maricopa County, Ariz., looking south	188
XLIV. A. Bank of wash near Woolsey Tank, Gila Bend Mountains, Maricopa County, Ariz.; B. Woolsey Tank, Gila Bend Mountains, Maricopa County, Ariz.	189
XLV. Reconnaissance geologic map of the lower Gila region, Ariz.	In pocket.
XLVI. Osage Rock, about 1 mile north of Belvidere, Kans.	202
XLVII-LXI. Fossil plants from the Cheyenne sandstone	225
FIGURE 1. Outline map showing the position of the Seaman and Rudd wells, north-central Texas, and their relation to the "Bend arch"	6
2. Geometric representation of the thickness of a stratum when the dip of the stratum and the relative positions of a point on the upper surface of the stratum and another on the lower surface are given	40
3. Diagram to illustrate the method of calibrating the diagonal scale of a Z chart	43
4. Diagram to illustrate the method of determining the locus of the curvilinear scale in an alinement chart consisting of two parallel straight-line scales and a curvilinear scale	44
5. Geometric representation of the distance to a stratum when the dip of the stratum, the position of a point on the stratum relative to the starting point of measurement, and the horizontal and vertical directions of the line of measurement are given	47
6. Right-angled triangle showing the relations of slope distance, horizontal distance, difference of elevation, and vertical angle between two station points	48
7. Diagram illustrating the combination of three alinement charts for the solution of right-angled triangles	49
8. Diagram illustrating the use of an alinement chart for the solution of the tangent condition in right-angled triangles	50
9. Trigonometric computer for the solution of such problems as are readily solved with the 12-inch straight slide rule	51
10. Map showing localities where sections were measured in Washington County, Utah, and Mohave County, Ariz.	53
11. Cut in the Woodbine sand near Arthurs Bluff, Tex.	180

SHORTER CONTRIBUTIONS TO GENERAL GEOLOGY, 1921.

LITHOLOGIC SUBSURFACE CORRELATION IN THE "BEND SERIES" OF NORTH-CENTRAL TEXAS.

By MARCUS I. GOLDMAN.

OBJECT AND METHODS OF THE INVESTIGATION.

This paper presents the results of an attempt to obtain, by a study of well drillings, criteria for correlation, by the character of the beds encountered, of horizons in the "Bend series" of north-central Texas. The result of the work most directly applicable to the needs of the oil-well operator is that of enabling him to know more exactly the position of the producing beds in his well—a result that is of particular value in north-central Texas because certain beds in that region which give no show of oil to the drill may on being "shot" yield considerable oil. To know the part of the stratigraphic section reached by the drill at any stage of the boring also enables the driller to be on the alert for indications of oil at horizons where productive sands are encountered in other wells and to know when the drill has passed all horizons at which the beds are likely to yield oil.

In two wells that lie near each other the succession of beds is so nearly the same that at least some horizons can be correlated from the driller's logs if they are carefully kept. But the character of any bed may gradually change from place to place, so that the farther apart any two wells are the more difficult it becomes to recognize the beds that lie at the same geologic horizon in them. In undertaking this study, however, I started with the assumption that, though the composition of a bed at a certain horizon in any two widely separated localities might be so different that the bed could not be recognized as such, the relation of its composition to the composition of the beds above and below it would show enough similarity to permit its identification.

That is to say, it seemed probable that any change in the character of the sediment delivered to one part of an open, continuous basin of deposition would be manifested in all other parts of the basin. Thus, an increase of sand would be recorded all over the basin, in one locality perhaps by an increase in the sandiness of a limestone, in another by the deposition of coarse sandstone in the midst of shale, and in still another merely by a slight increase in the amount or the size of sand in a shale, but everywhere there would be an increase in the proportion of sand; and the same rule would apply to the other constituents.¹ To bring this out it was necessary to represent for each sample obtained from a well the proportions of the three principal ingredients—sand, clay, and lime. Lime as here used includes all the transparent carbonates of the calcite group. No attempt to differentiate the several members of that group was made, though the differentiation of calcite and dolomite, for example, would be valuable. The lower limit for size of grain of material classified as sand is about 0.05 millimeter, but this limit is not definite, depending somewhat on factors other than size. If material as fine as 0.02 millimeter were abundant in a thin section it would be estimated as sand, but beds containing material of that fineness are likely to appear essentially as clay.

The most convenient method of compiling the results obtained seemed to be what I have called the "percentage log," shown in the third and fourth columns on Plate I (in pocket).

¹ Though applied much more roughly, this principle is similar to that used by De Geer in correlating the glacial clays of Sweden. See De Geer, Gerard, A geochronology of the last 12,000 years. Cong. geol. internat., II^e sess., Compt. rend., fasc. 1, p. 241, 1910.

In this log the thickness of rocks represented by the sample is laid off vertically to scale as the vertical coordinate. The width of the column represents 100 units, and the percentage of each of the three constituents in each sample—the lime, clay, and sand—is laid off horizontally across the middle of the space representing the sample.²

To obtain these results the samples were examined with a hand lens, which was sometimes supplemented by a binocular microscope. As many types of rock as could be recognized were listed, and the proportion of each was estimated. Fragments of peculiar types and at intervals of the prevailing types were selected to be made into thin sections, which were examined under the compound microscope, and the proportions of sand, clay, and lime in them were estimated. As the work progressed it was found desirable to increase the number of thin sections, even of prevailing types from successive samples, as changes in sandiness might otherwise not be recognized.

The samples examined were obtained from the Seaman well No. 1, in Palo Pinto County, and the Rudd well No. 1, in Comanche County. As those from the Seaman well were the first to be studied the observations on them are somewhat less accurate than those on the Rudd samples.

This method of determining the proportions of the three ingredients is obviously a rather rough one, yet I think it is justified by the results, for it brings out correlations with remarkable detail. It has even certain advantages over the mechanical and chemical analysis employed in the method described by Trager in the paper just cited. Certain changes, especially silicification, which tend to unite the original constituents of the rock so that they can not be separated or which replace them by other substances, interfere, according to the extent to which they are developed, with the correct mechanical or chemical determination of the composition of the rock as it was when deposited, but these changes are not likely to interfere nearly so much with the microscopic recognition of the ingredients, especially of clay and sand. In much chertified beds any

routine mechanical or chemical analysis would seem to be almost useless as a means of determining the original composition. On the other hand, the determination of the proportions of the ingredients by the eye may be very inaccurate, especially in an argillaceous rock, as clay may form a dark stain and veil the presence of other constituents. In work on the black limestones that are so abundant in the "Bend series" there is the added difficulty of distinguishing between organic staining matter and clay. The most accurate method of determining the proportions of the constituents sought would undoubtedly be a combination of observation in thin section with chemical and mechanical analyses, but circumstances did not permit me to use the latter methods. The method used, however, probably does bring out relative composition, which is the essential fact in this investigation.

Where distinct fragments of flint could be recognized in the sample their proportion was estimated and represented separately, merely because they could not properly be classed with the other three constituents. It is my belief that flint is produced by the silicification of sediments after their deposition and that for the purpose of the present investigation it should be regarded as replacing lime.

The flint estimated represents only the proportion of its individual particles, not the degree of silicification of the sample. Incipient chertification was recognized in many thin sections made from samples in which no fragments of flint could be found. In general this microscopic chertification is greater in the lower part of the geologic section, increasing downward as the beds carrying distinct flint are approached. It is therefore not surprising that the highest occurrences of fragments of flint should be at different horizons in the two wells—at 2,738 to 2,745 feet in the Rudd well and at 4,090 to 4,100 feet in the Seaman well.

Although the assumption that variations in the proportions of the principal constituents of these beds would be recorded in widely separated parts of the basin in which they were deposited proved, in a general way, to be remarkably well justified, there is one respect in which it requires restriction and interpretation. It might, indeed, have been expected that lime, which is not a true sedimentary constituent but is mostly of organic origin,

² This method of representation is described by E. A. Trager in A laboratory method for the examination of well cuttings: *Econ. Geology*, vol. 15, pp. 170-176, 1920.

would not conform in detail to this assumption. In a general way, of course, more lime accumulated at certain periods than at others, and in the "Bend series" this fact is most obviously indicated by the subdivision of the series into the Smithwick shale and Marble Falls limestone, though it expresses itself also in detail throughout the series. But the accumulation of lime is much more subject to local conditions than that of sand or clay. Furthermore, lime is not related to depth as simply and regularly as sand and shale. Though there used to be a tendency to assume that limestone represented a deposit in deep, clear water, geologists are now beginning to realize that this assumption applies only to certain kinds of limestone and to certain regions. Most of the mollusks, molluscoids, and echinoids whose remains form the largest part of our limestones lived in water shallow enough to give them their needed light and warmth, though not so near the shore and especially not so near the mouths of rivers that they would be injured by the accumulation of sediment. If a generalization must be made concerning the relation of lime of organic origin to depth it would probably be truer to say that on gently sloping offshore sea bottoms limestones are formed between near-shore detrital deposits, which in many areas include clay, and the deep-sea terrigenous clay deposits, which are fairly well represented by the "blue muds" of the *Challenger* expedition. But this generalization also is subject to many modifications to bring it into accord with local conditions. What is essential for the present purpose is to realize that lime is not likely to vary as regularly from well to well as the true sediments, clay and sand, and that on this account logs representing the proportion of lime will require critical interpretation. The ideal correlation would be one based only on the exact proportions of clay and sand.

The results of my determinations, in addition to being summed up in the percentage log, are represented also in columns 2 and 5 of Plate I (in pocket), in terms of definite lithologic types, in what I have called, for convenience of reference, a "synthetic log." In this log the materials found in each sample are, as far as possible, represented by the usual symbols. It was of course necessary to generalize very much in preparing this log. Obviously, moreover, there is no sure way of determining

the thickness or relative positions, within the interval represented by the samples, of the different types recognized. Where a boundary between two distinct types lies in the interval represented by a sample and such a boundary has been recorded in the driller's log the position given by the driller's log has therefore usually been accepted. In order to bring out some of the more significant thin beds it has been necessary to exaggerate their probable thickness. Finally in column 1 on Plate I (in pocket), is given the usual graphic form of the driller's log of the Seaman well. No driller's log of the Rudd well was available.

The correlation of the percentage logs was aided greatly by the discovery, made in the course of the work, that the more significant breaks in a stratigraphic series are likely to be marked by the occurrence of autochthonous glauconite, in many instances associated with phosphate, directly above the break or rarely more than a foot or two above it. By autochthonous glauconite I mean glauconite formed in place contemporaneously with the bed in which it occurs. The suggestion that glauconite occurs in this association³ was the result of observations in San Saba County, Tex. A thin sand that contains nodules of phosphate and is full of glauconite was found not more than a foot or two above the Ellenburger limestone at several places southwest of San Saba. A little west of Richland Springs, at the contact between a sandy formation believed to be the Strawn and a limestone believed to be the equivalent of one of the limestones occurring at Dennis, south of Millsap, in the "Millsap division" as defined by Cummins, a similar very glauconitic sand containing nodules of phosphate was found. To establish the validity of the generalization that glauconite occurs just above stratigraphic breaks it may be stated in advance that each of the samples in the collections of the United States Geological Survey taken from the base of the "Bend series" in three wells that showed this horizon and that were rather evenly spaced over a distance of 120 miles north of the outcrop contained coarse autochthonous glauconite. As will be seen when the synthetic logs are discussed (see Pl. I), glauconite occurs at horizons other than breaks in the stratigraphic succession, but at nearly all these horizons it differs in

³ Goldman, M. I., Washington Acad. Sci. Jour., vol. 9, p. 502, 1919.

associations and generally in form and character from the glauconite found at the stratigraphic breaks. The latter is usually more abundant, is predominantly coarse (in grains 0.2 to 0.4 millimeter or more, rarely less than 0.15 millimeter in diameter), is less rounded and less regular in shape, is at many stratigraphic breaks fresher, is deeper in color, and is associated with coarse quartz sand, generally somewhat finer than the glauconite, and with very coarse fragments of fossils or with abundant fossils. At some places it fills or penetrates irregularly the skeletons or hollows of the fossil shells. It is commonly accompanied by very abundant sulphide and in many occurrences by fragments or nodules of brown, isotropic phosphate and by a peculiar opaque compact brown substance, supposed to be some form of clay. The glauconite not associated with stratigraphic breaks usually occurs in small, rounded grains, which are scattered through less coarsely fossiliferous limestone or shale and compared with those found at the stratigraphic breaks look as if they were transported and worn forms of them.

The recognition of this association between autochthonous glauconite and stratigraphic breaks is essentially merely an extension and application of the recognition by Cayeux¹ of the connection between beds of phosphate and movements of transgression and regression. In fact, Cayeux begins his paper by calling attention to the association of glauconite and phosphate in the modern deposits of phosphate by which he seeks to explain those of the geologic past.

With such thick beds of glauconite in mind as those, for instance, of the Upper Cretaceous of New Jersey it would appear unreasonable to assert that glauconite occurs only in association with stratigraphic breaks. Apparently the conditions favorable to the formation of glauconite are characteristically associated with periods of maximum emergence or, according to Barrell's definition, with periods of maximum elevation of base-level² but are not limited to this association. Cayeux formulates the law for the Paris Basin that "all the deposits [of phosphate

of lime] of the Upper Cretaceous originated during periods of great disturbances of the equilibrium of the ocean." I would make the corresponding generalization that in the sections I examined autochthonous glauconite occurs in the "Bend series" only within a few feet above stratigraphic breaks or, where there is no break, only in direct association with maximum elevations of base-level.

It must not be concluded that glauconite is merely a shallow-water deposit coextensive with coarse sand and other near-shore deposits. In the section from the Seaman well I have recognized several stratigraphic breaks that are marked merely by sand, without glauconite. What assumptions may be made, then, as to the special conditions favoring the formation of glauconite? Cayeux, in the paper cited, called attention to the fact that modern accumulations of phosphate associated with glauconite occur in areas of the ocean where great destruction of life has been caused by the meeting of a cold and a warm current. But this is, as Cayeux recognized, too local a phenomenon to account for widespread accumulations of dead organisms and is only one of the disturbances of environment that might result from a movement of base-level. Depth of water and other elements of the environment would also change, and a change in any of them might lead to the destruction of life which would result in the formation of phosphate deposits. But I do not think it should be assumed that a change of environment over a wide area, taking place suddenly, causes a general destruction of life. The essential condition seems to me to be that as a result of the disturbances distinct marine environments come into contact without any physical barrier, and organisms passing from one to another encounter unfavorable conditions and perish in large numbers and during a considerable period of time. From this it can be deduced that glauconite deposits associated with a movement of base-level might not be everywhere entirely contemporaneous, though from what follows it will be evident that the time interval between those formed in different parts of an area as a result of a given movement of base-level is not great.

The association of sulphide with sandy beds in this section admits of two interpretations,

¹Cayeux, L., *Genèse des gisements de phosphates de chaux sédimentaires*; Soc. géol. France Bull., 14th s^{er.}, vol. 5, pp. 750-753, 1905.

²Barrell, Joseph, *Rhythms and the measurement of geologic time*; Geol. Soc. America Bull., vol. 28, pp. 778, 783, 1907.

one of which has been offered by Waite and Udden,⁶ who suggest that the sulphide is due to mineralization after deposition, made possible by the porosity of the sandy beds. Though some of the sulphide I found in the coarse, generally more or less sandy basal beds may have been introduced in this way, I am inclined to believe that most of it is formed syngenetically as a product of the same large amounts of decaying organic matter that probably caused the formation of glauconite. This close relation between glauconite and sulphide has been recognized in modern deposits.⁷ The occurrence of sulphide in the glauconitic beds encountered in the two wells here considered appears to be independent of the porosity of the beds. So far as mere impressions can be relied on, the sulphide seems to be as abundant in the dense, argillaceous phases of these beds as in the open, sandy phases. Then, too, it is in several occurrences associated closely with the shells in the beds, filling the tissues of some of them.

On the other hand, I gained the impression that chertification was rather more extensive in some of these coarse basal beds than in beds that lay adjacent to them, a difference which may indicate effects due to circulation, though it may be due merely to the abundance of coarse calcareous fragments in these beds. If due to circulation, this supports the interpretation of Waite and Udden, though it conflicts with their observations. Probably the beds contain both syngenetic and epigenetic sulphide, and though it may be difficult to distinguish these two types a possible means of discrimination may be found in the fact that the sulphide found in material from these wells appears to occur in two forms, one minutely spheroidal, generally gathered into large concretions, the other having sharp crystal faces. These forms may be respectively syngenetic and epigenetic. The problem deserves study, as the differentiation of syngenetic and epigenetic sulphide would help to throw light on the processes of circulation in the rocks.

The classification of the bedding planes that are overlain by glauconite and that mark the boundaries of the units differentiated in this

paper or the determination of their significance as compared with other bedding planes must, I believe, be postponed until many more observations on this subject have been made. Every bedding plane represents a break in sedimentation and is related by a series of innumerable intermediate types to universally recognized "disconformities" and finally to unconformities. Barrell's analysis of stratigraphic breaks⁸ is very illuminating, but their possible causes seem to me so numerous and their possible relations so complex that, until more detailed study has given better ground for differentiation, I prefer to call the boundaries I have indicated merely stratigraphic breaks, without attempting to define the relative order of magnitude of the time intervals they represent. That they are at least "disconformities" of order B-B in Barrell's system⁹ is, I think, unquestionable. In the accompanying plate I have used the wavy line that is generally regarded as symbolizing an unconformity merely because it emphasizes the breaks, without wishing thereby to indicate their significance.

For the same reason that no more specific name has been given to the stratigraphic breaks, the portions of the section separated by the breaks have been called merely stratigraphic units, without an attempt to determine whether they are of the order of members, formations, series, groups, or any other recognized subdivisions. Their variation in lithology and the recognition of most of them so far only underground makes it seem preferable to identify them merely by letters rather than by names.

LOCATION OF WELLS EXAMINED.

In order to give the method adopted for this investigation a thorough test it was desirable that the wells studied should be far apart and that the samples from them should represent a nearly complete section of the "Bend series." In the collections available in the office of the United States Geological Survey these requirements seemed to be fulfilled by samples from two wells of the Roxana Petroleum Corporation—the Seaman No. 1, in Palo Pinto County, and the Rudd No. 1, in northern Comanche County, both of which were drilled into the

⁶ Waite, V. V., and Udden, J. A., Observations on the Bend in Bough No. 1 in Brown County: *Am. Assoc. Petr. Geologists Bull.*, vol. 3, p. 338, 1919.

⁷ Collet, L. W., *Les dépôts marins*, especially pp. 168-172, Paris, Octave Doin, 1908.

⁸ Barrell, Joseph, *op. cit.*, pp. 776-834.

⁹ *Idem*, fig. 5, p. 796.

Ellenburger limestone. The location of these wells is shown on the accompanying map (fig. 1). The distance between them is about 45 miles.

The section in the Seaman well is much thicker and much more sandy than the section in the Rudd well. This accords with the belief that the land mass from which the sediments

DISCUSSION AND CORRELATION OF THE SEAMAN WELL AND THE RUDD WELL.

INTRODUCTION.

The following discussion will concern itself only with the facts brought out in the graphic logs (Pl. I, in pocket) and with additional

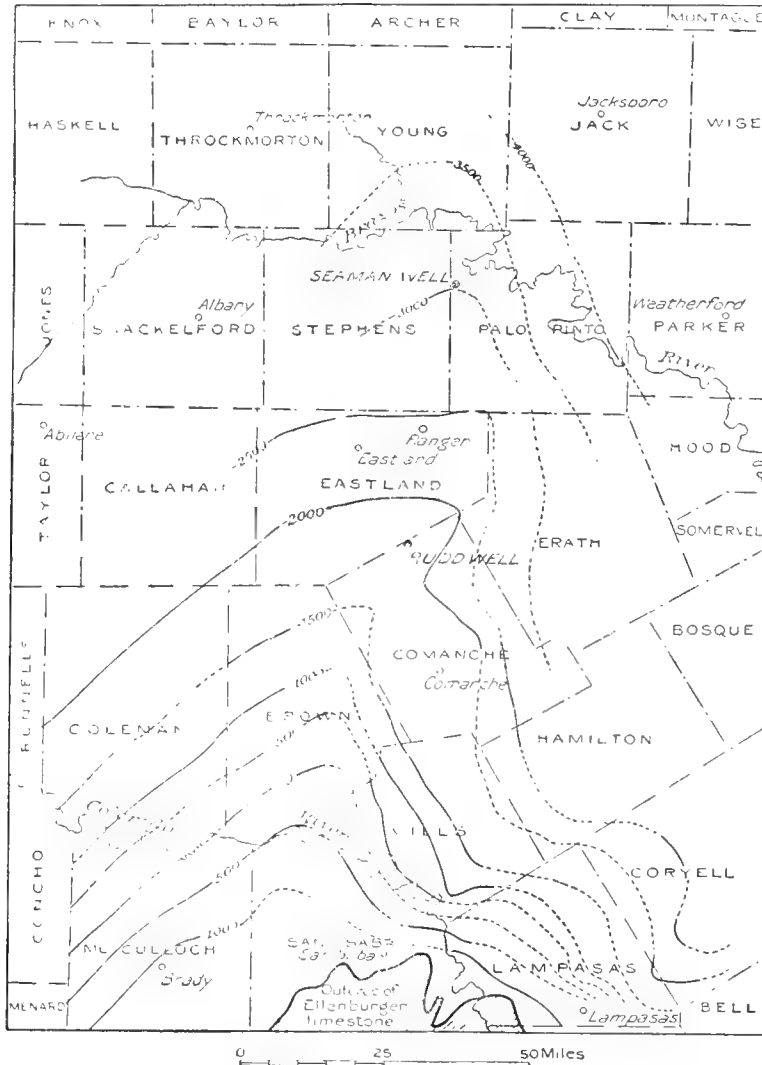

FIGURE 1.—Outline map showing the position of the Seaman and Rudd wells, north-central Texas, and their relation to the "Bend arch." Copied from Texas Univ. Bull. 1849, map facing p. 32, 1918.

of the "Bend series" were derived lay somewhere to the northeast of the north-central Texas area.¹⁰

¹⁰The probable position of this land mass was brought out by F. B. Plummer in a paper read before the American Association of Petroleum Geologists at its meeting in Dallas, Tex., in March, 1919, but in the published version of that paper the only reference I find to it is in the discussion by David White (Am. Assoc. Petr. Geologists Bull., vol. 3, p. 149, 1919). It is also discussed in detail and the literature relating to it is fully reviewed in an article by H. D. Miser, on "Llanoria," to be published in the American Journal of Science.

facts about the lithology that seem important for the correlation but could not be brought out in those logs. For a knowledge of the general character of the beds the reader is referred to the very clear, concise, and well-illustrated paper by Udden and Waite.¹¹

¹¹Udden, J. A., and Waite, V. V., Microscopic characteristics of the Bend and the Ellenburger limestones, 26 pp., mimeographed and illustrated by photographic prints [Austin, Texas Bur. Econ. Geology and Technology, 1919].

The reader is urged to refer constantly to the graphic logs and to make his own detailed comparison of the units in the two wells, especially as they are represented in the percentage logs. To make such a detailed comparison in this paper, with the constant references to depth that would be necessary, would make the discussion too cumbersome, and as the facts are clearly brought out by the graphic logs it seems superfluous.

There are some differences between the two percentage logs that can not be readily explained. They may be due to defects in the observations, especially to the fact that probably too few thin sections of samples from the Seaman well were examined, or to facts that are not in agreement with the general principle on which the correlation is based. Besides, minor variations that are disclosed in the percentage log of the Seaman well may be concealed in the percentage log of the Rudd well owing to the greater thinness of the equivalent section in the Rudd well, so that of two samples representing any given thickness of beds that from the Rudd well generally represents a greater time interval than that from the Seaman well.

The comparison of the units in the two wells will be based on the correlation I have arrived at without at first proving this correlation in each case. This is a necessary result of the principle that the correlation is based not on direct comparison of the lithologic character of two units but on the relation of that character to the character of formations above and below.

UNIT A.

The examination of the material from the Seaman well was begun with material obtained just below the lowest sample that consisted mainly of yellow sand; of that from the Rudd well with the lowest distinctly sandy sample. The percentage logs bring out clearly the sandy character of unit A, which differentiates it unmistakably from the material that lies below it. In and near the basal samples of this unit from both wells were found certain fragments of white sandstone which differed from others in the same samples partly in being more silicified but especially in that one surface, instead of appearing freshly broken like the rest, was dull, gray stained, smoothed, and slightly

pitted, suggesting the surface of a small pebble (half an inch or so in diameter) in a conglomerate. They have been represented in the synthetic log by a conglomerate at the base of unit A.

UNIT B.

In the samples from both wells a difference is immediately noticeable in the character of the shales that directly underlie unit A. They are blacker, less blue-gray than the shales of unit A, much less sandy, more calcareous, and more sulphidic. In shales below unit A sulphides are almost invariably present though in varying abundance.

This unit is too thin in the Rudd well to permit much generalization about its representation in the percentage log, though compared with unit A in that log it is clearly much more calcareous and much less sandy. The much smaller proportion of sand in the Seaman well is also obvious in the percentage log, but the increase of lime is slighter below the contact.

The character of the basal boundary of unit B is very different in the two wells. In the Seaman well it has a feature of special interest brought out in the percentage log—a pronounced, fairly regular increase in sandiness in the upper part of unit C, which reaches a maximum at a depth of 3,045 feet, above which there is a decrease in the amount of sand, also rather regular but more gradual than the increase. The sand appears in sandstones and shales, as represented in a generalized way in the synthetic log. The increase in sandiness of the upper part of unit C may be only apparent, being due to caving of sandy material from unit B in the drill hole, though the large proportion of the sandy material in that part of unit C is very much against this assumption. If the facts are about as represented they may record an ideal boundary between two units. Wherever there is a sharp contact representing a break between two units the sharpness of the contact is due to the fact that the beds representing the time interval between the two units have not been deposited there. Every such break is due to a rise of base-level (the term base-level being used in the sense given to it by Barrell¹²). The true boundary between two formations is the sedimentary surface coinciding

¹² Op. cit., pp. 778, 783.

with the maximum of the oscillation that produced this change of base-level. Some part of the ocean bottom must remain submerged during a rise of base-level, and there the maximum will be recorded in the sedimentary beds. In the Seaman well a surface corresponding to this maximum may be included in the interval represented by the sample from 3,040 to 3,050 feet, in which a maximum of sand would correspond to a maximum of shallowing. For this reason the boundary between units B and C has been placed in the middle of that interval. This boundary is of course not a disconformity and is so represented only for convenience. A name to describe this surface would be useful. The name "akinetic surface" is proposed and defined as the surface in a sedimentary rock which was the outer surface of the lithosphere at some place at the moment an oscillation of base-level at that place passed through its maximum. The word *akinetic* is derived from the Greek word *κινεω*, I move, and the privative prefix *α*. Although the interpretation here given of the boundary between the two formations is a possible interpretation of the observations recorded, it is not inevitable. There may be a considerable time interval, not represented by sediments, between units B and C, and the apparent continuity may be due merely to the reworking of material at the top of unit C into the basal sediments of unit B.

A fact which causes doubt as to the true position of the boundary between units B and C in the Seaman well and points toward its occurrence about the base of the sandstone shown at 3,075 feet is the appearance in the sample from 3,090 to 3,100 feet of shale blacker than any above it and of a type which is distinctly characteristic of unit C. The exact position in this well of the boundary between units B and C within an interval of 30 to 40 feet therefore remains uncertain.

In the Rudd well the boundary is well defined by a typical bed of autochthonous glauconite, with much sulphide, some phosphate nodules, very coarse fossils or fossil fragments, and a little sand.

DIFFERENCE BETWEEN THE SHALES OF UNIT B AND THOSE OF UNIT C.

The prevailing shales of unit B in the Seaman well appear in thin section predominantly

finely granular or felty in appearance, passing where coarser into micaceous and sandy shales. They are of an even brown color and full of brown fragments. These fragments usually increase in coarseness with the coarseness of the sediment, and some of the larger ones can be recognized as fragments of plant matter. Sulphides are common and are largely associated with the plant fragments. The lime in these shales, though locally very abundant, is generally disseminated as a fine dust through the mass.

The prevailing shale of unit C as seen in thin section may be described as of the Marble Falls type—that is to say, the matrix instead of being even and granular has more of a flocculent appearance, being amorphous rather than composed of fine mineral matter. The color is usually a blacker brown and, in correspondence with the flocculent character, is less even than in unit B. Organic matter is undoubtedly abundant but does not appear as definite units but rather as a vague, irregular stain, indistinguishable from the argillaceous matter. Sulphides, though present, are therefore not generally as clearly associated with organic elements as in unit B. Whether there is generally more or less sulphide in unit B or unit C could not be determined by the eye, especially on account of the great difference in the amount of this constituent in different fragments. The determination of the part played by organic matter in these shales and of its relation to the amount and possibly to the manner of occurrence of the sulphide is one of the problems which I hope to take up later. The most distinguishing characteristic of shale of the unit C type is the occurrence in it of lime in coarse irregular fragments and grains, many of them clearly fragments of shells. With the increase of the amount and coarseness of the lime and of the fossil fragments or fossils the shale passes by imperceptible gradations into black limestone¹³ and then into gray limestone. With these differences in microscopic character between the shales of units B and C in the Seaman well goes a difference in their color to the unaided eye. Those of unit B are generally not quite as black as those of unit C, being more of a blue-black. They also usually effervesce less actively in acid.

¹³ See Udden, J. A., and Waite, V. V., Microscopic characteristics of the Bend and the Ellenburger limestones, Texas Bur. Econ. Geology, 1919.

Although these two distinct types of shale are characteristic of units B and C, neither of them is absolutely restricted to its respective unit. Each type is found in smaller amounts in the other unit.

In the Rudd well the microscopic differences between the shales of units B and C are very slight. Sand is not at all abundant in unit B; in the thin sections of many chips there is none. The groundmass of the shales of both units appears equally flocculent. The lime in the shales of unit B is coarsely granular, distinctly not the fine dust that is characteristic of the shale of unit B in the Seaman well. Nevertheless, it is not on the average as coarse as the lime in the directly underlying shales of unit C in the Rudd well, in which a few recognizable coarse fossil fragments are included. Under the hand lens the difference between samples from adjacent parts of the two units is correspondingly slight. These observations on material from the Rudd well are in agreement with the evidence of continuity between the two units in the Seaman well.

DISTINCTION BETWEEN BLACK SHALE AND BLACK LIMESTONE.

From what has been said above of the gradations between black shale and black limestone it follows, as pointed out by many previous workers,¹⁴ that the distinction between black shale and black limestone is more or less arbitrary. In my work I have differentiated them mainly by the appearance of the chips. Angular chips with sharp edges, more or less concave surface, and generally harder appearance I have called limestone. The flatter, more rounded, and more regular chips I have called shale. Where the appearance of the thin section seemed definitely opposed to the classification based on the appearance of the chip I have followed the indications of the thin section. The opinion of the driller, who in addition to seeing the chips knows how the bed drilled, may often be more reliable than an opinion deduced merely from an examination by eye. On the other hand, most drillers appear inclined to generalize the character of a considerable succession of materials. In the synthetic log I have incorporated only my own conclusions, but the facts above set forth should be kept in mind when the synthetic logs are examined and compared with the driller's log.

¹⁴ See Am. Assoc. Petr. Geologists Bull., vol. 3, passim, 1919.

UNITS C AND C'.

In the Seaman well unit C is far from coherent. In the percentage log it appears very irregular. The only generalization that suggests itself is that this unit is distinctly calcareous in the lower part, containing very little sand, but grows sandy toward the top, apparently approaching, more or less by oscillations, the rise of base-level that separates it from unit B. There is more room for considerable difference of opinion about the homogeneity of this unit in the Seaman well than about that of any other unit in the section. If it is to be subdivided, the dividing line would be drawn at 3,320 feet, separating a distinctly sandy and shaly unit above from a succession of black limestones and shales below. To me these two units have not appeared sufficiently distinct, and no glauconite bed was found to indicate a boundary. The correlation with the Rudd well supports this view.

In the Rudd well unit C is very regular and coherent, although it has five sandy zones which may correspond to the five maxima of sand in the Seaman well. If, in accordance with this correlation, the sand between 2,440 and 2,450 feet in the Rudd well corresponds to the sand between 3,440 and 3,450 feet in the Seaman well, the ratio between the part of the section below this sand in the Rudd well compared with the same part of the section in the Seaman well is slightly less than the ratio between the combined units C and C' in the two wells. Thus:

In the Rudd well 2,445 to 2,525 = 80 feet.

In the Seaman well 3,445 to 3,640 = 195 feet.

The ratio is therefore 80 : 195 = 1 : 2.44.

The combined thickness of units C and C' is:

In the Rudd well 2,245 to 2,525 = 280 feet.

In the Seaman well 3,045 to 3,640 = 595 feet.

The ratio is therefore 280 : 595 = 1 : 2.12.

This slight difference may be accounted for by the greater sandiness, implying more rapid deposition, in the upper part of unit C in the Seaman well, as noted above.

In the upper part of this unit there is in both wells a sandstone in the midst of shales—in the Seaman well between 3,180 and 3,190 feet and in the Rudd well between 2,290 and 2,300 feet. In both wells it is largely dark gray, medium grained, and more or less calcareous. In the Seaman well there is, in addition, a very little coarse white sandstone. Similar calcu-

lations for the distance of this sand from the base of unit C' show:

In the Rudd well 2,295 to 2,525 = 230 feet.

In the Seaman well 3,185 to 3,640 = 455 feet.

Ratio 230 : 455 = 1 : 1.98.

The ratio of the distances of the sandstone from the top of unit C is as follows:

In the Rudd well 2,245 to 2,295 = 50 feet.

In the Seaman well 3,045 to 3,185 = 140 feet.

Ratio 50 : 140 = 1 : 2.8.

The much closer agreement of the ratio of distance from the base of unit C' than the ratio of the distance from the top of unit C with the ratio of the total thickness of the combined units in the two wells may indicate that the upper boundary is placed too high in the Seaman well. If the boundary between 3,070 and 3,080 feet in the Seaman well is chosen, then 3,075 to 3,185 = 110 feet, and the ratio becomes 50 : 110 = 1 : 2.2—that is, the ratio from the top is almost identical with the ratio of the total thicknesses. But in view of the much more sandy deposition in the top of unit C in the Seaman well than in the Rudd well this agreement seems to me as much of an argument against accepting the lower boundary as favorable to it. Moreover, as the upper boundaries of units are supposed to correspond to more pronounced disturbances or interruptions of sedimentation, it is in general to be expected that the ratios of intervals from any bed in the unit to the top of the unit will be less regular than those of intervals from the same bed to the base of the unit.

One of the striking instances of parallelism between the percentage logs of the two wells is the similarity in the relations of unit C' in both wells. Unfortunately the samples from 2,480 to 2,490 feet, from 2,500 to 2,510 feet, and from 2,522 to 2,546 feet in the Rudd well are missing, but there are enough samples to indicate that the beds in both wells a little above the base of unit C' record a sudden invasion of a very sandy facies overlying a thin layer of deeper-water sediments and immediately overlain by sediments that were probably laid down in still deeper water. In the Seaman well the base of unit C' is marked by a very typically developed glauconitic basal bed, more phosphatic than usual, almost exactly similar material marks the base of unit C, and between the two is a sharply defined very sandy layer. In the Rudd well the base of unit C' is also marked by a glau-

conite and phosphate layer, and a very sandy black limestone between 2,490 and 2,500 feet appears to represent the sandy layer, but a distinct base for unit C was not located. About 80 per cent of the sample from 2,490 to 2,500 feet is a rather coarsely sandy, coarsely calcareous glauconitic and phosphatic black limestone or shale, but all the fragments examined appeared to have been formed above a basal bed rather than as an actual basal bed. In addition there were considerable traces of coarse quartz sand (1 millimeter or more in diameter). Evidently a basal bed of unit C is present, but from the evidence summarized above it can not be precisely located. The basal beds of units C and C' in the Seaman well were the only ones not noted in the original examination, probably on account of the black color given to the fragments by the phosphatic material, which seems to veil the glauconite. For this reason and on account of the incomplete record in the Rudd well unit C' has been treated as essentially a part of unit C.

The respective depth relations of shale and limestone discussed above (p. 3) are probably well illustrated by a comparison of the composition of units C and C' in the two wells. The Rudd well is in deeper-water deposits, and the large amount of lime in the lower part of unit C in the Seaman well has its equivalent in an exceptionally large amount of almost sand-free clay in the Rudd well. Lime is more abundant in the upper part of unit C in the Rudd well, corresponding to the shallowing indicated by the large amount of sand in the upper part of unit C in the Seaman well, and the shallowing at the base indicated by the sand between 3,610 and 3,630 feet in the Seaman well is represented by sandy black limestone in the midst of shales in the Rudd well.

UNIT D.

Unit D perhaps more clearly than any other unit in the two wells is correlated by the relation of its composition as illustrated in the percentage log to the composition of the units above and below it. In the percentage logs of both wells it stands out as a sharply defined unit, more argillaceous than the units below it and differing distinctly in the proportion of clay from the unit above it. It is in both more sandy and therefore was probably formed in shallower water than most of the lower part of

unit C, and thus it affords one of the chief confirmations of the principle assumed above (p. 3) to govern in a general way the relation of clay and lime. In the Seaman well it was deposited nearer shore and is therefore less calcareous than the lower part of unit C. In the Rudd well also it was laid down nearer shore and is therefore more calcareous than the apparently deep-water shales of the lower part of unit C. In the Rudd well unit D is distinguished throughout by the abundance of calcareous spicules, a characteristic of the Marble Falls limestone.¹⁵ In the Seaman well this characteristic was not noted in unit D, which is probably too argillaceous and sandy.

Although this is the highest unit to show abundant spicular limestones and shales it does not represent the highest horizon at which they appear. In the material from the Rudd well they were first noted, though in small amount, in the sample from 2,490 to 2,500 feet, and in that from the Seaman well in the sample from 3,210 to 3,220 feet, but in these higher occurrences they were of a narrower type than those in unit D in the Rudd well.

The base of unit D in the Seaman well is marked by a typically developed glauconite bed with coarse quartz sand, coarse fossil fragments, phosphate grains, and abundant sulphides. In the Rudd well, on the contrary, though the lithologic difference on the two sides of the boundary is sharp, the basal phase of unit D does not appear pronounced. All that was noted was a small amount of sulphidic black limestone or shale, a few coarse quartz grains, and a very few fragments of black shale or limestone with glauconite grains and coarse fossil fragments.

UNITS E, F, AND G.

The rocks between the base of unit D and the top of unit J fall naturally into two groups, which will be treated as such in the following discussion. The higher of these groups consists of units E, F, and G, which together are characterized by abundant lime deposits with minor detrital accumulations.

The most striking fact about this group of units is the great irregularity of the ratios of thickness between the units in the two wells (see graphic logs, Pl. I, in pocket, and table,

p. 17) and yet their close similarity in details of lithologic succession, as brought out both in the percentage logs and in the synthetic logs. Another characteristic is the thinness of some of the members and the rather poor definition of some of their boundaries, especially as regards the development of glauconite.

The irregular ratios of thickness of the units may be explained by differences in the amount of erosion in the two localities before the formation of each next higher unit. The greatest departure from the prevailing ratios between corresponding units in the two wells is shown by unit E and may indicate that the unconformity at the top of that unit represents a particularly long time interval. This inference is in harmony with the very characteristic development of the basal glauconite bed of unit D and with the pronounced distinctness of unit D from the underlying units, as shown in the percentage log. Another possible interpretation is difference in the rate of accumulation of the beds in the regions of the two wells. Unit E is mainly limestone and therefore, not being primarily detrital, might have accumulated faster in the deeper water of the region of the Rudd well than the combined detrital and calcareous material in the region of the Seaman well.

The composition of unit E calls for little special discussion. There is close parallelism in the succession of its components in the two wells—at the top a thin layer of purer limestone, then a thin more argillaceous layer, and finally purer limestone nearly to the base. In the Seaman well the first typical spicule limestone or shale was noted in the sample from 3,790 to 3,800 feet.

The first gray limestone in the Seaman well appears at the top of unit F. The strong development of sandy and argillaceous deposition at the base of this unit is brought out in striking parallelism in the two percentage logs. The sample from the base of this unit in the Rudd well contained a small fragment consisting of sand loosely bound by a brown substance, believed to be oil.

Unit G is most striking on account of its great difference in thickness in the two wells, yet its two main lithologic members, the calcareous one in the lower part and the argillaceous one in the upper part, are represented in both

¹⁵ Cf. Udden, J. A., and Waite, V. V., *op. cit.*, pp. 16-19.

wells. In the Seaman well sample from 3,960 to 3,970 feet occurs a peculiar white to light-brown or gray shale with minute brown-black spherules, 0.1 to 0.2 millimeter in diameter. Under the microscope the material is seen to be very finely micaceous or sericitic, with varying amounts of rather coarse sand. The spherules are brown to almost opaque, are weakly birefringent, and have a vaguely radial structure, in some surrounded by a concentric shell of similar substance. At the center of many of them is a small sulphide concretion. They are insoluble in nitric acid, and no test for phosphorus could be obtained after fusing them with sodium carbonate. It is hoped later to determine their nature. Some of the features of the matrix suggest a volcanic origin, but no volcanic glass or unusual numbers of heavy minerals were noted on microscopic inspection. Material of this general type, much of it merely white shale without black spherules, was found distributed through the section in the Seaman well from this uppermost occurrence in the sample from 3,960 to 3,970 feet to fragments in the sample from 4,165 to 4,180 feet—that is, in units G, H, I, and J. This distribution without regard to lithologic facies or apparently to any clear boundary is one of the factors favoring the belief in a volcanic origin. In the Rudd well the only distinct occurrence noted was in unit H between 2,780 and 2,790 feet.

The only show of oil recorded in the driller's log of the Seaman well is in unit G in the interval between 3,960 and 4,010 feet, but the exact depth is not given. The horizon at which it would seem most likely to occur would be that of the coarse glauconitic basal sandstone of unit G, just below 4,010 feet, which, as indicated in the generalized log (column 6, Pl. I) is believed to be the equivalent of the Ranger sand.

UNITS H AND I.

Units H and I are grouped together because they stand out clearly from the units above and below them by being more argillaceous and generally containing more detrital material. In the percentage logs of both wells there is also a clear maximum of clay in unit H. Both units in both wells show two maxima of sand. The lower boundary of unit I is sharply defined in the Rudd well, not only by a well-developed glauconitic bed but also by a sharp and pronounced change, shown in both the percentage

log and the synthetic log, from the calcareous material that prevails below it to the more argillaceous material above. In the percentage log of the Seaman well there appears the same sharp increase of shale accompanied by a basal accumulation of sand, but the synthetic log of the Seaman well does not show the sharp lithologic boundary, gray limestones being represented as extending into the lower part of unit I. In the sample from 4,090 to 4,100 feet in the Seaman well, in which the highest gray limestone in unit I appears, traces of very coarse quartz sand with a very few fragments of coarse sandstone like that at 4,072 feet were found, but the scarcity of these fragments and the lack of a definite boundary here in the percentage log make it seem probable that they were derived by caving from beds above. The sample from 4,126 to 4,130 feet in the Seaman well also shows large traces of quartz sand, but no glauconite could be found associated with them. The boundary chosen as the base of unit I is therefore probably the correct one. Probably units H and I together as they appear in the percentage log of the Seaman well record an oscillation, a rise followed by a fall of base-level between units J and G similar to that between units C and B, but the sharp change of facies between units J and I indicates that here the rise of base-level was not continuous from the underlying unit. The upper part of unit I and the lower part of unit H, which were deposited during the period of greatest elevation of base-level, contain several layers with glauconite, sulphide, and sand.

To conform with the boundary between units B and C, the boundary between units H and I in the Seaman well should be taken at 4,045 feet, the approximate position of the akinetic surface, but on account of the greater practical availability of a lithologic boundary and of uncertainty as to the position of the akinetic surface due to the mixed composition of even individual small chips in this part of the section, I have chosen the coarse glauconitic bed shown between 4,068 and 4,072 feet in the synthetic log as the boundary between units H and I. In the sample from 4,060 to 4,070 feet there is about 20 per cent of black calcareous, somewhat glauconitic and very sulphidic sandstone, containing some of the coarsest sand grains noted in any part of the section. But an entirely similar sandstone occurs

in smaller amount between 4,040 and 4,050 feet. The lower sandstone was chosen to mark the boundary between units H and I in this well because it is probably the lowest occurrence of such material, because of its greater abundance, and because it seems to be more closely related to the more definite lower boundary of unit H in the deeper-water deposits of the Rudd well. A light-colored sandstone shown just above 2,765 feet in the Rudd well and indicated by mere traces in the sample may be the equivalent of the one between 4,040 and 4,050 feet in the Seaman well.

A peculiarity of the basal sandstone of unit H in the Seaman well is its shattered condition. Delicate veinlets filled partly with calcite and partly with fibrous chert cut through sand grains, through sulphide concretions, and through cement.

In both wells an increase of lime in the upper part of unit H is shown, reaching its maximum just below the base of unit G.

UNIT J.

Unit J falls in both wells into two parts which are very similar but are separated by a pronounced maximum of clay sharply bounded against the upper part. This maximum is accompanied in the Seaman well by a slight sandiness and especially by a peculiar hard, dense black calcareous material containing a little unusually fresh, rather coarse glauconite and a few phosphate spherules—material of the same type as that which marks the base of the unit. In the Rudd well the clay maximum is accompanied by a relatively large amount of coarse sandstone and sand. As the two parts are in general very similar and as vertical limits of the occurrence of the basal type of materials have not been determined and therefore the boundary can not be definitely placed, the two parts have not been separated as distinct units.

A peculiar feature of the lower division is that it is decidedly more sandy in the Rudd well than in the Seaman well. The difference does not seem to be an error of observation, as samples from the upper part of the lower division in the Seaman well were reexamined and no sand or sandstone fragments were found, though in the Rudd well most of the sand represented in the lower division occurs as sand or sandstone easily recognized in the sample. This relation of the lower part of unit J in the

two wells is directly contrary to that prevailing in all the units previously discussed and is considered further on page 17.

The base of unit J in both wells is marked by probably the best-developed glauconite bed encountered in the section so far discussed—that is to say, the glauconite is unusually abundant, coarse, fresh looking, and thickly scattered through the thin sections. In the material from the Rudd well some of the glauconite partly replaces or fills calcareous skeletons of organisms. There are an unusually large number of phosphate nodules. Sulphide is abundant. Sand is rather abundant in the material from the Seaman well but scarce in that from the Rudd well and not coarse in either. Shells and fragments of shells occur in both wells but are particularly abundant in the Rudd well. In many of the fragments examined these materials lie in a peculiar dense to opaque brown matrix different from any shales in the section. Many chips of this material in the solid look like limestone. A similar substance forms the body of several chips obtained near the middle of unit J, especially in the Rudd well, and is the matrix of the glauconite noted in the sample from 4,230 to 4,240 feet in the Seaman well. Possibly this is phosphatic material. It requires further study.

A peculiarity of the glauconitic bed in the Seaman well is its occurrence in the sample from 4,300 to 4,310 feet but not in that from 4,310 to 4,320 feet, though the character of the material from the lower interval leaves little doubt that it belongs to unit J and not to unit K. As indicated in the introduction (p. 3), many glauconite layers such as are characteristic of unconformities are not directly at the contact, but here the distance separating them is unusually great. In the Rudd well, on the contrary, the glauconite is evidently very near the contact.

UNITS K AND L.

In the percentage logs units K and L respectively appear very similar in both wells, unit K being calcareous and separated rather sharply from unit L. The beds of both units show several lithologic characteristics that distinguish them from overlying beds.

In the Seaman well unit K consists of limestones of a distinct blue-gray color in the solid, as against the black-gray of the overlying lime-

stones. In thin section the limestone is much purer than most beds of the Marble Falls limestone and rather evenly crystalline, with hardly any traces of fossils, but in nearly all fragments of limestones in overlying units at least traces of fossils are recognizable. The shales of units K and L are also very distinctive, and those of unit L are of the same general character in both wells, but the Seaman well shows no shales in unit K. In the solid they have generally a dull brownish-black appearance; in thin section they have a peculiar reddish-brown rusty color and contain an evenly disseminated meal of more or less fine angular sand grains in a vaguely granular argillaceous matrix. A third characteristic type of material looks in the solid hard and compact like limestone but in thin section is seen to consist almost entirely of coarse rhombs of a colorless carbonate in a dense argillaceous matrix. This material was found in unit K in both wells and in the glauconitic bed shown between 3,042 and 3,048 feet in unit L in the Rudd well. Very probably it is dolomitic. I hope later to study it further. Black shales or limestones with more or less of rhombic carbonate in them are not restricted to unit K. They are rather common in unit J, and isolated occurrences were noted in material from 2,400 to 2,410 feet in the Rudd well and in the upper part of unit D in the same well. But in these higher positions the rhombs are usually smaller and not so closely packed.

As may be seen in the synthetic logs, unit K is separated from unit L in both wells by a bed of very phosphatic limestone in which phosphate spherules and nodules and phosphatized calcareous skeletons, including many echinoid fragments, occur rather closely crowded in a crystalline calcareous matrix. This is a typical phosphatic contact bed in which no glauconite was found. Evidently there are different conditions at stratigraphic breaks which make glauconite predominate at some and phosphate at others. In general, the conditions that prevailed during the deposition of units K and L seem to have been more favorable to the formation of phosphate.

Unit L is composed almost entirely of a very uniform succession of shale of the type described above, which in the Rudd well seems to be rather phosphatic, the phosphate occurring as small brown spherules around 0.2 millimeter in diameter, very slightly different in

color in thin section from the shale containing them.

At 3,042 to 3,048 feet in unit L in the Rudd well occurs an exceptionally characteristically developed glauconite and phosphate bed of the contact type. This bed does not, however, appear to separate any distinguishable units. It is probably merely an indication that unit L, like units H and I adjacent to their contact, was formed under conditions approaching those favorable for the formation of accumulations of phosphate and glauconite, so that only a slight shift of base-level was necessary to bring on the favorable conditions. By its associations and in its appearance this bed therefore represents merely a renewal of the conditions that formed the basal bed of this unit. In the Seaman well an equivalent bed may occur in the interval between 4,420 and 4,470 feet not represented by samples.

The well-developed and horizontally extensive glauconite bed that marks the base of the "Bend series," which is here the base of unit L, resting on the Ellenburger (Ordovician) limestone, was mentioned in the introduction. The contact facies is evidently very thin. In the Rudd well only a small amount of coarse sandstone and coarsely glauconitic limestone with some phosphate spherules was found. A peculiarity of the sandstone is that most of the grains were shattered into two to four fragments only slightly displaced and subsequently recemented with what is probably opal. Probably a related phenomenon is the pronounced elongation and straining parallel to the elongation, slight shattering, and penetration of glauconite by sand from the surrounding matrix seen in a fragment of the basal glauconitic shale from 4,490 to 4,510 feet in the Seaman well. Does this indicate movement along this contact plane, perhaps as a result of folding? Shattering, apparently less violent, was noted in the basal sandstone of unit H in the Seaman well. (See above, p. 13.) In the Seaman well the amount of the basal glauconitic material is even less than in the Rudd well, so that is hard to find in the sample. A peculiar feature of the contact zone in the Seaman well is that the bed of shale which carries the coarse glauconite was found only in the sample from 4,490 to 4,510 feet, though the driller places the top of the Ellenburger 9 feet below the base of that interval, and more than half of the sample from

4,510 to 4,519 feet consists of normal shale of the unit L type, apparently free from glauconite with the exception of one fragment, which may well have come from above. The only other trace of glauconite that could be found in that sample was in a minute fragment of crystalline limestone, which was full of it. The basal glauconite bed is not everywhere directly at the contact, but 9 feet is an unusually great distance for the lowest glauconite bed to lie above a contact. Moreover, the sample from 4,490 to 4,510 feet was estimated to contain several per cent of white flint of the Ellenburger type. The relations do not seem entirely normal. In the synthetic log a thin glauconitic limestone deduced from the single fragment found in the sample from 4,510 to 4,519 feet is represented, but this is evidently very hypothetical.

GENERAL CORRELATION WITH THE RECOGNIZED SUBDIVISIONS OF THE "BEND SERIES."

The section in the Rudd well—a sharply defined upper shaly succession from 2,215 to about 2,522 feet (thickness 307 feet), a prevailing limestone succession from 2,522 to 2,962 feet (thickness 440 feet), and below this to the top of the Ellenburger limestone again prevailing shale with a little limestone in the upper part—is so similar to the generally recognized section of the "Bend series" and the Rudd well is so much nearer than the Seaman well to the outcrop where the section was originally observed and named that the Rudd section may be taken as establishing the correlation with the type section. In other words, the upper shale, with the probable exception of the part above 2,245 feet, is the Smithwick; the middle limestone is the Marble Falls limestone; and the lower shale is the "Lower Bend" shale. By means of the correlation proposed in this paper these subdivisions can be carried to the Seaman well.

A few of the facts thus brought out require discussion.

Unit A evidently belongs to the Strawn, but unit B is hard to place. If it lies immediately above the Smithwick it should be the equivalent of what has sometimes been called the "Millsap division." As originally described by Cummins¹⁶ the "Millsap" is composed

mostly of "blue [sandy?] and black [calcareous?] clays, with an occasional sandstone and limestone and an occasional bed of sandy shale. * * * At Thurber * * * the section * * * was principally bluish clay, or, as the miners call it, slate [calcareous shale?], with a few seams of sandstone and limestone." In a subsequent report¹⁷ Cummins dropped the name "Millsap," and still later¹⁸ he explained that by tracing a coal bed of the Strawn formation to Millsap he had convinced himself that the beds there were part of the Strawn. The "Millsap division" of Plummer¹⁹ Cummins says "is not the same thing" as Cummins's "Millsap division." Plummer defines his "Millsap division" as the "beds between the Smithwick shales and the top of the limestone members outcropping in Parker County," though without defining the precise top of the Smithwick. He describes the "Millsap" as consisting, in its best exposure, at Kickapoo Falls, of thick, massive dark-blue shales with lenticular, unevenly bedded limestones. It is very interesting to note that he says that the basal "Millsap" contains a light-colored quartz sand which is in places separated from the Smithwick by blue marls and thin limy layers. That is to say, as appears in my synthetic and percentage logs of the Seaman well, the maximum development of sand is somewhat above the plane of most pronounced lithologic separation. The same agreement with the results presented in the synthetic log in this paper appears in Plummer's statement²⁰ that "in places the black shale [of the Smithwick] grades into a sandy blue and yellow-gray layer above." Regarding the fossils Plummer says that "the three lower limestones [of the "Millsap division"] are found to contain a fauna quite different from the overlying Strawn beds," but also that it is the opinion of Dr. R. C. Moore that the fossils "are much younger than the Bend fauna." The extreme disconformity between units A and B and the seemingly slight disconformity if not transition between units B and C as brought out in Plate I would lead to the belief that unit B, which I

¹⁷ Cummins, W. F., Notes on the geology of northwest Texas: Texas Geol. Survey Ann. Rept., vol. 4, p. 222, 1892.

¹⁸ Cummins, W. F., Am. Assoc. Petr. Geologists Bull., vol. 3, pp. 146-147, 1919.

¹⁹ Plummer, F. B., Preliminary paper on the stratigraphy of the Pennsylvanian formations of north-central Texas: Am. Assoc. Petr. Geologists Bull., vol. 3, p. 140, 1919.

²⁰ Idem, p. 139.

¹⁶ Cummins, W. F., Geology of northwestern Texas: Texas Geol. Survey, vol. 2, pp. 372-374, pl. 6, p. 361, 1890.

take to be about equivalent to Plummer's "Millsap division," should be correlated with the Smithwick rather than with the Strawn.

The presence of a limestone in the lower part of the Smithwick in the Seaman well, instead of the shale in the Rudd well, and of shale below that in the top of the Marble Falls in the Seaman well, instead of the black limestone in the Rudd well, has been discussed above (p. 10) with reference to genesis but requires additional comment with reference to nomenclature. Frank Reeves, who has prepared a report to be published by the United States Geological Survey on part of the Ranger and Eastland oil fields, tells me that in wells in that region a "lime" called the "Smithwick lime" is recognized. It averages about 100 feet in thickness, and its top lies pretty constantly 300 feet above the top of what is there called the "Black lime," taken as the top of the Marble Falls. Between the two lie shales called the "Lower Smithwick shales." In the Seaman well the relation of the limestone between 3,430 and 3,590 feet (thickness 160 feet) in the driller's log or between 3,470 and 3,610 feet (thickness 140 feet) in the synthetic log and the top of a sandy black limestone or calcareous black sandstone at 3,760 feet in both logs (interval in driller's log 170 feet, in synthetic log 150 feet) is so similar to the relation of the "Smithwick lime," allowing for increase in thickness at least of detrital members in the direction in which the Seaman well lies from the Ranger field, that it seems justifiable to assume that the limestone in the lower part of unit C is the "Smithwick lime." Then the "Lower Smithwick shale" is essentially the equivalent of the top of the Marble Falls. Whether paleontology would reveal this relationship is uncertain, as the fauna might be more influenced by environment than by time.

A consideration of thickness ratios in connection with those tabulated on page 17 supports this interpretation. Thus, assuming the Marble Falls in both wells to begin at the top of unit D, we have:

D to J, Rudd 441 feet, Seaman 680 feet, ratio
1: 1.54.

Or, assuming it to begin with the top of unit E in both wells, we have:

E to J, Rudd 344 feet, Seaman 534 feet, ratio
1: 1.55.

Both of these conform to normal ratios. If we assume that unit D in the Seaman well corresponds to the lower part of units C and C' in the Rudd well—that is to say, that it belongs to the Smithwick—we have:

D to J, Rudd, 441 feet; E to J, Seaman, 534 feet; ratio 1: 1.21,

a very low ratio. Or, if we compare Smithwick thicknesses, we have:

C + C', Rudd, 275 feet, Seaman, 595 feet, ratio
1: 2.16,

a high ratio; but assigning unit D in the Seaman well to the Smithwick we have:

C + C', Rudd, 275 feet; C' to D, Seaman, 741 feet; ratio 1: 2.7,

which is the highest ratio between corresponding units in the two wells except that for unit G.

The Marble Falls limestone is so well defined a formation, except for the argillaceous unit D at the top and the limestone of unit K below it, that its identification calls for no special discussion. The well-developed basal bed and the numerous lithologic differences which separate it from unit K have been noted above. The inclusion of unit K with unit L as part of the "Lower Bend," of Mississippian age, as against the Pennsylvanian age of the Marble Falls, is absolutely justified by the fossils. P. V. Roundy, of the United States Geological Survey, who is making very fruitful researches in the neglected field of micropaleontology, reports that in the Seaman well the lowest Pennsylvanian fossils he found were in the sample from 4,300 to 4,310 feet—that is, about 10 feet above the base of unit J—and the highest Mississippian fossils in the sample from 4,370 to 4,380 feet—that is, about 50 feet below the top of unit K. In the Rudd well he found unquestionable Pennsylvanian fossils in the sample from 2,920 to 2,930 feet; probable Pennsylvanian fossils in the sample from 2,945 to 2,950 feet, about 12 feet above the contact; questionable Mississippian fossils in the sample from 2,965 to 2,970 feet, about 3 feet below the contact; and definite Mississippian fossils in the sample from 2,975 to 2,985 feet.

RELATIVE THICKNESS OF THE SECTION IN THE TWO WELLS.

The relative thicknesses of the units are presented in the following table:

The presence of the "Lower Bend" limestone in both wells in proportionately nearly equal thickness underlying the big unconformity that separates it from the Marble Falls

Relative thicknesses of units A to L in Rudd and Seaman wells.

Unit.	Depth of base (feet).		Thickness (feet).		Ratio (Rudd to Seaman).	Name.		
	Rudd.	Seaman.	Rudd.	Seaman.				
A	2,215	2,665				Strawn formation.	Pennsylvanian.	
B	2,247	3,045	32	380	1: 11.87	"Millsap division."		
C	3,610	275	565	1: 2.165(?).....		
C'	2,522+?	3,640						30
D	2,619	3,786	97	146	1: 1.505	Marble Falls limestone (Rudd 44 feet, Seaman 680 feet.)		"Lower Smithwick shale."
E	2,690	3,840	71	54	1: 0.761			
F	2,713	3,870	23	30	1: 1.303			
G	2,744	4,015	31	145	1: 4.68			
H	2,805	4,072	61	57	1: 0.935			
I	2,841	4,132	36	60	1: 1.665			
J	2,963	4,320	122	188	1: 1.541			
K	2,985	4,372	22	52	1: 2.365	Rudd 112 feet, Seaman 199 feet.	"Lower Bend" limestone.	
L	3,075	4,519	90	147	1: 1.635			"Lower Bend" shale.
Total.....			860	1,854	1: 2.155		Mississippian.	
Total without "Millsap division."			828	1,474	1: 1.78			

There is little to generalize about in this table. The region of the Seaman well, as pointed out on page 6, was nearer than the region of the Rudd well to the old land mass from which the "Bend" sediments were derived; hence the section is much thicker there. In some individual units, however, this relation is reversed. Through units C, D, and E there is a continuous decrease in ratios of thickness with increasing deposition of lime, but this relation to lime deposition does not hold throughout the section.

It is worth special notice that the dominant thickness ratio applies also to the "Lower Bend" in the two wells, a fact which indicates that approximately the same land supplied sediment to this region during the earlier Mississippian deposition. This fact opposes the assumption, which is also otherwise improbable, that unit J derived its sediments from a different source than the overlying members of the Marble Falls. The apparently greater sandiness of parts of unit J in the Rudd well than in the Seaman well may therefore, for lack of a better explanation, be tentatively attributed to local currents.

limestone is very surprising. Doubtless the hardness of the "Lower Bend" limestone tended to preserve it as the surface bed, but even so its occurrence in this way, if general, implies a remarkable planation before the deposition of the Marble Falls. Possibly the position of both wells near the axis of the "Bend arch" (see fig. 1, p. 6) has something to do with this similarity. It would be interesting to determine whether any relation exists between position on the "Bend arch" and the erosion of the "Lower Bend" limestone and shale before the deposition of the lowest Pennsylvanian beds.

COMPARISON OF THE SYNTHETIC LOG OF THE SEAMAN WELL WITH THE DRILLER'S LOG.

Mere hasty inspection reveals at once the wide divergences between the synthetic log and the driller's log, the failure of the driller's log to bring out many essential features, and the error in many identifications. In part these errors and inaccuracies are doubtless due to the special difficulties presented by the section in the Seaman well, particularly to the mixing of ingredients in individual beds and the rapid alternation of beds of different composition.

It will not be worth while to go into a detailed comparison; the reader can make his own on the graphic logs, but a few of the larger similarities and differences will be pointed out. In the driller's log of the Seaman well at least part of the true Smithwick shale might be recognized in the blue shale and slate between 3,150 and 3,430 feet, and the approximate limits of the "Smithwick lime" between 3,430 and 3,590 feet. The approximate limits of the "Black lime" are indicated between 3,760 and 3,870 feet. The similarity of the upper part of unit J to the lower part does not appear. My observations indicate that the only basis for the identification of "sand" between 4,190 and 4,200 feet is a small amount of slightly sandy shale, most of the material being pure black limestone. Apparently the driller mistook flint for sand. The "Lower Bend" shale is well defined, and the distinctive blue-gray color of the "Lower Bend" limestone is brought out by the term "dark-gray lime" applied to the material between 4,370 and 4,420 feet, as against "black-gray" applied to the Marble Falls limestone, though the upper boundary assigned is 20 feet too low. The essential fact I wish to emphasize, however, is that no matter how faithfully a log may represent the dominant lithology of any part of the section penetrated it is not likely to bring out those facts which are needed for establishing an accurate correlation. I believe that an adequate basis for arriving at the stratigraphic results needed in present-day oil geology can be furnished only by a graphic percentage log, which, unlike even the best verbal or graphic log of the usual type, records not merely the dominant rock but shows in quantitative terms the proportions within that rock of the principal constituents, and, to supplement this log, the determination of any characteristics or materials of special significance.

GENERALIZED LOG AND POSITION OF OIL SANDS.

To summarize the results of the study of the Rudd and Seaman wells the generalized log in column 6, Plate I, has been prepared. The thicknesses assigned to different parts of the section are based on average thicknesses in the Ranger field, as reported by different writers.²¹

²¹ Reeves, Frank, unpublished report of the United States Geological Survey on the Ranger and Eastland fields and oral communications. Matteson, W. G., Central Texas oil fields: Am. Assoc. Petr. Geologists Bull., vol. 3, pp. 173-175, 1919. Plummer, F. B., Pennsylvanian formations of north-central Texas: Idem, pp. 139-149.

As the Ranger field lies between the two wells the thicknesses used are also for the most part intermediate between those in the two wells. In this log thicknesses of certain beds which I wished to emphasize, especially of glauconite and sandy beds, have been very much exaggerated.

As the most immediate object of this investigation is to supply a framework for determining exactly the stratigraphic position of oil horizons in the "Bend series" in north-central Texas, I have made an attempt to indicate in a general way the possible position in my generalized section of the oil sands recorded by several geologists. The records I have used may be summarized as follows:

Reeves.

[Op. cit. The numbers given to the sands in the generalized log, column 6, Pl. I, in pocket, correspond to the numbers in this list.]

1. "Smithwick lime" (Breckenridge, Caddo, or False Black lime).
2. "Lower Smithwick shale," 80 to 160 feet, above the "Black lime."
3. Top of "Black lime."
4. Second pay, 70 to 130 feet below the top of the "Black lime."
5. McCleskey or Ranger sand, 180 to 220 feet below the top of the "Black lime." Usually directly overlain by gray limestone.
6. Fourth pay, 270 to 300 feet below the top of the "Black lime."
7. Fifth pay, 420 to 460 feet below the top of the "Black lime."

Matteson.

[Op. cit., p. 192.]

- (a) Smithwick shale; oil and gas from lenticular sands.
- (b) Contact of Smithwick and Marble Falls.
- (c) Fincher sand, about 95 feet below the top of the Marble Falls [Marble Falls equals "Black lime"?]. Really a sandy limestone.
- (d) Gordon sand [=McCleskey or Ranger sand?], 130 to 225 feet below top of the Marble Falls. Overlain by 110 to 160 feet of gray lime.
- (e) Jones sand, 325 feet below the top of the Marble Falls (Ranger field).
- (f) Veale sand (Caddo, Stephens County), 640 feet below the top of the Marble Falls.

Hill.

[Hill, R. T., Petroleum in the Texas Bend series; Oil Trade Jour., June, 1918, p. 88.]

- I. At Caddo, Stephens County, immediately below the top of the "Black lime."
- II. South of Breckenridge, Stephens County, at less than 100 feet in the ["Black"] lime.
- III. At Ranger, somewhat over 200 feet in the ["Black"] lime.
- IV. At the Morris ranch in Coleman County, in the midst of black shale, over 200 feet below the bottom of the black lime.

If the top of the "Black lime" is taken at 520 feet in the generalized log, or a little above the top of unit E, and it is remembered that the Seaman well section is thicker and the Rudd well section thinner than that at Ranger, the basis for the identification of oil horizons that I have suggested in the generalized graphic log can be readily worked out. If my attempted identifications are for the most part nearly right a conclusion bearing on the theory of the origin of oil is suggested. Almost all or all the horizons indicated correspond to the highly glauconitic, phosphatic, sulphidic, coarsely sandy beds of the type that marks the bases of units. That the minerals formed at these horizons are all the product of decaying organic matter, probably mostly animal matter resulting from an unusual destruction of life, seems almost certain. Then the presence of oil in these sands may be due not only to the porosity of the sands but also to the accumulation of organic matter directly in association with them.

Deductive considerations in themselves favor this assumption, for the coarsest sands will naturally be deposited at the bases of units, believed to represent the beginning of transgressions, and the coarsest sands are the ones in which oil is generally assumed to accumulate. But as almost all these basal sands are characterized by minerals believed to be due to unusual amounts of organic matter the relation between the coarseness of the sand and the origin of oil directly in it is inherent. Local factors, such as cementation, may determine the exact position of the oil-bearing bed in a sandy succession of beds, but the fact remains that the presence of the oil and that of the sand are independent effects of the same cause, rather than that the presence of the oil is the effect of the presence of the sand. For that reason it makes little difference whether or not in a sandy series like that in and adjacent to unit H, where the Ranger sand probably occurs, the position of the sand corresponds exactly to one of the beds chosen as the base of a unit or not. It is worth noting that the coarsest sandstone from the Seaman well seen under the microscope occurs at the base of unit H, one of the beds suggested as equivalent to the Ranger sand, and that in the same position in the Rudd well a considerable amount

of coarse sand distinguished by a red ferruginous stain was found.

Obviously an attempt to identify oil sands in wells which have not been found to be productive, from general figures and statements as to their positions, is a very speculative and arbitrary proceeding, more likely to express the preconceptions of the author than to form the basis for conclusions. From the synthetic logs of the individual wells it is evident that the wells penetrated numerous thin sandstones that have not been represented in the generalized log and more sand and sandstone than could be represented in the synthetic logs. It has been impossible to indicate in the synthetic logs many sandstones that were neither isolated nor thick, and the driller often fails to record slight amounts of coarse sand or sandstone. On that account the graphic logs can not be taken as conclusive reference data as to the occurrence of possible oil sands. But there are two such sands that can be identified with considerable certainty. One of them is Reeves's No. 3, of which he says that it is at the top of the "Black lime." This is taken to be the same as Matteson's *b*, of which he says that it is at the contact of the Smithwick and Marble Falls (presumably the "Black lime"), and Hill's I, of which he says that it is immediately below the top of the "Black lime." But my logs of the Seaman well show that at the base of unit D calcareous material was deposited, like that at the top of unit E (the major portion of the "Black lime") but more sandy; hence there is good reason for believing that sand No. 3 corresponds with the basal bed of unit D.

The other sand that can be rather definitely identified is the Ranger sand (Reeves's No. 5), of which both Reeves and Matteson say that it is directly overlain by a considerable thickness of gray limestone. The intervals given by Hill, Reeves, and Matteson all agree pretty closely, and as the basal bed of unit G is the only sand found in that part of the section overlain by a considerable thickness of gray limestone, the identification seems fairly trustworthy. The sand at the base of unit H, at 780 feet in the generalized log, is one of the coarsest noticed in the section; and that bed or any of the beds between it and the one at the base of unit G may be the producing bed, but it seems most likely that in the Ranger field the

sand at the base of unit G is the main producing sand. As the Ranger sand, according to Reeves, is in places 40 feet thick it may be that locally the entire sandy portion of the section from the base of unit H to the basal bed of unit G, inclusive, constitutes the productive bed.

NATURE OF THE OIL-PRODUCING BEDS.

The lithologic character of the oil-producing beds seems to be one of the interesting subjects of research in the north-central Texas fields. Though I have no precise evidence as to the stratigraphic position of the oil-bearing beds, I have examined seven samples of reported oil "sands" in the collection of the United States Geological Survey. In a general way these samples consisted of sandy black limestone or shales, in some samples coarsely sandy, in some associated with coarse sandstones, but the latter are usually rather tightly cemented with calcite or silica. In thin section none of these materials appeared porous enough to be good reservoirs for oil. A. F. Melcher, physicist, of the United States Geological Survey, who has made determinations of the porosity of samples of similar material from north-central Texas, has reached the same conclusion,²² and it consequently appears probable to both of us that this material is not the source of the large quantities of oil produced in the region. In view of the fact that in association with one of these samples and with several basal beds in the Seaman and Rudd wells loose grains of coarse sand were found, it seems more probable that there are beds of sand or sandstone so loosely cemented that fragments of them are not recovered in drilling and that these beds yield the oil. This is, however, a question on which those who have studied it more closely and in producing wells are more competent to express an opinion.

TIME REQUIRED FOR THIS METHOD OF WORK.

I found that I could examine the samples at the rate of about two an hour. I had about two thin sections for each sample from the Rudd well and studied these at the rate of about five an hour, but as the materials of the Seaman well were new to me, I studied the thin sections at the rate of about three an

hour. Probably the study of the thin sections from a sample would take nearly as much time as the study of the sample. This is an approximate rate for establishing a type section in a new field. In a small area where the section is established the rate of study might for merely practical purposes be much faster. Thin sections can be prepared at the rate of about one and a half an hour. In addition to the petrographer probably two assistants to grind thin sections and to wash, file, and perhaps make certain tests on the samples would be required. I would urge care in washing the samples, as quartz sand, glauconite, and other important ingredients are frequently among the finer parts and are likely to be washed out.

SUMMARY AND CONCLUSIONS.

In this paper I have attempted to show that the relative proportions of sand, clay, and lime as represented in a graphic log called the percentage log serve to differentiate distinct lithologic elements in a stratigraphic section and to help in their correlation between widely separated wells within a single depositional basin. The boundaries of these units are defined in the percentage log either by sharp changes in the proportions of the constituents or by points marking the maximum of an oscillation of base-level. Where the break between two lithologic elements or units is sharp there usually occurs in the sections here described at or near the base of the upper unit a thin isolated bed containing coarse glauconite, associated with abundant calcareous shells or coarse shell fragments, phosphate, very abundant sulphide, and coarse sand. Any of these constituents may be absent or may predominate. Glauconite is, however, the one most likely to predominate, and after that phosphate.

Where the effect of maximum rise of base-level is marked by the greatest proportion of coarse detrital material in a practically uninterrupted depositional sequence the conditions favorable to the formation of the glauconite bed may not occur just at the same time. In that case the horizon of the surface of the lithosphere at that place at the time of greatest elevation of base-level (the akinetic surface), if it can be definitely recognized, should be taken as the boundary.

²² Oral communication.

Where the percentage composition of the beds above and below the contact of two units is the same, however, it may be necessary to depend on the glauconite bed to mark the boundary.

Directly observable lithologic peculiarities have generally been found useful for separating only the larger, chronologically most widely separated portions of the section, not for differentiating the lesser units.

I wish to emphasize that I do not claim that the methods used here will be applicable everywhere. In regions of deposits formed very near shore, including much sandy material, larger fluctuations may be so confused by local variations of conditions that it may not be possible to disentangle them, though I believe that the method of study by means of the percentage log is always worth trying.

Under these near-shore conditions also glauconite probably does not form, as is indicated by its absence at the base of the Strawn in both wells and at the base of unit B in the nearer-shore Seaman well. On the other hand, as noted above, a typical glauconite layer was found at the base of a sandy formation, probably the Strawn, near Richland Springs, in San Saba County. At least this basal type of formation would be worth looking for in every section until the conditions under which it occurs are better known.

Glauconitic basal beds mark the contact of the Mississippian "Lower Bend" shale with the Ordovician Ellenburger limestone and the contact of the Pennsylvanian Marble Falls limestone with the Mississippian "Lower Bend" limestone. Here they separate units whose distinctness is beyond question. What is then the significance of the units defined by other basal glauconite beds? I think these must be accepted as definite and persistent stratigraphic elements, many of which paleontologic evidence has not yet discriminated. Maybe these elements can not be recognized paleontologically, but that does not invalidate them, if they are persistent and can be recognized lithologically. Probably these units are not all of the same order. The determination of their more exact chronologic and genetic significance in an analysis of sedimentary processes such as that outlined by Barrell²³ must await the accumulation of many more facts. Meanwhile,

it must be realized that faunas and sediments are both complicated responses to complicated conditions and are to the investigator merely tools the accuracy of whose product depends on the skill of the hands that use them. Time and environment are two independent factors in the change of faunas. When the time is relatively short and the changes in environment slight the changes in faunas may be slight, though the lithologic change is widespread and distinct. On the other hand similar lithologic facies may be characterized by faunas that can not be differentiated, though the times at which the similar facies were deposited may be rather widely separated. Therefore, the conclusions that appear to be indicated by fossils can not, I believe, offhand and without critical analysis, be taken to supersede those derived from the rocks themselves.

Lithology has an especial advantage in the correlation of well sections, because lithologic material is obtained from the entire well, but fossils, even micro-fossils, are generally found only at intervals. It is therefore always possible to ascertain a good deal about the lithology and consequently not only to recognize units but, where distinct basal beds are present, as here, to place the boundaries of these units with precision within the limits of a single sample.

Some of the problems awaiting solution by the study of the lithology of well drillings have been referred to in the preceding pages. The most fundamental of these problems is the extension and development of correlation by the work of petrologists and micropaleontologists. The method and conclusions presented here need to be checked, refined, and given greater precision. Other microscopic criteria will doubtless be developed, and chemical and physical tests may be expected to furnish additional criteria. One of the criteria I hope to take up next is the mineralogy of the units. The possibility of finding horizon-marking index minerals, especially among the rarer heavy minerals of sedimentary rocks, has been tested by several investigations. The results have not on the whole been very satisfactory. The great variety of minerals present in any sediment and local variation due to currents or independence of drainage areas feeding into a common basin tend to confuse the differences corresponding to differences in age. However, as index min-

²³ Barrell, Joseph, *Geol. Soc. America Bull.*, vol. 28, pp. 776-834, 1917.

erals, if they can be found, afford a much simpler, more direct, and more rapid means of recognizing horizons than the method here presented they are worth looking for.

Except as a means of locating producing beds, however, correlation is for the petroleum geologist merely a preliminary to the solution of his other problems, such as paleogeography, accumulation and migration of oil, and metamorphism—or, as some may prefer to call it, diagenesis and metamorphism—of the rocks as an index to the processes that have affected the oil. The solution of these problems will be advanced not, I believe, by direct observation in a single well but by compilation of similar data from a great number of wells, in the same way that the problems of surface geology are solved by areal mapping. The acquisition of the necessary data is beyond the capacity of a single individual or a single organization. It is therefore to be hoped that the producers of oil will sufficiently realize the importance to their industry of the solution of these problems to enable their geologists to cooperate in investigating them.

Geologists in general should come to regard the study of well drillings as a field worthy of special attention. The information afforded by a continuous sequence of drillings from a single well, from the wells in an extensive field, and from several fields in a larger area has a detail, completeness, and extension which are generally lacking in surface observations. Moreover, once a field is fully drilled an opportunity to acquire records of its subsurface stratigraphy is gone forever. It is therefore to

be hoped that every effort will be made to preserve complete series of samples from wells and that central places may be found where these samples can be stored for permanent reference.

ACKNOWLEDGMENTS.

Both series of well samples examined for this report were obtained from the Roxana Petroleum Corporation of Texas. The obligation of the United States Geological Survey to this organization for the progressive and enlightened spirit and the readiness to cooperate which made these materials available is so obvious that it need only be mentioned. The writer wishes, in addition, to express his special indebtedness to Mr. E. G. Allen, of that corporation, for his kindness and prompt readiness in helping with information and additional material on many occasions.

The obligation of the Geological Survey to all those organizations and individuals who have furnished samples which for one reason or another happen not to have been used in this investigation is none the less cordially acknowledged.

Personally, I wish to acknowledge my special obligation to Mr. David White, chief geologist of the Geological Survey, whose faith in the possibilities of this investigation led to its initiation and whose encouragement has helped its progress. I am also indebted to Mr. K. C. Heald, assistant chief of the section of the geology of oil and gas fields of the Geological Survey, for procuring samples and in other ways supporting the work.

ORTHAULAX, A TERTIARY GUIDE FOSSIL.

By C. WYTHE COOKE.

INTRODUCTION.

Since the publication of Dall's "Tertiary fauna of Florida" in 1890,¹ when the genus *Orthaulax* was for the first time adequately described, much importance has attached to *Orthaulax* as a horizon marker. Twenty-five years later Dall² voiced current opinion when he said:

This genus is the most characteristic and typical of those belonging to the middle Oligocene of our southern Coastal Plain and the Antilles, including Middle America. It does not appear in the Vicksburgian fauna or the nummulitic Ocala beds of Florida; it seems to have become extinct before the development of the Oak Grove, Fla., fauna. So far it has been recognized in the middle Oligocene of Santo Domingo, Cuba, Antigua, the Canal Zone of Panama, the Tampa silex beds, the Oligocene of Bainbridge, Ga., and the lower bed at Alum Bluff, with its stratigraphically equivalent marl of the Chipola River, Fla. It is not known from the Bowden beds of Jamaica, which are doubtless younger than the Haitian Oligocene explored by Gabb, if indeed the latter be not divisible into several distinct horizons.

But the range in time appears so narrow and the genus so sharply characterized that, according to our present knowledge, the discovery of a species of *Orthaulax* in a Tertiary fauna may be taken as positive proof of its middle Oligocene age.

Since that statement was written the arbitrary boundary between the Miocene and the Oligocene has been shifted downward, so that the range in time of *Orthaulax* as then known straddles the greater part of the Oligocene and the lower Miocene of the present standard geologic time scale. The recent rediscovery of the genotype in an unsuspected stratigraphic position in Santo Domingo, as well as the attempt to identify another species from Santo Domingo, made necessary a critical study of all the available specimens of the genus. The facts assembled in this investigation appear to

me so interesting and important that it seems worth while to restate the old and to put the new on record.

THE GENUS.

Orthaulax is a marine stromboid gastropod resembling the common conch in many respects but curiously different from it in others. While still comparatively young the animal extends the outer lip of its shell to the tip of the spire, and continued growth envelops the entire spire in the domelike body whorl. The narrow space between the spire and the enveloping whorl soon fills with enamel. Some strombs exhibit a similar tendency to cover their spire with enamel and to carry the lip to the summit, but I know of none in which the process begins so young or proceeds so far as in *Orthaulax*. *Hippochrenes* also extends its lip to the spire, but this does not occur until the animal has attained maturity, so that its spire is not wholly involute as in *Orthaulax*. Figure 1, Plate II, representing a living species of *Strombus*, has been introduced for comparison. In all the known species of *Orthaulax* the outer lip lacks the prongs and knobs that characterize many species of *Strombus*, *Rostellaria*, and related genera. The Eocene genus *Calyptrophorus* bears a superficial resemblance to *Orthaulax*, but the covering of the spire of *Calyptrophorus* seems to be simply enamel spread over it after the animal attains maturity and is not an integral part of the shell.

The genus *Orthaulax* was defined in 1872 by Gabb, who used as genotype *Orthaulax inornatus*, from Santo Domingo. In 1887 Heilprin described a new species, *pugnax*, from the "silex bed" of Tampa for which he proposed the new genus *Wagneria*. Three years later Dall described a third species, *O. gabbi*, from the Chipola marl of Florida, and Maury has recently added a fourth species, *O. aguadillensis*, from

¹ Wagner Free Inst. Sci. Trans., vol. 3.

² Dall, W. H., A monograph of the molluscan fauna of the *Orthaulax pugnax* zone of the Oligocene of Tampa, Fla.: U. S. Nat. Mus. Bull. 90, p. 86, 1915.

Porto Rico. *Orthaulax caepta* from Cuba, here described as new,² completes the list of known species of *Orthaulax*.

CRITERIA FOR DISCRIMINATION OF SPECIES.

In discriminating between species of *Orthaulax* several classes of criteria may be used:

The external form of the shell is of value but can not be relied on as infallible. Cross sections of *O. inornatus*, *O. aguadillensis*, and *O. caepta*, so far as we know, are always nearly circular, and *O. pugax* and *O. gabbi* are usually subtriangular, but many immature specimens of *O. gabbi* are circular. *Orthaulax caepta* and *O. aguadillensis* each have two forms, a conical and a hemispherical, which possibly are secondary sexual characteristics. There may be a dome-shaped or hemispherical form of *O. inornatus* also, but it has not been discovered. The conical forms of *O. inornatus*, *O. caepta*, and *O. aguadillensis* may be discriminated from one another by the apical angle, which is most acute in *O. inornatus* and most obtuse in *O. aguadillensis*.

Of considerable value in discriminating between species is the cast of the interior. The casts show the altitude of the whorls and their rotundity or flatness, features which are concealed by the shell, and the outlines of the living chamber, which usually differ considerably from the external form.

Trustworthy identifications of some specimens can not be made without cutting. Axial sections through the apex disclose all the essential features of form and structure. The onion-like arrangement of the layers of shell and callus is laid bare, the outlines, both internal and external, of the whorls at all stages of growth can be traced, and the interrelations of shell substance, enamel, and cavities are plainly visible.

OCCURRENCE AND STRATIGRAPHIC POSITION OF SPECIES.

Orthaulax inornatus.—*Orthaulax inornatus* Gabb, the type of the genus, was first discovered in Santo Domingo. Specimens of this species were collected by Col. T. S. Heneken in 1848 or 1849, but they lay for many years undescribed in the collection of the Geological Society of London. The locality at which they were found is not known. One of Heneken's Dominican specimens was figured by Guppy in 1876,

and the figure is reproduced here (Pl. II, fig. 5). Gabb figured specimens of *Orthaulax inornatus* in 1872 from Santo Domingo, but as he was addicted to the labor-saving but highly reprehensible habit of stuffing his pockets with unlabeled specimens, the locality at which he found them is not recorded.

The stratigraphic position occupied by *Orthaulax inornatus* in Santo Domingo long remained unknown. Because of the presence of this species somewhere in Santo Domingo, presumably in the valley of Rio Yaque del Norte, Maury³ postulated an "*Orthaulax inornatus* formation" regarding which she says:

No one knows where Gabb found his *Orthaulax inornatus* because none of his Dominican fossils were labeled more precisely than "Miocene, Santo Domingo." We presume however, that it was collected from the basal blue clays in the eastern part of the Yaqui Valley, where the revolution prevented our securing sections and collections. For in the western part of the valley we have gone almost to the contact of the Tertiary with the older series, and although a special search was made for *Orthaulax* we did not find it. No doubt the *Orthaulax* zone represents an older horizon than [any] from which we collected.

Regarding the correlation of this hypothetical "*Orthaulax* formation" she says:⁴

The Dominican *Orthaulax* formation is older than those of Bordeaux and represents approximately the Rupelian Oligocene of Europe and the Tampa silex beds and White Beach limestone of Florida. It comes in just above the Vicksburg limestone.

The expedition to the Dominican Republic in 1919 headed by T. W. Vaughan was so fortunate as to procure a typical specimen of *Orthaulax inornatus* associated with so characteristic a fauna and in beds occupying so unmistakable a stratigraphic position as to dispel all doubt as to its age. The *Orthaulax* was collected on Rio Yaque del Norte at Baitoa from the lower part of the Baitoa formation (basal Miocene), which lies unconformably upon the tilted conglomerates and shales of the Tabera formation (middle Oligocene). The corals and mollusks with which the *Orthaulax* is associated have been studied by Vaughan and Woodring, who correlate them with the Burdigalian fauna of Europe and with the fauna of the Chipola marl member of the Alum Bluff formation of Florida.⁵

² Maury, C. J., Bull. Am. Paleontology, vol. 5, pp. 456-457, 1917.

³ Idem, p. 458.

⁴ Vaughan, T. W., and Woodring, W. P., Tertiary and Quaternary stratigraphic paleontology: A geological reconnaissance of the Dominican Republic, p. 96, 1921.

In the United States *Orthaulax inornatus* has never been found in beds as young as the Chipola marl (lower Miocene), but it occurs in the "silex bed" of the next older formation, the Tampa, which is regarded as of upper Oligocene age. The species has also been listed by Dall⁶ from the Chattahoochee formation on Flint River, Ga., but the specimen so named in the collection of the United States National Museum (an impression of a fragment, U. S. Nat. Mus. catalogue No. 166787) appears to be *O. pugnax*.

The two large specimens of *Orthaulax* from Cuba which I figured as *O. inornatus*⁷ proved, on cutting, to be different, and they are here described under the name *Orthaulax caepa*.

Orthaulax gabbi.—The stratigraphic range of *Orthaulax gabbi* Dall appears to be very nearly the same as that of *O. inornatus*, but the two species have not yet been found in the same beds. *Orthaulax gabbi* has not hitherto been reported outside of Florida, where it is abundant in the Chipola marl member of the Alum Bluff formation, but it occurs also in the upper part of the Culebra formation and in the Emperador limestone at several places in the Canal Zone. Some of the Panaman specimens simulate very closely the external form of *Orthaulax pugnax*, and it is only in cross section that their true relationships become evident.

The known range of *Orthaulax gabbi* is upper Oligocene and lower Miocene.

Orthaulax pugnax.—The type of *Orthaulax pugnax* (Heilprin) comes from the "silex bed" of the Tampa formation. The species is common in the lower part of the Chattahoochee formation on Flint River, Ga., and it has been found also in beds of the same age in Alabama and Antigua. My identifications of specimens of *Orthaulax pugnax* from Anguilla⁸ and from Panama,⁹ which were based upon external form alone, are wrong; axial sections show the

first probably to be referable to *O. aguadillensis* and the second to *O. gabbi*.

The stratigraphic range of *O. pugnax* is therefore middle and upper Oligocene.

Orthaulax aguadillensis.—*Orthaulax aguadillensis* Maury is widely distributed in the West Indies but has not yet been reported from the continents. The type was taken by Reeds from the Aguadilla limestone at Aguadilla, P. R. It is probable that some of the specimens of *Orthaulax* collected by Hubbard¹⁰ elsewhere in Porto Rico belong to this species. Large casts of *Orthaulax* that appear to be referable to *O. aguadillensis* have been found on St. Croix (see Pl. III, fig. 4), and one poorly preserved specimen which seems to be *O. aguadillensis* comes from the upper Oligocene Anguilla limestone of Anguilla. In Santo Domingo this species has been collected at widely separated localities; it is fairly abundant but poorly preserved in the Cevicos limestone (upper Oligocene) near the east end of the Cibao Valley, and excellent specimens have been obtained from beds supposed to be of Miocene age at two localities in the valley of Rio Yaque del Sur.

The stratigraphic range of *Orthaulax aguadillensis* appears to be upper Oligocene and Miocene.

Orthaulax caepa.—*Orthaulax caepa* Cooke, n. sp., is known from only one locality, Consolacion del Sur, Pinar del Rio, Cuba. Specimens of this species, which I at first mistook for *Orthaulax inornatus*, proved, when cut, to be more closely related to *O. aguadillensis* but to be different from both. The age of the limestone at Consolacion del Sur is not known, but it is thought to be upper Oligocene.

Correlation table.—In order that the stratigraphic positions occupied by the species of *Orthaulax* may be more readily visualized, the accompanying correlation table has been prepared. The table is not complete but shows only those formations in which *Orthaulax* has been found and enough others to give a stratigraphic background.

⁶ U. S. Nat. Mus. Proc., vol. 51, p. 509, 1916. Plate 88, figure 9, represents a specimen from Ballast Point, Fla., U. S. Nat. Mus. catalogue No. 165099.

⁷ Cooke, C. W., Tertiary mollusks from the Leeward Islands and Cuba Carnegie Inst. Washington Pub. 291, p. 116, pl. 2, figs. 1, 2, 1919.

⁸ Carnegie Inst. Washington Pub. 291, p. 115, pl. 2, fig. 3, 1919.

⁹ U. S. Nat. Mus. Bull. 103, p. 550, 1919.

¹⁰ Hubbard, Bela, Science, new ser., vol. 51, p. 396, 1920.

Known stratigraphic occurrence of Orthotharrax.

Age	Southeastern United States, ^a	Dominican Republic,	Porto Rico and Jamaica,	Leeward Islands,	Cuba,	Panama.
Upper Miocene.	Yorktown and Duplin formations	Cerro de Sal formation.				
	St. Marys formation, ^a	Mao clay.	Bowden marl.		La Cruz marl.	
Middle Miocene.	Choptank formation, ^a	Mao Adentro limestone.				
	Calvert formation, ^a	Guabao formation.				
Lower Miocene.	Shoal River marl member.	Cercado formation.			Marl at Baracoa.	
	Oak Grove marl member.	Baitoa formation.				
Upper Oligocene.	Chapoda marl member <i>O. gabbi</i> .					
	Tampa formation <i>O. paquari</i> , <i>O. thomantus</i> .	Cevicos limestone. <i>O. aquadillaensis</i> .	Aguadilla limestone. <i>O. aquadillaensis</i> .	Anguilla formation and limestone in St. Croix. <i>O. aquadillaensis</i> .	Limestone at Consolacion del Sur (position doubtful). <i>O. carpa</i> , <i>O. gabbi</i> .	Emperador limestone. <i>O. gabbi</i> .
Middle Miocene.	Chert beds on Flint River, Ga. <i>O. paquari</i> .	Tabera formation.		Antigua formation. <i>O. paquari</i> .		Culebra formation.
	Vicksburg group.					

^a Faunal evidence is accumulating, according to T. W. Vaughan, that these formations classed by him in previous reports as Tortonian (upper Miocene), are of Helvetian (middle Miocene) age. This is a return to the opinion stated by Dall in 1904.

SYSTEMATIC PALEONTOLOGY.

Family STROMBIDAE.

Genus ORTHAULAX Gabb.

- Orthaulax* Gabb, Acad. Nat. Sci. Philadelphia Proc., vol. 24, p. 272, 1872. Type *O. inornatus* Gabb, op. cit., pl. 9, figs. 3, 4. Miocene of Santo Domingo.
- Orthaulax* Gabb, Am. Philos. Soc. Trans., new ser., vol. 15, p. 234, 1873.
- Hippochrenes* (part) Zittel, Traité de paléontologie, vol. 2, p. 258, 1887.
- Wagneria* Heilprin, Wagner Free Inst. Sci. Trans., vol. 1, p. 105, 1887. Type *W. pugnax* Heilprin, op. cit., p. 106, pl. 15, figs. 36, 36a. Oligocene of Florida.
- Orthaulax* Dall, Wagner Free Inst. Sci. Trans., vol. 3, p. 169, 1890.
- Orthaulax* Dall, U. S. Nat. Mus. Bull. 90, p. 86, 1915.

The following description of *Orthaulax*, which is quoted from Gabb, 1873, differs from the original description of the preceding year only in a few unimportant verbal changes and alterations in punctuation which do not affect the meaning:

Shell rounded-fusiform, canal moderate, straight and regularly tapering; adult shell enveloped over the whole spire by the extension of the inner lip; posterior canal fissure-like, formed by the continued edge of the outer lip and running directly to the apex. Outer lip apparently sharp and simple; anterior notch oblique and broad.

The discovery of this genus fills an important break in the Rostellarias, uniting the true genus *Rostellaria* with Conrad's *Calyptrophorus*. Unlike both of these genera the canal is not styliform but robust and comparatively short, and its terminal notch is formed by an almost rectangular truncation of the anterior portion of the outer lip. Like *Rostellaria*, it has a straight posterior canal, prolonged, however, further than is common in that genus. The canal is similar in structure to that of *Calyptrophorus*, being formed by a squamose plate; but in the latter genus it curves over backwards, behind the spire, which it ascends to about half its height and then bends down to near the suture of the body whorl. Unlike the first and like the second of its congeners, it has the whole spire enveloped in a plate which should more properly be described as a posterior extension of the body whorl, carrying the suture to the extreme apex. The lines of growth run from the top of the spire to the anterior end of the shell. It carries none of the tubercles seen in *Calyptrophorus* and *Tessarolax* and seems, unlike most of the other genera of the family, to have had a simple outer lip, neither digitate nor notched.

The following excellent description of *Orthaulax* is taken from Dall's Tertiary fauna of Florida:¹¹

This group was described by Gabb from immature specimens, and no perfect specimen has hitherto been figured, for which reason a good deal of doubt has rested upon it.

At first, when I examined young specimens of a genuine *Orthaulax* I was struck by their resemblance to *Leciorhynchus* Gabb, and at once suspected that the latter was only a young specimen of the former. But on examining the type species of *Leciorhynchus* I found that this was not the case, since that shell bore evidences of maturity, has a thickened and lirated lip, is not self-enveloped by the last whorl, and has numerous varices. It is, in short, a form which permanently retains some of the external features of immature *Orthaulax* while adding to them others which are not found in *Orthaulax*.

The genus *Wagneria* of Heilprin is founded on characters which are simply part of the process of mineralization. The type of *Wagneria* is a siliceous pseudomorph; the very thick coating of the spire having been only partially replaced by silica, thus leaving a hollow, geodic dome analogous to nothing in the original shell.

A similar state of affairs is found in many of the fossils of that locality, which present a thickness too great to permit of solid silicification. All the corals, some of the *Turritellas*, etc., offer examples of this kind. For the rest, the relation of his shell to *Orthaulax* was not overlooked by Prof. Heilprin, though he was misled by the state of his material. The name *Wagneria* in any event was preoccupied, and if the genus had proved valid another name would have had to be substituted.

Orthaulax is almost intermediate between *Rostellaria* and *Strombus*. It differs from *Hippochrenes* Montfort, to which it was referred by Guppy and Zittel, in the following characters:

It has not the long, anteriorly produced pillar, nor the widely expanded outer lip; *Hippochrenes* has the last whorl, when adult, posteriorly extended to the tip of the spire, marking the conclusion of its growth; *Orthaulax* while very young has the whorls gradually ascending upon the normal juvenile spire by such an expansion, which, when developed, is continuous, enveloping the whole spire, coiling round and round it as the whorls grow, and completely concealing the whole of the spire, nothing but the outside of the last whorl being visible in an adult specimen.

The following additional remarks on the genus are added by Dall in the same volume, page 172, after his description of the species *O. gabbii*:

The essential difference between *Orthaulax* and *Hippochrenes*, *Calyptrophorus*, *Rimella*, etc., is that the involution of the spire, once commenced, is carried on by the posterior edge of the last or growing whorl continuously from the young condition in *Orthaulax*; while in the others the spire remains normal until the shell reaches its adult state and then, with the changes in the mantle, which incite the deposition of the thickened and enlarged outer lip, a process is developed at the posterior commissure of the aperture and mantle, which deposits enamel on the spire against which it lies, and it thus forms a gutter, sometimes straight, sometimes recurved, in which it is sheltered; apart from this the spire is enveloped, if at all, not by any expansion of the lip, but by a deposit of enamel which covers the whole, as frosting does a cake, without any relation to the coil of the shell considered as an organic product. Strip off the whole enveloping, continuous

¹¹ Wagner Free Inst. Sci. Trans., vol. 3, pp. 169-170, 1890.

enamel from *Calyptrophorus* and the whorls will remain intact; strip off the equivalent deposit in *Orthaulax* and the shell itself is destroyed. The latter, so far as its structure is concerned, is more nearly like an involute *Terebellum* (such as *T. sopitum* Brander, figured by Zittel) than like the enameled *Calyptrophorus* or winged *Hippochrenes*.

The latter wait until they have attained their majority and then spread their outer lips and lay down their enamel, once for all. In *Orthaulax* the involution, as in *Ovulum*, begins before maturity and continues with the growth of the shell without regard to its age or periodical resting stages. In this particular it is clearly distinguished from any other group included in the *Strombidae*, excepting the sufficiently distinct *Terebellum*.

All students appear to agree in referring *Orthaulax* to the family Strombidae. Guppy¹² emphasized its relation to *Rostellaria macrop-tera* (*Hippochrenes*) and Zittel¹³ refers it to *Hippochrenes*. Dall¹⁴ at first considered it a subgenus of *Rostellaria* but in later works¹⁵ returned it to generic rank. In the latter practice he is followed by the second English edition of Zittel's textbook of paleontology (1913) and by recent writers.¹⁶

Orthaulax inornatus Gabb.

Plate II, figures 2-6.

Orthaulax inornatus Gabb. Acad. Nat. Sci. Philadelphia Proc., vol. 24, p. 272, pl. 9, figs. 3, 4, 1872; Am. Philos. Soc. Trans., new ser., vol. 15, p. 231, 1873; Dall, U. S. Nat. Mus. Bull. 90, p. 86, pl. 11, fig. 4, 1915; Dall (part), U. S. Nat. Mus. Proc., vol. 51, p. 509, pl. 88, fig. 9, 1916.

Maury, Bull. Am. Paleontology, vol. 5, p. 285, pl. 47, fig. 11, 1917.

Orthaulax inornata Guppy, Geol. Soc. London Quart. Jour., vol. 32, p. 520, pl. 28, fig. 8, 1876.

In 1873 Gabb described *Orthaulax inornatus* as follows:

Shell broadly rounded-fusiform. Young shell with the spire a little shorter than the aperture, suture impressed, whorls numerous, nuclear whorls three, the subsequent ones showing faint traces of occasional thickenings disposed like the varices of *Triton*; surface smooth; anterior end of body whorl marked by a few faint revolving lines, no posterior canal. Adult shell more distinctly fusiform, the spire covered by a longitudinally striated incrustation covering the sutures and extending to the extreme apex.

¹² Guppy, R. J. L., Geol. Soc. London Quart. Jour., vol. 32, p. 529, 1876.

¹³ Zittel, K. A. von, Handbuch der Palaeontologie, vol. 1, pt. 2, p. 290. Traité de paléontologie, vol. 2, p. 258, 1887. Textbook of paleontology (Eastrin-Zittel), vol. 1, p. 472, 1900.

¹⁴ Wagner Free Inst. Sci. Trans., vol. 3, p. 169, 1890.

¹⁵ U. S. Nat. Mus. Bull. 90, p. 86, 1915; U. S. Nat. Mus. Proc., vol. 51, p. 509, 1916.

¹⁶ Cooke, C. W., Carnegie Inst. Washington Pub. 291, p. 116, 1919; Maury, C. J., Scientific survey of Porto Rico and the Virgin Islands, vol. 3, pt. 1, p. 58, 1920.

Aperture elongated, acute behind and prolonged into a very narrow posterior canal running straight to the apex; in advance it is gradually narrowed, the anterior notch broad and shallow; inner lip thinly incrustated; outer lip thin in all my specimens, and apparently thin, straight, and entire in the perfect adult. Size of largest specimen, length 3.75 inches, width 1.5 inches.

Orthaulax inornatus is the most slender of the known species of the genus. Its apical angle is about 60°, as compared with about 85° in *O. caepa* and about 95° in *O. aquadillensis*. Like those species, it has a circular outline in cross section. In axial sections its most obvious difference from them is in the thinness of the enamel, which in *O. inornatus* is scarcely perceptible but which in both *O. caepa* and *O. aquadillensis* attains a considerable thickness. In spite of the slenderness of the outside of the shell, the living chamber of *Orthaulax inornatus* is more rapidly tapering than that of either *O. caepa* or *O. aquadillensis*, but the whorls themselves are more compressed and flatter. These features, of course, can usually be made out only by cutting the shell or from casts of the interior.

Localities: Upper part of bluff of Rio Yaque del Norte at Baitoa, Province of Santiago, Dominican Republic, station 8668, Condit, collector, 1919; Ballast Point, Tampa Bay, Fla., Post, collector.

Geologic horizon: Baitoa formation, lower Miocene; Tampa formation, upper Oligocene.

Type: Philadelphia Academy of Natural Sciences, from Santo Domingo, Gabb.

Orthaulax pugnax (Heilprin) Dall.

Plate II, figures 7, 8; Plate III, figures 1a-4b.

Wagneria pugnax Heilprin, Wagner Free Inst. Sci. Trans., vol. 1, p. 106, pl. 15, figs. 36, 36a, 1887.

Orthaulax pugnax Dall, Wagner Free Inst. Sci. Trans., vol. 3, p. 170, pl. 8, figs. 5, 8, 1890; U. S. Nat. Mus. Bull. 90, p. 87, pl. 15, figs. 5, 10, 1915; U. S. Nat. Mus. Proc., vol. 51, p. 509, 1916.

Cooke (part), Carnegie Inst. Washington Pub. 291, p. 115, pl. 2, fig. 4, 1919.

Heilprin described *Orthaulax pugnax* as follows:

Shell irregularly oval, obconical, flattened, the flattened appearance being due to three irregular swellings or knobs, one of which immediately adjoins the anteriorly directed fissure of the aperture; aperture narrow, projected forward (in its upper course) as a closely compressed fissure, which in a crescental curve ascends to within a comparatively short distance of the apex of the spire; outer lip? (broken in specimen); inner lip largely developed, completely

concealing the whorls of the spire, and duplicating for a very considerable extent the outer lip; spire freely inclosed in a pointed superstructure, or dome, built over it by an extension of the mantle; surface covered with longitudinal lines of growth, which extend continuously from the apex to the base.

Length (of imperfect specimens, lacking probably upward of an inch), 2.7 inches; width, 1.75 inches.

What the precise relationship of the genus represented by this species may be I am not prepared to say.

Zittel (Handbuch der Palaeontologie, I, part ii, p. 260) unites *Orthaulax* with *Hippochrenes*, but in doing so this eminent paleontologist appears to have been misled by the rather imperfect diagnosis of the fossil given by Gabb. That its position is near to that genus I believe there can be no doubt.

As has been pointed out by Dall (see p. 27), Heilprin mistook a solution cavity in his specimen for a natural feature of the shell. Such a hollow dome would indeed be remarkable.

Orthaulax pugnax is so like *Orthaulax gabbi* that it seems surprising that the resemblances between them were not pointed out long ago. Young shells of both species are almost circular in outline, but older shells are strongly triangular. The outlines of the anterior part of the whorl as shown in figures of the type of *O. pugnax* can be matched perfectly by specimens of *O. gabbi*, but other specimens of *O. pugnax* appear to have proportionately longer and less top-shaped whorls than *O. gabbi*. The most conspicuous difference between the two species consists in the shape of the posterior end of the adult shell, which in *O. gabbi* is nearly always more or less rugose but in *O. pugnax* appears to be usually smooth. However, the range in variation in *O. gabbi* is so great that many specimens are as smooth as *O. pugnax*.

Because of the scarcity of authentic specimens of *O. pugnax* and the unfavorable state of their preservation, no axial sections of specimens from the type area have been cut, and it is not likely that attempts to cut the available material would yield satisfactory results. However, a small specimen from Antigua (Pl. II, figs. 3a, 3b), which seems to be *O. pugnax*, shows that the layers of callus are almost evenly lunate, as in *O. caepa*, but thicker than in *O. caepa* and not knobby, as in most specimens of *O. gabbi*. Another small specimen from the Canal Zone which I had previously identified as *O. pugnax*¹⁷ shows a tendency to knobiness in the callus and also possesses a

much more rapidly tapering living chamber like that in some specimens of *O. gabbi*. I have therefore referred it to *O. gabbi*.

Localities: Ballast Point, Tampa Bay, Fla., U. S. Nat. Mus. catalogue Nos. 112075, Burns, collector, 165100, E. J. Post, collector; Bailey's Mill Creek Sink, three-fourths mile northeast of Lloyds, Jefferson County, Fla., from clay overlying a limestone, L. C. Johnson, collector, U. S. Nat. Mus. catalogue No. 112521; Hales Landing, Flint River, Ga., 7 miles below Bainbridge, Vaughan, collector, 1900, station 3383, U. S. Nat. Mus. catalogue No. 166787 (labeled *O. inornatus*); Hales Landing, Flint River, Ga., Vaughan, Cooke, and Mansfield, collectors, 1914, station 7074, U. S. Nat. Mus. catalogue No. 166788; Blue Springs, Flint River, Ga., Pumphelly, collector, U. S. Nat. Mus. catalogue No. 115747; 1½ miles southwest of Geneva, Ala., Clapp, collector, station 8867; Antigua, Spencer, collector, U. S. Nat. Mus. catalogue No. 166984.

Orthaulax gabbi Dall.

Plate III, figures 5-7; Plate IV, figure 1.

Orthaulax gabbi Dall, Wagner Free Inst. Sci. Trans., vol. 3, p. 170, pl. 12, figs. 5, 5a, 5b, 1890; U. S. Nat. Mus. Bull. 90, p. 87, 1915.

Orthaulax inornatus Dall (part), U. S. Nat. Mus. Proc., p. 509, 1916.

Orthaulax gabbi has been well described by Dall as follows (1890):

Shell large, solid, many-whorled; in the very young smooth and polished, except for incremental lines and a few faintly impressed spiral lines anteriorly; nucleus small, polished, glassy, not differentiated from the rest of the shell; early whorls with a very distinct, not channeled suture; the whorl in front of it slightly turreted; each whorl after the third has three slightly elevated, narrow, rounded varices, somewhat irregularly spaced, so that they do not follow each other continuously down the slope of the spire; about the end of the eighth whorl the posterior edge of the outside whorl begins to be prolonged backward more and more as the shell grows, so that the suture thus formed makes an irregular spiral line ascending the spire over the antecedent whorls until by about the tenth turn the whole of the spire is enveloped, as well as any barnacles, vermetus, or other semiparasitic growth which may have become attached to the surface of the spire; the anterior part of the shell has the shape of *Licorhynchus*; the pillar is rather thick and slightly recurved, with a moderately distinct fasciole; the canal moderately wide, shorter than the pillar; the outer lip simple, sharp, a little thickened at the resting stages, but not liriate internally; body with a moderate callus, which at the resting stages is considerably enlarged, so that when the whorl comes to grow over it (as it is not absorbed) it produces an irregularity

¹⁷ U. S. Nat. Mus. Bull. 103, pp. 550, 553, 1919.

somewhat like a varix; the whorls are ovately rounded, smooth, except for occasional transverse undulations due to irregularities of growth, and polished; no indications of color pattern have been observed.

The adolescent form a good deal resembles a *Strombus* except that the anterior sulcus of the outer lip behind the canal is absent or represented only by the faintest wave in the margin; the spire is entirely enveloped by the backward prolongation of the last whorl, except at the tip, where the envelope is usually a little eroded or defective; there appears to be a resting stage at every two-thirds of a revolution of the whorl around the axis, for which reason, looking down on the spire, the outline of the shell transverse to the axis is subtriangular or three-sided; the outer lip is simple, rather sharp-edged, and very slightly, if at all, recurved; it extends backward to the tip of the spire, near which it recedes somewhat from its parallelism with the axis; at the shoulder, also, it is slightly excavated and thickened; the body is smooth, with a moderate callus, which becomes thicker near the shoulder; at the shoulder, in front of the excavation above noted, it becomes very thick and is continued on to the spire parallel with the outer lip, and very near it, so that between the two is a narrow, flexuous groove of considerable depth; when the shell begins to grow again the whorl is carried over this ridge, which is not absorbed, and the surface is thus rendered, as it were, varicose; the canal is short, strongly recurved, with a remarkably deep siphonal sulcus, so that the end of the pillar stands forward in a marked way; on the shoulder, halfway around the shell, is an ill-defined narrow ridge, which ceases a little way behind the lip. The dimensions of the figured specimen are: Longitude, 68 millimeters; maximum latitude, 35 millimeters.

The adult form differs from the adolescent by the disproportionate strength of the ridge at the shoulder, by which the surface behind the ridge has become flattish, as in a *Cassis*, but more irregular, and the width at the shoulder has increased in proportion to the total length. No entirely complete specimen of the adult has been found, but from numerous fragments the proportions can be approximately determined. The maximum diameter is 74 millimeters, and the length about 11 millimeters, of which 15 millimeters are behind the shoulder, while, in the specimen only 68 millimeters long, there are 17 millimeters of length behind the shoulder.

This species appears abundantly, though in a poor state of preservation, in the lower bed at Alum Bluff and in the Chipola beds to the westward. The group in America would seem to be characteristic of the lower beds of the southern Miocene, as far as our present knowledge permits us to judge.

I have observed that, occasionally, the ridge on the shoulder in young specimens is represented by a nodule rather than a ridge.

The resemblance of *O. gabbi* to *O. pugnax* is noticed under the description of *Orthaulax pugnax*.

Localities: Tenmile Creek, 1 mile west of Bailey's Ferry, Chipola River, Fla., Burns, collector, station 2212; 1 mile below Bailey's

Ferry, banks of river above white limestone bed, Burns, collector, 1889, station 2213; right bank of Chipola River on McClelland farm, 1 mile below bridge at old Bailey Ferry, Calhoun County, Fla., Dall, collector, 1893, station 2564; same locality, Vaughan, collector, 1900, station 3419; lower bed at Alum Bluff, Apalachicola River, Fla., Burns, collector, 1889, station 2211; same locality, Cooke and Mansfield, collectors, 1914, station 7183; Panama Railroad, 2 miles south of Monte Lirio, formerly known as Mitchellville, Canal Zone, MacDonald, collector, 1911, station 5901; upper part of Culebra beds on west side of Paraiso, MacDonald, collector, 1913, station 6515; topmost limestone in Gaillard Cut opposite Las Cascadas, Canal Zone, MacDonald and Vaughan, collectors, 1911, station 6019-g (two casts of the interior, identification very doubtful).

Type: U. S. Nat. Mus. 112218.

Orthaulax aguadillensis Maury.

Plate IV, figures 2-6; Plate V, figures 1a, 1b.

Orthaulax aguadillensis Maury, Scientific survey of Porto Rico and the Virgin Islands, vol. 3, pt. 1, p. 58, pl. 9, fig. 4, New York Acad. Sci., 1920.

Orthaulax pugnax Cooke, C. W. (part), Carnegie Inst. Washington Pub. 291, p. 115, pl. 2, fig. 3, 1919.

Maury's description is as follows:

Shell large and heavy; form of spire short and blunt, like that of *Orthaulax pugnax*. This at once distinguishes the shell from the Dominican species *O. inornatus* Gabb, which is high-spined. A further characteristic of the shell is the evenly rounded form of the shoulder, which in cross section would be almost perfectly circular. This marks it off very decisively from the Floridian Chipolan species *Orthaulax gabbi* Dall, which is markedly triangular at the shoulder. The spire measures 45 millimeters in diameter.

A single specimen of this *Orthaulax* was collected by Reeds at Aguadilla. It is imperfect but undoubtedly a typical member of this very important index genus.

The shell was submitted to Dall, who compared it with the types of the various known species in the National Museum. He replied that "The *Orthaulax* is nearest to *O. pugnax*, but as the margin of the spire is gone it is impossible to be certain. I think it is new."

One might be criticized for describing so incomplete a specimen as new were this a less rare and less stratigraphically important genus. Moreover, no complete adult shell of either *O. inornatus* or *O. pugnax* has ever been found. Though heavy and apparently strong, the shells seem to go to pieces very easily, and usually one finds only heads, as in this case, or fragments of the heavy pillars.

No other molluscan shells were found associated with this *Orthaulax*, but an echinoderm occurred.

It is a little surprising that the nearest ally of this Puerto Rican *Orthaulax* should be not Gabb's *O. inornatus*, from the adjacent island of Santo Domingo and in the Tampa and White Beach beds, Florida, but *O. pugnax*. The latter ranges geographically from the Tampa, Fla., beds and those of Bainbridge, on the Flint River, Ga., to Cuba, Antigua, and the Canal Zone, and geologically from the middle Oligocene of Antigua to the upper Oligocene of the Tampa and Flint River formations.

Orthaulax aguadillensis resembles *O. caepa* in size and appearance but differs from it in several respects: *O. aguadillensis* is blunter, the apical angle being a little greater than 90° , whereas that of *O. caepa* is a little less than 90° ; some specimens of *O. aguadillensis* show faint grooves on the anterior part of the shell but no raised threads such as are found on *O. caepa*; most of the callus on *O. aguadillensis* is deposited just in front of the shoulder and is proportionately somewhat thicker than in *O. caepa*, on which the callus is more evenly distributed and is lunate in cross section.

Localities: Aguadilla, P. R., station 3, Reeds, collector; road from Cotui to Cevicos on east side of Arroyo Blanco east of Loma de los Palos, Dominican Republic, station 8598, Cooke and Ross, collectors, 1919; left bank of Rio Yaque del Sur at upper edge of Los Guiros, Province of Azua, Dominican Republic, station 8572, Condit, collector, 1919; west bank of Rio Yaque del Sur opposite Palo Copado, Province of Azua, Dominican Republic, station 8590, Condit, collector, 1919; Crocus Bay, Anguilla, station 6965, Vaughan, collector (identification doubtful).

Geologic horizon: Aguadilla limestone, Cevicos limestone, and Anguilla formation (?), upper Oligocene; Yaque group (?), Miocene.

Type: American Museum of Natural History.

Orthaulax caepa Cooke, n. sp.

Plate V, figures 2a-3b.

Orthaulax inornatus Cooke, Carnegie Inst. Washington Pub. 291, p. 116, pl. 2, figs. 1, 2, 1919.

Shell large, heavy, circular in cross section; first six whorls, more or less, bare in juvenile shell but completely enveloped by subsequent whorls; callus-filled spaces between whorls evenly lunate in axial sections through the apex; apex conical, with apical angle of about 85° , or hemispherical; whorl in front of the shoulder ornamented with fine raised revolving threads.

Orthaulax caepa is intermediate in shape between *O. inornatus* and *O. aguadillensis*. Its apex is blunter than that of *O. inornatus* but more acute than that of *O. aguadillensis*. It differs from both in the ornamentation of spiral threads in front of the shoulder. The cast of the interior appears to be more slender than that of either *O. inornatus* or *O. aguadillensis*, and the whorls of the cast to be more rounded than those of *O. inornatus* but very similar to those of *O. aguadillensis*. The callus in *O. caepa* is evenly lunate, but that of *O. aguadillensis* is asymmetric, the greatest thickness being in front of the shoulder, and is much thicker in proportion to its length than that of *O. caepa*; the callus is thin and inconspicuous in *O. inornatus*.

There are two forms of *O. caepa*, a pointed or conical form and a domed or hemispherical form. It is possible that these different shapes may be secondary sexual characteristics.

Locality: Consolacion del Sur, Pinar del Rio, Cuba, station 3474.

Geologic horizon: Oligocene (?).

Type: U. S. Nat. Mus. catalogue No. 166980.

PLATES II-V.

PLATE II.

	Page.
FIGURE 1. <i>Strombus costatus</i> Gmelin. Living in the Caribbean Sea.....	23
2. <i>Orthaulax inornatus</i> Gabb. Young shell from Santo Domingo. After Gabb, 1872, pl. 9, fig. 4.....	28
3. <i>Orthaulax inornatus</i> Gabb. Type, from Santo Domingo. After Gabb, 1872, pl. 9, fig. 3.	
4. <i>Orthaulax inornatus</i> Gabb. Ballast Point, Fla. After Dall, 1915, pl. 11, fig. 4. U. S. Nat. Mus. catalogue No. 165099.	
5. <i>Orthaulax inornatus</i> Gabb. Santo Domingo. After Guppy, 1876, pl. 28, fig. 8.	
6. <i>Orthaulax inornatus</i> Gabb, $\times 2$. Baitoa, Dominican Republic. U. S. Nat. Mus. catalogue No. 328256.	
7, 8. <i>Orthaulax pugnax</i> (Heilprin) Dall? Cast of interior, $1\frac{1}{2}$ miles southwest of Geneva, Ala. U. S. Nat. Mus. catalogue No. 328255.....	28



3

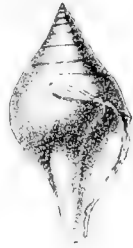

2



4

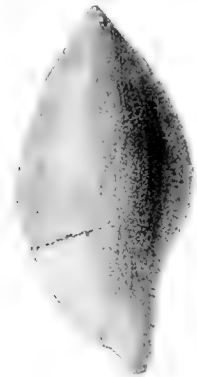

5



1

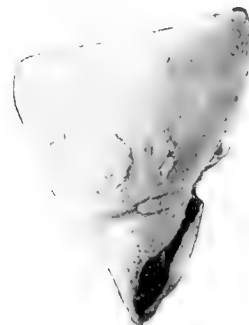

7



8



6

X2

STROMBUS AND ORTHAULAX.



1a



3a

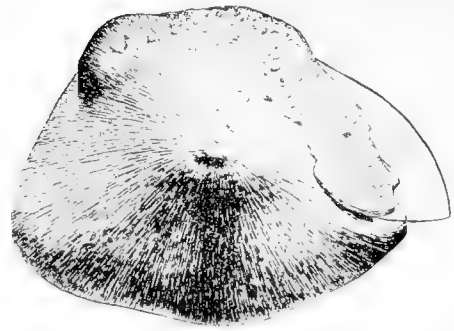

1b

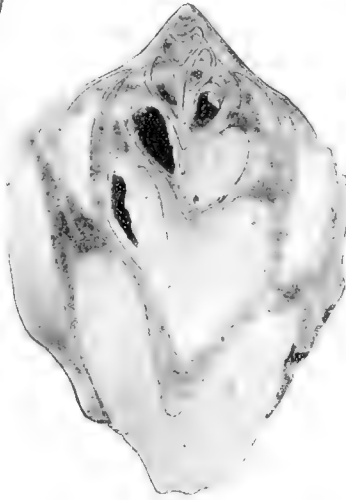

3b

x2



2

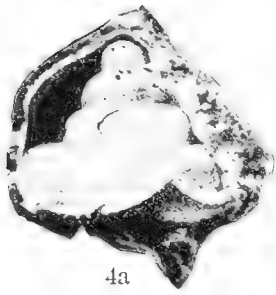

4a



4b



5



6a



6b



7

ORTHAULAX

PLATE III.

	Page.
FIGURE 1a. <i>Orthaulax pugnax</i> (Heilprin) Dall. "Silex beds" of Tampa formation. After Dall, 1915, pl. 15, fig. 5. U. S. Nat. Mus. Catalogue No. 165100.....	28
1b. <i>Orthaulax pugnax</i> (Heilprin) Dall. "Silex beds" of Tampa formation. After Dall, 1915, pl. 15, fig. 10. Same individual as shown in figure 1a.	
2. <i>Orthaulax pugnax</i> (Heilprin) Dall. Blue Springs, Ga. U. S. Nat. Mus. catalogue No. 115747.	
3a. <i>Orthaulax pugnax</i> (Heilprin) Dall. Antigua. After Cooke, 1919, pl. 2, fig. 4. U. S. Nat. Mus. catalogue No. 166984.	
3b. <i>Orthaulax pugnax</i> (Heilprin) Dall. Axial section, $\times 2$, of individual shown in figure 3a. The discontinuity in the anterior part of the columella is not due to resorption of the walls, but to the section having been cut at a small angle to the plane of the axis.	
4a. <i>Orthaulax pugnax</i> (Heilprin) Dall. Type, from "silex beds" of Tampa formation. After Heilprin, 1887, pl. 15, fig. 36.	
4b. <i>Orthaulax pugnax</i> (Heilprin) Dall. Type. After Heilprin, 1887, pl. 15, fig. 36a.	
5. <i>Orthaulax gabbi</i> Dall. Young individual from Chipola marl of Florida. After Dall, 1890, pl. 12, fig. 5. U. S. Nat. Mus. catalogue No. 112218.....	29
6a, b. <i>Orthaulax gabbi</i> Dall. Type, $\times 0.85$, from Chipola marl of Florida. After Dall, 1890, pl. 12, figs. 5a, 5b. U. S. Nat. Mus. catalogue No. 112218.	
7. <i>Orthaulax gabbi</i> Dall. Pailey's Ferry, Fla., station 3419.	

PLATE IV.

	Page
FIGURE 1. <i>Orthaulax gabbi</i> Dall. Alum Bluff, Fla., station 2211. U. S. Nat. Mus. catalogue No. 328254.....	29
2. <i>Orthaulax aquadillensis</i> Maury. Type. Aguadilla, Porto Rico. After Maury, 1920, pl. 9, fig. 4....	30
3. <i>Orthaulax aquadillensis</i> Maury? Anguilla. After Cooke, 1919, pl. 2, fig. 3. U. S. Nat. Mus. catalogue No. 166982.	
4. <i>Orthaulax aquadillensis</i> Maury. Hemispherical form. St. Croix. U. S. Nat. Mus. catalogue No. 328261.	
5. <i>Orthaulax aquadillensis</i> Maury. Conical form, $\times 2$. Los Guiros, Dominican Republic. U. S. Nat. Mus. catalogue No. 328258.	
6. <i>Orthaulax aquadillensis</i> Maury. Palo Copado, Dominican Republic. U. S. Nat. Mus. catalogue No. 328260.	



1



4

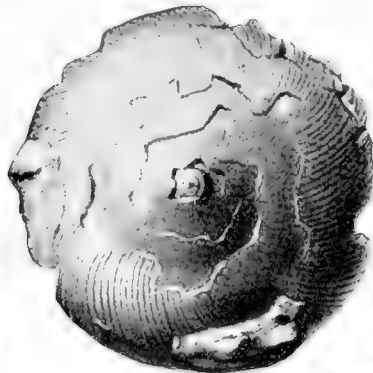

2



3



5

X2



6

ORTHAULAX.



1b x2



3a

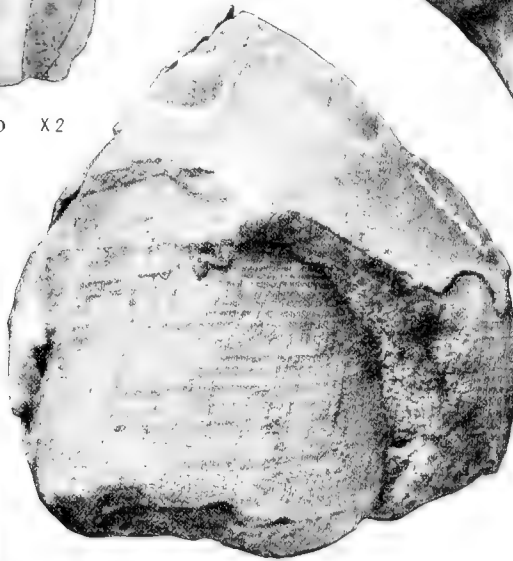

2a



1a



3b

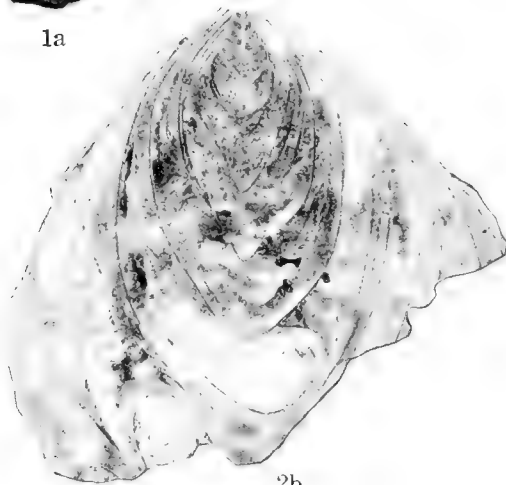

2b

ORTHAULAX.

PLATE V.

	Page.
FIGURE 1a. <i>Orthaulax aquadillensis</i> Maury. Hemispherical form. Los Guiros, Dominican Republic, station 8572. U. S. Nat. Mus. catalogue No. 328257	30
1b. <i>Orthaulax aquadillensis</i> Maury. Axial section of specimen shown in figure 1a, - 2.	
2a. <i>Orthaulax caepa</i> Cooke. Type. Consolacion del Sur, Cuba. After Cooke, 1919, pl. 2, fig. 2. U. S. Nat. Mus. catalogue No. 166980	31
2b. <i>Orthaulax caepa</i> Cooke. Axial section of specimen shown in figure 2a.	
3a. <i>Orthaulax caepa</i> Cooke. Hemispherical form. Consolacion del Sur, Cuba. After Cooke, 1919, pl. 2, fig. 1. U. S. Nat. Mus. catalogue No. 166980.	
3b. <i>Orthaulax caepa</i> Cooke. Axial section of specimen shown in figure 3a.	

GRAPHIC AND MECHANICAL COMPUTATION OF THICKNESS OF STRATA AND DISTANCE TO A STRATUM.

By J. B. MERTIE, Jr.

INTRODUCTION.

Two problems that constantly confront the stratigraphic and structural geologist are the computation of the thickness of a geologic section and the computation of distance to a stratum from some designated point at the surface when the position of the outcrop of that stratum is known. The solution of each of these problems is divisible into three parts—a geometric solution, a trigonometric generalization, and simplified methods of computation. It is the purpose of the present paper to consider these three phases of each of the two problems above mentioned.

Analyses of these two problems, so essentially a part of the geologist's work, have doubtless been previously made, but it is odd that so little has been published on this subject, and particularly significant that most of the published material has been of recent origin. The obvious inference is that we are approaching a period in the development of geologic science when accurate data will be considered more and more essential to correct stratigraphic interpretation; and the recent interest shown in these and related problems is an index of the general appreciation of this fact by geologists. In other words, geology is changing progressively from a qualitative to a quantitative science, and older methods are giving way to newer ones more adapted to present needs.

The only fault that may be found with the material so far published on this subject lies in its incompleteness. In some of the published papers the writers have not worked out general formulas but have confined themselves to the consideration of special cases, the solution of which, though useful, is not of universal application. In other articles, in which universal solutions have been evolved, the treatment is not well balanced because the above-mentioned three phases of each of the two main

problems have not been considered adequately. Thus, a geometric solution is of interest, but if that alone comes within the scope of the article its value will be impaired because no formula is deduced, and the geologist will have to repeat the solution for every individual set of data. The trigonometric solution is of much more value, but it will not be used by many workers because it requires mathematical computation. It is very desirable that graphic or mechanical methods be employed in the solution of all geologic formulas, first because in using such methods no knowledge of trigonometry is required, second because of the saving in time they permit, and third because the resulting solutions are well within the limits of accuracy imposed by the nature of geologic observations.

The principal publications known to the writer in which the problems of thickness of strata and depth to a stratum are considered are as follows:

Hayes, C. W., Handbook of field geology, 1909.

Roe, J. W., Application of descriptive geometry to mining problems: Am. Inst. Min. Eng. Trans., vol. 41, pp. 512-533, 1911.

Smith, W. S. T., Some graphic methods for the solution of geologic problems: Econ. Geology, vol. 9, No. 1, 1914.

Palmer, H. S., Nomographic solutions of certain stratigraphic measurements: Econ. Geology, vol. 11, No. 1, 1916.

Palmer, H. S., New graphic method for determining the depth and thickness of strata and projection of dip: U. S. Geol. Survey Prof. Paper 120, pp. 123-128, 1919.

In Hayes's Handbook trigonometric formulas are derived, but only that special case is considered where the field traverse is made perpendicular to the strike of the beds. Both Roe and Smith have made descriptive geometric solutions, but neither derives formulas therefrom. In his first article Palmer has derived the general formula for the calculation of thickness of strata and developed three-variable alinement charts for its graphic solution. In his second article he has developed three-vari-

plane of reference, may be measured, thus determining the distance OL. The line LK drawn parallel to S_1T is the trace of the top of the stratum upon the reference plane. Draw a line connecting and perpendicular to LK and S_1T . Such a line, EH, is the distance between the traces of the outcrops of the base and top of the stratum, upon the horizontal plane. When δ and EH are known the right triangle HDE may be revolved 90° upward on EH as an axis into the plane of reference and the thickness of the stratum (DE or t) may be measured.

TRIGONOMETRIC FORMULA.

The trigonometric solution from this construction is as follows:

$$t = (HR + RE) \sin \delta$$

$$HR = h \sin \alpha \quad \text{and} \quad h = s \cos \sigma$$

$$\therefore HR = s \sin \alpha \cos \sigma$$

$$RE = \frac{e}{\tan \delta} \quad \text{and} \quad e = s \sin \sigma$$

$$\therefore RE = \frac{s \sin \sigma}{\tan \delta}$$

Hence

$$t = \left(s \sin \alpha \cos \sigma + \frac{s \sin \sigma}{\tan \delta} \right) \sin \delta$$

$$t = s (\sin \alpha \sin \delta \cos \sigma + \cos \delta \sin \sigma)$$

When the dip of the beds and the slope of the hillside are in the same direction, the + in the formula changes to -. The general formula therefore is

$$t = s (\sin \alpha \sin \delta \cos \sigma \pm \cos \delta \sin \sigma) \dots (1)$$

GRAPHIC REPRESENTATION OF THE FORMULA.

GENERAL PRINCIPLE.

Computations may be performed numerically, graphically, mechanically, or by a combination of methods. Numerical solutions of formulas require the use of logarithmic tables and are avoided when possible chiefly because they require too much time. It is highly desirable to represent formulas graphically or to compute them by some mechanical device based on a graphic representation of the functions involved. If some one formula is used a great deal, it should preferably be represented graphically, thus saving much time in computation and reducing greatly the liability of errors in the result. If a variety of formulas are being used, it will perhaps be found more convenient to perform the com-

putations by means of some universal computing machine, such as a slide rule.

The formula for the thickness of a stratum, as above given, is one that may be used repeatedly in certain kinds of stratigraphic work or only occasionally in other kinds but certainly is of use to every stratigraphic geologist. There are several objections to the numerical computation of this formula. First, too much time is required; second, the use of figures introduces a greater liability to error than a graphic computation; and third, the accuracy of the answer, if five-place logarithmic tables are used, is much greater than the character of the original data justifies. The matter of needless accuracy is often overlooked by geologists, with the result that meaningless figures and incongruous results are sometimes published. In general it is true that in formulas used by geologists in the field and office some one of the variables will depend on an observation of the strike or dip of rocks. The answer to the formula should obviously be no more accurate than the least accurate of the component variables. For example, it is very doubtful whether determinations of strike or dip can be made with an error of less than 1° . But even if 1° represents the maximum probable error in careful work, it must be remembered that geologic strata do not by any means have mathematically perfect surfaces. Therefore an additional possibility of error is introduced in the liability of the measured direction of strike or dip of surface to change within a comparatively short distance, thus vitiating a most carefully made measurement. Extreme accuracy in computation of geologic formulas is therefore neither needful nor desirable, and graphic methods should be used.

The graphic representation of a formula is commonly accomplished by means of Cartesian coordinates, but this system has serious drawbacks when equations of more than two variables are to be plotted. When equations of three variables must be represented, a system of curves must be drawn and an awkward interpellation used. For equations of more than three variables Cartesian coordinates are not suitable. The equation

$$t = s (\sin \alpha \sin \delta \cos \sigma \pm \cos \delta \sin \sigma)$$

comprises five variables, namely, t , s , α , δ , and σ . Equations of three variables are most easily

represented by means of a nomograph or alinement chart, which in reality is a system of plotting by means of parallel coordinates. Three excellent treatments of this method of graphic analysis have been written, by D'Ocagne,¹ Lipka,² and Peddle,³ and the reader is referred to their publications for an understanding of the theory of the alinement chart.

In plotting the above formula Palmer⁴ used their three-variable nomograms, thus necessarily solving the formula by several independent operations. Thus $\sin \delta$ and $\cos \sigma$ were multiplied in one operation, and the product multiplied by $\sin \alpha$ in a second operation. $\cos \delta$ and $\sin \sigma$ were multiplied in a third operation. The products of the second and third operations were then added numerically by a fourth operation, and this sum multiplied by s in a fifth operation, to solve for t . Three charts were required for these operations, one to multiply sines by cosines, a second to multiply numbers by sines, and a third to multiply numbers by numbers. Moreover, as the nomographic solution with parallel scales, which is the one employed, is essentially a method of addition and subtraction, and as all the above-mentioned operations that were performed graphically involve multiplication, all the calibrated scales were necessarily logarithmic scales. A serious drawback exists in the use of logarithmic scales, because the accuracy of the reading is greater at one end of the scale than at the other, and this weakness is specially pronounced in logarithmic scales of the trigonometric functions. By the method here used, the solution of the equation

$$t = s (\sin \alpha \sin \delta \cos \sigma \pm \cos \delta \sin \sigma)$$

is effected by a compound operation, in which a single chart and natural instead of logarithmic functions are employed.

The above equation, containing five variables, can not be plotted directly by any method in two dimensions known to the writer, but by separating it into two parts and equating each of these to some auxiliary variable, the equation may be readily charted. Thus the

equation may be written in two parts as follows:

$$t' = \frac{t}{s} \text{-----} \quad (2)$$

$$t' = \sin \alpha \sin \delta \cos \sigma \pm \cos \delta \sin \sigma \text{---} \quad (3)$$

where t' is the introduced auxiliary variable. Equation (2) is a problem in division or, when written $t = t' s$, a problem in multiplication and therefore can not be plotted with natural scales if an alinement chart with parallel scales is used. By employing a nomographic Z chart, however, natural scales may be employed in multiplication and division, and this is the method which has been used.

Equation (3), however, is well adapted to graphic representation by an alinement chart with parallel scales, as the primary operation to be performed is addition or subtraction, as indicated by the symbol \pm . This equation, however, presents a difficulty in that it expresses a relationship between four variables—that is, t' , α , δ , and σ . If one of these variables could be regarded as a constant, the equation would be reduced to a three-variable type. The obvious solution consists in assigning to one variable a series of fixed values and computing the resulting curves for each particular value. Two variables will be plotted on two parallel scales, and a third variable, whose position is partly determined by the fixed value assigned to the fourth variable, will be plotted between the two parallel scales. For each fixed value assigned to the fourth variable a different curve of the third variable will be developed, and the composite result will be a series of curves expressing the third variable in terms of the fourth. These curves may be joined together by a set of auxiliary curves, drawn through points of equal value of the third variable, and a gridwork of intersecting curves will be formed which will express graphically the true relationship between the third and fourth variables.

In the practical application of this method the variable t' is assigned to one of the outer parallel scales, in the plotting of both equations (2) and (3). The same scale modulus is used, and as both solutions involve only natural functions, the scale of t' for each solution is the same, and a common support for the scale t' may be used. Three parallel supports are therefore used to plot the variables α , t' , and t .

¹ D'Ocagne, Maurice, *Traité de nomographie*, Paris, Gauthier-Villars, 1869.

² Lipka, Joseph, *Graphical and mechanical computation*, New York, 1918.

³ Peddle, J. B., *The construction of graphical charts*, 2d ed., New York, 1919.

⁴ Palmer, H. S., *Nomographic solutions of certain stratigraphic measurements*: Econ. Geology, vol. 11, 1916.

The variables δ and σ are expressed in a gridwork of curves lying between α and t , and the variable s is plotted upon a diagonal line connecting opposite ends of the t' and t scales. As no numerical value of t' is required, the support of the t' scale is not calibrated. Thus in the operation of the chart a point upon the α scale representing some value of α is connected by a straight line with a point which represents given values of δ and σ in the gridwork of curves and produced to meet the uncalibrated scale t' . The intersected point is then connected by another straight line with a point on the diagonal line representing some value of s and projected to the t scale, the reading on which shows directly the thickness of the stratum, vein, or formation.

MATHEMATICAL ANALYSIS.

EQUATION (2).

The equation $t = t's$ may be written as

$$f_1(u) = f_2(v) \cdot f_3(w)$$

where $t = u$, $t' = v$, and $s = w$. In figure 3, let t' and t be plotted upon two parallel straight-line scales, oppositely directed. The diagonal line joining the zero ends of these two scales will be the locus of the scale z and will be considered to have a length of k . Draw any nomographic index line joining the t' and t scales and intersecting the z scale. In the diagram,

$$y : x :: k - z : z$$

$$x = \frac{z}{k-z} y$$

The above equation is evidently in the form $f_1(u) = f_2(v) \cdot f_3(w)$. Therefore, assigning scale moduli of m_1 and m_2 respectively to $f_1(u)$ and $f_2(v)$, we may say that

$$x = m_1 f_1(u) \text{ and } y = m_2 f_2(v)$$

As t' and therefore t and s must be plotted as natural functions, in order to be coordinate with the chart of equation (3), the Z type of alinement chart is used. The method of analysis is that used by Lipka.⁵ Hence the equation becomes

$$m_1 f_1(u) = \frac{z}{k-z} \cdot m_2 f_2(v)$$

or

$$f_1(u) = \frac{m_2 z}{m_1(k-z)} \cdot f_2(v)$$

Therefore

$$\frac{m_2 z}{m_1(k-z)} = f_3(w)$$

and from the solution of this equation it is found that

$$z = k \frac{m_1 f_3(w)}{m_1 f_3(w) + m_2} \quad (4)$$

From equation (4), by substituting the specified moduli and values of $f_3(w)$, a series of values of z can be computed, which will represent the calibration of the diagonal scale, or scale of s .

EQUATION (3).

Consider the positive form of equation (3) that is to be plotted:

$$t' = \sin \alpha \sin \delta \cos \sigma + \cos \delta \sin \sigma$$

or

$$t' - \sin \alpha (\sin \delta \cos \sigma) = \cos \delta \sin \sigma$$

If some definite value is assigned to σ , so that $\cos \sigma$ and $\sin \sigma$ become temporarily constants, the equation may be written

$$f_1(u) \cdot f_2(v) \cdot f_3(w) = f_4(w)$$

where $t' = u$, $\alpha = v$, and $\delta = w$. In this form we have an equation of three variables, one of

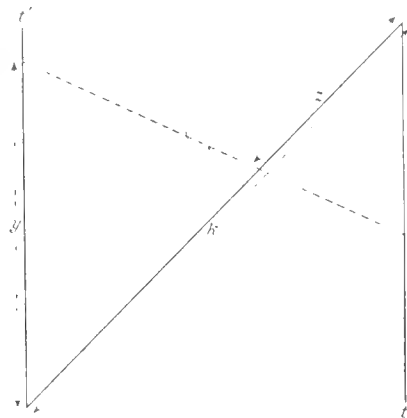

FIGURE 3.—Diagram to illustrate the method of calibrating the diagonal scale of a Z chart.

which (w) occurs on both sides of the equation as two different functions—that is, $f_3(w)$ and $f_4(w)$. Such an equation, when plotted as an alinement chart, will require two parallel straight-line scales and one curvilinear scale. The two parallel straight-line scales, representing the functions $f_1(u)$ and $f_2(v)$, may be drawn and calibrated in the ordinary manner used in building the simpler type of alinement chart, but the curvilinear scale representing the two functions of the variable w must either be projected graphically or computed by some

⁵ Lipka, Joseph, Graphical and mechanical computation, pp. 65-66, New York, 1918.

system of coordinates. The latter procedure is here shown, the solution given by Lipka⁶ being followed very closely.

In figure 4, let α and t' be plotted on two parallel straight lines, as shown; and let δ be represented by some hypothetical curvilinear line. Let the zero point of each of the two parallel scales be connected by a base line, whose length is k ; and let the two outer scales be so placed that this base line lies perpendicular to both. In this way a system of rectangular Cartesian coordinates will be assured. Take for an origin of such a coordinate system the intersection of k with the t' scale. Draw any nomographic index line connecting the α and t' scales and cutting the δ scale. From the intersection of the index line with δ , draw a line parallel to k to meet the α scale and another parallel to the α scale to meet k . From the intersection of the index line with

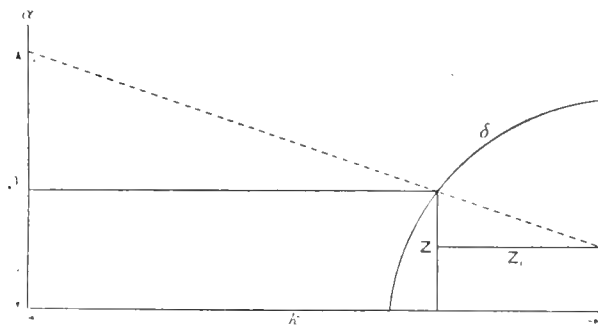

FIGURE 4.—Diagram to illustrate the method of determining the locus of the curvilinear scale in an alignment chart consisting of two parallel straight-line scales and a curvilinear scale.

the t' scale, draw a line parallel to k . In the diagram,

$$y - z : z - x :: k - z_1 : z_1$$

$$z_1 y - z z_1 = k z - k x - z z_1 + z_1 x$$

$$k x - z_1 x + z_1 y - k z$$

$$(k - z_1) x - z_1 y = k z$$

$$x + \frac{z_1}{k - z_1} y = \frac{k z}{k - z_1}$$

This equation is evidently in a form similar to the one to be plotted—that is,

$$f_1(u) - f_2(v), f_3(w) - f_4(r)$$

Therefore, assigning scale moduli of m_1 and m_2 respectively to $f_1(u)$ and $f_2(v)$, we may say that

$$x = m_1 f_1(u) \quad \text{and} \quad y = -m_2 f_2(v)$$

⁶ Lipka, Joseph, op. cit., pp. 199-207.

Then in order to satisfy the equation, it is necessary that

$$\frac{z_1}{k - z_1} = \frac{m_1 f_3(w)}{m_2} \quad \text{and} \quad \frac{k z}{k - z_1} = m_1 f_4(w)$$

Solving the first equation, we find that

$$z_1 = \frac{k m_1 f_3(w)}{m_2 + m_1 f_3(w)} \quad \dots \quad (5)$$

And solving the second equation and substituting in it the value of z_1 from equation (5), we find that

$$z = \frac{m_1 m_2 f_4(w)}{m_2 + m_1 f_3(w)} \quad \dots \quad (6)$$

The values z and z_1 are the rectangular coordinates of any point on the curvilinear scale, representing a definite value of δ , measured from the intersection of k and the t' scale as an origin. The locus of the curvilinear scale δ can then be determined, for a series of assigned values of δ will give the coordinates of a series of points which may be joined together into a smooth curve.

To plot such a curve, however, a fixed value was assigned to the variable σ . Therefore for every assigned value of σ a new curve will result. In the preparation of the chart a series of such curves may be computed for a regular series of values of σ . If only a single curve were charted it would be calibrated in terms of δ , in a way similar to the parallel straight-line scales. But with a series of such curves the points on each curve that represent like values of δ are joined together, forming auxiliary intersecting curves that may be regarded as loci of definite values of δ . The original curves may then be regarded as loci of definite values of σ , and we shall have a series of intersecting curves representing the relationship between the variables δ and σ .

PREPARATION OF CHART.

The complete formula for the thickness of a stratum was charted by the methods here described. (See Pl. VI.) The details of the process have to do mainly with the selection of suitable scale moduli and the selection of such values for the variables s , α , δ , and σ that the resulting scales will have an adequate and balanced calibration.

Little need be said of the preparation of equation (2)—that is, $t = t's$. From the presence of the \pm sign in the general formula it

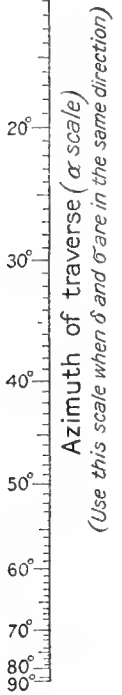
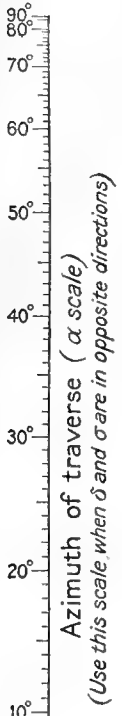

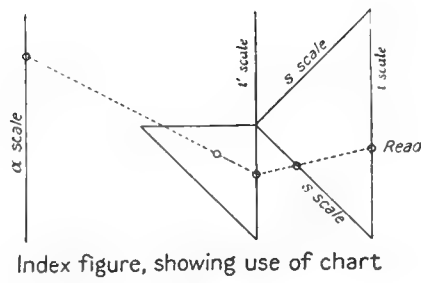

Angle of slope (σ scale)	0°	20°	30°	40°	50°	60°	65°	70°	75°	80°	85°	90°
Angle of dip (δ scale)	90°	70°	60°	50°	40°	30°	25°	20°	15°	10°	5°	0°

INSTRUCTIONS
 Trace values of angle of slope and angle of dip to an intersection in the network. Connect value of α with this intersection by a straight line, using either a straight-edge or a transparent straight-line index, and continue the line to intersect the t' scale. Connect intersection on t' scale with value of slope distance by another straight line, and continue the line to intersect the thickness scale. This last intersection will give the required value of thickness of strata.

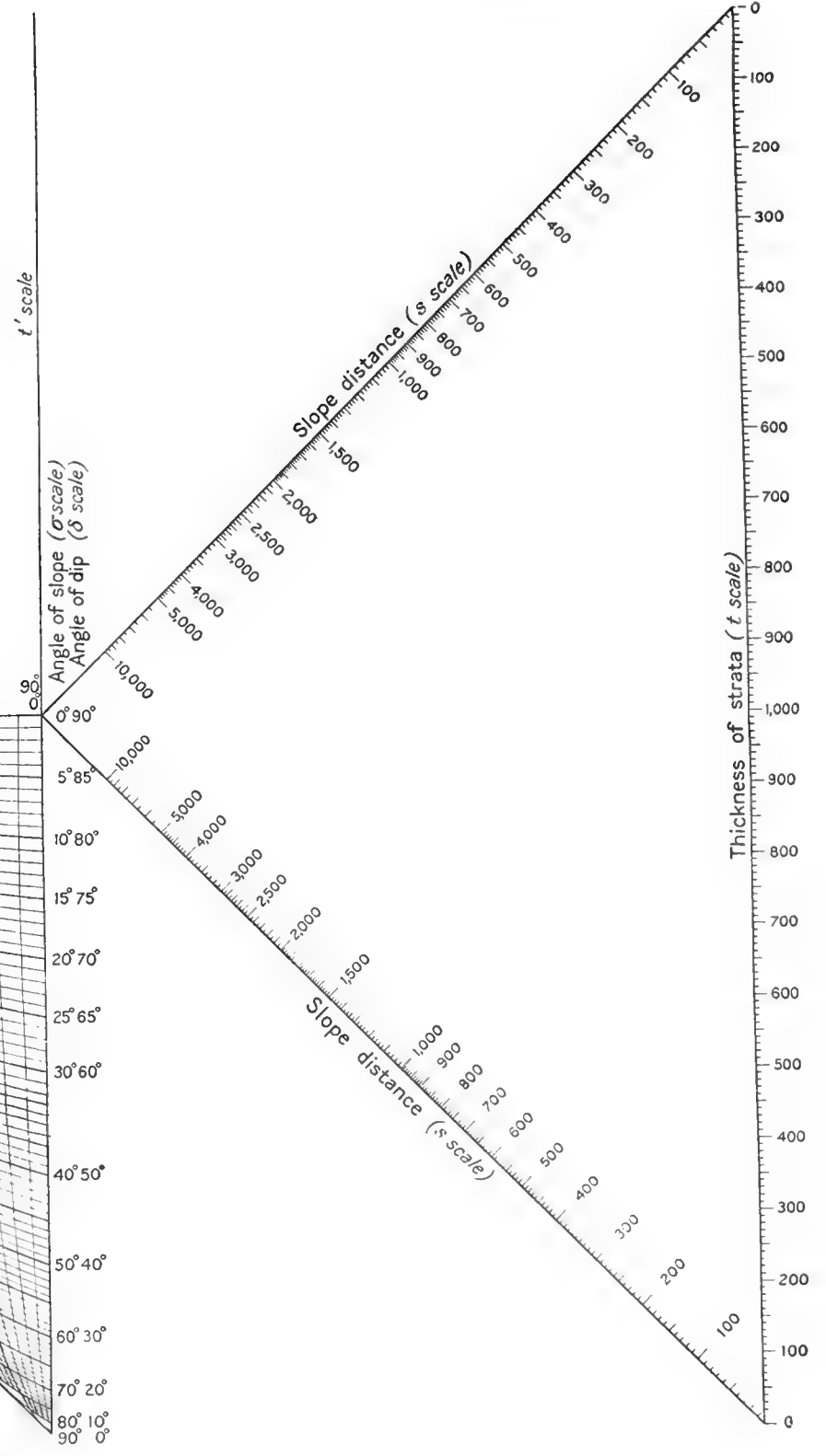

ALINEMENT CHART FOR GRAPHIC COMPUTATION OF THICKNESS OF STRATA.

results that both a positive and a negative scale for both t' and t are required. A scale modulus of 10 was adopted for the original drawing, calculation of the t scale being thus eliminated. The t' scale, though uncalibrated in the finished chart, was calibrated for purposes of projection in the actual work, and the calibration may be shown to be merely a natural sine scale. The scale modulus of 10 likewise eliminated calculation in the preparation of this scale as well as in the preparation of the α scale. The numbers 1, 2, 3, etc., might have been used on the t scale in keeping with slide-rule practice, instead of 100, 200, 300, etc. But as this chart is to be used solely to compute the thickness of geologic strata, it has seemed best to the writer to calibrate the scale in terms of the probable range of answers that will be obtained. The s scale has accordingly been numbered to accord with this convention.

In the plotting of equation (3)—that is, $t' = \sin \alpha \sin \delta \cos \sigma \pm \cos \delta \sin \sigma$ —one point in particular requires explanation. For the positive form of the equation, only positive values of t' will result, but for the negative form of the equation both positive and negative values of t' will be obtained. Hence two nets of δ and σ curves would be required, one with positive and one with negative values; but only a single α scale, the positive one, would be necessary. To avoid drafting these two nets of δ and σ scales, both positive and negative α scales were drawn, and only one δ and σ network. In using the chart, therefore, the positive values of α are used for a solution of the normal or positive form of the general equation, and the negative values of α in solving the negative form of the general equation. This procedure is indicated on the chart.

As stated, the curves of δ and σ will ordinarily be calculated by some system of coordinates and joined together into smooth curves. In the case of this particular equation ($t' = \sin \alpha \sin \delta \cos \sigma \pm \cos \delta \sin \sigma$), however, the compensating form of the functions of δ and σ —that is, $\sin \delta \cos \sigma$ against $\cos \delta \sin \sigma$ —results in a series of curves which are most easily prepared by a projective method. It is unnecessary to go into an analysis of the method, but a statement of the method used is given. It is stated above that a preliminary sine calibration was used on the t' scale. The positive

and negative end points (90° positions) of the α scale being used as points of projection, two series of radiating lines were drawn to the points of sine calibration on the t' scale. The intersection of these two sets of radiating lines gave the loci of the required curves. Each of these curves is tangent to the base of the isosceles triangle that bounds the network, and each emerges to intersect both sides of this triangle. Each curve serves a double purpose, therefore—as a σ curve and as a curve of the complementary value of δ . As it is hard to trace several curves past a rather flat zone of tangency, the curves are doubly named, in order to avoid that necessity. Every curve cuts every other curve, and hence an intersecting point for values of δ and σ can always be found. Only one equivocal condition will be noticed, and that is where complementary values of δ and σ are given as field data. Under this condition, the same curve represents both values, and the point of tangency of the curve with the base of the isosceles triangle must be regarded as the point of intersection of a δ curve and a σ curve—that is, one limb of the curve will be regarded as a δ curve, and the other limb as a σ curve. The σ or angle of slope calibration was carried up to 90° , and this is open to criticism by field geologists, for hillsides of greater slope than 30° are rare. But the chart is also intended for measuring geologic sections in mines as well as in the open, and for this purpose the complete range from 0° to 90° for σ is required.

A small index chart showing five hypothetical points joined by a compound nomographic index line has been added as a guide to anyone using the chart.

USE OF CHART.

The use of the chart (Pl. VI) in obtaining the thickness of geologic strata is simple. At the left side of the chart is the α scale, on which are plotted the azimuth angles between the strike of the rocks and the line of traverse. This calibration comprises both a positive and a negative scale, the positive one starting at the middle of the line and extending upward and the negative one starting at the middle and extending downward. Use the upper scale where the angle of slope and angle of dip are in opposite directions and the lower scale where the angle of slope and angle of dip are in the same direction.

Trace the two lines representing given values of angle of slope and angle of dip to an intersection in the δ - σ gridwork of curves. With a straight edge, or a transparent straight-line index, connect the point on the α scale with the δ - σ intersection, and the continuation of this line will give an intersection on the t' scale. Then connect the intersection on the t' scale with the point on the s scale which represents a given value of slope distance, and the continuation of this line gives an intersection on the t scale, which when read shows the thickness of the strata. It will be noticed that both the t' and t scales are divided into upper and lower parts, just as the α scale is. Also there are two s scales. When the first operation gives an intersection on the upper t' scale the second operation is performed likewise on the upper s and t scales; and conversely when the first operation gives an intersection on the lower t' scale the second operation is performed on the lower s and t scales.

The s and t scales are calibrated 100, 200, 300, etc., instead of 1, 2, 3, etc., because the answers will usually be of that magnitude. If desired, however, these calibrations may be regarded as 1, 2, 3, or 10, 20, 30, or 1,000, 2,000, 3,000, according to the use to which the chart is to be put, just as the ordinary slide-rule calibrations are used.

Another use to which the chart may be put, in addition to finding the thickness of strata, is the solution of equation (1) for any unknown quantity, if the other four are known. Thus, α , σ , s , and t may be known, and it is desired to find δ . A line connecting the t and s scales will intersect the t' scale. If this intersection is connected with the given point on the α scale, the resulting line will intersect the given σ line at a point which when read will show the required value of δ .

DISTANCE TO A STRATUM.

OUTLINE.

It is required to find the length of a tunnel, shaft, or drill hole from some selected point to some definite point on a stratum, when the following data are given:

1. The horizontal and vertical location of the starting point of the tunnel, shaft, or drill hole.
2. The horizontal and vertical location of a second point, which may lie anywhere on the surface of the stratum that is to be intersected.

3. The azimuth angle between the strike of the rocks and the line connecting these two stations.

4. The azimuth angle between the strike of the rocks and the direction of the tunnel, shaft, or drill hole.

5. The angle of dip of the rocks.

6. The angle of dip of the tunnel, shaft, or drill hole.

In connection with Nos. 1 and 2, which may be considered the beginning and end points of a traverse, any two of the following measurements will suffice: (a) Angle of slope between the two stations, (b) difference in elevation between the two stations, (c) slope distance between the two stations, (d) horizontal distance between the two stations. Therefore six sets of data are given, and these, together with the answer (the tunnel distance), will necessarily produce a trigonometric equation of seven variables.

This is the most general form of the problem of distance to a stratum. The problem usually considered by geologists, particularly in oil geology, and referred to as "depth to a stratum," is a special case of the more general problem, wherein the line joining the two points is vertical. In such a case the pitch is 90° and the line joining the two points has no horizontal azimuth angle. In other words, two variables are eliminated. The formula for the general problem will be developed, but for this paper only the formula for the special case—that is, depth to a stratum—will be charted.

GEOMETRIC CONSTRUCTION.

Let S_1 (fig. 5) be the starting point of the tunnel, shaft, or drill hole, and let S_2 be a point which is on the surface of the stratum that is to be intersected but is not in the horizontal plane through S_1 . Let S_1 and S_2 be represented by their projections on the horizontal plane through S_1 and let S_2T be the strike of the stratum at S_2 . The line S_1C , parallel to S_2T , is also the strike line, and AB is any reference line through S_1 in the horizontal plane. Also let h be the horizontal distance from S_1 to S_2 , s the slope distance, e the difference of elevation, σ the vertical angle at S_1 between the horizontal plane and the station point S_2 , and α the azimuth of the line joining S_1 and S_2 with reference to the strike line.

Pass a vertical plane through S_1 and S_2 and revolve this plane about the line joining the projections of S_1 and S_2 into the horizontal plane. The station S_2 will fall on S_2' and the right-angled triangle $S_1S_2S_2'$ will show in true proportions the quantities σ , s , h , and e . Pass a vertical auxiliary plane, perpendicular to the line of strike, through S_2 . Its trace on the horizontal plane is the line P_1 . Lay off S_2S_2'' equal to e and draw $S_2''L'$, making the angle $S_2L'S_2''$ equal to δ , the dip of the stratum at station S_2 . On revolving the right-angled triangle $S_2S_2''L'$ 90° about the line S_2L' and then 90° about the vertical through S_2 , the point L' will fall on L . Through L draw the line LM

The line $T'M$ is the revolved trace of the vertical auxiliary plane through S_1M and the dipping stratum through S_2 , the point K' is the revolved position of the point in which S_1K pierces the inclined stratum, and M' is the revolved position of the point in which the vertical through M cuts the tunnel or drill hole. If the auxiliary plane is revolved back to its original position the projection of K' on the horizontal plane will be found at K , and line DK , drawn parallel to the strike line, is the projection, on the horizontal plane through S_1 of the line in which the dip plane is cut by plane P_2 , the horizontal plane through K .

The distance S_1K' is the length of the tunnel required and is to be derived in terms of the known slope distance s and angles σ , δ , and ρ .

TRIGONOMETRIC FORMULA.

From the figure:

$$S_1K' = \frac{S_1K}{\cos \rho} = (S_1T + TM + MK) \frac{1}{\cos \rho}$$

$$S_1T = \frac{h \sin \alpha}{\sin \beta} = \frac{s \sin \alpha \cos \sigma}{\sin \beta}$$

$$TM = \frac{S_2L}{\sin \beta} = \frac{e}{\tan \delta} \cdot \frac{1}{\sin \beta} = \frac{s \sin \sigma}{\sin \beta \tan \delta}$$

$$MK = M'K' \cos \rho = \frac{MM' \cdot HM}{T'H} \cos \rho$$

$$\begin{aligned} \text{but } MM' &= S_1M \tan \rho = (S_1T + TM) \tan \rho \\ &= \left(\frac{s \sin \alpha \cos \sigma}{\sin \beta} + \frac{s \sin \sigma}{\sin \beta \tan \delta} \right) \tan \rho \\ &= \frac{s \tan \rho}{\sin \beta \tan \delta} (\sin \alpha \tan \delta \cos \sigma + \sin \sigma) \end{aligned} \quad (a)$$

$$HM = \frac{TM}{\cos \rho} = \frac{s \sin \sigma}{\sin \beta \tan \delta \cos \rho} \quad (b)$$

$$\begin{aligned} T'H &= e - HT = s \sin \sigma - TM \tan \rho \\ &= s \sin \sigma - \frac{s \sin \sigma}{\sin \beta \tan \delta} \tan \rho \\ &= \frac{s \sin \sigma}{\sin \beta \tan \delta} (\sin \beta \tan \delta - \tan \rho) \end{aligned} \quad (c)$$

Then by substitution from equations (a), (b), and (c).

$$MK = \frac{s \tan \rho}{\sin \beta \tan \delta} \cdot \frac{\sin \alpha \tan \delta \cos \sigma + \sin \sigma}{\sin \beta \tan \delta - \tan \rho}$$

From the values of S_1T , TM , and MK just found

$$\begin{aligned} S_1T + TM &= \frac{s \sin \alpha \cos \sigma}{\sin \beta} + \frac{s \sin \sigma}{\sin \beta \tan \delta} \\ &= \frac{s}{\sin \beta \tan \delta} (\sin \alpha \tan \delta \cos \sigma + \sin \sigma) \\ MK &= \frac{s \tan \rho}{\sin \beta \tan \delta} \cdot \frac{\sin \alpha \tan \delta \cos \sigma + \sin \sigma}{\sin \beta \tan \delta - \tan \rho} \end{aligned}$$

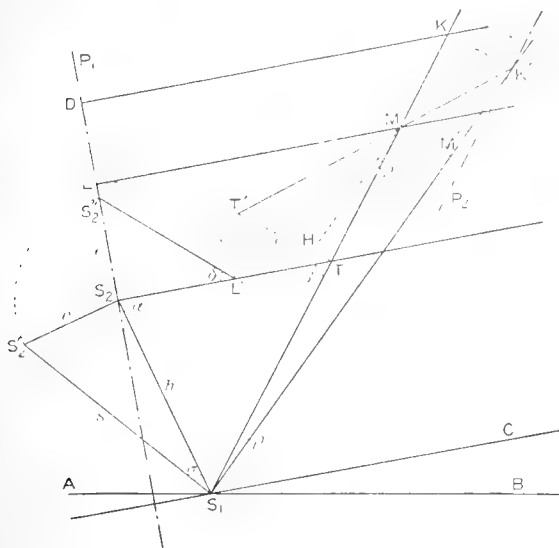

FIGURE 5.—Geometric representation of the distance to a stratum when the dip of the stratum, the position of a point on the stratum relative to the starting point of measurement, and the horizontal and vertical directions of the line of measurement are given.

parallel to the strike line. The line LM is the line in which the dipping stratum intersects the horizontal plane through S_1 , and the strike line S_2T is the line of intersection of the dipping plane with the plane through S_1C and the station S_2 .

Let S_1K be the projection of any sloping tunnel or drill hole which makes an angle ρ with the horizontal plane and has an azimuth β with reference to the strike line. Through S_1K pass a vertical plane. This plane will cut the strike line S_2T in point T and the line LM in point M . If we revolve this plane about S_1M into the horizontal plane, the point T , whose distance above the horizontal plane is e , will fall at T' , M will be unmoved, and S_1K' will be the revolved position of the tunnel or drill hole. The angle ρ will be shown in true value. Draw the line $T'M$, cutting S_1K' in K' .

Adding these two last equations and factoring, we get

$$S_1 K = s (\sin \alpha \tan \delta \cos \sigma + \sin \sigma) \frac{1}{\sin \beta \tan \delta - \tan \rho}$$

and as

$$S_1 K' = \frac{S_1 K}{\cos \rho}$$

Therefore

$$S_1 K' - s (\sin \alpha \tan \delta \cos \sigma + \sin \sigma) \left. \begin{array}{l} 1 \\ \cos \rho (\sin \beta \tan \delta - \tan \rho) \end{array} \right\}$$

By means of a similar though simpler construction it may be shown that the formula for "depth to a stratum" is $d = s (\sin \alpha \tan \delta \cos \sigma + \sin \sigma)$, in which the term $\sin \sigma$ is positive or negative as is determined by the value of σ . It therefore appears that the expression

$$\frac{1}{\cos \rho (\sin \beta \tan \delta - \tan \rho)}$$

in the equation for the value of d is a factor which must be applied where the hole is other than vertical. If the hole or shaft is vertical this factor reduces to unity.

In the construction above given, the angles σ and δ have been drawn in opposite directions, and also the angles σ and ρ in opposite directions. It has been found that four different formulas can result by the use of other constructions, and the composite formula covering all cases is as follows:

$$d = s (\sin \alpha \tan \delta \cos \sigma \pm \sin \sigma) \left. \begin{array}{l} 1 \\ \cos \rho (\sin \beta \tan \delta \pm \tan \rho) \end{array} \right\} \dots (7)$$

The following rules govern the use of this composite formula:

- Use $+$ $\sin \sigma$, when σ and δ are in opposite directions.
- Use $-$ $\sin \sigma$, when σ and δ are in the same direction.
- Use $+$ $\tan \rho$, when σ and ρ are in opposite directions.
- Use $-$ $\tan \rho$, when σ and ρ are in the same direction.

GRAPHIC REPRESENTATION OF THE FORMULA.

As stated before, only that part of formula (7) which relates to the measurement of "depth to a stratum" will be plotted here. The whole formula could be plotted by the same methods, but in this paper other methods will be given for its solution.

Consider the formula $d = s (\sin \alpha \cos \sigma \tan \delta \pm \sin \sigma)$. This may be split into two formulas, like equation (1), and plotted by the same methods. Inserting an auxiliary variable t' , we have

$$t' = \frac{d}{s} \dots \dots \dots (8)$$

$$t' = \sin \alpha \cos \sigma \tan \delta \pm \sin \sigma \dots \dots (9)$$

These two equations have been plotted exactly as equation (1) was plotted, and the result is shown on Plate VII. The two charts, Plates VI and VII, are analogous in every respect, and no further explanation is required.

USE OF CHART.

The depth to a stratum is computed from the chart (Pl. VII) exactly as the thickness of strata is computed from Plate VI. All directions are identical.

GRAPHIC SOLUTION OF RIGHT TRIANGLE.

OUTLINE.

In the consideration of the two preceding problems of thickness of strata and distance

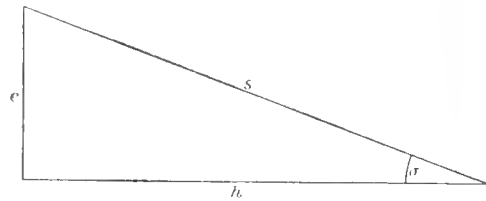

FIGURE 6.—Right-angled triangle showing the relations of slope distance, horizontal distance, difference of elevation, and vertical angle between two station points.

to a stratum, it has been assumed, in the right triangle determined by the two stations S_1 and S_2 and the plane of reference (see fig. 6) that the slope distance and angle of slope were given. It may be, however, that instead of s and σ any one of the five additional combinations is given as follows: σ and h , σ and e , s and h , s and e , or h and e . It is desired to derive graphically the values of s and σ when any of these combinations are given.

TRIGONOMETRIC FORMULAS.

It may be seen at a glance that the solution of this problem is essentially a graphic representation of the sine, cosine, and tangent conditions of a right triangle. The formulas involved are as follows:

$$e = s \sin \sigma \dots \dots \dots (10)$$

$$h = s \cos \sigma \dots \dots \dots (11)$$

$$e = h \tan \sigma \dots \dots \dots (12)$$

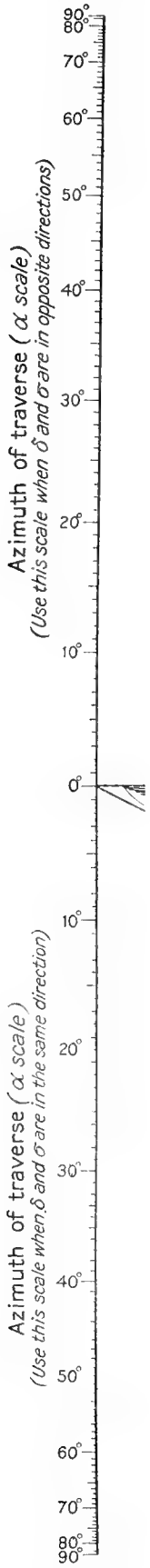

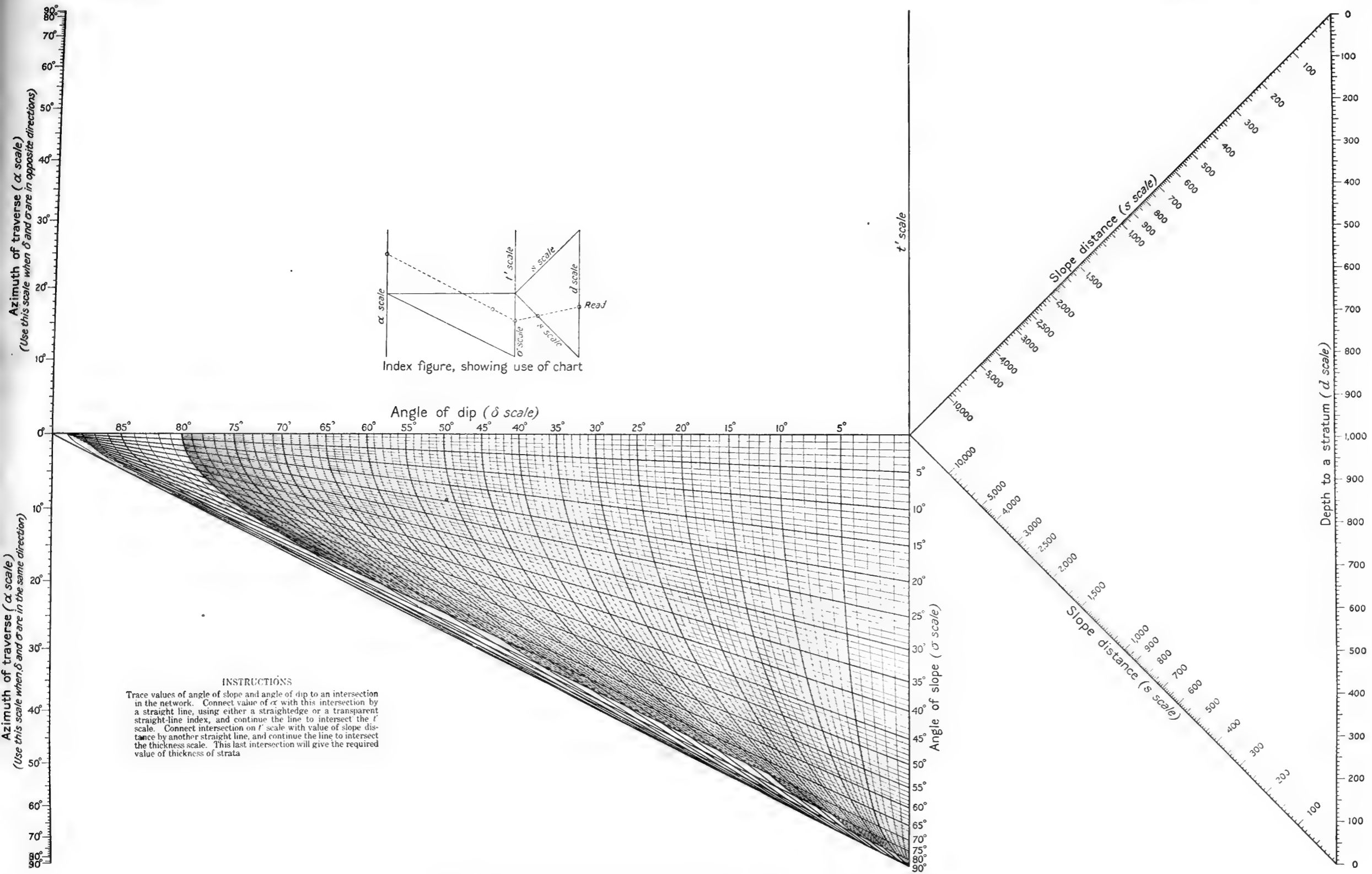

INSTRUCTIONS

Trace values of angle of slope and angle of dip to an intersection in the network. Connect value of α with this intersection by a straight line, using either a straightedge or a transparent straight-line index, and continue the line to intersect the t scale. Connect intersection on t scale with value of slope distance by another straight line, and continue the line to intersect the thickness scale. This last intersection will give the required value of thickness of strata.

ALIGNMENT CHART FOR GRAPHIC COMPUTATION OF DEPTH TO A STRATUM.

Each of these equations is in such form that it may be written $f_1(u) = f_2(v) \cdot f_3(w)$, and as shown before such equations are best plotted by means of the Z type of alinement chart.

PREPARATION OF CHART.

The method of plotting such equations has already been described, in connection with the

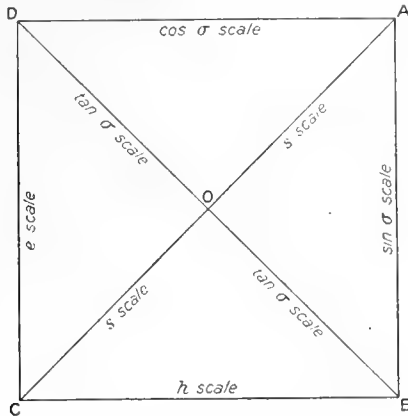

FIGURE 7.—Diagram illustrating the combination of three alinement charts for the solution of right-angled triangles.

plotting of equation (2). Two straight-line parallel scales, oppositely directed, are used to plot $f_1(u)$ and either of the other two variables, in this instance $f_3(w)$. Both of these are natural scales. A straight line joining the zero ends of these two scales carries the scale of the third variable, $f_2(v)$, and the calibrations are calculated by means of equation (4), as already explained.

In order to plot in one diagram all three of these equations, it is necessary to use one or more of the same scales in different solutions. Equations (10) and (11) have in common the variable s , wherefore it has seemed best to make a common scale of s , in the solution of these two formulas. In figure 7 the values of e are plotted on CD, the values of $\sin \sigma$ on AB, and the values of s on the diagonal joining the zero ends of these two scales. Two other lines, however, AD and CB, may be drawn to complete the square, and on these the values respectively of $\cos \sigma$ and h may be plotted. In this way a chart composed of five lines is provided for the plotting of e , h , s , $\sin \sigma$, and $\cos \sigma$.

The chart is now complete except for the solution of equation (12), which expresses the tangent condition. For this, the scales e and h , already plotted, are used in conjunction with a scale of $\tan \sigma$ which is plotted on the line BD. An index of two lines intersecting at right angles is used, such as EG and FH (figure 8). The method consists in passing the line EG through the given points on the e and h scales and then sliding the index along EG until the line FH passes through C. In this position the angle $DCF = \sigma$, and it is required to compute a calibration of $\tan \sigma$ on the line DB so that a reading indicated by the line HF on DB will give the required value of σ .

In figure 8

$$\begin{aligned}
 &DC : DS : \sin (135^\circ - \sigma) : \sin \sigma \\
 DS &= \left. \begin{aligned} &\frac{DC \sin \sigma}{\sin (135^\circ - \sigma)} = \frac{DC \sin \sigma}{\sin (45^\circ + \sigma)} \\ &= \frac{DC}{\sin 45^\circ} \cdot \frac{\sin \sigma}{\sin \sigma + \cos \sigma} \end{aligned} \right\} \\
 DS &= DB \cdot \frac{\sin \sigma}{\sin \sigma + \cos \sigma} \dots \dots (13)
 \end{aligned}$$

Therefore the $\tan \sigma$ calibration, expressed in the diagram by successive values of DS, was

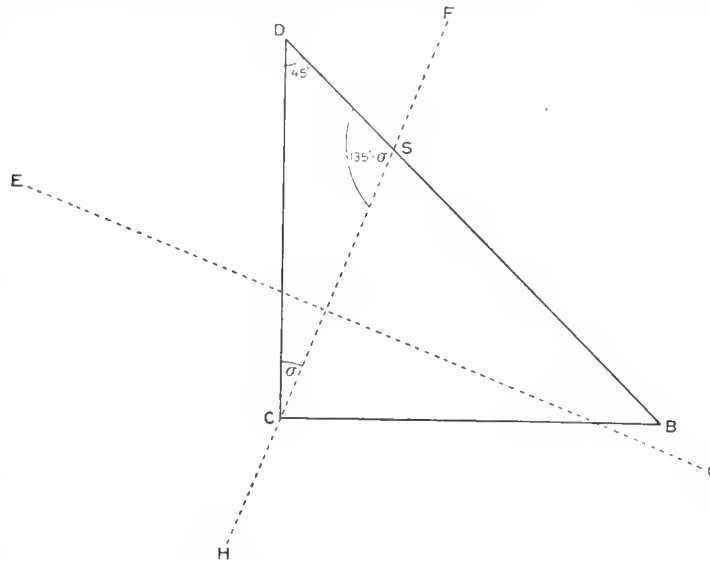

FIGURE 8.—Diagram illustrating the use of an alinement chart for the solution of the tangent condition in right-angled triangles.

computed by multiplying the length of the diagonal DB by the expression $\frac{\sin \sigma}{\sin \sigma + \cos \sigma}$.

The chart representing the complete solution of a right-angle triangle is shown in Plate VIII. It is of universal use in the

graphic solution of right triangles, but it is here presented as an accessory chart, to be used in connection with the charts shown in Plates VI and VII. Three small index diagrams have been added as guides in the use of the chart. For the convenience of geologists, for whom this chart has been primarily constructed, the terms vertical distance, horizontal distance, slope distance, and angle of slope have been placed on the chart to prevent ambiguity in its use. Also as in the preceding charts, the calibrations are given as 100, 200, 300, etc., instead of 1, 2, 3, etc., for reasons stated on page 45.

USE OF CHART.

A straight edge or, better still, a piece of transparent or semifrosted celluloid with a black line ruled on the underside is required to solve equations (10) and (11). If, for example, σ and h are given, connect the σ value on AD (fig. 7) with the h value on BC, and the intersection on AC will give the value of s . Or if σ and s are given, connect the σ value on AD with the s value on AC, and the continuation of this line intersecting BC will give the value of h on BC. Similar solutions are used when e , s , and σ are involved. For equation (12) a piece of transparent or semifrosted celluloid will be required, on the underside of which are drawn two black lines intersecting at right angles. One of these lines is placed to pass through the given values of e and h , on CD and BC, respectively, and the other required to pass through the point C. Then the continuation of the line passing through C will show on DB the value of σ .

TRIGONOMETRIC COMPUTER.

OUTLINE.

Two good reasons exist for the use of a trigonometric computer. First, the geologist or surveyor will have numerous formulas to solve which, though essential, are not frequently used. It would be impracticable to have an alignment chart for every such formula, and it would be a laborious task to prepare so many such charts. Second, such charts, when reduced to a size which can be carried in the field, might not give sufficiently accurate results, particularly when the formulas are complex.

The alternative is some graphic computing device, which is accurate enough for general

purposes and compact enough to be carried without difficulty in the field. The straight slide rule at once suggests itself as an instrument for this purpose, but it is open to two main objections—it is not of convenient shape to be easily and safely carried, and it is not easy to use for the solution of trigonometric formulas.

To fill this distinct want, the writer has designed a circular slide rule, which will not exceed five inches in diameter nor one twenty-fifth of an inch in thickness, which will be the equivalent in accuracy of a 12-inch straight slide rule, and which can easily be carried in a notebook, just as a protractor is carried. The principal practical advantages of this type of computer may be summarized thus:

1. It is compact and portable.
2. It enables all computations, including trigonometric computations, to be accomplished with the same ease and by exactly the same operations.
3. It possesses a continuous scale, so that it is never necessary to reset the instrument, as it is with the straight slide rule, because the answer may be off the scale.
4. Sufficient space is available through the use of concentric circles, or of a spiral, to plot the entire tangent scale, only half of which is plotted on the straight slide rule. This makes possible a direct setting to the tangents of angles between 45° and 90° and to the cotangents of angles between 0° and 45° , doing away with the necessity of computing these values from reciprocals, as in the straight slide rule.

CONSTRUCTION OF COMPUTER.

A circular slide rule is constructed in exactly the same way as a straight slide rule, except that the calibration is computed and laid off in angular instead of linear magnitudes. In constructing a straight slide rule x inches long, for multiplication and division, which is to range from a scalar value of y at one end to a scalar value of z at the other end, the scale modulus (M) is expressed as follows:

$$M = \frac{x}{\log y - \log z}$$

The calibration is computed by multiplying the logarithms of each scalar value that will appear on the scale by M.

For a circular or spiral slide rule, consider a circle of indeterminate diameter depending on

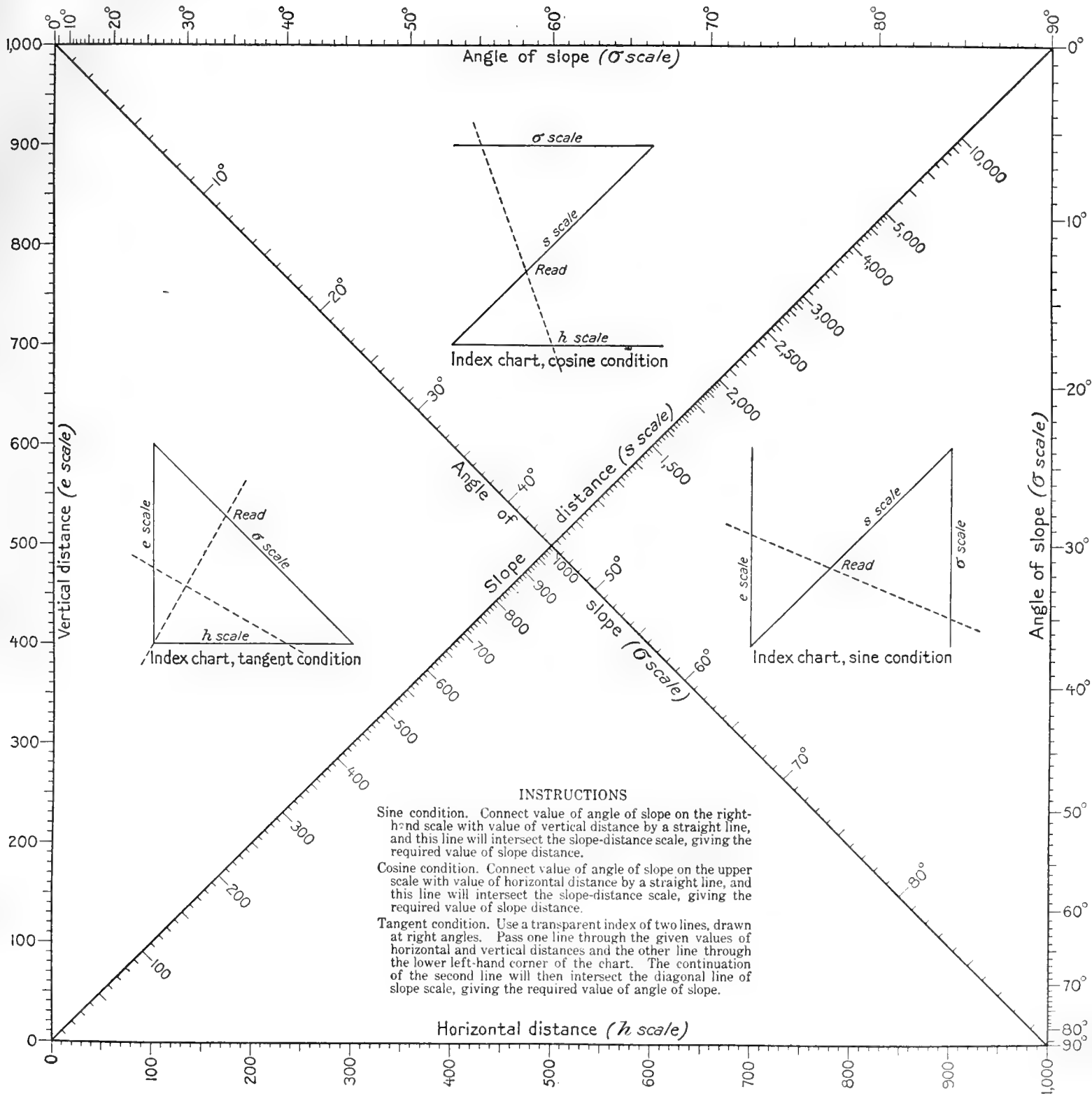

INSTRUCTIONS

- Sine condition.** Connect value of angle of slope on the right-hand scale with value of vertical distance by a straight line, and this line will intersect the slope-distance scale, giving the required value of slope distance.
- Cosine condition.** Connect value of angle of slope on the upper scale with value of horizontal distance by a straight line, and this line will intersect the slope-distance scale, giving the required value of slope distance.
- Tangent condition.** Use a transparent index of two lines, drawn at right angles. Pass one line through the given values of horizontal and vertical distances and the other line through the lower left-hand corner of the chart. The continuation of the second line will then intersect the diagonal line of slope scale, giving the required value of angle of slope.

ALINEMENT CHART FOR THE GRAPHIC SOLUTION OF RIGHT TRIANGLES.

the size desired for the finished product. Angular magnitudes are to be plotted, and as a circle is measurable in degrees, the same formula applies if x is considered to be the angular extent of the scale. If several concentric circles or a spiral of several turns is used to plot some one function, the circular scale modulus is expressed thus:

$$M = \frac{t \ 360}{\log y - \log z}$$

where t is the number of concentric circles or the numbers of turns in the spiral.

The circular slide rule here considered was computed with a circular scale modulus of 180 instead of 360. The logarithmic range from 1 to 10 is 1, but the logarithmic range from $\sin 90^\circ$ to $\sin 0^\circ 45'$ is almost 2, and it therefore requires twice as long a scale to plot the desired range of sines as to plot the usual numerical scale. If the numerical scale is plotted to a whole turn (360°), the sine range will require two turns, and if an answer is to be read off in sines, it will be ambiguous, as the index will give two possible values. To avoid this result an angular range of 180° was used for the numerical scale, which places the entire sine scale in one turn. The usual numerical calibration therefore takes but half of one turn, and to prevent the index from yielding an answer in the uncalibrated half of the number scale, the numerical range was doubled—that is, to read from 0.01 to 1, or from 0.1 to 10, as desired. Such a scale therefore takes a whole turn.

The tangent scale, if plotted with the same angular range as the sine scale, requires twice as long a scale as the sine scale, and in order to obtain this range the tangent scale is plotted in a two-turn spiral, the same circular scale modulus being used as before. As a result,

any answer that is read off in tangents will theoretically be ambiguous, as the index gives two values, but practically the ambiguity is of no consequence, for the two values given by the index are so widely different that the operator, if he knows roughly the magnitude of the required answer, will be able to choose without difficulty the proper one.

The calibration of this computer is shown in figure 9. The outer circle is the number scale; the next circle inward is the sine scale; and the tangent scale is placed inside the sine scale in a two-turn spiral. This disk is mounted to turn upon an underlying support which extends outward a quarter of an inch or more and is equipped with two overlying indexes, made of transparent celluloid, which are attached to the center of the disk. One of these indexes

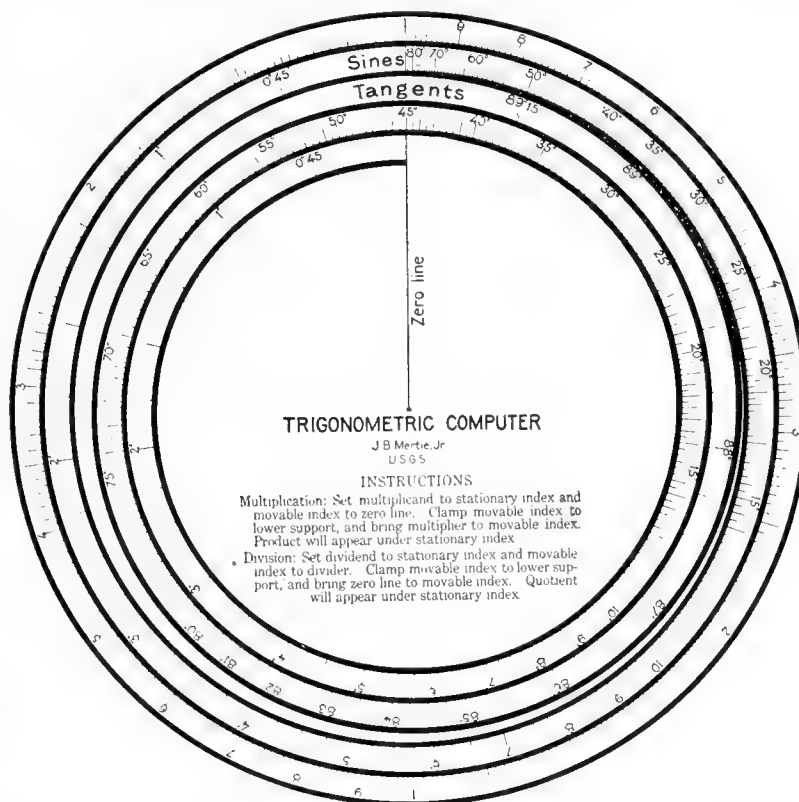

FIGURE 9.—Trigonometric computer for the solution of such problems as are readily solved with the 12-inch straight slide rule.

turns freely, but the other is attached at the outside to the underlying support and is therefore immovable. It is intended that the freely moving index may be attached temporarily to the underlying support by pressure with the thumb and one finger.

USE OF COMPUTER.

It is easy to remember how to manipulate this computer, because both in multiplication and division the start is made at the stationary index, and the answer is found at the same place. Thus, in multiplication the multiplicand is set under the stationary index; the movable index is set to the zero line of the scale; and then, the movable index being clamped to the underlying support with the thumb and finger, the multiplier is brought under the movable index; the product is then found under the stationary index. In division, the dividend is set under the stationary index, and the movable index is set to the divider and clamped; the zero of the scale is then brought to the movable index, and the quotient appears under the stationary index.

The computer also enables the operator to read natural sines and tangents to at least three digits, and by using complementary angular values he can read the natural cosines and cotangents. Secants and cosecants, though rarely used, may be obtained by taking the reciprocals respectively of cosines and sines.

As before stated, there is a twofold numerical range from 0.01 to 1 or from 0.1 to 10. In multiplying numbers by numbers, it is immaterial which of these scales is used; in fact, a multiplicand can be selected in one and a multiplier in another, and the product will be correct. In multiplying numbers by trigonometric functions, however, the true meanings of these two number scales must be utilized if the required answer is to be read as a trigonometric function. These two scales in reality represent any two number scales with a logarithmic range of 1, in which the calibrations of one are ten times the value of the calibrations in the other. This condition is not unique to this computer, being present in all duplex slide rules, but is mentioned here merely to prevent possible confusion in the use of the computer.

It is recommended that the computer be used in the field for all computations, thus saving the carrying of graphic charts or of a book of logarithm tables. The computer is in effect a graphic table of three-place logarithms arranged for general computations.

STRATIGRAPHIC SECTIONS IN SOUTHWESTERN UTAH AND NORTH- WESTERN ARIZONA.

By JOHN B. REESIDE, jr., and HARVEY BASSLER.

INTRODUCTION.

The stratigraphic data contained in this paper were gathered in the autumn of 1919 during the course of a reconnaissance of part

as the stratigraphy of the region has features of general interest it has seemed worth while to record our observations, though they are somewhat scattered.

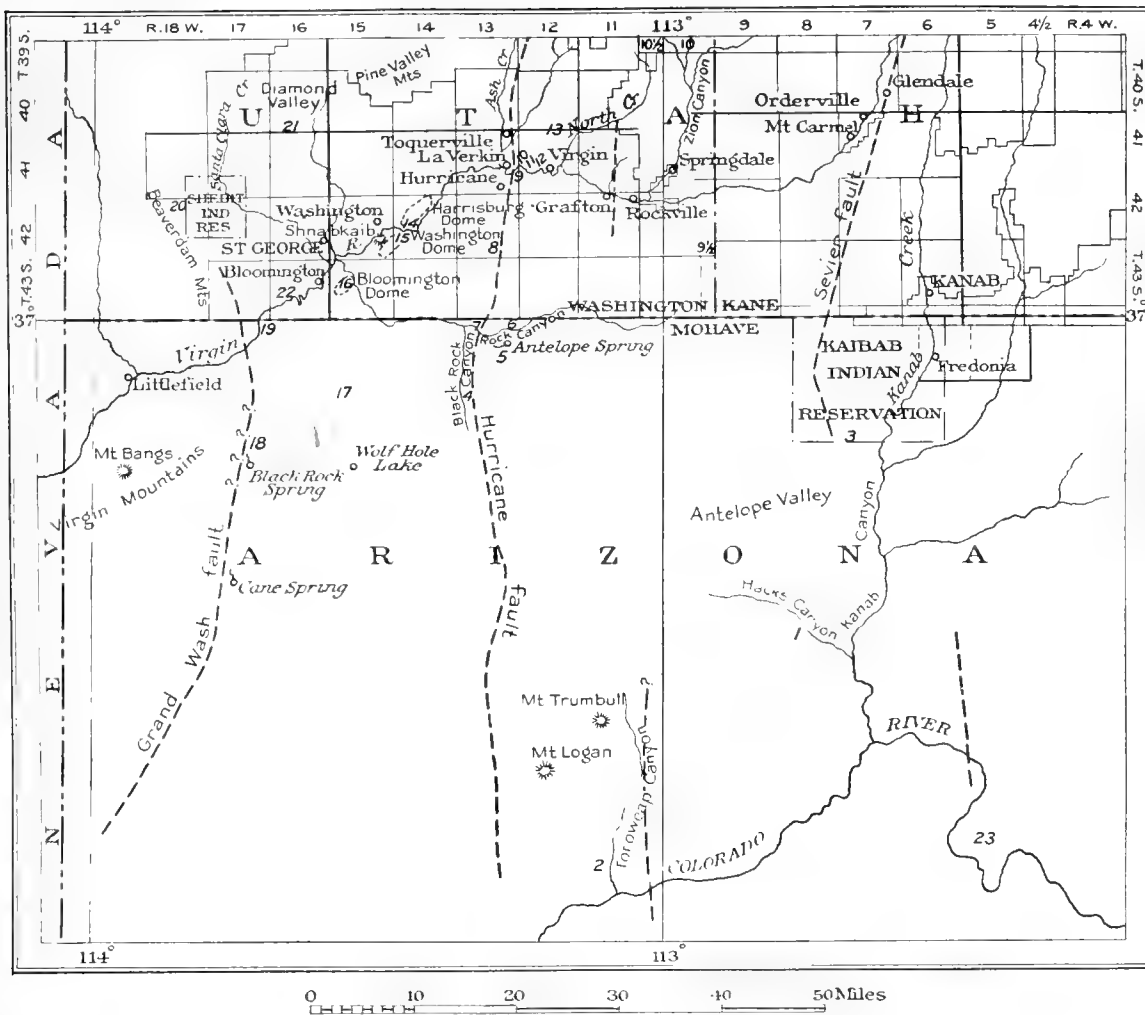

FIGURE 10.—Map showing localities where sections were measured in Washington County, Utah, and Mohave County, Ariz.

of Washington County, Utah, and Mohave County, Ariz., made chiefly to procure information as to the possibility of the occurrence of petroleum in that region. As very few detailed data on the stratigraphy of the region are available in published literature and also

Washington County lies in the extreme southwest corner of Utah, and Mohave County in the extreme northwest corner of Arizona. The region is part of the Colorado River drainage basin—in fact, it might be considered to be within the northern confines of the Grand

Canyon district. It contains deeply dissected areas in which the rocks are well exposed. The climate is arid, but farming by irrigation is very successful. Along Virgin River and its few perennial tributaries settlements are fairly numerous, but away from the streams there are none. St. George, the largest town in the region and the seat of Washington County, has about 2,000 inhabitants. Other smaller settlements are shown on the map (fig. 10).

STRUCTURE.

The dominating structural features of the region are the north-south faults of the Great Basin system. The famous Hurricane fault crosses it (see fig. 10) and, it is believed, the

Grand Wash fault also. Other unnamed minor faults are present. One prominent fold, known as the Virgin anticline, extends northeastward from the district a few miles south of St. George almost to the Hurricane fault—a distance of approximately 15 miles. On this anticline cross folds have formed three domes known as the Harrisburg dome, Washington dome, and Bloomington dome. Other minor folds occur here and there but are relatively unimportant elements in the general structure of the region.

STRATIGRAPHY.

GENERAL SECTION.

The rocks of the region are classified in this paper as follows:

Geologic formations of southwestern Utah and northwestern Arizona.

System.	Series.	Formation.	Member.	Character of rocks.	Thickness (feet).
Quaternary.				Alluvium, dune sand, etc.	
				Basalt flows with associated boulder beds and cinder cones.	
Tertiary(?).				Massive yellow sandstone with some pink staining, separated by soft sandstone, much of it red, and red shale. The series as a whole is pink.	1,500+
				Buff sandstones with some intercalated shale.	1,000±
Cretaceous(?).				Variegated shale, with a little thin limestone in upper part and some platy limestone in lower part.	140
				Greenish-gray, cream-colored, and brown fossiliferous marine limestone, underlain by brick-red sandstone, shale, and gypsum.	460±
Jurassic.				Massive cross-bedded sandstone, red in lower part and white above, the boundary between the colored parts varying in position from a level near the middle to the top.	2,100

Geologic formations of southwestern Utah and northwestern Arizona—Continued.

System.	Series.	Formation.	Member.	Character of rocks.	Thickness (feet).	
Triassic.	Upper Triassic.	Chinle formation.		Brick-red to deep-red shale and sandstone.	200	
				Massive medium-grained mauve sandstone, cross-bedded and ripple-marked.	90	
				Brick-red sandstone and shale.	420	
				Variable coarse arkosic cross-bedded sandstone, banded with gray, white, and mauve and containing fossil wood. Locally known as the "Silver Reef sandstone."	25	
				Variegated "gumbo" clay shale, bluish gray, greenish gray, mauve, red, and rarely brown; contains fossil wood.	260	
				At top 20 feet of gray platy sandstone, underlain by 20 feet of gray and green shale with some fossil wood; at base 75 feet of brown sandstone, with lenses and lenses of pebbles of chert, quartz, silicified wood, and rarely igneous rock; fossil logs abundant.	115	
		Upper Triassic(?).	Shinarump conglomerate.			
		Lower Triassic.	Moenkopi formation.		Brick-red to deep-red and brown shale and sandstone; upper part very dark; locally contains massive beds of yellow medium-grained sandstone.	475±
				Shnabkaib shale member.	Gray to white sandy shale and soft sandstone, with some pink layers and much gypsum.	360-630
				Virgin limestone member.	Red beds similar to those underlying the Virgin limestone member.	435±
				Three layers of earthy yellow limestone separated by yellow and red calcareous shale.	11-160	
			Red to brown shale and sandstone, with soft tan sandstone near base and layers, streaks, and veinlets of gypsum throughout.	360±		
			Rock Canyon conglomeratic member.	Variable assemblage of shale, limestone, gypsum, conglomerate, and a minor amount of sandstone.	0-288	

Geologic formations of southwestern Utah and northwestern Arizona—Continued.

System.	Series.	Formation.	Member.	Character of rocks.	Thickness (feet).
Carboniferous.	Permian.	Kaibab limestone.	Harrisburg gypsiferous member.	Gypsum, shale, and limestone, with platy chert. Locally the "Bellerophon limestone" at top.	0-280±
				Massive cliff-forming cherty gray limestone, with locally a thick limestone breccia in lower part.	185-455
				Soft beds resembling basal member.	80-285
				Massive gray limestone with much chert.	150-230
				Gypsum, gray and yellow shale, soft gray sandstone, and some thin-bedded dark-drab limestone.	0-100
	Permian (?)	Coconino sandstone.		Deep-yellow to buff sandstone at top locally; massive white friable sandstone in middle; pale-yellow sandstone below.	90±
	Pennsylvanian (?)	Supai formation.		Brick-red sandstone and shale in the southeastern part of the region, changing northwestward into a yellow massive sandstone with only patches of pink color.	1,300-1,500
	Pennsylvanian.	Redwall limestone.		Dense siliceous gray limestone, with some sandstone layers; mostly heavy bedded; light gray on fresh surface, dark gray and brown on weathered surface.	1,500±
	Mississippian.				

As the field work dealt chiefly with the formations between the Redwall limestone and the Shinarump conglomerate the larger part of this paper pertains to them. The fossils collected all came from the Kaibab limestone and from the Rock Canyon conglomeratic member and Virgin limestone member of the Moenkopi formation. They were submitted to G. H. Girty for examination, and the identifications supplied by him, as well as a statement of their bearing on the stratigraphy, are included in the appropriate places.

REDWALL LIMESTONE.

The Redwall limestone was seen in the Virgin River narrows (section 19, p. 75) below St. George, where more than 500 feet of it is exposed east of a fault on the east side of Heber Valley. It is a dense siliceous gray limestone

with some sandstone layers, mostly heavy-bedded, light gray on the fresh surface and red-brown and dark gray on the weathered surface. About 200 feet beneath the top there is a thin-bedded, very dark gray, highly silicified limestone layer 20 feet thick. This rock has been thought by the residents of the region to contain petroleum, but it does not respond favorably to any tests. A few fragmentary fossils were seen but none collected. The correlation with the Redwall limestone of the Grand Canyon district is made on stratigraphic position and lithology.

The limestone was examined again at a locality 2 miles north of the Apex copper mine and about 20 miles west of St. George (section 20, p. 76), near the pass where the Arrowhead Trail to Los Angeles cuts through the Beaverdam Mountains. In this locality the upper

part of the formation has been altered locally by mineralizing solutions and bears deposits of copper of commercial value.¹ Below this soft, porous altered zone the beds consist of hard limestone apparently somewhat less massive and less silicified than the beds in the Virgin River narrows, with a few rather heavy beds of calcareous sandstone near the top that are very similar to the beds of calcareous sandstone and arenaceous limestone seen at the top of the Redwall limestone on the rim of the Grand Canyon at the mouth of Toroweap Valley. The thickness was not determined but is more than 1,500 feet.

Longwell² divided the limestones beneath the Supai sandstone in the Muddy Mountains of Nevada into three formations. The uppermost, the Callville limestone, contains Pennsylvanian fossils and may in part represent what is here called Redwall limestone.

SUPAI FORMATION AND COCONINO SANDSTONE.

The names Supai formation and Coconino sandstone were applied by Darton³ to parts of the "Aubrey sandstone" of the earlier students of the region. In the Shinumo quadrangle, Ariz.⁴ (see fig. 10, locality 23), the Supai formation consists of hard fine-grained cross-bedded red sandstone with interbedded red shale and, in the lower 100 feet, interbedded limestone, the whole series 850 feet thick, overlain by soft red shaly sandstone and red shale 400 feet thick, a total thickness of 1,250 feet for the formation. It is locally as much as 1,400 feet thick. The Supai formation is overlain by the Coconino sandstone, a massive buff to creamy-white sandstone, very fine and even grained and apparently in a single bed 250 to 350 feet thick.

In Kanab and Hacks canyons (section 1, p. 69) the Supai formation is composed entirely of brick-red sandstone and shale more than 1,100 feet thick. In the upper part of Hacks Canyon the Coconino sandstone consists of a massive white friable saccharoidal sandstone with a deep-yellow to buff sandstone above it and a pale-yellow sandstone beneath, the

whole formation 90 feet thick. The upper deep-yellow member is present only in the upper part of the canyon, wedging out at a point about 6 miles from the mouth of the canyon on Kanab Creek. In Toroweap Canyon (section 2, p. 69) the Supai formation is all red and 1,300 feet thick, and the Coconino shows an upper deep-yellow layer, a middle whitish layer, and a lower paler-yellow layer, the whole 96 feet thick. In Black Rock Canyon (section 4, p. 70) the Coconino and Supai were not differentiated, but an exposure of 1,200 feet contains mainly yellow beds separated in the interval from 200 to 500 feet beneath the top by soft brick-red sandstones. At the mouth of Rock Canyon (section 7, p. 71) an exposure of 500 feet of sandstone shows mingled red and yellow beds except for the upper 17 feet, which contains the apparent equivalent of the Coconino—an upper deep-yellow bed, a middle white bed, and a lower yellow bed. At the locality 6 miles south of Hurricane (section 8, p. 71; Pl. IX, A, B) an exposure of 250 feet of sandstone is mostly yellow, but the upper 65 feet contains an upper yellow layer 20 feet thick underlain by a white sandstone 45 feet thick, which may represent the Coconino sandstone. In Virgin Narrows (section 19, p. 75) the Supai is a massive sandstone 1,450 feet thick with considerable irregular red staining in the middle part. The color of the staining is not a deep red and at many points is really a pink. The 45 feet of beds above this unit consist of an upper deep-yellow sandstone, a middle white sandstone, and a lower cream-colored sandstone and probably represent the Coconino sandstone. In the section on the Arrowhead Trail through the Beaverdam Mountains (section 20, p. 76) the Coconino and Supai are represented by a very massive sandstone 1,400 feet thick that is predominantly of a pale-yellow color with local pinkish patches. In brief, the red shale and sandstone of the typical Supai formation and the typical white Coconino sandstone gradually change toward the northwest into a massive yellow sandstone with no real red and only a little pink coloring. The total thickness of sandstone seems to vary but little in the sections examined, though the apparent equivalent of the Coconino sandstone thins steadily.

Longwell's work⁵ in the Muddy Mountains of Nevada and the Virgin Mountains of Arizona

¹ Butler, B. S., and others, Ore deposits of Utah: U. S. Geol. Survey Prof. Paper 111, pp. 595-597, 1920.

² Longwell, C. R., Geology of the Muddy Mountains, Nev., with a section to the Grand Wash Cliffs in western Arizona: Am. Jour. Sci., 5th ser., vol. 1, p. 46, 1921.

³ Darton, N. H., A reconnaissance of parts of northwestern New Mexico and northern Arizona: U. S. Geol. Survey Bull. 435, pp. 25-27, 1910.

⁴ Noble, L. F., The Shinumo quadrangle, Grand Canyon district, Ariz.: U. S. Geol. Survey Bull. 549, p. 68, 1914.

⁵ Longwell, C. R., op. cit., p. 47.

shows that a change similar to that described above occurs westward from the typical area toward the Muddy Mountains. The Coconino sandstone thins and loses its identity, and the Supai formation changes largely from red to gray.

Nothing was observed to indicate an unconformity beneath or within the Supai formation, though continuous tracing might disclose it.

Schuchert⁶ in 1918 called attention to the thinning of the Coconino sandstone northward and northwestward from the typical area, suggesting, however, that the component sands came from that direction.

KAIBAB LIMESTONE.

The "Upper Aubrey" or "Aubrey limestone" of the older literature of southern Utah and northern Arizona was named the Kaibab limestone by Darton,⁷ the name Aubrey being retained in its broad sense, as a group term, to include the Supai formation, the Coconino sandstone, and the Kaibab limestone. In the Shinumo quadrangle, Ariz.⁸ (see map, fig. 10, No. 23), the Kaibab limestone is 520 feet thick and consists, in descending order, of a cherty gray limestone 75 feet thick, a white crystalline limestone 200 feet thick, a soft calcareous sandstone, locally a conglomerate of soft sandstone pebbles, 20 feet thick, a red and white calcareous sandstone 135 feet thick, a buff crystalline siliceous limestone 40 feet thick, and a calcareous white sandstone 50 feet thick. The 200-foot limestone and the 40-foot limestone form cliffs.

In most of the exposures seen in our work the Kaibab limestone shows a fivefold topographic and lithologic division—(1) a lower soft member consisting of gypsum, gray and yellow shale, soft gray sandstone, and subordinate amounts of thin-bedded dark-drab limestone; (2) a lower cliff-forming member of gray massive limestone with much brown to black concretionary chert; (3) an upper soft member with much the same character as the lower one; (4) an upper massive cliff-forming limestone which is similar to the lower one but contains more chert and which from Bright Angel Creek to southwestern Utah shows tower-like erosion forms along its upper cliff face; (5) a topmost member (Pl. IX, C), less resistant

than the underlying beds and highly variable in composition and thickness, consisting of shale, gypsum, and limestone. The limestone of the top member is at some places arenaceous, at others partly silicified, at still others filled with masses of light-colored chert that breaks into flat platy fragments; at many places the upper layers contain many small angular fragments of chert. In color it is light gray, yellowish brown, pink, and rarely a sugary white. The sandstone is gray to yellow, calcareous, and locally gypseous—that is, it has a gypsum cement. The shale may be gray, yellow, or rarely red. It is usually gypseous and in some places sandy.

These divisions of the Kaibab limestone vary much in thickness from point to point, and it seems unlikely that exactly the same beds enter into the same divisions at all localities. However, over as long a stretch as that along the Hurricane fault scarp from a point some distance south of Black Rock Canyon to Virgin Canyon—a distance of 25 miles—the lower four divisions are continuously exposed, though varying in thickness from place to place. The uppermost division is present locally but at a distance can not be distinguished from the overlying basal Moenkopi beds.

The lowest division is thin or lacking at several localities but is usually from 75 to 100 feet thick. The lower cliff-forming division ranges from 150 to 230 feet in thickness in the sections examined. The upper slope-forming division ranges from 80 to 285 feet in thickness. The upper cliff-forming division is variable, ranging from 185 to 455 feet. A thick limestone breccia occurs in the lower part of this unit in Virgin Narrows, below St. George (section 19, p. 75).

The uppermost member is composed of peculiar and characteristic rocks. It may be recognized, in spite of its variability, wherever it occurs, and as it is a definite unit between the upper cliff-forming limestone of the Kaibab and the basal beds of the Moenkopi formation it is here named the Harrisburg gypsiferous member, from its occurrence in the Harrisburg dome, 8 miles east of St. George. A section measured here (section 14, p. 73) shows a thickness of 280 feet. This member may be absent from some of the sections examined, but in others it reaches a thickness of nearly 300 feet. It is apparently the same unit as that designated "Super-Aubrey beds" by Huntington and Goldthwait.⁹ The uppermost limestone

⁶ Schuchert, Charles, On the Carboniferous of the Grand Canyon of Arizona: *Am. Jour. Sci.*, 4th ser., vol. 45, pp. 347-369, 1918.

⁷ Darton, N. H., A reconnaissance of parts of northwestern New Mexico and northern Arizona: *U. S. Geol. Survey Bull.* 435, p. 28, 1910.

⁸ Noble, L. F., The Shinumo quadrangle, Grand Canyon district, Ariz.: *U. S. Geol. Survey Bull.* 549, p. 70, 1914.

⁹ Huntington, Ellsworth, and Goldthwait, J. W., The Hurricane fault in the Toquerville district, Utah: *Harvard Coll. Mus. Comp. Zool. Bull.*, vol. 42, p. 203, 1904.



1. COCONINO SANDSTONE AND KAIBAB LIMESTONE IN HURRICANE FAULT SCARP, 6 MILES SOUTH OF HURRICANE, UTAH

The Supai formation may be represented at the base

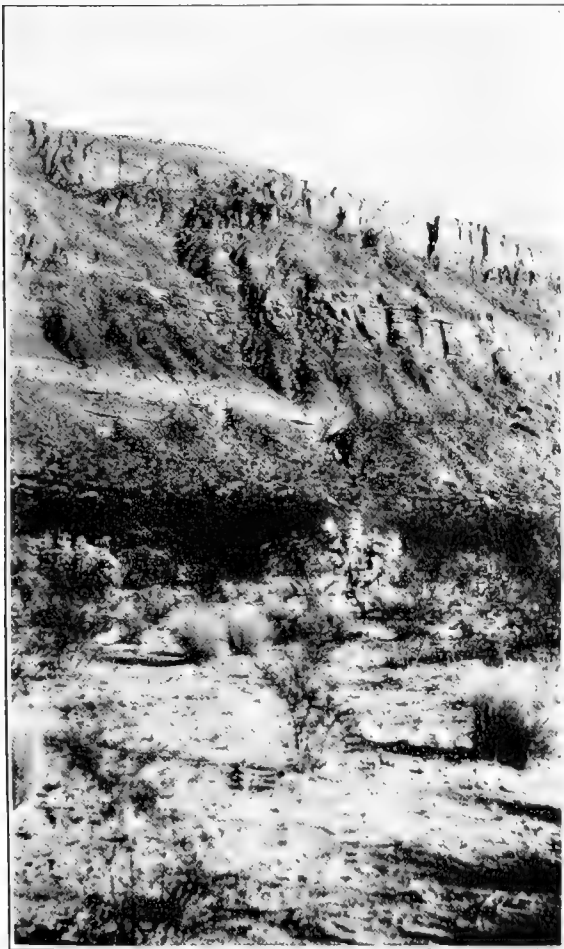

B. CLOSER VIEW OF MIDDLE PART OF SCARP SHOWN IN 1.



C. UPPER PART OF KAIBAB LIMESTONE AND BASAL MEMBER (ROCK CANYON) OF MOENKOPI FORMATION IN VIRGIN CANYON, 1½ MILES WEST OF VIRGIN CITY, UTAH.



A. VIEW NORTHWARD TOWARD SMITH'S MESA FROM A POINT JUST SOUTH OF VIRGIN CITY, UTAH.

Benches in foreground are the Virgin limestone member of the Moenkopi formation. Cliffs in background are the Moenkopi formation capped by the Shinarump conglomerate and supporting an outlier of the Chinle formation. The white Shaabkaib shale member of the Moenkopi forms a conspicuous band.

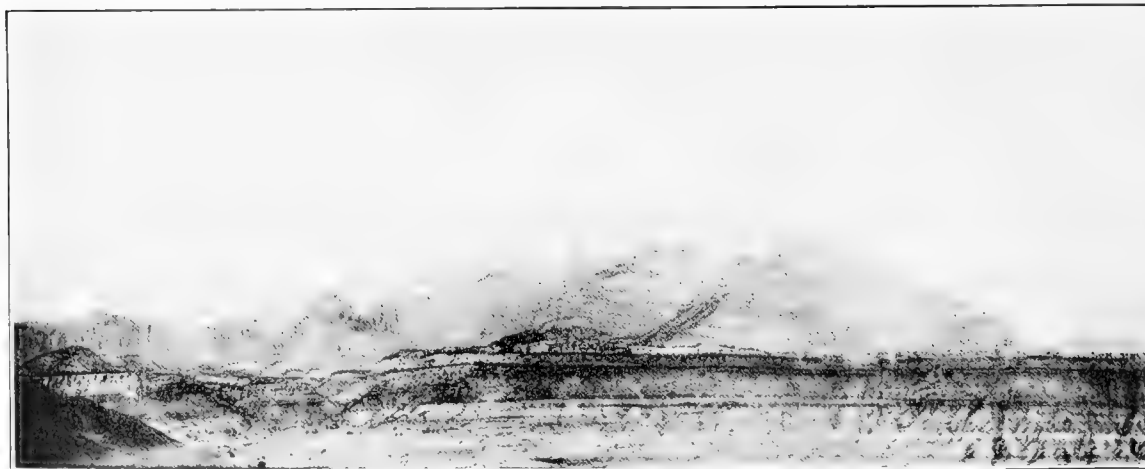

B. PANORAMA ALONG EAST SIDE OF COALPITS WASH, NEAR GRAFTON, UTAH.

The Shaabkaib member of the Moenkopi formation forms the foreground, with the upper dark-red member of the Moenkopi and the Shinarump conglomerate above it. This is followed by the Chinle formation and the massive red and white Jurassic sandstone, which forms the West Temple of the Virgin (Steamboat Mountain) in the background.

beds locally contain an abundance of a species of *Bellerophon* and are the "*Bellerophon* limestone" of some of the earlier geologists.

The Kaibab limestone of our area, as is shown in the data here presented, differs from that of the typical area in the absence of definite large sandstone units. This difference is apparent even in Hacks Canyon and Toroweap Valley. The upper cherty limestone of the Shinumo section (see p. 58) is comparable to our Harrisburg gypsiferous member, the 200-foot limestone to our upper cliff-forming member, the next lower 155 feet to our upper slope-forming member, the next lower 400 feet to our lower cliff-forming member, and the thin lower sandstone to our lower slope-forming member.

Longwell¹⁰ found in the Muddy Mountains of Nevada that the Kaibab limestone contained four divisions much like our four lowest members described above. The Harrisburg gypsiferous member, if present, is placed in his Moenkopi formation. The thickness ranges from 400 to 700 feet.

In tabular form the thickness of the several units in our sections may be stated thus:

Thickness of members of the Kaibab limestone, in feet.

Section. ^a	Harrisburg gypsiferous member.	Upper limestone member.	Upper slope-forming member.	Lower limestone member.	Lower slope-forming member.	Total Kaibab limestone.
1.....	190	315	125	180	20	830
2.....	190	185	175	225	(?)	775
4.....			225	195	147	
5.....	160	40+				
6.....	0?	400				
7.....	0?	400	225	215	108	948
8.....	160?	260	200	230	80	930
9.....	150	280	100	200+		
10.....	0?					
11.....	0?					
14.....	280 ±	(?)	(?)	(?)	(?)	1,059
15.....	0?					
16.....	272	115+				
17.....	259?	315	285	150+		
18.....	110	250+				
19.....	137	455	80	220	65	957
20.....	184?	195	260	170	115	924
23.....	75	200	155	40	20	490

^a Numbers refer to detailed sections given on pp. 69-77, except No. 23, which is the section in the typical area in the Shinumo quadrangle, and to localities shown on the map (fig. 10).

¹⁰ Longwell, C. R., Geology of the Muddy Mountains, Nev., with a section to the Grand Wash Cliffs in western Arizona; Am. Jour. Sci. 5th ser., vol. 1, p. 48, 1921.

MOENKOPI FORMATION.

The name Moenkopi formation was applied by Ward¹¹ to the beds known in the older literature as the lower division of the "Shinarump group," bounded below by Carboniferous limestone and above by the Shinarump conglomerate. A generalized section compiled by Gregory¹² from Ward's descriptions gives a thickness of about 700 feet, composed of saliferous and gypsiferous chocolate-brown shale and sandstone in the upper 500 feet, underlain by 100 feet of white calcareous shales, underlain in turn by 100 feet of brown shale. Ward mentions a discontinuous bed of white impure limestone in the calcareous unit. Gregory gives also an accurate section to serve as a type section, measured on Little Colorado River 5 miles below Tanner's Crossing and showing a thickness of 389 feet, mainly red and brown gypsiferous shale and sandstone, with unconformities at the top and bottom. Some conglomerate also is present. In eastern Arizona Gregory found a massive sandstone formation, the De Chelly sandstone, appearing between the ordinary Moenkopi red beds and the Shinarump conglomerate.

Shimer¹³ traced the Moenkopi formation from the type locality to Hurricane, Utah, and found it, though variable in composition, to extend over the entire area as a series of "thin-bedded red shales and sandstones, separated at usually rare intervals by limestone lenses."

In the area reconnoitered by us the beds that lie between the Carboniferous limestone and the Shinarump conglomerate and are referred to the Moenkopi formation are much thicker than at the typical locality. They may be grouped into five persistent lithologic units, with another discontinuous one at the base of the formation. The persistent units are (1) lower red beds, consisting of red to brown shale and sandstone with soft tan sandstone near the base and gypsum throughout in layers, streaks, and veinlets; (2) a limestone member consisting normally of three layers of yellow earthy limestone separated by yellow and red calcareous shale and carrying abundant

¹¹ Ward, L. F., Status of the Mesozoic floras of the United States. U. S. Geol. Survey Mon. 48, pt. 1, pp. 18-19, 1905.

¹² Gregory, H. E., Geology of the Navajo country; U. S. Geol. Survey Prof. Paper 93, p. 23, 1917.

¹³ Shimer, H. W., Permian-Triassic of northwestern Arizona; Geol. Soc. America Bull., vol. 30, pp. 493-494, 1919.

marine fossils, chiefly pelecypods; (3) middle red beds, much like the lowest unit but purer red in color; (4) gray to white sandy shale and soft sandstone, with some pink layers and much gypsum, presenting a marked banded unit in cliff faces; (5) upper red beds, consisting of brick-red to deep-red and brown shale and sandstone, color in upper part very dark, locally containing massive beds of yellow medium-grained sandstone. The writers propose the name Virgin limestone member for the second unit above the basal conglomerate member of the formation, from Virgin City, where the unit is splendidly exposed. For the white banded sandy shale unit the name Shnabkaib shale member is proposed, from the striking isolated mesa which lies 2 miles southwest of the town of Washington, on the northwest flank of the Washington dome, and which is still known by its old Indian name.¹⁴ (See Pl. X.) Section 13 (p. 73), measured near Virgin City, and section 14 (p. 73), measured 2 miles east of Shnabkaib, show the thickness and relation of these units to the whole formation.

The basal discontinuous unit is an exceedingly variable assemblage of shale, limestone, gypsum, conglomerate, and a minor amount of sandstone. To this unit we have given the name Rock Canyon conglomeratic member, from Rock Canyon, 5 miles north of Antelope Spring, Ariz. A detailed section at this locality is given on page 70 (section 6). The limestone is gray to pink, is usually coarse, and contains chert fragments. The shale may be gray, yellow, or red. The conglomerate is made up of limestone and chert boulders, locally as much as 3 feet in diameter but usually less than a foot, in a limestone cement and occurs in very irregular beds, which may lie at any stratigraphic level in the basal unit. Locally the included limestone fragments are angular and the material is really a breccia, though at most points observed they are rounded or only sub-angular. Locally this basal member is absent, as the sections show, and the lower red beds rest directly on limestones containing Kaibab fossils. At the head of Rock Canyon a great gash 700 feet wide and 250 feet deep has been cut into the Kaibab and filled with a confused mass of limestone, shale, gypsum, and conglom-

erate. This mass contains thin veins of asphaltite and zones impregnated with asphaltic material.

Lee¹⁵ found near Cedar City conglomeratic beds 175 feet thick resting unconformably on hard cherty Kaibab limestone and overlain by red shales. About 50 miles farther north, in Beaver Canyon, limestones and shales containing the Virgin limestone fauna rest on a thin conglomerate, and this in turn rests on cherty fossiliferous Kaibab limestone. Longwell¹⁶ found in the Muddy Mountains of Nevada depressions in the top of the Kaibab limestone filled with chert and limestone fragments. These fragmental deposits are the base of the Moenkopi formation.

Two complete sections were measured through the Moenkopi formation. Section 13 (p. 73), measured near Virgin City, shows a total thickness of 1,775 feet, of which 170 feet is the Rock Canyon conglomeratic member, 360 feet the lower red beds, 80 feet the Virgin limestone member, 400 feet the middle red beds, 360 feet the Shnabkaib shale member, and 405 feet the upper red beds. The other complete section (No. 14, p. 73) was measured on the south side of the Harrisburg dome, 8 miles west of Virgin City. Here the total thickness is 2,035 feet, of which 335 feet is assigned to the lower red beds, 160 feet to the Virgin limestone member, 435 feet to the middle red beds, 630 feet to the Shnabkaib shale member, and 475 feet to the upper red beds. The Rock Canyon conglomeratic member seems to be lacking at the Harrisburg dome.

Sections of parts of the formation were measured at several localities. In the Washington dome, just west of the Harrisburg dome (section 15, p. 74), the Rock Canyon conglomeratic unit is 288 feet thick, and the lower red beds are 320 feet thick. In the Bloomington dome (section 16, p. 74), south of St. George, the lower red beds are about 320 feet thick. Near Black Rock Spring (section 18, p. 75) the lower red beds are 180 feet thick. Near Bullrush, 12½ miles southwest of Freedomia, Ariz. (section 3, p. 70), the Virgin limestone member seems to be represented by a calcareous unit 11 feet thick. Farther west, in the neighborhood of Antelope Spring, it

¹⁴ Shnabkaib is said by Dr. J. P. Harrington, of the Bureau of American Ethnology, to be most probably a corruption of shōna'agaiv, from shōna'a, coyote, and gaiv or kaib, rocky hill, or mountain.

¹⁵ Lee, W. T., The Iron County coal field, Utah: U. S. Geol. Survey Bull. 316, p. 362, 1907.

¹⁶ Longwell, C. R., op. cit., p. 49.

forms a conspicuous member of the Moenkopi formation, perhaps 75 feet thick, and may be traced as a series of three marked benches near the base of the red cliffs of softer rock which stand high above the Hurricane fault scarp. West of this fault the Virgin limestone is conspicuous in every exposure of the lower part of the Moenkopi formation. In the Washington dome it is 160 feet thick and locally shows four limestone beds instead of the usual three beds. In the Bloomington dome it is 130 feet thick. Near Black Rock Spring it is 100 feet thick. The Shnabkaib shale member is a marked unit in the upper part of the Moenkopi formation at least as far east as a locality 8 or 10 miles east of Fredonia, Ariz. The Virgin limestone member was not observed here and may be entirely absent. The calcareous unit of Ward's typical section farther east may represent the extension of the Virgin limestone.

The sandstones in the upper red beds are not very conspicuous near Virgin City, but they are present along the Virgin anticline and northwest of St. George; along the Arrowhead Trail to Los Angeles they make up a considerable part of the upper red-bed unit. Though they nowhere stand up in massive cliffs they suggest in their position the De Chelly sandstone of Gregory; which occurs in eastern Arizona between the usual red beds of the Moenkopi formation and the Shinarump conglomerate.

The red sandstones of the Moenkopi are spotted locally with green copper stains that have caused much fruitless prospecting. The upper limestone of the Virgin limestone member at many places contains disseminated lead, zinc, and copper sulphides in small amount.

Huntington and Goldthwait¹⁷ give a section of the Moenkopi formation near Toquerville, about halfway between our two complete sections, in which our units are recognizable but the thicknesses are very different. This section shows, at the base, soft red shales, 170 feet; gray and red shales with three limestone benches, 115 feet; soft red shales, with some harder gray layers, 250 feet; white and red shales, 390 feet; chocolate-colored, gray, and

lavender shale and sandstone, 380 feet; total, 1,205 feet. There is no apparent thinning westward from Virgin City to Toquerville, but rather the reverse, and we question the accuracy of this section.

Near Cedar City, Utah, Lee¹⁸ measured sections which show a total thickness of 2,650 feet for the beds here called the Moenkopi formation. They contain a fossiliferous limestone member equivalent to the Virgin limestone member. About 50 miles farther north Lee found the Virgin limestone fauna to persist through a thickness of 350 feet of shale and limestone, overlain by unfossiliferous limestones making a total of at least 600 feet of strata with limestone beds above the fossiliferous Kaibab limestone.

Longwell¹⁹ found that in the Muddy Mountains of Nevada the Moenkopi formation consists of thin-bedded limestones, shale, and sandstone. The thickness ranges from 1,200 to 1,600 feet, of which the lower half is predominantly marine limestone and the upper half continental deposits.

Apparently the red beds of the typical Moenkopi formation pass westward and north-westward into marine limestones. The thin limestone of the typical area is the edge of a wedge which increases to the Virgin limestone member and then to the thicker limestone members found by Lee and Longwell.

Walcott²⁰ found in Kanab Valley a limestone and shale unit like our lower Moenkopi beds, 198 feet thick, overlain by a shale and sandstone unit 666 feet thick. These beds lie between the "*Bellerophon* limestone" of the Kaibab formation and the Shinarump conglomerate. The limestone in the lower division carries Walcott's "Permian" fauna, now known to be Lower Triassic.

The Moenkopi formation is unconformable on the Kaibab limestone. The basal conglomeratic member of the Moenkopi, the variation in the thickness of the Harrisburg member of the Kaibab limestone, and the presence of a gash cut deep into the massive Kaibab and filled with Moenkopi materials near the head of Rock Canyon show an erosion interval. Evidence of an erosional interval at this horizon

¹⁸ Lee, W. T., The Iron County coal field, Utah: U. S. Geol. Survey Bull. 316, p. 362, 1907.

¹⁹ Longwell, C. R., op. cit., p. 49.

²⁰ Walcott, C. D., The Permian and other Paleozoic groups of the Kanab Valley, Ariz.: Am. Jour. Sci., 3d ser., vol. 20, pp. 221-225, 1890

¹⁷ Huntington, Ellsworth, and Goldthwait, J. W., The Hurricane fault in the Toquerville district, Utah: Harvard Coll. Mus. Comp. Zool. Bull., vol. 42, p. 203, 1904.

has been noted by a number of observers. Powell,²¹ Walcott,²² Dake,²³ Lee,²⁴ Gregory,²⁵ Shimer,²⁶ and Longwell²⁷ have all cited evidence of its presence over a wide area and of its considerable magnitude.

SHINARUMP CONGLOMERATE.

The Shinarump conglomerate forms a marked stratum throughout northern Arizona and southern Utah. It is thin but resistant and in many places caps mesas or forms prominent benches. (See Pl. X.)

The name was originally given by Powell²⁸ to the middle member of his "Shinarump group."

In our area only one detailed section was made, that north of Virgin City (section 13, p. 73), where the Shinarump conglomerate was found to consist of three members—(1) at the base a brown sandstone 75 feet thick, with lines and lenses of pebbles of chert, quartz, silicified wood, and rarely of igneous rock and with fossil logs; (2) gray and green shale with some fossil wood, 20 feet thick; and (3) at the top gray platy sandstone with a few pebbles, 20 feet thick. The base of the lower sandstone is irregular and is marked by a discontinuous layer of dark shale. This plane is an evident disconformity, but of what significance it is difficult to say. At the Harrisburg dome (section 14, p. 73) the Shinarump conglomerate is about 100 feet thick and consists of sandstone. It seems to be fairly uniform over most of the area examined, but 15 miles northwest of St. George it is less than 50 feet thick and not as resistant as usual. To the east, on the Kanab-Fredonia road, the conglomerate is 40 feet thick.

The Shinarump locally contains crusts of iron and manganese oxides which are high in

manganese but do not occur in sufficient amount to have a commercial value. The fossil logs are locally replaced in part by copper sulphides instead of silica.

CHINLE FORMATION.

The name Chinle formation was given by Gregory²⁹ to the beds above the Shinarump conglomerate and below the Wingate sandstone. Gregory was able to distinguish four persistent divisions, which are, in ascending order, (1) dark-red, light-red, chocolate-colored, or rarely gray shales (70 per cent) and shaly sandstone (30 per cent), with brown conglomerate of limestone and clay pebbles; (2) shales and "marls" with rare calcareous sandstone, all lenticular, exceedingly friable, red, ash-colored, and purple, with characteristic limestone conglomerate; (3) gray, pink, and purple cherty limestone and light to dark red shale in alternating bands; (4) red, brown, pink, or rarely gray calcareous shales and shaly sandstones, with a few thin bands of limestone and limestone conglomerate. In a composite section given by Gregory division 1 is 203 feet thick; 2, 450 feet; 3, 214 feet; and 4, 315 feet.

In our area only one section of the Chinle formation was measured, though the formation is a prominent member of the stratigraphic series. (See Pl. XI, A.) This section (No. 13, p. 73) is near Virgin City and aggregates 995 feet in thickness. No limestones were observed. The basal member consists of 260⁴ feet of variegated, bluish-gray, greenish-gray, mauve, red, and rarely brown "gumbo" clay shale and contains fossil wood. Upon this rests 25 feet of variable coarse arkosic cross-bedded sandstone banded with gray, white, and mauve and containing fossil wood. This sandstone is overlain by 420 feet of brick-red shale and sandstone, forming a slope. Next comes a massive medium-grained cross-bedded ripple-marked cliff-forming mauve sandstone 90 feet thick. Above this sandstone lies about 200 feet of brick-red to deep-red shale and sandstone.

The banded gray, white, and mauve sandstone is locally known as the "Silver Reef sandstone," as it is said to be the zone which in the Silver Reef, near Leeds, Utah, contains the fossil logs impregnated with silver minerals

²¹ Powell, J. W., Report on the geology of the eastern portion of the Uinta Mountains, U. S. Geol. and Geol. Survey Terr., 2d div., 1876.

²² Walcott, C. D., The Permian and other Paleozoic groups of the Kanab Valley, Ariz.: Am. Jour. Sci., 3d ser., vol. 20, pp. 221-225, 1880.

²³ Dake, C. L., The pre-Moenkopi (pre-Permian?) unconformity of the Colorado Plateau: Jour. Geology, vol. 28, pp. 61-74, 1920.

²⁴ Lee, W. T., General stratigraphic break between Pennsylvanian and Permian in western America [abstract]: Geol. Soc. America Bull., vol. 28, pp. 169-170, 1917.

²⁵ Gregory, H. E., Geology of the Navajo country: U. S. Geol. Survey Prof. Paper 93, p. 30, 1917.

²⁶ Shimer, H. W., Permian-Triassic of northwestern Arizona: Geol. Soc. America Bull., vol. 30, p. 494, 1919.

²⁷ Longwell, C. R., Geology of the Muddy Mountains, Nev., with a section to the Grand Wash Cliffs in western Arizona: Am. Jour. Sci., 5th ser., vol. 1, p. 49, 1921.

²⁸ Powell, J. W., Report on the geology of the eastern portion of the Uinta Mountains, pp. 53, 68-69, U. S. Geol. and Geol. Survey Terr., 2d div., 1876.

²⁹ Gregory, H. E., Geology of the Navajo country: U. S. Geol. Survey Prof. Paper 93, pp. 42-43, 1917.



A. CHINLE FORMATION AND OVERLYING MASSIVE JURASSIC SANDSTONE IN ZION CANYON ABOVE SPRINGDALE, UTAH.



B. CROSS-BEDDING IN WHITE UPPER PART OF MASSIVE JURASSIC SANDSTONE 12 MILES NORTH OF ST. GEORGE, UTAH, ON ST. GEORGE-MODENA ROAD.

that in the eighties supported several flourishing mining enterprises.³⁰

The mauve cliff-forming sandstone is the "mauve sandstone" of Huntington and Goldthwait.³¹ These authors give the thickness of the Chinle (their "Painted Desert formation") near Toquerville as only 350 feet, though they seem not to have included the beds above the mauve sandstone. Lee³² observed at a locality near Cedar City, Utah, 520 feet of red shale and sandstone resting upon the Shinarump conglomerate, overlain by 250 feet of massive cross-bedded sandstone, and that in turn by 180 feet of sandstone and red, purple, and gray shale, a total of 950 feet. In a later report³³ Lee placed only the lower 520 feet of this series in the Chinle formation, but the entire 950 feet evidently corresponds to our Chinle formation, which is included between the massive sandstone described below, whose basal part, at least, is probably equivalent to the Wingate sandstone, and the Shinarump conglomerate. Longwell³⁴ refers to the Chinle formation in Nevada as a variable assemblage of conglomeratic sandstone, finer sandstone, and gypsiferous shale. Its thickness ranges from 800 to 3,000 feet.

Walcott found in Kanab Valley a fossiliferous zone³⁵ about 900 feet above the Shinarump conglomerate, which seems from the description to be near the top of the Chinle formation, though possibly it is in the base of the overlying sandstone, which is not as massive as it is farther west. The fossils were fish and reptilian teeth, *Estheria*, and a fragment of an ammonite and are said to suggest Jurassic rather than Triassic relationship.

JURASSIC SANDSTONE.

Gregory³⁶ assigned three formations in eastern Arizona and western New Mexico to the La Plata group—the Wingate sandstone below,

the Todilto formation in the middle, and the Navajo sandstone above. The Wingate sandstone is a massive cross-bedded fine-grained cliff-forming dark-red to light-red or orange-red sandstone, in which the cross-bedding is largely tangential and gives rise on weathering to characteristic arches and caves; its thickness ranges from 200 to 500 feet. The Todilto is a very thin formation of calcareous sandstone and limestone, barren of fossils. The Navajo sandstone is tangentially cross-bedded massive yellow to red sandstone with a few thin layers of blue limestone. It is resistant and cliff-forming and usually weathers into domes and rounded forms at the top; its thickness ranges from 100 to more than 1,000 feet. The whole group ranges from perhaps 400 feet to well over 1,000 feet in thickness.

In Washington County, Utah, there lies above the Chinle formation a massive cross-bedded sandstone that is locally all red but in most places red in the lower part and white above, the red portion making up one-half or more of the unit. The lower part characteristically forms arches, and the upper part weathers to rounded pinnacles and domes. (See Pl. XI, A, B.) Upon this white sandstone rests a series of brick-red sandstone and shale perhaps 200 feet thick. This unit is soft and is conspicuous only where it is left as erosional remnants on the white sandstone. It seems to belong rather to the succeeding unit than to the sandstone. Only one measurement of the thickness of the sandstone was attempted, and that with rather unsatisfactory results. This measurement was made by triangulation from Coalpits Wash, just west of Zion Canyon, on the west side of the West Temple of the Virgin, or, as it is locally known, Steamboat Mountain, and gave a total thickness of 2,100 feet, mostly in sheer wall. There appears here to be no break of any kind in the sandstone wall; not even a single soft layer is observable. Farther east, toward Kanab, Utah, the sandstone is less massive and contains softer layers. To the west, near St. George, Utah, the same is true; in fact there appear to be many softer layers, and the sandstone forms a number of benches. Northwest of St. George, in the valley of Santa Clara Creek, the unit again takes on a massive cliff-forming character and stands in high, sheer walls with the top weathered into rounded

³⁰ Butler, B. S., and others, Ore deposits of Utah: U. S. Geol. Survey Prof. Paper 111, pp. 582-594, 1920.

³¹ Huntington, Ellsworth, and Goldthwait, J. W., The Hurricane fault in the Toquerville district, Utah: Harvard Coll. Mus. Comp. Zool. Bull., vol. 42, p. 203, 1904.

³² Lee, W. T., The Iron County coal field, Utah: U. S. Geol. Survey Bull. 316, p. 362, 1907.

³³ Lee, W. T., Early Mesozoic physiography of the southern Rocky Mountains: Smithsonian Misc. Coll., vol. 60, No. 4, p. 22, 1918.

³⁴ Longwell, C. R., op. cit., p. 51.

³⁵ Discussed in Cross, Whitman, and Howe, Ernest, Red Beds of southwestern Colorado and their correlation: Geol. Soc. America Bull., vol. 16, pp. 486-487, 1905.

³⁶ Gregory, H. E., Geology of the Navajo country: U. S. Geol. Survey Prof. Paper 93 p. 52, 1917.

forms. Here the tangential cross-bedding of the upper white part is a striking feature and resembles that of the Navajo sandstone farther east. The thickness is comparable with that at Zion Canyon.

The white upper part of the sandstone seems to be the White Cliff sandstone, and the red lower part the Vermilion Cliff sandstone of Dutton and other earlier students of the geology of the region. Huntington and Goldthwait³⁷ called the red part the "Kanab sandstone" and the white part the "Colob sandstone." As the color boundary within a short distance may vary from the middle to the top of the Jurassic sandstone, units based on color alone are hardly tenable in this area.

Lee³⁸ found on Coal Creek, near Cedar City, two massive sandstones separated by a softer unit that aggregate 1,700 feet in thickness and seem to represent our sandstone unit. Lee³⁴ later included about 400 feet more of lower beds with these, but the character of the lower beds fits the Chinle formation better, and they should perhaps be assigned to that formation. Lee considered the whole thickness of 2,100 feet to be the equivalent of the Wingate sandstone.

Longwell⁴⁰ found in the Muddy Mountains of Nevada a cross-bedded sandstone ranging from 800 to 2,000 feet in thickness, resting upon the Chinle formation. He correlated this unit with the La Plata group.

Whether this Jurassic sandstone of southwestern Utah and adjacent regions represents the entire La Plata group of Gregory may be questioned. It seems to be identical with Emery's Wingate sandstone⁴¹ of the San Rafael Swell region and with the Wingate of Lee's Coal Creek section. Dake⁴² believes that it represents the entire La Plata group of Gregory, not merely the typical Wingate, and disputes the interpretation of Emery and Lee.

The Wingate is reported to be unconformable on the Chinle formation at some places. We saw no evidence of this unconformity in

the area covered by our work, though close examination was not made at many points.

JURASSIC LIMESTONE AND SHALE.

Resting on the thick Jurassic sandstone just discussed lies a series of beds which consist of red shale and sandstone, with some gypsum, in the lower part and greenish-gray, cream-colored, and brown marine fossiliferous limestone in the upper part. The only section of these beds obtained was measured on the east side of Diamond Valley, 15 miles north of St. George, Utah (section 21, p. 77). Here the red shales and sandstone form the floor of the valley between the sandstone and the limestone and are but poorly exposed. Their total thickness is about 160 feet. The patch of red rock on the top of the West Temple of the Virgin (Steamboat Mountain) seems to include this interval but is a little thicker than the beds in Diamond Valley. Above the red shales at Diamond Valley is 300 feet of limestone with some shale and gypsum layers, much of it cream-colored, but some layers, especially in the upper part, brownish, gray, and greenish white. Fossils were observed in a number of layers but were so poorly preserved as not to be worth collecting. However, abundant *Pentacrinus* stem joints, *Trigonia* sp. like *T. americana*, and a small *Ostrea* were recognizable and fix the age as undoubtedly that of the marine Jurassic of the region.

Lee⁴³ measured near Cedar City 40 feet of red shale and gypsum resting on the massive Jurassic sandstone, then 250 feet of brown earthy limestone which seems to correspond to our beds. Stanton⁴⁴ measured near Glendale a section with 8 feet of red shale near the base, overlain by 292 feet of fossiliferous limestone and shale. Dake⁴⁵ found near Teasdale 449 feet of gypsiferous limestone and shale above his La Plata group.

We saw no evidence of unconformity in this series, but close examination was made at only one locality.

CRETACEOUS (?) VARIEGATED SHALE.

Above the marine Jurassic limestone occurs a bluish-gray, red, and greenish-gray "gumbo"

³⁷ Huntington, Ellsworth, and Goldthwait, J. W., The Hurricane fault in the Toiyaville district, Utah: Harvard Coll. Mus. Comp. Zool. Bull., vol. 42, p. 233, 1904.

³⁸ Lee, W. T., The Iron County coal field, Utah: U. S. Geol. Survey Bull. 316, p. 362, 1907.

³⁹ Lee, W. T., Early Mesozoic physiography of the southern Rocky Mountains: Smithsonian Misc. Coll., vol. 60, No. 4, p. 22, 1918.

⁴⁰ Longwell, C. R., op. cit., p. 51.

⁴¹ Emery, W. B., Green River Desert section: Am. Jour. Sci., 4th ser., vol. 16, pp. 551-577, 1918.

⁴² Dake, C. L., The horizon of the marine Jurassic of Utah: Jour. Geology, vol. 27, pp. 634-646, 1919 [1920].

Lee, W. T., The Iron County coal field, Utah: U. S. Geol. Survey Bull. 316, p. 362, 1907.

⁴⁴ Stanton, T. W., unpublished notes.

⁴⁵ Dake, C. L., The horizon of the marine Jurassic of Utah: Jour. Geology, vol. 27, pp. 634-646, 1919 [1920].

shale, with a little thin limestone in the upper part and some platy sandstone in the lower part. At Diamond Valley (section 21, p. 77) it is 140 feet thick. We can not say from the data obtained in the small area examined closely whether this unit is conformable or unconformable on the underlying beds.

Lee⁴⁶ noted near Cedar City a similar unit 350 feet thick; Stanton,⁴⁷ near Glendale, Utah, the same, 550 feet or more; and Dake,⁴⁸ near Teasdale, the same, over 375 feet.

CRETACEOUS (?) SANDSTONE.

Resting upon the variegated shale just described is a series of buff sandstones with some intercalated shale. These are visible at many places along the lower flanks of the Pine Valley Mountains, north of the region covered by our work. A section of these sandstones was made at Diamond Valley. The lower 90 feet of this series is light-gray to brown sandstone, mostly soft but with some hard layers and a little gray and purple shale. This sandstone shows stem imprints and carbonaceous matter. Above it is a thin layer of very dense reddish and blue-gray quartzite, and upon this 30 feet of gray shale and carbonaceous sandstone. Above this lower part comes 750 feet, more or less, of heavy-bedded buff sandstone, of which the lower 300 feet has soft sandstone layers and shale between the harder sandstones, but the upper 450 feet is buff sandstone with one reddish layer. Above the rocks just described, at the point of measurement, wash and basaltic lava conceal the bedrock. No fossils were observed other than the impressions of plant stems mentioned.

Lee⁴⁹ found on Coal Creek, near Cedar City, above the shale which rests upon the marine Jurassic limestone an unconformity marked by a conglomerate, followed by 780 feet of variegated shale and gray or light-colored sandstone, upon which rests 125 feet of gray and yellow sandstone, with coal and minor shale layers and carrying Cretaceous fossils. Above these coal-bearing beds in Lee's section is exposed 455 feet of sandstone with a minor amount of shale and limestone and carrying marine

Cretaceous fossils. Richardson⁵⁰ found in the Colob coal field, not far from the areas examined by Lee, 2,500 feet of buff sandstone and drab shale, with coal in the lower part, all of which he referred to the Colorado group. Beneath it he found 800 feet of varicolored shale and sandstone, gypsum, and marine limestone representing the Cretaceous (?) shale and Jurassic limestone of this paper. Richardson⁵¹ also found in the valley of Virgin River near Mount Carmel a series of beds including, in ascending order, 15 feet of conglomerate, 400 feet of coal-bearing shale and sandstone, 700 feet of shale with marine fossils, and 1,000 feet of alternating sandstone and shale containing marine and brackish-water Colorado fossils near the base. On these beds rests 10 feet of conglomerate, then 700 feet of fresh-water sandstone and shale possibly of Montana age, then another conglomerate, probably Tertiary. Stanton⁵² found near Glendale, 6 miles from Mount Carmel, 91 feet of coal-bearing gray sandstone and shale resting on the Cretaceous (?) variegated shale above the marine Jurassic. Upon this coal-bearing unit rests 1,000 feet, more or less, of drab sandy marine shale of Colorado age, and upon this, in the section examined, 280 feet of brown sandstone and shale with Colorado fossils.

TERTIARY (?) SANDSTONE.

Above the buff Cretaceous sandstone series is exposed in the flanks of the Pine Valley Mountains a pink sandstone series. At a point near Diamond Valley, 3 miles south of the locality where the buff sandstone was measured, an exposure of 1,500 feet of these pink sandstones was examined. It consists of massive sandstone beds, yellow with some red staining and separated by soft sandstone, much of it red in color, and red shale. As a mass this series is pink and contrasts sharply with the lower buff sandstone series. So far as could be determined by inspection from a high point several miles away, the base of this exposure is very close to the top of the Cretaceous (?) sandstone. Intervening outcrops piercing the wash and lava cover aid in judging this, though continuous tracing is impossible.

⁴⁶ Lee, W. T., The Iron County coal field, Utah: U. S. Geol. Survey Bull. 316, p. 362, 1907.

⁴⁷ Stanton, T. W., unpublished notes.

⁴⁸ Dake, C. L., op. cit.

⁴⁹ Lee, W. T., The Iron County coal field, Utah: U. S. Geol. Survey Bull. 316, p. 362, 1907.

⁵⁰ Richardson, G. B., The Harmony, Colob, and Kanab coal fields, southern Utah: U. S. Geol. Survey Bull. 311, p. 381, 1908.

⁵¹ Richardson, G. B., unpublished notes.

⁵² Stanton, T. W., unpublished notes.

TERTIARY (?) AND QUATERNARY ROCKS.

Basaltic flows, apparently of late date, in places little weathered and with only a thin soil cover, occupy considerable areas of the region. Associated with them are local thick boulder beds and here and there cinder cones. (See Pls. XII; XIII, B.) At some places large areas of dune sand occur, notably that 8 miles southeast of St. George. Along Virgin River alluvial flats supply land for irrigation farming.

AGE OF THE FORMATIONS.

The Redwall limestone at the locality of its typical occurrence is believed to be in part Mississippian and in part Pennsylvanian. In the Beaverdam Mountains we collected *Margifera* aff. *M. splendens* (catalog No. 3059) at a horizon 650 to 700 feet beneath the top of the formation, and *Chaetetes milleporaceus* (catalog No. 3061) at a horizon about 1,000 feet beneath the top. G. H. Girty reports both these species to indicate either Pennsylvanian or Permian age. It is therefore probable that at least 1,000 feet of the Redwall limestone, as here conceived, is Pennsylvanian.

The Supai formation, Coconino sandstone, and Kaibab limestone for years were considered to represent the Pennsylvanian. The evidence accumulated from many sources, however, is increasingly in favor of a correlation of all three formations with the Manzano group of New Mexico, now classified as Permian. In this paper the Supai formation and the Coconino sandstone are assigned doubtfully to the Pennsylvanian and the Permian, respectively, as the available evidence of their age is still insufficient to warrant a definite assignment. The Kaibab limestone is placed in the Permian, because it afforded a number of lots of fossils, and although no attempt was made to gather complete collections, those obtained permit correlation with part of the Manzano group. The following combined lists show the determinations made by Mr. Girty:

1. Five collections (catalog Nos. 3054 to 3058) from the "Bellerophon limestone" of the Harrisburg gypsiferous member:

Phyllopora? sp.
Dielasma sp.
Nucula levatiformis.
Leda obesa.
Pteria (Bakewellia?) sp.
Pseudomonotis? sp.
Myalina sp.

Schizodus wheeleri.
Aviculipecten? sp.
Pleurophorus mexicanus.
Plagioglypta canna.
Bellerophon majusculus.
Bucanopsis aff. *B. bella*.
Euphemus sp.
Pleurotomaria sp.
Goniospira sp.
Naticopsis? sp.
Platyceras sp.
Eumophalus sp.
Metacoceras sp.
Nautilus sp.

2. Five collections (catalog Nos. 3047 to 3051) from lower strata of the Harrisburg gypsiferous member:

Batostomella n. sp.
Polypora sp.
Phyllopora? sp.
Derbya? sp.
Chonetes hillanus.
Pugnax osagensis var.
Spirifer sp.
Spiriferina sp.
Squamularia guadalupensis.
Composita subtilita.
Composita n. sp.
Myalina aff. *M. deltoidea*.

3. A single lot (catalog No. 3060) from a coral-bearing limestone near the top of the Harrisburg gypsiferous member in the Harrisburg dome:

Favosites? n. sp.
Lithostrotion? n. sp.
Campophyllum? n. sp.

4. Eight collections (catalog Nos. 3039 to 3046) from the massive limestone members of the Kaibab limestone:

Sponge, undetermined.
Echinocrinus sp.
Spirorbis sp.
Batosomella n. sp.
Lioclema sp.
Fenestella sp.
Polypora sp.
Septopora n. sp.
Derbya aff. *D. nasuta*.
Orthotetes sp.
Meekella pyramidalis.
Chonetes hillanus.
Productus ivesi.
Productus occidentalis.
Productus popei.
Pustula subhorrida.
Pustula subhorrida var.
Pustula aff. *P. irginae*.
Margifera splendens?
Margifera? aff. *M. splendens*.
Dielasma sp.
Squamularia guadalupensis.
Spiriferina sp.
Composita mexicana?
Composita subtilita.
Pseudomonotis? sp.



A. GROUP OF CINDER CONES OF LATE DATE AND ASSOCIATED LAVA; DIAMOND VALLEY, 12 MILES NORTH OF ST. GEORGE, UTAH.



B. NEARER VIEW OF LARGER CONE OF GROUP SHOWN IN A.

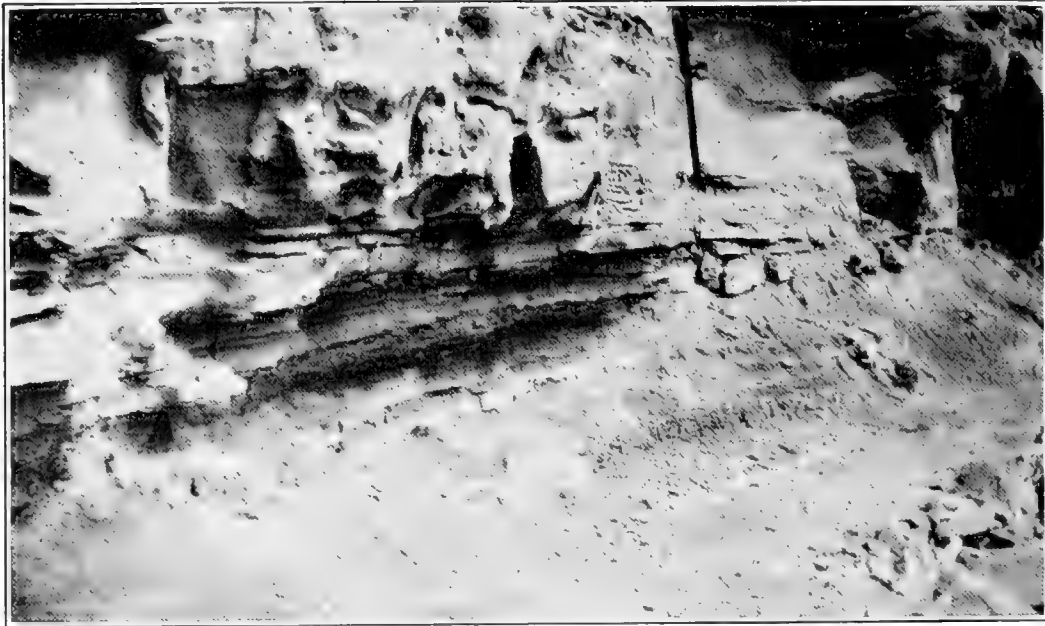

A. SHINARUMP CONGLOMERATE RESTING ON UPPER MOENKOPI SHALE AND SANDSTONE, SMITH'S MESA, 3 MILES NORTH OF VIRGIN CITY, UTAH.



B. LATE BASALT FLOW RESTING ON A CONGLOMERATE OF BASALT AND OTHER BOULDERS, ON ROAD FROM TOQUERVILLE TO LA VERKIN, UTAH.

Aviculipecten, 3 sp.
Acanthopecten coloradoensis.
Acanthopecten? sp.
Orthoceras sp.

Regarding these Kaibab fossils Mr. Girty says:

The fauna of the Kaibab limestone, which I regard as of Permian age, presents two fairly distinct facies corresponding to different stratigraphic horizons. The upper fauna consists largely of gastropods (especially *Bellerophon*) and pelecypods (especially *Leda*). This is clearly the horizon that was called the "*Bellerophon* limestone" by the geologists working along the Grand and Green rivers and was regarded by them as the top of the Carboniferous. (See list 1, above.)

What may be regarded as the normal Kaibab fauna, characterized by such species as *Productus ivesi*, *P. occidentalis*, *Pustula subhorrida*, and *Meckella pyramidalis*, is represented (in list 4 above). Those lots containing *Squamularia guadalupensis* in abundance accompanied by *Chonetes hillanus* form an appreciable subgroup in this fauna and perhaps represent a separate horizon. Essentially the same fauna occurs in the San Andres limestone of the Manzano group of New Mexico. (See list 2, above.)

The coral fauna (list 3, above) is unique. It is totally unlike any other fauna in the collection, and I do not recall ever having seen it before.

The Moenkopi formation was attributed by some earlier geologists to the Permian and by some to the Triassic. Later, largely on the basis of Walcott's work near Kanab, Utah, it was universally accepted as Permian, and this assignment received some confirmation from a few very poorly preserved plants that bear considerable resemblance to certain species of the well-known Permian genus *Walchia*.⁵³ The Moenkopi formation has been regarded generally as equivalent to the "Permo-Carboniferous" of the Wasatch Mountains. The latter beds have lately been proved equivalent to beds in Idaho⁵⁴ whose age is accepted universally as Lower Triassic. The Moenkopi formation must therefore be considered of Lower Triassic age. Mr. Girty's restudy of Walcott's original "Permian" fossils from the Moenkopi near Kanab, Utah, and the collections made during the present work lend strong support to this correlation. The fossils collected by us came from the Rock Canyon conglomeratic member, at the base of the entire Moenkopi red-bed series, and from the Virgin limestone member. The following combined lists show the species identified by Mr. Girty:

5. Single lot (catalog No. 7791) associated with oil-bearing layer at the oil seep 1½ miles west of Virgin City, near top of Rock Canyon conglomeratic member:

Bakewellia sp. (small form).
Myalina sp. (small form).
Myophoria? sp.
Pleurophorus sp.
Pseudomelania? sp.
 Ostracoda.

6. Single lot (catalog No. 7781) from a horizon 8 feet above that just listed but at same locality:

Bakewellia n. sp.
Pseudomonotis n. sp.
Pleurophorus sp.
Naticopsis sp.
Pseudomelania? sp.

7. Seven lots (catalog Nos. 7770 to 7775, 7780) from dark fetid limestones in thin sheets in gypsum beds; all from Rock Canyon conglomeratic member:

Bakewellia n. sp. (small form).
Myophoria sp.
 Goniatite or ammonite undetermined.
 Sponge spicules (amphioxes with a few triaenes).

8. Single lot (catalog No. 7788) from basal conglomerate bed in Rock Canyon conglomeratic member:

Monotis? sp.
Myalina n. sp.
Macrocheilina? sp.

9. Single lot (catalog No. 7794) from horizon 50 feet above base of Rock Canyon conglomeratic member:

Spirorbis sp.
Discina sp.
Terebratula sp.
Pseudomonotis n. sp.
Pleurophorus? (*Modiola?*) n. sp.
Pseudomelania n. sp.

10. Single lot (catalog No. 7796) from a horizon near top of Rock Canyon conglomeratic member:

Pseudomonotis sp.
Myalina sp.
Entolium? sp.
Naticopsis n. sp.
Bulimorpha n. sp.
Pseudomelania?, several n. sp.
Turritella, several n. sp.
Meekoceras aff. *M. mushbachanum*.
 Numerous undetermined gastropods.

11. Nine lots (catalog Nos. 7782 to 7787, 7790 to 7792) from the Virgin limestone member:

Isocrinus sp.
Spirorbis sp.
Pugnax n. sp.
Terebratula? n. sp.
Pinna? sp.
Bakewellia n. sp.
Pseudomonotis n. sp.
Monotis? sp.
Myalina n. sp.
Aviculipecten, 4 sp.
Myophoria? sp.

⁵³ Gregory, H. E., *Geology of the Navajo country*: U. S. Geol. Survey Prof. Paper 93, p. 31, 1917.

⁵⁴ Girty, G. H., in Butler, B. S., and others, *The ore deposits of Utah*: U. S. Geol. Survey Prof. Paper 111, p. 642, 1920.

Pleurophorus n. sp.
 Pleurotomaria, 2 sp.
 Naticopsis sp.
 Ammonite?

Concerning these Moenkopi fossils Mr. Girty says:

Lists 6, 8, and 11 show what I regard as the normal Moenkopi fauna.

Besides these I recognize another group (list 7) which presents a peculiar cherty lithology and a fauna composed chiefly of small species of *Bakewellia* and *Myophoria*. I do not feel sure that this group does not represent a condition rather than a geologic horizon.

List 5 may represent a distinct faunal facies, but I am inclined to believe that it belongs with list 7.

List 9 probably belongs with lists 6, 8, and 11, but it may represent a distinct subfauna.

List 10, with its innumerable gastropods, is unique in the collection, but the horizon is undoubtedly Moenkopi.

Regarding the Triassic age of the Moenkopi, from which I understand there has been obtained some very meager plant evidence having a Permian cast, I will say the following:

The age of these Moenkopi beds does not depend solely upon the fossils immediately contained in them but is bound up with the Lower Triassic fauna of Idaho. There is scarcely room for reasonable doubt that Walcott's "Permian" of the Kanab Canyon section, which is Moenkopi, is the same as the "Permo-Carboniferous" of the Wasatch Mountains, and that the "Permo-Carboniferous" of the Wasatch Mountains is the same as the well-known Lower Triassic of Idaho. This correlation is, I believe, in a general way beyond dispute. I am personally convinced of it from my own studies. If the Moenkopi is Permian, then, consequently, the Lower Triassic of Idaho is Permian. Now, I have not investigated the question myself, but there seems to be a general agreement as to the age of the beds in Idaho.

As regards the evidence furnished by the Moenkopi beds themselves, I have identified *Meckoceras*, one of the distinctive ammonites of the Idaho faunas, both in the present collections and in Mr. Walcott's, and there are a few other characteristic Triassic types, though less important ones. I may also point out that there is an almost complete faunal change from the Kaibab to the Moenkopi. Both faunas are fairly extensive, but I know of no species that they contain in common. Furthermore, all the characteristic Paleozoic genera of brachiopods become extinct with the Kaibab—*Productus*, *Chonetes*, *Derbya*, *Meckella*, *Spirifer*, *Composita*, and a score of others—not to mention the numerous bryozoan types—*Fenestella*, *Septopora*, *Rhombopora*, *Stenopora*, and many more. These types appear neither in the typical Moenkopi nor elsewhere in the Lower Triassic of this region. Furthermore, the Kaibab, which is correlated with part of the Manzano group of New Mexico (the San Andres limestone), is itself Permian, a reference suggested first by the paleobotanic evidence from the underlying Supai formation and then corroborated by the invertebrates from the Kaibab itself. In brief, I think that we have here an almost perfect example of a boundary between two geologic systems, the formations being separated by a profound erosional unconformity and by an almost complete change of fauna, the upper formation containing many diagnostic

fossils of the later system and the lower formation containing many diagnostic fossils of the earlier system.

The Shinarump conglomerate has been accepted for many years as Triassic on the basis of its flora and fauna and its stratigraphic position and relations. The Chinle formation seems to be closely related to the Shinarump by its fossils, and its assignment to the Triassic is unquestioned.

The massive sandstone overlying the Chinle offers an opportunity for a wide difference of opinion. Emery⁵⁵ believed that the unit which near the San Rafael Swell almost certainly represents this sandstone was to be correlated entirely with the Wingate sandstone and that the marine Jurassic above it was Gregory's Todilto formation and a still higher formation the equivalent of the Navajo sandstone. Lee followed this view. Dake,⁵⁶ however, believes that this sandstone is equivalent to the whole La Plata group of Gregory and that the marine Jurassic above it is to be correlated with some part of the McElmo formation. The problem is essentially one to be solved by tracing in the field, though we believe that the character of the sandstone suggests a correlation with the whole La Plata group rather than with the Wingate alone, as there is in our area nothing like the Navajo sandstone above the marine beds. The marine series, however, contains peculiar greenish-white beds which somewhat resemble the greenish-white beds of the McElmo formation farther east. As mentioned on page 63 Walcott found in Kanab Valley in the top of the Chinle formation or the base of this sandstone fossils which have a Jurassic aspect.

The variegated shale would seem to belong to the same group as the marine Jurassic limestone, in that there are thin limestones in its upper part, though there may be an unconformity between the two and a considerable difference in age.

The buff sandstones yielded no fossils but suggest in position and lithology a correlation with the Cretaceous beds farther north and east, on Coal Creek, which have a thin coal-bearing unit at the base overlain by sandstones containing marine Cretaceous fossils. Still farther east, near Mount Carmel, appa-

⁵⁵ Emery, W. B., The Green River Desert section, Utah: Am. Jour. Sci., 4th ser., vol. 46, pp. 561-572, 1918.

⁵⁶ Dake, C. L., The horizon of the marine Jurassic of Utah: Jour. Geology, vol. 27, pp. 634-646, 1919 [1920].

rently the same interval contains, besides a basal conglomerate unit 15 feet thick, the coal-bearing unit, 400 feet thick; marine shale, 700 feet; sandstones and shale, 1,000 feet, overlain by a thin conglomerate; and 700 feet of fresh-water sandstone, apparently all Cretaceous.

The pink sandstone and shale series is believed from its position and character to be equivalent to the Tertiary rocks of the Pink Cliffs.

LOCAL SECTIONS.

1. Section in Hacks Canyon, Ariz.

[Upper part measured at mouth of Robesons Canyon; lower part measured along Hacks Canyon from Robesons Canyon to the point where it joins Kanab Canyon.]

Kaibab limestone:

Harrisburg gypsiferous member:	Feet.
Conglomerate, brown, of waterworn pebbles 1 inch in diameter; may be post-Mesozoic material.....	2
Limestone, yellow, arenaceous; weathers "sun-cracked." Silicified fossils on surface, including <i>Leda obesa</i> , <i>Ariculipecten?</i> sp., <i>Plagioglypta canna</i> , <i>Bucanopsis</i> aff. <i>B. bella</i>	8
Concealed interval.....	4
Sandstone, yellow, calcareous, and arenaceous limestone, with red chert and silicified fossils.....	25
Concealed interval.....	8
Limestone, impure, yellow. With units above is the " <i>Bellerophon</i> limestone.".....	4
Gypsum.....	18
Sandstone, light gray, calcareous.....	5
Limestone, with fragments of white chert that breaks into flat pieces, making up over half the bulk.....	13
Limestone, with white chert; fossiliferous.....	11
Limestone, with small chert nodules....	2
Limestone, arenaceous, yellow on weathering, white on fresh surface; more calcareous toward the top, more sandy and friable toward the base; resistant and ledge-forming.....	10
Gypsum.....	80
Thickness of Harrisburg member.....	190
Limestone, thin-bedded above, with much white chert; massive in middle, with much dark chert, which weathers brown or black; thin bedded in lower part.....	315
Gypsum, impure.....	125
Limestone, gray, massive; upper part cherty and relatively thin bedded, the chert nodules white and fossiliferous; beds of main part 1 to 3 feet thick; lower part grades down into sandstone, which is gray on weathered surface, white on fresh surface.	180
Limestone, thin bedded, not sandy.....	20
Thickness of Kaibab limestone.....	830

Coconino sandstone:	Feet
Sandstone, dark buff, locally salmon-colored, massive, cross-bedded, friable, medium to coarse grained.....	33
Sandstone, massive, medium grained, highly cross-bedded, friable, white, saccharoidal; a conspicuous unit. Along the strike this and the overlying unit may vary in relative thickness, so that the lower is four times as thick as the upper.....	44
Sandstone, massive bed with three distinct layers—a white massive cross-bedded sandstone with streaks of brown, 8 feet; hard brown sandstone, 2 feet; white argillaceous sandstone, 2 feet. Distinct from overlying unit in not being as white nor as friable.....	12
Thickness of Coconino sandstone.....	89

Supai formation:

Sandstone, massive, brick-red, with interbedded lenses of red shale; forms a cliff, or at least a steep slope.....	200
Sandstone, argillaceous, brick-red, and red sandy shale, interbedded, in about equal amounts.....	350
Sandstone, massive, brick-red, argillaceous; weathers into rounded ledges; one conspicuous white band and several minor ones. Base of unit not seen.....	525+
Thickness of part of Supai formation observed.....	1,075

2. Section in Toroweap Canyon, Ariz.

[Upper part measured 5 miles above mouth of Toroweap Valley; lower part at the mouth.]

Kaibab limestone:

Harrisburg gypsiferous member:	Feet.
Limestone, yellow, with silicified fossils at top of unit; concealed interval in middle; at base limestone filled with white chert that breaks into flat plates. " <i>Bellerophon</i> limestone".....	65
Gypsum.....	38
Limestone, dark blue.....	12
Gypsum.....	27
Limestone, impure.....	8
Gypsum.....	40
Thickness of Harrisburg member....	190
Limestone, massive, cherty, forming a series of steps.....	25
Limestone, gray, massive, with much dark-brown chert; forms cliffs and towers.....	160
Gypsum.....	175
Limestone, weathering white and hackly and forming steps.....	50
Limestone, gray, forming steps.....	50
Limestone, massive, fossiliferous throughout. At top blue, crystalline, cherty; grades downward into sandy limestone, locally a calcareous sandstone, fine grained; base argillaceous.....	100
Limestone, rather thin bedded, with nodules of dark chert, breaks with conchoidal fracture.....	25
Thickness of Kaibab limestone.....	775

Coconino sandstone:	Feet.	Coconino and Supai formations (undifferentiated):	Feet.
Sandstone, deep yellow to buff, somewhat friable but not notably cross-bedded.....	13	Sandstone, medium grained, gray to white on fresh surface, yellow-brown on weathered surface, medium bedded, cross-bedded....	200
Sandstone, much cross-bedded, yellow and white, friable; white on fresh surface.....	70	Sandstone, like that above but in thinner beds separated by softer brick-red sandstone. A few layers dark gray and smelling of oil when broken.....	490
Sandstone, pale yellow, fine grained, argillaceous; weathers to rounded exfoliated bosses.....	13	Sandstone, medium grained, cross-bedded, gray to white on fresh surface, yellow-brown on weathered surface; relatively thin bedded and weathering back from the unit beneath to form a bench.....	155
Thickness of Coconino sandstone.....	96	Sandstone, like the unit next above but practically in one bed and forming a sheer wall.....	380+
Supai formation:		Thickness of part of sandstone exposed....	1,225
Shale, gray, sandy.....	14		
Sandstone, red, somewhat argillaceous but massive and forming a steep slope or cliff....	175		
Sandstone, argillaceous, and sandy shale; both brick-red and interbedded in about equal amounts; forms a slope.....	375		
Sandstone, massive, red.....	735		
Thickness of Supai formation.....	1,299		
Redwall limestone.			
3. Section on Fredonia-Mount Trumbull road half a mile northeast of Bullrush, 12½ miles southwest of Fredonia, Ariz.		5. Section 2 miles south of Antelope Spring, on west side of Antelope Wash, Ariz.	
Moenkopi formation:	Feet.	Moenkopi formation:	
Shale, white, calcareous, and impure limestone in thin plates.....	5	Shale, red.	
Shale, red.....	18	Unconformity.	
Shale, gray.....	10	Kaibab limestone:	
Virgin limestone member:		Harrisburg gypsiferous member:	Feet.
Limestone, earthy, yellow, with many small cavities lined with calcite. Thickness ranges from 1 to 2 feet.....	2	Limestone, sandy, yellowish, with much white chert; very fossiliferous; weathers hackly, with silicified fossils showing on surface. Lithology characteristic of this part of the formation.....	15
Shale, gray.....	1	Gypsum, pink in large part; near middle of unit 5 feet of dark thin-bedded limestone with fetid odor when broken.....	140
Gypsum, red to gray.....	4	Sandstone, coarse, gray, granular, calcareous; contains fossil fragments.....	5
Shale, red.....	3	Thickness of Harrisburg member.....	160
Limestone, thin bedded, earthy, yellow; fossil fragments.....	1	Limestone, gray, massive, with much light chert; whole unit weathers light colored; exposed....	40
Thickness of Virgin limestone member.....	11		
Shale, red, exposed.....	25	6. Section at head of Rock Canyon, 5 miles north of Antelope Spring, Ariz.	
4. Section in Hurricane fault scarp in Black Rock Canyon, Ariz., 18 miles south of Hurricane, Utah.		Top of hill south of Rock Canyon.	
Kaibab limestone:	Feet.	Moenkopi formation:	
Limestone, gray, cherty, massive; inaccessible for measurement.....	225	Rock Canyon conglomeratic member:	Feet.
Gypsum, shale, and some limestone.....	190	Limestone, pale red, with some gray; weathers hackly and with "sun-cracked" surface and shows flecks of calcite.....	30
Limestone, gray and brownish on weathered surface, light gray on fresh surface; cherty. Unit massive except for uppermost 22 feet, which is thin bedded.....	5	Limestone, like unit above but gray.....	15
Sandstone, gray, fine grained; weathers brown.	15	Conglomerate of rounded and subangular fragments of quartz and chert, white to dark gray, as large as 12 inches across, though most are under 5 inches. The matrix is limestone. The bedding of this unit is very irregular, and locally the conglomerate is interbedded with ordinary limestone. Contains <i>Myalina</i> n. sp., <i>Monotis?</i> sp., <i>Macrocheilina?</i> sp.....	55
Gypsum.....	60	Conglomerate of fragments of fossiliferous chert and limestone in a matrix of white granular limestone. This unit is more resistant than that below. The unit above cuts down locally clear through this unit.	15
Limestone, thin bedded, gray.....	20		
Gypsum.....	7		
Limestone, thin bedded, dark gray.....	45		
Gypsum.....	567		
Thickness of part of Kaibab limestone measured.....			

Moenkopi formation—Continued.	
Rock Canyon conglomeratic member—Contd.	
Limestone, coarse, very fossiliferous, filled with large nodules of blue chert 1 inch to 1 foot in greatest dimension. The limestone weathers away, leaving the chert nodules with many fossils.....	15
Limestone, light gray, with crinoid fragments and some chert nodules. Surface usually dark from mosses and lichens. More resistant than units above and below.....	2
Limestone, white, knobby, chalky on fresh surface.....	2
Conglomerate of large blue limestone cobbles in a white granular matrix.....	2
Limestone, coarse, granular, base somewhat irregular; breaks into wedgy fragments....	10
Sandstone, soft, limestone, and limestone breccia, cherty in part and copper-stained locally.....	25
Limestone, light yellow, filled with white platy chert; beds rather thin.....	8
Sandstone, yellowish gray, medium grained, in beds 1 foot thick, passing along strike into sandy limestone; resistant unit.....	6
Thickness of Moenkopi formation exposed.....	185
Unconformity.	
Kaibab limestone:	
Harrisburg gypsiferous member absent or included in massive unit described below	
Limestone, gray, nodular, cherty; upper part thin-bedded, but unit massive as a whole.....	400
7. Section on north side of Rock Canyon at mouth, 15 miles south of Hurricane, Utah.	
Moenkopi formation:	
Rock Canyon conglomeratic member:	
Limestone, black, thin bedded, fossiliferous .	25
Limestone, dense, gray.....	70
Gypsum and red shale.....	100
Thickness of part of Moenkopi formation present.....	195
Unconformity.	
Kaibab limestone:	
Harrisburg gypsiferous member absent or included in massive unit described below.	
Limestone, massive, gray, with much brown to black chert; contains <i>Batostomella</i> sp., <i>Phyllopora?</i> sp., <i>Fenestella</i> sp., <i>Septopora</i> n. sp., <i>Orthotetes</i> sp., <i>Derbya</i> sp., <i>Chonetes hillanus?</i> , <i>Productus ivesi</i> , <i>Productus popei</i> , <i>Pustula subhorrida</i> , <i>Pustula subhorrida</i> var., <i>Pustula</i> aff. <i>P. irginae</i> , <i>Pugnax osagensis</i> var., <i>Spirifer</i> sp., <i>Squamularia guadalupensis</i> , <i>Composita subtilita</i> , <i>Myalina</i> aff. <i>M. deltoidea</i> , <i>Aviculipecten</i> sp., <i>Acanthopecten coloradoensis</i>	400
Gypsum, impure.....	55
Limestone, white, thin-bedded, cherty.....	20
Gypsum, impure.....	150
Limestone, upper part light colored, lower part gray; contains relatively little chert; not very resistant; weathers rather smooth, not hackly..	40

Kaibab limestone—Continued.	
Limestone, gray, cherty, massive; weathers hackly.....	175
Gypsum, earthy, gray, impure, with thin-bedded limestone and some gypsiferous sandstone.....	108
Thickness of Kaibab limestone.....	948
Coconino sandstone (?):	
Sandstone, deep yellow, friable.....	5
Sandstone, white, rather hard; forms ledge.....	2
Sandstone, soft, white, and sandy shale, light gray in great part but with some yellow staining.....	10
Thickness of Coconino sandstone (?).	17
Supai formation (?):	
Sandstone, yellow, friable.....	16
Sandstone, pale yellow, rather hard; massive bed forming sharp ledge.....	9
Sandstone, soft, gray, argillaceous.....	5
Sandstone, red and yellow interbedded, the yellow a little more resistant than the red....	55
Sandstone, mottled yellow and red.....	10
Sandstone, red, argillaceous, and red sandy shale.	30
Sandstone, massive, yellow, friable, cross-bedded, with several thin beds of red sandstone. Some of the yellow sandstone is white on a fresh surface and friable.....	35
Sandstone, massive, red, in beds 10 feet or more in thickness with thin beds (1 foot or less) of sandy shale between. On strike one of these beds grades into yellow sandstone; others are bleached yellow along cracks.....	40
Sandstone and shale, red, micaceous, interbedded in subequal amounts.....	100
Sandstone, massive, brick-red, somewhat argillaceous, with thin beds of red shale.....	35
Sandstone, white, friable.....	17
Sandstone, massive, brick-red, argillaceous, with thin beds of interbedded red sandy shale. On strike some of these beds are yellow locally.	148
Exposed.....	148
Thickness of Supai formation (?) exposed.	500
8. Section on Hurricane fault scarp 6 miles south of Hurricane, Utah.	
[See Pl. IX, A, B.]	
Basalt.	
Moenkopi formation:	
Shale, red sandy, present.....	100±
Unconformity.	
Kaibab limestone:	
Harrisburg gypsiferous member:	
Limestone, gray, thin bedded, some of it containing angular fragments of chert; and shale, gray or yellow. Unit unresistant to weather. May possibly be basal Moenkopi.....	45
Limestone, brownish to yellow, with some dark-gray layers; some layers brecciated.	115
Thickness of Harrisburg member.....	160
Limestone, massive, gray, with much brown chert; fossils abundant in chert.....	260

Kaibab limestone—Continued.	
Shale, soft sandstone, and gypsum, the whole forming a gray slope.....	200
Limestone, gray, massive, with much brown chert; light colored on fresh surface; contains softer shaly layers near middle of unit.....	230
Limestone, sandy, cream-colored, cross-bedded, platy. Some limonitic staining shows.....	25
Limestone, thin bedded, dark drab, with oily odor; contains some soft sandy layers and some white chert in nodules.....	10
Gypsum, white, pure.....	20
Gypsum, gray; has some odor of oil.....	10
Gypsum, white, massive, with some thin gray sandstone layers.....	15
Thickness of Kaibab limestone.....	930
Cocconino sandstone (?):	
Sandstone, creamy yellow.....	20
Sandstone, white.....	45
Supai formation (?):	
Sandstone, medium grained, cross-bedded, ripple marked, yellow-brown to light gray, exposed.....	200±
9. Section near sulphur spring at mouth of Virgin Canyon, half a mile south of La Verkin, Utah.	
Moenkopi formation:	
Rock Canyon conglomeratic member:	Feet.
Limestone, dark colored, platy, with an abundance of <i>Bakewellia</i> n. sp. (small form).....	1
Concealed interval covered with loose fragments of various sorts of limestone....	35
Thickness of part of Moenkopi formation measured.....	36
Unconformity.	
Kaibab limestone:	
Harrisburg gypsiferous member:	
Limestone, variable; some of it with much light-colored platy chert, dark gray and hackly on weathered surfaces, yellow and light gray on fresh surfaces; some layers sandy and others much like the lower parts of the Kaibab formation with dark chert nodules. Some layers fossiliferous, containing <i>Chonetes hillanus</i> , <i>Squamularia guadalupensis</i> , <i>Composita</i> sp.....	75
Limestone, sandy limestone, calcareous sandstone, white, yellow, and gray friable sandstone, and some gypsum.....	75
Thickness of Harrisburg member....	150
Limestone, gray, cherty, resistant, massive; has a cap layer filled with light-colored platy chert.....	280
Limestone, gray, cherty, less resistant than unit above and broken into a series of terraces. Some breccia and some gypsum present....	50
Gypsum, white.....	50
Limestone, gray, cherty, very resistant, massive, exposed.....	200
Thickness of Kaibab limestone exposed..	766

10. Section in Virgin River canyon 3 miles west of Virgin City, Utah.	
Moenkopi formation:	
Red beds and gypsum.	Feet.
Sandstone, grayish brown, hard, very platy:...	3
Shale and sandy shale, yellow.....	5
Sandstone, brown, hard, platy.....	5
Shale, sandy, soft yellow.....	20
Rock Canyon conglomeratic member:	
Limestone, dark gray, hackly; reddish locally and rough from weathering out of sandy fragments.....	8
Limestone, pink and gray, sun-cracked; weathered surface shows flecks of white calcite. On strike this unit becomes a breccia in lower part.....	28
Limestone, massive, yellow, with fossils showing on weathered surface. Beds 1 to 2 feet thick. This unit and unit below thin out on strike and breccias above and below unite.....	10
Concealed interval chiefly, but with some gray limestone.....	18
Breccia of chert and limestone in a limestone matrix; many fragments large (6 inches or more across), many angular. Variable unit.....	10
Interval largely concealed but with some sandy yellow limestone and shale and some gray limestone showing.....	18
Limestone, massive, bluish, with light-colored chert.....	45
Concealed interval of soft beds forming slope....	35
Thickness of part of Moenkopi formation observed.....	172
Unconformity.	
Kaibab limestone:	
Harrisburg gypsiferous member absent?	
Limestone, bluish, with much black and dark-gray chert.	
A short distance from the point of measurement of this section 3 feet of soft sandstone rests upon the cliff-forming limestone, and above this is a massive breccia, whose matrix is locally brick-red and which makes up almost all of the Rock Canyon conglomeratic member.	
11. Section in Virgin Canyon 2½ miles west of Virgin City, Utah, below the mouth of Oil Scep Wash.	
Moenkopi formation:	
Rock Canyon conglomeratic member:	Feet.
Limestone, brown, full of large sand grains that weather out on surface.....	1
Concealed interval.....	5
Limestone, gray; weathers hackly.....	3
Concealed interval.....	8
Limestone, sandy, gray; weathers hackly....	4
Concealed interval.....	17
Shale, yellow, sandy.....	4
Concealed interval.....	12
Limestone conglomerate, gray, fine grained; weathers hackly.....	15
Limestone, gray, with reddish patches.....	10
Limestone, red, interbedded with red shale and a reddish mottled limestone.....	60

Moenkopi formation—Continued.	Fe. t.
Rock Canyon conglomeratic member—Contd.	
Limestone breccia, gray.....	10
Sandstone, yellow and gray, with sandy shale and shale.....	15
Limestone conglomerate, grayish brown.....	5
Thickness of part of Moenkopi formation measured.....	169
Unconformity.	
Kaibab limestone:	
Harrisburg gypsiferous member absent?	
Limestone, gray, cherty.	
12. Section in Virgin Canyon 2 miles west of Virgin City, Utah, at mouth of Oil Scep Wash.	
Moenkopi formation:	
Rock Canyon conglomeratic member:	Feet.
Limestone, gray, nodular; undeterminable fossils.....	1
Concealed interval.....	5
Limestone conglomerate, hackly and very rough on weathered surface.....	18
Limestone, gray, sun cracked and flecked with calcite.....	9
Limestone, red.....	20
Limestone conglomerate and breccia with fragments as much as 2 feet in diameter; matrix yellow limestone.....	15+
13. Section in Smith's Mesa, 3 miles north of Virgin City, Utah.	
Jurassic sandstone.	
Chinle formation:	Feet.
Shale and sandstone, brick-red; estimated (not present in Smith's Mesa, but seen at a point near by).....	200
Sandstone, mauve, cross-bedded, ripple marked, resistant.....	90
Shale and sandstone, brick-red.....	420
Sandstone, coarse, arkosic, cross-bedded, gray-white and mauve; suggests volcanic ash; contains fossil wood. Locally known as the "Silver Reef sandstone".....	25
Shale "gumbo," variegated, bluish gray, greenish, mauve, red, and some yellow-brown; contains fossil wood.....	260
Thickness of Chinle formation.....	995
Shinarump conglomerate (Pl. XIII, A):	
Sandstone, gray, platy, with a few pebbles....	20
Shale, gray to green, with some fossil wood....	20
Sandstone, coarse, gray-white on fresh surface, limonitic brown on weathered surface; locally filled with black blebs of wad or some similar substance. Contains lenses of pebbles of chert, variously colored, quartz, silicified wood, and minor igneous rock. Base is irregular and apparently unconformable. Unit contains abundance of fossil logs, mostly silicified, though in part replaced by copper minerals.....	75
Thickness of Shinarump conglomerate....	115

Moenkopi formation:	Feet
Sandstone, soft, and shale, brick-red to very deep red, with gypsum and a little lighter-colored shale; weathers to a fairly even slope.....	405
Shnabkaib shale member: Shale, sandy, and sandstone, soft, fine-grained, creamy white, with some pinkish layers and gypsum; weathers to a fairly even slope.....	360
Sandstone and shale, brick-red, and light bluish-gray gypsum, lighter colored than the upper red beds.....	400
Virgin limestone member:	
Limestone, yellow, earthy, fossiliferous; contains <i>Myalina</i> n. sp., <i>Pseudomonotis</i> n. sp., <i>Bakewellia</i> n. sp.....	5
Shale, yellow and red.....	25
Limestone, yellow, earthy, fossiliferous; contains <i>Myalina</i> n. sp., <i>Pseudomonotis</i> n. sp.....	5
Shale, yellow, calcareous.....	25
Limestone, fairly massive, yellow, earthy; contains <i>Isocrinus</i> sp., <i>Spirorbis</i> sp., <i>Terebratulula?</i> n. sp., <i>Pinna?</i> sp., <i>Bakewellia</i> n. sp., <i>Pseudomonotis</i> n. sp., <i>Myalina</i> n. sp., <i>Ariculipeecten</i> , 4 sp., <i>Myophoria?</i> sp., <i>Pleurophorus?</i> sp., <i>Pleurotomaria?</i> , 2 sp., <i>Naticopsis</i> sp., ammonite? undet.....	20
Thickness of Virgin limestone member.....	80
Sandstone and shale, brick-red, with gypsum..	360
Rock Canyon conglomeratic member: Irregular basal unit of limestone, conglomerate, etc....	170
Thickness of Moenkopi formation.....	1,775
Kaibab limestone (see sections in Virgin River canyon).	
14. Section at the Harrisburg dome, 8 miles east of north of St. George, Utah.	
Shinarump conglomerate.....	100±
Moenkopi formation:	
Shale and sandstone, brick-red, upper part very dark colored.....	320
Sandstone, yellow, medium grained, massive in upper part.....	75
Shale, red, with some sandstone and gypsum..	80
Shnabkaib shale member: Shale, sandy, white to light gray, with gypsum and some pink shale.....	630
Shale, red, sandy, with gypsum.....	435
Virgin limestone member: Limestone, earthy, greenish yellow, in three thin bands separated by greenish-yellow and reddish-brown shale. Lower band contains <i>Isocrinus</i> sp., <i>Pugnax</i> n. sp., <i>Ariculipeecten</i> sp..	160
Shale, red, some of it sandy, with gypsum and a little bluish gypsiferous shale.....	275
Shale, yellow, gypsiferous, containing locally thin black limestone layers with <i>Bakewellia</i> n. sp. (small form).....	60
Rock Canyon conglomeratic member apparently absent.	—
Thickness of Moenkopi formation.....	2,035

Unconformity.

Kaibab limestone:

Harrisburg gypsiferous member: Limestone, varying in character in different layers, some of the upper ones pinkish and sun cracked, others showing a coarse matrix with much angular chert. Still other layers have much whitish chert with platy fracture, and some in the lower part of the unit resemble the older part of the Kaibab with dark chert. Variation in character laterally is very great. Three collections at about the same horizon at different places near the top of the limestone show the following fossils: (1) <i>Productus ivesi</i> , <i>Pustula subhorrida</i> ; (2) <i>Lithostrotion?</i> n. sp., <i>Favosites?</i> n. sp., <i>Campophyllum?</i> n. sp.; (3) <i>Diclusma</i> sp., <i>Nucula levatiformis</i> , <i>Leda obesa</i> , <i>Pteria</i> (<i>Bakerellia?</i>) sp., <i>Pseudomonotis?</i> sp., <i>Schizodus wheeleri?</i> , <i>Pleurophorus mexicanus</i> , <i>Platyglypta canna</i> , <i>Bucanopsis</i> aff. <i>B. bella</i> , <i>Euphemus</i> sp., <i>Goniospira</i> sp., <i>Pleurotomaria</i> sp., <i>Naticopsis?</i> , <i>Platuccras</i> sp.	250
Shale, yellow, gypsiferous.	30+

[Section continued by the log of the well of the Virgin Dome Oil Co.]

Kaibab limestone:

Limestone of varying hardness and color and some gypsum, composing the Harrisburg gypsiferous member, 258 feet. As well mouth is 12 feet beneath top of Harrisburg member the thickness is close to that found on surface.	[270]
Limestone, light colored, containing much chert.	275
Limestone, salmon-colored, soft.	38
Limestone, etc. (details not known).	466
Thickness of Kaibab limestone.	1,049
Cocconino sandstone and Supai formation:	
Sandstone to bottom of well.	1,150

15. Section in the Washington dome, 6 miles east of St. George, Utah.

Moenkopi formation:	Feet.
Virgin limestone member.	160±
Lower red-beds member.	320±
Rock Canyon conglomeratic member:	
Limestone, dark gray, thin bedded, with some light-colored limestone; contains <i>Bakerellia</i> n. sp. (small form) and <i>Myophoria</i> sp.	10
Shale, dark red, with gypsum stringers.	33
Concealed interval, possibly red shale.	57
Coarse conglomerate of limestone and chert in a limestone matrix, the whole pinkish.	11
Shale, red and yellow, some of it sandy.	5
Limestone, coarse, pinkish, with chert fragments.	4
Concealed, probably shale.	8
Limestone, pinkish, containing large boulders of limestone and chert.	20
Limestone, gray, rough, silicified, with some chert nodules.	12

Moenkopi formation—Continued.

Rock Canyon conglomeratic member—Contd.	Feet.
Coarse conglomerate of limestone in a lime matrix grading upward into a gypsum matrix.	53
Gypsum, pure, massive.	10
Limestone, porous, gray, somewhat silicified.	2
Gypsum with much fine-grained platy drab to dark-gray limestone; some breccia.	83

Unconformity.

Kaibab limestone:

Harrisburg gypsiferous member absent locally, but present here and there and containing *Schizodus* sp., *Platyglypta canna?*, *Bellerophon majusculus?*, *Goniospira* sp., *Euomphalus* sp., *Nautilus* sp.
Massive cherty gray limestone.

16. Section at the Bloomington dome, 5 miles south of St. George, Utah.

Moenkopi formation:	Feet.
Virgin limestone member.	130±
Lower red-beds member: Shale, red, some of it sandy, and gypsum. Near base contains gypsum with thin limestones and <i>Bakerellia</i> n. sp. (small form).	320±

Unconformity.

Kaibab limestone:

Harrisburg gypsiferous member:

Limestone, gray, filled with angular pieces of chert that break into plates. This unit is crumbly, and weathered edges of blocks are rounded.	12
Limestone, like unit above, but in a single bed, harder and weathering into angular blocks with included chert projecting as brown excrescences on surface.	2
Breccia of quartz fragments loosely cemented by limestone; friable and non-resistant.	1
Limestone, gray, coarse, granular.	3
Limestone, gray, very soft, non-resistant.	6
Gypsum.	4
Limestone, white, granular; weathers to powder. Contains partly silicified fossils, including <i>Polypora</i> sp., <i>Chonetes hillanus?</i> , <i>Squamularia guadalupensis</i> , <i>Composita</i> n. sp.	5
Limestone, dark gray, coarse grained, friable, non-resistant; fossiliferous.	5
Limestone, gray, thin bedded, with nodules of chert.	4
Gypsum, pinkish, with a 5-foot bed of dark limestone 10 feet above base.	215
Limestone, gray, filled with fragments of chert that breaks into plates.	5
Concealed interval.	5
Limestone, soft, gray, with well-preserved silicified fossils.	5

Thickness of Harrisburg member. 272

Kaibab limestone—Continued.

Limestone, gray, massive, resistant, with much dark chert; contains <i>Batostomella</i> sp., <i>Fenestella</i> sp., <i>Polypora</i> sp., <i>Septopora</i> sp., <i>Productus ivesi</i> , <i>Pustula subhorrida</i> , <i>Pustula</i> aff. <i>P. irginae</i> , <i>Pseudomonotis?</i> sp., <i>Aviculipecten</i> , 3 sp., <i>Acanthopecten coloradoensis</i> , <i>Acanthopecten?</i> sp.	100±
---	------

17. Section just off the St. George-Wolf Hole road about 7 miles north of Wolf Hole, Ariz.

Top of hill.
Kaibab limestone:

Harrisburg gypsiferous member (some of this unit may be basal part of Moenkopi formation):	
Gypsum, red, in thin layers.....	15
Gypsum, white.....	18
Gypsum, red, with a little red shale.....	5
Gypsum, white to pink.....	10
Limestone, white, with little or no chert..	2
Sandstone, brown to yellow, soft, and gypsum.....	7
Limestone, yellowish, filled with white platy chert.....	15
Gypsum.....	15
Limestone, white, earthy to sandy; white on a fresh surface, yellow to white on weathered surface; chert nodules abundant in lower part.....	17
Gypsum, white to pink, with a little limestone.....	148
Limestone thickly set with white platy chert; has a peculiar brown fibrous surface.....	3
Concealed interval.....	4
Thickness of Harrisburg member...	259
Limestone, gray, with many nodules of dark chert that are brown or black on a weathered surface.....	315
Limestone, sandy; weathers white and contains little chert; not very resistant to weather...	15
Gypsum, with some shale and limestone.....	270
Limestone, cherty, gray; exposed.....	150
Thickness of part of Kaibab limestone exposed.....	1,009

18. Section near Black Rock Spring, Ariz., 25 miles south of St. George, Utah.

Moenkopi formation:

Middle red beds.	
Virgin limestone member:	
Limestone, earthy, yellow.....	9
Shale, red.....	36
Limestone, earthy yellow.....	5
Shale, red.....	26
Limestone, earthy yellow, containing <i>Isocrinus</i> sp., <i>Myalina</i> sp., <i>Bakewellia</i> n. sp., <i>Monotis?</i> sp.....	24
Thickness of Virgin limestone member.....	100
Shale, red.....	113

Moenkopi formation—Continued.

Shale, red, with prominent beds of bluish gypsum.....	22
Shale, red.....	8
Shale, red, with much gypsum.....	10
Gypsum, reddish.....	17
Gypsum, impure, yellowish brown.....	10
Thickness of part of Moenkopi formation measured.....	280

Unconformity.
Kaibab limestone:

Harrisburg gypsiferous member:	
Limestone, gray, filled with nodules of white chert that breaks with a platy fracture.....	25
Concealed interval, less resistant beds....	10
Limestone, granular; weathers white with a very hackly surface; contains <i>Chonetes hillanus</i> , <i>Squamularia guadalupensis</i>	7
Limestone, soft; weathers yellowish and contains many nodules of light-colored chert which does not break into plates..	8
Gypsum, in part pinkish.....	43
Limestone, dark; weathers rough and has fetid odor when broken.....	4
Concealed interval, probably gypsum.....	8
Limestone, gray, with much platy chert...	4
Concealed interval.....	1
Thickness of Harrisburg member...	110
Limestone, gray, with much dark-colored chert that shows as black or brown excrescences on weathered surfaces.....	250

19. Section in narrows of Virgin River below Bloomington, Utah.

Kaibab limestone:

Harrisburg gypsiferous member:	
Limestone, hackly, very light gray to almost white, with small dark-colored chert nodules showing on weathered surfaces.....	7
Limestone, white on both fresh and weathered surfaces.....	5
Concealed interval.....	3
Limestone, yellowish, filled with white or light-gray chert which breaks into plates; a very characteristic rock.....	15
Concealed interval.....	10
Limestone, light blue-gray, with some chert nodules that stand out upon weathered surfaces; fossiliferous; upper part particularly "flinty".....	15
Concealed interval.....	12
Limestone, porous, white, gypsiferous...	1½
Shale, red.....	10
Conglomerate and breccia of limestone with red earthy gypsiferous matrix....	14
Shale, red and yellow, soft, sandy.....	7
Limestone and shale, earthy, gray, gypsiferous.....	4
Shale, red and yellow, soft, sandy.....	8

Kaibab limestone—Continued.

Harrisburg gypsiferous member Continued.

Limestone breccia, hackly on weathered surface, pinkish locally but light blue-gray in general tone; sun-cracked on weathered surfaces; a very characteristic rock	7
Lime shale, gray to yellow, sandy, with a little white chert in bands.	4
Limestone, soft, porous, pink, yellow, and gray in color; weathers to a hackly or cavernous surface.	7
Limestone breccia, dark blue-gray, with hackly surface, more resistant than unit above.	5
Limestone breccia, relatively soft; matrix a yellow limestone. Fragments in breccia as large as 4 inches in diameter.	2

Thickness of Harrisburg member.

Feet.

7
4
7
5
2

137

[Remainder of section measured farther down canyon.]

Limestone, thin bedded, ash-gray, with some layers of chert breccia and calcareous shale. Possibly duplicates part of the beds described above.	70
Limestone, massive, uniform, fine grained, gray on fresh surface and brownish on weathered surface; filled with layers and nodules of brown chert; fossiliferous throughout.	275
Breccia of limestone and chert in a limy matrix; whole mass weathers to a yellow-brown color.	110
Gypsum and red shale.	50
Breccia of limestone and white chert in limy matrix.	20
Shale, soft, gray, and gypsum.	10
Limestone, very massive, gray to light gray on weathered surface, cherty, fossiliferous.	220
Sandstone, soft, yellow, gypsiferous.	8
Limestone, gray to brown, very cherty, thin bedded.	32
Limestone, arenaceous, light gray to white, cherty.	25

Thickness of Kaibab limestone.

957

Coconino sandstone (?):

Sandstone, coarse grained, cross-bedded, brown on weathered surface, buff on fresh surface.	15
Sandstone, white on fresh surface, dark gray or blackish on weathered surface, cross-bedded; variable along strike.	5
Sandstone, white to cream-colored, earthy, fine grained; locally upper part of unit whiter than lower part.	25

Thickness of Coconino sandstone (?).

45

Supai formation (?): Sandstone, medium grained, cross-bedded, very massive; lower part yellow and brown, with a little irregular red staining; middle part similar but with much red staining and a few thin soft red sandstones; upper part in some places a uniform red but usually a clean yellow-brown. The unit is so uniform that it can not be subdivided. No fossils observed. 1,490

Feet.

Redwall limestone: Limestone, siliceous, and sandstone, mostly heavy bedded, light gray on fresh surface, red-brown to dark gray on weathered surface. About 200 feet below the top of the exposure a marked dark-gray layer 20 feet thick looks as if it might be stained by hydrocarbons but shows none on a test. Fragments of fossils observed. 500+

20. Section in Beaver Dam Mountains near Arrowhead Trail from Salt Lake City to Los Angeles, about 20 miles northwest of St. George, Utah.

Moenkopi formation.

Unconformity.

Kaibab limestone:

Feet

Harrisburg gypsiferous member (some of this unit may be basal part of Moenkopi formation):

Limestone, very light gray, almost white.	4
Limestone, hackly, darker than overlying layer.	4
Limestone, dark gray, with a few fossils.	6
Concealed interval; fragments of gray limestone on surface.	4
Concealed interval; fragments of platy quartz and chert on surface.	15
Limestone, filled with platy chert of very light color.	17
Limestone, pink and gray, with hackly surface, fossiliferous.	11
Limestone, yellowish, thin bedded.	10
Limestone, gray to pinkish, with hackly surface, fossiliferous.	8
Concealed interval.	12
Limestone and platy white chert, in equal amounts. Weathered surface has a peculiar brown, fibrous appearance.	16
Concealed interval.	39
Limestone, gray, with hackly surface.	5
Concealed interval.	28

Thickness of Harrisburg member.

184

Limestone, gray, cherty, massive.

195

Interval mostly concealed but with some fossiliferous limestone showing; probably much of it gypsum.

260

Limestone, massive, gray, cherty.

170

Limestone, yellowish to white, very sandy; some nodules of calcite present. Lower part especially friable where exposed to weather.

10

Concealed.

75

Thickness of Kaibab limestone.

924

Coconino and Supai formations: Sandstone, very massive but not hard, medium grained, predominantly pale yellow but locally pinkish. Through much of it there are specks of iron oxide that stand out over the weathered surface in brown pimples. The upper part of the sandstone is a lighter yellow and has very little pink coloring; the lower part is darker, has more pink coloring, and is thinner bedded. 1,420

Redwell limestone: Limestone, gray, earthy, porous; reddish or brownish on weathering. Only fossils collected are *Chaetetes milleporaceus*, at about 1,000 feet beneath top of formation, and *Marginifera* aff. *M. splendens*, at 650 to 700 feet beneath top of formation. 1,500+

21. Section on north side of Diamond Valley, 15 miles north of St. George, Utah.

Tertiary or Quaternary: Basalt flow. Feet.

Tertiary (?) sandstone: Sandstone in massive beds, medium grained, yellow with some red staining, separated by soft sandstone, much of it red, and red shale. As a mass viewed from a distance this series is pink and contrasts with the yellow sandstone below. No fossils seen. Thickness of part visible (estimated) 1,500

[The exposure of the pinkish sandstone unit described above lies 3 miles south of the exposures described below, but viewed from a distance and considering isolated exposures between it seems to succeed the lower beds with very little interval or overlapping.]

Cretaceous (?) sandstone:

Sandstone, heavy bedded, medium grained, buff. 300±

Sandstone, red and purplish, with some shaly layers. 55

Sandstone, buff and white, heavy bedded. . . 115

Sandstone, buff to white, medium grained; in heavy beds with soft sandstone and shale between. Lowest bed has dark limonitic joint surfaces. 290

Shale, gray, clayey, and gray carbonaceous sandstone that contains plant fragments. . . 30

Quartzite, dense, reddish and gray, fine grained. 3

Sandstone, light gray to brown, dense, with intercalated gray and purple shale. Some of the sandstone has carbonaceous matter, and much of it is soft, though hard layers stand out here and there. 90

Thickness of Cretaceous (?) sandstone. 883±

Cretaceous (?) shale:

Shale, steel-gray "gumbo" 40

Shale, brick-red, with some thin layers of white limestone. 55

32333°—22—6

Cretaceous (?) shale—Continued. Feet.

Shale, greenish gray, sandy and platy sandstone. 45

Thickness of Cretaceous (?) shale. 140

Jurassic limestone and shale:

Limestone, platy, brownish gray, crystalline; oolitic in part; *Pentacrinus* and *Ostrea* scattered over surface. 2

Shale and platy limestone, light gray with greenish cast; some of it oolitic, some sandy. The limestone is dense and hard. *Trigonia* and other pelecypods present sparingly. . . 145

Limestone, brownish, dense, platy. 5

Limestone, laminated, dense, light gray; fossils very scarce. 20

Limestone, soft, earthy, cream-colored; might perhaps be called a calcareous shale. 35

Limestone, dense, cream-colored; breaks with conchoidal fracture and is very fine grained. 15

Limestone, soft, earthy, cream-colored. . . . 10

Limestone, dense, hard, cream-colored; with conchoidal fracture. 10

Limestone, hard and soft, alternating in thin beds. 15

Gypsum, with some bluish-gray shale. . . . 20

Shale, cream-colored, calcareous. 15

Limestone, dense, hard, cream-colored; a few poorly preserved pelecypods observed. . . . 5

Shale, greenish gray. 15

Shale, brick-red. 5

Gypsum. 10

Shale, brick-red; exposed. 50

Interval, mostly concealed, probably red shale and sandstone. 100±

Thickness of Jurassic limestone and shale. 477±

Jurassic sandstone: Sandstone, white, coarse grained, with marked eolian cross-bedding. Thickness not determined.

22. Section through basal beds of Moenkopi formation at head of Virgin Narrows, 3 miles southwest of Bloomington, Utah.

Moenkopi formation: Feet.

Rock Canyon conglomeratic member:

Conglomerate of pebbles and angular fragments of limestone and chert as much as 1 inch in diameter. 2

Concealed interval. 8

Conglomeratic sandstone, grayish brown. 3

Conglomerate of chert pebbles with some limestone pebbles; limestone cement. Pebbles as much as 5 inches in diameter. Individual beds 5 feet thick. 60

Kaibab limestone:

Harrisburg gypsiferous member absent.

Limestone, hard, cherty, gray.

THE BYRAM CALCAREOUS MARL OF MISSISSIPPI.

By C. WYTHE COOKE.

HISTORICAL INTRODUCTION.

The beautiful and well-preserved shells contained in the lower Oligocene deposits at Vicksburg, Miss., early attracted the attention of collectors. Lesueur appears to have been the first to depict them, and the set of five plates engraved by him in 1829 shows a number of the species at Vicksburg. However, as his plates were not accompanied by names or descriptions, all the Vicksburg species date from later authors. His name, although not attached to any of the species as author, is perpetuated by *Scapharca lesueuri* Dall, one of the most common and most characteristic mollusks of the Byram marl. Conrad, the Nestor of American Tertiary paleontologists, in 1848¹ described and figured a large number of fossil mollusks from Vicksburg. Since that time many collectors have visited Vicksburg, and specimens from the marls are contained in many cabinets, but no one has attempted a systematic study of the fossils.

Nearly every student of the Vicksburg beds has recognized a twofold or a threefold division of the group. Conrad collected chiefly from the topmost marls, but that he was aware of the presence of a lower shell bed and that five of his species came from it is plainly stated on pages 207-208 of the volume cited. Hilgard, in his monumental work on the geology of Mississippi,² published a characteristic section of the bluff at Vicksburg but did not propose names for the various beds. Otto Meyer³ in 1885 distinguished three members of the Vicksburg, for which he proposed the names "Higher Vicksburgian," "Middle Vicksburgian," and

"Lower Vicksburgian." The middle and lower divisions of Meyer constitute but one horizon, in the opinion of Casey,⁴ who says:

At Vicksburg there are two distinct horizons. * * * The lower Vicksburgian consists of alternate thin strata of gray sands, sandy clays, and variably but usually loosely compacted white or gray limestone. The upper consists of a much thinner bed of more or less red-brown marl, often indurated into nodular masses or subindurated, and without trace of limestone, having rarely, however, thin layers of glauconitic sands and comminuted shells, in which entire specimens when found are generally much distorted by pressure. The faunas of these two beds differ very markedly.

In 1918 I proposed names for the several formations of the Vicksburg group⁵ and drew up the correlation table shown on page 80. The detailed evidence upon which this correlation is based is still awaiting publication.

The present paper is designed to describe briefly the youngest formation of the Vicksburg group, the Byram marl, to give an account of its more notable exposures in Mississippi, and to enumerate some of the fossil species that have been found in it. The formation is more fully described in a manuscript by me awaiting publication by the Mississippi State Geological Survey. I hope before long to undertake the systematic description of the mollusks of the Vicksburg group.

GENERAL FEATURES.

The topmost formation of the Vicksburg group, the Byram calcareous marl, is named from the village of Byram, on Pearl River, Miss., about 9 miles below Jackson. The Byram beds were supposed by Casey⁶ to constitute a "substage" intermediate in age between the Red Bluff clay and the Mint Spring marl, but more detailed study of the mollusks

¹ Conrad, T. A., Observations on the Eocene formation and descriptions of 105 new fossils of that period from the vicinity of Vicksburg, Miss.: Acad. Nat. Sci. Philadelphia Jour., 2d ser., vol. 1, pp. 111-134, 1848; Descriptions of new fossil and recent shells of the United States: Idem, pp. 207-209, 1849.

² Hilgard, E. W., Report on the geology and agriculture of the State of Mississippi, p. 141, 1860.

³ Meyer, Otto, The genealogy and the age of the species in the southern Old Tertiary, pt. 2: Am. Jour. Sci., 2d ser., vol. 30, p. 71, 1885.

⁴ Casey, T. L., On the probable age of the Alabama white limestone: Acad. Nat. Sci. Philadelphia Proc., vol. 53, p. 515, 1901.

⁵ Cooke, C. W., Correlation of the deposits of Jackson and Vicksburg ages in Mississippi and Alabama: Washington Acad. Sci. Jour., vol. 8, p. 187, 1918.

⁶ Op. cit., pp. 517-518.

and corals shows that the marl at Byram is of the same age as the upper shell bed at Vicksburg, and this correlation is entirely corroborated by the evidence of the Bryozoa and the Foraminifera.

The Byram marl lies conformably upon the Glendon limestone member of the Marianna limestone. The relations of the Byram marl to the overlying Catahoula are conjectural. At Vicksburg the transition from one formation to the other is so gradual that deposition appears to have been continuous from the Vicksburg into the Catahoula, but at Waynesboro the change in lithology is so abrupt as to suggest the probability of an interruption in deposition. However, no unequivocal evi-

At Vicksburg, where the entire thickness of the Byram marl is exposed, the formation is only 42½ feet thick. On Chickasawhay River, in eastern Mississippi, incomplete exposures indicate a thickness of at least 70 feet. Because of the softness of the Byram marl, exposures are few and usually incomplete, and in many places the whole formation is covered. The outcrop of the Byram marl extends entirely across the State of Mississippi. Exposures are known on Mississippi, Pearl, Leaf, and Chickasawhay rivers and at a few intermediate places, and strata of the same age have been found at several places in Alabama.

No marked physiographic features are due to the Byram marl. The soft, easily eroded

Correlation of the Jackson and Vicksburg deposits in Mississippi and Alabama.

Age		Mississippi		Alabama		
Oligocene	Vicksburg group	Byram calcareous marl				Marianna limestone
		Glendon limestone member				
		Marianna limestone	Mint Spring calcareous marl member	"Chimney rock" facies		
		Forest Hill sand	Red Bluff clay			
Eocene	Jackson formation	Yazoo clay member		Ocala limestone		
		Moodys calcareous marl member				

dence of unconformity between the two formations has been observed.

Although the Byram marl, being the formation from which Conrad obtained most of his fossils from Vicksburg and upon which he based his description of the Vicksburg group, is the type formation of the group; it is not nearly so conspicuous as the Marianna limestone, which underlies it, and this has given rise to the erroneous impression that the Vicksburg group consists chiefly of limestone. The formation, as the name indicates, consists largely of marl, but it contains also thin beds of impure limestone, clay, and sand. The marl is generally sandy and contains considerable glauconite. On natural outcrops it is of a rusty yellowish color, but where less weathered it is gray or green.

strata usually form gentle slopes between the harder Glendon limestone member of the Marianna limestone, below, and the Catahoula sandstone, above. At some places the Byram marl has been eroded back from the edge of the Glendon limestone, leaving the hard ledges of the Glendon projecting as a broad platform or terrace

LOCAL DETAILS.

VICINITY OF VICKSBURG.

Exposures of the Byram marl occur at several places near Vicksburg. The best and most complete is on the Park Road leading southward up the hill from Waltersville past the north side of the National Cemetery. Bed 1 of the following section, which shows the entire thickness of the Byram marl as well as parts of the adjacent formations, was found

in a ravine 11 feet below the wagon bridge on the east side of Waltersville.

Section between Waltersville and the National Cemetery.

	Feet.
12. Loess.....	25±
11. Coarse gravel, pebbles 2 inches in maximum length, in matrix of irregularly grained sand.	13
Catahoula sandstone (?):	
10. Fine gray laminated sand.....	25
Byram marl:	
9. Lower 10 feet consists of a shell bed with <i>Scapharca lesueuri</i> , etc., at base, overlain by 1½ feet of brownish fossiliferous clay grading upward into yellowish ferruginous, glauconitic sandy marl with shells. Upper part is prevalingly brown clay with patches of marl, with shells locally abundant. Top is yellowish-gray, sparingly glauconitic, ferruginous shell marl with <i>Ostrea vicksburgensis</i> , <i>Pecten poulsoni</i> , etc.	38
8. Gray or brown argillaceous marl and brown clay with occasional plant remains associated with mollusks. Shells especially abundant near the top. <i>Dentalium mississippiense</i> , <i>Pecten poulsoni</i> , etc.	4.5
Marianna limestone (Glendon limestone member):	
7. Gray glauconitic, somewhat indurated marl with poorly preserved fossils. Nodular in upper part.....	4.5
6. Blue-gray or gray fossiliferous glauconitic argillaceous marl with some stiff blue clay at top. <i>Lepidocyclus</i>	4
5. Gray marl, slightly indurated at top, which forms a projecting ledge over Nos. 3 and 4. The top is level with the floor of the bridge at the south end.....	5
4. Stiff brown clay with thin partings of marl..	1
3. Gray or yellow marl with obscure fossils; a thin band of brown clay at bottom.....	1.5
2. Hard pinkish-gray limestone with a little glauconite and fragments of <i>Pinna</i> , etc. A few inches at top consists of soft laminated gray marl with abundant <i>Lepidocyclus</i> and <i>Pecten poulsoni</i>	2
1. Gray or cream-colored sandy marl, with flakes of mica and small grains of glauconite. <i>Pecten poulsoni</i> and fragments of other fossils. Thickness seen.....	1.5

The fossil species in the following list were obtained from the Byram marl at this locality:

Station 7372. Road north of the National Cemetery, north of Vicksburg, Miss., beds 8 and 9 of section; C. W. Cooke, collector, May 16, 1915:

- Lepidocyclus supra* (Conrad).
- Archohelia mississippiensis* (Conrad).
- Archohelia vicksburgensis* (Conrad).
- Actaeocina crassiplica* (Conrad).
- Terebra tantula* Conrad.
- Terebra divisura* Conrad.
- Turris* (Pleuroliaria) cochlearis (Conrad).
- Bathytoma congesta* (Conrad).

- Surcula* (Pleurofusua) vicksburgensis (Conrad).
- Cochlespira cristata* (Conrad).
- Drillia abundans* (Conrad).
- Drillia tantula* (Conrad).
- Scobinella caelata* Conrad.
- Conus protractus* Meyer.
- Conus alveatus* Conrad.
- Olivella mississippiensis* (Conrad).
- Olivella affluens* Casey.
- Caricella demissa* Conrad.
- Lyria mississippiensis* (Conrad).
- Busycon spiniger* (Conrad).
- Latirus protractus* (Conrad).
- Xancus wilsoni* (Conrad).
- Phos mississippiensis* (Conrad).
- Rapana* n. sp. (O. B. Hopkins, collector).
- Murex mississippiensis* Conrad.
- Galeodea* (Sconsia) *lintea* (Conrad).
- Ficus mississippiensis* Conrad.
- Aporrhais lirata* (Conrad).
- Architectonica trilirata* (Conrad).
- Sinum mississippiense* (Conrad).
- Fissuridea mississippiensis* (Conrad).
- Dentalium mississippiense* Conrad.
- Scapharca lesueuri* Dall.
- Ostrea vicksburgensis* Conrad.
- Pecten poulsoni* Morton.
- Corbula engonata* Conrad.
- Protocardia diversa* (Conrad).
- Pitaria* (Lamelliconcha) *imitabilis* (Conrad).
- Macrocallista* (Chionella) *sobrina* (Conrad).
- Crassatellites mississippiensis* (Conrad).

Less complete exposures of the Byram marl are found in the upper courses of both Mint Spring Bayou and Glass Bayou at Vicksburg. At Haynes Bluff, 14 miles north of Vicksburg, only 8½ feet of the Byram marl is exposed. It consists of yellow glauconitic sandy fossiliferous marl overlain by gray calcareous clay. The fossils obtained at Haynes Bluff are listed under station 7385.

BYRAM.

In the bank of Pearl River at Byram are the typical exposures of the Byram marl. Broad ledges of indurated glauconitic marl alternating with softer beds of green clay rise about 10 feet above low-water mark. The rock is abundantly fossiliferous, and most of the fossils are contained in pockets of softer marl. The species which have been obtained from these beds are included in the general list.

The marl beds and ledges of impure limestone extend up and down the river from Byram for several miles, but the individual exposures show thicknesses so small that it is difficult to determine just where to draw the line between the Byram marl and the Marianna limestone.

LEAF RIVER.

On Leaf River the Byram marl appears on the west bank at a fish trap half a mile below the bridge on the Taylorsville-Silvarena road near old Blakeney post office. The strata exposed consist of only 2½ feet of bluish lignitic clay and fossiliferous blue sand, which form a shelf-like bench near water level, but the sands have yielded the large and characteristic fauna which is listed under stations 5615 and 7376.

WOODWARDS.

On Chickasawhay River at Woodward's, 2 miles northwest of Waynesboro, about 5 feet of blue or gray glauconitic shell marl composed largely of Foraminifera and containing an irregularly indurated ledge of gray limestone is exposed beneath the bridge. The deposit evidently forms part of the Byram marl and is probably very near the horizon of the shell bed on Leaf River near Blakeney, which it resembles. In addition to many Foraminifera, including *Lepidocyclina supera* (Conrad), which is characteristic of the Byram marl, the following species have been collected:

Station 6648. Chickasawhay River at wagon bridge one-fourth mile west of Woodward's station, Wayne County, Miss., C. Wythe Cooke, collector:

- Bryozoa (25 species representing 19 genera).
- Lunatia sp.
- Dentalium mississippiense Conrad.
- Scapharca lesueuri Dall.
- Ostrea vicksburgensis Conrad.
- Pecten poulsoni Morton.
- Macrocallista sp.

FAUNA OF THE BYRAM CALCAREOUS MARL.

The following list includes only the corals, mollusks, and echinoderms which are in the principal collections of the U. S. National Museum from the Byram marl. The corals were named by T. W. Vaughan. I identified the mollusks and echinoderms and prepared the lists. The list includes 5 corals, 134 mollusks, and 2 echinoderms, of which 80 occur also in the Mint Spring marl, 46 persisted from the Red Bluff clay (including 6 which have not been found in the Mint Spring marl), and 54 appear to be peculiar to the By-

ram marl. One of the most abundant and most widely distributed species is the little *Scapharca lesueuri* Dall, which appears to be restricted to this horizon. The recent discovery at Vicksburg of a coral which Vaughan reports from the coral reef at Bainbridge, Ga., from Tampa, Fla., and from many places in the West Indies suggests a closer relation of the Oligocene chert of Flint River to the Byram marl than had hitherto been suspected.

In addition to the corals, mollusks, and echinoderms listed here, the accompanying paper by Mr. Cushman adds to the fauna of the Byram marl 68 species and varieties of Foraminifera from Byram alone, and it is certain that study of all the material from other localities now in his hands will add greatly to this number. A monograph by Canu and Bassler⁷ adds 45 Bryozoa to the fauna of the Byram marl.

Stations of the Byram marl.

3722. Vicksburg, Miss. Bluff just above second sawmill on the river. Horizon No. 2 from top. T. W. Vaughan, collector, 1900.

3724. Vicksburg, Miss. Horizon above waterfall on Mint Spring Bayou, near National Cemetery. T. W. Vaughan, collector, 1900.

3729. Vicksburg, Miss. Top of bluff opposite second sawmill, slightly above second horizon. T. W. Vaughan, collector, 1900.

5615. West bank of Leaf River three-quarters of a mile southeast of Blakeney, Smith County, Miss. No. 2 of section. Nearest town is Taylorsville, which is about 8 miles south of Blakeney. G. C. Matson, collector, 1910.

5623. Byram, Hinds County, Miss. West bank of Pearl River. Includes all fossiliferous beds of section. G. C. Matson, collector, 1910.

6449. Confederate Avenue, Vicksburg, Miss., 600 to 700 feet north of bridge over Glass Bayou. C. W. Cooke, collector, Oct. 17, 1912.

6454. Pearl River just above bridge at Byram, Miss. C. W. Cooke, collector, Oct. 23, 1912.

6455. Pearl River at bridge at Byram, Miss. E. N. Lowe, collector, September, 1912.

7376. Leaf River, Smith County, Miss., half a mile below the wagon bridge on Taylorsville-Silvarena road, near old Blakeney post office (same locality as 5615). E. N. Lowe and C. W. Cooke, collectors, May 22, 1915.

7385. Haynes Bluff, Warren County, Miss. Upper marl bed. C. W. Cooke, collector, May 17, 1915.

⁷ Canu, Ferdinand, and Bassler, R. S., North American early Tertiary Bryozoa: U. S. Nat. Mus. Bull. 106, 1920.

Species of corals, mollusks, and echinoderms from the Byram calcareous marl—Continued.

	Byram marl.										Mint Spring marl.	Red Bluff clay.
	Haynes Bluff.	Vicksburg.				Byram.		Leaf River.				
	7385	3722	3724	3729	6449	5623	6454	6455	5615	7376		
Macrocallista (<i>Chionella</i>) <i>sobrina</i> (Conrad).....	×	✓	×	✓	✓						✓	✓
Macrocallista sp.....									×			
Pitaria <i>imitabilis</i> (Conrad).....	✓	✓	×	×		✓	✓	✓			✓	
Pitaria <i>astartiformis</i> (Conrad).....		✓		×								
Pitaria <i>floridana</i> Dall.....												
Chione <i>victoria</i> Dall.....				×								
Chione sp.....			×									
Chione sp.....												
Cardium <i>vicksburgense</i> Conrad ?.....												
Cardium <i>glebosum</i> Conrad.....												
Protocardia <i>diversa</i> (Conrad).....		✓	✓	✓		✓	✓	✓	✓	✓		
Lucina <i>mississippiensis</i> Conrad.....			✓								✓	
Myrtaea sp.....												
Phacoides (Here) cf. <i>P. wacissana</i> Dall.....							✓	✓				
Crassatellites <i>mississippiensis</i> (Conrad).....	✓	✓				✓	✓	✓	✓	✓		
Crassinella sp.....								✓	✓			
Astarte cf. <i>A. triangulata</i> Meyer.....	✓							✓				
Astarte sp.....								✓				
Verticordia <i>dalliana</i> Aldrich.....	✓							✓	✓			✓
Clypeaster <i>rogersi</i> (Morton)?.....						✓	✓	✓			✓	
Schizaster? sp.....							✓	✓				

The following list enumerates the species of Bryozoa which have been recorded by Canu and Bassler¹ from the Byram marl in Mississippi. The initials B and W indicate that the species so marked occur at Byram and Woodwards, respectively. Those marked V are from Vicksburg, but whether from the Byram marl or from the Mint Spring marl is not recorded. Material from both horizons was studied by Canu and Bassler. The letters R, C, and J signify that the species so marked occur also in deposits of Red Bluff, Claiborne, or Jackson age.

- V *Conopeum concavum* Canu and Bassler.
- JB *Hinksina ocalensis* Canu and Bassler.
- V *Membrendoecium lowei* Canu and Bassler.
- V *Membraniporida similis* Canu and Bassler.
- W *Stamenocella inferaviculifera* Canu and Bassler.
- W *Stamenocella grandis* Canu and Bassler.
- W *Scrupocellaria cookei* Canu and Bassler.
- W *Scrupocellaria williardi* Canu and Bassler.
- W *Scrupocellaria clausa* Canu and Bassler.
- VBW *Nellia oculata* Busk.
- JB *Nellia bifaciata* Canu and Bassler.
- B *Diplopholeos lineatum* Canu and Bassler.
- JB *Floridina antiqua* Smitt.

- RVBW *Lunularia (Oligotresium) vicksburgensis* Conrad.
- VW *Lunularia tintinabula* Canu and Bassler.
- JB *Puellina radiata anaticula* Canu and Bassler.
- B *Gephyrotes spectabilis* Canu and Bassler.
- BW *Arachnopusia vicksburgica* Canu and Bassler.
- BW *Trypostega venusta* Norman.
- JB *Hippoporina lucens* Canu and Bassler.
- JW *Hippomenella crassicolis* Canu and Bassler.
- RB *Hippodiplosia baccata* Canu and Bassler.
- VB *Hippodiplosia strangulata* Canu and Bassler.
- BW *Enoplostomella synthetica* Canu and Bassler.
- B *Enoplostomella magniporosa* Canu and Bassler.
- BW *Porella compacta* Canu and Bassler.
- W *Retepora laciniosa* Canu and Bassler.
- VBW *Tubucellaria vicksburgica* Canu and Bassler.
- V *Metrarabdotos moniliferum* Edwards and Haime.
- W *Meniscopora elliptica* Canu and Bassler.
- RB *Adeonellopsis galeata* Canu and Bassler.
- B *Adeonellopsis cyclops* Canu and Bassler.
- B *Perigastrella plana* Canu and Bassler.
- V *Osthimosia glomerata* Gabb and Horn.
- B *Holoporella peristomaria* Canu and Bassler.
- W *Fedora pusilla* Canu and Bassler.
- BW *Oncousoecia quinqueseriata* Canu and Bassler.
- W *Mecynoecia semota* Canu and Bassler.
- W *Exochoecia rugosa* Canu and Bassler.
- W *Diaperoecia clara* Canu and Bassler.
- CJW *Pleuronea subpertusa* Canu and Bassler.
- V *Pleuronea fenestrata* Busk.
- JW *Idmonea milneana* D'Orbigny.
- JW *Idmonea petri* D'Archiac.
- W *Idmonea triforata* Canu.

¹ Canu, Ferdinand, and Bassler, R. S., North American early Tertiary Bryozoa: U. S. Nat. Mus. Bull. 106, pp. 34-38, 1920.

THE FORAMINIFERA OF THE BYRAM CALCAREOUS MARL AT BYRAM, MISSISSIPPI.

By JOSEPH A. CUSHMAN.

INTRODUCTION.

The lower Oligocene of the southeastern Coastal Plain of the United States is in Mississippi divisible into several distinct members. Farther east these divisions are not so clearly distinguishable. Of the divisions in Mississippi the Byram calcareous marl is the youngest. The type section for the Byram marl is an exposure at the bridge over Pearl River at Byram, Hinds County, Miss. The formation is mainly a sandy glauconitic marl with thin beds of impure limestone, clay and sand.

Small lots of the marl from the type section, United States Geological Survey station 6455, collected by E. N. Lowe in 1912, were examined after careful washing. Although but a few cubic centimeters of the original material was taken it has given 68 species and varieties of Foraminifera. More species will probably be added by a further search of the material, but it is probable that all the common species are described in this paper. An examination of the Byram marl from other localities will undoubtedly greatly increase the fauna, but it is very desirable in close stratigraphic studies to have the type section very definitely worked up for comparison with sections in other areas, and in this paper it has been the aim to furnish data for such comparisons.

RELATIONSHIPS OF THE BYRAM FAUNA.

Of the 68 species and varieties which are here recorded from the type section of the Byram calcareous marl, 28 appear to have been previously undescribed, and 8 of these are recorded under the genus only, as the available material was not abundant enough to warrant specific determination. This statement may be compared with the data given in the accompanying paper by Cooke, who lists 134 species of mollusks, 5 corals, and 2 echinoderms, 54 of which are peculiar to the marl at Byram.

One of the most interesting features disclosed in the study of the Foraminifera of this collection has been their relationships with other faunas. The different species are very definitely related both to the fossil Foraminifera so far known from the Atlantic and Gulf Coastal Plain of the United States and to the living Foraminifera of certain regions, especially the Indo-Pacific.

By far the larger proportion of the species and varieties are identical with or closely related to species now living in the Indo-Pacific. Such species as *Textularia folium* Parker and Jones, *Bolivina amygdalaeformis* H. B. Brady, *Bolivina nitida* H. B. Brady, and *Hauerina fragilissima* H. B. Brady are now living in the Indo-Pacific region but are not recorded elsewhere nor have they been previously recognized in the fossil form. They show rather conclusively that there is a very close relationship between the fossil fauna at Byram and the living fauna of the Indo-Pacific.

Of the species here described as new there are several that are also clearly related to the living Indo-Pacific fauna. For example, *Discorbis byramensis* Cushman, n. sp., is nearest in its affinities to *D. corrugata* Millett, described from specimens collected in the Malay Archipelago and recorded by Heron-Allen and Earland from the Kerimba Archipelago, off the southeastern coast of Africa, from the coast of Burma, and from West Australia, thus having a wide Indo-Pacific range. In the characters of its ventral surface *D. byramensis* Cushman is also related to *D. patelliformis* H. B. Brady and *D. tabernacularis* H. B. Brady, both typical Indo-Pacific species. The Byram species is then a fossil representative of a small well-distinguished group of species, the others of which are now living in the Indo-Pacific.

Polymorphina regina H. B. Brady, Parker, and Jones also shows a definite faunal relation. As a recent species it is known from the shallow

waters of the tropical and subtropical parts of the Pacific and Indian oceans. As a fossil it is also known from the Miocene of the Coastal Plain of the United States, from the Calvert formation of Chesapeake Beach, Md., and from the Duplin marl of Mayesville, S. C. This form thus represents a group which lived in this region in early Oligocene time and persisted into the Miocene but then apparently died out here, though it continued in the Indo-Pacific region, to which it may have migrated during the Oligocene.

Certain other species, such as *Truncatulina byramensis* Cushman, n. sp., are evidently characteristic of the Miocene and may not have persisted later than that time. *Truncatulina byramensis* is closely related to *T. basiloba* Cushman and *T. concentrica* Cushman, from the Miocene of South Carolina and Florida.

Lepidocyclina supera (Conrad) is characteristic of a group which so far as known is limited to this horizon and not known elsewhere. *L. supera* seems to be an index fossil of the Byram marl.

RELATION OF BYRAM FAUNA TO FAUNAS OF OTHER LOWER OLIGOCENE FORMATIONS.

The foraminiferal faunas of the other divisions of the lower Oligocene have not been thoroughly studied except at the type stations. Evidence is therefore incomplete as to the definite relationships of the several faunas. Enough is known, however, to show that a number of the species of the Byram marl are found also in the Mint Spring marl and a lesser number in the Red Bluff clay, both of which lie below the Byram marl in Mississippi. Some of these species are also found in the Marianna limestone of Alabama and Florida, but the ecologic conditions of Florida and Mississippi in early Oligocene time were evidently very different, and that alone would account for a considerable difference in the faunas.

ECOLOGIC CONDITIONS UNDER WHICH THE BYRAM MARL WAS DEPOSITED.

From a comparison of the records for those species which are found fossil in the marl at Byram and also living in the Indo-Pacific region it is evident that the Byram marl was deposited in comparatively shallow water (10 to 25 fathoms). As nearly all these species occur in the tropical and subtropical waters of the Indo-Pacific, it would seem that the water at Byram must have had at least subtropical temperature (between 20° and 24° C.). As the

Miocene climate was evidently colder, especially along the Atlantic coast, this alone is probably sufficient reason for the extinction of those species which persisted in the general region until that time.

SPECIES INCLUDED.

Figures are given of most of the species here described. A close study of the material has shown how little is the variation of any particular species in this marl, and it may be questioned whether I am right in the specific references of certain forms, such as those of *Polymorphina*. However, until a comparative study of recent and fossil material can be made they may best be left as at present. It will undoubtedly become possible at some future time to distinguish the fossil species of our Coastal Plain and to divide them much more closely and definitely.

Something of the known distribution of the species is given as well as full descriptions. A list of the species is given below and is followed by the systematic presentation of the fauna.

Textulariidae:

- Textularia agglutinans* D'Orbigny.
- Textularia tumidulum* Cushman, n. sp.
- Textularia subhauerii* Cushman, n. sp.
- Textularia mississippiensis* Cushman, n. sp.
- Textularia folium* Parker and Jones.
- Bolivina amygdalaeformis* H. B. Brady.
- Bolivina nitida* H. B. Brady.
- Bolivina robusta* H. B. Brady.
- Bolivina mississippiensis* Cushman, n. sp.
- Verneuilina spinulosa* Reuss var. *glabrata* Cushman, n. var.
- Clavulina byramensis* Cushman, n. sp.
- Virgulina* sp.
- Bulimina ovata* D'Orbigny?
- Ehrenbergina glabrata* Cushman, n. sp.

Lagenidae:

- Nodosaria* sp.
- Nodosaria* sp.?
- Cristellaria* sp.
- Vaginulina legumen* (Linnaeus) D'Orbigny var. *elegans* D'Orbigny?
- Polymorphina gibba* D'Orbigny.
- Polymorphina gibba* D'Orbigny, fistulose form.
- Polymorphina regina* H. B. Brady, Parker, and Jones.
- Polymorphina byramensis* Cushman, n. sp.
- Polymorphina problema* D'Orbigny?
- Polymorphina amygdaloides* (Reuss) Reuss.
- Uvigerina byramensis* Cushman, n. sp.

Globigerinidae:

- Globigerina bulloides* D'Orbigny.
- Globigerina triloba* Reuss.

Rotalliidae:

- Spirillina subdecorata* Cushman, n. sp.
- Discorbis byramensis* Cushman, n. sp.
- Discorbis orbicularis* (Terquem) Berthelin.

Rotaliidae—Continued.

- Truncatulina lobatula* (Walker and Jacob) D'Orbigny.
Truncatulina byramensis Cushman, n. sp.
Truncatulina americana Cushman.
Truncatulina pseudoungeriana Cushman, n. sp.
Anomalina bilateralis Cushman, n. sp.
Anomalina grosserugosa (Gümbel) H. B. Brady? var.
Anomalina mississippiensis Cushman, n. sp.
Siphonina advena Cushman, n. sp.
Gypsina rubra (D'Orbigny) Heron-Allen and Earland.
Pulvinulina byramensis Cushman, n. sp.
Pulvinulina advena Cushman, n. sp.
Pulvinulina glabrata Cushman, n. sp.
Rotalia byramensis Cushman, n. sp.
Rotalia dentata Parker and Jones.
Asterigerina subacuta Cushman, n. sp.

Nummulitidae:

- Nonionina umbilicatulata* (Montagu) Parker, Jones, and H. B. Brady.
Nonionina scapha (Fichtel and Moll) Parker and Jones.
Nummulites sp.
Lepidocyclina supera (Conrad) H. Douvillé.

Miliolidae:

- Cornuspira involvens* (Reuss) Reuss.
Spiroloculina grateloupi D'Orbigny.
Spiroloculina byramensis Cushman, n. sp.
Spiroloculina imprimata Cushman, n. sp.
Vertebralina advena Cushman, n. sp.
Vertebralina sp.?
Quinqueloculina crassa D'Orbigny?
Quinqueloculina bicostata D'Orbigny, var.
Quinqueloculina cuvieriana D'Orbigny.
Quinqueloculina venusta Karrer?, var.
Quinqueloculina sp.?
Hauerina fragilissima (H. B. Brady) Millett.
Hauerina sp.?
Articulina byramensis Cushman, n. sp.
Massilina crusta Cushman, n. sp.
Massilina oclusa Cushman, n. sp.
Massilina oclusa Cushman, n. sp., var. *costulata* Cushman, n. var.
Triloculina rotunda D'Orbigny.
Triloculina oblonga (Montagu) D'Orbigny.
Triloculina trigonula (Lamarek) D'Orbigny.
Biloculina sp.?

DESCRIPTIONS.

Family **TEXTULARIIDAE.**Genus **TEXTULARIA** DeFrance, 1824.***Textularia agglutinans* D'Orbigny.**

Plate XIV, figures 1a, 1b.

- Textularia agglutinans* D'Orbigny, in De la Sagra, Histoire physique, politique et naturelle de l'île de Cuba, Foraminifères, p. 136, pl. 1, figs. 17, 18, 32-34, 1839.
H. B. Brady, *Challenger* Rept., Zoology, vol. 9, p. 363, pl. 43, figs. 1, 2, 1884.
Cushman, U. S. Nat. Mus. Bull. 71, pt. 2, p. 9, figs. 10a, b (in text), 1911.

Test elongate, large and stout, gradually tapering from the initial end, chambers nearly as high as wide, tumid; sutures depressed, dis-

tinged, early portion somewhat compressed; wall coarsely arenaceous, but in section with a calcareous base; aperture in a well-marked depression at the base of the inner margin of the last-formed chamber; early chambers usually rougher than the later ones. Length 2 millimeters or less.

Textularia agglutinans is rather common in the Byram marl. The specimens are closely similar to the types from Cuba described by D'Orbigny.

This name has been used for a great variety of forms, but it should be limited to the one described by D'Orbigny, which has a generally tapering form and very rounded chambers, with the surface arenaceous but rather smoothly finished.

***Textularia tumidulum* Cushman, n. sp.**

Plate XV, figures 1, 2a, 2b.

Test large, elongate, compressed, thickest in the central region, thence thinning toward the periphery, initial end rapidly broadening in the adult, the sides nearly parallel to a point near the apertural end, where the breadth of the test is reduced; chambers numerous, in the adult about three times as wide as high, and the last-formed chamber in many old-age specimens somewhat distinctly set off from the others, the inner portion of each chamber much thicker than the other portions and in the rapid decrease in thickness often leaving a channel running lengthwise of the test between this central tumid area and the gradually sloping outer portion, usually very well marked in adult specimens; sutures not very distinct; wall arenaceous but smoothly finished. Largest specimens 2.5 millimeters in length.

This is one of the most common and most conspicuous of the species of the Byram marl at Byram. It is very well characterized by its central tumid area with longitudinal channels at each side, and the general slope to the rounded periphery. The figures show a typical adult (except that the sutures are more distinct than is typical) and a specimen in its earlier stage before the tumid central portions are so strongly developed.

***Textularia subhauerii* Cushman, n. sp.**

Plate XIV, figures 2a, 2b.

Test large, stout, elongate, early portion rapidly increasing in width with each newly added chamber, later adult portion with the

sides nearly parallel, slightly lobulated; periphery rounded but the median portion nearly flat; chambers eighteen to twenty, increasing in height as added, those of the later portion nearly as high as broad, sutures usually rather indistinct; wall coarsely arenaceous but smoothly finished on the exterior; aperture at the base of the inner margin of the chamber. Length 2 millimeters or less.

This species is represented by a few specimens from the Byram marl of rather uniform size and general character.

Heron-Allen and Earland¹ figure a *Textularia* from the Kerimba Archipelago, off the southeastern coast of Africa, which they refer to *T. hauerii* D'Orbigny. In some of its characters our Byram marl species resembles this. A similar form from the Philippines I have referred to *T. hauerii*. A study of D'Orbigny's *T. hauerii* from the Vienna Basin, however, shows that it is very different from the Byram species and apparently also different from the Philippine and Kerimba species.

***Textularia mississippiensis* Cushman, n. sp.**

Plate XIV, figure 4.

Test elongate, fairly broad, thickest in the middle, thence thinning toward the periphery, in end view biconvex, central portion curved; chambers rather low and broad, especially in the early stages, becoming higher in the adult and often less broad so that the later chambers in the adult make a test less wide than at earlier stages; sutures covered by a coarsely arenaceous layer meeting in the center and at the periphery, leaving the central portion of each chamber uncovered, periphery irregular, not definitely or regularly spinose; chamber walls smooth and finely perforate. Length 0.40 to 0.55 millimeter.

This is a common small species in the Byram marl. It is in general character very uniform in the material studied and also very constant in size. In some of its features it resembles *T. pseudocarinata* Cushman (*T. carinata* H. B. Brady; not *T. carinata* D'Orbigny), but it is much smaller and lacks the strongly rhomboidal shape in end view, and the carinae and especially the spines are not so definitely developed. *T. pseudocarinata* is especially characteristic of the Philippine region. The Byram species also resembles very much the form I

have described as *T. sagittula* var. *atrata*,² which came from the eastern channel of Korea Strait, in 59 fathoms.

***Textularia folium* Parker and Jones.**

Plate XIV, figure 3.

- Textularia folium* Parker and Jones, Roy. Soc. Philos. Trans., vol. 155, pp. 370, 420, pl. 18, fig. 19, 1865.
 Moebius, Beiträge zur Meeresfauna der Insel Mauritius, p. 92, pl. 8, figs. 16, 17, 1880.
 H. B. Brady, *Challenger* Rept., Zoology, vol. 9, p. 357, pl. 42, figs. 1-5, 1884.
 Egger, K. Bayer Akad. Wiss. München Abh., Cl. 2, vol. 18, p. 272, pl. 6, figs. 27, 28, 1893.
 Chapman, Linnean Soc. London Jour. (Zoology), vol. 28, p. 184, 1900 [1902]; Quckett Micr. Club Jour., 2d ser., vol. 10, p. 127, pl. 9, fig. 4, 1907 [1909].
 Rumbler, Zool. Jahrb., Abt. Syst., vol. 24, p. 59, pl. 5, figs. 51, 52, 1906.
 Bagg, U. S. Nat. Mus. Proc., vol. 34, p. 130, 1908.
 Cushman, U. S. Nat. Mus. Bull. 71, pt. 2, p. 19, figs. 31-33 (in text), 1911.
 Heron-Allen and Earland, Zool. Soc. London Trans., vol. 20, p. 623, 1915.

Test small, very much flattened, broad, in front view triangular, in edge view narrow, tapering toward the acute margins; chambers, especially in later development, broad and low, somewhat recurved, the inner and distal margins thickened, prolonged at the periphery into short backward-pointing spinose processes, smooth; wall fairly thick. Length not usually exceeding 0.5 millimeter.

This species is rare in the Byram marl at Byram (U. S. G. S. station 6455). The only difference between this and living specimens lies in its more regular development of spinose projections. It is very interesting, however, in showing the relationship of the Byram marl fauna to existing faunas. At the present time the species seems to be confined to the Indo-Pacific region and is more abundant in the south Pacific than elsewhere. It is known from rare specimens obtained in Mauritius (Moebius) and in the Kerimba Archipelago, off southeastern Africa (Heron-Allen and Earland). It was originally described from specimens collected in the shore sands of Melbourne, Australia, by Parker and Jones. H. B. Brady gives the following localities in the *Challenger* report: Off East Moncoeur Island, Bass Strait, 38 fathoms; off Raine Island, Torres Strait, 155 fathoms; off Kandavu, Fiji, 255 fathoms; off Levuka, Fiji; Nares Harbor, Admiralty Islands, 17 fathoms; Honolulu coral reefs,

¹ Zool. Soc. London Trans., vol. 20, p. 628, pl. 47, figs. 21-23, 1915.

² U. S. Nat. Mus. Bull. 71, pt. 2, p. 7, figs. 2-5 (in text), 1911.

40 fathoms. It has also been found in the lagoon of Funafuti and off the coast of Victoria (Chapman); off Laysan (Rhumbler); and at several localities off the Hawaiian Islands (Bagg, Cushman).

Most of the recorded specimens of the species were obtained in 40 fathoms or less, although off Fiji it was found at a depth of 255 fathoms, and off the Hawaiian Islands at 249 to 305 fathoms. It is evidently most abundant on tropical coral reefs of the south Pacific.

Genus BOLIVINA D'Orbigny, 1839.

***Bolivina amygdalaeformis* H. B. Brady.**

Plate XV, figure 3.

Bolivina amygdalaeformis H. B. Brady, Quart. Jour. Micr. Sci., vol. 21, p. 59, 1881; *Challenger* Rept., Zoology, vol. 9, p. 426, pl. 53, figs. 28, 29, 1884.
Cushman, U. S. Nat. Mus. Bull. 71, pt. 2, p. 42, figs. 69a, b (in text), 1911.

Test elongate, somewhat fusiform, thickest in the middle, periphery well rounded, chambers comparatively few; sutures hidden by the ornamentation of the surface, consisting of numerous longitudinal irregularly anastomosing costae; the last-formed chambers lacking the costae but with numerous large depressions; aperture terminal, elongate-oval, somewhat constricted near the middle. Length 0.80 millimeter or less.

This species is rare in the Byram marl, yet it is very distinct. In its recent distribution it is decidedly a Pacific form. It was originally described by Brady from specimens obtained off the Philippines at 95 fathoms, off the Admiralty Islands at 16 to 25 fathoms, off the north coast of New Guinea at 1,070 fathoms, and in Torres Strait at 155 fathoms. I have recorded specimens from two *Albatross* stations—D4875, in 59 fathoms, eastern channel of Korea Strait, and D4964, in 37 fathoms, off the southern coast of Japan.

This is one of the species which shows the relation of the Byram marl fauna to the existing fauna of the south Pacific, Australian, East Indian, and Philippine regions.

***Bolivina nitida* H. B. Brady.**

Plate XV, figure 4.

Bolivina nitida H. B. Brady, *Challenger* Rept., Zoology, vol. 9, p. 420, pl. 52, figs. 30a, b, 1884.
Bolivina laevigata H. B. Brady (not *B. laevigata* D'Orbigny), Quart. Jour. Micr. Sci., vol. 21, p. 57, 1881.

Test elongate, thin, complanate, broadest at the center, tapering and rounded toward the ends. Segments few

in number, regularly textularian in arrangement; broad, flattened on both faces, and bordered both at sutures and periphery by a narrow band of clear shell substance. Sutures even; aperture large, irregularly oval, oblique. Length 1/60th inch (0.42 millimeter).

The above description, quoted from the *Challenger* report, is very accurate for the species as found in the Byram marl. The specimen figured here is one of the most extreme, the majority of the specimens being very close to the figure given by Brady. The large oblique aperture and the flattened test, carinate, with the carinae continued between and separating the chambers, are distinguishing characters.

Brady's material came from two *Challenger* stations off Australia—off East Monocour Island, Bass Strait, at 38 fathoms, and off Raine Island, Torres Strait, at 155 fathoms. The species was rare at both these stations, and the lack of records elsewhere seems to show that it is either local or rare. Its occurrence in the Byram marl is therefore decidedly interesting.

***Bolivina robusta* H. B. Brady.**

Bolivina robusta H. B. Brady, Quart. Jour. Micr. Sci., vol. 21, p. 57, 1881; *Challenger* Rept., Zoology, vol. 9, p. 421, pl. 53, figs. 7-9, 1884.
Egger, K. bayer. Akad. Wiss. München Abh., (1. 2, vol. 18, p. 294, pl. 8, figs. 31, 32, 1893.
Millett, Roy. Micr. Soc. Jour., p. 543, 1900.
Cushman, U. S. Nat. Mus. Bull. 71, pt. 2, p. 36, figs. 59, 60 (in text), 1911.
Heron-Allen and Earland, Zool. Soc. London Trans., vol. 20, p. 646, 1915.

Test small, in front view rhomboid, thickest along the median line, thence gradually sloping to the sides; chambers numerous, usually much lower than wide, slightly tumid, especially in the last-formed portion, sutures distinct, curved, slightly depressed, in the later chambers often with the posterior side of the chamber crenulate with numerous reentrants; wall with numerous rather coarse perforations. Length usually less than 0.5 millimeter.

Small specimens of this species are common in the Byram marl material examined. None of the specimens have the stout apical spine which appears in at least one form of the species in its living form.

There is probably more than one form or variety of this species in recent seas. Most of the specimens recorded by Brady were found in the Pacific, especially the south Pacific. Later records add numerous stations from the Pacific, and Heron-Allen and Earland record it

from the western part of the Indian Ocean, off the coast of Africa. In spite of other records the typical form of the species occurs mainly in the Indo-Pacific region.

***Bolivina mississippiensis* Cushman, n. sp.**

Plate XV, figure 5.

Test elongate, slender, gradually tapering from the subacute initial end to the broadly rounded apertural end; thickest in the median line; chambers numerous, wider than high, curved, sutures marked by limbate lines, broadly curved and somewhat broken near the inner end, not depressed; surface of test smooth and even. Length about 0.4 millimeter.

This species is rare in the Byram marl. It may be distinguished by the narrow, tapering form, the peculiarly marked sutures, and the very even smooth surface.

Genus VERNEUILINA D'Orbigny, 1840.

***Verneuilina spinulosa* Reuss var. *glabrata* Cushman, n. var.**

Test pyramidal, three-sided, widest above the middle, generally triangular in transverse section, the sides somewhat concave; angles of the test bluntly angled or even rounded, without spines; surface smooth; aperture small, at the inner side of the last-formed chamber. Length 0.75 millimeter or less.

This variety of the species is fairly common in the typical Byram marl. It differs from the typical form of the species in its lack of spines, the edges often being rounded and thickened. No specimens approaching the typical form were found.

The species is very characteristic of shallow tropical and subtropical waters of the Indo-Pacific region.

Genus CLAVULINA D'Orbigny, 1826.

***Clavulina byramensis* Cushman, n. sp.**

Plate XVI, figure 1.

Test elongate, subcylindrical, the early chambers triserial, forming but a small portion of the test; later ones uniserial, both portions rounded; sutures slightly depressed, often not very distinct otherwise; aperture terminal, central, rounded; wall coarsely arenaceous but smoothly finished. Length 2 millimeters or less.

This form is very common in the Byram marl and one of the characteristic species.

The early portion is small in proportion to the whole test and consists of a considerable number of rounded chambers in a triserial arrangement, but the resulting mass with rounded angles forms a bulbous tip to the otherwise tapering test. The sutures of this early portion are usually very indistinct.

This resembles certain tropical Pacific species and probably has its affinities in that region. It is quite likely that Pacific forms which have been referred by authors to *C. parisiensis* D'Orbigny are closer to this species.

Genus VIRGULINA D'Orbigny, 1826.

***Virgulina* sp.**

Plate XVI, figures 2a, 2b, 3.

A rare species in the marl at Byram is figured. It is much compressed, the later chambers resembling those of *Bolivina* in being elongate and curved. The surface is smooth, and in some of its characters this form resembles *V. subsquamosa* Egger, but it does not have the curved axis of that species. Certain specimens from the Indo-Pacific region suggest this form from Byram. Some of the figures of the Kerimba Archipelago material which Heron-Allen and Earland³ assign to *V. schreibersiana* Czjzek are very similar to this. They note that the typical form is very rare and then say: "The form generally assumed throughout the gatherings is a broad-mouthed, somewhat compressed but regular-chambered type, varying greatly in proportionate length and breadth." Our specimens in certain respects resemble this form.

Genus BULIMINA D'Orbigny, 1826.

***Bulimina ovata* D'Orbigny?**

Plate XVI, figure 4.

Bulimina ovata D'Orbigny. Foraminifères fossiles du bassin tertiaire de Vienne, p. 185, pl. 11, figs. 13, 14, 1846.

H. B. Brady. *Challenger* Rept., Zoology, vol 9, p. 400, pl. 50, figs. 13a, b, 1884.

This species is very rare in the Byram marl, and the correctness of the identification is very questionable. The specimen figured is elongate, oval, and has a smooth surface and somewhat elongate chambers with fairly depressed sutures.

³ Zool. Soc. London Trans., vol. 20, p. 643, pl. 49, figs. 1-12, 1915.

Genus **EHRENBERGINA** Reuss, 1850.*Ehrenbergina glabrata* Cushman, n. sp.

Plate XVII, figures 4a-4c.

Test small, in front view broadly triangular, chambers numerous, distinct, low and broad, sutures distinct, on the ventral side at the bottoms of deep rounded depressions, on the dorsal side but slightly depressed below the general surface, periphery lobulate; surface smooth, aperture elliptical at the base of the inner margin of the last-formed chamber. Length 0.4 millimeter.

This species is rare in the Byram marl at the type station. It differs from the widely distributed deep-water species *E. serrata* Reuss in the rounded chambers, smooth surface, and lack of spines or sharp angles.

A form that occurs in comparatively shallow water in the Australian region is very similar to the species figured here and may be the same. The identity would not be surprising, in view of the relationships of other species already noted.

Family **LAGENIDAE**.Genus **NODOSARIA** Lamarck, 1812.*Nodosaria* sp.

Plate XVI, figure 5.

A single specimen of *Nodosaria* in the material from the Byram marl is incomplete, showing only the last four chambers. It has a tapering form, well-defined chambers, and the surface ornamented by ten to twelve longitudinal costae. This specimen is here figured but not identified specifically, as the material is not well enough preserved.

Nodosaria sp.?

Plate XVI, figure 6.

The figured specimen shows the characters of a single, fragmentary specimen with both ends missing. It is smaller than the specimen described above but has nearly twice as many costae, and the chambers are not well marked. It can not be identified specifically until more material is available.

Genus **CRISTELLARIA** Lamarck, 1812.*Cristellaria* sp.

A single specimen of the genus *Cristellaria* is included in the Byram marl material exam-

ined from the type locality. It has very few chambers, seven or eight in the visible coil; the surface is generally smooth, except on the sutures, which are marked by rather broad, curved, raised ridges, those near the earlier part of the coil broken into rounded knobs, the later ones more continuous; periphery angled but not carinate, the apertural face smooth and somewhat concave; aperture at the angle of the chamber. Length about 0.65 millimeter.

As this is a unique form its specific assignment should await the finding of more material.

Genus **VAGINULINA** D'Orbigny, 1826.*Vaginulina legumen* (Linnaeus) D'Orbigny var. *elegans* (D'Orbigny) Fornasini.

Plate XVII, figure 1.

A single specimen from the marl at Byram shows the earlier chambers with a fairly well developed spine, the chambers as long as wide, surface smooth, sutures somewhat oblique, and showing a ventral side where the suture runs backward somewhat. This is not unlike certain forms now found living in the Philippine region.

Genus **POLYMORPHINA** D'Orbigny, 1826.*Polymorphina gibba* D'Orbigny.

Plate XVII, figure 3.

Polymorphina subcordiformia vel *oviformia* Soldani, *Testaceographiae*, vol. 1, pt. 2, p. 114, pl. 113, figs. zz, C, etc., 1791.

Polymorphina (Globulina) gibba D'Orbigny, *Annales sci. nat.*, vol. 7, p. 226, No. 20, Modèles, No. 63, 1826.

Egger, *Neues Jahrb.*, 1857, p. 288, pl. 13, figs. 1-4.

Polymorphina gibba H. B. Brady, Parker, and Jones (part), *Linnean Soc. London Trans.*, vol. 27, p. 216, pl. 39, figs. 2a-d, 1870.

H. B. Brady, *Challenger Rept.*, Zoology, vol. 9, p. 561, pl. 71, figs. 12a, b, 1884.

Sidebottom, *Manchester Lit. and Philos. Soc. Mem. and Proc.*, vol. 51, No. 9, p. 10, pl. 2, figs. 15-17, 1907.

Cushman, *U. S. Nat. Mus. Bull.* 71, pt. 3, p. 85, pl. 41, fig. 4, 1913; *U. S. Geol. Survey Bull.* 676, p. 11, pl. 2, fig. 4, p. 52, pl. 11, fig. 5, 1918.

Test rotund, in front view nearly circular, in end view broadly oval; chambers few, distinct, sutures distinct, but little if at all excavated; wall smooth and translucent; aperture slightly produced, radiate. Length 0.75 millimeter or less.

Specimens that seem identical with this species are common in the Byram marl. They have usually not more than three chambers. The earliest one, the proloculum before the later chambers are added, is very similar to *Lagena globosa* in form and could easily be mistaken for it, even the aperture not having clearly developed its radiate character at this stage. Specimens that would be classed as *L. globosa* are found in the Byram marl, but with them are specimens in the two and three chambered stages, showing that they are the young of *Polymorphina gibba*.

This is a widely distributed species, both in recent seas and in the fossil series. I have already recorded it from the Pliocene and Miocene of the Coastal Plain.

***Polymorphina gibba* D'Orbigny, fistulose form.**

Plate XVIII, figures 3a, 3b.

The figured specimen shows a fistulose form which may be referred to *P. gibba*. It has numerous branched, semicylindrical processes, mostly from the last-formed chamber.

***Polymorphina regina* H. B. Brady, Parker, and Jones.**

Plate XVIII, figure 4.

Polymorphina regina H. B. Brady, Parker, and Jones, Linnean Soc. London Trans., vol. 27, p. 241, pl. 41, figs. 32a, b, 1870.

H. B. Brady, *Challenger* Rept., Zoology, vol. 9, p. 571, pl. 73, figs. 11-13, 1884.

Egger, K. Bayer. Akad. Wiss. München Abh., Cl. 2, vol. 18, p. 310, pl. 9, figs. 45, 50, 51, 1893.

Millett, Roy. Micr. Soc. Jour., p. 265, 1903.

Bagg, Maryland Geol. Survey, Miocene, p. 478, pl. 133, fig. 7, 1904; U. S. Nat. Mus. Proc., vol. 34, p. 149, 1908.

Chapman, Quekett Micr. Club Jour., 2d ser., vol. 10, p. 132, pl. 10, fig. 4, 1907 [1909]; Roy. Soc. Victoria Proc., vol. 22, p. 281, 1910.

Cushman, U. S. Nat. Mus. Bull. 71, pt. 3, p. 91, pl. 41, figs. 6, 7, 1913; U. S. Geol. Survey Bull. 676, p. 54, pl. 11, figs. 3, 4, 1918.

Heron-Allen and Earland, Zool. Soc. London Trans., vol. 20, p. 673, 1915.

Test elongate, fusiform; chambers tumid, distinct, especially in the later portion, sutures deep; wall ornamented by numerous longitudinal costae, usually continuing unbroken across several chambers; aperture radiate, somewhat produced. Length 1 millimeter or less.

This species is rare in the Byram marl. It is known from the Miocene of the Coastal Plain in

the Calvert formation of Chesapeake Beach, Md. (Bagg), and the Duplin marl of Mayesville, S. C. (Cushman). It is not known to occur in the Tertiary of Europe but is a typical species in the shallow water of the tropical and subtropical Pacific and Indian oceans.

This is another of the species by which the foraminiferal fauna of the Byram marl is correlated with the living fauna of the Indo-Pacific.

The specimen here figured is a young one with but a few chambers developed, not showing the typical adult form.

***Polymorphina byramensis* Cushman, n. sp.**

Plate XVII, figures 2a, 2b.

Test short and broad, triangular, composed of a few chambers, usually only four, all except a final fifth chamber extending back to the base of the proloculum, forming a truncate test; chambers inflated, sutures deep and distinct; surface smooth; aperture radiate, only slightly produced. Length 0.75 millimeter or less.

This is one of the most common species in the Byram marl. It is characterized by its truncate base and triangular form. It resembles the group of *Polymorphina* represented by *P. trigonula* Reuss. Sidebottom⁴ has figured a specimen which he refers to *P. lactea* but states that it is not typical. It is near this species.

The proloculum alone strongly resembles that of *P. gibba* in being spherical and translucent. Most of the specimens have the three or four chambers with the triangular, truncate test, but a few have a fifth chamber, usually smaller than the rest and near the upper part of the test. This seems to mark the full development of the species.

***Polymorphina problema* D'Orbigny?**

Plate XVIII, figure 1.

Polymorphina (Guttulina) problema D'Orbigny, Annales sci. nat., vol. 7, p. 266, No. 14, Modèles, No. 61, 1826.

Guttulina problema D'Orbigny, Foraminifères fossiles du bassin tertiaire de Vienne, p. 224, pl. 12, figs. 26-28, 1846.

The form of *Polymorphina problema* found in the Byram marl is not unlike that figured by Brady⁵ but is even more like recent specimens

⁴ Manchester Lit. and Philos. Soc. Mem. and Proc., vol. 51, No. 9, p. 9, pl. 2, fig. 11, 1907.

⁵ *Challenger* Rept., Zoology, vol. 9, p. 568, pl. 72, fig. 20; pl. 73, fig. 1, 1884.

from the Philippine region, where this species attains a large size. This is by far the largest of the Byram species but is not so common as some of the others. The truncate apertural end is the usual character in both the fossil and recent material of this form.

Polymorphina amygdaloides (Reuss) Reuss.

Plate XVIII, figures 2a, 2b.

Globulina amygdaloides Reuss, Deutsch. geol. Gesell. Zeitschr., vol. 3, p. 82, pl. 6, fig. 47, 1851.

Polymorphina amygdaloides (Reuss) Reuss, Akad. Wiss. Wien Sitzungsber., vol. 18, p. 250, pl. 8, fig. 84, 1855.

H. B. Brady, *Challenger* Rept., Zoology, vol. 9, p. 560, pl. 71, fig. 13 (?), 1884.

Millett, Roy. Micr. Soc. Jour., p. 261, 1903.

Sidebottom, Manchester Lit. and Philos. Soc. Mem. and Proc., vol. 51, No. 9, p. 9, pl. 2, figs. 12-14, 1907.

Bagg, U. S. Nat. Mus. Proc., vol. 34, p. 148, 1908.

Cushman, U. S. Nat. Mus. Bull. 71, pt. 3, p. 85, pl. 41, fig. 5, 1913.

Test elongate-oval, much compressed, composed of few chambers which are elongate and narrow; sutures rather indistinct, not depressed; surface smooth; aperture somewhat produced. Length 0.65 millimeter or less.

A few compressed, elongate specimens from the Byram marl may best be referred to this species.

An examination of the figures of specimens referred to this species by different authors will show a very considerable range of forms.

Genus UVIGERINA D'Orbigny, 1826.

***Uvigerina byramensis* Cushman, n. sp.**

Plate XVIII, figure 5.

Test minute, elongate, somewhat fusiform, initial end pointed, chambers numerous, distinct, sutures depressed, surface ornamented by longitudinal costae, rather thin and sharp, the last-formed chamber more distinct than the rest, the inner side concave, the other two sides slightly convex, giving a generally triangular section, the surface of this last-formed chamber smooth, the apertural end produced into a short cylindrical neck with a slight lip, the aperture circular. Length 0.25 to 0.35 millimeter.

This species, which is the only one of the genus in the Byram marl at its type locality, is very distinct and constant in its characters. The size is very uniform, and the peculiar shape of the last-formed chamber in the adult is characteristic.

Family GLOBIGERINIDAE.

Genus GLOBIGERINA D'Orbigny, 1826.

***Globigerina bulloides* D'Orbigny.**

Plate XIX, figures 1-3.

Globigerina bulloides D'Orbigny, Annales sci. nat., vol. 7, p. 277, No. 1, Modèles, Nos. 17, 76, 1826; in Barker, Webb, and Berthelot, Histoire naturelle des îles Canaries, pt. 2, Foraminifères, p. 132, pl. 2, figs. 1-3 28, 1839.

H. B. Brady, *Challenger* Rept., Zoology, vol. 9, p. 593, pl. 77; pl. 79, figs. 3-7, 1884.

There are in the typical Byram marl but few specimens of either this species or *G. triloba*, listed below. The specimens referred to *G. bulloides* are very constant in their characters and are of the form shown in the figures given. They are very similar except in their lower spire to the form figured by Brady in the *Challenger* report, plate 79, figure 7. There are but four visible chambers from the ventral side.

***Globigerina triloba* Reuss.**

Globigerina triloba Reuss, Akad. Wiss. Wien Denkschr., vol. 1, p. 374, pl. 47, figs. 11a-e, 1849.

Globigerina bulloides D'Orbigny var. *triloba* H. B. Brady, *Challenger* Rept., Zoology, vol. 9, p. 595, pl. 81, figs. 2, 3, 1884.

Specimens which are very similar to the species described by Reuss and figured by Brady are found rarely in the Byram marl. In all the specimens the three visible chambers make up the whole of the exterior of the test. The walls are very thin and translucent.

Family ROTALIIDAE.

Genus SPIRILLINA Ehrenberg, 1841.

***Spirillina subdecorata* Cushman, n. sp.**

Plate XIX, figures 4, 5.

Test discoidal, much flattened, consisting of eight or more coils, slightly embracing, dorsal side slightly convex, ventral side strongly concave in the middle, chamber broad, the periphery with a broad, thin keel, the main surface of the chamber on the dorsal side granular, ventral side more nearly smooth; aperture at the end of the tube. Diameter about 0.5 millimeter.

Several specimens of this same character were found in the marl at Byram. One of these is attached to a shell fragment by the ventral side.

This species is perhaps nearest in character to *S. decorata* H. B. Brady, an Indo-Pacific species.

Genus **DISCORBIS** Lamarck, 1804.

Discorbis byramensis Cushman, n. sp.

Plate XIX, figures 6-8.

Test pyramidal, low, octagonal, ventral side slightly concave, peripheral margin subacute; eight chambers in each of the four or more coils, their margins uniting to form a series of eight ribs extending radially from the apex of the test to the periphery, the lateral sutures much less distinct, surface between the ridges concave but smooth; ventral surface composed of numerous radiating rounded costae broken up transversely to form a beaded surface; umbilical area hollow; aperture at the base of the last-formed chamber. Diameter 0.35 to 0.40 millimeter, height 0.10 millimeter.

This well-characterized species is very rare in the marl at Byram. It is probably nearest in its affinities to *D. corrugata* Millett, described from specimens obtained in the Malay Archipelago and recorded by Heron-Allen and Earland from the Kerimba Archipelago, off the southeastern coast of Africa. *D. corrugata* seems to have but half as many chambers to a coil as *D. byramensis* and is much higher in proportion. The Kerimba specimens show the sutural lines, but the Malay specimens do not. This species is also recorded by Heron-Allen and Earland from Sandoway, Arakan coast, Burma, and Rottneest Island, West Australia, thus having a wide Indo-Pacific range. In the characters of the ventral surface it is also related to *D. patelliformis* H. B. Brady and *D. tabernacularis* H. B. Brady, both typical Indo-Pacific species.

With the geographic relationships of *D. byramensis* its occurrence in the lower Oligocene of Mississippi is very interesting.

Discorbis orbicularis (Terquem) Berthelin.

Plate XIX, figures 9, 10.

Rosalina orbicularis Terquem, Essai sur le classement des animaux qui vivent sur la plage de Dunkerque, fasc. 2, p. 75, pl. 9, figs. 4a, b, 1870.

Discorbis orbicularis (Terquem) Berthelin, Liste des foraminifères recueillis dans la baie de Borgneuf et à Pornichet, p. 39, No. 63, 1878.

Cushman, U. S. Nat. Mus. Bull. 71, pt. 5, p. 16, pl. 11, fig. 1; figs. 18a-c (in text), 1915.

Discorbina orbicularis (Terquem) H. B. Brady, *Challenger* Rept., Zoology, vol. 9, p. 647, pl. 88, figs. 4-8, 1884 (and numerous subsequent authors).

A few specimens of the broad, flat, scalelike form that is common in shallow water of tropical and subtropical seas were found in the marl

at Byram. They are here referred to *D. orbicularis* Terquem, although the number of chambers is much less than in the usual form of that species. All the specimens are of similar size and character. Diameter 0.55 millimeter or less.

The figures of specimens referred to this species by various authors show a considerable range of form and character.

Genus **TRUNCATULINA** D'Orbigny, 1826.

Truncatulina lobatula (Walker and Jacob) D'Orbigny.

Plate XX, figures 1-3.

"*Nautilus spiralis lobatus*, etc.," Walker and Boys, *Testacea minuta rariora*, p. 20, pl. 3, fig. 71, 1784.

Nautilus lobatula Walker and Jacob, *Adams's Essays on the microscope*, Kanmacher's ed., p. 642, pl. 14, fig. 36, 1798.

Truncatulina lobatula (Walker and Jacob) D'Orbigny, in Barker, Webb, and Berthelot, *Histoire naturelle des îles Canaries*, vol. 2, pt. 2, Foraminifères, p. 134, pl. 2, figs. 22-24, 1839; *Foraminifères fossiles du bassin tertiaire de Vienne*, p. 168, pl. 9, figs. 18-23, 1846.

H. B. Brady, *Challenger* Rept., Zoology, vol. 9, p. 660, pl. 92, fig. 10; pl. 93, fig. 1, 1884.

Specimens of an abundant form in the Byram marl are referred to this species. In most of them the last half of the final whorl is somewhat angled so that a shallow depression is formed on the dorsal surface. The ventral surface is well rounded. This is a very widespread species, but from the appearance of the fossil forms from various horizons it may have more than one form.

It has been recorded from the Pliocene (Waccamaw formation) at Cronly, N. C.,⁶ from several Miocene formations in Maryland, Virginia, South Carolina, and Florida,⁷ and from the Miocene of Santo Domingo.⁸

Truncatulina byramensis Cushman, n. sp.

Plate XX, figures 4-6.

Test planoconvex, dorsal side slightly convex, ventral side flattened, peripheral margin subcarinate; about eight chambers in the last-formed whorl, chambers on the ventral side failing to reach the center of the test, leaving a definite umbilical area which is filled with clear shell material; on the dorsal side each chamber at its inner border has the angles somewhat produced and a broad, rounded reentrant near the middle; on the ventral side the inner half of the chamber is rather in-

⁶ U. S. Geol. Survey Bull. 676, p. 16, pl. 1, fig. 10, 1918.

⁷ *Idem*, p. 60, pl. 17, figs. 1-3.

⁸ Carnegie Inst. Washington Pub. 291, p. 41, 1919.

tricately lobed, the chambers themselves of lighter color, the sutures darker, of clear shell material; surface finely granular; aperture an elongate opening at the base of the last-formed chamber near its inner ventral border. Diameter 0.35 to 0.75 millimeter.

This species is rather common in the marl at Byram. In the form of the lobed chambers it is related to two other Miocene species I have described—*T. basiloba*, from South Carolina, and *T. concentrica*, from the Choctawhatchee marl of Florida. In the peculiar labyrinthine form of the chamber it is not unlike some forms of *Pulvinulina elegans* D'Orbigny, but the shape of the test, chambers, and aperture is different.

***Truncatulina americana* Cushman.**

Plate XX, figures 7, 8.

Truncatulina americana Cushman, U. S. Geol. Survey Bull. 676, p. 63, pl. 20, figs. 2, 3; pl. 21, fig. 1, 1918; U. S. Nat. Mus. Bull. 103, p. 68, pl. 23, figs. 2a-c, 1918.

Test planoconvex, dorsal side nearly flat, ventral side slightly convex, chambers numerous, ten to fifteen in the last-formed coil, rather rapidly increasing in size, peripheral margin subangular, dorsal side with the last few chambers failing to meet the umbilicus, ventral side similar in this respect in most specimens; sutures distinct, slightly limbate on the dorsal side, depressed on the ventral side; wall smooth, punctate, aperture peripheral with a slight lip. Diameter 0.75 millimeter or less.

This species is not so common in the Byram marl as in the Miocene deposits. It is known from the Choctawhatchee marl at Coes Mills and Jackson Bluff, Fla., the Duplin marl at Mayesville, S. C., and Wilmington, N. C., the Yorktown formation at Yorktown, Va., and the Choptank formation at Jones Wharf, Md. I have also recorded it from the lower Miocene of Florida and from the upper Oligocene Culebra formation of the Canal Zone. It is found in the Miocene penetrated by wells in different parts of the peninsula of Florida.

***Truncatulina pseudoungeriana* Cushman, n. sp.**

Plate XX, figure 9.

Truncatulina ungeriana H. B. Brady (not *Rotalina ungeriana* D'Orbigny, 1826), *Challenger* Rept., Zoology, vol. 9, pl. 94, figs. 9a-c, 1884. Cushman, U. S. Nat. Mus. Bull. 103, p. 69, pl. 24, fig. 1, 1918.

Test biconvex, almost equally so; periphery subacute, chambers nine to eleven in the last-

formed whorl, those of the earlier whorls not showing on the dorsal side because they are hidden by the roughness of the surface, or on the ventral side because of the involute character; periphery lobulated; sutures distinct above in the last whorl and very distinct below, as the sutures are somewhat tumid on the ventral side; umbilical region filled nearly flush with the chambers by clear shell material, last few chambers on the dorsal side slightly above the surface on the inner margin; surface dorsally with coarse punctae, below smooth and more finely punctate; aperture at the periphery. Diameter 1 millimeter or less.

In the Byram marl the same form appears that is figured by Brady as *T. ungeriana*. Brady says of his figure, "The drawing (Pl. XCIV, fig. 9) is not a good illustration of the species, the specimen being relatively thicker and altogether more stoutly built than the typical form." A comparison of Brady's figure with that given by D'Orbigny in the Vienna Basin monograph will show the numerous differences in the two. Brady does not give the locality for the specimen from which his drawing was made, but I have seen identical material from the Philippine and Australian regions. The occurrence of this same form in the Byram marl seems to show that the species is distinct and that discrimination will show it to have a definite geographic range in the present ocean. Material from the Oligocene Culebra formation of the Canal Zone that I have referred to *T. ungeriana* may be this new species.

Genus ANOMALINA D'Orbigny.

***Anomalina bilateralis* Cushman, n. sp.**

Plate XXI, figures 1, 2.

Test of about four coils, bilateral or nearly so, composed of numerous chambers, ten or more in the last-formed whorl, umbilical region on both sides with a knob of clear shell material, more pronounced on the dorsal side, chambers smooth but coarsely punctate, more coarsely so on the ventral side, sutures broad and somewhat limbate with clear shell material; aperture a narrow curved opening at the base of the final chamber. Diameter 1 millimeter or less.

This form is rare in the Byram marl. It is close to *A. ammonoides* Reuss but differs from that species as figured by Reuss. It is very close to the form figured in the *Challenger* report by Brady (pl. 94, fig. 2). The *Challenger* material in which Brady found it was almost entirely

from the south Pacific, and it may be predicted that a study of the rather shallow-water material from that region will show that the species there is closely related to if not identical with this one from the Byram marl.

Reuss's original material was from the Cretaceous of Europe. A critical study of the various figures assigned to *A. ammonoides* will show that several forms have been included under the one name.

***Anomalina grosserugosa* (Gümbel) H. B. Brady? var.**

Plate XXI, figures 3-5.

A form in the Byram marl may questionably be referred to this species. It is very close to the form figured by Brady in the *Challenger* report (pl. 94, fig. 4), which is very different from the original of Gümbel, as a comparison of the two will show.

Millett records this species with *A. ammonoides* as widely distributed in the Malay Archipelago, and as both are recorded from a number of stations off the Hawaiian Islands a review of tropical Pacific material should be made to see just what forms are really present there.

***Anomalina mississippiensis* Cushman, n. sp.**

Plate XXI, figures 6-8.

Test small, planoconvex, of about two and one-half coils, periphery slightly lobulate, bluntly rounded, dorsal side very much flattened, even slightly concave, ventral side very convex; chambers comparatively few, six to eight in the last-formed coil, sutures curved, on the dorsal side broad and limbate, even with the surface of clear shell material, on the ventral side narrower and depressed; the last-formed two or three chambers on the inner margin on the dorsal side slightly above the general surface; wall thin and translucent, especially on the dorsal side, smooth; on the ventral side finely punctate and not so clear; aperture a curved opening at the inner margin at the periphery. Length 0.25 to 0.35 millimeter, breadth 0.20 to 0.30 millimeter.

This species is fairly common in the marl at Byram but might easily be overlooked on account of its small size. It is very constant in its chambers and in size and seems to be a well-distinguished little species. In some respects it has affinities with *Truncatulina*

americana Cushman, and in others with *Anomalina grosserugosa* (Gümbel)? var., already mentioned, but it is very distinct from either.

Genus SIPHONINA Reuss, 1849.

***Siphonina advena* Cushman, n. sp.**

Plate XXII, figures 1, 2.

Test unequally biconvex, dorsal side usually less convex than the ventral, periphery subacute, chambers in three or more coils, four chambers making up the last-formed coil, sutures distinct, on the dorsal side flush with the surface, on the ventral side slightly depressed, on the dorsal side somewhat broadened and limbate, ventrally narrow, surface smooth but punctate; aperture with a short neck, compressed, with a phialine lip and elliptical aperture; color even in the fossil specimens somewhat brownish, wall thin and translucent. Diameter 0.50 millimeter or less.

This species is common in the marl at Byram but never shows any of the characters of *S. reticulata* (Czjzek), to which it is related. It is nearer to *S. pulchella* Cushman, from the Miocene of Yumuri River gorge, near Matanzas, Cuba, but differs in the size and shape of the chambers and the character of the sutures.

Genus GYPSINA Carter, 1877.

***Gypsina rubra* (D'Orbigny) Heron-Allen and Earland.**

Plate XXII, figure 3.

Planorbulina rubra D'Orbigny, Annales sci. nat., vol. 7, p. 280, No. 4, 1826.

Fornasini, Acad. sci. Ist. Bologna Mem., 6th ser., vol. 5, p. 44, pl. 2, fig. 3, 1908.

Gypsina rubra (D'Orbigny) Heron-Allen and Earland, Zool. Soc. London Trans., vol. 20, p. 725, pl. 53, figs. 35-37, 1915.

A number of specimens of this species were collected in the marl at Byram.

Although in the fossil specimens the color is of course lacking, the characteristic secondary growth seems to be developed.

This is an Indo-Pacific species recorded by D'Orbigny from the South Seas and Sarawak. Heron-Allen and Earland note its occurrence in the Kerimba Archipelago, off the southeastern coast of Africa. They also record it in shore sands from Fremantle, West Australia, from Lord Howe Island, and from Apia Beach and the Lufi-lufi reef, Samoa, and note that "it is probably widely distributed in shallow water across the Indo-Pacific region."

Genus *PULVINULINA* Parker and Jones, 1862.*Pulvinulina byramensis* Cushman, n. sp.

Plate XXII, figures 4, 5.

Test small, biconvex, rotaliform, consisting of about three coils, seven or eight chambers in the last-formed coil; on the dorsal side sutures oblique and at a considerable angle with the periphery, somewhat limbate; on the ventral side the chambers extend in to the center, which is usually not umbilicate; sutures nearly straight; surface polished, punctations appearing as light tubules against the translucent wall; aperture near the inner end of the chamber on the ventral side, with a definite valvular lip, the aperture hidden below but when examined found to be composed, in the adult, of several adjacent small rounded openings. Diameter 1.5 millimeters or less.

This is a common species in the marl at Byram.

The features of the aperture in this species are peculiar, and with its other characters it seems to be well defined.

Pulvinulina advena Cushman, n. sp.

Plate XXII, figure 8.

Test minute, planoconvex, composed of two and a half coils, periphery deeply lobulate, chambers few, elongate, broadest at the outer end, six or seven in the last-formed whorl, periphery of the chambers somewhat tubulated, remainder of surface slightly papillose on the dorsal side, which is flat, ventral side with each chamber more tumid, sutures depressed and distinct, the surface granulose with coarse, almost spinose projections, chambers continuing in to the umbilicus, where they meet; aperture near the periphery of the test at the base of the last-formed chamber. Diameter 0.20 millimeter.

This species is rare in the Byram marl. It finds its nearest ally, so far as ornamentation shows, in *Rotalia schroeteriana* Parker and Jones var. *inflata* Millett. It has a similar surface ornamentation in the spinose or granular surface and in the fimbriated character of the peripheral margins of the chambers. This variety, described by Millett from specimens obtained in the Malay Archipelago, was found again by Heron-Allen and Earland in the material from the Kerimba Archipelago, off the southeastern coast of Africa.

Pulvinulina glabrata Cushman, n. sp.

Plate XXII, figures 6, 7.

Test biconvex, elongate, somewhat lobulate, composed of about two coils, seven chambers in the last-formed coil, dorsal side convex, the sutures depressed, curved, chambers convex between, rapidly increasing in size as added; dorsal side very coarsely punctate, the sutures somewhat limbate; ventral side umbilicate, surface smooth and with very fine punctations; sutures distinct, last-formed chamber with a long, straight valvular lip across the whole of the depressed umbilicus; aperture beneath the lip. Length 0.5 millimeter.

P. glabrata is rare in the marl at Byram. It differs from such closely related species as *P. auricula*, *P. sagra*, and *P. oblonga* in its very coarsely punctate dorsal surface and the shape of the test. From *P. oblonga*, which has a somewhat similar aperture, it differs in the shorter form of the test. There are a number of records for *P. oblonga* from the Indo-Pacific region, and it would be interesting to know the relation of this Byram marl species to that from the Indo-Pacific.

Genus *ROTALIA* Lamarck, 1804.*Rotalia byramensis* Cushman, n. sp.

Plate XXIII, figure 1.

Test unequally biconvex, rotaliform, in the last-formed coil six or seven chambers, dorsally with the chambers somewhat triangular, the sutures oblique, limbate, broad, of clear shell material; ventral side with a large circular mass in the umbilical region, with the sutures deep and ending in a depressed ring about it; aperture with a somewhat valvular lip often divided into several teeth; surface on the dorsal side somewhat roughened, on the ventral side scrobiculate near the periphery, smoother near the center. Diameter 2 millimeters or less.

This species is not common in the marl at Byram. While it belongs to the *Rotalia beccarii* group, it is much more like the tropical species now living in the Indo-Pacific than those of temperate regions. *R. beccarii* itself is used as a name to cover a great variety of things, and the forms now passing under that name should be more critically treated if their geographic and geologic distribution is to be of value.

***Rotalia dentata* Parker and Jones.**

Plate XXIII, figure 2.

Rotalia dentata Parker and Jones, Philos. Trans., vol. 155, p. 387, pl. 19, fig. 13, 1865.

Several specimens from the marl at Byram are very close to this species from Bombay figured by Parker and Jones. They are also close to the figure given by Brady in the *Challenger* report (pl. 108, fig. 4). *R. dentata* is a different species from *R. calcar*, though probably included under that name by several authors.

As shown in the figure of the type, the sutures are limbate with clear shell material, and the outer border of each whorl is marked in a like manner. The spinose projections from the edge are very much like those in the figure given by Brady and seem to be different from those ordinarily seen in *R. calcar*.

Genus ASTERIGERINA D'Orbigny, 1839.***Asterigerina subacuta* Cushman, n. sp.**

Plate XXIV, figures 1-3.

Test planoconvex or unequally biconvex, composed of about three and one-half coils, the dorsal side slightly convex, smooth, the chambers all visible in well-preserved specimens, even those of the earlier coils showing through the layer of transparent shell material covering them; chambers about ten in the last-formed coil, the sutures oblique and curved backward but not depressed below the surface, slightly thickened and clear, joining at the periphery with the slight keel; from below, the chambers of the last coil only visible; sutures ending at a point about one-third of the way in from the periphery, from which a secondary chamber is developed to the umbilical region, where the sutures come together in a central boss of clear shell material; aperture elongate, curved, at the base of the inner margin on the ventral side. Diameter about 1 millimeter.

Specimens of this species are fairly common in the marl at Byram. It is clearly related to *Asterigerina carinata* D'Orbigny and *A. angulata* Cushman. From the former it differs in the larger number of chambers and the narrower coils, and from the latter in the smaller number of the chambers, simpler aperture, and much narrower coils. *A. subacuta* is nearer *A. carinata* than *A. angulata* but is very constant in its characters. From above it has the appearance of a *Pulvinulina*, but an examination of the ventral side shows the typical

characters of *Asterigerina*. It shows traces of granules on the ventral side near the aperture.

Family NUMMULITIDAE.**Genus NONIONINA D'Orbigny, 1826.*****Nonionina umbilicatulata* (Montagu) Parker, Jones, and H. B. Brady.**

Plate XXIII, figures 3, 4.

There are several specimens from the marl at Byram that at present may be referred to this species. It should be noted, however, that the specimens described by Montagu are different from many of the forms later assigned to his species and that there are apparently several species or varieties which occur in different regions which should be distinguished. The specimens from the Byram marl are very constant in all their characters and are very close to one of the forms figured by Brady in the *Challenger* report (pl. 109, fig. 8). This species is common in comparatively shallow water in the Indo-Pacific region, but in the north Atlantic it is found largely in deeper water. It is to be suspected, therefore, that the species from the Byram marl and that from the Indo-Pacific may be found to be closely allied.

***Nonionina scapha* (Fichtel and Moll) Parker and Jones.**

Plate XXIII, figures 5-7.

Nautilus scapha Fichtel and Moll, Testacea microscopica, p. 105, pl. 19, figs. d-f, 1803.

Nonionina scapha (Fichtel and Moll) Parker and Jones, Annals and Mag. Nat. Hist., 3d ser., vol. 5, p. 102, No. 4, 1860.

H. B. Brady, *Challenger* Rept., Zoology, vol. 9, p. 730, pl. 109, figs. 14, 15, 16?, 1884.

There are two forms of *Nonionina* in the Byram marl, both of which are referred to *N. scapha*. One of them is very close to two of the figures given by Brady in the *Challenger* report (pl. 109, figs. 14, 15). The other is somewhat more elongate. Both forms are figured here to facilitate subsequent reference when the various forms of *Nonionina* found in the Tertiary of the Coastal Plain may be studied as a whole.

Genus NUMMULITES Lamarck, 1801.***Nummulites* sp.**

Plate XXIV, figure 4.

There are a few specimens of *Nummulites* from the marl at Byram of the character

shown in the figure. Definite placing of these forms under a specific name is left until the study of the various species of our Coastal Plain Tertiary is undertaken.

Genus LEPIDOCYCLINA Gumbel, 1868.

***Lepidocyclus supra* (Conrad) H. Douvillé.**

Orbitolites supra Conrad, Acad. Nat. Sci. Philadelphia Proc., No. 2, p. 74, 1865.

Orbitoides supra Conrad, Am. Jour. Sci., 2d ser., vol. 43, p. 31, 1867.

Lepidocyclus supra (Conrad) H. Douvillé, Compt. Rend., 1918, pp. 263, 264, figs. 6-8, 11.

Cushman, U. S. Geol. Survey Prof. Paper 125, p. 69, pl. 26, figs. 5-7, 1920.

Test flattened or slightly sellaeform, typically circular but occasionally irregular with lobes at one side or elongated oval; thickest in the central region but not distinctly umbonate, gradually decreasing in thickness to the periphery; surface apparently smooth but with slight enlargement becoming papillate, the papillae, which are the ends of the pillars, rounded and projecting above the general surface slightly, or where the test is eroded becoming more prominent. Diameter as much as 18 millimeters in adult specimens, thickness about 2 millimeters.

This species is abundant in the Byram marl, of which it is one of the index fossils.

Family MILIOLIDAE.

Genus CORNUSPIRA Schultz, 1854.

***Cornuspira involvens* (Reuss) Reuss.**

Plate XXV, figure 1.

Operculina involvens Reuss, Akad. Wiss. Wien Denkschr., vol. 1, p. 370, pl. 45, fig. 20, 1849.

Cornuspira involvens (Reuss) Reuss, Akad. Wiss. Wien Sitzungsber., vol. 48, p. 39, pl. 1, fig. 2, 1863 [1864].

H. B. Brady, *Challenger Rept.*, Zoology, vol. 9, p. 200, pl. 11, figs. 1-3, 1884.

Cushman, U. S. Nat. Mus. Bull. 71, pt. 6, p. 25, pl. 1, fig. 2; pl. 2, fig. 2, 1917.

There are but a few specimens of this species in the Byram marl. They are smooth and of small size, only about 0.4 millimeter.

The species is very widely distributed. It is common in the shoal waters of the Tropics and reaches a large size in the warm waters of the Indo-Pacific region, as, for example, in the Philippines. Elsewhere it seems to be of small size.

Genus SPIROLOCULINA D'Orbigny, 1826.

***Spiroloculina grateloupi* D'Orbigny.**

Plate XXV, figure 2.

Spiroloculina grateloupi D'Orbigny, Annales sci. nat., vol. 7, p. 298, 1826.

Terquem, Soc. géol. France Mém., 3d ser., vol. 1, p. 52, pl. 5, figs. 5, 6, 1878.

Weisner, Archiv Protisten-Kunde, vol. 25, p. 208, 1912.

Cushman, U. S. Nat. Mus. Bull. 71, pt. 6, p. 31, pl. 4, figs. 4, 5, 1917.

Spiroloculina excavata H. B. Brady (not D'Orbigny), *Challenger Rept.*, Zoology, vol. 9, p. 151, pl. 9, figs. 5, 6, 1884.

The marl from Byram contains a number of specimens which seem nearer to this species than to any other. The periphery, however, is not greatly rounded, but the sides of the test are deeply excavated, and there is a strong keel at the outer edge of each chamber, the neck is produced, and the surface is smooth. One specimen exhibits the series of openings at either end of each coil seen in a number of other species. This is a microspheric specimen.

The species is widely distributed and is especially abundant in the Indo-Pacific, occurring in great numbers in certain parts of the Philippine region and elsewhere in shallow warm waters.

***Spiroloculina byramensis* Cushman, n. sp.**

Plate XXV, figures 4a, 4b.

Test compressed, broadly rounded in side view; peripheral margin squarely truncate, sides of the chambers sloping in somewhat toward the center, surface with a beautiful ornamentation consisting of fine hexagonal depressed areas with very narrow thin ridges between covering the entire surface. Length 0.85 millimeter.

This is rare in the marl at Byram, but its beautifully ornamented surface is very distinctive. It resembles Terquem's figures of *Quinqueloculina variolata* D'Orbigny, from the Pliocene of the Isle of Rhodes.

***Spiroloculina imprimata* Cushman, n. sp.**

Plate XXV, figures 3a, 3b.

Test broad and flat, complanate, nearly circular in outline, composed of numerous chambers, those of the last-formed coil failing to extend to the base of the preceding chamber, leaving a gap; periphery square, lateral faces nearly flat; the surface ornamented by a

series of pits in a more or less linear arrangement. Length about 1 millimeter.

Plate XXV, figure 3b, shows the character of this ornamentation, much enlarged. This is not a common species in the Byram marl, but several specimens were found.

Genus VERTEBRALINA D'Orbigny, 1826.

***Vertebralina advena* Cushman, n. sp.**

Plate XXV, figures 5, 6.

Test compressed, in the adult with three chambers in the final whorl, the chamber angled, surface with numerous strong longitudinal costae, aperture elongate, with a flaring everted lip. Diameter 1 millimeter.

This species is rare in the Byram marl. It may be that some of the specimens which have been assigned to *Articulina sulcata*, based on the figure given by Brady, are *V. advena*. Heron-Allen and Earland record *A. sulcata* from the Kerimba Archipelago. Sidebottom records the species from the Mediterranean, and his figures show that his specimens were evidently *Articulina*. The specimen from the Abrolhos Bank figured by Brady, Parker, and Jones is apparently not the same.

Forms similar to this should be looked for in the tropical Indo-Pacific. A specimen I have figured as *Articulina sulcata*⁹ is very close to if not identical with the Byram marl species.

***Vertebralina* sp.**

Plate XXV, figure 7.

In the marl at Byram was found a single specimen of a very thin, complanate species with numerous distinct anastomosing costae as a surface ornamentation.

It is very distinct from *V. advena*, described above, but the single specimen is not enough for specific determination and description.

Genus QUINQUELOCULINA D'Orbigny.

***Quinqueloculina crassa* D'Orbigny?**

Plate XXVII, figures 1, 2.

Quinqueloculina crassa D'Orbigny, *Annales sci. nat.*, vol. 7, p. 301, No. 14, 1826.

Terquem, *Soc. géol. France Mém.*, 3d ser., vol. 2, pt. 3, p. 186, pl. 20 (28), figs. 20, 21, 1882.

Fornasini, *Accad. sci. Ist. Bologna Mem.*, 6th ser., vol. 2, p. 65, pl. 3, fig. 5, 1905.

Miliolina crassa Heron-Allen and Earland, *Zool. Soc. London Trans.*, vol. 20, p. 572, pl. 42, figs. 37-41, 1915.

⁹ U. S. Nat. Mus. Bull. 71, pt. 6, pl. 22, figs. 5a, b, 1917.

A species that is fairly common in the marl at Byram is rather close to *Q. crassa* as figured by Heron-Allen and Earland from their Kerimba Archipelago material. It is referred questionably to this species. The Byram specimens have perhaps a little finer costae but are otherwise similar to the Kerimba form.

***Quinqueloculina bicostata* D'Orbigny, var.**

Plate XXVI, figures 2-4.

A form of *Quinqueloculina* which is one of the most common fossils in the Byram marl may be referred to *Q. bicostata* D'Orbigny. The specimens are, however, more elongate than the types,¹⁰ or those of Heron-Allen and Earland, from the Kerimba Archipelago.¹¹

The Byram specimens are referred to this species provisionally, but they may represent a distinct variety or species, their main resemblance to the typical form being in the bicostate character of the periphery of the chambers.

The species which perhaps comes nearest to this Byram marl material is that figured by D'Orbigny¹² as *Q. juliana*.

***Quinqueloculina cuvieriana* D'Orbigny.**

Plate XXVI, figure 1.

Quinqueloculina cuvieriana D'Orbigny, in De la Sagra, *Histoire physique, politique et naturelle de l'île de Cuba, Foraminifères*, p. 164, pl. 11, figs. 19-21, 1839.

Cushman, *U. S. Nat. Mus. Bull.* 71, pt. 6, p. 47, pl. 12, fig. 2, 1917.

The typical form of this species described by D'Orbigny from specimens obtained from the shore sands of Cuba occurs very rarely in the marl at Byram. Several authors cite the figures in the *Challenger* report, which do not represent this species but rather *Q. lamareckiana* D'Orbigny. The typical form is found, however, in eastern waters. I have had it from shallow water in Hongkong Harbor, and it occurs elsewhere in the Indo-Pacific region.

The accessory costae at either side of the sharp margin are characteristic of the species.

***Quinqueloculina venusta* Karrer?, var.**

Plate XXVI, figure 5.

This elongate, angled form is somewhat like the form figured by Brady in the *Challenger*

¹⁰ D'Orbigny, A. D., in De la Sagra, Ramón, *Histoire physique, politique et naturelle de l'île de Cuba, Foraminifères*, p. 195, pl. 12, figs. 8-10, 1839.

¹¹ *Zool. Soc. London Trans.*, vol. 20, p. 572, pl. 42, figs. 42-45, 1915.

¹² *Foraminifères fossiles du bassin tertiaire de Vienne*, pl. 20, figs. 1-3, 1846.

report (pl. 5, fig. 5) and placed as *Miliolina venusta* Karrer. The specimens from the Byram marl are even longer and more slender and may not be this species at all. They are figured and noted here so that the form may be made available for later comparisons.

Quinqueloculina sp.?

Plate XXVI, figure 6.

A few specimens from the Byram marl are large (1.50 to 1.75 millimeters long) and have much the form of *Triloculina oblonga* (Montagu) but are quinqueloculine. The surface is in most of them worn and smooth, but in one of the largest, best-preserved specimens there is a faint longitudinal striation. In this connection the note which Heron-Allen and Earland give under *Miliolina oblonga* in their Kerimba work (p. 567) is interesting. "At stations 9 and 12 the specimens were large and showed signs of superficial markings linking the species with *M. striata*."

Genus HAUERINA D'Orbigny, 1846.

***Hauerina fragilissima* (H. B. Brady) Millett.**

Plate XXVII, figure 3.

Spiroloculina fragilissima H. B. Brady, *Challenger* Rept., Zoology, vol. 9, p. 149, pl. 9, figs. 12-14, 1884.

Hauerina fragilissima (H. B. Brady) Millett, Roy. Micr. Soc. Jour., p. 610, pl. 13, figs. 8-10, 1898.

Heron-Allen and Earland, Zool. Soc. London Trans., vol. 20, p. 587, pl. 46, figs. 1, 2, 1915.

Cushman, U. S. Nat. Mus. Bull. 71, pt. 6, p. 64, pl. 24, fig. 4, 1917.

A number of very typical specimens of this species have been identified from the marl at Byram.

All the known records for this species are Indo-Pacific. Brady's original localities are off Tahiti, Society Islands, 420 and 620 fathoms; off Kandavu, Fiji Islands, 255 fathoms; south coast of New Guinea, 3 to 28 fathoms; north coast of New Guinea, 16 to 25 fathoms. Millett records it from the Malay Archipelago. Heron-Allen and Earland found it in material from the Kerimba Archipelago, off the south-eastern coast of Africa. I have found the species in material collected off the Hawaiian Islands in 271 fathoms.

This record from the lower Oligocene Byram marl confirms the Indo-Pacific relations of the Byram fauna.

The test of this species is very thin and of a peculiar opalescent character, the surface

smooth or slightly pitted, the sutures usually appearing as whitish lines in the test.

***Hauerina* sp.?**

Plate XXVII, figure 4.

A single somewhat broken specimen in the marl from Byram belongs to the genus *Hauerina*. It differs from *H. fragilissima* in the sharp edge to the peripheral borders of the chambers, even carinate, and the character of the wall, which though thin and transparent seems to have deep pits or possibly perforations at wide but regular intervals, in a single irregular line down the curved part of the chamber.

Genus ARTICULINA D'Orbigny, 1826.

***Articulina byramensis* Cushman, n. sp.**

Plate XXVII, figures 5, 6.

Test of two portions, a basal triloculine portion followed by a single linear chamber, the earlier portion with the lip of the antepenultimate chamber standing out free at the base, that of the penultimate chamber covered by the base of the last-formed one, last chamber rounded in transverse section or slightly compressed, with a broadly flaring, slightly downward-curved lip; aperture rounded, slightly longer than wide; surface of the test with numerous longitudinal costae, sharp, sometimes, especially in the final chamber, anastomosing. Length 1.25 millimeters.

This is a fairly common species in the marl at Byram and is very constant in its characters. The free lip of the chamber projecting at the base is peculiar and constant in all specimens, and the single linear chamber with very wide lip and the sharply cut, often anastomosing costae are also points that distinguish the species.

A. byramensis is allied to certain of the species usually classed under *A. conico-articulata*. It is close to the specimen from waters off the Hawaiian Islands I have referred to *A. conico-articulata*¹³ and is even more strikingly like the specimens from the Kerimba Archipelago figured by Heron-Allen and Earland¹⁴ as *Articulina sagra* D'Orbigny. This suggests that we have here a definite species, fossil in the Byram marl and living in the Indo-Pacific.

¹³ U. S. Nat. Mus. Bull. 71, pt. 6, pl. 22, figs. 5, 6, 1917.

¹⁴ Zool. Soc. London Trans., pl. 45, figs. 22-23, 1915.

Genus **MASSILINA** Schlumberger, 1893.

Massilina crusta Cushman, n. sp.

Plate XXVIII, figure 1.

Test elliptical, compressed, periphery carinate, early chambers quinqueloculine, later ones 180° from one another, making a flat test, sutures distinct, central portion of each chamber elliptical in transverse section, surface with a slight secondary thickening, the test itself ornamented by a series of very short longitudinal pits, apertural and basal ends of each chamber strongly projecting, the basal end rounded, the aperture rounded with a bifid tooth; surface dull. Length 1.60 millimeters or less.

A few specimens in various stages occurred in the marl at Byram. This species in some ways resembles the figures of *Spiroloculina planissima* (Lamarek) from the Kerimba Archipelago given by Heron-Allen and Earland.¹⁵ Our specimens are, however, much more involute and belong to *Massilina*. The shape of the apertural end and the carinate periphery are very similar in the two forms.

Massilina oclusa Cushman, n. sp.

Plate XXVIII, figure 2.

Test elongate, narrowly elliptical in face view, involute, the peripheral margins squarely truncate, initial end of the chamber projecting backward beyond the former aperture, rounded, apertural end somewhat produced, whole chamber nearly square in transverse section; sutures distinct; aperture rounded, neck square; surface dull, smooth. Length 0.75 millimeter or less.

This species is represented in the marl at Byram by several specimens, all of this same shape and character.

The involute character of the last-formed chambers hides the early chambers almost completely. The whole test has a squarish form that is continued even to the apertural neck. The shape of the initial end of the last-formed chamber is also very constant and characteristic.

Massilina oclusa Cushman, n. sp., var. **costulata** Cushman, n. var.

Test differing from the typical form in the surface, which instead of being smooth and

polished as in the type has an ornamentation of several longitudinal, more or less irregular costae, running out on the neck of the last-formed chamber, the angles of the chambers sharp and carinate, the periphery of the test concave.

This form is rare in the marl at Byram and seems to be either a distinct species or a variety of *M. oclusa*. It may be compared to such forms as *Spiroloculina costigera* Terquem, *S. costata* Terquem, *S. striata* Terquem, and *S. semi-ovata* Terquem, from the Eocene of the Paris Basin, though it is unlike any of these.

Genus **TRILOCULINA** D'Orbigny, 1826.

Triloculina rotunda D'Orbigny.

Triloculina rotunda D'Orbigny, Annales sci. nat., vol. 7, p. 299, No. 4, 1826.

Schlumberger, Soc. zool. France Mém., vol. 6, p. 206, pl. 1, figs. 48-50, figs. 11, 12 (in text), 1893.

Several specimens from the marl at Byram are here referred to this species. They are triloculine, smooth, nearly as broad as long, and the chambers rounded. The longest are about 0.75 millimeter in length.

T. rotunda is recorded from widely separated localities, but there are various forms, as noted in the literature on the species.

Triloculina oblonga (Montagu) D'Orbigny.

Plate XXVIII, figures 3, 4.

Vermiculium oblongum Montagu, Testacea Britannica, p. 522, pl. 14, fig. 9, 1803.

Triloculina oblonga (Montagu) D'Orbigny, Annales sci. nat., vol. 7, p. 300, No. 16, Modèles, No. 95, 1826; in De la Sagra, Histoire physique, politique et naturelle de l'île de Cuba, Foraminifères, p. 155, pl. 10, figs. 3-5, 1839.

Cushman, U. S. Nat. Mus. Bull. 71, pt. 6, p. 69, pl. 26, fig. 3, 1917.

Miliolina oblonga (Montagu) H. B. Brady, Challenger Rept., Zoology, vol. 9, p. 160, pl. 5, figs. 4a, b, 1884. Millett, Roy. Micr. Soc. Jour., p. 267, pl. 5, fig. 14, 1898.

Heron-Allen and Earland, Zool. Soc. London Trans., vol. 20, p. 566, 1915.

A few small but otherwise typical specimens of this species were found in the marl at Byram. They are widest near the base and thence taper to the narrower apertural end; the surface is smooth and polished. Length about 0.35 millimeter.

The specimen figured by Brady seems to be a *Quinqueloculina* and to lack the characteristic shape of the tropical specimens in shallow

¹⁵ Zool. Soc. London Trans., vol. 20, pl. 41, figs. 1-5, 1915.

water. It may be that the Byram specimens and the one I have figured from waters off the Hawaiian Islands, together with that figured by Millett, really constitute a tropical species different from that of British waters.

Triloculina trigonula (Lamarck) D'Orbigny.

Miliolites trigonula Lamarck, Annales du Mus., vol. 5, p. 351, No. 3, 1804; Animaux sans vertèbres, vol. 7, p. 612, No. 3, 1822.

Triloculina trigonula (Lamarck) D'Orbigny, Annales sci. nat., vol. 7, p. 299, No. 1, pl. 16, figs. 5-9, Modèles, No. 93, 1826.

A single specimen of this species was found in the marl at Byram. It is a short, rather rotund form.

Genus **BILOCULINA** D'Orbigny, 1826.

***Biloculina* sp.?**

Plate XXVIII, figures 5, 6.

There are a very few specimens of a small rotund *Biloculina* in the Byram marl. They are smooth with a large aperture and a tooth very small in comparison, as shown in the figure.

PLATES XIV-XXVIII.

PLATE XIV.

- FIGURE 1. *Textularia agglutinans* D'Orbigny. *a*, Front view; *b*, apertural view. $\times 30$.
2. *Textularia sabbaucii* Cushman, n. sp. *a*, Front view; *b*, apertural view. $\times 50$.
3. *Textularia folium* Parker and Jones. Front view of a typical specimen. $\times 100$.
4. *Textularia mississippiensis* Cushman, n. sp. Front view showing the darker secondary covering of the sutures and the periphery. $\times 80$.

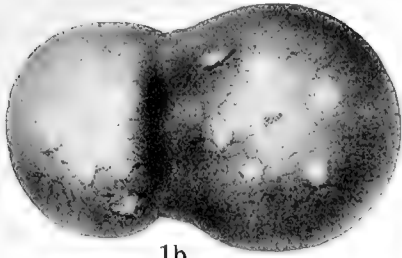

1b

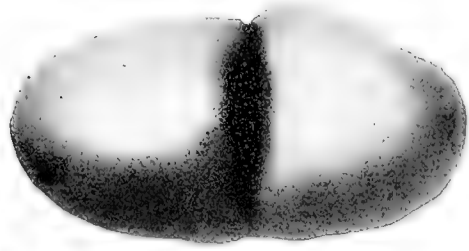

2b



3



1a



2a



4

FORAMINIFERA OF THE BYRAM MARL.



3

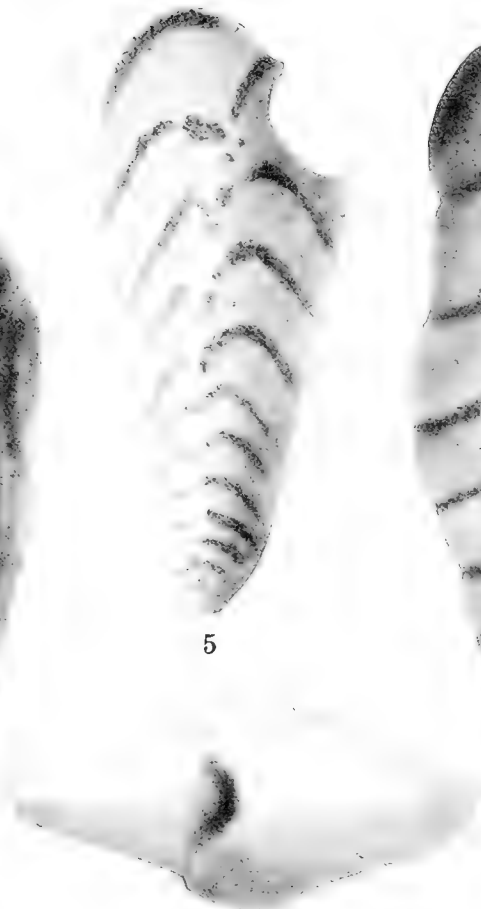

5



1

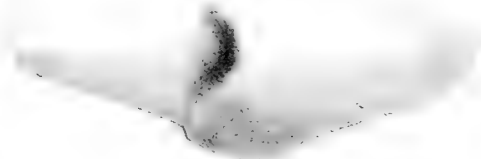

2b



2a



4

PLATE XV.

- FIGURE 1. *Textularia tumidulum* Cushman, n. sp. Front view of adult showing central tumid area. $\times 25$.
2. *Textularia tumidulum* Cushman, n. sp. *a*, Front view; *b*, apertural view of young specimen. $\times 40$.
3. *Bolivina amygdalaformis* H. B. Brady. Front view, showing the anastomosing ornamentation of the early portion and the coarsely pitted last chambers. $\times 120$.
4. *Bolivina nitida* H. B. Brady. Front view. $\times 120$.
5. *Bolivina mississippiensis* Cushman, n. sp. Front view. $\times 160$.

PLATE XVI.

- FIGURE 1. *Clarulina byramensis* Cushman, n. sp. Front view. $\times 30$.
2. *Virgalina* sp.? *a*, Side view, *b*, front view. $\times 120$.
3. *Virgalina* sp.? Front view of another specimen. $\times 120$.
4. *Balimina ovata* D'Orbigny? Front view. $\times 120$.
5. *Nodosaria* sp. Incomplete specimen, with but four chambers, showing form and sculpture. $\times 60$.
6. *Nodosaria* sp. Middle portion of an incomplete specimen with a different surface ornamentation from the preceding. $\times 100$.
7. *Nodosaria?* sp.? Broken specimen of a *Nodosaria* or possibly the linear portion of an *Acticulina*.

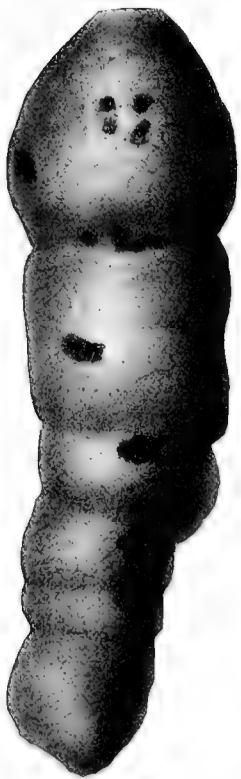

1

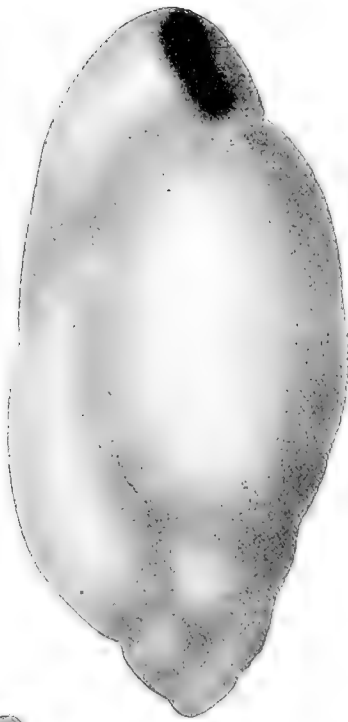

4

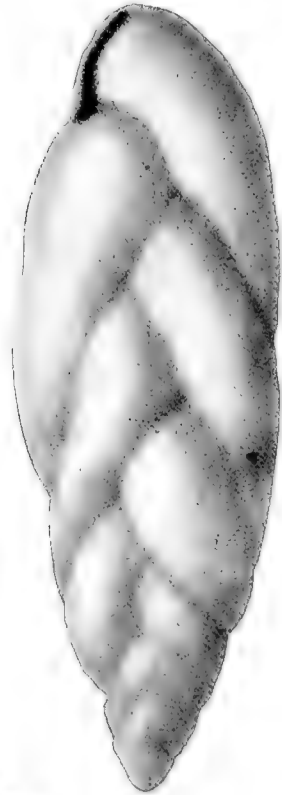

3



5



7

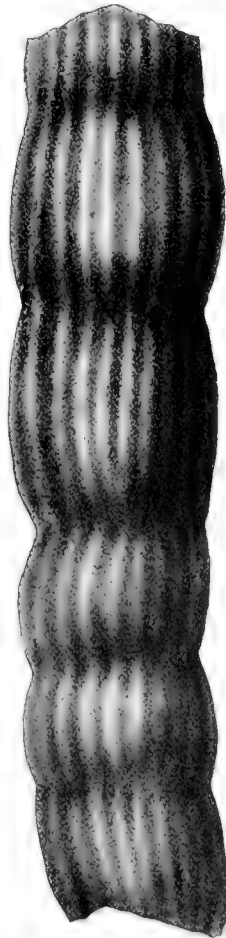

6



2a



2b

FORAMINIFERA OF THE BYRAM MARL.



3



2a



4c

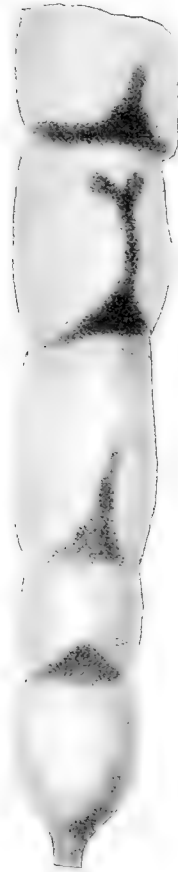

1

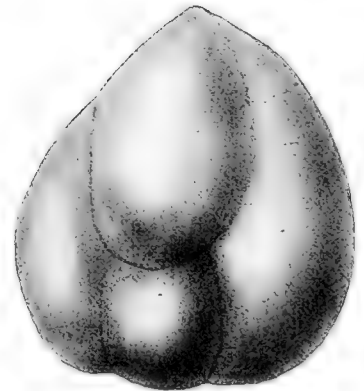

2b



4a



4b

PLATE XVII.

- FIGURE 1. *Vaginulina legumen* (Linnaeus) D'Orbigny var. *degaus* (D'Orbigny) Fornasini? Basal five chambers of an incomplete specimen. $\times 100$.
2. *Polymorphina byramensis* Cushman, n. sp. *a*, View of one side; *b*, opposite side. $\times 60$.
3. *Polymorphina gibba* D'Orbigny. Young specimen. $\times 120$.
4. *Ehrenbergina glabrata* Cushman, n. sp. *a*, Ventral view; *b*, dorsal view; *c*, side view. $\times 120$.

PLATE XVIII.

- FIGURE 1. *Polymorphina problema* D'Orbigny? Front view. $\times 60$.
2. *Polymorphina amygdaloides* Reuss. a, Front view; b, side view. $\times 80$.
3. *Polymorphina gibba* D'Orbigny, fistulose form. a, Front view; b, opposite side. $\times 60$.
4. *Polymorphina rajina* H. B. Brady, Parker and Jones. Front view. $\times 40$.
5. *Uigerina byranensis* Cushman, n. sp. Front view of a specimen without fully developed last chambers.
 $\times 120$.

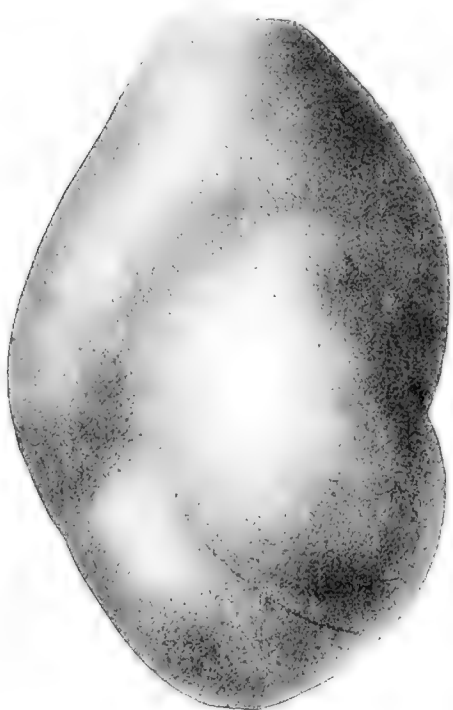

1



2a



2b



5



4



3a



3b

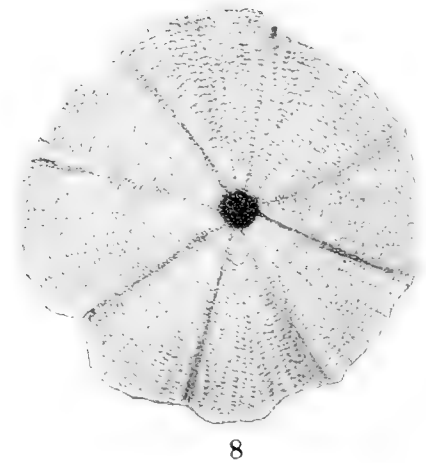
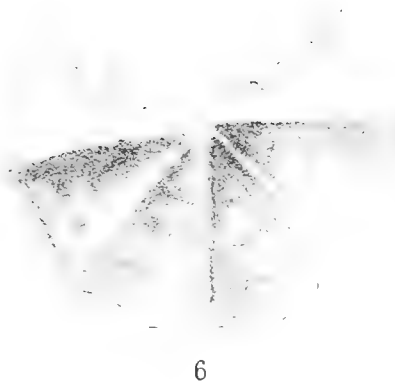
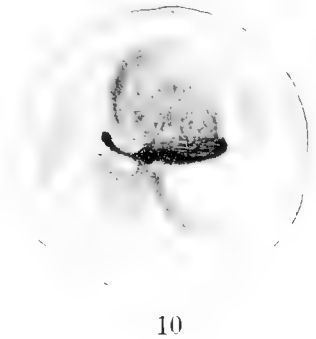
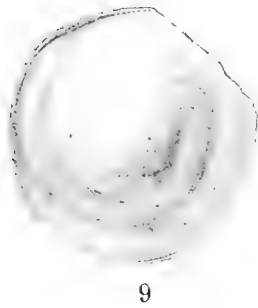
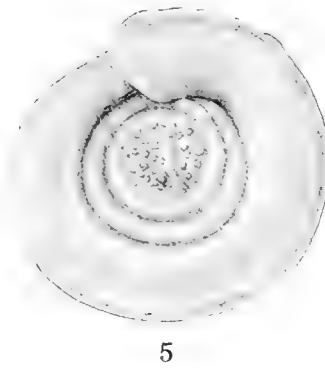
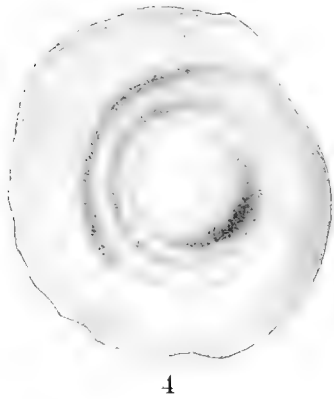
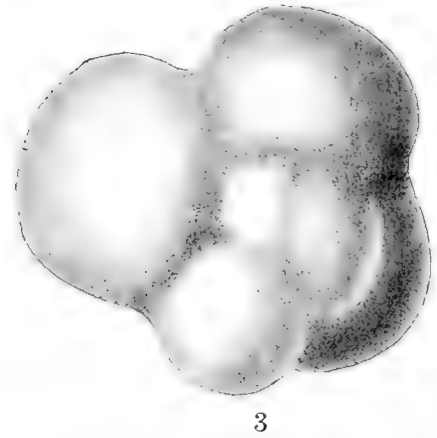
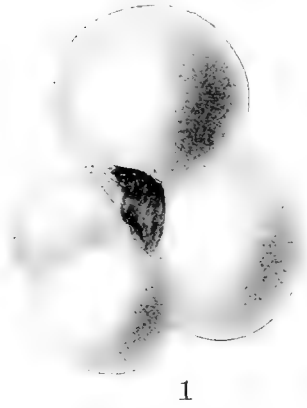

PLATE XIX.

- FIGURE 1. *Globigerina bulloides* D'Orbigny. Ventral view. $\times 80$.
2. *Globigerina bulloides* D'Orbigny. Apertural view of another specimen. $\times 80$.
3. *Globigerina bulloides* D'Orbigny. Dorsal view of another specimen. $\times 80$.
4. *Spirillina subdecorata* Cushman, n. sp. Dorsal view. $\times 80$.
5. *Spirillina subdecorata* Cushman, n. sp. Ventral view. $\times 80$.
6. *Discorbis byramensis* Cushman, n. sp. Dorsal view. $\times 100$.
7. *Discorbis byramensis* Cushman, n. sp. Side view. $\times 100$.
8. *Discorbis byramensis* Cushman, n. sp. Ventral view. $\times 100$.
9. *Discorbis orbicularis* (Terquem) Berthelin. Dorsal view. $\times 80$.
10. *Discorbis orbicularis* (Terquem) Berthelin. Ventral view of another specimen.

PLATE XX.

- FIGURE 1. *Truncatulina lobatula* (Walker and Jacob) D'Orbigny. Ventral view. $\times 80$.
2. *Truncatulina lobatula* (Walker and Jacob) D'Orbigny. Apertural view of another specimen.
3. *Truncatulina lobatula* (Walker and Jacob) D'Orbigny. Dorsal view of another specimen. $\times 80$.
4. *Truncatulina byramensis* Cushman, n. sp. Dorsal view. $\times 80$.
5. *Truncatulina byramensis* Cushman, n. sp. Apertural view of another specimen. $\times 80$.
6. *Truncatulina byramensis* Cushman, n. sp. Ventral view of a young specimen, showing the peculiar lobes at the base of the chambers.
7. *Truncatulina americana* Cushman, n. sp. Ventral view. $\times 80$.
8. *Truncatulina americana* Cushman, n. sp. Dorsal view of another specimen. $\times 80$.
9. *Truncatulina pseudoungaricana* Cushman, n. sp. Ventral view. $\times 100$.



1



4



2



5

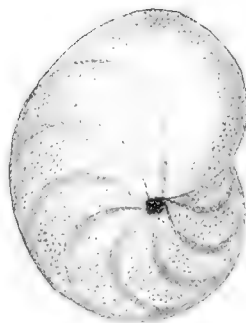

7



6

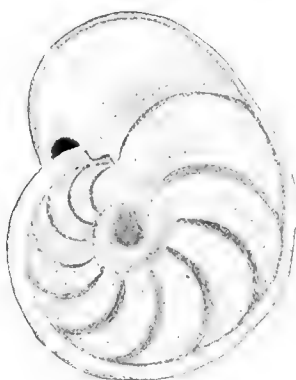

8

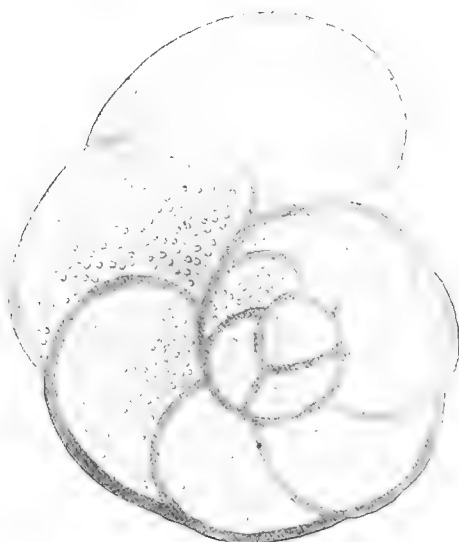

3



9

FORAMINIFERA OF THE BYRAM MARL.

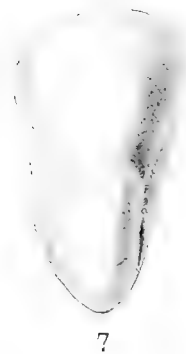
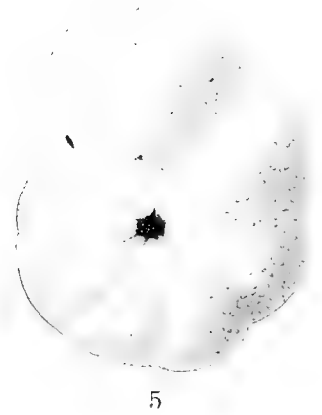
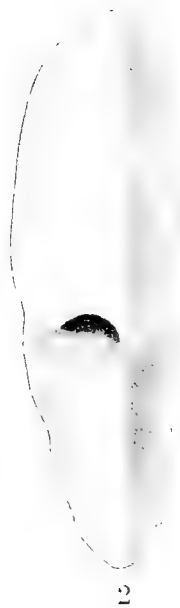
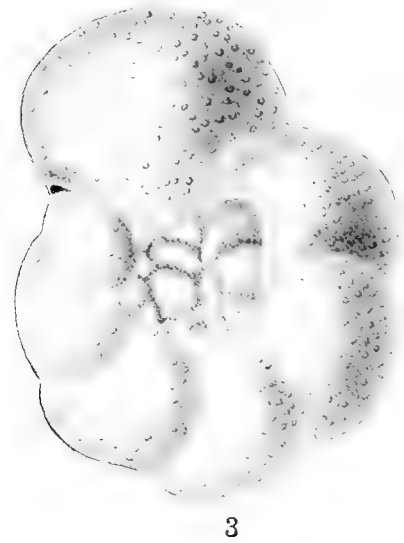

FORAMINIFERA OF THE BYRAM MARL.

PLATE XXI.

- FIGURE 1. *Anomalina bilateralis* Cushman, n. sp. Dorsal view. $\times 80$.
2. *Anomalina bilateralis* Cushman, n. sp. Apertural view of another specimen. $\times 80$.
3. *Anomalina grosserugosa* (Gümbel) H. B. Brady? var. Dorsal view. $\times 80$.
4. *Anomalina grosserugosa* (Gümbel) H. B. Brady? var. Apertural view of another specimen. $\times 80$.
5. *Anomalina grosserugosa* (Gümbel) H. B. Brady? var. Ventral view of another specimen. $\times 80$.
6. *Anomalina mississippiensis* Cushman, n. sp. Ventral view. $\times 80$.
7. *Anomalina mississippiensis* Cushman, n. sp. Apertural view of another specimen. $\times 80$.
8. *Anomalina mississippiensis* Cushman, n. sp. Dorsal view of another specimen. $\times 80$.

PLATE XXII.

- FIGURE 1. *Siphonina adriana* Cushman, n. sp. Side view. $\times 80$.
2. *Siphonina adriana* Cushman, n. sp. Apertural view of another specimen. $\times 80$.
3. *Gypsina rubra* D'Orbigny. Dorsal view. $\times 80$.
4. *Pulvinulina byramensis* Cushman, n. sp. Ventral view. $\times 40$.
5. *Pulvinulina byramensis* Cushman, n. sp. Dorsal view. $\times 40$.
6. *Pulvinulina glabrata* Cushman, n. sp. Dorsal view. $\times 80$.
7. *Pulvinulina glabrata* Cushman, n. sp. Ventral view of a larger specimen, showing the smooth polished surface of the ventral side. $\times 80$.
8. *Pulvinulina adriana* Cushman, n. sp. Dorsal view. $\times 100$.



1

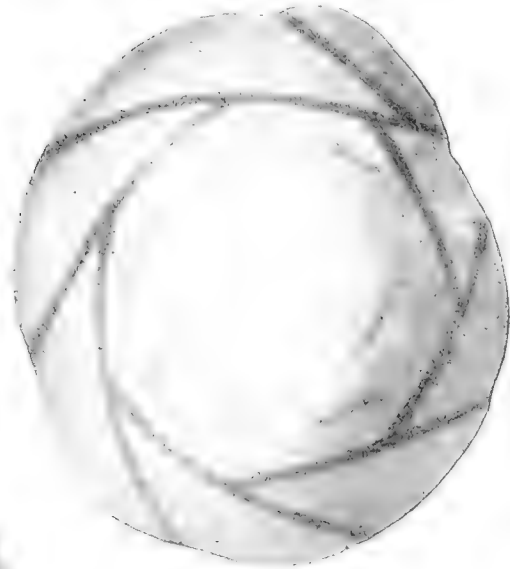

5

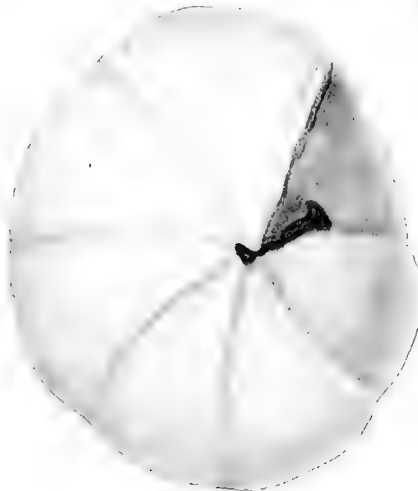

4



7



2

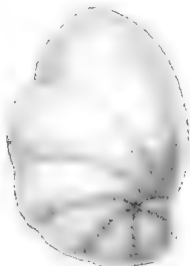

6



8

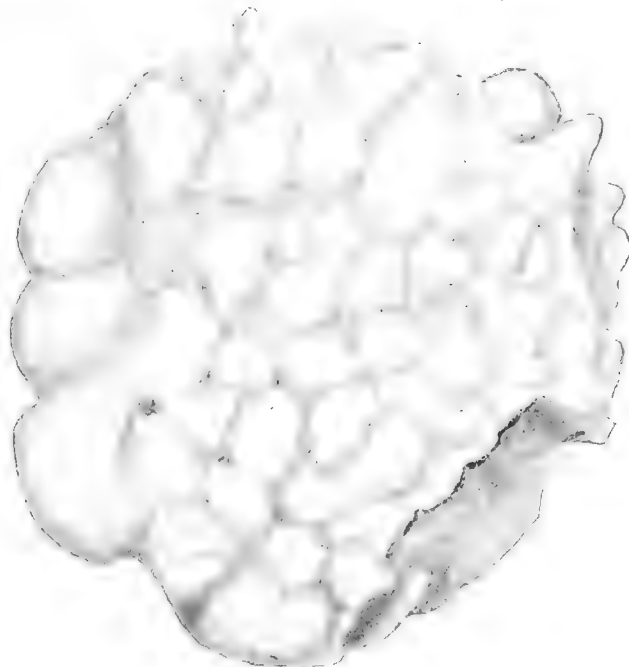

3

FORAMINIFERA OF THE BYRAM MARL.

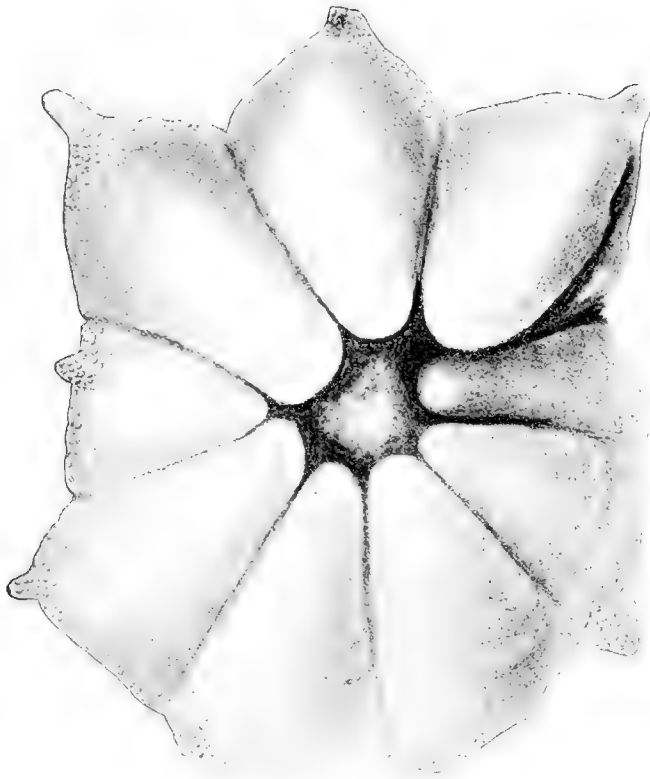

1

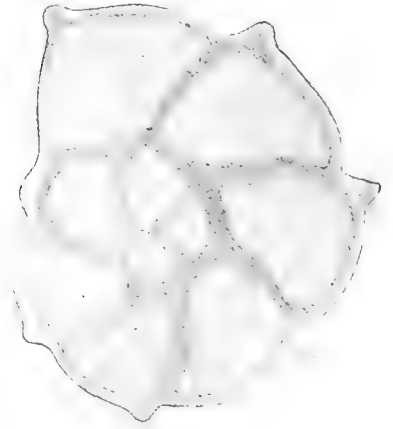

2



4



3



5

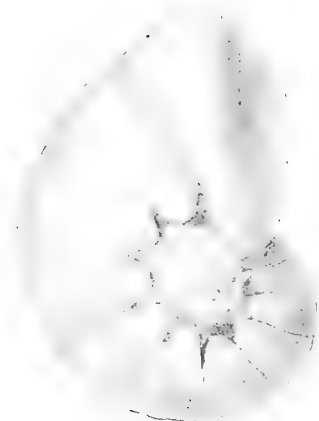

6



7

PLATE XXIII.

- FIGURE 1. *Rotalia byramensis* Cushman, n. sp. Ventral view. $\times 80$.
2. *Rotalia dentata* Parker and Jones? Dorsal view. $\times 80$.
3. *Nonionina umbilicatula* (Montagu) Parker, Jones, and H. B. Brady. Side view. $\times 80$.
4. *Nonionina umbilicatula* (Montagu) Parker, Jones, and H. B. Brady. Apertural view of a nother specimen.
 $\times 80$.
5. *Nonionina scapha* (Fichtel and Moll) Parker and Jones. Apertural view. $\times 80$.
6. *Nonionina scapha* (Fichtel and Moll) Parker and Jones. Side view of another specimen. $\times 80$.
7. *Nonionina scapha* (Fichtel and Moll) Parker and Jones. Side view of a larger, more elongate specimen.
 $\times 80$.

PLATE XXIV.

- FIGURE 1. *Asterigerina subacuta* Cushman, n. sp. Ventral view. $\times 80$.
2. *Asterigerina subacuta* Cushman, n. sp. Dorsal view of a small specimen. $\times 80$.
3. *Asterigerina subacuta* Cushman, n. sp. Side view of another specimen showing the general shape. $\times 80$.
4. *Nummulites* sp. Side view of a somewhat eroded specimen. $\times 40$.



4
FORAMINIFERA OF THE BRYAM MARL.

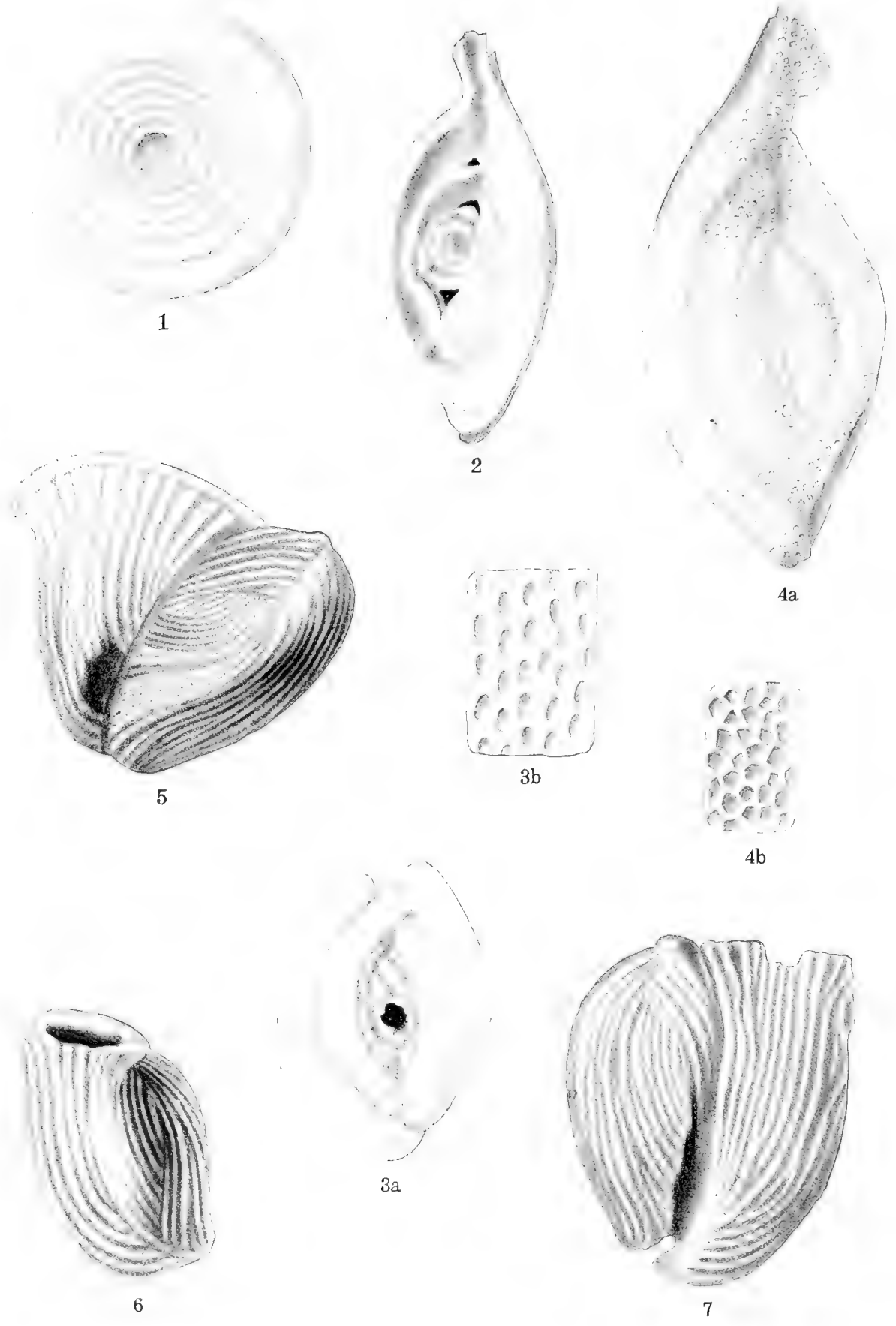

FORAMINIFERA OF THE BRYAM MARL.

PLATE XXV.

- FIGURE 1. *Cornuspira involvens* Reuss. Side view. $\times 100$.
2. *Spiroloculina grateloupi* D'Orbigny. Side view. $\times 80$.
3. *Spiroloculina imprimata* Cushman, n. sp. a, Side view. $\times 40$. b, Surface detail. $\times 200$.
4. *Spiroloculina byramensis* Cushman, n. sp. a, Side view of a partly broken specimen. $\times 40$. b, Surface detail. $\times 200$.
5. *Vertebralina advena* Cushman, n. sp. Side view of an adult specimen. $\times 80$.
6. *Vertebralina advena* Cushman, n. sp. Side view of a young specimen. $\times 80$.
7. *Vertebralina* sp.? Side view showing ornamentation. $\times 80$.

PLATE XXVI.

- FIGURE 1. *Quinquoculina curviana* D'Orbigny. Side view. $\times 80$.
2. *Quinquoculina bicostata* D'Orbigny. Side view. $\times 80$.
3. *Quinquoculina bicostata* D'Orbigny. Apertural view of a third specimen. $\times 80$.
4. *Quinquoculina bicostata* D'Orbigny. Opposite side of another specimen. $\times 80$.
5. *Quinquoculina venusta* Karrer? var. Side view. $\times 80$.
6. *Quinquoculina* sp.? Side view. $\times 40$.



1



6

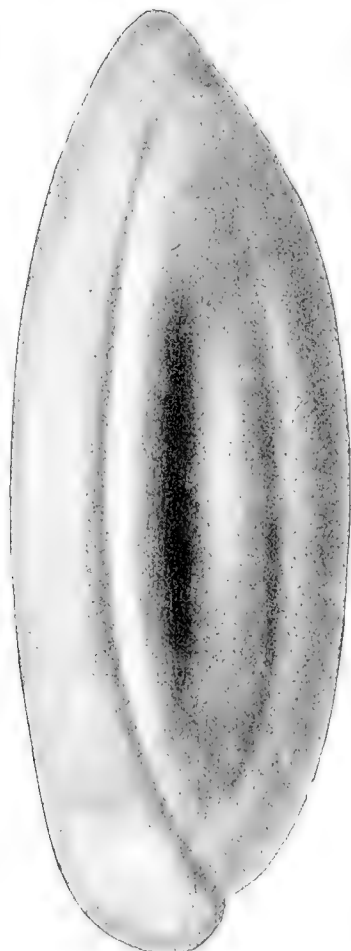

5



2

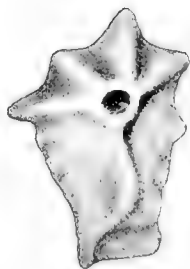

3

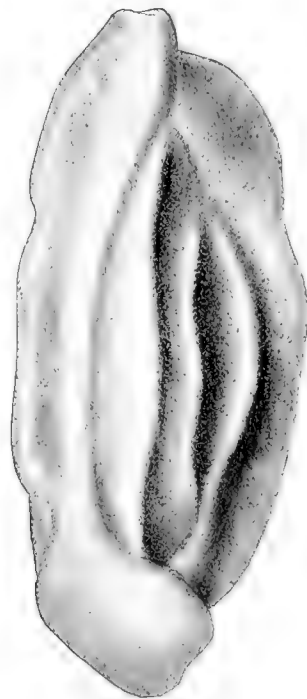

4

FORAMINIFERA OF THE BRYAM MARL.



1



5



6



4

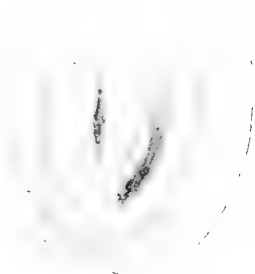

3

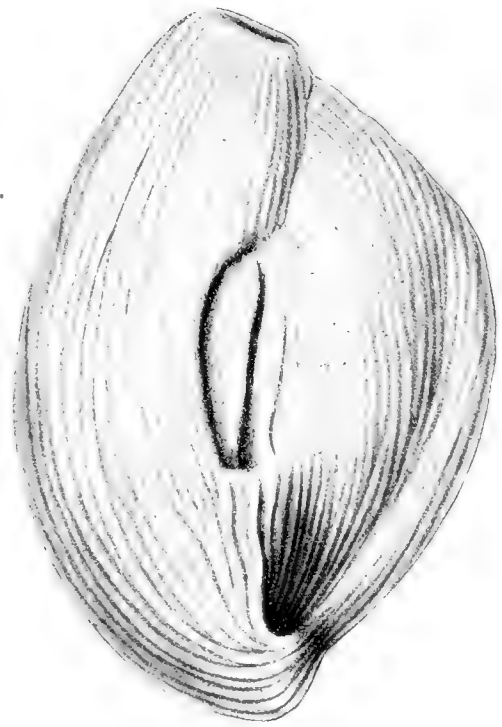

2

FORAMINIFERA OF THE BRYAM MARL.

PLATE XXVII.

- FIGURE 1. *Quinqueloculina crassa* D'Orbigny. Side view. $\times 80$.
2. *Quinqueloculina crassa* D'Orbigny. Opposite side of another specimen. $\times 80$.
3. *Hauerina fragilissima* Brady. Side view. $\times 80$.
4. *Hauerina* sp. Side view of a broken specimen showing peculiar pitted ornamentation of the surface. $\times 80$.
5. *Articulina byramensis* Cushman, n. sp. Side view of specimen which has not yet reached the adult stage.
 $\times 80$.
6. *Articulina byramensis* Cushman, n. sp. Side view of adult specimen. $\times 80$.

PLATE XXVIII.

- FIGURE 1. *Massilina crusta* Cushman, n. sp. Side view. $\times 40$.
2. *Massilina oclusa* Cushman, n. sp. Side view. $\times 80$.
3. *Triloculina oblonga* (Montagu) D'Orbigny. Side view. $\times 80$.
4. *Triloculina oblonga* (Montagu) D'Orbigny. Opposite side of another specimen. $\times 80$.
5. *Biloculina* sp.? Apertural view, showing aperture and tooth. $\times 40$.
6. *Biloculina* sp.? Side view of another specimen. $\times 40$.



1



2



4



3

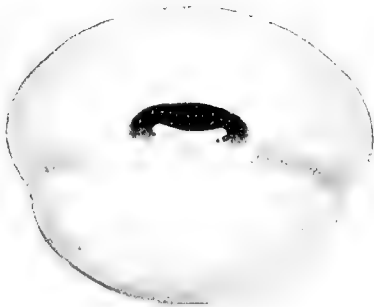

5



6

FORAMINIFERA OF THE BRYAN MARL.

THE FORAMINIFERA OF THE MINT SPRING CALCAREOUS MARL MEMBER OF THE MARIANNA LIMESTONE.

By JOSEPH A. CUSHMAN.

INTRODUCTION.

The Mint Spring calcareous marl member of the Marianna limestone, a lower Oligocene series of beds of the Coastal Plain region, was defined by C. Wythe Cooke¹ as follows:

The "chimney rock" facies of the Marianna limestone is replaced in western Mississippi by sands and shell marls for which the name Mint Spring calcareous marl is here proposed. The name is derived from Mint Spring Bayou, a small stream entering Centennial Lake just south of the National Cemetery at Vicksburg. The strata to which the name is applied are exposed beneath a waterfall in the lower course of the stream.

Between Vicksburg and Pearl River the Mint Spring marl occupies the entire interval between the Forest Hill sand and the Glendon limestone, but east of Pearl River it is overlain by a thickening wedge of the Marianna "chimney rock." It has not been recognized east of Chickasawhay River, on which it is exposed 1½ miles northwest of the mouth of Limestone Creek. Other important exposures are along Glass Bayou at Vicksburg and at Haynes Bluff, 14 miles north of Vicksburg, where it is 25 feet thick.

The type station may be taken as U. S. G. S. station 6452, shell and sand bed at foot of high waterfall, Mint Spring Bayou, Vicksburg, Miss.; C. W. Cooke, collector.

The other stations represented in the collections here described are as follows:

6451. Same locality as station 6452; E. N. Lowe and C. W. Cooke, collectors.

6447, 6448. Foot of a high waterfall in Glass Bayou, near Vicksburg, Miss.

6647. Chickasawhay River 1½ miles northwest of Limestone Creek, 4 miles northwest of Waynesboro, and 1½

miles southwest of Boice, Wayne County, Miss.; C. W. Cooke, collector.

7671. "Brown's Cave," east bluff of Leaf River half a mile above the bridge on Bay Springs-Raleigh road, in sec. 13, T. 2 N., R. 8 E., Smith County, Miss.; C. W. Cooke, collector.

The distribution of the species at these stations and of those species which also occur in the younger Byram calcareous marl at its type station is indicated in the accompanying table.

As noted in my paper on the Byram marl,² many of the species are closely related to those now found living in the Indo-Pacific region. An added example of this relation is *Spirillina limbata* H. B. Brady var. *bipunctata* Cushman, n. var., which is a variety in the Mint Spring marl of a species that is characteristic of the Indo-Pacific.

The fauna evidently represents more than a shoal-water deposit, as it lacks certain of the genera present in the Byram marl which indicate shallow water and has a greater abundance of species which indicate deeper water. The occurrence of numerous Lagenidae indicates a depth of perhaps 50 fathoms, and the lack of such genera as *Heterostegina*, *Operculina*, and *Amphistegina* indicates a depth of more than 20 or 30 fathoms. This statement is based on data obtained from a study of Foraminifera in the Tortugas region in the Gulf of Mexico as well as of their distribution in the Philippine region.

A systematic treatment of the species follows.

¹ Washington Acad. Sci. Jour., vol. 8, No. 7, p. 195, 1918.

² U. S. Geol. Survey Prof. Paper 129-E, 1922.

Distribution of Foraminifera of the Mint Spring marl and Byram marl.

	Mint Spring marl.						Byram marl.
	6452	6451	6447	6448	6647	7671	6455
<i>Textularia tumidulum</i> Cushman.....	×	×	×	×		×	×
<i>mississippiensis</i> Cushman.....	×	×	×	×	×	×	×
<i>subhauerii</i> Cushman.....					×		×
<i>Bolivina</i> cf. <i>B. punctata</i> D'Orbigny.....		×					
<i>cookei</i> Cushman, n. sp.....			×		×	×	
<i>vicksburgensis</i> Cushman, n. sp.....							
<i>frondea</i> Cushman, n. sp.....							
<i>Verneuilina rectimargo</i> Cushman, n. sp.....	×	×	×	×			
<i>Gaudryina triangularis</i> Cushman.....						×	
sp. ?.....		×					
<i>Bulimina pupoides</i> D'Orbigny.....					×	×	
<i>Buliminella subteres</i> H. B. Brady var. <i>angusta</i> Cushman, n. var.....					×	×	
<i>contraria</i> (Reuss).....					×		
<i>Cassidulina crassa</i> D'Orbigny.....							
<i>Lagena laevigata</i> (Reuss).....		×					
<i>striata</i> (D'Orbigny) var. <i>substriata</i> Williamson.....						×	
<i>orbignyana</i> (Seguenza) var. <i>flintii</i> Cushman, n. var.....			×				
<i>hexagona</i> (Williamson).....	×						
<i>Nodosaria communis</i> D'Orbigny.....		×				×	
<i>filiformis</i> D'Orbigny.....						×	
<i>obliqua</i> (Linnaeus).....						×	?
sp. ?.....						×	
<i>Cristellaria convergens</i> Bornemann.....						×	
<i>cultrata</i> (Montfort).....						×	
<i>rotulata</i> (Lamarck).....						×	
<i>vicksburgensis</i> Cushman, n. sp.....						×	×
<i>Vaginulina legumen</i> (Linnaeus) var. <i>elegans</i> (D'Orbigny).....							×
<i>Polymorphina byramensis</i> Cushman.....	×	×	×	×	×	×	×
<i>regina</i> H. B. Brady, Parker, and Jones.....	×			×		×	×
<i>problema</i> D'Orbigny.....	×				×	×	×
<i>gibba</i> D'Orbigny.....		×	×		×	×	×
<i>amygdaloides</i> Reuss?.....						×	×
<i>equalis</i> D'Orbigny.....		×					×
<i>advena</i> Cushman, n. sp.....							×
<i>cuspidata</i> H. B. Brady.....							×
var. <i>costulata</i> Cushman, n. sp.....							×
<i>vicksburgensis</i> Cushman, n. sp.....							×
<i>spinosa</i> (D'Orbigny).....		×	×		×	×	
<i>Uvigerina byramensis</i> Cushman.....	×	×	×		×	×	×
<i>pigmea</i> D'Orbigny.....	×				×	×	×
<i>Globigerina bulloides</i> D'Orbigny.....	×	×	×			×	×
<i>duertrei</i> D'Orbigny.....					×	×	
<i>Spirillina limbata</i> H. B. Brady var. <i>bipunctata</i> Cushman, n. var.....	×	×	×			×	
<i>Patellina advena</i> Cushman, n. sp.....							
<i>Discorbis auracana</i> (D'Orbigny).....			×				
<i>bertheloti</i> (D'Orbigny).....	×	×					
<i>Truncatulina lobatula</i> (Walker and Jacob).....	×	×		×	×	×	×
<i>byramensis</i> Cushman.....	×	×	×	×			×
<i>americana</i> Cushman, var.....	×	×	×	×			×
<i>pseudoungeriana</i> Cushman.....		×	×		×	×	×
<i>vicksburgensis</i> Cushman, n. sp.....				×			×
<i>Anomalina bilateralis</i> Cushman.....		×		×	×	×	×
<i>mississippiensis</i> Cushman.....	×	×	×	×	×	×	×
<i>vicksburgensis</i> Cushman, n. sp.....							×
<i>Siphonia advena</i> Cushman.....	×	×	×	×	×	×	×
<i>Gypsina rubra</i> (D'Orbigny).....	×				×	×	×
<i>Pulvinulina byramensis</i> Cushman.....	×	×	×	×	×	×	×
<i>glabrata</i> Cushman.....	×	×		×		×	×
<i>Rotalia byramensis</i> Cushman.....			×	×			×
<i>dentata</i> Parker and Jones var. <i>parva</i> Cushman, n. var.....	×	×	×	×			×
<i>vicksburgensis</i> Cushman, n. sp.....	×	×		×	×	×	×
<i>Nonionina umbilicatula</i> (Montagu).....	×		×	×	×	×	×
<i>scapha</i> (Fichtel and Moll).....	×	×	×	×		×	×
<i>advena</i> Cushman, n. sp.....					×		×
<i>Coronaspira involvens</i> (Reuss).....	×	×	×				×

Distribution of Foraminifera of the Mint Spring marl and Byram marl—Continued.

	Mint Spring marl.						Byram marl.
	6452	6451	6447	6448	6647	7671	6455
<i>Spiroloculina imprimata</i> Cushman.....		×					×
<i>antillarum</i> D'Orbigny.....	×	×					
<i>Vertebralina</i> sp. ?.....		×					
<i>Quinqueloculina bicostata</i> D'Orbigny.....		×		×			×
<i>cuvieriana</i> D'Orbigny.....	×		×				×
<i>vicksburgensis</i> Cushman, n. sp.....			×				×
<i>cookei</i> Cushman, n. sp.....		×					
<i>glabrata</i> Cushman, n. sp.....	×	×	×				
<i>lustra</i> Cushman, n. sp.....				×			
<i>tessellata</i> Cushman, n. sp.....		×	×				
<i>vulgaris</i> D'Orbigny.....	×	×	×	×			
<i>seminulum</i> (Linnaeus).....	×	×	×				
<i>contorta</i> D'Orbigny.....	×	×		×			
<i>lamarckiana</i> D'Orbigny.....			×				
<i>Articulina byramensis</i> Cushman.....	×	×					×
<i>Massilina decorata</i> Cushman, n. sp.....	×				×	×	
<i>Triloculina peroblonga</i> Cushman, n. sp.....		×					
<i>sculpturata</i> Cushman, n. sp.....		×	×				
<i>Biloculina ornata</i> D'Orbigny.....	×	×					

DESCRIPTIONS.

Family TEXTULARIIDAE.

Genus TEXTULARIA DeFrance, 1824.

Textularia tumidulum Cushman.

Textularia tumidulum Cushman, U. S. Geol. Survey Prof. Paper 129, p. 89, pl. 15, figs. 1, 2a, 2b, 1922.

Test large, elongate, compressed, thickest in the central region, thence thinning toward the periphery, initial end rapidly broadening in the adult, the sides nearly parallel to a point near the apertural end, where the breadth of the test is often reduced; chambers numerous, in the adult about three times as wide as high, and often the last-formed chamber in old-age specimens somewhat distinctly set off from the others, the inner portion of each chamber much thicker than the other portions and in the rapid decrease in thickness often leaving a channel running lengthwise of the test between this central tumid area and the gradually sloping outer portion, usually well marked in adult specimens; sutures not very distinct; wall arenaceous, but smoothly finished. Length 2.5 millimeters or less.

This is the most common species of *Textularia* in the Mint Spring marl, occurring at the type station (6452, Mint Spring Bayou, Vicksburg, Miss.) and also at the following stations:

6447, 6448. Glass Bayou, Vicksburg, Miss.

6451. Mint Spring Bayou, Vicksburg, Miss.

7671. "Brown's Cave," Leaf River, Miss.

32333°—22—10

There is a considerable variation in relative length and breadth in the two forms of the species, the megalospheric form being usually broader and shorter, the microspheric form narrower but longer. The species was originally described from specimens obtained in the Byram marl at Byram, Miss.

Textularia mississippiensis Cushman.

Textularia mississippiensis Cushman, U. S. Geol. Survey Prof. Paper 129, p. 90, pl. 14, fig. 4, 1922.

Test elongate, fairly broad, thickest in the middle, thence thinning toward the periphery, in end view biconvex, central portion curved; chambers rather low and broad, especially in the early stages, becoming higher in the adult and often less broad so that the later chambers in the adult make a test less wide than at earlier stages; sutures covered by a coarsely arenaceous layer meeting in the center and at the periphery, leaving the central portion of each chamber uncovered; periphery irregular, not definitely or regularly spinose; chamber walls smooth and finely perforate. Length 0.40 to 0.75 millimeter.

This species, which was originally described from specimens obtained in the Byram marl at Byram, Miss, occurs at all six stations of the Mint Spring marl, as follows:

6447, 6448. Glass Bayou, Vicksburg, Miss.

6451, 6452. Mint Spring Bayou, Vicksburg, Miss.

6647. Chickasawhay River 1½ miles southwest of Boice, Miss.

7671. "Brown's Cave," Leaf River, Miss.

The sutures are not always covered with a coarsely arenaceous layer but are typically so; this layer is often darker than the test and very distinct. Both megalospheric and microspheric forms occur. None of the specimens seem to have any definite regular spinose edge, and this is also true of the Byram specimens. The specimens in the Mint Spring marl seem to run slightly larger than those in the Byram marl; otherwise they are very similar.

Textularia subhauerii Cushman.

Textularia subhauerii Cushman, U. S. Geol. Survey Prof. Paper 129, p. 89, pl. 14, figs. 2a, 2b, 1922.

Test large, stout, elongate, early portion rapidly increasing in width with each newly added chamber, later adult portion with the sides nearly parallel, slightly lobulate; periphery rounded but the median portion nearly flat; chambers eighteen to twenty, increasing in height as added, those of the later portion nearly as high as broad, sutures usually rather indistinct; wall coarsely arenaceous but smoothly finished on the exterior; aperture at the base of the inner margin of the chamber. Length 2 millimeters or less.

The only station at which this species was obtained in the Mint Spring marl is station 6647 (Chickasawhay River $1\frac{1}{2}$ miles southwest of Boice, Miss.), at which there were numerous specimens. This is the only station of the six at which *Textularia tumidulum* did not occur. The specimens agree well with those from the Byram marl described in the paper cited.

Genus **BOLIVINA** D'Orbigny, 1839.

Bolivina cf. *B. punctata* D'Orbigny.

Test small, elongate, slightly tapering, composed of about twenty chambers; periphery slightly rounded; sutures distinct; wall finely punctate. Length about 0.25 millimeter.

A single specimen was obtained at station 6451, Mint Spring Bayou, Vicksburg, Miss. It is very small and in its general characters is like the recent material of the Gulf of Mexico which I have referred to *Bolivina punctata* D'Orbigny.

Bolivina cookei Cushman, n. sp.

Plate XXIX, figure 1.

Test elongate, tapering, the early portion with the periphery slightly rounded, thick, the later portion with the periphery subacute and

the whole test broader and thinner; chambers numerous; sutures indistinct; surface of the earlier thickened portion ornamented by numerous fine longitudinal costae; later portion smooth but finely punctate. Length 0.25 to 0.35 millimeter.

Type specimen from station 6647, Chickasawhay River $1\frac{1}{2}$ miles southwest of Boice, Miss. Single specimens also occur at stations 6447 (Glass Bayou, Vicksburg, Miss.) and 7671 ("Brown's Cave," Leaf River, Miss.).

This is a small species but distinct in its general character. The last-formed portion differs from the early part in its broader form and smooth surface, the early part being much thicker and ornamented by fine longitudinal costae. Young specimens do not show the later characters.

The species is named for C. Wythe Cooke, of the United States Geological Survey, who has collected most of the material used in the present paper.

Bolivina vicksburgensis Cushman, n. sp.

Plate XXIX, figure 2.

Test elongate, tapering, apical end bluntly pointed, gradually increasing in breadth for several chambers, after which the sides are nearly parallel during the remainder of the growth; chambers distinct; sutures excavated; proximal angle of the periphery of each chamber somewhat projecting beyond the general line of the test, forming a serrate edge; chambers distinctly triangular; sutures oblique; surface with numerous punctations arranged generally in longitudinal lines. Length 0.45 millimeter.

Type specimen from station 6451, Mint Spring Bayou, Vicksburg, Miss. This species seems to be rare, not being found at any of the other stations. It is distinct from any others found in the Mint Spring marl or the Byram marl. It can be distinguished by the peculiar serrate periphery and the ornamentation.

Bolivina frondea Cushman, n. sp.

Plate XXIX, figure 3.

Test much compressed, broad, composed of several chambers, those of the early portion elongate, forming a narrow test, those of the adult extending back, forming a broad test similar to that seen in certain species of *Fron-dicularia*; sutures distinct; wall smooth; periph-

ery broadly rounded. Length slightly more than 1 millimeter.

Type specimen from station 6647, Chickasawhay River $1\frac{1}{4}$ miles southwest of Boice, Miss.

This is a very peculiar species which at first glance would be taken for the young of *Fron-dicularia*, but a further study shows that the chambers are alternating throughout, as in *Bolivina*; in some respects it remotely resembles *B. semialata* Bagg, which occurs off the Hawaiian Islands.

Genus **VERNEUILINA** D'Orbigny, 1840.

Verneuilina rectimargo Cushman, n. sp.

Plate XXIX, figures 4, 5.

Test elongate, triangular in cross section, early portion tapering, adult portion with the sides nearly parallel and straight; chambers numerous, arranged triserially; sutures not depressed, often slightly limbate; sides of the test flattened or very slightly concave; peripheral angles rounded; aperture slightly elongate at the base of the inner margin of the last-formed chamber; wall finely punctate. Length 1 millimeter or less.

Type specimen from station 6452, Mint Spring Bayou, Vicksburg, Miss. Specimens were also found in the Mint Spring marl at the following stations:

6447, 6448. Glass Bayou, Vicksburg, Miss.

6451. Mint Spring Bayou, Vicksburg, Miss.

This is a much longer species than *V. spinulosa glabrata*, which occurs in the Byram marl, and can be easily distinguished from it.

Genus **GAUDRYINA** D'Orbigny, 1839.

Gaudryina triangularis Cushman.

Gaudryina triangularis Cushman, U. S. Nat. Mus. Bull. 71, pt. 2, p. 65, figs. 104 a-c (in text), 1911; U. S. Nat. Mus. Bull. 103, p. 56, pl. 20, fig. 3, 1918; Carnegie Inst. Washington Pub. 291, p. 35, 1919.

Test slightly longer than broad, for the most part triangular, the angles rather acute, composed of a series of chambers triserially arranged, the later chambers rotund, biserially arranged, few in number; walls coarsely arenaceous, more or less smoothly finished; sutures plainly visible on the exterior; aperture narrow, between the inner border of the chamber and the preceding chamber; color gray. Length about 1 millimeter.

A single specimen from station 7671 ("Brown's Cave," Leaf River, Miss.) may belong to this species. It was originally described from specimens obtained off the Hawaiian Islands and is recorded as occurring near the Bonin Islands. I have also identified it in the Miocene marl from the gorge of Yumuri River, Matanzas, Cuba, and in the Oligocene from the lower part of the Culebra formation in the Canal Zone.

Genus **Gaudryina** sp.?

Plate XXIX, figure 6.

There is a specimen from U. S. G. S. station 6451 (waterfall in Mint Spring Bayou, Vicksburg, Miss.; E. N. Lowe and C. W. Cooke, collectors) which is apparently a *Gaudryina*, but it is not well enough characterized for description.

Genus **BULIMINA** D'Orbigny, 1826.

Bulimina pupoides D'Orbigny.

Plate XXIX, figure 7.

Bulimina pupoides D'Orbigny, Foraminifères fossiles du bassin tertiaire de Vienne, p. 185, pl. 11, figs. 13, 14, 1846.

H. B. Brady, *Challenger* Rept., Zoology, vol. 9, p. 400, pl. 50, figs. 15a, b, 1884.

Cushman, U. S. Nat. Mus. Bull. 71, pt. 2, p. 80, figs. 132 a-c (in text), 1911.

Test ovate, broadest near the apertural end; apical end bluntly pointed, tapering; end view nearly circular; visible chambers numerous, much inflated; sutures rather deeply depressed; wall smooth; aperture long and narrow, with a narrow platelike tooth; color white. Length about 1 millimeter.

There are single specimens which may be referred to this species from the following stations:

6647. Chickasawhay River $1\frac{1}{4}$ miles southwest of Boice, Miss.

7671. "Brown's Cave," Leaf River, Miss.

They are much longer than *B. ovata*, which occurs in the Byram marl.

Genus **BULIMINELLA** Cushman, 1911.

Buliminella subteres H. B. Brady var. *angusta* Cushman, n. var.

Plate XXIX, figures 8, 9.

Variety differing from the typical species in the more elongate, narrower shape of the test and the larger number of chambers; aperture elongate, nearly in the long axis of the test;

sutures not depressed, marked by darker lines of shell material. Length 0.6 millimeter.

Type specimen from station 6647, Chickasawhay River $1\frac{1}{4}$ miles southwest of Boice, Miss. It also occurred at these stations:

6447. Glass Bayou, Vicksburg, Miss.

6452. Mint Spring Bayou, Vicksburg, Miss.

7671. "Brown's Cave," Leaf River, Miss.

Specimens were very rare at all these stations. The typical form of the species occurs in the present oceans in the warmer parts of the Atlantic and in the Indo-Pacific. It has not been recorded as a fossil in the American Tertiary.

Buliminella contraria (Reuss) Cushman.

Rotalina contraria Reuss, Deutsch. geol. Gesell. Zeitschr., vol. 3, p. 76, pl. 5, fig. 37, 1851.

Buliminella contraria (Reuss) Cushman, U. S. Nat. Mus. Bull. 71, pt. 2, p. 89, figs. 143 a-c (in text), 1911.

Bulimina contraria (Reuss) H. B. Brady, *Challenger* Rept., Zoology, vol. 9, p. 409, pl. 54, figs. 18 a-c, 1884.

Test coiled in a depressed spire, umbilicate, the chambers numerous, slightly inflated; sutures distinct, slightly depressed; wall smooth, calcareous; aperture distinctly bulimine, loop-like, rather long and narrow, extending to the umbilicus; color white. Length 0.65 millimeter.

There is a single specimen from station 6647 (Chickasawhay River $1\frac{1}{4}$ miles southwest of Boice, Miss.) which seems to be nearer to this than to any other species of the genus. The records for *B. contraria* are mostly from the south Pacific. Brady records one specimen from off the Azores, and I have recorded it from off the Hawaiian Islands. Bagg records very small specimens from the Pliocene sands of San Pedro, Calif. This is another of the species which seems to show the relation of the lower Oligocene of the Coastal Plain of the United States to the recent fauna of the Indo-Pacific.

Genus CASSIDULINA D'Orbigny, 1826.

Cassidulina crassa D'Orbigny.

Cassidulina crassa D'Orbigny, Voyage dans l'Amérique méridionale, Foraminifères, p. 56, pl. 7, figs. 18-20, 1839.

H. B. Brady, *Challenger* Rept., Zoology, vol. 9, p. 429, pl. 54, figs. 4, 5, 1884.

Cushman, U. S. Nat. Mus. Bull. 71, pt. 2, p. 97, figs. 151 a-c (in text), 1911.

Outline subcircular or oval, biconvex, with a broadly rounded peripheral border; chambers rather few, short, and inflated, the surface depressed at the sutures; wall calcareous, per-

forate, smooth; aperture a long, narrow slit just below and nearly parallel to the periphery of the test. Diameter 0.4 millimeter.

There are specimens from stations 6447 (Glass Bayou, Vicksburg, Miss.) and 6451 (Mint Spring Bayou, Vicksburg, Miss.) which seem rather to belong to this species than to *C. laevigata* D'Orbigny. The periphery has no keel and is lobulate, and the specimens are not so thick as most recent ones.

Family LAGENIDAE.

Genus LAGENA Walker and Boys, 1784.

Lagena laevigata (Reuss) Terrigi.

Fissurina laevigata Reuss, Akad. Wiss. Wien Denkschr., vol. 1, p. 366, pl. 46, fig. 1, 1849.

Lagena laevigata (Reuss) Terrigi, Accad. pont. Nuovi Lincei Atti, vol. 33, p. 177, pl. 1, fig. 6, 1880.

H. B. Brady, *Challenger* Rept., Zoology, vol. 9, p. 473, pl. 114, figs. 8 a, b, 1884.

Cushman, U. S. Nat. Mus. Bull. 71, pt. 3, p. 7, pl. 2, fig. 1, 1913.

Test subglobose, compressed, somewhat pyriform in front view, elliptical in cross section; wall smooth, transparent in thin specimens or opaque in more thickened ones, along the lateral margins usually clear, even in thickened specimens; aperture elongate, fairly narrow, connecting with the interior by a fairly long entosolenian neck. Length 0.45 millimeter.

A single specimen from station 6451 (Mint Spring Bayou, Vicksburg, Miss.) can be referred to this species. It is small and has the characteristic shape.

Lagena striata (D'Orbigny) Reuss var. substriata Williamson.

Plate XXIX, figure 10.

Lagena substriata Williamson, Annals and Mag. Nat. Hist., 2d ser., vol. 1, p. 15, pl. 2, fig. 12, 1848.

Lagena vulgaris var. *substriata* Williamson, Recent Foraminifera of Great Britain, p. 7, pl. 1, fig. 14, 1858.

Lagena striata (D'Orbigny) Reuss var. *substriata* Williamson. Cushman, U. S. Nat. Mus. Bull. 71, pt. 2, p. 20, pl. 8, figs. 1-3, 1913.

Variety differing from the typical species in the more elongate body, long tapering neck, costulate surface extending up onto the neck, often to its end, and usually spirally arranged on the neck. Length 0.4 to 0.5 millimeter.

A single very typical specimen of this variety was found at station 7671, "Brown's Cave," Leaf River, Miss. The neck is somewhat broken, but the general form of the test and the ornamentation are those of the variety.

Lagena orbignyana (Seguenza) H. B. Brady var. flintii
Cushman, n. var.

Plate XXIX, figure 11.

Lagena castrensis Flint (not Schwager), U. S. Nat. Mus. Ann. Rept. for 1897, p. 308, pl. 54, fig. 5, 1899.

Variety with a secondary keel at each side near the periphery and a series of two or three concentric lines of lacunae or pitted areas of uniform size inside the inner carina, the central part of the test being nearly smooth. Length 0.45 millimeter.

Type specimen from station 6447, Glass Bayou, Vicksburg, Miss. This is very similar to specimens from off the eastern coast of the United States figured by Flint, as cited above. The ornamentation is much more distinct on the peripheral portion than in the center, which is nearly smooth.

Lagena hexagona (Williamson) Siddall.

Plate XXIX, figure 12.

Entosolenia squamosa Montagu var. *hexagona* Williamson, Annals and Mag. Nat. Hist., 2d ser., vol. 1, p. 20, pl. 2, fig. 23, 1848; Recent Foraminifera of Great Britain, p. 13, pl. 1, fig. 31, 1858.

Lagena hexagona (Williamson) Siddall, Catalogue of British Recent Foraminifera, p. 6, 1879.

H. B. Brady, *Challenger* Rept., Zoology, vol. 9, p. 472, pl. 58, figs. 32, 33, 1884.

Cushman, U. S. Nat. Mus. Bull. 71, pt. 3, p. 17, pl. 6, figs. 2, 3, 1913.

Test subglobular, broadly rounded at the apical end, bluntly pointed at the apertural end, surface ornamentation consisting of a reticulate pattern, the areoles of which are hexagonal, either arranged in vertical rows or irregular. Length 0.5 millimeter.

The only record for this species in this lot of material is from station 6452, Mint Spring Bayou, Vicksburg, Miss. It is similar to the specimen I have figured.³

Genus NODOSARIA Lamarck, 1812.**Nodosaria communis D'Orbigny.**

Plate XXX, figure 4.

Nodosaria (Dentalina) communis D'Orbigny, Annales sci. nat., vol. 7, p. 254, No. 35, 1826.

Nodosaria communis H. B. Brady, *Challenger* Rept., Zoology, vol. 9, p. 504, pl. 62, figs. 19-22, 1884.

Cushman, U. S. Nat. Mus. Bull. 71, pt. 3, p. 54, pl. 28, figs. 1, 2, 1913.

Test elongate, slender, tapering, straight or more often slightly curved, composed of

numerous chambers, slightly inflated toward the apical end but later ones becoming more inflated; sutures oblique; aperture radiate, slightly eccentric, somewhat elongate; surface smooth. Length 3 millimeters or more.

Single specimens of this species were found at two stations:

6451. Mint Spring Bayou, Vicksburg, Miss.

7671. "Brown's Cave," Leaf River, Miss.

Nodosaria filiformis D'Orbigny.

Plate XXX, figures 1-3.

Nodosaria filiformis D'Orbigny, Annales sci. nat., vol. 7, p. 253, No. 14, 1826.

H. B. Brady, *Challenger* Rept., Zoology, vol. 9, p. 500, pl. 63, figs. 3-5, 1884.

Cushman, U. S. Nat. Mus. Bull. 71, pt. 3, p. 55, pl. 27, figs. 1-4, 1913.

Test elongate, slender, arcuate; chambers numerous, elliptical or ovate, elongate, tumid, sutures usually oblique; chambers increasing in length toward the apertural end; aperture radiate, slightly eccentric; wall smooth. Length 5 millimeters or less.

Specimens showing a few chambers which seem to belong to this species were collected at three stations:

6448. Glass Bayou, Vicksburg, Miss.

6451. Mint Spring Bayou, Vicksburg, Miss.

7671. "Brown's Cave," Leaf River, Miss.

They are elongate, cylindrical, and slightly contracted at the ends, and the apertural end, where shown, is long and tapering.

Nodosaria obliqua (Linnaeus) H. B. Brady.

Plate XXX, figures 6, 7.

Nautilus obliquus Linnaeus, Systema naturae, 10th ed., p. 711, 1758; 13th ed. (Gmelin's), p. 3372, No. 14, 1788.

Nodosaria obliqua (Linnaeus), H. B. Brady, *Challenger* Rept., Zoology, vol. 9, p. 513, pl. 64, figs. 20-22, 1884.

Cushman, U. S. Nat. Mus. Bull. 71, pt. 3, p. 59, pl. 25, fig. 5, 1913.

Nodosaria (Dentalina) obliqua (Linnaeus) Parker and Jones, Annals and Mag. Nat. Hist., 3d ser., vol. 3, p. 482, 1859.

Test elongate, tapering, apical end often with a spine; chambers numerous, in the early portion not distinct, in the later portion tumid; sutures depressed; surface ornamented with numerous rounded costae, fairly broad, as many as forty in the adult chambers of some of the specimens, costae continuous on the apical spine to the apertural end, additional ones added between those already formed;

³ Cushman, J. A., op. cit., pl. 6, fig. 2.

aperture radiate. Length as much as 10 millimeters when complete.

Specimens were present in material from the following stations:

6452. Mint Spring Bayou, Vicksburg, Miss.
 6647. Chickasawhay River 1¼ miles southwest of Boice, Miss.
 7671. "Brown's Cave," Leaf River, Miss.

This is quite possibly the same as the species from the Byram marl noted as a "single fragmentary specimen."⁴

Nodosaria sp.?

Plate XXX, figure 5.

There is a single specimen of *Nodosaria* from station 7671 ("Brown's Cave," Leaf River, Miss.) which may possibly be the young of *Nodosaria obliqua* but is here noted and figured that it may be on record for comparisons with forms from other horizons.

Genus **CRISTELLARIA** Lamarck, 1812.

Cristellaria convergens? Bornemann.

- Cristellaria convergens* Bornemann, Deutsch. geol. Gesell. Zeitschr., vol. 7, 1855, p. 327, pl. 13, figs. 16, 17.
 H. B. Brady, *Challenger* Rept., Zoology, vol. 9, p. 546, pl. 69, figs. 6, 7, 1884.
 Cushman, U. S. Nat. Mus. Bull. 71, pt. 3, p. 68, pl. 34, fig. 3, 1913.

Test oval, biconvex, closely coiled; chambers triangular, the last-formed one drawn out to a point at the apertural end; sutures hardly visible, the chambers embracing to the umbo; wall smooth and thick. Length about 1 millimeter.

Single specimens that seem to be at least questionably this species were found at two stations:

6647. Chickasawhay River 1¼ miles southwest of Boice, Miss.
 7671. "Brown's Cave," Leaf River, Miss.

Cristellaria rotulata (Lamarck) D'Orbigny.

Plate XXXII, figure 1.

- Lenticulites rotulata* Lamarck, Annales du Muséum, vol. 5, p. 188, No. 3, 1804; vol. 8, pl. 62, fig. 11, 1806.
Cristellaria rotulata (Lamarck) D'Orbigny, Soc. géol. France Mém., 1st ser., vol. 4, p. 26, pl. 2, figs. 16-18, 1840.
 H. B. Brady, *Challenger* Rept., Zoology, vol. 9, p. 547; pl. 69, figs. 13a, b, 1884.
 Cushman, U. S. Nat. Mus. Bull. 71, pt. 3, p. 66, pl. 35, fig. 3, 1913.

Test large, closely coiled; chambers numerous, lenticular, biconvex; wall smooth, thick; peripheral margin rather acute but not distinctly carinate; apertures of all chambers of visible test usually apparent. Length 1.5 to 2 millimeters.

Specimens that may be referred to this and the following species occurred in considerable numbers at station 7671, "Brown's Cave," Leaf River, Miss.

Cristellaria cultrata (Montfort) Parker and Jones.

Plate XXXI, figure 8.

- Robulus cultratus* Montfort?, Conchyliologie systématique, vol. 1, p. 214, 54^e genre, 1808.
Cristellaria cultrata (Montfort) Parker and Jones, Philos. Trans., vol. 155, p. 344, pls. 13, 17, 18; pl. 16, fig. 5, 1865.
 H. B. Brady, *Challenger* Rept., vol. 9, p. 550, pl. 70, figs. 4-6, 1884.
 Cushman, U. S. Nat. Mus. Bull. 71, pt. 3, p. 64, pl. 29, fig. 5, 1913.
Robulina cultrata (Montfort) D'Orbigny, Annales sci. nat., vol. 7, p. 287, No. 1, Modèles, No. 82, 1826; Foraminifères fossiles du bassin tertiaire de Vienne, p. 96, pl. 4, figs. 14, 15, 1846.

Test very similar to that of *C. rotulata*, but with the added character of a peripheral keel of greater or less extent. Diameter 2 millimeters or less.

Specimens that may be considered *C. cultrata*, having a broader keel and somewhat different shape, with fewer chambers than *C. rotulata*, occurred with that species at station 7671, "Brown's Cave," Leaf River, Miss.

Cristellaria vicksburgensis Cushman, n. sp.

Plate XXXI, figures 6, 7.

Test composed of few chambers, seven to eight in the visible coil; surface generally smooth, except on the sutures, which are marked by rather broad, curved, raised ridges, those near the earlier part of the coil broken into rounded knobs, especially near the umbilical area, the later ones more continuous; periphery angled, the early portion carinate; apertural face smooth and somewhat concave with acute projecting angles; aperture radiate at the angle of the chamber. Length 0.65 to 1 millimeter.

Type specimen from station 6647, Chickasawhay River 1¼ miles southwest of Boice,

⁴Cushman, J. A., U. S. Geol. Survey Prof. Paper 129, p. 93, 1922 (Prof. Paper 129-E).

Miss. This species was also found at station 7671, "Brown's Cave," Leaf River, Miss.

This is undoubtedly the same as the species found in the Byram marl and recorded without a specific name.⁵ It seems to be very constant in its characters and can be distinguished by the peculiar ornamentation, the uncoiling of the later portion of the test, and the concave apertural face.

Genus **VAGINULINA** D'Orbigny, 1826.

Vaginulina legumen (Linnaeus) D'Orbigny var. *elegans* (D'Orbigny) Fornasini.

Vaginulina legumen (Linnaeus) D'Orbigny var. *elegans* (D'Orbigny) Fornasini, Soc. geol. italiana Boll., vol. 5, p. 25, pl. 1, figs. 1², 2-8, 1886.

Cushman, U. S. Geol. Survey Prof. Paper 129, p. 93, pl. 17, fig. 1, 1922.

There is a single broken specimen of this variety from station 6447 (Glass Bayou, Vicksburg, Miss.), similar in form to that which I have seen from the Philippines. This has also been recorded from the Byram marl.

Genus **POLYMORPHINA** D'Orbigny, 1826.

Polymorphina byramensis Cushman.

Polymorphina byramensis Cushman, U. S. Geol. Survey Prof. Paper 129, p. 94, pl. 17, figs. 2a, 2b, 1922.

Test short and broad, triangular, composed of a few chambers, usually only four, all except a final fifth chamber extending back to the base of the proloculum, forming a truncate test; chambers inflated; sutures deep and distinct; surface smooth; aperture radiate, only slightly produced. Length 0.75 millimeter or less.

This species, which is common in the Byram marl, has been found at all the stations in the Mint Spring marl studied in this collection, as follows:

6447, 6448. Glass Bayou, Vicksburg, Miss.

6451, 6452. Mint Spring Bayou, Vicksburg, Miss.

6647. Chickasawhay River 1½ miles southwest of Boice, Miss.

7671. "Brown's Cave," Leaf River, Miss.

The specimens are very typical. A large proportion of them have three or four chambers with a triangular test, truncate at the base, the fifth chamber when present being added at a higher level.

⁵ Cushman, J. A., U. S. Geol. Survey Prof. Paper 129, p. 93, 1922 (Prof. Paper 129-E).

Polymorphina regina H. B. Brady, Parker, and Jones.

Plate XXX, figure 8.

Polymorphina regina H. B. Brady, Parker, and Jones, Linnean Soc. London Trans., vol. 27, p. 241, pl. 41, figs. 32a, b, 1870.

H. B. Brady, *Challenger* Rept., Zoology, vol. 9, p. 571, pl. 73, figs. 11-13, 1884.

Egger, K. bayer. Akad. Wiss. München Abh., Cl. 2, vol. 18, p. 310, pl. 9, figs. 45, 50, 51, 1893.

Millett, Roy. Micr. Soc. Jour., 1903, p. 265.

Bagg, Maryland Geol. Survey, Miocene, p. 478, pl. 133, fig. 7, 1904; U. S. Nat. Mus. Proc., vol. 34, p. 149, 1908.

Chapman, Quekett Micr. Club Jour., 2d ser., vol. 10, p. 132, pl. 10, fig. 4, 1907 [1909]; Roy. Soc. Victoria Proc., vol. 22, p. 281, 1910.

Cushman, U. S. Nat. Mus. Bull. 71, pt. 3, p. 91, pl. 41, figs. 6, 7, 1913.

Heron-Allen and Earland, Zool. Soc. London Trans., vol. 20, p. 673, 1915.

Cushman, U. S. Geol. Survey Bull. 676, p. 54, pl. 11, figs. 3, 4, 1918; U. S. Nat. Mus. Proc., vol. 56, p. 619, 1919; U. S. Geol. Survey Prof. Paper 129, pl. 18, fig. 4, 1922.

Test elongate, fusiform; chambers tumid, distinct, especially in the later portion; sutures deep; wall ornamented by numerous longitudinal costae, usually continuing unbroken across several chambers; aperture radiate, somewhat produced. Length 1 millimeter or less.

This species was found at three of the Mint Spring marl stations, as follows:

6448. Glass Bayou, Vicksburg, Miss.

6452. Mint Spring Bayou, Vicksburg, Miss.

7671. "Brown's Cave," Leaf River, Miss.

It also occurs in the Byram marl and has been recorded from the Miocene of the Coastal Plain of the United States, in the Calvert formation of Chesapeake Beach, Md. (Bagg), and the Duplin marl of Mayesville, S. C. (Cushman). It is a fairly common species in recent seas in the Indo-Pacific region.

Polymorphina problema D'Orbigny.

Polymorphina (Guttulina) problema D'Orbigny, Annales sci. nat., vol. 7, p. 266, No. 14, Modèles, No. 61, 1826.

Cushman, U. S. Geol. Survey Prof. Paper 129, p. 94, pl. 18, fig. 1, 1922.

Guttulina problema D'Orbigny, Foraminifères fossiles du bassin tertiaire de Vienne, p. 224, pl. 12, figs. 26-28, 1846.

Test elongate, fusiform, composed of few chambers, tumid; sutures slightly depressed;

apical end bluntly pointed, apertural end tapering; surface smooth; aperture radiate. Length 1 millimeter or less.

A few specimens have been collected in the Mint Spring marl at the following stations:

6452. Mint Spring Bayou, Vicksburg, Miss.
6647. Chickasawhay River $1\frac{1}{4}$ miles southwest of Boice, Miss.
7671. "Brown's Cave," Leaf River, Miss.

Polymorphina gibba D'Orbigny.

Polymorphina (Globulina) gibba D'Orbigny, Annales sci. nat., vol. 7, p. 226, No. 20, Modèles, No. 63, 1826.

Polymorphina gibba H. B. Brady, Parker, and Jones (part), Linnean Soc. London Trans., vol. 27, p. 216, pl. 39, figs. 2a-d, 1870.

H. B. Brady, *Challenger* Rept., Zoology, vol. 9, p. 561, pl. 71, figs. 12a, b, 1884.

Cushman, U. S. Nat. Mus. Bull. 71, pt. 3, p. 85, pl. 41, fig. 4, 1913; U. S. Geol. Survey Bull. 676, p. 11, pl. 2, fig. 4; p. 52, pl. 11, fig. 5, 1918; U. S. Geol. Survey Prof. Paper 129, p. 93, pl. 17, fig. 3, 1922.

Test rotund, in front view nearly circular, in end view broadly oval; chambers few, distinct; sutures distinct, but little if at all excavated; wall smooth and translucent; aperture slightly produced, radiate. Length 0.75 millimeter or less.

Very rotund specimens which are here referred to this species were found in the Mint Spring marl at the following stations:

6447. Glass Bayou, Vicksburg, Miss.
6451. Mint Spring Bayou, Vicksburg, Miss.
6647. Chickasawhay River $1\frac{1}{4}$ miles southwest of Boice, Miss.
7671. "Brown's Cave," Leaf River, Miss.

This species also occurs in the Byram marl, and I have recorded it from the Pliocene Caloosahatchee marl on Shell Creek, Fla., and from the Miocene Calvert formation at Chesapeake Beach, Md. (Bagg), and Duplin marl at Mayesville, S. C.

Polymorphina amygdaloides (Reuss) Reuss?

Globulina amygdaloides Reuss, Deutsch. geol. Gesell. Zeitschr., vol. 3, p. 82, pl. 6, fig. 47, 1851.

Polymorphina amygdaloides (Reuss) Reuss, Akad. Wiss. Wien Sitzungsber., vol. 18, p. 250, pl. 8, fig. 84, 1855.

H. B. Brady, *Challenger* Rept., Zoology, vol. 9, p. 560, pl. 71, fig. 13(?) , 1884.

Bagg, U. S. Nat. Mus. Proc., vol. 34, p. 148, 1908.

Cushman, U. S. Nat. Mus. Bull. 71, pt. 3, p. 85, pl. 41, fig. 5, 1913; U. S. Geol. Survey Prof. Paper 129, p. 95, pl. 18, figs. 2a, 2b, 1922.

Test elongate-oval, much compressed, composed of few chambers, which are elongate and narrow; sutures rather indistinct, not depressed; surface smooth; aperture somewhat produced. Length 0.65 millimeter or less.

Elongate specimens somewhat like those figured in the paper on the Byram marl were found in the Mint Spring marl at the following stations:

- 6447, 6448. Glass Bayou, Vicksburg, Miss.
6451, 6452. Mint Spring Bayou, Vicksburg, Miss.
7671. "Brown's Cave," Leaf River, Miss.

The specimens are very doubtfully identical with the species of Reuss.

Polymorphina equalis D'Orbigny.

Plate XXXI, figure 3.

Polymorphina equalis D'Orbigny, Annales sci. nat., vol. 7, p. 265, No. 13, 1826.

Polymorphina aequalis D'Orbigny, Foraminifères fossiles du bassin tertiaire de Vienne, p. 227, pl. 13, figs. 11, 12, 1846.

Polymorphina gibba var. *aequalis* H. B. Brady, Parker, and Jones, Linnean Soc. London Trans., vol. 27, p. 216, pl. 39, figs. 2c, d, 1870.

Test compressed, broadly oval; periphery rather evenly curved, rounded, composed of few chambers; sutures distinct but very slightly depressed; wall smooth; aperture radiate. Length 0.7 to 0.8 millimeter.

This species described by D'Orbigny occurs sparsely in the Mint Spring marl at two stations:

6448. Glass Bayou, Vicksburg, Miss.
6451. Mint Spring Bayou, Vicksburg, Miss.

Polymorphina advena Cushman, n. sp.

Plate XXXI, figure 4.

Test much compressed, broadly ovate; chambers numerous, elongate, alternating, much the broadest near the peripheral end; sutures slightly depressed; surface ornamented with numerous fine longitudinal costae, except the last-formed one of two chambers, which are smooth, at least at the apertural end; aperture radiate. Length 1 millimeter.

Type specimen from station 6451, Mint Spring Bayou, Vicksburg, Miss.

This species is an unusual one for this genus, appearing much more like a *Bolivina*, but it has the characteristic aperture of *Polymorphina*. It is perhaps closest related to *Polymorphina complanata* D'Orbigny.

Polymorphina cuspidata H. B. Brady.

Plate XXX, figures 9, 10.

Polymorphina sororia Reuss var. *cuspidata* H. B. Brady, *Challenger Rept.*, p. 563, pl. 71, figs. 17-19; pl. 72, fig. 4, 1884.

Test elongate, fusiform, composed of a few chambers, initial end with a prominent sharp, elongate spine, apertural end bluntly pointed; surface smooth; sutures somewhat depressed; aperture radiate. Length 1.5 millimeters or less.

There are several specimens from station 6447 (Glass Bayou, Vicksburg, Miss.) which are very close to this form as figured by Brady in the *Challenger* report. The relation of this form to *P. sororia* Reuss seems very problematic, and I have given it specific rank. It is also represented in the Mint Spring marl by the variety described below.

Polymorphina cuspidata H. B. Brady var. costulata Cushman, n. var.

Plate XXXI, figure 1.

Variety differing from the typical species in the surface ornamentation, which consists of a few longitudinal costae, rather widely separated from each other.

Type specimen from station 6452, Mint Spring Bayou, Vicksburg, Miss.

Polymorphina vicksburgensis Cushman, n. sp.

Plate XXXI, figure 2.

Test elongate, fusiform, broadest near the initial end, which is subcircular in transverse section, the later portion becoming compressed and narrower, initial end bluntly pointed, or with a short spine; chambers becoming shorter toward the apertural ends in the adult; surface smooth, or with very slight longitudinal costae; sutures not depressed but often standing out as clearer areas in side view; aperture radiate. Length 1.5 millimeters or less.

Type specimen from station 6451, Mint Spring Bayou, Vicksburg, Miss. This species occurs also at station 6448, Glass Bayou, Vicksburg, Miss.

This seems to be different from the other described species of this genus and may be distinguished especially by the cuspidate initial end and the peculiar change in shape from the rounded early portion to the narrow, compressed last-formed portion.

Polymorphina spinosa (D'Orbigny) Egger.

Plate XXXI, figure 5.

Globulina spinosa D'Orbigny, *Foraminifères fossiles du bassin tertiaire de Vienne*, p. 230, pl. 13, figs. 23, 24, 1846.

Polymorphina spinosa (D'Orbigny) Egger, *Neues Jahrb.*, 1857, p. 292, pl. 14, figs. 9, 10,

H. B. Brady, Parker, and Jones, *Linnean Soc. London Trans.*, vol. 27, p. 243, pl. 42, figs. 36a, b, 1870.

Test rounded, irregular; chambers few; surface covered with numerous short, projecting spines which seem to be hollow where broken. Length 1 millimeter or less.

Rare specimens were obtained at the following stations:

6447. Glass Bayou, Vicksburg, Miss.

6451. Mint Spring Bayou, Vicksburg, Miss.

6647. Chickasawhay River $1\frac{1}{4}$ miles southwest of Boice, Miss.

7671. "Brown's Cave," Leaf River, Miss.

This species was originally described by D'Orbigny from specimens collected in the Vienna Basin, and the specimens from the Mint Spring marl, except that they are more irregular in form, agree at least in the ornamentation of the surface.

Genus UVIGERINA D'Orbigny, 1826.**Uvigerina byramensis Cushman.**

Uvigerina byramensis Cushman, *U. S. Geol. Survey Prof. Paper* 129, p. 95, pl. 18, fig. 5, 1922.

Test minute, elongate, somewhat fusiform, initial end pointed; chambers numerous, distinct; sutures depressed; surface ornamented by longitudinal costae, rather thin and sharp; the last-formed chamber more distinct than the rest, the inner side concave, the other two sides slightly convex, giving a generally triangular section, the surface of the last-formed chamber smooth; the apertural end produced into a short cylindrical neck with a slight lip, the aperture circular. Length 0.25 to 0.40 millimeter.

This species, originally described from specimens collected in the Byram marl, has been found at all but one of the stations in the Mint Spring marl, as follows:

6447. Glass Bayou, Vicksburg, Miss.

6451, 6452. Mint Spring Bayou, Vicksburg, Miss.

6647. Chickasawhay River $1\frac{1}{4}$ miles southwest of Boice, Miss.

7671. "Brown's Cave," Leaf River, Miss.

The characters that distinguish this species seem to be very constant, and the last-formed

chambers, especially where they are not close-set, have the distinct triangular shape which characterizes the type specimens.

Uvigerina pigmea D'Orbigny.

Plate XXXII, figure 2.

Uvigerina pigmea D'Orbigny, *Annales sci. nat.*, vol. 7, p. 269, pl. 12, figs. 8, 9, Modèles, No. 67, 1826.

Uvigerina pugnata D'Orbigny, *Foraminifères fossiles du bassin tertiaire de Vienna*, p. 190, pl. 11, figs. 25, 26, 1846.

H. B. Brady, *Challenger Rept.*, *Zoology*, vol. 9, p. 575, pl. 74, figs. 11-14, 1884.

Cushman, *U. S. Nat. Mus. Bull.* 71, pt. 3, p. 96, pl. 42, fig. 1; pl. 44, fig. 5, 1913; *U. S. Nat. Mus. Bull.* 103, p. 63, pl. 22, fig. 4, 1918; *U. S. Geol. Survey Bull.* 676, p. 55, 1918.

Test subcylindrical, triserially spiral; chambers numerous, inflated; sutures deep; wall ornamented by numerous longitudinal costae, those of each chamber usually independent of those of adjacent chambers; aperture with a short cylindrical neck and phialine lip. Length 0.75 to 1 millimeter.

Specimens that may be referred to this species were found at the following stations:

6447. Glass Bayou, Vicksburg, Miss.

6452. Mint Spring Bayou, Vicksburg, Miss.

6647. Chickasawhay River 1½ miles southwest of Boice, Miss.

7671. "Brown's Cave," Leaf River, Miss.

It has occurred in the Miocene of Maryland (Bagg), and in the St. Marys (?) formation in a well at Norfolk, Va. (depth 645 feet). I have also recorded it from the Culebra formation of the Canal Zone, and it may occur in the Miocene of the Gatun formation of the Canal Zone.

Family GLOBIGERINIDAE.

Genus GLOBIGERINA D'Orbigny, 1826.

***Globigerina bulloides* D'Orbigny.**

Globigerina bulloides D'Orbigny, *Annales sci. nat.*, vol. 7, p. 277, No. 1, Modèles, Nos. 17 and 76, 1826.

H. B. Brady, *Challenger Rept.*, *Zoology*, vol. 9, p. 593, pl. 77; pl. 79, figs. 3-7, 1884.

Cushman, *U. S. Nat. Mus. Bull.* 71, pt. 4, p. 5, pl. 2, figs. 7-9; pl. 9, 1914; *U. S. Nat. Mus. Bull.* 103, p. 64, 1918; *U. S. Geol. Survey Bull.* 676, p. 12, pl. 3, fig. 2; p. 56, pl. 3, figs. 4, 6, 1918; *Carnegie Inst. Washington Pub.* 291, p. 38, 1919; *U. S. Geol. Survey Prof. Paper* 129, p. 95, pl. 19, figs. 1-3, 1922.

Test subglobose, spiral, made up of a few inflated chambers, all visible from the dorsal side, three to four visible from the ventral side; sutures deep, surface reticulate.

This common species, which has been recorded in the Pliocene, Miocene, and Oligocene, occurs in the Mint Spring marl at four stations, as follows:

6447. Glass Bayou, Vicksburg, Miss.

6451, 6452. Mint Spring Bayou, Vicksburg, Miss.

7671. "Brown's Cave," Leaf River, Miss.

***Globigerina dutertrei* D'Orbigny.**

Globigerina dutertrei D'Orbigny, in De la Sagra, *Histoire physique, politique et naturelle de l'île de Cuba*, *Foraminifères*, p. 95, pl. 4, figs. 19-21, 1839.

H. B. Brady, *Challenger Rept.*, *Zoology*, vol. 9, p. 601, pl. 81, figs. 1a-c, 1884.

Cushman, *U. S. Nat. Mus. Bull.* 71, pt. 4, p. 8, 1914.

Test rounded, the dorsal side slightly convex, the ventral side more strongly convex, composed of about three whorls, the last one consisting of four to five chambers, much inflated, especially the later ones, umbilicate; aperture comparatively small, a single arched opening near the umbilical edge of the last-formed chamber. Diameter 0.60 millimeter or less.

Specimens apparently belonging to this species, which D'Orbigny described from material collected in the West Indies, occurred at three stations, as follows:

6451. Mint Spring Bayou, Vicksburg, Miss.

6647. Chickasawhay River 1½ miles southwest of Boice, Miss.

7671. "Brown's Cave," Leaf River, Miss.

Family ROTALIIDAE.

Genus SPIRILLINA Ehrenberg, 1841.

***Spirillina limbata* H. B. Brady var. *bipunctata* Cushman, n. var.**

Plate XXXII, figures 3-5.

Test very similar in general to that of *Spirillina limbata* but differing in the character of the ornamentation, the area of the dorsal surface being ornamented in the adult of this variety by a double series of deep punctations inside the raised carina.

Type specimen from station 6647, Chickasawhay River 1½ miles southwest of Boice, Miss. This variety is also present in the Mint Spring marl at the following stations:

6447. Glass Bayou, Vicksburg, Miss.

6451, 6482. Mint Spring Bayou, Vicksburg, Miss.

7671. "Brown's Cave," Leaf River, Miss.

In recent seas *S. limbata* is known from the Pacific, being one of the forms that are characteristic of the Indo-Pacific region, and it is also

characteristic of the lower Oligocene of the Coastal Plain of the United States.

The young of this species has only a single row of pits, becoming double in the adult. The ornamentation of the ventral side is shown in figure 5.

Genus **PATELLINA** Williamson, 1858.

Patellina advena Cushman, n. sp.

Plate XXXI, figure 9.

Test plano-convex, early portion composed of chambers spirally arranged, later ones elongate and becoming nearly annular; chambers partly divided by numerous longitudinal internal septa, visible from the exterior, forming what seems to be a radiating pattern; ventral side with numerous radiating lines. Diameter 0.4 millimeter.

Type specimen from station 6452, Mint Spring Bayou, Vicksburg, Miss.

This species differs from *Patellina corrugata* Williamson in the much finer division by internal septa. The spire is low, making a broad, flaring test.

Genus **DISCORBIS** Lamarck, 1804.

Discorbis auracana (D'Orbigny) Cushman.

Plate XXXII, figure 6.

Rosalina auracana D'Orbigny, Voyage dans l'Amérique méridionale, Foraminifères, p. 41, pl. 6, figs. 16-18, 1839.

Discorbis auracana (D'Orbigny) Cushman, U. S. Nat. Mus. Bull. 71, pt. 3, p. 15, pl. 9, fig. 3; fig. 15 (in text).

Discorbina auracana (D'Orbigny) Parker and Jones, Geol. Soc. London Quart. Jour., vol. 28, p. 115, 1872.

H. B. Brady, *Challenger* Rept., Zoology, vol. 9, p. 615, pl. 86, figs. 10, 11, 1884.

Test small, plano-convex, dorsal side slightly convex, ventral side flat or slightly concave, peripheral margin rather acutely rounded; chambers six to nine in the last-formed whorl; sutures slightly depressed, often limbate with clear shell material; early chambers often carinate with similar material; wall finely punctate; aperture a narrow curved slit at the margin of the ventral side of the chamber; color brownish, especially in the earlier chambers. Diameter 0.3 to 0.5 millimeter.

Specimens that are referred to this species were rare at a single station, 6447, Glass Bayou, Vicksburg, Miss. The sutures are limbate, and the last-formed chamber has a projecting lip above the aperture.

Discorbis bertheloti (D'Orbigny) Cushman.

Plate XXXII, figure 7.

Rosalina bertheloti D'Orbigny, in Barker, Webb, and Berthelot, Histoire naturelle des îles Canaries, vol. 2, pt. 2, Foraminifères, p. 135, pl. 1, figs. 28-30, 1839.

Discorbis bertheloti (D'Orbigny) Cushman, U. S. Nat. Mus. Bull. 71, pt. 3, p. 20, pl. 7, fig. 3, 1913; U. S. Geol. Survey Bull. 676, p. 58, pl. 15, figs. 1-3, 1918.

Discorbina bertheloti (D'Orbigny) H. B. Brady, Linnean Soc. London Trans., vol. 24, p. 469, pl. 48, figs. 10a, b, 1864; *Challenger* Rept., Zoology, vol. 9, p. 650, pl. 89, figs. 10-12, 1884.

Test unequally biconvex, usually six to seven chambers in the last-formed coil, dorsal side usually flattened, ventral side more convex; sutures curved, fairly distinct on both sides, occasionally slightly limbate; aperture usually extending into the dorsal side so that a portion of the aperture is peripheral. Diameter 0.80 millimeter or less.

This species occurs at two Mint Spring marl stations:

6451, 6452, Mint Spring Bayou, Vicksburg, Miss.

I have also recorded it from the Miocene of the Coastal Plain in the Choctawhatchee marl 1 mile south of Red Bay, Fla.; in the Duplin marl (?) of South Carolina (locality unknown); and in the Yorktown formation at Suffolk, Va.

Genus **TRUNCATULINA** D'Orbigny, 1826.

Truncatulina lobatula (Walker and Jacob) D'Orbigny.

Nautilus lobatulus Walker and Jacob, Adams's Essays on the microscope, Kammacher's ed., p. 612, pl. 14, fig. 36, 1798.

Truncatulina lobatula (Walker and Jacob) D'Orbigny, in Barker, Webb, and Berthelot, Histoire naturelle des îles Canaries, vol. 2, pt. 2, Foraminifères, p. 134, pl. 2, figs. 22-24, 1839; Foraminifères fossiles du bassin tertiaire de Vienne, p. 168, pl. 9, figs. 18-23, 1846.

H. B. Brady, *Challenger* Rept., Zoology, vol. 9, p. 660, pl. 92, fig. 10; pl. 93, fig. 1, 1884.

Cushman, U. S. Geol. Survey Bull. 676, p. 16, pl. 1, fig. 10; p. 60, pl. 17, figs. 1-3; U. S. Geol. Survey Prof. Paper 129, p. 26, pl. 20, figs. 1-3, 1922.

Test plano-convex, flattened on the ventral face, moderately convex dorsally, peripheral margin rounded; chambers numerous, seven or eight in the last-formed whorl; sutures depressed, especially on the dorsal face; wall smooth, punctate.

Specimens were obtained at five of the six Mint Spring marl stations, as follows:

6448. Glass Bayou, Vicksburg, Miss.
 6451, 6452. Mint Spring Bayou, Vicksburg, Miss.
 6647. Chickasawhay River $1\frac{1}{4}$ miles southwest of Boice, Miss.
 7671. "Brown's Cave," Leaf River, Miss.

This species is common both in the Tertiary and in the present oceans. I have recorded it from the Pliocene and the Miocene of the Coastal Plain of the United States and the Oligocene (Byram marl) at Byram, Miss.

Truncatulina byramensis Cushman.

Truncatulina byramensis Cushman, U. S. Geol. Survey Prof. Paper 129, p. 96, pl. 20, figs. 4-6, 1922.

Test plano-convex, dorsal side slightly convex, ventral side flattened, peripheral margin subcarinate; about eight chambers in the last-formed whorl, chambers on the ventral side failing to reach the center of the test, leaving a definite umbilical area, which is filled with clear shell material; on the dorsal side each chamber at its inner border has the angles somewhat produced and a broad, rounded reentrant near the middle; on the ventral side the inner half of the chamber is rather intricately lobed, the chambers themselves of lighter color; the sutures darker, of clear shell material; surface finely granular; aperture an elongate opening at the base of the last-formed chamber near its inner ventral border. Diameter 0.35 to 0.75 millimeter.

Specimens of this species were collected at the following stations:

- 6451, 6452. Mint Spring Bayou, Vicksburg, Miss.
 6447, 6448. Glass Bayou, Vicksburg, Miss.

This species was described from specimens obtained in the Byram marl, where it is common. It is a peculiar species, easily distinguished by the unusual lobed chambers.

Truncatulina americana Cushman var.

Truncatulina americana Cushman, U. S. Geol. Survey Bull. 676, p. 63, pl. 20, figs. 2, 3; pl. 21, fig. 1, 1918; U. S. Nat. Mus. Bull. 103, p. 68, pl. 23, figs. 2 a-c, 1918; U. S. Geol. Survey Prof. Paper 129, p. 97, pl. 20, figs. 7, 8, 1922.

Test plano-convex, dorsal side nearly flat, ventral side slightly convex; chambers numerous, ten to fifteen in the last-formed coil, rather rapidly increasing in size, peripheral margin subangular, dorsal side with the last few chambers failing to meet the umbilicus, ventral side

similar in this respect in most specimens; sutures distinct, slightly limbate on the dorsal side, depressed on the ventral side; wall smooth, punctate, aperture peripheral with a slight lip. Diameter 0.75 millimeter or less.

Small specimens of this species with a slightly broader form than the typical occur in the Mint Spring marl at the following stations:

- 6447, 6448. Glass Bayou, Vicksburg, Miss.
 6451, 6452. Mint Spring Bayou, Vicksburg, Miss.

This species is found in the Miocene and Oligocene of the Coastal Plain and in the upper Oligocene of the Canal Zone.

Truncatulina pseudoungeriana Cushman.

Truncatulina ungeriana H. B. Brady (not *Rotalina ungeriana* D'Orbigny, 1826), *Challenger Rept.*, Zoology, vol. 9, pl. 94, figs. 9 a-c, 1884.

Cushman, U. S. Nat. Mus. Bull. 103, p. 69, pl. 24, fig. 1, 1918.

Truncatulina pseudoungeriana Cushman, U. S. Geol. Survey Prof. Paper 129, p. 97, pl. 20, fig. 9, 1922.

Test biconvex, almost equally so, periphery subacute; chambers nine to eleven in the last-formed whorl, those of the earlier whorls not showing on either the ventral or the dorsal side, on the dorsal because they are hidden by the roughness of the surface, and on the ventral because of the involute character; periphery lobulate; sutures distinct above in the last whorl and very distinct below, as the sutures are somewhat tumid on the ventral side; umbilical region filled nearly flush with the chambers by clear shell material, last few chambers on the dorsal side slightly above the surface on the inner margin; surface dorsally with coarse punctae, below smooth and more finely punctate; aperture at the periphery. Diameter 1 millimeter or less.

Specimens of this species were common in the Mint Spring marl at station 6647, Chickasawhay River $1\frac{1}{2}$ miles southwest of Boice, Miss. It occurred more rarely at the following stations:

6447. Glass Bayou, Vicksburg, Miss.
 6451. Mint Spring Bayou, Vicksburg, Miss.
 7671. "Brown's Cave," Leaf River, Miss.

Truncatulina vicksburgensis Cushman, n. sp.

Plate XXXV, figures 7, 8.

Test plano-convex, dorsal side with the sutures very obscure, low-spined, periphery subacute, ventral side with a central raised area and the inner angle of each chamber ending in a raised knob, ventral side of the cham-

bers somewhat irregularly granular, especially toward the inner margin; otherwise the chambers are not distinct from one another. Diameter 0.50 to 0.60 millimeter.

Type specimen from station 6448, Glass Bayou, Vicksburg, Miss.

This differs from the other species of the genus found in the lower Oligocene of the Coastal Plain in its form, its indistinct chambers, and the peculiar ornamentation of the ventral side.

Genus ANOMALINA D'Orbigny, 1826.

***Anomalina bilateralis* Cushman.**

Anomalina bilateralis Cushman, U. S. Geol. Survey Prof. Paper 129, p. 97, pl. 21, figs. 1, 2, 1922.

Test of about four coils, bilateral or nearly so, composed of numerous chambers, ten or more in the last-formed whorl, umbilical region on both sides with a knob of clear shell material, more pronounced on the dorsal side; chambers smooth but coarsely punctate, more coarsely so on the ventral side; sutures broad and somewhat limbate with clear shell material; aperture a narrow curved opening at the base of the final chamber. Diameter 1 millimeter or less.

This is one of the species described from specimens collected in the Byram marl, where it was rare, at least at the type station. In the Mint Spring marl it occurred sparsely at the following stations:

6448. Glass Bayou, Vicksburg, Miss.

6451. Mint Spring Bayou, Vicksburg, Miss.

6647. Chickasawhay River 1½ miles southwest of Boice, Miss.

7671. "Brown's Cave," Leaf River, Miss.

***Anomalina mississippiensis* Cushman.**

Anomalina mississippiensis Cushman, U. S. Geol. Survey Prof. Paper 129, p. 98, pl. 21, figs. 6-8, 1922.

Test small, plano-convex, of about two and one-half coils, periphery slightly lobulate, bluntly rounded, dorsal side very much flattened, even slightly concave, ventral side very convex; chambers comparatively few, six to eight in the last-formed coil; sutures curved, on the dorsal side broad and limbate, even with the surface of clear shell material, on the ventral side narrower and depressed; the last-formed two or three chambers on the inner margin on the dorsal side slightly above the general surface; wall thin and translucent, especially on the dorsal side, smooth; on the

ventral finely punctate and not so clear; aperture a curved opening at the inner margin at the periphery. Length 0.25 to 0.35 millimeter; breadth 0.20 to 0.30 millimeter.

This small species is fairly common in the Byram marl and is common in the Mint Spring marl at all the stations, as follows:

6447, 6448. Glass Bayou, Vicksburg, Miss.

6451, 6452. Mint Spring Bayou, Vicksburg, Miss.

6647. Chickasawhay River 1½ miles southwest of Boice, Miss.

7671. "Brown's Cave," Leaf River, Miss.

***Anomalina vicksburgensis* Cushman, n. sp.**

Plate XXXV, figures 5, 6.

Test unequally biconvex, dorsal side more flattened than the ventral; chambers numerous, ten to twelve in the last-formed coil; sutures slightly limbate; periphery rounded, not lobulate; wall between the sutures finely granular or punctate, ventral side with a clear mass of shell material at the umbilicus. Diameter 0.35 millimeter.

Type specimen from station 6452, Mint Spring Bayou, Vicksburg, Miss. This is a peculiar species of the genus; it is rare at the type station and was not found in any other Mint Spring material.

Genus SIPHONINA Reuss, 1849.

***Siphonina advena* Cushman.**

Siphonina advena Cushman, U. S. Geol. Survey Prof. Paper 129, p. 98, pl. 22, figs. 1-2, 1922.

Test unequally biconvex, dorsal side usually less convex than the ventral; periphery subacute; chambers in three or more coils, four chambers making up the last-formed coil; sutures distinct, on the dorsal side flush with the surface, on the ventral side slightly depressed, on the dorsal side somewhat broadened and limbate, ventrally narrow; surface smooth but punctate; aperture with a short neck, compressed, with a phialine lip and elliptical aperture; color, even in the fossil specimens, somewhat brownish; wall thin and translucent. Diameter 0.50 millimeter or less.

Specimens of this species occurred at all six of the Mint Spring marl stations, as follows:

6447, 6448. Glass Bayou, Vicksburg, Miss.

6451, 6452. Mint Spring Bayou, Vicksburg, Miss.

6647. Chickasawhay River 1½ miles southwest of Boice, Miss.

7671. "Brown's Cave," Leaf River, Miss.

It was common in the marl at Byram, Miss.

Genus *GYPSINA* Carter, 1877.*Gypsina rubra* (D'Orbigny) Heron-Allen and Earland.

Planorbulina rubra D'Orbigny, *Annales sci. nat.*, vol. 7, p. 280, No. 4, 1826.

Fornasini, *Accad. sci. Ist. Bologna Mem.*, 6th ser., vol. 5, p. 44, pl. 2, fig. 3, 1908.

Gypsina rubra (D'Orbigny) Heron-Allen and Earland, *Zool. Soc. London Trans.*, vol. 20, p. 725; pl. 53, figs. 35-37, 1915.

Cushman, U. S. Geol. Survey Prof. Paper 129, p. 98, pl. 22, fig. 3, 1922.

This species, recorded from the Byram marl, has also been found at three of the stations in the Mint Spring marl, as follows:

6452. Mint Spring Bayou, Vicksburg, Miss.

6647. Chickasawhay River $1\frac{1}{4}$ miles southwest of Boice, Miss.

7671. "Brown's Cave," Leaf River, Miss.

This is a species from the Indo-Pacific which occurs in the lower Oligocene of the Coastal Plain of the United States.

Genus *PULVINULINA* Parker and Jones, 1862.*Pulvinulina byramensis* Cushman.

Pulvinulina byramensis Cushman, U. S. Geol. Survey Prof. Paper 129, p. 99, pl. 22, figs. 4, 5, 1922.

Test small, biconvex, rotaliform, consisting of about three coils, seven to eight chambers in the last-formed coil; on the dorsal side sutures oblique and at a considerable angle with the periphery, somewhat limbate; on the ventral side the chambers extend in to the center, which is usually not umbilicate; sutures nearly straight; surface polished, punctations appearing as light tubules against the translucent wall; aperture near the inner end of the chamber on the ventral side with a definite valvular lip, the aperture hidden below but when examined found to be composed, in the adult, of several adjacent small rounded openings. Diameter 1.5 millimeters or less.

This species, which was described from abundant specimens obtained in the Byram marl at Byram, Miss., has occurred at all six of the stations in the Mint Spring marl, as follows:

6447, 6448. Glass Bayou, Vicksburg, Miss.

6451, 6452. Mint Spring Bayou, Vicksburg, Miss.

6647. Chickasawhay River $1\frac{1}{4}$ miles southwest of Boice, Miss.

7671. "Brown's Cave," Leaf River, Miss.

At many of these stations it is common and corresponds closely to the description given above.

Pulvinulina glabrata Cushman.

Pulvinulina glabrata Cushman, U. S. Geol. Survey Prof. Paper 129, p. 99, pl. 22 figs. 6, 7, 1922.

Test biconvex, elongate, somewhat lobulate, composed of about two coils, seven chambers in the last-formed one, dorsal side convex; sutures depressed, curved; chambers convex between, rapidly increasing in size as added; dorsal side very coarsely punctate, the sutures somewhat limbate, ventral side umbilicate; surface smooth and with very fine punctations; sutures distinct; last-formed chamber with a long, straight valvular lip across the whole of the depressed umbilicus; aperture beneath the lip. Length 0.5 millimeter.

This species, which was rare in the marl at Byram, Miss., has been found at four of the stations in the Mint Spring marl, as follows:

6448. Glass Bayou, Vicksburg, Miss.

6451, 6452. Mint Spring Bayou, Vicksburg, Miss.

7671. "Brown's Cave," Leaf River, Miss.

It is in some ways related to the species described and figured by Brady in the *Challenger* report as *Discorbina ventricosa* H. B. Brady. It is more elongate than that form, and the last-formed chamber especially gives it an entirely different shape. It is one of the most striking species in this lower Oligocene material.

Genus *ROTALIA* Lamarek, 1804.*Rotalia byramensis* Cushman.

Rotalia byramensis Cushman, U. S. Geol. Survey Prof. Paper 129, p. 99, pl. 23, fig. 1, 1922.

Test unequally biconvex, rotaliform, in the last-formed coil six to seven chambers, dorsally with the chambers somewhat triangular; sutures oblique, limbate, broad, of clear shell material; ventral side with a large circular mass in the umbilical region, with the sutures deep and ending in a depressed ring about it; aperture with a somewhat valvular lip, often divided into several teeth; surface on the dorsal side somewhat roughened, on the ventral side scrobiculate near the periphery, smoother near the center. Diameter 2 millimeters or less.

Specimens that may be referred to this species were found at stations 6447 and 6448, Glass Bayou, Vicksburg, Miss.

The species is perhaps closest to *Rotalia armata* D'Orbigny. The chambers are triangular, and where there is a spinose projection it is at the angle rather than at the middle portion of the chamber, as in *R. armata*.

Rotalia dentata Parker and Jones var. *parva* Cushman, n. var.

Plate XXXV, figures 1, 2.

Variety differing from the typical species in the size and the number of chambers, having usually but five chambers in the last-formed coil, each with a single spine from the periphery at the center of each chamber. Diameter 0.65 millimeter.

Type specimen from station 6451, Mint Spring Bayou, Vicksburg, Miss. This also occurs at the following stations:

- 6447, 6448. Glass Bayou, Vicksburg, Miss. .
6452. Mint Spring Bayou, Vicksburg, Miss.

Rotalia vicksburgensis Cushman, n. sp.

Plate XXXV, figures 3, 4.

Test spiral, dorsal side flattened, ventral side strongly convex, umbilicate, about eight chambers in the last-formed coil; chambers distinct, inflated; sutures distinct, slightly depressed; surface smooth, finely punctate. Diameter 0.75 millimeter or less.

Type specimens from station 6647, Chickasawhay River 1¼ miles southwest of Boice, Miss. It also occurred at the following stations:

6448. Glass Bayou, Vicksburg, Miss.
6451, 6452. Mint Spring Bayou, Vicksburg, Miss.
7671. "Brown's Cave," Leaf River, Miss.

This species is apparently related to *R. soldanii* D'Orbigny, but it does not have nearly so great a height, the line between adjacent whorls is not channeled, and in general it has a much more primitive form.

Family NUMMULITIDAE.

Genus NONIONINA D'Orbigny, 1826.

Nonionina umbilicatula (Montagu) Parker, Jones, and H. B. Brady.

Nautilus umbilicatulus Montagu, Testacea Britannica, p. 191, 1803; Suppl., p. 78, pl. 18, fig. 1, 1808.

Nomionna umbilicatula (Montagu) Parker, Jones, and H. B. Brady, Annals and Mag. Nat. Hist., 4th ser., vol. 8, p. 242, pl. 12, fig. 157, 1871.

H. B. Brady, *Challenger* Rept., Zoology, vol. 9, p. 726, pl. 109, figs. 8, 9, 1884.

Cushman, U. S. Geol. Survey Prof. Paper 129, p. 100, pl. 23, figs. 3, 4, 1922.

Test biconvex, peripheral margin rounded; chambers ten or more in the last-formed coil; sutures limbate but not depressed, deep,

umbilicate; wall smooth, punctate toward the periphery; aperture a very narrow curved opening at the base of the chamber, peripheral. Diameter 0.5 to 0.6 millimeter.

Specimens that may be referred to this species occurred at all but one of the Mint Spring marl stations, as follows:

- 6447, 6448. Glass Bayou, Vicksburg, Miss.
6452. Mint Spring Bayou, Vicksburg, Miss.
6647. Chickasawhay River 1¼ miles southwest of Boice, Miss.
7671. "Brown's Cave," Leaf River, Miss.

Specimens were not common, however, at any of these stations. I have already recorded the species from the Miocene near Centerville, Md.

Nonionina scapha (Fichtel and Moll) Parker and Jones.

Nautilus scapha Fichtel and Moll, Testacea microscopica, p. 105, pl. 19, figs. d-f, 1803.

Nonionina scapha (Fichtel and Moll), Parker and Jones, Annals and Mag. Nat. Hist., 3d ser., vol. 5, p. 102, No. 4, 1860.

H. B. Brady, *Challenger* Rept., Zoology, vol. 9, p. 730, pl. 109, figs. 14, 15, 16?, 1884.

Cushman, U. S. Nat. Mus. Bull. 103, p. 73, pl. 25, figs. 6a, b, 1918; U. S. Geol. Survey Prof. Paper 129, p. 100, pl. 23, figs. 5-7, 1922.

Test in side view longer than wide, about ten chambers in the last-formed coil, rapidly increasing in length as added; sutures evenly curved, slightly depressed; periphery broadly rounded, in apertural view the face of the last-formed chamber making up a large part of the visible surface; wall smooth, finely punctate, somewhat umbilicate; aperture an arched slit at the base of the chamber. Length 0.60 millimeter.

Specimens of this species were more common than those of *N. umbilicatula*. They occurred at all but one of the stations in the Mint Spring marl, as follows:

- 6447, 6448. Glass Bayou, Vicksburg, Miss.
6451, 6452. Mint Spring Bayou, Vicksburg, Miss.
7671. "Brown's Cave," Leaf River, Miss.

I have recorded the species as occurring in the Gatun formation of the Canal Zone.

Nonionina advena Cushman, n. sp.

Plate XXXII, figure 8.

Test small, circular in side view, biconvex; periphery rounded, nine to eleven chambers in the last-formed coil, inflated; sutures curved,

slightly sigmoid, the inner portion excavated and broadened; umbilical region at each side of the test occupied by a large projecting knob of clear shell material; aperture at the base of the last-formed chamber. Diameter 0.75 millimeter or less.

Type specimen from station 6647, Chickasawhay River $1\frac{1}{4}$ miles southwest of Boice, Miss. It also occurred at station 6447, Glass Bayou, Vicksburg, Miss.

This is an unusual form and may perhaps not belong to the genus *Nonionina*. It seems more like some species of *Polystomella*, but there appear to be no retral processes.

Family MILIOLIDAE.

Genus **CORNUSPIRA** Schultz, 1854.

Cornuspira involvens (Reuss) Reuss.

Operculina involvens Reuss, Akad. Wiss. Wien Denkschr., vol. 1, p. 370, pl. 45, fig. 30, 1849.

Cornuspira involvens (Reuss) Reuss, Akad. Wiss. Wien Sitzungsber., vol. 48, p. 39, pl. 1, fig. 2, 1863 (1864).
H. B. Brady, *Challenger* Rept., Zoology, vol. 9, p. 200, pl. 11, figs. 1-3, 1884.

Cushman, U. S. Nat. Mus. Bull. 71, pt. 6, p. 25, pl. 1, fig. 2; pl. 2, fig. 2, 1917; U. S. Geol. Survey Prof. Paper 129, p. 101, pl. 25, fig. 1, 1922.

Specimens similar to the tropical form of this species occur at three stations, as follows:

6447. Glass Bayou, Vicksburg, Miss.

6451, 6452. Mint Spring Bayou, Vicksburg, Miss.

The adults among these specimens are unlike the typical form of the species in having the last coil somewhat broadened and flattened, giving somewhat the appearance of *C. carinata* (Costa). The species was recorded from the Byram marl, but the specimens there were very small, measuring only 0.4 millimeter. Some of those from the Mint Spring marl measure 2 millimeters in diameter. This larger form of the species is common in the shoal waters of the Tropics, especially in the Indo-Pacific.

Genus **SPIROLOCULINA** D'Orbigny, 1826.

Spiroloculina imprimata Cushman.

Spiroloculina imprimata Cushman, U. S. Geol. Survey Prof. Paper 129, p. 101, pl. 25, figs. 3a, 3b, 1922.

Test broad and flat, complanate, nearly circular in outline, composed of numerous chambers, those of the last-formed coil failing to extend to the base of the preceding chamber, leav-

ing a gap; periphery square, lateral faces nearly flat; the surface ornamented by a series of pits in a more or less linear arrangement. Length about 1 millimeter.

A single specimen, much like that from the Byram marl, already described, occurred at station 6451 (Mint Spring Bayou, Vicksburg, Miss.), but this species was not found elsewhere in the material from the Mint Spring marl.

Spiroloculina antillarum D'Orbigny.

Plate XXXIII, figure 1.

Spiroloculina antillarum D'Orbigny, in De la Sagra, Histoire physique, politique et naturelle de l'île de Cuba, Foraminifères, p. 166, pl. 9 figs. 3, 4, 1839.
H. B. Brady, *Challenger* Rept., Zoology, vol. 9, p. 155, pl. 10, fig. 21, 1884.

Cushman, U. S. Geol. Survey Bull. 676, p. 21, pl. 8, fig. 2, 1918.

Spiroloculina grata Terquem, Soc. géol. France Mém., 3d ser., vol. 1, p. 55, pl. 5, figs. 14a-15b, 1878 (and subsequent authors).

Test elongate, twice as long as broad; chambers subtriangular; peripheral margin broadly rounded, ornamented by numerous longitudinal costae; apertural end extended. The costae are distinct and continue from one end to the other of the chambers without any trace of branching or anastomosing. Length 1 millimeter or less.

As noted in a paper on the recent Foraminifera from the shallow water of Jamaica⁶ this species, described by D'Orbigny from specimens obtained in Cuba and other West Indian localities as *S. antillarum*, is very similar to Terquem's *S. grata*, if not identical, and has priority of date. Specimens from the Mint Spring marl are very close to this form now living in the West Indies; they were found at stations 6451 and 6452, Mint Spring Bayou, Vicksburg, Miss.

Genus **VERTEBRALINA** D'Orbigny, 1826.

Vertebralina sp.

A single specimen from station 6451 (Mint Spring Bayou, Vicksburg, Miss.) is evidently the young of a species of *Vertebralina*, but the specimen is worn and can not be specifically identified.

⁶ Cushman, J. A., U. S. Nat. Mus. Proc., vol. 59, p. 63, pl. 14, figs. 14, 15, 1921.

Genus *QUINQUELOCULINA* D'Orbigny, 1826.*Quinqueloculina bicostata* D'Orbigny.

- Quinqueloculina bicostata* D'Orbigny, in De la Sagra, Histoire physique, politique et naturelle de l'île de Cuba, Foraminifères, p. 195, pl. 12, figs. 8-10, 1839.
Cushman, U. S. Nat. Mus. Bull. 71, pt. 6, p. 47, pl. 13, fig. 1, 1917; U. S. Geol. Survey Prof. Paper 129, p. 102, pl. 26, figs. 2-4, 1922.
Miliolina bicostata Heron-Allen and Earland, Zool. Soc. London Trans., vol. 20, p. 572, pl. 42, figs. 42-45, 1915.

The Mint Spring marl specimens referred to this species are considerably longer than those shown in D'Orbigny's type figures and resemble more those specimens from the Byram marl which I have referred to this species. These specimens came from the following stations:

6448. Glass Bayou, Vicksburg, Miss.
6451. Mint Spring Bayou, Vicksburg, Miss.

Quinqueloculina cuvieriana D'Orbigny.

- Quinqueloculina cuvieriana* D'Orbigny, in De la Sagra, Histoire physique, politique et naturelle de l'île de Cuba, Foraminifères, p. 164, pl. 11, figs. 19-21, 1839.
Cushman, U. S. Nat. Mus. Bull. 71, pt. 6, p. 47, pl. 12, fig. 2, 1917; U. S. Geol. Survey Prof. Paper 129, p. 102, pl. 26, fig. 1, 1922.

Test slightly longer than wide; chambers sharply angled, those of the adult with a secondary carina at each side of the periphery of the chamber; remainder of the surface smooth; aperture somewhat elongated with a simple tooth. Length 1 millimeter or less.

This species, which was found in the Byram marl, also occurred sparsely in the Mint Spring marl at the following stations:

6447. Glass Bayou, Vicksburg, Miss.
6452. Mint Spring Bayou, Vicksburg, Miss.

Quinqueloculina cookei Cushman, n. sp.

Plate XXXIII, figures 2, 3.

Test much elongate, somewhat fusiform; chambers narrow, widest near the base, rounded, apertural end extended, forming a subcylindrical neck with a simple tooth and slight lip; periphery of the test broad, carinate at each angle, slightly concave between the carinae; sutures distinct; surface smooth, shiny, except the carinae, which are dull. Length 1.5 millimeters or less, diameter 0.35 millimeter.

32333°—22—11

Type specimen from station 6451, Mint Spring Bayou, Vicksburg, Miss.

This species in some ways resembles *Q. bicostata*, but it is very elongate and slender, and its general form is entirely different.

Quinqueloculina vicksburgensis Cushman, n. sp.

Plate XXXIV, figure 6.

- Quinqueloculina venusta* Karrer? var., Cushman, U. S. Geol. Survey Prof. Paper 129, p. 102, pl. 26, fig. 5, 1922.

Test much elongate, narrow; chambers distinct; basal end broadly rounded, projecting; apertural end also projecting, forming a cylindrical neck and rounded aperture; periphery of the test subacute; surface smooth, dull. Length nearly 2 millimeters, width 0.5 millimeter.

Type specimens from station 6447, Glass Bayou, Vicksburg, Miss.

This is probably the same as the form recorded from the Byram marl as *Q. venusta* Karrer? var. It is a long, narrow species of peculiar form, as shown in the figure.

Quinqueloculina glabrata Cushman, n. sp.

Plate XXXIV, figure 8.

Test elongate, elliptical in side view, basal end of the chambers somewhat rounded; aperture slightly extending beyond the preceding chamber, aperture ovate with a simple tooth, tending to become bifid toward the tip; periphery of the test with an outside carina, the sides slightly concave; sutures distinct; surface smooth but not shiny. Length 1.5 millimeters, breadth 0.75 millimeter.

Type specimen from station 6447, Glass Bayou, Vicksburg, Miss. Several specimens of this species were also found at stations 6451 and 6452, Mint Spring Bayou, Vicksburg, Miss.

This species is very constant in its characters at all these stations.

Quinqueloculina lustra Cushman, n. sp.

Plate XXXIII, figure 6.

Test broadly elliptical, somewhat compressed; chambers broadly curved, of uniform width, at the basal end slightly projecting, the apertural end only slightly extending beyond

the outline of the chamber; surface smooth, shiny; sutures not very distinct; aperture nearly circular with a short, simple tooth. Length 1.25 millimeter, breadth 1 millimeter.

Type specimen from station 6448, Glass Bayou, Vicksburg, Miss.

This species has a peculiar rounded form, a smooth, shiny surface, and the periphery slightly angled.

***Quinqueloculina tessellata* Cushman, n. sp.**

Plate XXXIII, figure 8; Plate XXXIV, figure 1.

Test elongate, fusiform, in transverse section much angled; periphery rather sharply angled, sides flat and very slightly convex, apertural end very little extended; sutures not very distinct; surface ornamented by longitudinal rows of rather large pits, five or six rows on each side of the largest chamber. Length 1.25 millimeters, breadth 0.5 millimeter.

Type specimen from station 6447, Glass Bayou, Vicksburg, Miss. This form also occurred at station 6451, Mint Spring Bayou, Vicksburg, Miss. It was rare at both stations.

This is a peculiarly ornamented species, reminding one somewhat of the pattern found in some of the Miliolidae of the Eocene of the Paris Basin.

***Quinqueloculina vulgaris* D'Orbigny.**

Plate XXXII, figures 9, 10.

Quinqueloculina vulgaris D'Orbigny, Annales sci. nat., vol. 7, p. 302, No. 33, 1826.

Cushman, U. S. Nat. Mus. Bull. 71, pt. 6, p. 46, pl. 11, fig. 3, 1917.

Miliolina vulgaris Heron-Allen and Earland, Zool. Soc. London Trans., vol. 20, p. 569, 1915.

Test short and stout, about as long as wide, in front view orbicular; chambers in transverse section roughly triangular, the periphery bluntly angled, sides straight or slightly convex; sutures distinct, wall smooth; apertural end not contracted or produced; aperture elongate, narrow, with a tooth bifid at the tip, in front view projecting slightly above the border of the aperture. Length about 0.75 millimeter.

Specimens were common in the Mint Spring marl at station 6448, Glass Bayou, Vicksburg, Miss., and less so at the following stations:

6447. Glass Bayou, Vicksburg, Miss.

6451, 6452. Mint Spring Bayou, Vicksburg, Miss.

***Quinqueloculina seminulum* (Linnaeus) D'Orbigny.**

Serpula seminulum Linnaeus, Systema naturae, 10th ed. p. 786, 1758; 13th ed. (Gmelin's), pp. 37, 39, 1788.

Quinqueloculina seminulum D'Orbigny, Annales sci. nat., vol. 7, p. 303, No. 44, 1826.

Cushman, U. S. Nat. Mus. Bull. 71, pt. 6, p. 44, pl. 11, fig. 2, 1917.

Miliolina seminulum Williamson, Recent Foraminifera of Great Britain, p. 85, pl. 7, figs. 183-185, 1858.

H. B. Brady, Challenger Rept., Zoology, vol. 9, p. 157, pl. 5, figs. 6a-c, 1884.

Test somewhat longer than broad, smooth, peripheral margins rounded; sutures distinct; apertural end not exerted; aperture fairly large, oval, with a simple tooth becoming bifid at the free end. Length 1.5 millimeters or less.

Specimens that may be referred to this common species were collected at three stations in the Mint Spring marl, as follows:

6447. Glass Bayou, Vicksburg, Miss.

6451, 6452. Mint Spring Bayou, Vicksburg, Miss.

***Quinqueloculina contorta* D'Orbigny.**

Plate XXXIV, figures 2, 3.

Quinqueloculina contorta D'Orbigny, Foraminifères fossiles du bassin tertiaire de Vienne, p. 298, pl. 20, figs. 406, 1846.

Test elongate, oval; chambers narrow, of uniform width; periphery flattened, especially in the middle; sides flat or slightly concave, very slightly if at all extended at the apertural end; aperture rounded with a simple tooth; sutures distinct; surface smooth, flattened, periphery dull, sides somewhat glossy. Length 1 millimeter or less.

Specimens that can be referred to this species were fairly common at four stations in the Mint Spring marl, as follows:

6447, 6448. Glass Bayou, Vicksburg, Miss.

6451, 6452. Mint Spring Bayou, Vicksburg, Miss.

This species was described by D'Orbigny in his report on the Foraminifera from the Tertiary Vienna Basin. Our specimens are very similar to those figured by him.

***Quinqueloculina lamarckiana* D'Orbigny.**

Quinqueloculina lamarckiana D'Orbigny, in De la Sagra, Histoire physique, politique et naturelle de l'île de Cuba, Foraminifères, p. 187, pl. 11, figs. 14, 15, 1839.

Test short and broad; chambers with a sharp peripheral angle, sides slightly convex; aperture not produced; sutures distinct; surface smooth and shiny. Length 1 millimeter.

The only specimens from the Mint Spring marl that can be referred to this species were found at station 6447, Glass Bayou, Vicksburg, Miss.

Genus **ARTICULINA** D'Orbigny, 1826.

Articulina byramensis Cushman.

Articulina byramensis Cushman, U. S. Geol. Survey Prof. Paper 129, p. 103, pl. 27, figs. 5, 6, 1922.

Test of two portions, a basal triloculine portion followed by a single linear chamber, the earlier portion with the lip of the antepenultimate chamber standing out free at the base, that of the penultimate chamber covered by the base of the last-formed one, the last chamber rounded in transverse section or slightly compressed, with a broadly flaring, slightly downward curved lip; aperture rounded, slightly longer than wide; surface of the test with numerous longitudinal costae, sharp, sometimes, especially in the final chamber, anastomosing. Length 1.25 millimeters.

This species, which I have described and figured from specimens obtained in the Byram marl, also occurred in the Mint Spring marl at stations 6451 and 6452, Mint Spring Bayou, Vicksburg, Miss. The specimens are very similar to those from Byram, Miss., and show the specific characters.

Genus **MASSILINA** Schlumberger, 1893.

Massilina decorata Cushman, n. sp.

Plate XXXIV, figure 7.

Test much flattened, elliptical or oval, slightly longer than wide, basal and apertural ends projecting, the apertural end narrowed to a small cylindrical neck, nearly in the longitudinal axis of the test; sutures rather indistinct; surface dull white; periphery rounded, the sides ornamented by very fine pits, giving a finely granular appearance to the test. Length 1 millimeter or less.

Type specimens from station 6647, Chickasawhay River $1\frac{1}{4}$ miles southwest of Boice, Wayne County, Miss. This species also occurred at the following stations:

6452. Mint Spring Bayou, Vicksburg, Miss.

7671. "Brown's Cave," Leaf River, Miss.

This species in some ways resembles some of the specimens referred by Brady to *Spiroloculina tenuis* (Czjzek).

Genus **TRILOCULINA** D'Orbigny, 1826.

Triloculina peroblunga Cushman, n. sp.

Plate XXXIV, figures 4, 5.

Test much elongate, periphery rounded; chambers rounded at the base; the apertural end coming to or extending slightly beyond the base of the previous chamber; aperture rounded with a simple tooth and a slightly thickened lip; sutures distinct; wall dull white, smooth. Length 1.5 millimeters or less.

Type specimen from station 6451, Mint Spring Bayou, Vicksburg, Miss.

One of the specimens figured shows the aperture at each end, the last-formed chamber evidently having failed to cover the aperture of the preceding chamber, an unusual occurrence in this group.

Triloculina sculpturata Cushman, n. sp.

Plate XXXIII, figures 4, 5.

Test about twice as long as wide; periphery rounded or truncate; sutures indistinct; surface peculiarly sculptured, in general formed of longitudinal costae with broad surfaces, together with irregular connections, forming areolae; aperture rounded, with a simple tooth. Length 0.5 millimeter.

Type specimen from station 6451, Mint Spring Bayou, Vicksburg, Miss. This species was also found at station 6447, Glass Bayou, Vicksburg, Miss.

In its quinqueloculine stage this species has a somewhat extended neck, but in its adult character the aperture does not usually extend beyond the base of the previously formed chamber.

Genus **BILOCULINA** D'Orbigny, 1826.

Biloculina ornata D'Orbigny.

Plate XXXIII, figure 7.

Biloculina ornata D'Orbigny, Foraminifères fossiles du bassin tertiaire de Vienne, p. 266, pl. 16, figs. 7-9, 1846.

Test slightly longer than wide, each chamber broadest toward the basal end; aperture broadly rounded, the tooth somewhat bifid; surface smooth, dull. Length 0.40 millimeter.

Specimens that may be referred to this species occurred in the Mint Spring marl at stations 6451 and 6452, Mint Spring Bayou, Vicksburg, Miss.

PLATES XXIX-XXXV.

PLATE XXIX.

- FIGURE 1. *Bolivina cooki* Cushman, n. sp. Front view of type specimen, $\times 120$. Station 6647, Chickasawhay River 1 $\frac{1}{4}$ miles southwest of Boice, Miss.
2. *Bolivina vicksburgensis* Cushman, n. sp. Side view of type specimen, $\times 120$. Station 6451, Mint Spring Bayou, Vicksburg, Miss.
3. *Bolivina fronda* Cushman, n. sp. Side view of type specimen, $\times 120$. Station 6647, Chickasawhay River 1 $\frac{1}{4}$ miles southwest of Boice, Miss.
4. *Verniculina retimargo* Cushman, n. sp. View of flat face, $\times 100$. Station 6451, Mint Spring Bayou, Vicksburg, Miss.
5. *Verniculina retimargo* Cushman, n. sp. View of two faces, $\times 100$. Station 6447, Glass Bayou, Vicksburg, Miss.
6. *Gaudryina* sp. Front view, $\times 120$. Station 6451, Mint Spring Bayou, Vicksburg, Miss.
7. *Bulinina papoides* D'Orbigny. Side view, $\times 100$. Station 6647, Chickasawhay River 1 $\frac{1}{4}$ miles southwest of Boice, Miss.
8. *Buliminella subteres* H. B. Brady var. *angusta* Cushman, n. var. Front view, $\times 120$. Type specimen, station 6647, Chickasawhay River 1 $\frac{1}{4}$ miles southwest of Boice, Miss.
9. *Buliminella subteres* H. B. Brady var. *angusta* Cushman, n. var. $\times 120$. Station 6447, Glass Bayou, Vicksburg, Miss.
10. *Lagena striata* (D'Orbigny) Reuss var. *substriata* Williamson. $\times 100$. Station 7671, "Brown's Cave," Leaf River, Miss.
11. *Lagena orbiquana* (Seguenza) H. B. Brady var. *flintii* Cushman, n. var. Front view of type specimen, $\times 100$. Station 6447, Glass Bayou, Vicksburg, Miss.
12. *Lagena brucagona* (Williamson) Siddall. Front view, $\times 100$. Station 6452, Mint Spring Bayou, Vicksburg, Miss.

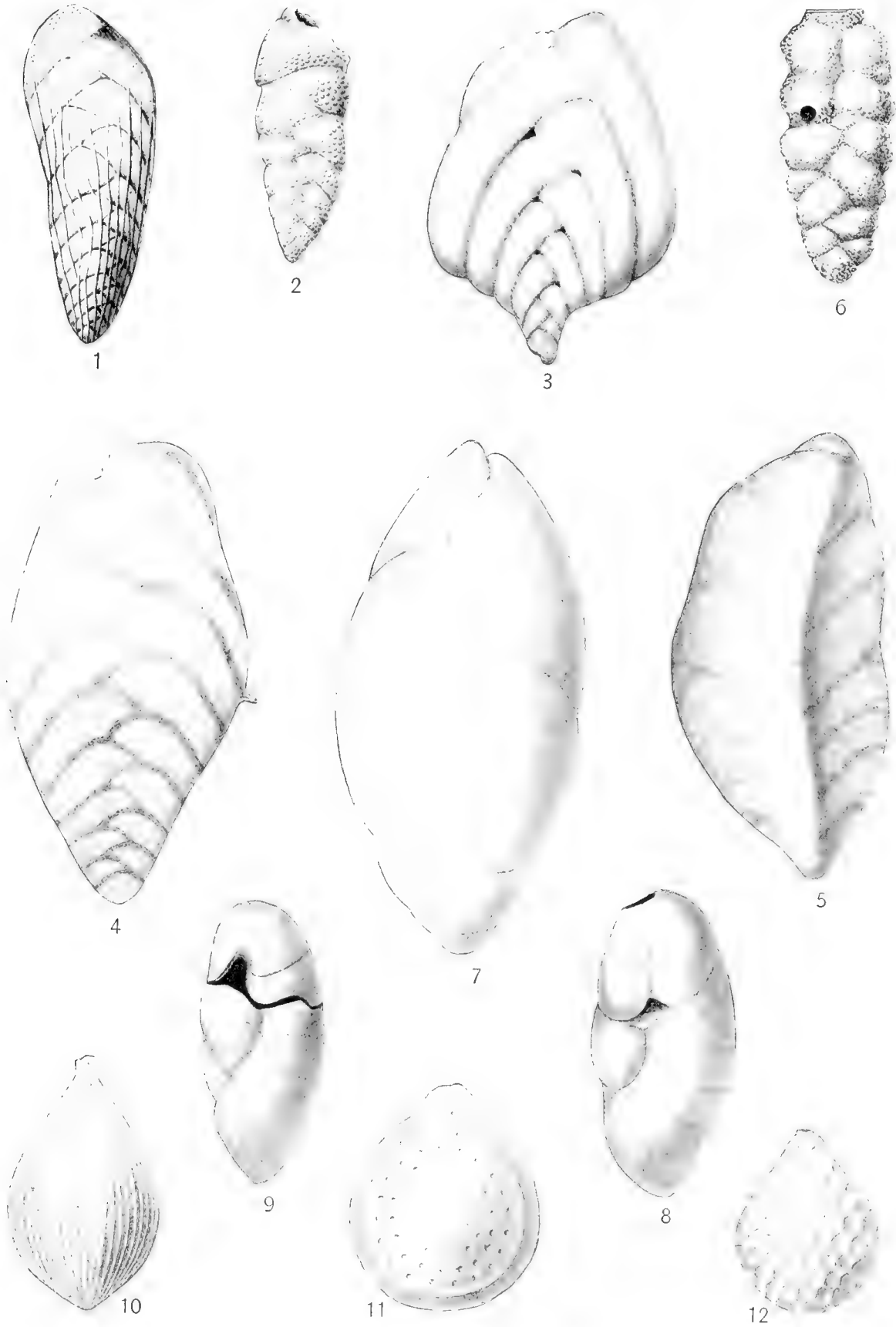

FORAMINIFERA OF THE MINT SPRING CALCAREOUS MARL.

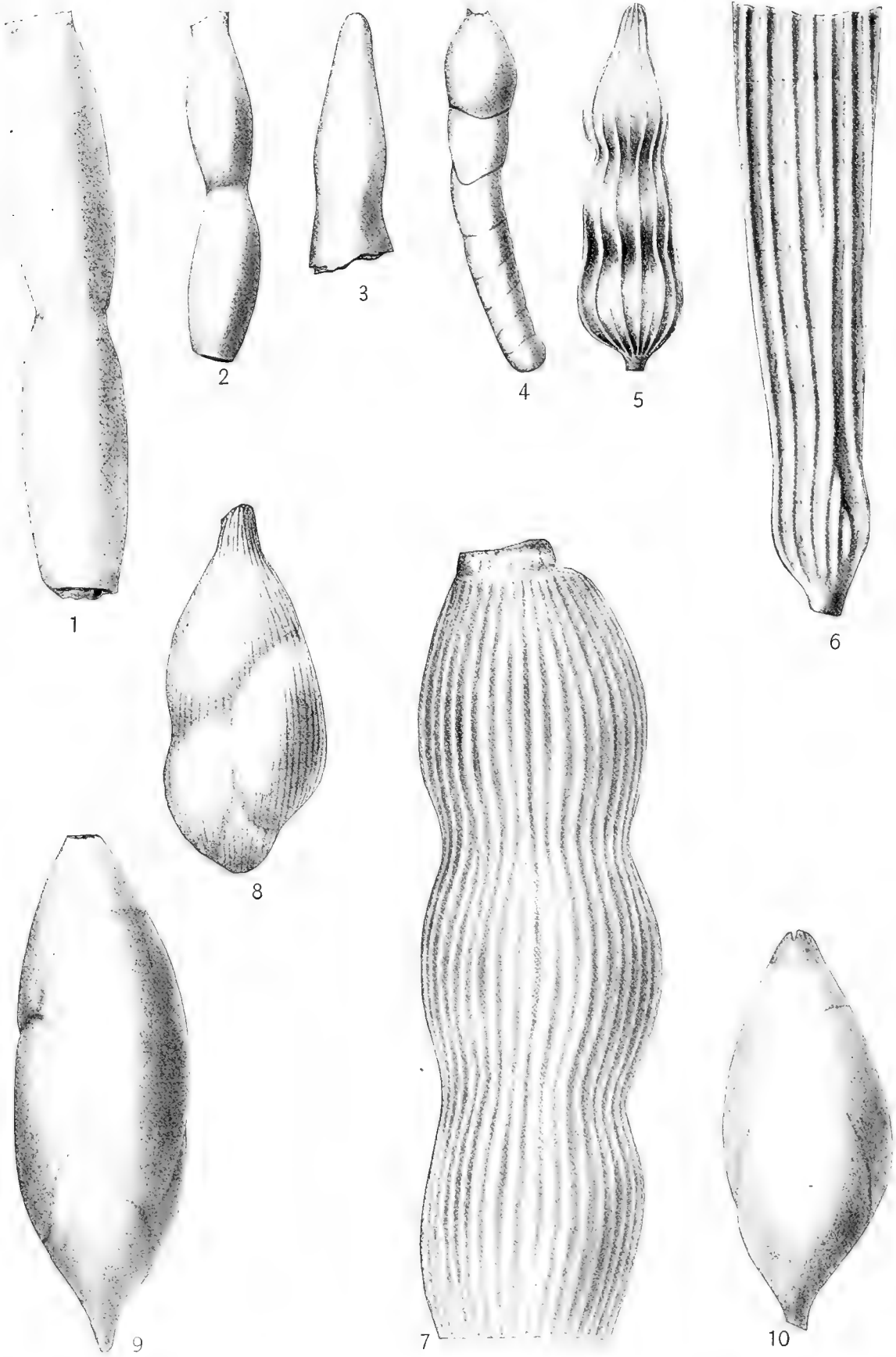

FORAMINIFERA OF THE MINT SPRING CALCAREOUS MARL.

PLATE XXX.

- FIGURE 1. *Nodosaria filiformis* D'Orbigny. Side view of two chambers, $\times 100$. Station 6447, Glass Bayou, Vicksburg, Miss.
2. *Nodosaria filiformis* D'Orbigny. Side view of two chambers near the aperture, $\times 100$. Station 7671, "Brown's Cave," Leaf River, Miss.
3. *Nodosaria filiformis* D'Orbigny. View of broken apertural end, $\times 100$. Station 7671, "Brown's Cave," Leaf River, Miss.
4. *Nodosaria communis* D'Orbigny. $\times 100$. Station 7671, "Brown's Cave," Leaf River, Miss.
5. *Nodosaria* sp. Side view, $\times 100$. Station 7671, "Brown's Cave," Leaf River, Miss.
6. *Nodosaria obliqua* (Linnaeus) H. B. Brady. View of early portion of specimen, $\times 75$. Station 7671, "Brown's Cave," Leaf River, Miss.
7. *Nodosaria obliqua* (Linnaeus) H. B. Brady. View of terminal portion of larger specimen, $\times 75$. Station 7671, "Brown's Cave," Leaf River, Miss.
8. *Polymorphina regina* H. B. Brady, Parker, and Jones. Side view, $\times 125$. Station 7671, "Brown's Cave," Leaf River, Miss.
9. *Polymorphina cuspidata* H. B. Brady. Side view, $\times 125$. Station 6447, Glass Bayou, Vicksburg, Miss.
10. *Polymorphina cuspidata* H. B. Brady. Side view, $\times 125$. Station 6447, Glass Bayou, Vicksburg, Miss.

PLATE XXXI.

- FIGURE 1. *Polymorphina cuspidata* H. B. Brady var. *costalata* Cushman, n. var. Front view of type specimen, $\times 125$. Station 6452, Mint Spring Bayou, Vicksburg, Miss.
2. *Polymorphina vicksburgensis* Cushman, n. sp. Front view of type specimen, $\times 125$. Station 6451, Mint Spring Bayou, Vicksburg, Miss.
3. *Polymorphina aequalis* D'Orbigny. Front view, $\times 125$. Station 6448, Glass Bayou, Vicksburg, Miss.
4. *Polymorphina advena* Cushman, n. sp. Front view of type specimen, $\times 125$. Station 6451, Mint Spring Bayou, Vicksburg, Miss.
5. *Polymorphina spinosa* D'Orbigny, $\times 125$. Station 7671, "Brown's Cave," Leaf River, Miss.
6. *Cristellaria vicksburgensis* Cushman, n. sp. Side view of type specimen, $\times 100$. Station 6647, Chickasawhay River $1\frac{1}{4}$ miles southwest of Poice, Miss.
7. *Cristellaria vicksburgensis* Cushman, n. sp. Side view of more complete specimen, $\times 100$. Station 7671, "Brown's Cave," Leaf River, Miss.
8. *Cristellaria cultrata* (Montfort) Parker and Jones. Side view, $\times 50$. Station 7671, "Brown's Cave," Leaf River, Miss.
9. *Patellina advena* Cushman, n. sp. Dorsal view of type specimen, $\times 125$. Station 6452, Mint Spring Bayou, Vicksburg, Miss.

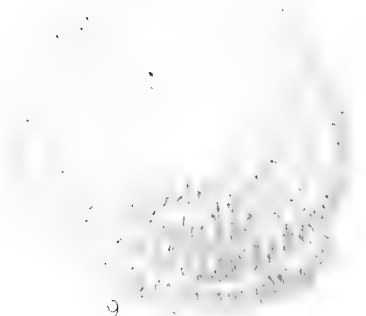
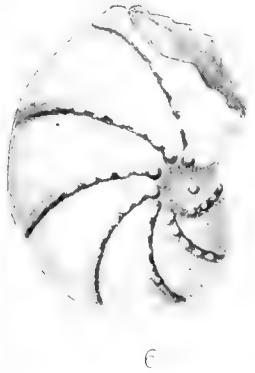
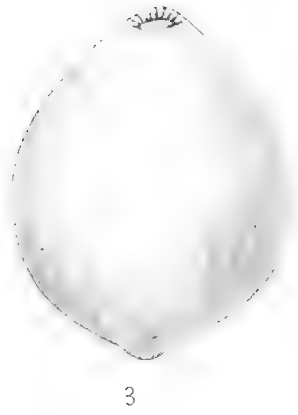
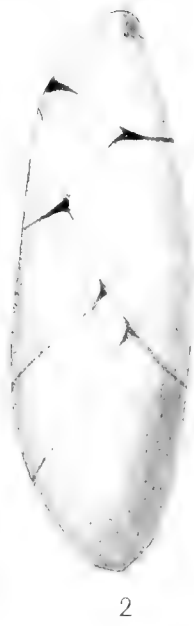

FORAMINIFERA OF THE MINT SPRING CALCAREOUS MARL.

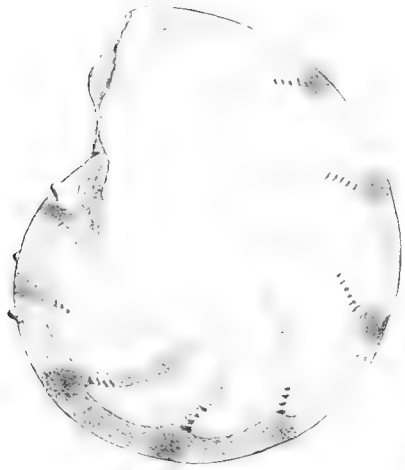

1

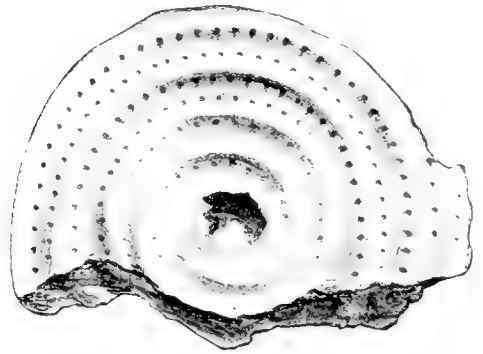

3

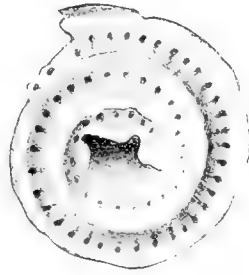

4



5



2

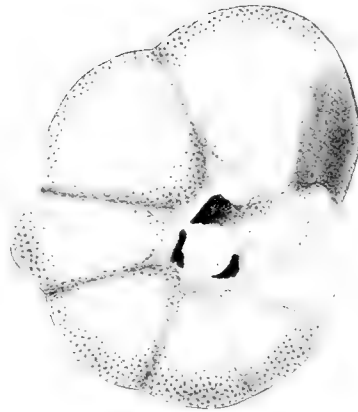

6



7



8



9



10

FORAMINIFERA OF THE MINT SPRING CALCAREOUS MARL.

PLATE XXXII.

- FIGURE 1. *Cristellaria rotulata* (Lamarck) D'Orbigny. Side view, $\times 50$. Station 7671, "Brown's Cave," Leaf River, Miss.
2. *Uvigerina pigmea* D'Orbigny. Side view, $\times 125$. Station 6647, Chickasawhay River $1\frac{1}{4}$ miles southwest of Boice, Miss.
3. *Spirillina limbata* H. B. Brady var. *bipunctata* Cushman, n. var. Dorsal view of type specimen, $\times 125$. Station 7671, "Brown's Cave," Leaf River, Miss. Specimen showing the adult character of the double row of punctations.
4. *Spirillina limbata* H. B. Brady var. *bipunctata* Cushman, n. var. Dorsal view of young specimen, showing but a single row of punctations, $\times 125$. Station 6447, Glass Bayou, Vicksburg, Miss.
5. *Spirillina limbata* H. B. Brady var. *bipunctata* Cushman, n. var. Ventral view, $\times 125$. Station 6647, Chickasawhay River $1\frac{1}{4}$ miles southwest of Boice, Miss.
6. *Discorbis auracana* (D'Orbigny) Cushman. Ventral view, $\times 125$. Station 6447, Glass Bayou, Vicksburg, Miss.
7. *Discorbis bertheloti* (D'Orbigny) Cushman. Dorsal view, $\times 125$. Station 6451, Mint Spring Bayou, Vicksburg, Miss.
8. *Nonionina adrena* Cushman, n. sp. Side view of type specimen, $\times 125$. Station 6647, Chickasawhay River $1\frac{1}{4}$ miles southwest of Boice, Miss.
9. *Quinqueloculina vulgaris* D'Orbigny. Side view, $\times 125$. Station 6448, Glass Bayou, Vicksburg, Miss.
10. *Quinqueloculina vulgaris* D'Orbigny. Side view of another specimen from the opposite side. Station 6448, Glass Bayou, Vicksburg, Miss.

PLATE XXXIII.

- FIGURE 1. *Spicoloculina antillarum* D'Orbigny. Side view, $\times 125$. Station 6451, Mint Spring Bayou, Vicksburg, Miss.
2. *Quinqueloculina cooki* Cushman, n. sp. Side view of type specimen, $\times 125$. Station 6451, Mint Spring Bayou, Vicksburg, Miss.
3. *Quinqueloculina cooki* Cushman, n. sp. Side view of another specimen from opposite side, $\times 125$. Station 6451, Mint Spring Bayou, Vicksburg, Miss.
4. *Triloculina sculpturata* Cushman, n. sp. Side view of type specimen, $\times 125$. Station 6451, Mint Spring Bayou, Vicksburg, Miss.
5. *Triloculina sculpturata* Cushman, n. sp. Viewed from the side of the last-formed chamber, $\times 125$. Station 6451, Mint Spring Bayou, Vicksburg, Miss.
6. *Quinqueloculina lutea* Cushman, n. sp. Side view of type specimen, $\times 125$. Station 6448, Glass Bayou, Vicksburg, Miss.
7. *Biloculina inornata* D'Orbigny. Front view, $\times 100$. Station 6452, Mint Spring Bayou, Vicksburg, Miss.
8. *Quinqueloculina tessellata* Cushman, n. sp. Side view of type specimen, $\times 125$. Station 6447, Glass Bayou, Vicksburg, Miss.



1



2



3



5



4



7



6

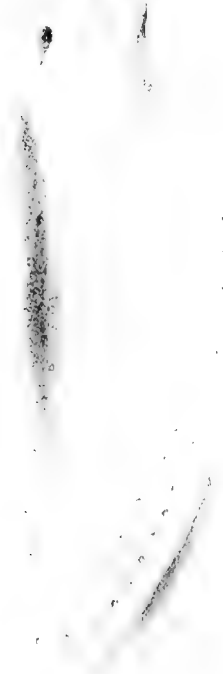

8



FORAMINIFERA OF THE MINT SPRING CALCAREOUS MARL.

PLATE XXXIV.

- FIGURE 1. *Quinqueloculina tessellata* Cushman, n. sp. Side view, $\times 125$. Station 6451, Mint Spring Bayou, Vicksburg, Miss.
2. *Quinqueloculina contorta* D'Orbigny. Side view, $\times 125$. Station 6448, Glass Bayou, Vicksburg, Miss.
3. *Quinqueloculina contorta* D'Orbigny. Side view, $\times 125$. Station 6448, Glass Bayou, Vicksburg, Miss.
4. *Triloculina peroblunga* Cushman, n. sp. Specimen with double aperture, one at each end, through failure of the last-formed chamber to cover the preceding chamber completely, $\times 125$. Station 6451, Mint Spring Bayou, Vicksburg, Miss.
5. *Triloculina peroblunga* Cushman, n. sp. Type specimen, $\times 125$. Station 6451, Mint Spring Bayou, Vicksburg, Miss.
6. *Quinqueloculina ricksburgensis* Cushman, n. sp. Side view of type specimen, $\times 125$. Station 6447, Glass Bayou, Vicksburg, Miss.
7. *Massilina decorata* Cushman, n. sp. Side view of type specimen, $\times 125$. Station 6647, Chickasawhay River $1\frac{1}{4}$ miles southwest of Boice, Miss.
8. *Quinqueloculina glabrata* Cushman, n. sp. Side view of type specimen, $\times 125$. Station 6447, Glass Bayou, Vicksburg, Miss.

PLATE XXXV.

- FIGURE 1. *Rotalia dentata* Parker and Jones var. *parva* Cushman, n. var. Ventral view, $\times 100$. Station 6451, Mint Spring Bayou, Vicksburg, Miss.
2. *Rotalia dentata* Parker and Jones var. *parva* Cushman, n. var. Dorsal view, $\times 100$. Station 6448, Glass Bayou, Vicksburg, Miss.
3. *Rotalia vicksburgensis* Cushman, n. sp. Ventral view, $\times 100$. Station 6647, Chickasawhay River $1\frac{1}{4}$ miles southwest of Boice, Miss.
4. *Rotalia vicksburgensis* Cushman, n. sp. Dorsal view, $\times 100$. Station 6647, Chickasawhay River $1\frac{1}{4}$ miles southwest of Boice, Miss.
5. *Anomalina vicksburgensis* Cushman, n. sp. Dorsal view, $\times 100$. Station 6452, Mint Spring Bayou, Vicksburg, Miss.
6. *Anomalina vicksburgensis* Cushman, n. sp. Ventral view, $\times 100$. Station 6452, Mint Spring Bayou, Vicksburg, Miss.
7. *Truncatolina vicksburgensis* Cushman, n. sp. Dorsal view, $\times 100$. Station 6448, Glass Bayou, Vicksburg, Miss.
8. *Truncatolina vicksburgensis* Cushman, n. sp. Ventral view, $\times 100$. Station 6448, Glass Bayou, Vicksburg, Miss.

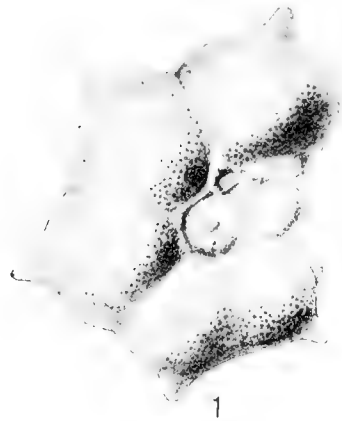

1



2



5

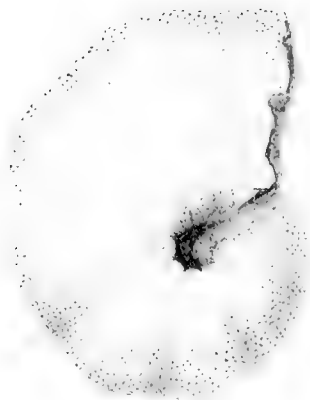

3

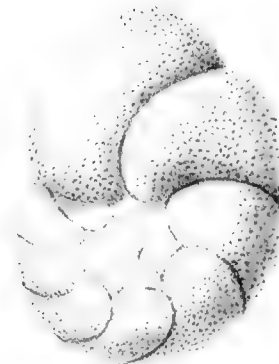

4



6

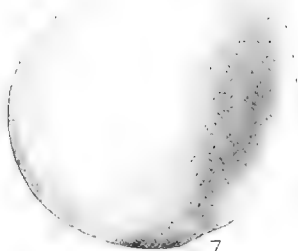

7



8

FORAMINIFERA OF THE MINT SPRING CALCAREOUS MARL.

THE FLORA OF THE WOODBINE SAND AT ARTHURS BLUFF, TEXAS.

By EDWARD WILBER BERRY.

INTRODUCTION.

The presence of fossil plants in the Cretaceous strata of Lamar County, Tex., has been known for over half a century, as is shown by a letter from Dr. B. F. Shumard dated October 2, 1860, read before the Academy of Science of St. Louis at its session of November 5, 1860.¹ Dr. Shumard, at that time State geologist of Texas, states that his brother, Dr. G. G. Shumard, discovered in the Cretaceous yellowish sandstones of Lamar County near Red River numerous dicotyledonous leaves resembling the modern leaves of *Salix*, *Ilex*, *Laurus*, etc. These fossils were undoubtedly from the locality now known as Arthurs Bluff (fig. 11, p. 180), which has furnished most of the subsequent collections. Dr. Shumard further states that these plants were sent to Leo Lesquereux for determination, but if sent they were apparently lost in transit.²

When R. T. Hill took up the study of the Texas Cretaceous, new collections were made between 1880 and 1885 at Arthurs Bluff and at Denison, the latter a locality originally discovered by Dr. Shumard. These collections were, according to Hill, sent to the United States National Museum and lost in storage. Finally, in Hill's great work on the Texas Cretaceous,³ F. H. Knowlton furnished a report on collections of fossil plants from the Woodbine sand at Arthurs Bluff, Lamar County; Woodbine, Cooke County; and Denison, Grayson County. The largest of these collections is the one from Arthurs Bluff, which was made in 1894 by T. Wayland Vaughan. The plants are preserved in a fragmentary state in a yellowish ferruginous sandy clay or loose sandstone. Knowlton identified the following species from this locality:

Aralia wellingtoniana vaughanii Knowlton.
Benzoin venustum (Lesquereux) Knowlton.

¹ Acad. Sci. St. Louis Trans., vol. 2, p. 140, 1868.

² Lesquereux, Leo, Cretaceous flora: U. S. Geol. Survey Terr. Rept., vol. 6, p. 11, 1874.

³ Hill, R. T., Geography and geology of the Black and Grand prairies, Tex.: U. S. Geol. Survey Twenty-first Ann. Rept., pt. 7, pp. 314-318, pl. 39, 1901.

Diospyros primaeva Heer.
Ficus glascocana Lesquereux?
Liriodendron pinnatifidum Lesquereux?
Myrica longa (Heer) Heer.
Phyllites rhomboideus Lesquereux.
Platanus primaeva Lesquereux.
Sapindus morrisoni Heer?
Salix deleta Lesquereux.
Viburnum robustum Lesquereux.

The collection from Woodbine was made by G. H. Ragsdale and is reported as containing these species:

Andromeda pfalliana Heer.
Cinnamomum ellipsoideum Saporta and Marion.
Cinnamomum sp.?
Diospyros primaeva Heer.
Eugenia primaeva Lesquereux.
Phyllites aristolochiaeformis Lesquereux?

The collection from Denison was made by T. V. Munson from two outcrops on Munson Hill, from which Knowlton was unable to identify any forms specifically, and Rhamey Hill, from which the following are recorded:

Cinnamomum heerii Lesquereux.
Diospyros steenstrupi Heer.
Inga cretacea Lesquereux.
Laurus proteaeifolium Lesquereux.
Liquidambar integrifolium Lesquereux.
Magnolia boulayana Lesquereux.
Magnolia speciosa Heer.
Populus sp.?
Salix sp.?

In 1911 T. W. Stanton and L. W. Stephenson visited Arthurs Bluff and made a collection of fossil plants which were sent to me. I made a report on these plants the next year,⁴ the following species having been recognized:

Andromeda novae-caesareae Hollick.
Andromeda snowii Lesquereux.
Aralia wellingtoniana Lesquereux.
Benzoin venustum (Lesquereux) Knowlton?
Brachyphyllum macrocarpum formosum Berry.
Cinnamomum membranaceum (Lesquereux) Hollick.
Colutea primordialis Heer.
Cornophyllum vetustum Newberry.

⁴ Berry, E. W., Contributions to the Mesozoic flora of the Atlantic Coastal Plain—VIII, Texas: Torrey Bot. Club Bull., vol. 39, pp. 387-406, pls. 30-32, 1912.

Eucalyptus geinitzi (Heer) Heer.
 Ficus daphnogenoides (Heer) Berry.
 Laurophyllum minus Newberry.
 Laurus plutonia Heer.
 Liriodendron quercifolium Newberry.
 Magnolia speciosa Heer.
 Malapoenna falcifolia (Lesquereux) Knowlton?
 Myrica emarginata Heer.
 Oreodaphneala bamensis Berry.
 Palaeocassia laurinea Lesquereux.
 Podozamites lanceolatus (Lindley and Hutton)
 Braun
 Populus harkeriana Lesquereux.
 Rhamnus tenax Lesquereux.
 Rhus redditifolmis Berry.
 Sapindus morrisoni Heer.
 Sterculia lugubris Lesquereux?
 Tricalycites papyraceus Newberry.
 Viburnum robustum Lesquereux?
 Zizyphus lamarensis Berry.

It was deemed desirable, in connection with the problem of the age of the Dakota sandstone and the relation between the Upper Cretaceous formations of the Coastal Plain and those of the Western Interior, that the flora of the Woodbine sand should be critically reviewed.

Consequently all the material in the United States National Museum from Arthurs Bluff was sent to me and constitutes the basis of the present report. I have never visited the region, nor have I seen the collections from Cooke and Grayson counties, hence recorded forms from these localities are ignored unless they are present in the collections studied. The total number of species in the Arthurs Bluff material amounts to 43, and it is probable that detailed explorations would double or treble the number of known forms. Hence the present report must be regarded entirely as a preliminary contribution.

Fortunately the conclusions to be derived from a study of this small flora are so complete and decisive as regards the age and relationship of the deposits that no subsequent additions to the flora can change the general conclusions, and this fact must be the excuse for calling an account of but 43 species from a single locality the flora of the Woodbine formation.

THE WOODBINE SAND.

NAME.

The name Woodbine formation was proposed by Hill⁶ in 1901 from the town of Woodbine, in the northeastern part of Cooke County,

Tex. On account of the predominance of unconsolidated sand the formation is now called the Woodbine sand. These beds have a somewhat complicated nomenclatorial history. Hill some years earlier⁶ called them the "Timber Creek group" or "Lower Cross Timbers formation." In still earlier years they had usually been considered of Tertiary age. They were originally described by G. G. Shumard as the "arenaceous and marly clay or Red River group" and referred to the Tertiary. His brother, who was the first to record fossil plants from these strata, placed them in various positions in the sections of Texas formations which he published at different times.

Hill clearly recognized their equivalence with the Dakota sandstone but quite rightly objected to the indiscriminate use of that term and fortunately decided to apply the local name.

CHARACTER OF MATERIALS.

The Woodbine materials are largely current-bedded sands, generally white and friable where nonferruginous, in places brownish and consolidated by iron oxide, containing extensive to small lenses of more or less carbonaceous laminated clays with some interbedded layers of lignite or lignitic clay. They give rise to sandy soils strewn with fragments of ferruginous sandstone and siliceous ironstone.

The limits of the Woodbine are uncertain. It is said to be unconformable with the underlying Denison formation of the Washita group and to pass without a break into the overlying Eagle Ford formation. Taff⁷ described the formation under the name Dakota sand and divided it into Timber Creek beds, Dexter sand, and basal clay. Hill combined the lower two divisions under the name Dexter sands and renamed the upper division the Lewisville beds because Timber Creek was preoccupied. The fossil plants described in the present report are said to come from Hill's Dexter sand member, the overlying Lewisville member, which makes up from 50 to 100 feet of the several hundred feet of total thickness of the Woodbine, being marine and so far as known lacking determinable fossil plants.

The Woodbine sediments from a maximum thickness of 300 to 500 feet in the Red River

⁶ Am. Jour. Sci., 3d ser., vol. 33, pp. 291-303, 1887.

⁷ Taff, J. A., Texas Geol. Survey Fourth Ann. Rept., p. 285, 1892.

⁸ Hill, R. T., op. cit., p. 291.

valley thin toward the south or are replaced by different lithologic facies which have received other names and whose equivalence has not been determined. No representative of the Woodbine has been recognized in central Texas, where, according to Stephenson,⁸ its age equivalent is absent or "lies in the relatively thin sediments that compose the Buda limestone, a supposition which seems highly improbable and which has no basis of known facts." A third alternative which I regard as more probable than the two advanced by Stephenson is that the leaf-bearing sands of Red River which are referred to the lower Woodbine are the time equivalent of what is called Eagle Ford in the Austin section. Either Woodbine time is represented there by the Buda limestone, which Stephenson states is highly improbable, or it is represented by a break in sedimentation, which seems to me equally improbable, or it is represented by the lower part of the Eagle Ford of that section.

FAUNA.

The fauna of the Woodbine, which comes from the upper part, or the Lewisville marine member, is not extensive, but certain species are individually abundant at some localities. It comprises an almost unique assemblage of shallow-water forms as identified by Cragin, including the following:

- Arca galliennei* var. *tramatensis* Cragin.
- Ostrea soleniscus* Meek.
- Modiola filisculpta* Cragin.
- Aguileria cummingsi* White.
- Cytherea leveretti* Cragin.
- Trigonarca siouxensis* (Hall and Meek).
- Turritella renauxiana* D'Orbigny.
- Cerithium tramatensis* Cragin.
- Cerithium interlineatum* Cragin.
- Pteria salinensis* White?
- Natica humilis* Cragin.

It contains also a considerable number of additional forms including ammonites, not yet determined. It is unfortunate that no adequate study of the Woodbine fauna has ever been made.

FLORA.

The flora of the Woodbine sand described in the following pages amounts to only 43 species. It is hence inadequate for a correct estimate

of its botanic facies, and the absence of forms normally present in beds of equivalent age may, with much probability, be attributed to their lack of discovery in the Woodbine, for as far as it goes it is a perfectly normal assemblage of forms such as would be expected at this horizon. There are no known ferns or lower plants present, presumably because of the coarseness of the sediments and the trituration to which most of the plants have evidently been subjected.

Only two gymnosperms are represented, a *Podozamites* and a *Brachyphyllum*. In this respect the Woodbine flora is more like the Dakota flora than it is like the corresponding floras of the Atlantic Coastal Plain, in which conifers are usually abundant individually and varied specifically. No monocotyledonous angiosperms have been recognized in the Woodbine, and this lack, like that of the ferns, is probably to be attributed to macerating and triturating water action.

The dicotyledons, which comprise 41 of the 43 identified forms, represent 31 genera in 21 families and 15 orders. They are well scattered among the families usually represented in Upper Cretaceous floras. Elements that are conspicuous by their absence when the Woodbine flora is compared with the Tuscaloosa flora of the eastern Gulf area, for example, are the numerous species of figs and magnolias, for there are only two of each of these types in the Woodbine, and one of the figs is a Dakota sandstone species and not a Coastal Plain species. Other notable absentees are *Menispermites*, *Bauhinia*, *Liriodendropsis*, *Leguminosites*, *Celastrophyllum*, *Grewiopsis*, *Pterospermites*, *Sapotacites*, and other less significant genera. The genus *Celastrophyllum* is especially abundant in the Tuscaloosa, in which 12 species have been recognized, and it is almost equally abundant in the Raritan formation.

No genus is represented in the Woodbine by more than two species except the form genus *Carpolithus*. The largest family is the Lauraceae, with eight species; no other family has more than three species, and only two families, the Salicaceae and Magnoliaceae, reach that number. Similarly the largest order is the Thymeleales, with eight species, and the only order that approaches it in size is the Ranales, with five species.

⁸ Stephenson, L. W., U. S. Geol. Survey Prof. Paper 120, p. 145, 1918.

The flora, as at present known, is inadequate to indicate the environment in which the plants lived, but it clearly contains no unusual features, and I can see no reasons for supposing that the physical conditions were different from those which have been predicated from the much larger floras of the Tuscaloosa, Raritan, and Magothy formations, which have been discussed at length in various publications. A systematic list of the Woodbine flora at Arthurs Bluff follows:

- Gymnospermae:
Podozamites lanceolatus (Lindley and Hutton) F. Braun.
Brachyphyllum macrocarpum formosum Berry.
- Dicotyledonae:
 Myricales:
 Myricaceae:
Myrica emarginata Heer.
Myrica longa (Heer) Heer.
- Salicales:
 Salicaceae:
Salix lesquereuxii Berry.
Salix deleta Lesquereux?
Populus harkeriana Lesquereux.
- Urticales:
 Moraceae:
Ficus daphnogenoides (Heer) Berry.
Ficus glascoeana Lesquereux.
- Platanales:
 Platanaceae:
Platanus latior (Lesquereux) Knowlton.
- Ranales:
 Magnoliaceae:
Magnolia speciosa Heer.
Magnolia lacoeana Lesquereux.
Liriodendron quercifolium Newberry.
- Trochodendraceae:
Trochodendroides thomboideus (Lesquereux) Berry.
- Ranunculaceae?
Dewalquea insigniformis Berry.
- Rosales:
 Caesalpiniaceae:
Palaeocassia laurinea Lesquereux.
- Papilionaceae:
Colutea primordialis Heer.
- Sapindales:
 Sapindaceae:
Sapindus morrisoni Heer.
- Anacardiaceae:
Rhus reddiformis Berry.
- Rhamnales:
 Rhamnaceae:
Rhamnus tenax Lesquereux.
Zizyphus lamarensis Berry.
- Vitaceae:
Cissites formosus Heer.

Dicotyledonae—Continued.

- Malvales:
 Sterculiaceae:
Sterculia lugubris Lesquereux.
- Thymeleales:
 Lauraceae:
Benzoin venustum (Lesquereux) Knowlton.
Malapoenna falcifolia (Lesquereux) Knowlton.
Oreodaphne alabamensis Berry.
Cinnamomum newberryi Berry.
Cinnamomum membranaceum (Lesquereux) Hollick.
Laurus plintonia Heer.
Laurus antecessens Lesquereux.
Laurophyllum minus Newberry.
- Myrtales:
 Myrtaceae:
Myrtonium geinitzi (Heer).
- Umbellales:
 Araliaceae:
Aralia wellingtoniana Lesquereux.
Aralia saportana Lesquereux.
- Cornaceae:
Cornophyllum vetustum Newberry.
- Ericales?:
Andromeda novaecaeasareae Hollick.
Andromeda snowii Lesquereux.
- Ebenales:
 Ebenaceae:
Diospyros primaeva Heer.
- Rubiales:
 Caprifoliaceae:
Viburnum robustum Lesquereux.
- Position uncertain:
Tricalycites papyraceus Newberry.
Carpolithus sp. 1.
Carpolithus sp. 2.
Carpolithus sp. 3.

AGE OF THE FLORA.

RELATION TO THE FLORAS OF OTHER UPPER CRETACEOUS FORMATIONS OF THE COASTAL PLAIN.

Relation to the Bingen sand flora.—The geographically nearest flora to that of the Woodbine sand is that found in the Bingen sand of Arkansas. The Bingen is generally recognized as being, in part, at least, the equivalent of the Woodbine and also as representing all the Upper Cretaceous of Arkansas below the *Ecogyra ponderosa* zone. The latter fact is of especial importance in the final determination of the age of the Woodbine, for if the Bingen in its easternmost exposures represents the whole of the interval represented in northern Texas by the Woodbine and Eagle Ford formations there is no apparent reason why a part of the

Woodbine may not also represent the Eagle Ford. Such a conclusion would be in accord with the evidence of the fossil plants.

The flora of the Bingen sand is known only from a small collection made by H. D. Miser in Pike and Howard counties, Ark.⁹ It comprises but 27 named forms, and these are not all from one level; hence comparisons between it and that of the Woodbine are limited. In spite of this the Woodbine contains nine species that are common to the Bingen sand, including the *Dewalquea*, which is common in the upper Bingen and is confined to these two formations.

The upper Bingen was considered by me as the equivalent of the upper part of the Tuscaloosa and the Eutaw formation of the eastern Gulf area, and the lower Bingen as the equivalent of the lower Tuscaloosa and the Raritan formation.

Unfortunately for ease of correlation and intelligible discussion all the Upper Cretaceous formations of the Coastal Plain have been based upon lithologic differences instead of upon their contained faunas and floras, and as they overlap and intergrade laterally the limits of the same formation are not chronologically equivalent from locality to locality, so that precision in correlation must await the discovery and study of much more extensive paleontologic materials than are available at the present time.

Although the Bingen has been separated by Miser into upper and lower members, the known flora was found near the top of the lower member and near the base of the upper member and hence could not be expected to be as decisive as if it represented both earlier and later Bingen time. The present Woodbine flora comes from a single horizon and locality, and what the other 300 to 500 feet of the Woodbine would show if the flora were known in its entirety can only be surmised. Hence, inasmuch as names must be used in any discussion, it must be borne in mind that when I speak of the Woodbine flora or Woodbine sand my data are derived entirely from the single horizon represented at Arthurs Bluff on Red River. I can therefore only state the well-known fact that the Woodbine and Bingen formations are at least partly contemporaneous. I am of the opinion, which is based on the range of the

Woodbine plants in other formations, that Arthurs Bluff is approximately on the boundary between the lower and upper members of the Bingen as recognized by Miser in Arkansas in the specific area where he collected the fossil plants.

Relation to Tuscaloosa flora.—The flora of the Tuscaloosa formation is extensive, comprising 151 described species, recently monographed.¹⁰ The Tuscaloosa occupies the same stratigraphic position with respect to the Eutaw formation of the eastern Gulf area that the Woodbine does with respect to the Eagle Ford formation of the western Gulf area, and both the Eutaw and the Eagle Ford contain comparable marine faunal elements. The Tuscaloosa formation has been shown to be progressively younger when traced northward from western central Alabama, and in the report just cited I have shown its delta character and probable chronologic equivalence with a part of the marine Eutaw formation.

I suspect that the Woodbine might also be interpreted as made up of continental, delta, and marginal deposits, with similar relations to the marine Eagle Ford, but I have no basis for this inference except the writings of others. This would afford an excellent subject for field study. The Woodbine and Tuscaloosa floras have 22 species in common, so that it seems clear that the Woodbine and Tuscaloosa formations are equivalent, at least in part. Whether the Tuscaloosa elements that are conspicuously absent in the Woodbine represent real or only apparent differences can not be determined. I incline to the opinion that these differences are only apparent.

Relation to floras of other formations of the Coastal Plain.—The relation or degree of resemblance between the Woodbine flora and that of geographically more remote formations of the Atlantic Coastal Plain is well shown in the accompanying table of distribution. The Woodbine contains 20 species common to the Raritan, 18 common to the Magothy of the New Jersey-Maryland region, and 25 common to the two combined, thus emphasizing a well-known floral similarity seen throughout the Coastal Plain. This may mean that the Woodbine is equivalent to the upper Raritan and the Magothy, or simply that it is equivalent to the

⁹ Berry, E. W., *Torrey Bot. Club Bull.*, vol. 44, pp. 167-190, pl. 7, 1917.

¹⁰ Berry, E. W., *U. S. Geol. Survey Prof. Paper* 112, 1919.

Magothy, as a great many upper Raritan species survived into Magothy time. There are nine species common to the Woodbine and Black Creek formations, but six of these are widespread and long-lived forms without especial significance. Five of the Woodbine species are common to the Eutaw flora, and one extends as high as the Ripley formation of the eastern Gulf area.

RELATION TO THE FLORA OF THE DAKOTA SANDSTONE.

The flora of the Dakota sandstone is very large, embracing over 400 described species. It is also very obviously not all of the same age, but outside of certain areas in Kansas and Nebraska no data are available for determining what part of Dakota flora came from beds that merit that term and what part came from beds since discovered or suspected to be different.

Of the 43 Woodbine plants 30 are species of the Dakota sandstone flora. The community of facies is thus very great, and it is significant that of these 30 common species all but 10 are forms which their range in other formations proves to represent what for want of a better term might be termed the true Dakota flora, and three of these 10 are only doubtfully determined from the Morrison formation in Colorado¹¹ and these three occur definitely in the Tuscaloosa, Raritan, and Magothy formations, so that really 23 of the Woodbine plants are true Dakota forms. I regard the Woodbine as synchronous with this undelimited Dakota sandstone, which I regard as bearing the same relation to the Benton as the Woodbine does to the Eagle Ford and the Tuscaloosa does to the Eutaw.

RELATION TO THE FLORA OF THE CHEYENNE SANDSTONE.

The relations between the Woodbine flora and that of the Mentor formation of central Kansas are unknown and will remain so until the Mentor flora is carefully collected and studied. The Cheyenne sandstone of southern Kansas contains a considerable flora, recently studied by me, but there is not a single species common to the Woodbine and Cheyenne. Although both floras consist largely of so-called Dakota forms, some of these in the Cheyenne

sandstone are forms that may have come originally from the unrecognized Cheyenne sandstone or the supposed equivalent Mentor formation, and not from the true Dakota sandstone. The majority lack an outside distribution.

The Woodbine plants, on the other hand, as shown by the comparisons in the preceding sections, are nearly all well-known species of formations of known age of the Coastal Plain. There can not be the slightest doubt that the Woodbine sand is younger than the Cheyenne sandstone and synchronous with the true Dakota sandstone of the Western Interior. The Woodbine is also certainly younger than those beds in the West formerly confused with the Dakota and now known as the Purgatoire formation.

RELATION OF THE WOODBINE FLORA TO FLORAS OF OTHER AREAS.

None of the Woodbine species have been identified in the formations of the Montana group. Eight of the Woodbine species are found in the Atane beds and six in the Patoot beds of western Greenland.

The similarities of the flora to European Upper Cretaceous floras are reasonably close, but these similarities naturally seldom extend to the identical species, and where they do the particular forms are wide-ranging and long-lived species of slight value in precise correlation, as might be expected. The Woodbine contains five species common to European beds referred to the Cenomanian and three additional that are tentatively recognized at this European horizon. Similarly two species are identical with forms that occur in the European Turonian. None of the species are known in the Emscherian of Europe, although *Devalquea insigniformis* of the Woodbine is, as its name indicates, very close to the European Senonian species *Devalquea insignis* Debey.

The intrinsic character of the Woodbine flora necessitates considering it as either Cenomanian or Turonian when judged according to European standards. From its relationship with other more extensive formations of the Coastal Plain such as the Tuscaloosa and Magothy, in which the evidence is clearer, I would be inclined to consider the Woodbine flora as of Turonian age.

¹¹ Knowlton, F. H., Am. Jour. Sci., 4th ser., vol. 49, pp. 189-194, 1920.

Outside distribution of Woodbine flora.

	Dakota sandstone.	Tuscaloosa formation.	Bingen sand.	Raritan formation.	Magothy formation.	Black Creek formation.	Eutaw formation.	Ripley formation.	Atane beds.	Patoot beds.	Morrison formation.	Cenomanian.	Turonian.
<i>Podozamites lanceolatus</i>	×			×	×							×	
<i>Brachyphyllum macrocarpum</i> formosum.....		×			×	×	×					?	
<i>Myrica emarginata</i>	×	×		×					×				
<i>Myrica longa</i>	×	×	×		×				×	×			×
<i>Salix lesquereuxii</i>	×	×	×	×	×	×	×				?	×	
<i>Salix deleta?</i>	×												
<i>Populus harkeriana</i>	×			×									
<i>Ficus daphnogenoides</i>	×	×	×	×	×	×					?		
<i>Ficus glascocoeana</i>	×												
<i>Platanus latior</i>	×	×											
<i>Magnolia speciosa</i>	×	×		×	×						?	×	
<i>Magnolia laeocoeana</i>	×	×		×	×								
<i>Liriodendron quercifolium</i>			×	×									
<i>Trichodendroides rhomboides</i>	×												
<i>Dewalquea insigniformis</i>			×										
<i>Palaeocassia laurinea</i>	×	×											
<i>Colutea primordialis</i>	×		×	?	×				×				
<i>Sapindus morrisoni</i>	×	×	×		×	×				×			
<i>Rhus reddiformis</i>													
<i>Rhamnus tenax</i>	×	×										?	
<i>Zizyphus lamarensis</i>		×											
<i>Cissites formosus</i>	×									×			
<i>Sterculia lugubris</i>	×												
<i>Benzoin venustum</i>	×												
<i>Malapoenna falciifolia</i>	×	×			×								
<i>Oreodaphne alabamensis</i>		×											
<i>Cinnamomum newberryi</i>	×	×	×	×	×	×	×	×	×	×		?	
<i>Cinnamomum membranaceum</i>	×				×								
<i>Laurus plutonia</i>	×	×		×	×	×	×		×	×		?	
<i>Laurus antecedens?</i>	×				×								
<i>Laurphyllum minus?</i>				×									
<i>Myrtonium geinitzi</i>	×	×			×							×	×
<i>Aralia wellingtoniana</i>	×			×									
<i>Aralia saportana?</i>	×												
<i>Cornophyllum vetustum</i>		×		×									
<i>Andromeda novae-caesareae</i>					×	×							
<i>Andromeda snowii</i>	×												
<i>Diospyros primaeva</i>	×	×		×	×	×	×		×	×			
<i>Viburnum robustum</i>	×												
<i>Tricalycites papyraceus</i>		×			×								

SYSTEMATIC ACCOUNT OF THE FLORA.

Phylum CYCADOPHYTA.

Genus PODOZAMITES F. Braun.

Podozamites lanceolatus (Lindley and Hutton) F. Braun.

Plate XXXVI, figure 2.

Podozamites lanceolatus (Lindley and Hutton) F. Braun, in Münster, Beiträge zur Petrefactenkunde, vol. 2, pt. 6, p. 53, 1843.

Dawson, Roy. Soc. Canada Trans., vol. 3, sec. 4, p. 6, pl. 1, fig. 3, 1886.

Lesquereux, U. S. Geol. Survey Mon. 17, p. 28, pl. 1, figs. 5, 6, 1892.

Newberry, U. S. Geol. Survey Mon. 26, p. 44, pl. 13, fig. 2 [not figs. 1, 3, 4], 1896.

Penhallow, Canada Geol. Survey Summary Rept. 1904, p. 9, [1905].

Fontaine, in Ward, U. S. Geol. Survey Mon. 48, p. 110, pl. 24, figs. 17-20, 1905; U. S. Geol. Survey Twentieth Ann. Rept., pt. 2, p. 360, pl. 63, fig. 4; pl. 66, fig. 4; pl. 67, figs. 3, 4, 1900.

Knowlton, Smithsonian Misc. Coll., vol. 50, p. 120, 1907; U. S. Geol. Survey Prof. Paper 85, p. 52, 1914.

Hollick, U. S. Geol. Survey Mon. 50, p. 35, pl. 2, fig. 1, 1907; New York Bot. Garden Bull., vol. 8, p. 155, pl. 162; pl. 163, figs. 2, 3, 1912.

Berry, Torrey Bot. Club Bull., vol. 39, p. 391, 1913; Maryland Geol. Survey, Lower Cretaceous, p. 341, pl. 53, figs. 5, 6, 1911; Torrey Bot. Club Bull., vol. 38, p. 410, 1911; Maryland Geol. Survey, Upper Cretaceous, p. 772, 1916.

Pinnis distantibus, alternis oppositisve, elongatis, basi sensim angustatis, inferioribus lanceolato-linearibus, superioribus elongato-ellipticis; nervis crebris.—Schimper, 1870.

This is a species of great geologic range, being recorded from the Jurassic to the Upper Cretaceous. The geographic range is equally extensive, embracing two continents, North America and Europe. It is quite probable that the species is composite, but no certain grounds for segregation are apparent.

Some students may doubt the wisdom of correlating both Lower and Upper Cretaceous forms with a species which is essentially a Jurassic type, but specific differentiation founded merely upon stratigraphy has gone astray so often that in cases like the present synthesis may well precede analysis, and it might be added that this was the view taken by Hollick¹² with reference to material from Glen Cove, Long Island, and by Velenovsky¹³ in studying the Cenomanian flora of Bohemia.

Forms indistinguishable from the type of this species occur in both the Patuxent and Patapsco formations of the Potomac group, as well as in the Kootenai, Dakota, Black Creek, Raritan, and Magothy formations.

Phylum CONIFEROPHYTA.

Genus BRACHYPHYLLUM Brongniart.

Brachyphyllum macrocarpum formosum Berry.

Plate XXXVI, figure 1.

Brachyphyllum macrocarpum Berry, Torrey Bot. Club Bull., vol. 38, p. 183, 1910 (not Newberry, 1896); vol. 38, p. 420, 1911.

Brachyphyllum macrocarpum formosum Berry, idem, vol. 39, p. 392, pl. 30, 1912; U. S. Geol. Survey Prof. Paper 81, p. 106, 1904; Prof. Paper 112, p. 59, pl. 5, fig. 9, 1919.

Slender elongated twigs, pinnately branched, covered with medium-sized crowded, appressed leaves, spirally arranged. Leaves bluntly pointed, smooth, thick.

In the consideration of the various specimens which have been referred to *Brachyphyllum macrocarpum*, a very considerable variation within certain fixed limits is at once obvious. This variation is usually one of size, the more slender specimens being at the same time smoother. This characteristic has been frequently noted by me and is commented upon in print by Knowlton,¹⁴ who in discussing the

younger forms from Wyoming suggests that the species on the verge of extinction became smaller in its proportions. In studying the material from the South Atlantic and Gulf States a constant difference in size was noticed. This may reflect a slight difference in climatic conditions, and all the forms may be interpreted as the variations of a single species—in fact, the specimen from the Raritan formation in New Jersey illustrated in Newberry's figure 7¹⁵ is approximately of the same size as the forms from the Montana group of the West and is associated with the normal stout, club-shaped type. That the variety has no particular stratigraphic significance is indicated by its abundance at a horizon as low as the basal part of the Tuscaloosa of Alabama and its presence in the Woodbine sand of Lamar County, Tex. In general the present variety occurs in later and more southern beds than the type, a difference which might be ascribed to the fact that only the slender terminal twigs are preserved. This explanation is regarded as improbable, however, for the same reasoning should hold good for the areas where only thicker twigs have been found.

The remains are usually much macerated and broken, and the immediate cause for the recognition of a new variety was the discovery of a relatively large specimen from the Magothy formation of Maryland, which showed such striking unlikeness to the type that separation was demanded and specific differentiation was even considered. In view, however, of the occurrence of both forms in association in Maryland and the well-known variation not only of the type but of coniferous foliage in general, it seemed wiser to consider the present form as a variety of the type, which as time progressed supplanted it to a large extent if not altogether.

The new specimen from Maryland showed the terminal part of two approximately parallel and curved twigs about 12 centimeters in length, united proximad. These in their largest portion are only 6 millimeters in diameter. At intervals of 3 to 5 millimeters subopposite lateral branches are given off in a pinnate manner. These are relatively much elongated, curved, and slender, averaging about 4 centimeters in length by 2 millimeters

¹² Hollick, Arthur, U. S. Geol. Survey Mon. 50, p. 35, 1906.

¹³ Velenovsky, Josef, Die Gymnospermen der böhmischen Kreideformation, p. 11, pl. 2, figs. 11-19, 24, 1885.

¹⁴ Knowlton, F. H., U. S. Geol. Survey Bull. 163, p. 29, pl. 4, figs. 5, 6, 1900.

¹⁵ Newberry, J. S., U. S. Geol. Survey Mon. 25, pl. 7, figs. 1-7, 1896.

in diameter, bluntly pointed, and not tapering to any appreciable extent. A few of these lateral branches fork pseudodichotomously, and some of them give off toward their distal ends tiny lateral branchlets less than 1 centimeter in length and about 1 millimeter in diameter.

The general proportions are thus decidedly different from those of the supposed parent type. The leaves are slightly smaller and smoother and relatively somewhat more elongated, at the same time lacking the apical papilla and the convergent striae. The form is much more graceful in appearance than the type and in its general aspect suggests the Lower Cretaceous genus *Arthrotaxopsis* of Fontaine.

While tiny species of *Brachyphyllum* like *Brachyphyllum microcladum* Saporta, of the Neo-Jurassic, have been described, the new variety is even more slender than *Brachyphyllum gracile* Brongniart, of the Jurassic. The most closely allied form known appears to be one from the Albian of Buarcos, in Portugal, described by Saporta¹⁶ as *Brachyphyllum obesiforme elongatum*. The present form also shows considerable resemblance to *Brachyphyllum crassicaule* Fontaine, of the Patapsco formation in Maryland and Virginia.

This variety is abundant throughout the Tuscaloosa formation and in the basal part of the Eutaw formation in Alabama and western Georgia and occurs also in the Woodbine sand of Texas but is known in Maryland only from a single locality. It is also confined to a single locality in North Carolina, where it is not at all uncommon but is not especially well preserved.

Phylum **ANGIOSPERMOPHYTA.**

Class **DICOTYLEDONAE.**

Order **MYRICALES.**

Family **MYRICACEAE.**

Genus **MYRICA** De Candolle.

***Myrica emarginata* Heer.**

Myrica emarginata Heer, Flora fossilis arctica, vol. 6, Abt. 2, p. 66, pl. 41, fig. 2, 1882.

Lesquereux, The flora of the Dakota group, p. 67, pl. 12, fig. 1, 1892.

Newberry, The flora of the Amboy clays, p. 62, pl. 41, figs. 10, 11, 1896.

Berry, New Jersey Geol. Survey Bull. 3, p. 104, pl. 10, fig. 5, 1911; U. S. Geol. Survey Prof. Paper 112, p. 73, pl. 13, fig. 4, 1920.

Heer's description, published in 1882, is as follows:

M. foliis oblongis, integerrimis, apice emarginatis, basi attenuatis, nervis secundariis subtilissimis.

This species, which was described from specimens collected in the Atane beds of Greenland, has been recorded from the Raritan and Tuscaloosa formations of the Atlantic Coastal Plain and from the Dakota sandstone of the Western Interior. It is somewhat variable in form but may be characterized as follows:

Leaves obovate, widest at the rounded, truncate, and more or less emarginate apex, with entire margins narrowing to the cuneate base. Midrib mediumly stout. Secondaries, five thin pairs, subopposite, diverging from the midrib at angles of about 45°, camptodrome.

The reference of this species to the genus *Myrica* is entirely problematic. It is astonishingly close to a form from Niederschoena, Saxony, described by Engelhardt¹⁷ as *Mimusops ballotaevides*.

***Myrica longa* (Heer) Heer.**

Plate XXXIX, figure 5.

Proteoides longus Heer, Flora fossilis arctica, vol. 3, Abt. 2, p. 110, pl. 29, fig. 8b; pl. 31, figs. 4, 5, 1874.

Dawson, Roy. Soc. Canada Trans., vol. 1, sec. 4, p. 22, pl. 2, fig. 8, 1883.

Fric, Archiv naturw. Landes. Böhmen, vol. 4, No. 1, pp. 18, 94, 1878.

Myrica longa (Heer) Heer, Flora fossilis arctica, vol. 6, Abt. 2, p. 65, pl. 18, fig. 9b; pl. 29, figs. 15-17; pl. 33, fig. 10; pl. 41, fig. 4d, 1882; vol. 7, p. 21, 1883.

Lesquereux, U. S. Geol. Survey Mon. 17, p. 67, pl. 3, figs. 1-6, 1892.

Bartsch, Iowa Univ. Lab. Nat. Hist. Bull., vol. 3, p. 180, 1896.

Knowlton, U. S. Geol. Survey Twenty-first Ann. Rept., pt. 7, p. 314, pl. 39, fig. 7, 1901.

Berry, Torrey Bot. Club Bull., vol. 33, p. 170, 1906; Maryland Geol. Survey, Upper Cretaceous, p. 812, pl. 57, figs. 1-3, 1916; Torrey Bot. Club Bull., vol. 44, p. 175, 1917; U. S. Geol. Survey Prof. Paper 112, p. 74, 1919.

Leaves of various sizes, linear to lanceolate, with a stout midrib, numerous thin, ascending, camptodrome secondaries, entire margins, obtusely pointed apex, narrowly decurrent base, and long, stout petiole.

This species, which Heer described as a *Proteoides* and subsequently transferred to the genus *Myrica*, has a particularly wide

¹⁶ Saporta, Gaston de, Contributions à la flore fossile du Portugal, p. 176, pl. 31, fig. 14, 1894.

¹⁷ Engelhardt, Hermann, Naturwiss. Gesell. Isis in Dresden Abh. 7 Jahrg. 1891, p. 98, pl. 2, fig. 13, 1892.

distribution. It occurs in both the Atane and Patoot beds of western Greenland, in the Dakota sandstone of the West, in the Magothy formation of Maryland, and in the Bingen sand of Arkansas and is very common in the Tuscaloosa formation in western central Alabama. Abroad it has been recorded from the lower Turonian of Bohemia. Dawson recorded it from Peace River in Northwest Territory.

It occurs in the Dakota sandstone in Woodbury County, Iowa, in Ellsworth County, Kans., and near Lander, Wyo. It is thus a member of the true Dakota sandstone flora. This is also emphasized by its distribution in the Upper Cretaceous of the Atlantic Coastal Plain.

Although abundant this species lacks good diagnostic characters, and its botanical affinity is therefore uncertain. Its relation to *Myrica* is extremely doubtful.

Order SALICALES.

Family SALICACEAE.

Genus SALIX Linné.

Salix lesquereuxii Berry.

Salix lesquereuxii Berry, Torrey Bot. Club Bull., vol. 36, p. 252, 1909; vol. 37, pp. 21, 194, 1910; New Jersey Geol. Survey Bull. 3, p. 114, 1911; U. S. Geol. Survey Prof. Paper 84, pp. 33, 109, pl. 7, figs. 11-13, 1914; Maryland Geol. Survey, Upper Cretaceous, p. 814, pl. 58, figs. 5-8, 1916; Torrey Bot. Club Bull., vol. 44, p. 176, 1917; U. S. Geol. Survey Prof. Paper 112, p. 76, 1919.

Salix proteaefolia Lesquereux, Am. Jour. Sci., 2d ser., vol. 46, p. 94, 1868 (not Forbes); The Cretaceous flora, p. 60, pl. 5, figs. 1-4, 1874; The Cretaceous and Tertiary floras, p. 42, pl. 1, figs. 14-16, pl. 16, fig. 3, 1883; The flora of the Dakota group, p. 49, 1892.

Newberry, The flora of the Amboy clays, p. 66, pl. 18, figs. 3, 4, 1896.

Kurtz, Mus. La Plata Rev., vol. 10, p. 51, 1902.

Berry, New Jersey Geol. Survey Ann. Rept. for 1905, p. 139, 1906; Torrey Bot. Club Bull., vol. 33, p. 171, pl. 7, fig. 2, 1906; Johns Hopkins Univ. Circ., new ser., No. 7, p. 81, 1907.

Salix proteaefolia longifolia Lesquereux, The flora of the Dakota group, p. 50, pl. 44, fig. 9, 1892.

Bartsch, Iowa Univ. Lab. Nat. Hist. Bull., vol. 3, p. 179, 1896.

Protoides daphnoides Heer, Newberry, The flora of the Amboy clays, p. 72 (part), pl. 32, fig. 11, 1896.

Devalquea groenlandica Heer, Newberry, The flora of the Amboy clays, p. 129 (part), pl. 41, fig. 12, 1896.

Leaves ovate-lanceolate, somewhat more acuminate above than below, variable in size,

ranging from 6 to 12 centimeters in length and from 1.1 to 2.2 centimeters in greatest width, which is usually slightly below the middle. Petiole stout, much longer than in *Salix flexuosa*, having a maximum length of 1.2 centimeters. Midrib stout below, tapering above. Secondaries numerous, in some specimens as many as 20 pairs; they branch from the midrib at angles of about 45° and are subparallel and camptodrome.

This species is exceedingly variable, as might be expected in a *Salix*, and Lesquereux established several varieties, of which at least one, *linearifolia*, is referable to *Salix flexuosa* Newberry. Some of Lesquereux's forms are distinguishable with difficulty from *Salix flexuosa*, and this is especially shown in the leaves which he figures on Plate I of his "Cretaceous and Tertiary floras." They are, however, larger and somewhat more robust, of a thicker texture and broadest near the base, from which they taper upward to an exceedingly acuminate tip. In general *Salix lesquereuxii* is a relatively much broader, more ovate form, with more numerous and better seen secondaries and a longer petiole.

This species is an exceedingly abundant Upper Cretaceous type in both the East and the West, ranging chronologically in the Coastal Plain from the base of the Raritan formation to the top of the Tuscaloosa formation, and possibly through the Eutaw formation as well. It is abundant in the Magothy and Black Creek formations, including the Middendorf arkose member of the Black Creek. It is widespread from the bottom to the top of the Tuscaloosa formation in Alabama and occurs in the Bingen sand of Arkansas. In the West it is a member of the Dakota sandstone flora and is not present in the older Cheyenne sandstone flora, nor is it known from beds younger than the Dakota sandstone in that region. It is one of the forms recorded by Kurtz from the Upper Cretaceous of Argentina, indicating, if the identification is correct, which is doubtful, a very considerable migration during early Upper Cretaceous time.

Recently Knowlton¹⁸ has tentatively identified this species from the type section of the Morrison formation in Colorado.

¹⁸ Knowlton, F. H., Am. Jour. Sci., 4th ser., vol. 49, p. 190, 1920.

* *Salix deleta* Lesquereux.

Salix deleta Lesquereux, U. S. Geol. Survey Mon. 17, p. 49, pl. 3, fig. 8, 1891 [1892].

Leaves ovate-lanceolate and subfalcate, widest below the middle and tapering gradually upward to the bluntly pointed tip and downward to the cuneate inequilateral base. Margins entire. Texture subcoriaceous. Length about 8.5 centimeters, maximum width about 2.7 centimeters. Midrib stout and prominent. Secondaries numerous, diverging from the midrib at angles of about 50°, subparallel, camptodrome. Areolation quadrangular.

This species was described originally by Lesquereux from Pipe Creek, Cloud County, Kans., and so far as known is confined to the Dakota sandstone and the Woodbine sand. Its relationship to the genus *Salix* is extremely problematic and, in my judgment, is far from demonstrated. The leaf has the appearance of a leaflet of some member of the Sapindaceae, but the amount of material available for study is insufficient to warrant final conclusions.

Genus *POPULUS* Linné.*Populus harkeriana* Lesquereux.

Populus harkeriana Lesquereux, U. S. Geol. Survey Mon. 17, p. 44, pl. 46, fig. 4, 1891 [1892].

Hollick, New York Acad. Sci. Annals, vol. 2, p. 419, pl. 36, fig. 8, 1898; U. S. Geol. Survey Mon. 50, p. 49, pl. 7, fig. 31, 1906.

Berry, Torrey Bot. Club Bull., vol. 39, p. 394, 1912.

This species was described by Lesquereux from material collected in the Dakota sandstone at Fort Harker, Kans., and was subsequently recorded by Hollick from the Cretaceous material (Raritan or Magothy) in the terminal moraine near Tottenville, Staten Island. The collection from Arthurs Bluff, Tex., contains a single specimen and its counterpart, showing half of a large typical leaf of this species. There is also an undeterminable species of the *Populus* type in the collection.

Order *URTICALES*.Family *MORACEAE*.Genus *FICUS* Linné.*Ficus daphnogenoides* (Heer) Berry.

Plate XXXIX, figure 1.

Proteoides daphnogenoides Heer, Phyllites crétacées du Nebraska, p. 17, pl. 4, figs. 9, 10, 1866.

Lesquereux, The Cretaceous flora, p. 85, pl. 15, figs. 1, 2, 1874; The flora of the Dakota group, p. 90, 1892.

Hollick, New York Acad. Sci. Trans. vol. 11, p. 98, pl. 3, figs. 1, 2, 1892; vol. 12, p. 36, pl. 2, figs. 4, 9, 13, 1893; Torrey Bot. Club Bull., vol. 21, p. 52, pl. 177, fig. 1, 1894; The Cretaceous flora of southern New York and New England, p. 59, pl. 12, figs. 1-5, 1906.

Smith, On the geology of the Coastal Plain of Alabama, p. 348, 1894 (determined by Ward).

Newberry, The flora of the Amboy clays, p. 72, pl. 17, figs. 8, 9; pl. 32, figs. 11, 13, 14; pl. 33, fig. 3; pl. 41, fig. 15, 1896.

Berry, New York Bot. Garden Bull., vol. 3, p. 74, pl. 51, figs. 6-9, 1903.

Ficus daphnogenoides (Heer) Berry, Torrey Bot. Club Bull., vol. 32, p. 327, pl. 21, 1905; vol. 33, p. 173, pl. 7, fig. 5, 1906; vol. 34, p. 194, pl. 11, figs. 10, 11, 1907; New Jersey Geol. Survey Bull. 3, p. 122, pl. 12, fig. 4, 1911; Torrey Bot. Club Bull., vol. 39, p. 394, 1912; vol. 44, p. 177, 1917; Maryland Geol. Survey, Upper Cretaceous, p. 818, pl. 58, fig. 3, 1916; U. S. Geol. Survey Prof. Paper 112, p. 80, pl. 13, figs. 6, 7, 1919.

Ficus proteoides Lesquereux, The flora of the Dakota group, p. 77, pl. 12, fig. 2, 1892.

Eucalyptus? attenuata Newberry, The flora of the Amboy clays, pl. 16, fig. 5 (not figs. 2, 3), 1896.

Heer's description, published in 1866, is as follows:

Les feuilles sont coriaces, à la base atténuées, entières; la nervure médiane est forte; elle porte deux nervures secondaires faibles, acrodromes, qui sont presque parallèles au limbe; mais elles ne sont pas opposées, comme chez les *Daphnogene* et *Cinnamomum*.

This species was described by Heer from very incomplete material found in the Dakota sandstone of Nebraska. His specimens have some long ascending secondaries, but Lesquereux's more complete specimens from the same formation and region show that these secondaries were not acrodrome but camptodrome. The species in this feature and also in other respects differs from *Protea* and its allies, which are more coriaceous and have the secondaries branching at acute angles and massed toward the generally apetiolate base. It closely resembles a number of different existing species of *Ficus* from such widely separated localities as Central and South America and Celebes. Especially among the Mexican and Central American forms are very similar leaves seen—for example, *Ficus fasciculata* Watson, *Ficus lancifolia* Hooker and Arnott, *Ficus ligustrina* Kunth and Bouché, and especially *Ficus sapida* Miquel, which has much the same outline and consistency, the same prominent midrib, and the same venation. When the fossil forms are placed in

the genus *Ficus*, where they properly belong, they find their affinity in the group which includes, among others, such fossil species as *Ficus elongata* Hosius, *Ficus berthoudi* Lesquereux, *Ficus suspecta* Velenovsky, and *Ficus krausiana* Heer.

This species has been found to be variable in size, ranging in length from 11 to 22 centimeters and in width from 1.9 to 3.7 centimeters. It is usually widest in the lower half of the leaf, although in some specimens the base is narrow and the widest part is toward the middle. In all unequivocal material the upper half of the leaf is narrow and is produced as a long, slender, commonly recurved tip, which is one of the characteristic features of the species. This tip is strictly comparable with the "dripping points" developed on various modern leaves in the regions where precipitation is heavy.

Ficus daphnogenoides is a widespread and common form, ranging from Marthas Vineyard to Alabama, Arkansas, and Texas in the Atlantic Coastal Plain and from the Northwest Territory to Kansas and Nebraska in the Western Interior region.

It is a member of the Dakota sandstone flora and does not occur in the older Cheyenne sandstone so far as my observations go. It was reported by Ward from the Cheyenne sandstone at Chatman Creek, Kans., but Ward's material, which I have before me, is not this species but a leaflet of *Sapindopsis*. Knowlton¹⁹ has recently tentatively identified this form from the type section of the Morrison formation at Morrison, Colo. The species is not uncommon in the Woodbine sand at Arthurs Bluff, Tex.

Ficus glascoeana Lesquereux.

Ficus glascoeana Lesquereux, U. S. Geol. Survey Terr. Rept., vol. 8 (Cretaceous and Tertiary floras), p. 48, 1883; U. S. Geol. Survey Mon. 17, p. 76, pl. 13, figs. 1, 2, 1891 [1892].

Knowlton, U. S. Geol. Survey Twenty-first Ann. Rept., pt. 7, p. 317, 1901.

Leaves large, oblong-ovate in general outline, with an obtusely pointed apex and a broadly rounded or cuneate, ultimately slightly decurrent base. Length from 18 to 20 centimeters; maximum width, at or below the middle, 6.5 to 7.5 centimeters. Margins entire. Texture coriaceous. Surface polished. Peti-

ole missing. Midrib very stout and prominent on the under surface of the leaf. Secondaries numerous, thin, diverging from the midrib at wide angles, subparallel, straight, ascending, joining one another by abrupt curves subparallel with and close to the margins.

This species, which is of the same general type as *Ficus atavina* Heer,²⁰ was described by Lesquereux from material collected 2½ miles south of Glascoe, Kans. So far as known it is confined to the Dakota sandstone and to the Woodbine sand at Arthurs Bluff, Tex., and the remains were usually much broken before fossilization. *Ficus atavina*, which is closely related to it, was also a stiff form, usually found in a broken condition. It has an extensive range, occurring in the Atane and Patoot beds of Greenland, the Magothy formation and the Middendorf arkose member of the Black Creek formation in the Atlantic Coastal Plain, the Turonian of Bohemia, and the Gosau beds of Tyrol. It seems very probable that *Ficus glascoeana* is genetically related to the more widely distributed *Ficus atavina*.

Order PLATANALES.

Family PLATANACEAE.

Genus PLATANUS Linné.

Platanus latior (Lesquereux) Knowlton.

Platanus accroides? Goeppert var. *latior* Lesquereux, Am. Jour. Sci., 2d ser., vol. 46, p. 97, 1868.

Platanus latior (Lesquereux) Knowlton, U. S. Geol. Survey Bull. 152, p. 170, 1898; U. S. Geol. Survey Twenty-first Ann. Rept., pt. 7, p. 314, 1901.

Berry, U. S. Geol. Survey Prof. Paper 112, p. 84, 1920.

Platanus primacca Lesquereux, The Cretaceous flora, p. 69, pl. 7, fig. 2; pl. 26, fig. 2, 1874; The flora of the Dakota group, p. 72, pl. 8, figs. 7, 8b; pl. 10, fig. 1, 1892.

Leaves large, palmately trilobate, broadly rhomboidal. Length about 17 centimeters; maximum width about 15 centimeters. Margins somewhat irregularly dentate, entire at the broadly cuneate base. Lateral lobes short; intervening sinuses scarcely differentiated. Petiole long and stout. Primaries stout, three in number, diverging at or near the base in the material from Alabama but commonly supra-basilar in the forms from the Dakota sandstone. Venation strictly platanoid. Texture coriaceous.

¹⁹ Knowlton, F. H., Am. Jour. Sci., 4th ser., vol. 49, p. 190, 1920.

²⁰ Heer, Oswald, Flora fossilis arctica, vol. 6, Abt. 2, p. 69, pl. 11, figs. 5b, 7b, 8b; pl. 17, fig. 8b; pl. 19, fig. 1b; pl. 20, figs. 1, 2, 1882.

This fine large species is very abundant in the Dakota sandstone of Kansas, Nebraska, and Minnesota, and Lesquereux differentiated three varieties, *integrifolia*, *subintegrifolia*, and *grandidentata*.

Order RANALES.

Family MAGNOLIACEAE.

Genus MAGNOLIA Linné.

Magnolia speciosa Heer.

Plate XL, figure 6.

Magnolia speciosa Heer, Allg. schweiz. Gesell. gesamt. Naturwiss. Bern Neue Denschr., Band 23, p. 20, pl. 6, fig. 1; pl. 9, fig. 2; pl. 10, fig. 1, 1869.

Lesquereux, The Cretaceous and Tertiary floras, p. 72, 1874; The flora of the Dakota group, p. 202, pl. 60, figs. 3, 4, 1892.

Hollick, New York Acad. Sci. Trans., vol. 12, p. 234, pl. 7, fig. 4, 1893; Torrey Bot. Club Bull., vol. 21, p. 60, pl. 178, fig. 5, 1894; Geol. Soc. America Bull., vol. 7, p. 13, 1895; The Cretaceous flora of southern New York and New England, p. 64, pl. 19, figs. 1-4, 1906.

Knowlton, U. S. Geol. Survey Twenty-first Ann. Rept., pt. 7, p. 318, 1901.

Smith, On the geology of the Coastal Plain of Alabama, p. 348, 1894.

Berry, Torrey Bot. Club Bull., vol. 31, p. 76, pl. 3, fig. 10, 1904; vol. 32, p. 46, pl. 2, figs. 4, 5, 1905; New Jersey Geol. Survey Bull. 3, p. 129, pl. 14, fig. 3, 1911; Torrey Bot. Club Bull., vol. 39, p. 395, 1912; U. S. Geol. Survey Prof. Paper 112, p. 88, pl. 18, figs. 3, 4, 1919.

Magnolia auriculata Newberry, The flora of the Amboy clays, p. 75 (part), pl. 41, fig. 13; pl. 58, fig. 10, 1896.

Heer's description, published in 1869, is as follows:

M. foliis maximis, coriaceis, ovato-ellipticis, apice longe attenuatis, valde acuminatis, basi in petiolum validum attenuatis, nervo primario crasso, nervis secundariis valde curvatis, camptodromis.

This species is somewhat variable in size. The American material, which is somewhat smaller than the type material from Moravia, ranges in length from 8.5 to 19 centimeters and in maximum width from 4 to 7.5 centimeters. It is ovate-elliptical, with the apex more or less produced and the base decurrent. The midrib and petiole are stout. The secondaries are well marked, camptodrome; they number seven to nine pairs and are subopposite, branching from the midrib at

angles of about 45° and curving upward. The texture is coriaceous.

This species, which was described originally from specimens collected in the Cenomanian of Moravia, has a wide range in America. Typical leaves occur in the Dakota sandstone. It is present on Marthas Vineyard and Long Island and in the Raritan and Magothy formations of New Jersey. It is present at Arthurs Bluff, Tex., and was recorded by Knowlton from the Woodbine at Rhamey Hill, Denison, Tex.

Magnolia lacoena Lesquereux.

Magnolia lacoena Lesquereux, The flora of the Dakota group, p. 201, pl. 60, fig. 1, 1892.

Newberry, The flora of the Amboy clays, p. 73, pl. 55, figs. 1, 2, 1896.

Hollick, The Cretaceous flora of southern New York and New England, p. 65, pl. 17, fig. 2, 1906.

Berry, Torrey Bot. Club Bull., vol. 37, p. 23, 1910; New Jersey Geol. Survey Bull. 3, p. 134, pl. 16, fig. 2, 1911; Maryland Geol. Survey, Upper Cretaceous, p. 832, pl. 70, figs. 1, 2, 1916; U. S. Geol. Survey Prof. Paper 112, p. 91, pl. 17, fig. 9, 1919.

Leaves broadly oval to almost orbicular, obtuse or abruptly pointed above and rounded to a somewhat cuneate base below. 10 to 12 centimeters in length by 8.5 to 9.5 centimeters in maximum width. Midrib stout, somewhat flexuous. Secondaries numerous, camptodrome, rather stout, 10 to 12 pairs; they branch from the midrib at acute angles, immediately curving outward, forming festoons near the margin, which is somewhat undulate in one specimen that Newberry referred to this species.

This species differs from its contemporaries, especially in its nearly round outline. Lesquereux finds a resemblance to *Magnolia ingfieldi* Heer, from Greenland, and it also suggests some of the Arctic forms which have been referred to *Magnolia capellini* Heer.

Although this species is reported from points so widely separated as Marthas Vineyard and Kansas, it is nowhere abundant and is usually poorly preserved, suggesting that the leaves were readily macerated. It also occurs in the Magothy formation of New Jersey and Maryland and the Tuscaloosa formation of Alabama. The type locality was Ellsworth County, Kans., and the range elsewhere of this species would indicate that this locality was in the true Dakota sandstone.

Genus **LIRIODENDRON** Linné.**Liriodendron quercifolium** Newberry.

Plate XXXVI, figure 3.

Liriodendron quercifolium Newberry, Torrey Bot. Club Bull., vol. 14, p. 6, pl. 62, fig. 1, 1887; U. S. Geol. Survey Mon. 26, p. 81, pl. 51, figs. 1-6, 1896.

Berry, New Jersey Geol. Survey Bull. 3, p. 138, pl. 17, fig. 1, 1911; Torrey Bot. Club Bull., vol. 39, p. 395, 1912; vol. 44, p. 182, 1917.

Liriodendron pinnatifidum? Knowlton (not Lesquereux), U. S. Geol. Survey Twenty-first Ann. Rept. pt. 7, p. 317, 1901.

Liriodendron snowii Knowlton (not Lesquereux), idem.

Leaves oblong, large, pinnately divided by narrow sinuses into two to four lateral lobes. Apex emarginate. Base truncate to somewhat cordate. Length along the midrib 7 to 9 centimeters and probably considerably more in some specimens, as one fragment measures 12 centimeters in width. Width in perfect specimens about 9 centimeters. Lateral lobes ovate, with very acute tips, some narrowed proximad, giving them an almost obovate outline; intervening lateral sinuses narrow and deeply cut, some reaching nearly to the midrib, rounded. Some specimens have only two main lobes developed on each side and are then very similar to the typical modern leaf of *Liriodendron tulipifera*. In these specimens, however, the upper lobes are divided by a shallow sinus into two acute lobules. Other specimens show three lobes of equal magnitude on each side, and one of the best specimens from the Woodbine sand has four nearly equal lobes on each side, the basal and apical pairs being somewhat shorter than the medial pairs. This form of leaf is very suggestive of some species of *Quercus*, but its variations, as well as its venation, show that it is related to *Liriodendron*. The petiole is preserved for a considerable length and is very stout, as is the midrib. There is one main secondary traversing each lobe and running directly to its apical point. In addition there are one or more camptodrome secondaries in each lobe which anastomose with branches from the main secondary, their number being dependent upon the relative width of the lobe; they branch from the midrib at angles of about 60°.

At first sight this species appears to differ considerably from *Liriodendron oblongifolium* and from the modern form, but this difference is not nearly as great as it seems, and it is probable that *Liriodendron quercifolium* is simply a variation from the common ancestor

of the two species in the direction of *Liriodendron pinnatifidum* Lesquereux. Numerous leaves of the modern tree can be found with an incipient lobation suggesting *Liriodendron quercifolium*. In these leaves, however, the sinus is comparatively shallow and rounded, so that the general appearance of the two is not markedly similar.

Knowlton recorded *Liriodendron pinnatifidum* and *Liriodendron snowii* from the Woodbine sand, but both of these prove to be fragments of this species.

Family **TROCHODENDRACEAE**.Genus **TROCHODENDROIDES** Berry, n. gen.

This genus is proposed as a form genus for fossil leaves that appear to be referable to the family Trochodendraceae. It is perhaps best, for the present, not to attempt a definition. Attention is called in a recent publication²¹ to the possibility that certain Mesozoic forms of dicotyledons commonly referred to *Celastrphyllum*, *Populus*, and *Populophyllum* represented ancestral forms of *Tetracentron*, *Trochodendron*, and *Cercidophyllum*. A great many Cretaceous plant species have been referred to the existing genus *Populus*, and the evidence for such a relationship is very slight in a number of forms, particularly among the older ones. The plant from the Dakota sandstone described by Lesquereux as *Phyllites rhomboideus*, which is present in the Woodbine sand, is here considered the type of the genus and is for the present the only species definitely assigned to it. A critical survey of the late Lower Cretaceous and early Upper Cretaceous dicotyledons would result in transferring a number of forms to *Trochodendroides*, which may serve for the reception of any fossil species of the family.

Trochodendroides rhomboideus (Lesquereux) Berry.

Plate XXXVI, figure 5.

Ficus? rhomboideus Lesquereux, Am. Jour. Sci., 2d ser., vol. 46, p. 96, 1868.

Phyllites rhomboideus Lesquereux, Cretaceous flora, p. 112, pl. 6, fig. 7, 1874.

Knowlton, U. S. Geol. Survey Twenty-first Ann. Rept., pt. 7, p. 317, 1901.

This species was described by Lesquereux from material found in the Dakota sandstone at Decatur, Nebr. He at first referred it with a query to *Ficus*, which it obviously does not represent. Subsequently he transferred it to

²¹ Berry, E. W., Am. Jour. Sci., 4th ser., vol. 50, p. 49, 1920.

Phyllites, and in his account of 1874 he suggested comparisons with *Smilax*, *Paliurus*, and *Populus*. It has no characters which ally it to *Smilax* or *Paliurus*, but it is much like a variety of species that have been referred to *Populus*, the majority of which do not present clear evidence to warrant such a reference.

The species may be described as follows: Leaves rhomboidal to orbicular, with a rounded or cuneate decurrent base, presumably varying to more or less cordate. Apex broadly rounded. Margins entire in their lower halves, undulate toothed in their distal halves. Texture subcoriaceous. Length about 4.5 to 6 centimeters; maximum width, midway between the apex and the base, 5 to 6.5 centimeters. Petiole stout, curved, 2 centimeters in length in the smaller leaves, not preserved in the larger. Venation five-palmate from the base, the midrib no stouter than the lateral primaries; they diverge at acute angles and arch near the upper margin to join branches from the short camptodrome secondaries. Areolation obsolete.

In form and venation the fossil is much like the modern leaves of both *Tetracentron* and *Cercidophyllum*, especially seedling leaves; it is less like *Trochodendron* but is approached by seedling leaves of that genus. If, as some botanists believe, these somewhat anomalous vesselless dicotyledons are primitive in their features and not reduced, they should be present among the earlier fossil angiosperms and should show considerable abundance and diversity. The abundance of comparable fossil forms, as I have pointed out, masquerading under various names and widespread and abundant in the closing days of the Lower Cretaceous, in a measure substantiates the first of these assumptions.

Family RANUNCULACEAE?

Genus DEWALQUEA Saporta and Marion.

Dewalquea insigniformis Berry.

Dewalquea insigniformis Berry, Torrey Bot. Club Bull., vol. 44, p. 179, pl. 7, figs. 6, 7, 1917.

Leaves digitate, of probably five leaflets. Leaflets linear-acuminate, with prominently serrate margins. Length about 12 centimeters; maximum width mostly 1 to 1.25 centimeters, at or slightly above the middle. Base very gradually narrowed and with entire margins for a distance of about 2 centimeters. Midrib stout, prominent on the under surface

of the leaflets. Secondaries numerous, diverging from the midrib at angles of 30° to 40°, long ascending and eventually camptodrome, sending off small outwardly directed branches to the marginal teeth. Texture coriaceous.

This characteristic species with its coriaceous texture must have had rather stiff, strict leaves in life. It adds to our flora another form of the curious genus *Dewalquea*, which is so striking an element in the Upper Cretaceous and lower Eocene. The only known American species that resembles this form in any respect is *Dewalquea smithi* Berry,²² of the Tuscaloosa and Black Creek formations. *D. smithi* is much larger, with relatively broader leaflets, which have less prominently serrate margins and partly craspedodrome venation.

Dewalquea insigniformis is, however, as its name indicates, very much like *Dewalquea insignis* Hosius and Von der Marck,²³ a prominent species in the Campanian and Maestrichtian substages of Europe. *D. insignis* has relatively broader, less prominently toothed leaflets, in some specimens as many as seven, and the venation is said to be craspedodrome. The venation is, however, a character of slight value, for entire and toothed leaflets generally occur together, and I imagine that *Dewalquea insignis* is merely a serrate form of the associated *Dewalquea haldemiana* Saporta and Marion. If the latter had prominent serrate teeth added it would be identical with *Dewalquea insigniformis*.

Dewalquea insigniformis was described from a large number of fragmentary specimens obtained in the upper part of the Bingen sand in Pike County, Ark. A characteristic leaflet is present in the early collections from the Woodbine sand at Arthurs Bluff, Tex.

Order ROSALES.

Family CAESALPINIACEAE.

Genus PALEOCASSIA Ettingshausen.

Paleocassia laurinea Lesquereux.

Plate XI, figure 8.

Paleocassia laurinea Lesquereux, The flora of the Dakota group, p. 147, pl. 64, fig. 12, 1892.

Berry, Torrey Bot. Club Bull., vol. 39, p. 396, 1912; U. S. Geol. Survey Prof. Paper 112, p. 100, pl. 23, fig. 1, 1919.

Leaflets ovate-lanceolate, subinequilateral, with a pointed apex and a cuneate base. Length

²² Berry, E. W., Torrey, vol. 10, pp. 34-38, fig. 1, 1910.

²³ Hosius, A., and Von der Marck, W., Palaeontographica, vol. 26, p. 172, pl. 32, figs. 111-113; pl. 33, fig. 109; pl. 34, fig. 110; pl. 35, fig. 123, 1880.

from 3 to 6 centimeters; maximum width, at or below the middle, about 2 centimeters. Margins entire, somewhat irregular. Petiolule short, curved, gradually enlarged proximad, about 5 millimeters in length. Midrib of medium size, curved. Secondaries thin, camp-todrome.

This species was described from specimens collected in the Dakota sandstone of Kansas and is present in the lower part of the Tuscaloosa formation in Alabama. As interpreted by Lesquereux, its describer, the remains represented leaflets of a *Cassia*-like plant, although so far as I know all have been detached, the only basis for considering them leaflets rather than leaves being their slight inequilateral form.

A single entire leaflet is contained in the collection from Arthurs Bluff, Tex. It is identical with the type material from Kansas in size, outline, and venation, with the exception that it is slightly wider (2 to 5 millimeters), with a consequently somewhat fuller and more rounded base.

Family **PAPILIONACEAE.**

Genus **COLUTEA** Linné.

Colutea primordialis Heer.

- Colutea primordialis* Heer, Flora fossilis arctica, vol. 6, Abt. 2, p. 99, pl. 27, figs. 7-11; pl. 63, figs. 7, 8, 1882. Lesquereux, U. S. Geol. Survey Mon. 17, p. 148, pl. 13, figs. 8, 9, 1891 [1892]. Newberry, U. S. Geol. Survey Mon. 26, p. 97, pl. 19, figs. 4, 5, 1896. Hollick, U. S. Geol. Survey Mon. 50, p. 84, pl. 32, figs. 14, 15, 1906. Berry, Torrey Bot. Club Bull., vol. 37, p. 24, 1910; vol. 38, p. 407, 1911; vol. 39, p. 396, 1912; New Jersey Geol. Survey Bull. 3, p. 156, pl. 20, fig. 4, 1911; Maryland Geol. Survey, Upper Cretaceous, p. 845, pl. 75, fig. 3, 1916; Torrey Bot. Club Bull., vol. 44, p. 184, 1917.

This species was described from material found in the Atane beds of western Greenland and was subsequently recorded from the Dakota sandstone near Delphos, Kans., the Raritan formation of New Jersey, and the Magothy formation of Marthas Vineyard, Long Island, and Maryland. It is represented by a single specimen in the collection from the upper member of the Bingen sand, and by a single

complete and in every way typical leaflet from Arthurs Bluff, Tex.

The reference of this and other American Upper Cretaceous species to the Old World genus *Colutea* may well be questioned, and it is probable that they represent some other leguminous genus with similar foliage.

Order **SAPINDALES.**

Family **SAPINDACEAE.**

Genus **SAPINDUS** Linné.

Sapindus morrisoni Heer.

- Sapindus morrisoni* Heer, Flora fossilis arctica, vol. 6, Abt. 2, p. 896, pl. 40, fig. 1; pl. 41, fig. 3; pl. 43, figs. 1a, b; pl. 44, figs. 7, 8, 1882. Lesquereux, U. S. Geol. Survey Terr. Rept., vol. 8 (Cretaceous and Tertiary floras), p. 83, pl. 16, figs. 1, 2, 1883; U. S. Geol. Survey Mon. 17, p. 158, pl. 35, figs. 1, 2, 1892. Hollick, New York Acad. Sci. Annals, vol. 11, p. 422, pl. 36, fig. 4, 1898; U. S. Geol. Survey Mon. 50, p. 90, pl. 33, figs. 16-20, 1906. Knowlton, U. S. Geol. Survey Twenty-first Ann. Rept., pt. 7, p. 317, 1901. Berry, New York Bot. Garden Bull., vol. 3, p. 83, pl. 47, figs. 2, 3, 1903; Torrey Bot. Club Bull., vol. 31 p. 78, 1904; vol. 39, p. 396, 1912; vol. 44, p. 186, 1917; New Jersey Geol. Survey Ann. Rept., 1905, p. 138, 1906; U. S. Geol. Survey Prof. Paper 84, p. 49, pl. 9, fig. 6, 1914; Prof. Paper 112, p. 112, 1919.

Leaflets of variable, usually large size, lanceolate and more or less inequilateral, with a broadly cuneate or rounded base and a pointed apex. Petiolulate. Texture subcoriaceous. Margins entire. Midrib stout, curved. Secondaries numerous, camp-todrome.

The present species was described originally as from the Atane beds of western Greenland by Heer, to whom it must be credited, although it was based on Lesquereux's manuscript, which appeared in print the following year. It is common in the Dakota sandstone at a number of widely scattered localities and in the Magothy formation of the northern Atlantic Coastal Plain and the Tuscaloosa formation of the eastern Gulf area. It is not uncommon in both the lower and upper members of the Bingen sand of Arkansas, and fragmentary specimens occur in both the earlier and later collections from Arthurs Bluff, Tex.

Family ANACARDIACEAE.

Genus RHUS Linné.

Rhus reddiformis Berry.

Plate XXXVII, fig. 2.

Rhus reddiformis Berry, Torrey Bot. Club Bull., vol. 39, p. 397, pl. 31, fig. 2, 1912.

Leaves compound, probably trilobate. Leaflets petiolate, ovate, with bluntly pointed tips-cuneate bases, and entire or undulate margins forming a few distal shallow, broadly rounded lobules separated by broad, shallow sinuses. Terminal leaflet nearly equilateral, about one, third larger than the lateral leaflets, about 4 centimeters in length by 2 centimeters in maximum width, which is about midway between the apex and the base; petiole 5 millimeters long; midrib stout, prominent; secondaries thin, five or six alternate pairs, branching from the midrib at angles of about 50°, curving slightly upward, anastomosing close to the entire margin. Lateral leaflets inequilateral, the outer limb of the lamina being slightly wider and fuller than the inner limb; petioles shorter than that of the terminal leaflet, 2 to 3 millimeters in length, diverging from the latter at angles of about 70°; in outline and venation similar to the terminal leaflet, but smaller and showing a tendency to develop slight irregularities in the margin, especially toward their tips.

This species was named from its rather striking resemblance to the European early Tertiary species *Rhus reddita* Saporta,²⁴ from Aix, in southeastern France. Several Cretaceous species of *Rhus* have been described from specimens found in beds as old as the Woodbine, the Dakota sandstone of Kansas having furnished three supposed species with pinnate leaves, one of which, *Rhus uddeni* Lesquereux,²⁵ was erroneously reported by Ward from the Cheyenne sandstone at Belvidere, Kans. The Cheyenne form proves to be a species of *Sapindopsis*, and this may also be the botanic affinity of the type material of *Rhus uddeni*.

A small-toothed species from the Cenomanian sandstone of Bohemia has been described by Velenovsky²⁶ as *Rhus cretacea*, although this

name was already in use for a very different Cretaceous species described by Heer²⁷ from material obtained in the Senonian at Quedlinburg, in Saxony, and recorded by Hollick²⁸ from the Upper Cretaceous of Long Island. The Woodbine species is readily distinguishable from all the foregoing and adds a well-marked and probably trifoliate Cretaceous form to this genus, which was so largely developed during Tertiary time. In the existing flora *Rhus* is a prominent element with more than 150 species, most of which are natives of warm temperate and tropical regions.

A modern species with almost identical foliage is the South African *Rhus villosa* Linné.

Order RHAMNALES.

Family RHAMNACEAE.

Genus RHAMNUS Linné.

Rhamnus tenax Lesquereux.

Plate XL, figure 7.

Rhamnus tenax Lesquereux, Am. Jour. Sci., 2d ser., vol. 46, p. 101, 1868; The Cretaceous flora, p. 109, pl. 21, fig. 4, 1874; The flora of the Dakota group, p. 170, pl. 38, fig. 6, 1892.

Engelhardt, Naturwiss. Gesell. Isis in Dresden Abh. 7, Jahrg. 1891, p. 101, 1892.

Bartsch, Iowa Univ. Lab. Nat. Hist. Bull., vol. 3, p. 181, 1896.

Berry, Torrey Bot. Club Bull., vol. 39, p. 398, 1912; U. S. Geol. Survey Prof. Paper 112, p. 114, pl. 25, figs. 1, 2, 1919.

Leaves ovate-lanceolate, acuminate, slightly equilateral. Length about 8 centimeters; maximum width about 2 centimeters in the lower half of the leaf. The dimensions of these leaves are remarkably uniform in all the specimens from the Dakota sandstone of the West, as well as in those from the Tuscaloosa formation in Alabama. Margins entire, curving inward somewhat abruptly to the petiole, which is stout, more or less curved, and about 1 centimeter or slightly more in length. Midrib stout, curved, becoming thin in the acuminate tip. Secondaries numerous, thin, approximately parallel, 12 to 14 subopposite to alternate pairs, branching from the midrib at angles of about 45° to 50°, curving slightly upward, camptodrome.

This species, which was described many years ago by Lesquereux from material col-

²⁴ Saporta, Gaston de, Études sur la végétation du sud-est de la France à l'époque tertiaire, tome 1, p. 124, pl. 13, figs. 2, a, b, 1862.

²⁵ Lesquereux, Leo, U. S. Geol. Survey Mon. 17, p. 154, pl. 57, fig. 2, 1892.

²⁶ Velenovsky, Josef, Die Flora der böhmische Kreideformation, pt. 4, p. 7, pl. 4, figs. 7-12, 1885.

²⁷ Heer, Oswald, Zur Kreidelfora von Quedlinburg, p. 14, pl. 3, fig. 11, 1872.

²⁸ Hollick, Arthur, U. S. Geol. Survey Mon. 50, p. 87, pl. 33, fig. 2, 1907.

lected in the Dakota sandstone of southern Kansas and subsequently recorded by Bartsch from the same formation in Iowa, is represented in the lower beds of the Tuscaloosa formation of western Alabama and in the Woodbine sand at Arthurs Bluff, Tex., by leaves which are identical in all their characters with the type material and which seem to be closely allied to the Tertiary and modern forms of *Rhamnus*. It has been reported by Engelhardt from the Cenomanian of Niederschoena, Saxony, but this record may well be considered doubtful.

Genus **ZIZYPHUS** Adanson.

Zizyphus lamarensis Berry.

Plate XXXVI, figure 4.

Zizyphus lamarensis Berry, Torrey Bot. Club Bull., vol. 39, p. 398, pl. 31, fig. 1, 1912; U. S. Geol. Survey Prof. Paper 112, p. 112, 1919.

Leaves elliptical, 4.5 to 5 centimeters in length by 3 centimeters in maximum width, about midway between the apex and the base, though slightly nearer the base; base full and rounded; lateral margins full and rounded; apex rounded, slightly less full than the base; margin with regular but shallow crenate teeth, becoming less prominent toward the base. Midrib slender but prominent, straight. Lateral primaries one on each side, diverging from the midrib at its extreme base at an acute angle (about 10°), thin, slightly curved inward above the middle, joining a secondary in the apical part of the leaf. Secondaries from the midrib two or three alternate thin pairs in the apical region, camptodrome; secondaries from the lateral primaries five or six in number, on the outside, curved, camptodrome; the lowest secondary is longest and branches at the most acute angle (about 10°) and from the extreme base; each successively higher secondary subtending a slightly larger angle and following a somewhat shorter course. Internal tertiaries more or less percurrent, marginal ones similar to the secondaries from the primaries in their arrangement and course, thin and camptodrome.

This handsome species of an undoubted *Zizyphus* was described recently from very scanty material obtained in the Woodbine sand of Texas. It is entirely distinct from any previously described Cretaceous species and is much closer to some of the Tertiary and still existing forms.

Zizyphus has not yet been discovered in the European Cretaceous, but it is represented in the Western Hemisphere by four or five well-marked types. The nearest to the present species is *Z. groenlandicus* Heer,²⁹ which occurs in the Magothy formation on Marthas Vineyard and in the Patoot beds of western Greenland. It is of about the same size but relatively wider than the Texas form and has a somewhat different venation and much coarser teeth. The species from the Magothy of New Jersey, *Z. cliffwoodensis* Berry,³⁰ is a larger, lanceolate, entire-margined form. The two species from the Cretaceous of Long Island, *Z. elegans*³¹ and *Z. oblongus*,³² described by Hollick, are much smaller, entire-margined forms, and Hollick's *Z. lewisiana*,³³ another Cretaceous species from the same locality, is a small lanceolate leaf of doubtful affinity.

The existing species of *Zizyphus* number about 40 and are largely indigenous in the Indo-Malayan region, although the genus is represented in subtropical or tropical America, Africa, and Australia. One modern species, *Zizyphus vulgaris* Lamarck, an oriental form, has foliage almost identical with *Z. lamarensis*, the outline, margin, and venation being the same.

Family **VITACEAE**.

Genus **CISSITES** Heer.

Cissites formosus Heer.

Plate XL, figure 5.

Cissites formosus Heer, Flora fossilis arctica, vol. 6, pt. 2, p. 85, pl. 21, figs. 5-8, 1882.

Lesquereux, The flora of the Dakota group, p. 161, pl. 21, fig. 5, 1892.

Hollick, Torrey Bot. Club Bull., vol. 21, p. 57, pl. 174, fig. 6, 1894; The Cretaceous flora of southern New York and New England, p. 94, pl. 37, fig. 7, 1906.

Newberry, The flora of the Amboy clays, p. 107, pl. 47, figs. 1-8, 1896.

Berry, New Jersey Geol. Survey Bull. 3, p. 185, 1911; U. S. Geol. Survey Prof. Paper 112, p. 115, 1919.

Heer's description, published in 1882, is as follows:

C. foliis palmatis, profunde trilobatis, lobo medio basi contracto, trilobato, lobis obtusis.

²⁹ Heer, Oswald, Flora fossilis arctica, vol. 7, p. 42, pl. 62, fig. 20, 1883.

³⁰ Berry, E. W., Johns Hopkins Univ. Circ., new ser., No. 7, p. 88, fig. 5, 1907.

³¹ Hollick, Arthur, Torrey Bot. Club Bull., vol. 21, pl. 176, fig. 9, 1894.

³² Hollick, Arthur, The Cretaceous flora of southern New York and New England: U. S. Geol. Survey Mon. 50, p. 92, pl. 34, figs. 9, 10, 1907.

³³ Hollick, Arthur, Torrey Bot. Club Bull., vol. 21, p. 58, pl. 180, fig. 13, 1894.

This description was based upon very fragmentary material from the Atane beds of Greenland, from which, nevertheless, Heer reconstructed the supposed outline of the perfect leaf. To judge by the specimens referred to this species by Lesquereux and Newberry it was an exceedingly variable form. In plan it is trilobate, but the subsidiary lobes developed upon both the median and the lateral lobes in some specimens obscure this trilobate character and suggest *Cissites parvifolius* Berry, of the Albian of America and Europe; *Cissites dentatolobatus* Lesquereux, of the Dakota sandstone; *Cissites panduratus* Knowlton, of the Vermejo, Mesaverde, and Ripley formations; or *Cissus vitifolia* Velenovsky, of the Cenomanian of Bohemia.

The primaries are stout and three in number; they may diverge from the top of the stout petiole or be suprabasilar; in many specimens the branches of the laterals approach so near the base that the leaves have the appearance of being palmately 5-veined.

This species is common but fragmentary in the Raritan formation; it ranges from 7 to 10 centimeters in length and from 6 to 12 centimeters between the tips of the main lateral lobes. The sinuses are all rounded, and the main ones may be deep or shallow. The fragment from Long Island referred to this species by Hollick is, as he remarks, exceedingly unsatisfactory and doubtful. The species occurs also in the Dakota sandstone of Kansas, and a closely related variety has been found in the Magothy formation of Maryland. Typical material is present in the Tuscaloosa formation of Alabama. It is represented by a scanty amount of incomplete material at Arthurs Bluffs, Tex.

The genus *Cissites* was erected by Heer in 1866 for the species *Cissites insignis*, from the Dakota sandstone of Nebraska, which presented points of affinity with the genus *Cissus* of Linné. It is a largely developed type in the upper half of the Cretaceous system but was replaced after Eocene time by forms which are definitely referable to modern allied genera such as *Cissus* and *Vitis*.

Order MALVALES.

Family STERCULIACEAE.

Genus STERCULIA Linné.

Sterculia lugubris Lesquereux?

Plate XXXVI, figure 6.

Sterculia lugubris Lesquereux, The Cretaceous and Tertiary floras, p. 81, pl. 6, figs. 1-3, 1883.

Berry, Torrey Bot. Club Bull., vol. 39, p. 399, pl. 31, fig. 2, 1912.

Leaves variable in size, often large, deeply palmately trilobate. Length from 12 to 24 centimeters. Texture coriaceous. Margins entire. Base cuneate, decurrent. Lobes narrow linear-lanceolate, acuminate. Primaries three, stout, prominent, diverging from the top of the thick petiole at acute angles. Secondaries thin, camptodrome, mostly immersed in the thick substance of the leaf.

This striking species was described from specimens collected in the so-called Dakota sandstone near Golden, Colo. It is very similar to *Sterculia cliffwoodensis* Berry,³⁴ of the Magothy formation of New Jersey and Delaware.

This species is apparently represented at Arthurs Bluff, Tex., by the single specimen figured, which agrees very well with the Dakota sandstone forms of *Sterculia lugubris*. The reference is queried, as the specimen may represent an exceedingly slender, elongated, almost parallel-margined form of *Aralia wellingtoniana* Lesquereux, which is so common at this locality.

Order THYMELEALES.

Family LAURACEAE.

Genus BENZOIN Fabricius.

Benzoin venustum (Lesquereux) Knowlton.

Plate XXXVIII, figure 2.

Landera venusta Lesquereux, U. S. Geol. Survey Mon. 17, p. 95, pl. 16, figs. 1, 2, 1892.

Benzoin venustum (Lesquereux) Knowlton, U. S. Geol. Survey Bull. 152, p. 47, 1898.

Berry, Torrey Bot. Club Bull., vol. 39, p. 399, 1912.

Leaves of variable size, trilobate, separated by narrow ultimately rounded sinuses about

³⁴ Berry, E. W., New York Bot. Garden Bull., vol. 3, p. 88, pl. 43, fig. 5, 1903.

halfway to the base into three ovate erect lobes, which are rather bluntly or conically pointed. The median lobe is largest and most expanded medianly. The margins are entire, and the lower lateral margins are full and rounded. The base is more or less decurrent. The leaf substance is thin. Length from 4 to 10 centimeters; maximum width, about halfway between the apex and the base, from 3.5 to 9 centimeters. Petiole missing in all the known material. Midrib stout, normally straight. A single stout lateral primary diverges from the midrib at an acute angle at its extreme base on either side and terminates at the tip of the lateral lobe. The secondaries are thin, numerous, ascending, and camptodrome, the basal lateral secondaries being especially long and ascending, the others being subparallel. Tertiaries mostly percurrent, open.

This species, which shows considerable resemblance to some of the Upper Cretaceous forms that have been referred to the genus *Sassafras*, was described from material collected in the Dakota sandstone of Ellsworth County, Kans. Small leaves are abundant in the characteristic concretionary specimens, which I believe represent the true Dakota sandstone rather than older beds in that area. The species is not abundant in the Woodbine sand, but there are several specimens in the relatively small collections from that formation, to which and the Dakota this form appears to be confined.

Genus **MALAPOENNA** Adanson.

Malapoenna falcifolia (Lesquereux) Knowlton.

Litsea falcifolia Lesquereux, The flora of the Dakota group, p. 97, pl. 11, fig. 5, 1892.

Malapoenna falcifolia (Lesquereux) Knowlton, U. S. Geol. Survey Bull. 152, p. 142, 1898.

Berry, Torrey Bot. Club Bull., vol. 33, p. 180, 1906; New Jersey Geol. Survey Ann. Rept. for 1905, p. 139, 1906; Torrey Bot. Club Bull., vol. 39, p. 399, 1912; U. S. Geol. Survey Prof. Paper 112, p. 122, pl. 21, fig. 5, 1919.

Leaves of relatively small size, lanceolate, falcate. Length about 5 to 6 centimeters; maximum width, about halfway between the apex and the base, if anything slightly nearer the base, about 1.7 centimeters; from this point the blade narrows to the lanceolate base and gradually tapers to the extended acuminate tip. Petiole not preserved. Midrib much

curved, thin distad. Secondaries three or four pairs; the lower suprabasilar and subopposite pair should possibly be termed lateral primaries, as Lesquereux called them. These lower secondaries are thin and branch from the midrib at angles of 45° or less, sweeping upward in a long curve, at length camptodrome. Upper secondaries somewhat irregularly spaced, camptodrome. Tertiaries very fine and more or less obsolete. Texture coriaceous but not thick.

This attractive species is easily distinguished from other lauraceous forms, particularly from species of *Cinnamomum*, with which Lesquereux originally compared it, by its slight inequilaterality and marked falcate form, as well as by the lack of definiteness in the triple venation, the suprabasilar position of the so-called primaries, and the character of the tertiary venation. It was described originally from material found in the Dakota sandstone near Delphos, Kans., and subsequently was discovered by me in the Magothy formation of New Jersey. Some of the specimens from the lower part of the Tuscaloosa formation of Alabama, though the material is not extensive, are complete and are entirely characteristic, as is the single specimen discovered at Arthurs Bluff, Tex. It may readily be distinguished from *Malapoenna horrellensis* Berry,³⁵ of the Upper Cretaceous Black Creek, Eutaw, and Ripley formations, by its suprabasilar primaries and cuneate base.

Genus **OREODAPHNE** Nees.

Oreodaphne alabamensis Berry.

Plate XXXVII, figure 1.

Oreodaphne alabamensis Berry, Torrey Bot. Club Bull., vol. 39, p. 400, pl. 32, 1912; U. S. Geol. Survey Prof. Paper 112, p. 119, pl. 19, figs. 3-5, 1919.

Leaves of large size, ovate, from 13 to 20 cubic centimeters in length and from 4.75 to 7 cubic centimeters in maximum width, which is at a point midway between the apex and the base. From the point of greatest width the margins curve, both distad and proximad, in a very full curve, narrowing rather abruptly to the acuminate tip and also to the more or less decurrent base. Midrib stout, curved. Lateral primaries opposite, one on each side, branching from the midrib at an acute angle a considerable distance above its base, rather

³⁵ Berry, E. W., Torrey Bot. Club Bull., vol. 37, p. 198, pl. 24, figs. 1-9, 1910.

straight in their course, thinner than the midrib. Above the primaries there is an interval, and then about six pairs of thin, curved, approximately parallel camptodrome secondaries branch from the midrib at acute angles. The lateral primaries give off on the outside numerous regularly spaced and approximately parallel curved camptodrome secondaries, the latter feature serving to distinguish this species from other fossil species of this genus and from *Cinnamomum*, *Cocculus*, or other genera having somewhat similar leaves, with which it might be compared. Texture coriaceous.

This fine large species is represented at Arthurs Bluff, Tex., by fragmentary but characteristic specimens. The description was largely drawn up from abundant and complete material from the Tuscaloosa formation of western Alabama. The specimens show considerable variation in size and some in outline, the leaf being widest either nearer to or farther from the base. In the latter form the distal part is more fully rounded and abruptly contracted to the acuminate tip, while the base is more gradually narrowed and finally cuneate rather than decurrent. In the former the apical part is more gradually narrowed and the base is full and rounded abruptly, decurring to the petiole.

This species is markedly different from other described fossil forms but may be matched by several modern tropical American species of *Oreodaphne*. The genus *Oreodaphne* of Nees, which is exclusively American in the existing flora, is made a subgenus of *Ocotea* Aublet by Pax in Engler and Prantl's "Die natürlichen Pflanzenfamilien." The genus *Ocotea*, which for paleobotanic purposes may be considered as composite, has about two hundred modern species occurring chiefly in the American Tropics and ranging from southern Florida to Brazil and Peru but having some representatives (subgenus *Mespilodaphne* Nees) in the Canary Islands, South Africa, Madagascar, and the Mascarene Islands.

The single existing American species reaching the United States whose habit and environment may be taken as typical for the whole genus is found in Florida, southward from Capes Canaveral and Romano, along the shores and islands, except on some of the western keys, making its best growth in the rich, moist hammock lands near the coast.

Genus CINNAMOMUM Blume.

Cinnamomum newberryi Berry.

Plate XXXIX, figure 3.

- Cinnamomum sezannense* Heer, Flora fossilis arctica, vol. 6, Abt. 2, p. 77, pl. 19, fig. 8; pl. 33, figs. 11, 12, 1882 (not Watelet); vol. 7, p. 30, pl. 41, fig. 1a, 1883.
- Lesquereux, The flora of the Dakota group, p. 107, pl. 12, fig. 7, 1892 (not fig. 6).
- Dawson, Roy. Soc. Canada Trans., 1st ser., vol. 2, sec. 4, p. 64, pl. 13, fig. 58, 1894.
- Hollick, Torrey Bot. Club Bull., vol. 21, p. 53, pl. 180, figs. 5, 7, 1894.
- Penhallow, Roy. Soc. Canada Trans., 2d ser., vol. 8, sec. 4, p. 46, 1902.
- Hollick, New York State Mus. Fifty-fifth Ann. Rept., for 1901, p. r50, 1903.
- Cinnamomum intermedium* Newberry. Smith, On the geology of the Coastal Plain of Alabama, p. 348, 1894 (nomen nudum) (not Ettingshausen).
- Newberry, The flora of the Amboy clays, p. 89, pl. 29, figs. 1-8, 1896.
- Berry, New Jersey Geol. Survey Ann. Rept. for 1905, p. 139, pl. 20, figs. 2-6, 1906; Torrey Bot. Club Bull., vol. 33, p. 179, pl. 7, figs. 3, 4; vol. 37, p. 27, 1910.
- Hollick, The Cretaceous flora of southern New York and New England, p. 74, pl. 29, fig. 7; pl. 30, figs. 1, 2, 1906.
- Cinnamomum newberryi* Berry, Torrey Bot. Club Bull., vol. 38, p. 423, 1911; New Jersey Geol. Survey Bull. 3, p. 150, pl. 16, fig. 3, 1911; U. S. Geol. Survey Prof. Paper 84, pp. 54, 117, pl. 9, figs. 12, 13; pl. 21, figs. 9-11, 1914; Maryland Geol. Survey, Upper Cretaceous, p. 860, pl. 71, fig. 6, 1916; U. S. Geol. Survey Prof. Paper 112, p. 118, pl. 21, figs. 6-9, 1919.
- Cinnamomum* n. sp.? Knowlton, U. S. Geol. Survey Twenty-first Ann. Rept., pt. 7, p. 317, 1901.

Leaves subcoriaceous, lanceolate to ovate-lanceolate, differing greatly in size and consequently in appearance. Apex short-pointed or more or less narrowly extended; base broad, narrowed to the petiole. Primaries three, usually suprabasilar.

This species is primarily distinguished from *Cinnamomum heerii* Lesquereux, which Knowlton³⁶ recorded from the Woodbine sand of Cooke County, Tex., by its relatively narrower form and acute base. The present species, as revised according to the foregoing citations, has a remarkable range in the Upper Cretaceous. It is recorded from the Raritan formation of New Jersey, the oldest formation in which it has been found. Above the Raritan it occurs in the Atane and Patoot beds of Greenland, in the Magothy formation from Long

³⁶ Knowlton, F. H., in Hill, R. T., Geography and geology of the Black and Grand prairies, p. 318, 1901.

Island to Maryland, in the Black Creek formation of North Carolina, in the Middendorf arkose member of the Black Creek formation of South Carolina, in the Bingen sand of Arkansas, in the Tuscaloosa formation of Georgia and Alabama, in the Eutaw formation of Georgia, in the Ripley formation of Tennessee, and in the Dakota sandstone of Kansas. It appears to be present in the Upper Cretaceous of the Pacific coast on Vancouver Island and to be represented in Texas by the remains of *Cinnamomum* recorded by Knowlton³⁷ from the Woodbine sand in Cooke County. Although not known from Europe, the forms from the Cenomanian of Bohemia which Velenovsky³⁸ described as *Aralia daphnophyllum* are very similar to the American species.

The specimens found in the Dakota sandstone came from Ellsworth County, Kans., and the range elsewhere of this species seems to prove that the formation was the true Dakota sandstone rather than some older sandstone.

It seems obvious that the range of this form represents more than a single botanic species, as no question of correlation is involved in the eastern Gulf section from Tuscaloosa to Ripley, but the only criteria for segregation are stratigraphic. The leaves of *Cinnamomum*, both living and fossil, are notoriously variable, so that the problem appears insoluble.

The species is not abundant in the Woodbine material from Arthurs Bluff, Tex., but I regard this scarcity as merely an accident of preservation or discovery.

***Cinnamomum membranaceum* (Lesquereux) Hollick.**

Paliurus membranaceus Lesquereux, Am. Jour. Sci., 2d ser., vol. 46, 1868, p. 101; U. S. Geol. Survey Terr. Rept., vol. 6 (Cretaceous flora), p. 108, pl. 20, fig. 6, 1874; U. S. Geol. Survey Mon. 17, p. 167, pl. 35, fig. 5, 1891 [1892].

Cinnamomum membranaceum Hollick, U. S. Geol. Survey Mon. 50, p. 75, pl. 29, figs. 5, 6, 1906.

Berry, Torrey Bot. Club Bull., vol. 39, p. 401, 1912.

This species, which Lesquereux referred to the genus *Paliurus*, was described originally from specimens collected at Decatur, Nebr., and Pipe Creek, Kans. It occurs in the northward extension of the Magothy formation at Gay Head, Marthas Vineyard, Mass., and in the Woodbine sand at Arthurs Bluff, Tex. I

think that Hollick was entirely justified in removing this form from *Paliurus*, but I am not sure that it is a *Cinnamomum*, although it appears to be a lauraceous form. If a *Cinnamomum*, as is perfectly possible, it should probably be regarded as a variant of the contemporaneous *Cinnamomum newberryi*, from which it differs merely in its irregularity of outline.

Genus LAURUS of authors.

***Laurus plutonia* Heer.**

Plate XXXVIII, figure 5.

Laurus plutonia Heer, Flora fossilis arctica, vol. 6, Abt. 2, p. 75, pl. 19, figs. 1d, 2-4; pl. 20, figs. 3a, 4, 5; pl. 24, fig. 6b; pl. 28, figs. 10, 11; pl. 42, fig. 4b, 1882; vol. 7, p. 30, pl. 58, fig. 2; pl. 62, fig. 1a, 1883.

?Velenovsky, Die Flora der böhmische Kreideformation, pt. 3, p. 1, pl. 4, figs. 2-4, 1884.

Lesquereux, U. S. Geol. Survey Mon. 17, p. 91, pl. 13, figs. 5, 6; pl. 22, fig. 5, 1892; Minnesota Geol. and Nat. Hist. Survey, vol. 3, pt. 1, p. 14, pl. A, fig. 6; pl. B, fig. 5, 1895.

Newberry, U. S. Geol. Survey Mon. 26, p. 85, pl. 16, figs. 10, 11, 1896.

?Frič and Bayer, Naturw. Landes. Böhmen Archiv, vol. 11, No. 2, p. 130, fig. 94, 1901.

Berry, New York Bot. Garden Bull., vol. 3, p. 79, pl. 1, figs. 9-11, 1903; Torrey Bot. Club Bull., vol. 31, p. 77, pl. 3, fig. 1, 1904; vol. 33, p. 178, 1906; vol. 39, p. 401, 1912; New Jersey Geol. Survey-Ann. Rept. for 1905, pp. 138, 139, 1906; U. S. Geol. Survey Prof. Paper 84, p. 52, pl. 11, fig. 2; pl. 12, fig. 6, 1914; Maryland Geol. Survey, Upper Cretaceous, p. 861, pl. 71, fig. 5, 1916; U. S. Geol. Survey Prof. Paper 112, p. 123, 1919.

Hollick, U. S. Geol. Survey Mon. 50, p. 80, pl. 27, figs. 9, 10, 1906; New York Bot. Garden Bull., vol. 8, p. 162, pl. 169, figs. 3-5, 1912.

Leaves lanceolate, usually tapering almost equally in both directions but some specimens less acute at the base. Length, 7 to 11 centimeters; greatest width, 1.5 to 2.5 centimeters. Midrib fairly stout. Petiole short and stout, 6 to 15 millimeters in length. Secondaries slender, eight or more alternate pairs, campitodrome.

This species was described by Heer from material collected in the Atane beds of western Greenland, and a large number of somewhat variable and fragmentary specimens were figured. Subsequently it was recorded from a very large number of Cretaceous plant beds, so that its range both geographic and geologic is rather extensive. A number of these records are not entirely above suspicion, and this

³⁷ Knowlton, F. H., idem.

³⁸ Velenovsky, Josef, Die Flora der böhmische Kreideformation, pt. 2, p. 10, pl. 7, figs. 5-8, 1882.

appears to be especially true of the forms from the Cenomanian of Bohemia identified by Velenovsky.

Laurus plutonia is uncommon in the Raritan formation, and I have found it only near the top. It is abundant in the overlying Magothy formation from New Jersey to Maryland. In the southern Coastal Plain it occurs in the Middendorf arkose member of the Black Creek formation of South Carolina and ranges from the base of the Tuscaloosa formation upward into the Eutaw formation in the Alabama area. It was identified by Ward from the Cheyenne sandstone of Chatman Creek, Kans., but his material, which I have studied, is not this species but represents leaflets of *Sapindopsis*.

A single complete and characteristic leaf and several fragments are contained in the collections from Arthurs Bluff, Tex.

***Laurus antecedens* Lesquereux?**

Laurus antecedens Lesquereux, U. S. Geol. Survey Mon. 17, p. 92, pl. 11, fig. 3, 1891 [1892].

Hollick, U. S. Geol. Survey Mon. 50, p. 80, pl. 28, figs. 9, 10, 1906.

This species, the type locality of which is simply "Dakota sandstone of Kansas (Lacoe collection)," is at best of doubtful validity. It was described by Lesquereux as follows:

Leaf membranous, lanceolate, gradually tapering to the apex, narrowed to the base, not decurrent, somewhat curved to one side, entire, irregularly undulate; median nerve thick; secondaries oblique, curved, parallel, but of unequal thickness and distance, camptodrome. The leaf is 11 centimeters long, 2.5 centimeters broad below the middle, slightly inequilateral by the partial contraction of the borders on one side, and is not gradually narrowed to the petiole but somewhat rounded in narrowing to it. Its precise relation is not satisfactorily ascertained.

The Texas material is fragmentary and of doubtful identity.

Genus LAUROPHYLLUM Goepfert.

***Laurophyllum minus* Newberry.**

Laurophyllum minus Newberry, U. S. Geol. Survey Mon. 26, p. 87, pl. 17, figs. 7-9, 1895 [1896].

Berry, N. J. Geol. Survey Bull. 3, p. 149, 1911; Torrey Bot. Club Bull., vol. 39, p. 402, 1912.

This species, which is of doubtful validity, was described from material collected in the Raritan formation of New Jersey, and I have found it only in the upper part of that formation. In the absence of venation characters

in both the type and later collected material its identification is always more or less uncertain; and it may represent a variety of *Laurus plutonia* Heer or some of the forms that have been referred to *Myrica longa* Heer, although in general it is wider than the latter and more elongated and less symmetrical than the former. A single specimen is present in the collection from Arthurs Bluff, Tex.

Order MYRTALES.

Family MYRTACEAE.

Genus MYRTONIUM Ettingshausen.

***Myrtonium geinitzi* (Heer) Berry.**

Myrtophyllum geinitzi Heer, Kreideflora von Moletein in Mähren, p. 22, pl. 11, figs. 3, 4, 1872; Flora fossilis arctica, vol. 3, Abt. 2, p. 116, pl. 32, figs. 14-17, 1874. Frič, Naturw. Landes. Böhmen Archiv, vol. 4, No. 1, pp. 18, 94, 1878.

Hollick, New York Acad. Sci. Trans., vol. 12, p. 236, pl. 6, fig. 2, 1893.

Myrtophyllum warderi Lesquereux, U. S. Geol. Survey Mon. 17, p. 136, pl. 53, fig. 10, 1892.

Hollick, U. S. Geol. Survey Mon. 50, p. 97, pl. 35, fig. 13, 1906.

Eucalyptus? angustifolia Newberry, U. S. Geol. Survey Mon. 26, p. 111, pl. 32, figs. 1, 6, 7, 1896.

Hollick, New York Bot. Garden Bull., vol. 3, p. 408, pl. 70, figs. 8, 9, 1894; U. S. Geol. Survey Mon. 50, p. 95, pl. 35, figs. 9, 14, 15, 1906.

Eucalyptus geinitzi Heer, Flora fossilis arctica, vol. 6, Abt. 2, p. 93, pl. 19, fig. 1c; pl. 45, figs. 4-9; pl. 46, figs. 12c, d, 13, 1882.

Engelhardt, Naturwiss. Gesell. Isis in Dresden Abh. 7, p. 102, 1891.

Lesquereux, U. S. Geol. Survey Mon. 17, p. 138, pl. 37, fig. 20, 1892.

Newberry, U. S. Geol. Survey Mon. 26, p. 110, pl. 32, figs. 2, 12, 15, 16, 1896.

Krasser, Beiträge zur Kenntniss der fossilen Kreideflora von Kunstadt in Mähren, p. 22, 1896.

Frič and Bayer, Naturw. Landes. Böhmen Archiv, vol. 11, No. 2, p. 142, fig. 110, 1901.

Berry, New York Bot. Garden Bull., vol. 3, p. 87, pl. fig. 3, 1903; Torrey Bot. Club Bull., vol. 31, p. 78, pl. 4, fig. 5, 1904; vol. 33, p. 180, 1906; vol. 34, p. 201, pl. 15, fig. 4, 1907; vol. 37, p. 26, 1910; vol. 39, p. 402, 1912; New Jersey Geol. Survey Ann. Rept. for 1905, p. 138, 1906.

Hollick, U. S. Geol. Survey Mon. 50, p. 96, pl. 35, figs. 1-8, 10-12, 1906.

Hollick, New York Bot. Garden Bull., vol. 8, p. 166, pl. 180, figs. 1, 2, 1912.

Berry, U. S. Geol. Survey Prof. Paper 84, p. 56, pl. 13, figs. 8-12; pl. 14, fig. 1, 1914; New Jersey Geol. Survey Bull. 3, p. 189, 1911; Maryland Geol. Survey, Upper Cretaceous, p. 870, pl. 81, figs. 1-5, 1916; U. S. Geol. Survey Prof. Paper 112, p. 126, pl. 28, fig. 8, 1919.

This widespread and characteristic Upper Cretaceous species is found in this country from the base of the Raritan formation of New Jersey upward into the Black Creek formation of the Carolinas. Abroad it is common in the Cenomanian and ranges upward into the Turonian. The type locality is in the Cenomanian of Moravia, but the species has also been recorded from the Atane beds of western Greenland and from the Dakota sandstone of the West. In the Alabama Cretaceous it has been collected only from the lower part of the Tuscaloosa formation.

Several characteristic specimens are present in the collections from Arthurs Bluff, Tex. This species was recorded by Ward from the Cheyenne sandstone at Chatman Creek, Kans., but the material upon which the record was based is referable to the genus *Sapindopsis*.

Order **UMBELLALES.**

Family **ARALIACEAE.**

Genus **ARALIA** Linné.

***Aralia wellingtoniana* Lesquereux.**

Plate XXXVII, figure 3; Plate XXXVIII, figures 3, 4.

Aralia wellingtoniana Lesquereux, U. S. Geol. Survey Mon. 17, p. 131, pl. 21, fig. 1 (pl. 22, figs. 2, 3, is not this species but *Aralia saportana* Lesquereux), 1891 [1892].

Newberry, U. S. Geol. Survey Mon. 35, p. 114, pl. 26, fig. 1, 1895 [1896].

Berry, New Jersey Geol. Survey Bull. 3, p. 202, pl. 25, fig. 7, 1911; Torrey Bot. Club Bull., vol. 39, p. 402, 1912.

Aralia concinna Newberry, U. S. Geol. Survey Mon. 16, p. 114, 1895 [1896].

Aralia wellingtoniana vaughanii Knowlton, U. S. Geol. Survey Twenty-first Ann. Rept., pt. 7, p. 317, 1901.

This handsome species is described by Lesquereux as being palmately three to five lobed, but it certainly seems significant that all the forms from the Raritan formation are three-lobed and that the five-lobed forms from the Dakota sandstone referred by Lesquereux to this species are indistinguishable from his species *Aralia saportana*, which occurs at the same horizon and, in part at least, at the same locality.

This is the most abundant form collected at Arthurs Bluff, Tex., there being 15 specimens in the one small collection made by Stanton and Stephenson and as many more in the old

collections made by Hill and Vaughan. These are all trilobate, and the majority have toothed margins and agree exactly with the Raritan leaves of this species and with the trilobate leaves from the Dakota sandstone like the one figured by Lesquereux on his Plate XXI, figure 1.

In the light of our present knowledge *Aralia wellingtoniana* may be redescribed in the following terms:

Leaves variable in size, 10 to 20 centimeters in length by 8 to 15 centimeters in maximum width from tip to tip of the lateral lobes; average size about 15 centimeters in length by 11 centimeters in width; coriaceous, palmately deeply trilobate, with a rapidly narrowed and more or less extended decurrent base; lobes long, lanceolate, widest in the middle and narrowing below, somewhat abruptly acuminate, the medium slightly the longest, diverging at an angle of about 30°, separated by sinuses extending more than halfway to the base, narrowly rounded; margins entire below and for varying distances upward, sometimes throughout, generally passing gradually into dentate-serrate teeth, one to each secondary or less, prominent in some specimens, where they are more or less extended and directed upward, separated by wide, shallow sinuses. Primaries stout, suprabasilar, the median slightly larger than the laterals. Secondaries numerous, thin, regular, subparallel, ascending, as the angle of their divergence from the primaries averages about 33°, but slightly curved in their course, ultimately craspedodrome in the distal parts of the leaf, where the margin is toothed, and camptodrome in the basal half of the leaf, where the margin is entire. Areolation indistinct, reticulate, of quadrangular or polygonal meshes. The smaller leaves are relatively shorter and broader, with less extended lobes and more open and less deep sinuses.

The present species was confused by Ward³⁹ with what was subsequently differentiated as *Aralia cottondalensis* Berry,⁴⁰ of the Tuscaloosa formation, which has shorter, more conical lobes, a broadly rounded base, and more crenate marginal teeth.

³⁹ Ward, L. F., in Smith, E. A., Geology of the Coastal Plain of Alabama, p. 348, 1894.

⁴⁰ Berry, E. W., U. S. Geol. Survey Prof. Paper 112, p. 128, pl. 26, figs. 1-3, 1919.

The present species is also very similar to *Aralia decurrens* Velenovsky,⁴¹ from the Cenomanian of Bohemia, which, however, has relatively narrower and more elongated lobes, with coarser teeth, and deeper sinuses.

In reporting on a collection made by Vaughan at Arthurs Bluff, Tex., and now in the United States National Museum, Knowlton⁴² mentions *Aralia wellingtoniana vaughanii* n. var. as the most abundant form observed. This variety was distinguished from the type "by its trilobate form, more slender lobes, and entire margins." A study of this material has satisfied me that it is not distinct from the normal *Aralia wellingtoniana*, which shows every gradation in size and ranges from entire to more or less completely toothed margins.

***Aralia saportana* Lesquereux?**

Aralia saportana Lesquereux, U. S. Geol. and Geog. Survey Terr. Bull., vol. 1, p. 394, 1875 [1876]; idem, Ann. Rept. for 1874, p. 350, pl. 1, figs. 2, 2a, 1876; U. S. Geol. Survey Terr. Rept., vol. 8 (Cretaceous and Tertiary floras), p. 61, pl. 8, figs. 1, 2; pl. 9, figs. 1, 2, 1883.

Aralia wellingtoniana Lesquereux, Flora of the Dakota group, p. 131 (part), pl. 22, figs. 2, 3 (not pl. 21, fig. 1), 1892.

This species was described by Lesquereux as follows:

Leaves large, subcoriaceous, triple-nerved and five-lobate by division of the lateral nerves, fan-shaped in outline, narrowed in a curve or broadly cuneate, and decurring to a long, slender petiole; lobes narrowly lanceolate or linear-lanceolate, acute or blunt at the apex, equally diverging, distantly dentate from below the middle upward; secondary nerves subcamptodrome.

This beautiful species is known by numerous finely preserved specimens. The leaves, 9 to 20 centimeters long from the top of the petiole to the summit of the middle lobe, are of the same width between the points of the lower lateral lobes; the petiole is long and comparatively slender, though appearing thick upon one of the specimens, probably enlarged and flattened by compression. The preserved broken part on one of the leaves measures 5 centimeters. The lobes cut down to about two-thirds of the leaves are narrowly lanceolate, slightly narrower near the obtuse sinuses, equally diverging, the lower lateral ones much shorter, curved down, and decurring to the base of the leaves. The leaves, triple-nerved from the division of the primary nerves a little above the base, become five-nerved from the forking of the lateral nerves at a short distance from their base. The secondary veins emerge at an acute angle of 30°, curve in ascending to the borders, and sometimes enter the teeth by their ends; the upper more generally follows close to the borders in fes-

toons, emitting under the teeth short branches which enter them. There are not any intermediate tertiary veins, but the nervilles are strong, often continuous, anastomosing in the middle of the areas and forming by subdivisions a small quadrangular areolation.

The material from Arthurs Bluff, Tex., is scanty and not positively determined.

Family CORNACEAE.

Genus CORNOPHYLLUM Newberry.

***Cornophyllum vetustum* Newberry.**

Cornophyllum vetustum Newberry, The flora of the Amboy clays, p. 119, pl. 19, fig. 10, 1896.

Berry, New Jersey Geol. Survey Bull. 3, p. 196, 1911; Torrey Bot. Club Bull., vol. 39, p. 404, 1912; U. S. Geol. Survey Prof. Paper 112, p. 129, 1919.

Leaves elliptical, 7 to 8 centimeters in length by about 4 centimeters in maximum width, with an acute apex and base, the base slightly decurrent and inequilateral. Margin entire, very slightly and inconspicuously undulate. Midrib slender and straight. Secondaries slender, about seven pairs, opposite or alternate, branching from the midrib at angles of about 45° and strongly curved upward, approximately parallel and camptodrome; they increase in length from the apex to the base, the lower ones sweeping upward in strong arches parallel with the margin and all drawn inward toward the apex.

With the exception of the delicate and somewhat flexuous character of the venation, these leaves are strictly comparable with those of *Cornus*, good species of which, very similar to this species, occur in the Dakota sandstone of the West, in Greenland, and in the Magothy formation of Maryland.

This species is found also in the Raritan formation of New Jersey and the Tuscaloosa formation of Alabama.

Order ERICALES?

Family ERICACEAE?

Genus ANDROMEDA Linné.

***Andromeda novaecaesareae* Hollick.**

Plate XXXVIII, figure 1.

Andromeda novaecaesareae Hollick, in Newberry, The flora of the Amboy clays, p. 121, pl. 42, figs. 9-12, 28-31, 1896.

Smith, On the geology of the Coastal Plain of Alabama, p. 348, 1894.

Berry, Torrey Bot. Club Bull., vol. 33, p. 181, 1906; vol. 34, p. 204, 1907; vol. 37, p. 29, 1910; vol. 39, p. 405, 1912; vol. 43, p. 301, 1916; vol. 44, p. 188, 1917; New Jersey Geol. Survey Bull. 3, p. 204, pl. 25, fig. 6, 1911; U. S. Geol. Survey Prof. Paper 84, p. 58, pl. 14, figs. 5, 6, 1914; U. S. Geol. Survey Prof. Paper 112, p. 129 (part), pl. 30, figs. 1, 2, 1919.

⁴¹ Velenovsky, Josef, Die Flora der böhmische Kreideformation, pt. 3, p. 11, pl. 4, figs. 5-7, 1884.

⁴² Knowlton, F. H., U. S. Geol. Survey Twenty-first Ann. Rept., pt. 7, 317, 1901.

Leaves small, thick, and entire, with stout petioles and midribs and obscure secondary venation which is immersed in the thick lamina. Length 2.5 to 5 centimeters; width 0.9 to 1.3 centimeters. Venation, where visible, showing numerous parallel, camptodrome, relatively long and thin secondaries, which branch from the midrib at acute angles. Though the majority of these leaves are equally acuminate at both ends, there is considerable variation in this respect, and a well-marked tendency is shown in many specimens that are relatively broader, especially in the upper half, toward an obtusely rounded apex, the termination of the midrib showing as a small mucronate point. The base in these forms gradually narrows to the stout petiole. The variations in outline of this species are well shown in the figures reproduced in Newberry's monograph.

Typical leaves of this species are not uncommon at Arthurs Bluff, Tex. It was described originally from specimens found in the upper part of the Raritan formation of New Jersey and has subsequently been recognized in the Magothy, Black Creek, and Tuscaloosa formations of the southeastern Atlantic Coastal Plain and in the Bingen sand of Arkansas. Somewhat similar obovate leaves of very coriaceous texture, formerly confused with this species, are somewhat younger and have recently been transferred by me to the genus *Euphorbiophyllum*.

It may well be questioned whether this and the following species of *Andromeda* should be referred to the Ericales. Certainly the present form has numerous points of contact with the leaves of *Eugenia*, which has been positively recognized in the lower Eocene floras of this general region.

***Andromeda snowii* Lesquereux.**

Andromeda snowii Lesquereux, U. S. Geol. Survey Mon. 17, p. 117, pl. 17, fig. 16, 1891 [1892].
Berry, Torrey Bot. Club Bull., vol. 39, p. 405, 1912.

Leaves small, entire, coriaceous, lanceolate, broadest in the middle and equally acute at both ends. Length 4.5 centimeters; maximum width 1.5 centimeters. Midrib stout. Secondaries oblique, regularly spaced, subparallel, camptodrome.

This species, of doubtful distinctness from the preceding, was described originally from material collected in the Dakota sandstone of

Ellsworth County, Kans. It is represented by a single specimen from Arthurs Bluff, Tex. It resembles the lanceolate leaves of the preceding species but is broader, with less numerous and much less ascending secondaries.

Order EBENALES.

Family EBENACEAE.

Genus DIOSPYROS Linné.

***Diospyros primaeva* Heer.**

Plate XXXIX, figure 2.

- Diospyros primaeva* Heer, Phyllites crétacées du Nebraska, p. 19, pl. 1, figs. 6, 7, 1866; Flora fossilis arctica, vol. 6, Abt. 2, p. 80, pl. 18, fig. 11, 1882; vol. 7, p. 31, pl. 51, figs. 5a, b, c, 1883.
Englehardt, Naturwiss. Gesell. Isis in Dresden Abh. 7, Jahrg. 1891, p. 98, 1892.
Lesquereux, The flora of the Dakota group, p. 109, pl. 20, figs. 1-3, 1892.
Smith, On the geology of the Coastal Plain of Alabama, p. 348, 1894.
Newberry, The flora of the Amboy clays, p. 124, pl. 30, figs. 1-5, 1896.
Knowlton, U. S. Geol. Survey Twenty-first Ann. Rept., pt. 7, p. 317, pl. 39, fig. 3, 1901.
Berry, Torrey Bot. Club Bull., vol. 32, pl. 2, 1905; vol. 34, p. 204, 1907; vol. 38, p. 417, 1911; New Jersey Geol. Survey Bull. 3, p. 211, pl. 29, fig. 1, 1911.
Hollick, The Cretaceous flora of southern New York and New England, p. 103, pl. 42, figs. 2, 11, 1906.
Berry, Maryland Geol. Survey, Upper Cretaceous, p. 894, pl. 90, fig. 4, 1916; U. S. Geol. Survey Prof. Paper 84, p. 61, pl. 11, fig. 3; pl. 14, figs. 12, 13, 1914; Torrey Bot. Club Bull., vol. 43, p. 303, 1916; U. S. Geol. Survey Prof. Paper 112, p. 134, pl. 30, fig. 3, 1919.

* Leaves oblong-ovate, variable according to age, ranging from 3 to 15 centimeters in length by 1.3 to 5 centimeters in greatest width, which is in the middle part of the leaf. Apex acute or obtuse. Base cuneate. Margins entire. Petiole rather long and very stout. Midrib also stout. Secondaries branching from the midrib, generally at acute angles, subopposite to alternate, parallel, camptodrome. Tertiaries forming polygonal areoles, whose relative prominence is one of the features of this species.

This species, which is suggestive of the modern *Diospyros virginiana* Linné, was described by Heer from specimens collected in the Dakota sandstone of Nebraska over half a century ago. It has proved to be a form of very wide range, having been identified at both the Atane and Patoot horizons in Greenland,

from the Cenomanian of Niederschoena in Saxony, and from various localities within the Dakota sandstone; and with the exception of the fragments from Marthas Vineyard and Long Island, which are of questionable identity, it is common in the Raritan and Magothy formations, or their homotaxial equivalents, from New Jersey to Alabama.

Its most marked character is the prominence of its tertiary areolation. It is common at various localities in the lower part of the Tuscaloosa formation of western Alabama and continues upward into those beds in Hale County which have been placed in the basal portion of the Eutaw formation and into the Coffee sand member of that formation in Tennessee. It is undoubtedly present, but not common, in the collections from Arthurs Bluff, Tex.

Order RUBIALES.

Family CAPRIFOLIACEAE.

Genus VIBURNUM Linné.

Viburnum robustum Lesquereux.

Plate XXXIX, figure 4.

Viburnum robustum Lesquereux, U. S. Geol. Survey Mon. 17, p. 120, pl. 20, figs. 4-6, 1891 [1892].

Knowlton, U. S. Geol. Survey Twenty-first Ann. Rept, pt. 7, p. 317, 1901.

Berry, Torrey Bot. Club Bull., vol. 39, p. 405, 1912.

Leaves shortly and broadly ovate, generally widest below the middle, narrowing upward to the obtuse tip. Base cuneate, slightly decurrent to the thick petiole. Margins entire, often somewhat undulate. Texture coriaceous. Length 7 to 10 centimeters: maximum width 5 to 6 centimeters. Petiole long and stout, about 3 centimeters in length. Midrib stout. Secondaries stout, ascending, somewhat irregularly spaced, rather straight, camptodrome or brachydrome.

This species is represented by characteristic specimens from Arthurs Bluff, Tex. It was described originally from material collected in Ellsworth County, Kans., and is not known from other areas.

POSITION UNCERTAIN.

Genus TRICALYCITES Newberry.

Tricalycites papyraceus Hollick.

Plate XL, figure 9.

Tricalycites papyraceus Hollick, Torrey Bot. Club Bull., vol. 21, p. 63, pl. 180, fig. 8, 1894.

Newberry, U. S. Geol. Survey Mon. 26, p. 132, pl. 46, figs. 30-38, 1896.

Hollick, New York Acad. Sci. Annals, vol. 11, p. 423, pl. 37, figs. 1, 2, 1898; New York Bot. Garden Bull., vol. 2, p. 405, pl. 41, fig. 3, 1902; U. S. Geol. Survey Mon. 50, p. 109, pl. 5, figs. 8-12, 1906.

Berry, Torrey Bot. Club Bull., vol. 31, p. 81, pl. 1, fig. 4, 1904; vol. 39, p. 405, 1912; New Jersey Geol. Survey Ann. Rept. for 1905, p. 139, 1906; New Jersey Geol. Survey Bull. 3, p. 221, 1911; U. S. Geol. Survey Prof. Paper 112, p. 137, pl. 28, figs. 1-5, 1919.

This very characteristic tri-alate fossil is abundant in the middle and upper parts of the Raritan formation of New Jersey. It occurs sparingly in the overlying Magothy formation and is very common in the lower part of the Tuscaloosa formation in western Alabama. It is abundant at Arthurs Bluff, Tex., the present collection containing eight typical specimens, some of them complete. They are in exact agreement with the Tuscaloosa forms and demonstrate what is discussed at length in my account of the Tuscaloosa flora, that the approximately parallel longitudinal venation of the wings is really a more or less forked and anastomosing venation, thus allying these fossils in a remote way with such modern genera as *Vatica*, of the Dipterocarpaceae.

This form, despite its uncertain botanic affinity, is an important stratigraphic type, readily and surely recognized at all times. It characterizes the Tuscaloosa, Woodbine, Raritan, and Magothy formations but has never been discovered in the Dakota sandstone.

Genus CARPOLITHUS of authors.

Carpolithus sp. 1.

A coriaceous, ovate, concavo-convex scale or fruit of unknown botanic affinity, represented by a single specimen in the Woodbine sand at Arthurs Bluff, Tex. It is of no value, either geologic or botanic, but is entirely unlike previously described forms.

Carpolithus sp. 2.

Plate XL, figure 1.

A coriaceous valve of a capsule or pod, laterally compressed, oval, and acuminate at both ends. About 1.5 centimeters in length and 8 millimeters in maximum width, in the median region. Represented by a single specimen in the Woodbine sand at Arthurs Bluff, Tex., and of unknown botanic affinity. Suggestive of a valve of some coriaceous, single-seeded leguminous form.

Carpolithus sp. 3.

Plate XL, figures 2-4.

A rhomboidal or obovate object with a somewhat transversely wrinkled, broadly rounded apex and a cuneate base, marked below the transversely striated apical arc by ascending, closely spaced, acutely forking subparallel veins. Of unknown botanic affinity, probably bracteate in character. Represented by three specimens in the Woodbine sand at Arthurs Bluff, Tex.



FIGURE 11.—Cut in the Woodbine sand near Arthurs Bluff, Tex.

PLATES XXXVI—XL

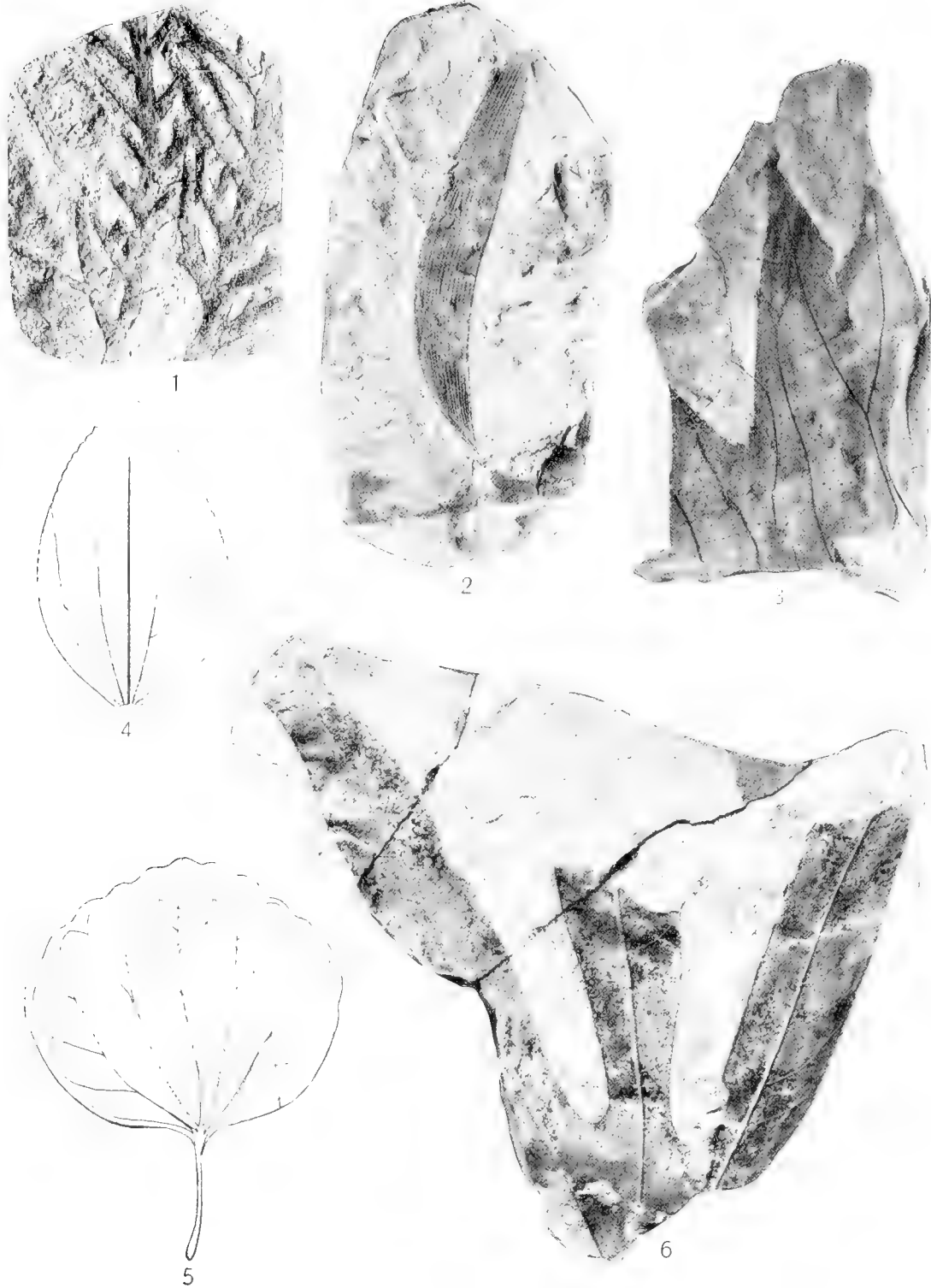

FOSSIL PLANTS FROM THE WOODBINE SAND.

1, *Brachyphyllum macrocarpum formosum* Berry; 2, *Podozamites lanceolatus* (Lindley and Hutton) F. Braun; 3, *Liriodendron quercifolium* Newberry; 4, *Zizyphus lamarensis* Berry; 5, *Trochodendroides rhomboideus* Berry; 6, *Sterculia lugubris* Lesquereux.

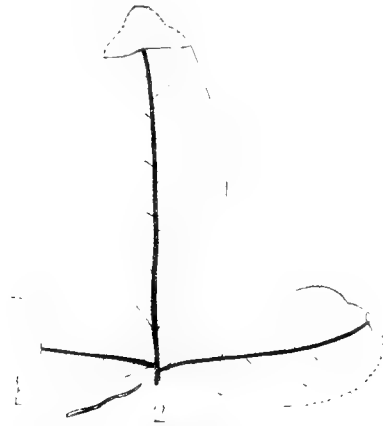
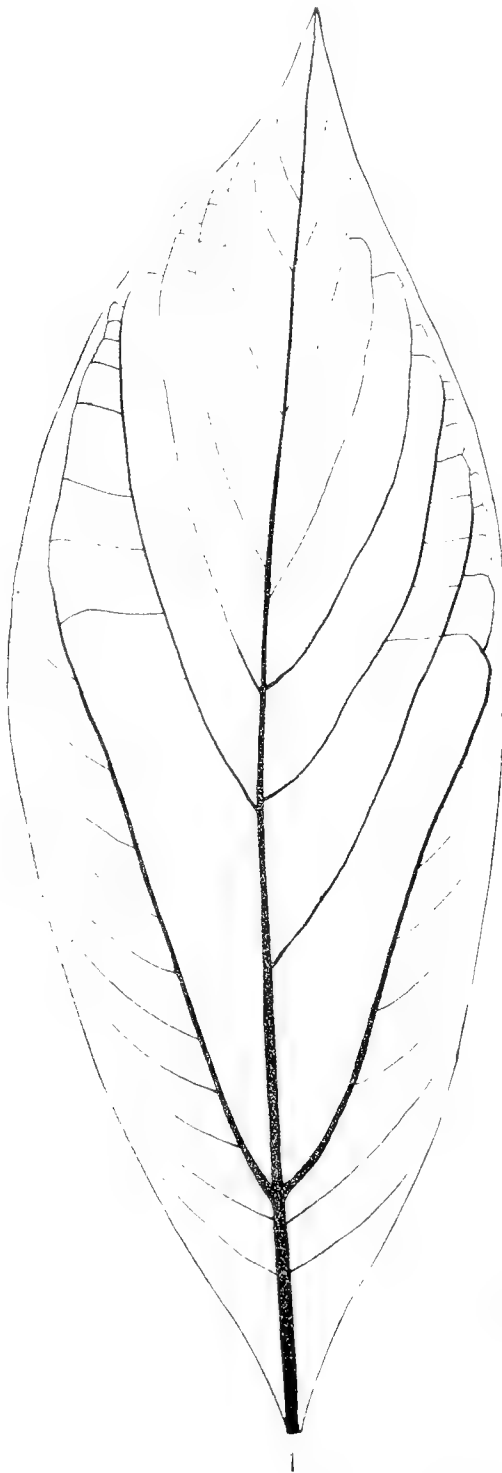

FOSSIL PLANTS FROM THE WOODBINE SAND.

1, *Oreodaphne alabamensis* Berry; 2, *Rhus redditifomis* Berry; 3, *Aralia wellingtoniana* Lesquereux.

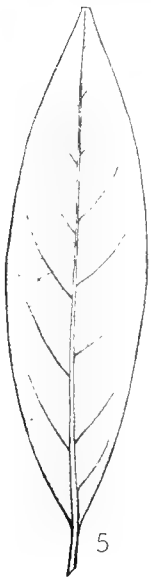

FOSSIL PLANTS FROM THE WOODBINE SAND.

1, *Andromeda novaecaesareae* Hollick; 2, *Benzoin venustum* (Lesquereux) Knowlton; 3, 4, *Aralia wellingtoniana* Lesquereux;
5, *Laurus plutonia* Heer.

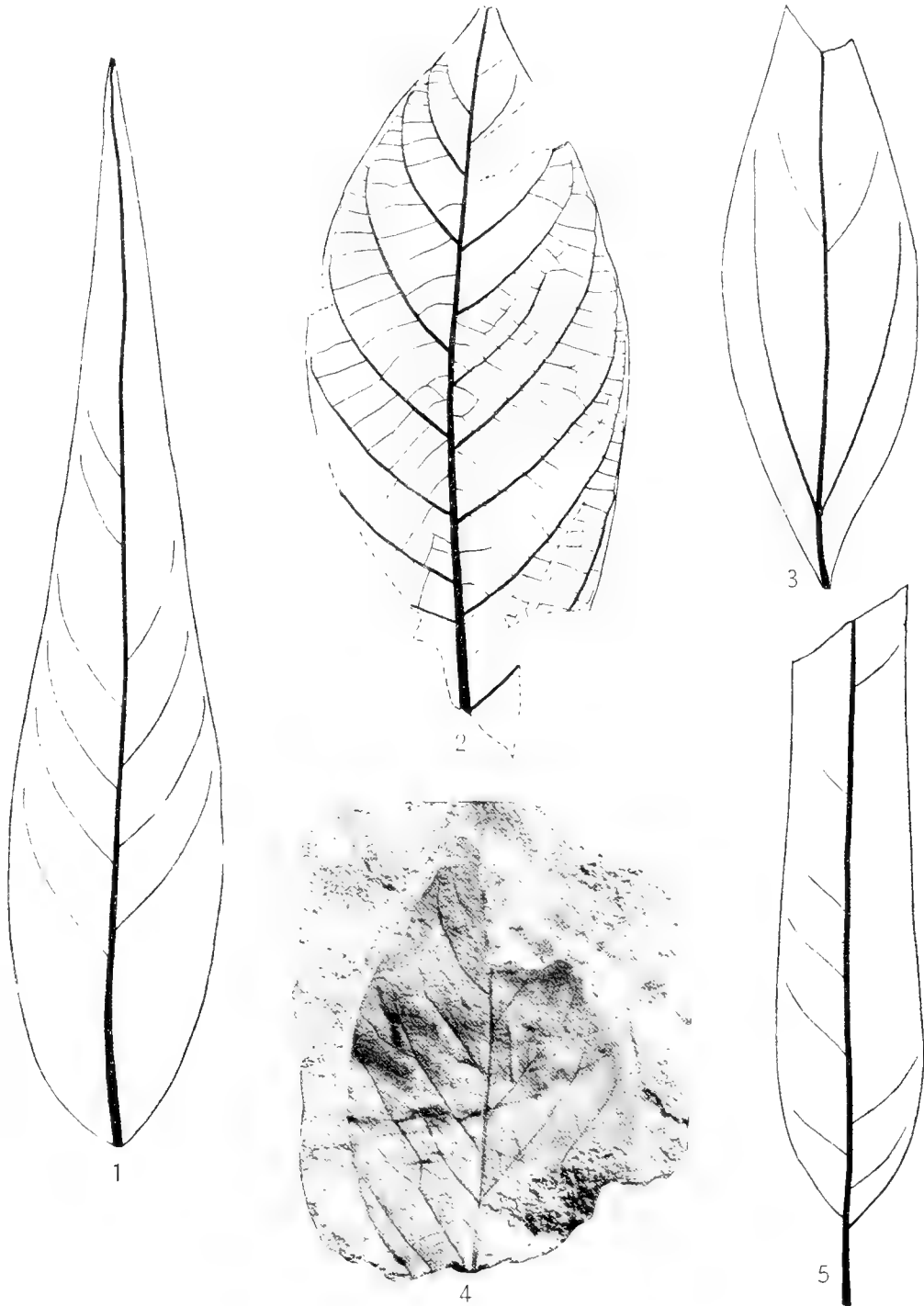

FOSSIL PLANTS FROM THE WOODBINE SAND.

1, *Ficus daphnogenoides* (Heer) Berry; 2, *Diospyros primaeva* Heer; 3, *Cinnamomum newberryi* Berry; 4, *Viburnum robustum* Lesquereux; 5, *Myrica longa* (Heer) Heer.



1

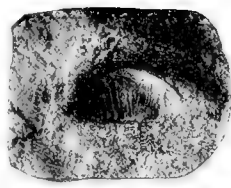

2

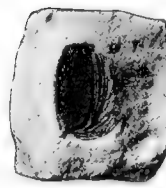

3



4



5



6



7



8

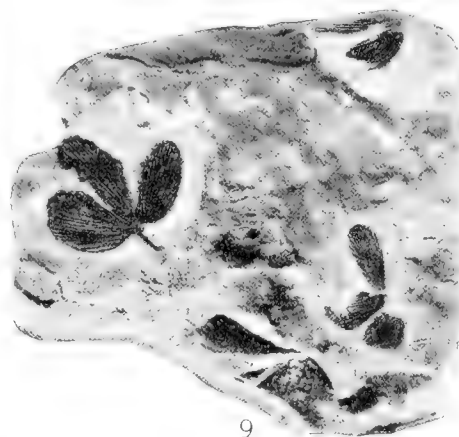

9

FOSSIL PLANTS FROM THE WOODBINE SAND.

1, *Carpolithus* sp. 2; 2, 3, 4, *Carpolithus* sp. 3; 5, *Cissites formosus* Heer; 6, *Magnolia speciosa* Heer; 7, *Rhamnus tenax* Lesquereux; 8, *Palaeocassia laurinea* Lesquereux; 9, *Tricalycites papyraceus* Newberry.

GEOLOGY OF THE LOWER GILA REGION, ARIZONA:

By CLYDE P. ROSS.

INTRODUCTION.

In 1917 and the early part of 1918 the writer made an investigation of desert watering places and routes of travel in a part of southwestern Arizona. The results of this work are to be published in two water-supply papers of the United States Geological Survey—a preliminary report giving information in regard to roads and watering places and a final report which is to include also much miscellaneous information on the geology, geography, and hydrology of the region. In the present report the geologic information obtained in the course of the work is summarized. As the geologic investigation was necessarily of a reconnaissance character, the information obtained is incomplete, but much of it is new and it is hoped will prove of value.

The area covered lies in the central part of Yuma County and the western part of Maricopa County, Ariz. In Maricopa County it includes an irregularly triangular region with Phoenix at its eastern vertex, bounded on the north and northeast by the road from Phoenix through Wickenburg to Wenden and on the south by the valleys of Salt and Gila rivers and extending westward to the county boundary. In Yuma County the area is bounded on the north by the road between Wenden and Parker through Cunningham Pass and on the south by the valley of Gila River and extends entirely across the county to the western boundary, Colorado River.

The commercial development of such a region as the one here described is intimately related to the geology. The hope of finding mineral deposits usually furnishes one of the initial incentives for pioneering in such regions. When promising deposits are found, as they have been here, towns spring into existence and the settlement of the country commences.

In the early days in southwestern Arizona fur trapping vied with prospecting as an occupation for the adventurous frontiersmen. When the country became a little better known and more settled, cattle raising and farming were introduced. Both of these industries, particularly farming, depend for their success on a supply of water. The available surface water here soon proved insufficient, and the settlers began to utilize the ground water by means of wells. The distribution, quantity, and quality of the ground water in a region are directly dependent on the geology and physiography of the region.

ROCK FORMATIONS.

At first glance most of the mountains in this section of the country present a very similar appearance. Examination soon shows, however, that they are composed of rocks of a number of very diverse types. There are great masses of ancient metamorphic rocks, of granites and granitic gneisses, and of lavas and tuffs belonging to at least two distinct periods, together with subordinate amounts of sediments associated with the older lavas and tuffs, and sand and gravel filling the valleys between the ranges. More detailed work will undoubtedly result in still further subdivision of the rocks. The metamorphic rocks certainly represent two and probably more than two periods. The granitic rocks belong to at least two periods of intrusion.

BASAL COMPLEX.

Definition.—Highly metamorphosed sedimentary rocks with associated granitoid gneisses and other rocks of igneous origin make up the whole or a large part of many of the mountain ranges in this region. These rocks will be referred to collectively as the basal complex. They may be divided into

four general groups—(1) igneous rocks, (2) highly metamorphosed schistose rocks, probably in the main of sedimentary origin, (3) thoroughly metamorphosed but much less schistose sedimentary rocks separated from those of the second group by an unconformity, and (4) metamorphosed but not schistose limestone and quartzite, the youngest sedimentary rocks in the basal complex. The igneous rocks may be further subdivided into batholithic masses with associated dikes and a group of somewhat younger dikes which cut the less metamorphosed portions of the basal complex.

Distribution and character.—This ancient complex is present in every mountain range and almost every range of hills in the region under consideration. Even in those mountainous areas where it is not shown on the geologic map (Pl. XLV, in pocket) outcrops can be found in stream beds that have been cut through the younger formations which elsewhere cover it. In some of the hills, especially those which are composed of basaltic lavas, such as the Bouse Hills and Palo Verde Hills, metamorphic rocks do not occur.

Many of the exposures of the basal complex consist of granitoid rocks. The bulk of these rocks are gray and pinkish gneisses which before their metamorphism were normal granites and intrusive rocks of similar types. These rocks are older than nearly all the other formations in the region, and they crop out in most of the mountain ranges. Plate XLI, *B*, shows their typical appearance. There are also in the region certain younger granites, not gneissoid, which Bancroft¹ considers to be Mesozoic. These are very similar in superficial appearance to the ancient granites in the several areas of such rocks mapped by previous workers. (See geologic map, Pl. XLV.) In the Buckskin Mountains near Osborne's Well there are outcrops of a fresh gray granite with no suggestion of gneissic structure. This rock contains specularite in places and perhaps has been otherwise mineralized, as several shallow prospect holes have been sunk in it. Probably it belongs to the group of Mesozoic intrusive rocks. The

¹ Bancroft, Howland, A reconnaissance of the ore deposits in northern Yuma County, Ariz.: U. S. Geol. Survey Bull. 451, p. 29, 1911.

boundaries of this mass were not mapped. Jones² reports the presence of Mesozoic intrusive rocks near Kofa, in the S. H. Mountains and in the Dome Rock Mountains. Bancroft³ found dikes probably of Mesozoic age in the Harecuvar Mountains and Granite Wash Hills. It is probable that there are other areas of igneous rock of this age in the region.

The basal complex also includes small dikes composed for the most part of diabase and pegmatite. They are of general occurrence but have nowhere been found in large quantity. Bancroft⁴ describes these rocks and also mentions certain exposures in the region north of that covered by the present report which he considers to be metamorphosed lava flows genetically related to the diabasic intrusive rocks.

In the Buckskin Mountains between Butler Well and Midway there are some good exposures of the ancient rocks. At one place in particular the unconformity between the major series of metamorphosed sediments, described below, and the gneiss can be clearly seen. Associated with the gneiss and clearly below the surface of unconformity are intensely metamorphosed schists, mostly somewhat chloritic. In the Gila Bend Mountains also there are small masses of fine-grained mica schists and quartzose schists included in the gneiss. At the southern extremity of the Big Horn Mountains, just north of the Palo Verde mine, is a hill composed entirely of dark-green foliated chloritic schist. (See Pl. XLI, *A*.) This rock is different from any observed elsewhere in the area, but presumably it is related in age to the rest of the metamorphic rocks. As it is very highly schistose, it is probably related to the most ancient of the schistose rocks. Blanchard⁵ reports inclusions of metamorphosed limestone and dolomite in a few places in the gneiss of the Buckskin Mountains. In one outcrop of dolomite he found what he considers may be indistinct traces of organic remains.

² Jones, E. L., Jr., A reconnaissance in the Kofa Mountains, Ariz.: U. S. Geol. Survey Bull. 620, pp. 151-164, 1916; Gold deposits near Quartzsite, Ariz.: *Idem*, p. 47.

³ Bancroft, Howland, *op. cit.*, p. 30.

⁴ *Idem*, p. 28.

⁵ Blanchard, R. C., The geology of the western Buckskin Mountains, Yuma County, Ariz.: Columbia Univ. Contr. Geol. Dept., vol. 26, No. 1, pp. 33-34, 1913.



A. HILLS OF CHLORITIC SCHIST AT THE NORTH END OF THE BIG HORN MOUNTAINS,
NEAR THE PALO VERDE MINE, MARICOPA COUNTY, ARIZ.



B. GONZALES WELLS, DOME ROCK MOUNTAINS, YUMA COUNTY, ARIZ.
The mountains in the background show the typical appearance of rocks of the basal complex.



A. A PLUG OF LATITE OF TERTIARY AGE IN THE DOME ROCK MOUNTAINS, ABOUT 4 MILES
SOUTHWEST OF QUARTZSITE, YUMA COUNTY, ARIZ.



B. BLACK BUTTE, CACTUS PLAIN, NEAR OSBORNE'S WELL, YUMA COUNTY, ARIZ.
An irregular intrusion of gabbro into Tertiary rocks.

The best exposures noted of the second type of metamorphic rocks of sedimentary origin are those in the Harcuvar, Harquahala, and Little Harquahala mountains, but they also occur in some of the other ranges. Interbedded limestones and quartzites are common, and the contrast in hardness between the rocks of these two types makes the bedding visible at considerable distances. The angles of dip in nearly all exposures noted are very moderate, and in most places the beds are nearly flat. Some of the lower beds in this series appear to be similar in composition to the underlying gneissic granite. They are doubtless metamorphosed arkosic sandstones derived from the ancient granitic rock. All the rocks of this series are notably metamorphosed, but many of them are not markedly schistose. Bancroft states that some of the calcareous rocks are dolomites. It is quite possible that more detailed work will result in further subdivision of this series. No attempt has been made to measure the thickness, but it is certainly considerably over 500 feet.

These rocks rest unconformably on the granitic gneisses which are so widespread in this region. The best exposure of the unconformity found is in the Buckskin Mountains on the road between Midway and Butler Well. At this locality gray granitic gneiss, inclosing masses of sericitic and chloritic schist, crops out. The schistosity strikes N. 30° W. and dips steeply to the southwest. These rocks are overlain by a mass of distinctly bedded but metamorphosed quartzite and sandstone, with some fine-grained crystalline limestone. The sandstone, especially near the base, is composed of débris from the gneiss below. Schistosity has been developed, especially in the sandstone, but it is not nearly so pronounced as it is in the lower rocks. The parting planes are parallel to the bedding. The beds have been crumpled, but not greatly. The maximum dip observed is 15°, and most of the beds are nearly flat. The average strike is N. 55° W., and the general dip is southwesterly. The section of the mass here exposed is over 150 feet thick. The contact between it and the gneiss and schist is somewhat irregular and is evidently an erosional contact. Both the older and the younger rocks are cut by small dikes of metamorphosed trap and by a dike composed entirely of microcline.

The known occurrences of the least metamorphosed sediments of the basal complex comprise those at the Socorro mine, in the Harquahala Mountains, and those in the northern portion of the Plomosa Mountains. Bancroft⁶ has studied the section at the Socorro mine and gives the following description of it:

Coarse-grained granite which shows some schistosity is the basal rock in this locality and is similar to the pre-Cambrian granite so universally present in this area. Resting unconformably upon the granitic rock is a series of slightly metamorphosed sediments, of which about 150 feet of fine-grained grayish-red quartzite forms the base. This is overlain by several hundred feet of yellowish-brown limestone, the upper portion of which contains intercalated argillites and quartz-mica schists. Strata of schistose shaly limestone and a rock very closely resembling a dolomite (containing, however, fragments of quartz) were noticed near the contact of the quartzite and the overlying limestone.

In the Plomosa Mountains, near the Little Butte mine, there are limestones similar to those at the Socorro mine, but their relations to the underlying rocks were not determined. At no place were any of these comparatively slightly metamorphosed sedimentary rocks observed in contact with any of the highly metamorphosed sedimentary rocks in the region, and the relations between them were therefore not determined. The lithologic character of the least metamorphosed rocks is similar to that of some of the Paleozoic sedimentary rocks at Globe, Ariz. For this reason and because of their relation to rocks that are almost certainly pre-Cambrian and their comparatively small metamorphism, it seems probable that they are of Paleozoic age. The lack of fossils renders positive correlation impossible.

There can be little doubt that the granitic gneisses and associated metamorphosed sedimentary rocks just described, with the possible exception of the youngest of the sedimentary rocks, are of pre-Cambrian age. The fact that no fossils which can be used to determine the age of the beds have yet been found in any of the rocks examined during the present investigation makes all the determinations of the age of formation somewhat uncertain. However, it can not be questioned that these metamorphic rocks are very old. Some of them might conceivably be Paleozoic, but the

⁶Bancroft, Howland, *op. cit.*, pp. 111-112.

absence of fossils is a strong argument against this possibility, for most of the Paleozoic rocks of the region are fossiliferous. The fact that all these rocks except the youngest group are very much more metamorphosed than the known Paleozoic formations to the north and east is another strong reason for believing that they are pre-Cambrian rather than Paleozoic. There is no reason for believing that there has been more metamorphism in this area since Paleozoic time than has occurred in the Ray and Globe mining districts. The limestone and quartzite of the youngest group are not much if any more metamorphosed than similar rocks of Paleozoic age at Ray and Globe.

TERTIARY FORMATIONS.

GENERAL FEATURES.

Lavas occur throughout the area covered by this report and extend far beyond its limits. The series consists of a number of flows of varying thickness and of widely different superficial characteristics, associated with some tuffs and agglomerates and a very subordinate amount of sedimentary rock. It reaches its maximum development in the S. H. Mountains, where the total thickness is certainly more than 2,000 feet. A number of the individual flows are several hundred feet thick.

Volcanic rocks similar in occurrence and general characteristics to rocks of this series have been reported from a number of localities in the Southwest. Such rocks are known in the Patagonia district, in southern Arizona;⁷ in Mohave County, Ariz.,⁸ to the north of the region covered by this report; in the Papago country,⁹ just south of this region; in eastern California,¹⁰ and in southern Nevada.¹¹ Similar rocks occur at Globe, in central Arizona,¹² and at many other places. These rocks have all been referred to the Tertiary, and most of

⁷ Schrader, F. C., Mineral deposits of the Santa Rita and Patagonia mountains, Ariz.: U. S. Geol. Survey Bull. 582, pp. 70-76, 1915.

⁸ Schrader, F. C., Mineral deposits of the Cerbat Range, Black Mountains, and Grand Wash Cliffs, Mohave County, Ariz.: U. S. Geol. Survey Bull. 340, pp. 57-59, 1907.

⁹ Bryan, Kirk, The Papago country, Ariz.: U. S. Geol. Survey Water-Supply Paper — (in preparation).

¹⁰ Brown, J. S., The Salton Sea region, Calif.: U. S. Geol. Survey Water-Supply Paper — (in preparation). Thompson, D. G., The Mohave Desert region, Calif.: U. S. Geol. Survey Water-Supply Paper — (in preparation).

¹¹ Ball, S. H., A geologic reconnaissance in southwestern Nevada and eastern California: U. S. Geol. Survey Bull. 308, pp. 31-34, 1907.

¹² Ransome, F. L., Geology of the Globe copper district, Ariz.: U. S. Geol. Survey Prof. Paper 12, pp. 88-95, 1903.

them are supposed to be Miocene. This supposition is based principally on their field relations to rocks of known age, the paleontologic evidence within the rocks themselves being scanty or lacking.

Overlying the Tertiary beds and associated with the unconsolidated or partly consolidated Quaternary sand and gravel are basalt flows of early Quaternary age. These will be discussed under the Quaternary formations. The faulted and uplifted basalts that cap many of the mountains, however, are considered to be of Tertiary age.

The amount of sedimentary material associated with the Tertiary lavas is small compared to the total thickness of the lavas. The sedimentary rocks are of geologic importance, however, for they furnish clues as to the conditions existing at the time these great flows occurred. They comprise sandstone, in part arkosic, shale, and calcareous beds.

TERTIARY LAVAS.

Distribution and character.—The Tertiary lavas are almost as universally present in this region as the metamorphic complex just described. They were found in almost every mountain range examined during this investigation, the only exceptions being the Harquahala and Little Harquahala mountains. Some of the ranges, such as the S. H., Eagle Tail, and Castle Dome mountains, are composed exclusively of rocks of this series resting on a metamorphic basement which is visible in only a few small areas.

The lavas are for the most part light-colored acidic rocks, but some are basalts. They display a wide range and variety of coloration. This is particularly striking in the Eagle Tail Mountains, where more than 1,000 feet of nearly horizontal lava flows, with interbedded tuff, is exposed. Nearly every flow is different in color from those above and below it, and each stands out from the others with clean-cut boundaries. Among the colors are brilliant yellow, soft green, vivid red, somber brown and dun, and creamy white, with streaks of purple, heliotrope, and other hues. The petrographer who is interested in Tertiary igneous rocks would find much to interest him here and in the other ranges in this region where similar rocks occur.

In most places the basalts appear to be the youngest of the flows, for they cap the others and form the summits of the mountains. Everywhere in the region the Tertiary basalts are subordinate in amount to the acidic flows. Thicknesses of 300 feet of basalt are rare, but 1,000 feet or more of acidic lava occurs at numerous places. The Tertiary basalts are best developed in the Gila Bend Mountains north of Point of Rocks.

Interbedded with the acidic flows are beds of siliceous agglomerate and rhyolitic tuff. The tuff is white or cream-colored, and the beds, which are in places scores of feet thick, are conspicuous. They have a wide distribution throughout the region.

The flows and tuffs are cut by pipes, dikes, and sills of felsitic igneous rock similar in general composition to the siliceous flows. The quantity of Tertiary intrusive rock exposed is very much less than that of the effusives. No large intrusive masses of this age are known anywhere in the region. A number of plugs or volcanic necks occur in the Plomosa, Dome Rock, and Eagle Tail mountains and some of the other ranges. A conspicuous plug in the Dome Rock Mountains is shown in Plate XLII, A. Court House Rock, a well-known landmark on the north side of the Eagle Tail Mountains, is a good example of such an intrusion. It is composed of cream-colored lava, in part weathered to a yellowish brown, and towers 1,000 feet sheer above its base, which is circular and only a few hundred feet in diameter. With the exception of a few cracks, mostly vertical, the walls are smooth and almost vertical nearly to the summit, where the cylindrical column has been partly broken by weathering. This peak is reported to have been scaled, truly a notable feat of mountain climbing. The range itself takes its name from a similar but even higher peak near its east end, whose summit is broken up into three points, showing a fancied resemblance to an eagle's tail sticking straight up into the air.

About 6 miles west of Osborne's Well, on the north side of one of the outlying hills of the Buckskin Mountains, is a scarp in which a peculiar exposure of igneous rock can be plainly seen. It is shown in Plate XLII, B. This is an intrusion of Tertiary age which differs in several respects from any seen elsewhere in the region. Microscopic examination shows

that the rock is a gabbro of coarse granulitic texture. The igneous mass has a very irregular outline, and the greatest extension exposed is in a horizontal direction. On the west are beds of brown sandstone dipping about 10° S. and striking roughly east. The contact with the gabbro is very irregular, and the sedimentary rocks are somewhat baked along it. Directly overlying the igneous rock is a basalt flow which caps the hill and is only 50 feet or so thick. When seen from a distance the lower part of the igneous mass seems to have a rough horizontal stratification, probably due to jointing. The upper part does not exhibit this apparent stratification but weathers in rounded masses 2 or 3 feet or more in diameter. The rock in these masses is full of grains of calcite, which give it a pseudoamygdaloidal appearance. The texture differs somewhat from that of the underlying portion, being on the whole coarser.

This irregular mass of gabbro was clearly intruded into the brown sandstone, which is almost certainly of Tertiary age. The basalt above is probably also Tertiary. There is no evidence to suggest that any other rock covered the basalt at the time the gabbro was intruded below it, but it is somewhat difficult to understand how a rock so coarsely crystalline as the gabbro could be intruded within 50 feet of the surface.

It should be noted that Bancroft¹³ considered all the basalt in this part of Arizona to be Quaternary. Basalts occur on the summits of a number of mountains in the area. The amount of erosion since they were poured out is measured in thousands of feet, so that if these basalts are Pleistocene, some of the most imposing mountain ranges in the area have been produced in large part at least during later Pleistocene or Recent time. At Point of Rocks, on Gila River in the western part of Maricopa County, basalt flows capping unconsolidated gravel of the valley abut against the eroded edges of lava mountains. Hence, the basalt flows that cap these mountains must be older than the lava in the valley. As the latter caps unconsolidated gravel it is clearly Quaternary, and it is so greatly dissected by erosion and so much weathered that it is clearly early Pleistocene. From these facts it is evident that the older basalt capping the mountains belongs to the Tertiary. In many

¹³ Bancroft, Howland, *op. cit.*, pp. 32-33.

places, however, it is very difficult or impossible to determine the age of a particular flow.

Petrography.—Petrographic examination shows that there is considerable similarity in type in these lavas throughout the area. Most of the flows and most of the intrusive rocks that cut them and are associated with them are latites and quartz latites; some are soda rhyolites. The tuffs examined are rhyolitic. Associated with these siliceous and sodic rocks, especially in the upper part of the series, are flows and dikes of basalt.

The latites are fine-grained rocks, in places porphyritic and commonly showing flow structure and perlitic growths. They are composed essentially of alkali plagioclase and orthoclase, with hornblende, biotite, and quartz usually present in subordinate amounts. Apatite and epidote were also noted in some specimens.

Most of the specimens of basalt examined are of the usual types, composed essentially of calcic plagioclase, augite, and olivine, with subordinate amounts of magnetite. They are somewhat porphyritic, all the minerals mentioned above, except the magnetite, occurring to a greater or less extent as phenocrysts. The groundmass is a fine-grained mass of plagioclase laths, showing in places parallel arrangement due to flowage, with granular augite and magnetite. Much of the olivine is altered to iddingsite.

Two specimens of basalt from the immediate vicinity of Woolsey Tank, in the Gila Bend Mountains, differ from those above described in that the feldspars are much more sodic. Their composition approaches that of oligoclase or albite-oligoclase. Stratigraphically these flows certainly are near the top of the series of Tertiary lavas, and they may even be of Pleistocene age. In the Buckskin Mountains near Osborne's Well Blanchard¹¹ found a rock which appears to be of a similar type.

TERTIARY SEDIMENTARY FORMATIONS.

Distribution and character.—Limestone and calcareous conglomerate occur in at least three widely separated localities in this area. Further work would probably disclose many other outcrops. The known localities are Osborne Wash, in the vicinity of Osborne's Well, near Parker; Saddle Mountain; and the Clanton

Hills and the valley north of them. Sandstone was found in Antelope Hill, in several places in the Gila Bend Mountains, near Osborne's Well, in the Clanton Hills, and in small amounts elsewhere. Shale is associated with some of the sandstone in the Gila Bend Mountains.

Antelope Hill, at the south end of the concrete bridge across Gila River near Wellton, is composed of grayish arkose, a sandstone formed from granitic debris. The rock is, as a whole, somewhat coarser grained near the base of the hill than farther up the slope. The average diameter of the grains ranges from 1 to 6 millimeters. The beds have a very gentle southerly dip. The hill is about 580 feet high, so that fully 500 feet of sandstone is exposed. Related but coarser sandstone and conglomerate occur farther south.¹⁵

Red sandstone crops out in several places in the Gila Bend Mountains, notably at and near Woolsey Tank, where there is a bed 30 feet thick of sandstone interbedded with the limestone. Near the Dixie mine, in the Gila Bend Mountains, red and purplish shale is associated with the sandstone. Plate XLIV, A (p. 191), shows Tertiary sandstone in these mountains overlain by Pleistocene gravels.

The relations of these sedimentary rocks to the Tertiary lavas show clearly that they are of similar age. They have been disturbed, like the lavas, by post-Tertiary faulting, so that the beds now dip in various directions. The Clanton Hills, about 25 miles north of Palomas, consist almost exclusively of flat-lying gray cherty fine-grained limestone with numerous concretions, some of which resemble fossils in superficial appearance. Some of the beds contain small and indistinct fossils. (See pp. 189-190.) At the west end of the hills is exposed a bed of reddish sandstone composed of quartz grains in a calcareous cement, about 30 feet thick. There has been some faulting accompanied by considerable brecciation in the limestone. Subsequent to the faulting hot solutions circulated through the fault breccias, as is shown by iron stains and by marked silicification of the limestone fragments. No definite evidence of valuable mineralization was found.

¹¹ Blanchard, R. C., op. cit., pp. 26-27

¹⁵ Bryan, Kirk, The Papago country, Ariz.: U. S. Geol. Survey Water-Supply Paper — (in preparation).

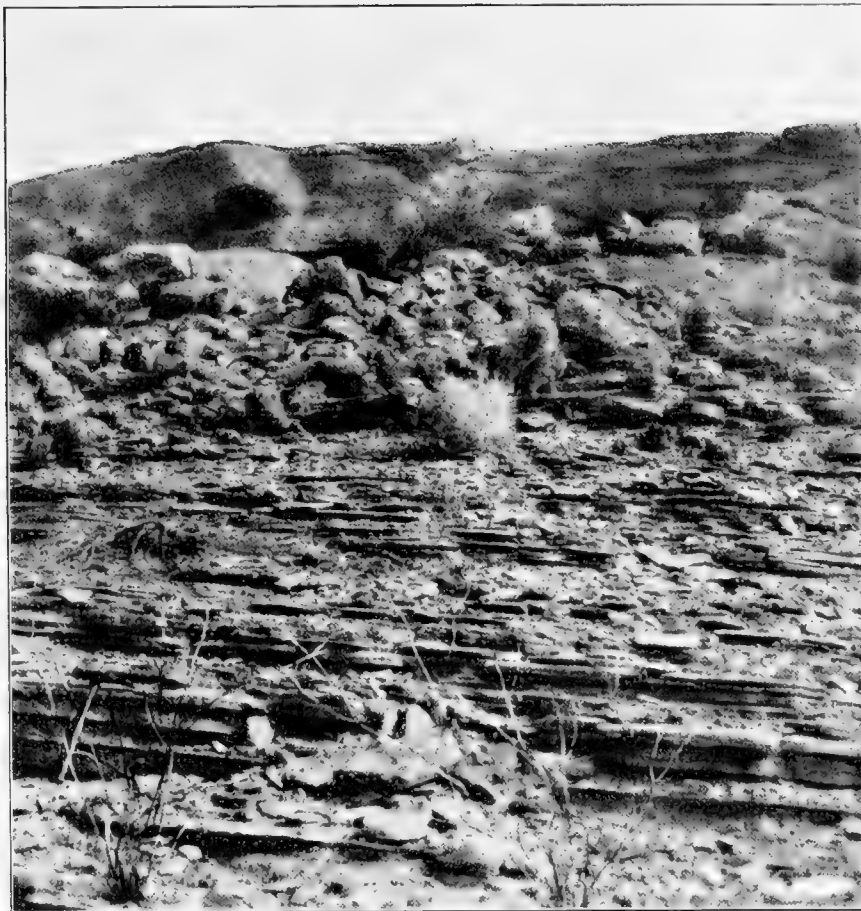

A. OSBORNE WASH, ABOUT 2 MILES SOUTHWEST OF OSBORNE'S WELL, YUMA COUNTY, ARIZ.
A typical exposure of Tertiary limestone overlain by basalt.



B. SADDLE MOUNTAIN, MARICOPA COUNTY, ARIZ., LOOKING SOUTH.
Showing pockets or caves in Tertiary calcareous agglomerate or conglomerate



1. BANK OF WASH NEAR WOOLSEY TANK, GILA BEND MOUNTAINS, MARICOPA COUNTY, ARIZ.
An exposure of tilted Tertiary sandstone unconformably overlain by tilted Quaternary gravel.



2. WOOLSEY TANK, GILA BEND MOUNTAINS, MARICOPA COUNTY, ARIZ.
Coarse gravel with calcareous cement, of Quaternary age, resting on the surface of Tertiary basalt.

Near Osborne's Well there are considerable exposures of sedimentary rocks. Time did not permit a detailed examination of them, but the scattered observations made may be of interest. To the west and south of the well are hills with cliffs cut by the large wash that passes between them. These cliffs expose conglomerate with a calcareous matrix, capped by a basalt flow. The calcareous rock is well bedded. The pebbles in it are in no place very abundant and in the lower portion are lacking altogether. Farther north up this wash are outcrops of red sandstone with concretions, a minor amount of quartz sandstone, and a few small beds of conglomerate. These rocks rest unconformably on gray granitic gneiss. The gneiss, which is very probably pre-Cambrian, is intruded by a light-colored granite, which looks very fresh and is not in the least gneissic in texture. This granite contains a little specularite and is apparently associated with certain small veins that contain quartz, specularite, and small amounts of sulphides and have been prospected to some extent in this vicinity. The granite, in common with similar rocks in the region associated with mineral veins, is probably Mesozoic. The sandstone rests unconformably on this granite, as well as on the older gneiss. A distinct though narrow bed of basal conglomerate containing granite pebbles occurs between the granite and the sandstone. A short distance farther north red vesicular basaltic or andesitic lava is interbedded with the red sandstone.

Exposures of sedimentary rocks are found for about 8 miles west of Osborne's Well along the road to Parker. There are numerous outcrops of thin-bedded limestone similar in appearance to the matrix of the conglomerate at the well, but entirely free from any but very small pebbles. Several of these outcrops are capped with vesicular olivine basalt. (See Pl. XLIII, A.) They contain rather numerous small and poorly preserved fossils (see next section) and a few small angular fragments of quartz and feldspar. Blanchard¹⁶ considers these calcareous beds to be tuffaceous and states that the beds underlying the basalt at Osborne's Well have a groundmass of glass.

Interbedded with the lavas of Saddle Mountain, in Maricopa County, are considerable thicknesses of fragmental rocks ranging from

agglomerate and breccia of distinctly igneous character to rocks that have angular fragments of lava about an inch in diameter in a white calcareous matrix. In certain cliffs there are peculiar hollows in beds of conglomerate and agglomerate, some of which almost amount to caves. (See Pl. XLIII, B.) The hollows appear to be due to a sort of concave exfoliation. They are not the result of solution or erosion.

Fossils.—The only fossils collected during this investigation were found in the limestone at two localities—in Osborne Wash near Osborne's Well and in the Clanton Hills. In Saddle Mountain there are beds of calcareous conglomerate which are lithologically very similar to those near Osborne's Well, but no specimens were collected from this locality, and it is therefore impossible to say whether these beds contain any small organic remains such as were found in the limestone near the well. The conglomerate of Saddle Mountain contains small bodies which are, superficially at least, similar to those in the limestone from the two localities mentioned, which W. H. Dall, of the United States Geological Survey, calls "pseudomorphs of what were probably a smooth cypridian crustacean."

Specimens from Osborne Wash and from the Clanton Hills were submitted to Mr. Dall for identification of the fossils. A specimen collected by John S. Brown, of the United States Geological Survey, from Imperial County, Calif., was submitted at the same time. This specimen, which closely resembles the specimen obtained near Osborne's Well, came from ledge in the west bank of an arroyo at the south entrance to a pass through the Palo Verde Mountains on the road from Glamis to Palo Verde, in either sec. 18 or 19, T. 10 S., R. 27 E., San Bernardino base line and meridian. Mr. Dall states that the specimen obtained near Osborne's Well and the one obtained by Mr. Brown in California "contain the same fossils and were doubtless laid down under practically identical conditions, whether absolutely contemporaneous or not." He found in these two specimens

small oval bodies representing pseudomorphs of what were probably a smooth cypridian crustacean, * * * also imprints of fragments of a gastropod which resemble analogous fragments of *Melania*, or *Goniobasis*, and a small triangular bivalve which appears to be most like a minute

¹⁶ Blanchard, R. C., op. cit., pp. 24-26

Corbicula, and not (as one might expect) belonging to the more common group of *Sphaerium* or *Pisidium*. There is also the imprint of a small leaf resembling a willow, and numerous lime tubes which seem to have been formed around roots or small vegetable stems.

Microscopic examination of the specimen found near Osborne's Well shows that it is very porous and is composed almost exclusively of calcareous matter in fragments of diverse shapes, with a few angular fragments of quartz and feldspar. The lime tubes mentioned by Mr. Dall are prominent in the thin section.

In a specimen of thin-bedded limestone from the east end of the Clanton Hills Mr. Dall found pseudomorphs of cypridian crustaceans like those he found in the other specimens mentioned. In one of the calcareous beds in Osborne Wash Blanchard¹⁷ also found fossils, which Mr. Dall identified as the gastropod *Bittium* and a probable young *Corbicula*. He states: "There is nothing incompatible between the presence of *Bittium* with *Goniobasis* and *Corbicula* in the same deposit. All are prone to inhabit brackish water, especially near seashores." He also says: "There is no clue to the age of the deposit except that it is doubtless Tertiary."

QUATERNARY FORMATIONS.

SEDIMENTARY FORMATIONS.

Definition.—The unconsolidated and poorly consolidated gravel, sand, and silt that fill the valleys and floor the flood plains of the rivers in this desert region are of Quaternary age. Basalts which are clearly also Quaternary are interbedded with or rest upon these sediments.

Distribution and character.—The valleys throughout this area, like nearly all other desert valleys in the Southwest, are deeply filled with detrital material, for the most part unconsolidated or poorly consolidated, derived from the mountains. The thickness of this material in the valleys has not been determined. It is certainly to be measured in hundreds if not in thousands of feet, as is indicated by records of wells in a number of the valleys.

The character of the material varies greatly, as is to be expected in sediments laid down by generally short and usually disconnected streams under arid conditions. In the flood

plains of Gila and Colorado rivers and in certain clay flats, or playas, in interior valleys there are very fine silts or clays, but the major portion of the fill in the valleys is sand and gravel, in places very coarse. Much of it is poorly assorted, consisting of coarse sediments in a clayey matrix. The surface layers in most of the valleys contain silty soil more or less mixed with gravel. This soil, where it has been properly irrigated, has proved to be highly productive. In Castle Dome Plain, Palomas Plain, and to a less general extent in a number of the other valleys in the area the wind has removed the surface silt, leaving a residual floor of gravel. Sand dunes are common in Cactus Plain and also occur in Eagle Tail Valley.

In almost every place where the fill is indurated to any extent the cement is a calcareous material called "caliche" and known also as cement or hardpan. Lee¹⁸ has described the mode of occurrence of caliche and discussed the theories as to its origin. He concludes that the caliche in Salt River valley, which is essentially similar to that in the lower Gila region, has been formed in part by the deposition of carbonates and other salts held in solution in the ground water and in part by the evaporation of water percolating downward from the surface. On the old road across the Gila Bend Mountains, west of Woolsey Tank, occur gravel beds with a calcareous cement which has set so firmly as to form a hard though friable rock. (See Pl. XLIV, B.) These beds are exceptionally indurated, but caliche beds so hard that it is very difficult to penetrate them with pick and shovel are common in a number of places in the region. Such beds are known elsewhere in the Gila Bend Mountains, in Nottbusch Valley, in Castle Dome Plain, and in other localities. Wells sunk in La Posa Plain and McMullen Valley usually penetrate beds of caliche below unconsolidated gravel and sand. On the flanks of the Plomosa Mountains, on the east side of La Posa Plain, lie thick deposits of caliche-cemented gravel, some of which is auriferous.¹⁹ Similar deposits occur on the flanks of the Dome Rock Mountains west of this plain.

Beds of green and yellow banded clay are exposed in the terraces of Colorado River in the Colorado River Indian Reservation near Parker.

¹⁸ Lee, W. T., Underground waters of Salt River valley, Ariz.: U. S. Geol. Survey Water-Supply Paper 136, pp. 107-111, 1905.

¹⁹ Bancroft, Howland, op. cit., p. 88.

¹⁷ Blanchard, R. C., op. cit., p. 39.

Fossil fresh-water shells have been found in some of these beds. E. L. Jones, jr.,²⁰ who made an examination of the reservation for the United States Geological Survey in 1914, states that these are lake beds.

Along washes within the mountains and on the borders of the ranges are beds of gravel and sand similar to those of the valley fill. These beds are cut by the present washes. Although they are clearly similar to the material in the modern streamways and were deposited under conditions very similar to those existing to-day, the position of many of these beds indicates that they were laid down in streams whose courses had little or no relation to those of the present streams. The gravel and sand are everywhere somewhat consolidated. In the wash that parallels the new road where it emerges from the mountains on the west side the unconsolidated or slightly consolidated gravel of the valley fill can be seen lapping up on the gently inclined and smooth surface of gravel with a calcareous cement. This gravel is continuous with gravel of the type just described occurring in the mountains proper. Similar exposures were noted near the road between Wenden and Butler Well, on the north side of Cunningham Pass, in the Harcuvar Mountains. Gravel of similar appearance, which is being eroded by the present streams, was noted in Osborne Wash, north of Osborne's Well, in the Buckskin Mountains.

The partly consolidated detrital beds in the mountains are in places cut by normal faults and tilted to angles of 20° and even more. The best exposures found are in the Gila Bend Mountains. (See Pl. XLIV, A.) Tilted blocks of gravel were noted near both of the roads that cross this range, but they are especially well exposed along the part of the old road that lies in the mountains. Outcrops of such material were found also along the large wash followed by the old road on the west side of the mountains. Slight folding in gravel beds was observed in some outcrops near Woolsey Tanks, along this road. Tilted gravel and sand are exposed at the north end of the Gila Mountains near Dome. Some of the more consolidated alluvium in the Dome Rock and Buckskin mountains is probably tilted. Beds of gravel and sand that have

been disturbed by earth movements doubtless exist elsewhere in the region but were not noted during this investigation.

It is evident that Quaternary sediments belonging to at least three periods of deposition occur in this area. These are (1) the somewhat consolidated beds exposed in and near the mountains, which have been disturbed by faulting, (2) the unconsolidated or only locally consolidated flat-lying valley fill, and (3) the recently deposited material in the washes and the playas of the desert valleys and in the flood plains of the larger streams. This conclusion is in accord with the results of Lee's work²¹ in adjoining areas and in portions of the area here considered. He has given formational names to the two older Quaternary formations in the vicinity of Colorado River but not to the recent material flooring the river flood plains, etc. The oldest group of gravels and sands he calls the Temple Bar conglomerate. The unconsolidated material resting upon the Temple Bar conglomerate and exposed in terraced bluffs along Colorado River and elsewhere he calls the Chemehuevis gravel. The Temple Bar conglomerate is lithologically similar to the oldest of the three Quaternary formations herein described, but the thicknesses observed by Lee along the upper Colorado are far greater than any found in this region. The two may perhaps be of similar age and history. The Gila conglomerate, described by Gilbert,²² is similar to the Temple Bar, being a thick formation of coarse alluvium in the upper Gila Valley. The correlation of these formations awaits the complete solution of the physiographic history of southwestern Arizona in Quaternary time.

QUATERNARY BASALT.

Associated with the gravel and sand of the valley fill in places in this area are flows of olivine basalt. Such rock caps the fill, is interbedded with it, and cuts it in the form of dikes and other intrusive masses, generally small and irregular. The basalt masses that rise above the present surface of the fill have produced

²¹ Lee, W. T., Geologic reconnaissance of a part of western Arizona: U. S. Geol. Survey Bull. 352, pp. 17, 18, 1908; Underground waters of the Salt River valley, Ariz.: U. S. Geol. Survey Water-Supply Paper 136, pp. 111-114, 1905.

²² Gilbert, G. K., U. S. Geog. and Geol. Surveys W. 100th Mer. Rept., vol. 3, pp. 540-541, 1875.

²⁰ Personal communication.

land forms of two general types. These are flat mesas formed by flows that have spread out over the surface of the fill, as at Point of Rocks and Enterprise dam, both on Gila River, and groups of low, more or less conical hills, of which the Bouse Hills, near Bouse, Yuma County, and the Palo Verde Hills, northwest of Arlington, Maricopa County, may be mentioned as examples. The mesas consist of flows 100 feet thick or less, with a few thicker ones. The hills are in general not over 200 or 300 feet high, and many are less than this. The conical shape of many of them suggests that they are volcanic plugs, but all are dissected by erosion, and nowhere was a definite crater found. All the basalt masses, in both mesas and hills, are eroded and have a weathered appearance. The basalt in this area is not nearly as fresh in appearance as much of that in California.²³ The relation of the basalt to the valley fill proves it to be Quaternary, but it is probably not younger than early Pleistocene.

STRUCTURE.

Normal faults are the most pronounced structural features of the rocks of this region. Thrust faults are not known anywhere in it, and only minor folds appear to have been formed since pre-Cambrian time. There seem to have been three general periods of faulting—(1) prior to the eruption of the Tertiary lava, (2) subsequent to the eruption of the Tertiary lava, and (3) subsequent to the deposition of the older Quaternary alluvium. These periods of movement are not sharply separated from one another. Indeed, it is probable that movement along fault planes has been in progress almost continuously from the beginning of pre-Tertiary faulting to the present day. A few of the mountain ranges in the region show no evidence of being faulted, either because they had a different origin or because erosion has entirely removed the evidence.

FOLDS.

The small blocks of early pre-Cambrian sedimentary rocks included in the gneiss in several localities are notably schistose. As regional schistosity can not be produced with-

out folding, such deformation must have taken place early in pre-Cambrian time. The later pre-Cambrian rocks are in large part not schistose, and over large areas their strata are flat or dip at gentle angles. Certainly no close folding has taken place in these strata since their deposition. The tipping of the beds in some localities is the result of faulting. As the rocks show evidence of widespread dynamic metamorphism they must have been subjected to great pressures, which probably resulted in broad and gentle doming.

In the Eagle Tail Mountains and probably in some of the other ranges the beds of Tertiary lava are curved in a way to suggest gentle local folds. This apparent bending may be and in most places probably is a result of original deposition and not of subsequent folding. Certainly no large amount of folding has affected the Tertiary lavas.

In the Gila Bend Mountains some of the beds of the older Quaternary alluvium have been gently folded, but most of the Quaternary deposits are undisturbed by folding.

FAULTS OLDER THAN THE TERTIARY LAVA.

When Tertiary volcanism began the surface of the region was irregular. Some of the mountain ranges which are present to-day existed then, although they may not have been as high or as rugged as they now are. The Harquahala and Harecuvar mountains and the Granite Wash Hills contain no known areas of lava and probably never were capped by such material. They are the result of some cause which antedates the lava. No evidence of close folding can be found in these ranges. It is possible, even probable, that their uplift was caused by faulting. There are several other ranges in the region that probably belong in this class, but so little is known about them that this is not certain.

The bold, almost precipitous northwestern face of the Harquahala Mountains has an appearance that suggests a fault scarp modified by erosion. The abrupt truncation of almost flat beds of pre-Cambrian sedimentary rocks in the southwestern slopes of the Granite Wash Hills near Vicksburg and elsewhere is also suggestive of faulting. Southwest of these hills, only a mile or so from their bases, are small hills of basalt of Tertiary or Qua-

²³ Darton, N. H., and others, Guide-book of the western United States, Part C, The Santa Fe Route: U. S. Geol. Survey Bull. 613, pp. 158 et seq., 1915.

ternary age. The rock is more weathered than the basalts of known Quaternary age and is believed to be Tertiary. It was clearly erupted after the Granite Wash Hills came into existence.

Large portions of the Vulture Mountains, the White Tank Mountains in Maricopa County, the Palomas Mountains, the Maricopa Mountains, and other ranges lie above any known lava flows and probably never were covered by such flows. The character of the topography of areas of the basal complex from which the lavas have but recently been removed and the irregular lower contact of the lavas that are exposed in many places in the mountains show that the surface upon which they were poured out was hilly if not actually mountainous. This is especially well shown in the Gila Bend and Eagle Tail mountains.

In adjoining parts of Arizona there is conclusive evidence of pre-Tertiary faulting. Mountain building²⁴ attended by faulting took place during the Mesozoic era in what is now Cochise County. Bryan²⁵ has found evidence of a similar period of faulting in Pinal and Pima counties. Ransome²⁶ showed that faults of pre-Tertiary age probably exist in the Globe district, and this inference has been confirmed by later work in the Old Dominion mine.²⁷

FAULTS YOUNGER THAN THE TERTIARY LAVA.

There is abundant evidence, both within and near the region covered by this report, of normal faulting subsequent to the eruption of the Tertiary lavas. The lavas have been broken into numerous blocks that dip in various directions and are bounded by faults with various strikes. Almost every range containing Tertiary lavas has obvious examples of such fault blocks. In some localities, as at Saddle Mountain, there are more or less heterogeneous groups of fault blocks. In others the whole mass of lavas composing the

range has been lifted, relative to the blocks on either side, with but little change in the horizontal attitude of the beds. The Eagle Tail Mountains and probably also the S. H. Mountains are of this character. The structure in both ranges is complicated by cross faults which have broken portions of the large block into smaller tilted blocks. Probably the Plomosa, Big Horn, Castle Dome, and other ranges are built up, in part or wholly, of such horst-like blocks broken by cross faults and carved by erosion, but the blocks of lava are now comparatively small, and many of them are tilted, so that the evidence as to the character of the originally dominant structure is obscure. Probably the faults of this period followed in part the lines of weakness developed during the pre-Tertiary crustal movements, but it is also probable that faulting along entirely new planes took place. Most of the ranges either trend approximately N. 50° W. or N. 50° E. or show a combination of these two directions. The strike of the ranges near Colorado River is more nearly north than that of most of those farther east. This is true both of those that strike west of north and those that strike east of it. The trends of the ranges doubtless correspond to the strikes of the major faults in them. Minor cross faulting in other directions also took place.

QUATERNARY FAULTS.

Probably no formations of known Quaternary age in this region are involved in large-scale faults. Minor earth movements broke and tilted the partly consolidated strata of older Quaternary alluvium in the Gila Bend Mountains and elsewhere. Probably some movement took place along the fault planes formed during the previous period of crustal disturbance. Lee²⁸ found evidence of considerable Quaternary faulting at Mesa and Tempe. This movement lowered some of the valley fill in this vicinity below sea level, as is shown by the log of a deep well at Mesa. Ransome²⁹ and others have shown that the Gila conglomerate is faulted in many places in the mountains east of Phoenix.

²⁴ Schrader, F. C., Mineral deposits of the Santa Rita and Patagonia Mountains, Ariz.: U. S. Geol. Survey Bull. 582, p. 77, 1915.

²⁵ Bryan, Kirk, The Papago country, Ariz.: U. S. Geol. Survey Water-Supply Paper — (in preparation).

²⁶ Ransome, F. L., Geology of the Globe copper district, Ariz.: U. S. Geol. Survey Prof. Paper 12, p. 104, 1903.

²⁷ Borge, G. N., personal communication.

²⁸ Lee, W. T., Underground waters of Salt River valley, Ariz.: U. S. Geol. Survey Water-Supply Paper 136, p. 115, 1905.

²⁹ Ransome, F. L., op. cit., p. 104.

GEOLOGIC HISTORY.

EARLY PRE-CAMBRIAN TIME.

The remnants of the oldest pre-Cambrian rocks in this area are so few, so widely scattered, and so intensely metamorphosed that almost nothing can be learned from them as to the events of that ancient time. The rocks referred to are the micaceous and chloritic schists, quartzitic schists, and metamorphosed limestones included in gneiss in the Buckskin and Gila Bend mountains. (See p. 184.) Some of these rocks have the megascopic appearance of highly altered sediments, but it is by no means certain that that is their origin. The large amount of chlorite in some of the schists suggests an igneous origin, but nothing more definite is known regarding them. All that the record shows is that in early pre-Cambrian time certain rocks, principally of sedimentary but perhaps also in part of igneous origin, existed here. These rocks were buried, metamorphosed, and finally intruded by batholithic masses of granite and kindred rocks. The period of intrusion was followed by a very long period of erosion. Nearly all the ancient schists were removed, and the granitic rock was exposed. Meanwhile the granites had been rendered gneissoid, and the blocks of other rocks included in them had been highly altered by dynamic metamorphism.

LATE PRE-CAMBRIAN TIME.

The next event recorded was sinking of the land and influx of the sea. A thick series of sandstone and limestone with some shale was laid down in this sea.

Many dikes, principally of diabase and pegmatite, are associated with the metamorphic formations. Some of these are to be correlated in age with the ancient batholithic intrusions and are older than the younger pre-Cambrian sedimentary rocks. Others clearly cut and are therefore younger than the later sedimentary rocks. The field work was not sufficiently detailed to make it possible to differentiate these dike rocks. Bancroft has found evidence in the northern portion of the area indicating that volcanism occurred during the period of marine sedimentation. (See p. 184.)

PALEOZOIC AND MESOZOIC TIME.

No sediments of known Paleozoic or Mesozoic age have been found in the region. Limestones and quartzites of possible Paleozoic age occur in the Harquahala Mountains and elsewhere. (See p. 185.) These rocks represent either sedimentation near the end of pre-Cambrian time or a continuation of marine sedimentation in the Paleozoic, but the evidence at hand is not sufficient to determine their age definitely. If any other Paleozoic or Mesozoic sediments were ever deposited in this region they have since been almost or entirely removed by erosion. It is possible that small amounts of such rocks occur in those parts of the region that were not visited during this investigation. Enough is known, however, to justify the belief that no large areas of such rocks are present anywhere in the region covered by this report.

The region was again uplifted at some time after the period of marine conditions recorded by the pre-Cambrian sedimentary rocks. Erosion was resumed and was long continued. If the marine sediments covered the whole region at the end of pre-Cambrian time, they have been completely removed over large areas and the gneisses once more laid bare. There is abundant evidence, however, that the surface over which the Tertiary lavas flowed was by no means a plain. The country was rolling and hilly. Some of the small mountain ranges that are present to-day existed then, although it is probable that they were not as high or as rugged as they are now.

Granitic stocks or small batholiths accompanied or immediately followed by dikes of various types were intruded into the rocks of this region at some period after the pre-Cambrian and before the Tertiary. The writers who have previously described such rocks consider them to be Mesozoic. This correlation seems to be probable and entirely in accord with the facts so far as they are known. Rocks of this type have been reported from the Dome Rock Mountains,³⁰ the S. H. Mountains,³¹ and the Harecuvar Mountains³² and

³⁰ Jones, E. L., jr., Gold deposits near Quartzsite, Ariz.: U. S. Geol. Survey Bull. 620, p. 48, 1916.

³¹ Jones, E. L., jr., A reconnaissance in the Kofa Mountains, Ariz.: U. S. Geol. Survey Bull. 620, p. 153, 1916.

³² Bancroft, Howland, Reconnaissance of the ore deposits in northern Yuma County, Ariz.: U. S. Geol. Survey Bull. 451, pp. 29-30, 1911.

were noted during the present investigation in the Buckskin Mountains. A number of similar intrusions are known in adjoining regions.

The pre-Cambrian rocks were considerably metamorphosed during the period between their deposition and that of the Tertiary lavas. The metamorphism probably took place in pre-Cambrian time, for Paleozoic rocks in adjoining regions show no evidence of having been affected by it. There has been no close folding since the deposition of the later pre-Cambrian rocks. Thick masses of these rocks are now exposed which show no folding and little tilting. Faulting took place at some period prior to the eruption of the Tertiary lavas, and it is probable that during that period the major areas of uplift which form the present areas of these rocks may have been blocked out, at least in part.

TERTIARY TIME.

The Tertiary was a period of pronounced volcanism, in which great sheets of lava were piled up in flow upon flow. Agglomerate and tuff are associated with the lavas, but in very subordinate amount. Quiet outflows rather than eruptions of explosive violence were the rule. Bancroft³³ states that volcanic plugs are present in several places in the area in northern Yuma County which he examined and are apparently more numerous near the lower part of Williams River than elsewhere. These plugs may represent remnants of Tertiary volcanoes. Plugs of latitic rock occur near Saddle Mountain, west of Quartzsite, in the Dome Rock Mountains, and at a few other places in the region covered by this report, but such remnants of Tertiary volcanoes are rare. Quite possibly most of the eruptions were of the fissure type, and no volcanoes, except a few small ones, ever existed here. Probably lava flowed over much of this region during the Tertiary period, covering most of the hills then existing. Apparently, however, some ranges were never capped completely by the lava. The Harquahala, Little Harquahala, and Harcuvar Mountains belong to this class, and portions of the Buckskin Mountains and of some of the other ranges may also have escaped being covered. Felsitic Tertiary intrusive rocks and possibly some lavas occur

in the Dome Rock Mountains, but this range consists almost exclusively of rocks of the basal complex. If the range was ever lava capped, all the lava has since been removed by erosion. Comparatively little is known in regard to the geology of the Laguna, Trigo, and Chocolate mountains. Possibly parts of these ranges escaped the general flooding of the region by the sheets of lava. Probably there was more than one period of extrusion, as has been found to be recorded elsewhere in similar rocks. Much more detailed work is required to determine this point.

The amount of sedimentary rocks of Tertiary age found in the area is small indeed compared to the many hundreds of feet of lavas. Unquestionably volcanism rather than sedimentation was the dominant feature of the period. Much of the Tertiary sedimentary rock is believed to be of terrestrial origin and was probably deposited under conditions not very different from those of the present day. This fact is better shown in the exposures of Tertiary formations south of the area covered by this guide, where stream-laid conglomerates occur.³⁴

The calcareous sediments found in several places within this area and in adjoining parts of California tell a very different story. (See pp. 188-190.) These beds were unquestionably laid down in large bodies of quiet water. They are lacustrine or estuarine. A glance at the map will show that the exposures of these deposits are scattered over a region covering about 2,000 square miles. Only one of them, that near Osborne's Well, is in an area covered by an accurate topographic map, hence the exact altitudes of the others are not known. The best estimates available, however, show that all, including the California area, are at altitudes of approximately 700 feet above sea level. Unfortunately, the paleontologic evidence at hand is not conclusive as regards the character of the waters in which these beds were deposited. It is possible that they were laid down in lakes lying between the mountain ranges. Much more probably, however, they were deposited in an estuary or estuaries extending northward from the Gulf of California. In late Miocene or Pliocene time the gulf had a much greater extension to the north than at

³³ Idem, pp. 30-31.

³⁴ Bryan, Kirk, The Papago country, Ariz.: U. S. Geol. Survey Water-Supply Paper — (in preparation).

present, flooding southern California in the region of the Salton basin.³⁵ Possibly the calcareous beds in the region covered by this report mark the northern extension of this incursion of marine waters.

There was much normal faulting in Tertiary time, some of it on a large scale, and probably there was more than one period of faulting. It resulted in the formation of structural valleys between the upthrown blocks. Folding either did not occur or was of very minor amount.

QUATERNARY TIME.

Our knowledge of Quaternary events in this region is more detailed and complete than that of the older geologic periods. Doubtless there were several divisions of Tertiary time besides those mentioned above. The great masses of lava, for example, probably were not all poured out during one continuous period of eruption. There were interruptions and alternations of conditions. The record of these events is so fragmentary and obscure, however, that it was impossible to work out the details of the Tertiary history. The record of Quaternary events is naturally much more completely preserved, though there is much that is still uncertain or entirely unknown regarding the history of this period. One of the greatest difficulties encountered in interpreting the record is that of differentiating between the older and the younger valley fill, which are lithologically very similar.

Some uncertainty exists as to the division between the Tertiary and Quaternary in this region. Lee³⁶ believes that the uplift that initiated the cutting of the Grand Canyon of the Colorado marks the beginning of the Quaternary period. This uplift was very probably essentially contemporaneous with that which resulted in the deep cutting of the desert valleys. However, Lee elsewhere³⁷ makes the suggestion that the lower portion of the fill in Salt River valley may be Tertiary. He considers that this lower portion may be lacustrine in origin and notably

older than the detrital material above it. Deep wells show that there is a considerable thickness of clay or other fine material beneath the coarser detritus in Salt River valley. Records of wells in Buckeye and Arlington valleys and at Gila Bend show that similar conditions exist in those localities also. Considerable clay was encountered in several of the Southern Pacific Railroad wells on the Gila west of Gila Bend. It is possible that fossil or other evidence may eventually be found which will show that these beds are Tertiary, but until further facts are discovered the most logical conclusion appears to be to consider the deep cutting of the valleys, originally in large part of structural origin, as the first event of the Quaternary period in the region under discussion. Any sediments, whatever their origin, lying in these valleys must then be considered of Quaternary age. The mere fact that the lower part of the fill is apparently of lacustrine origin does not affect the problem of its age. Beds of unquestionably Quaternary age and very probably lacustrine origin occur near Parker, on Colorado River. A temporary lake³⁸ is believed to have existed in Arlington Valley in recent geologic time.

After the valley cutting the conditions were so altered that the streams began to aggrade, and the recently excavated valleys were filled to great depths with detrital material. Basalt flows, the continuation of the basaltic effusions at the end of the Tertiary, occurred at this time. As has already been stated, volcanism did not continue as late in this region as it did in some other portions of the Southwest, notably southern California. It continued intermittently to a time considerably later than that in which the first valley fill was deposited.

When the valleys had been very largely filled with detritus, renewed uplift occurred. In places the recently deposited sediments were faulted and somewhat folded. Degradation recommenced, and much of the material with which the valleys had just been filled was swept out of them.

Before all of the first valley fill had been removed aggradation was resumed and the

³⁵ Kew, W. S. W., Tertiary echnoids of the Carrizo Creek region in the Colorado Desert: California Univ. Dept. Geology Bull., vol. 8, pp. 39-60, 1914.

³⁶ Lee, W. T., Geologic reconnaissance of a part of western Arizona: U. S. Geol. Survey Bull. 352, pp. 62-63, 1908.

³⁷ Lee, W. T., Underground waters of Salt River valley, Ariz., U. S. Geol. Survey Water-Supply Paper 136, p. 114, 1905.

³⁸ Ross, C. P., The lower Gila region, Ariz.: U. S. Geol. Survey Water-Supply Paper — (in preparation).

younger fill was deposited. Volcanism of minor extent occurred during this epoch. Near Bouse, Yuma County, volcanic ash occurs in the fill not far from the present surface. This deposit is probably comparatively recent. Several of the lava flows may be of corresponding age.

In comparatively recent time erosion of the younger fill has commenced, as is shown by terraces cut in it. The present flood plains of the streams lie between the lowest of these terraces. Along both Colorado and Gila rivers other terraces can be discerned above these, but they are discontinuous and apparently not significant.

At the present time both rivers are aggrading in their lower courses. Their channels are gradually being filled by the deposition of fine silts. Both rivers are well known for the large quantities of silt carried by their waters during floods. At all times they are remarkably muddy.

MINERAL DEPOSITS.

This part of Arizona has been extensively prospected. Mineral deposits are now known to occur in every mountain range and in many of the groups of hills within the region. The only hills in which mineral deposits have not been, and in all probability will not be found, are those composed exclusively of Quaternary basalt.

The types of deposits and the minerals found are many and diverse. Mining has been carried on in this region for gold, silver, copper, lead, zinc, mercury, iron, and manganese. There has been some prospecting for tungsten, but no mining for this metal has been done. Fluorite occurs in the Castle Dome district and possibly elsewhere but so far as known has not been developed. Gypsum occurs in some places in the region, but no deposits of commercial importance are known.

Mining is in progress in several of the mountain ranges in this region, but there are no large mines operating at present. In the past the Vulture mine, in the range of the same name; the mines about Kofa, in the S. H. Mountains; the Harqua Hala or Bonanza mine, in the Little Harquahala Mountains; and other less well-known properties have shipped considerable gold ore. Silver and lead were mined for some years in the Castle Dome Mountains.

Gold placers were formerly worked along Colorado River near La Paz and Ehrenberg, in and near the Dome Rock and Plomosa Mountains, and at Gila City on Gila River, at the site of the present town of Dome. Some placer mining is still in progress in the Plomosa and Dome Rock mountains, but elsewhere activity of this sort has almost entirely ceased. The lack of water appears to be the principal obstacle to the successful development of the placers. In the old vein mines the richer and more accessible portions of the ore bodies have been worked out, and lack of transportation facilities and of capital have prevented further development. The Harqua Hala mine is now being reopened for copper. It is possible that many of the mines now abandoned could again be made profitable producers by extending the workings deeper.

At present (1918) there is considerable activity in the small copper mines in the vicinity of Cunningham Pass, in the Harcuvar Mountains. Mining for copper and other metals is being carried on in the Buckskin and Plomosa mountains and to a small extent elsewhere. More or less desultory prospecting is in progress in all the mountain ranges. In 1918 plans were being discussed for a reopening of some of the mines in the vicinity of Kofa.

A detailed discussion of the geologic features of the ore deposits in the region is beyond the scope of this paper, but descriptions of some of the mines will be found in the final report³⁹ now being prepared. Bancroft⁴⁰ has described the deposits in the northern part of the region, and the deposits noted in the southern part appear to be in general similar to the types he describes. According to him there were three periods of mineralization—pre-Cambrian, Mesozoic, and Tertiary. He describes numerous types of deposits belonging to these periods, also the placers in the vicinity of Quartzsite. The reports of the governor of the Territory of Arizona contain many references by W. P. Blake, Territorial geologist, to deposits in this area. Jones has described deposits in the Dome Rock Mountains⁴¹ and near Kofa, in the S. H. Mountains.⁴²

³⁹ Ross, C. P., The lower Gila region, Ariz.: U. S. Geol. Survey Water-Supply Paper — (in preparation).

⁴⁰ Bancroft, Howland, op. cit.

⁴¹ Jones, E. L., jr., Gold deposits near Quartzsite, Ariz.: U. S. Geol. Survey Bull. 620, pp. 45-57, 1916.

⁴² Jones, E. L., jr., A reconnaissance in the Kofa Mountains, Ariz.: U. S. Geol. Survey Bull. 620, pp. 151-164, 1916.

THE FLORA OF THE CHEYENNE SANDSTONE OF KANSAS.

By EDWARD WILBER BERRY.

INTRODUCTION.

The present study is based on collections made by Hill in 1894, Ward and Vaughan in 1896, Ward, Gould, White, and Cain in 1897, and Lee in 1919. These collections were very extensive, but the bulk represented small fragments of the more abundant species, such as the *Sequoia* and *Sapindopsis*. The flora itself as at present known consists of a very small number of species.

The Cheyenne sandstone comprises about 100 feet of gray to yellow friable quartz sandstone with subordinate lenses of dark shale. The sandstone ranges from fine to coarse and contains a few layers of quartz and chert pebbles. It is in the main only slightly consolidated and is very friable and easily eroded. The bedding is extremely irregular and discontinuous, and cross-bedding is obvious throughout and in places extremely pronounced. Logs of silicified wood and *Cycadeoidea minuta* from these beds were recorded by Cragin.¹

The Cheyenne sandstone rests upon "Red Beds" of supposed Permian age and is overlain by the Kiowa shale—shallow-water and lagoon deposits of alternating layers of marl and bituminous clay shale, with a marine fauna that includes many species characteristic of the Washita group of the Texas Cretaceous.

The invertebrates are said by Twenhofel to number about 50 species, of which the following are some of the commoner forms:

Cardium kansasense Meek.
Cyprimeria kiowana Cragin.
Exogyra texana Roemer.
Gryphaea corrugata Say.
Gryphaea navia Hall.
Ostrea quadriplicata Shumard.
Pecten texanus Roemer.
Protocardia texana Conrad.
Schloenbachia belknapi (Marcou).
Schloenbachia peruviana (Von Buch).
Trigonia emoryi Conrad.

In some places the Tertiary overlies the Kiowa; elsewhere the following units in ascending order have been recognized by Gould: Spring Creek clays, Greenleaf sandstone, Kirby clays, and Reeder sandstone. The names are those proposed by Gould and Cragin and have not been formally recognized by the United States Geological Survey. These units are chiefly local phases or lentils in the Kiowa, of little significance except as indicative of local and more or less contemporaneous variations in conditions of deposition, with perhaps a basal member of the Dakota sandstone represented in the "Reeder."

HISTORICAL SUMMARY.

The term "Dakota group" was first used in 1861 by Meek and Hayden² for the lower portion of their section of the Cretaceous of Nebraska, corresponding to No. 1 of the classic Meek and Hayden Upper Missouri section.³ This term or simply Dakota or Dakota sandstone has subsequently been used in innumerable references to local geologic sections throughout the West. The assumption that the Upper Cretaceous of that whole region contained two persistent sandstones—the Dakota at its bottom and the Fox Hills near its top—and the fancied recognition of these sandstones over a wide area have caused much of the confusion and controversy that have arisen over the interpretation of the western Cretaceous.

As originally understood the term Dakota was applied to the pre-Benton Cretaceous, no Lower Cretaceous being then recognized in that region. Unquestionably the typical Dakota sandstone represents the littoral or marginal deposits of the transgressing Benton sea, but that there are similar and somewhat earlier continental or marginal sandstones in

² Meek, F. B., and Hayden, F. V., Acad. Nat. Sci. Philadelphia Proc., vol. 13, p. 419, 1861.

³ Hall, James, and Meek, F. B., Am. Acad. Mem., vol. 5, p. 405, 1856. Meek, F. B., and Hayden, F. V., Acad. Nat. Sci. Philadelphia Proc. vol. 8, p. 63, 1856.

¹ Cragin, F. W., Washburn Coll. Lab. Nat. Hist. Bull., vol. 2, pp. 35-66, 1889.

Kansas, Colorado, the western Black Hills, and presumably elsewhere in this region has been pretty well known for a number of years. Their exact age has been a matter of considerable differences of opinion.

The history of paleobotanic discovery of the so-called Dakota flora has been given in Lesquereux's three memoirs and need not be recounted here except to point out that the collections, a study of which resulted in the identification of over 400 species of plants, were made at different times and places by a number of different collectors, who, as in so much of the early exploratory work in the West, paid little attention to stratigraphic position or locality. Any yellowish or reddish sandstone with impressions of dicotyledonous leaves was Dakota in age, and for a large number of species "Dakota group of Kansas," or at most the county from which the specimens were collected, is all we know of the whereabouts of the outcrop.

Apparently the first to notice marine fossils at the base of the red Cretaceous (Dakota) sandstones was Le Conte.¹ Cragin, while at Washburn College, Topeka, Kans., did much work upon the Cretaceous and published many short paleontologic papers. In 1890 he described a cross-bedded sandstone (the Cheyenne sandstone) which underlay marine beds in southern Kansas and which he considered to be related to the Potomac, Tuscaloosa, Trinity, and "Atlantosaurus beds," and the next year he published the statement that the Cheyenne sandstone was probably of the same age as the Trinity of Texas, the Potomac of the Atlantic Coastal Plain, and the Wealden or Purbeck of Europe. Invariably in his discussions he used the term Comanche as the interchangeable equivalent of the European Neocomian.

The first definite announcement of the flora contained in the Cheyenne sandstone was made by Hill,⁵ who recorded the following species from collections made by Hill, Gould, and Shattuck in 1894:

- Rhus uddeni Lesquereux.
- Sterculia snowii Lesquereux.
- Sassafras mudgei Lesquereux.

¹ Le Conte, J. L., Notes on the geology of the survey for the extension of the Union Pacific Railway, Philadelphia, 1868.

⁵ Hill, R. T., Discovery of a dicotyledonous flora in the Cheyenne sandstone: Am. Jour. Sci., 3d ser., vol. 49, p. 473, 1895; On outlying areas of the Comanche series in Kansas, Oklahoma, and New Mexico: Idem, vol. 50, pp. 205-234, 1895.

- Sassafras cretaceum obtusum Lesquereux.
- Sassafras n. sp.
- Glyptostrobus gracillimus Lesquereux.
- Sequoia sp. (cones).

Cragin's conclusions were given in a paper published in 1895,⁶ in which the section is given as follows:

- Kiowa shales.
- Champion shell bed.
- Cheyenne sandstone { Elk Creek beds { Stokes sandstone
Lanphier shale.
Corral sandstone.

From the "Elk Creek beds" he recorded *Sterculia snowii*, *Sassafras mudgei*, *Sassafras cretaceum*, *Sassafras* sp., *Rhus uddeni*, *Sequoia* sp., and *Glyptostrobus gracillimus*.⁷ Only the first two of these are contained in the collections studied by me.

Other contributors to the subject prior to 1900 were Mudge, Prosser, Jones, Stanton, and Gould. Their results are not pertinent to my present purpose beyond the fact that they show conclusively the presence of a sandstone, the Cheyenne, containing the remains of a land flora in southern Kansas beneath a marine series, the Kiowa shale, carrying a fauna that is correlated with that of the Washita group at the top of the supposed Lower Cretaceous section of Texas as elaborated by Hill.

During his residence in Kansas Twenhofel studied the Cretaceous of the central part of the State, and in a brief paper⁸ published in 1917 he confirmed Cragin's earlier results⁹ that a situation identical with that of southern Kansas prevails in central Kansas. In a more recent article¹⁰ he contends that the Dakota of Kansas and the Washita group of Texas are of the same age, and that both the Cheyenne-Kiowa-"Medicine beds" sequence of southern Kansas and the Mentor-Dakota sequence of central Kansas should be referred to the Comanche series.

The "Dakota flora" of the Denver Basin has recently been revised by Knowlton. As a result of field work by Lee and Cannon during 1916 it has been shown¹¹ that the formation from which Lieut. Beckwith collected the "Dakota" plants from Morrison, Colo., that

⁶ Cragin, F. W., A study of the Belvidere beds: Am. Geologist, vol. 16, pp. 357-385, 1895.

⁷ Idem, p. 367, quoted from Hill.

⁸ Twenhofel, W. H., Kansas Acad. Sci. Trans., vol. 28, pp. 213-223, 1917.

⁹ Cragin, F. W., Am. Geologist, vol. 16, pp. 162-165, 1895.

¹⁰ Twenhofel, W. H., Am. Jour. Sci., 4th ser., vol. 49, pp. 281-297, 1920.

¹¹ Lee, W. T., Am. Jour. Sci., 4th ser., vol. 49, pp. 183-188, 1920.

Lesquereux described is the same as that described by Richardson¹² in 1915 as the Purgatoire formation and referred to the top of the Lower Cretaceous. This formation has also frequently been called "Lower Dakota." Below this, in the type section at Morrison and within the Morrison formation ("*Atlantosaurus* beds") as originally described, there is about 100 feet of friable sandstone and shale containing traces of a flora similar to that found in the overlying sandstone. This flora has been discussed by Knowlton,¹³ who quite rightly concludes that it is Upper Cretaceous.

I am not concerned in this paper with the taxonomic proposals regarding what shall be the stratigraphic limits of the Dakota, but solely with the general relations and their bearing on the geologic history of the region and the boundary between Lower and Upper Cretaceous.

It has been customary for geologists, particularly those who had a leaning toward philosophy, to postulate a rhythm of positive and negative movements of the strand by which the boundaries of the different systems could readily be determined. There may be some physical basis for this conception, but it should be recalled that all series of changes can be considered rhythmic, with some elasticity in the application of criteria, and I am one of those reactionaries who believe that, however imperfect the scheme as devised for the region first and longest studied, namely, Europe, the classic names and approximate limits of the systems should be adhered to; for, after all, the best classifications, whether of geologic time or of formations, igneous rocks, or organisms, are those which are most easily understood and used.

Time is continuous, time boundaries are always subjective, and the time-honored terms Permian or Triassic or "Lower Carboniferous" or Lower Cretaceous are to me as essential to clear thinking and the interchange of geologic ideas among nations as the minutes, hours, and days of the current time scheme, however illogical these may seem in sidereal astronomy.

According to the customary American scheme the Lower Cretaceous should be con-

sidered to have ended with the withdrawal of the Lower Cretaceous sea and the Upper Cretaceous to have begun with the initial transgression of the Upper Cretaceous sea. Where the interval between these two events was long, with continental deposition, much confusion and difference of interpretation results. A classic instance of such differences is the controversy over the boundary between the Cretaceous and Tertiary in the Great Plains and Rocky Mountain region of North America, which the Tertiary sea was so inconsiderate as not to invade. If geology at its inception had concerned itself chiefly with continental deposits and land plants and animals and had ignored marine formations and life the situation would be exactly reversed, and the marine sediments would probably be those in dispute.

On none of the continents, so far as I can discover, did the sea complete a cycle of invasion and withdrawal of what might be called the first magnitude during the Lower Cretaceous epoch. In the Atlantic Coastal Plain no marine Upper Cretaceous deposits earlier than the European Turonian are known except in the Texas area, where marine formations representing a part but not all of the Lower Cretaceous of Europe advance haltingly from the south. The oldest of these formations is the Trinity, which in my judgment is nowhere as old as the Neocomian of Europe. This is followed by the Fredericksburg group, which Hill called Neocomian but which contains a younger fauna. If one disregards Böse's correlations of the Mexican Cretaceous on the ground that Mexico is too remote from the north Texas-Kansas area, Whitney's studies of the fauna of the Buda limestone not only clearly show its Cenomanian age but also show that it is late Cenomanian. Similarly the fauna of the Georgetown limestone is Cenomanian. (Whitney has refrained thus far from making any intercontinental correlations.) It is a striking confirmation of this correlation that the Buda limestone near Austin and hence in the region of more continuous marine conditions than farther north should be immediately overlain by the Turonian Eagle Ford formation. The problem of working out the interfingering of formations between north and central Texas is largely a problem of invertebrate paleontology

¹² Richardson, G. B., U. S. Geol. Survey Geol. Atlas, Castle Rock folio (No. 198), 1915.

¹³ Knowlton, F. H., Am. Jour. Sci., 4th ser., vol. 49, pp. 189-194, 1920.

and would not be mentioned in the present connection if it were not for the necessity of showing that the correlation of the Texas Comanche series with the Lower Cretaceous of Europe is incorrect and can not hope to be ultimately accepted, and because this problem is so intimately bound up with the age of the Cheyenne sandstone.

If there is no marine Lower Cretaceous in Kansas, as I contend, our ideas of the sequence of events from late Lower Cretaceous time into the Upper Cretaceous require to be very greatly modified.

With regard to Twenhofel's proposal to refer the Mentor and Dakota of central Kansas to the Comanche, all that I can say is that while he and before him Cragin and others have written about the Dakota flora, this term is altogether meaningless stratigraphically, except that it denotes in a most general way a change in facies between Lower and Upper Cretaceous floras. The flora of the Cheyenne sandstone, and I presume that in the Mentor formation as well, is no more like that of the Woodbine sand than the Woodbine flora is like that of the several formations of the Montana group, and the reference of the Dakota sandstone—that is, the post-Mentor Dakota sandstone of central Kansas—to the Lower Cretaceous if correct would of necessity carry with it the Bingen sand of Arkansas, the Tuscaloosa formation of Alabama, the Black Creek formation of the Carolinas, and the Magothy formation of New Jersey and Maryland, against whose correlation with the Senonian of Europe by paleozoologists I have been arguing for years, with not very great success.

LOCALITIES.

All the localities from which fossil plants were collected in the Cheyenne sandstone are in the immediate vicinity of Belvidere, Kiowa County, Kans. (See Pl. XLVI.) I give below a transcription of the locality numbers, with the names of the collectors and dates, taken from the United States Geological Survey's records. There appears to be some confusion in the two collections numbered 2224, nor do I have locality numbers for the material collected by Ward and Vaughan in 1896. These defects in the record are immaterial, however, for there is no doubt that all the material studied came from the Cheyenne sand-

stone in this immediate region. Many of the numbers are duplications of identical outcrops and are given only as a matter of record.

773. Black hills near Belvidere; collected by Hill, Gould, and Shattuck, 1894.

2217. Osage Rock at Belvidere, from Nos. 1 and 2 of Hill's section; collected by O. L. Cain, 1897.

2218. One and one-half miles northwest of Belvidere, from No. 3 of Hill's section; collected by Ward and Gould, 1897.

2219. Same as 773. Stokes Hill, 100 yards south of the National Corral; collected by Ward and Gould, 1897.

2220. Stokes Hill, the most northeasterly of Hill's localities; collected by Gould, 1897.

2221. Thompson Creek near the flume, 2 miles northwest of Belvidere; collected by Ward and Gould, 1897.

2222. Champion (Wildcat) Draw, three-fourths mile south of Belvidere; collected by Ward, Gould, and White, 1897.

2223. Same locality and collectors as 2222, from the "Lanphier shales."

2224. Near Medicine Lodge River, 2 miles west of Belvidere (original locality of Ward and Vaughan in 1896); collected by Ward and Gould.

2224. Champion (Wildcat) Draw, right (east) branch, in "Lanphier shales," half a mile south of Belvidere; collected by Ward and Gould, 1897.

2225. One mile southwest of Belvidere, in a draw ("Lanphier shales"); collected by Ward and Gould, 1897.

2226. About 2½ miles due west of Belvidere (fern bed of 1896); collected by Ward and Gould, 1897.

2227. Hills between Spring Creek and Soldier, 4 miles northeast of Belvidere; collected by Ward and Gould, 1897.

2228. Champion (Wildcat) Draw, right (east) branch, "Lanphier shales," half a mile south of Belvidere; collected by Ward and Gould, 1897.

2229. Left bank of middle branch of Champion (Wildcat) Draw, half a mile south of Belvidere; collected by Ward and Gould, 1897.

2230. Draws north of Belvidere ("Lanphier shales"); collected by Ward and Gould, 1897.

2231. Right bank of middle branch of Champion (Wildcat) Draw, half a mile south of Belvidere; collected by Ward and Gould, 1897.

2232. Osage Rock at Belvidere, "Stokes sandstone" below the so-called Champion shell bed; collected by Ward and Gould, 1897.

2233. First draw west of Champion (Wildcat) Draw, half a mile south of Belvidere; collected by Ward and Gould, 1897.

7405. Wildcat Draw, near Belvidere; collected by W. T. Lee, 1919.

7406. Osage Rock, near Belvidere; collected by W. T. Lee, 1919.

CHARACTER OF THE FLORA.

The flora of the Cheyenne sandstone as disclosed in the present study numbers but 23 species. It comprises four ferns representing the families Polypodiaceae and Gleicheniaceae, and all four are representatives of widely



OSAGE ROCK, ABOUT 1 MILE NORTH OF BELVIDERE, KANS.

ranging and more or less well known Cretaceous types. The collections include a supposed cycadophyte seed, but this is of doubtful relationship. There is also a fragment of a trunk of the genus *Cycadeoidea*, which is of somewhat uncertain value, as its exact stratigraphic position has been questioned. There are four coniferophytes and eleven angiosperms. One of these is a supposed monocotyledon, ten are dicotyledons, and there are two forms of uncertain botanic relationships.

The dicotyledons represent the orders Sapindales, Malvales, Thymeleales, and Umbellales and are remarkable for the total absence of a large number of elements generally found in floras of this age. This absence can not be wholly explained by accidents of preservation and discovery and is due, I believe, to the peculiar ecologic grouping resulting from the environment.

The arenaceous portions of the Cheyenne sandstone are very conspicuously cross-bedded. The material is very friable, and the vegetable remains are embedded in all sorts of positions and curled as they are when covered in a dry condition by wind-blown sands. All are coriaceous forms, and the abundant *Sequoia* cones all have their scales shrunken and widely distended as in thoroughly desiccated modern cones. They appear to have blown about and collected in hollows along with the coriaceous leaves that are found in association with them. With a single exception the ferns are found in the clays and evidently were confined largely to stream banks.

The variety of plants in such situations may have been larger than the discovered flora indicates, but it would seem as if in collections so extensive there should be some traces of the other plants preserved if they were growing near at hand.

Although the flora is too small and too remote in time from existing floras to afford satisfactory ecologic data, it does furnish some suggestions. It seems to me to indicate a warm and more or less arid climate, with a sparse vegetation. I picture this vegetation as of meager variety and as having been confined largely to the region of watercourses between which were larger areas of sand-hill or beach-dune country over which the dried leaves and fruits were blown, collecting in the hollows and becoming covered by wind-blown sands. The

clay lenses—for example, Cragin's "Lauphrier beds"—are waterlaid and might represent seasonal rainfall and flood-plain or playa deposits or normal stream sedimentation, and it is possible that some of the sands had a like origin.

There is no evidence of aridity in any of the Cretaceous floras with which the Cheyenne sandstone flora may be compared, whether such comparisons are made with the Patapsco and Fuson floras, on the one hand, or the Woodbine, Dakota, and Tuscaloosa floras, on the other. I believe, therefore, that the Cheyenne flora does not represent general conditions but is purely an expression of the local environment and perhaps represents a wide sandy coastal plain or fluctuating beaches backed by dunes, and that farther inland a more varied and normal flora probably existed throughout the period when the shallow sea was migrating back and forth across southern Kansas.

A sample of the Cheyenne sandstone was submitted to Mr. Marcus I. Goldman, who has kindly furnished the appended observations:

Macroscopic examination.—A solid but friable fine-grained sandstone of a pale lavender-brown color characteristic of moderately carbonaceous sandstones. No lamination. Contains curled and wrinkled leaf impressions suggestive of deposition in a dry condition, hence in wind-blown sand.

Mechanical analysis.—The rock could be easily rubbed down into its constituent grains. On sieving these divided as follows: Fine sand through 60 on 100 mesh, 12.9 per cent, 0.45–0.26 millimeter; very fine sand through 100 on 200 mesh, 82.2 per cent, 0.26–0.04 millimeter; extra fine sand through 200 mesh, 4.9 per cent, less than 0.04 millimeter. Microscopic examination showed that the two finer parts contained thoroughly disintegrated grains. The coarsest, however, consisted largely of compound grains which yielded slowly to disintegration, so the following rough figures may be taken: Fine sand, 5 per cent; very fine sand, 90 per cent; extra fine sand, 5 per cent. In either case the great predominance of the very fine sand is obvious. This predominance of a single size at once suggests wind action, but comparison with dune sands (cf. my paper on the Catahoula sandstone,¹⁴ where several analyses are assembled) shows that the maximum is in the size next finest to that which forms the maximum in typical dune material. I have looked up the large collection of analyses given by Udden¹⁵ and find that in this character the sample resembles the finer sand carried by the wind out of other deposits. Thus it corresponds with only two of his dune sands—No. 219, which is the finest material gathered at the crest of a dune, and No. 248, from a blown field.

¹⁴ Goldman, M. I., Petrographic evidence on the origin of the Catahoula sandstone of Texas: *Am. Jour. Sci.*, 4th ser., vol. 39, p. 269, 1915.

¹⁵ Udden, J. A., Mechanical composition of elastic sediments: *Geol. Soc. America Bull.*, vol. 25, pp. 655–744, 1915.

On the other hand, the majority of samples of what he calls incipient wind-blown sand, which is sand blown out of other deposits, have this composition, as do also his lee sands, which are the finer material blown beyond the body of a dune.

Microscopic examination.—(I) Thin section: Three characters are conspicuous in the thin section of the original rock, namely, (a) its porosity, which is evidently primary—that is, not produced by grinding the thin section—and is a character of wind-deposited material;¹⁶ (b) the angularity of most of the grains; (c) the absence of a recognizable deposit of secondary quartz on the outside of the grains. In many cases it can be definitely proved, by the presence of inclusions throughout the grain, that there is no outer coat of secondary quartz, and the rough angularity of the grains does not suggest secondary growth, which tends to restore crystal form, but, if anything, rather solution. (II) Disintegrated sand: The disintegrated material can be studied to greater advantage because it can be immersed in liquids of different indices of refraction. Thus by immersing in a liquid of index about 1.55 the inner structure of the quartz grains and any possible boundary between nucleus and secondary quartz can be more readily recognized. Immersing in a liquid of index about 1.65, on the other hand, brings out brilliantly the surface form and texture. Much more could be observed, especially in the latter liquid, than the time at my disposal permitted, but I can make the following generalizations: (a) None of the portions, not even the coarsest, reveal any unusual abundance of rounded grains; rather the opposite. (b) The surface of grains is not frosted, as is characteristic of wind-blown sand, nor pitted, as if subjected to much solution, but rather rough and chipped-looking, as might be the result of mechanical wear. (c) Under the favorable conditions afforded by immersion in a liquid of index about 1.55, no secondary silicification could be detected. (d) In the finest size a few very small well-rounded grains were found, the smallest having a diameter of about 0.025 millimeter and being exceptionally perfectly rounded. Such a grain could probably be produced only by prolonged wind action.¹⁷

The main problem of fact, in spite of these observations, still concerns the cause of the present form of the grains. Secondary silicification is often very veiled, and in the absence of comparative studies I am not prepared to commit myself as to the possibility of solution having acted on the grains. These two factors affect not only the form but also the size of the grains. However, the coherence of the observations made favors the belief in their correctness. They lead to the following conclusion.

The portion of the Cheyenne sandstone represented by this sample is nothing like an eolian deposit in an arid region, nor even a part of a permanent dune area in a humid climate, but merely an accumulation of material blown by the wind out of a deposit of some other origin. Only an extensive field study could disclose the main accumulation from which this is separated and other possible associated facies and lead to a complete and satisfactory interpretation. From the roughness of the sand grains I would be inclined to assume rather a delta than a beach deposit as the dominant type. The very

small, perfectly rounded grain noted appears entirely out of place as the product of the conditions under which the sandstone seems likely to have been formed and must therefore be assumed to be the product of an earlier cycle in the history of the grain, unless it is assumed that in a deposition of secondary silica the larger grains have been favored so that only the smallest grains retain their original form; but this seems to me incompatible with the uniform size of the larger grains.

As brought out in the paper on the Catahoula sandstone there are many more factors that might have been considered, but being limited in time and having no assistance for such work I have selected the few that seemed most rapidly determinable and most important.

A single sample whose position in the local section is unknown can be conclusive only for that one sample. The foreset bedding of which I have seen pictures suggests delta deposition, but no one has made field studies of the Cheyenne sandstone with the object of determining the origin of the sediments or the method of sedimentation, and Mr. Goldman's report is therefore chiefly significant in indicating what definite results might be obtained in this region of an oscillating Cretaceous strand by a careful study of the problem.

The plants and their method of occurrence conclusively indicate a sparse vegetation, at least seasonal dryness, and accumulation by the wind. This I am sure was a local condition, as previously stated. Whether these facts do or do not indicate beaches, interstream sand hills, or delta deposits can be determined only by future studies.

AGE OF THE FLORA.

Ignoring for the present the general relations and the implications resulting from the age of the overlying Kiowa shale or the supposed equivalent beds in Texas, as discussed in the preceding section, and considering only the evidence of the fossil plants, I may note that ten of the 23 species are positively identified as "Dakota" forms and two additional species are tentatively so identified. Four others are peculiar to the Cheyenne sandstone. The type localities of the remaining seven species were the Cenomanian of Bohemia (one species), the Atane beds of Greenland (two species), and the Patapsco formation of Maryland (four species).

Of the so-called Dakota forms in the Cheyenne flora the following species were previously known from only the "Dakota": *Cladophlebis dakotensis* (Lesquereux), *Cycadeospermum line-*

¹⁶ Goldman, M. L., op. cit., pp. 286-281.

¹⁷ Idem, pp. 271-272.

atum Lesquereux, *Sequoia condita* Lesquereux, *Abietites ernestinae* Lesquereux, *Sterculia mucronata* Lesquereux, and *Sassafras mudgii* Lesquereux. Of these the first two were found near Delphos, Kans.; *Sequoia condita*, one of the most abundant forms in the Cheyenne sandstone, was known simply from "Kansas" and might really have come originally from the Cheyenne sandstone; *Abietites ernestinae* was from Decatur, Nebr.; *Sterculia mucronata* was from Ellsworth County, Kans.; and *Sassafras mudgii* was recorded from Salina River, Kans., and Evans quarry, S. Dak. According to Stanton the outcrops of the Dakota sandstone at Delphos, in Ellsworth County, and along Salina River, in Kansas, and at Decatur, Nebr., are in the upper part of the Dakota, the beds at Decatur being within 300 feet of the top. Hence the species common to these localities tend to emphasize the transitional character of the Cheyenne flora.

Five of the remaining six species common to the Dakota are of still more value in that they have all been recorded from other regions where the age is less a matter of doubt. The sixth, *Asplenium dicksonianum* Heer, is of slight value in this connection, as it is probably a composite species. It has been recorded from both older and younger formations, namely, Tuscaloosa, Raritan, Patapsco, Lakota, Kome, Atane, Kootenai, and the Upper Cretaceous of Sakhalin Island. *Gleichenia nordenskioldi* was described originally from material collected in the Kome beds of Greenland and identified by Lesquereux in specimens from the Dakota at Fort Harker, Kans. I have identified the Cheyenne sandstone specimens as this species because they are identical with those described under that name by Lesquereux, but neither these nor Lesquereux's specimens can be distinguished from another of Heer's nominal species of *Gleichenia*, namely, *Gleichenia zippei*, which has been recorded all over the Northern Hemisphere at horizons ranging from Lower Cretaceous to Senonian and has been found in the Atlantic Coastal Plain in the Raritan and Magothy formations. *Abietites longifolius* ranges through the Potomac group of Maryland and Virginia and is found in the Raritan formation in New Jersey and in the Fuson formation of the Black Hills. *Sapindopsis magnifolia* is a Patapsco species, *Sterculia towneri* (Lesquereux) is found in the

Magothy formation, and *Arabiopsoides cretacea* (Newberry) is found in the Raritan and Magothy formations of the Atlantic Coastal Plain.

A prominent element in the Cheyenne sandstone flora consists of the three nominally distinct species of *Sapindopsis*, which are equally prominent in the Patapsco formation of Maryland and Virginia. One of these is also probably present in the true (later) Dakota flora, and another has been recorded from the Fuson formation of the Black Hills, although the latter is not entirely characteristic. This considerable Patapsco element in the Cheyenne flora is of considerable interest, for it includes, in addition to the abundant remains of these three species of *Sapindopsis*, a characteristic *Abietites* (*A. longifolius*). These three forms of *Sapindopsis* are distinguished chiefly by the size of their leaflets and probably in both floras represent slight variants of a single botanic species.

The Patapsco flora has been rather definitely correlated with the Albian stage of Europe.¹⁸ I do not regard the community of *Sapindopsis* and *Abietites* in the Cheyenne and Patapsco as indicating synchronicity, for the following reasons. The Patapsco flora contains 41 species that persist into it from the older Lower Cretaceous. Only one of these, the *Abietites*, occurs in the Cheyenne, and it is also present in the Atane beds of Greenland and the Raritan formation of New Jersey. The Patapsco flora numbers 83 species, and of this large number only two have been found in the immediately overlying Raritan formation. Neither of these occurs in the Cheyenne.

The Cheyenne entirely lacks the older elements that serve to distinguish the Patapsco from the Raritan and stamp its age as Albian. For example, the following fern genera of the Patapsco are not found in the Cheyenne: *Ruffordia*, *Acrostichopteris*, *Knowltonella*, *Cladophlebis*, *Dryopteris*, *Onychiopsis*, *Sagenopteris*, *Tempskya*, *Seleropteris*, and *Thinnfeldia*; the following cycadophyte genera of the Patapsco are not found in the Cheyenne: *Ctenopteris*, *Zamiopsis*, *Nilsonia*, *Zamites*, *Dichotozamites*, and *Podozamites*; and the following coniferophyte genera of the Patapsco are not found in the Cheyenne: *Nageiopsis*, *Brachyphyllum*, *Araucarites*, *Pinus*, *Frenelopsis*, *Sphenolepis*,

¹⁸ Berry, E. W., Maryland Geol. Survey, Lower Cretaceous, p. 172 1911.

and *Widdringtonites*. The vast majority of these are old genera which became extinct before the dawn of the Upper Cretaceous and which give the Albian facies to the Patapsco. Even as regards the angiosperm element of the Patapsco, which might be expected to show more similarities to only slightly younger formations, the following genera of the Patapsco are not represented in the Cheyenne: *Cyperacites*, *Plantaginopsis*, *Alesinaphyllum*, *Populus*, *Populophyllum*, *Nelumbites*, *Menispermities*, *Celastrrophyllum*, *Cissites*, *Araliaephyllum*, *Hederaephyllum*, and *Aristolochiaephyllum*.

The angiosperms of the Cheyenne flora, comprising only eleven species of six genera, contain but two genera that are found in the Albian (*Sapindopsis* and *Sassafras*).

Moreover, the Cheyenne flora entirely lacks those supposed Dakota sandstone species which are common in the Woodbine sand of Texas, the Bingen sand of Arkansas, the Tuscaloosa formation of Alabama, and the Raritan, Magothy, and allied formations of the Atlantic coast region and which clearly show that the so-called Dakota flora as it stands in the literature is not a chronologic unit and that there

is a Dakota sandstone which is approximately of the same age as these formations and which I am inclined to consider of Turonian age according to European standards.

I regard the Cheyenne flora as clearly of the same general facies as those of the Upper Cretaceous formations that immediately succeeded the Cheyenne sandstone in time and as set apart from any known Lower Cretaceous floras by the absence of the characteristic Lower Cretaceous element in part exemplified by the Patapsco genera of ferns, cycads, and conifers enumerated in a preceding paragraph.

The Cheyenne flora is unquestionably older than the flora of the Woodbine sand of Texas, for although the latter also consists largely of so-called Dakota forms there is not a single species that is common to the Cheyenne and Woodbine, and the "Dakota" species of the Woodbine are nearly all the common forms of Coastal Plain formations of known age. I have recently completed a study of the Woodbine flora,¹⁹ so that these statements are authoritative.

The range of the plants found in the Cheyenne sandstone is given in the appended table of distribution.

Distribution of flora of Cheyenne sandstone.

	Dakota sandstone.	Tuscaloosa formation.	Raritan formation.	Magothy formation.	Black Creek formation.	Patuxent formation.	Patapsco formation.	Fuson formation.	Lakota formation.	Kome beds.	Atane beds.	Patoot beds.	Kootenai formation.	Cenomanian.	Emscherian.	Upper Cretaceous, Sakhalin Island.
<i>Cladophlebis dakotensis</i> (Lesquereux) Berry.....	✓															
<i>Asplenium dicksonianum</i> Heer.....	×	×	×				×		×				×			
<i>Gleichenia nordenskiöldi</i> Heer.....	×									×						
<i>Gleichenia? bohémica</i> (Corda) Berry.....											×	×		×		×
<i>Cycadeoidea munita</i> Cragin.....																
<i>Cycadeospermum lineatum</i> Lesquereux.....	×															
<i>Sequoia condita</i> Lesquereux.....	×															
<i>Cupressinoxylon cheyennense</i> Penhallow.....																
<i>Abietites ernestinae</i> Lesquereux.....	✓															
<i>Abietites longifolius</i> (Fontaine) Berry.....	?		?			✓	×	×								
<i>Arundo groenlandica</i> Heer?.....											×	×			×	
<i>Sapindopsis variabilis</i> Fontaine.....																
<i>Sapindopsis magnifolia</i> Fontaine.....																
<i>Sapindopsis brevifolia</i> Fontaine.....																
<i>Sapindopsis belviderenensis</i> Berry.....																
<i>Sterculia towneri</i> (Lesquereux) Berry.....																
<i>Sterculia mucronata</i> Lesquereux.....	✓															
<i>Sassaparilla mudgii</i> Lesquereux.....															?	
<i>Aralia ravniana</i> Heer.....				×							×					
<i>Aralia polymorpha</i> Newberry.....																
<i>Araliopsisoides crotacea</i> (Newberry) Berry.....																
<i>Carpolithus belviderenensis</i> Berry.....																
<i>Festmantelia oblonga</i> Ward.....								✓								

¹⁹ Berry, E. W., The flora of the Woodbine sand at Arthurs Bluff, Tex.: U. S. Geol. Survey Prof. Paper 129, pp. 153-181, 1922.

SYSTEMATIC DESCRIPTIONS.

Phylum PTERIDOPHYTA.

Class LEPTOSPORANGIATAE.

Order POLYPODIALES.

Family POLYPODIACEAE.

Genus CLADOPHLEBIS Brongniart.

Cladophlebis dakotensis (Lesquereux) Berry.

Pteris dakotensis Lesquereux, U. S. Geol. Survey Mon. 17 (Flora of the Dakota group), p. 24, pl. 1, figs. 2, 3, 1892.

This species, the type material of which was collected 10 miles northeast of Delphos, Kans., was described as follows by Lesquereux:

Ultimate pinnae linear-lanceolate, pinnately deeply cut into oblique equal subopposite lanceolate blunt-pointed and subfalcate pinnules, connate above the base, entire, close but disconnected above; median vein thin, distinct; secondaries opposite, 6-7 pairs, simple, curving upward in passing to the borders.

This form is obviously to be referred to the genus *Cladophlebis*, which was so abundant during the Mesozoic era. It was referred to *Pteris* by Lesquereux, as was the habit among earlier paleobotanists. The material which Lesquereux had and that from the Cheyenne sandstone are both too meager for critical comparisons with other described species of *Cladophlebis*. The two specimens from the Cheyenne sandstone came from Thompson Creek near the Flume, 2 miles northwest of Belvidere (2221).

Genus ASPLENIUM Linné.

Asplenium dicksonianum Heer.

Asplenium dicksonianum Heer, Flora fossilis arctica, vol. 3, Abt. 2, p. 31, pl. 1, figs. 1-5, 1874; vol. 6, Abt. 2, pp. 3, 33, pl. 2, fig. 2; pl. 32, figs. 1-8, 1882.

Dawson, Roy. Soc. Canada Trans., vol. 1, sec. 4, p. 11, 1883; vol. 3, sec. 4, p. 5, pl. 3, fig. 1, 1885; Canada Geol. Survey Ann. Rept., new ser., vol. 1, p. 76, 1886; Roy. Soc. Canada Trans., vol. 10, sec. 4, p. 91, 1892.

Lesquereux, The flora of the Dakota group, p. 24, pl. 1, fig. 1, 1892.

Newberry, The flora of the Amboy clays, p. 39, pl. 1, figs. 6, 7; pl. 2, figs. 1-8; pl. 3, fig. 3, 1896.

Ward, U. S. Geol. Survey Nineteenth Ann. Rept., pt. 2, p. 704, pl. 170, fig. 1, 1899; Jour. Geology, vol. 2, pp. 259, 261, 1894.

Fontaine, in Ward, U. S. Geol. Survey Nineteenth Ann. Rept., pt. 2, p. 664, pl. 162, figs. 6-8, 1899 (not Fontaine, 1888).

Kurtz, Contribuciones á la palaeophytologia argentina, III: Mus. La Plata Rev., vol. 10, p. 49, 1899 [1902].

Berry, Torrey Bot. Club Bull., vol. 38, p. 409, 1911; New Jersey Geol. Survey Bull. 3, p. 68, pl. 5, figs. 3, 4, 1911; Maryland Geol. Survey, Upper Cretaceous, p. 767, 1916; U. S. Geol. Survey Prof. Paper 112, p. 53, 1919.

This species was described by Heer in 1874 from material found in the Kome beds (Lower Cretaceous) of Greenland. It was subsequently identified by Heer in material from the much later Atane beds (Upper Cretaceous) of Greenland; Dawson reported it from a number of localities in the Kootenai formation (Lower Cretaceous) of British Columbia, although these records are questionable; and Fontaine and Ward described it from specimens obtained in the Lower Cretaceous of the Black Hills. It is also reported by both Lesquereux and Ward from the Dakota sandstone, and by Kurtz from Argentina. It seems very doubtful if these specimens can all be the same plant, and the geologic range alone suggests that the earlier and the later forms may be distinct. The Lower Cretaceous forms certainly suggest a relationship with those widespread types of sterile fronds variously identified as *Thyrsopteris* or *Onychiopsis*, and they may be compared with *Onychiopsis goepperti* (Schenk) Berry. The Upper Cretaceous forms suggest *Anemia* rather than *Asplenium* and are much like the widespread Eocene species *Anemia haydenii* (Lesquereux) Cockerell and *Anemia subcretacea* (Saporta) Gardner and Ettingshausen. However, in the absence of representative material from the different horizons, it seems unwise to attempt any segregation at the present time, and the synonymy is cited in full for the use of some future student who may have access to enough material to enable him to make an accurate revision and segregation of this so-called species. Attention should also be called to its resemblance to the form occurring in the Upper Cretaceous of Greenland, the Raritan formation of New Jersey, and the Tuscaloosa formation of Alabama which goes by the name *Dicksonia groenlandica* Heer, although the ground for considering it a *Dicksonia* is entirely inconclusive.

Besides occurring at the localities named above the present species is abundant in the Raritan formation of New Jersey and Maryland, and material that is absolutely identical with the New Jersey Raritan material which I have seen and with that from the Dakota sandstone is present in the Tuscaloosa formation of

Alabama and the Cheyenne sandstone of southern Kansas. I have recently received a fine specimen from northeastern New Mexico from a sandstone that appears to represent the Purgatoire formation.

The specimens from the Cheyenne sandstone, all of which are fragmentary, were found in brown clay in a draw on Medicine Lodge Creek, 3 miles above Belvidere (collected by Ward and Vaughan, 1896, no number); $1\frac{1}{2}$ miles northwest of Belvidere (2218); near Medicine Lodge Creek, 2 miles west of Belvidere (2224, same locality as that first cited); and $2\frac{1}{2}$ miles due west of Belvidere (2226).

Order **GLEICHENIALES.**

Family **GLEICHENIACEAE.**

Genus **GLEICHENIA** Smith.

Gleichenia nordenskiöldi Heer.²⁰

Plate XLVII, figure 1.

Gleichenia nordenskiöldi Heer, *Flora fossilis arctica*, vol. 3, Abt. 2, p. 50, pl. 9, figs. 6-12, 1874; vol. 6, Abt. 2, p. 8, pl. 1, figs. 1, 1a, 1882.

Lesquereux, U. S. Geol. and Geog. Survey Terr. Ann. Rept. for 1874, p. 334, pl. 2, fig. 5, 1876; Cretaceous and Tertiary floras, p. 26, pl. 1, figs. 1, 1a, 1883; U. S. Geol. Survey Mon. 17, p. 25, 1892.

This species was described originally by Heer from material collected in the Kome beds of western Greenland. Species of *Gleichenia* are very abundant throughout the Cretaceous section of that region, and Heer founded very many species on this material, more than seem warranted. The stratigraphic boundary between the Kome and Atane beds has been shown by subsequent workers to be very indefinite, and the Atane beds are present at the Kome locality, a fact which may account for the range accredited to a large number of the species.

Lesquereux subsequently identified *Gleichenia nordenskiöldi* from the Dakota sandstone at Fort Harker, Kans. His material was not very convincing and perhaps should not have received a specific name. Material

identical with that of Lesquereux is not uncommon in the Cheyenne sandstone, and I have used the same name for it, although it should be borne in mind that neither Lesquereux's material nor mine is distinct from what has commonly been called *Gleichenia zipppei* Heer,²¹ which has been identified, often wrongly, I believe, at a large number of localities and horizons.

The unwarranted determination of unidentifiable scraps by Ward and especially by Fontaine has almost completely obscured the stratigraphic value of any material that they described. The specimen from Dutch Gap, Va., which Fontaine referred to this species not only differs from the type material but might readily represent the terminal portion of half a dozen different Patuxent species of ferns. Similarly the specimens from the Knoxville formation which Fontaine referred to *Gleichenia nordenskiöldi* are not only not that species but they are not even all the same thing, and the fact that these identical fragments were also referred by Fontaine to *Pecopteris*, *Aspidium*, and *Osmunda*, as well as to *Gleichenia*, is a fitting commentary on both the character of the material and the critical value of Fontaine's results.

What I have called *Gleichenia nordenskiöldi* is found in the Cheyenne sandstone in clay $2\frac{1}{2}$ miles due west of Belvidere (2226), also described as a draw on Medicine Lodge Creek, 3 miles above Belvidere (fern bed, no number), collected by Ward and Vaughan in 1896.

Gleichenia? bohémica (Corda) Berry.

Plate XLVII, figure 2.

Pecopteris bohémica Corda, in Reuss, *Versteinerungen der böhmischen Kreideformation*, p. 95, pl. 49, fig. 1, 1846.

Heer, *Flora fossilis arctica*, vol. 3, Abt. 2, p. 96, pl. 26, fig. 17a, 1874; vol. 7, p. 6, pl. 58, fig. 4, 1883.

Engelhardt, *Naturf. Gesell. Isis in Dresden Abh.*, 1891, No. 7, p. 86.

Kryshstofovich, *Coll. Sci. Imp. Univ. Tokyo Jour.*, vol. 40, art. 8, p. 31, fig. 2, 1918.

This species was described by Corda in 1846 from material obtained in the Cenomanian of Bohemia. It was subsequently recorded from the same horizon in Saxony. Heer referred a number of Greenland specimens to it, and lately Kryshstofovich has recorded it from the Upper Cretaceous of Sakhalin Island. If these

²⁰ The following do not belong to this species:

Gleichenia nordenskiöldi Fontaine, U. S. Geol. Survey Mon. 15, p. 119, pl. 21, fig. 11, 1890.

Gleichenia nordenskiöldi Fontaine, in Ward, U. S. Geol. Survey Mon. 48, p. 231, pl. 65, figs. 24-29, 1906.

Pecopteris strictinervis Fontaine. Fontaine, in Diller and Stanton, *Geol. Soc. America Bull.*, vol. 5, p. 450, 1895; in Stanton, U. S. Geol. Survey Bull. 133, 1895, p. 15, [1896].

Aspidium heterophyllum Fontaine. Fontaine, in Diller and Stanton, *op. cit.*, p. 450; in Stanton, *op. cit.*, p. 15.

Osmunda dicksonioides Fontaine. Fontaine, in Diller and Stanton, *op. cit.*, p. 450; in Stanton, *op. cit.*, p. 15.

²¹ Heer, Oswald, *Flora fossilis arctica*, vol. 1, p. 79, pl. 43, fig. 4, 1868.

records all represent the same species, it was evidently a wide-ranging type in the earliest stage of the Upper Cretaceous, which spread from the Arctic region southward into North America, Europe, and Asia. There are five specimens in the Cheyenne sandstone that appear to be identical with Heer's Greenland forms, but as they are preserved in a coarse sandstone their detailed characteristics are obliterated. The pinnules are coriaceous, long, and narrow and somewhat resemble what Heer²² called *Gleichenia rigida*.

Although details of frond habit and fructification are lacking I have ventured to transfer this form from *Pecopteris* to *Gleichenia*, as it appears to be congeneric with the numerous Cretaceous forms of that genus.

It was found in the Cheyenne sandstone on the left bank of the middle branch of Champion (Wildcat) Draw, half a mile south of Belvidere (2229).

Phylum **CYCADOPHYTA**.

Order **CYCADEOIDALES**.

Genus **CYCADEOIDEA** Buckland.

Cycadeoidea munita Cragin.

Cycadeoidea munita Cragin, Washburn College Lab. Nat. Hist. Bull., vol. 2, p. 65, 1889.

Ward, U. S. Geol. Survey Nineteenth Ann. Rept., pt. 2, p. 541, 1899.

Hill²³ states that there is some doubt as to the occurrence of this specimen at this horizon. Lester F. Ward, who subsequently visited the locality, states that he was satisfied that it could not have come from the Cheyenne sandstone but may have weathered out from the overlying "Reeder sandstone." The material, which is only a fragment, has never been studied by a competent person, although Ward states that it is surely a fragment of a cycad trunk.

Whatever its true horizon it is of interest as one of the latest authentic occurrences of this type of plant.

Genus **CYCADEOSPERMUM** Saporta.

Cycadeospermum lineatum Lesquereux.

Cycadeospermum lineatum Lesquereux, U. S. Geol. Survey Mon. 17, p. 30, pl. 1, fig. 14, 1891 [1892].

This seed, which was found 10 miles north-east of Delphos, Kans., was described by Lesquereux as follows:

Seed oblong-ovate, slightly falcate, rounded at the lower end, short acuminate at the other; testa smooth, transversely lincate, the lines distant, parallel; carena clearly marked longitudinally on both sides, the inner concave, the outer rounded.

Length 1 to 1.5 centimeters; width about 6 millimeters, somewhat compressed. Testa thick, shining, and ligenous.

Cycadophyte seeds are not so inequilateral, and the present form is probably angiospermous. This genus was proposed for Jurassic forms, of which many have been described. A few have been described from both Lower and Upper Cretaceous material. The Cheyenne form is certainly identical with Lesquereux's type. Whether or not it is congeneric with the other species referred to *Cycadeospermum*, or whether indeed it represents the seed of a cycadophyte and not an angiosperm, can not be determined. My impression is that it belongs to the latter rather than the former.

Material identical with Lesquereux's type is found in the Cheyenne sandstone 1½ miles northwest of Belvidere (2218) and near Medicine Lodge Creek, 2 miles west of Belvidere (2224).

Phylum **CONIFEROPHYTA**.

Order **CONIFERALES**.

Family **CUPRESSINACEAE**.

Genus **SEQUOIA** Endlicher.

Sequoia condita Lesquereux.

Plate XLVIII, figures 1-11.

Sequoia condita Lesquereux, U. S. Geol. and Geol. Survey Terr. Bull., vol. 1, p. 391, 1875 [1876]; Ann. Rept. for 1874, p. 355, pl. 4, figs. 5-7, [1876]; U. S. Geol. Survey Terr. Rept., vol. 8 (Cretaceous and Tertiary floras), p. 32, pl. 1, figs. 5-7, 1883; in Cook and Smock, Report on clay deposits in New Jersey, p. 29, 1878.

The inextricable confusion that results from the identification of detached fragments of coniferous foliage when they can not be checked by fruits or in some other way is well illustrated by the forms that are variously referred to *Glyptostrobus gracillimus* Lesquereux, *Sequoia gracillima* Newberry, *Widdringtonites reichii* Heer, etc. In volume 6 of the final reports of the United States Geological Survey of the Territories Lesquereux gave figures of a plant which he had named some years earlier *Glyptostrobus gracillimus* and which he compared with *Frenelites reichii* of Ettingshausen. When

²² Heer, Oswald, *Flora fossilis arctica*, vol. 1, p. 80, pl. 44, fig. 1, 1868.

²³ Hill, R. T., *Am. Jour. Sci.*, 3d ser., vol. 50, p. 212, 1895.

Newberry described the flora of the "Amboy clays" (Raritan formation) he renamed Lesquereux's species *Sequoia gracillima* because he found associated with similar foliar remains in New Jersey elongate cones with scales resembling those of a *Sequoia*. He commented on the resemblance of these cones to *Geinitzia*, but the matter rested here until I compared specimens of the so-called *Sequoia gracillima* cones with those of the European *Geinitzia formosa* Heer and found the two to be identical. In the European Upper Cretaceous these cones were found attached to foliage of a very different type from *Glyptostrobus gracillimus* or *Sequoia gracillima*, although in America the cones were always detached. Foliage like that of *Geinitzia formosa* was found, however, associated with them. It seemed obvious that the cones referred to *Sequoia gracillima* were those of *Geinitzia formosa*, and accordingly I so assigned them. I had collected hundreds of these cones and had abundant comparative material. When I revised the Raritan flora I had much larger collections than those of Newberry, and I found that the foliage which he had called *Sequoia gracillima* was identical with what he had identified as *Widdringtonites reichii* (Ettingshausen) Heer.

These remains are abundant in the Atlantic Coastal Plain as far south as Alabama and have never been found with ovulate cones, although the staminate cones are not uncommon. Thus the slender conifer in the East is *Widdringtonites*. Whether Lesquereux's *Glyptostrobus gracillimus* also represents this genus or not I do not know. I suspect that in spite of minor and not very obvious differences *Glyptostrobus gracillimus* is none other than *Sequoia condita*, which Lesquereux described in Hayden's report for 1874 from very incomplete material collected at Fort Harker and Clay Center, Kans.

The most abundant plants in the Cheyenne sandstone are graceful, delicate coniferous branches bearing numerous distinctive cones identical with the one referred to *Sequoia condita* by Lesquereux, as is the foliage, which has been recorded in the literature of the Cheyenne sandstone as *Glyptostrobus gracillimus* (Ward) and *Sequoia gracillima* (Knowlton). The collections naturally contain many specimens of detached cones and many specimens of foliage lacking cones, but the evidence

is as strong as it can possibly be that when cones and foliage are found in union in a dozen specimens those that are found separated in the same bed are none other. I have specimens of cones from six localities and of the foliage from thirteen localities around Belvidere.

Moreover, the foliage shows considerable variation in the extent to which the leaves are pointed or obtuse, appressed or spreading, depending not only on a natural amount of variation but also on whether it represents shoots of the year or older twigs, and furthermore the appearance differs greatly with the nature of the matrix, the extent to which iron salts have been deposited along the channels formed by the twigs, and other conditions. The specimens found in the sandstones appear different from those found in the clays, and some specimens in the clays which were much incrustated suggested at first sight the genus *Brachyphyllum*.

Before describing the species as fully as the large collection studied permits, I would like to point out that *Sequoia condita* is not related to *Widdringtonites*, *Juniperus*, *Glyptostrobus*, or *Sphenolepis*—genera in which the foliage is comparable—and it is perfectly distinct from *Sequoia fastigiata*. It is known only from the Cheyenne sandstone and from the true Dakota of Kansas. In the absence of attached cones the foliage might be referred to any one of several genera, or its variants might be referred to several different species in as many genera. Taken together, they demonstrate that it is a *Sequoia*, and I do not feel the slightest doubt but that all the material from the Cheyenne sandstone represents a single botanic species. It may be described as follows: Twigs rather rigid, pinnately branched, slender elongate; covered with small, decurrent, crowded leaves varying from appressed to spreading falcate, thick and coriaceous, acute or obtusely pointed, slightly keeled but without vein. The leaves are arranged in a spiral phyllotaxy which becomes higher with the elongation of the twigs. In old twigs 2 to 3 millimeters in diameter they are scattered, spreading, and falcate. Their blunt tip is more apparent than real and is due to their usual or partial preservation in the form of casts. The variations in appearance are well shown in the accompanying figures. The cones vary from prolate to nearly spherical in

form and consist of about 22 scales spirally arranged, as compared with about 30 in the cones of the modern redwood. The axis is stout and fusiform. The scales have a thin rounded peduncle expanding distad into a rhomboidal peltate tip only slightly wider than high, with a wrinkled marginal face surrounding a central laterally elongated umbilicus. Length of cone (maximum), 2.4 centimeters; diameter (maximum), 1.8 centimeters. Average size somewhat smaller. Length of scale (maximum), 8 millimeters; width, 6.5 millimeters; height, 4.5 millimeters. These cones are remarkably like those of the existing redwood (*Sequoia sempervirens*) in every respect—size of axis, shape of scales, etc.—except that the scales are less numerous in the fossils and the maximum size of the scales is about six-sevenths that of the average redwood scale. The average size of the fossil cones is from two-thirds to five-sevenths that of the modern cones.

The condition of preservation of these cones is a strong argument in favor of the eolian character of the sandstone. All have the scales somewhat shriveled and widely separated and are exactly comparable to thoroughly dried redwood cones. They are exceedingly abundant in the sandy phases of the Cheyenne sandstone, as if they had been blown about by winds and accumulated in hollows. I have not encountered them in the clays, although the clays contain specimens of the foliage.

Whether or not *Sequoia condita* occurs at any other horizons or localities is problematic and can be determined only by the best of evidence, for, as I have already stated, the foliage is duplicated more or less closely by a variety of unrelated conifers. In particular the Upper Cretaceous conifer known as *Widdringtonites subtilis*, a form that I have not mentioned above, has foliage very like the more slender twigs of *Sequoia condita*, and in the absence of cones I doubt if the two could be distinguished. However, a single specimen of *Widdringtonites subtilis* found in the Tuscaloosa formation of Alabama had small four-valved cones entirely unlike those of *Sequoia condita*.

The Cheyenne sandstone localities are as follows: Cones and foliage, black hills near Belvidere (773); 1½ miles northwest of Belvidere (2218); Champion (Wildcat) Draw, three-fourths mile south of Belvidere (2222); near

Medicine Lodge Creek, 2 miles west of Belvidere (2224); left bank of middle branch of Champion (Wildcat) Draw, half a mile south of Belvidere (2224); right bank of same draw (2231); Osage Rock, near Belvidere (7406). Foliage only, Stokes Hill, 100 yards south of National Corral (2219); "Lanphier shales" in Champion (Wildcat) Draw, three-fourths mile south of Belvidere (2223); "Lanphier shales" in a draw 1 mile southwest of Belvidere (2225); hills between Spring Creek and Soldier, 4 miles northeast of Belvidere (2227); Champion (Wildcat) Draw, right (east) branch, half a mile south of Belvidere, in "Lanphier shales" (2228); first draw west of Champion (Wildcat) Draw, half a mile south of Belvidere (2233).

Family ABIETINEACEAE.

Genus ABIETITES Hisinger.

Abietites longifolius (Fontaine) Berry.

Plate XLVII, figure 3.

Abietites longifolius (Fontaine) Berry, U. S. Nat. Mus. Proc., vol. 40, p. 315, 1911; Maryland Geol. Survey, Lower Cretaceous, p. 407, pl. 67, fig. 7, 1911.

Leptostrobus longifolius Fontaine, U. S. Geol. Survey Mon. 15, p. 228, pl. 101, fig. 2; pl. 102, figs. 1-4; pl. 103, figs. 6-12; pl. 104, fig. 6, 1890; in Ward, U. S. Geol. Survey Nineteenth Ann. Rept., pt. 2, p. 671, pl. 163, fig. 15; pl. 165, fig. 3, 1899; U. S. Geol. Survey Mon. 48, pp. 281, 481, 482, 491, 506, 528, 557, pl. 110, fig. 11, pl. 116, fig. 1, 1906.

Leaves narrow, needlelike, 10 to 15 centimeters in length, aggregated in bundles. Bundles apparently borne on short shoots, with many leaves in each bundle. No satisfactory venation can be made out. Fontaine described a number of veins in these forms, but as nearly as can be determined these are simply folds due to compression or the angles of the leaf.

This species has a considerable geologic as well as geographic range, having been recorded from the Kootenai formation of British Columbia, the Fuson formation of the Black Hills, and the Potomac group in Maryland and Virginia. In the Potomac group it is of frequent occurrence and individually abundant, being found in the oldest as well as the youngest beds, but much more commonly in the latter. The remains are always poorly preserved and were evidently much macerated before fossilization. They are closely comparable with *Pinites solmsi* Seward, of the Wealden, and with *Pinus peterseni* Heer, from the Kome

beds of Greenland. They appear to be identical with specimens from the Atane beds of Greenland which Heer²⁴ described as *Pinus vaginalis*. I have not, however, included the latter in the foregoing synonymy, as it is an earlier name and would involve changing the well-known and highly characteristic name *longifolius*.

These remains are very common in the Cheyenne sandstone. Similar forms under different specific names are common and wide-ranging at Lower and Upper Cretaceous horizons in North America, Europe, and Asia.

The Cheyenne sandstone localities are black hills near Belvidere (773); 1½ miles northwest of Belvidere (2218); Thompson Creek near the flume, 2 miles northwest of Belvidere (2221); Champion (Wildcat) Draw, three-fourths mile south of Belvidere (2222); 1 mile southwest of Belvidere (2225); left bank of middle branch of Champion Draw, half a mile south of Belvidere (2229); and right bank of same branch (2231).

***Abietites ernestinae* Lesquereux.**

Abietites ernestinae Lesquereux, U. S. Geol. Survey Terr. Rept., vol. 6, p. 49, pl. 1, fig. 7, 1874.

Pterophyllum haydenii Lesquereux (part), Am. Jour. Sci., 2d ser., vol. 46, p. 91, 1868.

Lesquereux characterized this species as follows:

Cone oblong, abruptly narrowed to a short pedicel, scales broad, truncate, appressed, and imbricated in spiral.

This diagnosis obviously has nothing that would serve to set it apart from what might be written of dozens of fossil cone fragments of diverse relationships. The species was described from fragments collected near Decatur, Nebr., and similar cone fragments are present in the Cheyenne sandstone. They are not to be distinguished from other so-called species which I have referred to the genus *Abietites* of Hisinger.²⁵

This genus is a convenient and useful repository for fossils, both strobilar or foliar, whose real or fancied affinities are with the modern Abietinaceae. These range in age from the Keuper to the Pliocene, though the bulk came from the Cretaceous, and they comprise obscure impressions of foliage and cones, none of which have any real biologic value or present any

definite clue to their true relationship. Fontaine has included in this genus fossils from the Triassic of North Carolina and various indefinite remains from the Trinity group of Texas, the Shasta series of California, the Lakota sandstone of the Black Hills, and the Potomac group of Maryland and Virginia. The Potomac fossils he segregated into four species, all of which were based on obscure cone impressions and none of which possess much specific value. When it is remembered what diverse appearances may be assumed by a single species of cone, irrespective of individual variation, as a result of different stages of maceration before preservation, of differences in the matrix, and of differences in the direction and force of compression, it seems very probable that such forms can never be discussed satisfactorily.

Similar forms from the English Wealden and later Cretaceous are described by Carruthers, Gardner, Seward, and others and referred to the comprehensive genus *Pinites* of Endlicher (1847). They are in all probability congeneric if not specifically identical with American forms referred to *Abietites*, and that name is preferable, as *Pinites* Endlicher is antedated by *Pinites* Witham, which was proposed for very different objects.

Abietites cones are also common in the French and Belgian Cretaceous and have usually been referred to the genus *Pinus*, although there is slight warrant for such a procedure.

Abietites cones are rare in the Cheyenne sandstone, being known only from Osage Rock, at Belvidere, in the "Stokes sandstone" below the so-called Champion shell bed at the base of the Kiowa shale (2232).

Genus CUPRESSINOXYLON Goepfert.

***Cupressinoxylon cheyennense* Penhallow.**

Cupressinoxylon cheyennense Penhallow, Roy. Soc. Canada Trans., 2d ser., vol. 6, sec. 4, p. 76, 1900 [1901]; Manual of North American gymnosperms, p. 238, 1907.

This species was described as coming from the Cheyenne sandstone east of Stokes Hill, on the Kiowa-Baker County line, and was collected by Prosser.

There is nothing to be added to the original description of this species, which was unillustrated. Nor is it worth while to quote that description, for it is very doubtful if the form could be recognized again, even by the author,

²⁴ Heer, Oswald, Flora fossilis arctica, vol. 3, Abt. 2, p. 103, pl. 27, fig. 15b, 1874.

²⁵ Hisinger, W., Lethaea succica, p. 110, 1837.

short of comparison with the type sections. There is some doubt as to whether it came from the Cheyenne sandstone. I include it merely for the sake of completeness. In the case of *Araucarioxylon prosseri*, which Penhallow²⁶ recorded from this region, the data are so entirely uncertain that I omit any further reference to it.

Cupressinoxylon cheyennense is of some interest, as Penhallow definitely remarks upon the presence of growth rings, which is thus in accord with my supposition that the region had an arid climate and seasonal rainfall.

Phylum ANGIOSPERMOPHYTA.

Class MONOCOTYLEDONAE.

Order POALES.

Genus ARUNDO Linné.

***Arundo groenlandica* Heer?**

Arundo groenlandica Heer, Flora fossilis arctica, vol. 3. Abt. 2, p. 104, pl. 28, figs. 8-11, 1874; vol. 6, Abt. 2, p. 57, pl. 17, fig. 10, 1882; vol. 7, p. 18, pl. 54, figs. 1-3, 1883.

Brozzi, Soc. ital. sci. nat. Atti, vol. 31, p. 403, pl. 6, fig. 5, 1888; Soc. geol. ital. Boll., vol. 10, p. 376, pl. 16, fig. 3, 1891.

Berry, U. S. Geol. Survey Prof. Paper 84, p. 28, pl. 4, fig. 7, 1914.

Striated culms and fragments of long, linear pointed leaves, 2 to 3 centimeters in width. Veins numerous, fine, and parallel.

This identification is queried because of the general lack of individuality in remains of this sort. They include the specimens from Belvidere that Ward referred to as bamboo-like stems in his discussion of *Feistmantelia*.

The species was described by Heer from material found in both the Atane and Patoot beds of western Greenland. It was subsequently recorded by me from the Middendorf arkose member of the Black Creek formation in South Carolina and by Bozzi from the Emscherian of Italy. Little reliance can be placed upon records of remains of this sort, however, which also resemble in a general way the somewhat earlier forms referred by Schenk and others to *Eolirion*.

The Cheyenne sandstone localities are Champion (Wildecot) Draw, shales three-quarters of a mile south of Belvidere (222); hills between Spring Creek and Soldier, 4 miles northeast of

Belvidere (2227); and Champion (Wildecot) Draw, right (east) bank half a mile south of Belvidere ("Lanphier shales," 2228).

Class DICOTYLEDONAE.

Order SAPINDALES.

Family SAPINDACEAE.

Genus SAPINDOPSIS Fontaine.

***Sapindopsis variabilis* Fontaine.**

Plate LV, figures 2-4.

Sapindopsis variabilis Fontaine, U. S. Geol. Survey Mon. 15, p. 298, pl. 151, fig. 1; pl. 152, figs. 1, 4; pl. 153, fig. 3; pl. 154, figs. 2-4; pl. 155, figs. 2-5, 1890; in Ward, U. S. Geol. Survey Nineteenth Ann. Rept., pt. 2, p. 690, pl. 169, fig. 9, 1899; U. S. Geol. Survey Mon. 48, pp. 481, 482, 489, 532, pl. 114, fig. 2, 1906. Berry, U. S. Nat. Mus. Proc., vol. 38, p. 641, 1910; Maryland Geol. Survey, Lower Cretaceous, p. 469, pls. 83, 84, 85, 1911.

Sapindopsis parvifolia Fontaine, U. S. Geol. Survey Mon. 15, p. 300, pl. 154, fig. 6, 1890.

Eucalyptus rosiliriana Ward, U. S. Geol. Survey Mon. 48, p. 530, pl. 113, figs. 9, 10, 1906.

Ficus myricoides Ward, idem, p. 531, pl. 112, fig. 12, 1906.

Rogersia angustifolia Fontaine, in Ward, idem, pp. 491, 510 (not p. 521), 1906.

Leaves odd-pinnate, in some specimens even-pinnate, with three pairs of lateral leaflets, which may be opposite, although usually there is a tendency toward a subopposite arrangement, markedly so in several specimens. Leaflets normally lanceolate, individuals of the same leaf about of a size, usually markedly decurrent, but variable in this respect. The proximal leaflets are always less decurrent than the pair next above, and some even have short petioles. The upper leaflets are remarkably variable; some have an abnormal decurrent wing which joins the inner lamina of the next lower pair of leaflets; in others the rachis entirely lacks a wing. The leaf may be terminated abruptly by a pair of leaflets variously coalesced, or the three apical leaflets may be variously united, their laminae may be almost symmetrical or markedly inequilateral, their margins showing a tendency toward undulation, and rarely a leaflet is divided into a basal and an apical part by a sharp constriction on one side near the middle of the blade. The specimens range in size from the small forms upon which Fontaine founded his species *S. parvifolia* and which are 1.6 centimeters long and 0.4 centimeter wide to forms which approach *S. magnifolia* in size and are 10 centi-

²⁶ Penhallow, D. P., Roy. Soc. Canada Trans., 2d ser., vol. 6, sec. 4, p. 77, 1901.

meters long and 1.5 centimeters wide. The average dimensions of a large number of specimens, however, are 6 to 7 centimeters long by 1 to 1.3 centimeters wide.

Leaves thick, with smooth surface. Rachis and midrib stout. Venation more prominent than in the other species but still very faint, with the exception of the secondaries, which though fine are more conspicuous than in the other species. Secondaries forming a wide angle with the midrib, nearly straight for two-thirds of the distance to the margin, where they bend sharply upward and join the secondary next above by a slightly curved arch. As the secondaries are numerous and almost uniformly spaced the venation resembles that of a *Eucalyptus* except that the marginal hem is much broader than in that genus. In fact some of the detached leaflets were determined by Ward as forms of *Eucalyptus*, as also was some of the Virginia material of this species.

This species is exceedingly abundant at many localities in the Patapsco formation in Maryland and Virginia and is by far the most characteristic species of that formation, although it has not been detected at certain other undoubted Patapsco horizons. Not especially characteristic material is abundant along Oak Creek, Wyo., in beds that have been referred to the Fuson formation. This species was also suggested by Cockerell²⁷ for some leaves from an unknown geologic horizon in southwestern Colorado. I have since examined this material, which is very inconclusive, in my opinion. Cockerell infers that *Sapindopsis* may be related to *Guctum*, but I cannot see any warrant for such a supposition.

This species is an exceedingly variable form in all its details, and as during maceration the most variable apical portion is the last to be destroyed, this variability is emphasized in fragmentary material such as that usually found. When well preserved it furnishes most striking specimens, as may be seen from the specimens reproduced photographically in Plate LV (figs. 2-4). In life its rigid pinnate leaves and strict appearance must have made it a very striking member of the Cheyenne flora.

The Cheyenne sandstone occurrences of *Sapindopsis variabilis* are Osage Rock at Bel-

videre (2217, 2232); Stokes Hill (2220); Thompson Creek near the flume, 2 miles northwest of Belvidere (2221); Champion (Wilcat) Draw, three-fourths mile south of Belvidere (2222); Champion (Wilcat) Draw, right (east) branch, in "Lanphier shale," half a mile south of Belvidere (2224, 2228, 2231); in shale in a draw 1 mile southwest of Belvidere (2225); left bank of middle branch of Champion (Wilcat) Draw (2229); shales in draws north of Belvidere (2230); first draw west of Champion (Wilcat) Draw (2233).

***Sapindopsis magnifolia* Fontaine.**

Plate LV, figure 5; Plate LVI, Plate LVII, figure 2; Plate LIX, figure 3.

Sapindopsis magnifolia Fontaine, U. S. Geol. Survey Mon. 15, p. 297, pl. 151, figs. 2, 3; pl. 152, figs. 2, 3; pl. 153, fig. 2; pl. 154, figs. 1, 5; pl. 155, fig. 6, 1890; in Ward, U. S. Geol. Survey Mon. 48, pp. 481, 482, 528, 1906.

Berry, U. S. Nat. Mus. Proc., vol. 38, p. 642, 1910; Maryland Geol. Survey, Lower Cretaceous, p. 471, pl. 86; pl. 87, fig. 1; pl. 88, 1911.

Aralia dubia Fontaine, U. S. Geol. Survey Mon. 15, p. 314, pl. 157, figs. 1, 7, 1890.

Sapindopsis obtusidolia Fontaine, idem, p. 301, pl. 156, fig. 13; pl. 159, figs. 3-6.

Ficophyllum eucalyptoides Fontaine, idem, p. 294, pl. 164, figs. 1, 2; in Ward, U. S. Geol. Survey Mon. 48, p. 489, 1906.

Sapindopsis tenuinervis Fontaine, U. S. Geol. Survey Mon. 15, p. 301, pl. 153, fig. 1, 1890; in Ward, U. S. Geol. Survey Mon. 48, pp. 489, 528, 1906.

Rhus addeni Lesquereux, U. S. Geol. Survey Mon. 17 (Flora of the Dakota group), p. 151, pl. 57, fig. 2, 1892.

Knowlton, in Hill, Am. Jour. Sci., 3d ser., vol. 50, p. 213, 1895.

Leaves commonly odd-pinnate, although a few even-pinnate forms occur, of considerable size but somewhat variable. Leaflets three pairs, comparatively large, lanceolate, tapering almost equally toward apex and base, the base inequilateral except in terminal leaflets, pointed, often lacking apical portions, length increasing proximad, averaging about 10 centimeters, longest seen 14 centimeters (estimated), shortest 5 centimeters, width varying from 1.1 to 3.2 centimeters, inequilateral, as the outer half of the lamina is broader than the inner half and is markedly decurrent. This feature is least emphasized in the basal leaves, which may even have a considerable petiole, but becomes increasingly pronounced distad, the terminal leaflets often forming a bilobate or trilobate

²⁷ Cockerell, T. D. A., Washington Acad. Sci. Jour., vol. 6, p. 110, 1916.

whole with the outer margins broadly decurrent and joining the lamina of the leaflet next below at the point of junction of its inner margin with the rachis. Certain specimens show all the leaflets petiolate, a feature largely emphasized in a specimen from Stump Neck, Md., figured by me in 1911, showing three terminal leaflets with petioles 3 to 4 centimeters in length.

The leaflets in this species are much more commonly petiolate and lacking in the winged rachis than those in *S. variabilis*, in this particular closely resembling the leaflets of the modern *Matayba apetala*, in which the rachial wings are vestigial. Leaf substance thick and leathery; epidermis firm and glossy. Leaflets commonly subopposite, often markedly so, forming an acute angle with the rachis. Midribs stout and prominent below. Secondaries slender, seen only on the under surface of the leaflets and even there made out with difficulty, eight to ten pairs, branching from the midrib at a rather wide angle, especially in the central part of the leaf; the angle is more acute basally, curving upward ultimately to join a short branch of the secondary next above. Tertiaries fine, forming lax subrhombic areolae where visible.

This species is very common at certain localities in the Patapsco formation of Maryland and Virginia, although at other outcrops of this same formation it has not been detected.

The grounds for the separation of this species from *S. variabilis* are slight, as both are variable and the larger forms of *S. variabilis* are quite as large as the smaller forms of *S. magnifolia*. In the Patapsco formation the two species are found in association at all the localities where either occurs, and the smaller species is usually the more common, as if the larger species represented its occasional more robust forms. On the other hand, *S. magnifolia* has not been detected in the abundant remains referred to *S. variabilis* found at Oak Creek, Wyo., and there is commonly considerable disparity in size between the two. There are certain other differences which appear to be constant. These are the thicker, relatively longer leaflets of *S. magnifolia*, with less numerous and somewhat more

ascending secondaries, which are not connected distad by relatively flat arches.

The form recorded from the Cheyenne sandstone as *Rhus uddeni* Lesquereux belongs to this species, and I am convinced that this is true of Lesquereux's type material recorded from the Dakota sandstone and collected, according to J. A. Udden, "from the west slope of the Smoky Hill Buttes near Salemburg post office, Saline County, Kans." There are a number of other species described by Lesquereux in the "Flora of the Dakota group" which, although I do not feel justified in transferring them to *Sapindopsis*, are open to more or less suspicion. These are *Aralia masoni* Lesquereux,²⁸ collected 10 miles northeast of Delphos, Kans., which might represent the terminal part of a *Sapindopsis* leaf; *Laurus angusta* Heer,²⁹ which is a fragment from Ellsworth County, Kans., that in both form and venation agrees with *Sapindopsis*; *Leguminosites hymenophyllus* Lesquereux,³⁰ which is somewhat less similar to the known species of *Sapindopsis*; *Sapindus diversifolius* Lesquereux,³¹ from Ellsworth County, Kans., which is also less similar to the known species of *Sapindopsis*; and *Rhus powelliana* Lesquereux,³² obtained near Fort Harker, Kans., which differs from *Sapindopsis* in the subordinate lobing and small leaflets developed at the base of the proximal lateral leaflets, in these features resembling *Rhus*, but which is sufficiently like *Sapindopsis* to be open to more or less suspicion.

This species has been found in the Cheyenne sandstone at the black hills near Belvidere (773); Osage Rock, Belvidere (2217, 2232, 7406); Stokes Hill 100 yards south of National Corral (2219); Stokes Hill (2220); Thompson Creek near the flume, 2 miles northwest of Belvidere (2221); near Medicine Lodge Creek, 2 miles west of Belvidere (2224); left bank of middle branch of Champion (Wildcat) Draw, half a mile south of Belvidere (2229); shale along right branch of Champion (Wildcat) Draw (2228); and right bank of middle branch of Champion (Wildcat) Draw (2231).

²⁸ Lesquereux, Leo, U. S. Geol. Survey Mon. 17, p. 133, pl. 15, fig. 4, 1892.

²⁹ Idem, p. 93, pl. 16, fig. 7.

³⁰ Idem, p. 152, pl. 53, figs. 7-9.

³¹ Idem, p. 158, pl. 64, fig. 18.

³² Idem, p. 155, pl. 56, figs. 4, 5.

Sapindopsis brevifolia Fontaine.

Plate LV, figure 1; Plate LIX, figure 1.

Sapindopsis brevifolia Fontaine, U. S. Geol. Survey Mon. 15, p. 300, pl. 153, fig. 4; pl. 155, figs. 1, 7; pl. 163, fig. 3, 1890; in Ward, U. S. Geol. Survey Mon. 48, pp. 481, 482, 528, 1906.

Berry, U. S. Nat. Mus. Proc., vol. 38, p. 644; Maryland Geol. Survey, Lower Cretaceous, p. 473, pl. 87, figs. 2-5, 1911.

Leaves odd-pinnate, the terminal leaflet considerably larger than the lateral leaflets, of which but two pairs are known. These are opposite. Leaflets somewhat crowded so that their margins often overlap, with subacute tips, varying in length from 2 to 5 centimeters and in width from 0.8 to 1.6 centimeters, averaging about 3 centimeters long by 1.3 centimeters wide. Inequilateral toward the base and showing considerable variation in decurrence, even among the few specimens known; in some the rachis is conspicuously winged; in others the leaflets are all petioled, the whole having the aspect of some member of the Leguminosae. Midribs stout; secondaries ascending, camptodrome, seen with difficulty, as the leaf texture is coriaceous.

This is a poorly marked species of infrequent occurrence at the same localities where the other species of this genus occur and may simply represent a variant of *S. variabilis*; in fact, there is no reason for considering it to represent a distinct botanic species, and the name is retained temporarily simply as a geologic convenience, to be eventually dropped entirely.

The Cheyenne sandstone localities are 1½ miles northwest of Belvidere (2218), Thompson Creek near the flume, 2 miles northwest of Belvidere (2221); near Medicine Lodge Creek, 2 miles west of Belvidere (2224); left bank of middle branch of Champion (Wildcat) Draw half a mile south of Belvidere (2229); Osage Rock, Belvidere (2232).

Sapindopsis belviderensis Berry, n. sp.

Plates XLIX-LIV.

Leaves of variable size, pinnately compound, ranging in length (in the collected material) from 8 to 19 centimeters and in maximum width from 4.5 to 14 centimeters. These leaves are prevailing odd-pinnate, but a few are even-pinnate. In addition to the odd terminal leaflet generally present there are invariably

three pairs of lateral leaflets, which are generally opposite but sometimes subopposite. These usually decrease regularly in size from the distal to the proximal pair. In some specimens the terminal leaflet is equilateral, but all the other leaflets are inequilateral, often markedly so. All except the terminal leaflet are invariably sessile, the latter being separated from the distal laterals in some of the larger leaves by a considerable interval of rachis. Generally, however, the terminal and upper laterals are confluent in the rachial region to form what, if it were broken away from the balance of the leaf, would be considered to represent a palmately trilobate leaf such as is commonly referred to the genus *Aralia*. The sinuses may be rather broad, narrowly rounded, or pointed. The leaflets vary greatly in size, shape, and marginal characters but agree in being obtuse, generally abruptly and almost truncate mucronate pointed. The leaflets range in form from narrowly spatulate to broadly ovate or obovate. The margins are invariably toothed, but there is great variation in the amount and degree to which the teeth are developed. Proximally the margins are entire for a greater or less distance. Above this entire portion the teeth, which are remote and rather evenly spaced, may be small and serrate or very prominent and dentate. Were not all sorts of gradations present one might well doubt that they pertained to the same plants. The accompanying illustrations show these variations much better than they can be described. The lateral proximal margins of the terminal pair of leaflets, except in a single specimen, are decurrent on the rachis, extending downward to the point of insertion of the next lower pair of leaflets and often continuous with the distal margins of these. This rachial wing may be broad and triangular, a form which, as the terminal leaflets are the largest, gives the leaf a curious unsymmetrical or artificial appearance. In other specimens the wings are narrow and become reduced to mere marginal hems. In the middle pair of lateral leaflets the proximal margins are only slightly if at all decurrent, and generally they are not decurrent. No decurrence has been observed in the lower lateral leaflets, but they as well as the middle pair have the proximal side of the base fuller than the distal side, the former being generally rounded and the latter

incurved and sometimes disappearing some distance above the point of insertion. To judge by the lack of petiolules and the generally complete character of the material it does not appear that the leaflets were normally shed, and this is also indicated by the concrecence of the terminal leaflets. The leaves are coriaceous and appear to have been stiff and strict in habit. The rachis is stout and expanded proximad. The midribs are excessively stout and prominent on the lower surface. The secondaries are relatively thin, straight, and subparallel. They vary from camptodrome to craspedodrome. In the entire basal part of the leaf and sometimes in the apex they are camptodrome. In many specimens one secondary runs to each marginal tooth, although in other specimens the camptodrome habit is retained and a short branch enters the marginal tooth. All these features are indicated in the accompanying figures. The tertiary venation is usually obsolete, as the matrix is prevailingly coarse. Occasionally percurrent nervilles are seen. In specimens with broadly winged stripe the venation of the leaf is continued in these wings.

This handsome species is represented by a large amount of material, which is fortunate, as it would be almost impossible to correlate fragmentary material. It is clearly a representative of the genus *Sapindopsis* and would well merit the specific name of *variabilis* had that not already been used for the type of the genus, which came from the Patapsco formation of Maryland and Virginia.

In the Patapsco formation the genus *Sapindopsis* may be totally absent from a locality or present in the greatest abundance, and this is equally true of the Cheyenne sandstone of Kansas, indicating possibly a gregarious habit.

Various species of existing Sapindaceae show similarities to the present species in form, venation, and variation. All the previously described species of *Sapindopsis* had entire margins, and no trace of toothed margins has been found in the material from the Atlantic Coastal Plain. The existing genus *Matayba* Aublet, with which I originally compared *Sapindopsis*, has leaves with both entire and dentate margins, and the general features of *Sapindopsis* are shared by other tropical American genera of Sapindaceae. The genus *Matayba* comprises about two score existing

species and is closely related to *Cupania*, also exclusively American in the existing flora—in fact, all the genera of the tribe Cupanieae lomatorrhizae as segregated by Radlkofer are confined to the warmer regions of the Western Hemisphere.

Occurrence: Localities 2221, 2224, 2229, 2230, 7406, Medicine Lodge Creek, in draw 3 miles above Belvidere (Cheyenne sandstone No. 3 of Hill); collected by Ward and Vaughan, October 18, 1896 (unnumbered).

Order MALVALES.

Family STERCULIACEAE.

Genus STERCULIA Linné.

Sterculia towneri (Lesquereux) Berry.

Plate LVII, figure 1; Plate LX; Plate LXI, figure 1.

Aralia towneri Lesquereux, U. S. Geol. and Geog. Survey Terr. Bull., vol. 1, p. 394, 1875 [1876]; Ann. Rept. for 1874, p. 349, pl. 4, fig. 1, 1876; Cretaceous and Tertiary floras, p. 62, pl. 6, fig. 4, 1883; Flora of the Dakota group, p. 132, pl. 23, figs. 3, 4; pl. 31, fig. 1, 1892.

Sterculia drakei Cummings, Texas Geol. Survey Third Ann. Rept., p. 210, fig. 8, 1892.

Knowlton, in Hill, Am. Jour. Sci., 4th ser., vol. 1, p. 213, 1895.

Sterculia snowii Lesquereux, Flora of the Dakota group, p. 183, pl. 30, fig. 5; pl. 31, figs. 2, 3; pl. 32, figs. 1-4, 1892.

Hollick, U. S. Geol. Survey Mon. 50, p. 94, pl. 34, fig. 20, 1907.

Aralia towneri Hollick, New York Acad. Sci. Trans., vol. 16, p. 132, pl. 14, figs. 11, 12, 1897.

Berry, New York Bot. Garden Bull., vol. 3, p. 92, 1903.

I have long thought that the *Aralia towneri* and *Sterculia snowii* of Lesquereux represented a single species but have never had a chance to test this belief until I received the present collections from the Cheyenne sandstone, in which this is one of the most abundant forms. It shows considerable variation in size but obviously represents a single botanic species. Unfortunately the name *towneri* antedates *snowii* by some 15 years, so that the latter, which is much the better known of the two, becomes a synonym.

From the large amount of material now available the species may be described as follows:

Leaves of variable and often very large size, palmately two to seven lobed. The lobes are prevailingly conical and acuminate, occa-

sionally widening somewhat medianly and less acutely pointed, separated by generally open and rounded sinuses extending about halfway to the base. The angles that the lobes form with one another and the form of the sinuses vary with the number of lobes, as does also the character of the base, which ranges from truncate to decurrent. The median lobe is generally slightly wider than the others but may be smaller. The normal form is five lobed like the smaller of the two specimens from the Cheyenne sandstone here figured. The texture is so coriaceous that these leaves are well preserved in the scarcely consolidated wind-blown sand of the Cheyenne. The margins are entire. Length from 8 to 20 centimeters; maximum width from 6 to 24 centimeters. Petiole stout, usually broken away, 12 centimeters long in a medium-sized leaf figured by Lesquereux. Midrib stout, channeled, prominent on the under side of the leaf. An equally stout lateral primary diverges from the midrib, usually at its extreme base but occasionally slightly above. In the five-lobed forms this primary forks almost immediately into two subequal branches, which form the midveins of the respective lobes. In specimens having more than five lobes the additional ones are subordinate to the basal laterals, their midveins diverge at an acute angle from the midveins of these laterals, and their separating sinuses are less deep. The secondaries are thin and immersed in the leaf substance and are largely obsolete in the Cheyenne sandstone specimens; they are numerous, regularly spaced, subparallelled, and camptodrome in the lobes and in curved anastomosing loops in the body of the lamina.

This is an exceedingly well marked species and, like most *Sterculias*, both ancient and modern, shows the characteristic variability of the genus. It was described originally from material collected in the Dakota sandstone of Kansas and occurs in the Big Tucumcari Mountains of New Mexico in beds referred to the Dakota. It is recorded from the Magothy formation of Massachusetts and New Jersey. In the Cheyenne sandstone of Kansas it occurs at these localities: Black hills near Belvidere (773); Osage Rock, Belvidere (2217); Stokes

Hill, 100 yards south of the National Corral (2219); Thompson Creek near the flume, 2 miles northwest of Belvidere (2221); near Medicine Lodge Creek, 2 miles west of Belvidere (2224); left bank of middle branch of Champion (Wildcat) Draw, half a mile south of Belvidere (2229); draws north of Belvidere, in "Lanphier shales" (2230); Osage Rock, in "Stokes sandstone" (2232); Wildcat Draw (7405).

***Sterculia mucronata* Lesquereux.**

Sterculia mucronata Lesquereux, U. S. Geol. Survey Mon. 17 (Flora of the Dakota group), p. 182, pl. 30, figs. 1-4, 1892.

Leaves coriaceous, prevailingly small, palmately three to five lobed. Lobes entire, conical, separated by open rounded sinuses extending a variable distance, sometimes over halfway to the cuneate or truncate base. Petiole long and stout. Primaries three from the top of the petiole, stout and prominent. In the five-lobed forms subordinate branches from the lateral primaries furnish these with midveins. Secondaries thin, camptodrome. The tips of the lobes are prominently mucronate, and this feature, which suggested the specific name, is especially obvious in the Cheyenne sandstone specimens, where the mucros are 2 millimeters long and perhaps merit the designation cuspidate rather than mucronate.

The fact that these leaves are prevailingly small suggests that they probably represent small leaves of the associated *Sterculia towneri*, with which they agree in their main features—the mucronate tips of *S. mucronata* being the principal differential characteristic. The leaves originally described were obtained from the Dakota of Ellsworth County, Kans., and the species is known only from that region and the Cheyenne sandstone of southern Kansas, although there is a similar but distinct species, *Sterculia minima* Berry,³³ in the Magothy formation of New Jersey and Maryland. Two specimens were found in the Cheyenne sandstone near Medicine Lodge River, 2 miles west of Belvidere (2224).

³³ Berry, E. W., Maryland Geol. Survey, Upper Cretaceous, p. 857, pl. 80, figs. 1-3, 1916.

Order THYMELEALES.

Family LAURACEAE.

Genus SASSAFRAS Linné.

Sassafras mudgii Lesquereux.

Plate LXI, figure 3.

Sassafras mudgii Lesquereux, Am. Jour. Sci., 2d ser., vol. 46, p. 99, 1868; U. S. Geol. Survey Terr. Rept., vol. 6 (Cretaceous flora), p. 78, pl. 14, figs. 3, 4; pl. 30, fig. 7, 1874.

Ward, U. S. Geol. Survey Nineteenth Ann. Rept., pt. 2, p. 705, pl. 170, figs. 4, 5; pl. 171, fig. 1, 1899.

Berry, Bot. Gaz., vol. 34, p. 437, 1902.

?Kurtz, Mus. La Plata Rev., vol. 10, p. 53, 1902.

According to Newberry, this is merely a variety of his *Sassafras cretaceum*, but I fail to see any ground for this association except that it resembles somewhat the narrower-lobed leaves ascribed to that species. It is somewhat intermediate between these forms and the more typical *Sassafras acutilobum* but is much more like the modern leaf than either. Lesquereux's figures 3 and 4 of Plate XIV of the "Cretaceous flora" I consider to represent typical forms of this species. In the lengthening of the terminal lobe it approaches the modern *Sassafras*; and it shows no venation characters which are unlike the modern leaf, for although no marginal veins are discernible, they might have been present in the specimen illustrated in Lesquereux's figure 3, as they are in the identical form from the Cheyenne sandstone figured on the accompanying plate, and both specimens approach *Sassafras* in the relations of their secondary members in this region. If it is certain that the fruit has been found in the same strata, as Lesquereux³⁴ asserts, it only serves to substantiate the impression otherwise obtained that they are true *Sassafras* leaves. The lateral margins of both the base and the lobes are straighter and more ascending than in the existing *Sassafras*, and the margin shows a tendency to become wavy. Lesquereux's other figured specimen referred to this species differs in the size and direction of the lateral lobes, in the subbasal primaries, and in the acute tip; the venation also is somewhat dissimilar, the ascending margins bulge outward, and the base is not decurrent on the petiole, as it is most markedly in the specimens shown in his figures 3 and 4. It resembles somewhat the forms which New-

berry refers to *Sassafras acutilobum*. Ward's fragmentary leaves from the Black Hills are of doubtful identity. The more perfect specimen that he originally referred to *Lindera venusta* Lesquereux, which it resembles in outline, is a smaller leaf than *S. mudgii*, with subbasal primaries, considerable breadth of blade, and reduced terminal lobe.

Sassafras mudgii was based on material collected from the hills along Saline River in central Kansas. Up to the present time it has never been found elsewhere, except for the above-mentioned doubtful record by Ward from the supposed Dakota sandstone at Evans quarry, in South Dakota, and a still more doubtful South American record by Kurtz that may well be entirely ignored. It may be that the type was from the Mentor formation of central Kansas rather than from the true Dakota sandstone, as the species has never been found in collections from the Upper Cretaceous of the Atlantic Coastal Plain, but no outcrops of the Mentor formation are known as far north as Saline River.

The Cheyenne sandstone occurrences are Stokes Hill (2220) and near Medicine Lodge Creek, 2 miles west of Belvidere (2224).

Order UMBELLALES.

Family ARALIACEAE.

Genus ARALIA Linné.

Aralia ravniana Heer.

Plate LVIII; Plate LIX, figure 4.

Aralia ravniana Heer, Flora fossilis arctica, vol. 6, Abt. 2, p. 84, pl. 38, figs. 1, 2, 1882.

Berry, New York Bot. Garden Bull., vol. 3, p. 92, pl. 46, fig. 7; pl. 53, fig. 2; pl. 57, fig. 1, 1903; Torrey Bot. Club Bull., vol. 31, p. 79, 1904; vol. 37, p. 27, 1910; Maryland Geol. Survey, Upper Cretaceous, p. 876, pl. 82, fig. 4; pl. 83, figs. 1-4, 1916.

Aralia groenlandica Heer, idem, pl. 46, fig. 17.

?*Sterculia snowii* Hollick, New York Acad. Sci. Annals, vol. 11, p. 422, pl. 37, fig. 4, 1898.

This species was described by Heer from material collected in the Greenland Upper Cretaceous (Atane beds) and has been found by me in the Magothy formation of both New Jersey and Maryland. The fragments from Marthas Vineyard, Mass., and Tottenville, N. Y., identified as this species by Hollick,³⁵ are not this species, in my judgment. There is a

³⁴ Lesquereux, Leo, Flora of the Dakota group, p. 230, 1891 [1892].

³⁵ Hollick, Arthur, U. S. Geol. Survey Mon. 50, p. 99, pl. 37, figs. 1, 2, 1907.

great display of *Aralia*-like forms in the middle Cretaceous both of this country and of Europe, and these forms are especially abundant in the Dakota sandstone of the West. Comparisons with existing plants are not so satisfactory, although many tropical Araliaceae show suggestive resemblance. The Moraceae in the genus *Artocarpus* and its allies also show many similar features.

This most striking species of *Aralia*, because of its large size, has always been found in a fragmentary condition. Specimens showing all parts of the leaf have now been collected both from Maryland and from Kansas, and these conclusively confirm the restoration of this leaf made by me in 1903. They also confirm the supposition based on the venation of the New Jersey material, that instead of a broadly ovate median lobe, as Heer supposed, this middle lobe was sublobate by the greater or less development of a lateral lobe on each side, as shown in the accompanying illustrations. The species may be more fully defined in the light of all the material as follows: Leaves large, ranging from 16 to 21 centimeters in length and from 19 to 23 centimeters in maximum width, orbicular in general outline, deeply pinnately-lobate. Apex of the terminal and lateral lobes bluntly pointed. Base broadly cuneate. Margins entire. Texture subcoriaceous. Lobes usually seven, separated by relatively narrow ultimately rounded sinuses, comprising an ovate medium terminal lobe and two main lateral lobes on each side, the lower pair being more or less divided. In the Maryland material the auxiliary lobe on the lower side of each main lateral lobe is feebly developed. In the Greenland material it is at least half as large as the main lobe, and the separating sinus extends halfway to the base. Petiole stout, its full length unknown. Midrib very stout and prominent, straight. Lateral primaries two on each side, stout and prominent, the lower pair subopposite and suprabasilar, the upper pair in some specimens subopposite, more commonly separated by a wide interval. The lower primary may fork a short distance above its base, as it does in the Greenland material at an interval of only about 1 centimeter, or this fork may be at least 4 centimeters above the base, as in the Maryland material, the distance depending on the extent to which the auxiliary lobe is developed. The angle of divergence of

the primaries from the midrib is about 40° but varies from specimen to specimen; the basal pair is in general somewhat more divergent than the upper pair. The secondary and tertiary venation is usually obsolete. Some specimens show a few thin remote secondaries diverging from the primaries at angles of about 45° and sweeping upward in ascending camptodrome curves.

The Cheyenne sandstone material is not abundant. It comes from the left bank of the middle branch of Champion (Wildecut) Draw, half a mile south of Belvidere (2229) and the right bank of the same branch (2231).

Aralia newberryi Berry.

Aralia newberryi Berry, Torrey Bot. Club Bull., vol. 34, p. 201, pl. 15, fig. 1, 1907; New Jersey Geol. Survey Bull. 3, p. 197, 1911.

Aralia palmata Newberry, Flora of the Amboy clays, p. 117, pl. 39, figs. 6, 7; pl. 40, fig. 3, 1896 (not Lamarck). Berry, New York Bot. Garden Bull., vol. 3, p. 93, pl. 44, 1903; Torrey Bot. Club Bull., vol. 31, p. 79, pl. 4, fig. 12, 1904.

Aralia rotundiloba Hollick, New York Acad. Sci. Annals, vol. 11, p. 421, pl. 38, fig. 2, 1898.

Aralia polymorpha Newberry, Flora of the Amboy clays, p. 118, pl. 39, figs. 1-5, 1896.

Aralia sp. Hollick, New York State Mus. Ann. Rept., vol. 55, p. 155, 1903.

Leaves very variable in size and outline, palmately three to five lobed. Lobes conical, obtusely rounded. Sinuses open, shallow, rounded. Margins entire, somewhat undulate basally. Petiole long and stout. Midrib stout, more or less curved or flexuous. Primaries three to five, from the base, prominent, running to the tips of the lobes. Secondaries very slender, camptodrome. The middle lobe is usually longest and broadest, and the basal lateral lobes may be reduced to subordinate and but slightly marked parts of the main lateral lobes.

The relative development of the apical or basal lobes and the depth of the intervening sinuses greatly alter the appearance of these leaves. Some are symmetrical and others decidedly unsymmetrical; some are preeminently three lobed and sublobate and others are five lobed with additional incipient lobes. The variations are almost exactly comparable with the similar variations in the leaves of the modern *Sassafras*, *Sterculia*, and Araliaceae.

There seems to be no basis for maintaining the distinctions between the forms united in

the foregoing synonymy. The Cheyenne sandstone material is more like the irregular *A. polymorpha* than the more symmetrical *A. palmata* of Newberry's original material.

The species is common in the Raritan formation of New Jersey and survives in the overlying Magothy formation. In the Cheyenne sandstone it is represented by three specimens obtained near Medicine Lodge Creek, 2 miles west of Belvidere (2224).

Genus ARALIOPSOIDES Berry.

***Araliopsoides cretacea* (Newberry) Berry.**

Plate LXI, figure 2.

Araliopsoides cretacea (Newberry) Berry, Maryland Geol. Survey, Upper Cretaceous, p. 879, pl. 74, fig. 3; pl. 84, figs. 1, 2; pl. 85, figs. 1-5; pl. 88, figs. 1-3, 1916; Torrey Bot. Club Bull., vol. 38, p. 413, 1911

Sassafras (Araliopsis) cretaceum Newberry, New York Lyc. Nat. Hist. Annals, vol. 9, p. 14, 1868.

[Lesquereux], U. S. Geol. and Geog. Survey Terr., Illustrations of Cretaceous and Tertiary plants, vol. 6, figs. 1-4; U. S. Geol. Survey Terr. Rept., vol. 6 (Cretaceous flora), p. 80, pl. 11, figs. 1, 2; pl. 12, fig. 2, 1874; U. S. Geol. Survey Mon. 17, p. 102, 1892.

Newberry, U. S. Geol. Survey Mon. 35, p. 98, pl. 6, figs. 1-4; pl. 7, figs. 1-3; pl. 8, figs. 1, 2, 1898.

Hollick, U. S. Geol. Survey Mon. 50, p. 77, pl. 30, fig. 10, 1906.

Penhallow, Roy. Soc. Canada Trans., 3d ser., vol. 1, sec. 4, p. 310, 1907.

Berry, Torrey Bot. Club Bull., vol. 37, p. 22, 1910.

Leaves petiolate, decurrent at base, very smooth above, strongly nerved below, three lobed; lobes entire and acute. The nervation is all strongly defined; the central nerve straight or nearly so; the lateral primary nerve springing from it at an angle of 30°; secondary nerves regularly arched-till they approach the margin of the lobes, when they are abruptly curved and run together. From these the tertiary nerves are given off at a right angle, and from these the quaternary nerves spring at a similar angle, together forming a network of which the areoles are subquadrate.—Newberry, 1868.

Newberry includes under *Sassafras cretaceum* the various forms described by Lesquereux as *S. mudgii*, *S. subintegrifolium*, *S. integrifolium*, *S. obtusum*, *S. cretaceum dentatum*, *S. cretaceum obtusum*, *S. acutilobum*, *Cissites harkerianus*, and *C. salisburyae-folius*. Although this list shows the undoubted composite nature of *S. cretaceum*, it also shows that the extremes of leaf form above mentioned are so closely connected with the more typical leaf by a series of intermediate forms that the problem of where one species shall end and another begin is an extremely difficult one to solve.

I consider the leaf figured by Newberry on Plate VI, figure 1, of "Later extinct floras" (Mon. 35) to be the typical form of this species, thus agreeing with Newberry's original description and with his later opinion expressed in 1898. This type bears considerable resemblance to some modern *Sassafras* leaves. A slight widening of the terminal lobe of some of these in the basal region would give a leaf strikingly like *Araliopsoides cretacea*; or were the sinuses of the latter slightly deeper we would have the typical modern leaf. In its basal portion the leaf is like *Sassafras*, and the indications point to a similar venation in this region. The first pair of secondaries do not branch to form margins of the sinuses; the left one runs directly to the sinus, however, and may possibly have conformed to the margin and been effaced in the specimen; the right one is stronger and runs almost to the sinus, where it makes a sharp turn upward, continuing until it joins the next secondary. This feature is analogous to those in the modern leaf, which may indicate the mode of origin of this peculiar character. This leaf seems to form a central figure from which a series of forms grade in several directions, culminating in quite dissimilar leaves. Lesquereux's *Sassafras cretaceum* is a more planatoid leaf, with more acute tips, a tendency to become dentate, and the primaries inserted nearer the base. Closely allied to *S. cretaceum* is his *Sassafras (Araliopsis) mirabile*, which serves as a connecting link with his *Platanus recurvata*. From the *Sassafras cretaceum* of Lesquereux it is but a step to such a leaf as the one shown on Plate VIII, figure 2, of "Later extinct floras" and to the trilobed forms referred to *Cissites harkerianus*, and these in turn grade into the more cissoid forms of this species, such as those shown on Plate II, figure 3, of Lesquereux's "Cretaceous flora." The primaries are basal and of not much greater caliber than the regularly succeeding straight secondaries. It is but a step from this leaf to *Cissites heerii*, on the one hand, with its palmately five-pointed blade, and to such forms as *Cissites acuminatus* (Pl. V, fig. 4, "Cretaceous and Tertiary floras"), on the other; which in turn, by the elimination of the decreasing dentate points, gives us the leaf shown on Plate V, figure 3, "Cretaceous and Tertiary floras." In the second series of

leaves diverging from the typical *Sassafras cretaceum*, the form shown in Plate VIII, figure 1, of "Later extinct floras" is removed a slight distance by the shortening of the blade, the thickening of the primaries and secondaries, and the shortening and rounding of the lobes (*Sassafras obtusum*); while a smaller leaf would be its logical descendant; and from these leaves to those referred to the typical *Cissites salisburiaefolius* is but a step. In the third series of leaves diverging from the typical *Sassafras cretaceum* the leaf has its lobes much produced, narrow, and running to a sharp point, as in the beautiful leaf shown on Plate VII, figure 1, of "Later extinct floras," which, however, is still referred to *Sassafras cretaceum*. Lesquereux's *Sassafras acutilobum* does not differ greatly from the leaf just mentioned except in the direction of the lobes, which is a questionable specific character. From this leaf it is no great jump to those trilobed forms which are referred to *Aralia wellingtoniana*, the chief difference being in the margin. Thus we have an interrelated series connecting those leaves which seem to show affinity to *Sassafras* with those which suggest *Platanus*, on one hand, and with others which suggest *Cissites* and *Aralia*, on the other.

While it may be considered probable that biologically the forms mentioned in the foregoing paragraphs, as well as others not cited, represent the variations of a single species of Upper Cretaceous tree or at least represent the leaves of closely affiliated species, it seems best with reference to systematic and especially stratigraphic paleobotany that most of the differentiations instituted by Lesquereux be perpetuated. Consequently the present series is limited to the typical material as defined and illustrated by the original describer.

Falling within these limits are a number of occurrences in the true Dakota sandstone and the Raritan and Magothy formations of the Atlantic Coastal Plain. The Cheyenne sandstone has furnished four specimens obtained near Medicine Lodge River, 2 miles west of Belvidere (2224), and one specimen from the left bank of the middle branch of Champion (Wildecut) Draw, half a mile south of Belvidere (2229).

POSITION UNCERTAIN.

Genus **FEISTMANTELIA** Ward.

Feistmantelia oblonga Ward.

Plate XLVII, figures 4, 5.

Feistmantelia oblonga Ward, U. S. Geol. Survey Nineteenth Ann. Rept., pt. 2, p. 693, pl. 169, fig. 19, 1899.

In not proposing a specific name for the form of this genus found in the Cheyenne sandstone I emphasize the fact that the term *Feistmantelia* denotes merely a form of preservation and that the objects to which it is applied lack either stratigraphic or botanic value.

This genus and in fact the nominal species *Feistmantelia oblonga* were founded by Ward in 1899 for the reception of certain casts of obscure affinities, but evidently of a vegetable nature, from the Fuson formation of eastern Wyoming. No diagnosis was attempted, but an extended discussion was given of somewhat similar forms figured by previous authors from various geologic horizons. The American Cretaceous forms referred to this genus may be characterized as showing a rather close-set series of elliptical, fusiform, or cigar-shaped convex casts of concave cavities formed by the rhytidosis of various plant tissues. They vary considerably in size, from 0.6 to 2.5 centimeters in length by 0.35 to 1.0 centimeter in width, and are arranged in an irregular spiral, the irregularity being perhaps due to compression. They are thus overlapping or alternate in a horizontal direction and more or less linear in a vertical direction.

Somewhat similar remains occur at widely separated geologic horizons, and comparable objects with the markings inclined to be rhomboidal in form are not rare in the New Jersey Triassic deposits, where they are, according to Newberry,³⁶ the decorticated trunks of some conifer, possibly *Palissya*. Similar remains are figured by Schaubert³⁷ as trunks of *Voltzia coburgensis* and by Blanckenhorn³⁸ as trunks of *Voltzia heterophylla*.

³⁶ Newberry, J. S., U. S. Geol. Survey Mon. 14, p. 94, pl. 26, figs. 1, 2, 1888.

³⁷ Schaubert, Deutsch. geol. Gesell. Zeitschr., Band 4, p. 539, 1852. See Schenk, August, Palaeontographica, Band 11, p. 308, pl. 46, fig. 2, 1864.

³⁸ Blanckenhorn, Max, Palaeontographica, Band 32, p. 135, pl. 22, figs. 18-20, 1886.

Among the somewhat similar forms which Ward mentions are remains from Kukurbit, in Kach (Lias), described by Feistmantel³⁹ as "portions of a stem of a coniferous plant." Next in point of similarity are certain English and German Wealden remains regarded as parts of *Clathraria anomala*,⁴⁰ some of which are still referred by Seward⁴¹ to *Bucklandia anomala*, a later name for the same plant. The latter are undoubtedly medullary casts of cycadophyte trunks, a class of remains for which Saporta⁴² proposed the name *Cycadeomyelon*, describing one species from the infra-Lias of Hettange, near Metz (Moselle).⁴³ Remotely similar remains from the Triassic of York County, Pa., are described by Fontaine⁴⁴ as *Cycadeomyelon yorkense*, and the forms described by Newberry⁴⁵ are referred to it, although Seward⁴⁶ had shown that remains from abroad identical with these are to be interpreted as medullary casts of *Voltzia*. Similar remains were more recently discussed by Wills,⁴⁷ who refigures one of the original specimens of *Voltzia coburgensis*.⁴⁸ They are also practically identical in character, as Potonié⁴⁹ has shown, with casts of the medullary cavities of certain existing Araucarias, notably *Araucaria brasiliiana*. Other remains of this general sort, which, however, seem referable to the Cycadophyta, are *Omphalomela scabra* Germar,⁵⁰ renamed by Schimper⁵¹ *Clathraria? germari*, and *Cycadeoidea stillwelli* Ward.⁵² As Seward has pointed out, Williamson⁵³ figured very similar casts of the medullary cavity of *Stigmaria*, thus emphasizing the wide range in botanic affinity of objects of this kind.

³⁹ Feistmantel Ottokar, Fossil flora of the Gondwana system, vol. 2, pt. 1, p. 61, pl. 10, fig. 2, 1876.

⁴⁰ Stokes and Webb, Geol. Soc. London Trans., 2d ser., vol. 1, pl. 46, fig. 8; pl. 47, figs. 4b, 4c, 1824. See Schenk's figure of *Clathraria lycelli* Mantell, Palaeontographica, Band 19, p. 227, pl. 30, fig. 7, 1871.

⁴¹ Seward, A. C., Wealden flora, pt. 2, p. 123, 1895.

⁴² Saporta, Gaston de, Plantes jurassiques, tome 2, p. 331, 1875.

⁴³ Idem, p. 333, atlas, pl. 49, fig. 5.

⁴⁴ Fontaine, W. M., in Ward, L. F., U. S. Geol. Survey Twentieth Ann. Rept., pt. 2, p. 248, pl. 30, 1900.

⁴⁵ Newberry, J. S., op. cit.

⁴⁶ Seward, A. C., Geol. Mag., dec. 3, vol. 7, pp. 218-220, fig. 1, 1890.

⁴⁷ Wills, L. J., Geol. Assoc. Proc., vol. 21, pp. 292-294, 1910.

⁴⁸ Idem, pl. 17, fig. 6.

⁴⁹ Potonié, H., K. preuss. geol. Landesanst. Jahrb., 1887, pp. 311-331, pls. 12-13a.

⁵⁰ Germar, E. F., Palaeontographica, Band 1, p. 3, 1846.

⁵¹ Schimper, W. P., Paléontologie végétale, tome 3, p. 554, 1874.

⁵² Ward, L. F., U. S. Geol. Survey Twentieth Ann. Rept., pt. 2, p. 636, pl. 149, 1900.

⁵³ Williamson, W. C., A monograph on the morphology and histology of *Stigmaria ficoides*, pl. 13, figs. 64, 65, Palaeont. Soc., 1887.

Turning now to the Cretaceous remains to which the genus, if used at all, should be restricted (although Ward has the temerity to rename Feistmantel's Indian Liassic fossil *Feistmantelia fusiformis*), we may note that in addition to the type species from the Fuson formation, Fontaine⁵⁴ has described an additional species from the Patuxent formation at Cockpit Point, Va., which is really indistinguishable from the type species, and Ward⁵⁵ has mentioned the occurrence of similar objects from Kansas at a higher Cretaceous horizon. Still more recently Hollick and Jeffrey⁵⁶ have described comparable remains with structure preserved from the upper Raritan of Kreischer-ville, Staten Island, and have demonstrated their coniferous nature, naming their material *Pinus* sp.? Some of this material is said to have been found in organic connection with wood showing the characters of *Pitoxylon*. It is not altogether clear that the Lower Cretaceous species of *Feistmantelia* are of the same nature as that described by Hollick and Jeffrey, although these authors have furnished the presumption that they are all casts of the interstitial cavities of the periderm network of the bark, due to decay, in some conifer. That they should be referred to *Pinus*, even for individual specimens, seems unwise, and the genus *Feistmantelia* is here retained as a convenient form genus for remains of this sort, which may represent various modern coniferous genera.

Indistinguishable remains occur in the Tuscaloosa formation of Alabama, although I did not consider them of sufficient importance to include them in my paper on the Tuscaloosa flora.⁵⁷ They are also present at as recent a horizon as the upper part of the Black Creek formation in North Carolina. These also I did not consider of sufficient interest to include in my account of that flora, but I am including here a figure of a North Carolina specimen for comparison with one from the Cheyenne sandstone, to show that the latter is without stratigraphic value.

⁵⁴ Fontaine W. M., in Ward, L. F., U. S. Geol. Survey Mon. 48, p. 484, pl. 107, fig. 3, 1906.

⁵⁵ Ward, L. F., U. S. Geol. Survey Nineteenth Ann. Rept., pt. 2, p. 694, 1899.

⁵⁶ Hollick, Arthur, and Jeffrey, E. C., New York Bot. Garden Mem., vol. 3, p. 17, pl. 3, fig. 8; pl. 22, fig. 5, 1909.

⁵⁷ Berry, E. W., U. S. Geol. Survey Prof. Paper 112, 1919.

The Cheyenne material contained in the present collection comes from Champion (Wildcat) Draw, three-fourths mile south of Belvidere (2222), and hills between Spring Creek and Soldier, 4 miles northeast of Belvidere, where it is extremely abundant.

Genus **CARPOLITHUS** of authors.

Carpolithus belviderensis Berry, n. sp.

Plate XLI, figure 4.

This species is based on a single characteristic specimen, which is entirely distinct from anything previously described. It represents a large pyriform pedunculate pyxidium 1.8 centimeters in length and 13.5 millimeters in maximum diameter. The peduncle is curved

and stout, about 1 centimeter in length. The pyxidium is pointed proximad, widest and flatly rounded distad. The sides are distinctly fluted with twelve or thirteen rounded nodes separated by shallow rounded sinuses. The ribbing may indicate parietal placenta or a loculicidal habit, although the latter alternative appears to be negatived by the lid.

It is possible that this conspicuous and characteristic fruit may not have been a true pyxidium and shed its seeds by loosening of the lid, as in *Eucalyptus*, but that it was a capsule like that of *Papaver* and the small parietal seeds were discharged through openings beneath the so-called lid, which may represent a concrescent stigma. The specimen comes from Stokes Hill, northeast of Belvidere (2220).

PLATES XLVII-LXI.

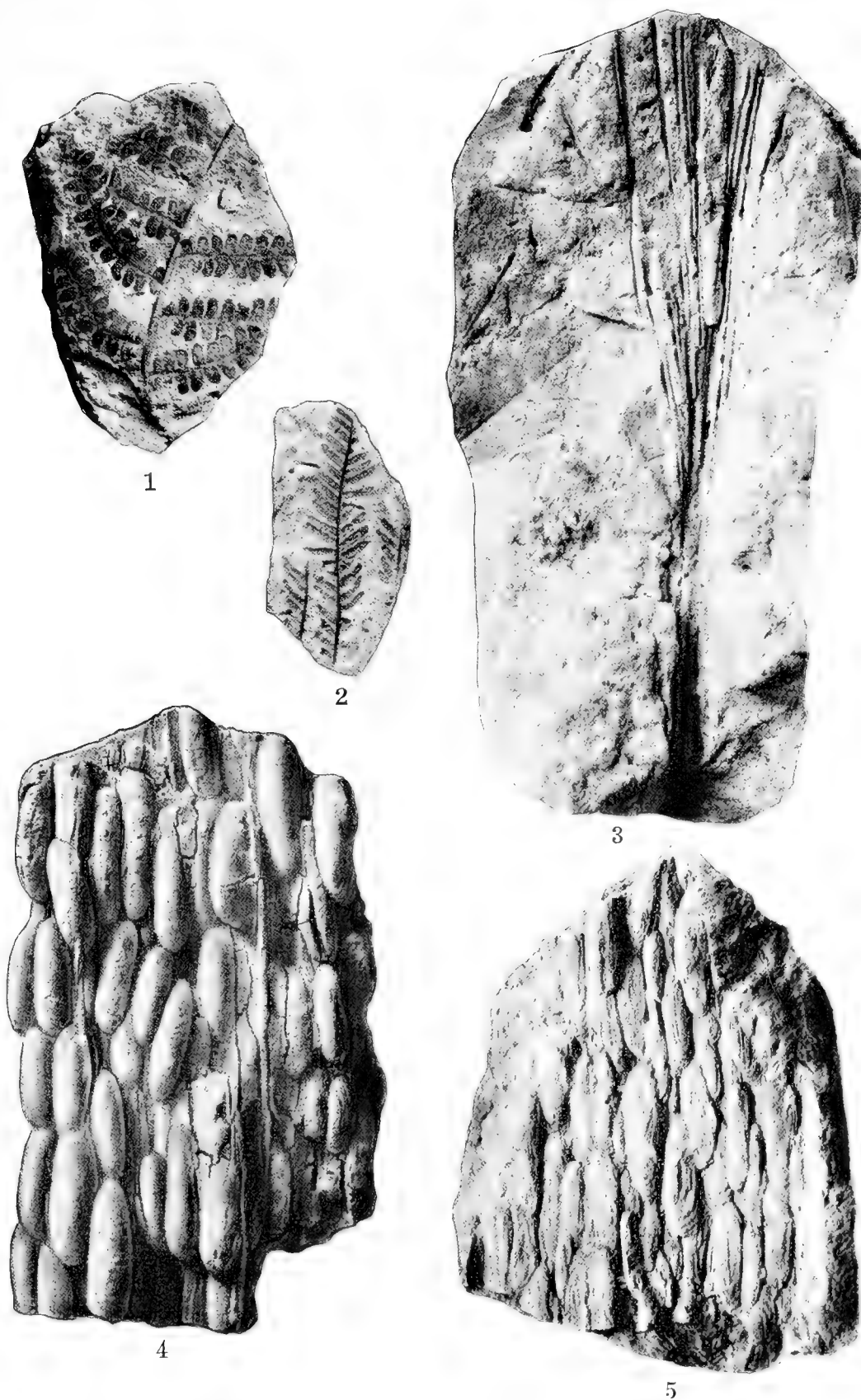

FOSSIL PLANTS FROM THE CHEYENNE SANDSTONE.

1, *Gleichenia nordenskioldi* Heer; 2, *Gleichenia* (?) *bohémica* (Corda) Berry; 3, *Abietites longifolius* (Fontaine) Berry; 4, 5, *Feistmantelia oblonga* Ward. All the specimens are from the Cheyenne sandstone near Belvidere, Kans., except that shown in figure 4, which is from the Black Creek formation of North Carolina.

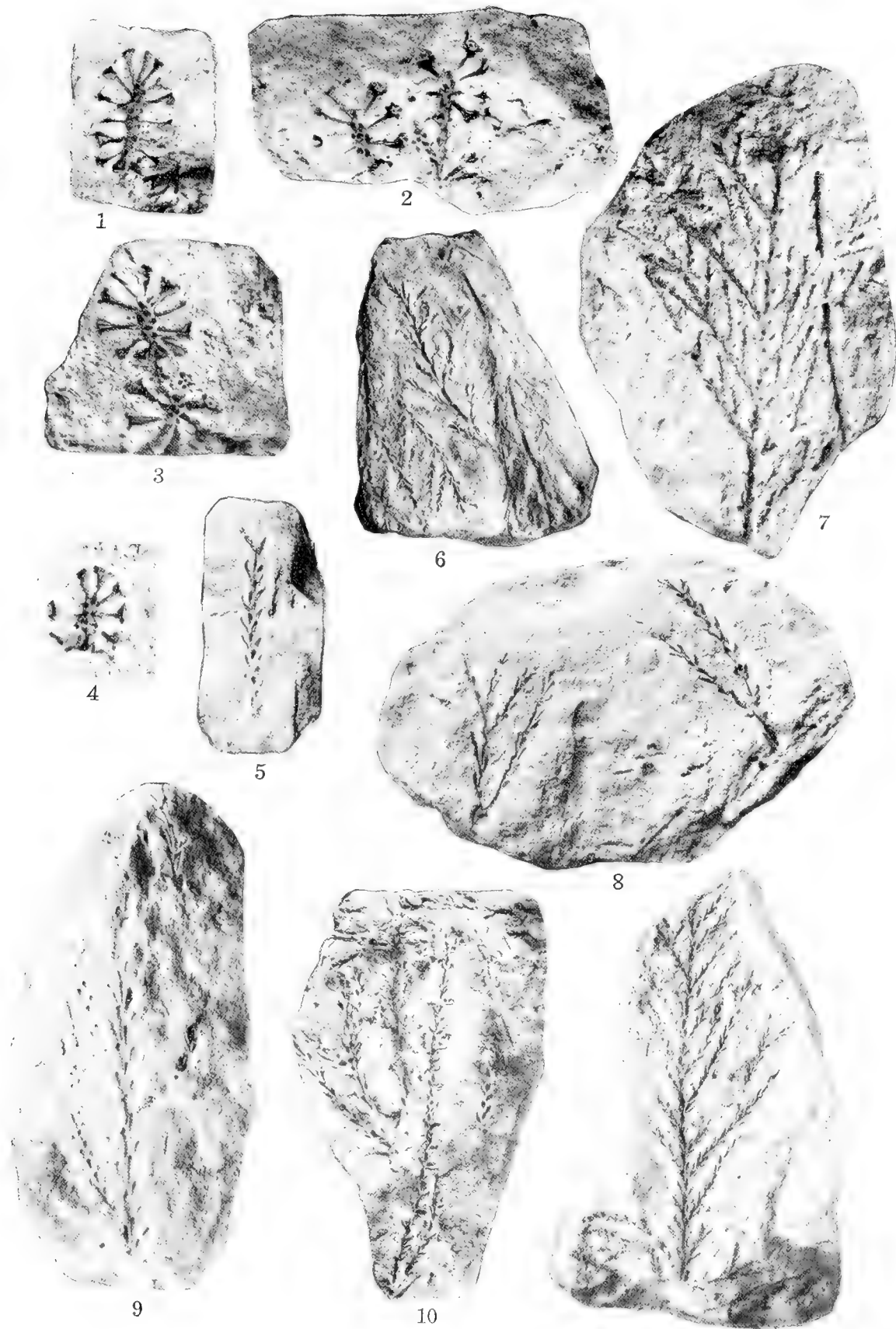

CONES AND FOLIAGE OF SEQUOIA CONDITA LESQUEREUX.

From Cheyenne sandstone at several localities near Belvidere, Kans.

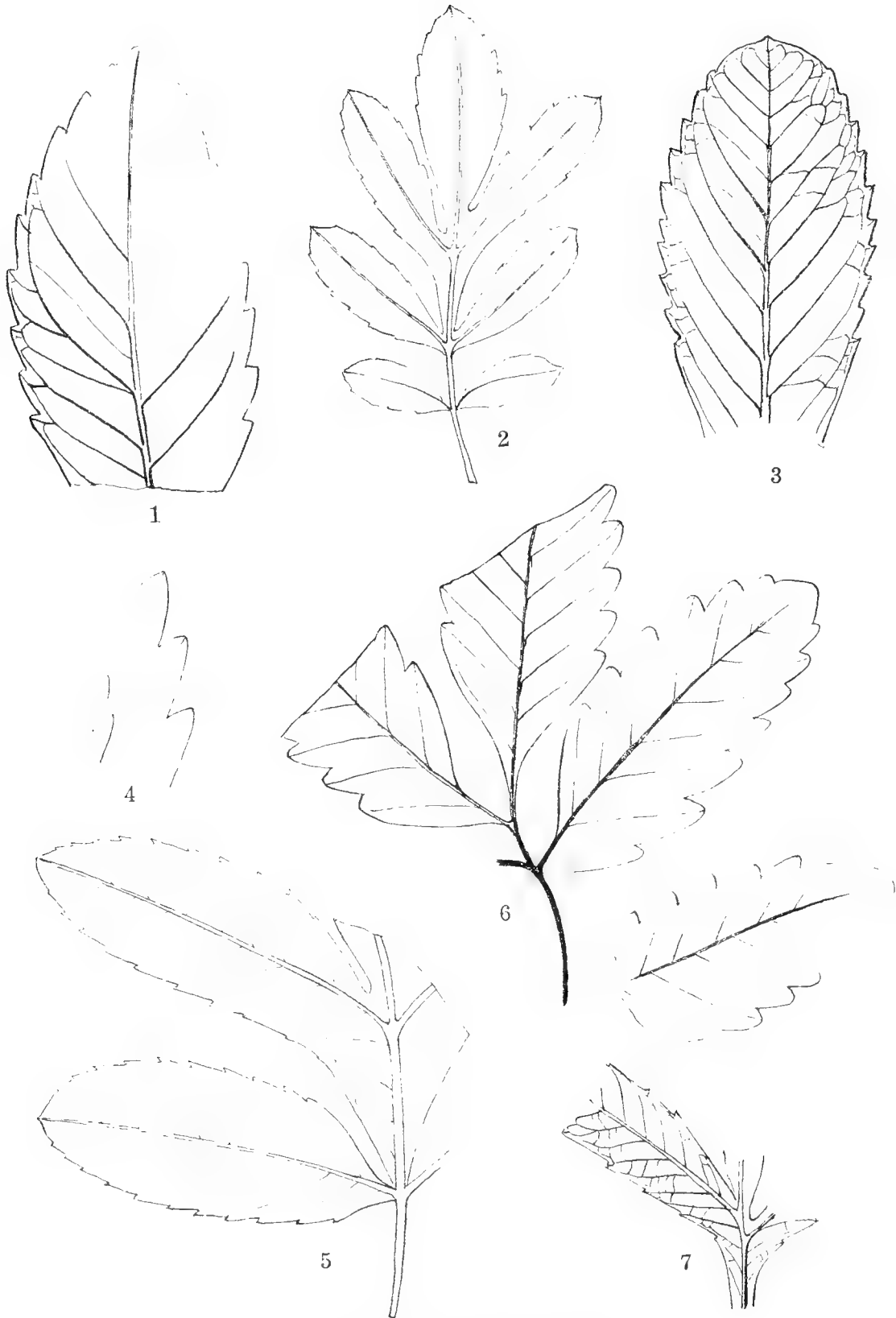

SAPINDOPSIS BELVIDERENSIS BERRY.

From Cheyenne sandstone near Belvidere, Kans.

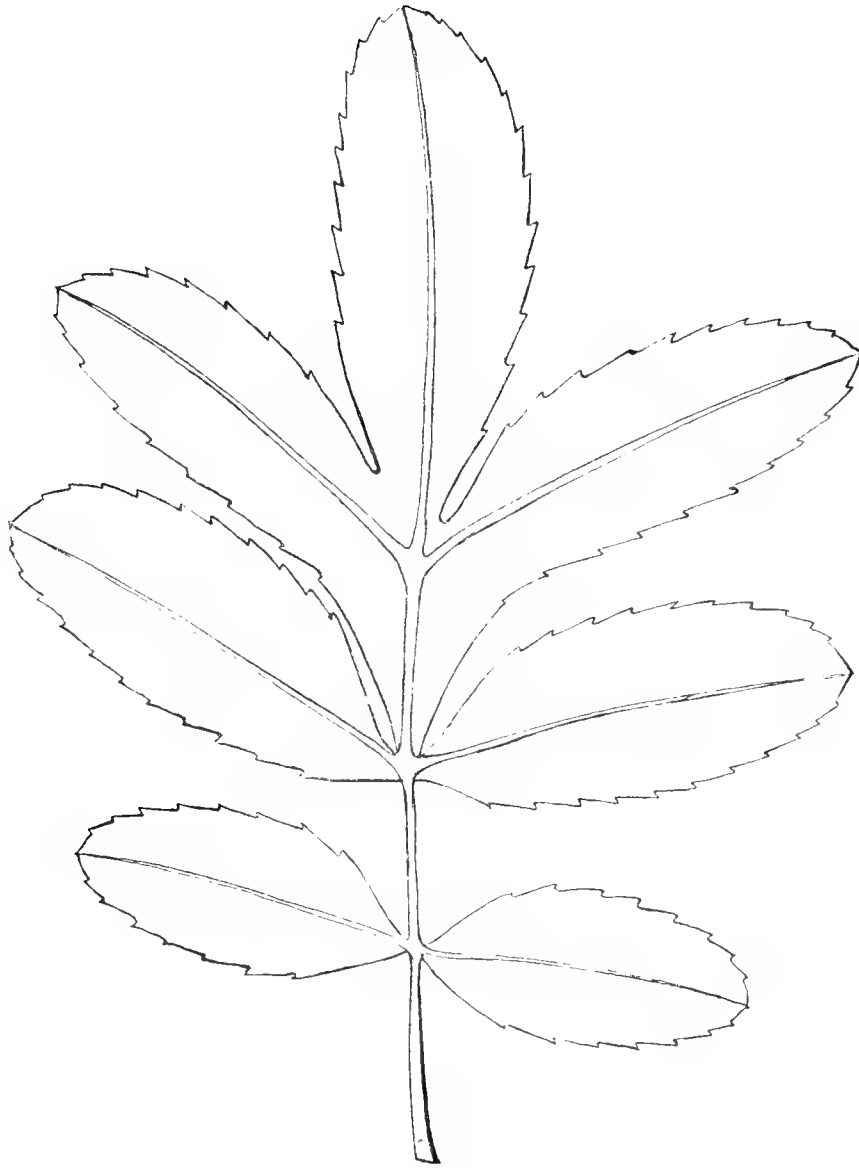

RESTORATION OF *SAPINDOPSIS BELMIDERENSIS* BERRY

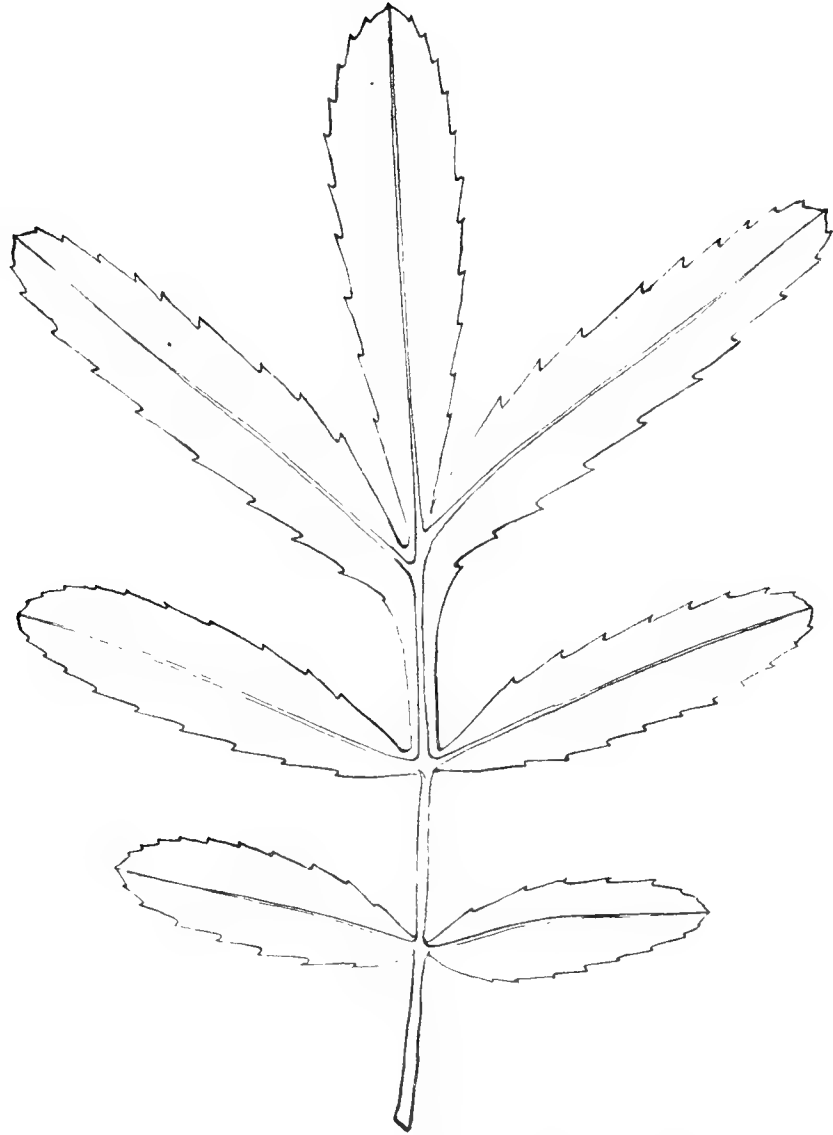

RESTORATION OF SAPINDOPSIS BELVIDERENSIS BERRY

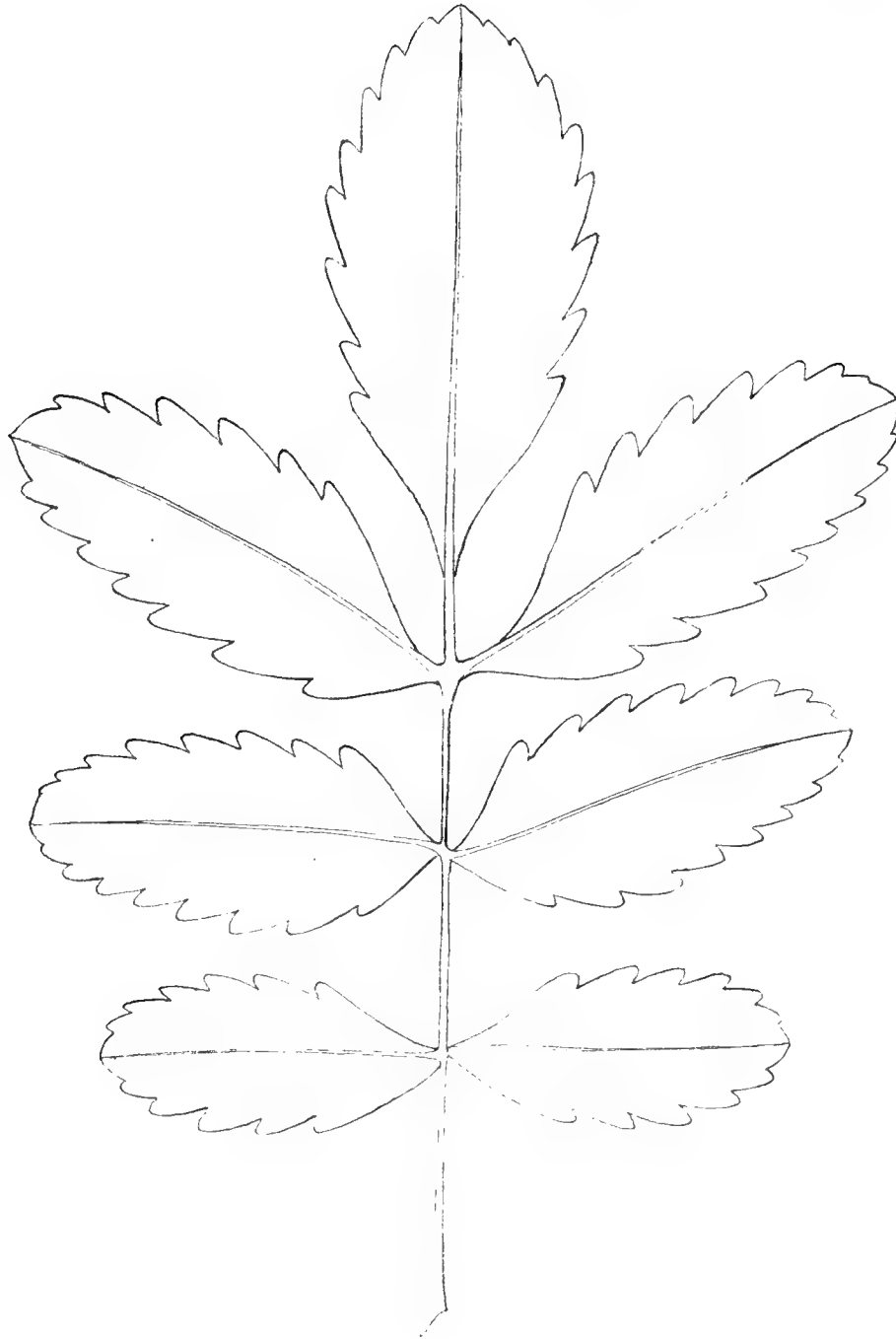

RESTORATION OF *SAPINDOPSIS BELVIDERENSIS* BERRY.

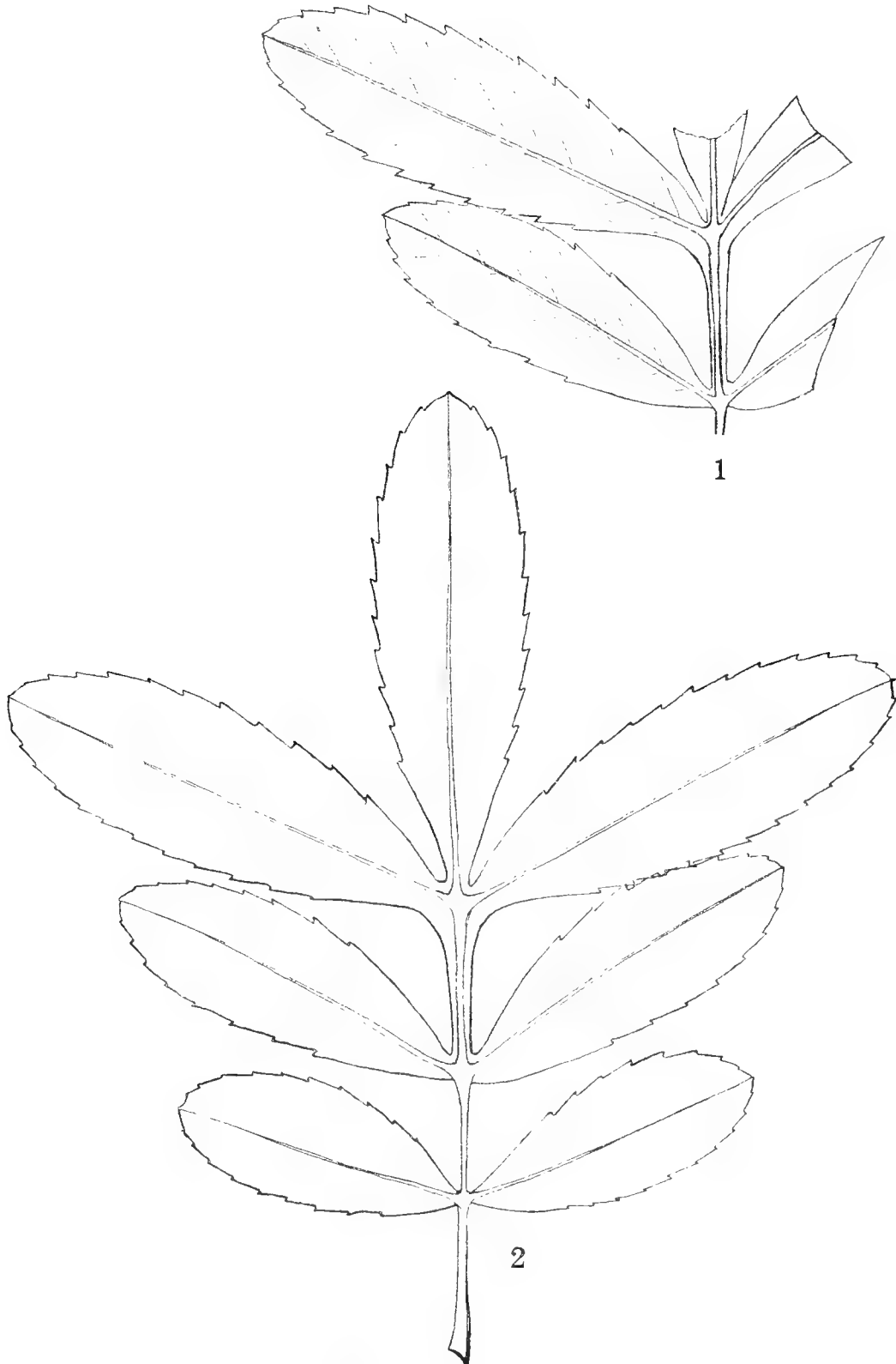

SAPINDOPSIS BELVIDERENSIS BERRY.

1, Specimen obtained near Belvidere, Kans.; 2, restoration of specimen shown in figure 1.

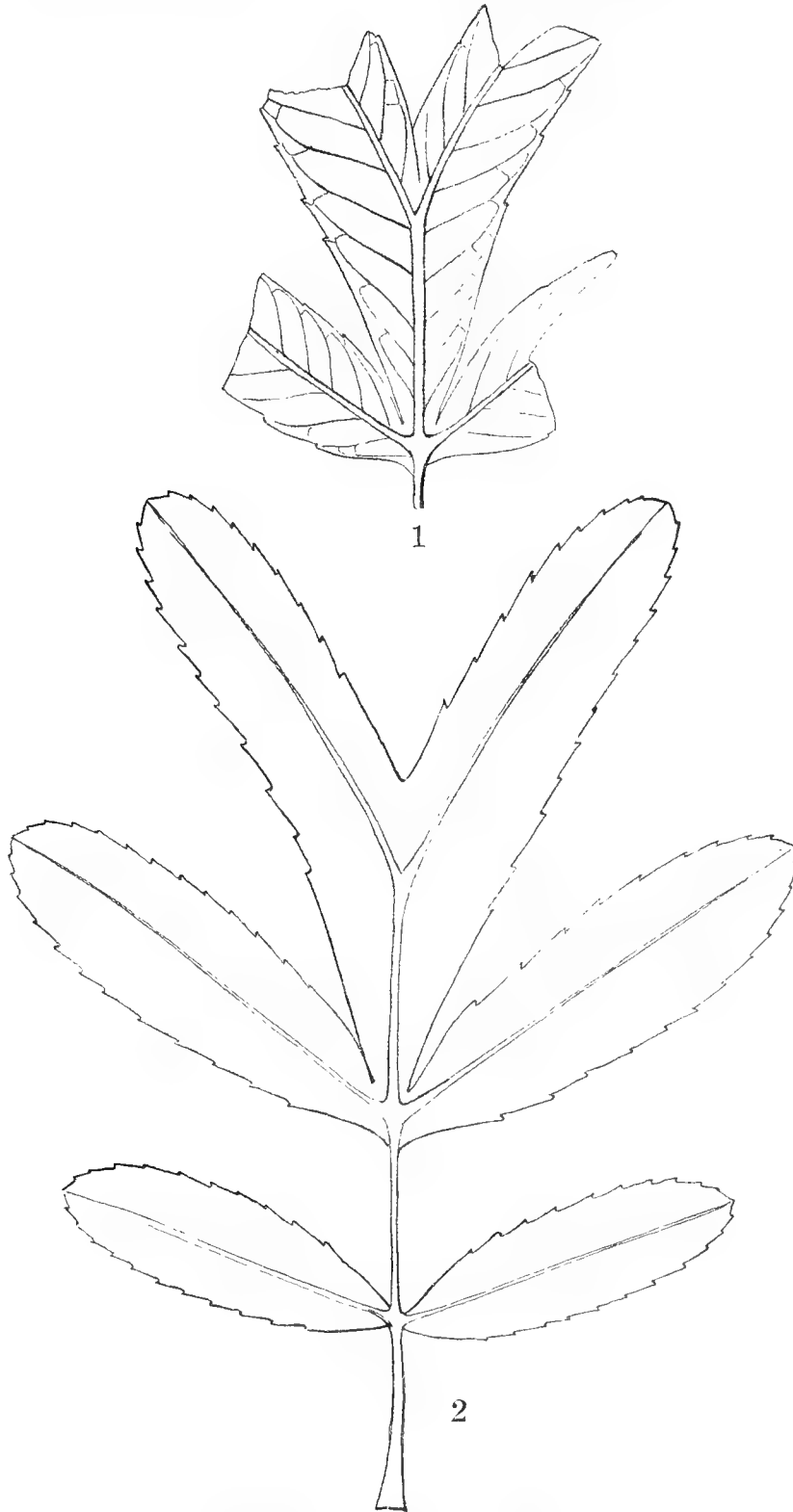

SAPINDOPSIS BELVIDERENSIS BERRY.

1, Specimen obtained near Belvidere, Kans.; 2, restoration of specimen shown in figure 1.



FOSSIL PLANTS FROM THE CHEYENNE SANDSTONE.

1, *Sapindopsis brevifolia* Fontaine; 2-4, *Sapindopsis variabilis* Fontaine; 5, *Sapindopsis magnifolia* Fontaine. All collected near Belvidere, Kans.

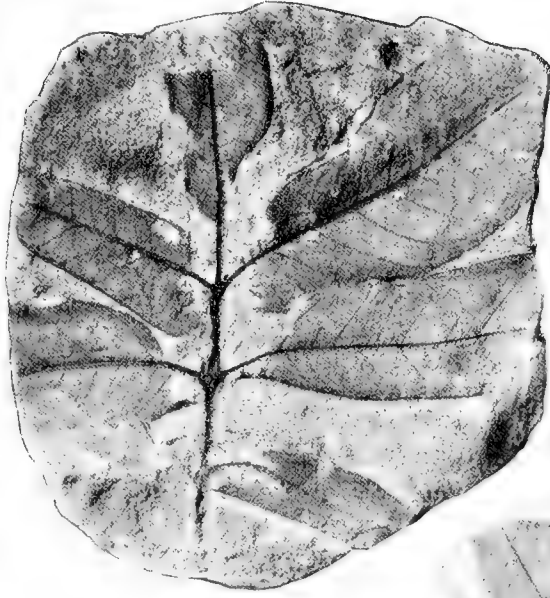

1



2



3

SAPINDOPSIS MAGNIFOLIA FONTAINE.
From Cheyenne sandstone near Belvidere, Kans



1

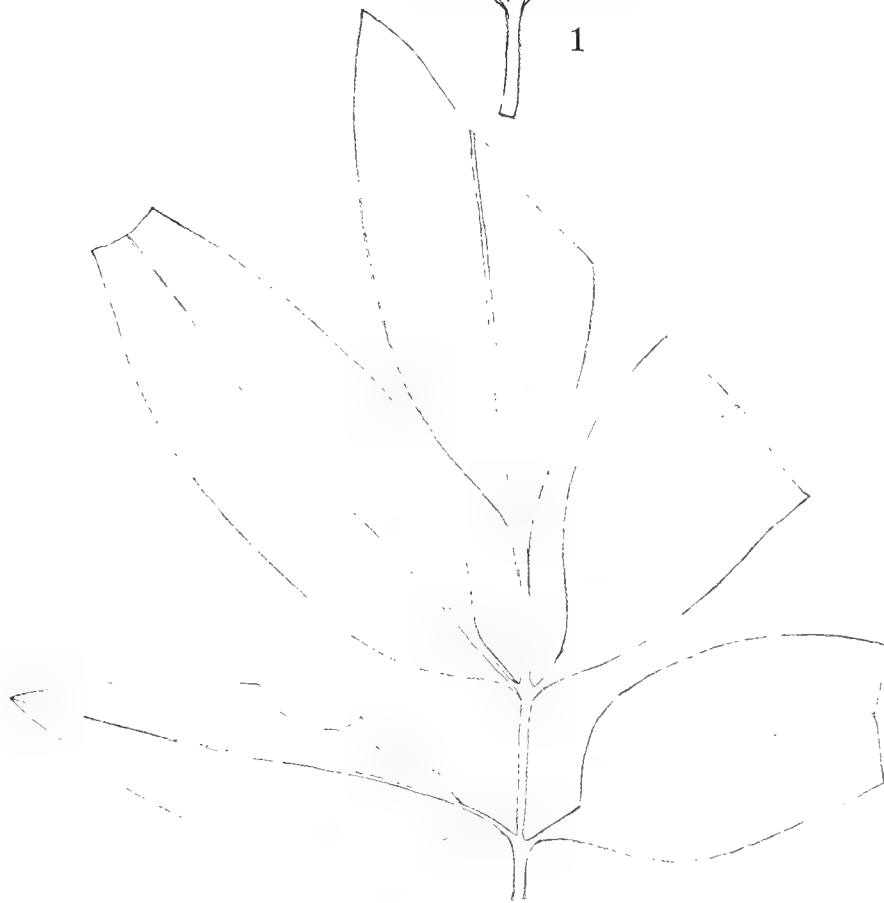

2

FOSSIL PLANTS FROM THE CHEYENNE SANDSTONE.

1, *Stereulia towneri* (Lesquerou) Berry; 2, *Sapindopsis magnifolia* Fontaine. Collected near Belvidere, Kans.



ARALIA RAVNIANA HEER.

From Cheyenne sandstone near Belvidere, Kans. About four-fifths natural size.

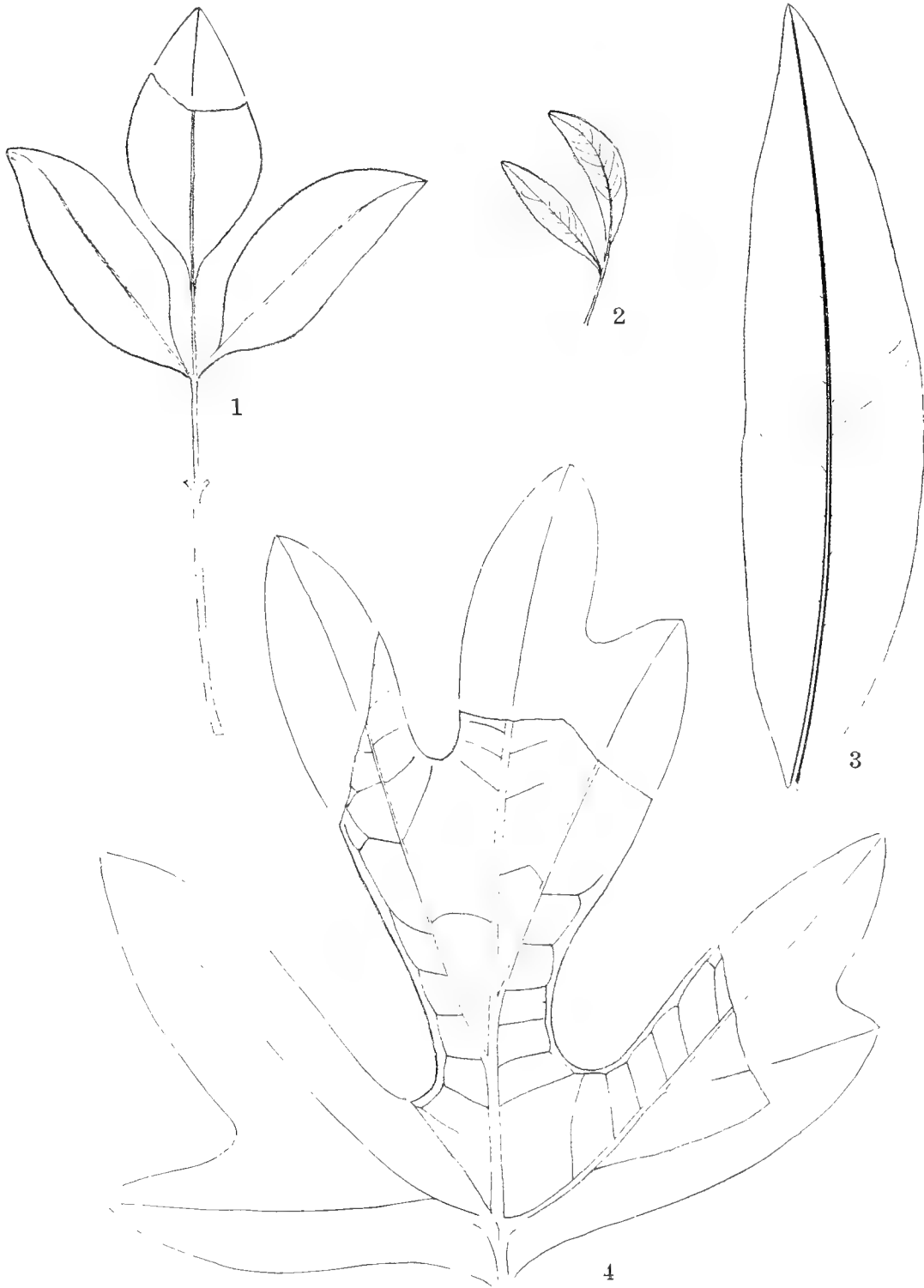

FOSSIL PLANTS FROM THE CHEYENNE SANDSTONE.

1, 2, *Sapindopsis brevifolia* Fontaine; 3, *Sapindopsis magnifolia* Fontaine; 4, *Aralia ravniiana* Heer. All collected near Belvidere, Kans.

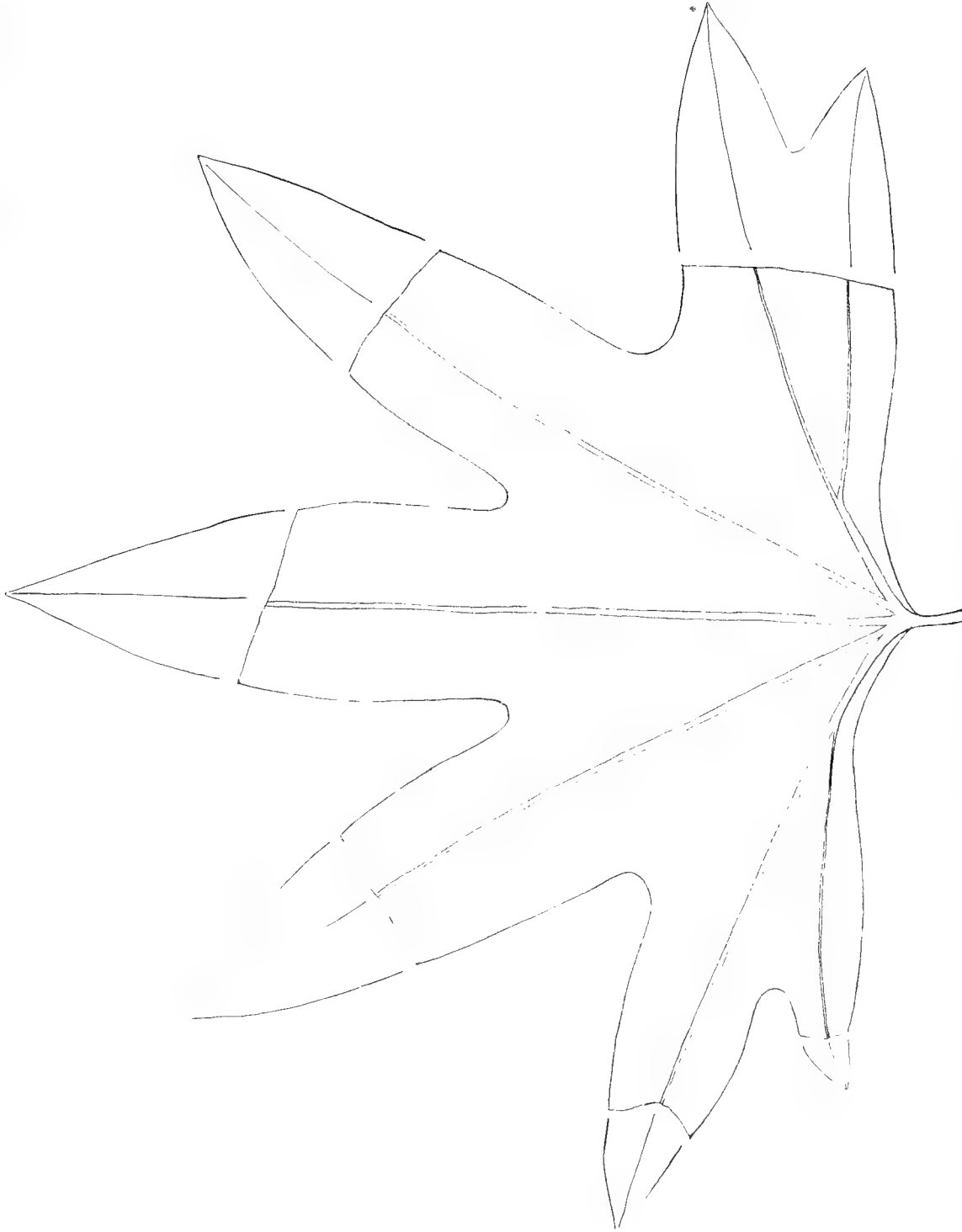

STERCULIA TOWNERI (LESQUEREUX) BERRY.
From Cheyenne sandstone near Belvidere, Kans. About four-fifths natural size.

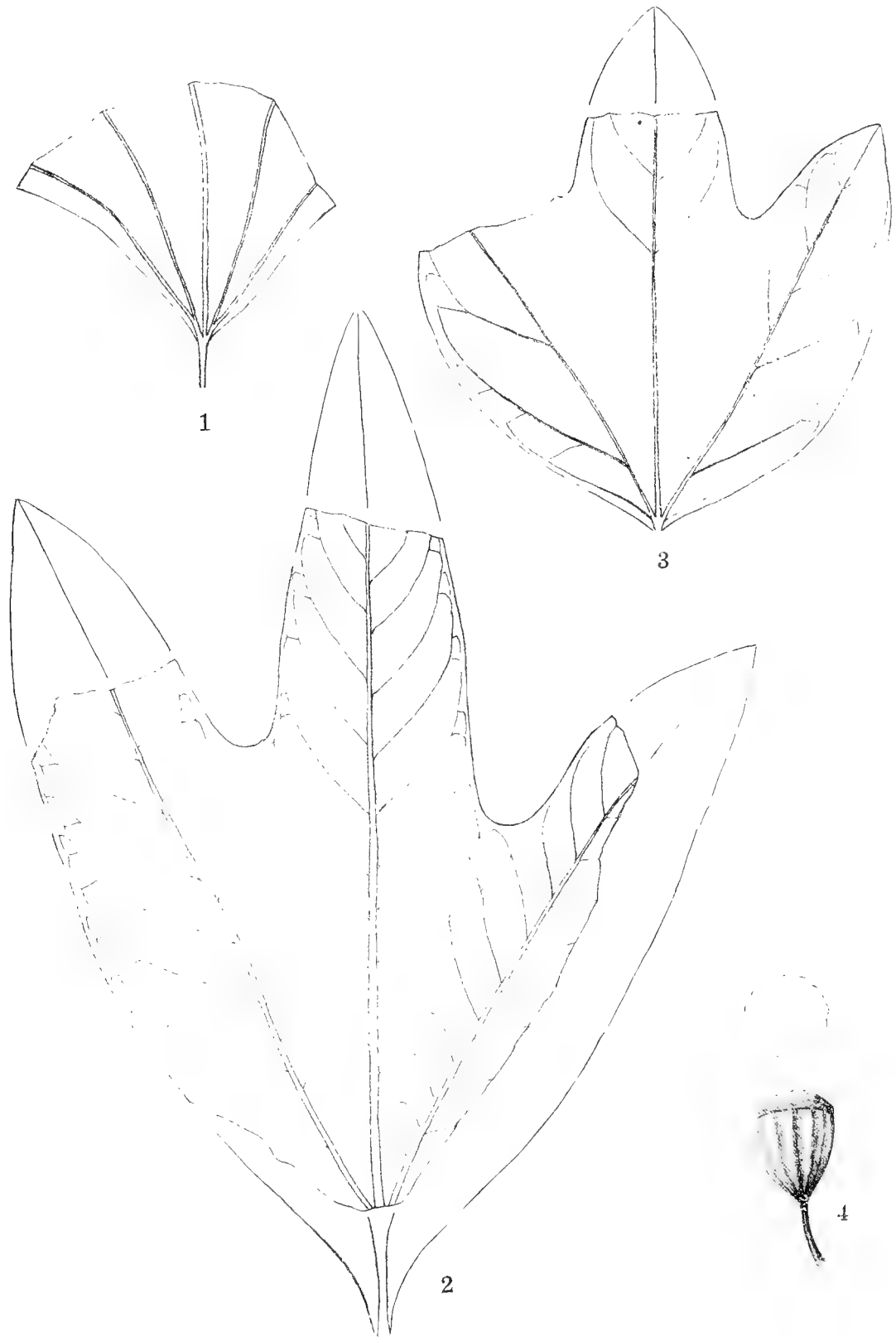

FOSSIL PLANTS FROM THE CHEYENNE SANDSTONE.

1, *Stereonites towneri* Lesquereux; Berry; 2, *Avalonsoides cretacea* (Newberry) Berry; 3, *Sassafras nudii* Lesquereux;
4, *Carpolithus helveticus* Berry. All collected near Belvidere, Kans.

INDEX.

	Page.		Page.
A.			
<i>Abietes ernstinae</i> Lesquereux, description of.....	212	Bend series, units K and L of well borings from.....	13-15
<i>longifolius</i> (Fontaine) Berry, description of.....	211-212	volcanic origin of material from.....	12
plate showing.....	225	white shale in well borings from.....	12
Accuracy in computations, excessive.....	41	<i>Benzoin venustum</i> (Lesquereux) Knowlton, description of.....	171-172
Acknowledgment for aid.....	22	<i>venustum</i> , plate showing.....	181
Akinetic surface, proposed use of term.....	8	Berry, Edward Wilber, fossils determined by.....	153-154
Alignment charts, nature of.....	42	The flora of the Cheyenne sandstone of Kansas.....	199-225
preparation and use of.....	44-46, 48, 49-50	The flora of the Woodbine sand at Arthurs Bluff, Tex.....	153-181
Allen, E. G., acknowledgment to.....	22	Big Horn Mountains, Ariz., hills of chloritic schist at north end	
<i>Andromeda novaeacarsariae</i> Hollick, description of.....	177-178	of, plate showing.....	184
<i>novaeacarsariae</i> , plate showing.....	181	<i>Biloculina ornata</i> D'Orbigny, description of.....	143
<i>snowii</i> Lesquereux, description of.....	178	<i>ornata</i> , plate showing.....	150
<i>Anomalina bilateralis</i> Cushman, n. sp., description of.....	97-98, 137	sp.?, description of.....	105
<i>bilateralis</i> , plate showing.....	115	sp.?, plate showing.....	122
<i>grosserugosa</i> (Gümbel) H. B. Brady? var., description of.....	98	Bingen sand, relation of flora of, to that of the Woodbine sand.....	156-157
plate showing.....	115	Black Butte, Ariz., plate showing.....	185
<i>mississippiensis</i> Cushman, n. sp., descriptions of.....	98, 137	Black Rock Canyon, Ariz., section in.....	70
plate showing.....	115	Black Rock Spring, Ariz., section near.....	75
<i>vicksburgensis</i> Cushman, n. sp., description of.....	137	Bloomington, Utah, sections on Virgin River near.....	75-76, 77
plate showing.....	152	Bloomington dome, Utah, section at.....	74
Antelope Hill, Ariz., sandstone composing.....	188	<i>Bolivina amygdalaeformis</i> H. B. Brady, description of.....	91
Antelope Wash, Ariz., section on.....	70	<i>amygdalaeformis</i> , plate showing.....	109
<i>Aralia newberryi</i> Berry, description of.....	220-221	<i>cookei</i> Cushman, n. sp., description of.....	126
<i>ravniana</i> Heer, description of.....	219-220	plate showing.....	146
plate showing.....	225	<i>frondea</i> Cushman n. sp., description of.....	126-127
<i>saportana</i> Lesquereux?, description of.....	177	plate showing.....	146
<i>wellingtoniana</i> Lesquereux, description of.....	176-177	<i>mississippiensis</i> Cushman n. sp., description of.....	92
plates showing.....	181	plate showing.....	109
<i>Araliopsoides cretacea</i> (Newberry) Berry, description of.....	221-222	<i>nitida</i> H. B. Brady, description of.....	91
<i>cretacea</i> , plate showing.....	225	plate showing.....	109
Arizona, northwestern. See Mohave County, Ariz.		<i>robusta</i> H. B. Brady, description of.....	91-92
Arthurs Bluff, Tex., fossil plants collected at.....	153	<i>vicksburgensis</i> Cushman, n. sp., description of.....	126
<i>Articulina byramensis</i> Cushman, n. sp., descriptions of.....	103, 143	plate showing.....	146
<i>byramensis</i> , plate showing.....	121	cf. <i>B. punctata</i> D'Orbigny, description of.....	126
<i>Arundo groenlandica</i> Heer?, description of.....	213	<i>Brachyphyllum macrocarpum formosum</i> Berry, description of.....	160-161
<i>Asplenium dicksonianum</i> Heer, description of.....	207-208	<i>macrocarpum formosum</i> , plate showing.....	181
<i>Asterigerina subacuta</i> Cushman, n. sp., description of.....	100	<i>Bulimina ovata</i> D'Orbigny?, description of.....	92
<i>subacuta</i> , plate showing.....	118	<i>ovata</i> , plate showing.....	110
B.			
Bancroft, Howland, cited.....	185	<i>pupoides</i> D'Orbigny, description of.....	127
Basalt resting on a conglomerate of basalt and other boulders near		plate showing.....	146
Toquerville, Utah, plate showing.....	67	<i>Bulimnella contraria</i> (Reuss) Cushman, description of.....	128
Bassler, Harvey, Reeside, John B., jr., and, Stratigraphic sections		<i>subteres</i> H. B. Brady var. <i>angusta</i> Cushman, n. var., descrip-	
in southwestern Utah and northwestern Arizona.....	53-77	tion of.....	127-128
Beaver Dam Mountains, Utah, section in.....	76-77	plate showing.....	146
Bedding planes, classification of, difficulties in.....	5	Bullrush, Ariz., section near.....	70
"Bellerophon limestone," fossils collected in.....	66	Byram, Miss., fossils found near.....	83-85
Bend series, correlation of well sections with subdivisions of.....	15-16	Byram calcareous marl, deposition of.....	88
difference between shales in.....	9	exposures of, at Byram, Miss.....	81
distinction between black shale and black limestone in.....	9	at Woodward, Miss.....	82
investigation of, difficulty with staining matter.....	2	near Vicksburg, Miss.....	80-81
flint treated separately in.....	2	on Leaf River, Miss.....	82
lithologic correlation in, introduction to discussion of.....	6-7	fauna of, descriptions of.....	89-105
nature of oil-producing beds in.....	20	occurrence of.....	81, 82-85
object and methods of the investigation of.....	1-5	relationships of.....	87-88
position of oil sands in.....	18-20	features of.....	79-80
"Smithwick lime" in well borings from.....	16	foraminifera found in, at the type station.....	124-125
summary and conclusions on.....	20-22	C.	
time required for lithologic work on.....	20	Caliche, occurrence of, in the lower Gila region, Ariz.....	190
unit A of well borings from.....	7	<i>Carpoithus belviderensis</i> Berry, n. sp., description of.....	224
unit B of well borings from.....	7-9	<i>belviderensis</i> , plate showing.....	225
units C and C' of well borings from.....	9-10	sp. 1, description of.....	179
unit D of well borings from.....	10-11	sp. 2, description of.....	180
units E, F, and G of well borings from.....	11-12	plate showing.....	181
units H and I of well borings from.....	12-13	sp. 3, description of.....	180
unit J of well borings from.....	13	plate showing.....	181
		Cartesian coordinates, disadvantages of.....	41
		Casey, T. L., cited.....	79

	Page.		Page.
<i>Cassidulina crassa</i> D'Orbigny, description of.....	128	<i>Discorbis auracana</i> (D'Orbigny) Cushman, description of.....	135
Charts for stratigraphic computations, preparation and use of.....	44-50	<i>auracana</i> , plate showing.....	149
	45, 45-46, 48, 49-50	<i>bertheloti</i> (D'Orbigny) Cushman, description of.....	135
Cheyenne sandstone of Kansas, flora of, age of.....	204-206	plate showing.....	149
flora of, climate and conditions of growth and embedment.....	203	<i>byramensis</i> Cushman, n. sp., description of.....	96
descriptions of.....	207-224	plate showing.....	113
early work on.....	200	<i>orbicularis</i> (Terquem) Berthelin, description of.....	96
features of.....	202-203	plate showing.....	113
stratigraphic distribution of.....	206	Distance to a stratum, method for computing.....	46-48
fossil plants from, plates showing.....	225	Dome Rock Mountains, Ariz., plug of latite in, plate showing.....	185
invertebrates in.....	199		
localities in, from which fossils were collected.....	202	E.	
mechanical analysis of.....	203-204	Eagle Tail Mountains, coloration of rocks in.....	186
microscopic examination of.....	204	<i>Ehrenbergina glabrata</i> Cushman, n. sp., description of.....	93
nature of.....	199	<i>glabrata</i> , plate showing.....	111
Chinle formation in Utah, features of.....	62-63		
near Springfield, Utah, plate showing.....	62	F.	
Cinder cones north of St. George, Utah, plates showing.....	66	<i>Fristmantelia oblonga</i> Ward, description of.....	222-224
<i>Cinnamomum membranaceum</i> (Lesquereux) Hollick, description of.....	174	<i>oblonga</i> , plate showing.....	225
<i>newberryi</i> Berry, description of.....	173-174	<i>Ficus daphnogenoides</i> (Heer) Berry, description of.....	163-164
plate showing.....	181	<i>daphnogenoides</i> , plate showing.....	181
<i>Cissites formosus</i> Heer, description of.....	170-171	<i>glaseocana</i> Lesquereux, description of.....	164
<i>formosus</i> , plate showing.....	151	Foraminifera. See Cushman, Joseph A.	
<i>Cladophlebis dakotensis</i> (Lesquereux) Berry, description of.....	207	Fossils, from well borings in the Bend series, Texas.....	16
Clanton Hills, Ariz., limestone composing.....	188	occurrence of, in the lower Gila region.....	189-190
<i>Clavulina byramensis</i> Cushman, n. sp., description of.....	92		
<i>byramensis</i> , plate showing.....	110	G.	
Coalpits Wash, near Grafton, Utah, panorama along east side of, plate showing.....	59	Gabb, William M., cited.....	27, 28
Coconino sandstone in Utah and Arizona, features of.....	57-58	<i>Gaudryina triangularis</i> Cushman, description of.....	127
south of Hurricane, Utah, plate showing.....	58	sp. ?, description of.....	127
<i>Colutea primordialis</i> Heer, description of.....	168	plate showing.....	146
Computations, graphic, facilities needed for.....	39-40	Gila, lower, region, Ariz., basal complex of, age of.....	185-186
graphic, publications on.....	39	basal complex of, classes of rocks in.....	183-184
numerical, disadvantages of.....	41	igneous rocks in.....	184
Computer, trigonometric, advantages of.....	50	least-metamorphosed sediments in.....	185
trigonometric, construction of.....	50-51	metamorphosed schistose rocks in.....	184-185
use of.....	52	nature and distribution of.....	184-186
Cooke, C. Wythe, cited.....	123	faults older than the Tertiary lava in.....	192-193
<i>Orthaulax</i> , a Tertiary guide fossil.....	23-37	faults younger than the Tertiary lava in.....	193
The Byram calcareous marl of Mississippi.....	79-86	folds in.....	192
<i>Cornophyllum vetustum</i> Newberry, description of.....	177	geologic map of.....	In pocket.
<i>Cornuspira involvens</i> (Reuss) Reuss, descriptions of.....	101, 140	intrusive rocks in.....	187
<i>involverns</i> , plate showing.....	119	mineral deposits in.....	197
Court House Rock, Ariz., description of.....	187	Paleozoic and Mesozoic events in.....	194
Cragin, F. W., fossils determined by.....	155	pre-Cambrian events in.....	194
Cretaceous (?) sandstone in Utah, features of.....	65	Quaternary basalt in.....	191-192
Cretaceous time, sequence of events in.....	201-202	Quaternary faults in.....	193
Cretaceous (?) variegated shale in Utah, features of.....	64-65	Quaternary history of.....	196-197
<i>Cristellaria conergens</i> ? Bornemann, description of.....	130	Quaternary sediments in.....	190-191
<i>cultrata</i> (Montfort) Parker and Jones, description of.....	130	rocks of, variety of.....	183
plate showing.....	145	situation and development of.....	183
<i>rotulata</i> (Lamarck) D'Orbigny, description of.....	130	structure of.....	192-193
plate showing.....	149	Tertiary history of.....	195-196
<i>ricksburgensis</i> Cushman, n. sp., description of.....	130-131	Tertiary sedimentary formations in, features of.....	186
plate showing.....	145	fossils in.....	189-190
sp., description of.....	93	nature and distribution of.....	188-189
<i>Cupressinoxylon cheyennense</i> Penhallow, description of.....	212-213	Tertiary lavas in, nature and distribution of.....	186-188
Cushman, Joseph A., The foraminifera of the Mint Spring calcareous marl member of the Marianna limestone.....	123-152	Girty, G. H., cited.....	67, 68
The Byram calcareous marl of Mississippi and its Foraminifera.....	87-122	fossils determined by.....	66-68
<i>Cycadeoidea munda</i> Cragin, description of.....	209	Glauconite, occurrence of, above stratigraphic breaks.....	3-4, 20-21
<i>Cycadosperrimum lineatum</i> Lesquereux, description of.....	209	<i>Gleichenia? bohemica</i> (Corda) Berry, description of.....	208-209
		<i>bohemica</i> , plate showing.....	225
D.		<i>nordenskiöldi</i> Heer, description of.....	208
Dakota sandstone, use of term.....	199-200	plate showing.....	225
Dall, William H., cited.....	23, 27, 29-30	<i>Globigerina bulloides</i> D'Orbigny, descriptions of.....	95, 134
fossils determined by.....	189-190	<i>bulloides</i> , plate showing.....	113
Denison, Tex., fossil plants collected at.....	153	<i>dutertrei</i> D'Orbigny, description of.....	134
Depth to a stratum, graphic computation of.....	48	<i>triloba</i> Reuss, description of.....	95
<i>Deroliqua insigniformis</i> Berry, description of.....	167	<i>Glyptostrobus gracillimus</i> Lesquereux, erroneous identification of.....	209-210
Diamond Valley, Utah, section on north side of.....	77	Goldman, Marcus I., cited.....	203-204
<i>Diospyros primaeva</i> Heer, description of.....	178-179	Lithologic subsurface correlation in the "Bend series" of north-central Texas.....	1-24
<i>primaeva</i> , plate showing.....	181	Gonzales Wells, Ariz., plate showing.....	184
		<i>Gypsina rubra</i> (D'Orbigny) Heron-Allen and Earland, descriptions of.....	98, 139
		<i>rubra</i> , plate showing.....	116

H.	Page.		Page.
Hacks Canyon, Ariz., section in	69	Mohave County, Ariz., fossils collected in	66-68
Harrisburg dome, Utah, section at	73-74	general section in	54-56
Harrisburg gypsiferous member of the Kaibab limestone, fossils collected from	66	local sections in	69-77
<i>Hauerina fragilissima</i> (H. G. Brady) Millett, description of	103	stratigraphy of	54-66
<i>fragilissima</i> , plate showing	121	structure of	54
sp.,? description of	103	<i>Myrica emarginata</i> Heer, description of	161
Haynes Bluff, Miss., fossils found in	83-85	<i>longa</i> (Heer) Heer, description of	161-162
Heald, K. C., acknowledgment to	22	plate showing	181
Heilprin, A., cited	28-29	<i>Myrtonium geinitzi</i> (Heer) Berry, description of	175-176
Hill, R. T., cited	18	N.	
Hurricane, Utah, section south of	71-72	<i>Nodosaria communis</i> D'Orbigny, description of	129
J.		<i>communis</i> plate showing	147
Jurassic limestone and shale in Utah, features of	64	<i>filiformis</i> D'Orbigny, description of	129
Jurassic sandstone, in Utah, features of	63-64	plate showing	147
massive, near Springdale, Utah, plate showing	62	<i>obliqua</i> (Linnaeus) H. B. Brady, description of	129-130
north of St. George, Utah, plate showing	62	plate showing	147
K.		sp., description of	93
Kaibab limestone, fossils collected from	66-67	plate showing	110
in Utah and Arizona, features of	58-59	sp.?, description of	93
south of Hurricane, Utah, plate showing	58	plate showing	110
west of Virgin City, Utah, plate showing	58	sp.?, description of	130
Knowlton, F. H., fossils determined by	153	plate showing	147
L.		<i>Nonionina advena</i> Cushman, n. sp., description of	139-140
<i>Lagena hexagona</i> (Williamson) Siddall, description of	129	<i>advena</i> , plate showing	149
<i>hexagona</i> , plate showing	146	<i>scapha</i> (Fichtel and Moll) Parker and Jones, description of	100, 139
<i>laevigata</i> (Reuss) Terrigi, description of	128	plate showing	117
<i>orbignyana</i> (Seguenza) H. B. Brady var. <i>flintii</i> , Cushman n. var., description of	129	<i>umbilicatula</i> (Montagu) Parker, Jones, and H. B. Brady, description of	100, 139
var. <i>flintii</i> , plate showing	146	plate showing	117
<i>striata</i> (D'Orbigny) Reuss var. <i>substriata</i> Williamson, description of	128	<i>Nummulites</i> sp., description of	100-101
var. <i>substriata</i> , plate showing	146	sp., plate showing	118
Latite, plug of, in the Dome Rock Mountains, plate showing	185	O.	
La Verkin, Utah, section near	72	Oilsands, position of, in the "Bend series," in north-central Texas	18-20
<i>Laurophyllum minus</i> Newberry, description of	175	<i>Oreodaphne alabamensis</i> , Berry description of	172-173
<i>Laurus antecessans</i> Lesquereux?, description of	175	<i>alabamensis</i> , plate showing	181
<i>plutonia</i> Heer, description of	174-175	<i>Orthaulax</i> , correlation table of	25-26
plate showing	151	criteria for discriminating species of	24
Leaf River, Miss., exposure of Byram marl on	82	description of	27-28
fossils found on	83-85	generic features of	23-24
<i>Lepidocyclusina supera</i> (Conrad) H. Douvillé, description of	101	occurrence and stratigraphic position of species of	24-26
Lesquereux, Leo, cited	177, 207, 209, 212	species of, plates showing	33-37
Lime, conditions affecting the deposition of	2	<i>aguadillensis</i> Maury, description of	30-31
<i>Liriodendron quercifolium</i> Newberry, description of	166	occurrence and stratigraphic position of	25
<i>quercifolium</i> , plate showing	181	plate showing	36, 37
M.		<i>caepa</i> Cooke, n. sp., description of	31
<i>Magnolia lacocana</i> Lesquereux, description of	165	occurrence and stratigraphic position of	25
<i>speciosa</i> Heer, description of	165	plate showing	37
plate showing	181	<i>gabbi</i> , description of	29-30
<i>Malapoenna facilifolia</i> (Lesquereux) Knowlton, description of	172	occurrence and stratigraphic position of	25
<i>Massilina crusta</i> Cushman, n. sp., description of	104	plates showing	35, 36
<i>crusta</i> , plate showing	122	<i>inornatus</i> , description of	28
<i>decorata</i> Cushman, n. sp., description of	143	occurrence and stratigraphic position of	24-25
plate showing	151	plate showing	31
<i>occlusa</i> Cushman, n. sp., description of	104	<i>pugnax</i> , description of	28-29
plate showing	122	occurrence and stratigraphic position of	25
var. <i>costulata</i> Cushman, n. var., description of	104	plates showing	34, 35
Matteson, W. G., cited	18	Osage Rock, near Belvidere, Kans., plate showing	202
Maury, Carlotta J., cited	24, 30-31	Osborne Wash., Ariz., plate showing	188
Mertie, J. B., jr., Graphical and mechanical computation of thickness of strata and distance to a stratum	39-52	P.	
"Millsap division," use of name	15-16	<i>Palcoecia laurina</i> Lesquereux, description of	167-168
Minerals, marking of horizons by	21	<i>laurina</i> , plate showing	181
Mint Spring marl, features of	123	Palmer, H. S., method of, for making stratigraphic computations	44
fossils found in	82, 83-85	<i>Patellina advena</i> Cushman, n. sp., description of	135
foraminifera found in, at six stations	124-125	<i>advena</i> , plate showing	148
Moenkopi formation, features of, in Utah and Arizona	59-62	Percentage log, description of	1-2
fossils collected from	67-68	Phosphate rock, conditions affecting deposition of	4
north of Virgin City, Utah, plate showing	67	<i>Platanus latior</i> (Lesquereux) Knowlton, description of	164-165
west of Virgin City, Utah, plate showing	58	Plummer, F. B., cited	6, 15
Mohave County, Ariz., age of the formations in	66-69	<i>Podozamites lanceolatus</i> (Lindley and Hutton) F. Braun, description of	159-160
features of	53-54	<i>lanceolatus</i> , plate showing	181
		<i>Polymorphina advena</i> Cushman, n. sp., description of	132
		<i>advena</i> , plate showing	148
		<i>amygdaloides</i> (Reuss) Reuss, description of	95, 132
		plate showing	112

	Page.		Page.
<i>Polymorphina byramensis</i> Cushman, n. sp., description of.....	94, 131	<i>Rotalia dentata</i> Parker and Jones, description of.....	100
plate showing.....	111	plate showing.....	117
<i>cuspidata</i> H. B. Brady, description of.....	133	var. <i>parva</i> Cushman, n. var., description of.....	139
plate showing.....	147	plate showing.....	152
var. <i>costulata</i> Cushman, n. var.....	133	<i>ricksburgensis</i> Cushman, n. sp., description of.....	139
plate showing.....	148	plate showing.....	152
<i>equalis</i> D'Orbigny, description of.....	132	Roxana Petroleum Corporation, acknowledgment to.....	22
plate showing.....	148	Rudd No. 1 well, location of.....	5-6
<i>gibba</i> D'Orbigny, description of.....	93-94, 132	log of, plate showing.....	In pocket.
plate showing.....	111	section of, correlated with type section.....	15
fistulose form, description of.....	94	sections of, thicker than-corresponding sections of Seaman	
plate showing.....	112	well.....	6, 7, 17
<i>problema</i> D'Orbigny?, description of.....	94-95, 131-132		
plate showing.....	112	S.	
<i>regina</i> H. B. Brady, Parker, and Jones, description of.....	94, 131	Saddle Mountain, Ariz., plate showing.....	188
plate showing.....	112, 147	St. George, Utah, sections north, east, and south of.....	73-75, 76-77
<i>spinosa</i> (D'Orbigny) Egger, description of.....	133	<i>Saïx delta</i> Lesquereux, description of.....	163
plate showing.....	148	<i>lesquereuxii</i> Berry, description of.....	162
<i>ricksburgensis</i> Cushman, n. sp., description of.....	133	<i>Sapindopsis beldereensis</i> Berry, n. sp., description of.....	216-217
plate showing.....	148	<i>beldereensis</i> , plate showing.....	225
<i>Populus harkeriana</i> Lesquereux, description of.....	163	<i>breifolia</i> Fontaine, description of.....	216
<i>Pulvinulina advena</i> Cushman, n. sp., description of.....	99	plate showing.....	225
<i>advena</i> , plate showing.....	116	<i>magnifolia</i> Fontaine, description of.....	214-215
<i>byramensis</i> Cushman, n. sp., description of.....	99, 138	plate showing.....	225
plate showing.....	116	<i>variabilis</i> Fontaine, description of.....	213-214
<i>glabrata</i> Cushman, n. sp., description of.....	99, 138	plate showing.....	225
plate showing.....	116	<i>Sapindus morrisoni</i> Heer, description of.....	168
Q.		<i>Sassafras mudgii</i> Lesquereux, description of.....	219
<i>Quinqueloculina bicostata</i> D'Orbigny, description of.....	141	<i>mudgii</i> , plate showing.....	225
<i>bicostata</i> D'Orbigny var., description of.....	102	Seaman No. 1 well, location of.....	5-6
var., plate showing.....	120	log of, comparison of synthetic log with.....	17-18
<i>contorta</i> D'Orbigny, description of.....	142	plate showing.....	In pocket.
plate showing.....	151	oil in.....	12
<i>cookei</i> Cushman, n. sp., description of.....	141	sections of, thicker than corresponding sections of Rudd	
plate showing.....	150	well.....	6, 7, 17
<i>crassa</i> D'Orbigny?, description of.....	102	<i>Sequoia condita</i> , Lesquereux, description of.....	209-211
plate showing.....	121	<i>condita</i> , plate showing.....	225
<i>cuterana</i> D'Orbigny, description of.....	102, 141	<i>gracilima</i> Newberry, erroneous naming of.....	209-210
plate showing.....	120	Shinarump conglomerate, features of, in Utah and Arizona.....	62
<i>glabrata</i> Cushman, n. sp., description of.....	141	north of Virgin City, Utah, plate showing.....	67
plate showing.....	151	<i>Siphonina advena</i> Cushman, description of.....	98, 137
<i>lamarckiana</i> D'Orbigny, description of.....	142-143	<i>advena</i> , plate showing.....	116
<i>lustra</i> Cushman, n. sp., description of.....	141-142	Smith's Mesa, Utah, section in.....	73
plate showing.....	150	view northward toward, plate showing.....	59
<i>semundum</i> (Linnaeus) D'Orbigny, description of.....	142	<i>Spirillina limbata</i> H. B. Brady var. <i>bipunctata</i> Cushman, n. var.,	
<i>tessellata</i> Cushman, n. sp., description of.....	142	description of.....	134-135
plate showing.....	150, 151	<i>limbata</i> var. <i>bipunctata</i> , plate showing.....	149
<i>tenusta</i> Karrer?, var., description of.....	102-103	<i>subdecorata</i> Cushman, n. sp., description of.....	95
plate showing.....	120	plate showing.....	113
<i>ricksburgensis</i> Cushman, n. sp., description of.....	141	<i>Sproloculina antillarum</i> D'Orbigny, description of.....	140
plate showing.....	151	<i>antillarum</i> , plate showing.....	150
<i>vulgaris</i> D'Orbigny, description of.....	142	<i>byramensis</i> Cushman, n. sp., description of.....	101
plate showing.....	149	plate showing.....	119
sp., description of.....	103	<i>grateloupi</i> D'Orbigny, description of.....	101
plate showing.....	120	plate showing.....	119
		<i>imprimata</i> Cushman, n. sp., description of.....	101-102, 140
R.		plate showing.....	119
Red Bluff clay, fossils found in.....	82, 83-85	<i>Sterculia lugubris</i> Lesquereux?, description of.....	171
Red wall limestone, features of, in Utah and Arizona.....	56-57	<i>lugubris</i> , plate showing.....	181
Reeside, John B., jr., and Bassler, Harvey, Stratigraphic sections		<i>micronata</i> Lesquereux, description of.....	218
in southwestern Utah and northwestern Arizona.....	53-77	<i>louneri</i> (Lesquereux) Berry, description of.....	217-218
Reeves, Frank, cited.....	18	plate showing.....	225
Rhamey Hill, Tex., fossil plants collected from.....	153	Stratigraphic units, use of term.....	5
<i>Rhamnus tenax</i> Lesquereux, description of.....	169-170	<i>Strombus costatus</i> , plate showing.....	34
<i>tenax</i> , plate showing.....	181	Sulphide, conditions affecting deposition of.....	4-5
<i>Rhus reddiformis</i> Berry, description of.....	169	Supai formation, features of, in Utah and Arizona.....	57-58
<i>reddiformis</i> , plate showing.....	181	Synthetic log, description of.....	3
Rhythm in movements of ancient seashores.....	201		
Rock Canyon ARIZ., section at head of.....	70-71	T.	
section at mouth of.....	71	Tertiary (?) sandstone, features of, in Utah.....	65
Rock Canyon conglomerate member of the Moenkopi formation,		Tertiary (?) and Quaternary rocks, features of, in Utah and	
fossils collected from.....	67	Arizona.....	66
Ross, Clyde P., Geology of the lower Gila region, Ariz.....	183-197	Texas, north-central, generalized log for.....	1-20
<i>Rotalia byramensis</i> Cushman, n. sp., description of.....	99, 138	generalized log for, plate showing.....	In pocket.
<i>byramensis</i> plate showing.....	117	<i>Textularia agglutinans</i> D'Orbigny, description of.....	89
		<i>agglutinans</i> , plate showing.....	108

	Page.		Page.
<i>Testularia folium</i> Parker and Jones, description of.....	90-91	<i>Vaginulina legumen</i> (Linnaeus) D'Orbigny var. <i>elegans</i> (D'Orbigny) Fornasini, plate showing.....	111
plate showing.....	108	Vaughan, T. W., fossils determined by.....	82
<i>mississippiensis</i> , description of.....	90, 125-126	<i>Verneuilina spinulosa</i> Reuss var. <i>glabrata</i> Cushman, n. var., description of.....	92
plate showing.....	108	<i>rectimargo</i> Cushman, n. sp., description of.....	127
<i>subhauerii</i> Cushman, description of.....	89-90, 126	plate showing.....	146
plate showing.....	108	<i>Vertebralina advena</i> Cushman, n. sp., description of.....	102
<i>tumidulum</i> , description of.....	89, 125	<i>advena</i> , plate showing.....	119
plate showing.....	109	sp., description of.....	102
Thickness of strata, graphic computation of, alinement chart for.....	44-46	plate showing.....	119
graphic computation of, data needed for.....	40	sp., description of.....	140
geometric construction for.....	40-41	<i>Viburnum robustum</i> Lesquereux, description of.....	179
trigonometric formula for.....	41	<i>robustum</i> , plate showing.....	181
graphic representation of.....	41-43	Vicksburg, Miss., exposures of Byram marl near.....	80-81
mathematical analysis of.....	43-44	fossils found near.....	81, 83-85
Toroweap Canyon, Ariz., section in.....	69-70	Vicksburg beds, early paleontologic work on.....	79
Triangle, right, graphic solution of.....	48-50	Virgin City, Utah, sections west of.....	72-73
right, graphic solution of, preparation and use of chart for.....	49-50	Virgin limestone member of the Moenkopi formation, fossils collected from.....	67-68
graphic solution of, alinement chart for.....	50	<i>Virgulina</i> sp., description of.....	92
<i>Tricalycites papyraceus</i> Hollick, description of.....	179	sp., plate showing.....	110
<i>papyraceus</i> , plate showing.....	181	W.	
<i>Triloculina oblonga</i> (Montagu) D'Orbigny, description of.....	104-105	Washington County, Utah, age of the formations in.....	66-69
<i>oblonga</i> , plate showing.....	122	features of.....	53-54
<i>peroblonga</i> Cushman, n. sp., description of.....	143	fossils collected in.....	66-68
plate showing.....	151	general section of.....	54-56
<i>rotunda</i> D'Orbigny, description of.....	104	local sections in.....	69-77
<i>sculpturata</i> Cushman, n. sp., description of.....	143	stratigraphy of.....	54-66
plate showing.....	150	structure of.....	54
<i>trigona</i> (Lamarck) D'Orbigny, description of.....	105	Washington dome, Utah, section in.....	74
<i>Trochodendroides</i> Berry, n. gen., description of.....	166	White, David, acknowledgment to.....	22
<i>rhomboides</i> (Lesquereux) Berry, description of.....	166-167	<i>Widdringtonites reichii</i> (Ettingshausen) Heer, erroneous identification of.....	209, 210
plate showing.....	181	Wolf Hole, Ariz., section north of.....	75
<i>Truncatulina americana</i> Cushman, description of.....	97	Woodbine, Tex., fossil plants collected at.....	153
<i>americana</i> , plate showing.....	114	Woodbine sand, fauna of.....	155
var., description of.....	136	flora of, descriptions of.....	159-180
<i>byramensis</i> Cushman, n. sp., description of.....	96-97, 136	distribution of, in other formations.....	159
plate showing.....	114	early collections of.....	153
<i>lobatula</i> (Walker and Jacob) D'Orbigny, description of.....	96, 135-136	features of.....	155-156
plate showing.....	114	plates showing.....	181
<i>pseudoungeriana</i> Cushman n. sp., description of.....	97, 136	relations of, to that of other formations.....	156-156
plate showing.....	114	naming of.....	174
<i>vicksburgensis</i> Cushman, n. sp., description of.....	136-137	nature and distribution of.....	154-155
plate showing.....	152	Woodwards, Miss., exposure of Byram marl at.....	82
U.		Woolsey Tank, Ariz., plate showing.....	189
Utah, southwestern. See Washington County, Utah.		bank of wash near, plate showing.....	189
<i>Uvigerina byramensis</i> , Cushman, n. sp., descriptions of.....	95, 133-134	Z.	
<i>byramensis</i> , plate showing.....	112	<i>Zizyphus lamarensis</i> Berry, description of.....	170
<i>pigmea</i> D'Orbigny, description of.....	134	<i>lamarensis</i> , plate showing.....	181
plate showing.....	149		
V.			
<i>Vaginulina legumen</i> (Linnaeus) D'Orbigny var. <i>elegans</i> (D'Orbigny) Fornasini, description of.....	93, 131		





PROFESSIONAL PAPER 129 PLATE I

DRILLER'S LOG
OF SEAMAN WELL

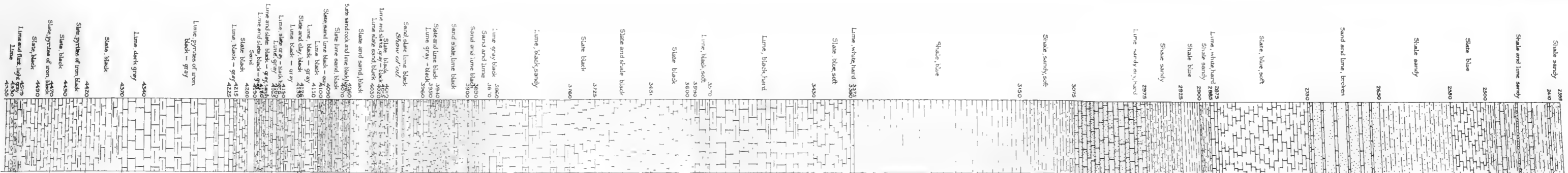

2
SYNTHETIC LOG
OF SEAMAN WELL

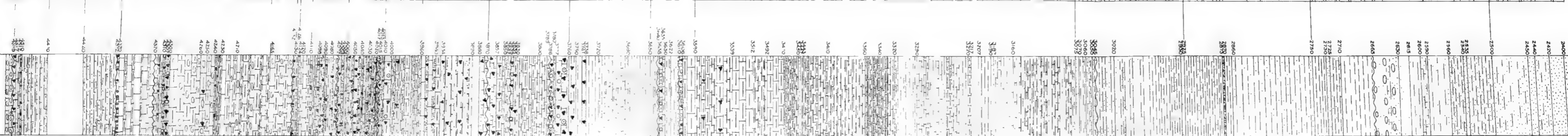

3
PERCENTAGE LOG
OF SEAMAN WELL

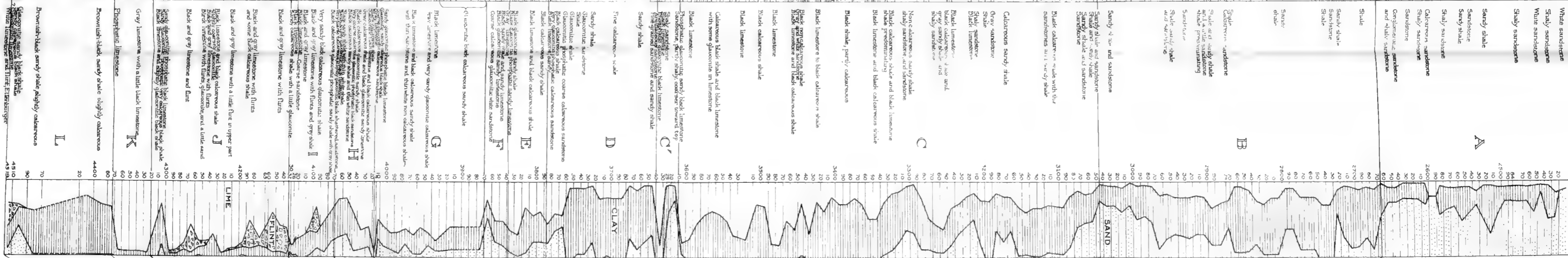

LOGS OF THE SEAMAN AND RUDD WELLS AND

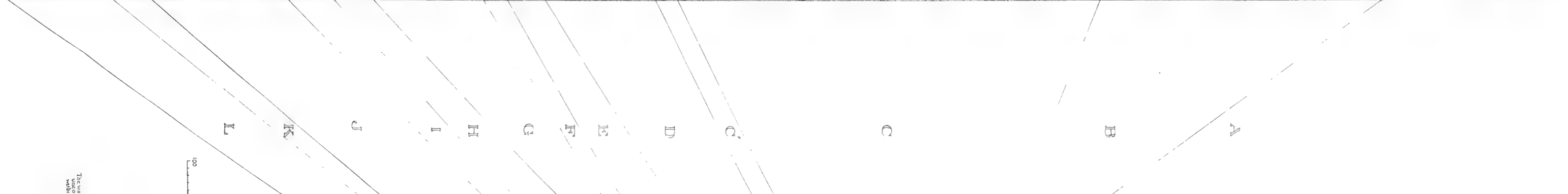

4
PERCENTAGE LOG
OF RUDD WELL

5
SYNTHETIC LOG
OF RUDD WELL

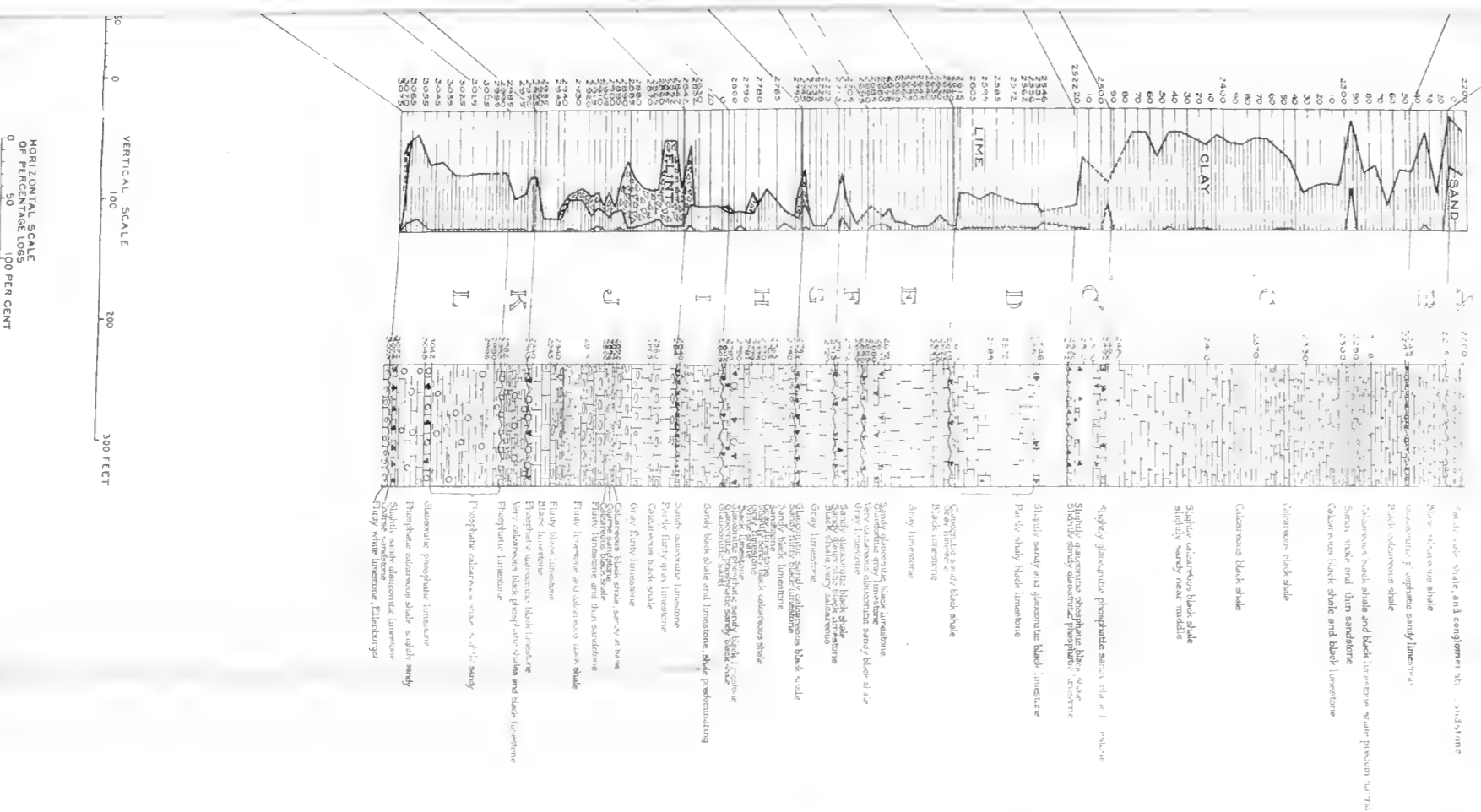

These lithologic boundaries of units which are generally used to represent information from the logs are shown as they appear in the logs. They are not necessarily in any implication as to their significance. (See text)

6
GENERALIZED LOG
FOR NORTH-CENTRAL TEXAS
FROM STUDIES IN THE SAND SEAMANT WELLS
THIS LOG WAS TAKEN FROM THE SAND SEAMANT WELLS

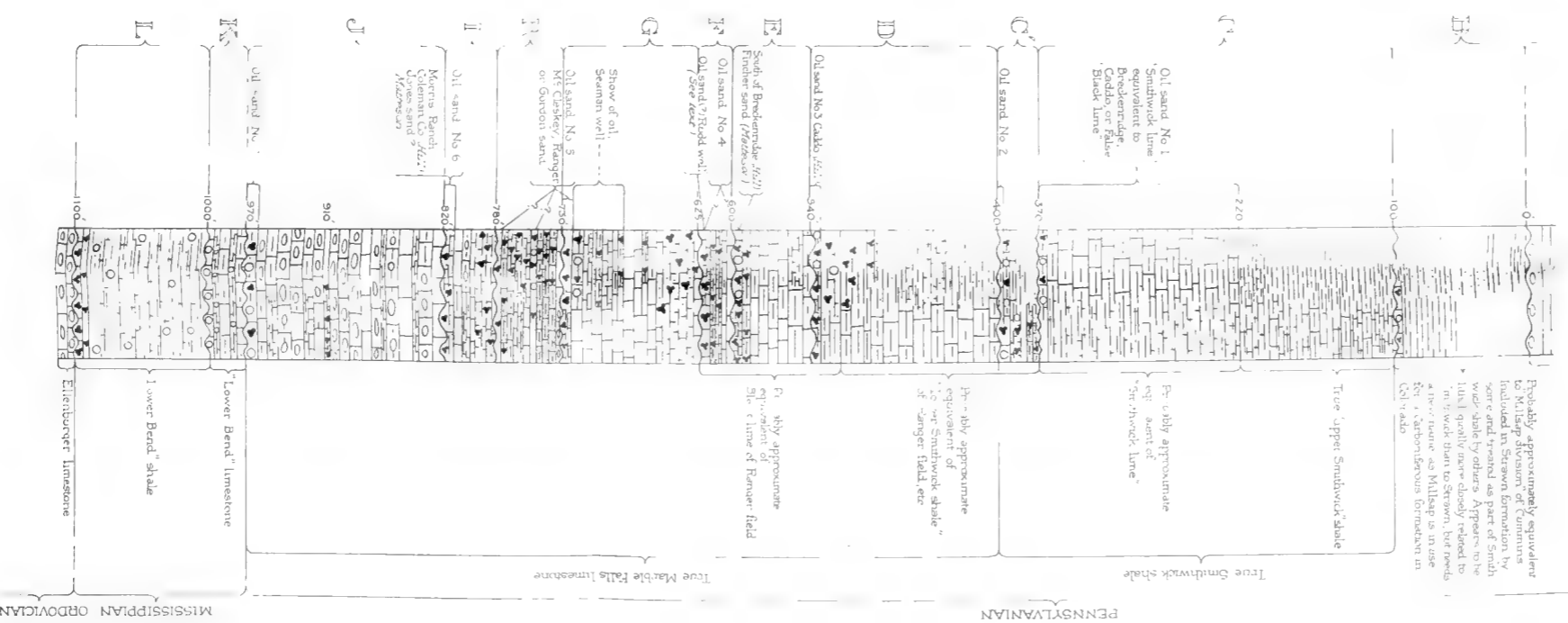

D A GENERALIZED LOG FOR NORTH-CENTRAL TEXAS



ePeak

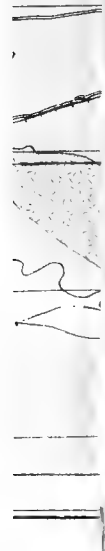



Compiled from data obtained in the field by Clyde P. Ross, published geologic maps prepared by Howland Bancroft and E. L. Jones covering parts of the northwestern portion of the region, an unpublished map of the Sierra Estrella by F. C. Schrader, and, on the southern border, data furnished by Kirk Bryan.

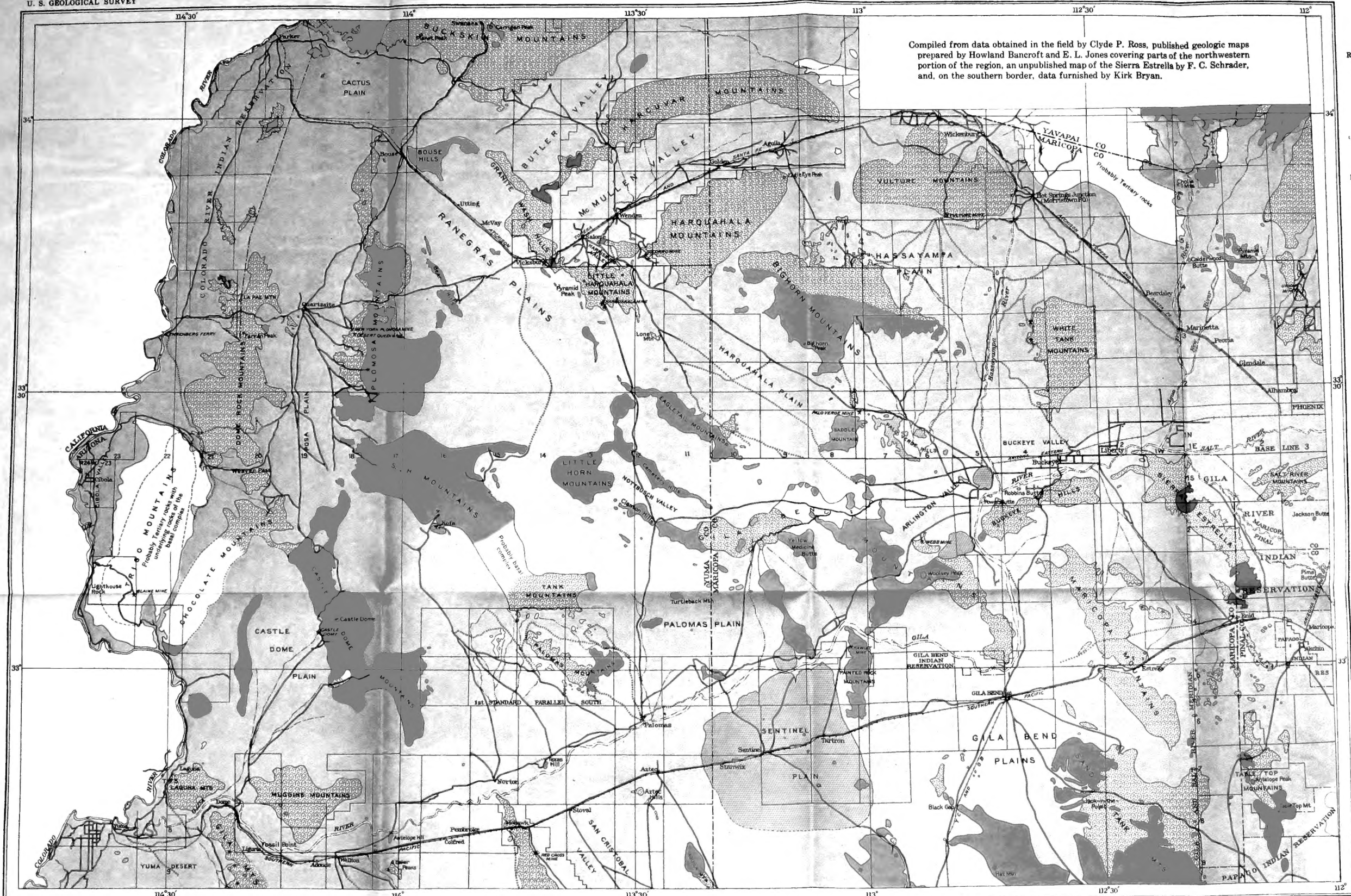

EXPLANATION

- Recent stream deposits, valley fill of unconsolidated or locally consolidated gravel and sand, and older somewhat consolidated and disturbed beds in and near the mountains.
- Basalt
(Lava flows and related intrusive plugs)
- Lava, tuff, agglomerate, and related fine-grained intrusive rocks, and subordinate amounts of sedimentary beds of arkose, sandstone, shale, and calcareous rocks.
- Granitic rocks intrusive in basal complex.
- Basal complex.
(Granitic gneiss, micaceous quartzite, arkose, and chloritic schist, metamorphosed quartzite, limestone, and dolomite - includes also small amounts of later rocks, particularly undeformed intrusives)

NOTE: White areas left uncolored for lack of information

QUATERNARY
TERTIARY
PROBABLY MESOZOIC
PRECAMBRIAN AND PALEOZOIC

RECONNAISSANCE GEOLOGIC MAP OF LOWER GILA REGION, ARIZONA.
By Clyde P. Ross

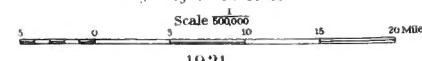

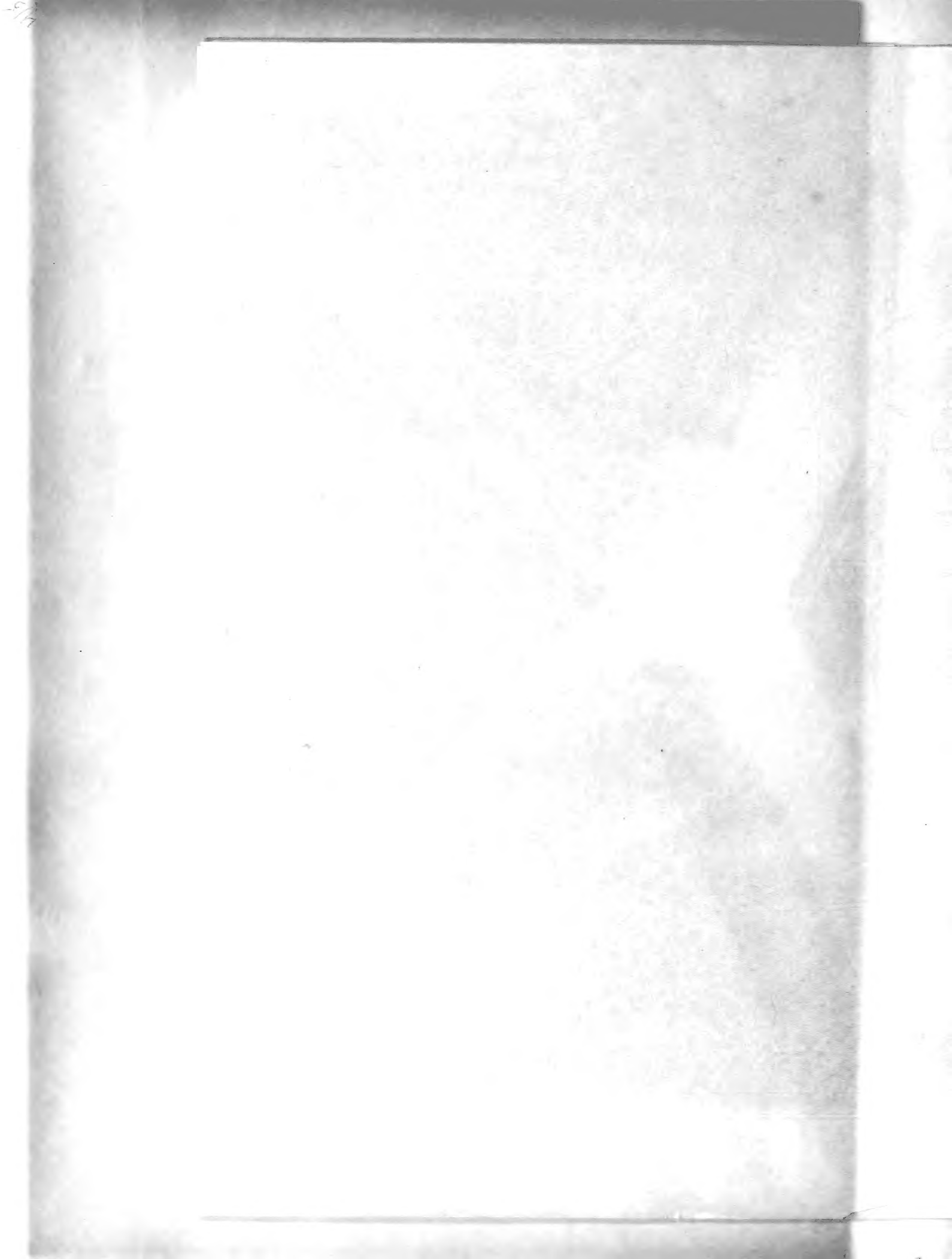



055-00603-7030