









SMITHSONIAN

27

MISCELLANEOUS COLLECTIONS

\_\_\_\_\_  
VOL. 98  
\_\_\_\_\_

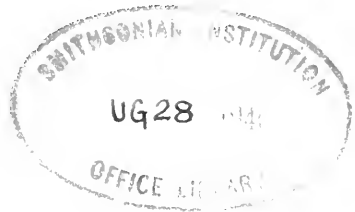

"EVERY MAN IS A VALUABLE MEMBER OF SOCIETY WHO, BY HIS OBSERVATIONS, RESEARCHES,  
AND EXPERIMENTS, PROCURES KNOWLEDGE FOR MEN"—SMITHSON

(PUBLICATION 3590)

CITY OF WASHINGTON  
PUBLISHED BY THE SMITHSONIAN INSTITUTION

1940

The Lord Baltimore Press  
BALTIMORE, MD., U. S. A.

## ADVERTISEMENT

---

The Smithsonian Miscellaneous Collections series contains, since the suspension in 1916 of the Smithsonian Contributions to Knowledge, all the publications of the Institution except the Annual Report, the annual pamphlet describing the Institution's field-work, and occasional publications of a special nature. As the name of the series implies, its scope is not limited, and the volumes thus far issued relate to nearly every branch of science. Papers in the fields of biology, geology, anthropology, and astrophysics have predominated.

C. G. ABBOT,

*Secretary of the Smithsonian Institution.*





## CONTENTS

---

1. BARTSCH, PAUL. Two remarkable new species of marine shells from Florida. 3 pp., 1 pl., Jan. 26, 1939. (Publ. 3524.)
2. CLAYTON, H. HELM. The sunspot period. 18 pp., 1 pl., 12 figs., Mar. 27, 1939. (Publ. 3526.)
3. KESSEL, EDWARD L. The embryology of fleas. 78 pp., 12 pls., May 1, 1939. (Publ. 3527.)
4. WETMORE, ALEXANDER. Five new races of birds from Venezuela. 7 pp., Mar. 10, 1939. (Publ. 3528.)
5. ABBOT, C. G. Utilizing heat from the sun. 11 pp., 4 pls., 1 fig., Mar. 30, 1939. (Publ. 3530.)
6. SCHMITT, WALDO L. Decapod and other Crustacea collected on the Presidential cruise of 1938 (with introduction and station data). 29 pp., 3 pls., 2 figs., June 15, 1939. (Publ. 3531.)
7. COOK, O. F. A new palm from Cocos Island collected on the Presidential cruise of 1938. 26 pp., 26 pls., May 29, 1939. (Publ. 3532.)
8. KILLIP, ELLSWORTH P. Flowering plants collected on the Presidential cruise of 1938. 4 pp., May 27, 1939. (Publ. 3533.)
9. TAYLOR, WM. RANDOLPH. Algae collected on the Presidential cruise of 1938. 18 pp., 2 pls., 14 figs., June 23, 1939. (Publ. 3534.)
10. BARTSCH, PAUL, and REHDER, HARALD ALFRED. Mollusks collected on the Presidential cruise of 1938. 18 pp., 5 pls., June 13, 1939. (Publ. 3535.)
11. CLARK, AUSTIN H. Echinoderms (other than holothurians) collected on the Presidential cruise of 1938. 18 pp., 5 pls., June 2, 1939. (Publ. 3536.)
12. DEICHMANN, ELISABETH. A new holothurian of the genus *Thyone* collected on the Presidential cruise of 1938. 7 pp., 3 figs., June 14, 1939. (Publ. 3537.)
13. HARTMAN, OLGA. The polychaetous annelids collected on the Presidential cruise of 1938. 22 pp., 3 figs., June 9, 1939. (Publ. 3538.)
14. GINSBURG, ISAAC. Two new gobioid fishes collected on the Presidential cruise of 1938. 5 pp., 2 figs., May 31, 1939. (Publ. 3539.)

15. DE LAUBENFELS, M. W. Sponges collected on the Presidential cruise of 1938. 7 pp., 1 fig., June 21, 1939. (Publ. 3540.)
16. MCINTOSH, ALLEN. A new microcoeliid trematode collected on the Presidential cruise of 1938. 2 pp., 1 fig., June 8, 1939. (Publ. 3541.)
17. HYMAN, LIBBIE H. Polyclad worms collected on the Presidential cruise of 1938. 13 pp., 15 figs., June 17, 1939. (Publ. 3542.)
18. STEWARD, JULIAN H. Notes on Hillers' photographs of the Paiute and Ute Indians taken on the Powell expedition of 1873. 23 pp., 31 pls., July 21, 1939. (Publ. 3543.)
19. JOHNSTON, EARL S., and WEINTRAUB, ROBERT L. The determination of small amounts of chlorophyll—apparatus and method. 5 pp., 2 pls., 2 figs., July 31, 1939. (Publ. 3545.)
20. PERRY, STUART H. The Helt Township (Indiana) meteorite. 7 pp., 9 pls., Aug. 28, 1939. (Publ. 3546.)
21. ABBOT, C. G., and McCANDLISH, N. M. The weekly period in Washington precipitation. (Roebling Fund.) 4 pp., July 27, 1939. (Publ. 3547.)
22. WETMORE, ALEXANDER. Birds from Clipperton Island collected on the Presidential cruise of 1938. 6 pp., Aug. 11, 1939. (Publ. 3548.)
23. MEIER, FLORENCE E. Stimulative effect of short wave lengths of the ultraviolet on the alga *Stichococcus bacillaris*. 19 pp., 4 pls., 1 fig., Sept. 26, 1939. (Publ. 3549.)
24. RESSER, CHARLES ELMER. The *Ptarmigania strata* of the northern Wasatch Mountains. 72 pp., 14 pls., Oct. 26, 1939. (Publ. 3550.)
25. SCHMITT, WALDO L., and SCHULTZ, LEONARD P. List of the fishes taken on the Presidential cruise of 1938. 10 pp., Jan. 4, 1940. (Publ. 3551.)





SMITHSONIAN MISCELLANEOUS COLLECTIONS

VOLUME 98. NUMBER 1

TWO REMARKABLE NEW SPECIES OF  
MARINE SHELLS FROM FLORIDA

(WITH ONE PLATE)

BY

PAUL BARTSCH

Curator, Division of Mollusks and Cenozoic Invertebrates,  
U. S. National Museum



(PUBLICATION 3524)

CITY OF WASHINGTON  
PUBLISHED BY THE SMITHSONIAN INSTITUTION  
JANUARY 26, 1939





SMITHSONIAN MISCELLANEOUS COLLECTIONS  
VOLUME 98, NUMBER 1

# TWO REMARKABLE NEW SPECIES OF MARINE SHELLS FROM FLORIDA

(WITH ONE PLATE)

BY

PAUL BARTSCH

Curator, Division of Mollusks and Cenozoic Invertebrates,  
U. S. National Museum



(PUBLICATION 3524)

CITY OF WASHINGTON  
PUBLISHED BY THE SMITHSONIAN INSTITUTION  
JANUARY 26, 1939

The Lord Baltimore Press  
BALTIMORE, MD., U. S. A.



TWO REMARKABLE NEW SPECIES OF MARINE SHELLS  
FROM FLORIDA

BY PAUL BARTSCH

*Curator, Division of Mollusks and Cenozoic Invertebrates,  
U. S. National Museum*

(WITH ONE PLATE)

There were recently brought to the attention of the United States National Museum, among other specimens, two remarkable new species of marine mollusks collected near Tarpon Springs, Fla., by Sozon Vatikiotis, a deep-sea diver. The types of these species were presented to the Museum by Mrs. Helen Vatikiotis, wife of their discoverer.

**CONUS SOZONI**, n. sp.

Plate I, figs. 1-3

Shell large and rather strong with the spire broadly conic and about one-fourth the height of the total height of the shell. The succeeding turns fall very slightly below the shoulder of the whorls and produce a feeble steplike effect on the spire. The exposed portion of the turns on the spire slopes gently and is marked by very fine obscure wrinkle-like spiral lirations and protractively curved incremental lines. From the shoulder to the tip of the base the shell is almost straight, having a slight bulge a little below the middle, and a broad feeble contraction anterior and posterior to this, which really renders the outline of the whorl slightly sinuous. The sculpture of this part of the shell consists of incremental lines of varying strength and microscopic spiral lirations, except on the basal half of the columella, which is marked by a dozen rather deep grooves that are distantly spaced posteriorly and more closely approximated anteriorly. Anteriorly they are separated by raised spiral ridges about as wide as the grooves, while posteriorly the space between the grooves becomes much wider, the last one being about five times as wide as the groove. Aperture normal, that is, we have the inner and outer lip practically parallel with a deep sinus at the posterior angle and a channel anteriorly. The color pattern of this cone is strikingly beautiful. The spire has a yellowish orange base with stretches of flesh color as a background.

It is axially marked by retractively curved brown streaks, which may be straight, curved, or zigzag. Anterior to the shoulder there is a broad band of ochraceous buff. This band covers about one-fifth of the distance between the shoulder and the tip of the columella anterior to the shoulder. It is separated by a moderately broad white zone from another broad band of the same color and width as that at the shoulder, which in turn is followed by a band about two-thirds as wide as the last mentioned of flesh color. The rest of the side grades from a little lighter than the two dark bands just mentioned to flesh color with an ochraceous flush. In addition to these major spiral dispositions of color the shell is marked by interrupted spiral bands of dark chestnut brown. The elements composing these vary considerably in size, and are best visualized by consulting our figure. Those covering the dark band immediately below the shoulder are heavier and are continuous with the dark axial zones on the spire and are almost confluent axially. The interior of the aperture is flesh-colored with a decidedly pinkish tinge, the dark pinkish flush coinciding with the darker bands.

The type, U.S.N.M. no. 472849, has 13 whorls and measures: Length, 100 mm; greater diameter, 47.5 mm. It was collected on a reef at Tarpon Springs, Fla. A paratype is in the collection of Mrs. Helen Vatikiotis. It is named for Mr. Vatikiotis, its discoverer.

**FUSINUS HELENAE, n. sp.**

Plate 1, figs. 4-5

Shell moderately large, fusiform, with the basal portion of the shell only a bit shorter than the length of the spire. The tip and early postnuclear whorls are pale chestnut brown, the rest of the shell is flesh-colored with the axial ribs rust-stained. The base and columellar portion also have rusty staining. Nuclear whorls a little more than 2, the first 1.5 turns smooth, inflated, strongly rounded, the succeeding part marked by almost vertical axial ribs. The early postnuclear whorls are marked by strong, low, broad axial ribs which are separated by equally impressed spaces of about the same width. Of these ribs, about 10 occur upon each of the first 5 turns, after which they become less conspicuous and less regular and quite inconspicuous on the last whorl. In addition to these, the whorls are marked by spiral cords, of which 5 are present on the first 3 postnuclear turns, after which they increase by intercalation, 25 varying in strength from mere threads to rather strong keels being present between summit and periphery on the last turn. Base short, strongly rounded. Columella

very long and spindle-shaped, somewhat sinuous and marked by incremental lines and rather weak spiral threads. Aperture narrowly oval in its major portion with a long, sinuous canal basally, the posterior angle is acute, outer lip thin, rendered slightly denticulated by the axial threads; inner lip thin and appressed to the columella.

This type, U.S.N.M. no. 472850, has 9.6 whorls and measures: Length, 50.4 mm; greater diameter, 14.7 mm.

I take pleasure in naming this for Mrs. Helen Vatikiotis.





1



4



2



5



3

1-3. *Conus sozoni*. 4, 5. *Fusinus helena*.

All figures are natural size except 4, which is much enlarged to show the character of the tip.









SMITHSONIAN MISCELLANEOUS COLLECTIONS  
VOLUME 98, NUMBER 2

# THE SUNSPOT PERIOD

(WITH ONE PLATE)

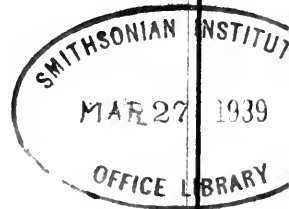

BY  
H. HELM CLAYTON



(PUBLICATION 3526)

CITY OF WASHINGTON  
PUBLISHED BY THE SMITHSONIAN INSTITUTION  
MARCH 27, 1939



SMITHSONIAN MISCELLANEOUS COLLECTIONS  
VOLUME 98, NUMBER 2

# THE SUNSPOT PERIOD

(WITH ONE PLATE)

BY  
H. HELM CLAYTON



(PUBLICATION 3526)

CITY OF WASHINGTON  
PUBLISHED BY THE SMITHSONIAN INSTITUTION  
MARCH 27, 1939

The Lord Baltimore Press  
BALTIMORE, MD., U. S. A.

# THE SUNSPOT PERIOD

BY H. HELM CLAYTON

(WITH ONE PLATE)

## PREFACE

The objects of this paper are :

1. To show that the smoothed plus and minus annual departures from normal pressure observed in the earth's atmosphere are displaced in position in unison with variations in intensity of sunspot maxima.

2. To show that the annual sunspot numbers may be resolved into a number of regular periods of constant length and amplitude which, when combined, make the irregular sunspot period and permit forecasting, with reasonable accuracy, the dates of maxima and minima of sunspots and the intensity of the maxima.

## ATMOSPHERIC PRESSURE AND THE SUNSPOT PERIOD

Atmospheric pressure is subject to large fluctuations of short period, especially in high latitudes. In order to study long-period oscillations like those of sunspot numbers, it is necessary to smooth out the short-period fluctuations, just as it is necessary to smooth out the wind-driven waves in the ocean in order to study the tides.

This smoothing is frequently done by numerical averaging. Such averages block out the oscillations of short period but do not eliminate long-period trends in the data nor oscillations much longer than the ones it is desired to study. Smoothing by harmonic formulas is therefore believed to be the best method, because by such smoothing one can eliminate oscillations which are much longer as well as those which are much shorter than those which it is desired to study.

The type of harmonic formula used for this purpose is as follows: Let  $l_0, l_1, l_2, l_3, \dots, l_{n-1}$  be observed values which are associated with equidistant values of some argument, say time; then the single

periodic terms, namely, coefficients of a sine curve drawn through the observations, may be represented by the trigonometrical formulæ:

$$L = A_0 + A_1 \cos \phi + B_1 \sin \phi, \quad (1)$$

in which

$$A_0 = \frac{\sum l}{n}, \quad (2)$$

$$A_1 = \frac{\sum l \cos \phi}{\frac{1}{2}n}, \quad (3)$$

$$B_1 = \frac{\sum l \sin \phi}{\frac{1}{2}n}, \quad (4)$$

$$\frac{A_1}{B_1} = \tan \theta, \quad (5)$$

$$a = \sqrt{A_1^2 + B_1^2} = \frac{A_1}{\sin \theta} \quad (6)$$

$$\phi = \frac{360^\circ}{n}; \quad (7)$$

where  $\theta$  = angle of the epoch, namely, the angular distance from zero to the part of the sine curve at the beginning of the period, and  $a$  = amplitude, while  $n$  = number of terms used.

The method of computation is shown in table 1. In this table the normal monthly temperatures at New York, derived from 50 years of observations, are used, and the coefficients of a sine curve passing through them are computed. From these coefficients, monthly values are then computed and are given at the bottom of the table. It is seen that these differ very little from the observed values, showing that these observed values follow very nearly a sine curve.

The computed values for each month may, however, be obtained in a different way, as shown in table 2. In this table the normal monthly temperatures at New York are multiplied by the cosine values given in column 3 of table 1. The cosine values are slipped down 1 month at a time, and the sum of the products in each case divided by 6 gives the value on a sine curve for the month in which the cosine value is unity.

For example, in the first column of products the cosine is unity in January and the sum of all the products divided by 6 is  $-21.7$ , the same as the computed value in table 1 when  $A_0 = 0$ . In the second column of products the cosine unity is placed in February, and the sum of the products divided by 6 is  $-20.7$ ; and so on successively

for each month. These are nearly identical with the computed values in table 1 when  $A_0 = 0$ . The small differences that exist are accounted for by the fact that the cosine factors were only taken to two or three decimals instead of to four or more. The successive values are thus equivalent to those of moving means except that the smoothing is done by harmonic terms instead of numerically.

TABLE 1.—*Example computation by harmonic formula*

Cycle of 360° divided into 12 parts	Sine values	Cosine values	Normal monthly tempera- tures, New York <sup>a</sup>		Temperatures—	
					By sine values	By cosine values
(1)	(2)	(3)	(4)	(5) ° F.	(6) ° F.	(7) ° F.
0° . . . . .	0.00	1.00	January . . . . .	30.6	0.0	30.6
30° . . . . .	0.50	0.866	February . . . . .	30.5	15.3	26.4
60° . . . . .	0.866	0.50	March . . . . .	38.0	32.9	19.0
90° . . . . .	1.00	0.00	April . . . . .	48.5	48.5	0.0
120° . . . . .	0.866	-0.50	May . . . . .	59.4	51.4	-29.7
150° . . . . .	0.50	-0.866	June . . . . .	68.5	34.3	-59.3
180° . . . . .	0.00	-1.00	July . . . . .	73.5	0.0	-73.5
210° . . . . .	-0.50	-0.866	August . . . . .	72.1	-36.1	-62.4
240° . . . . .	-0.866	-0.50	September . . . . .	66.4	-57.5	-33.2
270° . . . . .	-1.00	-0.00	October . . . . .	55.8	-55.8	0.0
300° . . . . .	-0.866	0.50	November . . . . .	44.1	-38.2	22.1
330° . . . . .	-0.50	0.866	December . . . . .	34.3	-17.2	29.7
Sum . . . . .	0.00	0.00		...	-22.4	-130.3

*Monthly values computed from  $\theta$  and  $a$* 

	Jan.	Feb.	Mar.	Apr.	May	June
For $A_0 = 0$ . . . . .	-21.7	-20.7	-14.1	-3.8	7.6	17.0
For $A_0 = 51.8$ . . . . .	30.1	31.1	37.7	48.0	59.4	68.8
	July	Aug.	Sept.	Oct.	Nov.	Dec.
For $A_0 = 0$ . . . . .	21.7	20.7	14.1	3.8	-7.6	-17.0
For $A_0 = 51.8$ . . . . .	73.5	72.5	65.9	55.6	44.2	34.8

<sup>a</sup> Mean of 51 years, 1873-1923.

$$a = \frac{1}{2} \sqrt{(22.4)^2 + (130.3)^2} = 22.04; \tan \theta = \frac{130.3}{22.4} = 5.81; \theta = 260^\circ.$$

$\theta$  = epoch;  $a$  = amplitude;  $A_0 = 51.8$  = Mean for year.

The same results are obtained by the correlation formulas as is shown by the computations in table 3.

A cosine curve has the form exhibited in figure 1. Observed data are multiplied by a cosine series representing such a curve and the process repeated step by step, adding one unit of time and dropping one. If the length of the cosine series is near the length of any period which may exist in the observed data, that period will stand out prominently. The process eliminates periods of much smaller and

TABLE 2.—*Temperatures multiplied by cosine values*

	(1)	(2)	(3)	(4)	(5)	(6)	(7)	(8)	(9)	(10)	(11)	(12)
Normal monthly temperatures at New York <sup>a</sup>	30.6	30.6	...	...	...	...	...	...	...	...	...	...
January	30.6	30.6	...	...	...	...	...	...	...	...	...	...
February	26.4	30.5	...	...	...	...	...	...	...	...	...	...
March	19.0	32.9	38.0	...	...	...	...	...	...	...	...	...
April	8.5	24.3	42.0	48.5	...	...	...	...	...	...	...	...
May	59.4	0.0	29.7	51.4	59.4	...	...	...	...	...	...	...
June	68.5	-34.3	0.0	34.3	59.3	68.5	...	...	...	...	...	...
July	73.5	-63.7	-36.8	0.0	36.8	63.7	73.5	...	...	...	...	...
August	72.1	-62.4	-62.4	-36.1	0.0	36.1	62.4	72.1	...	...	...	...
September	66.4	-33.2	-57.5	-66.4	-33.2	0.0	33.2	57.5	66.4	...	...	...
October	55.8	-27.9	-48.3	-55.8	-48.3	-27.9	0.0	27.9	48.3	55.8	...	...
November	44.1	22.1	0.0	-22.1	-38.2	-44.1	-22.1	0.0	22.1	38.1	44.1	...
December	34.3	20.7	17.2	0.0	-17.2	-20.7	-17.2	-17.2	0.0	17.2	20.7	34.3
January	30.6	...	26.5	15.3	0.0	-15.3	-26.5	-26.5	-15.3	0.0	15.3	26.5
February	30.5	...	...	26.4	0.0	-15.3	-26.4	-30.5	-26.4	-15.3	0.0	15.3
March	38.0	...	...	...	32.9	19.0	-19.0	-32.9	-38.0	-32.9	-19.0	0.0
April	48.5	...	...	...	...	42.0	0.0	-24.3	-48.5	-42.0	-19.0	-24.3
May	59.4	...	...	...	...	51.4	29.7	0.0	-29.7	-51.4	-59.4	-51.4
June	68.5	...	...	...	...	...	59.3	34.3	0.0	-34.3	-68.5	-68.5
July	73.5	...	...	...	...	...	...	63.7	36.8	0.0	-36.8	-63.7
August	72.1	...	...	...	...	...	...	...	62.4	36.1	0.0	-36.1
September	66.4	...	...	...	...	...	...	...	...	57.5	33.2	0.0
October	55.8	...	...	...	...	...	...	...	...	...	48.3	27.9
November	44.1	...	...	...	...	...	...	...	...	...	...	38.2
December	34.3	...	...	...	...	...	...	...	...	...	...	...
Sums	-130.3	-124.3	-84.6	-22.4	45.9	101.8	130.3	124.2	84.6	22.3	-45.9	-101.8
Means, $\frac{1}{6}$ of sums	...	-20.7	-14.1	-3.7	7.6	17.0	21.7	20.7	14.1	3.7	-7.6	-17.0
Observed	...	-21.2	-13.8	-3.3	7.6	16.7	21.7	20.3	14.6	4.0	-7.7	-17.5

<sup>a</sup> Averages of 51 years, 1873-1923.



TABLE 3.—*Harmonic terms computed by correlations*

(1)	(2)	(3)	(4)	(5)	(6)
Month	$x = \text{cosine values}$	$y = \text{temperature departures}$	$xy = \text{product}$	$x^2$	$y^2$
July .....	1.00	21.7	21.7	1.00	471
August .....	.866	20.3	17.6	.75	412
September .....	.50	14.6	7.3	.25	213
October .....	.00	4.0	.0	.00	16
November .....	-.50	-7.7	3.8	.25	136
December .....	-.866	-17.5	15.1	.75	306
January .....	-1.00	-21.2	21.2	1.00	449
February .....	-.866	-21.3	18.4	.75	454
March .....	-.50	-13.8	6.9	.25	190
April .....	.00	-3.3	.0	.00	44
May .....	.50	7.6	3.8	.25	134
June .....	.866	16.7	14.5	.75	279
Sums .....	.00	.0	130.3	6.00	3104

$$\text{Correlation coefficient } r = \frac{\sum xy}{\sqrt{\sum x^2 \sum y^2}} = \frac{130.3}{\sqrt{6 \times 3104}} = \frac{130.3}{136.8} = 0.95$$

$$a = \frac{\sum xy}{\sum x^2} = \frac{130.3}{6} = 21.7$$

NOTE.— $a$  = ratio of the observed values to a cosine series having plus unity in July and minus unity in January.

much greater lengths than the cosine series and shows no consistent period of any length when treating random data.

For example, if we multiply the monthly mean temperatures at New York City by a cosine series of 12 terms, beginning with any

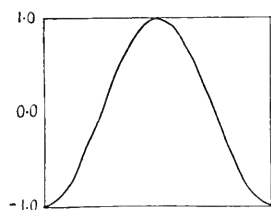

FIG. 1.—A cosine series.

given month, and repeat the process month by month, adding 1 month and dropping 1, taking the mean values in each case, the results will show regular periodic oscillations of 12 months in length. The mean is obtained by dividing the successive sums by  $\frac{1}{2}n$ ,  $n$  being the number of terms used. The time is taken at the middle of the series. Figure 2 shows a plot of the annual period in temperature at New York obtained in that manner from 1927-1929. This plot shows that the

annual period in temperature at New York is approximately constant in phase from year to year and nearly constant in amplitude.

If next a trial for shorter periods is made, it is found that when a cosine series of 24 terms is multiplied by the observed hourly temperatures, a period of 24 hours stands out prominently. Figure 3 shows the daily period in temperature obtained from hourly observations of temperature at Blue Hill Observatory, near Boston, Mass. This plot shows that the maxima and also the minima of temperature

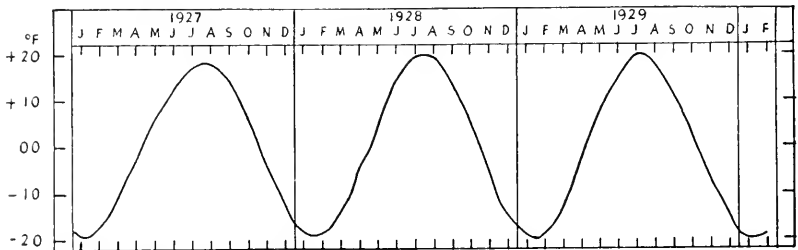

FIG. 2.—Monthly temperatures at New York, smoothed harmonically.

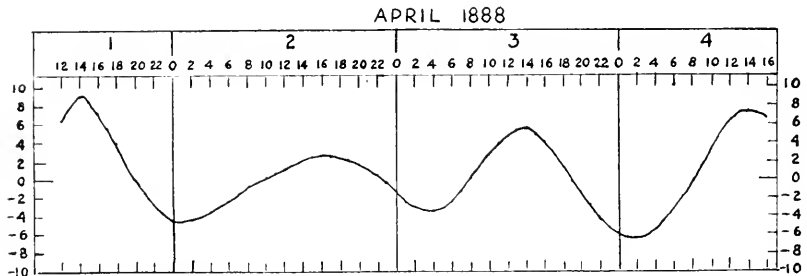

FIG. 3.—Hourly temperatures at Blue Hill, smoothed harmonically.

occur near the same hours every day, but that the period is very variable in amplitude. Further research shows that this period occurs only in the lower atmosphere and that the oscillations are large when the sky is clear and small when there are dense clouds. Hence, its variability in amplitude is closely related to moisture and cloudiness.

Yearly means of atmospheric pressure, when treated in the same manner, show clearly defined oscillations of 10 to 12 years. In figure 4, the result of analyzing the pressure at Stykkisholm, Iceland, with a 12-term series is shown by a continuous line and is compared with a plot of yearly sunspot numbers shown by a dotted line.

The sunspot curve shows a fairly regular period which averages about 11 years, but varies in length and amplitude.

The curve for Stykkisholm is an interesting type. In 1870 and again in 1917, it shows maxima which coincide with the sunspot maxima while from 1875 to 1909 the oscillations are the reverse of the sunspot oscillations. Here then is a period whose maxima and minima coincide approximately in time with those of the sunspots but invert in phase from time to time. In the Bulletin of the American Meteorological Society for July 1938, page 218, it was shown that this inversion in phase was caused by a change in latitude of the departures from normal pressure with an increase of solar activity (see fig. 5). To obtain the lines of equal departure shown on these charts the pressures at more than 200 stations were smoothed in the same way as those of Stykkisholm.

However, the atmosphere does not oscillate back and forth between the centers of plus and minus departures with a fixed zero line

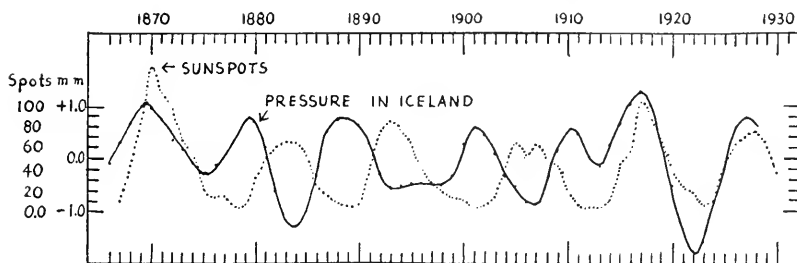

FIG. 4.—Smoothed annual pressures and sunspot numbers.

between them, as might be thought on examining the charts in figure 5, but there occurs a gradual shift of the centers of excess and defect of pressure. This process is illustrated by the curves in figures 6 and 7. It is seen from the first series of curves in figure 6 that, at the time of sunspot maximum in 1917, a barometric maximum existed in high latitudes over the North Atlantic, as shown by the pressures at Jacobs-havn and at Stykkisholm. At stations farther south this maximum occurred successively later, until in the latitude of Madeira the pressure oscillated nearly inversely to that of the sunspots. The same conditions apparently occurred in the North Pacific, as shown by the second series of curves in figure 6. The stations are situated near the Pacific Coast of North America. At Tanana the maximum of pressure occurred nearly at the time of sunspot maximum, but came successively later at lower latitudes, until at San Diego the curve is nearly inverse to the sunspot curve.

On the other hand, over low latitudes on or near the central continental masses of North America and Asia a minimum of pressure

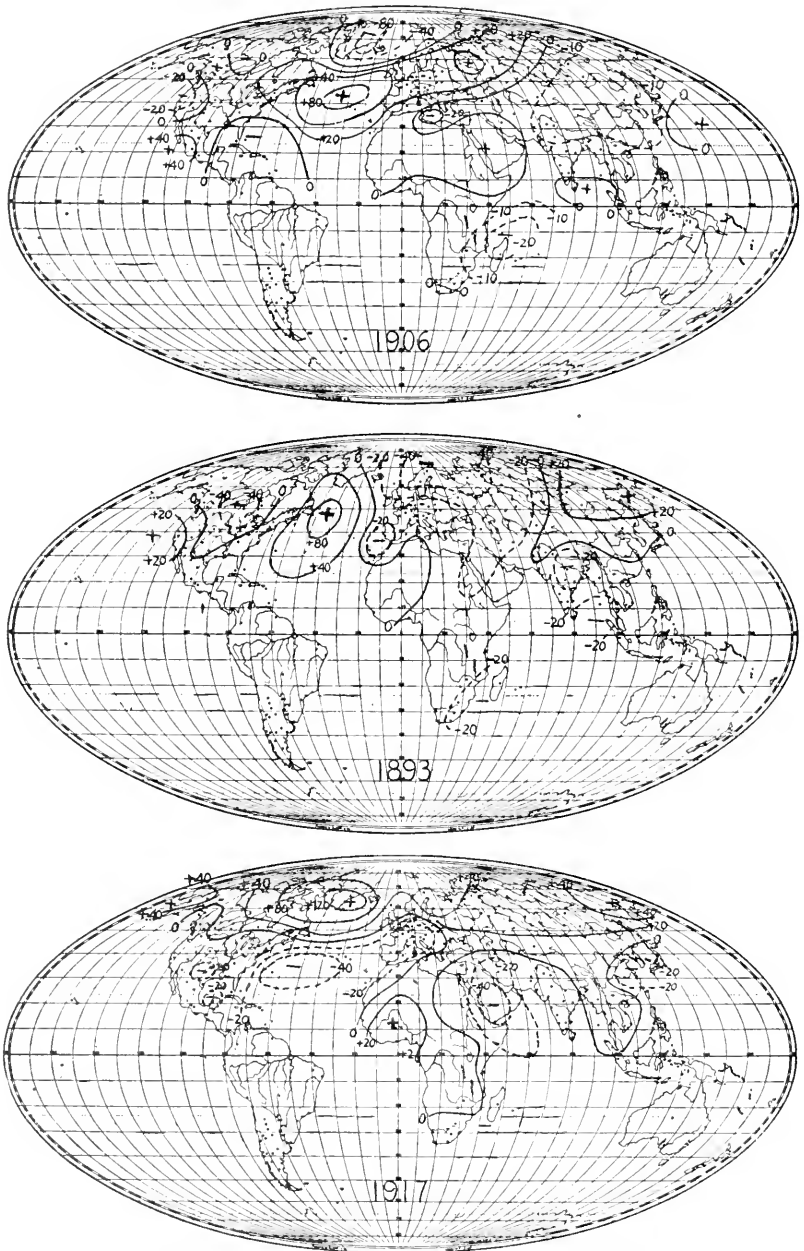

FIG. 5.—Atmospheric pressure at maxima of sunspots, 1906, 1893, 1917.  
(Units 0.01 mm.)

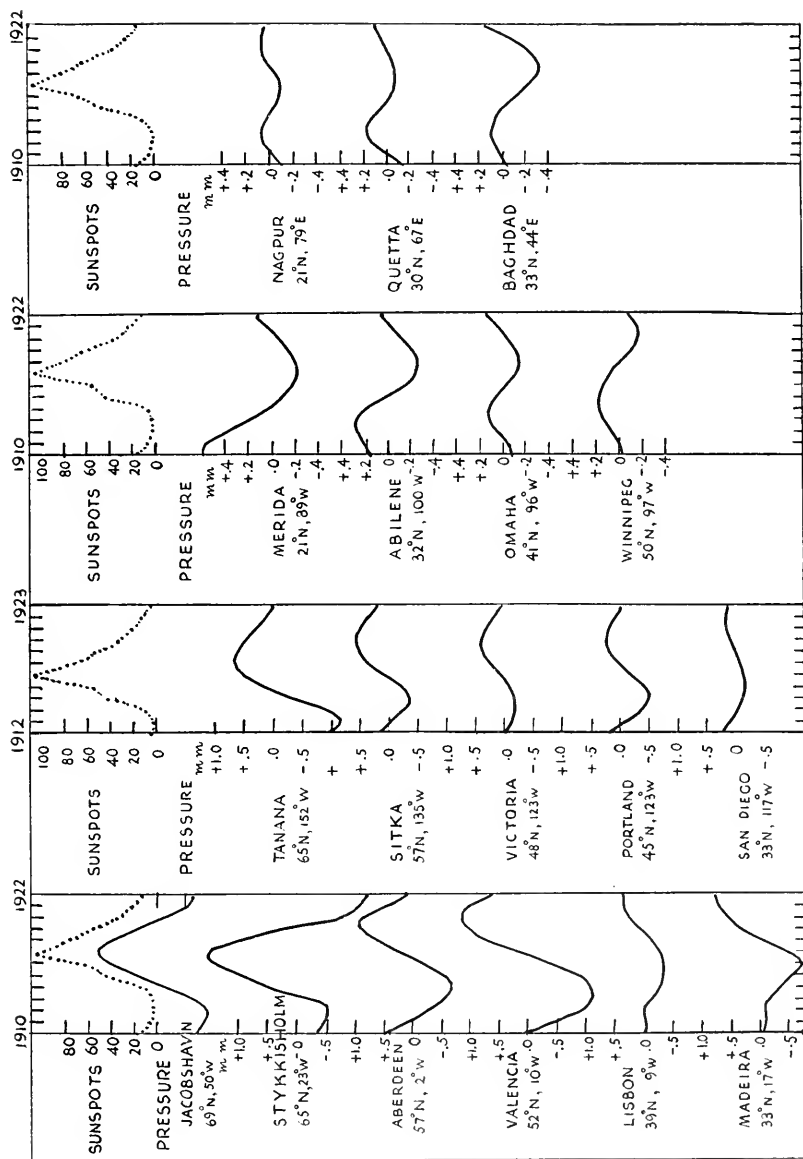

FIG. 6.—Sunspot maximum of 1917 and atmospheric pressure.

occurred about the time of sunspot maximum and apparently moved northward, at least as far as latitude  $40^{\circ}$ – $50^{\circ}$ . This condition is shown by the third and fourth series of curves in figure 6.

At the time of the less intense solar maximum of 1906 the maxima of pressure were found in latitudes  $40^{\circ}$ – $50^{\circ}$  N. over the oceans as shown in figure 5 and apparently moved from west to east, figure 7.

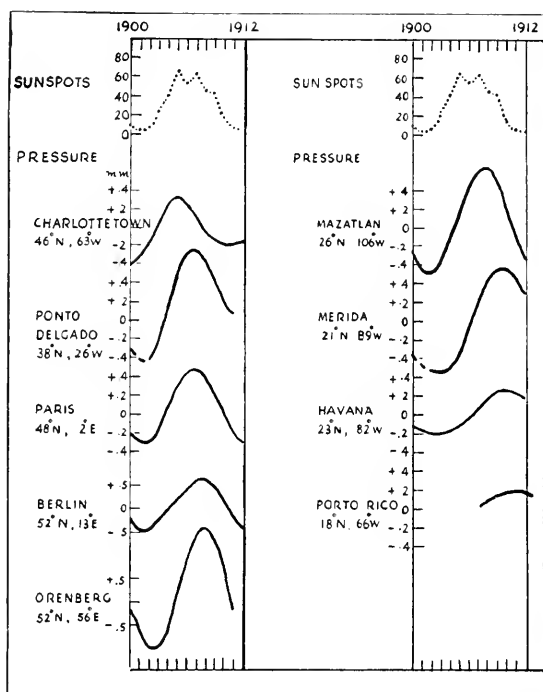

FIG. 7.—Sunspot maximum of 1906 and atmospheric pressure.

Hence, not only the positions of the areas of excess and defect of pressure are determined by the intensity of solar activity, but also the direction of the subsequent movement of these areas. The names *baroplions* and *baromions* have been suggested for these areas.

A cosine series used in the way described above does not necessarily give a period of its own length. If the monthly mean temperatures at New York had been analyzed by a cosine series of 11 terms covering 11 months instead of 12, the resulting curve would have been exactly the same as that shown in figure 2, except that the amplitude would have been somewhat reduced. The same is true had the cosine series contained 13 terms covering 13 months instead of 12. In each case

the period shown would have been exactly the 12-months' period which exists in nature. The ordinary process of harmonic analysis gives the elements of a fixed period which is assumed in advance, but the process described above gives any period which may exist in the data near the length of the assumed period. The true length of the period is determined by the average length of the interval between the maxima and minima shown by the analysis.

In the case of cosine analysis of random data the maxima and minima occur at irregular intervals and the average amplitude approxi-

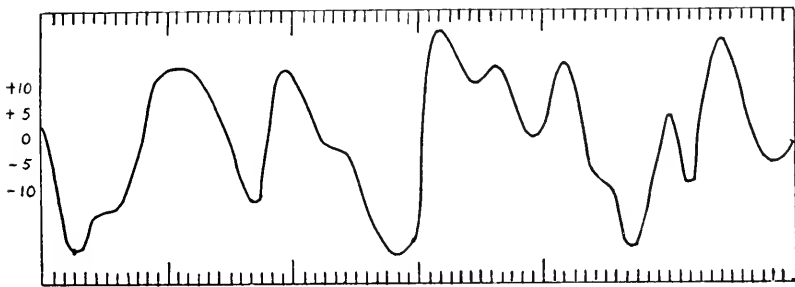

FIG. 8.—Some random data, smoothed harmonically.

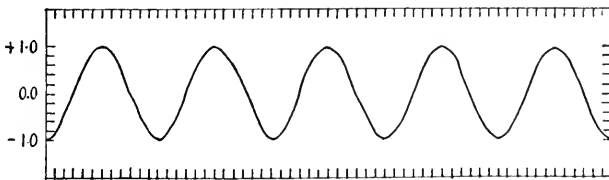

FIG. 9.—A sequence of 5 cosine curves.

mates zero. A plot of a series of random numbers smoothed harmonically is given in figure 8. These were treated by the same method as were the monthly temperatures at New York (see fig. 2) and the yearly pressures at Stykkisholm (see fig. 4). The curve in figure 8 shows large oscillations but no evidence of periodicity.

When evidence of periodicity is found it can usually be separated from random oscillations by obtaining means of three, five, or more successive periods.

In case the amplitudes of the periodic terms are relatively small, it is desirable, in order to bring out the periodic term clearly, to repeat the cosine series several times consecutively. When plotted, these successive series have the form of waves, as shown in figure 9.

Observed data are multiplied by such a series of 3, 5, or 10 waves, mean values are obtained, and the process is repeated by dropping one

unit of time and adding another. In this way, whenever there is a period in the observed data near the period of the cosine waves, it is separated from chance variations and from periods of other length so as to stand out prominently in a plot of the results of the computations. The numerical work is like that shown in column 7 of table 1 repeated several times consecutively, or else the values are treated as shown in table 3. In this table column 1 contains the numbers which, when plotted, form a curve like that in figure 9. These numbers are then correlated with numbers representing sunspots, solar radiation, atmospheric pressure, or other physical quantity. If the correlation is sufficiently high, a period of the approximate length of the cosine

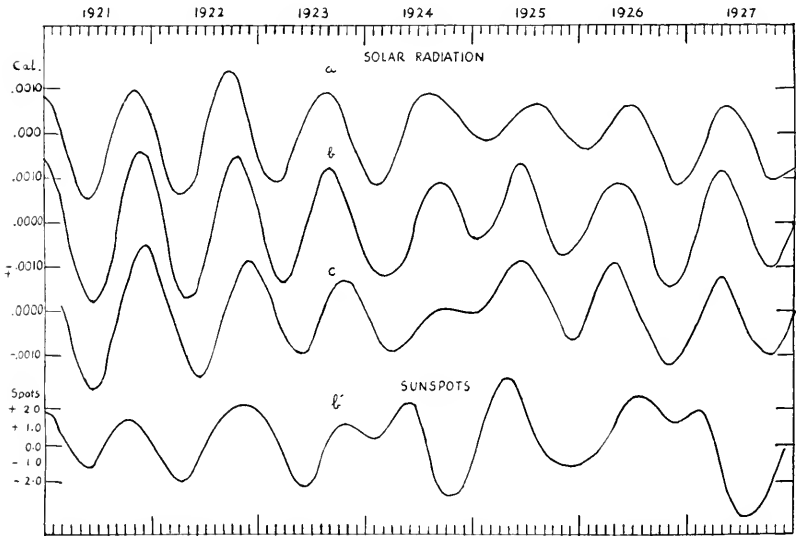

FIG. 10.—Eleven-month period in solar radiation and sunspots.

waves in column 1 is indicated. Then, if successive values of  $a$  (commonly called the regression coefficient) are computed, the numbers when plotted give curves like that shown in figures 10 and 11. In other words, whether the data are treated by the harmonic formulas or by the correlation formulas, the same results are obtained. Since the correlation formulas are in general use, it will perhaps be easier for most readers to understand the problem as one of correlation. Physicists to whom I presented the method understood it better in that way.

The monthly mean values of solar radiation obtained by the Astrophysical Observatory of the Smithsonian Institution were treated in this manner, and the results are plotted in three curves  $a$ ,  $b$ , and  $c$  in figure 10.



Curve *a* was obtained from 5 consecutive cosine waves, each covering 10 units of time, curve *b* from 5 consecutive cosine waves, each covering 11 units of time and curve *c* from 5 waves each covering 12 units of time.

Each curve shows recurrent maxima and minima at intervals of about 11 months. Hence, it is evident that the length of the cosine series does not have to be exactly of the same length as the hidden

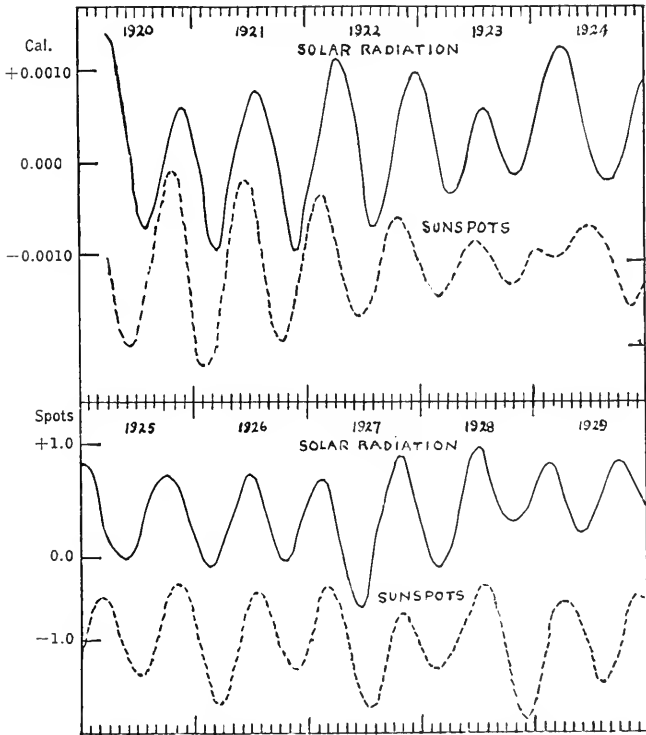

FIG. 11.—Eight-month period in solar radiation and sunspots.

period in order to disclose it, but only approximately of the same length. The cosine waves of 10 units of time do not produce a 10-months' period, and the series of 12 does not produce a 12-months' period.

When the monthly sunspot numbers from Zurich are treated in this same manner with an 11-term series, there are found oscillations similar in length and form to those found for solar radiation (see curve *b'*), but the oscillations are not quite so regular. The maxima of spots occur nearly at the same time as the maxima of solar radiation.

The monthly means of solar radiation and the monthly sunspot numbers were next multiplied by a cosine series of five waves each of eight terms; the resulting means, when plotted, give curves like those shown in figure 11. Both curves show a period of about 8 months during the years 1920-1929. The maxima in the two curves differ slightly in time, the solar radiation maxima being occasionally slightly behind and at other times slightly ahead of the spot maxima; but in the average the two are simultaneous, the greater amount of solar radiation coming at the same time as the maxima of spots.

These periods of about 11 months and 8 months are the same as those found by Dr. C. G. Abbot in the monthly means of solar radiation. In addition figures 10 and 11 show that there exist similar periods in the monthly sunspot numbers coinciding in phase with the solar radiation.

These periods are not exactly 11 months and 8 months in length. They appear to be about one-twelfth and one-sixteenth respectively of the sunspot period of 11.17 years or 134 months.

The analogy nearest to the process described is found in the phenomena of sound. Certain physical objects, as for example, a taut wire, respond only to sound waves of one rate of vibration or to waves near that length. If waves of increasing length or rates of vibration are sounded, the object will begin to respond with vibrations when the key note of the object is approached and will show strong response when the key note is reached. Changes in physical state may thus be studied; a glass tumbler will emit one key note when it is empty and a different note when it is partially filled with water.

In a similar manner changes in atmospheric conditions may be studied by a succession of cosine waves, such for example as the diurnal waves of temperature which have a large amplitude when the sky is clear and a lesser amplitude when it is cloudy.

The method of computation described here in the search for hidden periodicities is slow and tedious, but efforts are in progress to perfect a machine which will do the work more rapidly and more accurately. The machinery consists of a Coradi harmonic analyzer, and a Ferguson universal pantograph which permits changing the horizontal time scale to fit the analyzer without changing the vertical scale of quantity. In this manner any series of harmonic waves of whatever length may be mechanically integrated and the plot advanced step by step until the entire curve is covered.

Observed data are analyzed with this mechanism and the results, when plotted, disclose any hidden periodicity near the length of the

cosine series of harmonic waves. Plate I shows a photograph of these instruments arranged for use.

Analysis by this method brings out the hidden periods both in length and amplitude and discloses any changes which take place in phase or amplitude.

#### ANALYSIS OF THE SUNSPOT NUMBERS

The sunspot period is one of those periods in nature which vary in length and in intensity. The question arises whether these variations are capable of being analyzed into a number of regular periods which can be extended into the future, as are the tidal fluctuations, or whether the sunspots are due to irregular explosions in the sun which cannot be resolved into regular periods.

To test this question, the sunspot numbers published at Zurich were subjected to an analysis by the method outlined in the preceding pages. The method was applied to the sunspot data in order to see whether they could be analyzed into regular periods of different lengths which could be used to predict the times and intensity of maxima and minima of sunspots. The results are very encouraging.

The first analysis indicated a fundamental sunspot period of 11.35 years which was modified by other periods, several of which tend to coincide with the fundamental period every 68 years.

In obtaining these periods, all the sunspot data from 1749 to 1936 were used. The data preceding 1793 were, however, meager and are given little weight by the directors of the Zurich Observatory, who are responsible for the collection. Beginning the analysis with the more trustworthy data in 1793, the fundamental sunspot period becomes 11.17 years.

The length and amplitude of the secondary periods in sunspots were determined in two ways, first, directly from the observed annual means; and, second, from the residuals after determining the average, or normal value, for each year of the 11.17-year fundamental period and subtracting these normals from the observed data, thus approximately or entirely eliminating the influence of that period.

These secondary periods have an amplitude much less than the fundamental period, but the amplitude increases as the length of the period approaches that of the fundamental period. The periods of 9.93 and 11.9 have amplitudes nearly half that of the fundamental period.

The length and amplitudes of the periods found were as follows :

TABLE 4.—*Sunspot periods by harmonic analysis*

Length	Amplitude
5.56 years	4 spots
8.12 "	6 "
8.94 "	10 "
9.93 "	13 "
11.17 "	35 "
11.90 "	15 "
14.89 "	9 "
19.86 "	4 "

It is believed that this method of analysis gives the lengths and amplitudes of these periods with more accuracy than has been attained heretofore, but it is of interest to compare the results with the periods derived by other methods of analysis by various research workers. This comparison is given in table 5.

TABLE 5.—*Length of sunspot periods in years found by various research workers*

A. Schuster (1906).....	4.8	...	...	8.4	...	...	11.13	13.5	...	...
K. Stumpff (1928).....	...	5.6	7.3	...	8.8	10.0	11.13	12.9	14.3	20.5
A. E. Douglass (1936).....	...	...	...	...	8.5	10.0	11.4	13.5	14.3	...
D. Alter (1928).....	...	...	7.6	8.1	8.7	10.0	11.37	...	14.0	21.0
H. H. Clayton (1938).....	...	5.6	...	8.1	8.9	9.9	11.17	11.9	14.9	19.9

The analysis of Schuster and Stumpff was made by means of the Schuster periodogram, the analysis by Alter<sup>1</sup> was derived from the correlation periodogram, and the analysis by Douglass<sup>2</sup> was made with an ingenious instrument which he calls a cyclogram.

It is interesting to note how well these periods by different workers agree with each other, especially the periods between 8.1 and 14.9 years. The most marked discrepancy is in the periods of about 12 to 13.5 years, but here there are probably two periods, one of 11.9 years and another of about 13 years. It is also of interest to note that most of them are near submultiples of a period of about 89.36 years, a period which is shown in tables 6 and 7 and in figure 12 to give very closely the sunspot maxima and minima for more than 300 years. It seems clear that if there are a number of periods combining to make

<sup>1</sup> Alter, D., A new analysis of sunspot numbers. Monthly Weather Rev., vol. 56, p. 399, Oct. 1928.

<sup>2</sup> Douglass, A. E., A study of cycles, p. 129. Carnegie Inst. of Washington, 1936.

the yearly sunspot numbers, then these periods are approximately of the length and amplitude given in table 4.

From scattered observations of sunspots in the past three centuries a table was made at the Zurich Observatory by Wolf and Wolfer giving the approximate time of maxima and minima of spots from 1610 to the beginning of regular observations.

In order to test whether a period of 89.36 years could be used in determining the dates of these maxima and minima, going backward from observed maxima and minima between 1856 and 1933, tables 6 and 7 were constructed. Table 6 gives the computed and observed minima of spots, and table 7 gives the computed and observed maxima of spots.

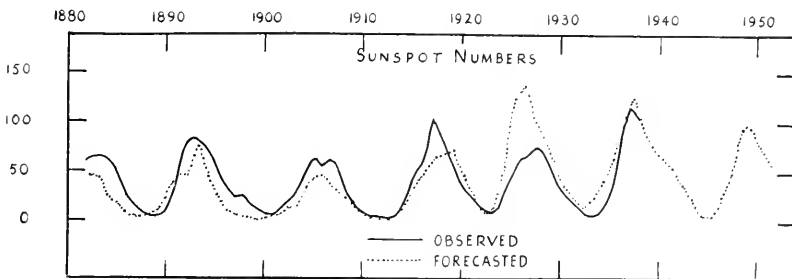

FIG. 12.—Sunspot numbers forecasted and observed.

Only a few of Wolfer's estimated dates of minima and maxima of sunspots from 1610 to 1850 differ greatly from the computed values given in the table, and these few were not assigned a weight exceeding 2 on a scale of 10 in Wolfer's table.

The next step was to try how nearly the 89.36-year period could be used in forecasting recent sunspot periods. Beginning with the minimum of 1798, for which a weight of 8 on a scale of 10 was assigned in Wolfer's table, the sunspot numbers were projected forward 89.36 years in time and compared with observed values. This comparison is given in figure 12. It will be seen from this figure that the projected curve, shown by the dotted line, gives a good forecast of the dates of observed maxima and minima of sunspots, shown by the full curve, for the interval of 55 years, 1883-1937, and gives an approximation to the intensity of the maxima, excepting the one in 1928. From this showing it is a reasonable inference that a similar accuracy can be obtained for 89.4 years in the future.

The dotted curve is projected forward to 1950 and indicates the next minimum of sunspots in 1945 and the next maximum in 1949.

This forecast is evidently more accurate than simply projecting each maximum and minimum 11 years ahead as it occurs.

A still more accurate forecast probably can be made by a separate combination of all the periods. This combination will be tried when the amplitude and phase of each period are determined with the greatest accuracy possible from existing data.

TABLE 6.—*Sunspot minima*

Observed minima	Computed			Wolfer's estimated dates of occurrence		
	89.36 years	178.72 years	268.08 years	Date	Date	Date
	Date	Date	Date			
1933.8	1844.4	1755.1	1665.7	1843.5	1755.2	1666.0
1923.6	1834.2	1744.9	1655.5	1833.9	1745.0	1655.0
1913.6	1824.2	1734.9	1645.5	1823.3	1734.0	1645.0
1901.7	1812.3	1723.0	1633.6	1810.6	1723.5	1634.0
1889.6	1800.2	1710.9	1621.5	1798.3	1712.0	1619.0
1878.9	1789.5	1700.2	1610.8	1784.7	1698.0	1610.8
1867.2	1777.8	1688.5	.....	1775.5	1689.5	.....
1856.0	1766.6	1677.3	.....	1766.5	1679.5	.....

TABLE 7.—*Sunspot maxima*

Observed maxima	Computed			Wolfer's estimated dates of occurrence		
	89.36 years	178.72 years	268.08 years	Date	Date	Date
	Date	Date	Date			
1928.4	1839.0	1749.7	1660.3	1837.2	1750.3	1660.0
1917.6	1828.2	1738.9	1649.5	1829.9	1738.7	1649.0
1906.4	1817.0	1727.7	1638.3	1816.4	1727.5	1639.5
1894.1	1804.7	1715.4	1626.0	1805.2	1718.2	1626.0
1883.9	1794.5	1705.2	1615.8	1788.1	1705.5	1615.5
1870.6	1781.2	1691.9	.....	1778.4	1693.0	.....
1860.1	1770.7	1681.4	.....	1769.7	1685.0	.....
1848.1	1758.7	1669.4	.....	1761.5	1675.0	.....

In view of the fact that the sunspot period is becoming important in numerous fields of scientific activity, much significance attaches to the forecasting of the time and intensity of the maxima and minima.

Prof. S. P. Fergusson made the necessary adjustments and modifications of the instruments illustrated in plate 1, and Miss M. I. Robinson assisted in the computations needed in the preparation of this treatise.



ANALYZER AND PANTOGRAPH





SMITHSONIAN MISCELLANEOUS COLLECTIONS  
VOLUME 98, NUMBER 3

SMITHSONIAN INSTITUTION  
MAY 1 1939  
GEN. LIBRARY

# THE EMBRYOLOGY OF FLEAS

(WITH 12 PLATES)

BY  
EDWARD L. KESSEL  
University of San Francisco



(PUBLICATION 3527)

CITY OF WASHINGTON  
PUBLISHED BY THE SMITHSONIAN INSTITUTION  
MAY 1, 1939



SMITHSONIAN MISCELLANEOUS COLLECTIONS  
VOLUME 98, NUMBER 3

# THE EMBRYOLOGY OF FLEAS

(WITH 12 PLATES)

BY  
EDWARD L. KESSEL  
University of San Francisco



(PUBLICATION 3527)

CITY OF WASHINGTON  
PUBLISHED BY THE SMITHSONIAN INSTITUTION  
MAY 1, 1939

*The Lord Baltimore Press*  
BALTIMORE, MD., U. S. A.

# THE EMBRYOLOGY OF FLEAS

By EDWARD L. KESSEL

*University of San Francisco*

(WITH 12 PLATES)

## INTRODUCTION

Aside from its general scientific aspects, the study of flea embryology is of interest from two particular standpoints. In the first place, such an investigation has been needed to extend our knowledge of the pulicine life cycle. Hitherto the embryological phase of this cycle has been neglected in spite of the fact that its other aspects have received considerable attention. A careful search of the literature reveals only five contributions to the subject of flea embryology, and they are all brief and fragmentary. In some cases the claims made therein have been found to be erroneous in the light of the present study. These discrepancies are doubtless due to the difficulties involved in the technique of preparing the eggs for successful observation.

Weismann (1863) was the first to undertake an investigation of the development of the flea in the egg stage, but he dismisses the subject with a single page of his lengthy paper which is otherwise concerned with the embryology of *Chironomus* and *Musca*. He chose the dog flea, *Ctenocephalides canis* (Curtis), as the species for his consideration and reports that in the egg of this form "although the chorion is not exactly opaque it does not allow observation of the finer details, which, to be ascertained accurately, require a well related series of observations. Yet it mocks at every attempt to remove it without injury to the yolk membrane." Weismann concludes, therefore, that the egg of the flea is not favorable for embryological study.

The second worker to publish on the subject of flea embryology was Packard (1872). He used the eggs of the cat flea, *Ctenocephalides felis* (Bouché), although, believing like other workers of his day that cat and dog fleas constituted a single species, he titled his discussion "The Development of *Pulex canis*." Like Weismann, he was forced to restrict his studies to superficial observations inasmuch as the section method of investigation was not well developed.

Balbani (1875) was the third to attempt to work out the early ontogenetic development of fleas. He followed Packard in the use

of cat flea eggs and observed that in them the chorion is more transparent than in the ova of other siphonapteran species. He recognized the inadequacy of the study of whole eggs, for he says in this paper, "The delicate question of embryology can only be studied with profit by the sectioning method, but the egg of the flea is too small to bear this mode of investigation." Balbiani can scarcely be blamed for reaching this conclusion when the small size of cat flea eggs is considered together with the fact that at that time no insect eggs had been sectioned with any degree of success. Considering the absence of efficient microtomes and biological stains, necessitating the limited methods of research employed by Balbiani and his two predecessors in the investigation of flea embryology, the results which these pioneers obtained must be admired. Although obviously superficial, as well as inaccurate in some instances, the papers of these first students of flea development are, nevertheless, definitely superior to those of the two writers on this subject who followed them and who had many of the technical advantages of modern equipment.

The first one to utilize the section method in studying flea eggs was Tikhomirowa (1890). This paper is not available to the writer, but a review of the main points given therein is presented by its author in another of her papers (1892) which deals with the development of *Chrysopa*. For the most part her conclusions regarding flea development are inaccurate.

Strindberg (1917) was the second to apply the section method to the investigation of pulicine embryology. His brief paper is concerned only with the intermediate developmental phases of *Archopsylla erinacci* (Bouché). Concerning the other periods he says: "The early embryonic stages scarcely present worthwhile observations." "The later embryonic stages do not show anything worthy of note and therefore are not taken into account." A critical examination of this author's statements necessitates the conclusion that his material was very inadequate.

The second respect in which the study of flea embryology is of particular interest is that which is concerned with its application to the phylogenetic position of the Siphonaptera. A study of the literature suggests that there has been more speculation on the subject of the affinities of the fleas than of any other insect order. This interest in the natural relationships of fleas seems to have been the chief stimulus which has prompted previous investigators to undertake studies of their development, for their papers include discussions of the racial origin of these insects. While accurate comparative embryological observations are invaluable in the solution of phylogenetic problems,

it must be recognized that much of the past work in the field of insect embryology is inaccurate. This is evidenced by the distinctly opposite interpretations which frequently have been given by workers on the same species. In view of this fact it is inadvisable for the writer to attempt a phylogenetic application of the present observations until he has personally investigated the embryology of those forms which are suspected of being most closely related to the Siphonaptera. Only then can it be certain that the same methods and interpretations have been applied to the different subjects and that the comparisons are worthwhile.

### SPECIES

The observations made during this study indicate that the embryological development of all fleas is essentially the same. Except for such superficial characteristics as size, nature of the chorion, and the number of micropyles, the corresponding stages of the eggs of different species appear to be identical. This was shown by making careful studies on the development of three species of diverse systematic positions. These included *Ctenocephalides felis* (Bouché), the cat flea; *Nosopsyllus fasciatus* (Bosc.), the common rat flea of temperate regions; and *Hystrichopsylla dippiei* Roths., a giant form which lives in the nests of the wood rat *Neotoma*.

Following the classification of Oudemans (1909), the order Siphonaptera is divided into two suborders on the basis of the presence or absence of a dorsal suture on the head. Fleas which possess such an incrustation are placed in the suborder Fracticipita, while those which lack it constitute the suborder Integricipita. If this division is a natural one based on true relationships, the choice of the three species used in this study is valid. *Ctenocephalides felis* and *Nosopsyllus fasciatus* belong to the Integricipita, while *Hystrichopsylla dippiei* is classed in the Fracticipita.

In contrast to Oudemans' system, many authors, including Ewing (1929), consider that the subdivision of the Siphonaptera into these two groups is artificial and unwarranted owing to the number of intermediate forms in which it is difficult to determine whether or not a dorsal suture is present, and also because of the lack of sufficient correlating characters. These authors prefer to follow the classification of Baker (1905) which regards the Siphonaptera as a compact group and, accordingly, divides it directly into families. Based on this classification, the choice of species for this study is again found to be a satisfactory one inasmuch as the three forms selected belong to three different families. *Ctenocephalides felis* represents the Puli-

cidae, *Nosopsyllus fasciatus* the Dolichopsyllidae, and *Hystrichopsylla dippicii* the Hystrichopsyllidae. Moreover, these three families together contain over 80 percent of the total number of genera belonging to the order. The three subject species used in this study must be regarded, therefore, as a valid representation for the Siphonaptera as a whole.

#### EGG SOURCES

*Ctenocephalides felis* proved to be the most prolific of the three species studied. The eggs of this flea were collected from a cat's sleeping blanket by means of a camel's hair brush.

*Nosopsyllus fasciatus* eggs were obtained from a pure culture of this species reared on white mice by the methods described by Leeson (1932). Gravid females were confined in voile-capped vials until they had oviposited. It was found that these imprisoned insects lived longer and deposited more eggs if a piece of cotton was placed in the vial with them.

The eggs of *Hystrichopsylla dippicii* were obtained either from the nests of wood rats or from gravid females taken from such nests. Because the eggs of this species are so much larger than those of the several other forms which inhabit *Nicotoma* nests, there was no danger of mistaken identity.

#### AGE DETERMINATION

In order to determine the developmental age of embryos in terms of days, cat flea eggs, newly laid by females imprisoned in vials, were incubated under a constant temperature of 25° C. and a relative humidity of 79 percent. Relatively few eggs were incubated in this manner; these were used as standards and the others studied were interpolated into the series in their proper places. As no attempt was made to obtain *Nosopsyllus fasciatus* and *Hystrichopsylla dippicii* eggs of accurately determined incubation age, the developmental stages of these species were compared to known ones of *Ctenocephalides felis*.

#### MICROTECHNIQUE

In the preparation of whole mounts of *Ctenocephalides felis* embryos, dechoriation was facilitated by heating the eggs at 90° C. for a few minutes. The heat served to coagulate the yolk so that it drew away from the chorion, thereby providing a working space between the shell and the vitelline membrane. The resulting solidification of the vitellus was a further advantage because a yolk so hardened



does not rupture easily. The relatively thin chorion of the cat flea egg was an added factor in making dechoriation in this species a simple matter. This membrane collapses as soon as it is punctured and is thereafter quite easily removed under the binocular by dissecting it away with a fine pointed needle.

Because the eggs of *Nosopsyllus fasciatus* and *Hystrichopsylla dippiei* have thicker shells and therefore do not ordinarily collapse when punctured, a different procedure was necessary for the removal of their chorions. After heating, the surfaces of these eggs were dried thoroughly with blotting paper and they were immersed in liquid paraffin on a glass slide. When the paraffin had hardened, a series of needle punctures was made completely around the egg through both the paraffin and the chorion. Next, the adjacent punctures in the paraffin were connected and the paraffin cap, thus formed, was removed. Finally, the punctures through the exposed chorion were connected and the upper surface of this shell was removed in one piece. The shrunken vitellus with its attached embryo was lifted through the resulting opening by means of a minute spatula. Dechorionated eggs were fixed in Bouin's picro-formol-acetic fluid, stained with alcoholic borax-carmin, destained in 70 percent acid ethyl alcohol, cleared in cedar oil, and mounted in xylol-balsam.

Eggs used for sectioning were neither heated nor dechorionated. However, owing to the impermeability of the chorion, this membrane was punctured before fixation. Puncturing was done in the same Bouin's fluid which was to serve as the fixing reagent. Several punctures were made in each egg. Tertiary butyl alcohol, as recommended by Johansen (1935), was used for washing and dehydration. Imbedding was accomplished by a combination technique involving modifications of two previously used methods. These were Boycott's well-known paraffin-celloidin technique and Walls' (1932) adaptation of the hot-celloidin process to animal tissues. From absolute tertiary butyl alcohol, the eggs were placed in a 2 percent solution of celloidin dissolved in ether-alcohol. Infiltration was done in small glass tubes, 3 mm. in diameter. These were cut into short lengths and closed at one end. Such infiltration bottles, containing the eggs in 2 percent celloidin, were placed, uncorked, in a metal cylinder capable of withstanding high pressure. After being sealed, this cylinder was placed in an electric oven with the temperature set at 60° C. where the heat, acting on the ether-alcohol solvent, provided the necessary pressure to force the celloidin into the tissue. After 24 hours the cylinder was removed from the oven, cooled, and opened. At this point the step from Boycott's method was incorporated into the procedure. About

half of the 2 percent ether-alcohol celloidin was removed from each tube, and an equal amount of 3 percent celloidin dissolved in clove oil was added, after which the infiltration under heat in the pressure cylinder was continued for another 24 hours. Following this second period, the celloidin was gradually thickened by suspending a tiny piece of parlodion in the upper part of the solution, after which the pressure infiltration was carried on for another day. Such additions of parlodion were made daily until the solution reached the proper consistency for imbedding.

Hardening of the celloidin blocks was accomplished by immersing the open infiltration tubes in chloroform for several days. It was important, however, that the contents of the tubes be thoroughly cooled before the hardening was begun. After hardening was completed, each tube was tapped with some hard object until its glass wall was cracked in several places. The resulting pieces of glass were carefully picked away from the celloidin, and the block was soaked in chloroform until it ceased to float.

The completely hardened celloidin block was infiltrated in paraffin preparatory to double imbedding. During this process the clove oil in the celloidin matrix was partially replaced by paraffin, thereby eliminating the possibility of the celloidin pulling out from its paraffin coating during sectioning.

Because of the tendency of the celloidin matrix to warp during heating and drying, the following method for mounting the ribbons was used. The surface of the slide was first swabbed with a thick layer of albumen fixative. Good quality cigarette papers were cut in half longitudinally, and each half was laid on a flat surface and saturated with distilled water. The microtomed ribbon was cut into strips of the desired length, and these were laid in reverse order on the paper. More distilled water was then applied to the paper, and the resulting surface tension aided in pulling the ribbons out until they were fairly flat. Thereafter, the paper was lifted up with the sections adhering to it, reversed, and laid ribbon-side down on the albumen-smearred slide. The whole was immediately blotted with several thicknesses of filter paper, a finger being rolled over this paper from one end of the slide to the other, thereby insuring direct contact between the sections and the slide at all points. Sections mounted in this manner were certain to be flat and therefore suitable for photographic purposes.

Again, because of the tendency of the celloidin to warp, no period of drying was allowed following mounting. Instead, as soon as the cigarette paper was pulled away, leaving the ribbon adhering to the

slide, all traces of water were quickly wiped from the under surface of the glass, and the slide was passed directly into xylol. Absolute tertiary butyl alcohol was used following the removal of the paraffin by xylol because it was desired to keep the celloidin matrix intact, and this alcohol does not dissolve celloidin.

In order to make certain that the sections would remain firmly attached to the slide during the staining process, a step was adapted from Galigher (1934) and introduced into the procedure at this point. This consisted of dipping the slide into a 1 percent solution of ether-alcohol celloidin and then passing it into chloroform to harden the film. Thereafter, the slide was transferred to 95 percent tertiary butyl alcohol for the beginning of hydration preparatory to aqueous staining. The lower alcohols used in the series were either tertiary butyl or ethyl solutions, inasmuch as the latter possessed sufficient water to prevent the dissolution of the celloidin matrix and protective film. It was necessary that dehydration following staining be completed with tertiary butyl alcohols.

Sections were stained by various methods, the combination of Delafield's haematoxylin with Eosin Y as a counterstain being used for most of them. Mayer's haemalum with a counterstain of Fast Green FCF, and Heidenhain's iron haematoxylin with a counterstain of Eosin Y were also used to some extent. Heidenhain's iron haematoxylin was found unsatisfactory for the earlier stages because it colored the numerous yolk spheres so darkly that they dominated the entire picture and obscured both the cleavage nuclei and the tropho-nuclei (pl. 1, fig. 13).

Because the eggs used in this study were obtainable in such large numbers, it was possible to infiltrate and imbed them en masse, several hundred to a block. No attempt was made at orientation, and those sections which were cut at undesirable planes were ignored (pl. 4, figs. 39, 40).

#### CHARACTERISTICS OF THE EGGS

The eggs of fleas are regularly prolate-spheroidal in shape. Consequently, they do not possess any dorsoventral differentiation such as is exhibited by the ova of many other insects. When first deposited, the eggs of all three species of fleas considered in this paper are glistening white. There is a pronounced difference in the degree of their transparency, however. Those of *Ctenocephalides felis* are relatively transparent, those of *Hystrichopsylla dipptici* less so; those of *Nosopsyllus fasciatus* are the most opaque. While the eggs of all fleas

tend to become more opaque as they age, those of the cat flea are by far the most transparent at every stage of development. Color differences also become manifest as development progresses. The eggs of the cat flea remain relatively colorless, those of the other two species assume a cream color within a few hours after being laid. This coloration is retained by the eggs of *Hystrichopsylla dippici*, but in the case of *Nosopsyllus fasciatus* the eggs often acquire a darker hue which sometimes approaches a reddish brown before hatching. These variations in color and transparency are due primarily to chorionic differences between the species, correlated with differences in egg size. A relatively thick chorion, combined with small egg size, makes an egg more opaque and darker in color.

Of the three species here considered, the eggs of *Hystrichopsylla dippici* are much the largest, approximately 1.9 mm. in length and 0.9 mm. in greatest diameter. Corresponding measurements for the two other species were 0.8 mm. and 0.4 mm. for *Nosopsyllus fasciatus*, and 0.5 mm. and 0.3 mm. for *Ctenocephalides felis*.

The outer surfaces of most insect eggs are sculptured with a reticulum of slightly raised ridges which enclose polygonal spaces. These markings represent the imprints of the ovarian follicle cells which serve to secrete the chorion. In the eggs of *Nosopsyllus fasciatus* and *Hystrichopsylla dippici* this sculpturing of the chorion is rather pronounced. However, in the cat flea egg it is scarcely perceptible, even when the egg surface is thoroughly dried after oviposition. The chorionic markings of this species are so indistinct that Balbiani (1875) characterizes the chorion of the cat flea egg as unsculptured. He says, "The rugose appearance, like scales, that the egg presents on its surface, is not inherent in this membrane as Leuchart thought, but is due to the coating that the egg receives at the moment of deposition." Balbiani does not state what procedure he followed in reaching this conclusion, but it may be assumed that he failed to see markings on the chorionic surfaces of eggs dissected directly from the ovarioles. A failure of this type is attributable to the fact that as long as the chorion is wet its sculpturing is difficult to make out. This is true even in the case of *Nosopsyllus fasciatus* or *Hystrichopsylla dippiei* eggs in which the reticulations of the chorion are very evident when this membrane is dry. As cat flea eggs tend to collapse in a short time after they are dissected from the ovariole, it is probable that Balbiani examined the eggs before they had dried sufficiently to show the chorionic sculpturings clearly. The faint reticulations which may be seen on the chorion of the *Ctenocephalides felis* egg are without doubt

homologous to the sculpturings on the egg surfaces of other insects, representing the imprints of the cells of the follicular epithelium.

In section the chorion of the cat flea egg appears as an extremely thin single membrane (pl. 4, figs. 39 to 42). By contrast, the chorions of *Nosopsyllus fasciatus* and *Hystrichopsylla dippiei* are considerably thicker. In the latter of these species this membrane appears as a rigid shell made up of two laminae which are united by countless, extremely slender, transversely arranged, supporting pillars (pl. 1, fig. 2). These two chorionic layers appear to correspond to the exochorion and endochorion which Blochmann (1887b) and Wheeler (1889) have described for certain other insects.

In all of the three flea species studied, a second protective covering lies beneath the chorion. This is the yolk or vitelline membrane (pl. 6, fig. 53; pl. 11, fig. 79). It is thin in all species and, like the chorion, is noncellular. Its relative position in regard to the chorion and the yolk surface varies in different preparations, but as a rule it lies nearer to the latter in the younger stages. The vitelline membrane appears to be merely the attenuated limiting membrane of the developing oocyte which has been secreted by the superficial protoplasm. It remains intact until the time of eclosion.

Spermatozoa traverse the chorion and the vitelline membrane of insect eggs by means of micropylar openings. In flea ova these are arranged in two circular areas, one at each pole (pl. 1, fig. 1). These micropylar apparatuses have been observed previously in the eggs of *Ctenocephalides felis* by Balbiani (1875). The number of openings at the respective poles in the eggs of any one species is variable, but is always considerably greater at the anterior pole in any individual egg. Furthermore, the minimum for the anterior pole number is always somewhat greater than the maximum for the posterior pole number in the same species. Balbiani found that in the case of cat flea eggs the number of anterior micropylar openings varied from 45 to 50, whereas his counts gave only 25 to 30 such pores for the posterior pole. However, the writer's counts show a greater variation in the case of each pole. The micropylar openings at the anterior pole were found to number as few as 35 or as many as 55, whereas the posterior apparatus was found to consist of from 20 to 30 such openings.

It appears that the micropylar apparatuses in the eggs of *Nosopsyllus fasciatus* and *Hystrichopsylla dippiei* have not been described previously. In the former the number of openings at the respective poles corresponds closely to the range given above for *Ctenocephalides felis*. In *Hystrichopsylla dippiei* the pores are fewer in number at both

poles; the anterior apparatus in this species was found to possess 30 to 40 such openings, whereas the posterior one gave counts of from 15 to 25. In all three species studied, the openings at each pole were found to tend toward a spiral arrangement.

In *Hystrichopsylla dipfici* there may be a number of volcanolike raised processes arranged irregularly around the margin of the micropylar area (pl. 1, fig. 2). Their general appearance suggests the so-called micropyles of *Phyrrhocoris apterus* illustrated by Packard (1898, fig. 501), but longitudinal sections through them have failed to demonstrate for certain that the minute canals which pass inward from their craters perforate the chorion. Therefore, their function as supplementary micropyles is doubtful. The eggs of *Nosopsyllus fasciatus* and *Ctenocephalides felis* appear to lack these peculiar structures.

Balbiani (1875) was of the opinion that in cat flea eggs only the anterior group of micropylar openings served as passageways for the entrance of spermatozoa, since he found what he interpreted as spermatic filaments caught only in the anterior openings. None of the preparations made during the present study show any structures lodged in the openings of either pole which may be interpreted with any degree of certainty as spermatic tail pieces. Furthermore, longitudinal sections of the eggs of all three species demonstrate clearly that the lumina of the pores of both the anterior and the posterior micropylar apparatuses pass through the chorion. It is probable, therefore, that in the case of flea eggs the openings of both the anterior and posterior micropylar areas serve as passageways for the entrance of spermatozoa.

The difference in the number of micropylar pores present at the poles is the only external indication of anterior-posterior differentiation in flea eggs. The identification of the poles was made by opening eggs in which the embryos had developed sufficiently to permit positive recognition of the cephalic and caudal ends. This identification made it possible to test the Law of Hallez (1886) as applied to flea eggs. Eggs for this purpose were dissected from the oviduct, and invariably their anterior poles were directed toward the head of the mother. Because flea eggs possess no dorsoventral differentiation until development is well advanced, no attempt was made to test the Law of Hallez in respect to this second axis.

Some authors, such as Huettner (1923), describe a third protective membrane for insect eggs. This they term the plasma membrane. It is described as an extremely thin investment adhering closely to the

superficial protoplasm and difficult, therefore, to demonstrate. Such a covering, if present, would lie inside of the vitelline membrane and would be evident when the germ cells push out at the posterior pole as described in a later section. Such a membrane is not apparent in flea eggs.

The superficial protoplasm of insect eggs is known as the periplasm or cortical ooplasm. The periplasm at the anterior pole is called the anterior polar plasm, and that at the posterior pole is termed the posterior polar plasm. In the eggs of many forms either one or both of the polar plasm regions are widened to form protoplasmic caps which some authors regard as adaptations to facilitate the entrance of spermatozoa. As will be described later in the section on germ cells, most writers on insect embryology believe that the posterior polar plasm plays an important role in the differentiation of the primordial germ cells. In comparison with the eggs of most other insects, those of fleas possess a very narrow periplasm, and none of the sections made during this investigation showed it widened to form an anterior protoplasmic cap. However, some of the sections have this cortical ooplasm perceptibly thickened at the posterior pole (pl. 5, fig. 43). The entire periplasm is uniformly granular and no darker-staining granules are in evidence in this posterior protoplasmic cap.

The periplasm is continuous with an anastomosing reticulum of protoplasmic strands which ramifies throughout the inner portion of the egg. Contained within the meshes of this reticulum are numerous vitelline spheres which make up the deutoplasm or store of yolk for the nourishment of the developing embryo. These vitelline spheres vary considerably in size. Lying within each of them are several small, rounded, and refringent bodies. These are the vitelline bodies. Both vitelline spheres and their vitelline bodies appear in many of the accompanying photomicrographs (pl. 1, figs. 4, 5, 8, etc.). Delafield's haematoxylin was found to leave both the vitelline spheres and vitelline bodies colorless, and was used for the sections from which the above illustrations were made. By contrast, Heidenhain's iron haematoxylin stains both structures black (pl. 1, fig. 13).

Multitudes of granulelike objects, apparently identical with the granules of the periplasm, may be present along the strands of the protoplasmic reticulum (pl. 5, fig. 45). These are by no means uniformly distributed, and their concentration varies in different preparations. They appear to correspond to the Blochmann's corpuscles which have been observed in the eggs of certain other insects. These bodies were first observed by Weismann (1863), and, although he includes a short discussion of the development of the dog flea egg in this

same paper, he fails to mention the presence of such bodies in this species. Blochmann (1884, 1886, 1887a) studied these small corpuscles in the eggs of a number of insects and concluded that they play an important part in embryonic development. Because he observed their multiplication by transverse fission, he concluded them to be bacterial organisms. Mercier (1906) substantiated Blochmann's supposition by successfully culturing them in artificial media. Owing to the great variability of the number of these bodies in flea eggs, it seems improbable that they are of importance in the embryonic development of these insects. No attempt was made to culture these structures.

#### MATURATION

In unfertilized flea eggs, the position of the female pronucleus is somewhat variable, being dependent upon the maturation processes. Some of the preparations of newly deposited eggs show that they contain only two nuclei and that these are lying close together in the margin of the anterior polar plasm. Such a preparation apparently represents a stage immediately following the first maturation division, one of the two nuclei representing the first polar body and the other the secondary oocyte. Sections from other newly laid eggs show that the second maturation division has already taken place, as two polar body nuclei may be seen lying in the periplasm, while a third or ootid nucleus lies toward the interior of the egg. The polar body nuclei of fleas, like those of other insect forms, are never extruded from the egg but remain within the anterior periplasm until they disintegrate. The first polar body appears to remain undivided. Following the second maturation division the ootid nucleus migrates toward the center of the egg. Oviogenesis, or the differentiation of the ootid nucleus into the female gametic nucleus, takes place during this migration. This maturing process prepares the female nucleus for syngamy with the male gametic nucleus.

#### SYNGAMY

Figure 12 (pl. 1) shows a longitudinal section through the anterior half of a cat flea egg in a stage just prior to syngamy. Only four nuclei are evident in the entire egg and three of them are present in this section. These are the female gametic nucleus, the male gametic nucleus, and one of the polar body nuclei. The second polar body lies at a different level and appears in another section. The large number of micropylar openings occurring in flea eggs is suggestive of



polyspermy, but if other spermatozoa have entered this particular egg they have apparently disintegrated. The actual process of fertilization, or the fusion of the male and female gametic nuclei, is shown in figure 37 (pl. 4). It occurs in the central region of the egg, as a rule somewhat toward the anterior pole. The zygotic nucleus resulting from syngamy is shown in figure 38, and the complete section from which this enlargement was made is shown in figure 39.

#### CLEAVAGE

As is typical for the eggs of insects, cleavage in fleas is meroblastic peripheral, owing to the centrolecithal nature of the ovum. By a series of synchronous mitotic divisions, several generations of so-called cleavage cells are produced by the zygotic nucleus. As Blochmann (1887b) first pointed out, these bodies are not independent cells, inasmuch as each is connected by protoplasmic strands to the protoplasmic reticulum which ramifies throughout the vitellus, and by this reticulum, in turn, to the periplasm. In flea eggs, each cleavage nucleus is surrounded by a star-shaped protoplasmic mass, and this is continuous with the protoplasmic reticulum. Such cleavage nuclei, therefore, have the same general appearance as the zygotic nucleus. Like it, they stain rather faintly.

Synchronous cleavage divisions have been reported for a number of insect species. Huettner (1923) found them to occur in *Drosophila*, Auten (1934) in *Phormia*, and Butt (1936) in *Brachyrhinus*. Their presence in flea development, however, has not been observed heretofore.

During the early cleavage divisions the resulting nuclei lie rather close together in the central region of the egg. Not until after the completion of the fifth such division, when the egg is in the 32 nucleus stage, is there an indication of any orderly migration of the cleavage nuclei toward the periphery. Following the next or sixth cleavage division, when 64 segmentation nuclei are present in the egg, the majority of these have definitely begun their migration to the surface. In doing this they collectively assume a hollow spheroidal arrangement which is proportionate in all its dimensions to the outline of the egg. The nuclei which outline this spheroid are all approximately equidistant from the cortical ooplasm which forms the surface of the egg mass. Huettner (1923) says that in *Drosophila* the cleavage nuclei start their migration to the surface after the eighth cleavage division, or when the egg is in the 256 nucleus stage. In flea eggs, therefore, this migration starts somewhat earlier.

It has been stated above that the majority of the cleavage nuclei migrate to the surface of the egg. The relatively few that remain behind in the vitellus are destined to produce the primary trophonuclei.

The migrating cleavage nuclei continue to rise toward the surface of the egg but undergo another cleavage division, the seventh, before they reach the periplasm. In flea eggs it is at the 128 nucleus stage, therefore, that the cortical layer is first supplied with nuclei. Mention should be made of the fact that the mitotic spindles of this seventh division are parallel to the egg's surface and, as a consequence, the daughter nuclei retain the spheroidal arrangement already described for their parent nuclei. Wheeler (1889) for *Blatta*, Heymons (1895) for *Forficula*, and Lécaillon (1897) for *Clytra*, have described a similar orientation for the mitotic spindles of the cleavage division just prior to the arrival of the nuclei in the periplasm.

There is a great deal of variation among insect eggs as to the exact region of the periplasm at which the cleavage nuclei first reach the surface. In *Pieris* (Bobretzky, 1878) and *Chironomus* (Weismann, 1882) the first nuclei arrive in the cortical protoplasm at the anterior pole. In *Formica* (Ganin, 1869) and *Musca* (Graber, 1889) the surface of the egg is attained first at the posterior pole. Auten (1934) says that in *Phormia* the nuclei arrive at the two poles slightly before they reach the other surfaces of the egg. In *Hydrophilus* (Heider, 1889), *Platygaster* (Kulagin, 1897), and *Calendra* (Wray, 1937) the surface of the egg first reached is between the poles in the equatorial region. In certain other insects such as *Blatta* (Wheeler, 1889) and *Apis* (Nelson, 1915) the ventral surface somewhat anterior to the equator is the region first reached. In *Callopteryx* (Brandt, 1869) the nuclei are said to arrive at the surface in groups. In the development of flea eggs the arrival of the nuclei at the surface does not correspond to any of the above cases for, as a rule, in pulcid ova the nuclei arrive at the periplasm simultaneously at all points. This is not surprising in view of the regular symmetry of these eggs and the fact that the nuclei approach the surface arranged in the form of a hollow, single-layered figure, the outline of which conforms very closely to the shape of the egg surface. The only exception to the simultaneous arrival of the nuclei at the surface is that in some eggs the most posterior nuclei arrive at the periphery a little later than the others. This is apparently due to the fact that the zygotic nucleus sometimes begins dividing at a point slightly anterior to the middle of the egg. As these most posterior cells tend to become germ cells, their further history is postponed for later consideration.

The number of cleavage nuclei arriving in the cortical ooplasm of flea eggs is inadequate to constitute at once a continuous epithelium such as is characteristic of the blastula stage. As stated above, it is at the 128 nucleus stage or after the seventh cleavage division that the periplasm is first supplied with nuclei. The 15 or so nuclei which are to be seen at the periphery in a median longitudinal section at this stage are rather regularly distributed but widely separated from each other (pl. 1, fig. 4). This condition contrasts with the situation which occurs in *Calliphora* (Blochmann, 1887b) and *Hydrophilus* (Heider, 1889), in which the nuclei reach the periplasm closely crowded together. In the embryological development of fleas, therefore, there must be a further multiplication of the nuclei in the periplasm before the stage comparable to that in which the nuclei arrive at the periphery in *Calliphora* and *Hydrophilus* is reached. For the sake of convenience, although there is as yet no cessation of nuclear division at any surface region, cleavage may arbitrarily be said to terminate with the arrival of the cleavage nuclei at the egg's surface. The embryonic differentiations which immediately follow this stage and which lead up to the completion of the blastoderm collectively constitute what is herein termed blastulation.

#### BLASTULATION

At the conclusion of cleavage the egg may be said to be in the blastema stage. This term was first used by Weismann (1863) to designate the nucleated periplasm in the eggs of dipterans before its division into cell territories. Although he was mistaken in assuming that the nuclei in this layer have a spontaneous origin, later workers, such as Patten (1884) and Wheeler (1889), have used the term without objection. When the general definition of blastema, viz, the primitive basis of a structure yet undifferentiated and from which such a structure grows, is considered, it must be admitted that the nucleated periplasm of insect eggs comes within the meaning of the term when its function as the primitive basis for the blastoderm is taken into account. For this reason, the precedent established by Patten and Wheeler is herein followed.

Four substages of the blastema are to be recognized in the eggs of fleas, each determined by the number of nuclei which are present in the periplasm. The first of these has already been described as being synonymous with the 128 nucleus stage. The second, third, and fourth blastema substages correspond to the 256, the 512, and the 1024

nucleus stages respectively. The details of the differentiations of these various stages deserve special consideration.

Mention has been made of the fact that at the last or seventh cleavage division, which occurs during the migration of the pre-blastema nuclei to the periplasm, the mitotic spindles are arranged parallel to the egg's surface, thus insuring that the daughter nuclei will be equally distant from the periplasm when they are formed. All the division planes of the three subsequent nuclear divisions likewise are at right angles to the egg's surface. This phenomenon serves to retain the single-layered arrangement of the nuclei in all the blastema substages.

Immediately following the eighth nuclear division or when the egg is in the 256 nucleus substage of the blastema, the two daughter nuclei of any one parental nucleus lie close together. Soon, however, they draw away from each other until they are approximately equidistant from the adjacent nuclei and from each other (pl. 1, fig. 5; pl. 4, fig. 40). The egg is then ready for the ninth nuclear division. This, and the tenth division, take place in the same manner as the eighth, although the pairs of daughter nuclei are less apparent owing to the greater number and resultant crowding of the nuclei in the periplasm. The third blastema substage, following the ninth nuclear division, is shown in figures 3, 10, and 11 (pl. 1) and in figures 41 and 42 (pl. 4). Figures 8 (pl. 1) and 49 (pl. 6) represent the fourth blastema substage. This follows the tenth nuclear division and corresponds to the 1024 nucleus stage.

In the fourth blastema substage, all of the first true blastodermic nuclei are accounted for. All that remains to transform the blastema into the blastoderm is the separation of the individual nuclei with their adjacent cytoplasm into distinct cell territories. The cells delineated in this manner are the first true cells of the developing egg. Some 120 of them are present in a median longitudinal section of the primary blastodermic stage or the first substage of the blastula (pl. 1, figs. 7, 9; pl. 5, fig. 48). The discussion of the second and third blastula substages is postponed to the section on the formation of the germ band.

The cytoplasm of the blastoderm has two sources. Part of it is derived from the thin periplasmic layer, and the remainder has been carried into this region by the immigrating cleavage nuclei. The first indication of the delimitation of the cell territories of the blastoderm is the appearance of slightly rounded swellings at the surface of the egg. These swellings are opposite the individual peripheral nuclei. Almost immediately the lateral cell walls begin to form. They begin at the surface and gradually extend inward. The nuclei do not lie in

the absolute centers of their forming, respective cell territories. Instead, each is located somewhat toward the outer margin. With the completion of the lateral cell walls, the cell territories still remain incompletely demarcated, as the cytoplasm of their bases is still connected. It is also continuous with the reticular protoplasm of the interior of the egg. Although these phases of blastulation are typical for centrolecithal insect eggs, the final step, consisting of the development of the inner walls of the blastoderm cells, varies as to details in different forms. In the eggs of certain insects such as *Hydrophilus* (Heider, 1889) and *Apis* (Nelson, 1915) an inner peripheral or cortical protoplasmic layer is produced. It is believed to be composed entirely of protoplasm which has come to the surface with the cleavage nuclei. This zone has only a temporary existence owing to the fact that it is ultimately absorbed by the blastoderm cells. A true layer of inner peripheral protoplasm was not found by Marshall and Dernehl (1905) in their study of *Polistes*, although a small amount of cytoplasmic substance was observed just inside the bases of some of the completed blastodermic cells. An inner layer of peripheral protoplasm is said by Carrière and Bürger (1897) to be entirely lacking in *Chalicodoma* and *Anthophora*. As the eggs of these last two genera have a relatively thin periplasmic layer, and as this is also the case in flea eggs, an inner peripheral protoplasmic layer was expected to be lacking also in the developing ova of these insects. A deficiency of cytoplasmic material in the cortical layer would be expected to necessitate the incorporation at once into the blastodermic cells of all the protoplasm which had come to the surface with the cleavage nuclei. However, careful examination of sections of flea eggs representing this stage indicates an agreement with the eggs of *Polistes* rather than with those of *Chalicodoma* and *Anthophora*. Although thin, irregular, and ill-defined, cytoplasmic patches may be seen lying just below the bases of certain of the blastoderm cells. This may be regarded as homologous to the definite inner layer of peripheral protoplasm of certain other insects.

#### TROPHONUCLEI

As already stated, after the sixth cleavage division when 64 segmentation nuclei are present in the egg, a variable number of these start migrating toward the surface as the preblastema nuclei. Within the spheroidal figure which they outline are the remaining nuclei which, with their progeny, stay in the central portion of the egg. Here they probably serve to liquefy the yolk which surrounds them, making

it available as nourishment for the cells of the developing embryo. Because of this function, they may be termed trophonuclei or vitellophags. It would be incorrect to call them trophocytes because, like the cleavage nuclei, the cytoplasm surrounding them is not marked off into cell territories. In order to emphasize this point, the term trophonucleus is used hereafter. During the preliminary cleavage divisions all of the trophonuclei divide simultaneously with the other nuclei. Later, however, the division of the trophonuclei is irregular. This is demonstrated by the fact that while these nuclei disperse soon after division, some preparations show a few lying close together in pairs. This irregular division of the trophonuclei has been described previously for *Apis* by Nelson (1915).

In some insects, such as *Leptinotarsa* (Wheeler, 1889) and *Clytra* (Lécaillon, 1898), a phenomenon known as secondary yolk cleavage is said to occur. In these forms the yolk is divided into polyhedral masses, each of which contains a trophonucleus. This segmentation serves to divide the protoplasmic reticulum of the vitellus as well, so that in these forms each yolk segment with its trophonucleus and surrounding cytoplasm may properly be regarded as a yolk cell. Only in such cases is the term yolk cell applicable. In agreement with the majority of other insects, such segmentation of the vitellus is not shown in any of the numerous sections of flea eggs made during this study. Therefore, for the vitellophags of the eggs of Siphonaptera the term trophonucleus rather than yolk cell is correct.

The origin of the primary trophonuclei from cleavage nuclei which have remained behind in the yolk has been demonstrated in numerous insects by various authors including Bobretzky (1878) for *Pieris*, Kowalevsky (1886) for *Calliphora*, Wheeler (1889) for *Leptinotarsa*, and Nelson (1915) for *Apis*. On the other hand Patten (1884) for *Neophylax*, Will (1888) for *Aphis*, Wheeler (1889) for *Blatta*, and recently Du Bois (1932) for *Sciara*, state that all the cleavage nuclei migrate to the surface so that none of them are left to produce the primary vitellophags. In the eggs of fleas a few nuclei, as in the majority of insect forms studied, remain behind in the vitellus and these in turn give rise to the primary trophonuclei. Tikhomirowa (1892) has already made this observation for the composite species *Pulex serraticiceps*. Strindberg (1917), in his study of the development of *Archacopsylla crinacci*, failed to find yolk nuclei at any stage.

Not all trophonuclei are of this primary type, however. They must of necessity have some other source in those forms in which all of the nuclei pass to the periplasmic layer. Patten (1884) says that in *Neophylax* the yolk nuclei arise at a later stage by the immigration of

nuclei into the vitellus from both the serosa and the ventral plate. Graber (1871) had previously shown that in forms possessing primary trophonuclei, these are augmented by additional or secondary vitellophags which enter the yolk from the germ band. Numerous other workers, including Korotneff (1885) for *Gryllotalpa*, Noack (1901) for *Calliphora*, Nelson (1915) for *Apis*, Butt (1936) for *Brachyrhinus*, and Lassmann (1936) for *Melophagus*, have substantiated his observations. In flea eggs, such an augmentation of the primary vitellophags by others of a secondary nature occurs, notwithstanding the statement of Tikhomirowa (1892) to the contrary. This augmentation is by immigration from the surface. These secondary trophonuclei may enter the yolk either from the blastoderm or from the mesoderm when this germ layer has differentiated. None of them appear to come from the serosa as Patten (1884) described for *Neophylax*. In spite of their origin from the completely delimited cells of the blastoderm or mesoderm, the secondary vitellophags appear to lose their cellular nature as they enter the yolk. Their cell boundaries break down and they become incorporated into the cytoplasmic syncytium which ramifies through the vitellus. Having lost their demarcations, these vitellophags can no longer be regarded as independent cells. Instead, they must be termed trophonuclei like the primary vitellophags. Such secondary trophonuclei appear indistinguishable from those of the primary group once they have passed deeply into the yolk. When first given off by the blastoderm, they stain rather deeply and correspond in the density of their coloration to the cells of the superficial layers. The subsequent decrease in the staining ability of the secondary trophonuclei appears to be due to the dispersion or dissolution of their substance. A similar phenomenon has been observed by Heymons (1895) in *Gryllotalpa*, *Gryllus*, and *Forficula*, by Friederichs (1906) in *Meloë*, and more recently by Eastham (1927) in *Pieris*.

#### ORIGIN OF THE GERM CELLS

The origin of the primordial germ cells in insects was first observed by Robin (1862) in *Chironomus*. He failed, however, to recognize their true nature for he regarded them as polar bodies. Weismann (1863), again in *Chironomus* and also in *Calliphora*, observed not only the separation of these cells from the posterior pole of the egg but also found that they reentered the egg and finally disappeared among the embryonic tissues. He concluded, therefore, that they were not polar bodies and termed them "pole cells" instead. Like Robin, however, he failed to understand their significance. Metchnikoff

(1866) found similar pole cells in *Miastor* and succeeded in tracing them to the larval gonad, thereby indicating their true character. His work was confirmed by later workers, particularly Balbiani (1882) who saw in *Chironomus* not only the constriction of these cells but their reentry into the interior of the egg and incorporation into the gonads as well. All the germ cell work up to this time was done on entire eggs, and with the introduction of modern sectioning and staining techniques, further evidence was accumulated to show that the pole cells are in reality the primordial germ cells. Ritter (1890) especially, again working on *Chironomus*, was able to trace, by means of extensive sections, the development of the germ cells up to the time that they reached their final positions in the gonads of the fully formed larva. Ritter's work was reexamined and confirmed in the main by Hasper (1911). Subsequent to these earlier fundamental studies, germ cells have been discovered in the eggs of a number of other insects. These investigations indicate, however, that the differentiation of germ cells among insects takes place by two general methods. Before comparing these two methods it is necessary to discuss the characteristics of the posterior polar plasm and the role it plays in the origin of the primordial germ cells of hexapods.

Weismann (1863) described what he termed "yolk granules" in the pole cells of *Chironomus*. Ritter (1890), in his study of the germ cells of this same fly by the section method, demonstrated that Weismann's "yolk granules" came from a disk-shaped mass of granular substance located in the periplasm at the posterior pole of the egg. Hasper (1911), in his reinvestigation of Ritter's work, was able to show that this granular substance was incorporated into the cytoplasm of the germ cells. This incorporation of granular plasm by the germ cells has been reported in numerous insects and has led to the belief which is held by some workers that this substance possesses the peculiar power of incorporating itself into the cytoplasm of differentiating cleavage cells and thereby transforming them into germ cells. Hegner, in a series of publications dating from 1908 to 1917, champions this view and terms the granules in question "germ cell determinants."

According to the descriptions of numerous other authors, these posterior polar granules are congregated in a disk-shaped area in the peripheral periplasm at the posterior end of the egg. Gambrell (1933), in discussing this mass of granules in *Simulium*, says that it lies just beneath the surface at the posterior end and appears as a sharply outlined, irregular, and darkly staining body which is completely imbedded in the formative protoplasm. Butt (1934) describes it for *Sciara* as



follows: "At the posterior pole in the periplasm lies a saucer-shaped granular plate, the germinal cytoplasm or germ line determinant." Huettner (1923), in his work on *Drosophila*, used Heidenhain's iron haematoxylin almost exclusively for staining his sections and found that the posterior polar granules stained black like the yolk spheres. Likewise Auten (1934), working on *Phormia*, found that the posterior granular plate stained deeply with Heidenhain's iron haematoxylin. In view of these and other similar observations which appear in the literature, it was expected that a typical disk-shaped area of darkly staining granules would be found at the posterior pole of the flea egg. However, in none of the numerous preparations of pulcid eggs made during this investigation is such an area indicated. The general appearance of the posterior polar plasm of flea eggs has been described in a previous section. In view of the importance of this substance in the differentiation of the germ cells, the following further details are given. At the posterior pole the periplasm is shown to be widened, in a few sections, to form more or less of a cap (pl. 5, fig. 43). This cap is entirely free from yolk spheres. This is its chief distinguishing characteristic, for, in the remaining portions of the periplasm, the yolk structures often appear to extend nearly to the surface. This posterior polar cap is uniformly faintly granular like the rest of the peripheral protoplasm. Furthermore, like the other regions of the egg, it may possess Blochmann's corpuscles. But never in any of the sections prepared for this study does it contain any structures which may be interpreted as corresponding to the darkly staining polar granules of other insect eggs. As previously stated, some of the sections were stained with Heidenhain's haematoxylin and, although the yolk spheres were colored black, there were no similarly stained posterior polar granules present. The remainder of the sections made of the early stages were stained with Delafield's haematoxylin with a counterstain of eosin. Gambrell (1933) used this same combination extensively and found the polar granules clearly indicated thereby. Butt (1934) used Bouin's fluid for fixation, a reagent utilized for the majority of the eggs sectioned in this study, and successfully demonstrated the granular plate in *Sciara*. It may be assumed, therefore, that the fixation and staining techniques employed during the present investigation are favorable to the visibility of posterior polar granules, and their apparent absence in this case may be taken as an indication that such granules do not occur in the eggs of the three flea species under consideration.

This apparent absence of posterior polar granules, however, appears to be not without precedent in the eggs of insects. Nelson (1915), in

his thorough and extensive study of the embryology of the honey bee, makes no mention of the presence of posterior polar granules in the eggs of this insect. He, too, used Bouin's fluid for fixation and iron haematoxylin for staining and found that the yolk spheres stain deeply by this method. As he could hardly have failed to observe a limited posterior polar area of granules had one been present, it may be inferred that the eggs of the honey bee, like those of fleas, lack these particles.

While Hegner's interpretation of the significance of posterior polar granules has been accepted by numerous workers, other embryologists have opposed his view. Huettner (1923), particularly, has taken this position. In 1901 Noack reached the conclusion that these granules are yolk spheres. Huettner, however, demonstrated that this is not the case, and showed furthermore that they are not mitochondria. He also noticed, as Noack had already pointed out, that all of the germ cells do not receive an equal number of these granules. Therefore, in contrast to the germ cell determinant hypothesis, he believes it "probable that the posterior polar granules may be only by-products of the posterior germ plasm and have nothing to do with the determination of the germ cells." In spite of his suggestion that the term be laid aside, some recent workers continue to use it. Du Bois (1932), Gambrell (1933), and Butt (1934), all write of these granules as germ cell determinants. The fact elucidated above, that the eggs of certain insects such as fleas lack posterior polar granules, appears to be conclusive evidence that these structures are not the differentiators of the primordial germ cells.

The two general types of germ cell differentiation in insects are illustrated by *Miastor* and *Drosophila* respectively. In the former, as shown by the studies of Metchnikoff (1866), Kahle (1908), and Hegner (1912 and 1914a), a single primordial germ cell gives rise to all the germ cells of the organism. In *Miastor* the parent nucleus of all the germ cells is differentiated from its fellows in the 8 nucleus stage when it migrates into the posterior polar plasm. Thereafter, this entire polar plasm with its nucleus is cut off from the egg to form the primordial germ cell, which by subsequent divisions produces all the gonial cells of this fly.

In contrast to this single cell origin for all the gonial cells, the majority of insects appear to derive their germ cells by a somewhat different method. In *Drosophila*, for example, as shown by Huettner (1923), a variable number of cleavage cells migrate into the posterior polar plasm and each is constricted off as a primary germ cell. In *Drosophila* this number varies from 6 to 20. In some eggs, the total

number extruded indicates beyond question that they could not all have arisen by the synchronous division of a single primordial germ nucleus. Noack (1901) found the same type of germ cell differentiation occurring in *Calliphora*. In this form 15 to 20 polar nuclei are pushed out posteriorly at one time. Recently, Lassmann (1936) has shown that germ cell differentiation in *Melophagus* is of this type.

In the case of flea eggs, the germ cells develop by a method comparable to that which takes place in *Drosophila*, *Calliphora*, and *Melophagus*. A variable number of cleavage nuclei pass into the posterior polar plasm and constrict off from the body of the egg, surrounded by some of this differentiating ooplasm, to become the first germ cells. Figures 46 and 47 (pl. 5) show several of these completed germ cells lying just within the vitelline membrane. The enlargement for figure 46, showing three germ cells, was made from the whole egg section shown in figure 42 (pl. 4).

Numerous insect embryologists, including Gatenby (1918) working on *Trichogramma*, have shown that the polar nuclei which are destined to become germ cell nuclei can in no way be distinguished from the other cleavage nuclei except by their location in the posterior polar plasm. In the eggs of fleas, all the nuclei present in the egg at this stage are similarly indistinguishable, and because the posterior polar plasm is not demarcated, as in most other insect eggs, by its unique granular appearance, it is impossible to recognize them with certainty. Until they begin to protrude from the egg's surface, one may only assume that the nuclei located nearest to the longitudinal axis of the egg at its posterior pole are destined to become germ nuclei (pl. 5, fig. 44).

Several germ cells make their appearance in the eggs of fleas simultaneously. The first indication of their constriction is the formation of rounded swellings of the egg surface at the extreme posterior pole. Figure 45 (pl. 5) shows three germ cells bulging out preparatory to constriction. In some eggs, such as the one illustrated, the cytoplasm of the protruding cells may possess a granular appearance. The minute structures which are responsible for this appearance are not to be confused, however, with the described posterior polar granules of other insects. Instead, as already stated, they are to be identified as comparable to Blochmann's corpuscles. Their number is negligible in some preparations and profuse in others. Furthermore, unlike polar granules, they are distributed throughout the entire vitelline and periplasmic regions of the egg.

In the discussion on cleavage it was stated that in the eggs of fleas all nuclei entering the periplasm usually arrive there at the same time,

the only exception being that in some cases the most posterior nuclei arrive at the periphery shortly after the others. Judging from their position, these extreme posterior polar nuclei are to be regarded as future germ cell nuclei. Their delayed arrival at the periplasm appears to be at variance with the case of *Drosophila*, for which Huettner (1923) says that the polar nuclei apparently begin their migration a trifle earlier than the preblastema nuclei. As already suggested, the retarded arrival of the posterior nuclei in flea eggs may be ascribed to the fact that in certain cases the fusion nucleus is located somewhat anterior to the center of the egg when it divides.

The first appearance of protoplasmic pockets anticipating the constriction of germ cells, occurs soon after the nuclei have entered the periplasm to form the blastema. This is at the 128 nucleus stage, or following the seventh cleavage division. At this stage, some 15 nuclei are present in the periplasm in a sagittal section. The beginning of germ cell protrusion in flea eggs is relatively precocious when compared with *Drosophila*. In fact, the migration of the preblastema and pregerm cell nuclei is likewise earlier for the fleas than for the pomace fly. In the latter, according to Huettner (1923), it is not until after the next or eighth cleavage division that the nuclei begin to migrate toward the periphery.

The sections prepared for this study show that as the protrusions caused by the first germ cells become more prominent, others which are more lateral in position begin to make their appearance. Even when the most posterior cells are completely constricted, others may be just beginning to bulge out. There is consequently such a gradual transition from the ordinary blastema nuclei to the more median germ cells that it is impossible to determine, with any degree of accuracy, a boundary of distinction between the two types of nuclei. The first germ cells to be constricted appear to become complete during the second blastema substage, or after the eighth cleavage division. Constriction of those more lateral in position may continue into the early part of the third blastema substage following the subsequent or ninth cleavage division. The germ cells then reenter the nucleated periplasm during either the latter part of the third or during the fourth blastema substage before the cell territories of the blastoderm are delimited. Figure 48 (pl. 5) shows the germ cells after their return into the body of the egg. This reincorporation of the germ cells in the blastema surface is in accordance with the recent works of Butt (1936) on *Brachyrhinus*, and of Wray (1937) on *Calendra*, but at variance with the account of Hegner (1909a) for chrysomelid beetles. Hegner states that the germ cells of these insects remain outside the egg body

until blastulation is completed. Their entry later is by means of incompleated points of the blastoderm, termed pole canals. The situation in flea eggs differs likewise from that which Lassmann (1936) has found in *Melophagus*. In this form, the germ cells do not reenter the egg until much later. Instead, they lie for a time in the differentiating annio-proctodaeal cavity and not until this has deepened considerably do they effect an entrance into the embryo.

By counting the total number of germ cells shown in the series from which the section for figure 46 (pl. 5) was taken, there were found to be eight. As a single nucleus, by three consecutive divisions produces eight nuclei, it might be inferred that these germ cells had a mononuclear origin. Such a circumstance could be harmonized with what occurs in such insects as *Miastor* or *Chironomus*. In the latter fly, according to Hasper (1911), a single primordial germ cell protrusion takes place. This divides into two cells as it constricts from the egg, and this division is followed by two others, so that, in all, eight germ cells are produced. If there were always eight such cells formed in flea eggs it might be assumed that they had originated from a single cleavage nucleus which could not be distinguished from the other nuclei in the egg, owing to the absence of posterior polar granules. An examination of other serial sections of eggs of the same stage, however, shows that in fleas the total number of germ cells produced is variable. Some eggs possess as few as 5, whereas others have as many as 12. Reference has already been made to the synchronous division of the cleavage and blastema nuclei. Because of the fact that the germ cells begin to push out as soon as the immigrating nuclei have entered the periplasm, it is apparent that all the germ nuclei were produced by the seventh cleavage. Obviously, therefore, they originated simultaneously with all of the other nuclei present in the egg. It is consequently impossible for any total number (also total progeny) of germ cells numbering between 5 and 15, other than 8 ( $2^3$ ) to be produced from a single ancestral nucleus. The presence of variable numbers of germ cells in the eggs of fleas indicates for them a polynuclear origin.

The further history of germ cells in insects has until now been traced completely only in forms possessing differentiating posterior polar granules. For example, Hegner (1909a) found, for *Calligrapha*, that after reentering the eggs by the pole canals, these cells creep along between the yolk and the germ band to form, eventually, two groups near the developing coelomic sacs. These aggregates acquire follicular envelopes, probably mesodermal, and the gonads are completed. Likewise Lassmann (1936) was able to trace the germ cells of *Melophagus*

to their final position in the larval gonad. In this genus, as already stated, the germ cells lie for a time in the annio-proctodaeal cavity and then pass through the embryonic wall. They then move along on the posterior mesenteron rudiment to the developing gonad.

Although the germ cells of fleas lack posterior polar granules, they are nevertheless distinguishable from the other early cells of the embryo by their larger size, their more prominent nuclei, and the usual clearness of their cytoplasm (pl. 5, fig. 48; pl. 12, figs. 89, 90). They enter the surface layer during the blastema stage, as described, and with the completion of blastulation are to be found incorporated in the blastoderm at the posterior end of the egg (pl. 5, fig. 48). With the appearance of the posterior mesenteron rudiment, the germ cells no longer form a part of the blastoderm, but come to lie on the inner surface of the rudiment (pl. 6, fig. 51). The whole egg section from which this enlargement was made is shown in figure 14 (pl. 2). When the posterior portion of the germ band is involuted into the yolk, the germ cells, together with the posterior mesenteron rudiment, are carried along. At this stage they lie on the embryonic tail at a point near which it is continuous with the amnion. From here they pass, at a later stage, into the epineural sinus where they form two aggregates. The two groups of germ cells move slowly forward, one on each side of the differentiating body cavity, where they are finally incorporated into the gonads as described in a later section.

Of the five workers who heretofore have written on the embryology of fleas, only two have observed the germ cells. One was Balbiani (1875) who, at a later date (1882) published an admirable work on the germ cells of *Chironomus*. In his paper on the development of the cat flea, he describes what he believes to be the germ cells in a stage somewhat later than that in which the embryonic membranes are completed. He says: "The organ of reproduction is already visible in the form of a small mass of clear cells located along the internal aspect of the abdomen immediately below the posterior margin of the vitellus. No envelope or cellular wall surrounds this group of germ cells." The fact that he describes them as clear cells substantiates the identification of the germ cells herein noted as well as the conclusion that the cytoplasm of flea germ cells is lacking in the polar granules common in those of other insects.

While Balbiani saw nothing of the early stages of the germ cells, it is apparent that Packard (1872) actually observed them at the time of their constriction. According to the terminology of his time he called them "pole cells." Although Metchnikoff (1866) had already

indicated the significance of corresponding cells in *Miastor*, Packard was content to state that they disintegrated when he lost track of them. His contributions to this subject are best shown by quoting his statements:

There was observed a vacant space between the yolk and the chorion at the posterior pole, the egg contents completely filling out the opposite end. Also at this time the end of the egg distinctly bulges out, and in this shallow sinus are four distinct polar cells and a small indistinct one in addition, they are distinctly nucleated just as in *Chironomus*. There seems to be a membrane (I suppose the vitelline membrane) retaining these polar cells in place. . . . About two hours later, the vacant space at the posterior pole of the egg has disappeared, and the yolk and protoblastoderm have pushed up against the vitelline membrane and polar cells. In half an hour's time more, the yolk mass has advanced half way to the polar cells. At this time there were no signs of blastodermic cells. A few hours later, probably not over thirty after the egg had been laid, the blastoderm cells had appeared around the yolk. Soon after this the polar cells break down and disappear.

Weismann (1863) does not mention the germ cells in the dog flea eggs which he studied, yet he goes into some detail in his discussion of the "pole cells" which he observed in *Chironomus* and *Calliphora*, the other two insects considered in the same paper. This is accounted for by the fact that the rather opaque chorion in *Ctenocephalides canis* makes it impossible to observe the finer details of structure in whole mounts. As he was unsuccessful in his attempts to remove the chorion without injury to the vitellus and embryo, his discussion of the embryology of fleas is very limited. In *Calliphora*, and *Chironomus* particularly, the chorion is transparent.

It appears that the germ cells of fleas have not been studied by the section method heretofore, although both Tikhomirowa (1890) and Strindberg (1917) used this technique in their investigations on pulcid embryology. The former does not mention the germ cells, while Strindberg says that they are not disclosed in the eggs of *Archacopsylla crinacci*.

#### FORMATION OF THE GERM BAND

At the conclusion of blastulation, the blastoderm cells are equally distributed over the surface of the egg. This condition is characteristic of the undifferentiated blastula. Soon, however, there occurs a concentration of cells toward the ventral midline and polar surfaces of the egg. This crowding of the cells toward the ventral midline is the first step in the formation of the ventral plate which in turn anticipates the germ band (pl. 6, fig. 50). The cells of the median dorsal region appear to be somewhat flattened by the lateral tension exerted upon

them. In contrast, the cells of the future ventral plate, owing to crowding, have elongated and become slightly columnar. The ventral region, therefore, is somewhat thickened. There is, however, no sharp line of demarcation between the thinned and thickened areas (pl. 1, fig. 6). Although somewhat differentiated by cell concentration and a consequential thickening appearing along the ventral surface, the egg is still bounded at all points by a single layer of cells. It is still to be regarded, therefore, as a blastula, and is specifically in the second blastula substage. In fact, another or third blastula substage follows this.

The transformation from the second to the third blastula substage is accomplished by a division of the cells constituting the thickened areas of the blastoderm. This is the eleventh mitotic division, numbering from the zygotic nucleus. The cells of the middorsal thinned region do not appear to participate in this division. Owing to the concentration of the cells in the thickened regions, particularly along the midventral line and its continuation around the poles, some of the nuclei may be forced inward, an illusion of a double cell layer thus being given. A somewhat similar apparently double-layered blastoderm has been described with different explanations in the eggs of certain other insects including *Apis* (Kowalevsky, 1871; Petrunkevitch, 1901; and Nelson, 1915), *Polistes* (Marshall and Dernehl, 1905), and *Phormia* (Auten, 1934).

The multiplication of cells just described results in a still greater thickening of the germ band anlage. This is enhanced further by a change in shape of the cells of the ventral plate. By this change the cells lose their roughly triangular shape, become elongated, narrowed, and truly columnar. The narrowing allows space for the nuclei to reassume a single linear relationship, restoring the single layer appearance.

In contrast to the cells of the thickened portion of the blastoderm, those of the thin dorsal region seem to have remained quiescent and from the surface present a squamous epithelial appearance. Another striking difference between the cells of the two regions is that the majority of the columnar cells possess a large vacuole adjacent to the inner margin of the nucleus. This vacuole is absent in the flattened cells. Nelson (1915) describes a similar stage for *Apis*, but claims that in the development of this insect the thin dorsal strip regains a thickness equivalent to the remainder of the blastoderm, and then once again is reduced to a thin sheet of flattened cells. No such thickening and subsequent rethinning is evident in the eggs of fleas.



The remaining or thickened portion of the blastoderm is termed the ventral plate. As stated, it is thickest along the median line, extending to the anterior pole and somewhat around the posterior pole of the egg. While at first there is no sharp line of demarcation between the thinned dorsal area and the thickened ventral blastoderm, along the midline near anterior and posterior extremities of the ventral plate rather abrupt thickenings soon become evident. These are the first indications of the so-called mesenteron rudiments, which at a subsequent stage will form the midgut epithelium. They represent the first transformations of the single-cell-layered blastula to a multiple laminated condition. Figure 16 (pl. 2) shows the anterior mesenteron rudiment at the beginning of its formation, figure 15 (pl. 2) at a slightly later stage, and figures 23 (pl. 2), 53, 54 (pl. 6), and 25 (pl. 2) at correspondingly still later stages. The early development of the posterior mesenteron rudiment is indicated in figures 14 (pl. 2) and 51 (pl. 6). The details of their later history will be described below.

#### FORMATION OF EMBRYONIC MEMBRANES AND INVOLUTION OF THE EMBRYO

The embryos of fleas, like those of most other higher insects, become covered by two embryonic membranes at an early stage in the development of the germ band. The outer of these envelopes is known as the serosa; the inner one is termed the amnion. Both are cellular in nature and are produced from that portion of the blastoderm which is not involved in the formation of the ventral plate or embryonic rudiment. The amnion is continuous with the germ band, whereas the serosa, although during its formation continuous in turn with the amnion, ultimately loses even secondary connection with the embryo so as to form an entirely independent covering lying just inside the vitelline membrane.

The formation of the embryonic membranes in insects, although fundamentally similar, varies considerably in different forms as to its details. These variations are due to the relationship of the germ band to the vitellus.

The first indication of embryonic membrane formation in flea embryos is the appearance of two shallow indentations of the ventral plate, the beginnings of the amnio-serosal folds. Most authors call these simply the amniotic folds, but because of the dual fates of each, the compound name of amnio-serosal fold used by Wray (1937) has been adopted here.

One of these indentations is anterior in position, being located at a point on the germ band which is somewhat anterior to the location

of the anterior mesenteron rudiment (pl. 2, fig. 23). Because of the extremely long embryonic rudiment that is developed in flea embryos, this anterior depression lies at the anterior pole of the egg. Its anterior margin soon grows out to form a double fold (pl. 6, figs. 53, 54), the anterior amnio-serosal fold. Its inner layer, which is continuous with the ventral plate, will become the anterior part of the amnion; its outer layer is destined to become the anterior portion of the serosa. This anterior amnio-serosal fold, as it increases in length, gradually extends farther laterally (pl. 6, fig. 52), ventrally, and posteriorly. Because of the greater width of the anterior portion of the germ band (pl. 7, figs. 55, 57), due to the presence of the procephalic lobes in that region, the anterior amnio-serosal fold is much wider than the corresponding posterior fold. Posterior to the cephalic region the anterior fold narrows correspondingly to the width of the germ band. This anterior amnio-serosal fold in flea embryos arises in the same manner as do both the anterior and posterior folds in those insects which have the germ band wholly superficial.

The posterior of the two primary amnio-serosal fold indentations occurs on the ventral plate immediately posterior to the posterior mesenteron rudiment. Its position lies somewhat around the posterior pole of the egg toward the dorsal surface. At first the posterior amnio-serosal indentation is identical to that of the anterior fold, but this resemblance is transitory. It is true that the posterior fold is gradually extended forward as its anterior counterpart is extended posteriorly, but in the case of the posterior fold the indentation increases in depth until it extends through the yolk about half way to the anterior pole of the egg (pl. 7, figs. 55 to 57). This extensive deepening of the posterior amnio-serosal indentation carries the posterior portion of the germ band deep into the vitellus. This inward movement of the embryo is to be regarded as a partial involution process corresponding to the extreme type which is characteristic of odonate and hemipteran embryos.

Coincident with the involution of the posterior end of the germ band, the two amnio-serosal folds approach one another (pl. 7, fig. 56), and finally join at the midventral region of the egg. When they come into apposition their intervening walls rupture, and the inner or amniotic layer and the outer or serosal portion of each fuse with the corresponding parts of the other. This fusion occurs during the third day of the embryonic period. In this way there occurs a complete separation of the two embryonic envelopes, producing a double protective covering for the embryo over its ventral surface (pl. 7, fig. 57;

pl. 9, figs. 67, 70). The serosa is formed in part by the outer layers of the amnio-serosal folds and in part by the blastodermal covering over the vitellus. In some insect embryos such as those of *Leptinotarsa* (Wheeler, 1889), *Sciara* (Butt, 1934), and *Brachyrhinus* (Butt, 1936), a small portion of the dorsal blastoderm does not take part in the formation of the serosa. Instead, the cells of this portion clump together dorsally to form the so-called primary dorsal organ which is soon absorbed by the vitellus. In the embryos of fleas, however, no indication of such a primary dorsal organ is apparent, as the entire dorsal blastoderm is incorporated in the serosa. Soon after completion, the serosa becomes separated from the yolk surface and may for a time be observed as an entirely independent membrane composed of extremely squamous cells lying within the vitelline membrane.

In contrast to the serosa, the amnion covers only the surface of the germ band, its margins being continuous therewith. The space between this envelope and the embryo constitutes the amniotic cavity. Its anterior portion is formed by the overgrowth of the anterior amnio-serosal fold, its middle part by a similar growth of the lateral amnio-serosal folds (pl. 6, fig. 52), and the posterior part incorporates the lumen produced by the involution of the caudal end of the germ band (pl. 7, figs. 56, 59, 60). In accordance with the double nature of the posterior portion of the amniotic cavity at this stage, Lassmann (1936) has proposed the significant name of amnio-proctodaeal cavity. This term has been adopted here. It is worthy of note that the embryonic rudiment is not terminated at the inner end of this amnio-proctodaeal lumen as might be expected. Instead, it is continued around ventrally for a short distance before it connects with the amnion.

Histologically, the amnion and the serosa present a similar appearance. Both are composed of extremely flattened cells which, in section, appear as thin spindles. At the center of each such cell is a somewhat expanded area containing the nucleus (pl. 2, fig. 22). In the case of the serosa, as this envelope expands in drawing away from the surface of the vitellus, it becomes further attenuated so that its cells become even more compressed. Neither membrane shows any indications of cell division.

The movements of the germ band in flea development which correspond to the blastokinetic processes of hemipteran and odonate embryos are described at this point. Attention has already been called to the fact that the embryonic rudiment in fleas is partly superficial and partly involuted. At the end of the second day of the embryonic period the involution of the caudal region has reached its maximum, and the

posterior third of the embryo lies completely surrounded by yolk and directed toward the anterior end of the egg (pl. 7, fig. 56). During the next 12 hours, however, there is a withdrawal of the involuted portion from the deutoplasm (pl. 7, fig. 55). This process corresponds to the more complex phase of blastokinesis known as revolution, which occurs in certain other insects, but the details are quite different. In the case of fleas it involves no rupture of the embryonic membranes. Furthermore, instead of withdrawing along the line of involution, the involuted caudal portion of the germ band in fleas merely pulls through the yolk toward the dorsal surface of the egg so that when the process is completed the entire embryo lies at the surface (pl. 10, figs. 73, 74, 75). During the processes of involution and that which corresponds to revolution of other forms, there has occurred a considerable increase in the length of the anterior end of the germ band. At this stage, therefore, it extends entirely around the anterior pole of the egg and is directed posteriorly on the anterior dorsal surface. With the withdrawal of the posterior end of the embryo from the yolk, its anterior and posterior extremities almost touch. The embryo at this stage is about 60 hours old.

#### FATES AND SIGNIFICANCE OF THE EMBRYONIC ENVELOPES

The embryonic envelopes of insects exhibit important differences as to their fates. However, the development of fleas includes a combination of fates for the amnion and serosa which appears to be unique.

Mention has been made of the fact that no structure, homologous to the primary dorsal organ of such forms as *Leptinotarsa*, *Sciara*, and *Brachyrhinus* is found in flea development. Likewise, there seems to be no primary dorsal organ of the type, described by Wray (1937) for *Calendra*, which has nothing to do with the embryonic membranes. Nevertheless, in order to avoid confusion with these two types of dorsal structures, the use of the term primary dorsal organ for the first dorsal body formed in fleas is avoided. Therefore, the first such structure differentiated in siphonapteran development is herein called the second dorsal organ.

In the embryology of fleas the serosa ruptures ventrally early in the fourth day, and is drawn dorsally to form an indistinct clump of cells which lies for a short time on the dorsal surface of the yolk as the second dorsal organ. It is gradually absorbed by the vitellus. This rupture of the serosa and its formation of the second dorsal organ corresponds to the fate of this membrane in the Trichoptera and *Chironomus* (Graber, 1888b). By contrast, the serosa in *Leptinotarsa*

(Wheeler, 1889) and *Calendra* (Wray, 1937) remains intact until the time of hatching.

In flea embryos, the amnion, after the rupture of the serosa, becomes completely detached from the embryo and forms a complete envelope enclosing the egg contents for a time. However, it remains for only a short time after the absorption of the serosa. Then it, too, ruptures ventrally and contracts dorsally to form the third dorsal organ (pl. 2, fig. 24; pl. 11, fig. 79). This occurs toward the end of the fourth day. The third dorsal organ is absorbed by the vitellus immediately before the dorsal closure of the embryo. The rupture and absorption of the amnion is similar to the fate of this membrane in *Leptinotarsa* (Wheeler, 1889) and *Calendra* (Wray, 1937). It differs from what occurs in the Trichoptera and *Chironomus* (Graber, 1888b) in which forms the amnion persists until eclosion. The rupture of both the serosa and amnion in Siphonaptera contrasts with the fates of these membranes in the Lepidoptera (Ganin, 1869) and in the Tenthredinidae (Graber, 1890), in which forms they both persist until hatching.

Strindberg (1917) alone, of those who have written on the embryology of fleas, mentions the fates of the embryonic envelopes. Apparently, however, he was handicapped by insufficient material and was therefore unable to determine the complete sequence of events. He notes that both the embryonic membranes cease to be conspicuous at one stage and then speaks of finding their degenerating cells inside the vitellus a little later. Nevertheless, he states that no dorsal organ is formed, thereby indicating that he missed the significant intermediate stages.

The question of the functional significance of the amniotic cavity to the development of the embryo is one which suggests itself at this point. Wheeler (1889), in discussing this problem for insects in general, regards this cavity as a place for the temporary deposition of excreted matter and therefore as an organ functionally analogous to the allantois of higher animals. He says: "It seems probable that while the inner ends of the ventral plate cells are absorbing and metabolizing the yolk, their outer ends are at the same time giving off into the amniotic cavity a less amount of liquid waste products." This appears to be a logical explanation especially applicable to the development of flea embryos for which Wheeler's hypothesis may be extended as follows: As already stated, the terminal portion of that part of the amniotic cavity which is formed during the involution of the embryo is connected with the proctodaeum to form the amnio-proctodaeal

cavity. The malpighian tubules which serve as excretory organs for the larva have an extremely early origin and arise as invaginations of the proctodaeum (pl. 9, fig. 71). It is possible that they may serve an excretory function in the embryo as well as in the larva. The opening of the proctodaeum into the amniotic cavity is at least significant, especially since in flea embryos the amnion remains intact until the embryonic period is more than half over. When its connections with the embryo are finally broken, the katabolistic products are still prevented from contaminating the deutoplasmic food supply by the provisional covering over the vitellus formed by the second dorsal organ. As the latter is absorbed, the amnion forms the third dorsal organ which in turn blocks the exposed surface of the yolk until the dorsal closure of the embryo. This appears to be the first suggested function for either an amniotic or serosal dorsal organ which has been advanced.

#### GERM LAYER DIFFERENTIATION

Coincident with the formation of the embryonic membranes and the involution of the posterior portion of the germ band, there occurs in the development of flea embryos what corresponds to the gastrulation process of other animals. In fleas, however, as in other insects, the ontogenetic process is so distorted by heterochrony and coenogenetic modification that it is difficult to recognize the relationship of this process to the less specialized and more fundamental method of gastrulation by invagination which is so general throughout the animal series.

The so-called entoderm of insects consists of those embryonic aggregates of cells which go to form the inner lining of the mesenteron. In flea development, these entoderm anlagen are two in number and consist of the mesenteron rudiments which have been mentioned in an earlier section. The appearance of these rudiments marks the initial step in the transformation of the organism from a simple monoblastic to a triploblastic stage. Both rudiments appear simultaneously, immediately following the concentration of the blastoderm cells toward the ventral surface of the egg.

The anterior mesenteron rudiment (pl. 2, figs. 15, 16, 23) originates at a point on the future embryonic midline which is ventral to the anterior pole of the egg mass. The first step in the formation of the rudiment is a change in the general appearance of the blastoderm cells over the region where the rudiment is to appear. Previously, all the cells comprising the ventral and lateral thickened areas of the blasto-

derm, excepting the germ cells, have been columnar in shape. At this stage, however, the cells which are to form the anterior mesenteron rudiment assume an irregularly cuboidal or spherical outline. A similar appearance of the cells comprising the mesenteron rudiments of *Leptinotarsa* (Wheeler, 1889) and *Apis* (Nelson, 1915) has been observed.

The mesenteron rudiments of fleas are not originated by a process of cellular proliferation from the blastoderm such as Carrière and Bürger (1897) have described for *Chalicodoma*. Neither is there an invagination of the blastodermic layer in its formation. Instead, the process is by migration of cells from the ventral blastoderm. With the changes in the appearance of the future mesenteron rudiment cells, which have been described above, the cells themselves tend to become loosely arranged. This loosening results in the appearance of numerous minute interstices between the cells of the rudiment anlage. It is probably responsible for the rounding out of the cells as well. The interstices are not apparent for long, as the cells soon migrate below the surface in an apparently confused mass and then become compactly arranged to form the rudiment proper. The loss incurred by the emigration of cells from the surface is gradually made up by the approximation of the blastoderm over the mesenteron rudiment. For some time previous to this, however, there remains an irregularly outlined and extremely shallow pit (pl. 6, fig. 53) over the mass of cells which may now be regarded as constituting the entoderm. The process up to this time is similar to that found in *Apis* (Nelson, 1915). In flea eggs, however, the shallow pit is finally closed over by the blastoderm (now ectoderm at this point on the surface of the egg mass) in contrast to the case of *Apis*, in the development of which Nelson observed that a plug of mesenteron cells reaching to the external surface remained after the approximation. In spite of the fact that it completely covers the rudiment of the mesenteron, the ectodermal sheet over this area in flea ova may be slightly indented to form a second shallow depression which is to be recognized as the location for the stomodaeal invagination.

While there is no evidence that cell proliferation has played any part in the formation of the anterior mesenteron rudiment up to this time, subsequently the rudiment increases in thickness by the multiplication of its cells. This is shown by the presence of mitotic figures among the cells of the lower portion of the entoderm mass. The anterior margin of this anterior mesenteron rudiment is thinned out rather abruptly and terminates at a point which is located slightly

posterior to the point of origin of the developing amnio-serosal fold. The short interval of undifferentiated blastoderm which separates the two is some dozen cells in length (pl. 2, fig. 25; pl. 6, fig. 54).

The origin of the posterior mesenteron rudiment, although essentially similar to that of its anterior counterpart, differs in certain details. The region of appearance in this case is dorsal to the pole rather than ventral. Furthermore, the length of the blastoderm concerned in its formation is considerably greater. The initial manifestation of the formation of the posterior mesenteron rudiment is a thickening, accompanied by a flattening of the blastoderm slightly dorsal to the posterior pole of the egg (pl. 2, fig. 14; pl. 6, fig. 51). Owing to the later involution of the posterior portion of the germ band, the anlage of this rudiment is drawn from its place of origin to a point yet farther around the posterior pole of the egg. The greater length of the posterior rudiment, as contrasted to the anterior one, is noticeable at all stages in its development. Furthermore, its margins on all sides are less abrupt. Although the posterior rudiment tends to be somewhat thinner than the anterior rudiment at corresponding stages of development, it ultimately attains an equivalent thickness. This thickening takes place during the later phases of the involution of the germ band and is not completed until the tail of the embryo has reached the center of the egg. Figures 59 and 60 (pl. 7) show this aggregate of mesenteron cells lying immediately within the ectoderm adjacent to the posterior terminus of the amnio-proctodaeal cavity. Although a short portion of the ventral plate is continued around this terminus to connect with the amnion, the cells of the posterior mesenteron rudiment are not included in this extension.

The appearance of the two mesenteron rudiments marks the first step in the differentiation of the germ layers in flea development, but there soon follows a change in the nature and thickness of the remaining parts of the ventral plate. This consists of the process usually called gastrulation. In the development of fleas, as of other insects, this process results in the transformation of the blastoderm into a double-layered germ band. The superficial layer in this case is continuous with the sheets which cover the two mesenteron rudiments and like those coverings is to be regarded as ectoderm. The lower layer is continuous with the mesenteron rudiments, there being no sharp line of demarcation between either of them and this lower layer. Because of the part played by this lower layer in the organogenesis of the embryo, it is to be identified as mesoderm.

The differentiation of the blastoderm of the ventral plate region in that section between the mesenteron rudiments is not identical in



all insects. An examination of the literature reveals descriptions of gastrulation in insects by the four following methods:

1. The lower layer is formed by an emigration or proliferation of cells from the blastoderm along the median line of the ventral plate. No obvious median groove is produced to assist in this process; in some instances all indications of such a groove are lacking. Korschelt and Heider (1899) discount the reports of the existence of this type, apparently because of their conviction that a tube, or groove at least, must be present as the remnant homolog of the gastrula-tube of other animals. There is no doubt, however, that such a method of lower layer formation actually exists in some insects. It has been observed by Heymons (1897) in *Lepisma* and by Uzel (1898) in *Campodea*. It is also described for the Collembola by Claypole (1898), Philpitschenko (1912), and Weber (1933). In addition, it has been reported in several of the Pterygota by a number of workers including Korotneff (1885) for *Grylotalpa*, Wheeler (1889) for *Blatta*, and Hagan (1931) for *Hesperoctenes*.

2. The lower layer arises by an emigration of cells from the blastoderm along the median line of the ventral plate. In this case a distinct groove is formed, but its lips are not approximated to form a tube. This method has been described by Patten (1884) for Trichoptera, by Will (1888) for Aphidae, and more recently by Gambrell (1933) for *Simulium* and by Auten (1934) for *Phormia*.

3. There occurs an actual invagination of the ventral midline blastoderm to form a groove which changes into a closed tube by the approximation and fusion of its lips. This type of lower layer separation has been reported in several of the higher insects such as *Hydrophilus* (Kowalevsky, 1871, Heider, 1885 and 1889), *Leptinotarsa* (Wheeler, 1889), *Chalicodoma* (Carrière, 1890), *Calliphora* (Kowalevsky, 1886), and *Calendra* (Wray, 1937).

4. The middle portion of the ventral plate becomes separated from the lateral blastoderm. This middle plate then sinks inward while the lateral plates grow together and fuse over its outer surface. Like the third type described, this method has been reported only for certain higher insects. Among them are *Apis* (Nelson, 1915), *Sphinx* (Kowalevsky, 1871), and *Pieris* (Bobretzky, 1878).

In fleas the lower layer is produced by a combination of the first three methods listed above. In the anterior third of the ventral plate, including the brief section between the anterior mesenteron rudiment and the anterior annio-serosal fold, there is a simple emigration of cells from the blastoderm, without the formation of a perceptible

groove (pl. 8, fig. 61; pl. 2, fig. 17). There is no proliferation of cells from the blastoderm by mitotic division such as Wheeler (1889) describes for *Blatta*. Instead, there is merely a sinking of the cells which are located at the midline. In certain cases this appears to be an irregular process similar to that which has been described for the formation of the mesenteron rudiments. Especially is this true in the region adjacent to the anterior rudiment where the transition from the cells of the lower layer to those of the rudiment is difficult to make out. Posteriorly, the migration of cells appears to become more regular. At the beginning of the second third of the ventral plate there is a gradual transition from this first method of lower layer formation to the second type which has been described above, viz, that in which the migration of cells is combined with the formation of a groove (pl. 8, figs. 62, 63, 64). This method is followed throughout the major portion of the germ band, and the groove is shallow in all places. The cells which form the sides of the groove are destined to form the lower layer. These cells separate from those which are to form the ectoderm, the breaks occurring at the points where the blastoderm turns in to form the walls of the groove. In the meantime, the sides of the groove approximate, but never to form a tube. In some cases the mesoderm-forming cells migrate to the lower layer level in two parallel columns. At a point somewhat ventral to the posterior pole of the egg, the groove deepens abruptly. From this region on to a position only slightly anterior to the posterior mesenteron rudiment, the sides of the groove widen out below the surface layer, after which the lips of the groove approach one another and fuse to form a true tube with a distinct lumen (pl. 2, figs. 18, 19; pl. 8, fig. 65). In the relatively short region at the posterior end of the embryo, between the posterior mesenteron rudiment and the section of the germ band where a tube is formed, a simple groove is again produced, the sides of which appose as in the middle embryonic region. Along the short length of germ band which forms the posterior extremity of the embryo and which is carried around the terminus of the invaginating proctodaeum, the method of lower layer formation is identical to that which occurs in the anterior third of the egg (pl. 7, fig. 58).

It has been stated that in the formation of the lower layer of flea embryos, proliferation of cells from the blastoderm does not play a part. Instead, the sunken cells arrange themselves so as to form a relatively simple row the full width of the germ band below the ectoderm (pl. 9, figs. 69, 70). The details of this process vary according

to the method by which the cells of the lower layer reach their submerged positions. In the anterior region of the embryonic rudiment where the cells sink by an irregular migration, this lateral progress is likewise by an apparently haphazard movement (pl. 9, fig. 67). In the section where the shallow groove is formed and in those regions of it in which the mesoderm-forming cells migrate in parallel columns, these lines of cells separate sharply at the lower level midline and pass in opposite directions toward the lateral limits of the germ band (pl. 8, fig. 64; pl. 9, fig. 69). This is in agreement with the observations of Patten (1884) on *Necophylax*. In connection with that portion of the embryonic rudiment where a distinct mesodermal tube is formed, the beginning of the process is identical with that in which no groove is formed. The first cells to leave the surface pass inward with no space between them. The invagination takes place above this solid mass so that the lower wall of the tube, when it is completed, is two cells thick (pl. 8, fig. 65). With the compression of the tube to obscure its lumen, these lower cells separate and migrate laterally to form the extreme marginal parts of the unproliferated lower layer. Figure 66 (pl. 8) shows this stage in a section cut at a level slightly posterior to that from which the one shown in figure 65 was made.

In the three forms of lower layer formation which occur in the development of the flea embryo, it is evident that the first cells to leave the surface tend to form the most lateral portions of the mesoderm. The relative positions of the cells in the lower layer with respect to the midline are obviously the reverse to what they were when these same cells were still a part of the blastoderm. This situation is the direct opposite of that occurring in *Apis* as described by Kowalevsky (1871) and Nelson (1915). Although the lower layer, when first formed in fleas, is typically only one cell in depth, it is soon thickened by cellular proliferation. This is shown by the mitotic figures which are evident among the mesoderm cells.

Of the five workers who have written on the embryology of fleas, only those two who used the section method of study have mentioned the germ layers. These are Tikhomirowa (1892) and Strindberg (1917). However, the statements of both of them in this connection are inaccurate. In respect to the origin of the lower layer (mesoderm) Strindberg omits its consideration entirely, confining his remarks to the mesenteron rudiments. He merely states that in *Archacopsylla crinacci* the epithelium of the mesenteron is derived from one anterior and one posterior anlage originating from the lower layer. Since the mesenteron rudiments of the forms investigated during this study

make their appearances as differentiated areas of the blastoderm before the lower layer is produced, his observation appears to have been in error.

While Tikhomirowa (1892) discusses the origin of the mesoderm at considerable length, her ideas are also inaccurate. Her paper is primarily a criticism of Patten's article on the embryology of *Neophylax* (1884) in which he describes the mesoderm as originating from cells which migrate inward from the midventral blastoderm, the same method as has been described above for the middle region of the germ band in the case of fleas. Tikhomirowa did not base her observations on any of the Trichoptera, but insisted that, contrary to Patten's observations, it must arise in *Neophylax* in the same manner she claimed to observe it originate in the flea and in *Chrysopa*. She is emphatic in her assertions that in both of these insects the mesoderm, and the lining of the mesenteron as well, are derived from the yolk cells (trophonuclei). Her views on this subject are clearly described in a translation of her own words:

In summing up my observations on the formation of the ectoderm and primary entoderm, viz, the blastoderm and yolk cells respectively, . . . I must contend that here the process is different from that described by Patten in regard to the phryganids which he studied. In examining his figures and comparing them with my own, I find a great deal of resemblance between them. For this reason, it seems to me that that author was mistaken in affirming that all the cleavage cells go into the formation of the blastoderm. It is very possible that he did not notice the negligible number of segmentation elements which remain in the interior of the vitellus at the beginning of the formation of the blastoderm and which remain in the center multiplying rapidly and giving rise to the primary entoderm. In regard to the formation of the mesoderm I have several series of slides which show definitely that its cells are derived from the primary entoderm (vitelline cells). If we should study one of the preparations representing the germ band, we would remark that the primitive groove is very indistinct, so that in this stage there is not the slightest possibility of the separation of a part of the ectoderm (blastoderm) for the formation of the mesoderm. In sections of eggs of the same stage, we see that the mesoderm is very distinctly set off from the ectoderm. Directly below the ectoderm are situated cells of the mesoderm, one right next to the other. Here we can follow clearly all the transitions of the nuclei of the primary entoderm, or rather of the nuclei of the vitelline cells, by their size, form, and coloration, even to the mesoderm close by. On this point, also, my observations differ from those of Patten who states for the phryganids that all the mesoderm is derived from the blastoderm cells in the region of the primitive groove. . . . I find in the earlier as well as later stages of *Pulex serraticeps*, incontestable proof of the fact that the mesoderm is derived from the primary entoderm or vitelline cells. The series of slides of *Pulex serraticeps* which I possess, shows the formation of the mesoderm from its initial stage and proves beyond doubt that the first cells of the mesoderm are nothing else than the cellular elements remaining behind in the interior of the egg after the

formation of the blastoderm and which approach little by little and one after the other to finally touch the blastoderm from underneath. The irregular form, the largeness and the pale color of the nuclei of the first mesoderm cells show a perfect resemblance to the primary entoderm cells on the one hand, and their absolute dissimilarity regarding the same characteristics to the cells of the ectoderm on the other. I believe, therefore, that the origin of the mesoderm from the primary entoderm in *Pulex serraticeps* is beyond doubt.

This quotation serves to illustrate the fact that the literature of insect embryology contains many errors. Frequently, as in the present case, the development of a certain form has been reinvestigated with opposite results, causing one to doubt the accuracy of much that has been written in this field. Such discrepancies are apparently due, in a large measure, to the difficulty of the technique involved. Fragmentary or otherwise poor sections prompt misinterpretations. The failure of Tikhomirowa to observe the origin of the mesoderm from the blastoderm may be ascribed to faulty preparations. It is a different matter, however, when one considers her derivation of the entoderm from the vitellophags. The origin of the cells which go to form the mesenteron epithelium has been one of the most debated questions concerned with insect development. In deriving the functional entoderm from the trophonuclei Tikhomirowa was merely following the lead of numerous other investigators of her period. Their opinions were doubtless motivated by a desire to harmonize the origin of the germ layers in insects with the germ layer theory and with what was known to occur in other groups. In the majority of animals the entoderm is differentiated with the formation of the gastrocoel by invagination. Consequently, in such forms the entoderm lies at the interior of the egg. These workers expected, therefore, to find the entoderm cells originating from the nuclei contained in the yolk. It has been pointed out already that in other insects, as well as fleas, the primary trophonuclei are augmented by cells migrating into the yolk after the completion of the blastoderm. Dohrn and his followers, seeing such cells intermediate between the vitellus and the surface layer, probably mistook the direction of their progress and added this observation to substantiate their belief. It may have been an attempt to carry the germ layer theory one step farther that prompted Tikhomirowa to derive the mesoderm from the same source as that from which she supposed the entoderm originated.

The mesenteron rudiments of flea embryos have been described in the present paper as originating from near the anterior and posterior extremities of the ventral plate blastoderm, making their initial appearance before the formation of the lower layer is evident. Such a

derivation, independent of the mesoderm, is not new to the literature of insect embryology. In 1897 Carrière and Bürger described such a method of entoderm origination in both *Chalicodoma* and *Tenebrio*. Noack (1901) says that in *Calliphora* the entoderm cells are produced in the same manner. It is of interest to note that Uzel (1897a, 1898) states that the entoderm of the apterygote forms *Lepisma* and *Campodea* is likewise formed from cells which migrate in from the blastoderm. Philiptschenko (1912) describes the same origin for *Isotoma*. However, in these last two cases, in addition to the anterior and posterior rudiments, entoderm is proliferated along the embryonic band.

#### EXTERNAL EVIDENCES OF SEGMENTATION AND CHANGES IN EMBRYONIC SHAPE

Very early in the development of flea embryos, at the beginning of the second day and even before the differentiation of the germ layers, there becomes evident what appears to be a precocious segmentation of the ventral plate. The manifestations of this pseudosegmentation take the form of incomplete transverse zones of the ventral blastoderm. They are incomplete in that the middle portion of the plate (consisting of the cells of the future mesoderm) is unaffected by this phenomenon. At first it appears that these precocious divisions correspond to the primary segmentation of the insect germ band which was first observed by Ayers (1884) in *Occanthus* and later by Graber (1888a, 1890) in a number of different insects. These authors were able to distinguish four general regions in the early germ band. They were a primary cephalic, a maxillary, a thoracic, and an abdominal region. Graber attributed great phylogenetic significance to these divisions which he regarded as the primary body segments. Accordingly, he termed them macrosomites in contrast to the definitive body segments or microsomes into which they subsequently divide.

Careful examination of flea embryos indicates that these general zones are more numerous than the four regions observed by Ayers and Graber. In fact their number is not constant and what is more, they soon disappear. Therefore, they are to be regarded as pseudosegments which are due to some other factor than segmentation, perhaps a mechanical contraction. Wheeler (1889) describes a somewhat similar phenomenon in *Leptinotarsa* and ascribes it to a wrinkling of the ventral plate. The fact that such segmental appearance is not evident in longitudinal sections of flea eggs of this stage substantiates this explanation.

The true segmentation of the germ band of fleas does not take place until the third day of development when the germ layers are completely differentiated and revolution has taken place. This circumstance differs, therefore, from that which occurs in other insects such as *Hydrophilus* (Kowalevsky, 1871), *Chalicodoma* (Carrière, 1890), and *Apis* (Nelson, 1915), in which the definitive segments are marked off even before the lower layer is formed.

Preliminary to the segmentation of flea embryos, therefore, the double-layered germ band is produced. A description of this process as seen in sections has already been given. However, an understanding of its superficial appearances is requisite to the description of the external manifestations of segmentation. The superficial indications of the germ band become evident during the second day of development. The first of these consists of a flattening of the middle portion of the ventral plate preliminary to the immigration of its cells to form the entoderm and mesoderm. Next, the anterior region of the ventral plate expands perceptibly. This is coincident with the lateral expansion of the mesoderm. Evidencing this is the fact that the germ band becomes distinctly more opaque than the lateral regions of the blastoderm which are destined to form the embryonic envelopes. The lateral expansion of the anterior part of the germ band serves to differentiate the embryonic rudiment into two general regions (pl. 7, figs. 55, 57). The expansions of the anterior shorter one are the procephalic lobes (pl. 9, fig. 68). The longer narrower portion is the protocornic region. When the procephalic lobes first make their appearance, they are situated somewhat ventrad to the anterior pole of the egg. With the lengthening of the germ band, however, they come to lie dorsad to this pole, in which position they are to be found at the middle of the third day of development. At this time the caudal portion of the embryo has completely withdrawn from the yolk and the two ends of the germ band almost touch.

In some insects there is a pronounced difference in time between the appearance of the anterior and the posterior segments of the germ band. Those of the cephalic region have been reported to appear earlier in the majority of forms. Schmetter (1934) for *Apis* and Butt (1936) for *Brachyrhinus* have found that segmentation is initiated, not at the extreme anterior end, but in the future thoracic region from which point it extends both anteriorly and posteriorly. In flea embryos the difference in the time of appearance of the segments in the various portions of the germ band is negligible, but the anterior-posterior sequence is followed in this discussion for the sake of convenience. The procephalic lobes become divided into three

segmental regions. The most anterior of these soon develops a bilobed prominence which is the anlage of the labrum (pl. 3, fig. 34; pl. 10, fig. 75; pl. 11, fig. 82). It is known as the labral, ocular, or preantennal segment. The second segment gives rise to the prominent paired antennae and is therefore termed the antennal segment. The third procephalic segment, which really arises in the region of transition between the procephalic and protocornic regions, is much less prominent. It does, however, produce a pair of small evanescent rounded protuberances which may be regarded as homologs of the second antennae of crustaceans. The protocornic region gives rise to 17 segments plus an additional incomplete one which is to be regarded as the telson. The first three of these are called the gnathal segments as they produce appendages which are differentiated into the larval mouthparts (pl. 10, fig. 74). The most anterior is the mandibular segment and, as its name indicates, its paired appendages form the mandibles. Similarly the second or maxillary segment gives rise to the maxillae, and the third or labial segment produces the labium. This organ arises as a pair of appendages (the second maxillae) whose bases soon fuse to form the bilobed labium of the larva.

The three procephalic and the three protocornic segments described above soon lose their lines of demarcation and become closely fused to form the syncephalon of the developing larva. By contrast, all the remaining protocornic segments, except the most caudal one, retain their external identity even to the end of the larval period. The three segments immediately posterior to the gnathal ones become the prothoracic, the mesothoracic, and the metathoracic segments respectively.

The 11 segments of the protocornic region situated caudad to the thoracic region constitute the abdomen. The eleventh, which is considerably smaller than the rest, does not remain visible from the outside for long as it is soon carried inward by the invagination of the proctodaeum and becomes telescoped within the tenth segment.

The general changes in body shape may be outlined at this point. After 3 days of development, the germ band is so curved dorsally that the anterior and posterior ends nearly touch (pl. 10, figs. 73, 74, 75). During the fourth day the embryo shortens so that it reaches only to the poles of the egg. The two extremities of the embryo are still turned dorsally, however, and they remain so flexed until early in the fifth day, when the embryo straightens out and then curves ventrally (pl. 12, fig. 87). Coinciding with this ventral flexure, there is gradually an elongation of the embryo until it is so long that the curvatures of the ends are insufficient to allow its accommodation within the egg.



The anterior and posterior extremities, therefore, become so flexed that a cross-section of the egg may cut four complete sections through the embryo. The embryo retains its curled position until the time of hatching, after the sixth day of development.

#### DIGESTIVE TRACT

The fore-intestine, comprising the oesophagus and proventriculus in the late embryo, has its origin, in fleas as in other insects, in an ectodermal invagination known as the stomodaeum. This invagination arises directly over the position of the anterior mesenteron rudiment, becoming evident soon after the ectoderm has closed over the sunken entoderm. The stomodaeum deepens very gradually, keeping pace with the shrinkage of the yolk. As it deepens it pushes the entoderm of the anterior mesenteron rudiment before it. It ultimately extends posteriorly about one fourth of the length of the egg (pl. 3, fig. 34; pl. 10, fig. 75; pl. 11, fig. 82).

The hind-intestine arises in a somewhat similar manner although there are several differences to be noted. Like the fore-intestine, it is derived from an ectodermal invagination which in this instance is termed the proctodaeum (pl. 3, figs. 35, 36; pl. 10, fig. 75). It may be said that the relationship between the proctodaeum and posterior mesenteron rudiment is fundamentally the same as that which exists between the stomodaeum and anterior entodermal rudiment. In the case of the proctodaeum and posterior mesenteron rudiment, however, the relationship is made more obscure in the earlier stages of development by the involution of the posterior region of the germ band. The point at which the embryonic band sinks inward during this process is almost immediately over the position of the posterior mesenteron rudiment and therefore somewhat anterior to the posterior extremity of the germ band. This is also the point at which the proctodaeum is pushed inward so that the first part of the resulting invagination to form appears to belong to both the proctodaeum and the amniotic cavity and has consequently been termed the amnio-proctodaeal cavity. However, since this first portion of the cavity of the invagination is bounded on both sides by the embryonic rudiment, it is definitely the lumen of the proctodaeum. Only later, as the involution of the posterior part of the germ band becomes more pronounced, is a portion of the extra-embryonic blastoderm drawn into the vitellus to form the internal (with reference to the yolk) section of the amnion (pl. 7, figs. 56, 59). That part of the cavity which is bounded on one side by the amnion is the only portion of the entire invagination which

belongs to the amniotic cavity alone. Its wide continuity with the lumen of the proctodaeum is responsible for the confusion of embryologists on this point. None of the five workers who have published on the embryology of fleas considers this relationship, but there is considerable difference of opinion among the authors who have written on the development of other insects possessing a partially involuted germ band. Weismann (1863) and Ritter (1890) both confuse the line of demarcation between the amniotic cavity proper and the proctodaeum. Other investigators working on the muscids, including Graber (1888b), Bütschli (1888), Voeltzkow (1889), and Noack (1901), have made the same mistake. This error has been in the proper interpretation of that portion of the germ band which lies opposite the main part of the embryonic rudiment and which is continuous with the amniotic membrane. The above authors agree in regarding this short strip as a part of the amnion, and consequently suppose that the amnion forms one of the walls of the proctodaeum. Their identification of the early stage of the proctodaeum is, nevertheless, correct. Other workers, however, among whom are Hasper (1911) for *Chironomus*, Gambrell (1933) for *Simulium*, and Butt (1934) for *Sciara*, have not found the proctodaeum in this early stage. For this reason, they all state that the stomodaeum is discernible much earlier than the proctodaeum.

In the development of flea embryos, the early stages of the proctodaeum are less obscure, owing to the fact that observation is not further complicated by the tendency of the posterior portion of the germ band to roll into a spiral as it is in the dipterans mentioned above. In fleas, therefore, it is possible to follow the development of the proctodaeum from the time of its first appearance. This appearance is simultaneous with that of the stomodaeum and with the involution of the posterior part of the embryo. With the withdrawal of the posterior end of the germ band from the yolk to the dorsal surface of the egg, the proctodaeum already shows a tendency to become directed anteriorly, for at this stage it is perpendicular to the adjacent part of the embryonic rudiment (pl. 10, fig. 75). In respect to the embryo it is now pointing dorsally instead of posteriorly as before. The majority of the posterior mesenteron rudiment cells lie anterior to it (toward the posterior pole of the egg) at this stage.

The hind-intestine of the late embryo is not a straight tube. It extends anteriorly from the anus to about the anterior margin of the sixth segment and then curves ventrally upon itself and passes posteriorly to the region of the eighth segment. Here it again turns sharply ventrally and anteriorly to unite with the mesenteron. The

elongated nature of the hind-intestine becomes evident rather early in development. As a consequence of this elongation, the proctodaeum, unlike the stomodaeum, soon becomes coiled and at some stages is curved somewhat laterally to the midline. This is evidenced by the fact that certain sagittal sections, as well as transverse ones, cut the proctodaeum at more than one place (pl. 11, figs. 80, 84). Strindberg (1917) pointed out this elongated nature of the proctodaeum in his brief paper on *Archacopsylla*. He also notes that the hind-intestine is considerably thickened near the anal opening, and that it is one of the most conspicuous of the embryonic organs.

Associated with the hind-intestine are the malpighian tubules. There are four of these formed in the flea embryo. As in other insects, they arise as diverticula of the proctodaeum proximal to its blind end. Their first evidences make their appearance rather early, in fact while the proctodaeum still lies perpendicular to the germ band. By the time the proctodaeum becomes directed anteriorly they may be easily seen (pl. 9, fig. 71). They grow very rapidly and soon show as thick-walled tubes in cross-section (pl. 3, fig. 32; pl. 11, fig. 84), lying laterad to the developing hind-intestine. Their blind ends remain free in the haemocoel.

The mesenteron derives its inner lining from the two entodermal rudiments whose differentiations have been described in a previous section. As in the majority of insects whose embryology has been studied, this epithelium is entirely bipolar in origin, in contrast to the condition described by Strindberg (1913) for Isoptera, in which he says the mesenteron rudiment is single and proliferated from the entire length of the germ band. This same author (1917), however, derives the entoderm of fleas solely from an anterior and a posterior mesenteron rudiment. His error in deriving these rudiments from the lower layer has already been pointed out.

With the shrinkage of the yolk and the invagination of the stomodaeum and proctodaeum, the two entodermal rudiments are carried into the interior of the embryo. At first they lie as small clumps of cells against the blind ends of the ectodermal invaginations which have pushed them inward. Because of this apposed relationship to the ectoderm, many workers have come to the mistaken conclusion that the inner lining of the midintestine is ectodermal in its derivation.

The mesenteron rudiments, as already stated, lie slightly ventrad to the blind ends of the stomodaeum and proctodaeum. From each rudiment there is proliferated a pair of laterally placed tongue-like processes, those of the anterior rudiment directed posteriorly (pl. 11, figs. 81, 83), and those of the posterior one directed anteriorly. These

are the mesenteron ribbons. The ribbons of each side gradually approach one another and fuse, forming a complete band of entoderm connecting the stomodaeum and proctodaeum (pl. 11, fig. 80). The two bands formed in this manner then widen gradually both dorsally and ventrally. Their ventral growth is much more rapid than their dorsal expansion, and as their initial position is somewhat ventral, they meet and fuse ventrally first so that the closure of the ventral wall of the midintestine occurs considerably earlier than its dorsal closure. The dorsal closure is delayed until the third dorsal organ, composed of the massed cells of the ruptured amnion, has sunk into the vitellus (pl. 2, fig. 24; pl. 11, fig. 79). Then the dorsal margins of the widened mesenteron ribbons fuse along the dorsal midline and the epithelial lining of the midintestine is completed.

The method of the enclosure of the vitellus by the cells of the entoderm as here described for flea embryos corresponds essentially to that which has been described for all other insects thus far studied, possessing bipolar entodermal rudiments, except *Apis*. In the honey-bee, by contrast, and according to the observations of both Grassi (1884) and Nelson (1915), the two mesenteron rudiments each form a median dorsal ribbon instead of a pair of ventrolateral ones. This results in the dorsal surface of the yolk being covered first.

The final steps in the embryological development of the intestinal tract of fleas are the breaking through of the blind ends of the stomodaeum and proctodaeum to make the lumen of the digestive tube continuous from the mouth to the anus, and the investiture of the entire tract with its muscular layer.

#### NERVOUS SYSTEM

Very soon after the separation of the lower layer cells from the ectoderm, the neural groove appears along the entire midventral line of the embryo (pl. 9, figs. 69, 70). This is the first step in the development of the nervous system, all of which is produced by the ectoderm. The neural groove makes its appearance even before the first manifestations of the cephalic appendages. Instead of originating by invagination, the neural groove appears to be produced by two longitudinal thickenings of the ectoderm, one on each side of the midline of the germ band (pl. 10, fig. 78), the median unthickened portion becoming the groove. The two ridges continue the full length of the germ band, one passing laterally on each side of the depression which marks the position of the stomodaeal invagination. They are continued, therefore, on the cephalic segments and unite in the head

region. The appearance of the neural ridges is due to the active proliferation of specialized ectodermal cells below the surface layer. These primary nerve cells are called neuroblasts (pl. 9, fig. 72). The neuroblastic thickenings along the lengths of the neural ridges constitute the so-called lateral cords. Neuroblasts are also proliferated from the floor of the neural groove, and these form the less prominent middle cord.

With the segmentation of the germ band, all of its layers are affected except the entoderm. By this process the lateral nerve cords are metamERICALLY constricted into segmental divisions. The superficial layer of ectoderm over the neuroblasts gives rise to the epidermis; therefore its cells are called the dermatoblasts (pl. 9, fig. 72). The neuroblasts on the other hand proliferate the definitive nerve cells. Those of the lateral cords are particularly active in the intrasegmental regions where they give rise to the masses of nerve cells constituting the ganglia. Because of the fact that the lateral cords are paired, two ganglia are produced in each segment. The ganglia of successive somites are joined by the less thickened interganglionic portions of the lateral cords, the connectives. Figure 27 (pl. 3) shows the fused paired ganglia and their connectives in horizontal section, and likewise indicates that the two ganglia of such a fused pair are transversely connected by two commissural neuropile tracts. These commissures appear to be formed from ganglion cells proliferated by the neuroblasts of the middle cord. The paired nature of the commissures of a fused ganglionic pair is shown clearly by the two neuropile tracts in each such definitive ganglion (pl. 12, fig. 85). From its first appearance, this middle cord is segmented into chainlike thickenings of neuroblasts which correspond in position to the future ganglionic areas. They are strictly intrasegmental, therefore, so that there are no median intersegmental connections produced between the connectives, such as Wray (1937) describes for *Calendra*. In this respect the development of flea embryos corresponds to Schaefer's (1938) observation on *Phormia*. The neuropile of fleas, or the central mass of fibrous tissue which is evident in the nerve tracts, appears to be composed of the attenuated ends of the ganglionic cells closely packed together.

Later in embryological development, as described above, the two ganglia of each segment become approximated to fuse closely at the midline with the commissures and thus form a composite definitive ganglion. The connectives retain their individuality, however, thus preserving intersegmental evidence of the bilateral origin of the ventral nerve cord.

The above account agrees quite closely with the observations of Hatschek (1877) who pioneered in the embryological study of the nervous system of insects, and also corresponds to the writings of most insect embryologists. No observations were made in the present study on the origin of the delicate ganglionic covering, the neurilemma. Wheeler (1893) for *Xiphidium* and Eastham (1930) for *Pieris* are of the opinion that it is produced by cells of the middle cord.

The ganglionic swellings remain evident on the surface until about the end of the fourth day of development. Their disappearance is gradual and is due to the sinking of the ganglia to a lower level (pl. 3, fig. 26; pl. 12, fig. 87). This sinking also serves to obliterate the neural groove.

The central nervous system of a flea embryo consists of 19 pairs of ganglia. Figure 87 (pl. 12) shows the complete nerve chain, the thoracic and abdominal ganglia having retained their identity, while the cephalic ones are coalesced as described below. The first two of these go to form the greater part of the definitive brain or supraoesophageal ganglion. The anterior pair, which at first forms the independent protocerebral lobes, soon unites to form the bilobed protocerebrum of the ocular segment. An apparently single commissural mass connects the two halves of this neuromere. The component parts of the second pair of cephalic ganglia likewise fuse to form a bilobed neuromere which in this case is known as the deutocerebrum. It has as its function the innervation of the antennae. It also has a single commissure. These first two pairs of ganglia are the only ones of the entire nerve chain which have their origins anterior to the position of the stomodaeal invagination. Although the lateral cords continue anteriorly to this region, the proliferation of the ganglion cells of the protocerebrum and deutocerebrum is difficult to follow. In this area the proliferation is very irregular. The origin of the commissures of these neuromeres was not determined definitely, but no indication of a middle cord was evident anterior to the stomodaeum. This last observation is in agreement with the account of Schaefer (1938) for *Phormia*. It seems, therefore, that the connecting cell masses do not have an independent origin in these cases but are produced merely by the approximation and fusion of their respective pairs of ganglia.

The brain of the flea embryo, like those of other insects, includes a third pair of ganglia, which has a different origin from those of the first two segments. This pair is derived from the lateral cords just posterior to the stomodaeal invagination. Because of this origin, therefore, the elements of this pair are to be regarded as ventral ganglia

which secondarily move anteriorly and dorsally to unite with the deutocerebrum and protocerebrum in the formation of the supraoesophageal ganglion or definitive brain which lies dorsad to the oesophagus (pl. 12, figs. 87, 88). This ventral origin is evidenced by the fact that the transverse commissures (fused so as to appear one) pass below the oesophagus (pl. 12, fig. 86). Ventrally, they unite with the connectives of the most anterior of the trunk ganglia and in this way help to form the so-called circumoesophageal connectives. This third pair of cephalic ganglia appears as paired swellings lying immediately posterior to and below the deutocerebral lobes. These swellings are the tritocerebral lobes and the segment in which they lie is known accordingly as the tritocerebral segment.

The fourth, fifth, and sixth pairs of ganglia belong to the gnathocephalon which includes the mandibular, the maxillary, and the labial segments (pl. 3, fig. 33). They are all typical ventral chain ganglia in their origin, each pair being united by two prominent commissures in the early stages. Although arising separately, these three pairs of ganglia ultimately fuse to form the single suboesophageal ganglion of the late embryo and larva (pl. 3, fig. 26; pl. 12, figs. 86, 87, 88).

The seventh, eighth, and ninth pairs of ganglia are developed in the three thoracic segments. Unlike the coalesced neuromeres of the gnathocephalon, these preserve their identity and are distinct in the larva (pl. 12, fig. 87).

The 10 posterior pairs of ganglia belong to the abdominal region, one pair originating in each segment thereof except the most caudal one. During development there is a shortening of the ventral cord and a resultant anterior movement of these ganglia so that they do not all remain in the segments of their origin. The definitive number of abdominal ganglia present in the late embryo is eight. The first of these remains in the first segment, but moves to its anterior region. The second finally extends somewhat over into the first segment. The third ganglion has its final position partly in the second somite and partly in the third. The fourth ganglion takes up a similar position between the third and fourth segments. The fifth ganglion entirely leaves the segment of its origin and in the late embryo lies in the posterior region of the fourth segment. In a similar manner the sixth ganglion of the abdomen migrates into the posterior part of the fifth segment. The seventh ganglion is even less conservative, as it moves into the middle portion of the sixth segment. The eighth definitive ganglion of the abdomen is somewhat longer than the others of this region and is really a composite structure formed by the coa-

lescence of the last three ganglionic pairs, viz, those originating in the eighth, ninth, and tenth segments respectively. This eighth definitive ganglion of the late embryo lies in the anterior part of the seventh somite.

#### COELOMIC SACS

The segmental arrangement of the coelomic sacs characteristic of annelids and arthropods is manifested in the development of flea embryos (pl. 10, fig. 77). The lateral migration of the immigrated cells of the lower layer will be recalled from the account given in a previous section. By this migration a complete layer of mesoderm is formed below the ectoderm. This extends the full width of the germ band. Soon the extreme lateral margins of this lower layer become thickened to form the mesodermal bands. The mesoderm, like the superficial layer, is divided into metameres by the segmentation process. In most of the mesodermal somites formed by this process, there is developed a pair of coelomic sacs (pl. 2, fig. 21; pl. 10, fig. 76). These arise as small cavities within the intrasegmental regions of the mesodermal bands. In flea embryos the lumina of these cavities are bounded by thick walls and are similar to those described by Heider (1889) for *Hydrophilus*. There is no communication between the sacs of adjacent segments to form mesodermal tubes such as Nelson (1915) found in the embryos of *Apis*. In regard to the nature of these rudimentary coelomic primordia in fleas it may be stated that it is intermediate between the condition manifested in *Apis* and that which occurs in many Diptera. In the embryonic development of the Muscidae there is no indication of coelomic sacs according to Graber (1889). Similarly, Gambrell (1933) and Butt (1934) found no coelomic cavities in the embryos of *Simulium* and *Sciara* respectively. Moreover, owing to the small size and the thick walls of the coelomic sacs occurring in fleas, these structures in the embryos of the Siphonaptera are very different from their homologs in such primitive insects as *Lepisma* and the Orthoptera. In all of these forms, Heymons (1895, 1897) discovered that the primitive mesodermal cavities are very extensive and possess thin walls, approximating the type found in such lower arthropods as *Peripatus*. As in *Peripatus*, they extend into the appendage rudiments and ultimately the appendicular portion of each sac is constricted off, leaving the larger dorsal part to partake in the formation of the definitive body cavity.

Heider (1889) is of the opinion that in *Hydrophilus* the coelomic sacs represent the divided original lumen of the tube formed during



the differentiation of the lower layer. *Carrière* (1890) believes these cavities of the mesodermal somites originate in the same manner in the development of *Chalicodoma*. According to the supposition of these authors, the lumen of the original tube is incompletely and temporarily closed by a dorsoventral compression. This closure flattens the mesoderm into two distinct layers which are said to separate at a later time in the regions of their lateral margins to form the coelomic sacs. This explanation is in harmony with their designation of the mesodermal tube as an elongated gastrocoel. Apparently, it was an attempt to parallel the derivation of the coelomic pouches from the archenteron, such as occurs in certain other animals, and to harmonize the situation with the view of Hertwig and Hertwig (1881) which prompted their hypothesis. Graber (1890) was not able to substantiate Heider's statements as to the case of *Hydrophilus*, and the work of *Carrière* has not been confirmed. In the case of flea embryos there is no possibility of such an origin for the coelomic sacs even in the posterior region of the embryonic rudiment where a distinct mesodermal tube is formed, for the lower layer, when it reaches the lateral margins of the germ band, is only one cell thick. It is not until later that the paired mesodermal bands are produced, and their appearance is due to cellular proliferation of the originally single-layered mesoderm. In the Siphonaptera, therefore, the coelomic sacs arise as independent clefts in the thickened and solid lateral regions of the lower layer.

The number of the pairs of coelomic sacs occurring in the embryos of fleas appears to be 16. The most anterior of these lies in the deutocerebral segment. No indication of their presence was observed in either the preantennal or the intercalary segment. It appears that such cavities have been detected in the preantennal segment of only one insect form, viz, *Carausius morosus* (Wiesmann, 1926), and even in this generalized species they are rudimentary. As for paired mesodermal cavities occurring in the intercalary segment, they have been described in a few of the lower insects among which is *Carausius morosus* according to the work of Wiesmann cited above.

The 15 remaining pairs of coelomic sacs which occur in flea embryos are located in the first 15 segments posterior to the stomodaeal invagination. Three belong to the gnathocephalon, three to the thoracic region, and the remaining nine pairs are found in the first nine abdominal somites. The lumina of the most posterior pair are very small and rudimentary. The last two segments of the abdomen appear never to produce even such rudimentary cavities.

## THE BODY CAVITY

The definitive body cavity of fleas, as in other insects, is chiefly a secondary one in that it is derived for the most part from the epineural sinus, rather than from the lumina of the coelomic sacs. The epineural sinus, in turn, has its origin as a space resulting from the reduction in size of the deutoplasmic mass as the development of the embryo proceeds (pl. 2, fig. 21). As the vitelline mass shrinks, it withdraws from the germ band, first along the midventral region, so that the resulting cavity lies immediately above the nerve cord. In its origin, therefore, the cavity is specifically epineural. Later the epineural sinus is extended laterally and dorsally on both sides until finally, with the dorsal closure of the embryo, it entirely surrounds the mesenteron which has formed in the meantime about the remaining yolk. The cavities of the relatively small coelomic sacs are added to the epineural sinus. The splanchnic walls of these sacs break through (pl. 10, fig. 78), bringing their respective lumina into communication with the extensive epineural sinus, thereby establishing the definitive body cavity (pl. 2, fig. 24; pl. 11, fig. 79).

## MUSCLES

Even in the newly hatched larva the muscles are not sufficiently differentiated to facilitate identification. Therefore, no attempt was made to study their individual embryological origins. It may be said, however, that they have two general sources. The muscles of the body wall and those which are associated with the mouthparts and antennae are derived from the outer or somatic mesoderm. Some of the body wall muscles are longitudinal in arrangement, whereas others are oblique. In contrast to these somatic muscles, the muscles of the digestive tract are derived from the splanchnic mesoderm (pl. 11, fig. 80). These are either longitudinal or circular, and their arrangement appears to vary with the particular enteric region in question, as is known to be the case in adult insects.

## FAT CELLS

The fat cells of the flea embryo are not closely grouped to form compact masses such as form the fat bodies of the older larvae. Instead, they appear singly or as small irregular clumps of cells scattered throughout the definitive body cavity. Some of them lie dorsal to the dorsal diaphragm within the pericardial sinus and for this reason may be called pericardial fat cells. Others which lie ventral

to this diaphragm and within the perivisceral sinus, are the perivisceral fat cells. No fat cells were observed in the perineural sinus.

The embryonic fat cells of fleas are very similar to the adipose cells of the higher animals. They appear to become distended with oil at a very early age. As in the adipose cells of mammals, the nucleus is displaced to the surface where it appears like the set in a ring. This condition differs from the observations of Nelson (1915) on the newly hatched larva of the honeybee in which form the fat cells only occasionally were found to possess a minute fat globule.

The embryonic origin of the irregularly placed fat cells in the flea embryo is difficult to follow in detail. They are definitely mesodermal derivatives, however. From their positions, it appears that the pericardial fat cells come from the somatic layer, whereas the perivisceral ones are derived from the splanchnic mesoderm adjacent to the developing enteric muscles.

#### CIRCULATORY SYSTEM

The circulatory system of the flea larva is composed of the dorsal blood vessel (heart) and the various sinuses of the haemocoel. The dorsal blood vessel is one of the last structures to be formed. It is derived, as in other insect embryos, from cells which are known as cardioblasts. At the time of their first appearance, they constitute a pair of narrow longitudinal bands, one band located dorsolaterally on each side of the body along the line of junction between the somatic and splanchnic portions of the mesoderm. With the dorsal growth of the mesoderm and the corresponding extension of the body cavity as the vitelline mass shrinks away from the upper surface of the egg, the cardioblastic bands gradually approach one another and ultimately meet along the dorsal midline. The apposition of the splanchnic mesoderm to the surface of the already completed mid-intestine epithelium is simultaneous with this process. Some time before the two heart-forming bands of cells unite, these become separated from the enteric muscle-producing portion of the mesoderm. The cardioblasts never lose their connection with the somatic mesoderm, however. The actual union of the two cardioblastic bands, to form the dorsal blood vessel, occurs shortly afterward. This tube extends well into the head region.

The open portion of the circulatory system in the flea larva is similar to that of other forms. It consists of the definitive haemocoel which is formed from the completed and partially partitioned epineural sinus plus the coelomic sacs. This partitioning takes place by

the formation of two indistinct horizontal septa. The dorsal diaphragm is produced by the somatic mesoderm which, as stated above, remains attached to the cardioblastic strands. The ventral diaphragm, which is even less distinct than its dorsal counterpart, appears to be developed from the ventral somatic mesoderm.

Like the other structures of the circulatory system, the haematocytes of flea embryos appear to be mesodermal in origin. They are all nucleated cells. Wigglesworth (1934) is of the opinion that haematocytes may play a part in the organogenesis of insects by producing connective tissue membranes to cover the internal organs. In the case of flea development the enclosing membranes, of the gonads at least, are not formed in this manner.

The embryonic blood cells in fleas seem to take their origin by proliferation from the intermediate mesoderm between the longitudinal mesodermal bands. Snodgrass (1935) suggests, however, that because of their later phagocytic and digestive activities, it is possible that the haematocytes of insects are really derived from the intermediate strand of entoderm which is differentiated in some insects such as the Isoptera (Strindberg, 1913). If this supposition is correct, they are to be regarded as genetically related to the secondary trophonuclei and the epithelial cells of the mesenteron.

#### GONADS

The origin of the germ cells and their migration to the epineural sinus has been described in a previous section. Having arrived in the region of the fifth abdominal segment, the germ cells, now gonidia, become apposed to the inner surface of the splanchnic mesoderm to form two groups of cells, one on each side of the body. With the rupture of the coelomic sacs and the inward movement of the splanchnic mesoderm toward the mesenteron the germ cells are carried along farther toward the interior. Then again, with the dorsal migration of the cardioblasts and until the separation of the splanchnic mesoderm from the cardioblastic bands, the clumps of germ cells are moved somewhat dorsally. During these changes in position the sex cells on each side become enclosed by a covering of the splanchnic mesodermal cells with which they are associated (pl. 12, fig. 89). These covering cells gradually become flattened to form the follicular epithelium of the gonad. Posteriorly, splanchnic mesodermal cells, similar to those which form the epithelial envelope, differentiate into a strand which is continuous with the gonad (pl. 12, fig. 90). This tube is the anlage of the oviduct or vas deferens depending upon the sex of the larva.

There is some variation as to the definitive position of the gonads in the flea larva. During development, the body of the sex organ is observed to lie in parts of three different segments. These are the fourth, fifth, and sixth abdominal segments. The definitive larval gonads lie in one of these somites. Lass (1905) says that the larval ovaries are located in the sixth abdominal segment whereas the testes are situated further anterior. If his differentiation is correct, it may be assumed that the gonad anlagen of the female contract to form the larval ovaries which are restricted to the sixth abdominal segment. Likewise, the anlagen of the testes contract to occupy positions anterior to their female counterparts. These are in the region of the fourth abdominal segment.

#### TRACHEAL SYSTEM

The tracheae of fleas, like those of other insects, arise as paired invaginations of the ectoderm. These are segmental in arrangement. They first become evident about the time the coelomic sacs make their appearance and while the neural groove is still open (pl. 2, fig. 28). They are situated near the lateral margins of the germ band. The mouths of the invaginations ultimately become the spiracles, while the invaginations themselves deepen, branch, and anastomose to form the complex respiratory system of the larva. A longitudinal section along one of the tracheae is shown in figure 30 (pl. 2). The definitive number of spiracles found in the fully developed flea embryo is 10 pairs. These are located on the prothorax, the metathorax, and the first eight abdominal segments. All of them arise in their definitive position except the first, which originates on the mesothorax and migrates to its larval position during embryonic development. Its position near the posterior margin of the prothoracic segment is indicative of its mesothoracic origin. Evanescent tracheal invaginations, such as have been observed in *Leptinotarsa* (Wheeler, 1889) and *Calendra* (Wray, 1937), originating in the prothoracic segment, were not found in the flea embryo. Likewise, no transitory tracheal pits corresponding to those described by Nelson (1915) as occurring on the labial segment of the embryo of *Apis* were discovered in this study. Tracheal invaginations of a rudimentary nature, arising on abdominal segments posterior to the eighth like those reported in *Lepisma* (Heymons, 1897), *Leptinotarsa* (Wheeler, 1889), and *Calendra* (Wray, 1937), also appear to be lacking in the development of fleas.

## OENOCYTES

These cells, whose function is as yet not definitely known, have been observed in a number of insect forms. In flea embryos they are enormous in size in comparison to the other cells about them (pl. 2, fig. 30). Their nuclei are large, regular, and oval. The origin of the oenocytes has been traced in *Melolontha*, *Lina*, and *Hydrophilus* by Graber (1891). He found that in the embryos of these beetles the oenocytes arise from paired metastigmatic invaginations of the ectoderm. Wheeler (1892) found similar invaginations in *Blatta* and *Xiphidium*, but is of the opinion that they are of minor importance in the differentiation of these cells. He also studied the origin of the oenocytes in a wide variety of embryos including representatives of the Hemiptera, the Ephemera, the Neuroptera, and the Lepidoptera. In these forms, metastigmatic invaginations were not found and the oenocytes were observed to arise by simple delamination from the lateral ectoderm. During the present study oenocytes were seen in several stages of development in the flea embryo. As in *Blatta* and *Xiphidium*, the oenocytes arise in fleas from the lateral ectoderm of the anterior region of the abdomen, and metastigmatic invaginations are differentiated. When first proliferated, the oenocytes are similar in size and appearance to the other ectodermal cells. They grow rapidly, however, and soon become readily distinguishable. They were observed only in the abdominal region where they are frequently associated with the cells of the fat body within the body cavity. They often lie adjacent to tracheal invaginations.

## OTHER ECTODERMAL DERIVATIVES

In addition to the ectodermal derivatives which have been discussed already, the ectoderm gives rise to a number of other structures which have not been considered in detail during this study. These include the epidermis (hypodermis), the tentorium and apodemes of the endoskeleton, the corpora allata, the labial (salivary) glands, the silk glands, and the anlagen of the posterior portions of the genital tract. The ectodermal origin of these structures in fleas is in agreement with the work done on other insects.

In regard to the epidermis it may be added that this layer of the body wall is derived from what remains of the ectoderm in its superficial embryonic position after all the invaginations and delaminations to form the internal ectodermal organs have occurred. Furthermore, in flea development, no extra-embryonic dorsal sheet of ectoderm, such as Nelson (1915) describes for *Apis*, is differentiated. The

cuticula makes its appearance during the sixth or final day of development. This forms a sclerotized covering, the exoskeleton of the larva. It is secreted by the cells of the epidermis, and, as it is impermeable, its presence becomes manifest in attempts to stain late embryos for whole mounts. Unhatched larvae, after being kept in alcoholic borax carmine for several days, remained absolutely unstained except for a light coloration of the ectodermal regions of the digestive tract. This coloration was apparently due to seepage of the stain through the mouth and anal openings.

The setae also appear during the final day of embryonic development. As in other insects, they are produced as elongated hardened processes of certain of the epidermal cells.

The hatching spine of the flea embryo likewise makes its appearance during the final day of development. It, too, is a secondary epidermal structure and occurs as a sharp ridge located on the middorsal line of the head (pl. 3, fig. 31).

#### HATCHING

Unlike certain other insects such as *Leptinotarsa* (Wheeler, 1889), *Lina* (Graber, 1877), the Neuroptera (Smith, 1922), and *Tenebrio* (Sikes and Wigglesworth, 1931), the flea larva is not invested in a cuticular envelope at the time of hatching.

The normal hatching process of fleas has been described by Sikes and Wigglesworth (1931) and agrees in most points with the observations made during this study. Late in the last or sixth day of its life within the egg shell, the now fully differentiated larva expands to fill completely the lumen of the egg. This increase in size is due to a distention of the larva brought about by its swallowing the amniotic fluid. Since the withdrawal of the serosa and amnion into the vitellus prior to the dorsal closure, the amniotic fluid has filled the space between the vitelline membrane and the embryo. The ingestion of this fluid may be observed clearly through the relatively transparent chorion of *Ctenocephalides felis*. When the larva swallows the amniotic fluid its spiracles become exposed to the air, and following this exposure the liquid contents of the tracheal system is absorbed and air takes its place. After a time the larva begins to move about within the egg, and it is at this point that the hatching spine which has been described above comes into use. The spine acts as a can-opener and in due time normally pierces both the vitelline and chorionic membranes. As it moves about inside the shell, the larva ordinarily travels in a longitudinal direction. Almost always, therefore, the slit made

by the hatching spine is longitudinal. If the larva happens to cut such a slit along one entire side of the egg between the curvatures of the poles, it is able to crawl out. If, however, the hatching spine slips out of the cut and the slit in the chorion is too small to allow an escape, muscular contractions of the larva's body may be used to tear the shell open far enough to allow an escape. The hatching spine of fleas is definitely a part of the first instar larval cuticula and is retained, consequently, until the first ecdysis.

#### SUMMARY

*Ctenocephalides felis* (Bouché), *Nosopsyllus fasciatus* (Bosc.), and *Hystrihopsylla dippici* Roths. are the species studied. Except for variations in the external characteristics of the eggs, no specific differences were observed.

Satisfactory sections of the eggs at all stages of development were obtained by the use of a double imbedding combination technique involving modifications of Boycott's clove oil celloidin and Wall's hot celloidin methods. Tertiary butyl alcohol was used for all dehydration series.

The eggs are centrolecithal. The periplasm of the egg is reached by spermatozoa by means of micropylar openings which are arranged in circular areas, one at each pole.

Maturation of the female pronucleus occurs in the anterior periplasm. Syngamy occurs in the central region of the egg, as a rule somewhat toward the anterior pole. The periplasm is very thin except at the posterior pole where it is widened to form the posterior polar-plasmic cap. An inner protoplasmic reticulum is continuous with the periplasmic layer and ramifies throughout the vitellus.

Cleavage is meroblastic peripheral. The periplasm is first supplied with nuclei following the seventh cleavage division. The nuclei usually reach the periplasm at all points simultaneously. Four blastema substages are recognized. Blastulation consists of the delimitation of the nucleated periplasm of the last blastema substage into cell territories. Three blastula substages are evident. The second blastula substage is produced by a concentration of cells toward the ventral surface. The third blastula substage follows the eleventh mitotic division which involves only the cells of the thickened blastoderm, thus producing the anlage of the ventral plate. Cell accumulations produced by emigration from the blastoderm appear near the anterior and posterior extremities of the ventral plate. These are the mesenteron rudiments.



The trophonuclei have two origins. The primary trophonuclei are formed from cleavage nuclei which remain within the vitellus when the first blastema stage is produced. The secondary trophonuclei are derived from cells which return into the vitellus from the blastoderm or mesoderm of the germ band. Secondary yolk cleavage does not occur.

Posterior polar granules are not evident. The germ cells are polynuclear in origin. Their number varies from 5 to 12 in different eggs. The first protoplasmic pockets appear at the posterior pole during the first blastema substage. The germ cells produced thereby complete their constriction during the second blastema substage. More lateral ones may be somewhat delayed. The germ cells reenter the egg before blastulation.

The mesoderm originates by three methods. In the anterior third of the germ band this is by simple emigration of cells from the blastoderm. In the middle region a shallow median longitudinal groove assists in the process. Along the sharp bend of the germ band, where the embryonic rudiment is involuted into the vitellus, the groove is transformed into an invaginated mesodermal tube. In the short region between the section of tube formation and the posterior mesenteron rudiment, a simple groove is again produced. Along the short length of the germ band which is carried around the terminus of the invaginating proctodaeum, the mesoderm is again formed by simple emigration.

The germ band is partially superficial and partially involuted at the time of mesodermal differentiation. The amnion and serosa are formed by the overgrowth and fusion of the amnio-serosal folds, aided in the posterior region by the involution process. Both embryonic membranes disappear before eclosion, the serosa first and the amnion later, each rupturing and forming a dorsal organ. The dorsal organs are absorbed by the vitellus.

The growth and movements of the germ band or embryo are as follows. The formation of the ventral plate occurs on the first day of development. Involution of the posterior portion of the embryonic rudiment takes place on the second day. Withdrawal of the involuted section of the germ band follows during the first part of the third day. The anterior and posterior extremities lie close together on the dorsal surface at this stage. On the fourth day the embryo shortens toward the poles of the egg. On the fifth day it flexes ventrally and begins to lengthen. This elongation is continued during the sixth or final day of development so that the extremities coil upon themselves, one on either side of the middle portion of the body.

Segmentation becomes externally evident during the latter part of the third day of development. The early distinguishable procephalic lobes form three segments: the labral, the antennal, and the intercalary. The protocormic region gives rise to 17 segments. The first three are the gnathal segments and the next three are those belonging to the thorax. The remaining 11 form the abdomen.

The digestive tract arises partly from anterior and posterior invaginations of the ectoderm. These are the stomodaeum and proctodaeum respectively. They grow toward each other pushing the mesenteron rudiments before them. The proctodaeum arises in conjunction with the amniotic cavity. The stomodaeal invagination produces the fore-intestine and the proctodaeal invagination gives rise to the hind-intestine. The anterior and posterior mesenteron rudiments each proliferate to form two lateroventral ribbons. The mesenteron ribbons of each end grow toward and ultimately fuse with those of the opposite end. They also widen until they completely enclose the remaining yolk mass, thus forming the epithelium of the midintestine. The ventral completion of this lining is accomplished first, dorsal closure being delayed until after the absorption of both dorsal organs. The four malpighian tubules develop as diverticula of the proctodaeum. They are evident by the end of the third day of development.

The central nervous system arises from two lateral cords, one below each neural ridge, and from a middle cord which is located below the neural groove. Two pairs of ganglia, the protocerebral and deutocerebral, form anterior to the stomodaeum. A third pair, the tritocerebral, originating posterior to this invagination, moves forward and fuses with the first two pairs to form the definitive brain or supraoesophageal ganglion. The three pairs of ganglia which originate in the gnathal segments coalesce to produce the suboesophageal ganglion. The three thoracic ganglia remain distinct. Of the 10 abdominal ganglia, the last 3 fuse to form one definitive ganglion. The nerve cord shortens in the late embryo so that not all of the abdominal ganglia lie in the segments of their origin.

Sixteen pairs of coelomic sacs are formed. They arise in the intra-segmental portions of the mesodermal bands, one pair in the deutocerebral segment and in each of the first 15 segments posterior to the stomodaeal invagination. These sacs are thick-walled and possess small lumina. They soon break open and join their cavities to the epineural sinus to form the definitive body cavity or haemocoel.

The gonads are prominent embryonic organs. They are produced by the formation of a splanchnic mesodermal sheath about the gonial

cells which have separated into two groups and migrated laterally and anteriorly during the development of the embryo. The gonads lie in abdominal segments four to six. A mesodermal strand, the genital duct anlage, passes posteriorly from the body of the gonad.

Other mesodermal derivatives are the muscles, fat cells, haematocytes, and the limiting walls of the circulatory system. From the ectoderm are derived such additional structures as the tracheae and tracheoles, the oenocytes, the endoskeleton, the labial and silk glands, the corpora allata, parts of the genital tract, and the epidermis together with its secondary structures such as the cuticle, the setae, and the hatching spine.

Hatching occurs after 6 days of development under the temperature and relative humidity standards followed in this study. After swallowing the amniotic fluid, the young larva escapes from the egg through a slit in the shell made either by the hatching spine alone or by this spine aided by muscular contractions of the body.

#### LITERATURE CITED

AUTEN, MARY

1934. The early embryological development of *Phormia regina*: Diptera (Calliphoridae). *Ann. Ent. Soc. Amer.*, vol. 27, pp. 481-499.

AYERS, H.

1884. On the development of *Oecanthus niveus* and its parasite *Telcas*. *Mem. Boston Soc. Nat. Hist.*, vol. 3, pp. 225-281.

BAKER, C. F.

1905. The classification of the American Siphonaptera. *Proc. U. S. Nat. Mus.*, vol. 29, pp. 121-170.

BALBIANI, E. G.

1875. Sur l'embryogénie de la puce. *C. R. Acad. Sci. Paris*, vol. 81, pp. 901-906.

1882. Sur la signification des cellules polaires des insectes. *C. R. Acad. Sci. Paris*, vol. 95, pp. 927-929.

BLOCHMANN, F.

1884. Ueber eine Metamorphose der Kerne in den Ovarialeiern und über den Beginn der Blastodermbildung bei den Ameisen. *Verhandl. Naturhist.-Med. Ver. Heidelberg*, pp. 243-247.

1886. Ueber die Reifung der Eier bei Ameisen und Wespen. *Festschrift zur Feier des Fünfhundertjährigen Bestehens der Ruperto-Carola*, dargebracht von dem Naturhist.-Med. Ver. Heidelberg, pp. 143-172.

- 1887a. Ueber das regelmässige Vorkommen von bacterienähnlichen Gebilden in den Geweben und den Eiern verschiedener Insecten. *Zeitschr. Biol.*, vol. 24, pp. 1-15.

- 1887b. Ueber die Richtungskörper bei Insekteneiern. *Biol. Centbl.*, vol. 7, pp. 108-111.

BOBRETZKY, N.

1878. Ueber die Bildung der Blastoderms und der Keimblätter bei den Insecten. *Zeitschr. Wiss. Zool.*, vol. 31, pp. 195-215.

BRANDT, A.

1869. Beiträge zur Entwicklungsgeschichte der Libelluliden und Hemipteren, mit besonderer Berücksichtigung der Emybrionalhülle derselben. Mém. Acad. Imp. St. Petersburg, ser. 7, vol. 13, pp. 1-33.

BÜTSCHLI, O.

1888. Bemerkungen über die Entwicklungsgeschichte von *Musca*. Morph. Jahrb., vol. 14, pp. 170-174.

BUTT, F. H.

1934. Embryology of *Sciara* (Sciaridae: Diptera). Ann. Ent. Soc. Amer., vol. 27, pp. 565-579.
1936. The early embryological development of the parthenogenetic alfalfa snout beetle, *Brachyrhinus ligustici* L. Ann. Ent. Soc. Amer., vol. 29, pp. 1-14.

CARRIÈRE, J.

1890. Die Entwicklung der Mauerbiene (*Chalicodoma muraria* Fabr.) im Ei. Arch. Mikros. Anat., vol. 35, pp. 141-165.

CARRIÈRE, J., und BÜRGER, O.

1897. Die Entwicklungsgeschichte der Mauerbiene (*Chalicodoma muraria* Fabr.) im Ei. Nova Acta Abhandl. K. Leopold-Carolin. Deutsch. Akad. Naturf., vol. 69, pp. 253-420.

CLAYPOLE, A. M.

1898. The embryology and oögenesis of *Anurida maritima* (Guer.). Journ. Morph., vol. 14, pp. 219-300.

DU BOIS, A. M.

1932. A contribution to the embryology of *Sciara* (Diptera). Journ. Morph., vol. 54, pp. 161-195.

EASTHAM, L. E. S.

1927. A contribution to the embryology of *Pieris rapae*. Quart. Journ. Micr. Sci., vol. 71, pp. 353-394.
1930. The embryology of *Pieris rapae*—organogeny. Phil. Trans. Roy. Soc. London, Ser. B, vol. 219, pp. 1-50.

EWING, H. E.

1929. A manual of external parasites. Pp. 1-225. Springfield, Ill.

FRIEDERICHS, K.

1906. Untersuchungen über die Entstehung der Keimblätter und Bildung des Mitteldarms bei Käfern. Nova Acta. Abhandl. K. Leopold-Carolin. Deutsch. Akad. Naturf., vol. 85, pp. 265-382.

GALIGHER, A. E.

1934. The essentials of practical microtechnique in animal biology. Pp. 1-288. Berkeley, Calif.

GAMBRELL, MRS. F. L. (Lydia A. Jahn)

1933. The embryology of the black fly *Simulium pictipes* Hagen. Ann. Ent. Soc. Amer., vol. 26, pp. 641-672.

GANIN, M.

1869. Ueber die Embryonalhülle der Hymenopteren- und Lepidopteren-embryonen. Mém. Acad. Imp. Sci. St. Petersburg, ser. 7, vol. 14, p. 5.

GATENBY, J. B.

1918. The segregation of the germ cells in *Trichogramma evanescens*. Quart. Journ. Micr. Sci., vol. 63, pp. 161-173.

## GRABER, V.

1871. Vergleichende Lebens- und Entwicklungsgeschichte der Insekten. Naturkräfte, vol. 22, München bei Oldenburg.
1877. Die Insekten. II Theil. München.
- 1888a. Ueber die primäre Segmentirung des Keimstreifs der Insekten. Morph. Jahr., vol. 14, pp. 345-368.
- 1888b. Vergleichende Studien über die Keimhüllen und die Rückenbildung der Insekten. Denkschr. Math.-Naturwiss. Kl. Kais. Akad. Wiss. Wien., vol. 55, pp. 109-162.
1889. Vergleichende Studien über die Embryologie der Insekten und insbesondere der Musciden. Denkschr. Math.-Naturwiss. Kl. Kais. Akad. Wiss. Wien., vol. 56, pp. 257-314.
1890. Vergleichende Studien am Keimstreif der Insekten. Denkschr. Math.-Naturwiss. Kl. Kais. Akad. Wiss. Wien., vol. 57, pp. 621-734.
1891. Beiträge zur vergleichenden Embryologie der Insekten. Denkschr. Math.-Naturwiss. Kl. Kais. Akad. Wiss. Wien., vol. 58, pp. 803-866.

## GRASSI, B.

1884. Studi sugli artropodi. Intorno allo sviluppo dell' Api nell' uovo. (Letta nella seduta ordinaria del 2 Marzo 1884). Atti dell' Acad. Gioenia Sci. Nat. Catania, ser. 3, vol. 18, pp. 154-222.

## HAGAN, H. R.

1931. The embryology of the polyctenid *Hesperoctenes fumarius* Westwood, with reference to viviparity in insects. Journ. Morph. and Physiol., vol. 51, pp. 1-92.

## HALLEZ, P.

1886. Sur la loi de l'orientation de l'embryon chez les insectes. C. R. Acad. Sci. Paris, vol. 103, pp. 606-608.

## HASPER, M.

1911. Zur Entwicklung der Geschlechtsorgane von *Chironomus*. Zool. Jahrb., vol. 31, pp. 543-612.

## HATSCHKE, B.

1877. Beiträge zur Entwicklungsgeschichte der Lepidopteren. Jen. Zeitschr. Naturw., vol. 11, pp. 115-145.

## HEGNER, R. W.

1908. The effects of removing the germ-cell determinants from the eggs of some chrysomelid beetles. Preliminary report. Biol. Bull., vol. 16, pp. 19-26.
- 1909a. The origin and early history of the germ cells in some chrysomelid beetles. Journ. Morph., vol. 20, pp. 231-296.
- 1909b. The effects of centrifugal force on the eggs of some chrysomelid beetles. Journ. Exp. Zool., vol. 6, pp. 507-552.
- 1911a. Experiments with chrysomelid beetles. III. The effects of killing parts of the eggs of *Leptinotarsa decemlineata*. Biol. Bull., vol. 20, pp. 237-251.
- 1911b. Germ cell determinants and their significance. Amer. Nat., vol. 45, pp. 385-397.
1912. The history of the germ cells in the paedogenetic larva of *Miastor*. Science, vol. 36, pp. 124-126.

- 1914a. Studies on germ cells. I. The history of the germ cells in insects with special reference to the Keimbahn-determinants. II. The origin and significance of the Keimbahn-determinants in animals. Journ. Morph., vol. 25, pp. 375-509.
- 1914b. Studies on germ cells. III. The origin of the Keimbahn-determinants in a parasitic hymenopteron, *Copidosoma*. Anat. Anz., vol. 46, pp. 51-69.
- 1914c. The germ-cell cycle in animals. Pp. 1-346. New York.
- 1914d. Experimental studies on the relation between the structure and development of the eggs of chrysomelid beetles. 16th. Rep. Michigan Acad. Sci., pp. 49-54.
1915. Studies on germ cells. IV. Journ. Morph., vol. 26, pp. 495-561.
1917. The genesis of the organization of the insect egg. Amer. Nat., vol. 51, pp. 641-661 and 705-717.
- HEIDER, K.
1885. Ueber die Anlage der Keimblätter von *Hydrophilus piccus* L. Abhandl. Kgl. Preuss. Acad. Wiss. Berlin, pp. 1-47.
1889. Die Entwicklung von *Hydrophilus piccus* L. Kgl. Acad. Wiss. Berlin, pp. 1-98. Jena.
- HERTWIG, O., and HERTWIG, R.
1881. Die Coelomtheorie. Versuch einer Erklärung des mittleren Keimblattes. Jena.
- HEYMONS, R.
1895. Die Embryonalentwicklung von Dermapteren und Orthopteren, unter besonderer Berücksichtigung der Keimblätterbildung. Monographisch bearbeitet. Pp. 1-136. Jena.
1897. Entwicklungsgeschliche Untersuchungen an *Lepisma saccharina* L. Zeitschr. Wiss. Zool., vol. 62, pp. 583-631.
- HUETTNER, A. F.
1923. The origin of the germ cells in *Drosophila melanogaster*. Journ. Morph., vol. 37, pp. 385-423.
- JOLIANSSEN, D. A.
1935. Dehydration and infiltration. Science, vol. 80, pp. 253-254.
- KAHLE, W.
1908. Die Paedogenese der Cecidomyiden. Zoologica, vol. 21, pp. 1-73.
- KOROTNEFF, A.
1885. Die Embryologie der *Gryllotalpa*. Zeitschr. Wiss. Zool., vol. 41, pp. 570-604.
- KORSCHULT, E., and HEIDER, K.
1899. Text-book of the embryology of invertebrates. (Translation of Lehrbuch der vergleichenden Entwicklungsgeschichte der wirbellosen Thiere). Vol. 3, pp. 260-410. New York.
- KOWALEVSKY, A.
1871. Embryologische Studien an Würmern und Arthropoden. Mém. Acad. Imp. Sci. St. Petersburg, vol. 16, pp. 11-70.
1886. Zur embryonalen Entwicklung der Musciden. Biol. Centbl., vol. 6, pp. 49-54.
- KULAGIN, N.
1897. Beiträge zur Kenntniss der Entwicklungsgeschichte von *Platygaster*. Zeitschr. Wiss. Zool., vol. 63, pp. 195-235.

LASS, M.

1905. Beiträge zur Kenntnis des histologisch-anatomischen Baues des weiblichen Hundflohes. Zeitschr. Wiss. Zool., vol. 79, pp. 73-131.

LASSMANN, G. W. P.

1936. The early embryological development of *Mclophagus ovinus* L., with special reference to the development of the germ cells. Ann. Ent. Soc. Amer., vol. 29, pp. 397-413.

LÉCAILLON, A.

1897. Note préliminaire relative aux feuillets germanitifs des Coléoptères. C. R. Soc. Biol., pp. 1014-1016.

1898. Recherches sur le développement embryonnaire de quelques chryso-mélides. Arch. Anat. Micros., vol. 2, pp. 118-176.

LEESON, H. S.

1932. Methods of rearing and maintaining large stocks of fleas and mosquitoes for experimental purposes. Bull. Ent. Res., vol. 33, pp. 25-31.

MARSHALL, W. S., and DERNEHL, P. H.

1905. Contributions toward the embryology of *Polistes pallipes* (Hymenoptera). I. The formation of the blastoderm and the first arrangement of its cells. Zeitschr. Wiss. Zool., vol. 80, pp. 122-154.

MERCIER, L.

1906. Les corps bactériodes de la blatte (*Pteriplancta orientalis*): *Bacillus Cucnoti* (n. sp. L. Mercier). (Note préliminaire.) C. R. Soc. Biol., vol. 61, pp. 682-684.

METCHNIKOFF, E.

1866. Embryologische Studien an Insekten. Zeitschr. Wiss. Zool., vol. 16, pp. 389-500.

NELSON, J. A.

1915. The embryology of the honey bee. Pp. 1-282. Princeton University Press.

NOACK, W.

1901. Beiträge zur Entwicklungsgeschichte der Musciden. Zeitschr. Wiss. Zool., vol. 70, pp. 1-56.

OUDEMANS, A. C.

1909. Neue Ansichten über die Morphologie des Flohkopfes, sowie über die Ontogenie, Phylogenie, und Systematik der Flöhe. Novit. Zool., vol. 15, pp. 133-158.

PACKARD, A. S.

1872. Embryological studies on hexapodous insects. II. *Pulex canis*. Peabody Acad. Sci., 3rd Mem.

1898. A text-book of entomology. Pp. 1-729. New York.

PATTEN, W.

1884. The development of Phryganids, with a preliminary note on the development of *Blatta germanica*. Quart. Journ. Micr. Sci., vol. 24, pp. 549-598.

PETRUNKEWITSCH, A.

1901. Die Richtungskörper und ihr Schicksal im befruchteten und unbefruchteten Bienenei. Zool. Jahrb. Abt. Anat. u. Ontog. der Thiere, vol. 14, pp. 573-608.

PHILIPTSCHENKO, J.

1912. Beiträge zur Kenntnis der Apterygoten. III. Die Embryonalentwicklung von *Isotoma cinerea*. Zeitschr. Wiss. Zool., vol. 103, pp. 519-660.

RITTER, R.

1890. Die Entwicklung der Geschlechtsorgane und des Darmes bei *Chironomus*. Zeitschr. Wiss. Zool., vol. 50, pp. 408-427.

ROBIN, C.

1862. Mémoire sur les globules polaires de l'ovule et sur le mode de leur production. C. R. Acad. Sci. Paris, vol. 54, pp. 112-116.

SCHAEFER, P. E.

1938. The embryology of the central nervous system of *Phormia regina* Meigen (Diptera: Calliphoridae). Ann. Ent. Soc. Amer., vol. 31, pp. 92-111.

SCHNETTER, M.

1934. Physiologische Untersuchungen über das Differenzierungszentrum in der Embryonalentwicklung der Honigbiene. Arch. Entw.-mech., vol. 131, pp. 285-323.

SIKES, E. K., and WIGGLESWORTH, V. B.

1931. The hatching of insects from the egg, and the appearance of air in the tracheal system. Quart. Journ. Micr. Sci., vol. 74, pp. 165-192.

SMITH, R. C.

1922. Hatching in three species of Neuroptera. Ann. Ent. Soc. Amer., vol. 15, pp. 169-176.

SNODGRASS, R. E.

1935. Principles of insect morphology. Pp. 1-667. New York.

STRINDBERG, H.

1913. Embryologische Studien an Insekten. Zeitschr. Wiss. Zool., vol. 106, pp. 1-227.

1917. Ueber die Embryonalentwicklung von *Pulex crinacci* (Bouché). Zool. Anz., vol. 48, pp. 258-263.

TIKHOMIROVA, OLGA

1890. Article on embryology of *Pulex serraticeps*. Obshchestvo ljubitelei estestvoznaniia, antropologii i etnografii. Izvestiia Moscow Universitet. 67, 3.

1892. Sur l'histoire du développement de *Chrysopa perla*. Congrès International de Zoologie, Deuxième Session, à Moscow, pp. 112-119.

UZEL, H.

1897. Vörläufige Mittheilung über die Entwicklung der Thysanuren. Zool. Anz., vol. 20, pp. 125-132.

1898. Studien über die Entwicklung der apterygoten Insekten. Pp. 1-58.

VOELTZKOW, A.

1889. Entwicklung im Ei von *Musca vomitoria*. Arb. Zool. Zoot. Inst. Wurzburg, vol. 9, pp. 1-48.

WALLS, G. L.

1932. The hot celloidin technic for animal tissues. Stain Tech., vol. 7, pp. 135-145.

WEBER, H.

1933. Lehrbuch der Entomologie. Pp. 1-726. Jena.

WEISMANN, A.

1863. Die Entwicklung der Dipteren im Ei, nach Beobachtungen an *Chironomus* spec., *Musca vomitoria* und *Pulex canis*. Zeitschr. Wiss. Zool., vol. 13, pp. 107-220.

1882. Beiträge zur Kenntnis der ersten Entwicklungsvorgänge im Insectenei. Beiträge Anat. u. Embryol. als Festgabe Jacob Henle.



WHEELER, W. M.

1889. The embryology of *Blatta germanica* and *Doryphora decemlineata*. Journ. Morph., vol. 3, pp. 291-372.

1892. Concerning the blood tissue of the insects. I-III. Psyche, vol. 6, pp. 216-220, 233-236, 253-258.

1893. A contribution to insect embryology. Journ. Morph., vol. 8, pp. 1-160.

WIESMANN, R.

1926. Zur Kenntnis der Anatomie und Entwicklungsgeschichte der Stabheuschrecke *Carausius morosus*. III. Entwicklung und Organogenese der Cölomläsen. Zool. Vergl. Anat. Inst. Univ. Zürich, pp. 1-205.

WIGGLESWORTH, V. B.

1934. Insect physiology. Pp. 1-134. London.

WILL, L.

1888. Entwicklungsgeschichte der viviparen Aphiden. Zool. Jahrb. Abth. Anat. Ontog. Thiere, vol. 3, pp. 201-286.

WRAY, D. L.

1937. The embryology of *Calceatra callosa* Olivier, the southern corn billbug (Coleoptera, Rhynchophoridae). Ann. Ent. Soc. Amer., vol. 30, pp. 361-409.

## EXPLANATION OF PLATES

### PLATE I

- FIG. 1. The micropylar apparatus at the posterior pole of an egg of *Nosopsyllus fasciatus* showing a tendency toward a spiral arrangement of the openings.  $\times 200$ .
- FIG. 2. Longitudinal section through a portion of the chorion at one end of an egg of *Hystrichopsylla dippiei* showing the volcanolike raised processes and the thick rigid shell of this species.  $\times 250$ .
- FIG. 3. Transverse section through a *Ctenocephalides felis* egg in the third blastema substage. Enlargements of this section are shown in figures 10 and 11.  $\times 100$ .
- FIG. 4. Margin of a section of a *Ctenocephalides felis* egg in the first blastema substage showing the vitelline spheres with their contained refringent vitelline bodies. Two nuclei may be seen in the periplasm.  $\times 450$ .
- FIG. 5. Margin of a section of a *Ctenocephalides felis* egg in the second blastema substage. This is an enlargement of a portion of the section shown in figure 40.  $\times 450$ .
- FIG. 6. Posterior margin of a section of a *Ctenocephalides felis* egg in the second blastula substage showing the transition from the thinned dorsal blastoderm to the thicker ventral blastoderm. A sagittal section through an entire egg at this stage is shown in figure 50.  $\times 450$ .
- FIG. 7. Longitudinal section through a *Ctenocephalides felis* egg in the first blastula substage.  $\times 100$ .
- FIG. 8. Anterior margin of a section of a *Ctenocephalides felis* egg in the fourth blastema substage showing the nuclei crowded together in the periplasm.  $\times 450$ .

- FIG. 9. Enlargement of a portion of the section shown in figure 7 demonstrating the division of the periplasm into cell territories.  $\times 450$ .
- FIG. 10. Enlargement of a portion of the section shown in figure 3. Four nuclei may be seen in the periplasm.  $\times 450$ .
- FIG. 11. Similar to figure 10.  $\times 450$ .
- FIG. 12. Longitudinal section through the anterior half of a *Ctenocephalides felis* egg in a stage just prior to syngamy showing one polar body (PB) lying in the periplasm and the sperm (SN) and egg (EN) nuclei among the vitelline spheres. Only one more nucleus, the other polar body, showed in sections made from this egg.  $\times 400$ .
- FIG. 13. Portion of a section through a *Nosopsyllus fasciatus* egg before cleavage showing the effect of Heidenhain's iron haematoxylin on the vitelline spheres. Some of the strands of the protoplasmic reticulum may be seen between these black spheres.  $\times 400$ .

## PLATE 2

- FIG. 14. Sagittal section through an egg of *Ctenocephalides felis* showing the early formations of the mesenteron rudiments. The flattening of the germ band at the posterior pole, the first step in the formation of the posterior mesenteron rudiment, is clearly demonstrated. The beginning of the anterior mesenteron rudiment may be seen as a slight thickening of the germ band just ventral to the anterior pole. An enlargement of the posterior portion of this section is shown in figure 51.  $\times 100$ .
- FIG. 15. Portion of the anterior margin of a *Ctenocephalides felis* egg showing the anterior mesenteron rudiment at a stage slightly later than that shown in figure 16. As yet there is no indication of the amnioserosal fold.  $\times 450$ .
- FIG. 16. Portion of the anterior margin of a *Ctenocephalides felis* egg showing the anterior mesenteron rudiment at the beginning of its formation. This stage corresponds to that shown in figure 14.  $\times 450$ .
- FIG. 17. Transverse section through the anterior third of the germ band of a *Ctenocephalides felis* egg at a stage somewhat later than that shown in figure 61, showing formation of the mesoderm by simple emigration of cells from the blastoderm. The embryonic membranes have completed their formation above the germ band at this stage.  $\times 400$ .
- FIG. 18. Horizontal section through a *Ctenocephalides felis* egg cutting the germ band through the procephalic lobes at the anterior end and through the region of mesodermal formation by the differentiation of a distinct tube at the posterior pole. The amniotic cavity is apparent above the tube.  $\times 100$ .
- FIG. 19. Enlargement of the posterior portion of the section shown in figure 18. This section is similar to that which is shown in figure 65.  $\times 400$ .
- FIG. 20. Horizontal section through a *Ctenocephalides felis* egg at a stage similar to that shown in figure 18 but at a somewhat more dorsal level. The procephalic lobes show to better advantage in this section. The plane of the cut follows the amnio-proctodaeal cavity for a short distance where the tail of the embryo turns into the vitellus at the posterior pole of the egg.  $\times 100$ .

- FIG. 21. Transverse section through the germ band of a *Nosopsyllus fasciatus* egg at the level of one of the pairs of coelomic sacs (CS). The epineural sinus is also shown, forming as a space between the embryonic band and the receding yolk mass.  $\times 400$ .
- FIG. 22. Transverse section through the procephalic lobes of a *Ctenocephalides felis* embryo showing details of the anterior region of the amniotic cavity together with the cellular nature of the amniotic and serosal membranes which cover it.  $\times 450$ .
- FIG. 23. Portion of a sagittal section through a *Ctenocephalides felis* egg with the anterior amnio-serosal fold beginning to form. The anterior mesenteron rudiment, at a stage a little later than that shown in figure 15, may be seen to the left of the fold.  $\times 400$ .
- FIG. 24. Transverse section through a *Ctenocephalides felis* embryo just prior to dorsal closure. The cells of the third dorsal organ may be seen sinking into the vitelline mass. At the left a portion of the definitive body cavity is evident. This section is at a stage similar to that shown in figure 79.  $\times 450$ .
- FIG. 25. Portion of a sagittal section through a *Ctenocephalides felis* egg at a stage a little later than that shown in figure 54. The amniotic membrane with its attenuated cells, the anterior mesenteron rudiment, the ectoderm, and the mesodermal layer are all clearly shown.  $\times 400$ .

## PLATE 3

- FIG. 26. Parasagittal section of a *Ctenocephalides felis* embryo during the fifth day of development showing the body curved ventrally. At this plane the supraoesophageal and suboesophageal ganglia are connected by one of the circumoesophageal connectives. The ganglionic thickenings of the ventral nerve cord are no longer evident on the surface.  $\times 100$ .
- FIG. 27. Horizontal section through a portion of the ventral nerve cord of a *Ctenocephalides felis* embryo showing the paired ganglia fused to form definitive ganglia. In two of these ganglia the two cross-commissural neuropile tracts are demonstrated. The interganglionic connectives are also shown.  $\times 450$ .
- FIG. 28. Portion of a transverse section through a *Nosopsyllus fasciatus* embryo showing a tracheal invagination in longitudinal section.  $\times 450$ .
- FIG. 29. Portion of a sagittal section through a *Ctenocephalides felis* embryo cutting the proctodaeum in longitudinal direction. This stage is a little later than that shown in figure 35.  $\times 450$ .
- FIG. 30. Section along a tracheal invagination of *Hystrichopsylla dippici* showing two large oenocytes lying adjacent to its wall. In this section a metastigmatic invagination parallels the tracheal invagination for a short distance.  $\times 300$ .
- FIG. 31. Transverse section showing a portion of the head of a late embryo of *Hystrichopsylla dippici*. The developing hatching spine is a prominent structure.  $\times 250$ .
- FIG. 32. Transverse section through the proctodaeum of a *Nosopsyllus fasciatus* embryo showing the four developing malpighian tubules.  $\times 400$ .

- FIG. 33. Sagittal section through the head of a *Ctenocephalides felis* embryo showing the blind end of the stomodaeum at this stage. Below the stomodaeum, the three fused ganglia of the gnathocephalon are demonstrated.  $\times 450$ .
- FIG. 34. Sagittal section through the stomodaeum of a *Ctenocephalides felis* embryo.  $\times 450$ .
- FIG. 35. Sagittal section through the proctodaeum of a *Ctenocephalides felis* embryo at a stage somewhat younger than that from which figure 29 was made.  $\times 450$ .
- FIG. 36. Portion of a section through a *Ctenocephalides felis* embryo at a stage somewhat older than that from which figure 35 was made. The proctodaeal invagination is considerably deeper in this stage.

## PLATE 4

- FIG. 37. Section through the middle anterior region of a *Ctenocephalides felis* egg showing the male and female gametic nuclei fusing in syngamy. Their peripheral processes are continuous with the reticular protoplasm which ramifies throughout the egg.  $\times 400$ .
- FIG. 38. Section through the middle anterior region of a *Ctenocephalides felis* egg at a stage immediately following syngamy. The star-shaped zygotic nucleus lies in the center of the field. The complete section from which this enlargement was made is shown in figure 39. The vitelline spheres and their enclosed vitelline bodies show very clearly.  $\times 400$ .
- FIG. 39. Longitudinal section through an unsegmented egg of *Ctenocephalides felis* showing the zygotic nucleus lying in the middle anterior region of the vitellus. This nucleus is shown enlarged in figure 38. The thin chorion of this species shows clearly in this section.  $\times 115$ .
- FIG. 40. Longitudinal section through a *Ctenocephalides felis* egg in the second blastema substage of development. As is usual in early-stage preparations, the nuclei are only faintly visible.  $\times 115$ .
- FIG. 41. Longitudinal section through a *Ctenocephalides felis* egg in the third blastema substage of development, showing the nuclei in the periplasm.  $\times 115$ .
- FIG. 42. Longitudinal section through the same egg as that from which figure 41 was made, showing three germ cells lying outside the egg at the posterior pole. These cells are shown enlarged in figure 46.  $\times 115$ .

## PLATE 5

- FIG. 43. Posterior portion of a longitudinal section through a *Ctenocephalides felis* egg prior to cleavage, showing the periplasm widened at the posterior pole to form a distinct cap, the posterior protoplasmic cap.  $\times 400$ .
- FIG. 44. Longitudinal section through the posterior region of a *Ctenocephalides felis* egg in the first blastema substage of development, showing four germ nuclei in the periplasm at the posterior pole.  $\times 400$ .

- FIG. 45. Longitudinal section through the posterior region of a *Ctenocephalides felis* egg at a stage immediately following that shown in figure 44, showing three germ cells bulging out preparatory to constriction. The granular appearance of the interior of the egg and of a part of the germ-cell cytoplasm is possibly due to Blochmann's corpuscles.  $\times 500$ .
- FIG. 46. Posterior portion of the section shown in figure 42, showing primordial germ cells which have been extruded from the egg mass at the posterior pole. They lie between the periplasm and the vitelline membrane.  $\times 400$ .
- FIG. 47. Longitudinal section through the posterior region of an egg of *Ctenocephalides felis*, also in the third blastema substage of development. Six germ cells are shown at the posterior pole, lying outside of the periplasm.  $\times 400$ .
- FIG. 48. Longitudinal section through the posterior region of a *Ctenocephalides felis* egg in the first blastula substage of development. The periplasm is distinctly divided into cell territories. This section also shows a small group of germ cells which have reentered the egg and are lying just within the blastoderm.  $\times 400$ .

## PLATE 6

- FIG. 49. Longitudinal section through a *Ctenocephalides felis* egg in the fourth blastema substage of development. The full quota of first blastula substage nuclei is present but the cell territories characteristic of the blastula stage have not been delimited.  $\times 115$ .
- FIG. 50. Sagittal section through a *Ctenocephalides felis* egg in the second blastula substage showing the crowding of the cells toward the ventral midline which is the first step in the formation of the ventral plate. The thinned dorsal region and the thickened ventral region are clearly distinguishable.  $\times 115$ .
- FIG. 51. Posterior portion of the section shown in figure 14, showing the flattening of the posterior pole of the germ band, the first step in the formation of the posterior mesenteron rudiment. A group of germ cells may be seen lying inside this flattened region.  $\times 400$ .
- FIG. 52. Transverse section through the germ band of *Ctenocephalides felis* showing the beginning of the formation of the paired lateral amnio-serosal folds.  $\times 400$ .
- FIG. 53. Sagittal section through the anterior region of a *Ctenocephalides felis* egg in a stage slightly more advanced than the one shown in figure 23. The anterior amnio-serosal fold and the anterior mesenteron rudiment are both very clearly shown as is also the shallow pit at the point of emigration of the mesenteron rudiment cells. The chorionic and vitelline membranes also show to advantage in this figure.  $\times 400$ .
- FIG. 54. Sagittal section through the anterior region of a *Ctenocephalides felis* egg at a stage somewhat more advanced than that shown in figure 53, showing the double nature of the amnio-serosal fold which has grown farther posteriorly. The ectoderm has entirely closed over the pit which existed above the mesenteron rudiment.  $\times 400$ .

## PLATE 7

- FIG. 55. Whole mount of a *Ctenocephalides felis* embryo dissected from the egg early in the third day of development. The germ band is unsegmented and the tail region is not entirely withdrawn from the vitellus. At this stage the embryo consists of two general regions, an anterior one widened to form the procephalic lobes and a posterior unwidened one forming the protocornic region.  $\times 115$ .
- FIG. 56. Sagittal section through a *Ctenocephalides felis* egg at a stage slightly younger than the one shown in figure 55 and corresponding to the stage shown in figure 54. The posterior amnio-serosal fold grows more rapidly than its anterior counterpart and may here be seen approaching the midventral region of the egg. This stage illustrates the maximum involution of the caudal region with the amnio-proctodaeal cavity lying at the center of the vitellus. It also shows how the germ band is carried around the inner extremity of this lumen.  $\times 115$ .
- FIG. 57. Horizontal section through a *Ctenocephalides felis* egg in the same stage of development as that shown in figure 55. The germ band is cut transversely in three places, at the anterior end through the procephalic lobes, at the middle of the egg through the tail where the embryonic rudiment rounds the amnio-proctodaeal cavity, and at the posterior end of the egg where the tail piece was originally invaginated into the vitellus. The amniotic and serosal membranes are complete and show at both poles of the egg.  $\times 115$ .
- FIG. 58. Section through a *Ctenocephalides felis* egg showing the involuted posterior portion of the germ band in transverse section at a plane posterior to the posterior mesenteron rudiment and at the center of the egg. The mesodermal cells may be seen migrating inward from the blastoderm. The lumen shown is the inner extremity of the amnio-proctodaeal cavity.  $\times 400$ .
- FIG. 59. Sagittal section through the posterior region of the germ band of *Ctenocephalides felis* at a stage similar to that shown in figures 56, 58, and 60. The posterior mesenteron rudiment cells are to be seen lying below the ectoderm adjacent to the posterior terminus of the amnio-proctodaeal cavity.  $\times 400$ .
- FIG. 60. Parasagittal section similar to the sagittal one shown in figure 59.  $\times 400$ .

## PLATE 8

- FIG. 61. Transverse section through the germ band of *Ctenocephalides felis* at a point between the anterior amnio-serosal fold and the anterior mesenteron rudiment showing mesoderm formation by simple emigration of cells from the blastoderm.  $\times 400$ .
- FIG. 62. Transverse section through the germ band of *Ctenocephalides felis* at a point in the anterior portion of its second third in that region of the embryonic rudiment where mesoderm formation is by the migration of cells from the blastoderm together with the formation of a groove.  $\times 400$ .

- FIG. 63. Transverse section through the middle portion of the germ band of *Ctenocephalides felis* where the method of mesoderm formation is similar to that described for figure 62.  $\times 400$ .
- FIG. 64. Transverse section through the germ band of *Ctenocephalides felis* at a point in the posterior extremity of the second-third region, showing mesoderm formation by cellular migration following shallow groove formation. The regular course of the mesodermal cells as they move laterally below the ectoderm is also shown. That this stage is somewhat later than that shown in figures 62 and 63 is indicated by the fact that the amnion is formed and that the ectoderm has closed over the point of emigration of the mesodermal cells, thereby practically eliminating the groove.  $\times 400$ .
- FIG. 65. Posterior portion of a horizontal section through a *Ctenocephalides felis* egg showing the germ band cut transversely at a point just anterior to the region of its involution into the vitellus. This figure illustrates mesodermal differentiation by the formation of a distinct tube and also shows the amniotic cavity in the region where it is about to be transformed into the amnio-proctodaeal cavity. The amnion and serosa are clearly indicated ventral to the amniotic cavity. This section corresponds to that shown in figure 19.  $\times 400$ .
- FIG. 66. Transverse section through the germ band of *Ctenocephalides felis* at a level slightly posterior to that shown in figure 65 and at a somewhat later stage. The mesodermal tube is compressed and its lumen is obscured. The amnio-proctodaeal cavity and the amnion are both clearly shown, and some of the attenuated cells of the serosa may be seen lying against the surface of the vitellus. A region of deutoplasm consequently separates the two embryonic membranes.  $\times 400$ .

## PLATE 9

- FIG. 67. Transverse section through the anterior region of the germ band of *Ctenocephalides felis* in that part which is differentiating into the procephalic lobes. The haphazard lateral progress of the mesodermal cells is shown. The amniotic cavity, amnion, and serosa may be seen above the germ band.  $\times 400$ .
- FIG. 68. Transverse section through the procephalic lobes of *Ctenocephalides felis* at a stage somewhat later than that shown in figure 67.  $\times 400$ .
- FIG. 69. Transverse section through the middle region of the germ band of *Ctenocephalides felis* showing the arrangement of the mesodermal cells at the completion of their migration from the blastoderm. The neural groove is beginning to form.  $\times 400$ .
- FIG. 70. Transverse section through a *Ctenocephalides felis* egg showing the germ band cut at two places. The completed amniotic and serosal membranes appear above the upper section. In both sections the neural groove and the layer of mesodermal cells lying below the ectoderm may be seen.  $\times 375$ .

- FIG. 71. Sagittal section through the posterior region of the germ band of a *Ctenocephalides felis* embryo showing the lumen of the proctodaeum together with two diverticula at its inner end representing the beginnings of two of the malpighian tubules.  $\times 400$ .
- FIG. 72. Transverse section through the germ band of a *Ctenocephalides felis* embryo showing the early differentiation of the ventral nerve cord. The neural groove is shown at the middle of the band and to the left of this groove, just below the ectoderm, several neuroblasts may be seen. These neuroblasts are larger and rounder than the mesoderm cells which lie below them. The elongated ectodermal cells are dermatoblasts.  $\times 400$ .

## PLATE 10

- FIG. 73. Whole mount of a *Ctenocephalides felis* embryo dissected from the egg after 3 days of development, when withdrawal of the tail from the deutoplasm is complete. Both the anterior and the posterior extremities of the germ band have grown around their respective poles of the egg and approximate each other on the dorsal surface. The segmentation is distinct.  $\times 115$ .
- FIG. 74. Parasagittal section of a *Ctenocephalides felis* embryo at a stage similar to that shown in figure 73. Segmentation is distinct. The oral appendages appear in order: labral, mandibular, maxillary, and labial. Because of the parasagittal plane of the section, the stomodaeum does not show, and on the maxilla is an apparent ventral projection. A deep cleft separates the maxilla from the labium. The three thoracic segments follow the labium and posterior to these come the abdominal segments. The eleventh abdominal segment has already been carried in from the surface by the invagination of the proctodaeum.  $\times 115$ .
- FIG. 75. Sagittal section through a *Ctenocephalides felis* embryo at a stage corresponding to that shown in figures 73 and 74. The stomodaeal and proctodaeal invaginations are clearly shown. The labrum lies anterior to the stomodaeum. Immediately posterior to this invagination the three gnathal segments appear very much fused.  $\times 115$ .
- FIG. 76. Transverse section through the germ band of a *Ctenocephalides felis* embryo showing the neural groove and coelomic sacs. The walls of the sacs are thick and their lumina very small. This stage corresponds to that shown in figure 77.  $\times 400$ .
- FIG. 77. Portion of a parasagittal section through the germ band of a *Ctenocephalides felis* embryo showing the segmental arrangement of the coelomic sacs.  $\times 400$ .
- FIG. 78. Transverse section through the germ band of a *Ctenocephalides felis* embryo showing how the neural groove is formed by the production of paired longitudinal thickenings, one such thickening on each side of it. The definitive body cavity or haemocoel, formed by the fusion of the epineural sinus and the ruptured coelomic sacs, is also shown.  $\times 400$ .



## PLATE 11

- FIG. 79. Dorsal portion of a transverse section through an embryo of *Ctenocephalides felis* at a stage just prior to dorsal closure showing the absorption of the third dorsal organ by the vitellus. At the left a layer of entodermal cells may be seen lining the yolk mass. To the left of these is a portion of the definitive body cavity. Parts of the chorionic and vitelline membranes are shown in the upper part of the figure. This stage is similar to that shown in figure 24.  $\times 400$ .
- FIG. 80. Sagittal section through a *Ctenocephalides felis* embryo at a stage somewhat more advanced than that shown in figure 75. The coiled hind-intestine of this stage is shown cut through in several places and the anterior mesenteron ribbons have formed a complete floor of entoderm for the yolk mass. This entodermal lining is covered by the splanchnic mesoderm and below this lies the haemocoel. A strip of somatic mesoderm appears in the midventral region of the embryo.  $\times 115$ .
- FIG. 81. Sagittal section through the anterior region of a *Ctenocephalides felis* embryo showing the inner end of the stomodaeum. The paired anterior mesenteron rudiments have fused ventrally and their cells are shown in this section lining the vitellus below the stomodaeum. The fusion of these ribbons dorsal to the stomodaeum is just beginning.  $\times 400$ .
- FIG. 82. Sagittal section through the anterior portion of a *Ctenocephalides felis* embryo showing the stomodacal invagination and the labrum.  $\times 400$ .
- FIG. 83. Horizontal section through the anterior region of a *Ctenocephalides felis* embryo showing the paired lateral mesenteron ribbons (MR) lying adjacent to the yolk.  $\times 400$ .
- FIG. 84. Portion of a section through a *Ctenocephalides felis* embryo showing the hind-intestine cut at two places. Three of the developing malpighian tubules may be seen communicating with the proctodaeum in the lower one of the cuts shown here.  $\times 400$ .

## PLATE 12

- FIG. 85. Portion of a sagittal section through a *Ctenocephalides felis* embryo showing several ganglia of the ventral nerve cord, each with its two transverse neuropile tracts.  $\times 400$ .
- FIG. 86. Transverse section through the head region of a *Ctenocephalides felis* embryo in a late stage of development. In the upper portion of this figure, and on either side of the oesophagus, are to be seen the paired posterior extremities of the supraoesophageal ganglion. The suboesophageal ganglion lies below the oesophagus and in this section is shown connected with the supraoesophageal ganglion by the neuropile tracts of the circumoesophageal connectives. This stage corresponds with that shown in figures 26 and 87.  $\times 400$ .
- FIG. 87. Sagittal section through a *Ctenocephalides felis* embryo in the fifth day of development shortly after ventral flexion. The proctodaeum is a particularly conspicuous structure. The supraoesophageal ganglion, the suboesophageal ganglion, and the chain of ventral

nerve ganglia also show to advantage. The ventral ganglionic thickenings are no longer evident on the surface. A parasagittal section of this same embryo is shown in figure 26.  $\times 115$ .

- FIG. 88. Parasagittal section through the head region of a *Ctenocephalides felis* embryo at a stage similar to that shown in figures 26 and 87 showing the supraesophageal and subesophageal ganglia connected by the circumoesophageal connective of the side. The lateral nature of the section is further indicated by the lack of transverse commissural tracts such as appear in the ganglia shown in figure 85. The definitive nature of the mandible is also evident in this figure.  $\times 400$ .
- FIG. 89. Portion of a sagittal section through a late embryo of *Ctenocephalides felis* showing the gonad cut longitudinally, revealing the prominent germ cells inside it.  $\times 400$ .
- FIG. 90. A similar section to that shown in figure 89 but showing the anlage of the genital duct leading posteriorly from the gonad.  $\times 400$ .

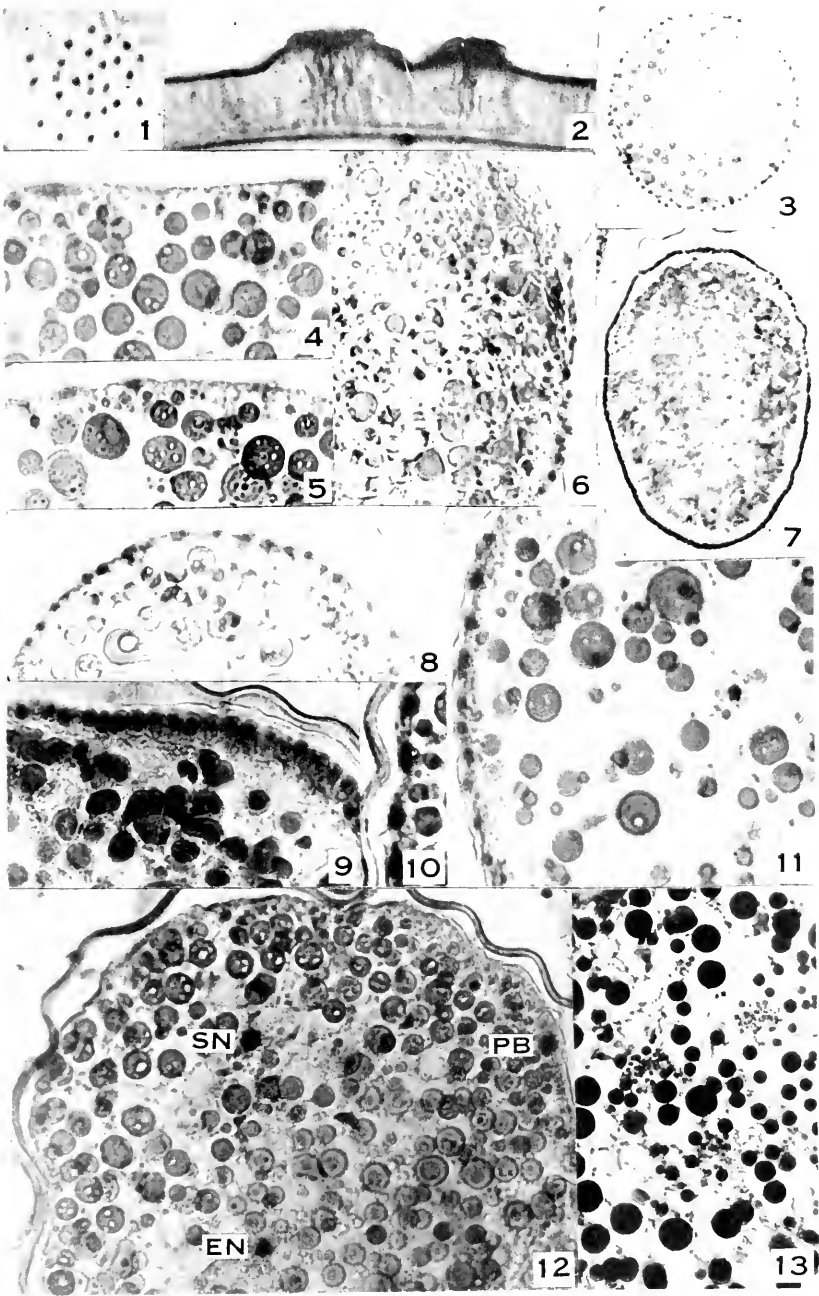

EMBRYOLOGY OF FLEAS  
 (See explanation of plates at end of text.)

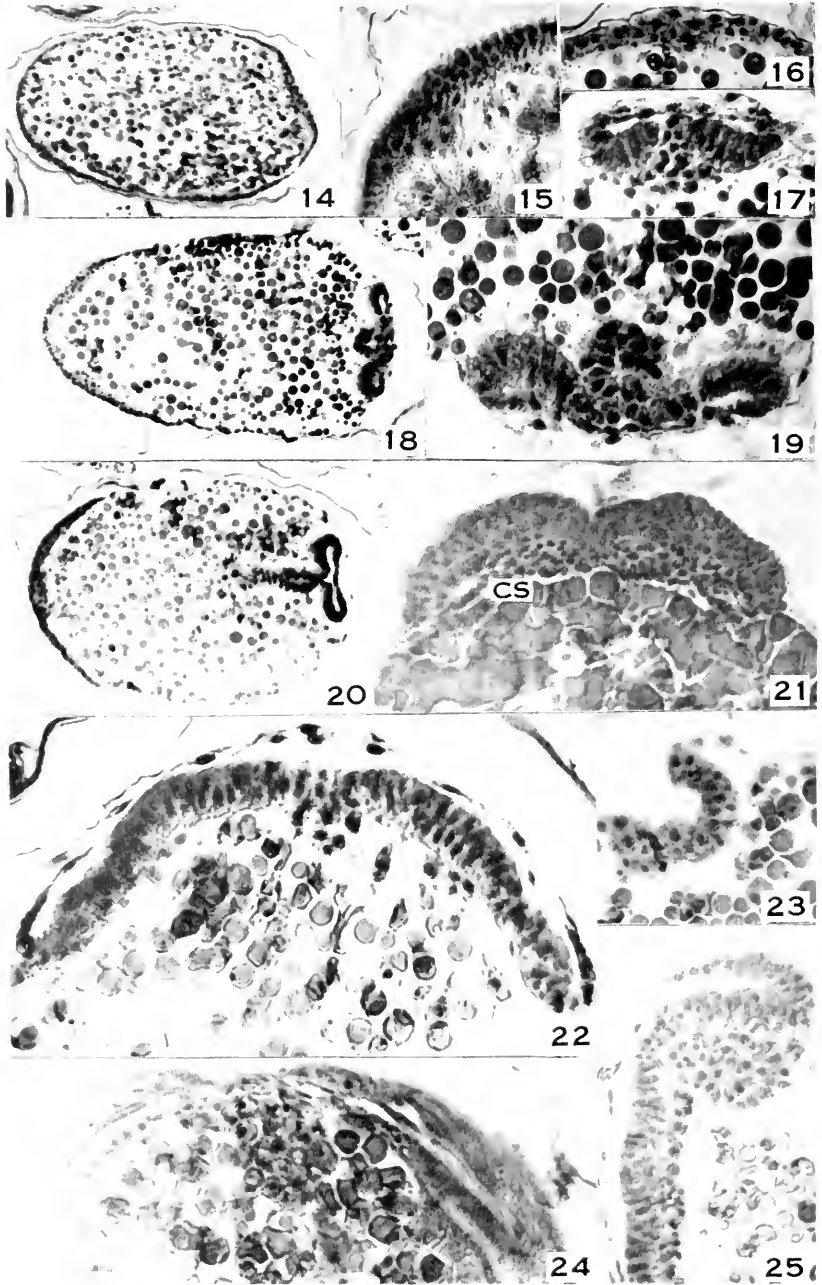

EMBRYOLOGY OF FLEAS  
(See explanation of plates at end of text.)

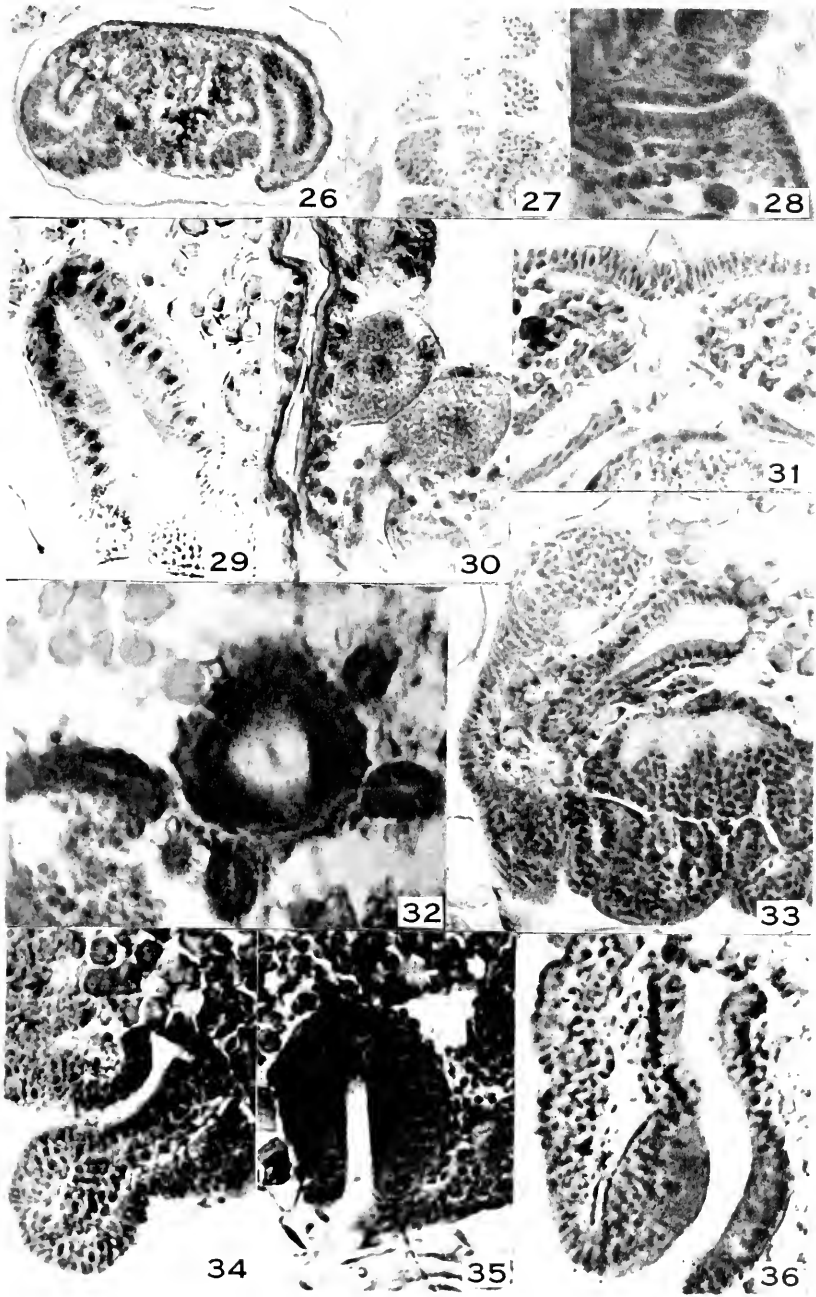

EMBRYOLOGY OF FLEAS  
(See explanation of plates at end of text.)

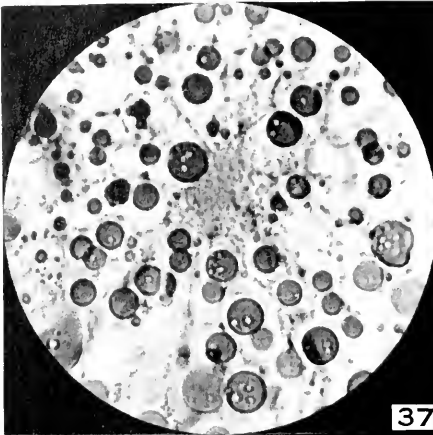

37

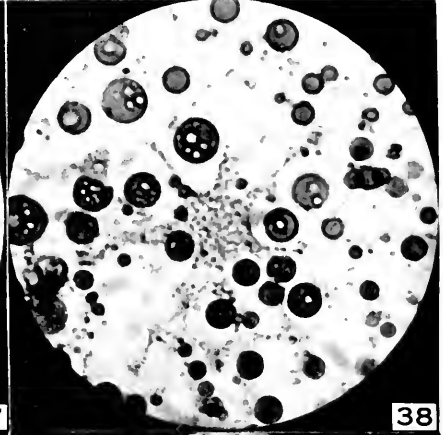

38

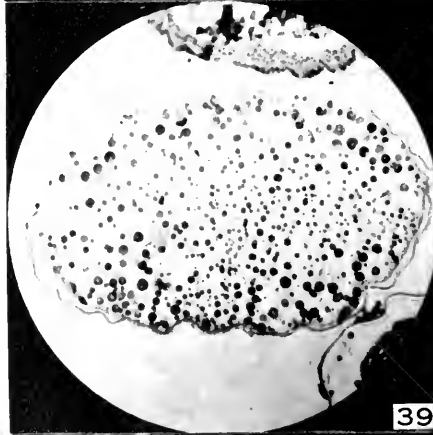

39

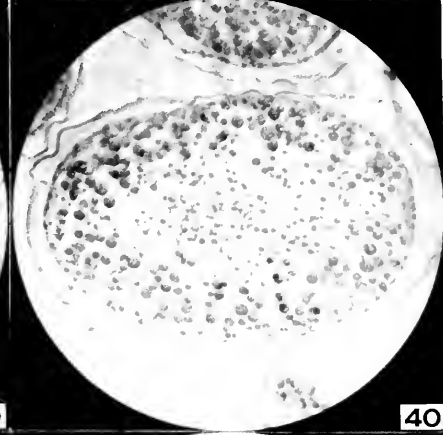

40

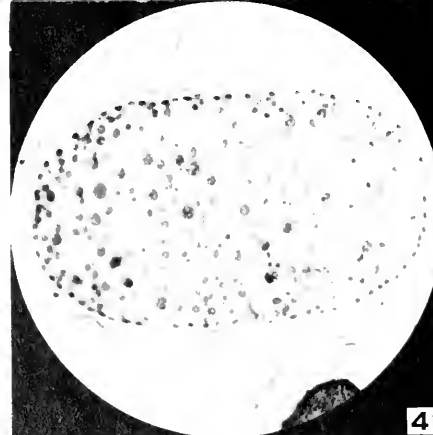

41

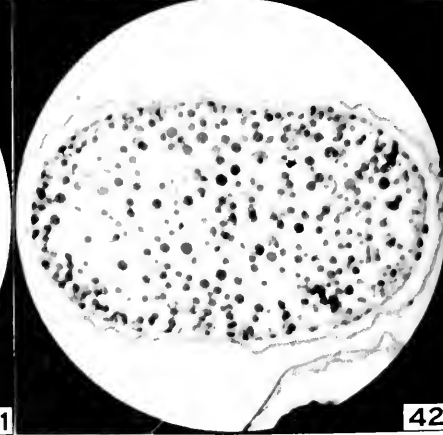

42

EMBRYOLOGY OF FLEAS  
(See explanation of plates at end of text.)

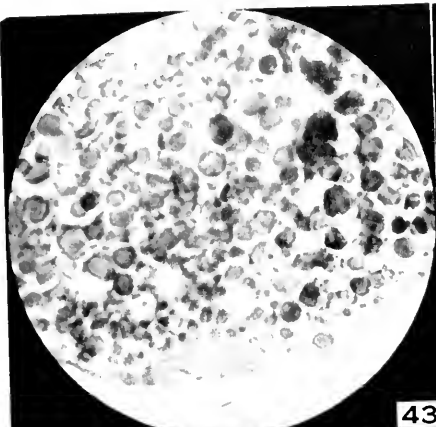

43

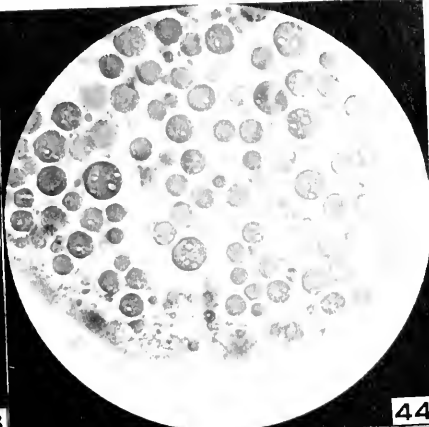

44



45



46

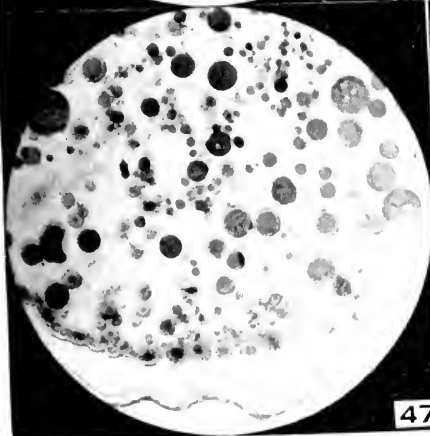

47



48

EMBRYOLOGY OF FLEAS  
(See explanation of plates at end of text.)

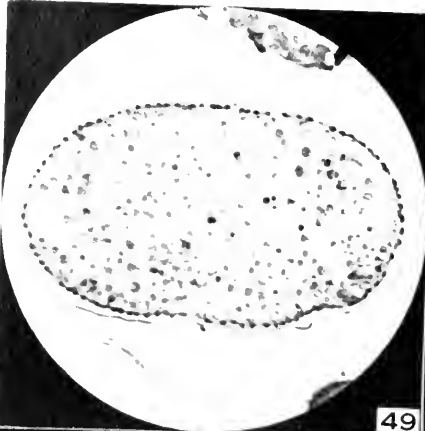

49

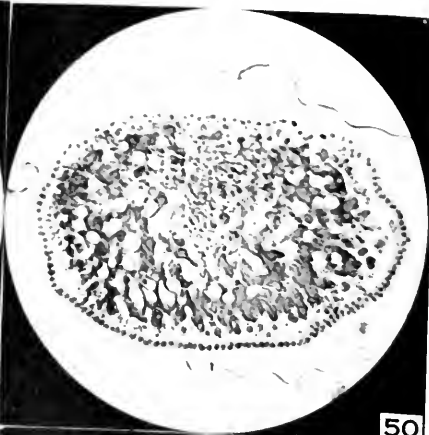

50

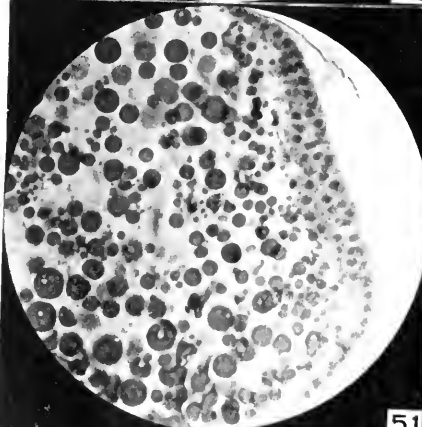

51



52



53

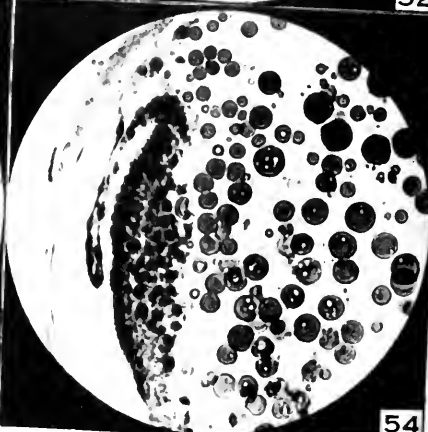

54

EMBRYOLOGY OF FLEAS  
(See explanation of plates at end of text.)



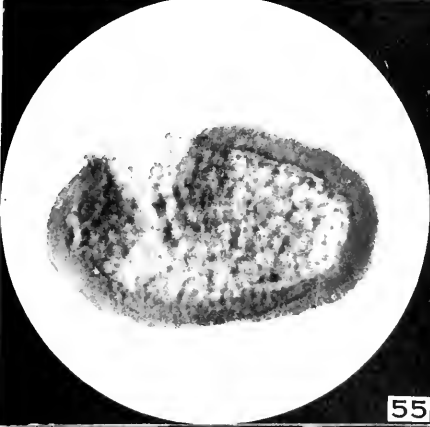

55



56



57

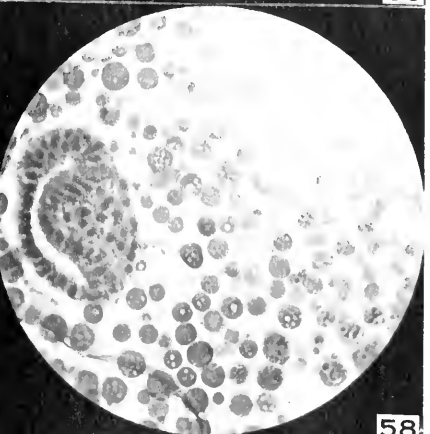

58

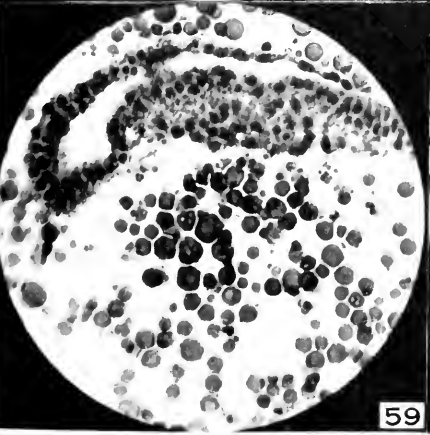

59



60

EMBRYOLOGY OF FLEAS  
(See explanation of plates at end of text.)

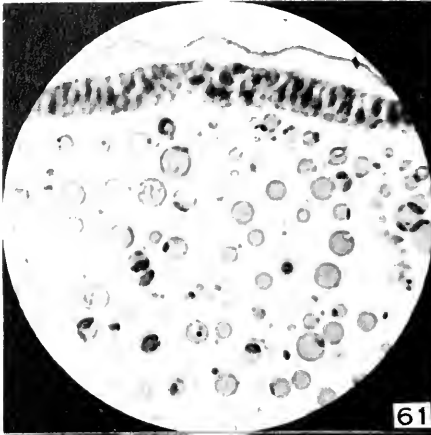

61

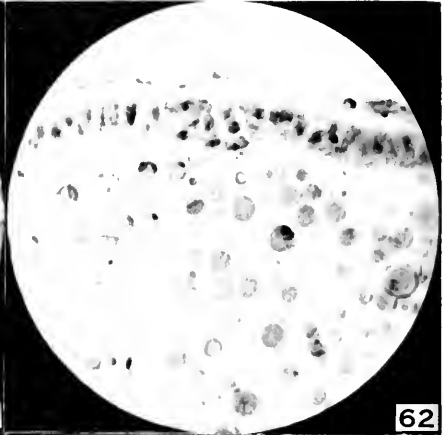

62

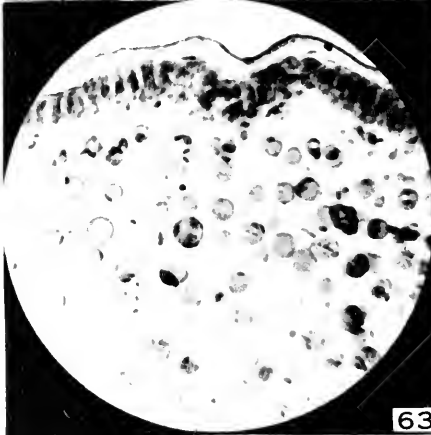

63

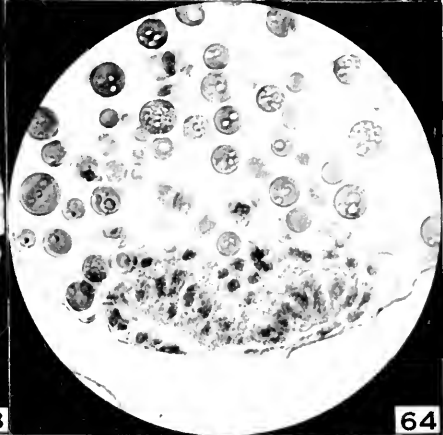

64

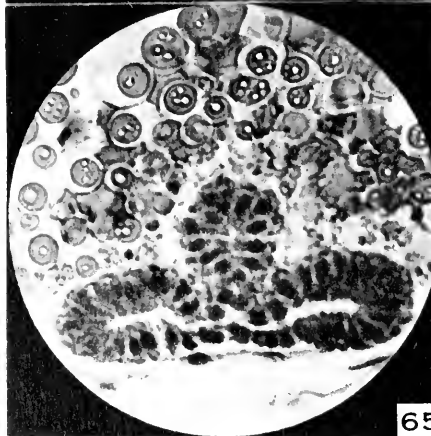

65

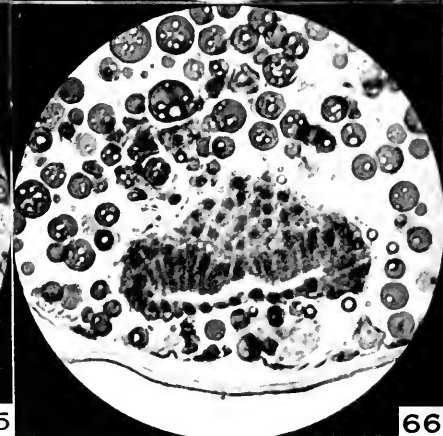

66

EMBRYOLOGY OF FLEAS  
(See explanation of plates at end of text.)



67

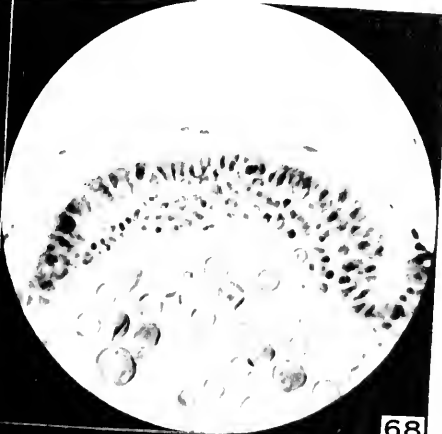

68

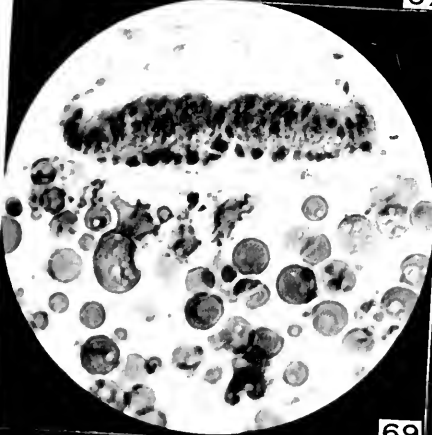

69

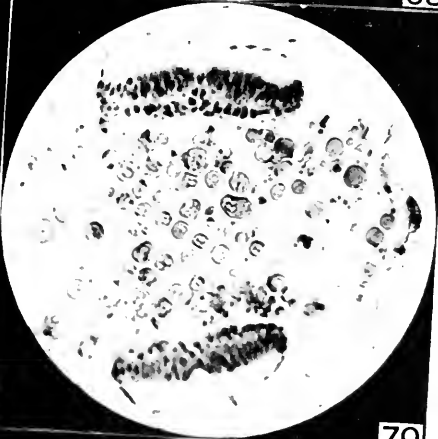

70

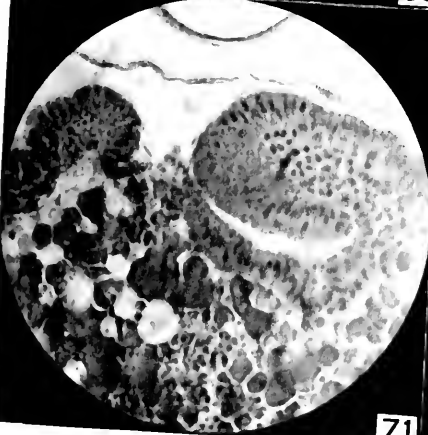

71



72

EMBRYOLOGY OF FLEAS  
(See explanation of plates at end of text.)

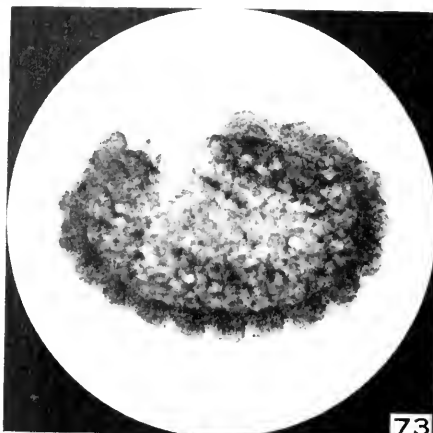

73



74

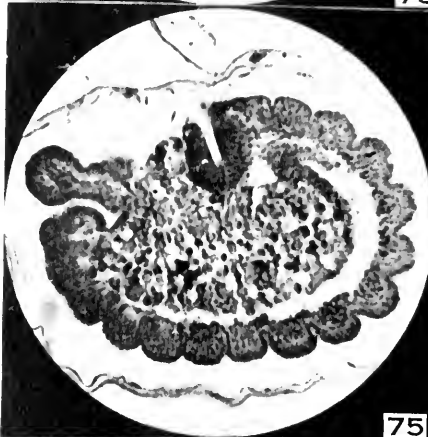

75

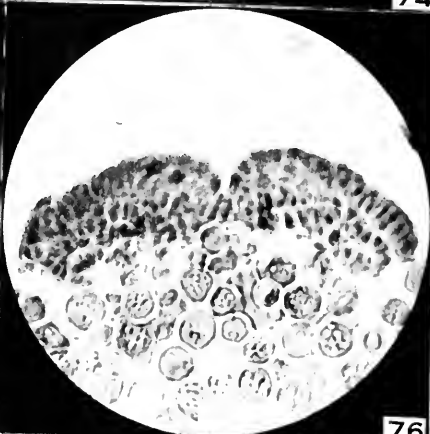

76



77

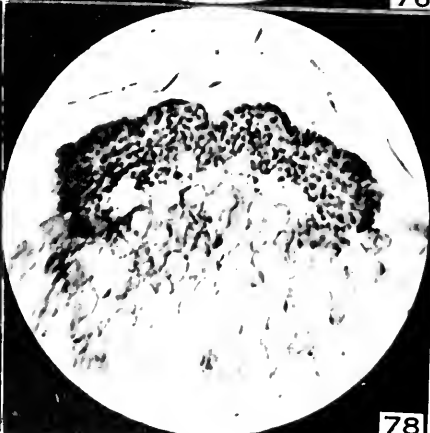

78

EMBRYOLOGY OF FLEAS  
(See explanation of plates at end of text.)

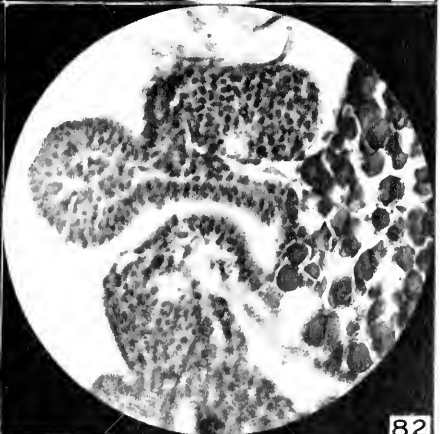
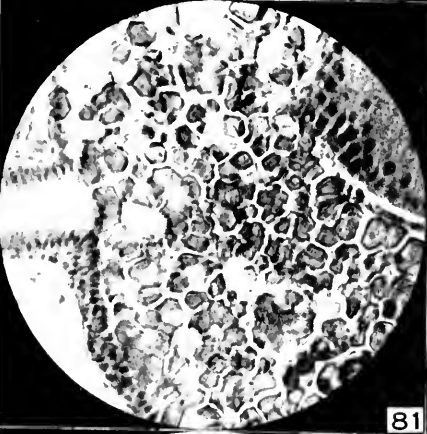
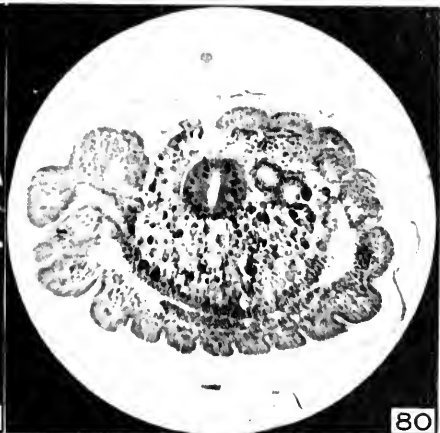

EMBRYOLOGY OF FLEAS  
(See explanation of plates at end of text.)

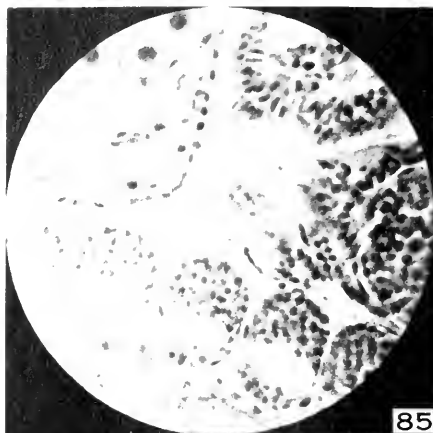

85



86

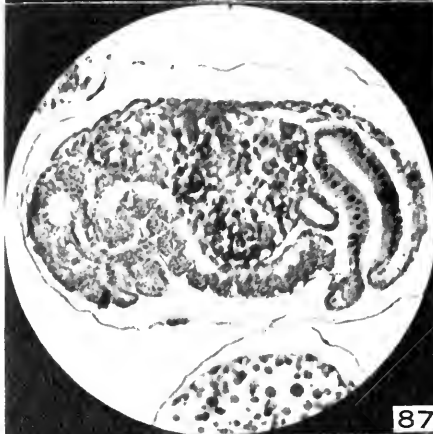

87

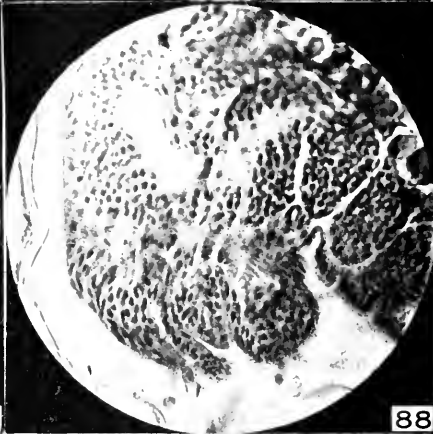

88

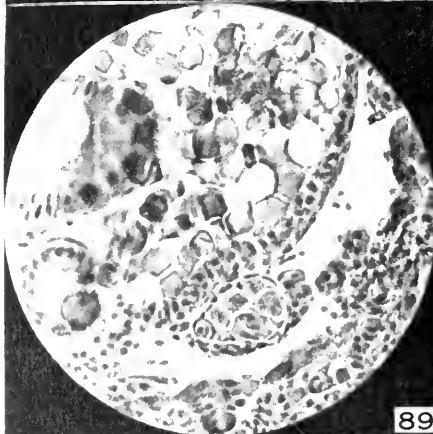

89

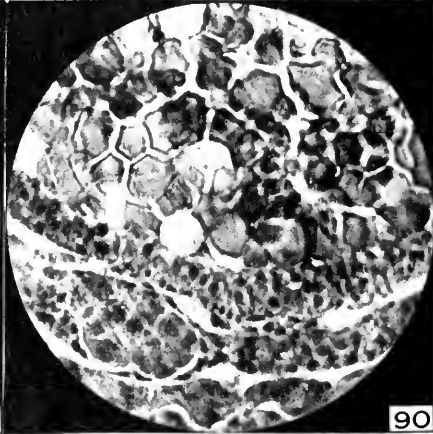

90

EMBRYOLOGY OF FLEAS

(See explanation of plates at end of text.)

SMITHSONIAN MISCELLANEOUS COLLECTIONS  
VOLUME 98, NUMBER 4

SMITHSONIAN INSTITUTION  
MAR 10 1939  
OFFICE LIBRARY

# FIVE NEW RACES OF BIRDS FROM VENEZUELA

BY  
ALEXANDER WETMORE  
Assistant Secretary, Smithsonian Institution



(PUBLICATION 3528)

CITY OF WASHINGTON  
PUBLISHED BY THE SMITHSONIAN INSTITUTION  
MARCH 10, 1939





SMITHSONIAN MISCELLANEOUS COLLECTIONS

VOLUME 98, NUMBER 4

FIVE NEW RACES OF BIRDS FROM  
VENEZUELA

BY

ALEXANDER WETMORE

Assistant Secretary, Smithsonian Institution



(PUBLICATION 3528)

CITY OF WASHINGTON  
PUBLISHED BY THE SMITHSONIAN INSTITUTION  
MARCH 10, 1939

The Lord Baltimore Press  
BALTIMORE, MD., U. S. A.

## FIVE NEW RACES OF BIRDS FROM VENEZUELA

BY ALEXANDER WETMORE

*Assistant Secretary, Smithsonian Institution*

In the course of study of a collection of birds made in northern Venezuela in 1937, several forms have been segregated that previously have not been recognized by name. They are described in the following paragraphs. During the progress of this work the author has had the advantage of examination of specimens in the American Museum of Natural History, and in the Field Museum of Natural History, for which privilege he expresses his thanks and appreciation. The new forms follow.

### BUCCONIDAE

#### **HYPNELUS BICINCTUS STOICUS**, subsp. nov.

*Characters*.—Similar to *Hypnelus bicinctus bicinctus* (Gould)<sup>1</sup> but lighter colored above, both in the ground color of the feathers, and in their lighter tips.

*Description*.—Type, U.S.N.M. no. 151670, male, Margarita Island, Venezuela, collected July 3, 1895, by Wirt Robinson (orig. no. 404). Crown slightly darker than hair brown, some of the feathers indistinctly drab at the tips; a faintly indicated spotting of avellaneous in center, just above base of bill; a very narrow line of white across forehead; stiffened bristles above nostrils white at base and black at tips; rictal bristles black, some of them white at base; lores, a line beneath the eye, and postocular space dull white, connected indistinctly with a narrow, partly concealed white band across hind-neck; sides of head above white postocular mark hair brown, washed with dull vinaceous buff; side of head at base of mandible dull fuscous, tipped posteriorly with dull vinaceous buff; hindneck, below white band, and back slightly darker than hair brown, the feathers tipped with dull white and avellaneous, producing indistinct spots; rump and upper tail-coverts fuscous, tipped slightly with vinaceous buff; wing-coverts dull hair brown, spotted indistinctly with dull white, and tipped

<sup>1</sup>*Tamatia bicincta* Gould, Proc. Zool. Soc. London, 1836 (January 16, 1837) ("Cayenne"). Hellmayr and Seilern, Arch. Naturg., vol. 78, 1912, p. 156, have designated the type locality as Venezuela.

indistinctly with vinaceous buff; primaries and secondaries fuscous, edged narrowly with pale olive-buff, these light markings prominent at the centers of the sixth, seventh, and eighth primaries; dorsal surface of rectrices fuscous, the outer one margined all around with pale olive-buff; chin white; throat ivory yellow, the feathers white basally; a broad band of fuscous across lower foreneck, continuous at sides with the dark color of the sides of the head; behind this a narrower band of white, washed lightly with cream-buff; behind this, a band of fuscous-black across the upper breast, narrower than the anterior dark band, and somewhat irregular and broken centrally; rest of under surface white washed with cream-buff, with a line of spots of fuscous-black extending from the sides toward the central part of the breast as indication of a third dark bar which, however, remains broken in the center; flanks spotted with fuscous and fuscous-black; under wing-coverts cream-buff; inner webs of primaries at base dull white; of secondaries ivory yellow; under tail-coverts cream-buff. Bill black, tarsus and toes dull brownish black (from dried skin). Iris indicated by collector as yellowish buff.

*Measurements*.—Type, male, wing 91.5, tail 85.3, culmen from base 35.7, tarsus 19.0 mm.

Males (3 specimens), wing 89.8-91.5 (90.4), tail 83.4-85.3 (84.1), culmen from base 34.2-35.7 (35.1), tarsus 19.0-20.4 (19.6) mm.

Females (6 specimens), wing 89.7-93.3 (91.3), tail 86.7-89.3 (88.5), culmen from base 35.0-37.3 (35.7), tarsus 19.0-22.1 (20.1) mm.

*Remarks*.—Separation of the Margarita Island form is made after comparison of nine specimens from the island, two in the National Museum and seven loaned by the Field Museum, and nine from the mainland of Venezuela. The paler coloration is easily evident in series and though some individuals approach rather closely, all that I have seen can be allocated properly without particular difficulty.

It may be noted that Ridgway<sup>2</sup> observed the paler coloration of the Margarita Island bird but did not have material available on which to make the separation.

## DENDROCOLAPTIDAE

### **XIPHORHYNCHUS TRIANGULARIS HYLODROMUS, subsp. nov.**

*Characters*.—Similar to *Xiphorhynchus triangularis triangularis* (Lafresnaye)<sup>3</sup> but brighter olive brown above; exposed surfaces of secondaries darker, less reddish brown; under surface lighter, more

<sup>2</sup> U. S. Nat. Mus. Bull. 50, pt. 6, 1914, p. 382.

<sup>3</sup> *Dendrocolaptes triangularis* Lafresnaye, Rev. Zool., vol. 5, 1842, p. 134 (Bogotá, Colombia).

greenish olive, more abundantly spotted, the spots lighter colored; throat decidedly lighter, with the dark marginal lines on the feathers reduced in width.

*Description*.—Type, U.S.N.M. no. 351930, male, taken in the Cordillera de la Costa at 4,500 feet elevation above Rancho Grande, Estado Aragua, Venezuela, November 8, 1937, by A. Wetmore (original no. 9881). Feathers of crown brownish olive, with a border of dull black at the tip, and a central streak of cream-buff along the shaft, this more extensive on forehead; hind neck and back dull medal bronze, the hind neck with faint shaft lines of cream-buff; upper tail-coverts dull hazel, this color extending across the rump to merge with the medal bronze of the lower back; wing-coverts dull dresden brown; secondaries mars brown, with exposed margin dresden brown, and an indistinct line of russet along the shaft; inner webs of primaries russet, becoming fuscous at the tips, with the outer web mars brown; tail chestnut-brown; shafts of primaries, secondaries, and rectrices blackish; chin whitish, unmarked; throat colonial buff, the feathers with very narrow, rather indistinct blackish margins; sides of head brownish olive, with abundant but indistinct streakings and spottings of colonial buff; under surface olive, becoming a little lighter on center of breast and abdomen, darker on sides, marked abundantly with elongated spots of marguerite yellow; under tail-coverts streaked with dull marguerite yellow; under wing-coverts dull ochraceous-orange; under surface of tail somewhat paler than mars brown. Maxilla dull blackish, with a dull ivory white line along the center of the tomium; mandible dull slate at base, light brownish white at tip; tarsus and toes dull brownish black (from dried skin).

*Measurements*.—Type, male, wing 118.4, tail 91.6, culmen from base 29.7, tarsus 22.0 mm.

Male (an additional specimen), wing 117.5, tail 90.5, culmen from base 30.3, tarsus 22.3 mm.

Females (2 specimens), wing 104.7, 109.3, tail 82.9, 89.5, culmen from base 28.5, 29.4, tarsus 22.7, 22.7 mm.

*Range*.—Mountains of northern Venezuela, known from the Cumbre de Valencia, and near Rancho Grande.

*Remarks*.—In addition to those listed, there is another specimen in which the sex could not be determined when the bird was skinned. The four secured near Rancho Grande were obtained in rain forest at elevations of from 3,700 to 4,500 feet in the Cordillera de la Costa. Hellmayr and Seilern<sup>4</sup> note of specimens from the Cumbre de

<sup>4</sup> Arch. Naturg., vol. 78, 1912, pp. 109-110.

Valencia that they have "etwas helleren und mehr grünlichbraunen Rücken" but refer their birds to typical *triangularis*. They evidently belong to the present form. There are three specimens in the American Museum of Natural History from the Cumbre de Valencia, inland from Puerto Cabello, collected by S. M. Klages that are like the skins from Rancho Grande.

**DENDROPLEX PICIROSTRIS PHALARA**, subsp. nov.

*Characters*.—Similar to *Dendroplex picirostris longirostris* Richmond<sup>5</sup> but light spots on crown and hindneck larger, the light markings more abundant on the fore part of the crown, that area appearing lighter; markings on breast more buffy in tone; averaging browner and lighter on breast.

*Description*.—Type, U.S.N.M. no. 351915, male, collected at El Sombrero, Estado Guarico, Venezuela, November 14, 1937, by A. Wetmore (original no. 9962). Forehead and lores between cartridge buff and cream-buff; entire crown with large, tear-shaped markings of cartridge buff and cinnamon-buff covering the center of each feather, bordered with chaetura drab; feathers of hindneck and extreme upper back with large, elliptical central markings of cinnamon-buff bordered narrowly with dull black, and edged with snuff brown; entire side of head cartridge buff; upper back snuff brown, merging into russet, this color extending over the rest of the upper surface, including the wings and tail; rump verging toward tawny; throat and foreneck white with a wash of cartridge buff; extreme upper breast the same, with a few scattered, newer feathers of cinnamon-buff; a little lower down the feathers broadly cinnamon-buff centrally, with narrow borders of dull black, and an edging of saccardo's umber; central and lower breast and sides with the light central markings narrowed and elongated, and the brown edgings broader; abdomen saccardo's umber with a few indistinct central markings of cinnamon-buff and equally indistinct mottlings of chaetura drab; under tail-coverts sayal brown, slightly brighter, more cinnamon-buff along shafts; sides and flanks russet; under wing-coverts light cinnamon; under surface of remiges cinnamon, becoming fuscous at tips; under surface of tail verona brown. Bill pale smoke gray, with a faint line of fuscous along culmen, the base with a tinge of dull buff; tarsus and toes blackish brown, nails fuscous (from dried skin).

<sup>5</sup> *Dendroplex longirostris* Richmond, Proc. U. S. Nat. Mus., vol. 18, 1896, p. 674 (Margarita Island, Venezuela).

*Measurements.*—Type, male, wing 97.3, tail 83.3, culmen from base 30.0, tarsus 22.7 mm.

Male (a second specimen), wing 99.7, tail 81.3, culmen from base 30.7, tarsus 24.5 mm.

Females (2 specimens), wing 101.2-102.5, tail 82.0-84.1, culmen from base 32.2-33.6, tarsus 23.6-25.1 mm.

*Range.*—Known from Parapara and El Sombrero, Estado Guarico, Venezuela. Supposed to extend through the northern Llanos.

*Remarks.*—This new form shares with the race *longirostris* a larger bill and an extension of the light markings over the upper breast. It differs from *picrostris* (in which this light area is more restricted) in having the dark-bordered, light streakings extending farther down across the breast, the auricular region lighter, the forehead paler, and the dark-bordered, light markings on the hindneck greater in extent and the bill heavier.

## TYRANNIDAE

### PYRRHOMYIAS VIEILLOTOÏDES SPADIX, subsp. nov.

*Characters.*—Similar to *Pyrrhomyias vieillotoïdes vieillotoïdes* (Lafresnaye)<sup>6</sup> but dorsal surface lighter; dark feathers of pileum browner, less blackish; below lighter, especially on the abdomen, flanks and under tail-coverts; size slightly greater.

*Description.*—Type, U.S.N.M. no. 171139, male, collected at Los Palmales, elevation 450 meters, Estado Monagas, Venezuela, December 7, 1898, by F. W. Urich (original no. 48). Pileum (except in center) and hindneck mummy brown; a concealed crown patch strontian yellow, the feathers white basally; upper back between russet and cinnamon-brown; lower back sepia; rump somewhat dull yellow ocher, this color confluent with the flanks, forming a distinct band; upper tail-coverts auburn; wing-coverts black basally, this color entirely hidden by auburn tips on the lesser coverts; middle and greater wing-coverts edged broadly with hazel; primaries dull black at tips and on outer webs of sixth to tenth, with the inner webs and the basal parts of the outer webs hazel, except on eighth and ninth where there is a mere trace of this color; outer web of tenth primary edged with hazel for basal two-thirds; secondaries hazel with tips black, except for a narrow tip and edging of the brighter color; central rectrices dull black, tipped and margined narrowly with hazel; other rectrices dull black distally with the bases, external edging, and narrow tips hazel;

<sup>6</sup>*Muscicapa (Tyrannula) vieillotoïdes* Lafresnaye, Rev. Zool., vol. 11, 1848, p. 174 (Caracas, Venezuela).

throat cinnamon-brown, the feathers grayish black basally; sides of head cinnamon-brown; foreneck and most of breast hazel, becoming clay color on lower breast, flanks, abdomen and under tail-coverts; under wing-coverts ochraceous-tawny. Bill and tarsus dull black (from dried skin).

*Measurements*.—Type (male), wing 72.3, tail 60.4, culmen from base 13.8, tarsus 12.6 mm.

Males (7 specimens), wing 69.8-74.3 (72.2), tail 57.3-60.4 (59.1), culmen from base 13.3-14.7 (13.9), tarsus 12.3-12.6 (12.5).

Females (4 specimens), wing 66.9-70.0 (68.6), tail 52.8-56.2 (54.4), culmen from base 13.2-14.5 (13.9), tarsus 12.5-13.4 (12.9) mm.

*Range*.—Mountains of Monagas (and probably Sucre), northeastern Venezuela (Los Palmales near San Antonio, Santa Ana Valley, Los Dos Ríos).

*Remarks*.—This new form follows a tendency to paler coloration found in various species in the Cumaná region. *P. v. assimilis* of the Santa Marta region is decidedly brighter rufous above, with the light rump band rufescent rather than buffy. I have had available skins of *P. v. vicillotoïdes*, from the Silla de Caracas, Galipán in the Cerro de Avila, Los Riños near Rancho Grande in the Cordillera de la Costa, and from the Cumbre de Valencia. It is interesting to note that two skins in the American Museum of Natural History from the mountains at Bucarito, near Tocuyo in Estado Lara, while to be placed with the race *vicillotoïdes*, are distinctly paler and so superficially resemble *spadir*, owing to their approach to the more rufescent *assimilis* of the Santa Marta region.

Measurements of typical *vicillotoïdes* are as follows:

Males (4 specimens), wing 68.1-70.5 (69.2), tail 56.2-59.7 (57.7), culmen from base 13.4-13.6 (13.5), tarsus 12.8-13.4 (13.1) mm.

Females (2 specimens), wing 65.8-66.8 (66.3), tail 52.9-53.2 (53.0), culmen from base 13.4-13.7 (13.5), tarsus 12.8-13.1 (12.9) mm.

#### CAPSIEMPIS FLAVEOLA CERULA, subsp. nov.

*Characters*.—Similar to *Capsiempis flaveola flaveola* (Lichtenstein)<sup>1</sup> but lores and feathers behind nostrils distinctly white or whitish (less yellowish); throat white.

*Description*.—Type, U.S.N.M. no. 352009, male, collected at Independencia, Ocumare de la Costa, Estado Aragua, Venezuela, October 28, 1937, by A. Wetmore (original number 9714). Crown dark yel-

<sup>1</sup> *Muscicapa flaveola* Lichtenstein, Verz. Doubl. Zool. Mus. Berlin, 1823, p. 56 (Bahia, Brazil).



lowish olive, the feathers edged with yellowish olive; lores and space behind nostril white with a faint yellowish tinge, forming a distinct spot, somewhat obscured by blackish hairs; back and rump yellowish olive; upper tail-coverts lighter, approaching light yellowish olive; lesser wing-coverts yellowish olive; middle and greater coverts chaetura drab, tipped with reed yellow to primrose yellow, forming two distinct wing-bands; primary coverts and alula chaetura drab; primaries and secondaries chaetura drab, outer webs edged with yellowish olive changing to reed yellow; inner secondaries edged with marguerite yellow; rectrices dark hair brown, with a very narrow edging of reed yellow basally; superciliary line reed yellow, somewhat obscured by yellowish olive tips to feathers; auricular region, light yellowish olive, with a spot of yellowish olive above and directly behind eye; chin and throat white, with a very slight yellowish tinge; upper breast strontian yellow, becoming yellowish citrine at sides; foreneck, lower breast, abdomen and under tail-coverts dark citron yellow; sides pale olive-yellow; under wing-coverts barium yellow, marked with chaetura drab along bend of wing. Maxilla dull black, tip of mandible chaetura black, base deep olive-buff, tarsus and toes chaetura black (from dried skin).

*Measurements*.—Type, male, wing 51.3, tail 50.1, culmen from base 11.4, tarsus 16.9 mm.

Males (9 specimens), wing 50.5-52.8 (51.6), tail 48.6-52.4 (50.1), culmen from base 10.7-11.6 (11.2), tarsus 16.8-17.4 (17.0) mm.

Females (9 specimens), wing 47.0-52.2 (49.3), tail 46.3-49.5 (47.7), culmen from base 10.7-11.9 (11.4), tarsus 15.9-17.2 (16.5) mm.

*Range*.—Venezuela, including the Orinoco and Caura Valleys, and the northern portion west at least through Estado Aragua.

*Remarks*.—From *Capsicmpis flavcola leucophrys* the present form is distinguished by less extensive white on throat, brighter yellow underparts, brighter green dorsal surface, and slightly smaller size. In five Bogotá skins of *leucophrys* with the sex not indicated the wing ranges from 55.2 to 56.8 mm., which is distinctly larger than the dimensions given above regardless of sex.

In size the new form resembles typical *flavcola* from Bahia. The more typical specimens come from the northern section of Venezuela, skins from the Orinoco basin being slightly intermediate toward *flavcola* but to be placed with the present form. Specimens assigned to the new race have been seen from the following localities: Ocumare de la Costa (Estado Aragua); Cumanacoa (Estado Sucre); Ciudad Bolívar, Altgracia, Maipures, and Suapure along the Río Orinoco, and La Prición in the Caura Valley.



SMITHSONIAN MISCELLANEOUS COLLECTIONS  
VOLUME 98, NUMBER 5

# UTILIZING HEAT FROM THE SUN

(WITH FOUR PLATES)

BY  
C. G. ABBOT  
Secretary, Smithsonian Institution

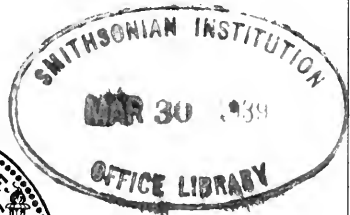

(PUBLICATION 3530)

CITY OF WASHINGTON  
PUBLISHED BY THE SMITHSONIAN INSTITUTION  
MARCH 30, 1939



SMITHSONIAN MISCELLANEOUS COLLECTIONS  
VOLUME 98, NUMBER 5

# UTILIZING HEAT FROM THE SUN

(WITH FOUR PLATES)

BY  
C. G. ABBOT  
Secretary, Smithsonian Institution



(PUBLICATION 3530)

CITY OF WASHINGTON  
PUBLISHED BY THE SMITHSONIAN INSTITUTION  
MARCH 30, 1939

The Lord Baltimore Press  
BALTIMORE, MD., U. S. A.

## UTILIZING HEAT FROM THE SUN

BY C. G. ABBOT,  
*Secretary, Smithsonian Institution*

(WITH FOUR PLATES)

In large regions lying in the low latitudes desert conditions prevail. Day after day the sun glares down, occasionally dimmed a little by cirrus clouds, or perhaps by a few heaping cumuli. In such regions 80 percent or even more of the hours of daylight would be useful for furnishing solar heating.

### QUANTITY OF SOLAR ENERGY

The quantity of energy available from solar radiation under such conditions as I have pictured is immense. As I shall show in what follows, we may count on the possibility of converting 15 percent of the energy of such solar rays as are intercepted by our devices into mechanical work. Assuming that to avoid appreciable losses through shading one unit by another, and to allow plenty of room for other purposes, only one-tenth of the area available is actually covered by heat collectors, and further allowing for night and cloudy weather, still the State of New Mexico could supply from solar radiation over ten trillion horsepower-hours per year of mechanical power, which compares with the power possibilities of all coal, oil, and water at present used annually for heat, light, and power combined in the United States.

### INTERMITTENCE AND STORAGE OF SOLAR POWER

Like hydroelectric power, solar power demands no continuing expense other than for care and interest on the investment. Unfortunately, however, solar power is subject to the drawback that it ceases during night hours, and when the beam is intercepted by clouds. There are certain uses, such as pumping water for irrigation for instance, where this intermittence is no serious objection. But for most purposes power must be available at all times. Hence to become a great industrial factor solar power demands the association of storage of energy, either as heat, or in chemical, electrical, or

mechanical forms. As efficient production of solar power must nevertheless be the first step, I shall postpone considerations of storage for the present.

#### WATER DISTILLING AND COOKING BY SOLAR HEATING

There are other uses for solar heating which do not so much involve storage. Among them are the distillation of water and the cooking of food. It is stated that in Bermuda the past year was so deficient in rainfall that fresh water was imported from New York, although the Atlantic ocean is all around. In some of our western States the water in many parts is too alkaline for drinking or for storage batteries. In Florida the water in some localities stinks with hydrogen sulphide. Under such conditions as these the solar distilling device should be useful. As for cooking, though not practical in cloudy regions, it is easy to provide heat storage for 24 hours, and with a solar cooking device the ovens may be kept at baking temperatures for weeks and months continuously in the more cloudless parts of our country.

#### RECENT COMMERCIAL PRODUCTS A BOON TO SOLAR DEVICES

The cheap production of efficient solar heat devices has awaited the commercial development of aluminum products, now so plentifully used in the industries, and the common use of vacuum devices, which came with the incandescent lamp and radio industries. Formerly, inventors relied on glass mirrors which were heavy, costly, and not durable. It is now possible to purchase the so-called "Alcoa" in thin sheets, which readily take the curvature of a suitable cradle form without previous shaping. This material reflects over 80 percent of solar radiation, and may be used for years without dimming. As the loss of heat in the boiler at the focus of a solar-radiation appliance is the great obstacle to be provided against, the possibility of making cheap glass jackets enclosing high vacua like thermos bottles is the other great improvement which has become practicable in recent times.

#### MCHANISM FOR FOLLOWING THE SUN

The daily march of the sun through the sky, and its yearly march from north to south, must be considered. If one uses a spherical boiler and a circular mirror, he must allow for both of these apparent motions as Eneas did at the ostrich farm, Pasadena, about 1905. If, however, one uses a tubular boiler parallel to the axis of the earth,



the yearly adjustment is unnecessary and the daily motion can be allowed for by merely rotating the parabolic cylindrical ray-concentrating mirror about an axis coincident with that of the boiler tube at the rate of  $15^\circ$  per hour. In this arrangement the boiler tube may be firmly fixed. This, with the simplicity of the mechanical driving of the mirror, renders this arrangement preferable to all others for most purposes. The mirror may be driven by clockwork, or, if electric facilities are available, still better by a 60-cycle synchronous motor through a worm and wheel.

I have used both types of driving. Our solar cooker on Mount Wilson, having been built long ago, is cumbersome. It has a heavy mirror, 8 feet wide by 12 feet long. I attached to the mirror a grooved wheel 30 inches in diameter coaxial with the lower trunnion of the mirror. A steel wire in the groove of the wheel supported a weight of about 200 pounds, sufficient to rotate the mirror toward the west. Through a second steel wire wound in the groove in the opposite sense, the weight also drove a clockwork. This clockwork train ended in a flyvane. A long hand rotated with the central shaft and once in each revolution was stopped by a displaceable pin. The long hand would make a full rotation in about 3 minutes. A common alarm clock was provided with a wheel of 12 pins on the back of its hour shaft, and these pins, acting through a lever escapement displaced the stop-pin once each 5 minutes. Hence the mirror moved intermittently as governed by the alarm clock, and was never more than 1 minute from its proper position to focus sun rays upon the heater tube. Still simpler clockwork contrivances may be used to drive smaller mirrors for solar heating devices.

#### DOMESTIC WATER HEATERS

Those who have visited Florida or southern California may know of the roof water heaters which are used considerably for providing hot water for bath and other household purposes. A shallow depression is let into the south roof exposure, and lined with blackened sheet metal. Therein is supported a blackened grid of pipes like a steam radiator. The boxlike depression is covered tightly with glass windows. Water circulates through the piping, and thence to a reservoir at a higher level within the house. Such a system acts by gravity like the water heater system of a cook stove. If the reservoir is well insulated from heat losses and the location is relatively cloudless and never freezing, such a system is found to be very useful for furnishing hot water both day and night, without maintenance

cost or attention. While on Mount Wilson, several years ago, I bought 200 feet of black garden hose. I coiled 150 feet of it in a flat coil upon a wooden X, and carried it up the ladder to the south side of the cottage roof. The other 50 feet I connected to the water hydrant in the yard and to a spigot in the bathtub. By this simple arrangement we could draw 5 gallons of very hot water each half hour on every sunny day.

#### SOLAR COOKERS

When we attempt cooking by sun heating we require temperatures far above the boiling point of water. Hence some other liquid of a much higher boiling point is desirable as a heat conveyor, otherwise high pressures and evaporation would be met with. In our cooker on Mount Wilson I used engine cylinder oil within a blackened metal tube in the focus of the mirror. About 60 gallons of this oil were employed in the system, so that there was a large capacity for heat, and cooking could be done by night as well as by day. However, it required about 2 days of sun to get the system heated initially, for owing to nearby trees there were only 7 hours per day of sunshine. In recent installations I have preferred to use "Arochlor," a nearly black liquid product of the Monsanto Chemical Company. I have made this liquid almost completely absorptive of sun-rays by adding a small amount of lampblack in suspension therein. While engine cylinder oil chars somewhat, and evaporates considerably at 210° C., "Arochlor" does not boil below 350° C., and evaporates scarcely any at lower temperatures. This liquid, being highly absorptive, may be used directly in the vacuum-jacketed glass focus tube. Circulation may be provided by bringing back from the oven sheath a small metal or glass tube within the focus tube to near its lower end. Such a focus tube passes freely through the hollow trunnion at the upper end of the mirror, and is sealed by a well-designed stuffing box to the metal sheath which encloses the oven. According as one wishes for a quickly heating oven, or on the other hand for one to remain hot through temporary cloudiness and the night hours, the oven sheath contains little or much of the liquid. This part of the system may be surrounded by a thick layer of glass wool for insulation, leaving, of course, means for reaching the oven door.

In another embodiment of the cooking device, I have sealed the glass vacuum-jacketed focus tube to a vertical cylindrical glass jar to contain the liquid. Within the liquid is an inner glass jar used as the oven. The oven is approached from above with food to be cooked.

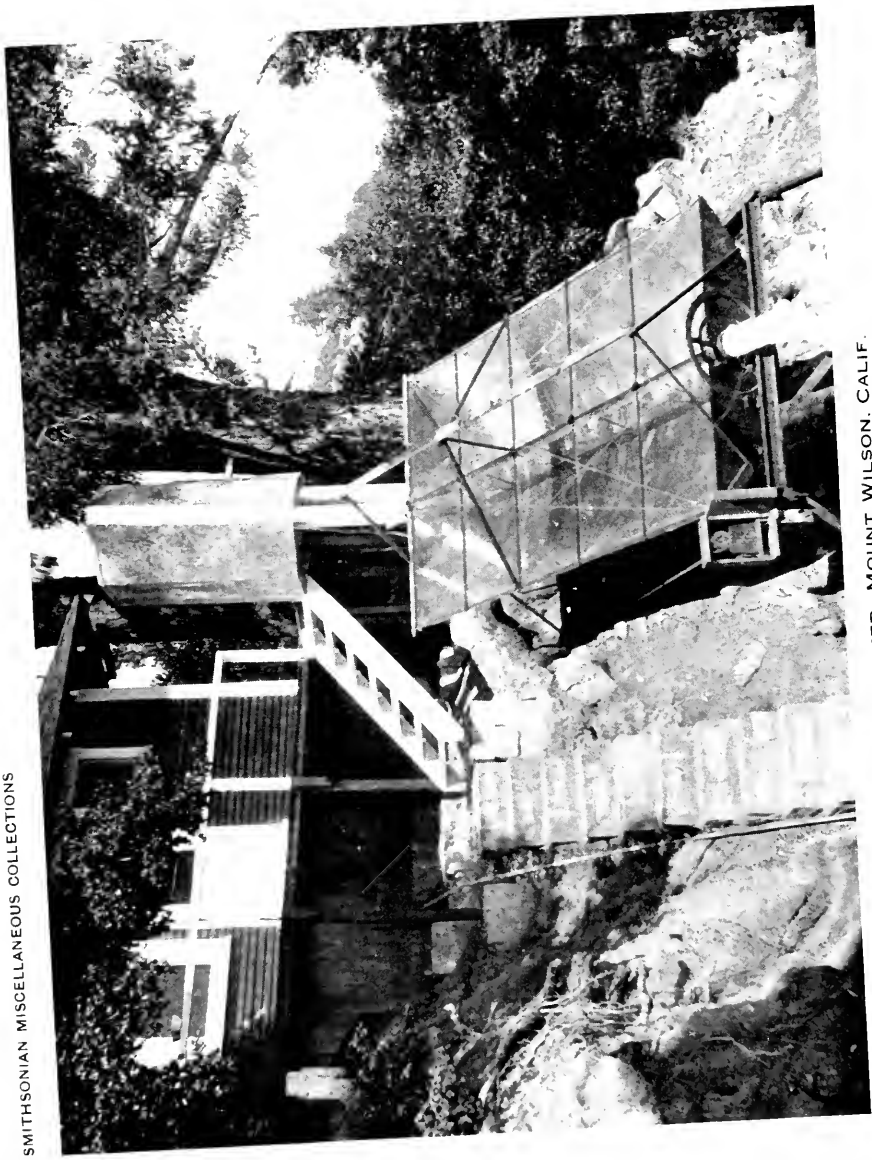

SOLAR COOKER. MOUNT WILSON, CALIF.

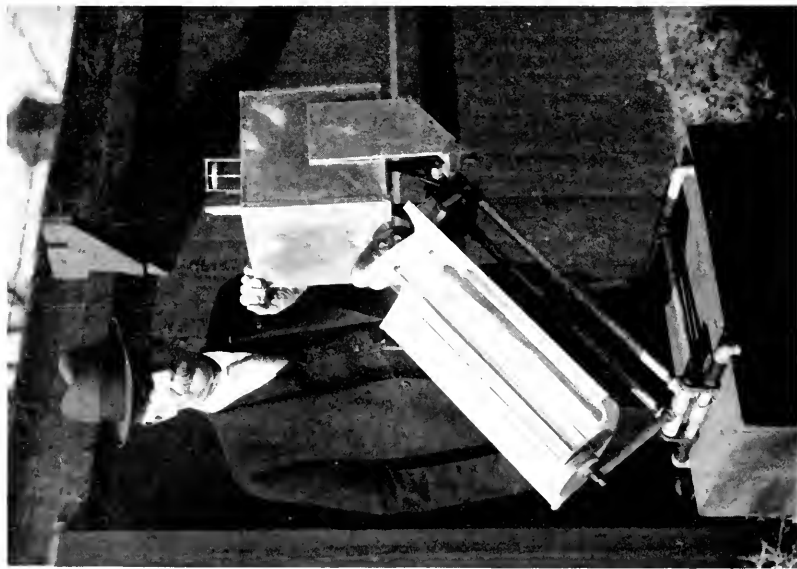

1. TOY SOLAR COOKER

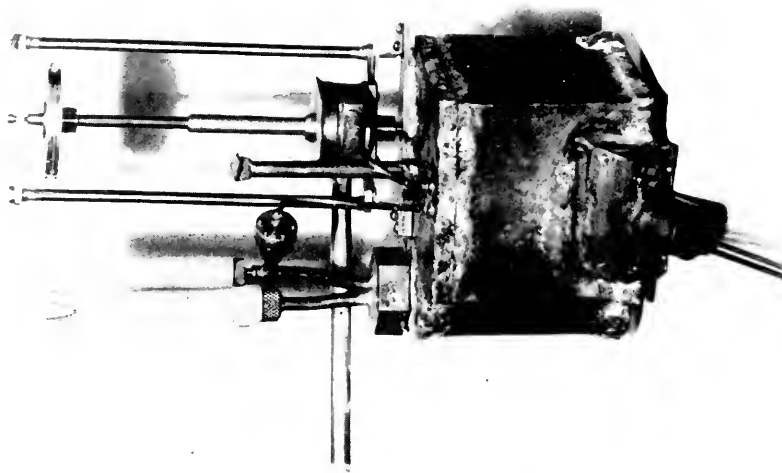

2. OVEN AND ENGINE OF TOY SOLAR COOKER

In this embodiment the outer of these two glass cylinders may be itself surrounded by evacuated space. This makes a very beautiful and highly efficient, quickly heated oven of small capacity. For a large installation it is better not to use the liquid directly as the absorbing medium, but to contain it in a blackened copper tube, itself surrounded by a vacuum jacket of glass. This arrangement lends itself to a more robust connection of the heater tube to the oven jacket. Liquid may then be supplied to give a large capacity for heat and to heat a plurality of ovens.

To fix approximately our ideas of the size of an outfit for solar cooking, I give the following figures. In clear sky conditions one may depend on from 1.2 to 1.4 calories per square centimeter per minute of energy in the solar beam. Using the lower of these figures we have still to encounter the following losses. Mirror reflection 82 percent, vacuum jacket transmission, if direct to liquid, about 89 percent, if through a blackened metal tube to liquid about 80 percent. Hence there remains about 0.79 to 0.87 calory per square centimeter per minute. The maximum temperature which a mirror will maintain in an oven depends on the rate of loss of heat. The time required to approach that temperature depends on the capacity of the oven and its surroundings for heat. These variables I cannot, of course, predict without specifications. But it may safely be said that, with good design, a mirror of  $4 \times 8$  feet surface will keep two ovens of ordinary size hot enough to bake biscuits well, by night as well as by day, in any fairly cloudless regions in the temperate zones.

#### TOY SOLAR COOKER

I have constructed a toy cooker with a mirror surface of  $15 \times 20$  inches to warm an oven  $3\frac{1}{4}$  inches square,  $2\frac{1}{2}$  inches high, and insulated by 3 inches in thickness of glass wool. It requires about an hour to heat the oven to about  $130^{\circ}$  C. above surrounding temperatures, and the oven bakes cakes 3 inches square very nicely in a half hour.

#### SOLAR WATER DISTILLING

Distillation of water may be very efficiently done with solar heating. The arrangement of the mirror is similar to that just described for cooking purposes. In this case, however, the elongated vacuum jacket, like a thermos tube except that it is not silvered within, is supported in the focus of the mirror with its open end at the bottom, and its closed end extending a foot or more above the top of the mirror, which rotates on rollers bearing the hollow trunnions of the

mirror. In the case of the cooker, and also of the power flash boiler, soon to be described, the absorber of rays is made as small in diameter as possible in order to reduce heat losses, so that the temperature may run high. In the solar water distiller, however, the temperature cannot exceed the boiling point of water. With a vacuum jacket surrounding the focus tube, heat losses at that temperature are small per unit area. Hence the focus tube is made much larger in diameter in order to provide freer escape for steam. This requires a larger vacuum jacket than in the devices for cooking and for power.

I pour the water to be distilled into a vessel supported behind the mirror and nearly at the level of the upper end of the mirror. A long snout runs from the bottom of the water vessel down behind and parallel to the mirror, and, bending at right angles, comes up to join the focus tube of copper, which is blackened outside to absorb solar rays. Thus the water flows by gravity from the vessel to an equal height within the focus tube. Within this snout and focus tube is a smaller tube for steam. It extends from above the level of the water in the vessel to above the level of the mirror in the focus tube. It is open to the atmosphere above the vessel, and open to steam above the water in the focus tube. A branch leaves the steam tube at its lowest point, and passes sealed through the wall of the snout, so that distilled water may drop from the steam tube into a receptacle underneath.

Only one difficulty is met with in this device. The steam must be caused to escape by such a protected orifice that the surging, boiling water within the focus tube does not ever reach that orifice to mingle with the condensed steam. This is accomplished by a series of umbrella diaphragms along the upper part of the steam tube, and by using a diminished orifice, well shielded by a cap.

The efficiency of the device is very high. The steam being condensed by flowing through the entering water, that water reaches the lower end of the boiler tube at almost boiling temperature. Thus it is only the latent heat of steam that must be provided by solar radiation, and not the heat required to raise water to boiling. In experiments made in Florida in March 1938, the stinking water of Arcadia was distilled to perfect purity and odorlessness. Distillation commenced within 5 minutes after the sun came out of a cloud. A mirror of 11 square feet of surface distilled between 2 and 3 gallons of water, entirely automatically in one cloudless day.

## THE SOLAR FLASH BOILER FOR POWER

Since cumulus clouds are apt to obscure the sun occasionally in regions suited to solar power production, the flash boiler, rather than the boiler of large heat capacity, is indicated. For if it takes an hour or more to raise the desired steam pressure, many days will be wasted when the sky about the sun is clear one half of the time. Accordingly my efforts in recent months have been directed toward the develop-

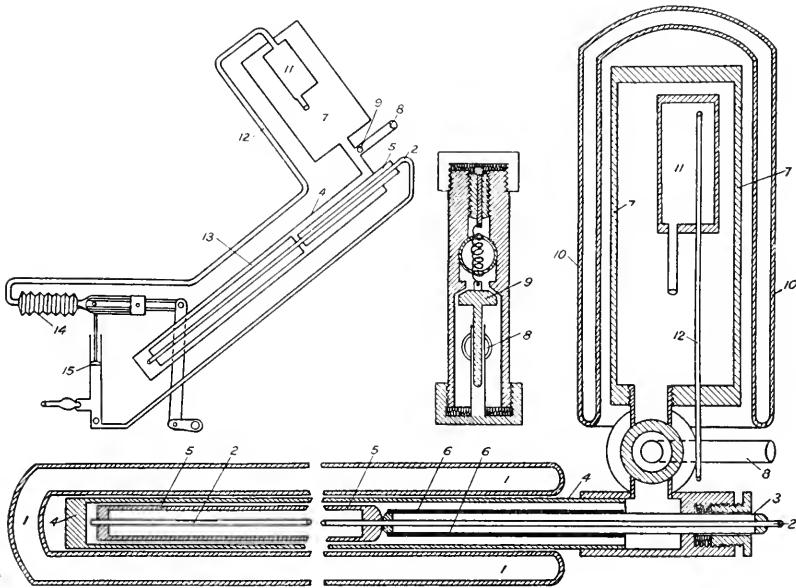

FIG. 1.—Diagram of solar flash boiler showing water injection governed directly by steam pressure. In a later model the water injection is governed by the temperature expansion of the boiler tube.

ment of the automatic flash-boiler solar engine. That is, an engine of a single tube boiler protected from heat losses by an elongated glass vacuum jacket, and fed by a current of water automatically graduated in flow by the temperature of the boiler. The device is intended to raise full steam pressure within 5 minutes after solar exposure. Should the sun enter a cloud, the water supply is immediately cut off. Should the steam pressure rise above the desired maximum, the water supply is increased. Thus the boiler is fully automatic, and it takes advantage of all the clear sky which comes between clouds.

## FLASH-BOILER DEVICES

It would be convenient if it were practicable to have the glass vacuum jacket open at both ends so that water could flow in at the bottom and go out as steam at the top. But the unequal linear expansion of the inner and outer tubes of the glass jacket is difficult to allow for in a permanent sealage. Accordingly, I have preferred to make the vacuum jacket, surrounding the boiler tube, like an elongated thermos bottle with open end up. This requires the water tube entering at the top to pass through the steam to the lower end of the boiler. I introduce two metallic tubes sealed upon the water tube within the boiler, called, respectively, the spreader tube and the vacuum jacket tube. The spreader tube encloses the water tube in the lower two-thirds of the length of the boiler tube, and forces the water to circulate in a thin layer against the inner wall of the boiler tube, so as to be most favorably situated to burst into steam. The vacuum jacket tube is sealed upon the water tube in the upper one-third of the length of the boiler tube, so as to reduce the tendency of the entering water to cool the superheated steam in the upper part of the boiler tube.

## AUTOMATIC REGULATION OF FLOW OF BOILER WATER

I accomplish automatic regulation of the water supply as follows: A pump is provided whose stroke is continuously adjustable between the limits zero and the greatest required. The essence of this regulation consists in an eccentric pin forming part of a shaft driven by the same small synchronous motor that rotates the mirror. One end of the pin is coaxial with the shaft bearings, but the other end revolves in a small orbit. The shaft carrying the pin is mounted in a carriage, displaceable longitudinally, so that according to its longitudinal position the pin gives more or less throw to the pitman that works the pump.

To govern the position of the carriage I impart motion by a screw, driven by a tiny direct-current motor operated by dry cells. The operation of this motor forward or backward is governed by a suitable multiple contact switch. The switch is operated by a lever system worked by the differential expansion between the boiler tube and an invar tape attached to the lower end of the boiler tube. Hence the temperature of the boiler, which is the index of the prevailing steam pressure, governs the position of the carriage. There is mounted upon this carriage the uniformly rotating eccentric pin, and this in turn governs the stroke of the pump which forces water into the boiler.



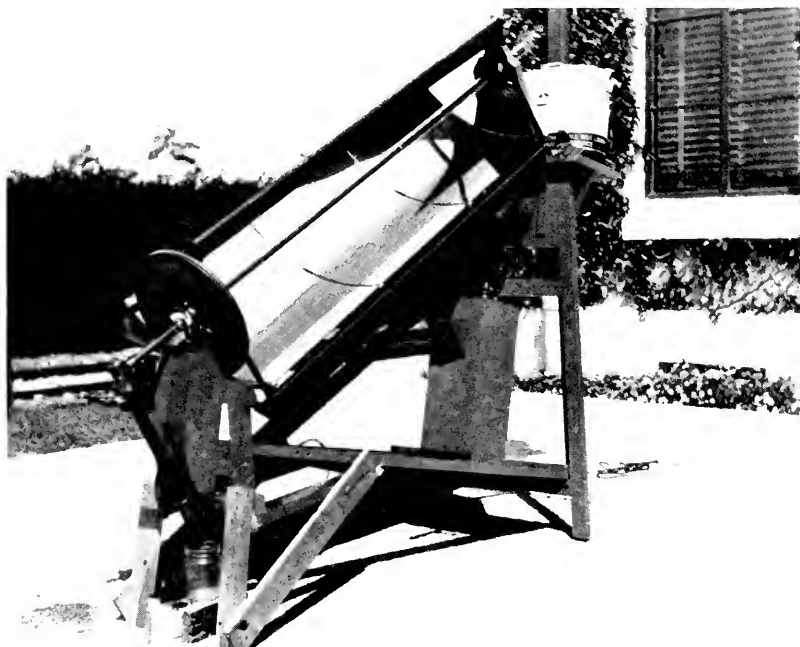

1. SOLAR WATER DISTILLER AS USED IN FLORIDA 1938

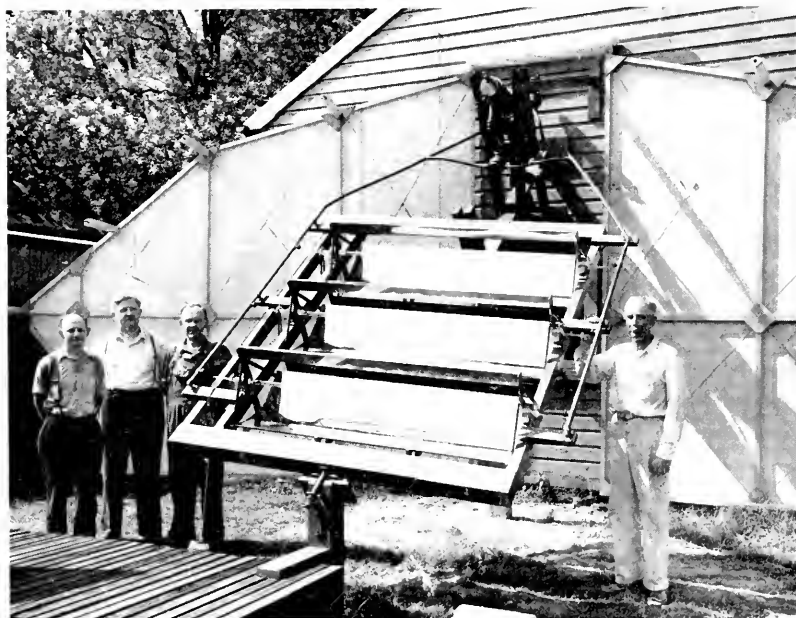

2. SOLAR BOILER FOR  $\frac{1}{2}$  HORSEPOWER ENGINE AS EXHIBITED TO INTERNATIONAL POWER CONGRESS AT WASHINGTON 1936

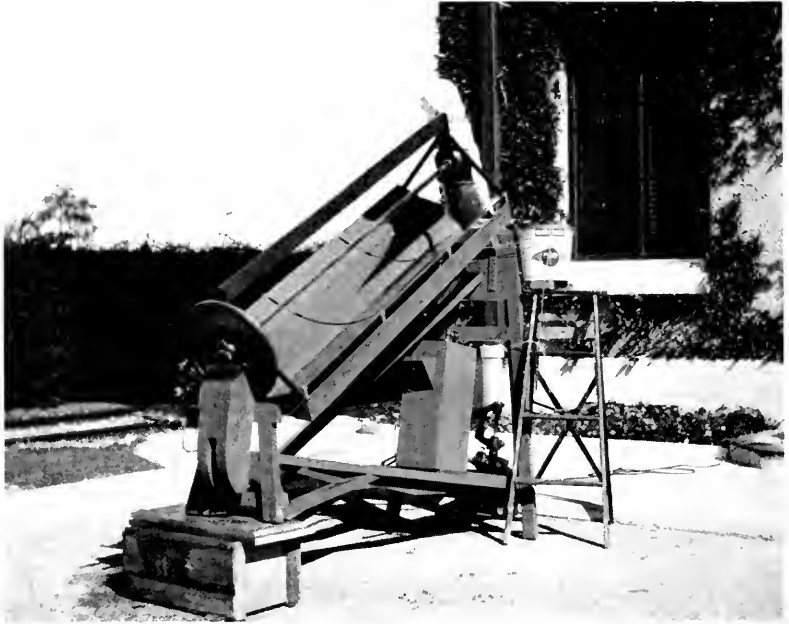

1. SOLAR FLASH BOILER  $\frac{1}{5}$  HORSEPOWER CAPACITY AS USED IN FLORIDA 1938

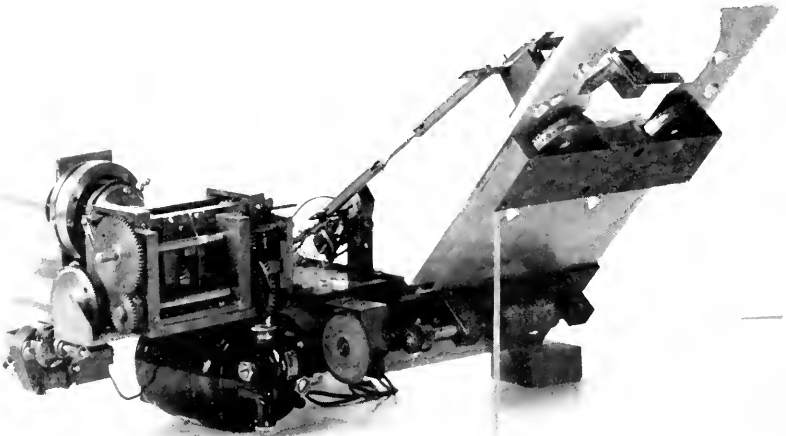

2. DRIVING MECHANISM FOR THE MIRROR AND WATER INJECTOR FOR THE SOLAR FLASH BOILER

## EFFICIENCY OF SOLAR FLASH BOILER

Regarding the efficiency of conversion of solar energy into mechanical power by the flash boiler, the following computations are pertinent :

*Efficiency of Solar Flash Boiler*

- A. Efficiency of the boiler, assumed temperature  $190^{\circ}$  C.:
- |  |    |         |
|--|----|---------|
| Mirror reflection .....  | 82 | percent |
| Transmission by vacuum jacket.....                                   | 85 | "       |
| Absorption by boiler tube.....                                       | 95 | "       |
| Loss of heat through the jacket.....                                 | 10 | "       |
| Boiler efficiency $0.82 \times 0.85 \times 0.95 \times 0.90 =$ ..... | 60 | "       |
- B. Thermodynamic factor for perfect engine:
- |  |                 |
|--|-----------------|
| Assumed temperature of condenser.....  | $30^{\circ}$ C. |
| Efficiency factor $\frac{190^{\circ} - 30^{\circ}}{190^{\circ} + 273^{\circ}}$ ..... | 34.5 percent    |
- C. Mechanical efficiency of engine is assumed to be 75 percent.
- D. Final result. Efficiency of conversion of solar to mechanical energy:
- |  |              |
|--|--------------|
| Factor = $0.60 \times 0.345 \times 0.75 =$ ..... | 15.5 percent |
|--|--------------|

## COMPETITION OF SOLAR POWER AGAINST COAL, OIL, AND WATER POWER

In the experiments of most earlier inventors, the protection of the boiler tube by a vacuum jacket was not practicable, the cheap but accurate construction of the mirror to give high reflection with permanency was not feasible, and the simplest arrangement to follow the sun was not generally made use of. Consequently, the cost was up and the efficiency was down. Hence these earlier devices were quite unable to compete with power from coal or water under most conditions. With the high efficiency and great simplicity of the present flash boiler scheme, I compute that power can be had from the sun at not exceeding 0.5 cent per horsepower-hour, and still give a good return on the investment.

## WILLSIE AND BOYLE EXPERIMENTS

I wish, however, to refer to one of the earlier inventions in which efficiency was sacrificed for cheapness. It was that of Willsie and Boyle who installed a solar power plant at Needles, Ariz., about 1910. Their scheme comprised a large, shallow black-bottomed pond wherein the water attained temperatures considerably below the boiling point. This heat they used to drive a sulphur dioxide engine, cooled by the evaporation of water. They claimed that their device was able to compete with coal in that locality, although both its boiler efficiency and its thermodynamic efficiency were low. It appears not to have come into much commercial use, however.

## STORAGE OF SOLAR HEAT OR POWER

I will now consider briefly some suggestions relating to the storage of heat or of power from the sun. As everyone knows, heat is prone to dissipate itself. There are no insulators against heat conduction comparable in efficiency to those which prevent the flow of electricity. My friend Dr. Cottrell, however, proposed to me a scheme which may be worth a trial. He suggests a silo-shaped, cement-lined pit in the ground, filled nearly to the top with dry coarse sand, and roofed over. Above the sand lies a layer of perhaps 10 feet of glass wool, such as is used for roof insulation. A pipe leading from the solar heater to the center of the upper surface of the sand has an appropriate network of branch pipes covering the surface. A similar network at the bottom of the pile leads to an outlet pipe, and thence back to the heater. An automatic pump which runs only while the focus tube is hot, draws hot air through the solar heater into the top of the sand. Owing to the notoriously bad conductivity of dry sand, and the high degree of protection from upward convection and conduction offered by the thick layer of glass wool, the sand pile receives the heat, and keeps it in a horizontal layer. The heated layer gradually works down, till, if the storage operation is very long-continued, the whole sand pile becomes of nearly as high temperature as the air in the focus tube itself. With a sand silo of sufficient capacity, Dr. Cottrell thinks the efficiency would be so high that when the heat was drawn away, perhaps months later, by reversing the circulation of air, the air would come away from the top of the sand very nearly as hot as it formerly entered. No one has tried this interesting scheme, but it would be desirable to do so. Should it succeed, it might show the way to use the heat of summer to warm one's house in winter.

Electric storage batteries are so well known that it is unnecessary to point out that solar power may be conserved thereby for night use. It is the cost which shades this proposal.

Chemical storage might be done by electrolyzing water, and saving the hydrogen to be burned in air with boilers to generate steam. This involves the problem of successful use of hydrogen as a steaming fuel.

Mechanical storage could be accomplished by pumping water to a high level reservoir, to be used in a hydroelectric plant later. This also looks costly, and difficult except in hilly country.

Possibly best of all would be a heat storage within a pressure tank filled with water, and surrounded by a thick envelope of glass wool. The water, heated far above the boiling point, would supply steam for hours of cloudiness or night.

## COMMERCIAL USE AND COST OF SOLAR HEATING

It is probable that so long as coal is cheap and abundant there will be no extensive use of solar power. However, small installations, in 2- to 5-horsepower units, may become profitable under favorable conditions. Solar heat has already been used successfully for refrigeration, and possibly might be combined with a heating system for conditioning the air in ranch propositions in cloudless regions. The classic use of solar power is, of course, for irrigation, and here, as remarked above, the problem of storage is not important. It is conceivable that great reservoirs might be pumped full of water from rivers or lakes by solar power in dry years to irrigate land when rains fail.

As remarked above, both solar cooking and solar distilling of non-potable water are practical and efficient propositions, which it is likely will be in common use before very long if the necessary outfits can be produced at attractive prices. The cost of solar devices, as of all other products, depends greatly on the volume of sales. These devices, however, as compared with automobiles are extremely simple. Though it might cost prohibitively to produce them singly, I think not if produced in thousands.



SMITHSONIAN MISCELLANEOUS COLLECTIONS  
VOLUME 98, NUMBER 6

DECAPOD AND OTHER CRUSTACEA  
COLLECTED ON THE PRESIDENTIAL  
CRUISE OF 1938

(WITH INTRODUCTION AND STATION DATA)

(WITH THREE PLATES)

BY

WALDO L. SCHMITT

Curator, Division of Marine Invertebrates,  
U. S. National Museum

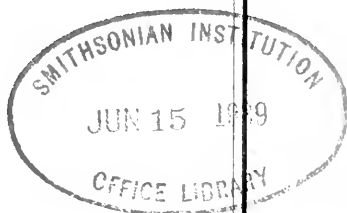

(PUBLICATION 3531)

CITY OF WASHINGTON  
PUBLISHED BY THE SMITHSONIAN INSTITUTION  
JUNE 15, 1939





SMITHSONIAN MISCELLANEOUS COLLECTIONS

VOLUME 98, NUMBER 6

DECAPOD AND OTHER CRUSTACEA  
COLLECTED ON THE PRESIDENTIAL  
CRUISE OF 1938

(WITH INTRODUCTION AND STATION DATA)

(WITH THREE PLATES)

BY

WALDO L. SCHMITT

Curator, Division of Marine Invertebrates,  
U. S. National Museum



(PUBLICATION 3531)

CITY OF WASHINGTON  
PUBLISHED BY THE SMITHSONIAN INSTITUTION  
JUNE 15, 1939

The Lord Baltimore Press  
BALTIMORE, MD., U. S. A.

# DECAPOD AND OTHER CRUSTACEA COLLECTED ON THE PRESIDENTIAL CRUISE OF 1938

(WITH INTRODUCTION AND STATION DATA<sup>1</sup>)

By WALDO L. SCHMITT

*Curator, Division of Marine Invertebrates, U. S. National Museum*

(WITH THREE PLATES)

## INTRODUCTION

In July and August of 1938 the President of the United States, the Honorable Franklin D. Roosevelt, undertook an inspection cruise and fishing expedition from San Diego, Calif., to Pensacola, Fla., by way of the Panama Canal aboard the U.S.S. *Houston*. The Smithsonian Institution was honored with an invitation to participate, and it was a great privilege and my good fortune to be the Naturalist selected to accompany the expedition.

The cruise, which began on July 16 and ended on August 9, covered a total of 5,888 miles in the brief space of 24 days, during which 14 different collecting stops were made. These were distributed among the possessions of five different nations: Mexico (Lower California and Socorro Island), France (Clipperton Island), Ecuador (the Galápagos Islands), Costa Rica (Cocos Island), and Colombia (Old Providence Island in the Caribbean). No collecting was done in the Canal Zone or in the Republic of Panama.

All manner of collecting was undertaken, fishing, bird hunting, and botanizing, dredging, tide-pool and shore collecting—indeed, all kinds of endeavor that might yield something of interest to the Smithsonian Institution and our National Collections. The ichthyological collection, which perhaps took first place in the President's interest, is one of the most important that has ever come to the United States National Museum from that section of the Pacific.

In obtaining fish as scientific specimens, as well as for sport, the President was ably assisted by members of his personal party: Mr.

---

<sup>1</sup> For additional notes and illustrations, see "The Presidential Cruise of 1938" *in*: Explorations and Field-work of the Smithsonian Institution in 1938, pp. 1-14, 1939.

Stephen Early, Mr. Frederick B. Adams,<sup>2</sup> Mr. Basil O'Connor, Capt. Daniel J. Callaghan, U.S.N.,<sup>3</sup> Col. Edwin M. Watson, U.S.A., and several of the officers of the *Houston*. Other specimens were taken by the crew with hand lines over the ship's side or were picked up ashore.

It is not possible to make adequate acknowledgment to all aboard the *Houston* who contributed in one way or another to make the expedition an unqualified success, from the Captain and Wardroom down through the whole ship's company. There are many more among the ship's officers and personnel to whom I am much indebted for many kindnesses and much real and helpful assistance than I am permitted to mention in this limited account. I should like to call them all by name. Jack Barron was detailed as my assistant, and I am grateful to Captain Barker for assigning so fine a seaman to me, and to Barron for all the helpful services that he rendered me. R. B. Thompson, of the paymaster's clerical force, an experienced amateur photographer, was kind enough to assist me in taking pictures, with the result that I am indebted to him for most of the photographs that I brought back to the Institution from the cruise. Unique among the photographs which he took are three of leaping porpoises, taken off Hood Island on July 28.

Under Lieutenant Commander Kelly's able direction, we made our successful landing on Clipperton. To Captain Barker and to his executive officer, Commander Bailey, in particular, all thanks are due for the wonderful cooperation extended me on all occasions throughout the cruise.

The scientific results of the Presidential Cruise have proved to be of extreme interest. Not only have a number of new records of occurrence been established and hitherto unrepresented species been added to the Museum's collections, but more than 30 new species, subspecies, and varieties have been discovered. These will be described in a series of scientific papers which are to follow.

The fact that the collections in the Galápagos were made at a time of the year when these islands have seldom been visited by investigators adds materially to their scientific interest and value. Likewise, the avifauna of Clipperton Island, not heretofore represented in the Museum collections, has now become well known to us.

---

<sup>2</sup> Mr. Adams took a number of very worth-while color photographs for the purpose of recording the color of the fresh specimens as they were landed in the fishing boats. These he has very generously contributed to the collections of the Smithsonian Institution.

<sup>3</sup> I am indebted to Captain Callaghan for a number of notes.

In looking over the material brought back, one cannot help being imbued with an enthusiastic appreciation of the President as a man of broad biological interests and a generous patron of science. Throughout the cruise he took an active part and a live interest in all our collecting.

## STATION DATA

## LOWER CALIFORNIA, MEXICO

- | Station<br>No. |   |
|----------------|---|
| 1-38.          | July 17. Cedros Island. Shore collecting, both north and south of cannery east side of island. Amphipods and earthworms from under drifted kelp on gravel beach to north. Crabs from shore and "cliffs," and fossils from fallen portion of cliff to south. |
| 2-38.          | July 17. Cedros Island. Bottom sample in 24-25 fathoms, about $\frac{1}{4}$ way from shore to anchorage.  |
| 3-38.          | July 18. Magdalena Bay. Dredging, boat dredge. Inside northern point of entrance to bay, between Belcher Point and anchorage, 10-15 fathoms, sandy, weedy bottom, myriads of amphipods.   |
| 4-38.          | July 18. Magdalena Bay; filamentous green algae from deeper end of preceding dredge hauls.  |
| 5-38.          | July 19. Cape San Lucas. Dredging, boat dredge, 6-10 fathoms, off Punta Gorda, off rocky shore to west end San Jose del Cabo Bay.   |
| 5a-38.         | July 19. At anchorage, San Jose del Cabo, alcyonarian from anchor; depth 48 fathoms.  |

## SOCORRO ISLAND, MEXICO

- |       |  |
|-------|--|
| 6-38. | July 20. Shore collecting, Braithwaite Bay, at "landing place."  |
| 7-38. | July 20. Collecting up on land back of beach; soil put through Berlese funnel. Also scorpion, spiders, and a crab found under rock.                                    |
| 8-38. | July 20. Dredging, boat dredge, two hauls, 7-8 fathoms, on sandy bottom, from off landing beach toward rocky point forming east side of cove where landing is located. |

- CLIPPERTON ISLAND (now a French possession)
- Station No.      CLIPPERTON ISLAND (now a French possession)
- 9-38. July 21. Shore collecting at Clipperton on rocks to south of landing place.
- 10-38. July 21. Bucket of algae from Clipperton lagoon, back of landing.
- 11-38. July 21. Piece of Clipperton Rock.
- 12-38. July 21. Muck from anchor chain. Was coated with this material; looked like old waste; depth 72 fathoms.
- 13-38. July 21. Two specimens blue trigger fish caught by President.
- 14-38. July 21. Debris from two boobies' nests on lagoon shore back of landing.

GALÁPAGOS ISLANDS, ECUADOR

- 15-38. July 24. Sullivan Bay, James Island. Shore and tide-pool collecting 3:30 to 5:00 p. m., tide beginning to run out.
- 16-38. July 25. Narborough Island. Shore collecting.
- 17-38. July 25. At anchorage off Tagus Cove, Albemarle Island. With electric light off gangway 11:00 p. m., dip-net.
- 18-38. July 26. At anchorage off Tagus Cove. From anchor chain, 10 a. m.; depth 50 fathoms.
- 19-38. July 26. Elizabeth Bay, Albemarle Island; landed in bay at south end of black beach north of mangroves, north of two "red" islands.
- 19a-38. July 26. Locality as for No. 19-38. Nest material of old flightless cormorant nest.
- 20-38. July 26. Locality as for No. 19-38. Taken off anchor chain; depth 24 fathoms.
- 21-38. July 27. Crew ashore at Post Office Bay, Charles Island; collected various things; also specimens of all plants seen in flower on road to Wittmer's place.
- 22-38. July 27. At anchorage off Gardner Bay, Hood Island. With electric light off gangway, 11:00 p. m., dip-net.
- 23-38. July 29. South Seymour Island, plateau-land section of island. Odds and ends picked up on beach and shore; sand sample, and sand washings.

- Station  
No.
- 23a-38. July 29. South Seymour Island anchorage. With electric light from gangway, 11:00 p. m., dip-net.
- 24-38. July 30. James Bay, James Island. Bottom sample in about 24 fathoms.
- 25-38. July 30. Locality as for No. 24-38. Two octopi from rocks along shore.
- 25a-38. July 30. Mud and water sample from flamingo lagoon, James Bay, James Island.

## COCOS ISLAND, COSTA RICA

Aug. 1. Inland at Wafer Bay for rare palm; all day hike.

Aug. 2. Ashore in a. m. at Wafer Bay, south side, for tree ferns; p. m. at Chatham Bay.

Aug. 3. Forenoon in fishing boat with Messrs. Adams and Early for sailfish photos.

26-38. Aug. 3. Parasites from 116-pound sailfish; forenoon.

27-38. Aug. 3. Copepod found in dish in which two sucker fish from sailfish were killed in alcohol.

28-38. Aug. 3. At Chatham Bay anchorage. Bottom sample, mostly sand; depth 30 fathoms.

29-38. Aug. 3. Several dredge hauls off Chatham Bay.

## OLD PROVIDENCE ISLAND, COLOMBIA (in the Caribbean)

30-38. Aug. 6. Shore, reef, and tide-pool collecting in early afternoon.

30a-38. Aug. 6. Bottom sample, at anchorage, in 8 fathoms.

31-38. Aug. 6. Dredge haul in about 7-8 fathoms, inside reef, Catalina Harbor.





#### DECAPOD AND OTHER CRUSTACEA<sup>4</sup>

The crustacean collection, though not large, contains several novelties: a new species, *Thalamita roosevelti*; and two new subspecies, *Callinidca lacvicauda occidentalis* and *Crangon hawaiiensis clippertoni*. A West Indian species, *Callinassa hartmeyeri*, earlier reported by Hult (Arkiv Zool., vol. 30A, No. 5, p. 7, text figs. 1-4, pl. 1, figs. 1a, 1b, 1938) from the Galápagos, was found at Socorro Island. *Brachycarpus biunguiculatus*, another West Indian species, originally described from Bermuda and well known in the Mediterranean, with also a single record from the Red Sea, rather surprisingly turned up in the Clipperton Island material, a first truly Pacific record, for this species. An *Ogyrides*, the first representative of the genus from the west coast of America which was taken at Punta Gorda, as well as a *Crangon* from Socorro, a possible new variety of *Crangon paracrinitus* from Clipperton, and several species of *Petrolisthes*, have not been described for want of adequate material of each of them. Otherwise, there is a small residuum of very fragmentary specimens, juveniles, and larval forms, not satisfactorily determinable, that are not included in this report.

In this list we are able to enumerate approximately 100 different decapods, including 4 species of porcellanid or flat crabs; in addition, there is 1 leptostracan, a barnacle, and 8 species of copepods, making a total of 110 different kinds of Crustacea. The greatest number of species listed for any one station was 42 from Old Providence; next in order, 17 from Sullivan Bay, James Island, Galápagos.

Of the new forms described in this paper, two were collected at Clipperton Island, where, so far as I have been able to ascertain, little or no marine carcinological collecting has ever been done before. This coral atoll, which is unique in American waters, supports a remarkably interesting marine fauna, inasmuch as 7 of the 18 specifically identified species have strong Indo-Pacific ties, and 1, *Brachycarpus biunguiculatus*, a less strong tie. Indeed, four of those seven species are identical with species known from Hawaii and beyond.

---

<sup>4</sup>The amphipods and isopods will appear as separate reports by Clarence R. Shoemaker and J. O. Maloney, respectively, of the Division of Marine Invertebrates, U. S. National Museum.

## SPECIFICALLY DETERMINED CLIPPERTON ISLAND DECAPODS

Indo-Pacific species	Species with Indo-Pacific ties	West American species
<i>Crangon pacificus</i>	<i>Crangon hawaiiensis clippertoni</i>	<i>Synalpheus nobili</i>
<i>Lysmata paucidens</i>	<i>Crangon paracrinitus</i> variety	<i>Pomagnathus corallinus</i>
<i>Pachygrapsus minutus</i>	<i>Brachycarpus biunguiculatus</i>	<i>Callinassa hartmeyeri</i>
<i>Percnon abbreviatum</i>	<i>Thalamita roosevelti</i>	<i>Petrolisthes marginatus</i>
		<i>Pachycheles biocellatus</i>
		<i>Gecarcinus planatus</i>
		<i>Platypodia rotundata</i>
		<i>Actea dorii</i>
		<i>Actea sulcata</i>
		<i>Micropanope xantusii</i>
		<i>Telcophrys cristulipes</i>

In keeping with the presence of the South Pacific genus of skink, *Emolis*, on Clipperton, where this genus is represented by *E. arundelii* (Garman), is our discovery of (1) the first New World *Thalamita*, (2) a new species of terrestrial amphipod (see footnote 4, p. 7) not far removed specifically from *Orchestia marquesana* Stephensen, of the Marquesas Islands, Oceanica, and (3) the littoral crab, *Pachygrapsus minutus* Milne-Edwards, originally described from New Caledonia.

In order to avoid needless repetition of station data, the species, together with pertinent remarks and descriptions of the new forms, have been listed in systematic order under the several localities at which they were taken.

I am greatly indebted to Dr. Mary J. Rathbun, Associate in Zoology, United States National Museum, Smithsonian Institution, for assistance in naming the brachyuran Crustacea; and to Steve A. Glassell, of Beverly Hills, Calif., for the identification of the representatives of the porcellanid genera *Petrolisthes* and *Pachycheles*, as well as of the pinnotherid crab, *Pinnarodes*. Dr. C. B. Wilson, of Westfield, Mass., determined the free-swimming and parasitic copepods collected. A single leptostracan, *Nebalia bipes* (Fabricius), was sorted from the Magdalena Bay dredgings.

I shall always be grateful to President Roosevelt for the wonderful opportunity he afforded me for gathering the scientific material reported in the series of papers of which this is one.

## ANNOTATED LIST OF THE CRUSTACEA

**Cedros Island**, Lower California, Mexico, July 17 (sta. 1-38); shore collecting, both north and south of cannery east side of island.  
*Pachygrapsus crassipes* Randall. . . . . 44♂ 37♀ (11 ovig.)

**Magdalena Bay**, Lower California, Mexico, July 18 (sta. 3-38) ; boat dredge inside northern point of entrance to bay, between Belcher Point and anchorage, 10-15 fathoms, sandy, weedy bottom, myriads of amphipods.

*Lepeophtheirus dissimulatus* Wilson.....12♀

These parasitic copepods were not taken in the dredge, but were picked off a broom-tailed grouper, *Mycteroperca xenarcha* Jordan, taken in the Bay by the fishing parties.

*Nebalia bipes* (Fabricius).....1

*Penaeopsis mineri* Burkenroad.....1♂ 1♀

*Periclimenes (Ancyllocaris) holmesi* Nobili.....2

*Pleuroncodes planipes* Stimpson.....3

These are fragmentary specimens regurgitated by a large black sea bass caught in bay.

*Paguristes* species.....1♀ ovig.

*Microphrys branchialis* Rathbun.....1♂ 1 juv.

*Cancer antennarius* Stimpson.....1♀ juv.

**Cape San Lucas**, Lower California, Mexico, July 19 (sta. 5-38) ; boat dredge, 6-10 fathoms, off Punta Gorda, off rocky shore to west end San Jose del Cabo Bay.

*Lepeophtheirus dissimulatus* Wilson.....5♀

One of these five specimens was found in our dredged material; the other four were picked from the external surface and nostrils of a large gulf grouper, *Mycteroperca jordani* (Jenkins and Evermann), taken by the fishing parties this day.

*Ogyrides* species.....1

The first of the genus to be reported from the west coast of America. Though very probably a new species, the material at hand does not suffice for a description.

*Periclimenes (Ancyllocaris) holmesi* Nobili.....3

*Arenaeus mexicanus* (Gerstaecker).....1♂ 1♀

*Pliosoma parvifrons* Stimpson.....4♂ 1♀ 1 juv.

**South of Cape San Lucas**, Lower California, approximately lat. 20° 53' N., long. 110° 14' W., 11 p. m., July 19, from port condenser tubes of the *Houston*.

*Pleuroncodes planipes* Stimpson.....50±

About 11:00 o'clock at night, Lt. H. K. Gates, one of the engineer officers, called me to the engine room to see a lot of bright red shrimp they had discovered in the suction side of one of the condensers opened for minor repairs. They proved to be the galatheid shrimp, *P. planipes*, very common in Lower California waters at certain seasons. At times they occur in such countless numbers that they color the water red for great distances. Huge windrows of the dead shells of these animals have been observed in the past as conspicuous red streaks along the shore line. Crustaceans of this type form an important whale food and without doubt this species played an important part in the former abundance of whales in the Lower Californian and Mexican waters. As noted above, a large black sea bass taken in Magdalena Bay during the day regurgitated several of these galatheids when hauled into the boat.

**Socorro Island, Mexico, July 20 (sta. 6-38), shore collecting, Braithwaite Bay, at landing place.**

*Crangon* species .....1

**CALLIANIDEA LAEVICAUDA OCCIDENTALIS, n. subsp.**

*Holotype*.—An ovigerous female (U.S.N.M. no. 77788) about 48 mm. long from rostral projection to end of telson, accompanied by a male approximately 35 mm. long and a very small male, perhaps juvenile, 18 mm. long. The upper margin of hand from posterior extremity to tip of movable finger measures about 17 mm. in the holotype and 13 mm. in the larger of the male specimens.

*Description*.—About 10 years ago I determined two specimens of *Callianidea laevicauda* from the Tres Marias Islands, Mexico, for Señor Carlos Stansch, at that time an agent of the Dirección Forestal y de Caza y Pesca of Mexico. In those specimens, as in these from Socorro, most, if not all, of the pleopod filaments are two-jointed. Moreover, Pacific specimens of *C. laevicauda* have the greater part of the length of the lower margin of the large chela more or less toothed or tuberculate and the ridge on the inner side of the fixed finger crenulate. Atlantic specimens which I have examined from Puerto Rico, Culebra, Barbados, and Curaçao have the lower margin of the large chela only very slightly roughened or, at most, obscurely crenulate at about midlength only, whereas the ridge on the inner side of the fixed finger is smooth. Otherwise, there seems to be little difference between the two forms, and such differences as I have

observed are no more than of subspecific rank. More material from both coasts of America is much to be desired. It is probable that Lockington's record of three specimens of *C. typha* from La Paz in the Gulf of California is based upon specimens identical with those from the Tres Marias Islands and Socorro.

<i>Petrolisthes</i> near <i>cinctipes</i> Stimpson.....	1♂
<i>Calcinus obscurus</i> Stimpson.....	3
<i>Coenobita compressus</i> Guérin.....	1
<i>Grapsus grapsus</i> (Linnaeus).....	1♂
<i>Leptodius cooksoni</i> Miers.....	1♀
<i>Ozius perlatus</i> Stimpson.....	1♂ 3♀

**Socorro Island**, Mexico, July 20 (sta. 7-38) on land, back of beach under rock.

<i>Gecarcinus planatus</i> Stimpson.....	1
--	---

**Socorro Island**, Mexico, July 20 (sta. 8-38), boat dredge, two hauls, 7-8 fathoms, sandy bottom, from off landing beach toward rocky point forming east side of cove where landing is located.

Callianassid .....	1 fragment
<i>Clibanarius panamensis</i> Stimpson.....	1

**Clipperton Island** (French possession), July 21 (sta. 9-38), shore collecting at Clipperton on rocks to south of landing place (on north-eastern shore of atoll).

#### CRANGON HAWAIIENSIS CLIPPERTONI, n. subsp.

*Holotype*.—Largest of eight specimens, a female approximately 13 mm. long, upper margin of palm of large hand 4.4 mm., chela, over all, 5.6 mm. (U.S.N.M. no. 77789).

*Description*.—This apparently new form differs but slightly from the description and figures given by Edmondson for his *C. hawaiiensis* (Bull. Bishop Mus., No. 27, p. 14, fig. 2, 1925); so slightly, indeed, that I asked Dr. Edmondson to reexamine his unique type in the light of the differences that I did discover.

In our Clipperton Island type and the specimens accompanying it the inner side or surface of the larger chela is smooth, as in the species proper; the outer side also appears smooth on casual inspection, but when excess moisture is removed, the presence of two not very conspicuous longitudinal grooves is revealed on the outer face

of the chela. The larger and deeper of these two inconspicuous grooves runs back from the articulation of the movable finger; the other, a little below the articulation, is shorter than the larger groove. The tip of the rostrum extends very little or scarcely in front of a line joining the anterior margins of the orbital hoods.

Dr. Edmondson writes me that he is unable to find any evidence of these longitudinal grooves on the outer side of the palm, and that the rostrum of his *C. hawaiiensis* is even longer and sharper than indicated in his figure, that it extends to a greater distance beyond the orbital hoods than is shown in the figure, and that the terminal portion of the rostrum is very narrow.

The specimens we have are certainly distinctively different from *C. hawaiiensis* on the basis of the character of the larger chela and the rostral length alone. Therefore, in spite of the close agreement between our specimens and the type of the species in almost all other points, I venture to refer to them as the Clipperton Island subspecies of Edmondson's species.

*Crangon paracrinitus* Miers variety.....4

These four specimens seem to bridge the differences existing between the species proper and its known variety *bengalensis* Coutière. As in that variety, our specimens lack the spine with which the minor chela of the type is armed. On the other hand, the proportions of the carpal joints of the second legs are more like those of the typical specimens than those of the varietal form. The rostrum of our specimens is small, there are no orbital grooves, and the hands and carapace are smooth. I do not feel justified at this time in giving these variants of *C. paracrinitus* a name.

*Crangon pacificus* (Dana).....2

*Crangon* species .....2

*Synalpheus nobili* Coutière.....28 (9 ovig.)

These specimens were of a brown-red color with darker transverse bands across the abdomen.

*Pomagnathus corallinus* Chace.....2

*Lysmata paucidens* Rathbun.....32 (3 ovig.)

This species was originally described from the Hawaiian Islands (Rathbun, Bull. U. S. Fish Comm. for 1903, vol. 23, pt. 3, p. 913, pl. 24, fig. 4 (1906)) and is common about Oahu and other islands and shoals in the Hawaiian area.

Nearly all of our specimens have four dorsal rostral teeth, of which two, usually, were on the carapace and two on the rostrum proper; one specimen had five teeth above; and one with an unusually short and certainly abnormal rostrum had only three teeth above; below there is mostly but a single tooth, sometimes two.

Outer antennular flagellum has 7-11 (usually 8-9) free joints and 5-7 fused, the free portion is longer than the fused, except in very young and small specimens.

The multiarticulate carpus of the second pair of legs may have from 20-25 articulations.

As compared with *L. galapagensis* Schmitt, *L. paucidens* has fewer dorsal rostral teeth, and a relatively longer rostrum which is normally longer than the eyes by that portion which lies anterior to the ventral tooth and which reaches about or even beyond the middle of the second joint of the antennular peduncle. The first pair of legs, the chelipeds, are relatively more slender, the second pair noticeably longer; and there are consistently more joints to the free portion of the outer antennular flagellum. The ambulatory legs and the body habitus of the two species are very much alike.

*Brachycarpus biunguiculatus* (Lucas).....1♀

Kemp (Rec. Indian Mus., vol. 27, pt. 4, p. 312, 1925) has discussed this species and given rather full synonymy. He very probably correctly regards Nobili's *B. advena* from the Red Sea (Ann. Sci. Nat., Zool. (9), vol. 4, p. 75, pl. 4, fig. 1, 1906) as a synonym of *B. biunguiculatus*.

It was somewhat of a surprise to find a single small female of *B. biunguiculatus* about 20.3 mm. in length among the Crustacea collected at Clipperton. In fact, it was not until a drawing of the telson was completed that it was suspected that we were dealing with a *Brachycarpus* at all. In most, if not all, particulars our specimen seems to fit the characterization of the species as set forth by Kemp, except in the number of segments in the fused basal portion of the outer antennular flagellum, which appears to have but seven segments. Kemp gives a range of from 15 to 23 segments in specimens which he examined, which included some from the West Indies. I examined our West Indian and Bermuda specimens and found that the larger specimens, both male and female, from Bermuda, Puerto Rico, and Barbados, upward of 40 mm. in length, had 15 to 21 segments in the fused basal portion of the outer flagellum, and about the same number in the thicker, free portion. On the other hand, the small specimens, mostly from 25 to 27 mm. in length (one 39 mm.),

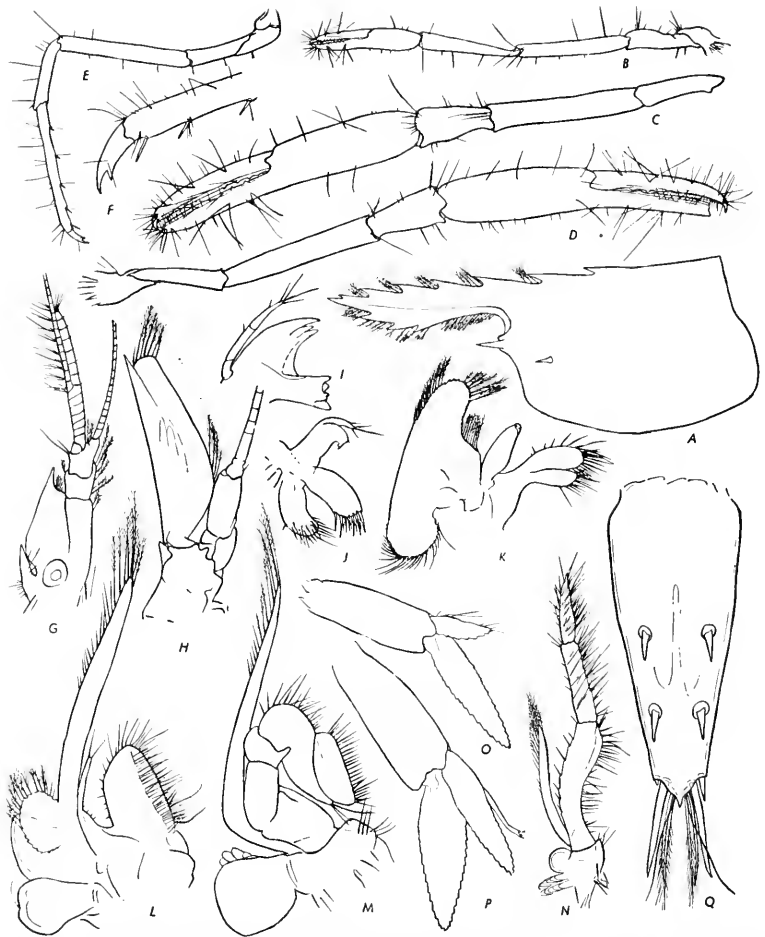

FIG. 1.—*Brachycarpus bimaculatus*, female. A, Lateral view of carapace and rostrum  $\times 6$ ; B, first leg  $\times 6$ ; C, left second leg  $\times 6$ ; D, right second leg  $\times 6$ ; E, third leg  $\times 6$ ; F, same, dactyl  $\times 16$ ; G, antennule  $\times 7$ ; H, antennal peduncle and scale  $\times 7$ ; I, mandible  $\times 15$ ; J, maxillule  $\times 15$ ; K, maxilla  $\times 15$ , the tip of the endopodite appears roughened, perhaps only kinked or slightly damaged; L, M, N, first, second, and third maxillipeds  $\times 15$ ; O, P, first and second left pleopods  $\times 15$ ; Q, telson  $\times 15$ . (The magnifications are approximate.)



from Barbados, off Jamaica, and Puerto Rico, had 8, 9, or 10 fused segments and from 10 to 13 free segments.

I do not find any characters that would indicate that the small specimens are other than *B. biunguiculatus*, although several of them are ovigerous. I have seen no small specimens with the segment count of the fully developed large ones, and therefore believe that this species varies considerably in the segmentation of the fused and thicker free portion of its outer antennular flagellum.

The rostrum of our Clipperton Island specimen has  $\frac{7}{3}$  teeth, of which the first two dorsal teeth are on the carapace, the next two are above the ocular peduncle, the last three are anterior to the eye; the anteriormost is very close to the tip of the rostrum; the ventral teeth are about as strong as the dorsal; the proximal tooth is placed just proximal to the anterior margin of the cornea, not beyond or anterior to it. The rostrum is slightly longer than the antennular peduncle and slightly shorter than the antennal scale.

The outer anterior angle of the basal joint of the antennular peduncle is armed with a well-developed spine, the tip of which exceeds the second joint of the peduncle. The spine of the antennal scale reaches to the end of the sixth article for the fused part of the outer antennular flagellum, the anterior margin of the blade to the end of the fifth article. The free portion of the shorter ramus of the outer antennular flagellum is a little longer than the fused portion; each appears to be composed of about seven articles.

On the anterior margin of the carapace the antennal spine projects well in front of the suborbital projection or angle; the hepatic spine is placed not much below the level of the antennal spine and is less than the length of that spine behind the anterior margin of the carapace; the hepatic spine is also less than half the size of the antennal spine.

The right second chela is very slightly larger than the left; it exceeds the antennal scale by the entire propodus. The fingers of either chela of this pair are slightly shorter than the corresponding palm or merus; the carpal joints are a little more than half the length of the corresponding palms.

*Callianassa hartmeyeri* Schmitt.....1♂ 1♀

Our specimens agree with those figured and described by Hult (Arkiv Zool., vol. 30A, No. 5, p. 7, figs. 1-4, pl. 1, 1938). On the chelae of these specimens there were bright ochraceous to orange ochraceous (Ridgway) irregular color markings; both fingers toward

their distal china-white tips were of this golden yellowish brown, the palms showed an irregular pattern of color and the upper surfaces of carpus and merus were likewise suffused with it, the color being more concentrated and stronger on the merus than on the carpus. It struck me as a bit unusual that burrowing shrimps such as these, so often referred to as ghost shrimps, should show any particular color markings at all other than very light shades of blues, pinks, or very light flesh color.

*Petrolishes marginatus* Stimpson.....21

*Pachycheles biocellatus* (Lockington).....19

**THALAMITA ROOSEVELTI, n. sp. 2♂ 1♀**

Fig. 2

*Holotype*.—A male (U.S.N.M. no. 77787), the largest of three specimens, measures 19.6 mm. in greatest width across the tips of the



FIG. 2.—*Thalamita roosevelti*, male. *A*, Dorsal view of carapace  $\times 2$ ; *B*, outer face of right chela and carpus  $\times 2$ ; *C*, basal joint of antenna  $\times 4$ ; *D*, distal segments of abdomen  $\times 2$ . (The magnifications are approximate.)

fifth pair of lateral spines marking the posterolateral angle of the carapace, and 13.4 mm. long from the posterior margin to the anterior border of the median lobes of the front. The movable fingers of either chela are approximately of the same length, about 7 mm. each; the left hand a shade less than 5 mm. in dorsal length of palm, the right one just about 5 mm. long. The left palm is also a little, but not very noticeably, stouter than the right.

The other two known specimens of the species are both immature, a male and a female of approximately the same size and measuring about 11.2 mm. in greatest width; the female is scarcely larger than the male.

*Description*.—*Thalamita roosevelti* is one of a group of three very closely related species, which includes *T. ulcocki* de Man (Abh. Senckenb. Ges., vol. 25, p. 646, 1902) and *T. gardineri* Borradaile (Fauna Maldives and Laccadive Archip., vol. 1, p. 205, fig. 36, 1902).

The length of the carapace is very nearly two-thirds its greatest width, the posterior margin just about a third. The transverse ridges or keels on the carapace are well defined and finely crenulate on their anterior margins; in number, position, ornamentation, and arrangement they are not unlike those of *T. gardineri* as figured by its author. I cannot make out from Borradaile's drawing whether the entire surface of the carapace is finely granulate, or whether just its dense pubescent investiture is indicated. Except for the keels and several small patches of granules, the carapace of *T. roosevelti* is covered with a short, thick pubescence that hides its surface. This was found to be smooth and finely punctate where the pubescence was scraped off with a needle. Just behind the bases of the adjacent portions of the median and submedian lobes of the front, and also toward the bases of the second and third lateral teeth of the carapace, there is a small scattering of granules which rise at least to the level of the top of the short pubescent covering of the carapace and are not at all obscured by it.

In both *T. gardineri* and *T. alcocki* the anterolateral margin is described as more oblique than in *T. cretastica* Alcock (Journ. Asiatic Soc. Bengal, vol. 48, p. 86, 1899), and so is it also in our species.

The median lobes of the front are separated by a distinct, narrowly U-shaped sinus which runs backward behind the level of the anterior margins of the submedian lobes as far as, or even a little farther than, the sinus either side of the median lobes which separates them from the submedian lobes. In *T. alcocki* the median sinus of the front runs back only to the level of the anterior margins of the submedian teeth, much as in *T. cretastica*; in *T. gardineri* this sinus is like that of *T. roosevelti* in depth. The median lobes are distally rounded off; the right one is a little wider than the left; in the front the median lobes are placed at a slightly lower level than the submedian lobes; these slightly yet definitely overlap the median lobes. In *T. gardineri* there is no overlapping of the median lobes by the submedians. The anterior margins of the submedian teeth, though lightly convex, are in general transverse, more so in the young, immature specimens than in the larger type specimen. In *T. alcocki* the anterior margin of the submedian lobes is said to be very straight and transverse. The outer lobes of the front above the antennae are separated from the submedian lobes by a sinus about the size and shape of the median sinus of the front, only a little deeper; the lobes of this outer pair are narrowly triangular, distally blunt.

Of the teeth of the anterolateral margin, the first (extraorbital) is the largest, though not quite the longest measured along its outer

margin; the second and third teeth are very much alike in size and shape, the third is slightly less stout than the second, both are more or less subequal in length of outer margin and both are longer than the first; the fourth tooth is the smallest, perhaps half the size of the third, but in no sense rudimentary; fifth not shorter than any of the others, but more slender, and so appearing rather long.

The lateral, as well as the frontal teeth of our species in relative size are very similar to the other two species with which it is compared.

The basal antennal joint is about as long as the orbit is wide. It is provided with a high, prominent crest, plainly visible in dorsal view. This crest, to all appearances, is fairly smooth and unarmed, but, on close inspection with considerable magnification, is seen to be slightly roughened or obsolescently nodulated with low, irregularly placed swellings of its upper margin, more to one side or the other than actually on the margin itself; the crest is neither denticulate nor spined, it might be called obscurely granulate, but it is more lumpy than granulate; either side of the crest, lower down, the surface of the joint is small tuberculate; these little, more or less low conical tubercles, are larger on the proximal end of the joint than distally. I am of the opinion, although I have seen no specimens of *T. alcocki*, that the crest of its basal antennal joint may be much like that of *T. roosevelti* here described. This crest in *T. gardineri*, as it is not contrasted with *excitastica* in Borradaile's remarks, must, by implication, be, as in that species, very plainly denticulate, for, as figured, it appears more or less saw-toothed.

Either hand of the nearly subequal chelae has a blunt squamose ridge on its inner face; the inner upper margin is armed with two stout spines, of which the posterior, arising behind middle of palm is larger, longer, and stronger, the anterior spine is a little behind the distal margin of the palm; on the outer margin of the upper surface of the palm is another strong spine about the size of the anterior one on the inner margin; on the outer margin, just behind the distal border of the palm, is a blunt, conical tubercle; there is another strong, stout, sharp spine on the palm at the carpal articulation, the fourth of those arming the chela; on the outer surface of the palm is a low, squamose ridge running from below this last mentioned spine to the articulation of the movable finger; below this ridge are two other better defined, crenulate ones; the upper one is the stronger, with larger crenulations, anteriorly it bends downward a little, to be continued on to the outer side of the fixed finger as a more or less smooth, noncrenulate carina; the crenulations of the lower ridge, as it runs on to the finger, become progressively smaller until they fade out, so that the

anterior third of that portion of the ridge traversing the finger is smooth. The under surface of the hand is smooth; between the ridges there are scattered granules and small squamiform tubercles and some slight pubescence; above the low, squamiform ridges either side of the palm and on its upper surface are a number of low, squamiform tubercles, more or less concealed by the thicker pubescence here, some are a little more conical than others and raised a little above the pubescence. The armature and ornamentation of the hands seems to be about as described for *T. alcocki* and, in general, not so very unlike the somewhat sketchy drawing of *T. gardineri*, although in the latter species, in place of the anterior conical tubercle on the outer margin of the upper surface of the palm, a spine as strong as the one behind it or opposed to it on the inner margin is shown.

The movable finger, measured in a chord from tip to the middorsal point of the anterior border of the palm, exceeds, by about  $2/7$  of its length, the dorsal length of the palm measured back from the same point. The two chelae are about of the same size and have their fingers more or less of the same length; the right movable finger is very slightly the shorter. De Man states that the fingers of *T. alcocki* are shorter than the palm; in *T. gardineri*, as drawn, the movable fingers, at least, in the given dorsal view are longer than the upper margin of the palm, while in the figure presenting the outer face of the chela the finger is shorter than the dorsal length of the palm; as this figure has been especially drawn to show the character of the chela, it undoubtedly portrays the correct relation of finger to palm.

The carpus of the cheliped has a long, strong spine at the inner angle about twice the length of the palmar spine at the carpal articulation. There is a curved crenulate line back of this spine; upper surface of carpus granulate or low tuberculate; there are three spines toward the outer side of the carpus, the inner of these is the sharper, the next or middle one the larger, more produced, and subacute, the outer one is blunter, low, and more or less conical, a low ridge runs back from the first and third of these spines; the ridge behind the first of the three spines is fine-crenulate, the other ridge behind the third spine is apparently finely and almost obscurely denticulate.

The merus of the cheliped has three spines on the anterior border, the distalmost is the larger and placed at a lower level than the others, the proximal the smallest; there are several small denticles or tuberculiform teeth before the proximal spine, one between it and the second spine, and two or three, little larger than granules, bunched between the second and third; the anterodistal angle of the merus forms a

flattened, roughly rounded lobe with denticulate or small tuberculate margin.

The posterior border of the propodus of the fifth or swimming leg is armed with spinules. As viewed from above there are four short, stout, acute spinules—one could well call them spines—on the right propodus this side of the close-set fringe of long hair that marks the anterior (upper) margin of the joint and a single one the other side, behind the fringe of hair, inserted proximal to the proximalmost of the four spinules dorsal to the fringe of hair; on the left propodus there are eight spinules above or dorsal to the fringe of hair and three behind, these three are inserted distal to the second of the spinules of the upper side; the first two spinules on the upper side of the fringe of hair on the left propodus are colorless, small, and relatively inconspicuous for that reason; the other spinules for the most part show more or less reddish color. In *T. alcocki* the hinder margin of the propodus of the fifth pair of legs is armed with 5 sharp spinules; in *T. gardineri* with 10.

*Color.*—Of the alcoholically preserved type: Granulations showing through the pubescence of the carapace, and the crenulations of the keels or ridges ornamenting it are reddish.

The movable finger of the chelae is white-tipped, followed by a brownish transverse band, then a white band of about the same width. Neither band is as wide as the white portion of the tip, and both together occupy about as much space as the reddish brown basal portion of the finger. The middle third of the fixed finger is brownish, distal and proximal thirds white.

The lateral spines of the carapace are red tipped and there is a fleck of the same color near the base on the outer margin of each of the lateral teeth except the fourth; behind the corresponding fleck on the fifth lateral spine there is a second spot of color farther down or posterior to the first fleck, a little more removed from that fleck than it is from the colored tip of the spine; the tubercles and granules of the chelipeds are also of a reddish color; the spines arming the hands are color-marked like the lateral spines. The ambulatory legs are dull blackish brown barred; there are two transverse bars of this dark color on the dactyl, a very wide one around the middle of the propodus, a similar one around the carpus, and two narrow ones about the merus.

*Remarks.*—From the species of *Thalamita* that fall within the purview of Alcock's group II.A (Journ. Asiatic Soc. Bengal, vol. 68, p. 73, 1899) ours is at once distinguished from *T. investigatoris* and *imparimanus*, and I believe also from *T. tenuipes*, by the fact that in these species the hinder margin of the propodus of the last pair, or

swimming pair, of legs is smooth, not armed with spinules. *T. exctastica* and most of its subspecies and varieties are also distinguished from our species by the absence of these propodal spinules which are, however, present in at least one variety of *exctastica*. All the *exctastica* forms differ from *T. roosevelti* and most if not all other *Thalamitis* in possessing a small accessory tooth or spine on the outer side of the first lateral, extraorbital tooth of the carapace. There is no trace of such an accessory tooth in *T. roosevelti*.

The basal antennal joint in our species is not wholly smooth, as it has been described for *T. alcocki*, or low and almost indistinguishable, as in *imparimanus*; neither is the crest what one would in any sense call denticulated, which it plainly is in *T. investigatoris*, *exctastica*, *gardineri*, and *kükenthali*, or armed with two large and prominent teeth fused at the base as in *T. tenuipes*. In *T. roosevelti* the basal joint, as described above, has a well-formed high crest visible in dorsal view, rather smooth appearing and at most no more than obscurely denticulated, revealing, under the magnifier, small, low, irregularly placed swellings or obsolescent small tubercles.

With respect to the character of the basal joint and the armature of its hands, *T. roosevelti* stands near *T. alcocki*; in the equality of the chelipeds, proportions and general appearance of the front, carapace, and lateral teeth, near *T. gardineri*. From the former our species differs in having a relatively wider and deeper incision or sinus between the median lobes of the front, in having the fingers longer instead of shorter than the palmar portion of the hand, and in being armed with nearly twice as many or more than twice as many spinules on the hinder margin of the propodus of the last pair of legs. From *T. gardineri* our species differs by virtue of the fact that the submedian lobes of the front overlap the median lobes in not having a truly or plainly denticulated crest on the basal antennal joint, and in the relatively longer fingers.

Even if Miss Gordon's recently described *T. malaccensis* (Bull. Raffles Mus., No. 14, p. 176, figs. 2, 3, 1938) is to be considered one of the species possessing a six-lobed front, the fact that the outer lobes of the front are marked off from the submedian lobes by a mere convexity of the anterior margin instead of a well-marked sinus or incision sets it well apart from the one we have here described.

<i>Platypodia rotundata</i> (Stimpson).....	2♂ 2♀
<i>Actea dovii</i> Stimpson.....	1♀
<i>Actea sulcata</i> Stimpson.....	1♀
<i>Micropanope xantusii</i> (Stimpson).....	1♂ 4♀ (3 ovig.) 5 juv.

*Teleophrys cristulipes* Stimpson.....2♀ (1 ovig., 1 juv.)  
*Pachygrapsus minutus* Milne-Edwards.....1♀ ovig., 20 juv.

In the figure given by Milne-Edwards for *P. minutus* (Nouv. Arch. Mus., Paris, vol. 18, p. 292, pl. 14, fig. 2, 1873) the posterior border of the merus of the last pair of legs is without armature except at the postero-distal angle.

The merus of the last pair of legs of *P. murrayi*, as Calman states (Proc. Zool. Soc. London, 1909, p. 708, pl. 72, figs. 4, 5, 1909), "has two smaller teeth [besides those at the postero-distal angle] side by side near the proximal end." One could perhaps better describe these two small, yet somewhat elongated, juxtaposed teeth as a bidentate, tuberculiform tooth. From between the two denticles of this bidentate tooth a stiff hair or seta arises; proximal to this tooth are two or three little denticles on the inner, ventral margin of the joint. The upper margins of the ambulatory legs are furnished with a close-set fringe of "feathered" setae, thickest on the propodi of the last pair of legs, and probably present on all joints. The hairs of this fringe are easily broken off, at least in preserved material, as they are more or less wanting on certain legs and joints. Such a fringe is not mentioned by Dr. Calman nor shown in his figure of the type. The front of our specimens is about, or a little more than, half the width of the carapace; otherwise Calman's description of *murrayi* fits them almost exactly.

Because of this apparent difference I was inclined to believe Calman's species other than the one briefly described by Milne-Edwards. However, the view of a number of authors that the former is identical with the latter is fully substantiated in a communication which I recently received from Prof. L. Fage, of the Muséum National d'Histoire Naturelle, Paris, to whom I am more than grateful:

Je viens d'examiner les cinq échantillons de *Pachygrapsus minutus* qui ont servi à la description de Milne-Edwards. Ils possèdent la petite épine géminée au bord postérieur du meros de la dernière paire de pattes.

J'ai comparé ces échantillons avec la fig. du *Scarma murrayi* et je n'ai trouvé aucune différence.

La synonymie n'est pas douteuse.

*Percnon abbreviatum* (Dana).....2 juv. (♂♀)

A first eastern Pacific record for the species, originally described from Tahiti and taken since that time in the Indian Ocean, and at Hawaii, Fanning, Ocean, and Wake Islands.

In the absence of an available key to the valid species of *Percnon*, the following tentative one is offered.



## KEY TO THE SPECIES OF THE GENUS PERCNON

- A<sup>1</sup>. Pilose groove along upper margin of chelae about or nearly as long as the upper margin of palm.
- B<sup>1</sup>. Anterior margin of epistome armed with three spines, one median and one at either end.
- C<sup>1</sup>. Second of lateral teeth of carapace, counting the one at anterolateral angle, inconspicuous, very much smaller than third or indeed any of the others (this character holds for even the smaller specimens). Carapace squarish, scarcely if at all longer from notch in extremity of rostrum to posterior margin than wide; rostral notch shallow, the spines forming it widely spread. . . . . *abbreviatum* (Dana).  
(Proc. Acad. Nat. Sci. Philadelphia, vol. 5, p. 252, 1851; Crustacea U. S. Explor. Exped., vol. 1, p. 373, 1852, atlas, pl. 23, fig. 11, 1855.)
- C<sup>2</sup>. Second lateral tooth at most only slightly smaller or shorter measured on the outer margin than third. Carapace longer from rostral notch to posterior margin than wide; rostral notch not noticeably shallow nor spines forming it particularly widespread  
*pilimanus* (A. Milne-Edwards).<sup>6</sup>  
(Nouv. Arch. Mus. Hist. Nat. Paris, vol. 9, p. 300, pl. 14, fig. 5, 1873.)
- B<sup>2</sup>. Anterior margin of epistome with but a single, the median, spine. Second of lateral teeth of the carapace, counting the one at the anterolateral angle, of good size, but smaller than third, measured on the outer margin only about two-thirds as long as the third. Carapace more or less rounded or narrowed anteriorly, longer than wide. . . . . *demani* Ward.<sup>6</sup>  
(Bull. Raffles Mus., No. 9, p. 24, pl. 3, fig. 3, 3a, 1934.)
- A<sup>2</sup>. Pilose groove on upper margin of chela relatively short, never more than half the length of the palm, often much less. Pubescence on palm other

<sup>6</sup>This species, at least in well-developed males, is characteristically distinguished from all other Percnons by the conspicuous, thick, felted patch of hair on the inner side of the palm, and on the inner upper surface of the merus. In some females that I have seen, the pilose patch is not only reduced in size, but the hairs forming it are shorter and less conspicuous than in the male. I have examined three specimens lent me by the Museum of Comparative Zoölogy through the kindness of Dr. Fenner A. Chace, Jr., in which the second lateral tooth is a little smaller and shorter than the third, if only slightly so. In Milne-Edwards' figured type the reverse seems true; the second tooth, as drawn, is definitely larger and stouter than the third.

<sup>6</sup>In the U. S. National Museum collections I have discovered four specimens, two small females from the Philippines and a small male and medium-sized female from the Celebes, which I believe represent the species which de Man had questionably assigned to *P. abbreviatum* (Dana) and on which Ward quite rightly bestowed a new name, *demani*. De Man was influenced in his tentative determination by the reduced size of the second lateral tooth of the carapace, which, however as he remarked, can in no sense be described as inconspicuous. It is very inconspicuous in true *abbreviatum*. In Ward's half-tone illustration of *demani* the second lateral tooth appears at least as large or as long as the third, if not longer. Unless this second tooth is noticeably smaller than the third in the specimen itself, the figure represents a species other than *demani*.

than in groove slight or wanting. Anterior margin of epistome armed with three spines, median and pair of laterals.

- B<sup>1</sup>. Groove very short, inconspicuous, scarcely a sixth of the length of the upper margin of palm or less.....*planissimum* (Herbst).<sup>7</sup>  
(Naturges. Krabben u. Krebse, vol. 3, pt. 4, p. 3, pl. 59, fig. 3, 1804. Alcock, Journ. Asiatic Soc. Bengal, vol. 69, p. 439, 1900.)
- B<sup>2</sup>. Groove longer, about a third (from a fourth to a half) the length of the upper margin of the palm.....*gibbesi* Milne-Edwards.  
(Ann. Sci Nat., ser. 3, Zool., vol. 20, pp. 180, 146, 1853. Rathbun, Bull. 97, U. S. Nat. Mus., p. 337, pl. 105, 1918.)

*Gecarcinus planatus* Stimpson.....1♂

One of the few land crabs seen. In former years this species was exceedingly abundant on Clipperton. It is possible that the drove of wild pigs loose on the island has so reduced their numbers that they now seem scarce.

**Sullivan Bay, James Island, Galápagos, July 24 (sta. 15-38) ;**  
shore and tide-pool collecting.

*Lepcophtheirus dissimulatus* Wilson.....1♂ 5♀  
*Crangon cylindricus* Kingsley.....1  
*Crangon malleator* (Dana).....2  
*Synalpheus nobili* Coutière.....3

One of three specimens assigned to this species is but tentatively placed here. In many respects it resembles a closely related species, *S. sanlucasi*. As it does not have the stout legs characteristic of that species, this specimen has been placed here as a variant perhaps of *S. nobili*.

<sup>7</sup> This species of *Percnon* and the next are very close and very similar. There is some variation in the length of the pilose groove of the upper margin of the hand. The characteristically short groove of *planissimum* holds for all specimens of more than three-fourths of an inch in width. In some smaller or immature specimens, chiefly females, the groove appears relatively longer than in larger, better-developed individuals. Specific distinctions are best exhibited in well-developed males.

There is another character not referred to in the key that seems to hold for many specimens of either of these two species of *Percnon*, but not for all unless I am mistaken in some of my identifications. In *P. planissimum* the teeth of the lateral margin of the carapace, at least those following the one at the anterolateral angle, are more or less subequal; the second and third teeth, counting the extra orbital tooth, measured on their outer margins are about of equal length. In *P. gibbesi* the outer margin of the second lateral tooth, counting the one at the anterolateral angle of the carapace, measured on the outer margin is in general or in many specimens appreciably a little shorter than the third.

<i>Pachycheles biocellatus</i> (Lockington)	1♂
<i>Calcinus obscurus</i> Stimpson	1
<i>Dynomene ursula</i> Stimpson	1♀
<i>Platypodia genuata</i> Rathbun	1♂
<i>Actea dozii</i> Stimpson	2♀
<i>Leptodius cooksoni</i> Miers	1♂ 2♀ (1 ovig.)
<i>Eriphia granulosa</i> A. Milne-Edwards	3♂ 4♀ (2 ovig., 3 juv.)
<i>Eriphides hispida</i> (Stimpson)	3♀
<i>Grapsus grapsus</i> Linnaeus	1♂
<i>Pachygrapsus transversus</i> (Gibbes)	1♂
<i>Percnon gibbesi</i> (Milne-Edwards)	1 juv.
<i>Mithrax nodosus</i> Bell	6♂ 9♀ 3 juv.
<i>Teleophrys cristulipes</i> Stimpson	3♂ 1♀ 3 juv.

**Narborough Island**, Galápagos, July 25 (sta. 16-38), shore collecting, east side, opposite Tagus cove.

<i>Palaemon ritteri</i> Holmes	4
--------------------------------	---

Rostral teeth  $\frac{8}{2-3}$ ; in three of the specimens the first two teeth of upper series are definitely on the carapace.

<i>Petrolisthes</i> species	4
<i>Calcinus obscurus</i> Stimpson	1
<i>Leptodius cooksoni</i> (Miers)	10♂ 3♀ (2 ovig.) 2 juv.
<i>Ozius perlatus</i> Stimpson	2♂ 1♀
<i>Ozius tenuidactylus</i> (Lockington)	2♂ 4♀
<i>Geograpsus lividus</i> (Milne-Edwards)	1♂ 1♀
<i>Mithrax nodosus</i> Bell	1♂

**Tagus Cove, Albemarle Island**, Galápagos, July 26 (sta. 18-38), from anchor chain at anchorage, 10 a. m., 50 fathoms.

<i>Munida mexicana</i> Benedict	28
---------------------------------	----

The specimens are all about the size of or slightly smaller than the material mentioned in Benedict's description of the species. Though first taken by the United States Fish Commission Steamer *Albatross* from 65 fathoms in Panama Bay in 1888, the species was based on the type which was obtained the same year by the same vessel while operating in 78½ fathoms off Charles Island in the Galápagos. Additional specimens from that particular cruise were taken off Chatham Island, Galápagos, in the Gulf of California, and off Magdalena Bay, in depths ranging from 9½ to 151 fathoms. All told, the *Albatross*

captured 23 specimens, including the type. Until our own 28 specimens were found sitting on the anchor chain by Lieutenant Commander Kelly as the anchor was being hoisted prior to leaving our anchorage off Tagus Cove, the species had been reported only once since the *Albatross* collected it. Heller and Snodgrass obtained a single specimen from a rocky reef north of Tagus Cove, March 3, 1899.

**Elizabeth Bay, Albemarle Island, Galápagos, July 26 (sta. 19-38),** landed in bay at south end of black beach north of mangroves, north of two red islands.

*Crangon strenuus* (Dana).....1

The antennular peduncles of this one specimen are stouter than what may be considered typical for the species; the larger chela is a little less massive and has its proximal portion behind the notches in the dorsal and ventral margins of the hand slightly longer than usual. For want of more and sufficient material, this specimen has been identified as *C. strenuus* with reservations.

*Callianidea laevicauda occidentalis* Schmitt.....1

Only the anterior portion of this specimen seems to have been obtained.

*Petrolisthes* species .....6

*Clibanarius* sp. ....9

*Calcinus obscurus* Stimpson.....6

*Leptodius cooksoni* (Miers).....14♂ 4♀

*Pinnaxodes chilensis* (Milne-Edwards).....1

This is the first time this species has been observed in the Galápagos Islands. Austin H. Clark, who has reported upon the echinoderms collected, discovered this pea-crab in one of several sea-urchins, *Caenocentrotus gibbosus* (L. Agassiz and Desor).

*Grapsus grapsus* (Linnaeus).....1♀ ovig.

*Pachygrapsus transversus* (Gibbes).....1♂ 5♀ (3 ovig.)

*Mithrax nodosus* Bell.....1♂

**Post Office Bay, Charles Island, Galápagos, July 27 (sta. 21-38),** specimens gathered ashore by members of the crew.

*Eriphides hispida* (Stimpson).....1♂

**Off Gardner Bay, Hood Island, Galápagos, July 27 (sta. 22-38),** at anchorage, with electric light off gangway, 11 p. m., dip net.

A number of each of three species of free-swimming copepods:

*Temora stylifera* (Dana)

*Centropages furcatus* (Dana)

*Undinula caroli* Scott

**South Seymour Island, Galápagos, July 29 (sta. 23a-38),** at anchorage, with electric light from gangway, 11 p. m., dip net.

A number of each of three species of free-swimming copepods:

*Eucalanus attenuatus* (Dana)

*Pleuromamma piscki* Farran

*Undinula caroli* Scott

**James Bay, James Island, Galápagos, July 30 (sta. 24-38),** from bottom sample taken in 24 fathoms.

*Processa canaliculata* Leach.....2

**Chatham Bay, Cocos Island, August 2, shore.**

Callianassid .....1

A small specimen in poor condition.

*Coenobita compressa* Guérin.....2

**Wafer Bay, Cocos Island, August 2, in vicinity of treasure hunter's camp.**

*Cardisoma crassum* Smith.....1♂

**Off Chatham Bay, Cocos Island, August 3 (sta. 26-38 and sta. 27-38 respectively),** parasites from 116-pound sailfish caught by F. B. Adams; and copepod found in dish in which two sucker fish, *Echeneis remora* Linnaeus, taken from the sailfish had been placed.

*Gloiopotes ornatus* Wilson.....2♂ 9♀

All but one young female were removed from the sailfish (26-38); this specimen (27-38) was found in dish with the sucker fish.

*Pennella instructa* Wilson.....1

To this *Pennella* (26-38) was attached a single fleshy barnacle, *Conchoderma*, very probably *C. virgatum* (Spengler). The *Pennella*

was not wholly complete, and apparently not a fully developed specimen, but Dr. C. B. Wilson, who made the determination, believes that it may safely be called *P. instructa*.

**Old Providence Island, Colombia, August 6 (sta. 30-38), shore, reef, and tide-pool collecting.**

<i>Trachypenaeus similis</i> (Smith) .....	4
<i>Crangon caudci</i> (Guérin) .....	7
<i>Crangon formosus</i> (Gibbes) .....	2
<i>Crangon cristulifrons</i> (Rathbun) .....	1
<i>Crangon bahamensis</i> (Rankin) .....	11
<i>Crangon heterochaelis</i> (Say) .....	2
<i>Crangon</i> species .....	1
<i>Synalpheus fritzmülleri</i> Coutière .....	1
<i>Synalpheus</i> near <i>rathbuni</i> Coutière .....	1

The poor condition of this small specimen precludes a more positive determination or even an adequate description should it prove to be new. The ambulatory legs and the large chela remind one strongly of *S. rathbuni*. The conical tubercle of the chela anteriorly carries the suggestion of a tiny spinule. There are only four articles to the carpus of the second legs. The frontal appendages appear to be much as in the type of *S. rathbuni*; the posterior pair of spines on the dorsum of the telson are not quite so large.

<i>Lysmata moorci</i> (Rathbun) .....	2
<i>Thor paschalis</i> (Heller) .....	1
<i>Brachycarpus biunguiculatus</i> (Lucas) .....	4
<i>Macrobrachium olfersii</i> (Wiegmann) .....	1
<i>Palacmon tenuicornis</i> Say .....	1♀ ovig.
<i>GNathophyllum americanum</i> Guérin .....	1♀ ovig.
<i>Stenopus semilaevis</i> v. Martens .....	5
<i>Petrolisthes galathinus</i> (Bosc) .....	1♂
<i>Petrolisthes tridentatus</i> Stimpson .....	1♂
<i>Petrolisthes</i> near <i>quadratus</i> Benedict .....	2 juv.
<i>Calcinus tibicen</i> (Herbst) .....	8
<i>Clibanarius tricolor</i> (Gibbes) .....	36
<i>Dardanus venosus</i> (H. Milne-Edwards) .....	2♂
<i>Pagurus marshi</i> Benedict .....	1
<i>Hippa cubensis</i> (Saussure) .....	1♂
<i>Dromia erythropus</i> (George Edwards) .....	1♀
<i>Pitho aculcata</i> (Gibbes) .....	1♂ 2♀ (1 ovig.)

<i>Mithrax acuticornis</i> Stimpson.....	3♂
<i>Mithrax sculptus</i> (Lamarck).....	1♀
<i>Mithrax coryphe</i> (Herbst).....	3♂ 2♀ ovig.
<i>Mithrax ruber</i> (Stimpson).....	2♂ 1♀ 1 juv.
<i>Macrocoeloma diplacanthum</i> (Stimpson).....	1♀ ovig.
<i>Macrocoeloma subpanallclum</i> (Stimpson).....	1♂
<i>Microphrys bicornutus</i> (Latreille).....	1♀ 2 juv.
<i>Portunus ordwayi</i> (Stimpson).....	1♂
<i>Paraliomera dispar</i> (A. Milne-Edwards).....	6♂ 6♀
<i>Actea setigera</i> Milne-Edwards.....	2♂ 1♀
<i>Xanthodius denticulatus</i> (White).....	4♂ 6♀
<i>Micropanope barbadensis</i> (Rathbun).....	6♂ 5♀ (2 ovig.) 1 juv.

All these except the largest, best-developed male have the palms more or less completely granulated as in one of the females among the 13 specimens examined by Miss Rathbun.

<i>Chlorodiella longimana</i> Milne-Edwards.....	1♂ 1♀
<i>Pilumnus holosericus</i> Rathbun.....	3♂ 3♀
<i>Eriphia gonagra</i> (Fabricius).....	1♀
<i>Grapsus grapsus</i> Linnaeus.....	1♂ 1 juv.

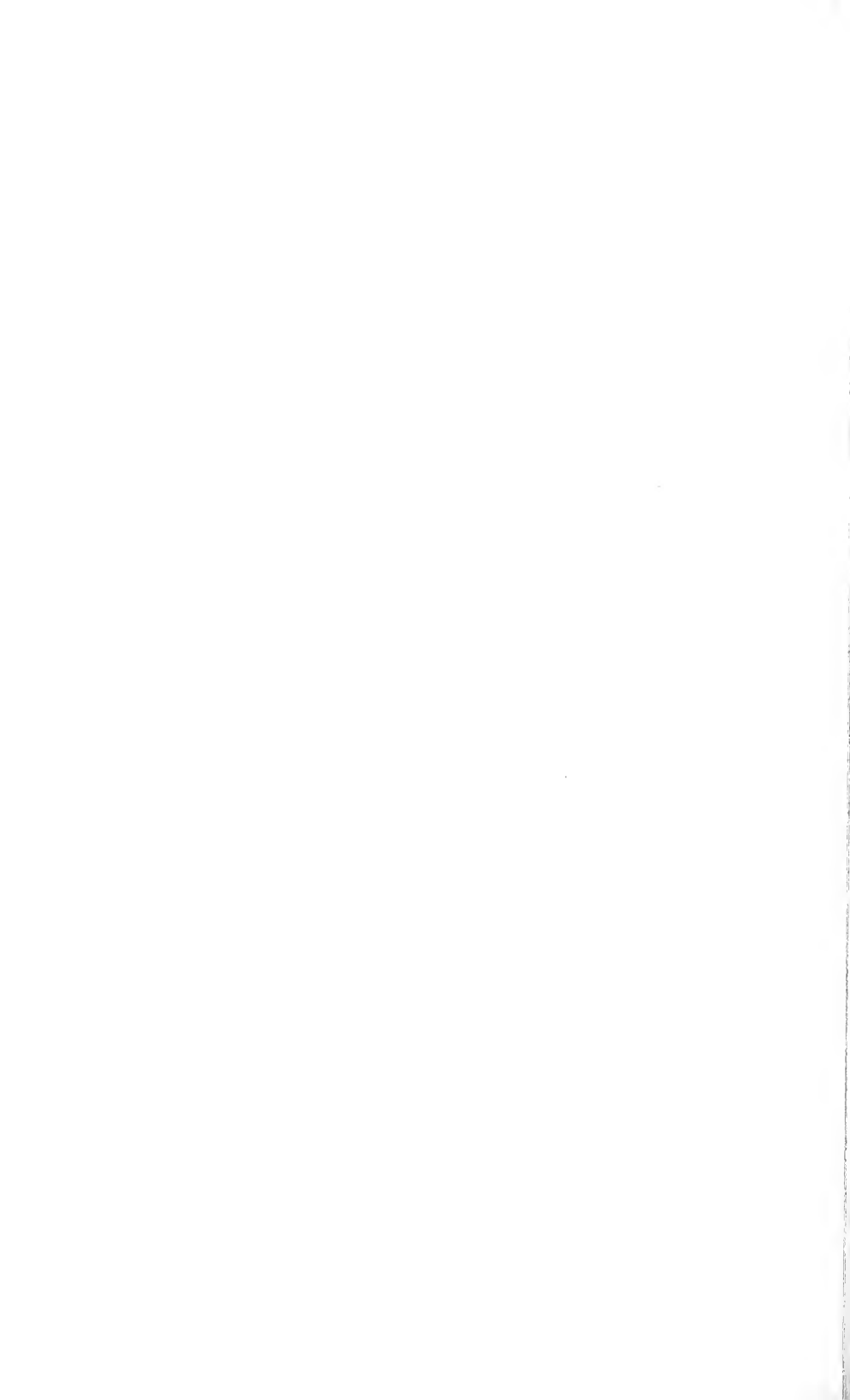





THE CLIPPERTON ATOLL FROM THE NORTHWEST. TAKEN FROM THE FORETOP OF THE U.S.S. "HOUSTON"  
(FROM PHOTOGRAPHS BY J. P. M. JOHNSTON)



1. CLIPPERTON ISLAND LANDING FROM THE NORTHEAST



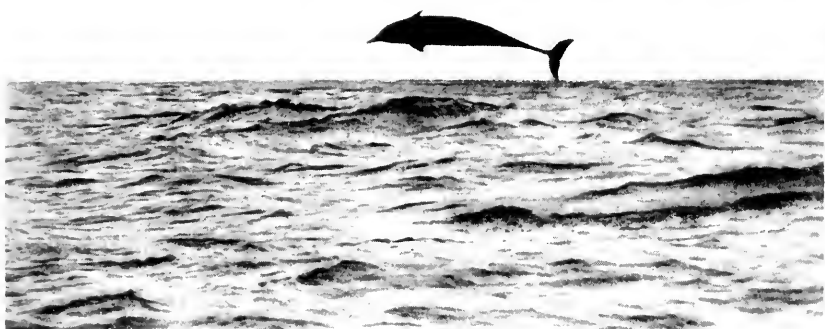

LEAPING PORPOISES, HOOD ISLAND, JULY 28  
(PHOTOGRAPHS BY R. B. THOMPSON)



SMITHSONIAN MISCELLANEOUS COLLECTIONS

VOLUME 98, NUMBER 7

A NEW PALM FROM COCOS ISLAND  
COLLECTED ON THE PRESIDENTIAL  
CRUISE OF 1938

(WITH 26 PLATES)

BY  
O. F. COOK



(PUBLICATION 3532)

CITY OF WASHINGTON  
PUBLISHED BY THE SMITHSONIAN INSTITUTION  
MAY 29, 1939



SMITHSONIAN MISCELLANEOUS COLLECTIONS  
VOLUME 98, NUMBER 7

A NEW PALM FROM COCOS ISLAND  
COLLECTED ON THE PRESIDENTIAL  
CRUISE OF 1938

(WITH 26 PLATES)

BY  
O. F. COOK



(PUBLICATION 3532)

CITY OF WASHINGTON  
PUBLISHED BY THE SMITHSONIAN INSTITUTION  
MAY 29, 1939

The Lord Baltimore Press  
BALTIMORE, MD., U. S. A.



A NEW PALM FROM COCOS ISLAND COLLECTED ON  
THE PRESIDENTIAL CRUISE OF 1938

BY O. F. COOK

(WITH 26 PLATES)

Cocos is a small, mountainous, forest-covered island less than 4 miles across, lying in the Pacific Ocean about 250 miles southwest of Panama, chiefly known as a resort of buccaneers and seekers of buried treasure. The mountains rise to nearly 3,000 feet, with surfaces too precipitous for cultivation or grazing, so that permanent settlements have not been made, and the native vegetation has not been exterminated. The new palm was collected by Dr. Waldo L. Schmitt, of the United States National Museum, during the 1938 cruise of President Roosevelt on the U.S.S. *Houston*. It is a tall, handsome palm, of a group that has received relatively little study. Though not related to the coconut palm, it is remarkably similar in size and general appearance, and apparently was responsible in part for the name of the island. Certainly it was included with the coconut by Lionel Wafer in the account of his visit to Cocos Island in 1685, in "A New Voyage and Description of the Isthmus of America," published in 1699.

A nearly complete series of specimens was obtained by Dr. Schmitt, including flowers preserved in formalin, and photographs showing the native conditions and habits of growth, with the result that detailed comparisons with related palms from the mainland of Central and South America are made possible in this paper. Entire inflorescences and sections of the trunk were brought back, which make it possible to determine and to present illustrations of several features usually disregarded in descriptions, though of biologic and taxonomic interest. Palms are poorly represented in collections, and many have been described from fragmentary material, with only a few of the distinctive characters represented.

The study of palms has remained backward compared with other branches of tropical botany, notwithstanding that popular interest in palms is perhaps greater than in any other plants. No other order of plant life contributes so much to the tropical landscape or finds so many uses among the tropical peoples. The reason why collectors of other plants usually neglect or avoid the palms is that specimens are

difficult to obtain and too bulky to be handled by herbarium methods. Collecting a single palm may take more time and trouble than a dozen or a score of herbaceous species, or of branching, small-leaved trees. The leaves, flowers, and fruits of the tall forest palms may be completely out of reach, since many of the larger kinds have the habit of not flowering or fruiting until they emerge from the forest, or at least are tall enough to reach the direct sunlight, at 30 or 40 feet, so that climbing or cutting is necessary before any detailed study can be made. Felling a tall palm in a tangled tropical forest often proves difficult, even after the trunk is severed, but Dr. Schmitt was able to enlist for such an adventure a party of men<sup>1</sup> from the cruiser.

Since few of the related palms have been illustrated, the photographs from Cocos Island are of special value. Several of the illustrations are from photographs obtained for Dr. Schmitt by R. B. Thompson, who took part in the palm excursion. The specimens were collected August 1, 1938, and are preserved in the United States National Herbarium.

Since the name *Rooseveltia* appears not to be preoccupied in botany, it is a pleasure to accede to the wish of Dr. Schmitt that the beautiful palm of Cocos Island, if it proved to be new, might bear the name *Rooseveltia frankliniana*, in honor of President Roosevelt.

#### HABITS OF ROOSEVELTIA AND RELATED PALMS

The new palm is related to the well-known "royal palms" of Florida and the West Indies (*Roystonea floridana*, *R. regia* and *R. oleracea*), and to the mountain palms of Puerto Rico and neighboring islands (*Acrista monticola*). Other related palms are known from different localities in the tropical forest regions of South America, and through Central America to Guatemala. About 40 species have been described under the generic name *Euterpe*, others under *Hyospathe*, *Prestoca*, *Orcodoxa*, *Acrista*, *Catis*, *Plectis*, *Oenocarpus*, and *Jessenia*.

The royal palms, the largest and best-known members of the group, are readily recognized by their massive symmetrical trunks, like columns of marble, but among the other kinds are even more beautiful forms. Some are known as mountain palms, from their habit of growing at the summits of tropical mountains, above the dense forests that cover the lower slopes; others live in swamps or among the undergrowth, in the permanent shade of the forest. Barren soils or rocky

<sup>1</sup>Lt. Comdr. R. M. Peacher; Lt. L. M. LeHardy; Ensigns J. P. M. Johnston, R. W. Meyers, and M. H. Buass; and J. L. Learson, M. S. Simon, R. B. Thompson, Jack Barron, T. M. O'Neil, Joe Balicki, and L. F. McPherson.

outcrops unfavorable for other vegetation sometimes give the palms exclusive possession of the mountain summits, with the elevated groves of palms standing out like islands in a sea of forest verdure.

All the mountain palms and their forest relatives are of slender habit, with smooth, clean trunks prolonged by a green column of closely wrapped leaf-sheaths, as in the royal palms, but with the foliage usually a lighter, fresher green, more regular and more open, so that the general effect is exceedingly graceful. The name *Oreodoxa*, meaning "mountain-glory," was very appropriately given to one of the high-altitude palms of Venezuela, discovered by Willdenow, but misapplied by Martius to the royal palms of the West Indies, which grow in the lowlands.

The new genus from Cocos Island finds its affinities with the mountain palms, though larger than other members of that series and different in many features from the mountain palms of the West Indies. The trunk is tall, rigid, and columnar, not attaining the thickness usual in the royal palms, but the crown of foliage having an equal spread and a form even more attractive. A trunk measured by Dr. Schmitt was more than 66 feet long; the leaf-blades attain 13 feet in length, and the segments or pinnae of the leaves are nearly 4 feet long. The open appearance of the leaf-crown is determined by the pinnae not being crowded together and set at different angles to the midrib, as in the royal palms, but regularly spaced and positioned, drooping and swaying in the graceful manner reckoned by many writers as the special charm of the coconut palm, a deceptive similarity that allowed the native Cocos Island palm to remain unrecognized, although every visitor must have seen it. The nature of the resemblance may be appreciated by referring to small photographs taken for Dr. Schmitt by Mr. Thompson and reproduced at the top of plate 13. On the left is a group of coconut palms growing at Wafer Bay, on the right a profile of one of the native palms, emerging above the forest.

#### COCOS ISLAND AS DESCRIBED BY LIONEL WAFER

The remarkable similarity of the foliage makes it easy to understand how the palms that Wafer and later visitors saw on the hills of Cocos Island would be identified with the coconut palms that grew along the shore, and how this error might complicate the history of the coconut palm, as well as conceal the existence of a different native type. Wafer's circumstantial account of wild coconut palms growing freely on the forest-covered hills of an uninhabited island doubtless has contributed greatly to the belief, still held by some, that the coco-

nut originated in the Pacific Islands. Opposed to this theory is the fact that none of the endemic palms of the islands or of the Asiatic continent is related to the coconut, whereas on the American continent, and especially in South America, are scores of closely related genera and hundreds of species, composing the coconut family.

Cocos Island was described by Wafer as "a very charming place," "so called from its coco-nuts, wherewith 'tis plentifully stored," the impression of abundance no doubt being drawn largely from the native palms growing on the hills in the interior of the island, readily seen from the ship but not easily visited ashore. The coconut palms no doubt were confined to the lower ground, near the landing place, which would seem to have been cleared and planted by previous inhabitants, in view of the many coconuts featured in Wafer's narrative. All coconut palms had disappeared when Cocos Island was visited by Henry Pittier, in 1898 and 1902, in the interest of the government of Costa Rica.

To quote further from Wafer<sup>2</sup>:

Tis but a small island, yet a very pleasant one; for the middle of the island is a steep hill, surrounded all about with a plain, declining to the sea. The plain, and particularly the valley where you go ashore, is thick set with coconut trees, which flourish here very finely, it being a rich and fruitful soil. They grow also on the skirts of the hilly ground in the middle of the isle, and scattering in spots upon the sides of it, very pleasantly. But that which contributes most to the pleasures of the place is, that a great many springs of clear and sweet water rising to the top of the hill, are there gather'd as in a deep large bason or pond, the top subsiding inwards quite round; and the water having by this means no channel whereby to flow along, as in a brook or river, it overflows the verge of its bason in several places, and runs trickling down in many pretty streams . . .

Nor did we spare the Coco-nuts, eating what we would, and drinking the milk, and carry several hundreds of them on board. Some or other of our men went ashore every day; and one day among the rest, being minded to make themselves merry, they went ashore and cut down a great many coco-trees; from which they gathered the fruit, and drew about 20 gallons of milk. Then they all sat down and drank healths to the King, queen, &c. They drank an excessive quantity: yet it did not end in drunkenness; but however, that sort of liquor had so chilled and benum'd their nerves, that they could neither go nor stand: Nor could they return on board the ship, without the help of those who had not been partakers in the frolick: nor did they recover it under 4 or 5 days time . . . (pp. 175, 176).

If this account be credited, the coconut palms of Wafer's time must have survived from an earlier settlement of people on the island,

<sup>2</sup> Wafer, Lionel, *A new voyage and description of the Isthmus of America*. Pp. 191-193. 1699.

of which other traces might be found if adequate search were made outside the range of the treasure-hunters. The coconut is strictly a sun palm, unable to develop under shade conditions, and hence unable to compete where forest vegetation is allowed to grow. Tall coconut palms in abandoned plantings may survive for many years before they are covered by the forest growth, but none of the seedlings develop and the old palms die out eventually.

Other parties of buccaneers may have cut more of the coconut palms at Wafer Bay and hastened their extermination, but all had disappeared by the end of the nineteenth century. The only coconut palms that Pittier found at Wafer Bay were a recent small planting of nuts brought by a treasure-seeker from the mainland of Costa Rica, at Puntarenas. At another locality, near the southwestern end of the island, not accessible to landing from the sea, Pittier encountered a few other coconut palms of a different variety, not recognized on the mainland, and possibly a remnant from the former period when the Island was at least temporarily populated before Wafer's time.

Pittier was the first to recognize that the palms on the hills were not coconuts, although no specimen was obtained. But his verbal communication was definite, and was noted in Contributions from the U. S. National Herbarium, volume 14, page 291, published in 1910. Also in "A List of the Plants of Cocos Island," by Alban Stewart, in the Proceedings of the California Academy of Sciences, January 1912, page 388, there is mention of "an undetermined species of palm occurring quite abundantly on the hillsides above both Chatham and Wafer Bays." Specimens with immature fruits were collected, but were not identified. Several other scientific expeditions reporting on the plants of Cocos Island seem to have overlooked the native palm.

#### OTHER CABBAGE PALMS

To the early explorers and the writers of the colonial period the royal palms and the related mountain palms were known as "cabbage palms," referring to their use as food. The "cabbage" was the tender edible bud of the palm, borne at the top of the trunk, wrapped in a green cylinder of sheathing leaf-bases. The cabbage of the coconut palm and of many others could be eaten in emergencies, but the royal and the mountain palms were held in greatest repute, and in some of the tropical colonies were destroyed in great numbers or even completely exterminated in districts that became populous. The palms of this group which still survive in the West Indies and in Central America are remote from settlements or occur in places so difficult of

access that at least a few are allowed to mature to the stage of producing seeds. These the birds scatter, so that rare individuals may be found.

Appreciation of the royals and similar palms for decorative planting, as in southern Florida and California, is a relatively recent development, mostly in the present century, though now attaining great proportions. The real-estate values of palms in Florida would be reckoned in many millions, single well-grown individuals often being bought at high prices, \$500 or more.

Some of the related palms in South America, notably the *assai* palm of Brazil, are spared by the natives for the sake of their small oily fruits, like grapes or cherries, borne in huge clusters. A valuable food beverage is prepared, sometimes called "wine" on account of its rich purple color, though not fermented, and by others compared to chocolate. Alfred Russell Wallace and other scientific travelers have given very favorable accounts of the *assai* as tasty and wholesome, referring to its extensive use in the district of Para as "one of the greatest luxuries that the place affords." Similar uses are reported of the fruits of related palms in Brazil and Guiana.

That the Cocos Island palm has not been exterminated no doubt is explained by the failure to establish permanent settlements, and it may be hoped that protection will be given, should the island be occupied in the future. The palm probably can be cultivated in the Canal Zone, possibly also in Florida, in sheltered locations, and as a conservatory palm would be very striking. Fortunately Dr. Schmitt was able to obtain a quantity of seeds, which arrived in good condition and were planted at once, but with most of the palms germination requires several months, and the young seedlings grow very slowly. Of the several seedlings also brought from Cocos Island by Dr. Schmitt, two survived in the Washington greenhouses of the Department of Agriculture.

#### OTHER PALMS ON SMALL ISLANDS

Although it is not impossible that the palm of Cocos Island may also occur on the mainland, this is hardly to be expected in view of the localized distribution of many species and monotypic genera. It is much more probable that Cocos Island will share with several other small islands in remote parts of the world the distinction of producing a strictly endemic palm, found nowhere else, except as some of the island species are being cultivated in other countries. The most important commercial species, the so-called "Kentia" palm, *Denea*

*forsteriana*, familiar as a decorative plant, exists in the wild state only on Lord Howe Island, between Australia and New Zealand. The Canary date palm, *Phoenix canariensis*, hardier and more imposing than the commercial date palm, is restricted in nature to the single island Palma, northwest of Tenerife. The Bermuda palmetto, *Sabal blackburniana*, is a distinct species, all the other palmettoes being found on the American continent or in the West Indies. Navassa Island and Saona Island in the Caribbean Sea, have endemic species of *Pseudophoenix*.

One of the most beautiful fan-palms, *Erythea edulis*, with emerald-green foliage, a favorite ornamental along the coast of California, was introduced from Guadalupe Island, off Lower California, where the wild stock is nearly extinct. Other magnificent fan-palms are found in single islands of the Hawaiian archipelago, and elsewhere among the Pacific Islands. A remarkable new genus, *Pelagodoxa*, was discovered a few years ago in one of the Marquesas Islands. Also in southern latitudes, beyond the tropical belt, insular palms occur; *Juania australis* on Juan Fernandez, off the coast of Chile, and *Eora ultima*, a little-known palm on Chatham Island, southeast of New Zealand. Other species of *Eora* are found on Norfolk Island and Kermadec Island, and one on the main island of New Zealand.

The genera that now are confined to the small islands may be considered as remnants of richer floras existing formerly on the continents. Human agency, no doubt, has exterminated many palms in the regions that were populated in prehistoric times. But even before the human period other types of woody vegetation may have displaced many palms, with the development of continuous forests of branching small-leaved trees, which formed dense canopies of shade under which more primitive sun-palms were unable to grow.

Tolerance of shade has been acquired in different families of palms in several forest regions of the tropics, each region having its special flora of forest palms. The more primitive open-country palms are more widely distributed. Partial tolerance of shade, at least in the younger stages of development, is a positive requirement with all the forest palms, the extent of such tolerance often determining their ability to thrive in cultivation. The early stages of the forest palms may be more definitely specialized for shade conditions, as shown by longer petioles or more delicate foliage, than the later stages, which rise above the forest "roof" and so gain access to the full sunlight. To meet such requirements in the early stages of growth, locations with partial protection from sun and wind should be chosen for the

Cocos Island palm in southern Florida, Puerto Rico, or the Canal Zone, should the seedlings attain the transplanting stage. Permanent soil moisture is needed, of course, for any palms from humid tropical forests. All the hardy types of palms are adapted to open conditions, and do not thrive in the forest or under shade.

#### EUTERPE A TRADITIONAL NAME OF CABBAGE PALMS

The generic name *Euterpe*, used by Martius and subsequent writers for this group of palms, was borrowed without warrant from an East Indian genus not represented in America. The first specific name, *Euterpe globosa*, was proposed by Gaertner in 1792 for a palm described and figured in 1741 as *Pinanga sylvestris globosa* by Rumphius in the "Hortus Amboinensis," an important early work that served as the basis of many binomial names assigned by later writers. The failure of Gaertner to mention any specimen or locality leaves the name attached to the Amboina palm. The fruit is described and figured by Gaertner with an apical point, erect mesocarp fibers, and a lateral embryo, characters that do not appear in the American palms.

Martius recognized his mistake before the second volume of his "Historia Naturalis Palmarum" was completed, and directed in the index that the reference to Gaertner be suppressed. In his third volume he placed Gaertner's genus *Euterpe* as a synonym under the Malayan genus *Areca*, though continuing to use "*Euterpe* Mart." for the American palms. Also in the "Palmetum Orbignianum," published in 1847, Martius says "*Euterpe* Mart. non Gaertn." In the time of Martius it was customary for botanical authorities to modify definitions and change the applications of names in an arbitrary manner, instead of holding the names to their original applications, as is now considered necessary.

The transfer by Martius of the name *Euterpe* to South America occasioned the proposal by Blume in 1836 of a second name, *Calyptrocalyx spicatus*, for the same palm that Rumphius had described and Gaertner had called *Euterpe globosa*. Several other Oriental palms have simple inflorescences and globose seeds, and Gaertner may have seen some of these. A second species, *Euterpe pisifera*, established by Gaertner on a seed of unknown origin, also was identified by Martius with a Brazilian palm, but Gaertner's drawing of *Euterpe pisifera* has been identified by Herr Burret with *Heterospatha elata*, another East Indian palm, so that no occasion remains for further association of the name *Euterpe* with American palms.

Methods of classifying and naming plants have been profoundly altered since the work of Darwin gained credence for the idea of



gradual development of the organic world. From being concerned primarily with the fixing of names, classification has widened to a study of the courses of development, and is no longer limited to definitions or to logical analysis of the characters originally used in distinguishing groups, but calls for comparative study of any and all differences to the end of discovering and formulating new characters that mark the courses of development and the relationships of the groups to each other. The facts of development and adaptation determine the characters to be defined and the form of statements needed to present the differences clearly.

Floral characters are less specialized among the palms than in many other groups, but stages of specialization are marked as definitely by other features. The inflorescences and the floral envelopes, instead of being enlarged and expanded as in many of the groups that are pollinated by insects, have been greatly reduced and simplified in many of the palms, in order to be covered more effectively during the early stages of development. The usual protective functions of the floral envelopes in other groups of plants often are assumed among the palms by the spathes, or even by the leaf-sheaths, thus avoiding any exposure of the tender budding tissues to the sun or to the wind, or to insect injuries. Inflorescences have been simplified and floral envelopes have been reduced to rudimentary organs in many of the palms. That different courses of specialization have been followed in the various groups, though all in the direction of protecting the flowers, is evidence of the adaptive values of such specializations.

Characters framed for taxonomic use are no longer to be considered as permanent definitions, seeing that supposedly diagnostic differences may lose their significance and that changes in descriptions often become necessary when closer relatives are discovered and compared. For such purposes of gradual improvement of classifications and descriptions, it obviously is necessary that names be held to their original application instead of being borrowed or shifted from one group to another, as the custom was among the older writers.

In order that a generic name like *Euterpe* may always refer to the same group of plants, it should be attached inseparably to its original "type" species, instead of being allowed to drift away to other species that later may prove to belong to different genera, and so leave the original type to be renamed, as often has happened. The need of replacing these insecure methods began to be recognized several decades ago, but much of the confusion caused by casual or arbitrary transfers of names has still to be corrected. Darwin himself appreciated the basic

need of authentic names for scientific study, and left a legacy for establishing a universal list of all the genera and species that had been described, the well-known "Index Kewensis."

GENERA FROM SOUTH AMERICA AND THE WEST INDIES  
RELATED TO ROOSEVELTIA

The palms that have been referred to *Euterpe*, though having a general similarity in habits of growth, show numerous specialized differences, some of which will undoubtedly be formulated to serve as generic distinctions in place of the larger group which is still in part treated as a large composite genus. Four genera have already been recognized in this assemblage, *Acrista* in the West Indies, *Oreodoxa* in Venezuela, *Catis* in Brazil, and *Plectis* in Guatemala. Thirteen new species of *Euterpe*, mostly from Colombia, were described in a single paper published by Herr Burret in 1930, indicating that the group may be much larger than has been supposed.

The name *Acrista* was proposed in 1901 for the mountain palm of Puerto Rico, as distinct from the *assai* palm of Brazil, which Martius had described as *Euterpe oleracca*. This specific name was found to be invalid because in the same work Martius had placed under *Euterpe* a much older *Areca oleracca*, from the West Indies, originally described by Jacquin in 1763, and later recognized as the royal palm of Barbadoes, *Roystonea oleracca*. To resolve this confusion, the name *Catis martiniana* was suggested in 1901 for the palm that Martius had described as *Euterpe oleracca*.

The genus *Catis* is similar to *Acrista* in its seeds with ruminant endosperm and its seedlings with simple, bilobed leaves, but distinct in its slender long-jointed trunk, longer leaves with more numerous (80-100) narrow drooping pinnae, the inflorescence branches adnate to the rachis above the insertion of the subtending bract; surface of axis and branches closely beset with stellate-tufted scales, including the surface of the bracts; scars of male flowers often separated 2 to 4 times their diameter from the female flower-scars; male flowers with a large calyx, more than half as long as the petals, and oblong anthers 3 to 4 times as long as broad, notably longer than the filaments, instead of short anthers and long filaments as in *Acrista*; female flower-scars enclosed by prominent triangular bracts, much overlapping below, but little above.

*Catis* is not a mountain palm like *Acrista*, but thrives in swamps and water-courses in the lower Amazon Valley, its fruits being used extensively, as already stated. *Acrista* in Puerto Rico is confined to

mountain summits, and apparently requires somewhat open conditions, like most of the palms with small fruits eaten by pigeons or other birds. Many of the tropical forest trees, including some of the palms, have very large seeds, allowing seedlings to grow taller in the deep shade. The light requirements of *Acrista* were indicated by great numbers of the seedlings, only a few inches high, growing in the leaf-mold of a dense forest of tabonuco (*Dacryodes hexandra*) near Ysolina, south of Arecibo, visited in 1901. The forest floor was carpeted with the small palms, but in the permanent twilight none of them grew beyond the seedling stage. A photograph of this unusual pure-stand forest appears in the "Economic Plants of Puerto Rico," by O. F. Cook and G. N. Collins, Contributions from the U. S. National Herbarium, volume 8, page 132, 1903.

The genus *Orcodoxa*, in its original application to *Orcodoxa acuminata* Willdenow, a mountain palm of Venezuela, apparently is much closer to *Acrista* than to *Catis*, in having straight, naked branches, widely spaced flower-clusters, the male flowers with large compressed divergent pedicels, and the collar bracts very short, enclosing only the lower part of the female flower-scar, not covering the pedicels of the male flowers. These distinctive features are shown in Beccari's drawings of specimens from Venezuela, published in "The Palms Indigenous to Cuba." Beccari held that the name *Orcodoxa* was available for transfer to the royal palms, because Willdenow's *Orcodoxa* belonged to *Euterpe*. In reality Martius did not transfer *acuminata* to *Euterpe*, but listed it under *Orcodoxa*. The change of application apparently occurred incidentally, through disregarding the original use of *Orcodoxa* by Willdenow and featuring the better-known royal palms as representing that genus, instead of providing the new name that was needed for the royal palms and later was supplied in *Roystonia*.

#### A CLOSELY RELATED PALM IN GUATEMALA<sup>3</sup>

The ample material obtained by Dr. Schmitt allows many more characters to be studied than are usually treated, descriptions of most of the species being drawn from herbarium specimens alone. Several features of the new palm have not been previously recognized, some of them doubtless existing among the related types, but not yet formulated. Statements of new characters can have little meaning unless they take account of contrasting features of related forms. The palms are so different from other plants that many of the

<sup>3</sup> See description on page 22.

customary descriptive terms and expressions are applicable only with special meanings, and may prove misleading unless the actual features can be illustrated, preferably by photographs.

The Cocos Island palm is related rather closely to *Plectis ozevniiana* Cook, discovered in mountain forests of eastern Guatemala in 1902 and briefly described in the Bulletin of the Torrey Botanical Club, June 1904. The specimens of *Plectis* preserved in the United States National Herbarium include entire inflorescences and spathes, with several photographs taken in the type locality, so it is possible to illustrate several features for comparison with the new genus. Two species described under *Euterpe*, by Oersted from Costa Rica in 1858, *E. macrospadix* and *E. longipetiolata*, are well represented in the Herbarium. They are small, slender palms, with ruminant seeds and simple-leaved seedlings, related to *Acrista* but not to *Plectis* or to *Rooseveltia*.

## A COMPARISON OF ROOSEVELTIA AND PLECTIS

### HABIT AND TRUNK CHARACTERS

Though sharing many of the characters of *Plectis*, the Cocos Island palm is of more robust habit, with a thicker trunk and shorter, broader internodes, much wider than long, whereas the trunk of *Plectis* is more slender, with internodes often much longer than wide, sometimes twice as long. The base of the trunk is rather abruptly thickened, instead of tapering gradually as in *Plectis*, the leaf-sheath bundle is thicker, the stalk or petiole of the leaf is much shorter, and the rachis or midrib notably longer. The trunk is supported on a mass of coarse roots, 2 cm. or more in diameter, usually not appearing above the surface, but the lower side of the root mass is sometimes exposed on steep slopes of tenacious clay soil, as shown in plate 4.

A rather young palm, 25 or 30 feet high, was measured by Dr. Schmitt, 45½ inches around the thickened base of the trunk, and 20½ at 2 feet above the base; but notably larger palms were seen, so that a diameter of 40 cm. or more is indicated, rapidly narrowing to about 20 cm. and then narrowing very gradually to 12 or 13 cm., as shown by sections from the top of the trunk, with inflorescences still in place. The trunk of *Plectis* tapers much more gradually from the base, and becomes much more slender at the top.

The gradual thickening of the trunk is a feature that most of the palms do not share, the function of secondary growth being recognized only in the exogenous, bark-bearing plants, that have a special layer of cambium tissue for forming new wood. Although the trunk

of *Rooseveltia* has a fibrous structure like other palms, the arrangement of the fibers makes it possible for growth to continue, a hard shell being formed by closely compacted stout fibers, but with finer fibers outside, under a surface crust. The layer of large indurated fibers is about 2 cm. thick, with the fibers about 2 mm. in diameter, as shown in natural size at the right of plate 5; the layer of finer surface fibers is about 4 mm. thick. The fibers of the interior of the trunk are only 1 mm. or less in diameter, separated by loose pith. Each of the pith fibers has a large tubular channel on its mesial face, notably larger than the channels of the thick fibers or those of the smaller fibers near the surface. The finest fibers, delicate and filiform, are embedded in a light brownish corky stratum underlying a brittle surface crust, less than 1 mm. thick. The exposed surface of the crust, though appearing nearly smooth, is marked with fine longitudinal grooves, rather irregular and indistinct, usually 2 to 4 mm. apart, as shown at the left of plate 5. Where the surface is protected by crustaceous lichens, or overlaid with fine roots of epiphytic plants, the "bark" becomes thicker and more deeply fissured, leaving no doubt of a gradual renewal taking place where the surface is exposed.

The leaf-scars are difficult to detect on sections from the lower part of the trunk, but internodes 5-6 cm. long are indicated; on the fruiting section the internodes are reduced to 2.5 cm., the leaf-scars longer than the intervening zones, often attaining 2 cm., the scars not impressed or constricted, the surface somewhat uneven with scattered granules or tubercles where the fibers are attached (see pls. 10 and 12). Much longer internodes are indicated by photographs of *Plectis*, probably attaining 12 to 15 cm. (see pls. 20 and 21). Two or three consecutive joints bear inflorescences, with an interval of 3 or 4 barren joints before the inflorescences of the next season are developed.

#### CHARACTERS OF THE LEAVES

The leaf-crown of *Rooseveltia*, as shown in the photographs, is more ample than that of *Plectis*, and has a different aspect on account of the longer rachis and the more numerous and longer pinnae, and because the pinnae of *Plectis* droop from the rachis in a gradual curve. The rachis is held more erect or ascending in palms that stand in the open, shown in plates 1 and 19, instead of spreading or drooping, as in the more protected forest locations, plates 2 and 3. Although the leaf-blade is notably longer than in *Plectis*, about 4 m. instead of 3 m., the petiole is much shorter, 10-15 cm. instead of 35-45 cm., and the lowest pinnae are much closer together, only 3-6 cm. apart to 12-14 cm.

in *Plectis*. The pinnae number 73 on a side and attain 115 cm. in length near the middle of the leaf, compared with 63 pinnae in *Plectis*, 90 cm. long. The upper pinnae are reduced to 60 cm. in *Rooseveltia*, in *Plectis* to 37 cm.

The leaf-sheath is indurated and somewhat bulged in the middle of the lower part, extremely hard when dry, the outer surface nearly smooth, finely and irregularly striate, with the lines broadly and regularly sinuate near the base, thus affording space for the development of the young inflorescence, which apparently reaches nearly full size before the leaf falls. The remarkable thickening of the lowest joint of the peduncle may have a function in rupturing the base of the leaf-sheath at the proper time, although the sheath splits on the opposite side. Inner surface of sheath a much darker brown, deeply and coarsely striate when dry, also showing sinuate lines marking the courses of the fibers, but more prominent on the side supporting the petiole, there with 6 or 7 rows of fibers, distinctly coarser than those of the thinner sections; thickness of the middle section in the dry state attaining 5 mm., elsewhere about 1 mm. thick. The thickening of the sheath in the middle extends to the base, including the leaf-scar; length of leaf-scar below the thickened section usually about 1.5 cm., sometimes nearly 2 cm., about 1 cm. on the other side. The upper part of the leaf-sheath, the back of the petiole, and the lower part of the rachis with a distinct pale vitta nearly 2 cm. wide, of harder tissue and somewhat more prominent than the neighboring surface.

Petiole 4 cm. wide, deeply grooved, very densely beset with coarse rusty-brown scales on the upper side, underneath with only minute scattered brownish scales, the surface with rather thin, minute appressed tomentum, appearing silvery or glaucous. Considering the petiole morphologically as a naked basal section of the rachis, the length would be reduced by the pinnae extending lower down, and this is indicated by the lower part of the rachis being grooved in *Rooseveltia*, but nearly flat in *Plectis*.

Rachis measuring 343 cm. in the only complete specimen, broadly grooved at the base, nearly 4 cm. wide, narrowed gradually and thickened in the middle, the ridge widening and the lateral margins sharpening, soon forming a distinct lateral groove where the pinnae are inserted, the groove gradually wider and deeper, with the median ridge gradually narrowed and the lateral projection above the groove gradually suppressed, till only a thin median flange remains, rising about 1 cm. above the insertions of the pinnae. On the terminal third of the rachis the median flange is suppressed gradually, and the rachis

narrowed to 2 mm. near the end. Upper surface of rachis beset with coarse brown scales, the lower surface nearly naked, the scales minute and widely scattered.

Lowest pinnae 3-6 cm. apart, very narrow, 66 cm. long, 5-6 cm. wide, often splitting into 2-3 slender shreds; fourth pinnae 60 cm. long, 12 mm. wide; middle pinnae 115 cm. long, 4.5 cm. wide, with a prominent vein on each side 1-1.3 cm. from the midrib, usually more remote from the upper margins than from the lower, as 7 mm. to 4 mm. Three or four of the intervening venules larger than the others, but not regularly spaced, the finer venules very close; no indication of cross-veins. Upper pinnae 2.5-3 cm. apart, measured from the midveins. Pinnae with coarse brown scales underneath along the midveins, like the scales of the upper side of the rachis. Terminal pinnae very slender, 60 cm. long, 3 mm. wide, tapering to a long filiform point. The base of the rachis is shown in natural size at the left in plate 7, the pinnae on the left side torn off, and also the third pinna of the right side, but the attachment is perceptible as a narrow oblique scar near the middle of the section. Thus the narrow basal pinnae are nearly as close together as the pinnae at the middle of the leaf, shown in plate 8, in marked contrast with the lowest pinnae of *Plectis*, shown in the right-hand figure of plate 7.

#### STRUCTURE OF THE INFLORESCENCE

The inflorescences are similar to those of *Plectis* but relatively much shorter and more compact, attaining about 65 cm. instead of exceeding 1 m. as in *Plectis*, the peduncle and axis more reduced, the branches set closer, the flowers notably more crowded, too close for contiguous fruits to develop without contact, notably congested in the proximal portions of the lower branches instead of being farther apart as in *Plectis*; also the naked basal sections of the branches much shorter and more compressed than in *Plectis*, with a smaller and more specialized pulvinus. Surface of branches with a dense tomentum of stellate scales, notably coarser and thicker than in *Plectis*.

Spathes somewhat unequally developed, the lower spathe scar relatively narrow and superficial, the triangular lateral expansion of the scar much narrower than in *Plectis* and the projecting angle smaller. Inner spathe attaining a length of 85 cm., including a slender unopened tip 7 cm. long, 1.5 cm. wide at the base; width 5-6 cm., somewhat thickened at the sides but not distinctly carinate, the surface smooth but not shining, costulate along the fibers, and minutely striate, like an appressed tomentum; in the middle or lower part with scattering light-colored lacerate-stellate scales, more of the rays directed upward.

The peduncle is relatively smaller and more compressed than in *Plectis*, except the basal joint, which is strongly swollen and indurated, 3.5 cm. long in the middle, 6 cm. wide at the notches below the spathe scar, and 12-14 cm. wide across the basal rim that embraces and nearly encircles the trunk, the ends only 5-6 cm. apart; the line of attachment, where the fibers from the inflorescence enter the trunk, very narrow, only 4 mm. wide; lower face of joint abruptly swollen immediately below the spathe scar, whereas the lower joint of *Plectis* is only slightly and gradually swollen on the lower side, though distinctly swollen in the middle of the upper side. Second and third joints more abruptly reduced than in *Plectis*, though relatively longer, because the first joint is shortened; second joint more than half as long as the basal joint and nearly twice as long as the third joint, whereas in *Plectis* the first joint may be two or three times as long as the second, and the third joint nearly equal to the second. The entire inflorescence in flowering and fruiting stages shown in plate 13, figures *c*, *d*, *e* and *f*, with the remarkable enlarged basal joint, this also in natural size, with the basal joints of the axis in plates 11 and 12.

Axis much longer than the peduncle, though relatively short, from lowest to highest branch 27-29 cm., instead of 38 cm. in *Plectis*, closely beset with about 80 branches, not including those suppressed near the base, 18 on the upper side and 6 on the lower, or about 100 branch positions in all; the lower branches and branch positions subtended by short transverse bracts, much broader than long; bract of third joint 1.5 cm. long, 2.3 cm. wide; bract of first branch 5 mm. long, 1.8 cm. wide, other bracts 2 mm. long, 1 cm. wide, gradually smaller, these reduced bracts notably contrasting with the large linguiform bracts or secondary spathes that subtend the lower branches of *Plectis*, shown in plate 22. End of axis appreciably thicker than the branches, attaining 6 mm., the branches 5 mm. or less, gradually tapering to 3 mm. Naked base of branches attaining 3 cm. Lower branches attaining 57 cm. long, upper branches 43-45 cm. The male flowers are mature on the lower and middle sections of the branches soon after the inflorescence is exposed, but near the ends of the branches are many undeveloped flowers with the corolla not emerging beyond the calyx. A branch at the stage of flowering is shown in plate 14 at the left, cut in three sections, with many full-sized male buds still in place, but the flowers fallen, leaving many female buds standing alone, natural size; also detached male flowers and upper sections of a less-developed branch with the male flower-buds still in place. Lower sections of two mature fruit-bearing branches are shown in plate 16.



## FLOWERS AND FRUITS

Flowers in clusters of three, each cluster subtended by a broad lunate basal bract less developed than in *Plectis*, mostly covered with rather coarse tomentum of stellate scales like the surface of the branch, the margin of the bract usually naked, often sharply angled or apiculate in the middle; female flower enclosed by two large, broadly triangular longitudinal bracts, notably more prominent than the basal bract, slightly overlapping at the ends, forming a collar around the flower scar; one bract usually longer than the other, more distinctly angled at the apex and more carinate at the back, the margin often notched or fringed in the middle by the ends of parallel fibers like those of the sepals, outer surface of collar bracts with a rather sparse tomentum, shorter and finer than that of the basal bract; two male flowers above each female flower, the male flower scars usually circular, quadrate or oblong, usually separated from each other by less than their combined width, set close to the large collar bracts of the female flower but separated by a rim of dense tomentum doubtless representing a very short pedicel; one of the male flowers more distinctly pedicellate than the other, and the scar somewhat smaller; the small bracts that subtend the male flowers decurrent between the upper extremities of the basal bract, often sharply angled. The collar bracts are distinctly accrescent, growing much larger where fruits are developed, sometimes nearly 2 mm., or nearly half the length of the sepals, in section through the middle thicker than the sepals or the petals; of the same brownish or purplish color as the perianth and the neighboring tomentum, possibly stained from the ripe fruits. Scars of female flowers and ripe fruits are shown in great numbers in plates 16 and 17.

Male flowers 6 mm. long, the calyx triangular, the sepals broadly overlapping, 3 mm. long, thickened in the middle and often distinctly carinate, the prominence usually ending abruptly below the angular apex; margins on each side minutely fringed. Petals narrowly triangular, 5 mm. long, 2 mm. wide at base, rather irregularly costate-striate on the inside, with a rounded basal pulvinus nearly 2 mm. long, fused with the large staminal cushion filling the lower third of the flower.

Stamens 6, not exerted, the filaments rather robust, subconic, of firm, fleshy texture, 3.5 mm. long, broadened at base to nearly 1 mm. and somewhat united, forming a low ring on the staminal cushion; filaments incurved at base, above gradually recurved, especially those alternate with the petals; end of filament subtruncate, the attachment

at one side. Anthers introrse, oblong, slightly tapering, 2-2.5 mm. long, the narrow subversatile attachment a little above the middle, the dark connective exposed at the back, nearly as long as the pale closely contiguous anther-cells. Pistillodes nearly 3 mm. long, conic-cylindric, assimilated to the filaments in form, texture, and color, thickened and somewhat united at the base, not flattened or much united as in *Catis* or *Acrista*.

Female flowers with sepals and petals of the same texture and form, broadly obovate-triangular, the distal margin often transverse or retuse, but distinctly mucronate in the middle, the mucro thickened and the median area prominent, with numerous parallel longitudinal fibers, the marginal band very thin and transparent, often lacerate-fimbriate. Petals in the bud enclosed by the sepals, but strongly accrescent, at maturity about one-third longer than the sepals, covering the lower third of the fruit, the mature perianth brownish, tinged with dull crimson-purple along the margins. Staminodes obsolete, lacking even the thin rudiments sometimes found in *Plectis*.

Fruits somewhat larger than in *Plectis*, subglobose, nearly 1 cm. in diameter; style and stigma subapical, persistent, borne on a prominent indurated frustum, surface more coarsely granular than in *Plectis*; the outer crust thicker and harder, formed of large accretions of stone-cells; mesocarp fibers few, though stronger and more irregular than in *Plectis*. Not only the style and stigma are thicker and more persistent than in *Plectis* but the supporting frustum is more prominent and much more indurated, the difference in texture being indicated by a dull yellowish color, instead of purplish like the surface elsewhere. The frustum in *Plectis* is somewhat less prominent, and only the rim is indurated and of a lighter, yellowish color, along the upper margin; also the induration is less in *Plectis* and the disk nearly flat, the style not being thickened, and the base relatively narrow and abrupt.

#### SEEDS AND SEEDLINGS

Seeds globose-reniform, with uniform endosperm, basal embryo and subapical hilum, the upper surface somewhat flattened, a broad shallow groove between the hilum and the embryo; the upper margin of the groove around the hilum somewhat prominent or inflated, more than in *Plectis*, also the groove broader and more sloping on the sides, the raphe or downward extension of the hilum much narrower than the groove, with distinct margins tapering gradually to a point about halfway to the embryo; the groove mostly occupied by a strand of parallel fine fibers, radially diverging under the embryo; the outer

layer of fibers much more irregular than in *Plectis*, some rather broad and flat, the inner layer also somewhat less regular, the lining membrane very thin, closely adhering around the seed, with the finer fibers impressing the surface of the testa. In *Plectis* the raphe is broader and longer, extending to near the embryo, and the fibers are free from the testa, leaving the surface clean and only faintly impressed with fine parallel lines.

Seedlings like those of *Plectis*, but more slender and delicate; first expanded leaf with 6 separate segments, the rachis 1.2 cm. long, uniting the middle segments for 8 mm.; second leaf and at least three others with only 4 segments, 2 on each side; sometimes remaining adherent on one or both sides; the segments somewhat more slender and grasslike than those of *Plectis*. Segments of first leaf 6.5 cm. by 3.5 mm., widest below the middle, tapering gradually; mid-vein and submarginal veins distinct, with 3-4 venules between; margins distinctly thickened.

Seedling internodes very short, only 1 to 2 mm., with 2 or 3 roots emerging from each joint, either from the leaf-scars or from the intervening surface; roots 1-2 mm. in diameter, attaining 15-30 cm., tapering gradually, branching irregularly, often with fine ramifications near the base; roots very stiff and wiry, often injured at the sockets, so that transplanting may be difficult, as indicated by the survival of only two of those brought home by Dr. Schmitt. These individuals were among the smallest obtained.

Sheaths and petioles of seedling leaves very long, no doubt an advantage in reaching more light; second bladeless sheath 4 cm., sheath of first expanded leaf 5 cm., increasing to 15 cm. on the next 4 or 5 leaves, the filiform petioles as long as or longer than the sheaths, and the segments nearly as long, so that a height of half a meter is reached before the trunk is a centimeter long or a centimeter thick. Much longer petioles, probably a meter or more, are shown in the photograph of young palms or offshoots growing in the forest (pl. 3), in striking contrast with the very short petioles at the adult stage. Compared with the seedling leaves of *Plectis*, the sheaths are longer and the petioles relatively shorter, in agreement with the proportions of the adult palms. The rim of the sheath, opposite the insertion of the petiole, even on the lower leaves, is not transverse, but has an upward projection or antiligule 1-2 cm. long, indicating that this structure is a general feature of the palm.

The seeds began to germinate in a few weeks, and by the middle of April 1939, many of the seedlings had expanded the first 2 leaves,

showing a remarkable regularity in the 6 pinnae of the first leaf-blade, with fewer pinnae and the number less regular on the second leaf. The antiligule is a constant feature, even on the first leaf, triangular and sharp-pointed, 5 to 7 mm. long, of very thin texture and soon turning brown like the tips of the bladeless sheaths. The first sheath, about 1 cm. long, has little chlorophyll and soon dies, the second sheath, 4-5 cm. long, being more persistent. The surfaces of the seedling, including the bladeless sheaths, midribs, veins and margins of leaves, are moderately beset with reddish-brown scales, more abundant near the base and the tip of the leaf-segments than in the middle. The outer sheath rises from a shallow cup, about 2 mm. high, like that figured by Martius as the coleoptile of *Euterpe oleracea*, the Brazilian *assai* palm now called *Catis martiana*. This organ is an outgrowth of the cotyledon, not a part of the plumule, and lacks the longitudinal fibers that give the sheaths a ribbed appearance in drying. A single primary root usually is surmounted by a single secondary, close to the coleoptile, which splits on that side. The roots are very slender and wiry, with many contorted lateral rootlets and adherent patches of a dark-brown membrane, suggesting an early surface layer that exuviates.

#### CONTRASTING FEATURES

The outstanding differences are the columnar, short-jointed trunk, abruptly thickened at the base; the thicker, more indurated leaf-sheaths; the large fibrous antiligule; the short, densely squamous petiole; the long rachis with numerous close-set pendent pinnae; the more compact and shorter inflorescence, with the basal joint strongly crassate and expanded to encircle the trunk; the close-set branches, subtended by small bracts; the crustaceous exocarp with the style persistent, and mounted on a broad indurated frustum; the irregular mesocarp fibers; and the broadly grooved seed, with a narrow short raphe.

The relative absence of a petiole in the adult stage of *Rooseveltia*, the more compact and shorter inflorescences, and the harder shell of the fruits, in comparison with *Plectis*, may be taken to indicate less definite specialization as a forest palm, and better adaptation to open conditions than related palms that are natives of heavily forested regions on the continent. The island flora is very limited, of course, in comparison with that of the continent, including only a few kinds of trees, and these doubtless recruited gradually, so that in former times the palms may have had much more open conditions than in the recent period.

The branches of the inflorescence are set too close along the axis to afford space for thickened bulbous bases and swollen pulvini like those of *Plectis*, which stand much wider apart. There is only a short abrupt basal widening of the branches in *Rooseveltia*, and this notably flattened, with thin angular margins; the pulvinus also is more reduced, in the dry state appearing as a small corneous prominence, rather than broad, woody and persistent as in *Plectis*.

As a consequence of the flower-groups being set more closely along the branches the positions of the male flowers are somewhat different from those of *Plectis*, the male buds not lying so flat against the branches, as shown by the long impressions above the female flowers. With the male buds more perpendicular to the branches, the bud-scars are not so much sloped or tilted against the base of the female flower, and hence appear more distinct in the photographs than do those of *Plectis*. Also the more upright position of many of the male flower-buds is shown in the natural-size photograph of inflorescence branches at the early flowering stage (pl. 14).

**ROOSEVELTIA FRANKLINIANA,<sup>4</sup> n. gen. and sp.**

Plates 1-19

*Diagnostic characters.*—Agreement in many characters shows close affinities with *Plectis*, but the trunk more robust and columnar, abruptly thickened at the base, not forming aerial roots; internodes short, much broader than long; leaf-sheaths indurated at the base on the axial side; rim of leaf-sheath fibrous, produced in the middle, opposite the petiole, into a long fibrous antiligule; petiole very short, densely squamous; rachis very long, the pinnae more numerous, very long and pendent, the lower pinnae adjacent; inflorescence shorter and more compact, with more numerous close-set branches, the peduncle very short, the basal joint indurate, crassate and inflated; numerous lower branches suppressed on the upper side of the axis and several on the lower side; branches and branch positions subtended by short, transverse, rudimentary bracts; branches with a short, naked base slightly inflated at the insertion; surface of branches densely tomen-

<sup>4</sup> ROOSEVELTIA genus novum, *Rooseveltia frankliniana* species typica, palma spectabilis formosa, insulae nuncupatae "Cocos" indigena, ad Plectina "halaute" Guatemalensium proxima, trunco valido columnari crebricincto, antiligula ampla fibrosa, petiolo perbrevis supra dense squamoso, pinnis permultis approximatis praelongis pendentibus, spadice compacta, floribus congestis, baccis grumosis, \*eminibus late impressis recedit. Typus, *Schmitt* 134 (U. S. Nat. Herb. 1,740,833—841).

tose; flower-clusters closely crowded on the branches, especially on the lower sections of the basal branches; basal bract of flower-clusters moderately developed, notably less prominent than the collar bracts; male flower-scars often oblong quadrate or rounded, margined or winged with tomentum especially on the mesial side, the pedicel reduced to a thin disk, but sometimes distinct; fruits with an indurated discoid frustum bearing the persistent indurated style and stigmas; pericarp granular-tuberculate on the surface, hard and crustaceous in texture, with irregular granules like stone-cells; mesocarp fibers flexuous and variable in size, forming a rather irregular network; seed distinctly flattened on the upper face, a broad gradually sloping groove between the hilum and the embryo, and a short, narrow raphe, extending about halfway to the embryo.

#### DESCRIPTION OF PLECTIS OWENIANA COOK<sup>5</sup>

Plates 4, 7, 20-26

Trunk smooth, ringed with leaf scars, attaining 25 m. in height, 68 cm. in circumference at base, 50 cm. at one meter above the base, 27.5 cm. at the top; trunk supported on a conical mass of thick tuberculate roots 7.5 cm. in circumference, with large fibrous root-caps; sometimes with aerial roots growing from higher internodes, to a meter above the surface, forming props around the trunk as in the stilt-palms, *Iriartea* and related genera. The special development of aerial roots may be an adaptive character for growing on massive limestone formations.

Leaf-sheath bundle 150 cm. long, 27.5 cm. in circumference near the top; margin of the sheath thin and friable, a projection or antilugule about 6 cm. long opposite the petiole, of fleshy or membranous texture, not fibrous, fragile when dry, about 6 cm. long, 5 cm. broad. Texture of leaf-sheaths thin, with a delicate lining that separates readily; petiole 37-47 cm. long, nearly 4 cm. wide near the base, 3 cm. below the first pinnae, broadly grooved in the lower part, nearly flat above, the upper surface with scattered minute fugacious scales.

Rachis 267 cm. to the insertion of last pinna, 27 cm. wide near the base, the upper surface nearly flat, gradually becoming ridged and triangular in cross-section, flat underneath, tapering from 8 mm. wide to only 2 mm. near the end, continued as a slender fiber as long as the last pinnae. Surface of rachis with scattered fine scales, larger and more abundant on a small oblique area below the insertion of the pinna

<sup>5</sup> Bulletin of the Torrey Botanical Club, vol. 31, p. 353, June 1904.

and also on the base of the pinna, the scales flat and rather regular in outline, often split or notched along the margins, but not rayed or fringed; lower part of rachis surface naked.

Pinnæ 61-63 on each side, lower pinnæ widely spaced, 12-14 cm. apart, the middle and upper pinnæ closer and more regular, about 4 cm. apart; basal pinnæ 67 cm. by 1.1 cm.; middle pinnæ 81-93 cm. by 3.5 cm.; terminal pinnæ 37 cm. by 1.2 cm. or less, often split into narrow shreds, 5 mm. or less in width. Upper pinnæ with coarse brown scales on a short basal section of the midrib underneath, the scales possibly fugacious elsewhere. Secondary veins distinct, but less prominent than in *Rooseveltia*.

Outer spathe longer than the inner, attaining 130 cm., broadly auricled at base, 15 cm. broad across the auricles, 10 cm. broad above the auricles, gradually wider above, the lateral margins winged, the tip thin and flat, 4 cm. wide near the end. Auricles of the first spathe supported on the widened basal joint of the peduncle, the lateral expansion of the spathe-scar measuring 2.5 by 1.5 cm., but the scar only 2 mm. wide near the median line. Scar of second spathe 6 mm. wide on the sides, 3 mm. near the middle. The two spathes similar in size and texture, thin and friable when dry like the leaf sheaths, not woody and rigid as in some of the related genera that have unequal spathes, only the inner spathe complete, the outer much shorter. A similar specialization, two complete spathes of thin texture, and these retained in the leaf-sheaths till the time of flowering, appears in several East Indian palms, *Seaforthia*, *Loroma*, *Archontophoenix*, and *Linoma*.

Spadix, including the very long, slender subequal branches, exceeding 1 m.; peduncle to first branch 9-13 cm., basal joint 5-9 cm., second joint 2.2-2.5 cm., third joint slightly shorter than the second. Branching axis 37-39 cm., with 65-70 branches; tip of axis beyond branches 66 cm.; several branches (7-9) suppressed on the upper side of the lower part of the axis, none on the under side; the lower branches and locations of suppressed branches subtended by large rusty-brown spathe-like bracts, attaining 22 cm. by 4 cm. Lower branches 60-70, long, the naked base or stalk attaining 6 cm., gradually shorter, 2-4 cm., on upper branches; distal sections of branches tapering, the terminal 5-6 cm. with only male flowers. Lower branches often with a rounded dark-colored pulvinus above the lowest flower-cluster or flower position, doubtless a carry-over from the pulvini in the axils of the branches.

Flower-clusters rather remote in the lower sections of the branches, then gradually closer, though not crowded as in *Rooseveltia*, the middle and upper sections becoming distinctly notched and flexuous on account of the deep depressions formed by the male flower-buds; male flower-scars usually transverse or triangular, surrounded by a narrow rim of compact tomentum, one of the pair often distinctly pedicellate at least on the lower part of the branches.

Female flowers with sepals 3 mm. by 4 mm.; petals subquadrate, 5 mm. long, subtended by two broadly triangular erect bracts, often distinctly carinate on the outside, often exceeding 1 mm. in height. Staminodes sometimes distinct, at least the outer 3, those alternating with the petals minute and membranous or somewhat indurated.

Fruits broadly conic-ovoid, with a prominent subapical stigma-scar or slender shriveled style, surrounded by a low flattened frustum: surface nearly smooth, the exocarp thin, firmly fleshy; mesocarp fibrous in two layers, an outer coat of brown interlaced and anastomosing fibers and an inner coat of much finer pale-yellowish fibers, subequal and parallel, imbedded in a rather firm fleshy membrane, the surface of the testa only faintly impressed.

Seeds reniform-globose, with uniform endosperm, basal embryo and subapical hilum, a broad abrupt groove between the hilum and the embryo, mostly occupied by the broad raphe decurrent from the hilum to near the embryo.

Seedlings with the first leaf compound, of 3 pinnae on each side followed by at least 3 leaves with only 2 pinnae on a side, sheaths of seedling leaves 6-7 cm. long, petioles to 19 cm.

The original specimens of *Plectis oaxeniana*, the type of the genus, were collected in Alta Vera Paz, Guatemala, northwest of Panzos, near the Finca Sepacuité, between Senahú and Cajabón, March 1902.

The very large bracts or supplementary spathes subtending the lower branches of the inflorescences and marking the locations of suppressed branches are a notable example of the retention of a primitive feature that in *Rooseveltia* and most of the other related forms are reduced to mere rudiments. The spathes undoubtedly are homologous with the bracts that subtend the branches, some of the primitive palms having compound inflorescences with spathes developed at each branch, and all the spathes nearly equal, instead of the basal spathes being largely developed and the others suppressed. The original protective function having passed entirely to the large basal spathes and the leaf-sheaths, it is difficult to imagine that the large bracts of *Plectis* are of any use, though of scientific interest as marking a stage



of gradual suppression. In retaining the large bracts, *Plectis* may be considered as less specialized, and also in having the two large basal spathes nearly equal, the first somewhat larger than the second, the usual relation being that the first or outer spathe is much shorter, with the inner spathe emerging at a relatively early stage of development, and becoming much firmer in texture than the outer spathe.

Each of the flower clusters is subtended by a bract, as though representing a shortened branch of a primitive compound inflorescence, and four other bracts are represented in each flower cluster, one on each side of the female flower, usually overlapping at the ends, forming an upright persistent collar around the base of the flower. Outside the collar bracts are two others, much smaller, each subtending a male flower, these male bracts decurrent between the collar bracts and the upward extensions of the basal bract, at the sides of the female flower. The basal bract is nearly as prominent as the collar bracts and often distinctly apiculate. The collar bracts are angled or broadly rounded, somewhat carinate at the back, and thickened with parallel fibrovascular ribs like the basal bract and the calyx, though less so than in *Rooseveltia*. Surface of basal bracts and also of collar bracts covered with short tomentum like that of the branches. This functional involucre in *Plectis* and related genera is in contrast with *Acrista* and *Orcodoxa*, which have the bracts minute and rudimentary, buried under the flowers in the depressions of the thickened branches.

Small off-shoots are formed on young palms, as shown in the photograph, though under forest conditions only one trunk is developed from a cluster of roots. On a cut or injured trunk another off-shoot may develop, as observed in several cases where roads or temporary clearings had been made through forest areas.

The fact that all the young palms are much more slender than the mature individuals leaves no doubt that a gradual thickening of the trunk takes place during development, although the surface is nearly smooth and evidences of enlargement were not obvious on the largest palms, that may have attained the full diameter. On palms of medium size, a more rapid thickening may take place, and longitudinal fissures of the outside layer were in evidence, although the surface is kept nearly even by the furrows filling with a new growth of brownish, barklike, corky material. Also it was noticed that a rather soft outer layer could be distinguished, with fibers much smaller than those of the harder "wood" underneath. By a gradual addition of fibers on the outside, fine at first and gradually thickened, a form of exogenous growth seems possible.

A large individual, about 25 m. tall, in the forest near Sepacuité, was cut in 1902 but remained upright, held by vines that bound it to an adjacent large tree, and was still alive in 1904, with the leaf-crown still fresh. That the moisture stored in the trunk had been sufficient to support the crown is difficult to believe, and raises the question of the leaf-crown absorbing water or of a few fibers near the center of the trunk remaining uncut and continuing to function for a time. It is known that trunks of other palms continue to exude sap at the upper end for several months after being felled, as in the "molasses palm" of Chile, *Jubaca chilensis* (Molina), and the humid forest conditions doubtless would lengthen the period of continuing to furnish moisture.



SHORE OF COCOS ISLAND AT CHATHAM BAY, WITH ROOSEVELTIA  
PALMS EMERGING ABOVE THE FOREST



1. A leaf-crown of a palm standing in the forest.



2. Leaf crown of felled palm, stood up to show leaf-sheath, the very short petioles and the close-set lower pinnae.

FOLIAGE OF ROOSEVELTIA, GROWN UNDER FOREST CONDITIONS,  
WITH SPREADING LEAVES AND NUMEROUS DROOPING PINNAE



1. Foliage and habits of growth



2. Base of mature palm-trunk overgrown with epiphytes of the Bromelia family. At right of trunk slender leaves of palm off-shoots, with long petioles.



1. Base of a *Rooseveltia* palm and large offshoot, growing on a steep slope, the roots exposed on the lower side.

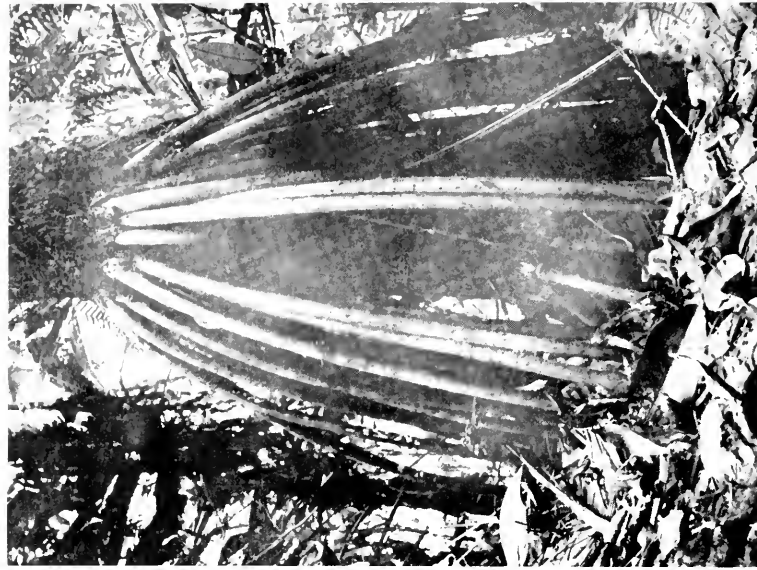

2. Aerial roots of *Plectis occidentalis*, Alta Vera Paz, Guatemala.



1. Outer surface of mature trunk near the base, the thin surface layer with fine longitudinal grooves less distinct above than where the surface was protected by the crustaceous lichens, the "bark" broken in the lower part showing the smooth subsurface layer. (Natural size.)



2. Longitudinal sections of the trunk, at the right a radial section showing fine fibers near the surface and coarse compact fibers underneath; left-hand section with finer fibers, farther up the trunk. (Natural size.)

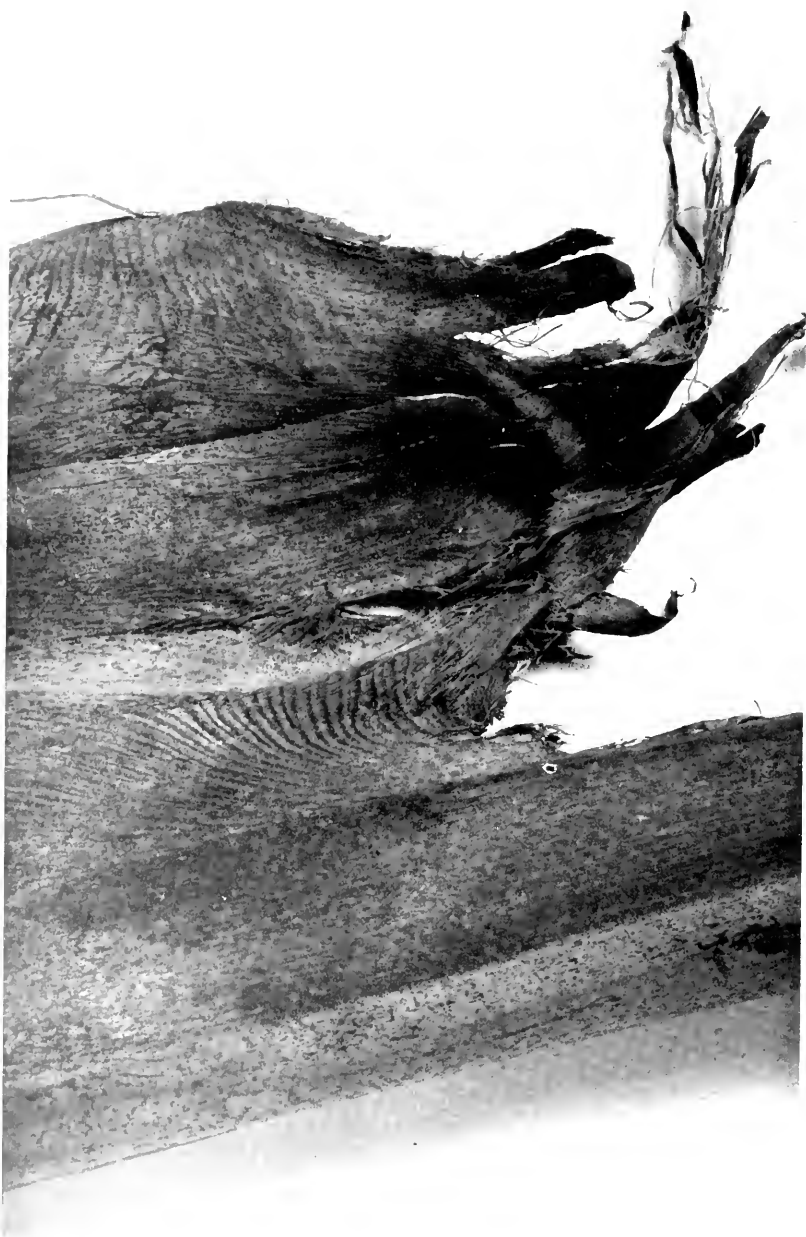

Mouth of leaf-sheath and base of petiole, the leaf-sheath opened and flattened, showing the antiligule as a large fibrous expansion of the sheath beyond the attachment of the petiole. Also the light-colored vitta at the back of the petiole is distinctly shown. (Natural size.)

ANTILIGULE OF ROOSEVELTIA





1. *Rooseveltia*, basal section of the rachis showing insertions of 5 pinnae, the middle pinna lost, but the scar perceptible.

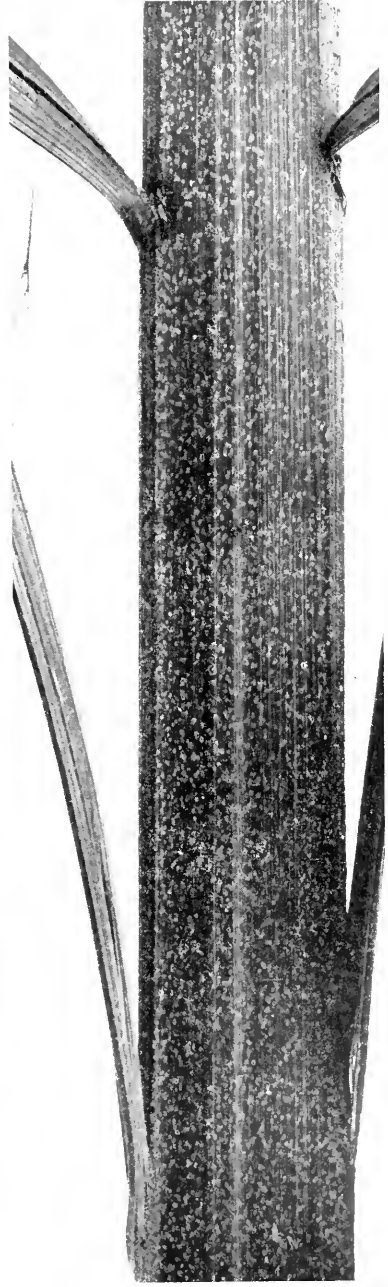

2. *Plectis*, lower section of rachis with only 2 pinnae on each side, widely separated. (Natural size.)



1. Section near the middle of the leaf, showing the rachis with a high median flange above the insertion of the pinnae.



2. Terminal section of the rachis, to insertion of last pinnae, the upper surface of rachis beset with brown scales. (Natural size.)

RACHIS OF ROOSEVELTIA



LEAF OF ROOSEVELTIA, MIDDLE SECTION, SHOWING REGULAR  
INSERTION OF VERY LONG PENDENT PINNAE



YOUNG INFLORESCENCE OF ROOSEVELTIA

Section of the spathe and first joint of peduncle, seen from the side, showing the lateral expansion that nearly encircles the trunk. Also note striate surface of young leaf-sheath, unevenly beset with small brown scales.

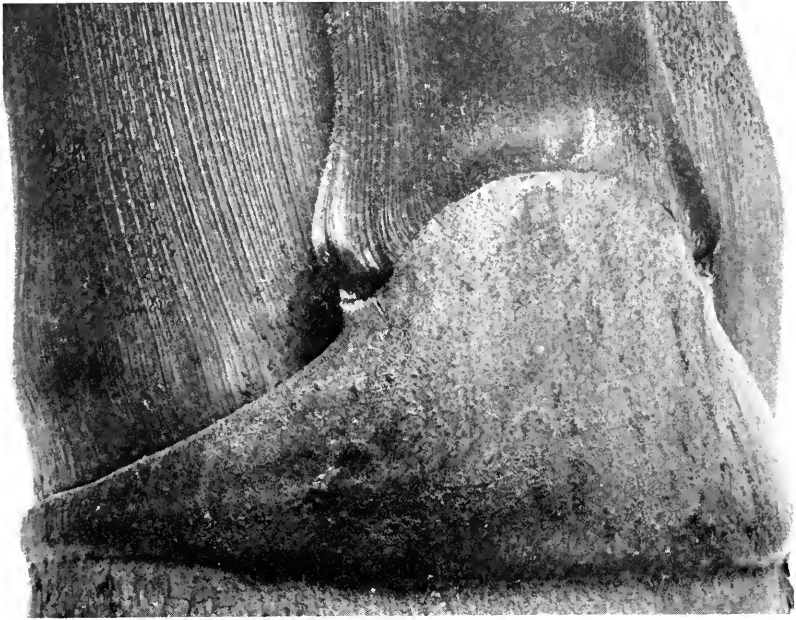

1. Base of young inflorescence.

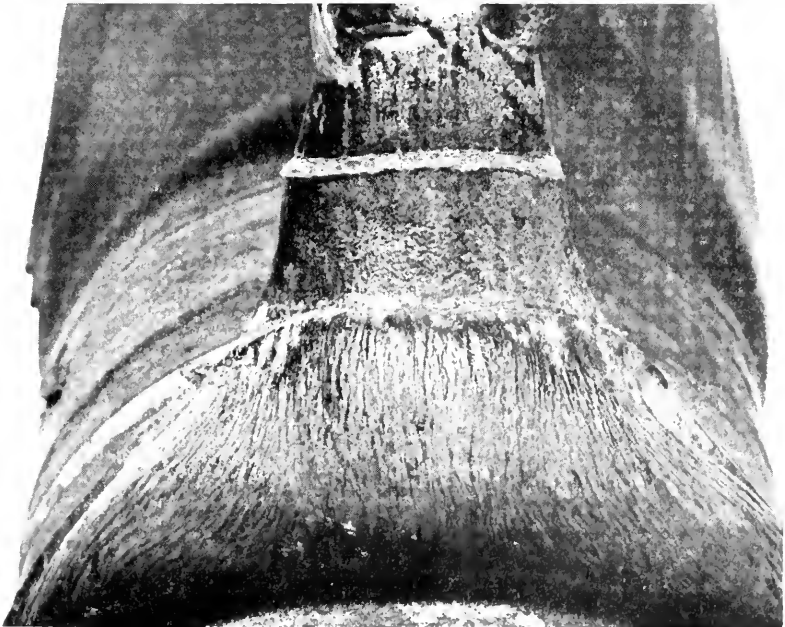

2. Base of mature inflorescence. (Nearly natural size.)

**ROOSEVELTIA, BASAL JOINT OF PEDUNCLE**

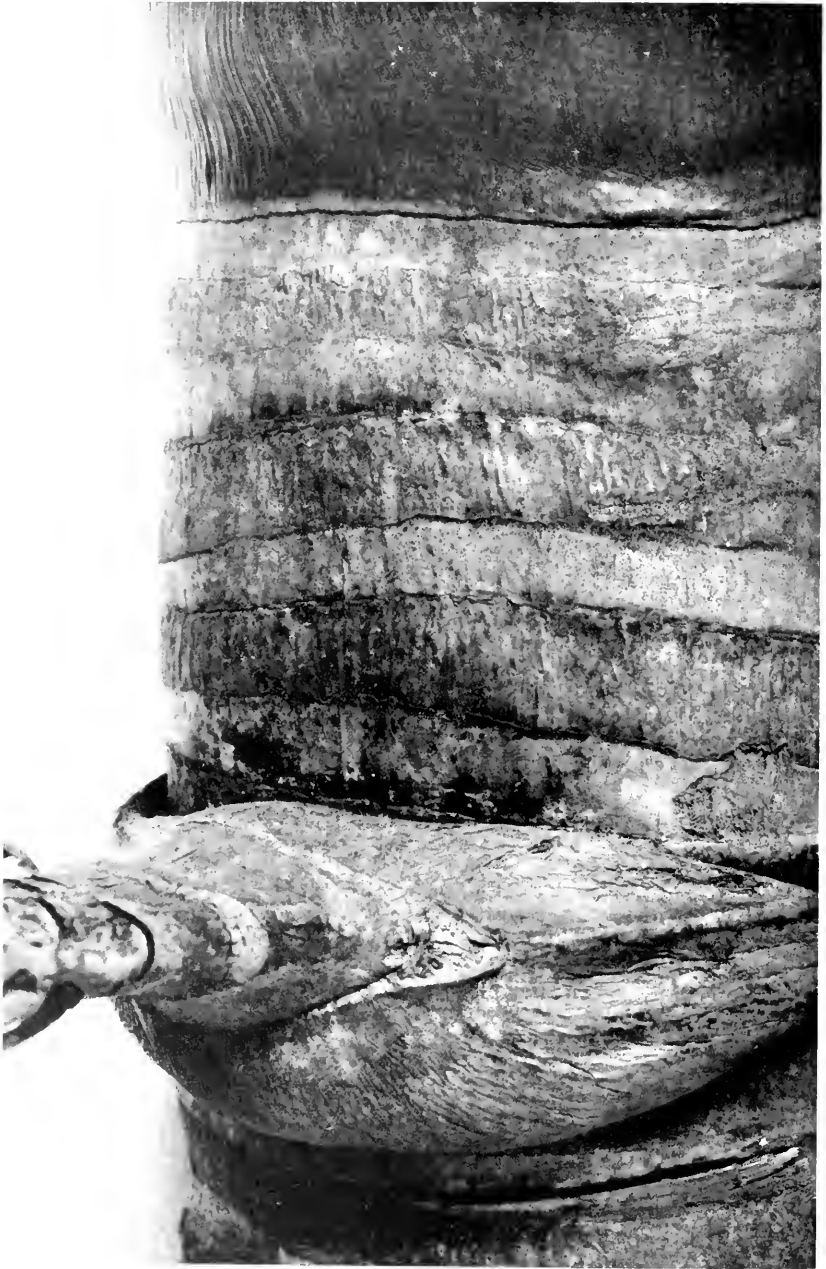

**ROOSEVELTIA TRUNK AND INFLORESCENCE**

Summit of trunk, base of mature, indurated leaf-sheath, short trunk-zones and longer leaf-scars, with basal joints of mature inflorescence. (Natural size.)



a



b



c



d



e



f

## COCONUT PALMS AND ROOSEVELTIA

a, coconut palms at Wafer Bay, Cocos Island, to compare with b; b, leaf-crown of *Rooseveltia*, showing similar leaf-form and drooping pinnae; c, d, young inflorescence of *Rooseveltia* at the opening of the male flowers; e, f, mature inflorescence of *Rooseveltia*, viewed from the side and underneath, showing the greatly swollen basal joint of the peduncle and the ripe fruits.

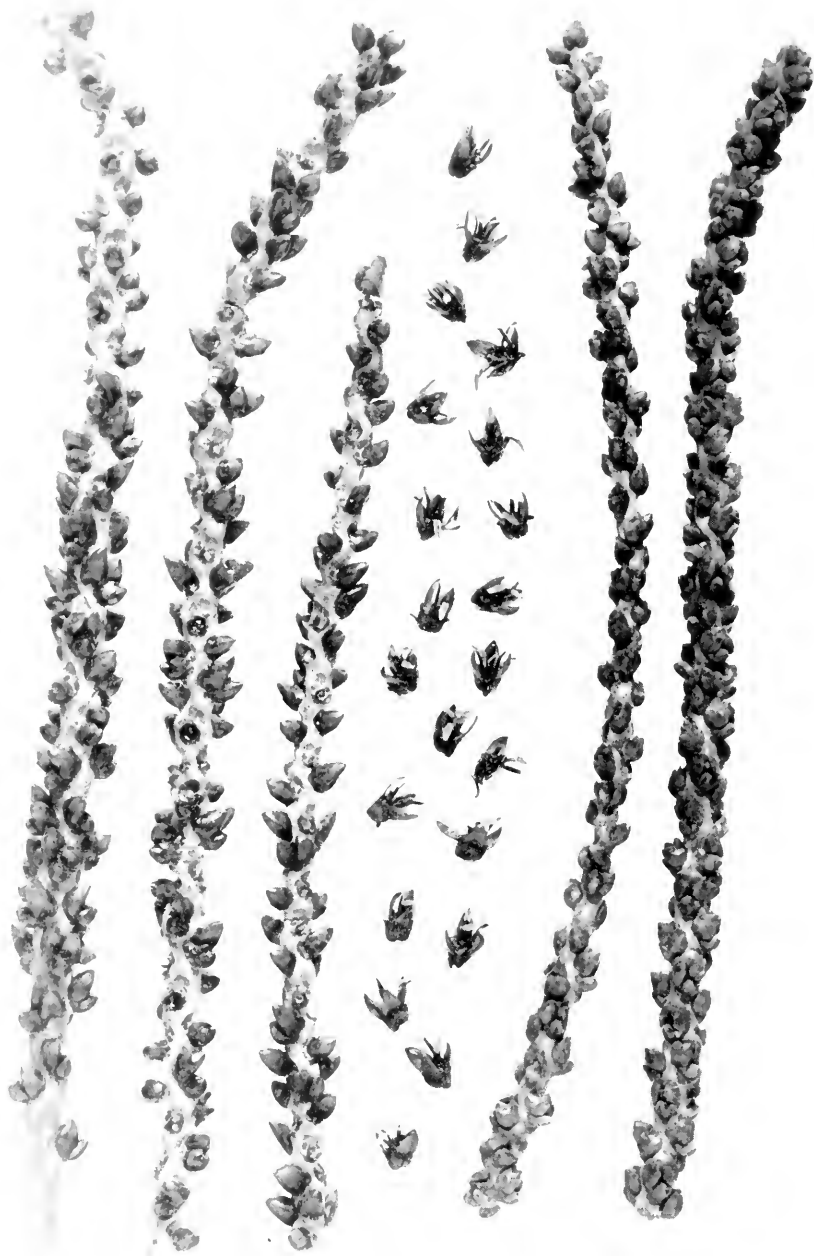
**ROOSEVELTIA BUDS AND FLOWERS**

At the left a complete flower-branch cut in three sections, many large conical male buds still in place but the flowers detached. At the right terminal and basal sections of branch with younger buds, showing clusters of two males and one female flower still in place. (Natural size.)



**ROOSEVELTIA MALE FLOWERS**

Showing short overlapping sepals, large valvate petals, fleshy recurved, truncate filaments, oblong-triangular anthers, and divaricate pistillodes. (Enlarged about 7 diameters.)



1. Basal sections of inflorescence branches with mature fruits. (Natural size.)



2. Basal section of mature inflorescence, showing insertion of branches along the axis and suppression of branches on upper face. (Natural size.)

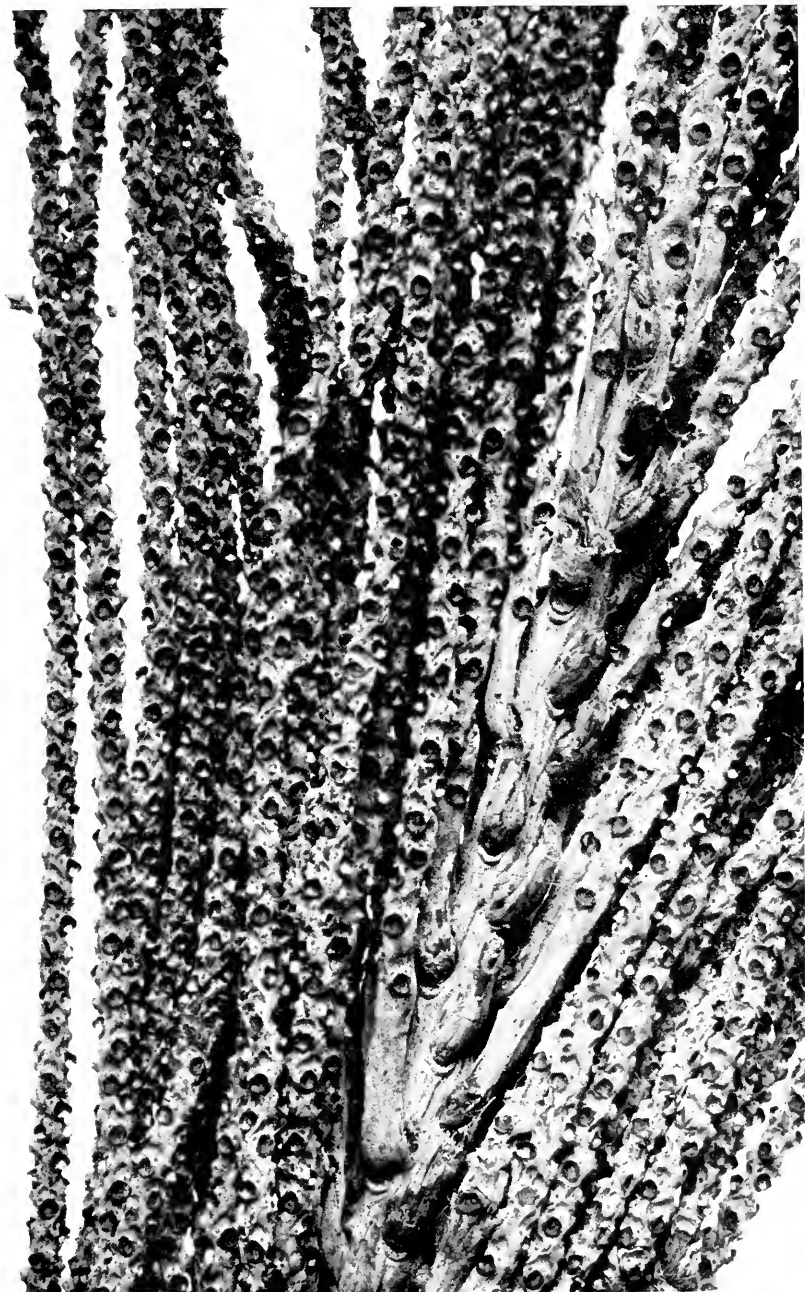

BRANCHING OF ROOSEVELTIA INFLORESCENCE

Several branches removed to show close insertion of branches and end of branching axis somewhat thicker than the branches. (Natural size.)



## SEEDLING STAGE OF ROOSEVELTIA

Seedling with first expanded leaf showing 6 radiating grasslike segments; base of older seedling right, showing long sheaths and petioles; leaf of still older seedling at left; to compare with seedlings of *Plectis*, plate 24. (Natural size.)



1. Palms in exposed location, the leaves held more upright than in the forest.



2. An entire leaf-blade of *Rooseveltia*, with veterans of the palm excursion.

**ROOSEVELTIA AT COCOS ISLAND**



PLECTIS PALMS EMERGING ABOVE THE FOREST, ON THE SUMMITS OF  
LIMESTONE MOUNTAINS IN THE DEPARTMENT OF ALTA  
VERA PAZ, IN EASTERN GUATEMALA



MATURE INFLORESCENCE OF PLECTIS

Upper joints of trunk and portion of leaf-sheath showing very long slender branches, to compare with more compact inflorescence of *Rooseveltia*, plate 13.

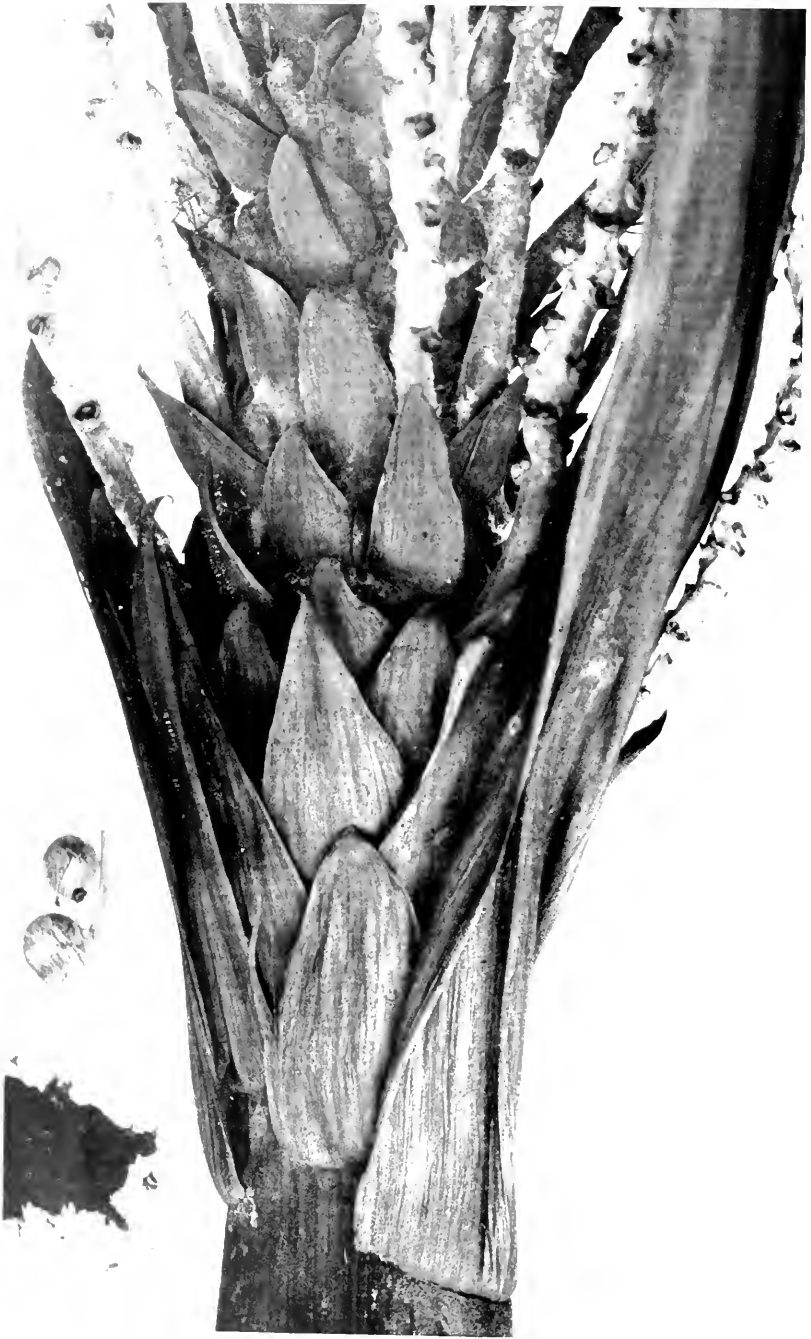

YOUNG INFLORESCENCE OF PLECTIS PALM

Upper part of peduncle and lower section of branching axis, showing large spathe-like bracts subtending branches and locations where branches are suppressed. At the left a naked seed and a seed with fibrous covering, beginning to germinate. (Natural size.)





PEDUNCLE AND FRUITS OF PLECTIS PALM

With lower section of branching axis, showing long naked base of branches with pulvini at the insertions, also section of a branch with mature fruits. (Natural size.)

**SEEDLINGS OF PLECTIS PALM**

Seeds with fibrous covering, at different stages of germination, the first expanded leaf with 6 segments, the second leaf with 4 segments; 2 bladeless sheaths preceding the leaves. (Natural size.)

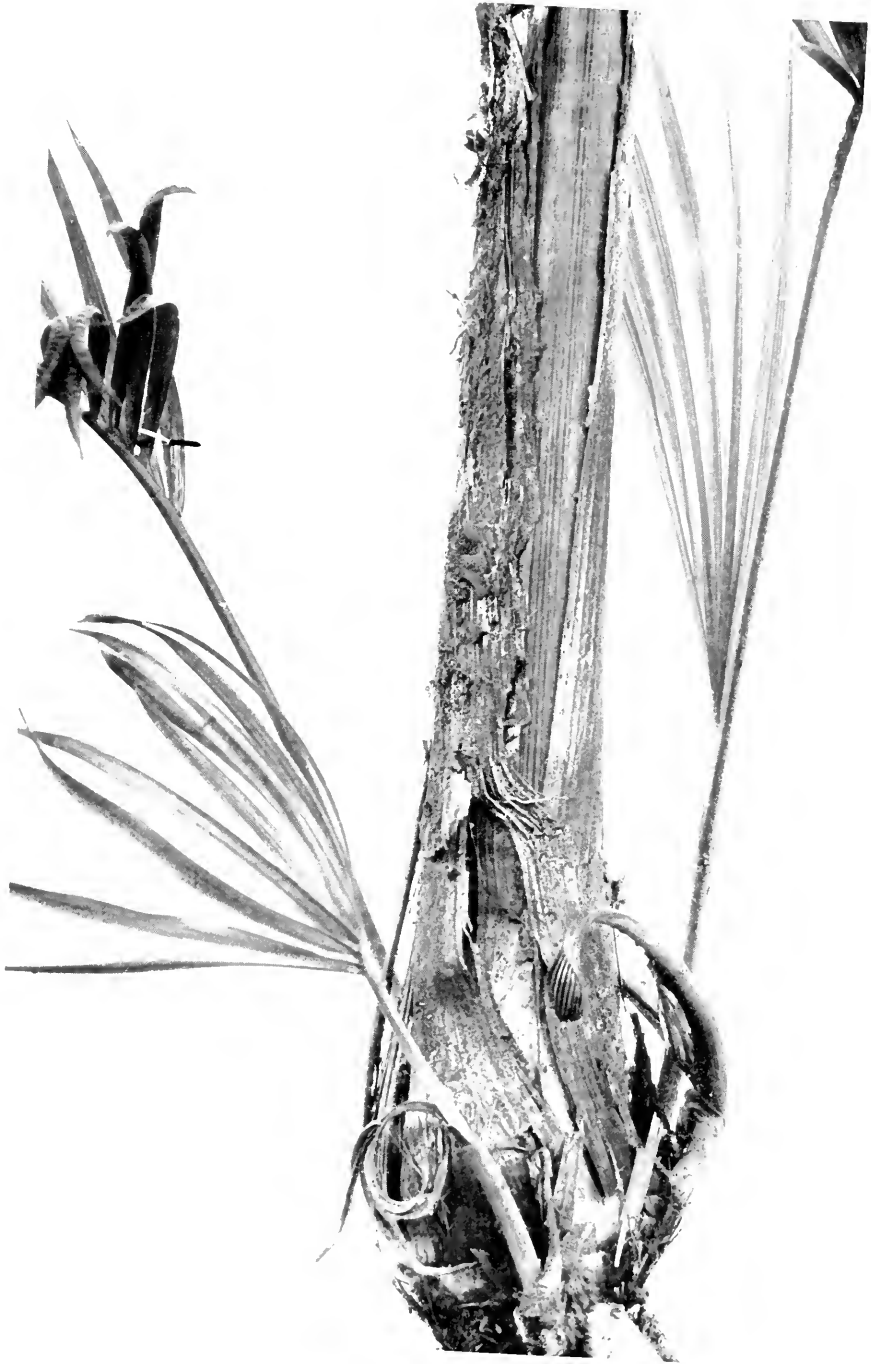

**OFF-SHOOTS OF PLECTIS PALM**

A large off-shoot giving rise to 4 much smaller off-shoots, with narrow grass-like leaf-segments like those of seedlings, but more numerous. (Natural size.)



FOLIAGE OF PLECTIS PALM

Upper section of trunk, leaf-sheath bundle, and part of leaf-crown, brought out of forest to photograph, at Finca Sepacuité, in the district of Panzos, showing long petioles and widely spaced sloping pinnae, in comparison with *Rooseveltia*, plate 2.

SMITHSONIAN MISCELLANEOUS COLLECTIONS  
VOLUME 98, NUMBER 8

FLOWERING PLANTS COLLECTED  
ON THE PRESIDENTIAL CRUISE  
OF 1938

BY  
ELLSWORTH P. KILLIP  
Associate Curator, Division of Plants,  
U. S. National Museum

1939



(PUBLICATION 3533)

CITY OF WASHINGTON  
PUBLISHED BY THE SMITHSONIAN INSTITUTION  
MAY 27, 1939



SMITHSONIAN MISCELLANEOUS COLLECTIONS  
VOLUME 98, NUMBER 8

FLOWERING PLANTS COLLECTED  
ON THE PRESIDENTIAL CRUISE  
OF 1938

BY  
ELLSWORTH P. KILLIP  
Associate Curator, Division of Plants,  
U. S. National Museum



(PUBLICATION 3533)

CITY OF WASHINGTON  
PUBLISHED BY THE SMITHSONIAN INSTITUTION  
MAY 27, 1939

The Lord Baltimore Press  
BALTIMORE, MD., U. S. A.



FLOWERING PLANTS COLLECTED ON THE  
PRESIDENTIAL CRUISE OF 1938

By ELLSWORTH P. KILLIP

*Associate Curator, Division of Plants, U. S. National Museum*

The flowering plants collected by Dr. Waldo L. Schmitt on the Presidential Cruise of 1938 are enumerated herewith, with the exception of a new palm, described by Dr. O. F. Cook in a preceding paper of this series. Among the 25 species represented several are very rare, being known only from the Galápagos Islands. These specimens are a valuable addition to the National Herbarium.

NAJADACEAE

*Najas marina* L. Sp. Pl. 1015. 1753.

Clipperton Island; lagoon back of landing place (no. 102). This collection represents form "A" in Rendle's monograph of the family,<sup>1</sup> the leaves being much broader than in the form common in the United States. This species is widely distributed throughout the world.

GRAMINEAE

*Aristida subspicata* Trin. & Rupr. Mém. Acad. Petersb. VI. 7: 125. 1849.

Elizabeth Bay, Albemarle Island (no. 107). Endemic to the Archipelago.

*Cenchrus echinatus* L. Sp. Pl. 1050. 1753.

Clipperton Island (no. 104). A common tropical weed.

AMARANTHACEAE

*Alternanthera echinocephala* (Hook. f.) Christophersen, Nyt. Mag. Naturvidensk. 70: 73. 1932.

*Brandesia echinocephala* Hook. f. Trans. Linn. Soc. 20: 189. 1847.

Charles Island (no. 119). Endemic to the Archipelago.

*Alternanthera nudicaulis* (Hook. f.) Christophersen, Nyt. Mag. Naturvidensk. 70: 73. 1932.

*Bucholtzia nudicaulis* Hook. f. Trans. Linn. Soc. 20: 191. 1847.

Charles Island (no. 126). Endemic to the Archipelago. Identified by John Thomas Howell, California Academy of Sciences.

<sup>1</sup> Pflanzenreich 4<sup>12</sup>. 1901.

## NYCTAGINACEAE

*Boerhaavia tuberosa* Lam. Ill. Gen. 1: 10. 1791.

Charles Island (no. 120). This species is common in the Galápagos Islands and occurs also in Peru. Records for *B. scandens* L. in the Archipelago evidently apply to *B. tuberosa*.<sup>2</sup>

## AIZOACEAE

*Sesuvium edmonstonei* Hook. f. Trans. Linn. Soc. 20: 221. 1847.

Sullivan Bay, James Island (no. 106). Endemic to the Islands.

## CAESALPINIACEAE

*Emelista tora* (L.) Britton & Rose, ex Britton & Wilson, Sci. Surv. Porto Rico & Virgin Is. 5: 371. 1924.

*Cassia tora* L. Sp. Pl. 376. 1753.

Charles Island (no. 125). Common throughout the Tropics and in warmer parts of temperate regions; apparently not before reported from the Galápagos Islands.

*Parkinsonia aculeata* L. Sp. Pl. 375. 1753.

Charles Island (no. 114). A common tree of the American Tropics.

## PAPILIONACEAE

*Parosela parvifolia* (Hook. f.) Macbr. Contr. Gray Herb. 65: 23. 1922.

*Dalea parvifolia* Hook. f. Trans. Linn. Soc. 20: 225. 1847.

Charles Island (no. 112). Species not previously represented in the National Herbarium.

The writer has given<sup>3</sup> reasons for retaining for this genus the name *Parosela*, in general use among American botanists. *Dalea* has been proposed as a conserved name by the International Committee on Nomenclature.

*Galactia velutina* Benth. in Tayl. Ann. Nat. Hist. 3: 437. 1839.

*Galactia jussiacana* var. *volubilis* Benth. in Mart. Fl. Bras. 15<sup>1</sup>: 143. 1859.

Elizabeth Bay, Albemarle Island (no. 109). Also in northern and eastern South America. In reports on the Galápagan flora this plant is listed as *G. jussiacana* var. *volubilis*, but special studies which the writer has made of South American Papilionaceae indicate that it represents a species distinct from *G. jussiacana*.

<sup>2</sup> See Standley, The Nyctaginaceae and Chenopodiaceae of northwestern South America, Field Mus. Bot. 11: 106. 1931.

<sup>3</sup> Journ. Washington Acad. Sci. 26: 360. 1936.

## EUPHORBIACEAE

*Phyllanthus niruri* L. Sp. Pl. 981. 1753.

Clipperton Island (no. 101). A common tropical weed.

## MALVACEAE

*Abutilon umbellatum* (L.) Sweet, Hort. Brit. 53. 1826.

*Sida umbellata* L. Syst. Nat. ed. 10, 1145. 1759.

Charles Island (no. 113). This genus is in need of thorough revision, and for the present I am accepting Svenson's views<sup>4</sup> in reducing the two supposedly endemic Galápagan species, *A. depauperatum* (Hook. f.) Anderss. and *A. anderssonianum* Garcke to synonyms of *A. umbellatum*, a rather widespread plant in tropical America.

*Anoda cristata* (L.) Schlecht. Linnaea 11: 210. 1837.

*Sida cristata* L. Sp. Pl. 684. 1753.

Charles Island (no. 122). Widely distributed in the Tropics.

*Gossypium barbadense* L. Sp. Pl. 603. 1753.

Charles Island (no. 115). In spite of the economic importance of this genus, its taxonomy is in a state of great confusion. The species name is here used in a broad sense.

## STERCULIACEAE

*Waltheria reticulata* Hook. f. Trans. Linn. Soc. 20: 231. 1847.

Charles Island (no. 123). Endemic to the Galápagos Islands.

## PASSIFLORACEAE

*Passiflora foetida* var. *galapagensis* Killip, Field Mus. Bot. 19: 505. 1938.

Charles Island (no. 110). Endemic to the Galápagos Islands.

## CONVOLVULACEAE

*Evolvulus glaber* Spreng. Syst. 1: 862. 1825.

Charles Island (no. 118). Widely distributed in the West Indies and northern South America; rarer elsewhere.

## BORAGINACEAE

*Cordia lutea* Lam. Ill. Gen. 1: 421. 1791.

Charles Island (nos. 111, 116). A showy plant, with large yellow flowers. Also in western South America.

<sup>4</sup>Amer. Journ. Bot. 22: 243. 1935.

*Heliotropium curassavicum* L. Sp. Pl. 130. 1753.

Clipperton Island (no. 103). Common on shores throughout the Tropics.

*Tournefortia pubescens* Hook. f. Trans. Linn. Soc. 20: 198. 1847.

Charles Island (no. 121). Endemic to the Galápagos. Identified by I. M. Johnston, of the Arnold Arboretum of Harvard University.

#### VERBENACEAE

*Lantana peduncularis* Anderss. Vet. Akad. Handl. Stockh. 1853: 200. 1854.

Charles Island (no. 124). Probably endemic to the Archipelago. Identified by H. N. Moldenke, of the New York Botanical Garden.

#### SOLANACEAE

*Cacabus miersii* (Hook. f.) Wettst. in Engl. and Prantl, Nat. Pflanzenfam. IV<sup>3b</sup>: 16. 1891.

*Diptycolyx miersii* Hook. f. Trans. Linn. Soc. 20: 203. 1847.

*Thinogeton miersii* Miers, Ann. Mag. Nat. Hist. II. 4: 359. 1849.

Elizabeth Bay, Albemarle Island (no. 108). Endemic. First fruiting specimens to be received at the National Herbarium.

*Physalis angulata* L. Sp. Pl. 183. 1753.

Charles Island (no. 117). Widely distributed in tropical America.

*Solanum nigrum* L. Sp. Pl. 186. 1753.

Clipperton Island (no. 105). A widely distributed, highly variable species.

SMITHSONIAN MISCELLANEOUS COLLECTIONS  
VOLUME 98, NUMBER 9

ALGAE COLLECTED ON THE PRESIDENTIAL  
CRUISE OF 1938

(WITH TWO PLATES)

BY  
WM. RANDOLPH TAYLOR  
University of Michigan, Ann Arbor



(PUBLICATION 3534)

CITY OF WASHINGTON  
PUBLISHED BY THE SMITHSONIAN INSTITUTION  
JUNE 23, 1939

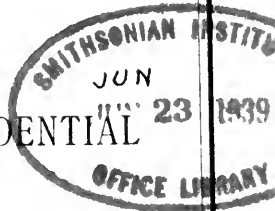



SMITHSONIAN MISCELLANEOUS COLLECTIONS  
VOLUME 98, NUMBER 9

ALGAE COLLECTED ON THE PRESIDENTIAL  
CRUISE OF 1938

(WITH TWO PLATES)

BY  
WM. RANDOLPH TAYLOR  
University of Michigan, Ann Arbor



(PUBLICATION 3534)

CITY OF WASHINGTON  
PUBLISHED BY THE SMITHSONIAN INSTITUTION  
JUNE 23, 1939

The Lord Baltimore Press  
BALTIMORE. MD., U. S. A.



# ALGAE COLLECTED ON THE PRESIDENTIAL CRUISE OF 1938

BY WM. RANDOLPH TAYLOR  
*University of Michigan, Ann Arbor*

(WITH TWO PLATES)

The algae collected on the 1938 Presidential Cruise of the Honorable Franklin D. Roosevelt by Waldo L. Schmitt, Curator of Invertebrates at the United States National Museum, consist of eight lots from five places visited. Ordinarily, so few samples would have yielded little, but it so happened that three of the eight were productive of novelties, and two, coming from places without previous algal record and quite unlikely soon again to yield collections, were of considerable special interest. By reason of lack of previous visits by phycologists nearly all of the records are new for their stations. For the opportunity of studying these algae the writer is indebted to the collector and the authorities of the National Museum. Type material of the new species has been deposited in the United States National Herbarium.

Of the collections from Magdalena Bay little need be said. They supplement each other and were dominated by *Chaetomorpha* and *Griffithsia*. The former genus is represented by *C. crassa*, a species more familiar from the West Indies, and one of a number of tropical Atlantic species turning up in collections from Pacific Central America and neighboring warm waters. The *Griffithsia* is even more interesting. On the west coast, species of this genus have given systematists trouble because they are persistingly sterile. On the east coast they are few in number but better known. On the European west coast they are more numerous. Here we have a species which is sufficiently characterized by its sporophytic phase to add a recognizable report to the American flora of a section of the genus as yet not reported there. It is very much simpler than any of the east-coast species and appears to be undescribed.

The Clipperton Island collections are unique, for landing on this isolated atoll is specially difficult. The jars of mixed algae from the lagoon were very surprising to the author. He had incorrectly assumed

that the water was salt, by seepage or other admixture from the sea. The plants found indicate on the contrary that it is at least nearly fresh, at any rate near the surface and in shallows, though probably heavily polluted with nitrogenous matter from the bird colonies. The bulk of the material was of Myxophyceae, which is appropriate under such conditions, and apparently great masses of *Lyngbya versicolor* must have been present at least near the shore. This is not a definitely marine species. With it were other Myxophyceae of cosmopolitan habits. In sparing amounts an undeterminable *Chara* appeared. Finally, four desmids were found in considerable numbers, one in particular (*Cosmarium clippertonensis*) which the writer inclines to treat as new. It should be observed that these species of desmids (which are as a group intolerant of salt) showed rather weak surface markings and considerable irregularity, so that perhaps they were adapted to slightly brackish conditions. This is supported by the presence of the only phanerogam associate, *Najas marina*, which is normally an inhabitant of brackish water. No hydrometer readings were made, unfortunately.

The algae of Old Providence Island, Colombia, off the Nicaraguan coast, were collectively quite in accord with what would have been expected in any productive locality in the Gulf of Mexico and adjacent waters. One minute encrusting *Fosliella* was particularly attractive and exhibited a type of variation not known in *F. farinosa* or the group to which it belongs, so it is described as new. These add a few welcome records to an unexplored section of the Atlantic Central American coast. Apparently material from various spots were mingled, so it is impossible to indicate exactly the habitat in the appended list.

#### SYSTEMATIC LIST

#### MYXOPHYCEAE

#### CHROOCOCCACEAE

##### *Chroococcus turgidus* (Kützing) Nägeli

Occasional among filamentous algae in the lagoon, Clipperton Island, Mexico (*Schmitt* 21), July 21, 1938.<sup>1</sup>

##### *Microcystis flos-aquae* (Wittrock) Kirchner

Colonies infrequent among filamentous algae in the lagoon, Clipperton Island, Mexico (*Schmitt* 21), July 21, 1938.

<sup>1</sup> The collection numbers were assigned by the author after the material had been sorted and mounted.

**Gomphosphaeria aponina** Kützing

Infrequent colonies among filamentous algae in the lagoon, Clipperton Island, Mexico (*Schmitt 21*), July 21, 1938.

## CHAMAESIPHONACEAE

**Xenococcus pyriformis** Setchell & Gardner

With other, indeterminable, Myxophycean epiphytes on *Bostrychia binderi*, probably from mangrove roots, south end of black beach, Elizabeth Bay, Isabela Island, Archipelago de Colon, Ecuador (Albemarle Island, Galápagos Islands) (*Schmitt 27*), July 28, 1938.

## OSCILLATORIACEAE

**Lyngbya aestuarii** (Mertens) Liebmann

Scattered trichomes in and among the masses of *L. versicolor*, lagoon back from the landing place, Clipperton Island, Mexico (*Schmitt 21*), July 21, 1938. Determined by the kindness of Dr. Francis Drouet.

**Lyngbya lagerheimii** (Möbius) Grunow

Scattered trichomes among the masses of *L. versicolor*, particularly evident in sediment of liquid from which the *L. versicolor* had been strained, from the lagoon back from the landing place, Clipperton Island, Mexico (*Schmitt 21*), July 21, 1938. Determined by F. Drouet.

**Lyngbya versicolor** (Wartmann) Gomont

Forming large masses, and probably extremely abundant, associated with smaller amounts of other species of algae and phanerogams, particularly *Najas marina*, in the lagoon back from the landing place, Clipperton Island, Mexico (*Schmitt 21*), July 21, 1938. Determined by F. Drouet.

## RIVULARIACEAE

**Calothrix stellaris** Bornet & Flahault

On leaves of *Najas marina* from the lagoon back from the landing place, Clipperton Island, Mexico (*Schmitt 21*), July 21, 1938. Determined by F. Drouet.

## CHLOROPHYCEAE

## DESMIDIACEAE

*Closterium parvulum* Nägeli, forma.

Text fig. 8.

These plants are consistently larger (length  $150\ \mu$ , width  $22\ \mu$ ) than the species as described by West and West (1905, p. 133) and they curve through a greater arc. Krieger (1935, p. 277, *pl. 16, fig. 18*) in var. *majus* West admits larger forms and in var. *angustum* West and West forms as curved; the present type probably represents yet another minor variant of the species. Rich's African *C. prolongum* figured on the same plate has more pyrenoids, is somewhat larger and has a greater median swelling, but is otherwise similar.

Infrequent in the lagoon, particularly in strainings from the *Lyngbya* masses, Clipperton Island, Mexico (*Schmitt 21*), July 21, 1938.

*Closterium parvulum*, near var. *majus* West.

Text fig. 9.

These plants were a little more tapering and curved than figured by Krieger (1935, p. 277, *pl. 16, fig. 18*), but apparently were within his concept of the species and perhaps of the variety. Length  $170\ \mu$ , width  $21.5\ \mu$ .

Frequent in the lagoon, particularly in strainings from the *Lyngbya* masses, Clipperton Island, Mexico (*Schmitt 21*), July 21, 1938.

*Cosmarium clippertonensis*, n. sp.<sup>2</sup>

Text figs. 1-7.

Cells small, semicells subtriangular, much wider than long, the end narrowly transversely truncate or slightly retuse, the basal angles obliquely truncate, the sinus closed; in polar view oval with a prominent lateral thickened swelling; in edge view the semicells subcircular with the same swelling visible; pyrenoids single in each semicell. the wall smooth. Length  $22-24\ \mu$ , width  $19-20\ \mu$ , thickness  $13.2\ \mu$ , isthmus  $4.5\ \mu$ .

These plants seem closest to *C. wembacrense* forma of Borge (1933, p. 14, *pl. 1, fig. 11*). They are not so like his *C. scopulorum* (1923, p. 12, *pl. 1, fig. 1*), to which he refers, and even less like the

<sup>2</sup> *Cosmarium clippertonensis*, spec. nov.—Cellulae parvae, semicellulis subtriangulis, latioribus quam longioribus, transverse truncatis vel retusiusculis; angulis basalibus obliquiter truncatis; sinu inaperto; aspectu polari ovalibus, lateraliter incrassatis bullatisque; aspectu laterali semicellulis subglobosis etiamque cum incrassationibus visibilibus; pyrenoideis in semicellula singulis; membrana laevi.

original *C. zembacense* Schmidle (1898, p. 33, *pl. 2, fig. 8*), although of about the same size. The lateral semicell faces are not as distinctively elevated and thickened in these plants as they are in those from the Clipperton lagoon. There are a number of other forms recorded with approximately the same size and practically the same contour from face view (or with but slightly more broadly truncate apices),

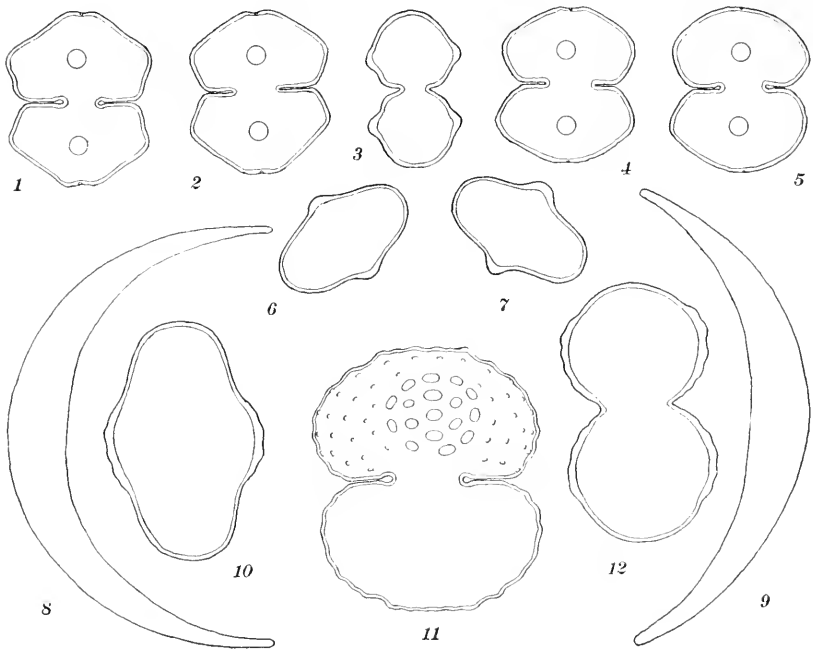

FIGS. 1-12.

1-7, *Cosmarium clippertonensis*, face (1, 2, 4, 5), edge (3) and polar views (6, 7), all  $\times 940$ . 8, *Closterium parvulum* forma,  $\times 375$ . 9, *Closterium parvulum* near v. *majus*,  $\times 375$ . 10-12, *Cosmarium subprotumidum*, polar (1), face (11), and edge (12) views,  $\times 940$ .

but usually the lateral faces are not markedly elevated, or evidence on this point, from a good polar view, is quite lacking.

Very common in the lagoon, particularly in the strainings from the *Lyngbya* masses, Clipperton Island, Mexico (*Schmitt 21*), July 21, 1938.

*Cosmarium subprotumidum* Nordstedt, forma.

Text figs. 10-12.

These plants were generally a little large for the species, with the lateral granules very small and obscure, those on the central protuberance large but low and not very refractive.

Common in the lagoon, particularly in the strainings from the *Lyngbya* masses, Clipperton Island, Mexico (*Schmitt 21*), July 21, 1938.

#### OÖCYSTACEAE

*Oöcystis solitaria* Wittrock, approaching forma major Wille

Generally solitary, occasionally 2-8 individuals in a common membrane, the cells to 24  $\mu$  wide, 36  $\mu$  long, broadly round-oval; wall firm, with well-defined knobs at each pole, both of the individual cells and the colonial envelope when it is present.

Frequent among filamentous algae in the lagoon, Clipperton Island, Mexico (*Schmitt 21*), July 21, 1938.

#### ULVACEAE

*Ulva* sp.

Juvenile, only about 15 mm. tall, thickness above to 45  $\mu$ , cells in section a little deeper than broad. Apparently abundant.

From rocks, shallow water along the shore of Fernandina Island, Archipelago de Colon, Ecuador (Narborough Island, Galápagos Islands) (*Schmitt 23*), July 25, 1938.

#### OEDOGONIACEAE

*Oedogonium* sp.

Sterile and not determinable. Filaments about 8.5  $\mu$  diameter.

Filaments frequent, among other algae in the lagoon, Clipperton Island, Mexico (*Schmitt 21*), July 21, 1938.

#### VALONIACEAE

*Halicystis ovalis* (Lyngbye) Areschoug

With *Amphiroa annulata*, from rocks, shallow water along the shore of Fernandina Island, Archipelago de Colon, Ecuador (Narborough Island, Galápagos Islands) (*Schmitt 24*), July 25, 1938.

*Valonia ventricosa* J. Agardh

In shallow water, probably from reefs, and bearing numerous epiphytes, Old Providence Island, Colombia (*Schmitt 32*), August 6, 1938.

## CLADOPHORACEAE

**Chaetomorpha crassa** (C. Agardh) Kützing

Unattached, the filaments long, moderately flexuous but not conspicuously entangled, adhering well to paper; cells 480-640  $\mu$  diameter, 1-2 diameters long, the nodes little constricted, the walls moderately thick.

Dredged in quantity at 20-30 m. over a sandy, weedy bottom in Magdalena Bay, Baja California, Mexico (*Schmitt* 6), July 18, 1938.

## CAULERPACEAE

**Caulerpa racemosa** (Forsskål) J. Agardh, forma

Apparently a reduced form. The erect branches were 1-3 cm. tall. The branchlets were cylindrical, with the tips slightly tapered, about 1.5 mm. diameter, 3-10 mm. apart on the axis, often opposite, with slight tendency to a bilateral arrangement. Without more ample material it seems unwise to describe even a new form in this difficult genus.

On rocks in shallow water to the south of the landing place, Clipperton Island, Mexico (*Schmitt* 14), July 21, 1938.

**Caulerpa sertularioides** var. **brevipes** (J. Agardh) Svedelius

In shallow water, Old Providence Island, Colombia (*Schmitt* 38), August 6, 1938.

## CODIACEAE

**Codium decorticatum** (Woodward) Howe

Branching irregular, the branches to 5 mm. diameter when dried, the utricles unarmed, to 360-480  $\mu$  diameter.

One piece dredged at 20-30 m. between Belcher Point and the anchorage, Magdalena Bay, Baja California, Mexico (*Schmitt* 1), July 18, 1938.

**Halimeda opuntia** (Linnaeus) Lamouroux

On a bottom of coral sand, shallow water, Old Providence Island, Colombia (*Schmitt* 37), August 6, 1938.

**Halimeda simulans** Howe

In shallow water, Old Providence Island, Colombia (*Schmitt* 37), August 6, 1938.

**Penicillus capitatus** Lamareck

Old Providence Island, Colombia; bottom sample at anchorage (*Schmitt* 30), in coral sand in shallow water (*Schmitt* 36); August 6, 1938.

**Penicillus dumetosus** (Lamouroux) Blainville

In coral sand, shallow water, Old Providence Island, Colombia (*Schmitt* 35), August 6, 1938.

**Rhizocephalus phoenix** (Ellis & Solander) Kützing, near f. **typicus** Gepp.

On coral sandy bottom in shallow water, Old Providence Island, Colombia (*Schmitt* 33), August 6, 1938.

**Udotea conglutinata** (Solander) Lamouroux

On shells in coral sandy bottom in shallow water, Old Providence Island, Colombia (*Schmitt* 34), August 6, 1938.

## CHAROPHYCEAE

## CHARACEAE

**Chara** sp.

Sterile, and so quite undeterminable. However, the leaves had naked basal internodes more than twice as long as broad, much exceeding the bracteoles, so it is probable that the plants belong to the same group as *C. elegans*.

Scanty, with *Lyngbya versicolor*, from the lagoon back from the landing place, Clipperton Island, Mexico (*Schmitt* 21), July 21, 1938.

## PHAEOPHYCEAE

## DICTYOTACEAE

**Dictyopteris delicatula** Lamouroux

On the basal parts of *Zonaria variegata*, rocks south of the landing place, Clipperton Island, Mexico (*Schmitt* 15), July 21, 1938; probably from reef pools, Old Providence Island, Colombia, with *Falonia ventricosa* (*Schmitt* 32) and with *Amphiroa fragilissima* (*Schmitt* 49), August 6, 1938.

**Dictyota crenulata** J. Agardh

Dredged sparingly with *Griffithsia* in 12-20 m. on a sandy bottom off Punta Gorda and nearby, Cap San Lucas, Baja California, Mexico (*Schmitt* 7), July 19, 1938.



**Dictyota divaricata** Lamouroux

In shallow water, probably on reefs, Old Providence Island, Colombia (*Schmitt* 41), and with *Laurencia obtusa* (*Schmitt* 51), August 6, 1938.

**Padina durvillaei** Bory

Sparingly dredged with *Griffithsia* in 12-20 m. over a sandy bottom off Punta Gorda and nearby, Cap San Lucas, Baja California, Mexico (*Schmitt* 8), July 19, 1938.

**Zonaria variegata** (Lamouroux) Mertens

With sori. Apparently abundant, from rocks in shallow water south of the landing place, Clipperton Island, Mexico (*Schmitt* 16), July 21, 1938; in shallow water, probably on reefs, Old Providence Island, Colombia (*Schmitt* 40), August 6, 1938.

## ASPEROCOCCACEAE

**Colpomenia sinuosa** (Roth) Derbès & Solier

From rocks, shallow water along the shore of Fernandina Island, Archipelago de Colon, Ecuador (Narborough Island, Galápagos Islands) (*Schmitt* 25), July 25, 1938.

## FUCACEAE

**Sargassum polyceratium** Montagne

In shallow water, probably on reefs, Old Providence Island, Colombia (*Schmitt* 42), August 6, 1938.

## RHODOPHYCEAE

## CHAETANGIACEAE

**Galaxaura lapidescens** (Ellis & Solander) Lamouroux

In shallow water, probably on reefs, Old Providence Island, Colombia (*Schmitt* 47), August 6, 1938.

**Galaxaura squalida** Kjellman

In shallow water, probably on reefs, Old Providence Island, Colombia (*Schmitt* 48), August 6, 1938.

## GELIDIACEAE

*Gelidium pusillum* var. *conchicola* Piccone & Grunow

From bottom sample at anchorage, Old Providence Island, Colombia (*Schmitt* 31), August 6, 1938.

## CORALLINACEAE

## MELOBESIEAE

*Fosliella farinosa* (Lamouroux) Howe

In shallow water, Old Providence Island, Colombia, epiphytic on *Cymodocea manatorum* (*Schmitt* 44 p. p.), probably on reefs; epiphytic on *Valonia ventricosa* (*Schmitt* 32); and on *Laurencia obtusa* (*Schmitt* 51), August 6, 1938.

*Fosliella farinosa* (Lamouroux) Howe, n. var. *chalicodictya*<sup>3</sup>

Text figs. 13, 14, plate 1, figs. 1-3.

Plants small, forming minute coalescent lightly calcified crusts which individually may reach 1, rarely 2 mm. in diameter; crusts filamentous, the filaments sinuous to angularly bent, laterally cohering at the points of contact, or anastomosing, to form a definite network, the cells generally 10-12  $\mu$  diameter, 15-20  $\mu$  long, with small superficial cortical cells superposed at the ends; occasional hyaline hair-bearing cells 18-22  $\mu$  diameter also present.

In shallow water, Old Providence Island, Colombia; probably on reefs as epiphytic on *Valonia ventricosa* (*Schmitt* 32), August 6, 1938.

This plant was mixed with *F. farinosa* var. *solmsiana* and other, unidentifiable Melobesieae, but usually monopolized the cell upon which it grew. The variety *solmsiana* characteristically forms small fanlike patches a few to several filaments wide (*pl. I, fig. 1c*), the patches linked by some filaments which far outstrip the rest and spread out to form new fans at their ends. The plant here specially described forms close crusts which often coalesce (*pl. I, fig. 1*). It is quite impossible to separate from the host for mounting those with the largest meshes, but these meshes are frequently quite regular and 40-60  $\mu$  or more in diameter. Those crusts which have smaller

<sup>3</sup> *Fosliella farinosa*, var. nov. *chalicodictya*—Plantae pusillae, 1-2 mm. diam., inter se coalescentes, modice calce incrustatae, filamentosae; filamentis flexuosis reticulum fere regulare formantibus; cellulis 10-12  $\mu$  diam., 15-20  $\mu$  longis, ad apices praeditis cum superficialibus cellulis superpositis; piliferis cellulis hyalinis 18-22  $\mu$  diam.

meshes are more easily detached in relatively large pieces, and show the dichotomous filamentous structure better (*pl. 1, figs. 2, 3*). The latter type appears in text figure 13, and a transition zone between small and larger meshes in figure 14. Occasionally in crowded areas a three-dimensional sponge is formed, but this is restricted. As originally described, *M. solmsiana* Falkenberg (1901, p. 109) was intended

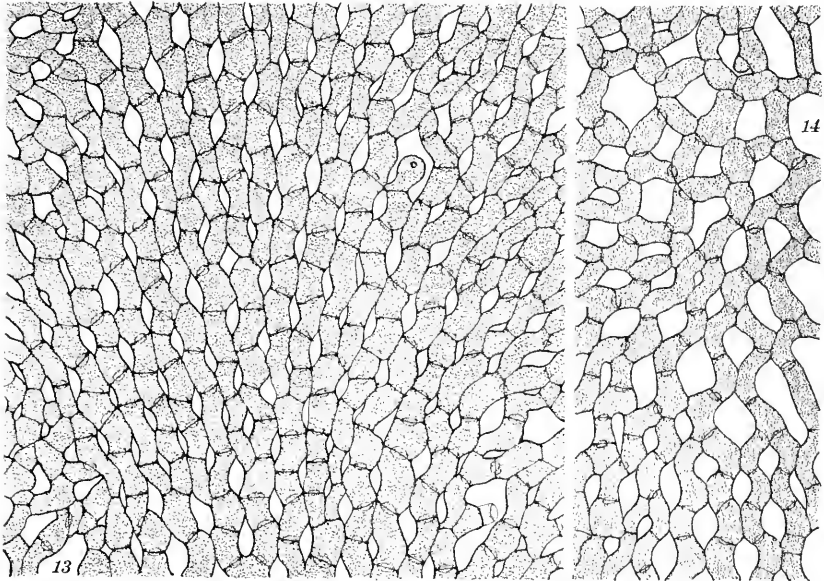

FIGS. 13, 14.—*Fosiella farinosa* var. *chalicodictya*, views of portions of two nets,  $\times 300$ .

The net shown in fig. 13 is one with a rather small mesh. The small corticating cells show at the ends of the cells making up the constituent filaments, and one young hair-bearing cell appears in the upper right-hand quarter of the drawing. The net shown in fig. 14 illustrates the transition between a coarser mesh above and a smaller one below.

to apply to a plant with irregular, lacunose growth of the filaments, so that a continuous plate was not formed; there is nothing about the figures of Solms-Laubach (1881, p. 11, *pl. 1, fig. 13*) to indicate that he had met a plant forming a regular net of the type observed in this material from Old Providence Island.

***Fosiella farinosa* var. *solmsiana*** (Falkenberg), n. comb.

On *Valonia ventricosa*, from shallow water, probably on reefs, Old Providence Island, Colombia (*Schmitt 32*), August 6, 1938.

The nomenclatorial status of this plant seems somewhat confused. Falkenberg in using the name *callithamnioides* for it thought his plant was the same as that of the Crouans; he therefore simply made a new combination in attaching the specific name to *Melobesia* and did not describe his plant. When he admitted the error in identification, he named his plant *M. solmsiana*; he did not describe it even then, but did refer to Solms-Laubach's excellent account. It would seem that the name *Solmsiana* alone signifies, though perhaps its title is not quite regular. Whether one considers it a form or a variety is a matter of opinion, and the writer is not sure that the name may not have been used as that of a variety before Lemoine did so. Since she used the name in the genus *Melobesia*, it is unfortunately necessary to make a new combination in the genus *Fosliella*. The more important records consulted follow: *Melobesia callithamnioides* Falkenberg 1879, p. 265, regarding the plant. Neither *Hapalidium callithamnioides* Crouan 1859, p. 287, *pl. 21, figs. 21-21*, nor 1867, p. 149, *pl. 20, figs. 1-3*. Not *Melobesia callithamnioides* (Crouan) Falkenberg *loc. cit.*, regarding the name. Not *Guerinea callithamnioides* (Crouan) Picquenard, *cf. DeToni* 1924, p. 530. *M. callithamnioides* Falkenberg, Solms-Laubach 1881, p. 11, *pl. 1, fig. 13*, and Hauck 1885, p. 262, *fig. 106* (after Solms-Laubach). *M. solmsiana* Falkenberg 1901, p. 109 (no illustrations, no description). *M. farinosa* forma *solmsiana* (Falkenberg) Foslie 1908, p. 16. *M. callithamnioides* Falkenberg, Migula 1909, p. 155, *pl. 53M, fig. 6*, and Schiffner 1916, p. 151. *M. farinosa* var. *solmsiana* Lemoine in Børgesen 1917, p. 173, *fig. 165 d, e*, and Taylor 1928, p. 211. *M. farinosa* var. *callithamnioides* Foslie, Newton 1931, p. 301.

#### **Lithophyllum alternans** Lemoine

Collected along the shore, Fernandina Island, Archipelago de Colon, Ecuador (Narborough Island, Galápagos Islands) (*Schmitt* 26), July 25, 1938.

#### **Lithophyllum pustulatum** (Lamouroux) Foslie

On *Laurencia obtusa* in shallow water, probably on reefs, Old Providence Island, Colombia (*Schmitt* 51), August 6, 1938.

#### **Lithothamnion mesomorphum** Foslie

Probably on the reef, Old Providence Island, Colombia (*Schmitt* 52), August 6, 1938.

**Melobesia membranacea** (Esper) Lamouroux

In shallow water, Old Providence Island, Colombia; on sandy bottom epiphytic on *Thalassia testudinum* (Schmitt 43), epiphytic on *Cymodocea manatorum* (Schmitt 44 *f. f.*).

## CORALLINEAE

**Amphiroa annulata** Lemoine

From rocks, shallow water along the shore of Fernandina Island, Archipelago de Colon, Ecuador (Narborough Island, Galápagos Islands) (Schmitt 24), July 25, 1938.

**Amphiroa fragilissima** (Linnaeus) Lamouroux

Probably from reef pools, Old Providence Island, Colombia (Schmitt 49), August 6, 1938.

**Jania capillacea** Harvey

In shallow water, on *Zonaria*, rocks south of the landing place, Clipperton Island, Mexico (Schmitt 17), July 21, 1938; in shallow water, probably on reefs, Old Providence Island, Colombia, on *Acanthophora spicifera* (Schmitt 45) and with *Laurencia obtusa* (Schmitt 51), August 6, 1938.

## GRATELOUPIACEAE

**Prionitis lyallii** Harvey

Dredged at 20-30 m. between Belcher Point and the anchorage, Magdalena Bay, Baja California, Mexico (Schmitt 2), July 18, 1928.

## RHABDONIACEAE

**Catenella opuntia** Greville

With *Bostrychia binderi*, probably from mangrove roots, south end of black beach, Elizabeth Bay, Isabela Island, Archipelago de Colon, Ecuador (Albemarle Island, Galápagos Islands) (Schmitt 27), July 28, 1938.

## GRACILARIACEAE

**Gracilaria confervoides** (Linnaeus) Greville

Fragments, apparently of this species, dredged in 20-30 m. between Belcher Point and the anchorage, Magdalena Bay, Baja California, Mexico (Schmitt 4), July 18, 1938.

*Gracilaria pinnata* Setchell & Gardner

Small pieces dredged at 20-30 m. between Belcher Point and the anchorage, Magdalena Bay, Baja California, Mexico (*Schmitt* 3), July 18, 1938.

## CERAMIACEAE

*Centroceras clavulatum* (C. Agardh) Montagne

Probably from reef pools, Old Providence Island, Colombia, with *Valonia ventricosa* (*Schmitt* 32), with *Amphiroa fragilissima* (*Schmitt* 49), August 6, 1938.

*Ceramium byssoideum* Harvey

In shallow water, probably on reefs, Old Providence Island, Colombia, on *Acanthophora spicifera* (*Schmitt* 46), on *Laurencia obtusa* (*Schmitt* 51), August 6, 1938.

*Ceramium fastigiatum* Harvey, forma

Small tufts scattered among masses of *Griffithsia*, 1-2 cm. tall. The older filaments usually reached a diameter of about 85  $\mu$ , with internodes about 240  $\mu$  long, and only exceptionally did the diameter reach 180  $\mu$ , when the internodes were but 150  $\mu$  long and the nodes only 30  $\mu$  deep; nodes of only 1-2 rows of cells, even in the largest.

These plants in diameter of the filaments and character of the forcipate apices are intermediate between the northern Atlantic *C. fastigiatum* and the tropical forma *flaccidum* Petersen, the nodes particularly resembling the latter.

Dredged sparingly at 12-20 m. with *Griffithsia* over sandy bottom off Punta Gorda and nearby, Cap San Lucas, Baja California, Mexico (*Schmitt* 12), July 19, 1938.

*Griffithsia multiramosa* (Setchell & Gardner), n. comb., n. var. *minor*<sup>4</sup>

Plants forming gregarious tufts about 2-4 cm. tall, extremely soft, almost lubricous in texture, bright rose pink when dried; filaments

<sup>4</sup> *Griffithsia multiramosa* n. var. *minor*.—Plantae gregariae, ramosae, grandiores 2-4 cm. altae, flaccidae, filamentis plerumque pseudodichotomis, dichotomiis deorsum obtuse sursum acute angulatis; cellulis cylindricis, eis infra dichotomias positiss subclavatis, eis ramorum inferiorum ad nodos paululum distentis; filamentis plantae basin interdum 300  $\mu$  diam., cellulis inferioribus longitudine usque ad 1260  $\mu$ , in media plantae parte crassitudine usque ad 125  $\mu$ , longitudine usque ad 970  $\mu$ , in ramulis ultimis crassitudine 15-20  $\mu$ , longitudine 100-200  $\mu$ ; ramulis sursum angustatis, apice rotundatis; tetrasporangiis lateralibus, solitariis, in pedicellis unicellulis sedentibus, absque involucris; pilis pellucidis nullis. Plantae sexuales ignotae.

branching pseudodichotomously, or occasionally slightly irregularly in upper portions; lower parts of the plant of coarse filaments which measure to  $300\ \mu$  diameter at the slightly swollen nodes, the thick-walled cells to  $1260\ \mu$  long, and which branch at wide angles; middle and upper portions of the plant of very erect more slender filaments branching at very acute angles, the cells when supporting a fork somewhat clavate, otherwise subcylindrical, about  $125\ \mu$  diameter, the cells to  $970\ \mu$  long; ultimate branching more often alternate than anywhere else in the plant, the branchlets to  $15\text{--}20\ \mu$  diameter, their cells to  $100\text{--}200\ \mu$  long, those at the apices of the filaments tapered, rounded-acute; colorless hairs absent; spherical tetrasporangia  $50\text{--}75\ \mu$  diameter, on one-celled stalks, solitary at the nodes of the upper middle parts of the plant, apparently very infrequent, without any trace of involucre cells; sexual organs not seen.

Dredged in abundance at 12-20 m. over sandy bottom, off Punta Gorda and nearby, Cap San Lucas, Baja California, Mexico (*Schmitt* 13), July 19, 1938.

This plant probably represents the species described by Setchell and Gardner (1937, p. 87) as *Neomonospora multiramosa* Setchell & Gardner. It is shorter, and the ultimate branchlets are more slender than they report; the tetrasporangia are a little larger in their greatest dimension reached, and in particular, they divide in tetrahedral (tripartite) fashion, not cruciately. The dimensional differences are of but secondary importance; the fashion of division of the sporangia is important and the writer has most carefully confirmed his observation on material conserved in formalin. He sees no need for placing these plants in the old algal genus *Monospora* (or a substitute for it), since the sporangia there are borne laterally on special branchlets of a well-defined type, not present here. The species appears to belong to a small section of the genus *Griffithsia* ill-known by reason of the infrequency of reproductive organs, but characterized among other features by the lack of any involucre cells about the tetrasporangia. It is smaller than *G. arachnoidea* C. Agardh (*G. furcellata* J. Ag.) (Børjesen 1930, p. 29; Funk 1922, p. 226, *pl.* 5, *fig.* 3) with shorter and probably more clavate cells. This is a species of the Mediterranean and the Canary Islands. It shows marked resemblance to the larger *G. comosa* Grunow (1867, p. 62, *pl.* 10, *fig.* 2) from New Zealand, which has the same swollen ends to the apparently longer cells, but tetrasporangia are not known for that species. In the lack of sufficient evidence to link these specimens with either of the earlier-described plants it seems best to treat them as new, since they can, with the aid of the tetrasporangia, be fairly clearly defined.

## RHODOMELACEAE

**Acanthophora spicifera** (Vahl) Børgesen

In shallow water, probably on reefs, with *Ceramium byssoidcum*, Old Providence Island, Columbia (*Schmitt* 46), August 6, 1938.

**Bostrychia binderi** Harvey

Probably from mangrove roots, south end of black beach, Elizabeth Bay, Isabela Island, Archipelago de Colon, Ecuador (Albemarle Island, Galápagos Islands) (*Schmitt* 27), July 28, 1938.

**Bryothamnion triquetrum** (Gmelin) Howe

In shallow water, probably on reefs, Old Providence Island, Colombia (*Schmitt* 50), August 6, 1938.

**Laurencia obtusa** (Hudson) Lamouroux

Bearing numerous epiphytes, in shallow water, probably on reefs, Old Providence Island, Colombia (*Schmitt* 51), August 6, 1938.

**Pterosiphonia dendroidea** (Montagne) Falkenberg

Dredged in 6-10 fathoms off Punta Gorda, off rocky shore to west, and San Jose del Cabo Bay, Cap San Lucas, Baja California, Mexico (*Schmitt* 10), July 19, 1938.

These pieces, though slender in axis and branchlets, otherwise compare very closely with the specimens from Peru collected by Coker and reported upon by Howe (1914, p. 144), which the writer has been able to examine through the kindness of the Curator, New York Botanical Garden.

## LITERATURE CITED

## BORGE, O.

1923. Beiträge zur Algenflora von Schweden 3. Arkiv f. Bot. 18(10): 1-34.

1933. Schwedisch-chinesische wissenschaftliche Expedition nach den nord-westlichen Provinzen Chinas. Arkiv f. Bot. 25 A (17): 1-18.

## BØRGESEN, F.

1915-20. Marine Algae of the Danish West Indies. Dansk Bot. Arkiv 1(4): 1-160; 2(2): 1-68; 3: 1-504.

1930. Marine Algae from the Canary Islands especially from Teneriffe and Gran Canaria. III. Rhodophyceae, 3 Ceramiales. Kongel. Danske Vidensk. Selsk., Biol. Medd. IX, 1: 1-159.



CROUAN, P. L. & H. M.

1859. Notice sur le Genre Hapalidium. *Ann. Sci. Nat.* IV, Bot. 12: 284-287.

1867. Florule du Finistere. . . . 10 + 262 pp., frontisp., 31 pl. + suppl. Brest.

DETONI, G. B.

1889-1924. *Sylloge algarum omnium hucusque cognitarum*. 1 (*Sylloge Chlorophycearum*): 1-12, I-CXXXIX, 1-1315. 1889. 3 (*Sylloge Fucoidearum*): I-XVI, 1-638. 1895. 4 (*Sylloge Floridearum*) (1): I-XX, I-LXI, 1-388. 1897; (2): 387-776. 1900; (3): 775-1525. 1903; (4): 1523-1973. 1905. 6 (*Sylloge Floridearum*) (5, *Additamenta*): I-XI, 1-767. 1924. Patavii.

FALKENBERG, P.

1879. Die Meeres-algen des Golfes von Neapel. *Mitt. Zool. Sta. Neapel* 1: 218-277.

1901. Die Rhodomelaceen des Golfes von Neapel und der angrenzenden Meeres-Abschnitte. *Fauna und Flora des Golfes von Neapel*. . . . 26: 16 + 754 pp., 24 pl. Naples.

FOSLIE, M.

1900. Remarks on Melobeseae in Herbarium Cronan. *Kongel. Norske Vidensk. Selsk. Skr.* 1899 (7): 1-15.

1908. Algologiske Notiser V. *Kongel. Norske Vidensk. Selsk. Skr.* 1908 (7): 1-20.

FUNK, G.

1922. Über einige Ceramiaceen aus dem Golf von Neapel. *Beih. Bot. Centrallbl.* 39 Abt. 2: 223-247.

GRUNOW, A.

1867. Algen, in Reise seiner Majestät Fregatte Novara um die Erde. *Botanisches Theil*, 1: 1-104.

HAUCK, F.

1885. Die Meeresalgen Deutschlands und Österreichs. In L. Rabenhorst, *Kryptogamen-Flora von Deutschland, Österreich und der Schweiz*, 2 Aufl., 2: 1-575.

HOWE, M. A.

1914. The marine algae of Peru. *Mem. Torr. Bot. Club* 15: 1-185.

KRIEGER, W.

1933-1937. Die Desmidiaceen Europas, mit Berücksichtigung der außereuropäischen Arten I. In L. Rabenhorst, *Kryptogamen-Flora von Deutschland, Österreich und der Schweiz*, 3 Aufl., 13: 1-712.

MIGULA, W.

1907-1909. Algen. In Thomé, *Flora von Deutschland, Österreich und der Schweiz*, VII, 2(1): 1-918, 2(2): 1-383.

SCHIFFNER, V.

1916. Studien über Algen des Adriatischen Meeres. *Wiss. Meeresuntersuch.* N.F., Abt. Helgoland, 11: 129-198.

SCHMIDLE, W.

1898. Die von Professor Dr. Volkens und Dr. Stuhlmann in Ost-Africa gesammelten Desmidiaceen. [Engler's] *Bot. Jahrb.* 26: 1-59.

SETCHELL, W. A., & GARDNER, N. L.

1937. The Templeton Crocker Expedition of the California Academy of Sciences, 1932. No. 31. A preliminary report on the Algae. Proc. California Acad. Sci. 22(2) : 65-98.

TAYLOR, W. R.

1928. Marine Algae of Florida, with special reference to the Dry Tortugas. Papers Tortugas Lab., Carnegie Inst. Washington 25: 1-219.

WEST, W., & WEST, G. S.

1905. A monograph of the British Desmidiaceae. 2: 10 + 206 pp. London.

## EXPLANATION OF PLATES

### PLATE I

*Fosliella farinosa* var. *chalicodictya*. FIG. 1, surface of dried *Falonia* with *Fosliella*,  $\times 25$ . Near "a" appears a group of good, large-meshed crusts of var. *chalicodictya*, and near "b" a group of crusts with very small meshes, hardly visible in the reproduction. Near "c" are some individuals of the var. *solmsiana*, of which other patches appear among the crusts of var. *chalicodictya*. FIG. 2, surface of a moderately small-meshed net,  $\times 110$ . FIG. 3, surface of rather larger meshed net,  $\times 70$ . Occasional strands of var. *solmsiana* overlie the nets.

### PLATE 2

*Griffithsia multiramosa* var. *minor*. FIG. 1, habit of upper branching of a tetrasporangium-bearing plant, the branches slightly spread from the normally erect position,  $\times 33$ . FIG. 2, lower branches of the same plant, the protoplasts as outlined considerably shrunken,  $\times 33$ . FIG. 3, tips of a few branchlets,  $\times 195$ . FIGS. 4-7, portions of branches with tetrasporangia,  $\times 130$  except fig. 5,  $\times 75$ .



FOSLIELLA FARINOSA VAR. CHALICODICTYA  
(For explanation, see p. 18.)

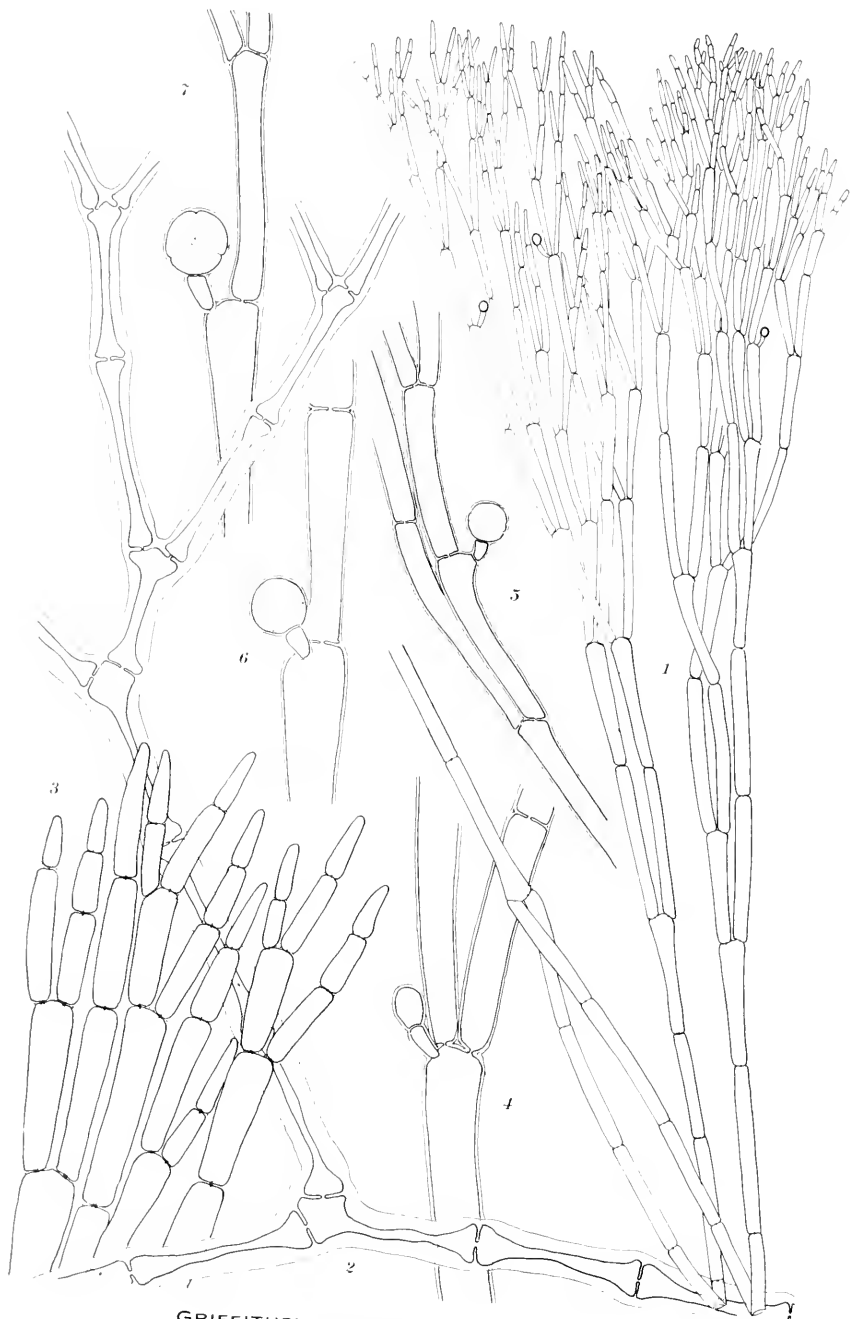

*GRIFFITHSIA MULTIRAMOSA* VAR. *MINOR*

(For explanation, see p. 18.)

SMITHSONIAN MISCELLANEOUS COLLECTIONS  
VOLUME 98, NUMBER 10

MOLLUSKS COLLECTED ON THE  
PRESIDENTIAL CRUISE OF  
1938

(WITH FIVE PLATES)

BY

PAUL BARTSCH

Curator, Division of Mollusks,  
U. S. National Museum

AND

HARALD ALFRED REHDER

Assistant Curator, Division of Mollusks,  
U. S. National Museum

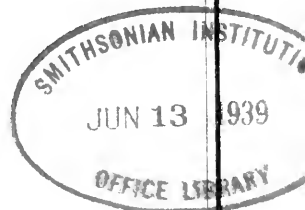

(PUBLICATION 3535)

CITY OF WASHINGTON  
PUBLISHED BY THE SMITHSONIAN INSTITUTION  
JUNE 13, 1939



SMITHSONIAN MISCELLANEOUS COLLECTIONS

VOLUME 98, NUMBER 10

MOLLUSKS COLLECTED ON THE  
PRESIDENTIAL CRUISE OF  
1938

(WITH FIVE PLATES)

BY

PAUL BARTSCH

Curator, Division of Mollusks,  
U. S. National Museum

AND

HARALD ALFRED REHDER

Assistant Curator, Division of Mollusks,  
U. S. National Museum



(PUBLICATION 3535)

CITY OF WASHINGTON  
PUBLISHED BY THE SMITHSONIAN INSTITUTION  
JUNE 13, 1939

The Lord Baltimore Press  
BALTIMORE, MD., U. S. A.



MOLLUSKS COLLECTED ON THE PRESIDENTIAL  
CRUISE OF 1938

BY PAUL BARTSCH

*Curator, Division of Mollusks, U. S. National Museum*

AND

HARALD ALFRED REHDER

*Assistant Curator, Division of Mollusks, U. S. National Museum*

(WITH FIVE PLATES)

During President Franklin D. Roosevelt's cruise in the Pacific and Atlantic Oceans in 1938, on board the U.S.S. *Houston*, Dr. Waldo L. Schmitt, Curator of the Division of Marine Invertebrates of the United States National Museum, served as Naturalist. Among other things he made collections of mollusks in many rarely visited places, which resulted in the discovery of a new subgenus and a number of new species and subspecies, which are here described.

We also give a list of all the species collected, believing this to be of especial interest, since little is known of the marine fauna of the places in which they were obtained.

A particularly interesting fact presented by these collections is the Indo-Pacific relationship of the marine mollusks of Clipperton Island, which suggests a drift fauna.

**TEREBRA (SUBULA) ROOSEVELTI, n. sp.**

Plate I, fig. 6

Shell of medium size, elongate-turritid; ground color yellowish on the early whorls, gradually passing into brilliant dark orange on the middle turns, again paling on the last whorl. The last 5 whorls have the part posterior to the groove marked by areas of blackish chestnut brown, which are of varying length; a little distance anterior to the groove a line of dots of the same color of varying size and spacing is present. The last whorl also has three rather broad, somewhat interrupted zones of pale brown separated by narrow paler lines; both of these elements are of about equal width, the darker bands being about two and one-half times as wide as the light lines. The first of these pale brown bands is immediately above the periphery, the second is

immediately above the basal angle, and the last is on the anterior half of the base. The outside of the columella is of the same color as the base; its inside, as well as the inside of the aperture, is yellowish, the outer lip showing the darker bands, described for the exterior, within. Nuclear whorls decollated. The postnuclear whorls are encircled by a deeply impressed groove at about two-fifths of the distance between their summit and the periphery anterior to the summit. They are crossed by low broad axial ribs, which in turn, as well as the intercostal spaces, are marked by fine incremental lines. Of these ribs 33 are present on the last whorl. The spiral sculpture is reduced to microscopic striations. The suture appears as deeply impressed as the groove anterior to it. Periphery well rounded. Base short, well rounded, marked by the continuations of the axial ribs and fine incremental lines, which extend to the columella. Columella short, thick, with a strong oblique fold which is separated from the base by a decided groove. Anteriorly to the fold the columella is somewhat twisted and marked by strong incremental lines. On the inside the columella shows a second low rounded fold bordering its anterior termination. Aperture auriculate, decidedly channeled anteriorly, the outer lip thin, somewhat contracted above the groove posteriorly.

The type, U.S.N.M. no. 472534, has 12.5 whorls remaining and measures: Length, 43.2 mm.; greater diameter, 14.1 mm.; lesser diameter, 14.0 mm. It was dredged on Socorro Island, Mexico, in 7-8 fathoms on sandy bottom, off the landing beach toward the rocky point forming the east side of the cove.

**APLYSIA CEDROSENSIS, n. sp.**

Plate 4, figs. 8-10; plate 5

Animal large, stout, rather broad and high. The color (in alcohol) is arranged as follows: The head, the foot, the sides of the body, and the exterior of the pleuropodia (or lateral lobes) are black; the dorsal area is gray from the rhinophores to the posterior edge of the mantle, except for a black area extending posteriorly from between the rhinophores for an inch and a half and becoming narrower, and a narrow irregular black patch extending along the middorsal line anterior to and over the mantle; the interior of the pleuropodia are irregularly maculated with black, as is the area about the mouth and buccal appendages. The skin is strongly wrinkled, especially the sole of the foot, the head regions, and the exterior of the pleuropodia. The head bears rather broad, folded buccal appendages. The rhinophores or tentacles are elongately conic and noticeably slit. The foot is broad

and strongly wrinkled, widening somewhat posteriorly and blunt at both ends. The pleuropodia are rather short and well separated in front, united posteriorly, forming a wall about the branchial cavity and mantle about an inch high. The mantle covers the shell completely and has a minute pore in the center. The posterior edge of the mantle is somewhat sinused on the right side, with a short erect fleshy crest slightly anterior to the sinus. The genital pore is conspicuous, slightly crescentic, situated a short distance in front and to the right of the anterior edge of the mantle; a marked genital groove runs anteriorly from it to below the right buccal appendage. The shell is large, thin, chitinous, concave, shieldshape, with a moderately large shallow sinus at the top where the edge is slightly thickened and reflexed. A thin deciduous calcareous layer is present on the ventral surface.

The type, U.S.N.M. no. 472859, measures: Length, 165 mm.; width, 90 mm.; height, 85 mm. (This is, of course, an alcoholic specimen slightly distorted in the process of preserving.) The shell measures: Height, 76 mm.; width, 57 mm. It was collected on the east side of Cedros Island, Lower California, along the shore to the north and south of the cannery.

This species resembles the Peruvian species *Aplysia nigra* d'Orbigny in having the lateral lobes united posteriorly, though not to as great an extent, and in the posterior edge of the mantle being sinused and bearing a fleshy crest. All the species heretofore described from North and Central America have the pleuropodia free behind, not united. There is no tail visible in our specimen.

#### CONUS ROOSEVELTI, n. sp.

Plate 1, figs. 4, 7

Shell small, spire broadly conic, moderately elevated, sides of the main part slightly convex on the posterior two-thirds and slightly concave on the anterior third. The spire is flesh-colored with dark spots between the knobs. The body of the last whorl presents a complex color scheme. The general ground color is bright, light chestnut brown, with a pale, moderately broad, submedian zone. The low, rather broad, spiral cords bear elongated low white tubercles, whose long axis coincides with the spiral sculpture. Between these white tubercles there is usually, but not always, a dark, more or less round, chestnut brown spot. The interior of the outer lip is brilliant chestnut brown with a yellowish zone below the posterior angle, and a yellowish submedian band and a series of dark spots near the edge.

The early whorls are eroded and so do not reveal their sculpture. Those remaining have a series of heavy knoblike tubercles separated by spaces about as wide as the knobs, at the shoulder. Of these knobs 11 are present upon the last turn. The summit of the turns is marked by 6 low rounded spiral threads which vary in width and are separated by well-impressed lines. In addition, the spire is marked by well-developed incremental lines. The posterior half of the body of the last whorl is marked by rather wide and moderately deep grooves, which here separate low rounded spaces of double their width. From the middle anteriorly the relative width of the spiral grooves and cords changes, *i. e.*, the cords become narrow and more elevated, while the spaces between them widen and appear less incised, but all these spaces, whether the narrow incised grooves of the posterior part or the wider anterior fields, are crossed by numerous, strongly raised, hairlike threads, which extend feebly upon the spiral cords and which are more distantly spaced on the posterior portion than on the middle, and become decidedly crowded on the anterior third. Fourteen of the raised spiral bands are present between the shoulder and the columella. The columella bears 7 closely approximated, strong spiral cords. Aperture narrow, decidedly channeled anteriorly, scarcely so at the posterior angle; outer lip thin.

The type, U.S.N.M. no. 472854, measures: Length, 15.3 mm.; greater diameter, 9.6 mm.; lesser diameter, 8.5 mm. It was collected on Clipperton Island on rocks along the shore, south of the landing place. Two additional specimens bear U.S.N.M. no. 472549.

This species is a member of the *Conus miliaris* complex. It is darker than that species, the spiral grooves are more pronounced, and the nodulation is heavier.

**CONUS MAGDALENENSIS, n. sp.**

Plate 1, figs. 5, 9

Shell of medium size, with rather elevated spire with its lateral margins slightly concave and the sides almost straight. The narrow whorls on the spire are marked by alternating zones of dark brown and the flesh-colored ground color. The body of the whorls carries these alternating axial areas to the tip of the columella, but with an interruption produced by a spiral band of the ground color which encircles the turns almost at the middle between the shoulder and base. The dark chestnut-colored areas are in the form of broad fulgurations, some of whose points join those of adjacent zones. They are about as wide as the lighter areas separating them. Judging from the rem-

nants of the periostracum remaining, the living mollusk has its shell covered by a hairy golden coat. The inside of the aperture is bluish white, the inner edge of the outer lip showing a series of dark spots that have dark brown centers and paler edges. Early whorls eroded. The early turns of those remaining have a strong keel on the middle, which is produced by the fact that the summit of succeeding turns falls anterior to the shoulder. This keel is finely nodulose on the early whorls, the nodules gradually disappearing on the later turns. The keel itself becomes less marked on the later whorls where the summit of the succeeding turns approaches the angulated shoulder. The sculpture of the summit of the whorls consists of retractively curved incremental lines and some obsolete spiral striations. The sides of the last whorl are marked by lines of growth and obsolete spiral striations, which develop into rather strong low spiral cords on the basal third. Aperture narrow, decidedly channeled anteriorly and posteriorly; outer lip protracted in the middle.

The type, U.S.N.M. no. 472521, has 10 whorls remaining and measures: Length, 33.6 mm.; greater diameter, 15.3 mm.; lesser diameter, 13.7 mm. It was dredged in Magdalena Bay, Lower California, in 10-15 fathoms on sandy, weedy bottom, at the entrance to the bay between Belcher Point and the anchorage.

This cone is related to *Conus regularis* Sowerby, from which it is distinguished by its higher spire and the light median bands of the body whorl.

#### MARGINELLA ROOSEVELTI, n. sp.

Plate 1, figs. 2-3

Shell large, ovate, shining, dorsal part deep brilliant orange with two faint spiral bands of a paler shade, fading to flesh-color with an orange flush, on the ventral side. In addition to this, 5 reddish chestnut-colored spots are present, distributed as follows: 1 at the apex, 1 on the back of the columella a little above the lip, 1 on the middle of the base, 1, the largest, a little posterior to the middle of the outer lip, and the fifth, also strong, halfway between this and the basal spot. The outer lip is thickened and white, excepting the 2 spots. Aperture narrow, decidedly channeled anteriorly and slightly so at the posterior angle. The columella bears 4 oblique folds on its basal two-fifths. The entire surface is glassy and devoid of sculpture.

The type, U.S.N.M. no. 472610, comes from a tide pool at Old Providence and measures: Length, 23.0 mm.; greater diameter, 13.3 mm.; lesser diameter, 11.2 mm.

Its large size and dark coloration distinguish it from *Marginella guttata* and allied forms.

**ENGINA EARLYI, n. sp.**

Plate 1, fig. 8

Shell broadly ovate, blackish chestnut brown, excepting the intercostal spaces, which are chestnut brown; the aperture is of brilliant orange color with a dark spot on the upper portion of the columellar callus and a more elongate, narrower one on the edge of the middle of the columella. Early whorls badly eroded, the later ones with a series of humplike nodules that occupy the anterior two-thirds of the turns and extend over the base as axial ribs gradually diminishing in size toward the tip of the base. Of these humps 8 are present on the last turn. In addition to this sculpture, the whorls are marked by spiral threads of somewhat variable width and spacing; of these 10 are present between the summit and periphery on the last turn. The base is slightly concave on the left margin and is marked by 5 spiral series of knobs which gradually and uniformly diminish in size from the periphery anteriorly. These knobs are about as wide as the spaces that separate them and are arranged in axial series. The base also bears spiral threads, which extend over the knobs and intercostal spaces; rather strong incremental lines are also present. Aperture half as long as the shell, elongate pear-shaped, decidedly channeled anteriorly; outer lip very thick, bearing a weak denticle below the posterior angle, and 5 stronger, equally spaced, denticles occupying its middle; the inner lip also bears 3 denticles on its median portion and there is also a denticle on the parietal wall a little distance from the outer lip. The inner lip extends over half of the columella as a heavy callus, which also covers the parietal wall.

The type, U.S.N.M. no. 472566, has 5.5 whorls remaining and measures: Length, 12.5 mm.; greater diameter, 8.4 mm.; lesser diameter, 6.3 mm. It, and another specimen, U.S.N.M. no. 472855, were collected in a tide pool in Sullivan Bay, James Island, Galápagos. It is named for Mr. Stephen Early, Secretary to the President.

**NITIDELLA GUTTATA BAILEYI, n. subsp.**

Plate 2, fig. 6

Shell ovate, turrated, early whorls pale brown, the later dark blackish brown; base chestnut brown. The entire surface is dotted with round spots of pale orange. Interior of aperture bluish white with the

peristome edged with brown. The whorls increase regularly in size and are marked only by fine incremental lines, excepting the columella which bears 9 rather strong spiral cords, and 7 fine threads near the tip. Aperture ovate, strongly channeled anteriorly; outer lip thick, bearing 10 elongated denticles having their long axis parallel with the spiral plane. The inner lip partly excavates the columella and parietal wall, leaving it as a smooth porcelaneous surface. There is a humpish callus on the parietal wall near the posterior angle.

The type, U.S.N.M. no. 472857, has 11 whorls and measures: Length, 13.0 mm.; greater diameter, 5.1 mm.; lesser diameter, 4.4 mm. It and a series of specimens, U.S.N.M. no. 472586, were collected in Elizabeth Bay, Albemarle Island, Galápagos. U.S.N.M. no. 472583 contains 2 specimens collected on Narborough Island, Galápagos.

This form is much darker than the typical *Nitidella guttata* Sowerby, which comes from Panama.

This is named for Commander C. A. Bailey, Executive Officer of the U.S.S. *Houston*.

**TRITONALIA (OCINEBRINA) CARIBBAEA, n. sp.**

Plate 1, fig. 1

Shell small, very elongate-ovate, brown, with the spiral zone of tubercles above and below the peripheral keel and the 3 median columellar cords white. Aperture brown within with the external white bands marking the peristome; the denticles within the outer lip are also white. Nuclear whorls eroded. Postnuclear whorls marked by broad low axial ribs, of which 9 are present on the last turn; strong incremental lines also cross the whorls. The spiral sculpture consists of 3 very strong keels, which grow consecutively stronger from the first at the summit anteriorly. These cords pass across the intercostal spaces and the axial ribs, rendering these nodulose at their intersection. The nodules have their long axis coinciding with the spiral sculpture. Lesser spiral threads mark the spiral cords and the spaces between them. Suture moderately strongly constricted. Periphery with a spiral cord as strong as those posterior to it and similarly marked. Base short, well rounded with a heavy nodulose spiral cord on its middle and the finer sculpture noted for the spire. Columella long, somewhat twisted and marked by 2 slender spiral threads near its insertion, followed by 3 heavier cords, then a series of finer, more closely approximated threads near its tip. All this spiral sculpture is rendered roughened by incremental lines. Aperture decidedly chan-

neled anteriorly; outer lip thick, marked at the edge by incremental lines bearing 5 denticles within the edge in the expanded portion of the aperture; inner lip appressed to the columella in its posterior half, free on the anterior part. Parietal wall glazed with a thin callus except near the outer lip where it develops into a low hump.

The type, U.S.N.M. no. 472617, has a little more than 6 whorls remaining and measures: Length, 8.1 mm.; greater diameter, 4.1 mm.; lesser diameter, 3.4 mm. It was collected on Old Providence Island.

**ALVANIA NIGRESCENS, n. sp.**

Plate 2, fig. 5

Shell minute, elongate-ovate, dark chestnut brown, a little paler on the outer and basal lip. Nuclear whorls about 2, well rounded, smooth. Postnuclear whorls moderately rounded, marked by strong axial ribs which are about as wide as the spaces that separate them and which are rendered decidedly tuberculated by the 3 spiral cords at their junction. There are 17 of these ribs on the last whorl. The spaces enclosed between the axial ribs and spiral cords are rounded pits. Suture strongly constricted. Periphery marked by a spiral cord a little less strong than those of the spire, bearing feeble tubercles. Base well rounded, slightly excavated at the columella and marked by 4 spiral cords, of which the first below the periphery is stronger than the rest, which are of equal strength. In addition to this, the entire base is marked by incremental lines. Aperture subcircular. Peristome double; the outer is present only on the outer and basal lip, thick and marked by concentric striations; the inner is slightly exerted.

The type, U.S.N.M. no. 472621, has 5.5 whorls and measures: Length, 3.1 mm.; diameter, 1.5 mm.

It was collected in a tide pool on Old Providence Island.

**PEASIELLA ROOSEVELTI, n. sp.**

Plate 2, figs. 1-3

Shell small, broadly conic, with zigzag axial bands of blackish brown, alternating with bluish white bands of the same width. These bands terminate at the periphery in large alternating light and dark spots. The base is marked by a broad band of alternating dark and light spots adjoining the periphery and 2 similar bands on the keels; in the middle one, however, the light areas are feebly tinged with brown. The columellar region is also pale brown. The interior of the



outer lip is brown variegated at the edge with light spots, which coincide with the external light areas. There is a broad light-spotted zone on the inside of the basal lip and a light spot at the base of the columella. Nuclear whorls 2, too eroded to show sculpture. Post-nuclear whorls strongly rounded, marked by 4 strong spiral keels, of which the first is a little below the summit and the fourth at the periphery, the other 2 dividing the whorls into equal spaces. These keels are feebly tuberculated. Of these tubercles, 12 are present upon the last whorl. In addition to this the entire surface of the whorls is marked by fine equal and equally closely spaced spiral threads, 47 of which are present between the summit and the periphery on the last whorl. Suture moderately impressed. Periphery strongly keeled. Base short, moderately convex, openly umbilicated and marked by 3 strong spiral keels that divide it into 4 equal areas, the fourth constituting the umbilicus. The 2 posterior keels are broad and rounded; the third, which borders the umbilicus, is sharp and more elevated. The entire base is also marked by spiral threads, of which about 35 are present between the periphery and the umbilical keel. On the base the incremental lines are a little more strongly developed than on the spire and furnish in combination with the spiral threads a suggestion of a reticulated pattern. The umbilical wall is marked by lines of growth only. Aperture broadly ovate; outer lip very strongly arched, thin at the edge, posterior half of columella straight, flattened, and decidedly expanded and flattened on the outer half. The parietal wall is covered by a thin callus.

The type, U.S.N.M. no. 472575, has 4.5 whorls and measures: Length, 3.2 mm.; greater diameter, 3.0 mm. It was collected in a tide pool in Sullivan Bay, James Island, Galápagos.

**LITTORINA SCHMITTI, n. sp.**

Plate 2, fig. 4

Shell broadly ovate with sharply pointed apex. The ground color is blackish chestnut with narrow spiral lines of white marking the grooves and more or less zigzag axial lines of white. On the base the white spiral lines are also present and white axial lines produce a checkerboard pattern. The outer edge of the columella is bright chestnut brown, a suffusion of which covers the parietal wall. The deep portion of the posterior half of the columella and the deep callus on the anterior half of the parietal wall are porcelain white with faint chestnut suffusion at the edge. The inside of the outer lip is marked by alternate spiral zones of dark chestnut brown separated by whitish

lines. Nuclear whorls exceedingly small, apparently smooth. The early postnuclear turns have 4 deep spiral grooves, which are of equal width and which separate the intervening spaces into 5 equal rounded cords, the first of which is at the summit. On the succeeding turns the incised spiral lines become less strong, and the spaces between them are broad, slightly rounded zones. Of these incised spiral grooves, 6 are present between the summit and the suture on the last whorl, and 4 more between the suture and the basal angle. In addition to this the whorls are marked by fine incremental lines and closely crowded microscopic spiral striations. Suture moderately conspicuous. Periphery obtusely angulated. Base marked by 8 equal and equally spaced incised spiral lines and the continuations of the same finer sculpture mentioned for the spire. Aperture broadly ovate, somewhat effuse at the junction of the basal lip and columella, and decidedly acute at the posterior angle; outer lip strongly arched and thin. Operculum moderately thin, corneous, having a little more than 3 whorls with excentric nucleus marked by fine incremental lines.

The type, U.S.N.M. no. 472547, a male, has 7.4 whorls and measures: Length, 11.8 mm.; greater diameter, 8.2 mm.; lesser diameter, 6.5 mm. It, and a series of specimens, U.S.N.M. no. 472546, were collected at Clipperton Island on rocks at the shore south of the landing.

This species presents sexual dimorphism, the females being much larger. Large old specimens are usually badly eroded and fail to show the splendid color pattern displayed in the type. A large female has 5.3 whorls and measures: Length, 18.2 mm.; greater diameter, 11.8 mm.; lesser diameter, 10.5 mm.

This species is related to the Hawaiian *Littorina pintado* Wood, but is easily distinguished from this by its darker color and by having the spiral grooves less deep and more distantly spaced.

It is named for Dr. Waldo L. Schmitt, its discoverer.

#### **HIPPONIX FIMBRIATA, n. sp.**

Plate 2, figs. 7-9

Shell cup-shaped, *i. e.*, irregularly broadly conic, pale yellow, covered by a pale golden-yellow, much fimbriated periostracum. Interior porcelain white. The nucleus is very small consisting of a little more than 1 whorl, which is well rounded and microscopically granulose. The postnuclear part increases very rapidly in size and loses its coiling, forming a broadly flaring cuplike structure, whose exterior is marked by a series of concentric lamellae, whose edges are more or less free and somewhat fimbriated. The ventral margin, *i. e.*, peri-

stone, is rather broad with concentric lines. The interior is smooth, except the well-impressed muscle scar.

The type, U.S.N.M. no. 472853, measures: Length, 5.5 mm.; greater diameter, 11.5 mm.; lesser diameter, 9.9 mm. It, and a series of specimens, U.S.N.M. no. 472551, were collected on Clipperton Island on rocks along the shore south of the landing place.

The basal aspect of this species recalls *Hippovix serrata* of the western United States shores, but this has the lamellations more crowded and more irregular and lacks the radial sculpture of that species.

**TEGULA (CHLOROSTOMA) BARKERI, n. sp.**

Plate 2, figs. 10-12

Shell small, broadly conic, of blackish brown ground color, with numerous dots of bluish white on the spiral cords and 6 distantly spaced, oblique axial zones of bluish white on the last whorl, which are of irregular outline and extend from the summit to the periphery. On the base the spiral cords are marked by alternate elongate zones of light and dark, which are also arranged in a somewhat axial series. The spaces between the spiral cords and the immediate area near the umbilicus on the base are pale. The columella and parietal callus are strikingly bright jade green, and the interior of the outer lip is pearly gray. Nuclear whorls badly eroded. Postnuclear whorls well rounded, marked by strong, well-rounded and elevated cords, of which 4 are present upon the first, 5 upon the second, 7 upon the third, and 8 upon the last between the summit and the periphery. The cords, as well as the deep spaces that separate them, are marked by numerous, closely spaced hairlike, retractively slanting, axial threads, which are best shown in the grooves. Suture somewhat channeled. Periphery well rounded. Base moderately convex, openly umbilicated and marked by 11 spiral cords which are not quite equal or equally spaced; here also the fine axial threads are present. The umbilical wall is smooth excepting a submarginal spiral cord. Aperture subcircular, decidedly oblique; the strongly arched outer lip is rendered crenulated by the external sculpture; the inner lip is decidedly sinuous and bears a double denticle at the base of the columella; a lesser one is present a little anterior to these on the basal lip.

The type, U.S.N.M. no. 472589, has 5.2 whorls and measures: Length, 7.4 mm.; greater diameter, 9.4 mm.; lesser diameter, 7.7 mm. It and a little older specimen, U.S.N.M. no. 472856, were collected at

Elizabeth Bay, Albemarle Island, Galápagos. The larger specimen measures: Length, 8.6 mm.; greater diameter, 10.7 mm.; lesser diameter, 9.2 mm.

This species is related to *Tegula* (*Chlorostoma*) *snodgrassi* Pilsbry and Vanatta, which comes from Albemarle Island. It is, however, more depressed and of darker color with fewer light zones.

It is named for Capt. G. N. Barker, of the U.S.S. *Houston*.

#### PHLYCTIDERMA, n. subgen.

Shell similar to *Entodcsma* but anteriorly more narrow, with the anterior half of the ventral margin more sinuous, and with surface sculptured with very fine, radially arranged, white pustules which become obsolete toward the margins.

*Type*.—*Lyonsia* (*Phlyctiderma*) *lucasana*, new species.

#### LYONSIA (PHLYCTIDERMA) LUCASANA, n. sp.

Plate 4, figs. 1-3

Shell of medium size, elongate, inflated, ventrally gaping, anteriorly subrectangular, posteriorly broader and more rounded. The anterior end is inflated and blunt, the area anterior to and below the umbones being somewhat concave. The umbones are rather prominent and almost terminal, and the anterior end from the umbones to the anterior ventral angle is about straight. The ventral margin is strongly sinuous anteriorly. The surface is white, covered with a thin pale brown periostracum arranged anteriorly in irregular vertical stripes coalescing posteriorly into a more solid patch; the whole surface is covered with radially arranged fine white tubercles evanescent toward the margins. The grosser sculpture consists of rounded concentric ridges crossed posteriorly by a few distant, low radial ridges occasionally bifurcating; toward the posterior and ventral margin the sculpture becomes rather irregular. Interior pearly, with an oval anterior muscle scar and a bipartite posterior muscle scar, the lower part being larger and suborbicular. Hinge teeth lacking; a narrow shelf for the ligament is present just below the dorsal edge posterior to the umbones.

The type, U.S.N.M. no. 472526, a single left valve, measures: Height, 9.9 mm.; length, 18.5 mm. It was dredged in 6-10 fathoms off Punta Gorda, Cape San Lucas, Lower California, Mexico.

This species seems closest in general appearance to *Lyonsia* (*Ento-*

*desma?*) *picta* Sowerby described from the Isla Muerte, Ecuador, but the color markings of this species are black on a brown base. Whether this species has the granular sculpture is not known.

**CHAMA RUBROPICTA, n. sp.**

Plate 3, figs. 6-10

Shell small, suborbicular, the left valve sessile and sharply angulate so that the anterior part is affixed to the substratum, and the posterior part rises vertically from the base. The left valve is distantly lamellose and fimbriated where it is attached; the rest of the surface shows irregular, discontinuous vertical ridges which are of an orange-scarlet color on a ground which is of a very pale pinkish blush, except near the base, where it is white; there are also present scattered lamellose spines. The right valve is slightly convex, closely fimbriately lamellose, with occasional semitubular or lamellose spines, and of a general scarlet color, except near the anterior dorsal edge, where it is white. The interior of the right valve is vivid scarlet, except for a white anterior portion; the left valve is white inside with a narrow pale orange-scarlet stripe running from the umbonal region to the dorsal edge. The left valve has a rather short stout cardinal tooth which is grooved on the dorsal edge; the right valve has a somewhat longer, narrower cardinal. The ligament is posterior to the umbones, slender and curved. The margins of both valves are denticulate, and the affixed portion of the left valve shows crowded low radial grooves which terminate at the marginal crenulations.

The type, U.S.N.M. no. 472553, measures: Height, 11 mm.; length, 9.1 mm. It was collected on rocks to the south of the landing place on Clipperton Island.

**CTENA CLIPPERTONENSIS, n. sp.**

Plate 3, figs. 1-5

Shell white, broadly transversely oval to subcircular, moderately inflated, with the umbones prominent and anterior to the middle. The anterior end is slightly flattened, the posterior end broadly rounded. Lunule broadly ovate. The sculpture consists of a few, closely spaced, rounded radial riblets, crossed by crowded concentric rounded lamellae, which render the riblets nodulose; the radial and concentric sculpture is of equal strength and is only brought out clearly under magnification. The interior is white with the muscle scars well defined, the anterior one being suborbicular, the posterior one elongate

and suberescence. The ligament is rather stout and lies in a deep groove which runs from the umbones halfway to the anterior end. The hinge of the left valve consists of a stout cardinal with a much smaller cardinal posterior to it and partly fused with the dorsal margin; there is a stout pointed posterior lateral and a smaller anterior lateral, both separated from the margin of the shell by more or less deep grooves. The right valve has a short cardinal with a smaller one anterior to it and partly fused to the ligamental nymph; the laterals are paired, the larger pointed one on the inside, and the smaller one near the margin, the two separated by a deep groove: the posterior laterals are somewhat stouter than the anterior ones.

The type, U.S.N.M. no. 472552, measures: Height, 13.7 mm.; length, 14.7 mm.; diameter, 7.8 mm. It was collected on Clipperton Island, on rocks to the south of the landing place.

This species differs from the Hawaiian *Ctena bella* Conrad and its Pacific analogs by being not as orbicular and by possessing far less conspicuous sculpture, both the radial and concentric sculpture being lower, more obscure, and of equal strength.

#### BRACHIDONTES MULTIFORMIS HOUSTONIUS, n. subsp.

Plate 4, figs. 4-7

Shell small, inflated, elongately triangular, the umbones anterior, terminal, the dorsal margin straight, slightly compressed, the ventral side broad and somewhat concave, the posterior portion broad and rounded. The color is deep blackish purple, except for the ventral side and for some distance posterior to the umbones, where the shell is yellowish olive green. The prodissoconch is a smooth, elongate, rectangular purplish shell. Following this the shell is ornamented with many fine radial riblets separated from each other by spaces as wide as the riblets, and crossed by finer concentric lirae, which render the ribs distinctly nodulose in the earlier half of the shell's growth; in the later half the spiral sculpture becomes more or less obscure and the radial ribs consequently lose their pronounced nodulousness. The interior is a purplish blue, except toward the ventral margin, where it is bluish white. At the anterior end are two purple tubercles, the upper one considerably larger than the lower one. The dorsal margin is strongly denticulate, the denticulations increasing in size toward the posterodorsal angle. The anterior part of the ventral margin, and the posterior margin are crenulated by the ends of the radial ribs. The ligament lies on a long, rather deeply situated shelf.

The type, U.S.N.M. no. 472858, measures: Height, 5.9 mm.; length, 8.9 mm.; diameter, 4.9 mm. It, and three other specimens,

U.S.N.M. no. 472580, were collected along the shore in Sullivan Bay, James Island, Galápagos Islands.

This is the finely sculptured race that inhabits the Galápagos Islands, the typical *Brachidontes multiformis* Carpenter from Panama being more coarsely sculptured.

**Cedros Island, Lower California, Mexico.**

Collections were made on the east side of the island, along the shore, north and south of the cannery, July 17, 1938.

*Aplysia cedrosensis*, new species  
*Littorina planaxis* Philippi  
*Acmaca limatula* Carpenter  
*Nuttalina fluxa* Carpenter  
*Brachidontes stearnsianus* Pilsbry and Raymond

**Magdalena Bay, Lower California, Mexico.**

The specimens were dredged inside the north point of the entrance to the bay, between Belcher Point and the anchorage in 10–15 fathoms on sandy, weedy bottom, July 18, 1938.

*Comus magdalensis*, new species  
*Strombina gibberula* Sowerby  
*Crucibulum spinosum* Sowerby (young)  
*Crepidula arenata* Broderip  
*Crepidula nummaria* Gould  
*Lucapinella callomarginata* Carpenter  
*Transenella puella* Carpenter  
*Lacvicardium clenense* Sowerby

**Cape San Lucas, Lower California, Mexico.**

The specimens were dredged off Punta Gorda in 6–10 fathoms, and in San Jose del Cabo Bay, July 19, 1938.

*Fissurella rugosa* Sowerby  
*Lyonsia (Phlyctiderma) lucasana*, new species  
*Tivela delesserti* Deshayes  
*Chama corrugata* Broderip  
*Cardita affinis* Sowerby  
*Septifer cumingii* Dunker

**Socorro Island, Mexico.**

Collections were made along shore at the landing place in Braithwaite Bay, July 20, 1938.

*Bulla punctulata* A. Adams  
*Terebra roosevelti*, new species

*Olivella dama* Mawe  
*Nitidella guttata* Sowerby  
*Cerithium uncinatum* Gmelin  
*Cerithium gemmatum* Hinds  
*Cardita crassicosata* Valenciennes? (young)  
*Tivcla delesserti* Deshayes (young)  
*Chione undatella* Sowerby  
*Cardium pristipleura* Dall (young)  
*Melina janus* Carpenter

#### Clipperton Island, Pacific Ocean.

Collections were made on the rocks to the south of the landing place, July 21, 1938.

*Opcas opanum* Pfeiffer  
*Conus roosevelti*, new species  
*Morula nodus* Bory St. Vincent (young)  
*Magilus robillardi* Lienard  
*Drupa vicina* Linné  
*Hipponix fimbriata*, new species  
*Hipponix barbata* Sowerby  
*Littorina schmitti*, new species  
*Nerita plicata* Linné  
*Ctena clippertonensis*, new species  
*Chama rubropicta*, new species  
*Acar* species? (young)

#### James Island, Galapagos Islands.

Collections were made along shore and in tide pools in Sullivan Bay, July 24, 1938.

*Onchidella steindachneri* Semper  
*Conus nux* Broderip  
*Persicula phrygia* Sowerby  
*Alvania duncani* Bartsch  
*Rissoina* species? (young)  
*Engina* species?  
*Engina carleyi*, new species  
*Engina panamensis* Bartsch  
*Latirus tuberculatus* Broderip  
*Cantharus ringens* Wood  
*Cantharus sanguinolentus* Duclos  
*Coralliophila costata* Blainville? (young)  
*Coralliophila parva* E. A. Smith  
*Purpura columellaris* Lamarck  
*Purpura patula* Linné  
*Purpura crassa* Blainville  
*Vermetus* species (fragment)  
*Cerithium adustum* Kiener



*Peasiella roosevelti*, new species  
*Hipponix barbata* Sowerby  
*Cheilea corrugata cepacea* Broderip  
*Melina quadrangularis* Reeve  
*Brachidontes multiformis houstonius*, new subspecies  
*Septifer cumingianus* Dunker  
*Barbatia reeveana* d'Orbigny

**Narborough Island, Galápagos Islands.**

Collections were made along the shore, July 25, 1938.

*Nitidella guttata baileyi*, new subspecies  
*Columbella fuscata* Sowerby  
*Columbella castanea* Sowerby  
*Cerithium adustum* Kiener

**Albemarle Island, Galápagos Islands.**

Shells taken from the anchor chain in Tagus Cove, in 50 fathoms, July 26, 1938.

*Fusinus dupetitthouarsi* Kiener (young)

**Albemarle Island, Galápagos Islands.**

Collections were made in Elizabeth Bay at the south end of the black beach, north of the mangroves, north of the two "red" islands, July 26, 1938.

*Onchidella steindachneri* Semper  
*Bulla* sp. (broken)  
*Columbella castanea* Sowerby  
*Nitidella guttata baileyi*, new subspecies  
*Purpura columellaris* Lamarck  
*Purpura patula* Linné  
*Tegula (Omphalius) cooksoni* E. A. Smith  
*Tegula (Chlorostoma) snodgrassi* Pilsbry and Vanatta  
*Tegula (Chlorostoma) barkeri*, new species  
*Chiton (Radsia) sulcatus* Wood

**Charles Island, Galápagos Islands.**

The specimens were collected by the crew along the shore of Post Office Bay, July 27, 1938.

*Bulimulus (Naesiotus) ustulatus* Sowerby  
*Bulimulus (Naesiotus) nux* Broderip  
*Conus diadema* Sowerby  
*Conus purpurascens* Broderip  
*Purpura patula* Linné  
*Chiton (Radsia) goodallii* Broderip

## Cocos Island, Costa Rica.

Bottom sample, Chatham Bay, August 3, 1938.

*Marginella minor* C. B. Adams  
*Lithophaga attenuata* Deshayes

## Old Providence Island.

The specimens were dredged in 7-8 fathoms, August 6, 1938.

*Columbella mercatoria* Linné  
*Murex (Phyllonotus) pomum* Gmelin  
*Strombus gigas* Linné (young)  
*Modulus modulus* Linné  
*Cerithium algicola* C. B. Adams  
*Cerithium literatum* Born  
*Alaba terraricosa* C. B. Adams  
*Tegula (Omphalius) fasciata* Born  
*Astraca brevispina* Lamarck  
*Astraca longispina* Lamarck  
*Ctena orbiculata* Montagu (young)  
*Trachycardium muricatum* Linné  
*Navicula zebra* Swainson (young)

## Old Providence Island, Caribbean Sea.

Shore, reef, and tide-pool collecting, August 6, 1938

*Marginella (Volvaria) arena* Kiener  
*Marginella roosevelti*, new species  
*Anachis pulchella* Blainville  
*Columbella mercatoria* Linné  
*Nassarius consensa* Ravenel  
*Tritonalia (Ocinebrina) caribbaca*, new species  
*Purpura deltoidea* Lamarck  
*Strombus costatus* Gmelin  
*Strombus gigas* Linné  
*Alvania nigrescens*, new species  
*Rissoina dubiosa* C. B. Adams  
*Hippoxix antiquata* Linné  
*Cerithium minimum* Gmelin  
*Cerithium algicola* C. B. Adams  
*Tegula (Omphalius) fasciata* Born  
*Tegula (Chlorostoma) indusii* Gmelin  
*Astraca longispina* Lamarck  
*Livona pica* Linné  
*Chama macrophylla* Gmelin  
*Pinna carnea* Gmelin  
*Isognomon listeri* Hanley  
*Acar conradiana adamsi* E. A. Smith  
*Navicula umbonata* Lamarck (young)  
*Barbatia barbata* Linné

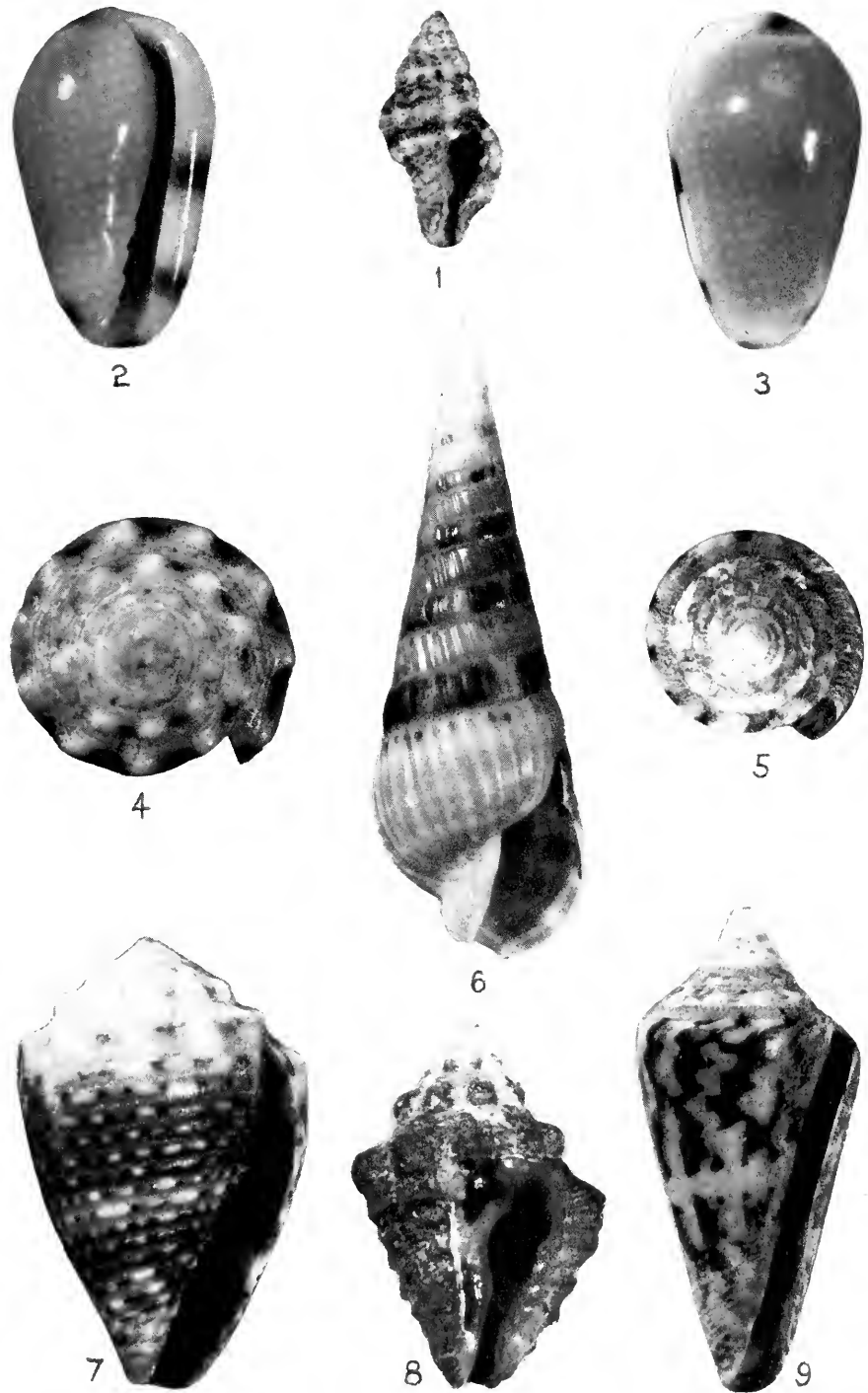

NEW SPECIES OF MOLLUSKS

- |  |                                       |
|--|---------------------------------------|
| 1. <i>Tritonalia (Ocinebrina) caribbaea</i> , n. sp. | 6. <i>Terebra roosevelti</i> , n. sp. |
| 2-3. <i>Marginella roosevelti</i> , n. sp.           | 7. <i>Conus roosevelti</i> , n. sp.   |
| 4. <i>Conus roosevelti</i> , n. sp.                  | 8. <i>Engina carlyi</i> , n. sp.      |
| 5. <i>Conus maadalcensis</i> , n. sp.                | 9. <i>Conus maadalcensis</i> , n. sp. |



1

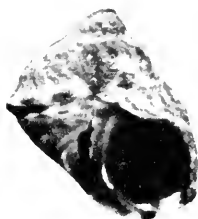

2



3



4



5



6



7

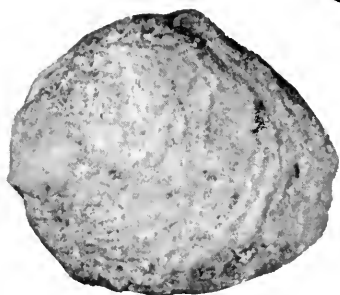

8

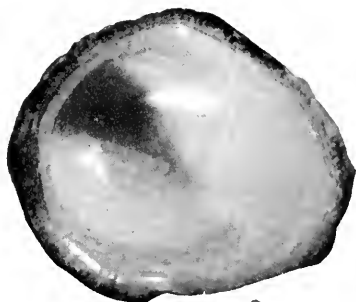

9

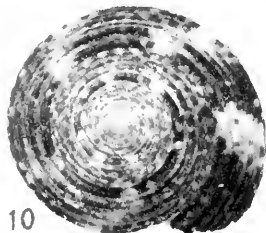

10

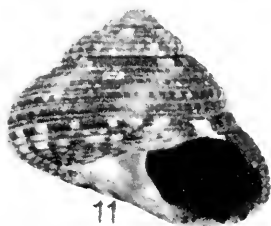

11

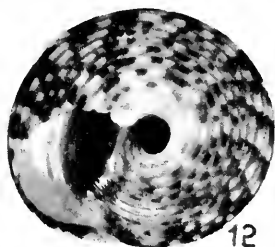

12

NEW SPECIES OF MOLLUSKS

1-3, *Peasiella roosevelti*, ♀ 10.  
4, *Littorina schmitti*, ♀ 4.  
5, *Alvania nigrescens*, ♀ 10.

6, *Nitidella guttata baileyi*, ♀ 4.  
7-9, *Hippoxis fimbriata*, ♀ 4.  
10-12, *Tenula (Chlorostoma) barkeri*, ♀ 4.

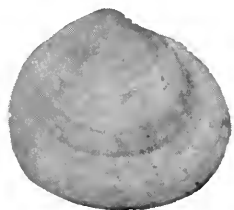

1



2



3

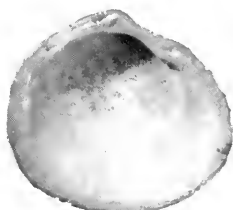

4

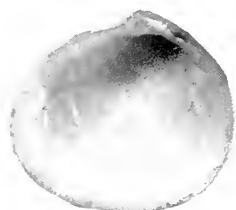

5

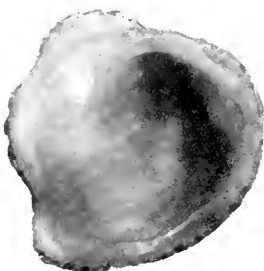

6

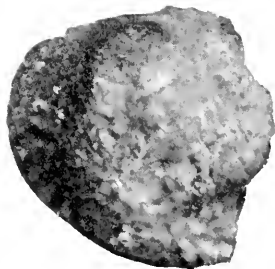

7



8

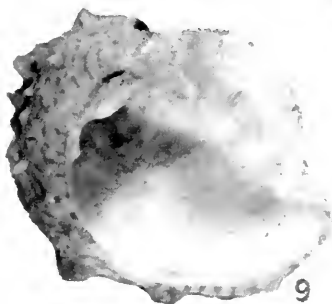

9

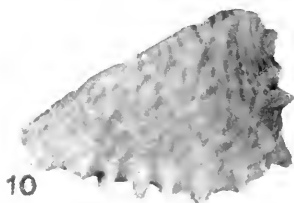

10

NEW SPECIES OF MOLLUSKS

1-2, 4-5, *Clena clippertonensis*, 2.  
 3, *Clena clippertonensis*, detail of sculpture. 10.  
 6-10, *Chama rubropicta*, 4.

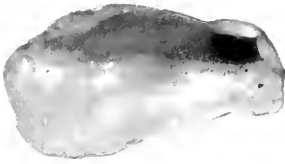

1



2

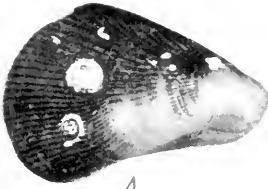

4

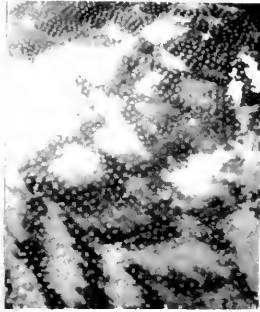

3

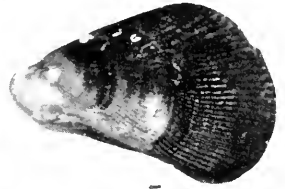

5

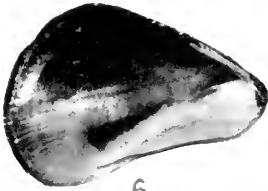

6

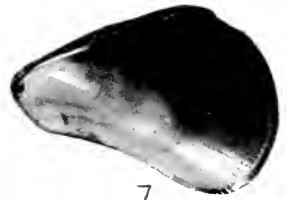

7



8



9



10

## NEW SPECIES OF MOLLUSKS

- 1, 2. *Lyonsia* (*Phlyctiderma*) *lucasana*, 2.  
 3. *Lyonsia* (*Phlyctiderma*) *lucasana*, detail of sculpture, 10.  
 4, 7. *Brachidontes multififormis houstonis*, n. subsp., 4.  
 5, 6, 9, 10. *Aplysia setrosensis*, shell, natural size.

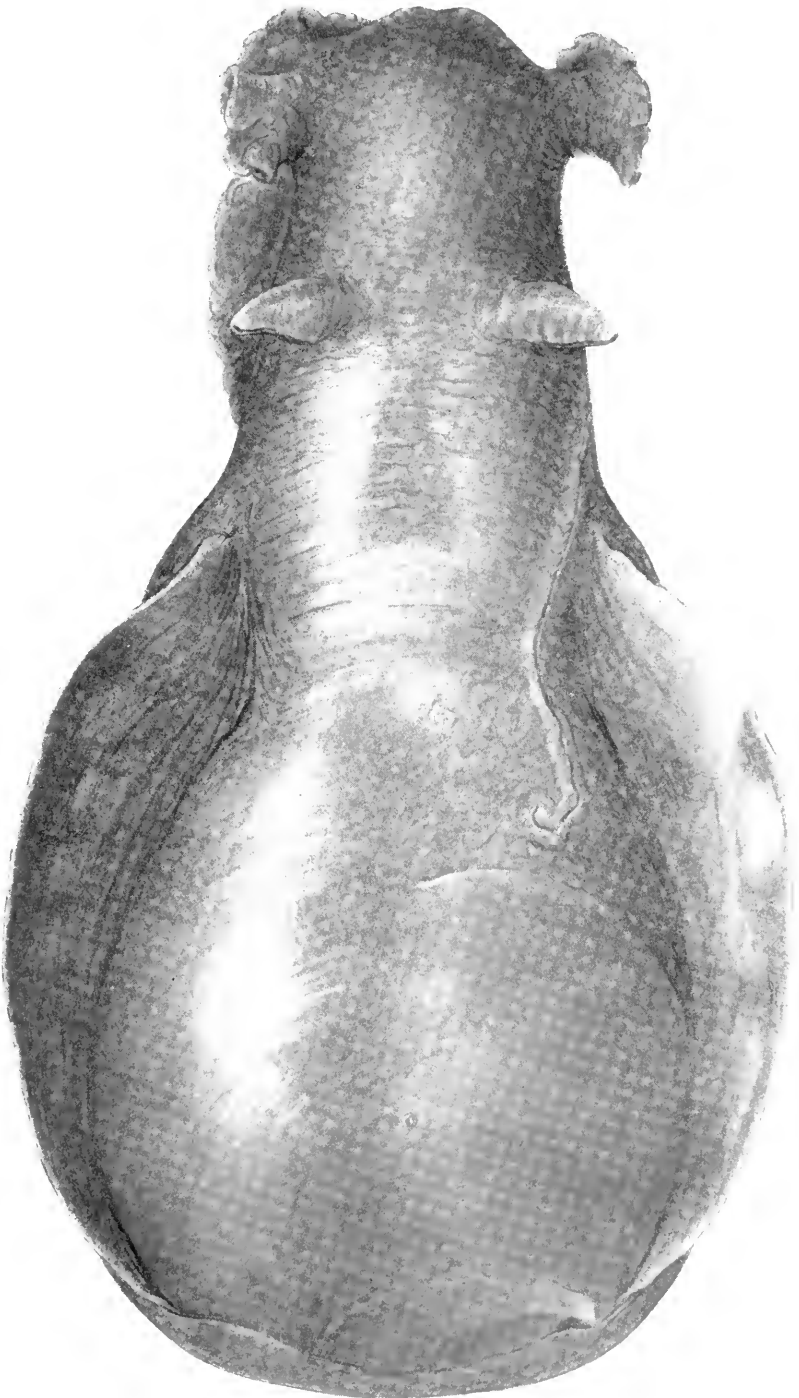

NEW SPECIES OF MOLLUSKS

*Aplysia colosensis*, natural size.





SMITHSONIAN MISCELLANEOUS COLLECTIONS

VOLUME 98, NUMBER 11

ECHINODERMS (OTHER THAN HOLOTHURIANS)  
COLLECTED ON THE PRESIDENTIAL  
CRUISE OF 1938

(WITH FIVE PLATES)

BY

AUSTIN H. CLARK

Curator, Division of Echinoderms,  
U. S. National Museum



(PUBLICATION 3536)

CITY OF WASHINGTON  
PUBLISHED BY THE SMITHSONIAN INSTITUTION

JUNE 2, 1939

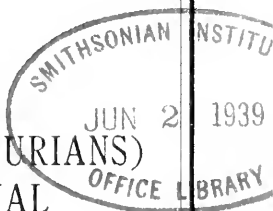



SMITHSONIAN MISCELLANEOUS COLLECTIONS  
VOLUME 98, NUMBER 11

ECHINODERMS (OTHER THAN HOLOTHURIANS)  
COLLECTED ON THE PRESIDENTIAL  
CRUISE OF 1938

(WITH FIVE PLATES)

BY

AUSTIN H. CLARK

Curator, Division of Echinoderms,  
U. S. National Museum



(PUBLICATION 3536)

CITY OF WASHINGTON  
PUBLISHED BY THE SMITHSONIAN INSTITUTION  
JUNE 2, 1939

The Lord Baltimore Press  
BALTIMORE, MD., U. S. A.

ECHINODERMS (OTHER THAN HOLOTHURIANS)  
COLLECTED ON THE PRESIDENTIAL  
CRUISE OF 1938

BY AUSTIN H. CLARK

*Curator, Division of Echinoderms, U. S. National Museum*

(WITH FIVE PLATES)

During the cruise of the U.S.S. *Houston* with President Roosevelt on board in the summer of 1938 Dr. Waldo L. Schmitt, who participated in the expedition as Naturalist, obtained specimens of 23 species of echinoderms other than holothurians. Although small, this collection is remarkable in including three new species, as well as representatives of several very rare species.

From Clipperton Island come numerous specimens of a curious small ophiuran that appears to be identical with one described from Mer in the Murray Islands, Torres Strait, by Dr. Hubert Lyman Clark in 1915 under the name of *Ophiocoma parva*. In 1921 Dr. Clark compared *Ophiocoma parva* with the 6-armed young of the West Indian *O. pumila*, which it very closely resembles. He said it seems probable that *O. parva* is the young of a larger 5-armed species.

The discovery of *O. parva* on Clipperton Island, where, as in Torres Strait, no species related to *O. pumila* is known to occur, led to an examination of the relationships between *O. parva*, and a related species from the Galápagos Islands, with *O. pumila*.

It was found that these species are closely related to the 6-armed individuals assumed to be the young of *O. pumila*. But these 6-armed individuals show such marked differences from 5-armed *O. pumila* of approximately the same size that they certainly cannot represent the same species.

I have, therefore, segregated *Ophiocoma parva*, the related species from the Galápagos Islands, and the related species from the West Indies hitherto assumed to be the 6-armed young of *O. pumila*, in the new genus *Ophiocomella*, a genus closely allied to, though apparently quite distinct from, *Ophiocoma*.

The species recorded in the following pages are listed below; the four herein described as new are given in small capitals.

<i>Ophiomyxa flaccida</i>	<i>Ophioderma appressa</i>
<i>Amphiodia violacea</i>	<i>Echinaster parvispinus</i>
<i>Amphipholis squamata</i>	<i>Heliaster cumingi</i>
<i>Ophiactis simplex</i>	<i>Sclerasterias</i> , sp.
<i>Ophiactis savignyi</i>	<i>Euclidaris thouarsii</i>
<i>Ophiothrix ørstedii</i>	HESPEROCIDARIS HOUSTONIANA
<i>Ophiothrix galapagensis</i>	<i>Lytechinus semituberculatus</i>
<i>Ophiocoma scolopendrina</i>	<i>Caenocentrotus gibbosus</i>
<i>Ophiocomella parva</i>	<i>Echinometra lucunter</i>
OPHIOCOMELLA CARIBBAEA	<i>Echinometra insularis</i>
OPHIOCOMELLA SCHMITTI	<i>Encope perspectiva</i>
OPHIONEREIS ROOSEVELTI	<i>Encope micropora</i>

Of the new species three are from the Galápagos Islands; the fourth, *Ophiocomella caribbaea*, heretofore regarded as the 6-armed young of *Ophiocoma pumila*, is from the West Indies.

Dr. Hubert Lyman Clark has been so kind as to give me his opinion on the status of *Hesperocidaris houstoniana* and the three species of *Ophiocomella*, and Prof. Walter K. Fisher was so good as to examine the specimen listed as *Sclerasterias*, sp.

## OPHIUROIDEA

### OPHIOMYXA FLACCIDA (Say)

*Locality*.—Old Providence Island, 120 miles east of the Mosquito Coast (lat.  $13^{\circ} 21' N.$ , long.  $81^{\circ} 22' W.$ ); shore; reef and tide-pool collecting; August 1, 1938. Two specimens (U.S.N.M. no. E.5612).

### AMPHIODIA VIOLACEA (Lütken)

*Locality*.—Cocos Island; Chatham Bay; from a bottom sample; August 3, 1938. One specimen (U.S.N.M. no. E.5626).

### AMPHIPHOLIS SQUAMATA (Delle Chiaje)

*Locality*.—Lower California: Cedros Island; about one-quarter of the way from the shore to the anchorage; from a bottom sample in 24-25 fathoms (44-46 m.); July 17, 1938. One specimen (U.S.N.M. no. E.5629).

### OPHIACTIS SIMPLEX (LeConte)

*Locality*.—Lower California: Magdalena Bay; 10-15 fathoms (18-27 m.); July 18, 1938. One specimen (U.S.N.M. no. E.5628).

**OPHIACTIS SAVIGNYI (Müller and Troschel)**

*Localities*.—Clipperton Island; shore collecting on rocks south of landing place; July 21, 1938. Five specimens, all with 6 arms, taken with *Ophiocomella parva* (U.S.N.M. no. E.5631).

Galápagos Islands: Sullivan Bay, James Island; shore and tide-pool collecting; July 24, 1938. One specimen with 6 arms (U.S.N.M. no. E.5627).

Galápagos Islands: Narborough Island; shore collecting; July 25, 1938. One specimen with 6 arms, taken with *Ophiocomella schmitti* (U.S.N.M. no. E.5641).

**OPHIOTHRIX ÖRSTEDII Lütken**

*Locality*.—Old Providence Island, 120 miles east of the Mosquito Coast (lat.  $13^{\circ}21'N.$ , long.  $81^{\circ}22'W.$ ); shore; reef and tide-pool collecting; August 1, 1938. Three specimens (U.S.N.M. no. E.5615).

**OPHIOTHRIX GALAPAGENSIS Lütken and Mortensen**

Plate 1, figs. 5, 6

*Localities*.—Galápagos Islands: Sullivan Bay, James Island; shore and tide-pool collecting; July 24, 1938. Ten specimens (U.S.N.M. nos. E.5613, E.5614, E.5630).

Galápagos Islands: Elizabeth Bay, Albemarle Island; south end of the black beach north of the mangroves north of the two "red" islands; July 26, 1938. Nine specimens (U.S.N.M. no. E.5642).

*Notes*.—In the specimens from James Island the disk is from 2.3 to 11.2 mm. in diameter, and the arms are from about 7 to about 55 mm. long.

In the specimen with the disk 2.3 mm. in diameter the central portion of the disk is occupied by a large circular central plate that is bare except for 5 stumps ending in 3 long divergent points interradially placed near the periphery. The exposed portion of the radials is relatively smaller than in larger examples, the radial shields extending only about half way from the periphery of the disk to the center, and each radial shield bears 5-8 stumps with triradiate ends resembling those borne on the small plates covering the remainder of the disk. At the base of the arm there are 6 arm spines, the number soon falling to 5 and later to 4; on the third and following arm combs the lowest spine is in the form of a hook, these hooked spines becoming very large in the outer portion of the arms.

In the largest specimen there are 11 arm spines just beyond the disk, the number soon falling to 8, later to 7, and then to 6 or 5. On the arm combs beyond the sixth-eighth the lowest spine is in the form of a hook.

The largest specimens from Albemarle Island have the disk 15 mm. in diameter and the arms 80 mm. long. Some are entirely blackish. In others the arms are narrowly banded with white on about every fourth upper arm plate, and the disk, except for the extreme edge, may be light or even cream-white.

#### OPHIOCOMA SCOLOPENDRINA (Lamarck)

*Locality*.—Clipperton Island; shore collecting on rocks south of landing place; July 21, 1938. One specimen (U.S.N.M. no. E.5619).

*Notes*.—In this specimen the disk is about 20 mm. in diameter and the arms are about 105 mm. long. The color above is uniform blackish brown, below the same, each under arm plate with a low white triangle of which the long base coincides with the proximal edge of the plate and the apex reaches nearly half way to the distal edge. These white triangles gradually decrease in size and disappear after about a dozen under arm plates. The proximal lower arm spines are tipped and sometimes longitudinally striped with white, and the mouth papillae are broadly tipped with white. The madreporic plate has a large white oval spot of which the outer end touches the distal border.

#### OPHIOCOMELLA, n. gen.

*Diagnosis*.—A genus of Ophiocomidae in which the included species are of small size, with the disk up to 5 mm. in diameter; the arms are 6 or 7 in number, from 3.25 to 5 times as long as the diameter of the disk; the disk is finely plated, shows very small and widely separated radial shields, and bears numerous scattered stout spinules that are from two to three times as long as thick, or even longer; and the arm spines are 4, subequal, or the uppermost the longest and the lowest the shortest, becoming 3 at the arm tips.

*Genotype*.—*Ophiocomella caribbaea*, n. sp.

*Included species*.—*Ophiocomella parva* (H. L. Clark), *O. caribbaea*, n. sp., and *O. schmitti*, n. sp.

*Range*.—Known from Mer Island, Torres Strait, Clipperton Island, the Galápagos Islands, and the West Indies. Littoral.

*Affinities*.—The genus *Ophiocomella* appears to be closely related to that section of the genus *Ophiocoma* including *O. pumila* from the Caribbean Sea and tropical west Africa, *O. alexandri* from the west



coast of Central America, and *O. valenciae* from the east coast of Africa and the Mascarene Islands. It is distinguished from this group of species by the possession of 6 or 7 arms; the occurrence on the disk of short stout spinules with usually pointed ends instead of elongated granules; by the occurrence of 2 tentacle scales (when present) on the first tentacle pore only; by the shape of the oral shields; and by the close approximation, or contact, of the adoral shields. The arm spines in preserved specimens of the species of *Ophiocomella* almost invariably stand out approximately at right angles to the arm, as in *Ophiactis*.

#### KEY TO THE SPECIES IN THE GENUS OPHIOMELELLA

- a*<sup>1</sup>. Spinules on upper surface of disk small and closely set, about 100 to each square millimeter (Torres Strait; Clipperton Island)..*parva* H. L. Clark.  
*a*<sup>2</sup>. Spinules on upper surface of disk coarser and more scattered, not more than 60 to each square millimeter  
*b*<sup>1</sup>. Spinules numerous, about 50-60 to each square millimeter, rather short and stout, mostly about twice as high as thick or rather lower, with usually rounded tips (West Indies).....*caribbaca*, n. sp.  
*b*<sup>2</sup>. Spinules relatively few, about 30-35 to each square millimeter, longer and more slender, mostly 3-4 times as long as thick with pointed ends (Galápagos Islands).....*schmitti*, n. sp.

#### OPHIOMELELLA PARVA (H. L. Clark)

Plate 1, figs. 1, 2

*Locality*.—Clipperton Island; taken in shore collecting on rocks south of the landing place; July 21, 1938. Forty-two specimens (U.S.N.M. nos. E.5639, E.5640).

*Notes*.—Of the 42 specimens collected, 39 have 6, and 3 have 7 arms. In the largest specimens the disk is 5 mm. in diameter and the arms are 17 mm. long.

In a number of specimens of different sizes the 3 arms on one side are from slightly to much smaller than the 3 arms on the other side, indicating that division takes place at various ages, and suggesting that it may occur more than once.

The radial shields are visible as small, narrow, elongate, widely separated plates, one on either side of the arm bases.

The first tentacle pore has usually a single tentacle scale, though in each individual one or more of these pores have 2 tentacle scales.

The adoral shields almost or quite meet beyond the inner end of the mouth shields.

The color in alcohol is white, the aboral side of the disk sometimes faintly tinged with green; the disk shows a brownish yellow patch at the base of each arm, and more or less coarse irregular mottlings of the same color; the arms are frequently and narrowly banded with brownish yellow, the bands occupying usually about 2 upper arm plates and being separated by usually 1 or 2 upper arm plates.

With these specimens of *Ophiocomella parva* were five specimens of *Ophiactis savignyi*.

*Remarks.*—Dr. Hubert Lyman Clark, to whom I sent one of these specimens of *Ophiocomella parva* for examination, writes that he is confident it is nothing but a young specimen of *Ophiocoma alexandri*. There is no evidence that *Ophiocoma alexandri* occurs at Clipperton Island and, indeed, such occurrence is quite unlikely, for *O. alexandri* has never been found in any locality inhabited by *O. scolopendrina*.

The National Museum possesses a young specimen of *Ophiocoma alexandri* with the disk about 2.3 mm. in diameter and the arms about 9 mm. long, and another with the disk 3.6 mm. in diameter and the arms about 15 mm. long, both collected by John Xantus at Cape San Lucas, Lower California (U.S.N.M. 1171). Both of these, which are considerably smaller than the largest specimens of *Ophiocomella parva*, have 5 arms, and they differ markedly from the specimens identified as that species.

In young *Ophiocoma alexandri* the granules on the disk are much coarser than they are in *Ophiocomella parva*, and are shorter with more swollen sides and more broadly rounded tips. Very small radial shields are visible, more or less concealed by one or more granules.

In young *Ophiocoma alexandri* the upper arm plates are more fan-shaped than in *Ophiocomella parva*—that is, they have straighter proximally convergent sides.

In *Ophiocoma alexandri* the arm spines are longer than in *Ophiocomella parva*, especially beyond the bases of the arms, and less rapidly tapering, and those on the proximal arm combs are less strongly flattened. The combs just beyond the disk in young *Ophiocoma alexandri* have usually 5 spines, those following 4, and those in the outer portion of the arms 3. In *Ophiocomella parva* the combs never have more than 4 arm spines.

The first two tentacle pores in young *Ophiocoma alexandri* have each 2 tentacle scales; in *Ophiocomella parva* the second and following pores have a single tentacle scale, and the first has usually a single scale, though sometimes 2.

The mouth shields in young *Ophiocoma alexandri* are broadly egg-shaped and about as long as the greatest (distal) width; in *Ophiocomella parva* they are rhombic with slightly rounded angles, and only half again as long as the greatest (median) width.

In young *Ophiocoma alexandri* the side mouth shields are widely separated from each other instead of being almost or quite in contact as in *Ophiocomella parva*.

Dr. Clark did not compare the specimen sent him with his specimens of *O. parva* from Torres Strait, and the description of that species is not sufficiently detailed to admit of accurate comparison. It is very likely that the specimens herein identified as *O. parva* in reality represent a different species; if this should prove to be the case I would suggest that that species be called *Ophiocomella clippertoni*.

#### OPHIOCOMELLA CARIBBAEA, n. sp.

*Ophiocoma pumila* (part) A. H. CLARK, Proc. U. S. Nat. Mus., vol. 86, No. 3056, p. 451 (station 28, U.S.N.M. no. 5559), pl. 54, fig. 3, Apr. 5, 1939 (the type specimen).

*Description.*—This species is very similar to *O. parva*. In the type specimen the disk is 4 mm. in diameter, and the 6 arms are about 13 mm. long. The 3 arms on one side are slightly larger than the 3 arms on the opposite side.

The plating on the aboral surface of the disk is somewhat coarser than is the case in *O. parva*, and the spinules are larger, less numerous, and more scattered. There are about 50-60 spinules to each square millimeter instead of about 100 as in *O. parva*. The spinules are mostly about twice as high as thick, or rather higher, swollen-conical with usually rounded tips, and are separated from each other by several times their basal diameter.

The first tentacle pore has 2 tentacle scales instead of only a single one as is usually the case in *O. parva*, but those following have only 1.

The mouth papillae, especially the outermost, are slightly narrower and less rounded than those of *O. parva*.

The adoral shields almost or quite meet beyond the inner end of the mouth shields.

The central portion of the interbrachial areas below, as in *O. parva*, bears a few widely scattered spiniform granules.

There are 4 arm spines until near the end of the arm, when the number falls to 3.

*Locality*.—Smithsonian-Hartford Expedition station 28; St. John, Virgin Islands; coral reef off Lagoon Point, on the west side of Coral Bay; W. L. Schmitt, April 6, 1937. One specimen (type, U.S.N.M. no. E.5559).

*Notes*.—This species has heretofore been considered the 6-armed young of *Ophiocoma pumila*, from which, however, it is quite distinct.

In a specimen of *Ophiocoma pumila* from Haiti with the disk 5 mm. in diameter and the 5 arms 28 mm. long, the arms are nearly six times as long as the diameter of the disk instead of only slightly more than three times as long as in *Ophiocomella caribbaea*.

The granulation of the disk is rather close, the granules, though somewhat irregularly placed, averaging about their own thickness apart. The granules show much diversity in size and shape, some being twice as thick as others. The smallest granules are approximately spherical; the largest, which are about half again as long as their greatest thickness, are conical with much swollen sides; most of them are intermediate between these two extremes, with more or less broadly rounded ends.

On the first 3 side arm plates beyond the disk there are 5 arm spines, of which the uppermost is the longest, and the lowest is the shortest. The number then falls to 4, and in the terminal portion of the arm to 3.

The first and sometimes also the second tentacle pore is provided with 2 tentacle scales.

The central portion of the interbrachial areas below is thickly covered with granules.

#### OPHIOCOMELLA SCHMITTI, n. sp.

Plate 1, figs. 3, 4

*Description*.—The disk is 3 mm. in diameter, and the arms are about 15 mm. long. This species differs from *O. parva* from Clipperton Island in having the elongate granules or stout spinelets on the disk longer, three times as long as thick or even longer, and much less numerous, about 30-35 to each square millimeter. The upper arm spines at the bases of the arms are more slender than those of *O. parva*, and less strongly flattened.

It differs from *O. caribbaea* in having the spinules on the disk longer, more sharply pointed, and more widely scattered.

*Locality*.—Galápagos Islands: Narborough Island; shore; W. L. Schmitt, July 25, 1938. One specimen (type, U.S.N.M. no. E.5638).

**OPHIONEREIS ROOSEVELTI, n. sp.**

Plate 2, figs. 7, 8

*Characters.*—The arms are black with well-separated small paired spots, and, distally, bands of white; the disk is brownish with numerous small whitish spots in the outer portion and fine parallel radiating whitish lines in the center; beneath, the arms are gray and the disk black; the arm spines are 4 on the first dozen arm combs beyond the edge of the disk, after which the uppermost is absent, so that there are only 3 from this point to the arm tip; the spines of the successive arm combs are aligned in regular rows along the arm.

*Description.*—In the larger of the two specimens, designated as the type, the disk is 19 mm. in diameter and the arms are 130 mm. long.

The entire aboral surface of the disk is covered with overlapping scales which are largest about the radial shields and in the radial areas, becoming much smaller in the center of the disk and in the interradial areas. Most of these scales are entirely concealed by a thick epidermis. Before the removal of the epidermis the only scales visible are the following: A row of about 15 conspicuous light-colored scales runs outward from the ends of the radial shields along the edge of the aboral surface of the disk for about one-third the distance across the interbrachial space. These scales, which imbricate toward the radial shields, become small and irregular toward the outer end of the row. In the angle between this row of scales and the radial shields, and extending downward for some distance behind the radial shields, there is a more or less obscured group of scales, with an indefinite border.

At the base of the arms, beyond the disk, the arm spines are 4 in number. All 4 spines are approximately of the same length. The 2 central spines are stout, slightly flattened, with abruptly truncated, broadly rounded ends, the lower spine of each pair slightly curved aborally. The uppermost spine is slightly more slender than the one just below it, and more strongly flattened. The lowest spine is markedly more slender and more tapering than the others. After the ninth to twelfth arm comb beyond the edge of the disk (usually the tenth or eleventh) the uppermost spine disappears, the combs from that point onward to the tip of the arm consisting of 3 spines of approximately the same length, of which the 2 uppermost are similar, stout and blunt, and the lowest is more slender and more tapering. In the outer portion of the arms the difference between the spines gradually disappears so that in the terminal portion the combs are composed of 3 similar rather slender tapering spines. The spines on successive combs are all at the same height so that the spines are aligned in regular rows along the arm, first in 4 rows, later in 3.

The disk is brownish, becoming dark in the center and in the inter-radial areas, with numerous small whitish spots, and in the central portion fine parallel radiating whitish lines. The arms above are slaty black with pairs of white spots, each the length of an upper arm plate in diameter, spaced somewhat unequally at intervals of 4-7 upper arm plates; in the outer half of the arms these spots fuse to form narrow bands which in width are equal to from 1 to 2 upper arm plates. The arm spines in the basal portion of the arms are tipped with white. Beneath, the arms are dark gray and the interradial areas black.

*Note*.—Another specimen from the same locality has the disk 11 mm. in diameter and the arms 75 mm. long.

*Locality*.—Galápagos Islands: Elizabeth Bay, Albemarle Island; south end of the black beach north of the mangroves north of the two "red" islands. Two specimens (cotypes, U.S.N.M. no. E.5618).

*Note*.—It gives me great pleasure to name this species for President Franklin D. Roosevelt, in grateful appreciation of his kindness and generosity in obtaining for the United States National Museum this unusually interesting collection of echinoderms.

*Remarks*.—Lütken and Mortensen (Mem. Mus. Comp. Zoöl., vol. 23, No. 2, p. 162, pl. 13, fig. 12, 1899) recorded and figured a single arm of a large species of *Ophionereis* from the Galápagos Islands (*Albatross* station 3405, 53 fathoms) with very broad upper arm plates and very small supplementary plates. These features appear to indicate, according to them, that the species represented by the arm is undescribed. Their figure shows that it cannot be referred to *O. roosevelti*; the upper arm plates are much broader and the supplementary plates are much smaller; the color, also, is wholly different.

#### OPHIODERMA APPRESSA (Say)

*Locality*.—Old Providence Island, 120 miles east of the Mosquito Coast (lat. 13°21' N., long. 81°22' W.); shore; reef and tide-pool collecting; August 1, 1938. Three specimens (U.S.N.M. no. E5607).

#### ASTEROIDEA

##### ECHINASTER PARVISPINUS A. H. Clark

*Locality*.—Lower California: Magdalena Bay, inside the northern point of the entrance to bay, between Belcher Point and the anchorage; 10-15 fathoms (18-27 m.); sandy and weedy bottom; July 18, 1938. Three specimens (U.S.N.M. no. E.5610).

*Note*.—In these three specimens  $r = 33$  mm.

**HELIASTER CUMINGII (Gray)**

Plate 3, fig. 9

*Locality*.—Galápagos Islands: Elizabeth Bay, Albemarle Island; south end of the black beach north of the mangroves north of the two "red" islands. July 26, 1938. One specimen (U.S.N.M. no. E.5611).

*Notes*.—In this specimen there are 21 arms;  $R = 30$  mm.,  $r = 16$  mm. The spines on the abactinal surface are rather widely scattered and are strongly capitate. They are single except in the midline of the free portion of each ray where there are five groups, the innermost of 2 spines and the distal three of usually 3, sometimes 2, rarely 4.

The rays are of various lengths, showing that the animal is undergoing active ray reduplication. In addition to the perfectly formed arms of various sizes, there are 4 arm buds all situated in interradial openings having the appearance of rents in the aboral epidermal covering, the inner edge of which in all cases is 10 mm. from the center of the disk, or 6 mm. within the bases of the free rays.

These arm buds arise far below the aboral epidermal covering, apparently between the upper portions of the proximal marginal plates of 2 adjacent rays, and grow upward. The tip is provided with a terminal row of 4 and a subterminal row of 5 short stout spines armed with stout low conical spinelets. The furrow spines are well developed. When the growing arm bud reaches the epidermal covering the latter is ruptured, and the edge of the rent draws away from the arm bud leaving a conspicuous opening.

The arm bud now grows outward and slightly downward, parallel with the aboral surfaces of the adjacent rays, the tip, however, remaining turned up at right angles to the rapidly extending newer growth which, becoming deeper and developing a dark epidermal covering with the usual capitate spines, rapidly repairs the inner portion of the rent, at the same time extending it toward the interbrachial border; on reaching the interbrachial border the arm bud grows outward into an arm of the typical form.

The tube feet in the arm buds, as in the fully developed arms, are in 2 rows which are slightly zigzag, alternate tube feet being nearer and farther from the midline of the groove.

The largest of the arm buds, which reaches to within 4 mm. of the interbrachial angle, beyond the end of which the rent extends entirely through the animal from the aboral to the oral side, is visible on the oral surface, were it separates 2 of the arms for about half the distance from their bases to the interbrachial angle. It appears as a small

replica of the bases of the adjacent arms, with small furrow spines and small tube feet, set considerably below the general surface.

The arm buds are situated as follows, clockwise from the madreporite; the 2 larger in interradial 2 and 14, the 2 very small ones in interradial 11 and 19.

#### SCLERASTERIAS, sp.

*Locality*.—Galápagos Islands: Tagus Cove, Albemarle Island; from the anchor chain in 50 fathoms (91 m.) of water; July 26, 1938. One specimen (U.S.N.M. no. E.5643).

*Notes*.—The specimen at hand is small and young;  $R=8.5$  mm.,  $r = 2$  mm.; there are 6 arms, 5 of full size and the sixth in the form of a well developed bud; there are 12-13 inferomarginal and 43 adambulacral plates.

Prof. Walter K. Fisher was so very kind as to examine this specimen for me.

#### ECHINOIDEA

##### EUCIDARIS THOUARSII (Agassiz and Desor)

*Localities*.—Galápagos Islands: Sullivan Bay, James Island; July 24, 1938. Two specimens (U.S.N.M. nos. E.5632, E.5633).

Galápagos Islands: Elizabeth Bay, Albemarle Island; July 26, 1938. One specimen (U.S.N.M. no. E.5634).

Galápagos Islands: Post Office Bay, Charles Island; July 27, 1938. Seven specimens (U.S.N.M. no. E.5637).

*Notes*.—One of the specimens from James Island (E.5632) is the largest recorded for this species. The horizontal diameter is 76 mm., the height is 57 mm., and the longest spines are 68 mm. long.

##### HESPEROCIDARIS HOUSTONIANA, n. sp.

Plate 4, figs. 10, 11; plate 5, figs. 12-14

*Characters*.—The interporiferous zone of the ambulacra is elevated and is completely covered by the 2 marginal rows of large and the 2 inner rows of small tubercles; the primary spines are about one-third again as long as the horizontal diameter of the test and are slightly tapering, slightly flattened, abruptly truncated distally, and carry 13 or 14 rows of granules which are low and evenly rounded on the oral side, but rise into conical prominences on the aboral side. The new species is most closely related to *H. panamensis* (A. Agassiz) from which, however, it appears to be quite distinct.



*Description.*—The test is 17 mm. in horizontal diameter, and 8 mm. in height; the apical system and the peristome are both 8 mm. in diameter; the primary spines are 22 mm. long.

The test is circular, much flattened, twice as broad as high, with strongly curved sides; the apical system is flat; about the peristome the border of the test is slightly incurved; the apical system and the peristome are of the same size, their diameter being one-half that of the test.

The ambulacra at the ambitus are 2.5 mm. broad, and the interambulacra are 8 mm. broad, the width of the ambulacra being 31 percent of that of the interambulacra. Above the ambitus the ambulacra are slightly sinuate.

The interporiferous zone of the ambulacra is elevated slightly above the surface of the poriferous zones on either side, which slope upward toward it. At the ambitus the interporiferous zone is 1.2 mm. in width and the adjacent poriferous zones are 0.6 mm., the interporiferous zone being about twice the width of the adjacent poriferous zones.

In the interporiferous zone the marginal series of tubercles are very regular. The tubercles in these series are large, their diameter being markedly greater than that of the adjacent pores, and they are separated from each other by about their own diameter. Between the 2 rows of marginal tubercles are 2 rows of smaller tubercles. The tubercles in these 2 inner rows are about as large as a pore. They are situated in the lower angles of the plates, and their outer side is tangent to the midambulacral articular lines between the plates so that the interporiferous zone shows no naked median area. The tubercles of these 2 rows alternate with each other, and also with the large tubercles of the marginal rows.

In the interambulacra the areoles are low, and their edges are not raised. Those at the ambitus are slightly oval transversely, and those below become progressively more and more strongly oval. The areoles at the ambitus measure 3.6 by 3 mm. The 2 or 3 areoles nearest the peristome are confluent, the 2 uppermost are separated by 2 rows of tubercles, and the second and third from the apical system are separated by 2 rows of reduced tubercles, or are in some cases confluent; the areoles at the ambitus are separated from those above and below by usually a single row of tubercles. The boss is rather low with a small mamelon having a small perforation, which shows no trace of crenulation. The edge of the platform of the areoles below the ambitus is smooth; at the ambitus it bears from 20 to 25 tubercles, though the row may be more or less deficient. Around each

areole there is a row of scrobicular tubercles, interrupted below on the areoles at the ambitus, and both above and below on those below the ambitus. In the midline of the interambulacra below, but not above, the ambitus there is a somewhat irregular row of smaller tubercles between the scrobicular tubercles surrounding adjacent areoles so that the midline of the interambulacra is completely filled with tubercles.

The diameter of the apical system is one-half that of the test at the ambitus. The oculars are all rather widely exsert. The genital pores are small, and are situated about one-third of the distance from the outer apex to the inner edge of the genital plates. The genital plates are 2.8 mm. wide at the base and 2.4 mm. long in the midline. The oculars bear 7-9 tubercles, the genitals 14-18; each of the small plates in the periproctal area bears a single tubercle, some of the larger peripheral ones sometimes having 2 or even 3. As the tubercles on the genital and ocular plates are rather widely separated, the dense mass of secondary spines on the periproctal plates is separated from the row of closely placed spines along the outer borders of the oculars and genitals by a conspicuous, almost completely naked, band about 1.5 mm. wide.

The peristome is almost flat. There are 10-11 plates in each ambulacral series, and 4 in the interambulacral series.

The primary spines are about one-third again as long as the horizontal diameter of the test. They are fairly slender, slightly flattened, and taper gradually to an abruptly truncated, though not expanded, tip. The shaft is closely set with granules arranged in 13 or 14 longitudinal lines which just at the tip of the spine become ridges. The granules in each line alternate with those in the lines on either side. On the oral side of the spine these granules are low, elongated in the direction of the longitudinal axis of the spine, and have evenly convex and highly polished surfaces. On the aboral side the granules rise into cones directed distally, the apex of the cones being almost or quite above the distal edge of the base. The granules and cones are rather well separated from each other, and the space between them is occupied by a sort of loose spongy felting of rather coarse glassy anastomosing hairs. The neck of the spines is usually, though not always, distinct. It is from one-half to quite as long as the collar, shows only slight indications of the granules, and is highly polished, lacking the felted covering. The collar is somewhat more than 1 mm. in length, cylindrical, and very finely striate, the striations being narrow, high, and well separated, with a finely serrate crest. In occasional spines, somewhat more tapering than the others, the features of the collar

are continued to the tip; there is no felted covering, and the granules are indicated only by slight elevations over which the fine striations run uninterruptedly. The milled ring is low and not conspicuous; it is of the same color as the collar.

The topmost primary spine in each interambulacrum is rudimentary, consisting of a broadly truncated cone about as high as broad at the base with strongly convergent sides and the edges of the base broadly rounded. The surface is somewhat spongy, with very numerous and very fine striations. There are 5 of these rudimentary spines about the apical system.

The oral primaries are about 4.5 mm. long with a very long collar occupying about their proximal half, beyond which they are smooth and more or less polished. The second is transitional to the ambital spines.

The secondary spines are slender and flattened. The scrobicular spines are 3 mm. long, strongly flattened, broadly truncate or with the distal end more or less convex, and have parallel sides that in the proximal quarter converge to the base.

The marginal ambulacral spines are 2.5 mm. long, resembling the scrobicular spines but much narrower. The miliary spines are small, delicate, and sharply pointed.

The pedicellariae resemble those of related species. Small globiferous pedicellariae are numerous and conspicuous, large globiferous and tridentate rather uncommon.

The color is bright brownish red, the tips of the scrobicular and ambulacral marginal spines sometimes showing a purplish tinge. The primary spines are light at the base, becoming darker in the outer two-thirds, where they may be obscurely banded or blotched with lighter. When dry, the spongy covering gives them a frosted appearance between the granules. The collar is brownish red, somewhat lighter than the adjacent scrobicular spines, and the neck is of the same color. The oral primaries have whitish tips.

The test is dull creamy white, with the peristome and the interporiferous areas of the ambulacra tinged with dull yellowish. The apical system is pale brownish red, fading to whitish on the border of each plate. The plates surrounding the apical system are faintly tinged with greenish.

*Locality*.—Galápagos Islands: Tagus Cove, Albemarle Island; from the anchor chain in 50 fathoms (91 m.) of water; July 26, 1938. Six specimens (type, U.S.N.M. no. E.5604; the other five specimens under U.S.N.M. nos. E.5605 and E.5606).

*Comparisons.*—This new species is allied to *H. panamensis* from which it differs most noticeably in the characters of the interporiferous zone of the ambulacra, which is slightly elevated with larger tubercles than those seen in *H. panamensis* and no naked median line, and in the primary spines, which are tapering and have 13-14 longitudinal series of granules instead of being cylindrical with about 16-18 series of granules as in *H. panamensis*.

My friend Dr. Hubert Lyman Clark, of the Museum of Comparative Zoölogy at Harvard, to whom I submitted two specimens for comparison with *H. panamensis*, writes that he regards these as young specimens of *panamensis*, although he notes that there is some diversity in the slenderness and form of the primary spines. He does not mention the differences in the interporiferous zone of the ambulacra.

#### LYTECHINUS SEMITUBERCULATUS (L. Agassiz and Desor)

*Localities.*—Galápagos Islands: Elizabeth Bay, Albemarle Island; south end of the black beach north of the mangroves north of the two "red" islands; July 26, 1938. Two specimens (U.S.N.M. no. E.5617).

Galápagos Islands: South Seymour Island; north end of the plateau land section of the island; July 29, 1938. Five dead tests (U.S.N.M. no. E.5616).

*Note.*—The larger of the two specimens from Albemarle Island has a horizontal diameter of 28 mm.

#### CAENOCENTROTUS GIBBOSUS (L. Agassiz and Desor)

*Locality.*—Galápagos Islands: Elizabeth Bay, Albemarle Island; south end of the black beach north of the mangroves north of the two "red" islands; July 26, 1938. Two specimens (U.S.N.M. nos. E.5608, E.5609).

*Notes.*—One of the specimens is 45 mm. in horizontal diameter and olive green in color. The other is 20 mm. in diameter; the test is bright green with the poriferous areas abactinally light buff; the spines are dark brown becoming olive toward the base.

#### ECHINOMETRA LUCUNTER (Linné)

*Locality.*—Old Providence Island, 120 miles east of the Mosquito Coast (lat. 13°21' N., long. 81°22' W.); shore; reef and tide-pool collecting; August 1, 1938. Four specimens (U.S.N.M. nos. E.5622, E.5636).

*Note.*—The largest of the four specimens measures 52 by 43 mm.

**ECHINOMETRA INSULARIS H. L. Clark**

*Locality*.—Galápagos Islands: Post Office Bay, Charles Island; July 27, 1938. One specimen (U.S.N.M. no. E.5621).

*Notes*.—This specimen measures 44 by 39 mm.; the longest primary spines are 35 mm. long. There are 6 pore pairs above the ambitus and 5 below. The test is white, more or less tinged with purple aborally; the spines vary from deep purple to black.

**ENCOPE PERSPECTIVA L. Agassiz**

*Locality*.—Lower California: off Punta Gorda, Cape San Lucas; off rocky shore to west, and San Jose del Cabo Bay; 6-10 fathoms (11-18 m.); July 19, 1938. One specimen (U.S.N.M. no. E.5635).

*Note*.—The specimen is 95 mm. long.

**ENCOPE MICROPORA L. Agassiz**

*Locality*.—Lower California: off Punta Gorda, Cape San Lucas; off rocky shore to west, and San Jose del Cabo Bay; 6-10 fathoms (11-18 m.); July 19, 1938. Sixteen specimens (U.S.N.M. no. E.5620).

*Note*.—The specimens vary from 10 to 66 mm. in length.

## EXPLANATION OF PLATES

## PLATE I

- FIG. 1. *Ophiocomella parva*, a 7-armed specimen from Clipperton Island, aboral view (U.S.N.M. no. E.5639).  $\times 3$ .
- FIG. 2. *Ophiocomella parva*, another 7-armed specimen from Clipperton Island, oral view (U.S.N.M. no. E.5639).  $\times 3$ .
- FIG. 3. *Ophiocomella schmitti*, n. sp., the type specimen from Narborough Island, Galápagos, aboral view (U.S.N.M. no. E.5638).  $\times 3$ .
- FIG. 4. *Ophiocomella schmitti*, n. sp., the type specimen from Narborough Island, Galápagos, oral view (U.S.N.M. no. E.5638).  $\times 3$ .
- FIGS. 5, 6. *Ophiothrix galapagensis*, two specimens from James Island, Galápagos, aboral view, showing variation in the spinulation of the disk (U.S.N.M. nos. E.5613 [fig. 6] and E.5614 [fig. 5]).  $\times 2$ .

## PLATE 2

- FIG. 7. *Ophionercis roosevelti*, n. sp., the cotypes from Albemarle Island, Galápagos, aboral view (U.S.N.M. no. E.5618).  $\times 2$ .
- FIG. 8. *Ophionercis roosevelti*, n. sp., the cotypes from Albemarle Island, Galápagos, oral view (U.S.N.M. no. E.5618).  $\times 2$ .

## PLATE 3

- FIG. 9. *Heliaster cuningii*, a young individual from Albemarle Island, Galápagos; the pointers indicate the four arm buds (U.S.N.M. no. E.5611).  $\times 3$ .

## PLATE 4.

- FIG. 10. *Hesperocidaris houstoniana*, n. sp., from Albemarle Island, Galápagos, oral view (U.S.N.M. no. E.5605).  $\times 2$ .
- FIG. 11. *Hesperocidaris houstoniana*, n. sp., from Albemarle Island, Galápagos, aboral view (U.S.N.M. no. E.5605).  $\times 2$ .

## PLATE 5

- FIG. 12. *Hesperocidaris houstoniana*, n. sp., the type specimen from Albemarle Island, Galápagos, aboral view (U.S.N.M. no. E.5604).  $\times 2$ .
- FIG. 13. *Hesperocidaris houstoniana*, n. sp., the type specimen from Albemarle Island, Galápagos, lateral view (U.S.N.M. no. E.5604).  $\times 2$ .
- FIG. 14. *Hesperocidaris houstoniana*, n. sp., the type specimen from Albemarle Island, Galápagos, oral view (U.S.N.M. no. E.5604).  $\times 2$ .

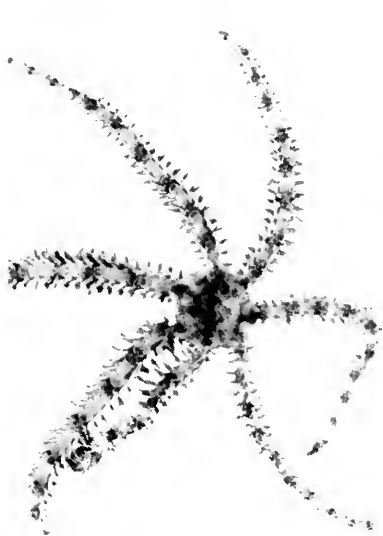

1

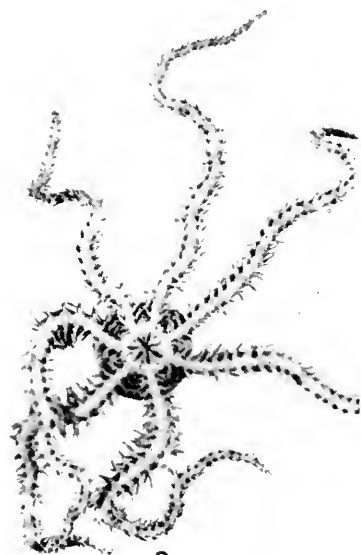

2



3



4



5

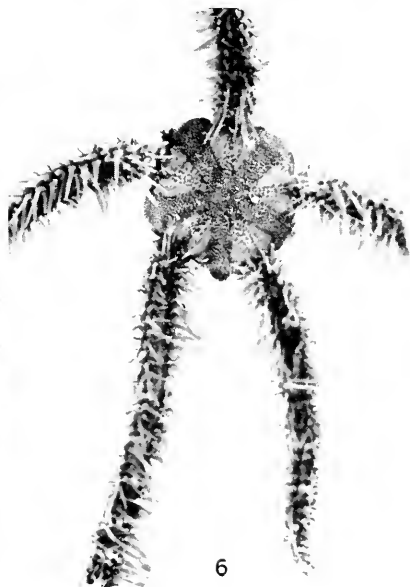

6

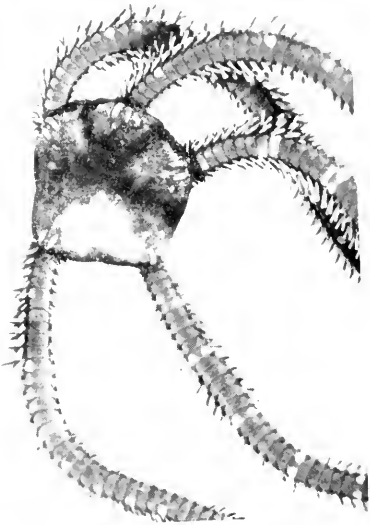
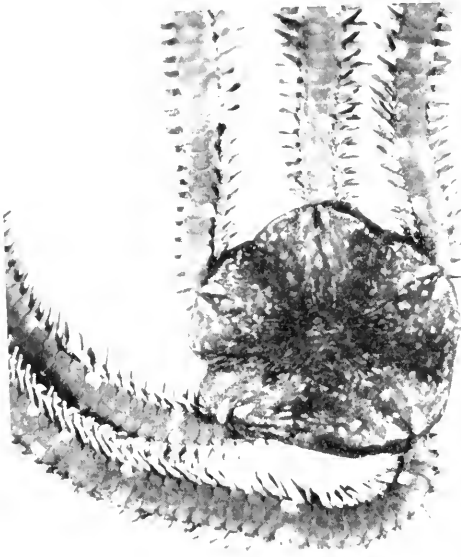

7



8

*OPHIONEREIS ROOSEVELTI*, N. SP.

(For explanation, see p. 17.)



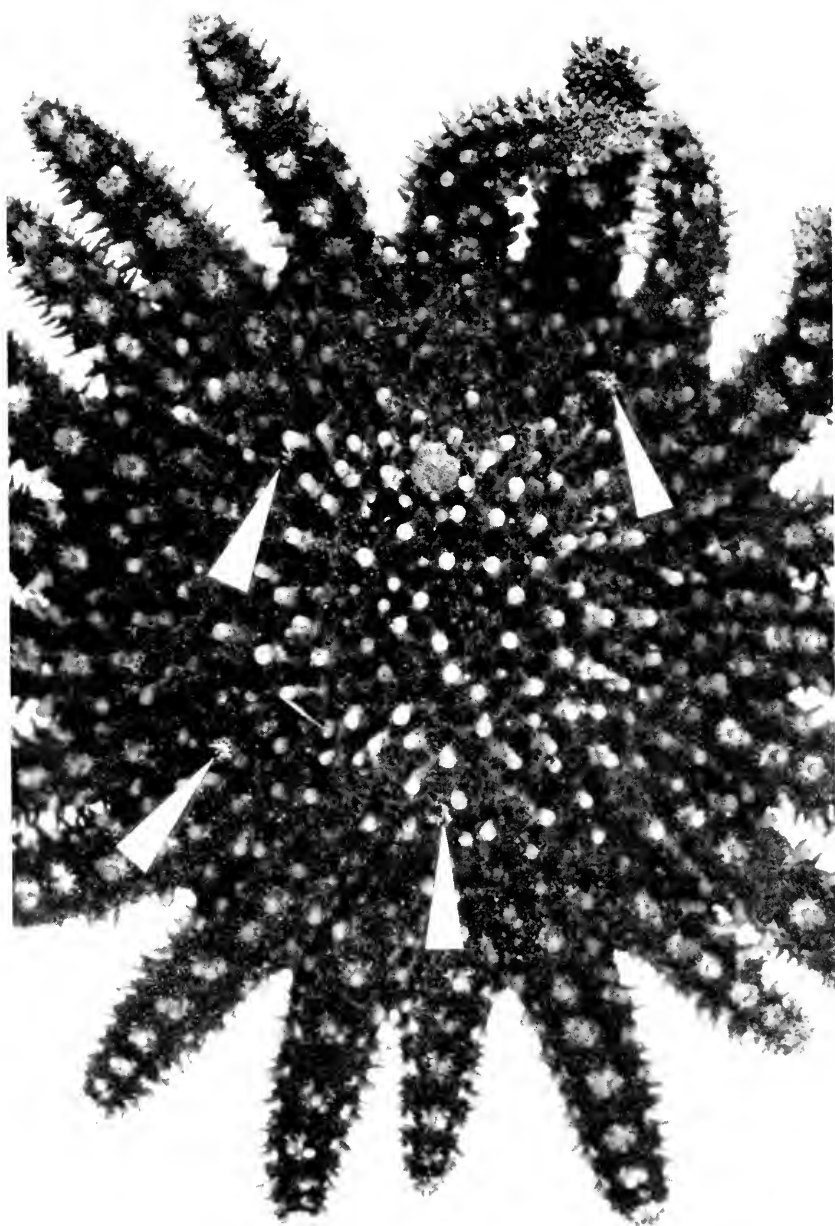

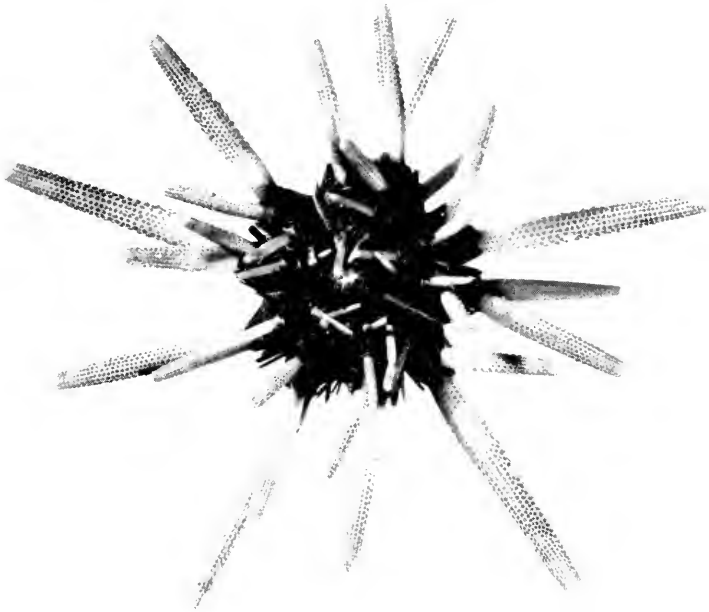

10



11

*HESPEROCIDARIS HOUSTONIANA*, N. SP.  
(For explanation, see p. 18.)



12

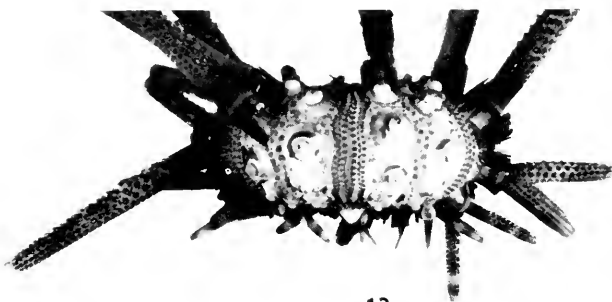

13



14

*HESPEROCIDARIS HOUSTONIANA*, N. SP.

(For explanation, see p. 18.)



SMITHSONIAN MISCELLANEOUS COLLECTIONS

VOLUME 98, NUMBER 12

A NEW HOLOTHURIAN OF THE GENUS THYONE  
COLLECTED ON THE PRESIDENTIAL  
CRUISE OF 1938

BY

ELISABETH DEICHMANN

Museum of Comparative Zoölogy,  
Harvard University

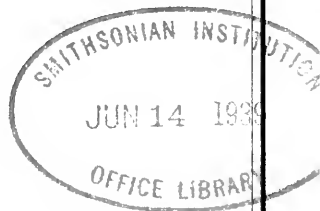

(PUBLICATION 3537)

CITY OF WASHINGTON  
PUBLISHED BY THE SMITHSONIAN INSTITUTION  
JUNE 14, 1939



SMITHSONIAN MISCELLANEOUS COLLECTIONS

VOLUME 98, NUMBER 12

A NEW HOLOTHURIAN OF THE GENUS THYONE  
COLLECTED ON THE PRESIDENTIAL  
CRUISE OF 1938

BY

ELISABETH DEICHMANN

Museum of Comparative Zoölogy,  
Harvard University



(PUBLICATION 3537)

CITY OF WASHINGTON  
PUBLISHED BY THE SMITHSONIAN INSTITUTION  
JUNE 14, 1939

The Lord Baltimore Press  
BALTIMORE, MD., U. S. A.



A NEW HOLOTHURIAN OF THE GENUS THYONE  
COLLECTED ON THE PRESIDENTIAL  
CRUISE OF 1938

BY ELISABETH DEICHMANN

*Museum of Comparative Zoölogy, Harvard University*

Among the echinoderms collected by Dr. Waldo L. Schmitt during the Presidential cruise on the U.S.S. *Houston* in the summer of 1938 there are only two sea-cucumbers, both belonging to the same species. These two individuals were collected in Magdalena Bay on the west coast of Lower California. They represent a new species, which, however, is closely related to a form known from tide pools in California but, so far as our present knowledge goes, not known from south of Morro Beach.

Magdalena Bay seems to be the northern limit for the tropical "Panamic" region on the western coast of Lower California, and it is therefore likely that the new species will be found in other localities within the "Panamic" region. On the eastern side of Lower California the "Panamic" region reaches northward to the mouth of the Rio Colorado.

**THYONE LUGUBRIS, n. sp.**

*Diagnosis.*—A small form, a few centimeters long, with stout feet which are slightly larger and more numerous on the ventral side, where the original arrangement in 3 bands often is visible; on the dorsal side some of the feet are more papilliform. Tentacles 10, the 2 ventral smaller than the others. Calcareous ring with distinct, though fairly short, posterior prolongations on the radials; both the radials and interradials have a long anterior tooth. Stone canal small, delicate, embedded in the dorsal mesentery; head small, flattened with thickened edges, free to the right. Polian vesicle single, ventrally placed.

Spicules consisting of an external layer of knobbed buttons or plates with the external side covered by a reticulum. The inner layer consists of regular 4-holed knobbed buttons; the central knobs are often united into a distinct handle; some buttons are more lozenge-shaped, with an accessory hole in each end. In very small individuals

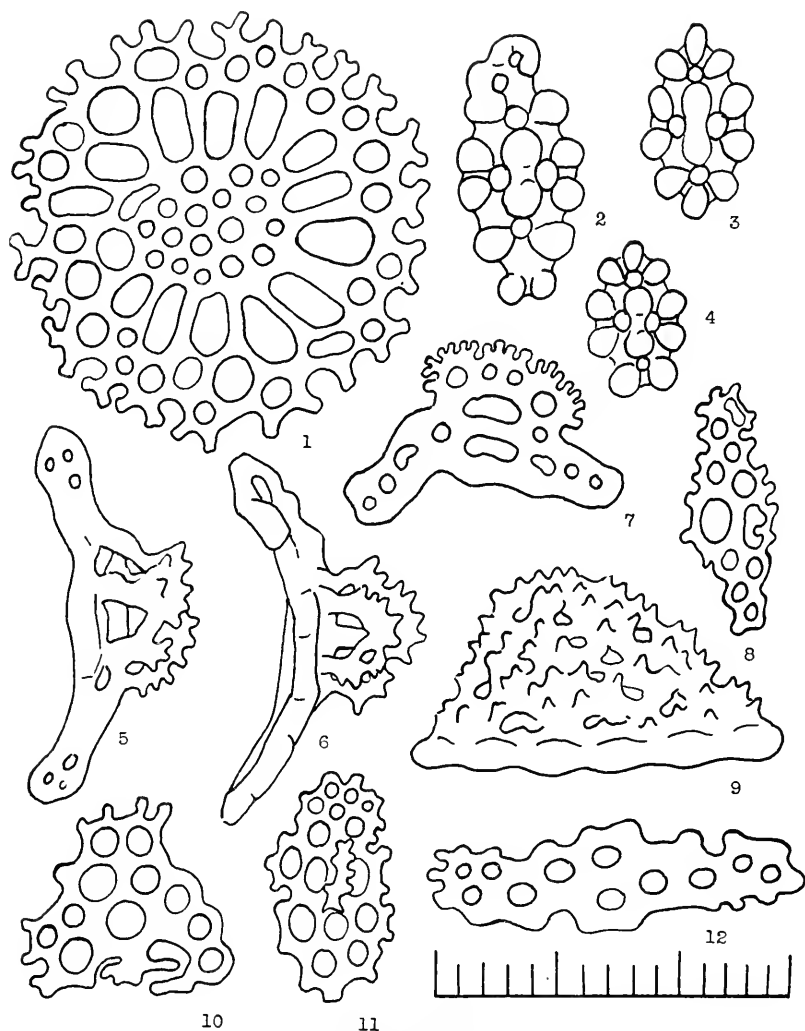

FIG. 1.—*Thyone lugubris*, n. sp.

1, end plate from young individual 3 mm. long; 2-4, knobbed buttons from inner layer of integument; 5-7, supporting tables from tube feet; 8, 10, 12, plates from tentacles; 9, plate from superficial layer of integument with external side covered by a reticulum; 11, table from introvert.

All from type, except No. 1 which is from an embryo from the type.

Scale,  $\frac{1}{100}$  mm.

(3 mm. long) this inner layer is not yet developed. Feet with large end plate, which is reduced in the papilliform feet on the dorsum; the walls are filled with numerous supporting tables with a reticulated spire composed of numerous rods and ending in numerous branches or teeth. The introvert contains tables with a low spire and numerous holes in the disk. The tentacles are packed with heavy perforated rods and plates; toward the terminal branches the deposits become smaller and more delicate, with larger holes.

The color is mottled brownish, with black tentacles.

The species is viviparous.

*Locality.*—Magdalena Bay, west coast of Lower California; inside the northern point of the entrance to the bay, between Belcher Point and the anchorage; 10-15 fathoms (18-27 m.); sandy and weedy bottom; July 18, 1938. Two specimens. (Type, U.S.N.M. no. E.5624; cotype, U.S.N.M. no. E.5625.)

*Remarks.*—The type is a female 15 mm. in length, with 13 embryos, and the cotype is probably a male, 10 mm. long; both are well expanded.

The gonads are well developed in both specimens and consist of 2 tufts each with about 10 tubules. In the larger type the tubules are short and some are almost empty—one contains one large egg while the others are more opaque. The oviduct appears to open into the body cavity, near the stone canal. Thirteen embryos of varying age were found lying free in the body cavity. The smallest embryo measures 1 mm. in length and lacks all appendages except 5 cylindrical tentacles. The largest embryo measures 3 mm. and has 5 double rows of tube feet and the full number of tentacles, which all are branching as in a typical dendrochirote. The spicules in the smallest embryo are of the usual juvenile type which occurs in almost all immature specimens—large plates regularly perforated by holes all of about the same size. In the stages following, the typical spicules begin to appear, although rather incompletely developed. In the oldest stages the spicules are as in the mother animal, except that the layer of inner buttons has not yet appeared. The color of the embryos ranges from completely unpigmented white to mottled gray with numerous pigment dots.

The cotype has gonads with much longer tubules, with scattered pigment spots. The tubules are opaque and appear to contain only small cells, so it is probably a male. The opening of the gonadial duct could not be traced with certainty; probably it opens on the dorsal side between the tentacles or closely behind them as in most *Dendrochirota*.

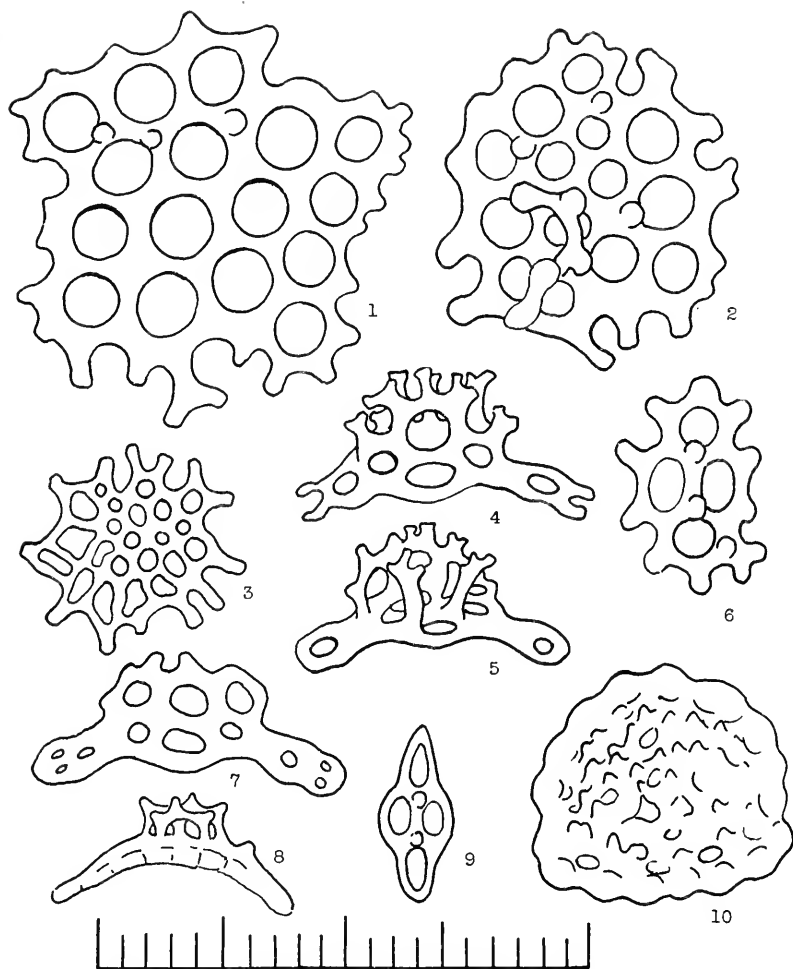

FIG. 2.—*Thyone lugubris*, n. sp.

1-2, primitive plates from integument of small embryo; 3, end plate from a small embryo, with few tube feet; 4-5, 7-8, supporting tables from tube feet; 6, beginning stage of knobbed reticulated plate from external layer of integument; 9, beginning stage of a knobbed button; 10, knobbed reticulated plate from external layer of integument.

All from a small embryo, 1.5 mm. long.

Scale,  $\frac{1}{100}$  mm.

From the Californian form *Thyone rubra* H. L. Clark, *Thyone lugubris* differs in its mottled grayish brown color and black tentacles, contrasting strikingly with the vivid orange dorsum and tentacles and snow-white ventrum of the northern form. The former reaches normally a length of 30-40 mm., but very likely this is also true of *lugubris*, as apparently most dendrochirotes continue their growth after reproduction has set in. The spicules are slightly smaller in the southern than in the northern form.

Both species are viviparous, and the observations made by Dr. H. L. Clark regarding the number of embryos developed, etc., in *Thyone rubra* agree in all essentials with what has been found in *Thyone lugubris*.

The life history of the dendrochirote holothurians in which the female develops the embryos free in the body cavity is rather imperfectly known. Hörstadius (1926) has studied the very similar conditions in the Mediterranean form *Phyllophorus urna* Grube, and was the first to discover that the oviduct opened directly into the body cavity, as one logically would expect, and apparently the eggs are set free here at intervals. How they are fertilized—if, indeed, they are fertilized at all—is unknown. When the embryos have reached a length of several millimeters, they are apparently set free one or two at a time, probably by breaking through the respiratory trees or through the intestine.

Both *Thyone rubra* and *Th. lugubris* belong definitely to the same group, and when the genus *Thyone* finally is revised they will be placed in a separate genus by themselves. They differ from the two other species of *Thyone* with knobbed buttons which are known from the tropical part of the Pacific coast of America in the presence of the large buttons or plates with the external side covered by a huge reticulum. The other species have either buttons with a strongly spinous handle (*Thyone gibber* [Selenka]), or an external layer of delicate reticulated baskets (*Thyone panamensis* Ludwig).

From the West Indies no species so far has been reported which has spicules similar to those which characterize *lugubris* and *rubra*, nor does it appear, from a perusal of the literature, that they have any relatives in other parts of the Pacific Ocean.

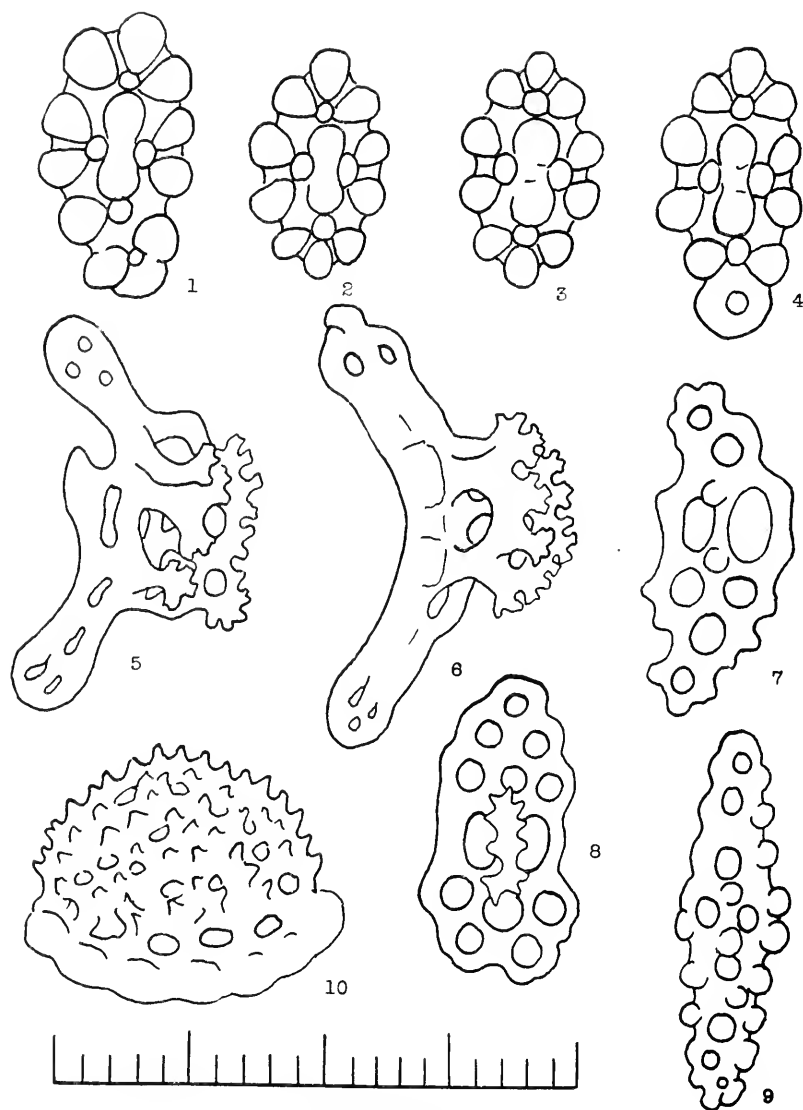

FIG. 3.—*Thyone rubra* H. L. Clark.

1-4, knobbed buttons from the inner layer of the integument; 5-6, supporting tables tube feet; 7-8, tables from introvert; 9, plate from tentacle; 10, knobbed plate from external layer of integument, medium size.

Scale,  $\frac{1}{100}$  mm.

## REFERENCES

CLARK, H. L.

1901. The holothurians of the Pacific coast of North America. *Zool. Anz.*, vol. 24, pp. 162-171, text figs. 1-14.

DEICHMANN, E.

1930. The holothurians of the western part of the Atlantic Ocean. *Bull. Mus. Comp. Zool.*, vol. 71, no. 3, pp. 41-226, pls. 1-24.
1936. A new species of *Thyone* from the west coast of Mexico. *Proc. New England Zool. Club*, vol. 15, pp. 63-66, text fig.

HÖRSTADIUS, S.

1926. Embryologische Beobachtungen über *Luidia ciliaris* Phil., *L. sarsi* Düben & Koren und *Phyllophorus urna* Grube. *Arkiv Zool.*, Stockholm, vol. 18 B, no. 8, pp. 1-5.





SMITHSONIAN MISCELLANEOUS COLLECTIONS  
VOLUME 98, NUMBER 13

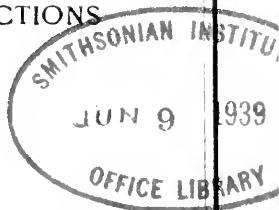

# THE POLYCHAETOUS ANNELIDS COLLECTED ON THE PRESIDENTIAL CRUISE OF 1938

BY  
OLGA HARTMAN  
The Allan Hancock Foundation  
University of Southern California



(PUBLICATION 3538)

CITY OF WASHINGTON  
PUBLISHED BY THE SMITHSONIAN INSTITUTION  
JUNE 9, 1939



SMITHSONIAN MISCELLANEOUS COLLECTIONS  
VOLUME 98, NUMBER 13

THE POLYCHAETOUS ANNELIDS  
COLLECTED ON THE PRESIDENTIAL  
CRUISE OF 1938

BY  
OLGA HARTMAN  
The Allan Hancock Foundation  
University of Southern California



(PUBLICATION 3538)

CITY OF WASHINGTON  
PUBLISHED BY THE SMITHSONIAN INSTITUTION  
JUNE 9, 1939

The Lord Baltimore Press  
BALTIMORE, MD., U. S. A.

THE POLYCHAETOUS ANNELIDS COLLECTED ON  
THE PRESIDENTIAL CRUISE  
OF 1938

By OLGA HARTMAN

*The Allan Hancock Foundation, University of Southern California*

These collections were made from July 18 to August 6, 1938. Localities include western Mexico, Clipperton Island, Galápagos Islands, Cocos Island, all in the eastern Pacific, and Old Providence Island, in the Caribbean Sea. Depths range from intertidal to 15 fathoms.

Though small, the collection is represented by 17 families, with 31 species, of which 2, *Ncanthos roosevelti* and *Polydora tricuspis*, are new to science, 1, *Cirratulus niger*, is newly named, and 2 others, *Scalictosus* sp., and *Armandia* sp., may represent undescribed species. Several others have had their range extended considerably into tropical waters.

Following is a list of stations, with species encountered:

Station No. 3-38. July 18. Magdalena Bay, inside northern point of entrance to bay, between Belcher Point and anchorage, dredged in 10-15 fathoms; sandy, weedy bottom.

	No. of specimens
<i>Halosydna fuscomarmorata</i> (Grube).....	6
<i>Palcanotus chrysolepis</i> Schmarda.....	1
<i>Uncinereis agassizi</i> (Ehlers).....	about 50
<i>Nereis callaona</i> Grube.....	2
<i>Eunice aedificatrix</i> Monro.....	1
<i>Polyopthalmus pictus</i> (Dujardin).....	about 100
<i>Armandia</i> , sp. ....	1
<i>Metachone mollis</i> Bush.....	5

Station No. 4-38. July 18. Magdalena Bay, Lower California; filamentous green algae from deeper end of preceding dredge haul.

	No. of specimens
<i>Uncinereis agassizi</i> (Ehlers).....	10

Station No. 5-38. July 19. Cape San Lucas, Lower California. Off Punta Gorda, off rocky shore to west and San Jose del Cabo Bay; dredged in 6-10 fathoms.

	No. of specimens
<i>Halosydna fuscomarmorata</i> (Grube).....	1
<i>Eusigalion spinosum</i> Hartman (in press).....	1
<i>Uncinereis agassizi</i> (Ehlers).....	3
<i>Eunice aedificatrix</i> Monro.....	1
<i>Polyphthalmus pictus</i> (Dujardin).....	4
<i>Metachone</i> sp., fragment.....	1

Station No. 8-38. July 20. Socorro Island, Mexico. On sandy bottom, from off landing beach toward rocky point forming east side of cove where landing place is located; dredged in 7-8 fathoms.

	No. of specimens
<i>Eunice biannulata</i> Moore.....	1
<i>Cirratulus niger</i> , new name.....	3

Station No. 9-38. July 21. Clipperton Island. Shore collecting on rocks to south of landing place.

	No. of specimens
<i>Eurythoe complanata</i> (Pallas).....	7
<i>Anaitides lamellifera</i> (Pallas).....	1
<i>Eunice</i> ( <i>Palolo</i> ) <i>siciliensis</i> Grube.....	2
<i>Mesochaetopterus minutus</i> Potts.....	numerous tubes
<i>Idanthyrsus pennatus</i> (Peters).....	1

Station No. 15-38. July 24. Sullivan Bay, James Island, Galápagos. Shore and tide-pool collecting.

	No. of specimens
<i>Scalisetosus</i> , sp. ....	1
<i>Syllis fuscotaturata</i> Augener.....	4
<i>Syllis hyalina</i> Grube.....	2
<i>Neanthes roosevelti</i> , new species.....	2
<i>Polydora tricuspis</i> , new species.....	1
<i>Idanthyrsus pennatus</i> (Peters).....	dried tubes

Station No. 16-38. July 25. Narborough Island, Galápagos. Shore collecting.

	No. of specimens
? <i>Syllis fuscotaturata</i> Augener.....	1

Station No. 19-38. July 26. Elizabeth Bay, Albemarle Island, Galápagos. Bay at south end of black beach north of mangrove, north of two "red" Islands.

	No. of specimens
<i>Nicolea galapagensis</i> Chamberlin.....	1

Station No. 20-38. July 26. Locality as for No. 19-38. Taken off anchor chain.

	No. of specimens
<i>Peisidice aspera</i> Johnson.....	1

Station No. 28-38. August 3. Chatham Bay, Cocos Island. Bottom sample, mostly sand.

	No. of specimens
<i>Chloëia entypha</i> Chamberlin.....	1

Station No. 30-38. August 6. Old Providence Island, Caribbean Sea. Shore, reef, and tide-pool collecting.

	No. of specimens
<i>Hermenia verruculosa</i> Grube.....	1
<i>Harmothoë lanceocirrata</i> Treadwell.....	1
<i>Eurythoë complanata</i> (Pallas).....	5
<i>Hermodice carunculata</i> (Pallas).....	3
<i>Hesionë intertexta</i> Grube.....	1
<i>Eunice schemacephala</i> Schmarda.....	2
<i>Polynnia nebulosa</i> (Montagu).....	3
<i>Sabellastarte indica</i> (Savigny).....	1

The collection includes representatives of 17 families, with species distributed as follows:

POLYNOIDAE

- Halosydna juscomarmorata* (Grube)
- Hermenia verruculosa* Grube
- Scaliscetus*, sp.
- Harmothoë lanceocirrata* Treadwell

POLYDONTIDAE

- Peisidice aspera* Johnson

SIGALIONIDAE

- Eusigalion spinosum* Hartman

CHRYSOPETALIDAE

- Paleanotus chrysolepis* Schmarda

AMPHINOMIDAE

- Eurythoë complanata* (Pallas)
- Hermodice carunculata* (Pallas)
- Chloëia entypha* Chamberlin

PHYLLODOCIDAE

- Anaitides lamellifera* (Pallas)

HESIONIDAE

- Hesionë intertexta* Grube

SYLLIDAE

- Syllis hyalina* Grube
- Syllis fuscocuturata* Augener

## NEREIDAE

*Uncinereis agassizi* (Ehlers)  
 ? *Nereis callaona* Grube  
*Neanthes roosevelti*, n. sp.

## EUNICIDAE

*Eunice biannulata* Moore  
*Eunice aedificatrix* Monro  
*Eunice schemacephala* Schmarda  
*Eunice (Palolo) siciliensis* Grube

## SPIONIDAE

*Polydora tricuspis*, n. sp.

## CHAETOPTERIDAE

*Mesochaetopterus minutus* Potts

## CIRRATULIDAE

*Cirratulus niger*, new name

## OPHELIIDAE

*Polyophthalmus pictus* (Dujardin)  
*Armandia*, sp.

## SABELLARIIDAE

*Idanthyrus pumatus* (Peters)

## TEREBELLIDAE

*Nicolca galapagensis* Chamberlin  
*Polynnia nebulosa* (Montagu)

## SABELLIDAE

*Sabellastarte indica* (Savigny)  
*Metachone mollis* Bush

## POLYNOIDAE

**HALOSYDNA FUSCOMARMORATA (Grube)**

*Polynoë fuscomarmorata* GRUBE, 1876, p. 62.

*Halosydna fuscomarmorata* MONRO, 1928, p. 566.

*Collection*.—Station Nos. 3-38, 5-38; 7 specimens.

Color dark gray. Ventrums with a broad dark neural stripe, and a longitudinal stripe on either side over the nephridial region. Elytra 18 pairs, with entire margin; neuropodial setae distally bifid. The nephridial papillae are subglobular.

*Distribution*.—Peru; Panama; Lower California.

**HERMENIA VERRUCULOSA Grube**

*Hermenia verruculosa* GRUBE, 1856, p. 44; MONRO, 1928, p. 40.

*Collection*.—Station No. 30-38; 1 specimen.

Length about 18 mm. Surface dorsally and ventrally closely covered with many tubercles. All elytra except first pair have been lost, the first are small, circular, not meeting in the middorsal line, their margins are entire, their surface tubercled. Dorsum is reddish brown, ventrum flesh-colored. The neuropodial setae are stout, with a main fang and a lateral tooth, but without lateral serrations.



**HARMOTHOË LANCEOCIRRATA** TreadwellFIGS. 1, *a-c**Harmothoë lanceocirrata* TREADWELL, 1928, p. 454.*Harmothoë lanccolata* TREADWELL, 1928, explanation of figures.*Collection*.—Station No. 30-38; 1 specimen.

The single individual is not quite complete posteriorly. It consists of 26 anterior segments, 16 mm. long; the last segment is the third-

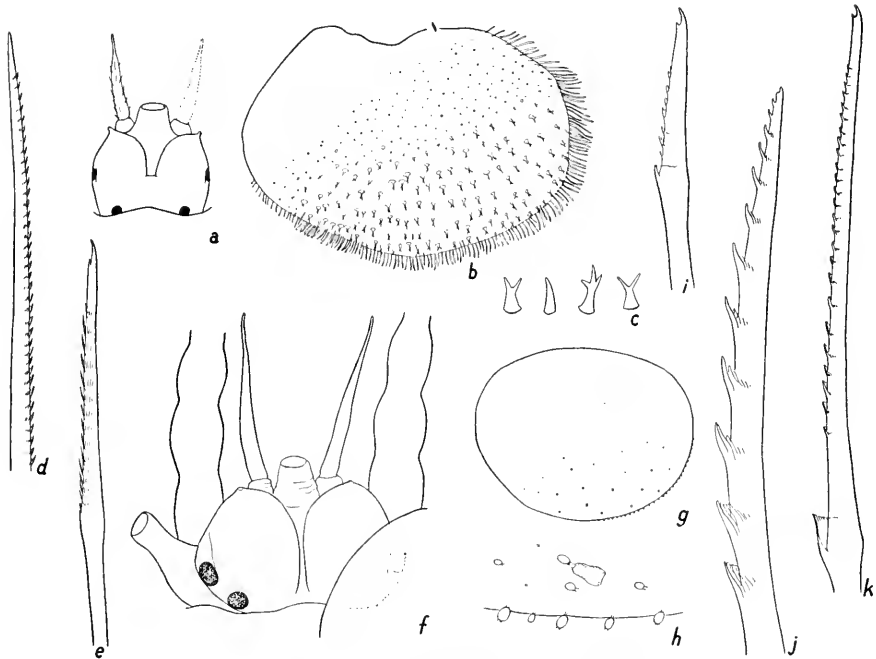
FIG. 1.—Species of *Harmothoë* and *Scalisetosus*.

*a-c, Harmothoë lanceocirrata*: *a*, prostomium, in dorsal view, the right antenna indicated in dotted outline,  $\times 40$ ; *b*, tenth elytrum, from right side,  $\times 15$ ; *c*, simple, bifid, and trifid spines from tenth elytrum,  $\times 40$ ; *d*, a long notopodial seta from a median parapodium,  $\times 78$ ; *e*, a neuropodial seta from middle part of fascicle, taken from a median parapodium,  $\times 78$ .

*f-k, Scalisetosus*, sp.: *f*, prostomium, bases of palpi, and part of right first elytrum,  $\times 40$ ; *g*, elytrum from near middle of body, the elytral scar indicated,  $\times 20$ ; *h*, portion of elytrum, with 5 marginal papillae and a larger surface spine with soft terminal knob,  $\times 175$ ; *i*, inferior neuropodial seta from a median parapodium,  $\times 175$ ; *j*, tip of a notopodial seta from a median parapodium,  $\times 175$ ; *k*, tip of a superior neuropodial seta from a median parapodium,  $\times 175$ .

teenth elytriphorous. Body colorless save for 4 black eyes; setae and acicula pale straw-colored. All cirri have been lost except the left prostomial antenna, this is hirsute, and has the proportions shown by Treadwell (1928, p. 454) for the right prostomial antenna. All elytra missing except the tenth from the right side; it is only slightly

excavate at its anterior margin, heavily and closely fringed at its post-lateral margins (fig. 1, *b*), and has many tall, slender tubercles, particularly crowded on its posterior two-thirds. These tubercles are either simple, spinelike, or have their distal ends terminating in 2 or 3 sharp cusps (fig. 1, *c*). Each spine arises from an elytral aerolation which is difficult to make out unless the elytrum is cleared, because of the abundance of the surface structures.

Notopodial and neuropodial setae are disposed in stout, full, spreading fascicles. The notopodial setae (fig. 1, *d*) are somewhat thicker than the neuropodial setae (fig. 1, *e*), and extend nearly as far laterally.

This specimen departs somewhat from the original description in the following: (1) The prostomium is broader than long, and has 4 black eyes (fig. 1, *a*); (2) the aerolation of the elytra is much less conspicuous, though obviously present; (3) the elytral fringe is heavier and longer, and (4) the elytral tubercles are simple, bifid, or trifid, though the bifid tubercles predominate. These differences are perhaps not sufficiently great to indicate specific variation.

*Distribution*.—Caribbean Sea (Treadwell); Old Providence Island, Caribbean Sea.

#### SCALISETOSUS, sp.

FIGS. 1, *f-k*

*Collection*.—Station No. 15-38; 1 specimen.

Length 15 mm., number of segments 40, the last 2 small. Color of dorsal and ventral sides, as also elytra, is diffused purple, but the dorsum of each segment has 2 narrow, transverse, beadlike rows of pale spots and a pale segmental groove. There are 14 (or possibly 15) pairs of elythrophones, the last pair tiny.

The prostomium is paler, but purplish, like the rest of the body. It is nearly twice as broad as long, its lobes bulging and terminating distally in minute peaks. There is a distinct median sulcus. The 4 eyes are disposed at the sides, posterior to the widest part of the prostomium. The median ceratophore is inserted near the anterior end, its style lost (fig. 1, *f*). Paired prostomial antennae are long, tapering, but greatly exceeded in length by the palpi. The latter are somewhat annulated in their basal halves. The distal half tapers gradually and ends in a blunt tip. The palpi are over twice as long as the paired prostomial antennae.

Parapodia are elongate, the acicular lobes drawn out in a tip, from which the pale acicula project. The notosetal fascicles are less than

half as heavy as the neurosetal, and their setae extend laterally only about as far as the bases of the neuropodial setae. Notopodial setae are stouter than the neuropodial setae, they are serrated along their lateral edge and end in a blunt, bifid tip (fig. 1, *j*). Neuropodial setae are much more numerous, and finer; the superiormost has a long serrated blade (fig. 1, *k*), which is about four times as long as that of the inferiormost seta (fig. 1, *i*).

The elytra appear smooth, with entire margins, but under low magnification they are seen to have minute marginal papillae (fig. 1, *g*) and some widely spaced elytral tubercles, posterior to the elytral scar. The larger tubercles are unique in that a harder, chitinous basal portion supports a soft, terminal papilla (fig. 1, *h*).

This individual approaches the description of *S. tentaculatus* Horst (1917, p. 100) in some respects, but it differs in having notopodial setae that are distinctly serrated.

## POLYDONTIDAE

### PEISIDICE ASPERA Johnson

*Peisidice aspera* JOHNSON, 1897, p. 184.

*Collection*.—Station No. 20-38; 1 specimen.

A minute specimen, less than 5 mm. long, with only about 30 setigerous segments, and only 16 pairs of elytra. The dorsum is medially exposed and discloses a papillated dorsal body surface. Since this was taken from the anchor chain, it may represent an early, settling, postlarval stage.

*Distribution*.—Central and southern California; Alaska; British Columbia; Galápagos. This record extends the range far to the south, into tropical waters.

## SIGALIONIDAE

### EUSIGALION SPINOSUM Hartman

*Eusigalion spinosum* HARTMAN (Allan Hancock Foundation, in press).

*Collection*.—Station No. 5-38; 1 specimen.

Length 40 mm., consists of 90 segments, a posterior portion missing. Pale or white, with a dusky longitudinal stripe over the neural area. Elytra white, firmly attached.

*Distribution*.—Southern California, south to Lower California, Mexico.

## CHRYSOPETALIDAE

## PALEANOTUS CHRYSOLEPIS Schmarda

*Palcanotus chrysolepis* SCHMARDA, 1861, p. 163; MONRO, 1933, p. 19.  
*Heteropale bellis* JOHNSON, 1897, p. 163.

*Collection*.—Station No. 3-38; 1 specimen.

Immature, about 8 mm. long; agrees well with Johnson's description of *Heteropale bellis* (1897, p. 163). It is uniformly straw-colored in preservative.

*Distribution*.—Cape of Good Hope; Australia; western Canada south to Lower California; Mexico; Panama.

## AMPHINOMIDAE

## EURYTHOË COMPLANATA (Pallas)

*Eurythoë complanata* AUGENER, 1913, p. 87; CHAMBERLIN, 1919, p. 28.

*Collection*.—Station Nos. 9-38, 30-38. 12 specimens.

Length to 60 mm.

*Distribution*.—Cosmopolitan, in warmer waters.

## HERMODICE CARUNCULATA (Pallas)

*Hermodice carunculata* FAUVEL, 1923, p. 130.

*Collection*.—Station No. 30-38; 3 specimens.

Length to 68 mm.

*Distribution*.—Indian Ocean; warmer waters of eastern and western Atlantic; West Indies.

## CHLOEIA ENTYPA Chamberlin

*Chloëia entypa* CHAMBERLIN, 1919, p. 30; TREADWELL, 1937, p. 147.

*Collection*.—Station No. 28-38; 1 specimen.

Tiny, with only 12 setigerous segments and a posterior growth zone. The proboscis is protruded, forming a large, corrugated, globular sack on the ventral side of the prostomium and first 2 segments. The dorsum has weak longitudinal stripes.

*Distribution*.—Southern California, south to Panama.

## PHYLLODOCIDAE

## ANAITIDES LAMELLIFERA (Pallas)

FIG. 2, a

*Phyllodoce (Anaitides) lamellifera* MONRO, 1933, p. 22.

*Phyllodoce lamelligera* FAUVEL, 1923, p. 147.

*Collection*.—Station No. 9-38; 1 specimen.

Length about 108 mm., number of segments about 279; long, slender, the parapodia held at right angles to the body, and con-

spicuous throughout. Color pale, with traces of a dark transverse band across the middle dorsum of each segment in the anterior region. Third tentacular segment without setae.

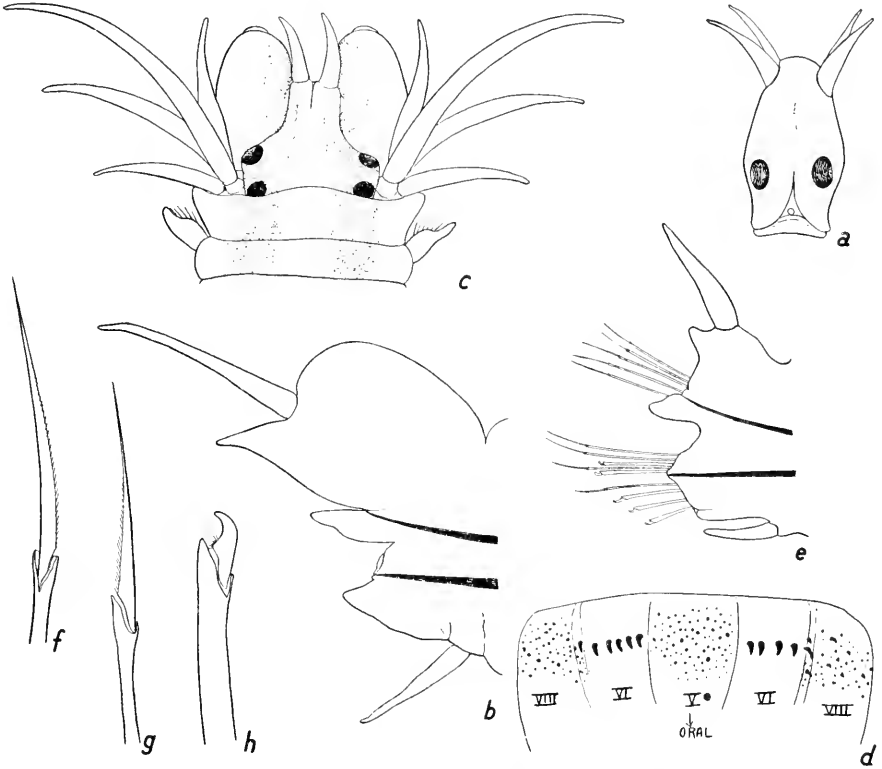

FIG. 2.—Species of *Anaitides*, *Nereis*, and *Ncanthes*.

*a*, *Anaitides lamellifera*: prostomium, in dorsal view, showing median sulcus and nuchal papilla,  $\times 21$ ; *b*, *Nereis callaona*: 50th parapodium, or 10th last, with large dorsal ligules,  $\times 44$ ; *c-h*, *Ncanthes roosevelti*: *c*, prostomium and first two segments, palpi somewhat turned under; stippling indicates areas of brown pigmentation,  $\times 44$ ; *d*, portion of protruded proboscis, including areas V, VI and parts of VIII,  $\times 44$ ; *e*, 38th parapodium, or 12th last, from left side, in posterior view,  $\times 86$ ; *f*, homogomph notopodial seta from 38th parapodium,  $\times 430$ ; *g*, heterogomph, spinigerous neuropodial seta, from 38th parapodium,  $\times 430$ ; *h*, heterogomph falcigerous neuropodial seta, from 38th parapodium,  $\times 430$ .

The prostomium is emarginate at its posterior margin (fig. 2, *a*), contrasting therein with the description of European specimens (see Fauvel, 1923, fig. 52, *a*) and has an occipital button, contrasting with Monro's specimen from Taboga Island (Monro, 1933, p. 22). The parapodia have approximately the same outlines as shown by Monro (1933, figs. 10, *a*, *b*).

The name, *A. lamellifera* (Pallas), is used instead of *A. lamelligera* Johnston (see Fauvel, 1923, p. 147) for the reasons set forth by Monro (1933, p. 22).

*Distribution*.—Cosmopolitan, in warmer waters; littoral zones.

## HESIONIDAE

### HESIONE INTERTEXTA Grube

*Hesione intertexta* GRUBE, 1878, p. 102; MONRO, 1931, p. 9.

*Hesione panamcha* CHAMBERLIN, 1919, p. 188.

*Collection*.—Station No. 30-38; 1 specimen.

Length 41 mm. The dorsal pigmented pattern consists of a white, transverse band across the parapodial ridge, between which are from 5 to 7 more or less regular transverse bands of brown, broken by narrow white transverse lines. The prostomial antennae are tiny; the 8 pairs of peristomial cirri are all fairly long. The guard of the composite setae approaches the apical tooth (see Monro, 1931, p. 9).

*Distribution*.—Philippines; Great Barrier Reef; Brazil; Panama. Lower California, Mexico; Caribbean Sea.

## SYLLIDAE

### SYLLIS FUSCOSUTURATA Augener

*Syllis fuscoturata* AUGENER, 1922, p. 43; MONRO, 1933, p. 32.

*Collection*.—Station Nos. 15-38, 16-38; 5 specimens.

The prostomium and setae are well illustrated by Monro (1933, p. 32). Identification with Augener's species is uncertain for the same reasons Monro has given (1933, p. 34).

*Distribution*.—West Indies; Panama; Galápagos?

### SYLLIS HYALINA Grube

*Syllis hyalina* FAUVEL, 1923, p. 262.

*Collection*.—Station No. 15-38; 2 specimens.

*Distribution*.—Cosmopolitan.

## NEREIDAE

### UNCINEREIS AGASSIZI (Ehlers)

*Nereis agassizi* EHLERS, 1868, p. 542; JOHNSON, 1901, p. 399.

*Nereis notomacula* TREADWELL, 1914, p. 191.

*Uncinereis subita* CHAMBERLIN, 1919, p. 215.

*Uncinereis agassizi* HARTMAN, 1938a, p. 15.

*Collection*.—Station Nos. 3-38, 4-38, 5-38; over 60 specimens.

To 40 mm. long; none are in the epitokous stage. As typical of the more northern representatives, the stout notopodial uncinigerous

hooks, which characterize this genus, have no indication of a suture, but are strictly simple. The segments of the posterior half of the body have characteristic dark color patches on the dorsal side of the parapodia, and over the body segments, in line with the parapodia.

*Distribution.*—Japan; northeast Pacific, from Alaska south to Lower California, Mexico; Australia; Galápagos Islands.

### ? *NEREIS CALLAONA* Grube

FIG. 2, *b*

*Nereis callaona* GRUBE, 1850, p. 165; AUGENER, 1918, p. 184.

*Nereis heterocirrata* TREADWELL, 1931, p. 1; HARTMAN, 1938, p. 14.

*Nereis eucaipitis* HARTMAN, 1936, p. 468.

*Collection.*—Station No. 3-38; 2 specimens.

Length 24 and 34 mm.; number of segments 60. Color pale, eyes deep red; aciculae are black with paler tips; setae are amber-colored. Posterior parapodia are characterized by having a broad, convex dorsal lobe (fig. 2, *b*). The arrangement of paragnaths is as follows: Area I with 2 cones in tandem, the one on the oral side the larger; area II with a crescent of about 18 cones, ranging from small flat cones near the jaws to tall cones more distally; area III with oval patch of about 25, in 3 or 4 irregular rows, the largest paragnaths on the oral side; area IV with a crescent including about 25 cones resembling those on area III; area V with none; area VI with 4 in a diamond or with 6 to 8 disposed in 2 transverse rows; areas VII and VIII with a continuous series of about 4-6 rows, of many (over 100) smaller cones, separated from one another, the row on the maxillary side with the larger cones. The jaws are burnt amber, translucent, with about 5 poorly marked teeth, the fang proportionately long.

The identity of these two specimens with *N. callaona* is in some doubt because of the greater number of paragnaths on the oral ring; these are disposed in more than 2 transverse rows on areas VII and VIII. *Nereis heterocirrata* Treadwell is obviously the same as *Nereis callaona* Grube, a possibility that Fauvel has already pointed out (in litt.).

### *NEANTHES ROOSEVELTI*, n. sp.

FIGS. 2, *c-h*

*Collection.*—Station No. 15-38; 2 specimens.

Length to 10 mm., number of setigerous segments to 50. The dorsum crossed by dark brown, segmental, transverse bands; a similar pigment on the sides of the prostomium and the inner sides of the palpi.

The prostomium is dorsally flattened, its basal half as broad as the prostomium is long; provided with 4 well-separated dark eyes, disposed in a rectangle; the anterior half of the prostomium narrows rapidly to a blunt, truncate anterior margin, where the prostomial antennae are inserted (fig. 2, *c*). The prostomial antennae are white, their bases nearly touching, they extend distally almost as far as the palpi when the latter are directed forward. The palpi are pale, with brown pigment on their inner faces; they are inserted at the sides of the prostomial lobe so as to leave only a small space between their bases and those of the prostomial antennae.

Peristomial cirri are pale, short; the longest extends posteriorly to about the fifth parapodial segment, the shortest about as long as the prostomial antennae. The peristomial ring is only slightly longer than the next segment (fig. 2, *c*).

The paragnathal armature consists of the following: Area I with 2 larger, pointed cones in tandem and about 50 smaller cones of varying sizes covering the space between the paired areas on II; area II with 8-10 larger cones, about as large as those on area IV (areas I and II are confluent); area III with about 20 larger cones, these disposed in a longer outer row of 7 cones, and 2-3 shorter rows of similar cones; area IV with about 12 larger cones in 2 crescentic rows (areas III and IV are continuous). The cones on areas III and IV are the largest on the proboscis. Area V with about 50 minute cones, separated from one another and completely filling the space between the paired areas VI (fig. 2, *d*); area VI with 5 large, pointed cones disposed in a straight, transverse line, continuous with areas VIII; areas VII and VIII form a broad, continuous zone about one-half as broad as the oral ring is long, consisting of many tiny cones (well over 100) and a few larger points scattered among the tiny points. These paragnaths compare in size and form with those on areas I and V. The jaws are dark brown, with a curved fang and about 5 oblique teeth.

Parapodia are lateral, the setigerous lobes moderately stout but not conspicuous. The dorsal ligule is approximately equitriangular in anterior parapodia, its dorsal cirrus inserted on its dorsal, proximal base, and about twice as long as the ligule. Posteriorly, the dorsal ligule decreases gradually in size, and by the fortieth segment is much smaller than the dorsal cirrus (fig. 2, *c*). Ventral cirri are pale, small, not extending distally as far as the ventral lobe (fig. 2, *e*).

Setae include (1) homogomph spinigers, with fairly short, serrated blade (fig. 2, *f*), (2) heterogomph spinigers, resembling the first in



size and form (fig. 2, *g*), and (3) falcigerous heterogomph falcigers (fig. 2, *h*) in neuropodia. There are no homogomph falcigers.

*Neanthes roosevelti* approaches *N. cricognatha* Ehlers (1905, p. 29) from New Zealand, in having a large number of paragnaths. It differs, however, in having them disposed otherwise; also, the posterior parapodial lobes differ in being much reduced in this species.

It is a pleasure to dedicate this species to the Honorable Franklin Delano Roosevelt, President of the United States, who sponsored the scientific studies made on the Presidential Cruise of 1938.

*Holotype*.—U.S.N.M. no. 20427.

## EUNICIDAE

### EUNICE BIANNULATA Moore

*Eunice biannulata* MOORE, 1904, p. 487.

*Eunice longicirrata*, var., HARTMAN, 1938b, p. 97.

*Collection*.—Station No. 8-38; 1 specimen.

Length about 30 mm.; parapodial segments 2, 3, and 7 pale. Composite setae distally bifid; the stout simple hooks are bifid. Dorsal cirri faintly annulated.

*Distribution*.—Western Canada south to southern California; Socorro Island, Mexico.

### EUNICE AEDIFICATRIX Monro

FIGS. 3, *a-b*

*Eunice antennata* SAVIGNY, *aedificatrix* MONRO, 1933, p. 60.

*Collection*.—Station Nos. 3-38, 5-38; 2 specimens.

An anterior fragment of 83 segments is 36 mm. long and 4.5 mm. wide (station No. 5-38); another with 31 anterior segments is only 12 mm. long. The prostomial antennae are closely moniliform, with 12 to 15 articles. The peristomial tentacles are nearly smooth and about two-thirds as long as the peristomial ring. The branchiae are present from the sixth setigerous segment; they are pinnate, the first with 3 filaments which are shorter and weaker than the dorsal cirri, the second have 6 filaments, the third 10 filaments, increasing to 15 filaments at the fifteenth parapodium. From the twenty-fifth to the thirtieth segments the branchiae diminish in size, and at the fortieth they do not extend distally much beyond the dorsal cirri. At the eighty-third segment they are still present with 5 pinnate filaments. Posterior simple hooks are trifold (fig. 3, *b*).

This differs from *E. antennata* Savigny in that the branchiae diminish in size after the thirtieth segment; the peristomial cirri are not annulated; the composite setae are distally bifid (fig. 3, *a*).

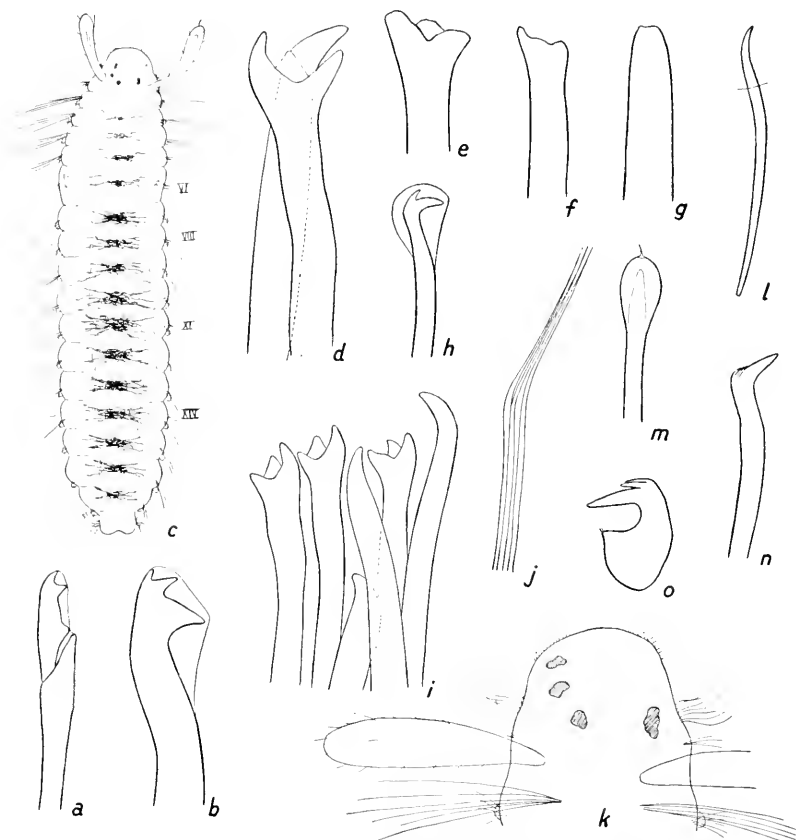

FIG. 3.—Species of *Eunice*, *Polydora*, *Cirratulus*, and *Metachone*.

*a-b*, *Eunice aedificatrix*: *a*, composite seta, with bifid tip,  $\times 195$ ; *b*, simple, uncingerous seta, with trifid tip,  $\times 195$ .

*c-k*, *Polydora tricuspis*: *c*, a planktonic larva, in dorsal view, showing characteristic pigmented pattern, rounded prostomium, paratrochs on segments VI, VIII, XI, and XIV, and parapodial glands in segments VIII to XII, somewhat depressed under cover slip,  $\times 60$ ; *d*, a falcigerous and a tricuspid seta, unworn, from the dorsal fascicle of the 6th segment,  $\times 430$ ; *e* and *f*, worn tricuspid setae from the same fascicle as that shown in figure *d*,  $\times 430$ ; *g*, a worn falcate seta from the same fascicle,  $\times 430$ ; *h*, a hooded crotchet for a neuropodium posterior to the 8th segment,  $\times 430$ ; *i*, stout books from planktonic larva,  $\times 570$ ; *j*, fascicle of capillary setae ventral to the hooks shown in *i*,  $\times 570$ ; *k*, anterior end of a 16-segmented larva showing small setal fascicle in segment I, and reduced neuropodial fascicle in II, depressed under cover slip,  $\times 180$ .

*l*, *Cirratulus niger*: an uncingerous seta from a median parapodium,  $\times 195$ .

*m-o*, *Metachone mollis*: *m*, a spatulate notopodial seta, with minute mucron,  $\times 195$ ; *n*, a thoracic uncinus, from a median thoracic parapodium,  $\times 195$ ; *o*, abdominal uncinus, from an anterior abdominal parapodium,  $\times 195$ .

Monro described a parchment tube with specimens from Panama. No tubes were collected with the specimens at hand.

*Distribution.*—Panama; Lower California, Mexico.

#### EUNICE SCHEMACEPHALA Schmarda

*Eunice schemacephala* SCHMARDA, 1861, p. 132; AUGENER, 1925, p. 28.

*Eunice fucata* EHLERS, 1887, p. 91.

*Collection.*—Station No. 30-38; 2 specimens.

Two sexually mature individuals, one a male, the posterior portions broken and turgid with white gonadal products, the other a gravid female, the eggs olive green in alcohol. Setae are pale straw color, acicula dark.

Augener (1925, p. 28) has discussed the synonymy of this common West Indian species, and at the same time identified his west African *E. fucata* (1918, p. 316) with another species.

*Distribution.*—West Indies; Florida; Caribbean Sea.

#### EUNICE (PALOLO) SICILIENSIS Grube

*Eunice siciliensis* FAUVEL, 1923, p. 405; MONRO, 1933, p. 62.

*Collection.*—Station No. 9-38; 2 specimens.

An anterior fragment with about 65 segments is 16 mm. long and 2.5 mm. wide. It is pale except for black eyes and dark acicula. Heavy white calcareous mandibles protrude partly from the mouth. Branchiae are present from the forty-seventh parapodium to the end of the piece as simple filaments, exceeding the dorsal cirri in length. Composite setae are pale, distally blind. There are no simple neuropodial hooks.

Another specimen about 25 mm. long consists of about 100 posterior segments with anal ring, and a regenerated anterior end including prostomium and about 25 anterior segments. The ability to regenerate lost anterior parts is not uncommon in this family.

*Distribution.*—Cosmopolitan, in tropical and subtropical seas.

### CHAETOPTERIDAE

#### MESOCHAETOPTERUS MINUTUS Potts

*Mesochaetopterus minutus* POTTS, 1914, p. 963; MONRO, 1928, p. 92; 1933, p. 1052.

*Collection.*—Station No. 9-38; many tubes, some with their inhabitants.

Numerous light, sand-covered tubes, to 50 mm. long and about 1 mm. wide. The sand covers a transparent chitinous tube in which

no annulations were observed. The occupants are difficult to extract entire from the slender tubes, but are probably very much shorter than the tubes they occupy.

*Distribution.*—Cape Verde Islands; Torres Strait Settlements; Galápagos Islands; Clipperton Island.

## SPIONIDAE

### POLYDORA TRICUSPA, n. sp.

FIGS. 3, *c-k*

*Collection.*—Station No. 15-38; 1 specimen.

Length of 30 anterior segments is 5 mm., width 0.6 mm. Colorless except for 3 black eye spots, 2 of which are anterior, at the sides of the prostomium, and an unpaired one more posteriorly, on the prostomial ridge. A dark stripe marks the dorsal longitudinal vessel.

The prostomium is rounded anteriorly, snoutlike, its length about as great as the base of the head is wide at the place where the palpi are inserted. The prostomial caruncle extends posteriorly as a low ridge to the anterior margin of the modified segment. The palpi have been lost.

Branchiae are present from segment 8 (the second post modified) to segment 25, or 18 pairs. They are cirriform, recurved over the dorsum, slightly overlapping except in the last 3 branchial segments, where they are shorter.

The second segment (first setigerous) has a dorsal fascicle of lanceolate setae. Segments 3-5 have lanceolate setae in notopodial and neuropodial fascicles. Segment 6 is modified, provided with 2 kinds of stout uncini in the dorsal fascicle, and a small fascicle of slender lanceolate setae ventrally. The stout uncini include 4-5 pairs of (1) longer, pointed spines bent at the tip (fig. 3, *d*), and (2) equally heavy, though somewhat shorter, triple pronged spines, accompanying the pointed spines (fig. 3, *d*). On worn spines (figs. 3, *e-g*) the tips are missing. No fine penmoned, companion setae were distinguished. Bifid hooded crotchets are present in neuropodia from the eighth segment. They have a long main fang, nearly at right angles to the main stem, and a distal tooth less than half as large (fig. 3, *h*). All notopodia have only lanceolate setae.

This single specimen is of unique interest because of its relation to observations made on planktonic larval forms during March to April, 1938. These studies were carried on at the Scripps Institution of Oceanography at La Jolla, Calif., under the sponsorship of Dr.

Martin W. Johnson. Plankton tows were made from the end of a 1,000-foot pier, along the open ocean. Frequently these tows contained larvae of a *Polydora* in which the modified hooks and hooded crotchets are strikingly like those in the unique specimen from James Island (cf. figs. 3, *i* and 3, *d*). Also, these pelagic larvae had up to 19 setigerous segments, indicating a long pelagic life, and hence the possibility of being widely disseminated by ocean currents. In spite of shore collecting in the vicinity of La Jolla, the adults were not recovered. Subintertidal zones were not examined.

These larvae are characterized as follows (based on living larvae): Each setigerous segment has a single black, irregular blotch over the middle dorsum; the prostomium is broadly rounded anteriorly (fig. 3, *c*); there are 4 (more or less) eye spots; the palpi are stout, short; ciliated paratrochs are present on segments VI (modified), VIII, XI, XIV, and ciliated rings on the peristomium and anus. Parapodial glands are visible in segments VIII to XII (fig. 3, *c*); the first segment (= peristomium) has a few short ventral setae which are perhaps lost later; the second segment has both dorsal and ventral fascicles, the ventral setae much the shorter, and not present in the adult (fig. 3, *k*); hooded crotchets are present from segment VIII; segment VI has two kinds of stout modified hooks (fig. 3, *i*) identical with those in the specimen from the Galápagos Islands and a slender fascicle of 4 or 5 capillary setae (fig. 3, *j*). No branchiae are visible.

*Polydora tricuspa* differs from other species of *Polydora* in that the modified segment (VI) has 2 kinds of stout hooks, a falcate and a tricuspid, in addition to a ventral fascicle of lanceolate setae. The hooked crotchets are bifid; branchiae are limited to 18 segments.

*Holotype*.—U.S.N.M. no. 20428.

*Distribution*.—Galápagos Islands; southern California.

## CIRRATULIDAE

### CIRRATULUS NIGER, new name

FIG. 3, b

*Cirratulus nigromaculata* TREADWELL, 1902, p. 204, *not* GRUBE, 1870, p. 504.

*Collection*.—Station No. 8-38; 3 specimens.

Length to 13 mm., widest at about the tenth setigerous segment. General appearance dark, with pale tentacular cirri and white branchial filaments. Head and anterior end as shown by Treadwell (1902, p. 204). Under high magnification the dark color resolves itself into diffuse dusky patches, darkest over the middorsum in the anterior

region. The prostomium is pale with a dark, median, longitudinal stripe. The white branchial cirri have narrow black rings. Parapodial tentacular filaments posterior to the branchial region are dark with a subdistal white ring, and a terminal dark point.

The setae are pale, inconspicuous, and include pointed capillaries in both rami of the first 7 segments. More posteriorly, pointed setae alternate with thicker, uncinigerous setae. The latter are slightly curved (fig. 3, *l*) and terminate in a blunt point.

*Cirratulus nigromaculata* Treadwell is preoccupied by Grube (1870, p. 504) for a species from the Red Sea. A new name is therefore proposed.

*Distribution*.—Panama; Socorro Island, Mexico.

## OPHELIIDAE

### POLYOPHTHALMUS PICTUS (Dujardin)

*Polyopthalmus pictus* FAUVEL, 1927, p. 137.

? *Polyopthalmus australis* TREADWELL, 1914, p. 216.

*Collection*.—Station Nos. 3-38, 5-38; numerous specimens.

Length to 27 mm.; pigment pattern consists of rust-colored, transverse segmental bands dorsally, widest in the first 3 or 4 segments where they almost coalesce, and become narrower more posteriorly. The band is continued on the ventral side but interrupted ventrolaterally along the muscular ridge. There are 12 pairs of lateral eye spots. The prostomium is pale.

*P. australis* Treadwell (1914, p. 216), from southern California, is perhaps this same species, since it is known to occur commonly in the littoral zones of southern California.

*Distribution*.—Cosmopolitan, in warmer waters.

### ARMANDIA, sp.

*Collection*.—Station No. 3-38; 1 specimen.

In a collection with numerous individuals of *Polyopthalmus pictus* (Dujardin). Pale to white except for eye spots. Prostomium with 3 black, embedded eye spots. Consists of 36 setigerous segments. The proboscis is partly everted in the form of 8 dichotomously divided lobes, the largest lobes near the middle of the series. The prostomial lobe (anterior to the mouth) measures about as long as the length from the mouth to the fourth parapodium. Lateral eye spots are oval, black, present from between segments 2/3 to 32/33, though a few are missing. Branchiae are cirriform, present from the second setigerous segment to the second last, or 34 pairs.

The anal tube, without its terminal cirri, is about as long as the last 4 setigerous segments. It ends distally in 6 subequal cirri disposed in a crescent on the dorsal and lateral portions, and 2 ventral cirri, including a longer left and a shorter right, but both are larger than the lateral cirri.

The single individual is translucent, and believed to be immature. It differs from known species of *Armandia* in (1) its greater number of segments (36 setigerous), (2) the presence of lateral eye spots posterior to the seventeenth segment, and (3) the small number of anal cirri, a total of 8.

## SABELLARIIDAE

### IDANTHYRSUS PENNATUS (Peters)

*Pallasia pennata* FAUVEL, 1917, p. 262.

*Idanthyrus pennatus* MONRO, 1933b, p. 1005.

*Collection*.—Station Nos. 9-38, 15-38; 1 specimen and dried tubes.

Length to 55 mm. (Clipperton Island). The inside diameter of the tubes is approximately 5 mm.; the outer surface is covered with coarse yellow sand particles and shell fragments.

*Distribution*.—Cosmopolitan; littoral zones.

## TEREBELLIDAE

### NICOLEA GALAPAGENSIS Chamberlin

*Nicola galapagensis* CHAMBERLIN, 1910, p. 427.

*Nicola cetrata galapagensis* AUGENER, 1933, p. 65.

*Collection*.—Station No. 19-38; 1 specimen.

Length without tentacles about 50 mm.; color drab greenish gray in alcohol. There are 2 pairs of branchiae, the first somewhat larger than the second; and 19 ventral thoracic scutes, the last two not well marked.

*Distribution*.—Galápagos Islands; Australia (Augener).

### POLYMNIA NEBULOSA (Montagu)

*Polymnia nebulosa* FAUVEL, 1927, p. 257; MONRO, 1933b, p. 1072; OKUDA, 1937, p. 59.

*Collection*.—Station No. 30-38; 3 specimens.

The longest to 50 mm, without the tentacles, consists of 125 setigerous segments of which 17 are thoracic.

*Distribution*.—Cosmopolitan, in warm seas.

## SABELLIDAE

## SABELLASTARTE INDICA (Savigny)

*Sabellastarte indica* AUGENER, 1914, p. 115; MONRO, 1933b, p. 1079.

*Collection*.—Station No. 30-38; 1 specimen in tube.

Length, removed from tube, is 73 mm., of which the tentacles comprise 33 mm., and the abdomen 35 mm. Color in alcohol is brownish red.

*Distribution*.—Cosmopolitan, in warmer seas.

## METACHONE MOLLIS Bush

FIGS. 3, *m-o*

*Metachone mollis* BUSH, 1904, p. 216.

*Collection*.—Station Nos. 3-38, 5-38; 8 specimens.

Length to 25 mm. without branchial crown, width to 5 mm.; number of segments to 44, including 8 thoracic setigerous segments and 24-36 abdominal segments. The branchial crowns are lost from the larger specimens. On the smaller (9 mm. long) individuals there are 6 pairs of filaments, the branchial web extends distally to within one-third or one-fourth of the ends of the filaments.

Thoracic spatulate setae have an inconspicuous mucron (fig. 3, *m*), obsolete in some. The thoracic uncini have a stout proximal fang and about 3 smaller teeth (fig. 3, *n*). Abdominal uncini have teeth resembling those of the thoracic uncinigers but are not stalked (fig. 3, *o*). The collar is entire, straight, the lobes not prolonged.

*Distribution*.—California, south to Lower California, Mexico.

## LITERATURE CITED

## AUGENER, HERMANN

1913. Polychaeta Errantia. Die Fauna Südwest Australiens, Band 4, pp. 95-304, 42 figs., 2 pls.
1914. Polychaeta II. Sedentaria. Die Fauna Südwest Australiens, Band 5, pp. 1-170, 19 figs. 1 pl.
1918. Beiträge zur Kenntnis der Meeresfauna Westafrikas. Polychaeta, pp. 67-625, 111 figs. 6 pls.
1922. Über litorale Polychaeten von Westindien. Sitz. Ges. Naturf. Berlin, 1922, pp. 38-53.
1925. Über westindische und einige andere Polychaeten-Typen von Grube (Örsted) Krøyer, Mörch und Schmarða. Publ. Univ. Zool. Mus., Copenhagen, no. 39, 47 pp., 2 figs.
1933. The Norwegian zoological expedition to the Galapagos Islands 1925, conducted by Alf Wollebaek. VI. Polychaeten von den Galapagos-Insehn. Medd. Zool. Mus., Oslo, nr. 32, pp. 55-66, 1 fig.



## BUSH, KATHARINE JEANNETTE

1904. Tubicolous annelids of the tribes Sabellides and Serpulides from the Pacific Ocean. Harriman Alaska Expedition, Annelids, vol. 12, pp. 169-355, 24 pls.

## CHAMBERLIN, RALPH VARY

1919. The Annelida Polychaeta. Mem. Mus. Comp. Zoöl., vol. 48, 514 pp., 80 pls.

## EHLERS, ERNST

1868. Die Borstenwürmer nach systematischen und anatomischen Untersuchungen dargestellt. Leipzig, 12 + 748 pp., 24 pls.
1887. Report on the Annelids. Mem. Mus. Comp. Zoöl., vol. 15, 6 + 335 pp., 60 pls.
1905. Neuseeländische Anneliden. Abh. K. Ges. Wiss., Göttingen, Math.-Phys. Kl., neue Folge, vol. 3, 80 pp., 9 pls.

## FAUVEL, PIERRE

1917. Annélides polychètes de l'Australie méridionale. Arch. Zool., Paris, vol. 56, pp. 159-278, 6 pls.
1923. Polychètes errantes. Faune de France, vol. 5, 488 pp., 181 figs.
1927. Polychètes sédentaires. Faune de France, vol. 16, 494 pp., 152 figs.

## GRUBE, ADOLPH EDUARD

1856. Annulata Örstediana. Naturhist. Foren. Vid. Medd. Dansk. Nat. Fören., Copenhagen, 1856, pp. 158-186.
1870. Beschreibungen neuer oder weniger bekannter von Hr. Ehrenberg gesammelter Anneliden des Rothen Meeres. Monatsb. Akad. Wiss. Berlin, 1869, pp. 484-521.
1876. Bemerkungen über die Familie der Aphroditeen. 53ter Jahresber. Schles. Ges., für vaterl. Cultur (1875), Breslau, pp. 46-72.
1878. Annulata Semperiana. Beiträge zur Kenntniss der Annelidenfauna der Philippinen nach den von Herrn Prof. Semper mitgebrachten Sammlungen. Mem. Acad. Sci. St. Petersburg, vol. 25, 9 + 300 pp., 15 pls.

## HARTMAN, OLGA

1936. New species of polychaetous annelids of the family Nereidae from California. Proc. U. S. Nat. Mus., vol. 83, pp. 467-480, 8 figs.
- 1938a. Nomenclatorial changes involving types of polychaetous annelids of the family Nereidae in the United States National Museum. Journ. Washington Acad. Sci., vol. 28, pp. 13-15.
- 1938b. Descriptions of new species and new generic records of polychaetous annelids from California of the families Glyceridae, Eunicidae, Stauro nereidae, and Opheliidae. Univ. California Publ. Zool., vol. 43, pp. 93-112, 63 figs.

## HORST, RUTGER

1917. Polychaeta Errantia of the Siboga Expedition. Aphroditidae and Chrysopetalidae. Siboga Expedition, vol. 24b, pp. 41-143, 5 figs., 19 pls.

## JOHNSON, HERBERT PARLIN

1897. A preliminary account of the marine annelids of the Pacific Coast, with descriptions of new species. Proc. California Acad. Sci., ser. 3, Zool., vol. 1, pp. 151-198, 6 pls.
1901. The Polychaeta of the Puget Sound region. Proc. Boston Soc. Nat. Hist., vol. 29, pp. 381-437, 19 pls.

## MONRO, CHARLES CARMICHAEL ARTHUR

- 1928a. Polychaeta of the families Polynoidea and Acoetidae from the vicinity of the Panama Canal, collected by Dr. C. Crossland and Dr. Th. Mortensen. Journ. Linnean Soc. London, vol. 36, pp. 553-576, 30 figs.
- 1928b. On the Polychaeta collected by Dr. Th. Mortensen off the coast of Panama. Vid. Medd. Dansk Nat. Foren., vol. 85, pp. 75-103, 19 figs.
1931. Polychaeta, Oligochaeta, Echiuroidea, and Sipunculoidea. Scientific Reports, vol. 4, pp. 1-37, 15 figs.
- 1933a. The Polychaeta Errantia collected by Dr. C. Crossland at Colon, in the Panama region, and the Galapagos Islands during the expedition of the S.Y. *St. George*. Proc. Zool. Soc. London, 1933, pp. 1-96, 36 figs.
- 1933b. The Polychaeta Sedentaria collected by Dr. C. Crossland at Colon, in the Panama region, and the Galapagos Islands during the expedition of the S.Y. *St. George*. Proc. Zool. Soc. London, 1933, pp. 1039-1062, 31 figs.

## MOORE, JOHN PERCY

1904. New Polychaeta from California. Proc. Acad. Nat. Sci. Philadelphia, 1904, pp. 484-503, 2 pls.
1911. The polychaetous annelids dredged by the U.S.S. *Albatross* off the coast of southern California in 1904: III. Euprosynidae to Gonididae. Proc. Acad. Nat. Sci. Philadelphia, 1911, pp. 234-318, 7 pls.

## OKUDA, SHIRO

1937. Annelida Polychaeta in Onagawa Bay and its vicinity. I. Polychaeta Sedentaria. Sci. Rep. Tôhoku Imp. Univ., ser. 4, vol. 12, pp. 45-69, 12 figs., 1 pl.

## POTTS, F. A.

1914. Polychaeta from the northeast Pacific. The Chaetopteridae. Proc. Zool. Soc. London, 1914, pp. 955-994, 6 pls.

## SCHMARDA, LUDWIG KARL

1861. Neue wirbellose Thiere beobachtet und gesammelt auf einer Reise um die Erde 1853-57, vol. 1, pt. 2, 164 pp., 100 figs., 22 pls.

## TREADWELL, AARON L.

1902. The polychaetous annelids of Porto Rico. Bull. U. S. Fish Comm., vol. 20 (for 1900), pt. 2, pp. 181-210, 81 figs.
1914. Polychaetous annelids of the Pacific coast in the collections of the zoological museum of the University of California. Univ. California Publ. Zool., vol. 13, pp. 175-238, 7 figs., 2 pls.
1928. Polychaetous annelids from the *Arcturus* Oceanographic Expedition. Zoologica, New York, vol. 8, pp. 449-485, 3 figs.
1931. Three new species of polychaetous annelids in the collections of the United States National Museum. Proc. U. S. Nat. Mus., vol. 80, pp. 1-5, 3 figs.
1937. Polychaetous annelids from the west coast of Lower California, the Gulf of California and Clarion Island. Zoologica, New York, vol. 22, pp. 139-160, 2 pls.

SMITHSONIAN MISCELLANEOUS COLLECTIONS  
VOLUME 98, NUMBER 14

TWO NEW GOBIOID FISHES COLLECTED  
ON THE PRESIDENTIAL  
CRUISE OF 1938

BY  
ISAAC GINSBURG  
U. S. Bureau of Fisheries

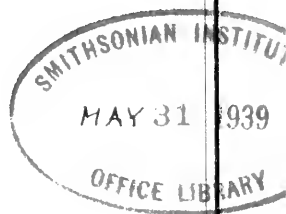

(PUBLICATION 3539)

CITY OF WASHINGTON  
PUBLISHED BY THE SMITHSONIAN INSTITUTION  
MAY 31, 1939



SMITHSONIAN MISCELLANEOUS COLLECTIONS  
VOLUME 98, NUMBER 14

TWO NEW GOBIOID FISHES COLLECTED  
ON THE PRESIDENTIAL  
CRUISE OF 1938

BY  
ISAAC GINSBURG  
U. S. Bureau of Fisheries



(PUBLICATION 3539)

CITY OF WASHINGTON  
PUBLISHED BY THE SMITHSONIAN INSTITUTION  
MAY 31, 1939

The Lord Baltimore Press  
BALTIMORE, MD., U. S. A.

## TWO NEW GOBIOID FISHES COLLECTED ON THE PRESIDENTIAL CRUISE OF 1938<sup>1</sup>

BY ISAAC GINSBURG  
*U. S. Bureau of Fisheries*

Two very interesting species of fishes, an eleotrid and a gobiid, which proved to be unknown to science, were collected during the 1938 Presidential cruise, on Old Providence Island. Both diverge from the known species in their respective genera to a remarkable extent, and present features that should prove to be of value in interpreting the phylogenetic relationship of some species in this difficult and interesting assemblage of related species.

Numerical values of measurements stated in this paper refer to percentages in standard length. The given length of a specimen represents the total length, including the caudal fin, unless otherwise stated.

### **PYCNOMMA ROOSEVELTI**, n. sp.

*Description.*—Form elongate, body compressed, head conspicuously depressed. Snout blunt, especially when viewed from dorsal aspect. Mouth moderately oblique, terminal; a horizontal through distal margin of upper lip approximately bisecting eye; lower jaw slightly projecting. Maxillary medium, its posterior end approximately under middle of eye. Interorbital narrow. Tongue free, broad, with a nearly straight edge in front, only very slightly emarginate. Teeth in 3 rows, those in outer and inner rows enlarged; in upper jaw teeth in outer row strongly enlarged, extending nearly to angle of mouth, inner teeth moderately enlarged near symphysis only; in lower jaw outer enlarged teeth of about same size as outer teeth of upper jaw, nearly confined to front, not extending far on side, inner row extending about half the distance from symphysis to angle of mouth, the hindmost 2 or 3 very strongly enlarged, caninoid, the middle row of smaller teeth extending nearly to angle of mouth. No spine at angle of preopercle. Scales extending forward to a vertical approximately through origin of first dorsal, in about 26 oblique rows to base of caudal (some of the scales missing and accurate count not possible);

<sup>1</sup> Published by permission of the U. S. Commissioner of Fisheries.

line marking anterior boundary of scales roughly curved, convex anteriorly, resulting in bare areas above and below, that near dorsal profile tapering backward approximately to origin of second dorsal, that at ventral profile to anal opening; anterior scales cycloid, but moderately smaller than posterior ones, the latter moderately spinuliferous, the spinules few in number, confined to the median area, in a single row at margin; caudal with a transverse row of 4 scales at its base, the outer scale in the row, above and below, conspicuously modified, ovoid, the spinules at the side markedly long, gradually decreasing in length toward a median longitudinal line, the 2 middle scales in the row of nearly the same size as the outer ones but rounded in form with the spinules not modified, approximately the same as in adjacent scales on caudal peduncle; no scales on antedorsal distance,

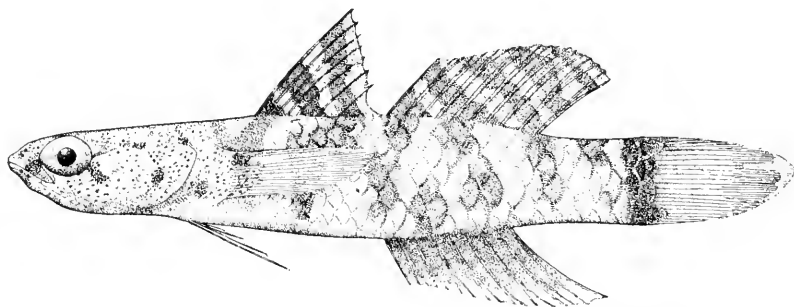

FIG. 1.—*Pycnomma roosevelti*; from the holotype, U.S.N.M. no. 108139; 20 mm. Drawn by Andrew Pizzini.

head, base of pectoral, throat, or midline of belly. First dorsal with 7 flexible spines, the first spine longest, reaching base of first or second dorsal ray, the others gradually decreasing in length. Second dorsal with 10, anal with 9 rays; those of anal nearly reaching a vertical through end of hypural, those of dorsal falling short of that vertical. Pectoral with 16 rays, its tip reaching a vertical approximately through origin of second dorsal. Ventrals completely separated, the tips falling at some distance short of anus. Caudal rather short. Mucous pores present on head.

Body with a diffusely and irregularly cross-banded color pattern, with 6 dark bands against an olive grayish background; the bands broad, somewhat oblique, diffuse, without sharp boundaries, sometimes more or less interrupted; a better-marked, darker, vertical band at base of caudal, partly on fin and partly on caudal peduncle; a transverse, diffusely dark area at anterior margin of opercle; a dark band



from front of eye running obliquely downward and forward, a more diffuse one back of eye running downward and backward; 2 narrow elongate spots on midline of nape; 2 small diffuse spots, one behind the other, back of eye; the 2 dorsals with dark, oblique, bandlike areas, alternated with lighter areas; other fins more or less dusky, anal darkest, becoming nearly black distad; a small dark spot on pectoral near its upper anterior corner, a larger, more diffuse blotch on its fleshy base, below.

*Measurements.*—The type, 16 mm. in standard length. Caudal about 27, ventral 27, pectoral 26, depth 17, least depth of caudal peduncle 14, head 30.5, postorbital part of head 21, head depth directly behind eye 15, head width at same point 19, maxillary 12.5, snout 7.5, eye 8, antedorsal distance 38.5.

*Holotype.*—U.S.N.M. no. 108139; Old Providence Island; August 6, 1938; obtained on the Presidential cruise; W. L. Schmitt collector; about 20 mm., the caudal slightly broken at posterior margin, but apparently representing nearly entire length.

*Paratype.*—Another specimen, 18 mm., obtained with the type.

Both specimens are probably males, judging by the anal papilla, but this structure is not decisively of the male type, and the sex of the two specimens is somewhat doubtful.

*Distinctive characters and relationship.*—This species agrees more nearly with *Pycnomma semisquamatum* Rutter from the Gulf of California, judged by the published account of that species, than with any other known American goby. It differs strikingly from that species in that the squamation extends much farther forward, to under the beginning of the first dorsal, instead of to under its end. The scales in *P. roosevelti* appear to be larger and there are one or two fewer rays in the vertical fins. This is the first species of *Pycnomma* from the Atlantic, and the second species of the genus now to be made known.

This species is named in honor of President Franklin D. Roosevelt.

#### GARMANNIA GEMMATA, n. sp.

*Description.*—Form elongate, head and body compressed. Mouth medium, oblique, terminal, a horizontal through distal margin of upper lip passing nearly through lower margin of eye; lower jaw slightly shorter in front than upper. Maxillary medium, its end falling below space between posterior margins of pupil and eye. Outer row of teeth in both jaws enlarged, smaller teeth behind; outer row of upper jaw extending nearly to angle of mouth, that of lower jaw nearly confined to front; lower jaw with 2 inner caninoids, a little

nearer angle of mouth than symphysis. Shoulder girdle without papillae. No fold in front of dorsal. Isthmus restricted, attachment of branchiostegal membrane at lower angle of pectoral base. Scales confined to caudal peduncle, extending forward to a vertical through base of last dorsal ray. ctenoid, large, imbricated, almost wholly covering caudal peduncle, 5 in a median longitudinal row to base of caudal; 4 large scales in a transverse row on caudal base; no other scales. First dorsal with 7 flexible spines, the first only a little prolonged in male, reaching base of first ray. Second dorsal with 12 or 13 rays; anal with 10 or 11 rays; tip of posterior dorsal rays falling a little short of a vertical through end of hypural, those of anal considerably short. Pectoral with 15 or 16 rays. Ventral short, ending at a consid-

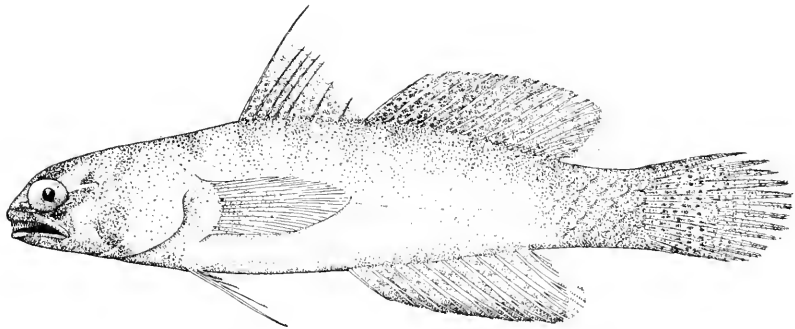

FIG. 2.—*Garmannia gemmata*; from the holotype; U.S.N.M. no. 107291; male, 19 mm. Drawn by Andrew Pizzini.

erable distance before anus; the interspinal membrane not well developed. Caudal short, rounded.

Body nearly uniformly and very moderately dusky; very feeble traces of cross-bands, somewhat better marked when viewed from dorsal aspect; the nearly evenly distributed chromatophores of two sizes, fine and coarser ones, the latter especially numerous on back and caudal peduncle; head darker than body, irregularly shaded. Caudal distinctively and prettily spotted, when viewed under magnification arrangement of very small individual spots as follows: in a large median area near base of fin 1 spot, usually elongate, set like a jewel in every fin ray joint, surrounded marginally by a light region; near upper and lower margins and posteriorly 2 smaller spots, one behind the other, often only 1 and sometimes 3 similar spots similarly set in every joint; the characteristic arrangements of spots disappearing

where rays split to form narrow branches. Anal with a supramarginal, black, diffuse band; rest of fin and other fins more or less dusky, the 2 dorsals darkest.

*Measurements*.—Female 14 mm. in standard length. Ventral 21.5, depth 23, least depth of caudal peduncle 13.5, head 27, postorbital part of head 18, head depth directly behind eye 16.5, head width at same point 14.5, maxillary 12, snout 7, eye 8, antedorsal distance 38. Caudal in a male 19 mm., 23.5.

*Holotype*.—U.S.N.M. no. 107291; Old Providence Island; August 6, 1938, obtained on the Presidential cruise; W. L. Schmitt collector; male 19 mm.

*Paratypes*.—Female 14 mm. in standard length, obtained with the type. Bingham Oceanographic Collection: Barahona Harbor, Santo Domingo; John C. Armstrong; July 13, 1933; female 13 mm. in standard length.

The specimen from Santo Domingo differs somewhat in color from the two from Old Providence Island. There is no trace of crossbands. The prevailing color is considerably darker. It is almost uniformly dark all over, except a large conspicuously lighter area on side and underside of the belly. The lighter area is abruptly delimited from the dark shade on the back; the line of demarcation is a longitudinal through the upper angle of the pectoral. However, in the number of fin rays, the distinctive spotting on the caudal, and its general shape and appearance it agrees with the other 2 specimens. The scales are nearly all missing, but the traces of scale pockets left show that the extent of squamation is about the same as in those 2 specimens. It is apparently conspecific with them.

*Distinctive characters and relationship*.—This species shows a comparatively high degree of divergence from *Gammamia paradoxa* (Günther), the genotype, and the two are evidently relatively remote in their relationship. *G. gemmata* differs strikingly in having the squamation much less extensive and in having a compressed, instead of a depressed, head. Striking differences are also found in the lateral line organs. These structures which have been hitherto neglected in studies of the American gobies will be considered in a systematic manner in a later paper. The new species differs from *paradoxa* also in having fewer pectoral rays.



SMITHSONIAN MISCELLANEOUS COLLECTIONS  
VOLUME 98, NUMBER 15

SMITHSONIAN INSTITUTION  
JUN 21 1939  
OFFICE LIBRARY

# SPONGES COLLECTED ON THE PRESIDENTIAL CRUISE OF 1938

BY  
M. W. DE LAUBENFELS  
Pasadena Junior College



(PUBLICATION 3540)

CITY OF WASHINGTON  
PUBLISHED BY THE SMITHSONIAN INSTITUTION  
JUNE 21, 1939



SMITHSONIAN MISCELLANEOUS COLLECTIONS  
VOLUME 98, NUMBER 15

SPONGES COLLECTED ON THE  
PRESIDENTIAL CRUISE  
OF 1938

BY  
M. W. DE LAUBENFELS  
Pasadena Junior College



(PUBLICATION 3540)

CITY OF WASHINGTON  
PUBLISHED BY THE SMITHSONIAN INSTITUTION  
JUNE 21, 1939

The Lord Baltimore Press  
BALTIMORE, MD., U. S. A.



## SPONGES COLLECTED ON THE PRESIDENTIAL CRUISE OF 1938

BY M. W. DE LAUBENFELS

*Pasadena Junior College*

In the summer of 1938 President Franklin D. Roosevelt made a trip from San Diego to the Galápagos Islands, through the Panama Canal (August 5), stopping at Old Providence Island in the extreme western Caribbean Sea, and thence returning to Washington, D. C. Thirteen species of Porifera were collected and preserved by Dr. Waldo L. Schmitt, of the United States National Museum, Naturalist to the expedition, with assistance from various members of the ship's personnel.

The sponges in the following annotated list are arranged in systematic order. A new species (No. 5 below) of the genus *Merriamium* I take pleasure in naming *M. roosevelti* for the President of the United States, whose interest in marine zoology made possible this very successful expedition. In certain instances reference is made to species which were also collected in the same area by the Hancock Pacific Expeditions on the motor cruiser, *Vclero III*, under the direction of Captain G. Allan Hancock, owner and sponsor.

### ANNOTATED LIST OF SPONGES

1. *Haliclona cnamela* de Laubenfels 1930, p. 28. One specimen collected July 25 at Clipperton Island (Galápagos). This species was originally described from Southern California. It has been collected by Capt. Allan Hancock in Mexico and on Charles Island (Galápagos).
2. *Haliclona permollis* (Bowerbank) 1866, p. 278. Two specimens collected July 26 at Albemarle Island (Galápagos). This species was originally described from British waters, but is cosmopolitan. Captain Hancock collected it, also at Albemarle Island.
3. *Adocia simulans* (Johnston) 1842, p. 109. One specimen collected July 26 at Albemarle Island (Galápagos). This species was originally described from British waters, but is cosmopolitan. Captain Hancock collected it, also at Albemarle Island.

4. *Callyspongia vaginalis* (?) (Lamarck) 1814, p. 436. One small specimen collected July 21 at Clipperton Island (Galápagos). This species is nearly cosmopolitan. The specimen in question does not agree well with ordinary examples of *vaginalis*, but is approached by occasional specimens.

5. **MERRIAMIUM ROOSEVELTI**, n. sp.

Fig. 1

*Holotype*.—The sponge (U.S.N.M. no. 22614) was scraped from an old anchor chain at Elizabeth Bay, Albemarle Island, Galápagos, July 26, 1938 (sta. 20-38). It covers some other object, perhaps a barnacle, and is 1 or 2 mm. thick.

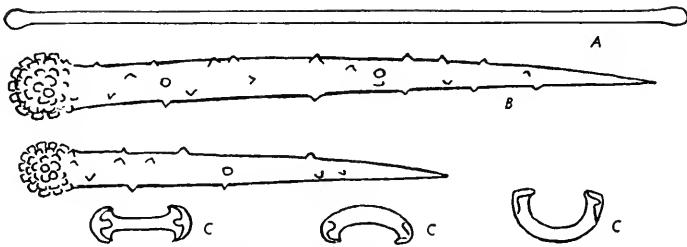

FIG. 1.—*Merriamium roosevelti*. A, dermal tylote; B, endosomal acanthostyle; C, arcuate isochelas. All  $\times 500$ .

*Description*.—Color nearly white, consistency soft. The entire organism is very fine-grained, with pores and oscules too small to be made out. The most remarkable items involved concern the skeleton; three sorts of spicules are present.

1. Ectosomal special spicules are tylotes 3 by 180 micra.
2. Endosomal spicules are abundant acanthostyles, heads with tubercles rather than spines, size 11 by 120 to 15 by 170 micra.
3. Microscleres are abundant arcuate isochelas with a semicircularly curved shaft and very small clads; the chord diameter varies from 21 to 24 micra.

*Remarks*.—A review of the genus *Merriamium* and a key to its several species is here presented to indicate better the relation of the new species to the members of the genus and also their relation to each other.

LIST OF PREVIOUSLY KNOWN SPECIES OF THE GENUS MERRIAMIUM

- a. *Merriamium atlanticum* was described as *Ectyodoryx a.* by Stephens, 1916, p. 238, from Ireland. The ectosomal spicules are

inequidended strongyles. The endosomal spicules vary from entirely spined to spined only on the heads. All the spicules are much larger than in *roosevelti*.

- b. Merriamium buchani* was described as *Lissodendoryx b.* by Topsent, 1913, p. 626, from the Antarctic. The ectosomal spicules are tylotes. The endosomal spicules are only rarely tuberculate, and all the spicules are much larger than in *roosevelti*.
- c. Merriamium certum* was described as *Dendoryx c.* by Topsent, 1892, p. 99, from the North Atlantic. The ectosomal spicules are hastate tornotes. The endosomal spicules are acanthostyles (not tylote) and both sorts are much larger than in *roosevelti*. The microscleres are two sizes of arcuate isochelas, very different in shape from those of *roosevelti*.
- d. Merriamium clavigerum* was described as *Esperella c.* by Levinson, 1886, p. 360, from the Arctic. The ectosomal spicules are oxeas nearly three times as large as the ectosomal tylotes of *roosevelti*. The other spicules are more nearly like those of *roosevelti* than is true of most species in the genus, but differ in many little details of shape.
- e. Merriamium kymum* was described as *Lissodendoryx k.* by de Laubenfels, 1930, p. 27, from California. Both the ectosomal spicules and the microscleres are somewhat like those of *roosevelti*, but the endosomal spicules are about twice as thick and more than twice as long, and are mostly smooth; only an occasional one has a few scattered spines.
- f. Merriamium lindgreni* was described as *Dendoryx mollis* by Lindgren, 1897, p. 482, and given the new name *lindgreni* by de Laubenfels, 1936, p. 83, because there was already another *Dendoryx mollis*. It is an East Indian species. The ectosomal spicules are much like those of *roosevelti*, but the endosomal spicules are nearly twice as long, but not thicker, and lack the tylote modification. The microscleres are much larger and of a different shape than those of *roosevelti*.
- g. Merriamium lobosum* was described as *Lissodendoryx l.* by Lundbeck, 1905, p. 154, from the Arctic. All the spicules are much as in *M. lindgreni*, but the microscleres differ radically in shape from those of all others of the genus.
- h. Merriamium lundbecki* was described as *Lissodendoryx l.* by Topsent, 1913, p. 41, from the North Atlantic. The spicules are much like those of *M. clavigerum* (*d.*, above) but the endosomal

acanthostyles lack the tylote modification, and the microscleres are of two size ranges (60 micra and 23 micra).

- i. *Merriamium maculatum* was described as *Ectyodoryx m.* by Hentschel, 1911, p. 342, from West Australia. The ectosomal spicules are hastate tornotes with swollen ends. The endosomal spicules range from smooth styles 10 by 244 micra to acanthostyles 9 by 120 micra. The microscleres are commonplace.
- j. *Merriamium paupertas* was described as *Hymeniacidon p.* by Bow-erbank, 1866, p. 223, from Great Britain. Various authors report it from many locations in the North Atlantic. The ectosomal spicules are hastate tornotes. The endosomal spicules are acanthostyles ranging from shorter ones entirely spined to longer ones partly smooth. The microscleres are very much like those of *roosevelti*.
- k. *Merriamium sophium* was described as *Esperia s.* by Fristedt, 1887, p. 451, from the Arctic. The ectosomal spicules are strongyles, with ends sometimes microspined. The endosomal spicules are acanthostyles up to 578 micra long. The microscleres are, as in all this genus, arcuate isochelas.
- l. *Merriamium stylodermum* was described as *Lissodendoryx s.* by Hentschel, 1914, p. 101, from the Antarctic. The ectosomal spicules are hastate tornotes. The endosomal spicules are acanthostyles only partly spined, 15 by 284 micra. The microscleres have a very peculiar shape.
- m. *Merriamium tortugasensis* was so described by de Laubenfels, 1936, p. 83, simultaneously with the establishment of the genus, and is the genotype. It is from the West Indies. The ectosomal spicules are hastate tornotes. The endosomal spicules are thin acanthostyles, 5 by 180 micra. The microscleres are commonplace for the genus.

It may be noted that the generic characteristics include a principal (endosomal) skeleton of spiny monactinal spicules with a special dermal skeleton of smooth diactines, and microscleres that are exclusively arcuate isochelas.

#### KEY TO THE SPECIES OF THE GENUS MERRIAMIMUM

(The letter in parentheses following each species name corresponds to the lettering of the species in the review of the genus *Merriamium* just preceding.)

- I. The dermal diacts are hastate tornotes.
- A. The isochelas are typically arcuate.
1. The principal spicules are entirely spined.
    - a. The microscleres are of one size range.
      - i. Principal spicules about 5 micra thick.....*tortugasensis* (m)
      - ii. Principal spicules about 10 micra thick.....*maculatum* (i)
    - b. The microscleres are of two size ranges.....*lundbecki* (h)
  2. The principal spicules vary from shorter, entirely spined, to longer, only partially spined.....*paupertas* (j)
  3. The principal spicules have extremely few, blunt spines.....*buchani* (b)
- B. The isochelas have peculiar, long, thin, lateral alae.....*stylodermum* (l)
- II. The dermal diacts are oxeas.....*clavigerum* (d)
- III. The dermal diacts are strongyles.
- A. The principal spicules up to 950 micra, microscleres to 60 micra .....*atlanticum* (a)
- B. The principal spicules under 518 micra, microscleres under 34 micra .....*sophium* (k)
- IV. The dermal diacts are tylotes.
- A. The isochelas have peculiar, thin, sharp, lateral alae,
1. otherwise commonplace .....*certum* (c)
  2. also having a peculiarly keeled central shaft.....*lobosum* (g)
- B. The isochelas are typically arcuate.
1. The principal spicules are very thick (over 20 micra) and scarcely spined at all.....*kymum* (e)
  2. The principal spicules are entirely spined, and
    - a. about 8 micra thick; the chelas about 36 micra.....*lindgreni* (f)
    - b. about 15 micra thick; the chelas about 24 micra.....*roosevelti*
6. *Tedania nigrescens* (Schmidt) 1862, p. 74. Three specimens, collected at James Island (Galápagos), July 24, and one specimen collected in Mexico (Magdalena Bay), July 18. This species is nearly cosmopolitan. It was also collected by Captain Hancock on Albemarle Island (Galápagos), also in Mexico and Central America.
7. *Higginsia papillosa* Thiele 1905, p. 428. Four specimens, collected July 26 at Albemarle Island (Galápagos), two preserved dry. This species was originally described from Chile. Captain Hancock also collected it at Albemarle Island.
8. *Cliona cclata* Grant 1826, p. 79. Two specimens, collected July 26 at Albemarle Island (Galápagos), both preserved dry. This species was originally described from British waters, but is extremely cosmopolitan.
9. *Geodia paupera* Bowerbank 1873, p. 329. Three specimens, two collected at Albemarle Island (Galápagos), July 26, and one at James Island, July 24. This species was originally described from specimens of unknown locality. Captain Hancock also

- collected it from two islands of the Galápagos archipelago, namely Albemarle and Tower.
10. *Geodia gibberosa* Lamarck 1815, p. 333. One specimen, collected August 6 at Old Providence Island, Caribbean Sea. This species was originally described from the West Indian region, where it is widespread and abundant.
  11. *Tethya diploderma* Schmidt 1870, p. 52. One specimen, collected August 6 at Old Providence Island, Caribbean Sea. This species was originally described from the West Indies, where it is very widespread and common.
  12. *Leucosolenia canariensis* Miklucho-Maclay 1868, p. 230. One specimen collected at Old Providence Island, Caribbean Sea, August 6. This species was described originally from the Canary Islands, and recorded as being also West Indian by de Laubenfels in 1936. The specimen in the present collection has remarkably large triaxons, and remarkably few tetraxon spicules, but otherwise agrees rather well with the specimens previously described.
  13. *Oligoceras* (?) sp. Three small specimens of *Keratosa* were collected August 6 at Old Providence Island. No one of them is large enough for satisfactory identification.

## REFERENCES

- BOWERBANK, J. S.  
 1866 (pp. 223, 278). A monograph of the British Spongiadae, vol. 2, Ray Society, London, pp. 1-388.  
 1873 (p. 329). Contributions to a general history of the Spongiadae, pt. 4. Proc. Zool. Soc. London, pp. 3-25, 319-333, pls. 1-4.
- FRISTEDT, K.  
 1887 (p. 451). Sponges from the Atlantic and Arctic Oceans and the Behring Sea. Vega-Expeditionenens Vetensk. Iakttagelser (Nordenskiöld), vol. 4, pp. 401-471, pls. 22-31.
- GRANT, R. E.  
 1826 (p. 79). Notice of a new zoophyte (*Cliona celata* Gr.) from the Firth of Forth. Edinburgh New Phil. Journ., vol. 1, pp. 78-81.
- HENTSCHEL, E.  
 1911 (p. 342). Tetraxonida. 2 Teil: Fauna Südwest-Australiens, vol. 3, pp. 279-393.  
 1914 (p. 101). Monaxone Kiesel-schwämme und Horn-schwämme der Deutschen Sudpolar-Expedition 1901-1903, vol. 15, Zool. 7, pp. 37-418.
- JOHNSTON, G.  
 1842 (p. 109). A history of British sponges and lithophytes. Edinburgh, London, Dublin, xii + 264 pp., 25 pls.

LAMARCK, J. B. P. A. DE MONET

1814. (p. 436). Sur les Polypiers empâtés. Ann. Mus., vol. 20, pp. 370-386, 432-458.

1815 (p. 333). Suite des Polypiers empâtés (dont l'exposition commence au 20<sup>e</sup> vol. des Annales, p. 294). Mém. Mus., vol. 1. pp. 162-168, 331-340.

LAUBENFELS, M. W. DE

1930 (pp. 27, 28). The sponges of California. Stanford Univ. Bull., ser. 5, vol. 5, No. 98, pp. 24-29.

1936 (p. 83). A discussion of the sponge fauna of the Dry Tortugas in particular, and the West Indies in general, with material for the revision of the Families and Orders of the Porifera. Carnegie Inst. of Washington, Publ. No. 467, pp. 1-225, pls. 1-22.

LEVINSEN, G. M. R.

1886 (p. 360). Kara-Havets Svampe (Porifera). Dijnpha-Togtets zool. bot. Udbytte, pp. 341-382, pls. 29-31.

LINDGREN, N. G.

1897 (p. 482). Beitrag zur Kenntniss der Spongienfauna des Malaiischen Archipels und der Chinesischen Meere, Zool. Anz, vol. 20, pp. 480-487.

LUNDBECK, W.

1905 (p. 154). Porifera. Pt. 2: Desmacidonidae (pars.). Danish Ingolf-Exp., vol. 6, pp. 1-219, pls. 1-20.

MIKLUCHO-MACLAY, N.

1868 (p. 230). Beiträge zur Kenntniss der Spongien. 1: Ueber *Guancha blanca*, einen neuen Kalk-schwamm. Jen. Zeitschr., vol. 4, pp. 221-240, pls. 4-5.

SCHMIDT, O.

1862 (p. 74). Die Spongien des adriatischen Meeres. Leipzig, vii + 88 pp., 7 pls.

1870 (p. 52). Grundzüge einer Spongienfauna des atlantischen Gebietes. Leipzig, iv + 88 pp., 6 pls.

STEPHENS, JANE

1916 (p. 238). Preliminary notice of some Irish sponges, the Monaxonellida, Ann. and Mag. Nat. Hist., vol. 17, pp. 232-243.

THIELE, J.

1905 (p. 428). Die Kiesel- und Hornschwämme der Sammlung Plate. Zool. Jahrb. Suppl. 6, pp. 407-496, pls. 27-33.

TOPSENT, E.

1892 (p. 99). Contribution à l'Étude des Spongiaires de l'Atlantique Nord. Résultats des Campagnes scientifiques accomplies sur son Yacht par Albert I<sup>er</sup> Prince Souverain de Monaco. Fasc. 2, 165 pp., 11 pls.

1913 (p. 41). Spongiaires provenant des Campagnes scientifiques de la *Princesse Alice* dans les Mers du Nord. (1898-1899, 1906-1907). Result. Camp. Sci. Monaco, vol. 45, pp. 1-67, pls. 1-5.

1913 (p. 626). Spongiaires de l'Expedition Antarctique Nationale Ecos-saise. Trans. Roy. Soc. Edinburgh, vol. 49 (pt. 3, No. 9), pp. 579-643, pls. 1-6.





SMITHSONIAN MISCELLANEOUS COLLECTIONS  
VOLUME 98, NUMBER 16

A NEW DICROCOELIID TREMATODE  
COLLECTED ON THE PRESIDENTIAL  
CRUISE OF 1938

BY  
ALLEN McINTOSH  
U. S. Bureau of Animal Industry

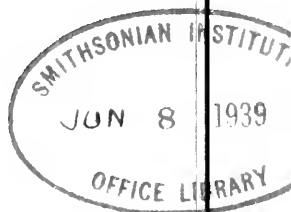

(PUBLICATION 3541)

CITY OF WASHINGTON  
PUBLISHED BY THE SMITHSONIAN INSTITUTION  
JUNE 8, 1939



SMITHSONIAN MISCELLANEOUS COLLECTIONS  
VOLUME 98, NUMBER 16

A NEW DICROCOELIID TREMATODE  
COLLECTED ON THE PRESIDENTIAL  
CRUISE OF 1938

BY  
ALLEN McINTOSH  
U. S. Bureau of Animal Industry



(PUBLICATION 5541)

CITY OF WASHINGTON  
PUBLISHED BY THE SMITHSONIAN INSTITUTION  
JUNE 8, 1939

The Lord Baltimore Press  
BALTIMORE, MD., U. S. A.

A NEW DICROCOELIID TREMATODE COLLECTED ON  
THE PRESIDENTIAL CRUISE  
OF 1938

By ALLEN McINTOSH  
*U. S. Bureau of Animal Industry*

Herein is described a new species of trematode belonging to the genus *Infidum* Travassos, 1916. This species is based on a single specimen obtained by John T. Lueker from the gall bladder of a "jubo" snake, *Orophis (Dromicus) hoodensis*. This snake was collected on the Galápagos Islands by members of the 1938 Presidential Cruise. After death of the snake in the National Zoological Park, where it had been exhibited, it was referred to Dr. Doris M. Cochran, Division of Herpetology, United States National Museum, for preserving and identification.

**INFIDUM LUCKERI, n. sp.**

*Description.*—Body oblong, 3.31 mm. long by 1.62 mm. wide; cuticula without spines but with what appear to be fine longitudinal ridges. Oral sucker subterminal  $412\mu$  in diameter; acetabulum pre-equatorial,  $412\mu$  by  $444\mu$ . Pharynx  $174\mu$  in diameter; oesophagus very short; intestinal crura ending at different levels in the third fourth of body. Excretory pore subterminal, dorsal. Testes oval, about  $200\mu$  by  $238\mu$ , with zones partially coinciding and fields separate, situated near level of posterior rim of acetabulum. Vasa efferentia uniting at base of cirrus sac dorsal to acetabulum; cirrus sac extending from near level of center of acetabulum to genital pore, the later located to left of median line at level of crural fork and ventral to outer margin of left crural branch. Ovary oval,  $174\mu$  by  $222\mu$ , median, its anterior margin at level of posterior rim of acetabulum. Laurer's canal and seminal receptacle present, but somewhat obscured by Mehlis' gland and vitelline reservoir which are located immediately posterior to ovary. Vitellaria extending from near level of anterior margin of acetabulum to slightly beyond middle of body. Uterus extending to near posterior end of body, with few coils slightly overlapping crura ventrally. Eggs light yellow,  $26\mu$  by  $16\mu$ .

*Habitat.*—Gall bladder of *Orophis (Dromicus) hoodensis* (U. S. Nat. Zool. Park no. 7485).

*Distribution.*—Hood Island, Galápagos Islands.

*Specimen.*—U.S.N.M. Helm. Coll. no. 43409 (type; fig. 1).

The genus to which the new species is assigned was proposed by Travassos (1916, Brazil-Med., vol. 30, pp. 257-258) for two dicrocoeliids, *Dicrocoelium infidum* Faria, 1910, and *Infidum similis* Travas-

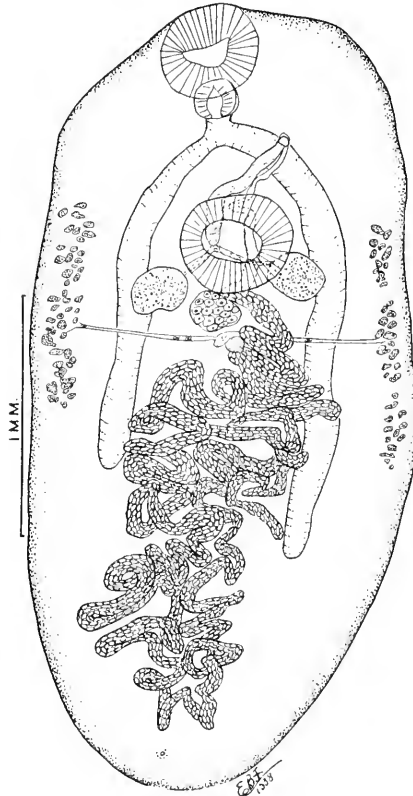

FIG. 1.—*Infidum luckeri*, new species.

so, 1916, from Brazilian snakes. *Infidum luckeri* is the third species to be assigned to the genus. The three species may be separated by the following key:

1. Vitellaria extending anteriorly to level of genital pore or beyond
  - I. infidum* (Faria)
  - Vitellaria extending anteriorly only as far as level of anterior margin of acetabulum ..... 2
2. Distance from tip of intestine to level of vitelline zone about equal to length of vitellaria ..... *I. similis* Travassos
- Distance from tip of intestine to level of vitelline zone much shorter than length of vitellaria ..... *I. luckeri*, n. sp.

SMITHSONIAN MISCELLANEOUS COLLECTIONS

VOLUME 98, NUMBER 17

POLYCLAD WORMS COLLECTED ON  
THE PRESIDENTIAL CRUISE  
OF 1938

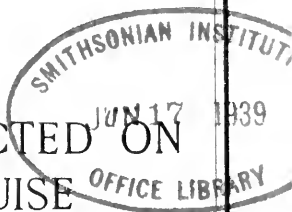

BY

LIBBIE H. HYMAN

American Museum of Natural History  
New York City



(PUBLICATION 3542)

CITY OF WASHINGTON  
PUBLISHED BY THE SMITHSONIAN INSTITUTION  
JUNE 17, 1939





SMITHSONIAN MISCELLANEOUS COLLECTIONS  
VOLUME 98, NUMBER 17

POLYCLAD WORMS COLLECTED ON  
THE PRESIDENTIAL CRUISE  
OF 1938

BY  
LIBBIE H. HYMAN  
American Museum of Natural History  
New York City



(PUBLICATION 3542)

CITY OF WASHINGTON  
PUBLISHED BY THE SMITHSONIAN INSTITUTION  
JUNE 17, 1939

The Lord Baltimore Press  
BALTIMORE, MD., U. S. A.

## POLYCLAD WORMS COLLECTED ON THE PRESIDENTIAL CRUISE OF 1938

By LIBBIE H. HYMAN

*American Museum of Natural History, New York City*

The material consisted of four vials of polyclads collected at various points along the shores of the Galápagos Islands and Old Providence and Clipperton Islands by Dr. Waldo L. Schmitt during the Presidential Cruise of 1938. Each vial contained a different species represented in three vials by a single specimen, in the fourth vial by two specimens. All of the worms were badly crumpled and folded and it was necessary to straighten them out forcibly before any work could be done on them. This has resulted in some distortion of parts and has produced folds and wrinkles in the body surface, but the material is adequate for the determination of the necessary points of anatomy. All of the specimens were stained as whole mounts with dilute acidified borax carmine and, after they were studied and drawn, the sexual region was removed in the case of three species and cut into sagittal serial sections. The study of the material has shown that it comprises two species of *Notoplana*, one of *Euplana*, and one of *Prosthiostomum*, all of which appear to be undescribed forms.

### NOTOPLANA INSULARIS, n. sp.

Figs. 1-3

*Description.*—The single specimen, somewhat contracted and folded (fig. 1), is 9 mm. long and 3 mm. wide at the widest part, obviously much longer in life, of elongated oblong shape, tapering somewhat posteriorly. Color not determinable. Pharynx small with a few folds, embraced by the uteri which come to a point anteriorly behind the brain. Eyes (fig. 2) in paired elongated bands, tentacular clusters thus not separated from cerebral groups; tentacular groups evident as rounded group in each band at about the level of the middle of the brain. Eyes unusual in that cerebral eyes are of the same size as tentacular eyes. Posterior half of specimen made into serial sections. Copulatory apparatus (fig. 3) typical of the genus. Seminal vesicle oval, with thick muscular wall of fibers parallel to the surface contour. Ejaculatory duct curves backward and after a short course

enters the oval prostate vesicle, which is smaller than the seminal vesicle. This has a moderately thick muscular wall of fibers parallel to the surface contour, penetrated by the ducts of the extracapsular prostate glands. Ejaculatory duct projects into prostate vesicle for about three-fourths the length of the latter. No penis papilla. A relatively short stylet springs directly from the prostate vesicle; it lies in a moderately long tubular male antrum which curves gracefully ventrally and posteriorly to the male genital pore. Male antrum with a muscular wall of inner longitudinal and outer circular fibers. Female pore shortly behind male pore; canal leading in from surface probably artificial caused by straightening of the specimen. Vagina of moderate width with coating of circular muscle fibers; curves posteriorly and widens where it receives the uteri; beyond this, wide stalk of Lang's vesicle curves down, then posteriorly, and opens into the very long large Lang's vesicle.

*Remarks.*—*Notoplana insularis* does not closely resemble any of the known species from adjacent islands of the Caribbean and West Indies, but seems more nearly related to *N. stylifera* from Juan Fernandez, from which, however, it differs in several details, which will be apparent on comparison of my figures with those of Bock.

*Differential diagnosis.*—Tentacular and cerebral eyes in one band, cerebral eyes of same size as tentacular eyes, seminal vesicle larger than prostate vesicle, no penis papilla or penis sheath, penis stylet short, male antrum tubular, vagina widened at entrance of uteri.

*Locality.*—Shores, Old Providence Island. Collected by Dr. Waldo L. Schmitt, August 6, 1938.

*Holotype.*—Anterior half as whole mount; posterior half as sagittal serial sections, U.S.N.M. no. 20423.

#### NOTOPLANA CARIBBEANA, n. sp.

Figs. 4-8

*Description.*—One large specimen, 33 mm. long, 13 mm. wide at widest part, of elongated wedge form, widest anteriorly, tapering gradually to obtuse posterior end (fig. 4). Color not determinable. Eyes in paired bands in which the tentacular clusters are included (fig. 5). Some indications of tentacles in center of tentacular eye clusters; tentacular eyes obviously larger than cerebral eyes; cerebral eyes small, forming elongated group anterior to tentacular group and few scattered eyes behind tentacular group. Pharynx long, very narrow, with many small folds, embraced by uteri which come to a point in front of pharynx (fig. 4). Sexual region removed and cut into

sagittal serial sections. Male and female pores considerably separated, forming large oval openings. Crescentic seminal vesicle immediately behind posterior end of pharynx has very thin wall of muscle fibers paralleling its external contour. Seminal vesicle opens directly into large spherical chambered prostatic vesicle without the intervention of a duct; ejaculatory duct projects only a short distance into prostatic vesicle (fig. 6). Small penis papilla at beginning of male canal leading away from prostate vesicle. This canal, similar to penis pocket of other *Notoplanas*, is remarkably long and slender; runs backward above excessively muscular mass surrounding the male antrum and opens into posterodorsal angle of this antrum. Male antrum large with long anterior extension and lined by a tall epithelium filled with granules of glandular nature; male antrum surrounded by thick powerful muscle fibers running mostly lengthwise filling all space between antrum, prostate vesicle, and penis pocket. Posterior wall of antrum also muscular. Antrum opens below by large oval male genital pore.

Large oval female pore considerably behind male pore (relative positions shown in fig. 4). Pore opens into wide funnellike female antrum (fig. 7) with very folded walls; this appearance may be due to the straightening of the specimen. Tall lining epithelium of female antrum has glandular appearance. Vagina proceeds anteriorly from female antrum, makes sharp posterior bend, and some distance beyond the bend receives the uteri. Beyond uteri long slender stalk of Lang's vesicle runs backward and downward and opens into elongated oval Lang's vesicle. Vagina and stalk lined by ciliated epithelium, outside of which is a fibrous coat which does not appear to be muscular. Numerous cement glands open into vagina and beginning of vesicle stalk. Lang's vesicle lined by very tall epithelium, the distal two-thirds of which is filled with eosinophilous spherules (fig. 8). These suggest an eosinophilous secretion, but it is more probable that they are digesting material. Lang's vesicle probably serves to digest excess sex cells as well as for a seminal receptacle.

*Remarks.*—This species undeniably bears a very great resemblance in size, shape, and the details of the copulatory apparatus to *Notoplana binoculata* (Verrill) 1901 (syn. *Notoplana bahamensis* Bock 1913) of which Bock has given a good description, supplemented by some remarks in a recent paper of mine (Hyman, 1939). The similarity of *N. caribbcana* to *N. binoculata* is not surprising, in view of the proximity of Old Providence Island to the Bahamas, and there still remains a little doubt in my mind that I am justified in making a distinct species of *N. caribbcana*. The following differences may be

noticed between the two species. In *N. caribbeana* the cerebral eyes are much smaller than the tentacular eyes and on the same level, whereas in *N. binocularata* they are of nearly the same size as the tentacular eyes and so deeply buried that they were overlooked altogether by Verrill (whence the name *binocularata*). The seminal vesicle of *N. caribbeana* is much larger and thinner walled than that of *N. binocularata*, its male canal is longer and the male antrum is of different shape and lacks the two hillocks found in *N. binocularata* to which I have called attention. The female apparatus of the two species is very similar, but in *N. caribbeana* the vagina and stalk of Lang's vesicle appear to be longer than in *N. binocularata* (although these differences may depend simply on the size of the specimen) and the cement glands extend farther along the female apparatus than in *N. binocularata*. These differences seem to justify the separation of the forms as distinct species. Bock has placed *N. binocularata* in his group B, typified by *N. atomata*, but admits that it is not closely related to the members of this group. I suggest that *N. binocularata* and *N. caribbeana* be considered to constitute a separate group of the large genus *Notoplana*, characterized by the long male canal and the large extremely muscular male antrum.

*Differential diagnosis.*—*N. caribbeana* differs from other *Notoplanas* except *N. binocularata* in the long slender male canal, large male antrum with an anterior extension, and excessive muscularity of the anterior wall of the male antrum, whose muscle fibers fill all the space between antrum and seminal vesicle. Differences from *N. binocularata* are listed above.

*Locality.*—Shores of Old Providence Island. Collected by Dr. Waldo L. Schmitt, August 1, 1938.

*Holotype.*—Whole mount with sexual region removed; set of sagittal sections of sexual region, U.S.N.M. no. 20424.

#### EUPLANA CLIPPERTONI, n. sp.

Figs. 9-12

*Description.*—Two specimens, larger 17 mm. long, 7 mm. wide across widest part, not quite fully mature sexually, elongated, widest at about the level of the brain, tapering posteriorly, much folded and contracted, evidently much longer and more slender in life (fig. 9). Smaller specimen very young, 6.5 mm. in length, obovate, with no trace of sex organs. Color not determinable. With evident tentacular groups of eyes, consisting of 3 large eyes and 4-6 smaller ones (fig. 10). Cerebral eyes loosely arranged, scattered, radiating in a

linear arrangement along the principal nerve trunks (fig. 10). Of the cerebral eyes, there are two large ones close to the cerebral mass of granules characteristic of many Acotylea, and some large ones in a row along the bases of the main anterolateral nerve trunks (fig. 10). The smaller eyes are peripheral to the large ones, radiating along the nerve trunks. Small specimen (fig. 11) has same number and arrangement of large eyes as the larger specimen, but the smaller eyes have not yet appeared. Pharynx relatively small with small lateral folds. Sexual region of larger worm removed and sectioned. Conclusion from study of whole animal that sexual maturity had not quite been attained confirmed by study of sections, but essential parts appear to be present. Sexual apparatus close behind pharynx, far removed from posterior end of body. Sexual pores some distance apart (fig. 9). Male copulatory apparatus (fig. 12) typical of the genus, i. e., the male canal is not definitely divisible into seminal vesicle and prostatic vesicle, and may be considered to consist entirely of the seminal vesicle. Vasa deferentia enter separately the lateral angles of the seminal vesicle; seminal vesicle then turns dorsally, then bends posteriorly and extends as slender tube to penis papilla. Seminal vesicle has narrow lumen and thick muscular wall composed chiefly of circular fibers. No prostatic glands seen, probably because of immaturity of the specimen. Penis papilla small, rounded, armed with a short stylet in process of being secreted. Penis papilla lies in short penis pocket which forms a penis sheath where it joins the male antrum. Latter moderately large cavity, of moderate length. Female apparatus (fig. 12) has large genital pore, long muscular vagina bent into an S-shape, receiving cement glands along its course. Following entrance of uteri, female canal continues as a small Lang's vesicle, which may not yet be fully formed.

*Remarks.*—In an article on Atlantic coast polyclads (Hyman, 1939 b), I have shown that "*Prosthiostomum*" *gracile* Girard 1850<sup>1</sup> is not a *Prosthiostomum* at all, but fits into *Discoplana* Bock 1913. However, since Girard in 1893 himself removed this species from *Prosthiostomum* and created for it a new genus *Euplana*, *Discoplana* must become a synonym of *Euplana*. The copulatory apparatus of

<sup>1</sup>In a recent publication Pearse (1938) has grossly misidentified *Euplana gracilis* (Girard) considering it a new species, type of a new genus, *Conjuguterus*. *Conjuguterus* becomes a synonym of *Euplana* and *C. parvus* a synonym of *Euplana gracilis*. Pearse's account of the male system of this species is also erroneous. These corrections are based on an examination of the type specimen of *C. parvus* and a number of other specimens labelled by Pearse with this name.

*Euplana* (= *Discoplana*) is very similar to that of the genus *Stylochoplana* and in fact it is difficult to distinguish between these two genera. The sole difference is that in *Euplana* there is no distinct prostatic vesicle, whereas one exists in *Stylochoplana*. *E. clippertoni* certainly resembles *Stylochoplana* in general external appearance, but has no definite prostatic vesicle and hence seems to fit better into *Euplana*. It differs from other known species of *Euplana* (= *Discoplana*) in the presence of a penis stylet. *Euplana gracilis* (Girard) is the most simplified member of the genus, having no penis papilla, stylet, or penis sheath.

*Differential diagnosis*.—Loosely arranged radiating cerebral eyes, small penis papilla, penis pocket, penis sheath and short stylet present, long muscular vagina with S-bend, small Lang's vesicle, genital pores well separated.

*Locality*.—Clipperton Island, under rocks to south of landing place. Collected by Dr. Waldo L. Schmitt, July 21, 1938.

*Holotype*.—Whole mount with sex region removed; set of sections of sex region, U.S.N.M. no. 20425. Young specimen on same slide with holotype.

#### PROSTHIOSTOMUM PARVICELIS, n. sp.

Figs. 13-15

*Description*.—One specimen, 6 mm. long, of usual slender shape typical of the genus, fully mature, bent in sexual region, part of anterior margin missing (fig. 14). Color not determinable. Eyes as usual in the genus, comprising paired cerebral groups, and band of eyes along anterior margin (fig. 13). Cerebral eyes consist of an irregular curved row of 7 eyes on one side, 8 on the other, with a single isolated eye lateral to the anterior end of the rows, on each side. Marginal row of eyes unfortunately imperfect because of missing anterior margin but obviously few in number compared to most other species of the genus, of about 2 rows in central part of band, thinning out around the sides to a few widely spaced eyes in a single row. Pharynx typical of the genus (fig. 14). Because of bend in body making good sagittal sections impossible, sexual apparatus was not sectioned. Because of eversion of the male apparatus, most of this apparatus can be seen in the whole mount. Male apparatus completely everted as in copulation (result of fixation?) (fig. 15). Inside the large cylindrical everted structure can be seen the oval seminal vesicle with thick muscular wall and Indian-club shaped lumen, the 2 spherical thick-walled accessory vesicles (of unknown function), and the



sinuous ejaculatory duct. The ducts of the accessory vesicles were not seen. At the distal end of the evert is the penis sheath; through its lumen extends the curved stylet typical of the genus, protruding from the penis end for about one-third of its length. The sperm form a club-shaped sharply defined mass in the lumen of the seminal vesicle and from this mass a stream of sperm can be followed along the ejaculatory duct and stylet and out of the tip of the stylet. The mode of entrance of the vasa deferentia into the seminal vesicle is shown in the figure.

Not much can be made out of the female apparatus in the whole mount; genital pore appears to lead into a cement pouch which receives the encircling cement glands (fig. 15).

The eversion of the male apparatus in this specimen is of great interest. It is undoubtedly normal since the same eversion was seen in a Bermuda *Prosthiosomum*, *P. cyclops* (Verrill) where, however, the specimen, through long preservation, was so dark and opaque that nothing could be discerned in the protruded apparatus. This Galápagos specimen indicates that in *Prosthiosomum* the entire male apparatus everts in copulation. This means that the male antrum must turn inside out, so that its lining becomes the surface epithelium of the evert, and the whole male copulatory complex, including the seminal vesicle and the 2 accessory vesicles, becomes pulled into the evert. It is further seen from figure 15 that the so-called penis sheath actually serves as penis papilla while the penis papilla remains inside and appears to function merely to anchor the stylet. One begins to wonder if these structures have not been misnamed and if the penis sheath should not be regarded as the penis papilla, and the projection at present considered the penis papilla should not receive some other name. Of course, many polyclads do not have a penis sheath. Whether it occurs only in those species with a stylet deserves investigation.

*Remarks.*—The species of the genus *Prosthiosomum* resemble each other so closely in external characters and details of the copulatory complex that separation into species is often difficult. As pointed out by Bock (1913) one must depend chiefly on the coloration and the eye arrangement. Some differences also appear to exist as regards the length and shape of the male antrum, shape of the seminal vesicle, and points of entrance of the vasa deferentia into the seminal vesicle. On the whole it is not advisable to omit the study of serial sections in determining the species of this genus. In the Galápagos specimen, the damage to the marginal set of eyes, the lack of data on the coloration in life, and the eversion of the male apparatus, preventing com-

parisons with other species where the male apparatus in known only in the resting condition, have increased the difficulties of deciding whether one is here dealing with a new species or not. The great resemblance, even almost the identity, of the eye arrangement of the present species with that of the common Mediterranean *Prosthiostomum*, *P. siphunculus* (Delle Chiaje) 1828, fully described by Lang, 1884, will not have escaped the notice of students of polyclads. On the other hand, it seems highly improbable that the same species would be found in two such widely separated localities as the Mediterranean and the Galápagos Islands. It further appears that *P. siphunculus* is very much larger than *P. parvicelis*. According to Lang, 1884, the former may reach a length of 30 mm. and the majority of the sexual individuals range from 12-18 mm. The specimen of *P. parvicelis* is already fully mature at a length which could not have been more than 8 mm. in the extended condition. The principal difference, however, between the two species, concerns the shape of the seminal vesicle and the points of entrance of the vasa deferentia. Lang, 1884, plate 30, figure 20, shows the seminal vesicle of *P. siphunculus* as curved, with a simple fusiform lumen and muscular wall of uniform width; the vasa enter at its proximal end. In *P. parvicelis* the wall of the seminal vesicle is very thick proximally and thins out distally, the lumen is of peculiar shape (fig. 15), and the vasa deferentia enter the sides and then turn proximally to join the beginning of the lumen. The shape of the cement pouch appears also to differ in the two forms. On these grounds I with some hesitation consider the Galápagos species distinct from the Mediterranean one.

*Differential diagnosis.*—Eye arrangement as in *P. siphunculus*; smaller than this species; seminal vesicle with thicker wall and small lumen proximally, thin wall and larger lumen distally, receiving the vasa deferentia into its sides.

*Locality.*—Sullivan Bay, James Island, Galápagos Islands, shore collecting. Collected by Dr. Waldo L. Schmitt, July 24, 1938.

*Holotype.*—One whole mount, U.S.N.M. no. 20426.

#### REFERENCES

BOCK, SIXTEN

1913. Studien über Polycladen. Zool. Bidrag, vol. 2, pp. 1-343.

1923. Polycladen aus Juan Fernandez. The Natural History of Juan Fernandez and Easter Island, vol. 3, pp. 341-372.

GIRARD, CH.

1893. Recherches sur les Planaires et les Nemertiens de l'Amerique du Nord. Ann. Sci. Nat., vol. 15, No. 7, pp. 145-310.

HYMAN, L. H.

1939a. Acoel and Polyclad Turbellaria from Bermuda and the Sargassum. In press.

1939b. Some Polyclads from the New England coast, especially from the Woods Hole region. *Biol. Bull.*, vol. 76, pp. 127-152.

LANG, A.

1884. Die Polycladen (Seeplanarien) des Golfes von Neapel und der angrenzenden Meeresabschnitte. *Fauna und Flora des Golfes von Neapel*, Monog. 11.

PEARSE, A. S.

1938. Polyclads of the east coast of North America. *Proc. U. S. Nat. Mus.*, vol. 86, pp. 67-98.

VERRILL, A. E.

1901. Addition to the fauna of the Bermudas from the Yale Expedition of 1901, with notes of other species. *Trans. Connecticut Acad. Sci.*, vol. 11, pp. 15-62.

#### EXPLANATION OF NUMBERING OF TEXT-FIGURES

1, cerebral eyes; 2, tentacular eyes; 3, cerebral granule mass; 4, uterus; 5, pharynx; 6, seminal vesicle; 7, prostate vesicle; 8, stylet; 9, male genital pore; 10, female genital pore; 11, Lang's vesicle; 12, stalk of Lang's vesicle; 13, vagina; 14, entrance of uteri into vagina; 15, female antrum; 16, male antrum; 17, ejaculatory duct; 18, extracapsular prostate glands; 19, vasa deferentia; 20, cement glands; 21, penis papilla; 22, muscular wall of male antrum; 23, penis pocket; 24, penis sheath; 25, cement pouch; 26, accessory vesicles; 27, everted male organ; 28, sucker; 29, marginal glands; 30, sperm mass in seminal vesicle; 31, opening of prostate glands into penis pocket.

Whole mounts and figures of eyes drawn with the aid of the camera lucida; others free-hand.

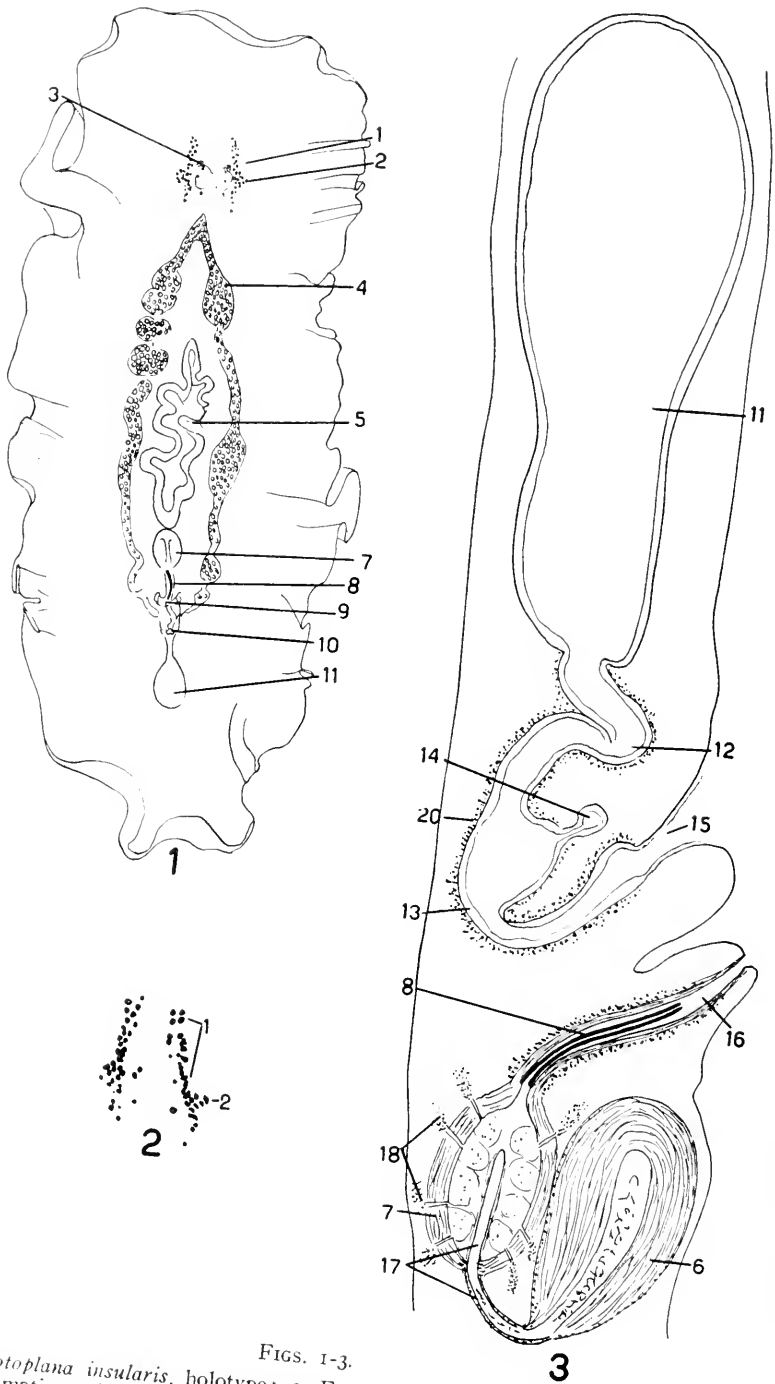

FIGS. 1-3.  
 1, *Notoplana insularis*, holotype; 2, Eyes of *Notoplana insularis*; 3, Semi-diagrammatic sagittal view of the copulatory apparatus of *Notoplana insularis*, based on sagittal sections of the sexual region of the holotype.

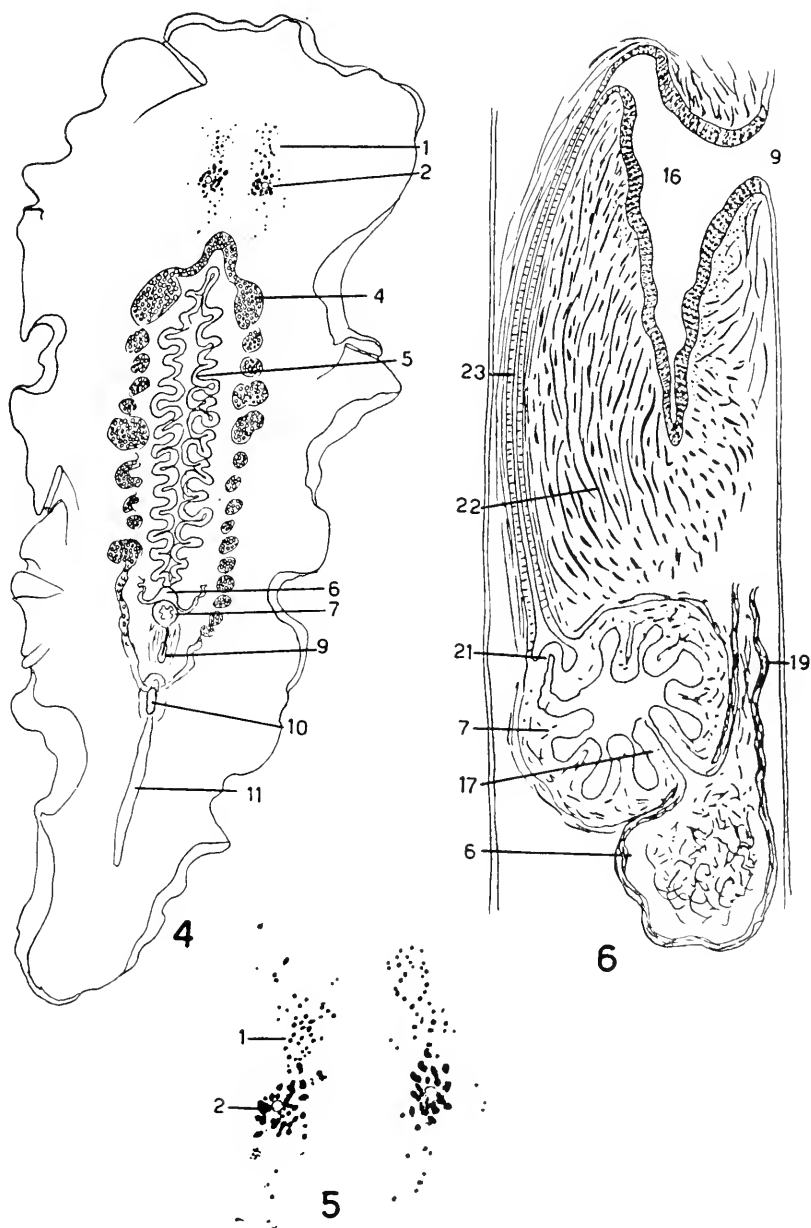

FIGS. 4-6.

4, *Notoplana caribbeana*, holotype; 5, Eyes of *Notoplana caribbeana*; 6, Semi-diagrammatic sagittal view of the male copulatory apparatus of *Notoplana caribbeana*, based on sagittal sections of the sexual region of the holotype.

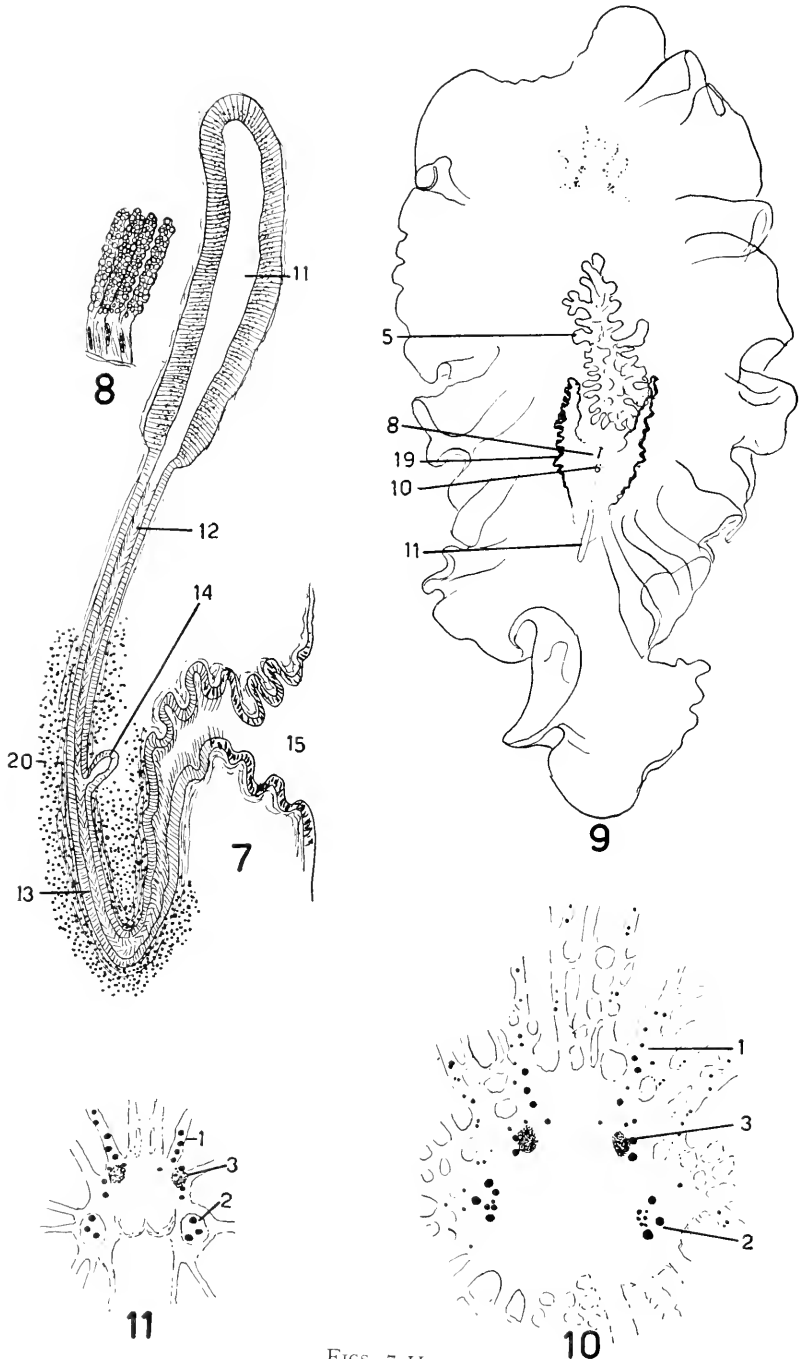

FIGS. 7-11.

7. Sagittal view of the female apparatus of *Notoplana caribbeana*, from same set of sections as fig. 6; 8, A few cells from the lining vesicle of *Notoplana caribbeana*, showing eosinophilic spherules; 9, *Euplana clippertoni*, holotype; 10, Eyes of *Euplana clippertoni*, holotype; 11, Eyes of a young specimen of *Euplana clippertoni*.

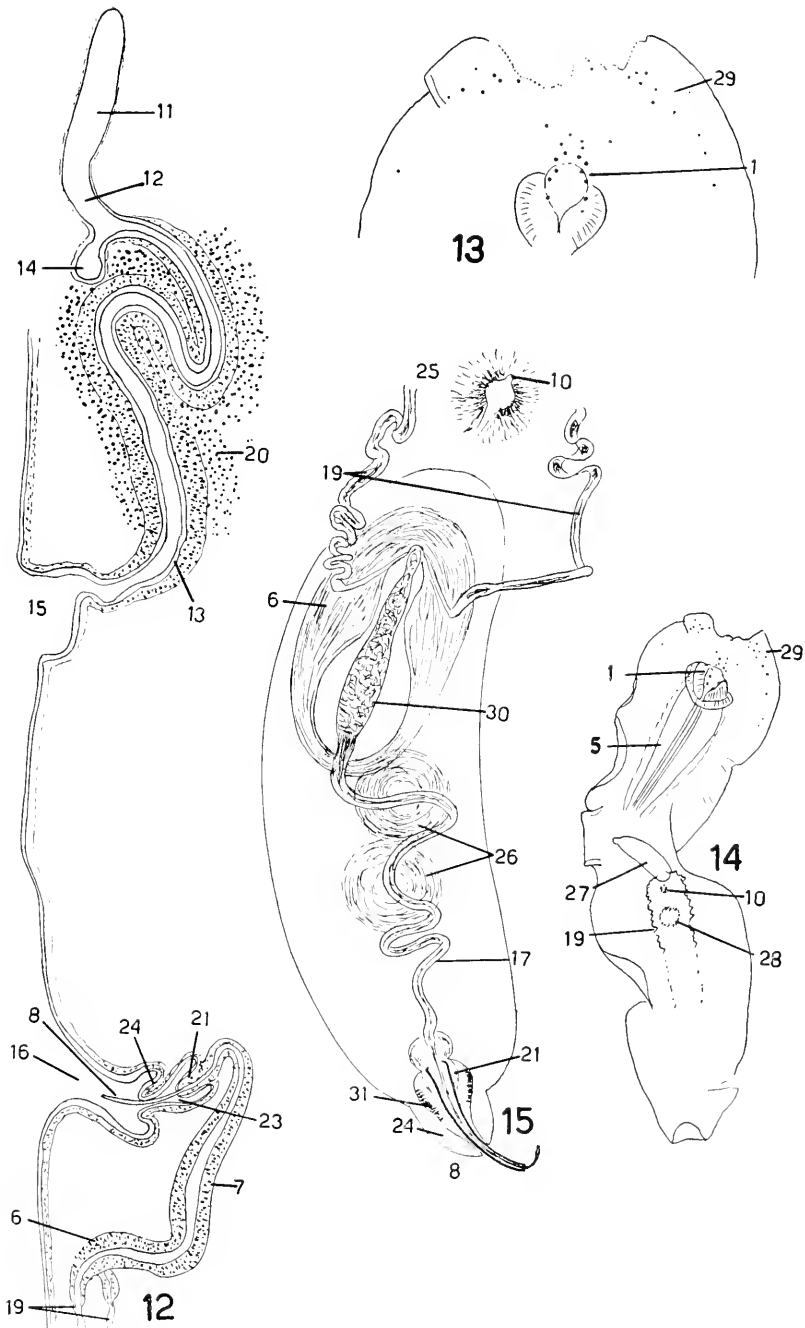

FIGS. 12-15.

12, Semidiagrammatic sagittal view of the copulatory complex of *Euplana clippertoni*, based on sagittal serial sections of the sexual region of the holotype; 13, Eyes of *Prosthiostomum parvicelis*, holotype; 14, *Prosthiostomum parvicelis*, holotype; 15, Everted male copulatory organ of *Prosthiostomum parvicelis* containing the male apparatus.





SMITHSONIAN MISCELLANEOUS COLLECTIONS  
VOLUME 98, NUMBER 18

NOTES ON HILLERS' PHOTOGRAPHS OF  
THE PAIUTE AND UTE INDIANS TAKEN  
ON THE POWELL EXPEDITION  
OF 1873

(WITH 31 PLATES)

BY  
JULIAN H. STEWARD  
Bureau of American Ethnology  
Smithsonian Institution

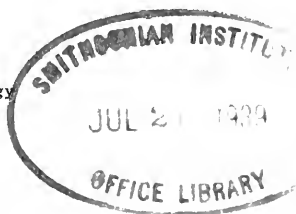

(PUBLICATION 3543)

CITY OF WASHINGTON  
PUBLISHED BY THE SMITHSONIAN INSTITUTION  
JULY 21, 1939



SMITHSONIAN MISCELLANEOUS COLLECTIONS

VOLUME 98, NUMBER 18

NOTES ON HILLERS' PHOTOGRAPHS OF  
THE PAIUTE AND UTE INDIANS TAKEN  
ON THE POWELL EXPEDITION  
OF 1873

(WITH 31 PLATES)

BY

JULIAN H. STEWARD

Bureau of American Ethnology  
Smithsonian Institution



(PUBLICATION 3543)

CITY OF WASHINGTON  
PUBLISHED BY THE SMITHSONIAN INSTITUTION  
JULY 21, 1939

The Lord Baltimore Press  
BALTIMORE, MD., U. S. A.

NOTES ON HILLERS' PHOTOGRAPHS OF THE PAIUTE  
AND UTE INDIANS TAKEN ON THE POWELL  
EXPEDITION OF 1873

BY JULIAN H. STEWARD

*Bureau of American Ethnology, Smithsonian Institution*

(WITH 31 PLATES)

INTRODUCTION

When, in 1869, Maj. John W. Powell made his first exploration of the Colorado River, he encountered Ute and Southern Paiute Indians in the territory that is now Utah and northern Arizona. Fascinated at finding them nearly untouched by civilization, he developed a deep interest in ethnology which led to extensive field studies and even ultimately to the founding of the Bureau of American Ethnology. During explorations, he took every opportunity to study their language, customs, and mythology, to collect specimens of their utensils, dress, and handicraft, and to procure photographs.

Few explorers in the United States have had a comparable opportunity to study and photograph Indians so nearly in their aboriginal state. The Ute, to be sure, had probably experienced something of a cultural revolution when they acquired the horse from the Spaniards in the Southwest long before the first white man visited their country. They were already hunters and warriors, in many respects resembling the tribes of the Great Plains, when Escalante passed through Utah in 1776. After the 1820's, when fur trappers began to penetrate their territory, the Ute acquired a few guns and other trade objects, but were little affected by their casual contacts with the white men. The Southern Paiute, meanwhile, living in the more arid country to the south and west, remained, without horses or guns, entirely in their aboriginal state. In 1847 the Mormon pioneers arrived at Great Salt Lake and within a few years planted settlements throughout much of the desert. The Ute resisted this settlement, especially in western Utah, and warfare began, reaching a climax about 1865. The Ute were subdued, however, by 1870, and many of them moved to the reservation which had been founded in the territory of one of their bands, the Uintah Ute, in northeastern Utah. There were thus

Ute from many localities in this region when Powell first passed through it in 1869. They had, however, been in close contact with the white man for only 20 years and had not lost their native customs.

Mormon settlement of Southern Paiute territory affected native life in varying degrees. In the vicinity of St. George and Kanab, in southern Utah, the Paiute were too poor and unorganized to offer effective resistance to settlement. They lingered in their original habitat in the vicinity of the newly founded Mormon villages and, as the destruction of their native foods by cattle, sheep, and farming made life difficult, they gradually attached themselves to these communities. The early 1870's, however, found their native culture still little affected by these contacts. Most isolated of all were the Paiute on the Kaibab plateau north of the Grand Canyon in Arizona. In 1869 many of them had scarcely seen a white man and, beyond a few objects which they traded or stole from the white man, they were quite untouched by civilization. When first visiting this group in September, 1869, Powell<sup>1</sup> wrote, "Altogether, these Indians are more nearly in their primitive condition than any others on the continent with whom I am acquainted. They have never received anything from the Government, and are too poor to tempt the trader, and their country is so nearly inaccessible that the white man never visits them." Fortunately, most of Powell's notes, collections, and photographs come from these people.

None of the results of Powell's ethnographic work have been published in systematic form. Brief remarks on language, customs, and mythology are found in many of his writings, and considerable remains scattered through unpublished manuscripts. The latter contain much that is of value, but the task of culling the ethnographic data from other miscellaneous material, of ascertaining the identity of Indians mentioned, and of eliminating repetitious notes is formidable. Powell's extraordinarily fine collection of Ute and Paiute specimens in the United States National Museum is largely unknown to the scientific world. But properly to describe and illustrate it would require enormous work and expense and would be handicapped by the inadequate data accompanying it. Like most collections made during that period, a catalog entry like "Ute" or "Pah Ute" was deemed sufficient to indicate the source of a specimen.

The most valuable ethnographic result of Powell's explorations are the photographs. On his second descent of the Colorado River in

---

<sup>1</sup> Powell, John W., *Exploration of the Colorado River of the West and its tributaries*, p. 126. Washington, 1875.

1871, he was accompanied by John K. Hillers. Hillers began as a general assistant but quickly mastered photography and remained with Powell during his explorations of the next few years making photographs of all types of subjects. His pictures are on glass negatives, each having two exposures 4 by 5 inches suitable for stereopticons. In spite of the cumbersome equipment and the difficulties of preparing and developing negatives in the field, most of these pictures are every bit as good as modern professional photography and put to shame the efforts of most ethnologists.

Unlike the collections of specimens and ethnographic notes, the photographs are carefully cataloged as to locality, leaving no doubt about which Indian groups are represented. The catalog does not indicate, however, precisely when or under what circumstances the pictures were taken. The date on all is 1873, but it is entirely possible that many were taken earlier, perhaps starting with the Colorado River trip of 1871. Presumably they were taken during the summer when the type of house, clothing, and other features of native life would have been somewhat adapted to the warm weather and to the nomadic life necessary when gathering seeds.

The present collection includes all of the Hillers photographs that have ethnographic value. A number of these were reproduced as steel engravings in some of the publications by Powell, Mason, and other persons, but are included here not only for the sake of completeness but to bring out detail not obtainable in the engravings and to call attention to features of ethnographic interest. A few photographs have been eliminated either because of the poor quality of the negatives or because they are virtually duplicates of those included.

It had been hoped that a description of the museum specimens, which include many objects similar to those shown in the photographs, might accompany these pictures. In view, however, of the dubious provenience of many of the specimens and of the magnitude of the task of describing them, the museum study must be postponed.

Identification of the objects illustrated in the photographs may be made with reasonable certainty. Until very recent years, the Ute and Southern Paiute and the very similar Shoshoni and Northern Paiute, all occupying the deserts between the Rocky Mountains and California, had been virtually ignored by ethnologists. Although detailed monographs by several field workers are now in course of preparation for publication, Lowie's pioneering study of these tribes<sup>2</sup>

<sup>2</sup> Lowie, Robert H., *Notes on Shoshonean ethnography*. Amer. Mus. Nat. Hist., Anthropol. Papers, 20, pt. 3, pp. 187-314, 1924.

remains the outstanding source on the Ute and Southern Paiute. It is possible, however, by using Lowie's monograph together with monographs on tribes farther west, shorter accounts of these tribes by explorers and ethnologists,<sup>3</sup> and the writer's own experience in the area, to interpret most of the photographs in terms of their cultural significance and to add some comparative notes.

Before the settlement of the west, a great difference existed between the Ute and Southern Paiute, the two main groups represented in these photographs. The former were essentially horsemen, bison hunters, and warriors. For many years they had been traveling east to hunt bison in the Great Plains. Warfare with tribes in that area had given them a militaristic spirit. Cultural contacts had introduced many conspicuous Plains traits, such as tipis, use of rawhide, horse regalia, war equipment, and many others.

The Southern Paiute, more isolated in their deserts and lacking horses, resembled the Western Shoshoni and Northern Paiute, who lived in the Great Basin of Nevada and adjoining parts of California, Oregon, and Idaho. They relied mainly upon wild seeds and roots which they collected by means of a highly developed basketry complex. Large-game hunting was of secondary importance, though the great number of buckskin garments shown in the photographs suggests that it was not so unimportant as often believed. The Paiute's general poverty and the seminomadic existence required during the great part of the year by their simple hunting and gathering economy limited their material possessions. The photographs show them, probably most often at their temporary summer encampments, with their meager equipment.

Caution, however, is necessary in interpreting the pictures. Not only are many of the Indians obviously posed in artificial stances, but art seems often to have outweighed realism in the selection of objects represented. Thus, a woman in semidress may indicate Powell's and Hillers' idea of photographic art rather than actual use of garments. Poses with bows, baskets, and other objects may also misrepresent their actual use.

#### HABITATIONS

When Indian informants describe customs abandoned one or two generations ago, they are likely to remember only salient features and thus give the impression that native practises were more stand-

---

<sup>3</sup> The main sources to date are listed in the writer's study of the Shoshoni, Basin-Plateau aboriginal socio-political groups, *Bur. Amer. Ethnol. Bull.* 120, 1938.



ardized than was actually the case. These photographs, taken when strictly aboriginal types of shelters still prevailed, correct such an impression and illustrate the great variability brought about by the adaptation of construction to various special conditions and circumstances.

The photographs of the Southern Paiute, however, were evidently taken during the warm season and thus throw no light on the winter house. Other tribes of these deserts used shelters comparable to these during the summer, but in winter, when they settled down near their stored foods to remain during the cold weather, they erected somewhat sturdier and larger conical lodges. During the summer, such lodges were not only unnecessary but inappropriate. The subsistence routine required continual movement from one locality to another as different foods became available. Shelters were, therefore, no more than temporary structures designed only for the few days or weeks that would be spent at any food camp. Powell<sup>4</sup> wrote of the Kaibab Paiute, "During the inclement season they live in shelters made of boughs, or bark of the cedar, which they strip off in long shreds. In this climate, most of the year is dry and warm, and during such time they do not care for shelter. Clearing a small, circular space of ground, they bank it around with brush and sand, and wallow in it during the day, and huddle together in a heap at night, men, women, and children; buckskin, rags, and sand."

The extreme of simplicity in Kaibab shelters was to pitch camp beneath a tree, little or no effort being made to improve upon nature (pls. 11, 12, 13, *b*). When construction was undertaken, houses tended to be semiconical, erected either upon poles planted in the ground or upon interlocking poles (pl. 21, *a, b*) or almost completely conical (pl. 14, *a*). House poles were covered with various materials, no doubt those which were locally available, such as boughs (pl. 9, *a, b*) and willows (pl. 10, *b*). One house had a fire in the center and the roof open above (pl. 20, *a*).

The Ute had acquired the tipi through contact with the Plains tribes. Those shown in the photographs (pls. 23, *a, b*, 24, *a*, 25) are all undecorated. That in plate 24, *a*, was, according to the title of the picture, made of elkskin. When tipis could not be built or when they were unnecessary, a conical house, described by informants as similar to the brush house of the Paiute and Shoshoni, was used. That shown in plate 26, *b*, however, is larger and better constructed

<sup>4</sup>Op. cit., p. 126.

than the Southern Paiute lodges, having longer, cleaner poles. It is, in fact, more a tipi covered with boughs and some canvas in place of skin.

#### CAMP ACCESSORIES

If these photographs truly represent aboriginal practise, the use of the tripod extended far south in the Intermontane area. The Kaibab used it to suspend the cooking pot (pl. 13, *b*), though the pot in question is evidently of iron, and the Uintah used it not only for cooking (pl. 25) but as a support on which goods were hung (pl. 24, *a, b*).

The backrest, consisting of a tripod supporting horizontal slats, is shown in a Uintah Ute lodge (pl. 26, *b*). These Ute also used horizontal bars for supporting dried maize (pl. 26, *b*).

Of special interest is the tree platform (pl. 23, *b*) and the two-story construction (pl. 25). It is not clear whether the title of the first, "tree lookout" or "the watch tower," designates the pose of the boy on the platform or the purpose of the platform. The second structure, called "shelter," seems actually to have served as a shelter and storage place. Note the notched log which serves as a ladder.

#### BASKETRY

The basketry of the groups represented here has an interesting place in western American basketry. It is generally believed that both the coiled and twined basket weaves originated at some place on the Pacific coast and spread inland, the former being invented first and attaining a wider distribution than the latter. Thus, only coiling was known to the Basket Makers, the oldest known weavers in the Southwest, and to the Ute, who are on the eastern fringe of the basket area. West of the Ute, however, tribes used both coiling and twining. The latter, being more easily made, was used by Shoshoni and Northern Paiute for such utility baskets as conical seed baskets, winnowing trays, seed beaters, hats, and water jugs, whereas coil was employed only for the somewhat more ornamental trays and bowls. A few Shoshoni of central Nevada appear even to have abandoned coiling entirely in favor of twining.

The photographs suggest that among Southern Paiute, both types of weave were used for all kinds of baskets except possibly hats. Thus it would appear that strict cultural tradition did not entirely determine the weave used, but that the choice in each case depended somewhat upon individual or perhaps family taste. The Kaibab group shown in plate 11, for example, coiled all their baskets—conical

seed basket, water jug, circular trays, and receptacles—though other Kaibab Indians used twining for many of these vessels.

The Uintah Ute baskets in these photographs resemble those in a large collection at the University of Utah. All are coiled, being extremely crudely made and limited in range of forms. A problem still to be solved by anthropology is whether the Ute had, in prehorse days when they depended more upon seed gathering than upon hunting, the full range of basketry forms known to the other Shoshonean tribes. It seems certain, though it has not been proved, that the radical change wrought in their economy by the introduction of the horse would have caused them to abandon many traits connected with seed gathering in favor of things pertaining to hunting.

Basketry forms are clearly shown in the photographs. They include hats, conical seed or burden baskets, seed beaters, winnowing or parching trays, flat trays, water jugs or ollas, and receptacles or bowls. (Cradles, though often made with a basketry technique, are treated separately.) The distinction between twining and coiling is usually clear, especially if the photograph is examined with a glass. Illustrations of the uses of baskets are in most cases probably accurate, though posing the subjects seems to have misrepresented a few. The woman in plate 1, *c*, for example, is gathering seeds in a basketry hat, a dubious procedure.

*Hats.*—Basketry hats, which are widespread throughout the West and on the Pacific coast, are shown in all groups here except the Uintah Ute. All hats appear to be twined. Two somewhat distinct, though similar, forms are illustrated. One is hemispherical, either with a rounded top, like the Moapa Paiute specimens (pl. 1, *c*, 3, *b*) and the Las Vegas hat (the girl on the right, pl. 6, *c*) or with a pointed top, like the Kaibab specimens (pls. 10, *b*, 11, 15, *b*, 16, *b*). The other form is a somewhat truncated cone, the Las Vegas example (pl. 6, *b*, *c*). These hats are either undecorated or bear one or two bands of geometric figures (pls. 1, *c*, 3, *b*, 6, *b*).

Among Shoshonean tribes, basketry hats were worn only by women, serving the double purpose of protecting the head from carrying straps attached to burdens and from pitch when gathering pine nuts.

*Conical baskets.*—These are large, conical baskets used by women both for gathering seeds and for carrying burdens. Powell<sup>5</sup> states that for gathering seeds, "they have large, conical baskets, which hold two or more bushels. The women carry them on their backs, suspended from their foreheads by broad straps, and with a smaller

<sup>5</sup> Op. cit., p. 127.

one in the left hand, and a willow woven fan in the right [the seed beater], they walk among the grasses, and sweep the seed into the smaller basket, which is emptied, now and then, into the larger, until it is full of seeds and chaff . . ." Conical baskets, similarly used throughout the Intermontane area, were of vital importance in native economy.

All the specimens illustrated in the photographs are twined with the exception of the Kaibab specimens, plate 11. Whether they were tightly or loosely woven depended upon the size of the seed to be gathered. Open-twined baskets, having a slight space between the weft elements, were more quickly made than those which were tightly woven and were equally serviceable for holding large seeds such as pinyon nuts.

The photographs show a Moapa Paiute open-twined basket (pl. 1, *c*), a Kaibab basket in the process of manufacture (pl. 9, *a*), several close-twined Kaibab specimens (the edge showing in pl. 13, *a*; two in the foreground of pl. 13, *b*; two specimens being carried in pl. 16, *b*), and a St. George open-twined specimen (pl. 20, *a*).

*Seed beater*.—Only one example of a seed beater is illustrated. It is the Kaibab specimen, shown on the house in plate 9, *a*. It is open-twined and has the service edge reinforced with a wooden rim.

*Winnowing or parching trays*.—As most of the seeds available in Southern Paiute territory are small and hard-shelled, a special technique was required to separate the seeds from the chaff and, after the seeds were ground, to remove the coarse particles. For this purpose, a flat fan-shaped or circular tray was constructed. But it also served another purpose. Having little pottery in which to boil seeds and no doubt finding it too difficult to boil them in water in tight baskets into which hot rocks were dropped, they generally roasted them. Powell<sup>o</sup> observed, "they put the seeds, with a quantity of red hot coals, into a willow tray, and, by rapidly and dexterously shaking and tossing them, keep the coals aglow, and the seeds and tray from burning. As if by magic, so skilled are the crones in this work, they roll the seeds to one side of the tray, as they are roasted, and the coals to the other."

Three specimens of twined winnowing or parching trays are illustrated. Whereas such trays are usually fan-shaped among Shoshoni and Northern Paiute, one of the Kaibab specimens (pl. 16, *b*) is circular. The shape of the other, which was placed so as to catch the meal ground on a metate (pl. 13, *a*), cannot be ascertained. It appears to be fan-shaped.

<sup>o</sup> Op. cit., p. 127.

Of the five, flat, circular, coiled Kaibab trays (pls. 10, *b*, 11, 12, 13, *a*, 16, *b*), it is probable that some are winnowing trays, especially that shown in plate 11.

*Ollas or water jugs.*—Some means of carrying water was an absolute necessity on the long trips through the deserts. Tightly-woven, pitch-coated ollas or jugs solved the problem quite adequately.

Whereas Shoshoni and Northern Paiute ollas are twined and generally have bottoms which taper to a point, Ute and Southern Paiute specimens are predominantly coiled and spherical in shape, like those of the early Basket Makers. The photographs show several specimens among the Kaibab (pls. 11, 12, 9, *a*, *b*, 13, *b*, 16, *a*) and the Ute (pl. 26, *b*, with the handles) all of which appear to be coiled. The necks of these baskets are somewhat wider than those of the Shoshoni and Northern Paiute, for example, plate 9, *a*. The neck in plate 9, *b*, is even flaring.

*Receptacles.*—Pottery has been recorded among both Southern Paiute and Shoshoni Indians. It seems, however, to have been of minor importance and no specimens appear in the photographs. For general purposes requiring receptacles and even for boiling water, basketry bowls were used.

Several Kaibab and Ute coiled basketry bowls are illustrated. The Kaibab examples (pls. 9, *a*, 10, *b*, 11, 12) range in form from exceedingly shallow containers, approximating trays, to nearly hemispherical bowls. Plate 12 shows a woman weaving a coiled bowl. The Ute bowls (pl. 26, and, hanging from the tree, pl. 23, *a*) are very crudely woven, narrow-mouthed, and deep.

#### WEAPONS

*Bows.*—Although the evidence of these photographs is insufficient to postulate important local differences in bow types, several styles appear to have been restricted to certain groups.

Two Moapa bows in plate 1, *b*, are notable for their great length, though a shorter Moapa bow appears in plate 2, *a*, *b*. None of these have recurved ends.

Bows with recurved ends are shown only among the Las Vegas (pls. 5, *a*, *b*, 4, *a*, 6, *b*). That in the left foreground of plate 4, *a*, is clearly sinew-backed. The bow of extraordinary width in plate 5, *c*, appears to be made of two pieces, joined at the grip, and is probably of mountain sheep horn, which was widely used for bows among these people.

The Kaibab bows are comparatively short and lack the recurved ends (several hanging on the right side and in the center of the house

in plate 10, *b*; one leaning against the house in plate 11; one by the child in plate 12; those in plates 17, *a, b*, 18, 19, *a*). Powell<sup>7</sup> said of Kaibab bows, "Most of their bows are made of cedar, but the best are made of the horns of mountain sheep. These are taken, soaked in water, until quite soft, cut into long thin strips, and glued together, and are then quite elastic."

*Quivers.*—Quivers are represented in several photographs, some of which, if correctly posed, show the manner of carrying them. The fur quiver of the Moapa (pl. 1, *b*) was slung over the right shoulder and under the left arm, so that the arrow had to be pulled over the right shoulder. The Moapa fur quivers in plate 2, *a, b*, were hung across the chest, or, more accurately, around the neck with the openings to the right.

A fur Kaibab quiver is shown on the ground in plate 22, *c*.

A Uintah Ute quiver (pl. 29, *a, b*) has a bow case attached. A flap, ornamented with a striped border, symmetrical floral designs and metal studs, hangs from it.

*Shooting.*—Though posed, the Las Vegas man (pl. 5, *a*) and the Kaibab man (pl. 18, *a*) probably hold their bows in accordance with native usage, for this slanting position was common throughout the area.

*Clubs.*—A Moapa club of the "potato masher" type, similar to that used by the Colorado River tribes, appears in plate 2, *c*.

*Knives.*—Several hafted flint knives are shown in the photographs. Though these cannot be studied in detail, even with the aid of a glass, all appear to be essentially the same. A chipped flint blade is fitted into the end of a short wooden handle, which is wrapped just below the blade. Two knives appear on the ground near the right end of the bow in the left foreground of the Las Vegas picture, plate 4, *a*. Several similar knives lie on the ground in the Kaibab photograph, plate 10, *a*. The Kaibab man in plate 9, *b*, is retouching the blade of a knife. He holds it on a pad in his left hand and works with a flaker held in his right hand. The last photograph has also been reproduced and described in Bureau of American Ethnology Bulletin 60, figure 175 and page 309 ff.

*Rodent hook.*—Shoshonean tribes commonly used long sticks with either hooked or slightly forked ends which they inserted into rodent burrows and twisted in the fur of the animals so as to pull them out. Each of the two sticks held in the hand of the Las Vegas man in plate 5, *c*, is equipped with a short hook at one end and may have

<sup>7</sup> Op. cit., p. 128.

been intended for this purpose. Or, they may have been used to pull chuckwallas, a large species of lizard, from rock crevices. Death Valley Shoshoni made similar hooked sticks for this purpose.

#### FIRE MAKING

Fire making is illustrated among the Kaibab Paiute in plate 19, *a*, though the pose of the man in the background is irrelevant to the main subject. The fire drill is compound, as shown by the wrapping near its lower end. That is, it consisted of a main shaft and a fore-shaft. The nature of the hearth cannot be ascertained. The fire maker twirls the drill between the palms of his hands while an assistant holds bark tinder in which to catch the spark.

#### METATES

Metates, or flat stone grinding slabs, were of crucial importance in the preparation of the small, hard-shelled seeds of this country. Powell<sup>8</sup> observed of the Kaibab, "For a mill they use a large flat rock, lying on the ground, and another small cylindrical one in their hands. They sit prone on the ground, hold the large flat rock between the feet and legs, then fill their laps with seeds, making a hopper to the mill with their dusky legs, and grind by pushing the seeds across the larger rock, where it drops into a tray. I have seen a group of women grinding together, keeping time to a chant, or gossiping and chatting . . ."

Two quite unlike specimens of metates appear in the Kaibab Paiute photographs, plates 10, *b*, and 13, *a*. The first, though shallow, has a trough and kind of platform encircling the trough on all but one end where it is open. As this is very similar to the metates used by the early Basket Makers of this region, it is not impossible that it was taken from some ancient site. The other specimen is more like the type commonly used by Shoshoneans, being flat and without any trough. The woman has placed it between her legs with a twined winnowing basket under the far end to catch the flour. She grinds with a thick mano or muller which evidently was used with something of a rotary motion.

#### CRADLES

Two types of cradles are illustrated: the semibasketry type of the Kaibab and the buckskin-covered board (?) of the Ute.

<sup>8</sup> Op. cit., p. 127.

Powell<sup>9</sup> remarks of the Kaibab cradle, "They make a wicker board, by plaiting willows, and sew a buckskin cloth to either edge, and this is filled [sic] in the middle, so as to form a sack, closed at the bottom. At the top, they make a wicker shade . . . and, wrapping the little one in a wildcat robe, place it in the basket, and this they carry on their backs, strapped over the forehead . . . In camp, they stand the basket against the trunk of a tree or hang it to a limb."

The Kaibab cradles appearing in plates 14, *b*, 15, *a*, *b*, and 19, *b*, appear to be related to the "U-ladder" type of the lower Colorado River. But whereas the latter has a stout rod bent into U-shape and covered with horizontal lattice work, the Kaibab cradle has an oval frame covered with vertically placed rods which extend beyond the frame. Plate 15, *a*, shows such a cradle with the hood, infant's head pad, and carrying straps in place.

The Uintah Ute cradle (pl. 24, *b*) is probably a board covered with buckskin. This type, derived from tribes to the north and east of the Intermontane area, never spread beyond the Ute and Northern Shoshoni.

#### DRESS AND ADORNMENT

It is surprising to note the great number of photographs showing persons in full costume. Informants' testimony and early explorers' accounts are unanimous in ascribing extraordinary poverty and scanty attire to Southern Paiute Indians. Even Powell<sup>10</sup> observes "They wear very little clothing, not needing much in this lovely climate." One gets the impression that the hunter who was able to acquire sufficient deer or antelope skin to tailor himself and his wife complete garments was exceptionally lucky. People were usually described as completely or nearly nude, or, at best, draped only in a rabbit-skin blanket. Yet the photographs show a large number of men attired in shirts, breachclouts, leggings, moccasins, and sometimes skin hats, and women fully clad with dresses, peplums, and moccasins. Perhaps the truth of the matter is that most persons possessed all essential garments but, like the old men in plate 1, *b*, they did not ordinarily wear them. To what extent they utilized their entire wardrobes or even borrowed clothing at the instigation of Powell and Hillers for the very special purpose of having their pictures taken is impossible to know. It is clear, however, that many of the subjects of the photographs were specially arranged. Individuals were sometimes taken,

<sup>9</sup> Op. cit., p. 127.

<sup>10</sup> Op. cit., p. 126.



in successive pictures, in various stages of dress and undress. Consequently, the ensemble cannot always be taken as native custom.

Children, though sometimes equipped with garments like those of their elders, were frequently entirely nude and are so represented in several pictures.

*Headdress.*—The hair of Moapa, Las Vegas, and Kaibab Paiute women was rather consistently cut to a short, choppy bob of about shoulder length. Only the Las Vegas woman shown in plate 6, *a*, has bangs. Women sometimes confined their hair with a narrow band (pls. 9, *b*, 14, *b*, 18, *b*, *c*, *d*, 19, *b*), sometimes with a basketry hat. The head bands worn by the three girls seated on the left in plate 14, *b*, appear to consist of two rows of beads (or quills?) each. The girl next on the right has a band of shells or seeds. Similar bands appear in plate 18, *b*, *c*, *d*.

Southern Paiute men either cut their hair the same as women or allowed it to grow somewhat longer, parting it roughly in the middle or, occasionally (pl. 1, *a*, pl. 10, *b*) on one side. Several Kaibab men clearly have braids: the person on the left in plate 19, *a*; the man with folded arms in plate 19, *b*; the man standing on the right in plate 17, *b*; and the man seated in the foreground in plate 17, *a*. The braids of the last are wrapped. Other men may have braids which do not show.

Five kinds of hair ornaments appear on Southern Paiute men: bands; skull caps; feather crowns; feathers; a forehead ornament.

Bands, which are unusual, are shown among the Moapa (pl. 3, *a*), the Las Vegas (pl. 4, *a*, *b*), and Kaibab (pl. 7).

Skin caps, which are similar to those used widely throughout the Shoshonean area to the west, appear in several photographs. The Moapa men in plate 1, *b*, have skull caps held in place by chin straps. The Moapa boy's cap (pl. 2, *d*) appears to be similar to these but lacks the chin strap. The Las Vegas man on the left in plate 4, *a*, *b*, has a head band rather than cap. The man on the right in plate 4, *b*, has a cap which apparently has animal horns and ears on top. Although the species of animal cannot be identified in this case, it resembles many Shoshoni caps made of the polls of young mountain sheep with the ears and horns left in place. This specimen also has a chin strap. A similar or perhaps the same hat appears on the Las Vegas man in plate 5, *c*. A more conical skull cap with chin strap is shown in plate 4, *a* (second from the left) and in plate 5, *a*. No Kaibab or Ute men have such caps.

Crowns, consisting of hawk or eagle feathers inserted in a head band to stand vertically, are shown in several plates. No information

is available concerning the use of this headgear, but its frequency in the pictures is no proof that it was an article of everyday wear, especially as most of the groups are obviously dressed and posed for the photographs. Among Owens Valley Paiute in California, this type of headdress was used only as dance regalia. A Moapa example appears in plate 2, *b*. Kaibab examples are shown in plates 8, 14, *a*, 17, 18, *a*, *c*, and 19, *b*. Plate 20, *c*, shows a St. George specimen.

A number of feathers are shown attached loosely to the crown of the hair in two Las Vegas photographs (pls. 4, *a*, 5, *b*).

A forehead ornament, evidently attached to some kind of band running up the part of the hair, is shown in two St. George pictures (pls. 20, *a*, 22, *b*).

Attention should be called to the striking beards on several Las Vegas men in plates 4, 5, *c*, and 6, *a*. When Escalante reached western Utah, probably in the vicinity of Utah Lake near the boundary line between Ute and Southern Paiute, on his return journey in 1776, he remarked that the Indians had Spanish features (not evident here) and wore beards.

Uintah Ute headdress and coiffure is not unlike that of the Southern Paiute. Some Ute women, however, wore their hair somewhat longer (pls. 28, *c*, 27, *c*). At least two men have braids (pls. 27, *b*, 29, *c*), while the boy in plate 31, *d*, appears to have a small lock on each side of his head stuck through a section of bone. The men's forehead ornament appears in plate 31, *b*, *c*. Wrapped locks are shown in plates 26, *a*, 29, *c*, and 31, *b*, *c*. Plates 26, *a*, 27, *b*, and 29, *c*, also show the forelock brushed up and back in Plains fashion.

*Men's shirts.*—A common style of men's shirts seems to have prevailed among these groups. The illustrations do not reveal whether it was constructed of one or two skins. A characteristic feature is what appears to be a heavily fringed, V-shaped insert on the front but which, judging from specimens in Powell's collection in the United States National Museum, is more likely a flap. This appears among the Moapa (pl. 2, *a*, *b*, *c*), the Las Vegas (pl. 6, *b*), the Kaibab (pls. 11, 18 *c*, 19, *a*, *b*), and the St. George Paiute (pls. 20, 22, *a*, *c*) and also among the Uintah Ute (pls. 28, *a*, 29, *a*, *c*).

Though fringed sleeves seem usually to have been added to these shirts, a portion of the shirt proper projects slightly as a shoulder flap and is heavily fringed. Long, fringed sleeves appear, for example, among the Moapa (pl. 3, *a*), the Kaibab (pls. 18, *a*, *c*, 19, *a*, *c*), the St. George (pl. 20, *b*, *c*), and the Ute (pls. 28, *a*, *b*, 29, *a*, 31, *d*).

The bottoms of these shirts may or may not be fringed.

Some men's shirts seem to have been constructed of one piece of skin, like a poncho. No doubt whether one or two pieces were used depended upon the size of the skins available. The Kaibab shirt on the man in plate 9, *b*, and on the man kneeling on the left in plate 19, *a*, appear to be one-piece. The Ute shirt in plate 27, *b*, is probably the same, though evidently made of cloth. The Las Vegas shirt (pl. 5, *b*) seems to be poncho style but has a heavy fringe across the chest. Several boys' shirts are evidently one-piece, having a perforation for the head and the edges brought together and fastened below the arms, with all edges fringed: the Moapa (pl. 2, *d*), Las Vegas (pl. 5, *a*) and Kaibab (pl. 14, *a*).

A shirt constructed like a jacket with the front open is shown on the man seated in the middle foreground of the Kaibab photograph, plate 17, *a*.

In addition to heavy fringe, some men's shirts have ornamental designs. The most popular style was a band of geometric figures running from the back across each shoulder and down the chest and a similar band running down the outside of each sleeve. The designs are geometric, usually simple bands of squares and rectangles. So far as can be seen, these are probably made of beads. Such ornamentation appears among the Kaibab on a man who is shown in plate 11, plate 17, *b*, and, shooting a bow, in plate 18, *a*. It also is seen among the Ute, plate 27, *b*.

*Breechclouts*.—Men wore comparatively long breechclouts. These are illustrated among the Moapa (pl. 1, *b*), the Las Vegas (pl. 4, *b*), and the Uintah Ute (pls. 26, *a*, 27, *a*, *b*, 29, *b*, 31, *b*, and, appearing under the shirt, in 29, *a*).

*Men's leggings*.—Men's leggings are shown among all groups. Usually these are fringed down the outside of the leg along the seam, for example, the Moapa (pl. 2, *a*, *b*, *d*), the Las Vegas (pl. 6, *b*), the Kaibab (pls. 8, 17, *a*, *b*, 18, *a*, *c*, 19, *b*), the St. George (pls. 20, *b*, *c*, 22, *a*, *c*, *d*) and the Ute (pls. 27, *b*, 28, *a*, 29, *a*). The leggings in plate 19, *b*, are also fringed on the bottom. Those in plate 17, *a*, also have a painted (?) design of diamonds near the bottom and those in plate 18, *c*, have beaded designs down the outside of the leg.

A few leggings have the fringe down the front of the leg, e.g., the Kaibab boy (pl. 14, *a*).

*War costume*.—The Uintah Ute photograph, plate 26, *a*, judging from its title, "The Warrior," and its general appearance, probably represents war costume. The man is naked but for the chest ornament, which is probably of manufactured bone brought to these people by the traders, the cartridge belt, breechclout, and anklet. His fore-

lock is brushed back and painted and his body is painted a light color with darker stripes running horizontally around his arms and vertically on his legs.

*Woman's dress.*—It is impossible to ascertain detailed construction of women's attire from the photographs. The Southern Paiute garments, however, seem usually to have consisted of two essential parts—the dress proper and a fringed overskirt or peplum.

From the somewhat artificial ensembles shown in the poses, it is not certain whether the peplum was ever worn alone (though it is so shown in pl. 5, *d*) and might thus be considered a true skirt. Rather, it seems primarily to have filled the function of a belt. It consists of a comparatively narrow girdle, 2 to 6 inches wide, from which falls a fringe 1 to 2 feet long. It serves to gather in the dress about the waist and to provide ornamental fringe, which was abundantly used on all garments. Often, hooves were tied amongst the fringe strings. Examples are shown from the Moapa (pl. 3, *b*), the Las Vegas (pls. 5, *d*, 6, *b*, *c*, *d*), the Kaibab (pls. 14, *b*, 18, *b*, *c*, *d*), and the St. George (pl. 22, *a*, *d*).

The dress proper appears usually to have been made of two pieces. Judging by museum specimens as well as by the photographs, some were merely fastened at the shoulders, the sides being left open below the arms and somewhat held together by the peplum, whereas others were sewed together down the sides below the arms. These dresses lack true sleeves and have instead fringed shoulder flaps, e.g., the Kaibab woman in plate 14, *b*. The sides of the dress were usually also fringed, as in plate 18, *b*, *c*, *d*. Plate 18, *b*, has, in addition, hooves tied to the fringes on both sides and bottom.

Several dresses are further ornamented. The Kaibab woman in plates 15, *a*, *b*, and 16, *a*, *b*, has a thin beaded (?) band running up the sleeve, around the neck, and across the chest. One of the dresses in plate 14, *b*, has parallel bands across the chest.

The Ute dresses seem to have followed more strictly the Plains pattern, probably being made of two skins, one in front and one behind, sewed down the sides. Flaps cover the shoulders and fringing is abundant. These dresses are variously ornamented, several having parallel bands which run from one shoulder flap across the chest to the other (pls. 28, *c*, *d*, 29, *c*). Plate 27, *c*, shows a single band of this kind. In addition to the bands, plate 28, *c*, has a floral design on the skirt near the lower portion of the fringed seam. The bottom of plate 28, *c*, has a fringe, 28, *d*, an ornamental band, and plate 27, *c*, both fringe and band. Several have elk teeth, for example, that in plate 24, *a*, on which they are arranged in four horizontal rows across

the back, and plate 27, *c*, on which they are placed below the ornamental chest band.

*Moccasins*.—Many adults, though completely dressed, are shown barefoot. Others wear moccasins. The moccasins collected by Powell were described by Gudmund Hatt, "Moccasins and their Relation to Arctic Footwear" (Amer. Anthrop. Assoc., Mem. 3, no. 3, 1916).

Kaibab moccasins for both sexes seem to have had separate soles, molded to the foot like the Southwestern types (pls. 17, *b*, 18, *b*, 19, *b*). The St. George moccasins (pl. 20, *c*) are similar. The woman's moccasin in plate 18, *b*, has a high, fringed top, the edge of which is turned down. The top of the Ute moccasin in plate 30 resembles the last. The Ute man standing on the right in plate 28, *b*, has geometric designs on both the instep and uppers of his moccasins.

Of particular interest are the garters supporting the uppers of the Moapa man's moccasins in plate 1, *b*.

*Rabbit-skin blankets*.—Blankets made by twining together twisted strips of rabbit fur were an essential article throughout the Shoshonean area. They served both as robes and bedding. They were worn either instead of or over ordinary clothing.

Several are shown among the Kaibab: the woman with the hat seated in plate 11; two persons in the background in plate 12; three persons seated in plate 13, *b*; and plate 7. Though none are shown among the Uintah Ute, the University of Utah Museum of Anthropology has specimens from this group.

#### TRANSPORTATION

Two devices for transporting goods by human carriers are illustrated: a net wrapped about the bundle in the lower left corner of the Kaibab photograph, plate 14, *a*, and the conical baskets shown in plate 16, *b*.

The carrying strap was used by Kaibab women both as a tump line over the head, as shown with the water jugs (pl. 16, *a*), and as a chest strap, as shown with the baskets (pl. 16, *b*).

#### PARFLECHE

The parfleche is one of the many traits which the Ute acquired from the Plains tribes. A single specimen appears in the foreground of plate 24, *a*.

#### MAIZE

It is of interest that although ethnographic studies report that all Southern Paiute grew some maize and that the Ute did not, the only

specimens illustrated in these photographs are among the Ute. Plates 24, *b*, 25, and 26, *b*, show a large number of ears of various colored and variegated maize hung up to dry. We do not know, of course, whether these were grown by the Ute or traded from the Southwest.

#### EAGLES

Eagles were taken by most if not by all Shoshonean groups and kept captive, though not killed, for their feathers. Plate 27, *a, b*, shows an eagle, the property of a Uintah Ute man, tied to the limb of a tree.

#### DANCING

A single dance is known to have been aboriginal throughout the entire Shoshonean area. This was the round dance or circle dance which was performed primarily for pleasure whenever enough people were present to hold it. It consisted simply of a circle of people who side-stepped or hopped to the accompaniment of singing. It is illustrated among the Kaibab in two photographs, plates 7 and 8.

#### GAMES

Two games are represented, both being widespread throughout the Shoshonean area. The first, shown in plate 4, being played by four Las Vegas men, appears to be a variety of the "basket hiding game," in which several sticks are arranged under a basket by one contestant, the other being required to guess their positions. This game is usually similar to the hand game in that half of the sticks are marked, half unmarked. In the photograph, the man on the extreme right has several sticks, which cannot be studied in detail, concealed under a winnowing basket. His opponent on the extreme left is indicating the position of the sticks by means of motions similar to those used in the hand game. A bundle of twigs appears on the ground to the left of each contestant and a third bundle is between them. These are probably counters which were forfeited for incorrect guesses.

The Kaibab photograph in plate 10, *a*, shows the hand game, which was perhaps the most popular gambling game throughout the west. The men on the left with folded arms hold the sticks concealed in their hands. The man in the center on the right is guessing the position of the sticks by pointing. The rows of twigs stuck into the ground in front of each side are tallies. When one side has lost all these to the other side, it forfeits the stakes of the game. In this case, the stakes seem to have been the beads and knives deposited on the ground in the foreground of the picture.

## HORSES

There is abundant ethnographic evidence to indicate that although the Southern Paiute rarely possessed horses, the Ute were well provided with them. The photographs unfortunately show little pertaining directly to the horse. It is of interest, however, that the few illustrations of Southern Paiute horses show no special horse gear which is evident among the Ute. The photograph in plate 30 shows comparatively elaborate Ute horse trappings. The warrior and the woman on horses in plate 26, *a*, also shows some horse gear.

The Ute photograph in plate 30 is also of interest from the point of view of art. It shows that, like several northern Plains tribes, these Ute had two totally distinct design styles, which appear also on some of their clothing. The floral designs on the horse trappings doubtless had their ultimate origin in the far north. The geometric designs on the bag suspended from the saddle, however, follow more closely the conventions of Plains parfleche and other rawhide ornamentation.

## EXPLANATION OF PLATES

The following information is taken from the catalog of these photographs. The number following the plate reference corresponds to that in the Bureau of American Ethnology negative files. The tribal reference is a condensation of catalog information, explained more fully below. The first title of each photograph is from Powell. The second title, in parentheses, is from Hillers' catalog.

The Powell catalog gives the following tribal references:

Plate 1, *a*, "Paiute, vicinity of Cedar, Utah (on the Rio Virgen, a tributary of the Colorado in southern Utah)."

Plate 1, *b* to plate 3, *b*, inclusive, "Paiute, Moapa Valley." The Moapa Valley is in southern Nevada.

Plate 4, *a*, to plate 6, *d*, inclusive, "Paiute, the Vegas or Meadows in southwestern Nevada." This is doubtless the vicinity of the town of Las Vegas in extreme southern Nevada, placing these people south of the Moapa Paiute.

There is some question whether one or two groups are represented in the photographs in plates 7 to 22. Plate 7 to plate 19 inclusive are cataloged as "Paiute, Kaibab Plateau near the Grand Canyon of the Colorado in Northern Arizona." Plates 20, 21, *b*, and 22 are named "Paiute, vicinity of St. George, Utah on the Rio Virgen, a tributary of the Colorado in southern Utah," but plate 21, *a*, is stated to be "Paiute, near St. George, Utah. Kaibab Plateau near the Grand Canyon of the Colorado in northern Arizona." The last, however, is probably an error in recording, for the Kaibab Plateau, though not far from that portion of the Rio Virgen which flows through southwestern Utah, is not itself in Utah. Moreover, the house in plate 21, *b*, is in the village shown in plate 21, *a*. For this reason, all the photographs in plates 20 to 22 inclusive have been taken to represent a separate group of Southern Paiute who are designated St. George.

Plates 23 to 31, inclusive, are cataloged as "Ute. Uintah Valley on the eastern slope of the Wasatch Mountains in Utah." This is a well-defined group, which has subsequently been called Uintah Ute. They occupied the Uintah Basin, a large valley bounded on the north by the Uintah Mountains, on the west by the Wasatch Mountains, on the east by the Green River or perhaps by a vague line somewhat to the east of the river, and on the south by the plateaus and canyon lands of eastern Utah. Of these photographs, plate 28, *d*, is labeled "Paiute (?)," clearly an error as indicated by the attire of the people.

## PLATE 1

- a.* 1636. St. George Paiute. "Tau-gu and Major Powell." ("Tau-gu, head (great) chief of the Paiutes of Arizona and Utah.")
- b.* 1640. Moapa Paiute. "Making a calculation." ("Five and three equal eight.")
- c.* 1641. Moapa Paiute. "Wu-na-vi gathering seeds."

## PLATE 2

- a.* 1637. Moapa Paiute. "Pan-a-wai-tau-a."
- b.* 1657. Moapa Paiute. "Tau-um-pu-gaip, a chief." ("Tau-um-pu-gaip, sub-chief of the Mo-a-pa-ri-ats.")
- c.* 1643. Moapa Paiute. "Ai-at-tau-a, 'beautiful man', chief of the Mo-a-pa-ri-ats."
- d.* 1638. Moapa Paiute. "San-on-kuts."

## PLATE 3

- a.* 1620. Moapa Paiute. "Met on the trail."
- b.* 1639. Moapa Paiute. "Jim-mi-pin-mi and Si-ka-whi." ("Pi-ka-whi.")

## PLATE 4

- a.* 1652. Las Vegas Paiute. "The old gamblers."
- b.* 1650. Las Vegas Paiute. "Two old boys."

## PLATE 5

- a.* 1651. Las Vegas Paiute. "Komoahoats hunting. Also called Jim Pilling."
- b.* 1627. Las Vegas Paiute. "Ta-noats."
- c.* 1644. Las Vegas Paiute. "Enuintsigaip. One of Major Powell's guides." ("E-nu-ints-i-gaip, one of the ancients.")
- d.* 1645-b. Las Vegas Paiute. "Kani."

## PLATE 6

- a.* 1649-a. Las Vegas Paiute. "The brother chiefs and their squaws."
- b.* 1646. Las Vegas Paiute. "Antinaints and Ci-gav." ("Sigav and Antinaints.")
- c.* 1648-b. Las Vegas Paiute. "Antinaints, Putusiv and Wichuts in native dress."



## PLATE 7

1623. Kaibab Paiute. "The Tavokoki or Circle Dance (winter costume)."

## PLATE 8

1622. Kaibab Paiute. "The Tavokoki or Circle Dance (summer costume)."

## PLATE 9

*a.* 1610. Kaibab Paiute. "The basket maker."

*b.* 1600. Kaibab Paiute. "The arrow-maker and his daughter."

## PLATE 10

*a.* 1624. Kaibab Paiute. "The game of kill the bone, 'Ni-aung-pi-kai.'" ("The game of Ni-aung-pi-kai.")

*b.* 1597. Kaibab Paiute. "Chu-ar-ru-um-peak and family in native dress."

## PLATE 11

1604. Kaibab Paiute. "Summer home under cedar (tree)."

## PLATE 12

1605. Kaibab Paiute. "The home circle." ("At home.")

## PLATE 13

*a.* 1611. Kaibab Paiute. "Woman grinding grass seed." ("Woman grinding seed.")

*b.* 1601. Kaibab Paiute. "A domestic camp scene." ("Waiting for the kettle to boil.")

## PLATE 14

*a.* 1602. Kaibab Paiute. "The grandfather's pride." ("Proud of their grandson.")

*b.* 1614. Kaibab Paiute. "Group of women in native dress." ("Group of women in full dress.")

## PLATE 15

*a.* 1617. Kaibab Paiute. "The empty cradle."

*b.* 1599. Kaibab Paiute. "Mother and child." ("The mother.")

## PLATE 16

*a.* 1606. Kaibab Paiute. "Women water carriers." ("The water carriers.")

*b.* 1607. Kaibab Paiute. "Women seed-gatherers." ("The seed gatherers.")

## PLATE 17

- a.* 1613-a-2. Kaibab Paiute. "Groups of tribesmen in native dress." ("Group of men in full dress.")
- b.* 1612. Kaibab Paiute. "Chu-ar-ru-um-peak and his friends. Head chief of the band."

## PLATE 18

- a.* 1618. Kaibab Paiute. "Chu-ar-ru-um-peak shooting. Head chief." ("Chu-ar-ru-um-peak shooting a rabbit.")
- b.* 1593-b. Kaibab Paiute. "Ku-ra-tu."
- c.* 1595. Kaibab Paiute. "The rabbit skin."
- d.* 1589. Kaibab Paiute. "Won-si-vu and Ku-ra-tu (on right)."

## PLATE 19

- a.* 1619-a. Kaibab Paiute. "Kindling fire by friction."
- b.* 1613-b. Kaibab Paiute. "Group of five men and women in native dress. (Showing the wi-geav or feather headdress)."

## PLATE 20

- a.* 1634. St. George Paiute. "The home of Tapeats."
- b.* 1631. St. George Paiute. "The hunter."
- c.* 1626. St. George Paiute. "Moack-shin-au-av, chief of band." ("Moack-shin-au-av, chief of the U-ai Nu-ints.")

## PLATE 21

- a.* 1633. St. George (?) Paiute. "An encampment or village. Ka-ni-ga. The camp ground."
- b.* 1635. St. George Paiute. "Lodges in the village." ("Nu-nu-shi-unt. The dreamer.")

## PLATE 22

- a.* 1629. St. George Paiute. "Mokuiuk and his daughter." ("Mo-kwi-uk.")
- b.* 1625. St. George Paiute. "Ta-peats."
- c.* 1630. St. George Paiute. "Kivitoos and his son."
- d.* 1632. St. George Paiute. "The little hunter and his girl." ("The little hunter and his sweetheart.")
- e.* 1628. St. George Paiute. "Mon-su and Suvuit."

## PLATE 23

- a.* 1538. Uintah Ute. "Indian boy on watch." ("The boy in the cedar.")
- b.* 1548-a. Uintah Ute. "Encampment and tree outlook." ("The watch tower.")

## PLATE 24

- a.* 1546. Uintah Ute. "Encampment showing elk skin tipi. Parfleche bag (?) in foreground." ("The Elkskin tent.")
- b.* 1542. Uintah Ute. "A domestic camp scene." ("Babe in cradle.")

## PLATE 25

1544. Uintah Ute. "Antero's encampment, showing tipi, shelter, etc." ("House of Antero.")

## PLATE 26

- a.* 1535. Uintah Ute. "The warrior and his bride."  
*b.* 1547. Uintah Ute. "Home of Ta-va-puts, head chief." ("Ya-va-puts.")

## PLATE 27

- a.* 1525. Uintah Ute. "Nau-no-kwits and his eagle."  
*b.* 1530. Uintah Ute. "Nau-no-kwits and Qu-u-en." ("Ku-ri-en.")  
*c.* 1522. Uintah Ute. "Shi-ra-sa, wife of To-ka-wah-sae."

## PLATE 28

- a.* 1486-b. Uintah Ute. "Antero, war chief of Ute."  
*b.* 1541. Uintah Ute. "Making a calculation." ("Indians counting.")  
*c.* 1529. Uintah Ute. "Yan-mo, wife of Won-wan, in native dress."  
*d.* 1600-b. Labeled "Paiute" but probably is Uintah Ute. "Visiting the settler."

## PLATE 29

- a.* 1526. Uintah Ute. "Pah-ri-ats, in native summer dress."  
*b.* 1527. Uintah Ute. "Pah-ri-ats, in native summer dress."  
*c.* 1524. Uintah Ute. "Sai-ar and family."

## PLATE 30

1531. Uintah Ute. "Girl on horseback." ("Indian girl on horseback.")

## PLATE 31

- a.* 1533. Uintah Ute. "A young maiden." ("The maiden.")  
*b.* 1539. Uintah Ute. "The runner." ("The messenger.")  
*c.* 1537. Uintah Ute. "A young warrior and his dog." ("Indian boy and his dog.")  
*d.* 1534. Uintah Ute. "Boy and girl."



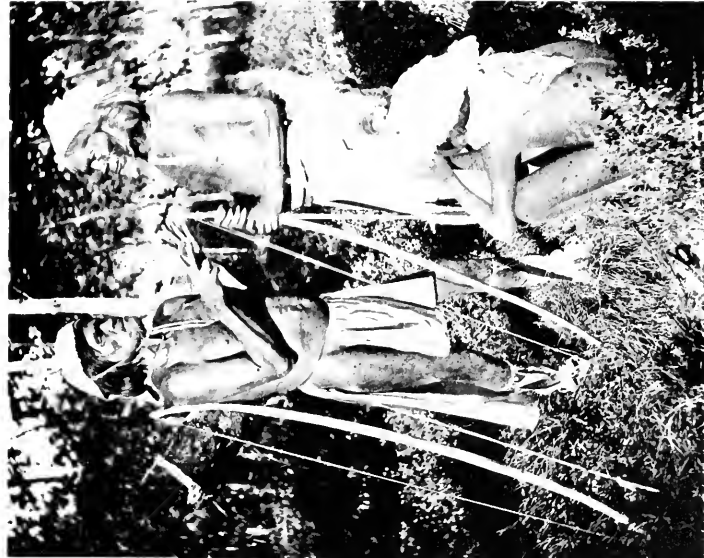

SOUTHERN PAIUTE OF CEDAR, UTAH, AND MOAPA, NEV.

(See explanation of plates at end of text.)



SOUTHERN PAIUTE OF MOAPA, NEV.  
(See explanation of plates at end of text.)

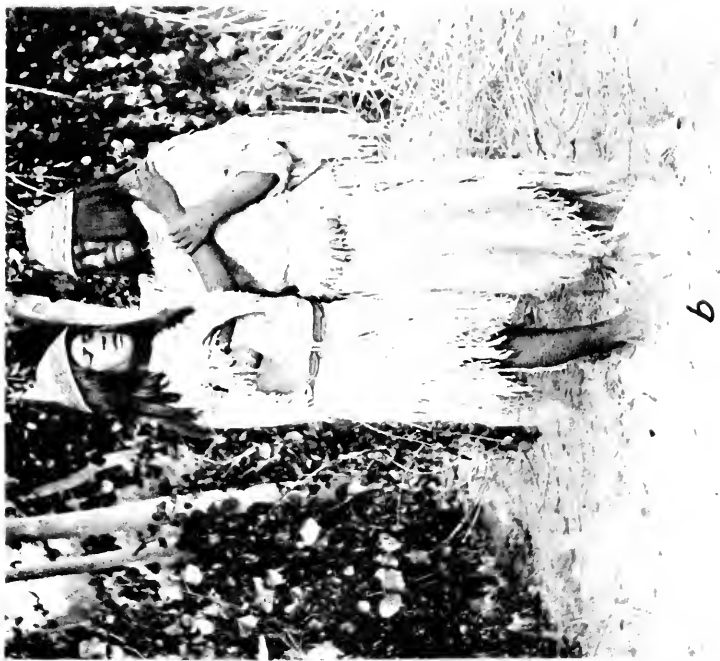

SOUTHERN PAIUTE OF MOAPA, NEV.  
(See explanation of plates at end of text.)



SOUTHERN PAIUTE OF LAS VEGAS, NEV.  
(See explanation of plates at end of text.)





SOUTHERN PAIUTE OF LAS VEGAS, NEV.  
(See explanation of plates at end of text.)

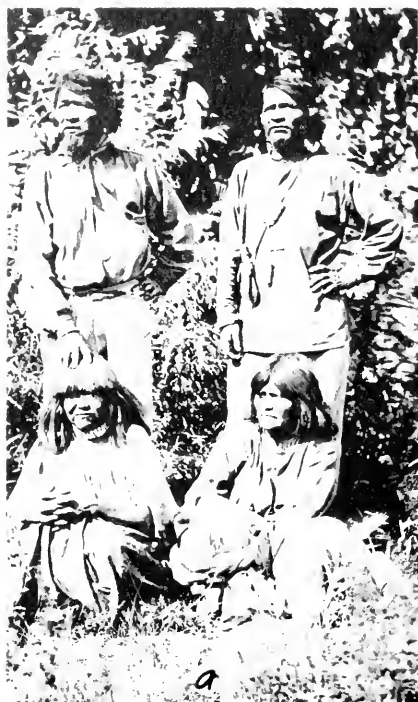

SOUTHERN PAIUTE OF LAS VEGAS, NEV.  
(See explanation of plates at end of text.)



SOUTHERN PAIUTE, KAIBAB PLATEAU, ARIZ.  
(See explanation of plates at end of text.)

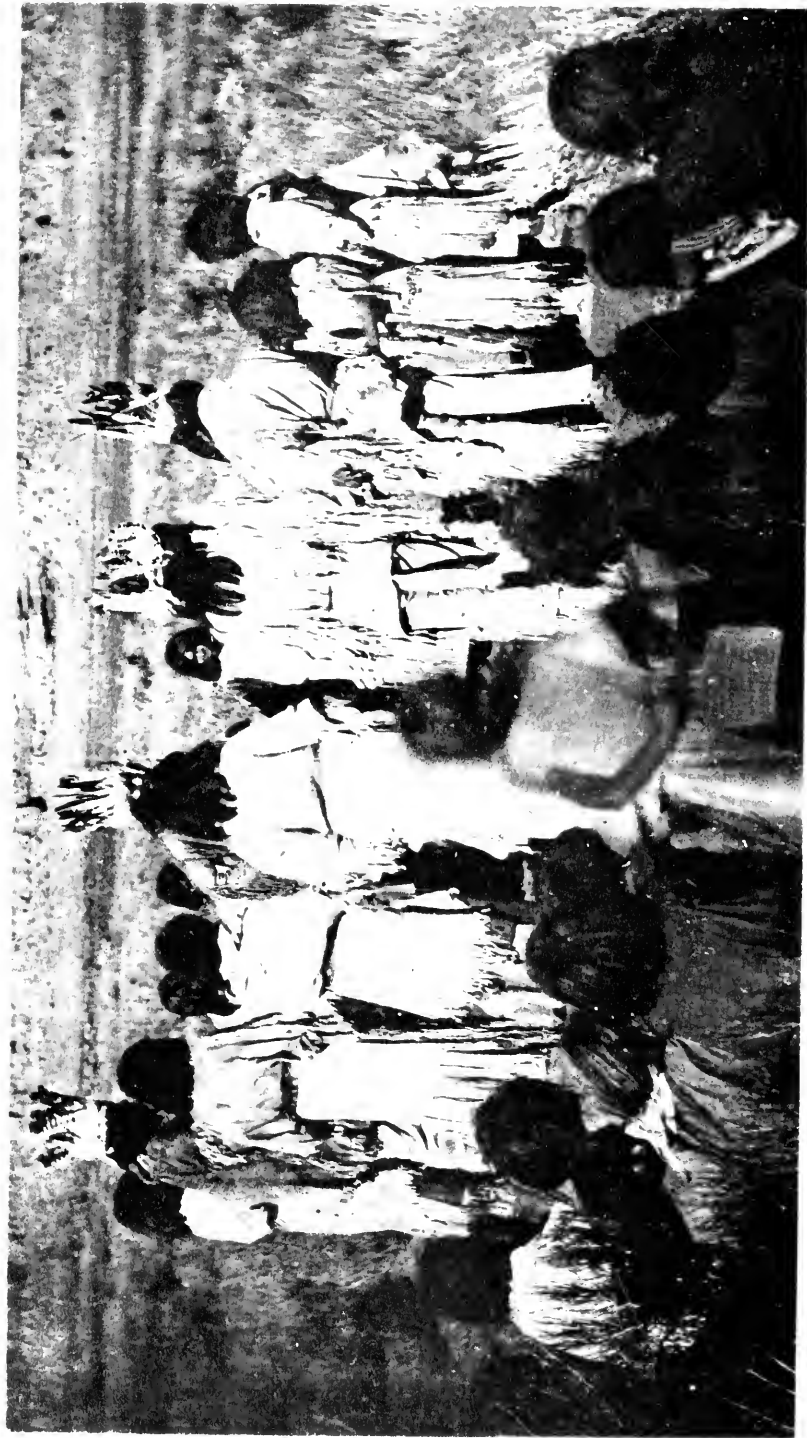

SOUTHERN PAIUTE, KAIBAB PLATEAU, ARIZ.  
(See explanation of plates at end of text.)

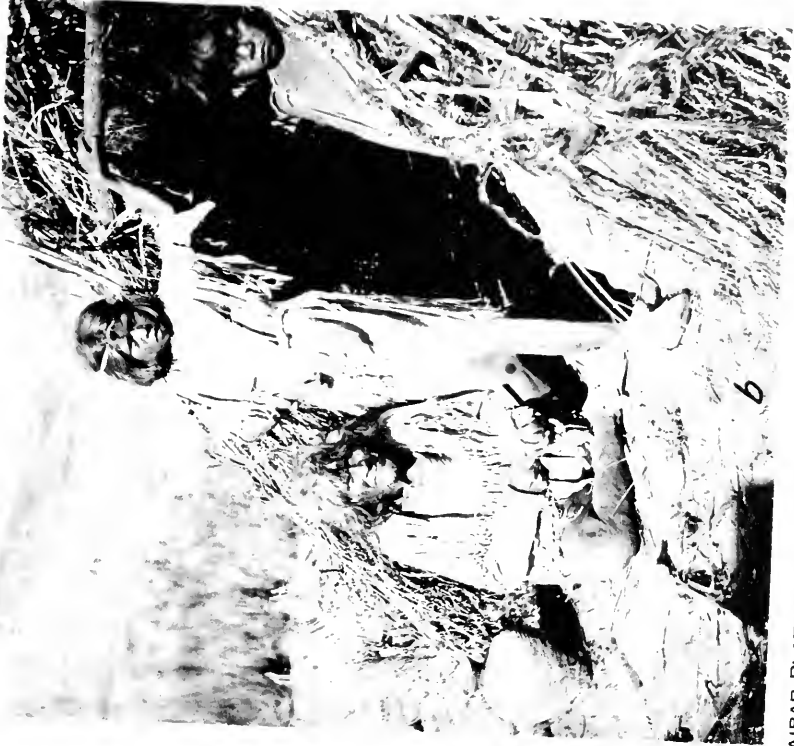

SOUTHERN PAIUTE, KAIBAB PLATEAU, ARIZ.  
(See explanation of plates at end of text.)



SOUTHERN PAIUTE, KAIBAB PLATEAU, ARIZ.  
(See explanation of plates at end of text.)



SOUTHERN PAIUTE, KAIBAB PLATEAU, ARIZ.  
(See explanation of plates at end of text.)



SOUTHERN PAIUTE, KAIBAB PLATEAU, ARIZ.  
(See explanation of plates at end of text.)





SOUTHERN PAIUTE, KAIBAB PLATEAU, ARIZ.  
(See explanation of plates at end of text.)

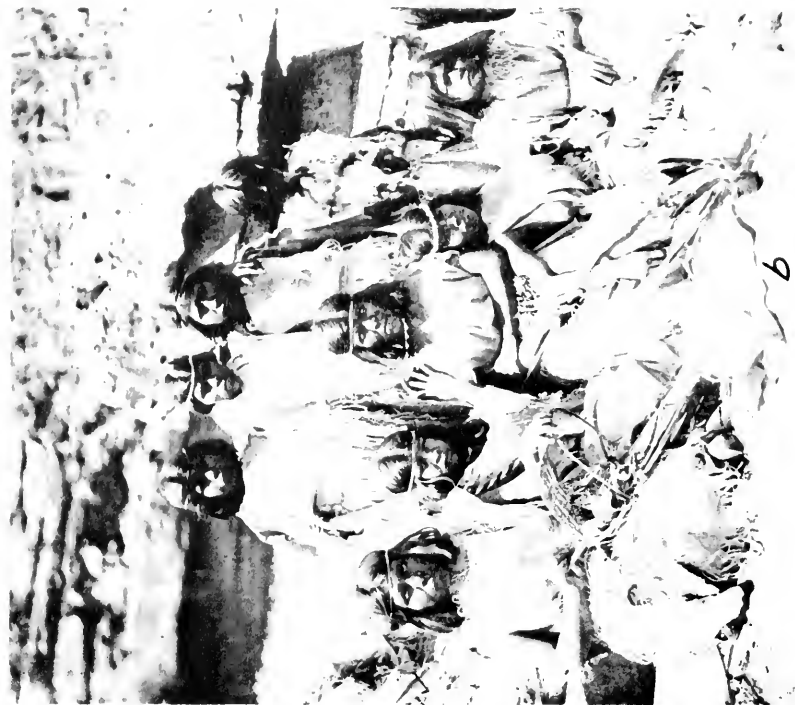

SOUTHERN PAIUTE, KAIBAB PLATEAU, ARIZ.  
(See explanation of plates at end of text.)



SOUTHERN PAIUTE, KAIBAB PLATEAU, ARIZ.  
(See explanation of plates at end of text.)



SOUTHERN PAIUTE, KAIBAB PLATEAU, ARIZ.  
(See explanation of plates at end of text.)



SOUTHERN PAIUTE, KAIBAB PLATEAU, ARIZ.  
(See explanation of plates at end of text.)



SOUTHERN PAIUTE, KAIBAB PLATEAU, ARIZ.  
(See explanation of plates at end of text.)

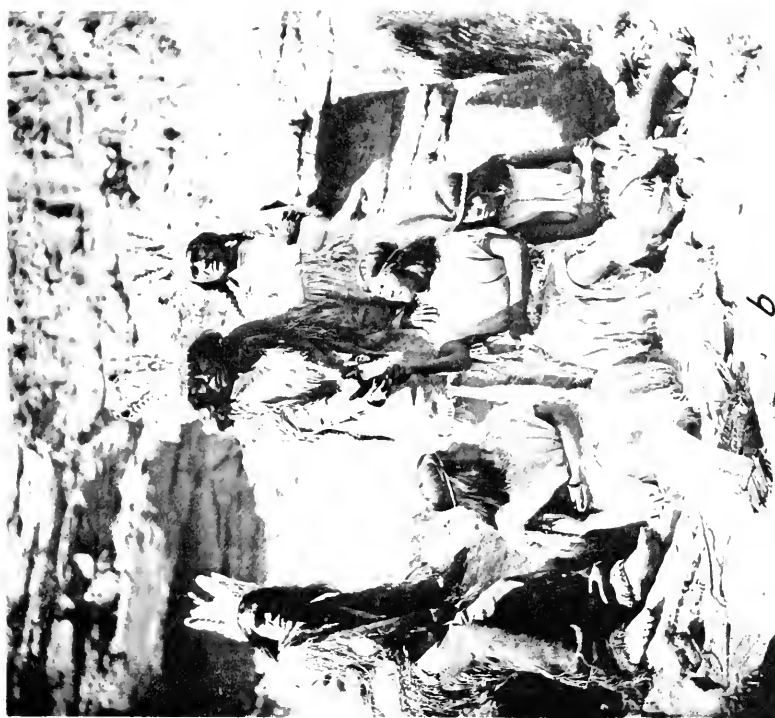
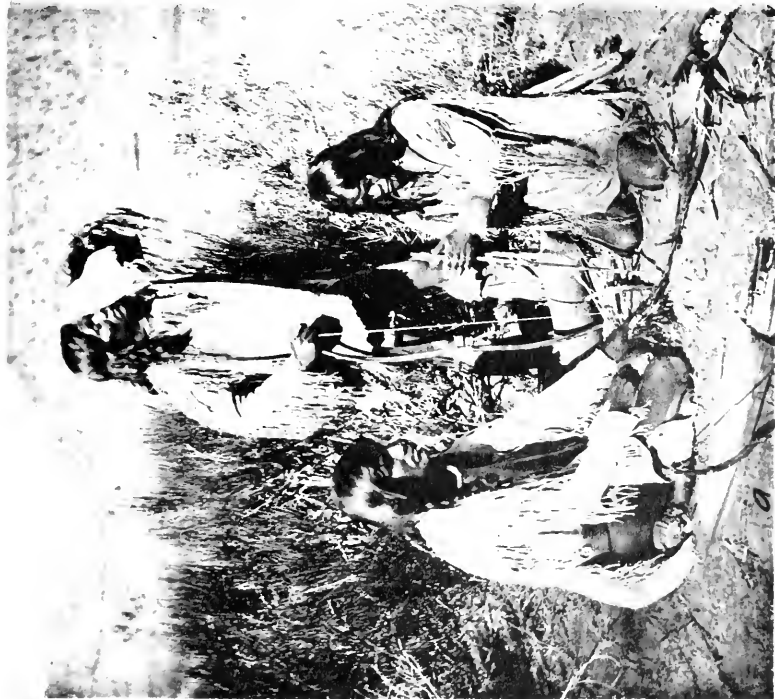

SOUTHERN PAIUTE, KAIBAB PLATEAU, ARIZ.  
(See explanation of plates at end of text.)

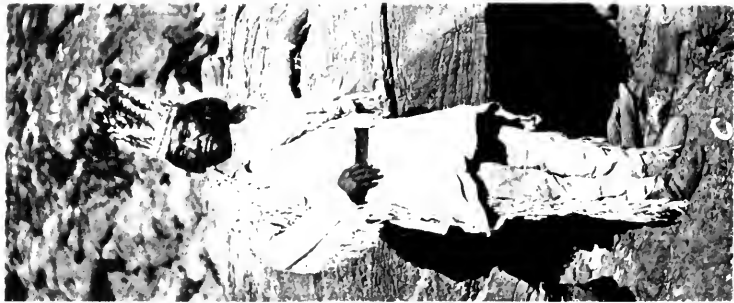

SOUTHERN PAIUTE, ST. GEORGE, UTAH  
(See explanation of plates at end of text.)



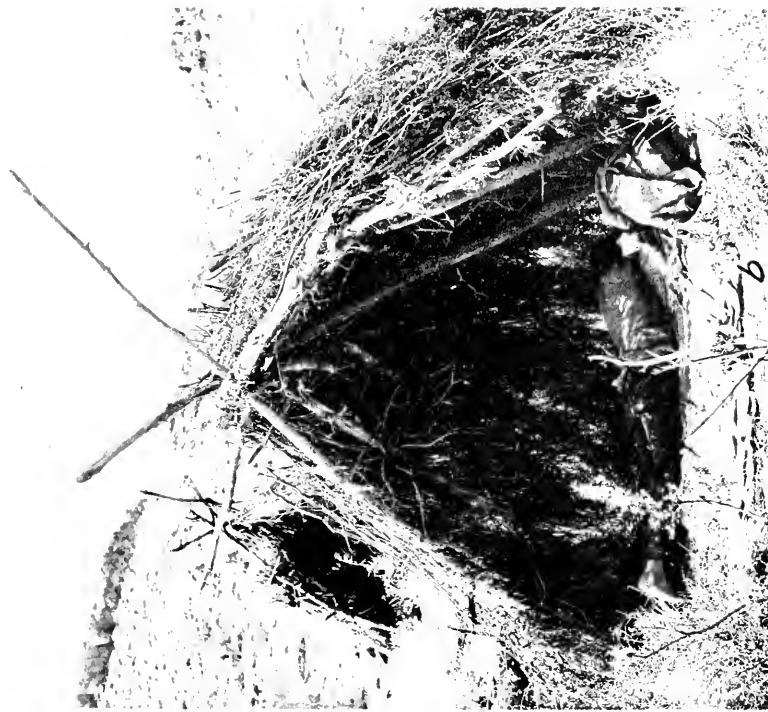

SOUTHERN PAIUTE, ST. GEORGE, UTAH  
(See explanation of plates at end of text.)



SOUTHERN PAIUTE, ST. GEORGE, UTAH  
(See explanation of plates at end of text.)

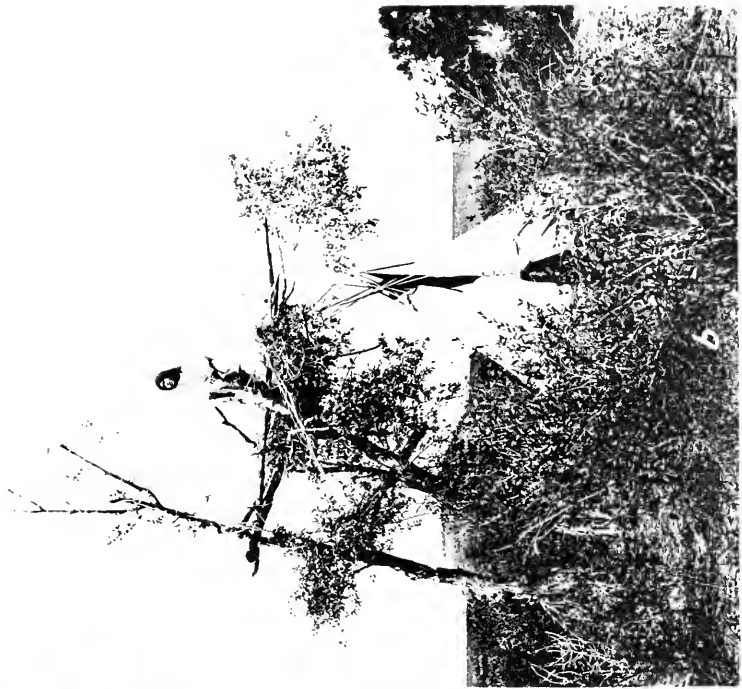
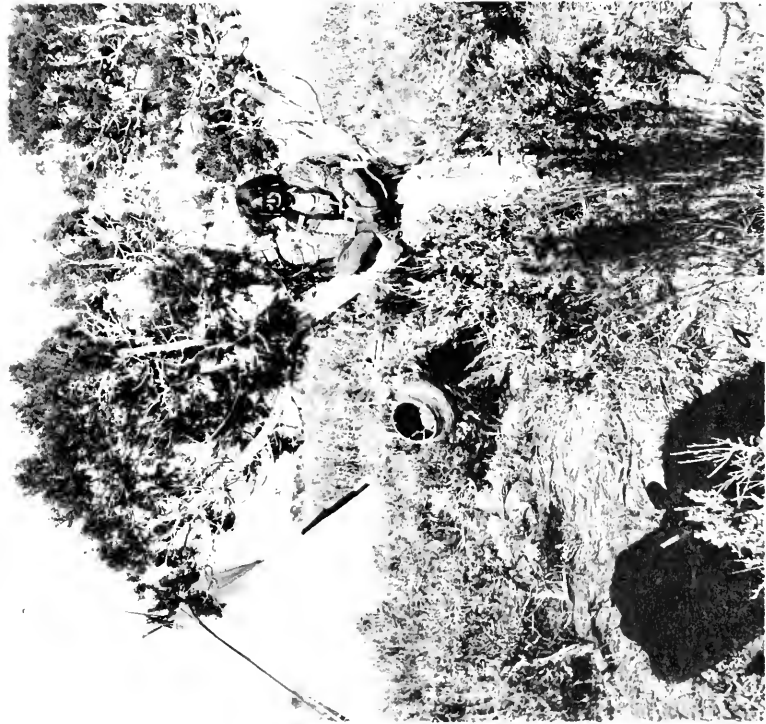

UINTAH UTE, NORTHEASTERN UTAH  
(See explanation of plates at end of text.)



UINTAH UTE, NORTHEASTERN UTAH  
(See explanation of plates at end of text.)

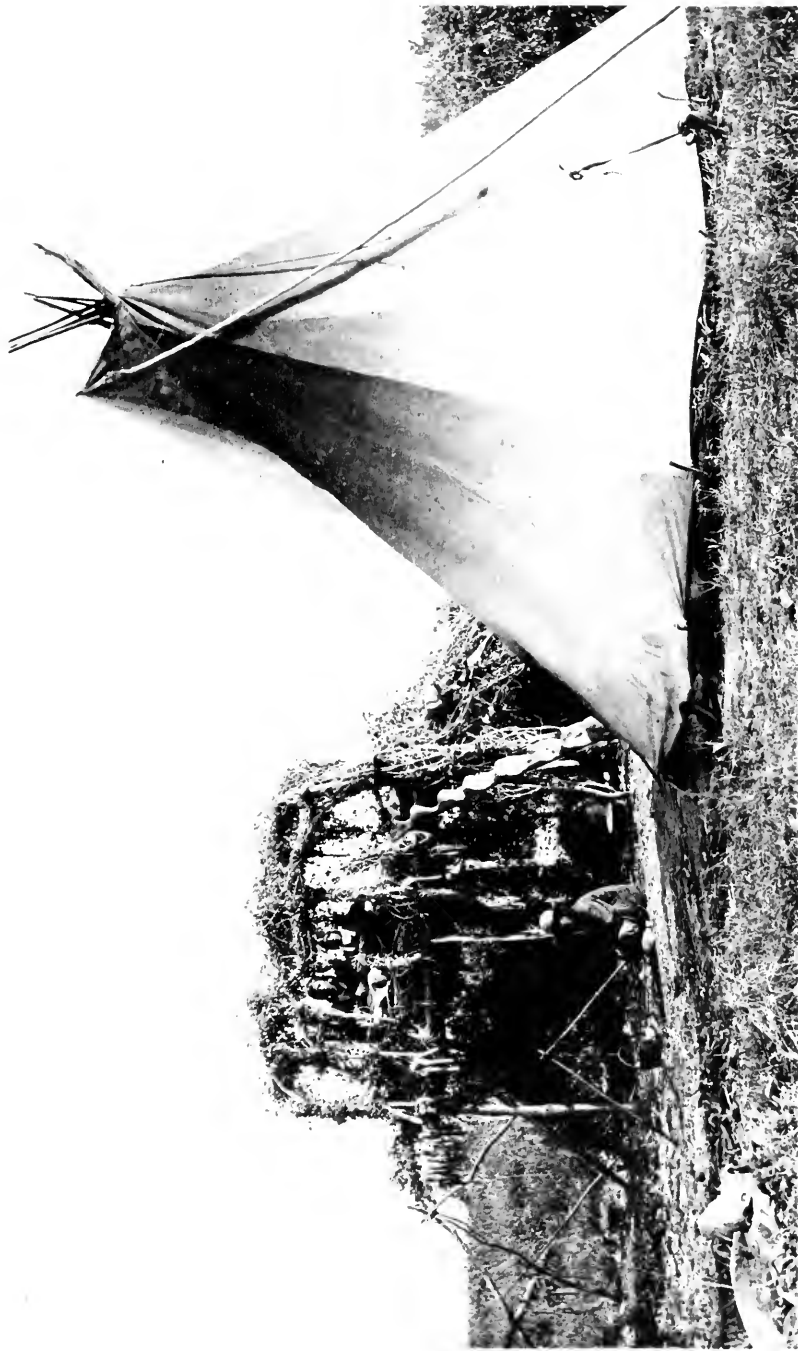

UINTAH UTE, NORTHEASTERN UTAH.  
(See explanation of plates at end of text.)



UINTAH UTE, NORTHEASTERN UTAH  
(See explanation of plates at end of text.)



UINTAH UTE, NORTHEASTERN UTAH  
(See explanation of plates at end of text.)



UINTAH UTE, NORTHEASTERN UTAH  
(See explanation of plates at end of text.)





JINTAH UTE, NORTHEASTERN UTAH  
(See explanation of plates at end of text.)



UINTAH UTE. NORTHEASTERN UTAH  
(See explanation of plates at end of text.)



UINTAH UTE, NORTHEASTERN UTAH  
(See explanation of plates at end of text.)



SMITHSONIAN MISCELLANEOUS COLLECTIONS  
VOLUME 98, NUMBER 19

SMITHSONIAN INSTITUTION  
JUL 31 1939  
OFFICE LIBRARY

# THE DETERMINATION OF SMALL AMOUNTS OF CHLOROPHYLL— APPARATUS AND METHOD

(WITH TWO PLATES)

BY  
EARL S. JOHNSTON  
AND  
ROBERT L. WEINTRAUB  
Division of Radiation and Organisms  
Smithsonian Institution



(PUBLICATION 3545)

CITY OF WASHINGTON  
PUBLISHED BY THE SMITHSONIAN INSTITUTION  
JULY 31, 1939



SMITHSONIAN MISCELLANEOUS COLLECTIONS

VOLUME 98, NUMBER 19

THE DETERMINATION OF SMALL  
AMOUNTS OF CHLOROPHYLL—  
APPARATUS AND METHOD

(WITH TWO PLATES)

BY

EARL S. JOHNSTON

AND

ROBERT L. WEINTRAUB

Division of Radiation and Organisms  
Smithsonian Institution



(PUBLICATION 3545)

CITY OF WASHINGTON

PUBLISHED BY THE SMITHSONIAN INSTITUTION

JULY 31, 1939

The **Ford** Baltimore Press  
BALTIMORE, MD., U. S. A.



# THE DETERMINATION OF SMALL AMOUNTS OF CHLOROPHYLL—APPARATUS AND METHOD<sup>1</sup>

BY EARL S. JOHNSTON AND ROBERT L. WEINTRAUB<sup>2</sup>

*Division of Radiation and Organisms, Smithsonian Institution*

(WITH TWO PLATES)

## INTRODUCTION

The present paper describes a photometric method for the determination of small amounts of total chlorophyll present in plant tissue, and the apparatus employed. The method is based on the fact that chlorophyll has an absorption band in a certain region of the spectrum that does not overlap the absorption bands of other soluble pigments such as carotenoids. Although it is fully realized that other methods have been employed and described, it is nevertheless felt worth while to point out some advantages of this method which is adapted very nicely to certain problems under investigation in this laboratory.

## APPARATUS

The apparatus is illustrated in plate 1 and figure 1. Essentially it consists of a light source properly shielded in a housing and a horizontal optical path in which the chlorophyll solution may be interposed.

A single-filament street-series lamp (1,000 lumens and 6.6 amperes) serves admirably as the light source. This is connected to 10 storage batteries in such a manner as to give 12 volts. A battery source of current is more desirable than the commercial city supply because of its steadiness. Inside the lamp housing is a metal cylinder which may be raised or lowered so as to transmit or intercept the light in its passage through the optical system. From a condensing lens 3 inches in diameter (shown in fig. 1) the light is passed through a Corning heat-resistant, heat-absorbing light shade glass filter 2.66 mm. thick ( $F_1$ ), a Corning heat-resistant pyrometer red, number 241, 48 percent filter, 4.85 mm. thick ( $F_2$ ), and a glass cell 2 cm. thick containing

<sup>1</sup> Presented before the Division of Biological Chemistry of the American Chemical Society, Baltimore, Md., Apr. 3-7, 1939.

<sup>2</sup> The authors wish to acknowledge the assistance of L. A. Fillmen in the construction of the apparatus, and of E. R. Brydon in carrying out the determinations.

distilled water. This water cell ( $F_3$ ) is connected to a small reservoir kept at room temperature and by thermosiphon action the accumulation of heat is minimized. By means of these filters the radiation utilized in the transmission measurements is restricted to the range from 6240 Å. to just beyond the visible in the near infrared.

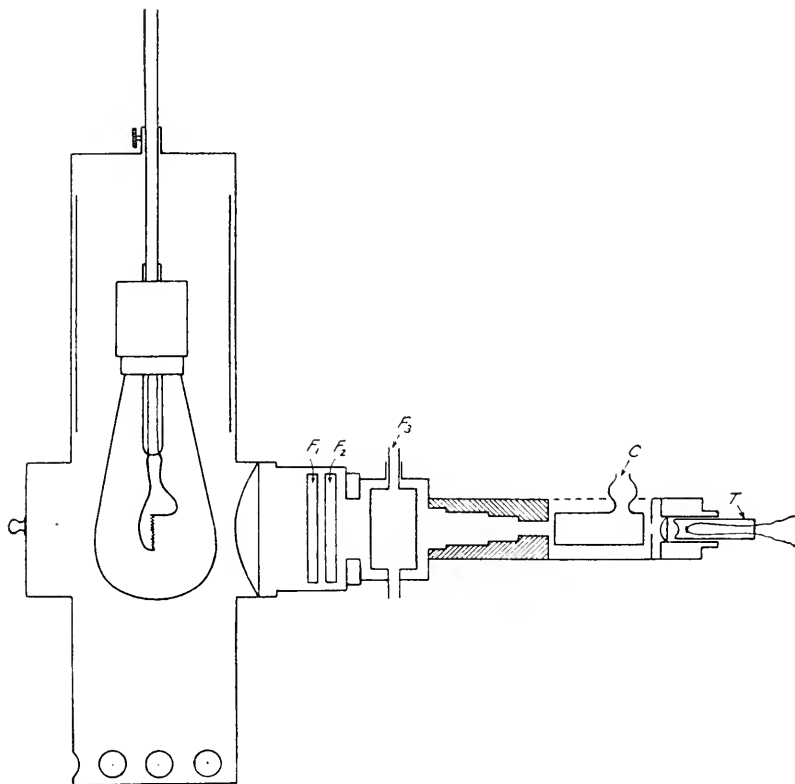

Fig. 1.—Diagram of apparatus used for the determination of small amounts of chlorophyll.  $F_1$ , Corning heat-resistant, heat-absorbing, light shade glass filter, 2.66 mm. thick;  $F_2$ , heat-resistant, pyrometer red, No. 241, 48 percent filter, 4.85 mm. thick;  $F_3$ , glass water cell, 2 cm. thick; C, glass absorption cell 5 cm. long used for holding chlorophyll solutions; T, vacuum thermocouple.

A thermocouple (T) is employed as the energy receiver. The brass thermocouple housing is thermally insulated from the lamp housing by a cylinder of Bakelite whose interior diameter is decreased in steps to reduce internal reflections.

The thermocouple has been developed and built in this laboratory by L. B. Clark. The receiver is a circular disk 1 mm. in diameter and 0.00127 mm. thick. The couple is permanently evacuated to a pressure of less than  $10^{-4}$  mm. mercury which increases its response 20- to

30-fold. It is a rugged type of high sensitivity and has a uniform response over the wide range from 2500 Å. to 6.5  $\mu$ . This transmission range has been obtained by the use of a so-called "bubble window" which is a thin (.025-.050 mm. thick) disk of glass that is fused to the cell body and then sucked in. The couple, whose zero stability is excellent, has a resistance of about 15 ohms and gives 3.3 microvolts per microwatt per square millimeter. Its time response is less than that of commercial galvanometers.

The couple is connected directly to a Moll galvanometer without intermediate means of amplification. This galvanometer has a period of 1.3 seconds with an internal resistance of 50 ohms and the external resistance for critical damping may be varied from 120 to 0 ohms. At a scale distance of 1 m. a deflection of 1 mm. corresponds to a current of  $6 \times 10^{-9}$  amperes.

The absorption cell (C) is 5 cm. long and has a volume of 10 ml. It is constructed of Pyrex glass with fused-on ends.

#### PREPARATION OF EXTRACT

The plant material is thoroughly ground by hand in a mortar with sand and acetone, and the solution decanted and filtered under reduced pressure. The residue, which is retained in the mortar, is ground and the solution filtered twice more, all the filtrates being combined. This requires from 10 to 15 minutes. Carotenoids are not separated from the chlorophyll. It is essential that all suspended material be removed from the solution since the slightest turbidity reduces the transmitted energy and introduces an error in the chlorophyll determinations. After trying several kinds of filters the one illustrated in plate 2 has been found very satisfactory. Several layers of close-grained filter paper are placed in position between the ground faces of the upper and lower portions of the filtering tube. A brass collar fits against a shoulder on each part of the filter tube and by means of screws the ground faces are held tightly against the filter paper.

#### DETERMINATIONS

Before making determinations of unknown chlorophyll solutions it was necessary to construct a calibration curve (fig. 2) from known concentrations of purified chlorophyll solutions.<sup>3</sup> It has been deter-

---

<sup>3</sup>The purified chlorophyll solutions and the unpurified leaf extracts gave identical absorption curves in the region from 6000 Å. to 7400 Å. We are indebted to Dr. K. S. Gibson and H. J. Keegan of the Colorimetry Section, National Bureau of Standards, for the determination of these curves with the General Electric recording spectrophotometer.

mined that additions to the standard chlorophyll solutions of carotene or xanthophyll in amounts up to a hundred times that of the chlorophyll, do not influence the transmission in the spectral region employed.

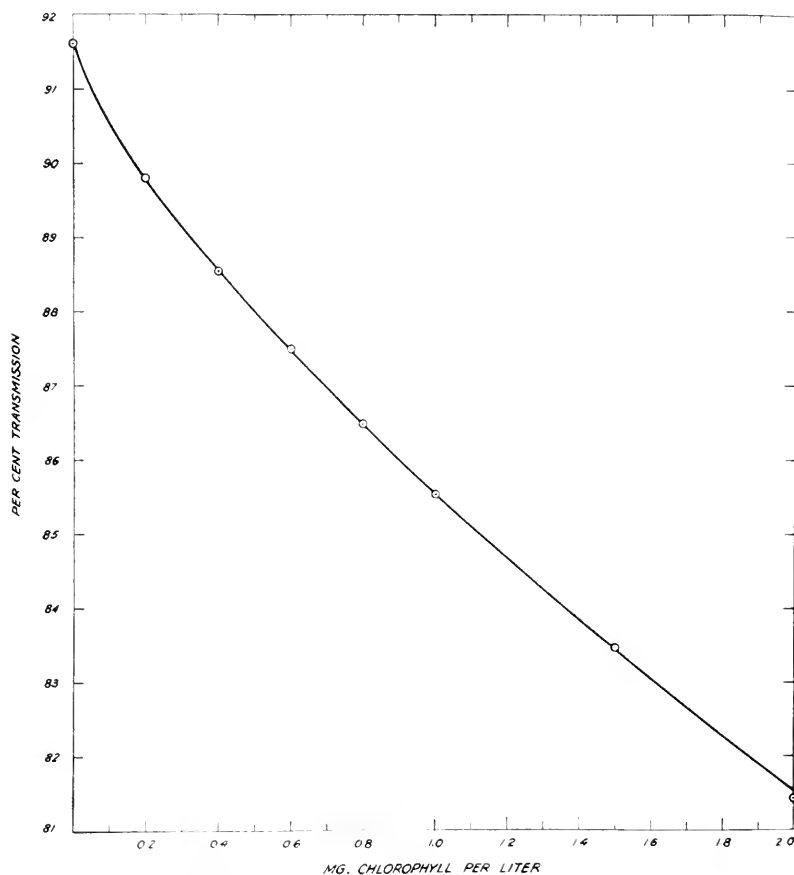

Fig. 2.—Calibration curve showing percentage transmission plotted against milligrams of chlorophyll per liter.

Once this curve has been established the continued use of standard chlorophyll solutions is eliminated. The transmission data obtained from unknown chlorophyll solutions are compared with the calibration curve and the concentrations read directly. The calibration curve used is an empirical one for the particular filters, absorption cell, and solvent employed.

In determining the percentage transmission of a chlorophyll solution the galvanometer deflections with and without the absorption cell and solution in position are observed alternately. The percentage transmission obtained from the average data is used in reading the concentration of chlorophyll from the calibration curve.

About 5 to 10 minutes are required to make the transmission determinations. With the 5-cm. absorption cell the sensitivity is 0.1 microgram (1/10,000 milligram) of chlorophyll. One square centimeter of leaf is sufficient for duplicate determinations which check within 2 to 3 percent. This method is independent of any visual comparisons of intensity or color.

In a study of the influence of the extraction technique on the results, it has been found that preliminary killing of the leaves by immersion in boiling water, or the addition of calcium carbonate during the grinding does not affect the amount of chlorophyll extracted.

Furthermore, in these studies made with barley leaves it was found that the presence of light during the short extraction period is negligible. The chlorophyll content of the extract remains unaltered during at least 2 weeks storage in the refrigerator (about 4° C.).

#### SUMMARY

The method of determining small amounts of chlorophyll herein described is based on the transmission of light in the region of the red absorption band of a solution of chlorophyll in acetone. The transmitted energy is determined by means of a galvanometer and a vacuum thermocouple of extremely high sensitivity. The percentage transmission of the acetone extracts of plant material is then compared with a calibration curve constructed from data obtained with solutions of purified chlorophyll.

This method eliminates the constant use of standard chlorophyll solutions and is not influenced by the presence of carotenoid pigments in the extract. Furthermore, it is unaffected by minor fluctuations in the light intensity, and errors involved in subjective intensity and color comparisons are avoided.



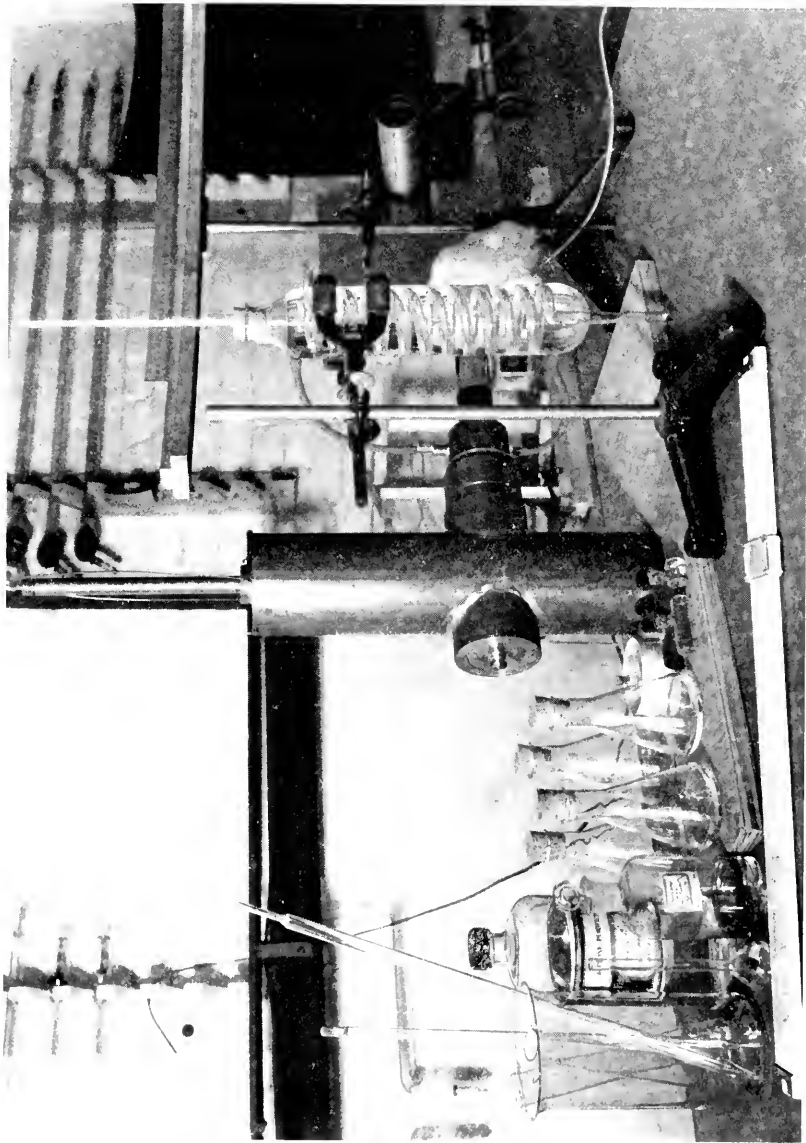

GENERAL VIEW OF APPARATUS USED FOR THE DETERMINATION OF SMALL AMOUNTS OF CHLOROPHYLL

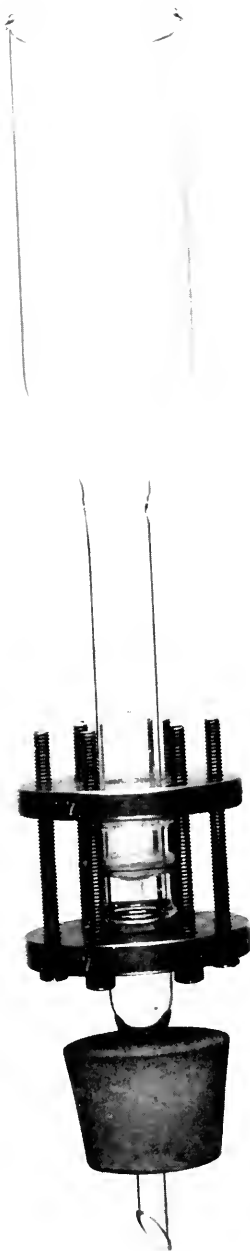

SPECIAL TYPE OF FILTER USED FOR REMOVAL OF SUSPENDED  
MATERIAL FROM CHLOROPHYLL SOLUTIONS  
(Over-all length, 20 cm.)



SMITHSONIAN MISCELLANEOUS COLLECTIONS

VOLUME 98 NUMBER 20

# THE HELT TOWNSHIP (INDIANA) METEORITE

(WITH NINE PLATES)

BY  
STUART H. PERRY  
Adrian, Mich.

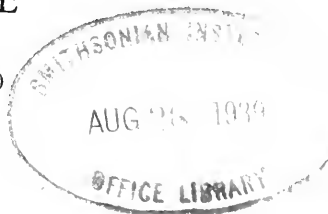

(PUBLICATION 3546)

CITY OF WASHINGTON  
PUBLISHED BY THE SMITHSONIAN INSTITUTION  
AUGUST 28, 1939

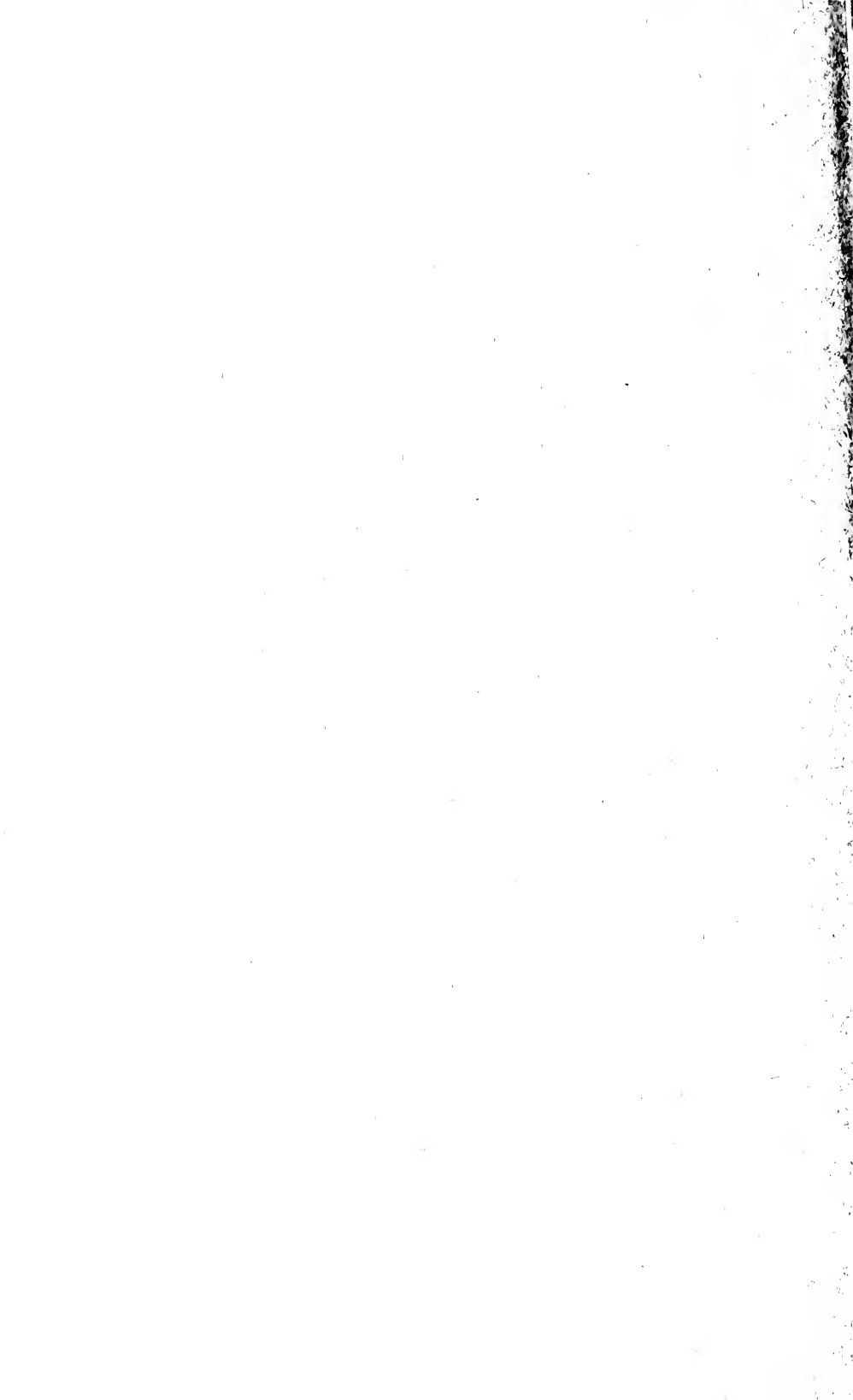

SMITHSONIAN MISCELLANEOUS COLLECTIONS  
VOLUME 98, NUMBER 20

THE HELT TOWNSHIP (INDIANA)  
METEORITE

(WITH NINE PLATES)

BY  
STUART H. PERRY  
Adrian, Mich.



(PUBLICATION 3546)

CITY OF WASHINGTON  
PUBLISHED BY THE SMITHSONIAN INSTITUTION  
AUGUST 28, 1939

The Lord Baltimore Press  
BALTIMORE, MD., U. S. A.

## THE HELT TOWNSHIP (INDIANA) METEORITE

BY STUART H. PERRY

*Adrian, Mich.*

(WITH NINE PLATES)

The Helt Township meteorite, a small but unusually interesting meteoric iron from Indiana, which has a fairly satisfactory history of having been observed to fall, was obtained by the writer in 1927 from William J. Seaver, a mineral dealer of Webster Groves, Mo. It was originally in the geological collection of the late John Collett, who was State Geologist of Indiana from 1878 to 1885, and who died in 1899.

Mr. Seaver stated that Dr. Collett at his death left a large collection of minerals and fossils at Terre Haute, where for many years they were stored in a cellar, suffering from loss and pilferage. All this material was bought by Mr. Seaver in 1915, and included in it was a collection of 13 small specimens of meteorites in a cabinet. Several years later, in a case of Indiana minerals and fossils, this additional specimen was discovered. When obtained by the writer it still bore a gummed label with the words "Vermillion County, Ind." in pencil. Dr. Collett may have kept it apart from the other meteorites because of a special interest in the specimen, arising from the fact that his home and birthplace were in that county, or perhaps because of the circumstances of its acquisition.

On the latter point definite information was furnished by the geologist's nephew, John S. Collett, of Indianapolis, who in 1929 wrote:

The meteorite now possessed by you was found in Vermillion county, in Helt township, by a farmer who saw it fall and heard the explosion as he was walking from his barn to his house between nine and ten o'clock in the evening. The next day he examined his fields and found a place of fresh earth that looked as if a small blast of explosive had been discharged—a sort of ragged opening like a small post-hole. Upon excavating he found the specimen you now possess, which was brought by the finder in person to the Professor at the State House in this city. The farmer's name as I remember it was Frist, the year about 1883 or 1884.

Correspondence with persons by the name of Frist in that township brought no information other than that they had heard that something had fallen in the neighborhood many years ago.

No further details could be furnished by Mr. Collett. His statement that the farmer "saw it fall" cannot be taken literally, for at that hour of the night he could not have seen it fall after it had ceased to be luminous; and if the appearance had been that of a fireball striking the earth, it actually would have struck many miles away. We may fairly assume, therefore, that it fell nearly vertically and that he saw the light and later heard a noise—perhaps not aptly described by the word "explosion." The hum or swish near the end of its flight perhaps was audible, and so gave him the impression of something falling nearby. At any rate, whatever he observed was such as to convince him that something had fallen and to prompt him to search for it the next morning.

The meager narrative of this occurrence is quite consistent with the supposition that this small iron fell in the manner above suggested. If any improbability attaches to that supposition, the coincidence of Frist seeing and hearing a meteor, believing it fell close to him, and actually finding an obviously freshly fallen meteorite the next day, would surely be much more improbable. The facts therefore seem to justify adding this to the short list of iron meteorites of which falls have been observed.

It is a flake-shaped mass, flat on one side and slightly convex on the other. It weighed when received 218.5 grams, having lost perhaps 10 or 15 grams when one side was polished by Dr. Collett. It was about 6 by 7 cm. in its larger dimensions and about 1.5 cm. in its greatest thickness.

The surface of the flat side which is covered by a very thin, slightly shining coating of magnetic oxide, shows no rust or abrasions and is characteristically pitted. At one edge a fine crack extends inward about 2 cm. from the edge on the flat side and a shorter distance on the rounded side, which undoubtedly resulted from stresses during its flight flatwise through the air. No evidence of drift is apparent on the fusion crust.

Most of the convex surface had been polished and etched by Dr. Collett, the polished surface following the original rounded contour (pl. 1, fig. 2). In order to provide an adequate surface for study, it was cut in a plane parallel with the flat side, whereby a slice about 5 mm. thick was removed and a surface about 4 by 5 cm. was obtained.

The structure is of the coarsest octahedral type (Ogg), the width of the bands ranging from 2 to 4 mm. They are slightly curved or wavy, of variable width, with irregularly rounded ends. The etched surface corresponds roughly with a cubic plane, and the kamacite bands run in

one general direction, with a few short ones at right angles and occasional rounded areas. Most of the bands have an oriented sheen, though not strongly marked; some show little or no variation as the direction of the light changes.

The meteorite consists almost entirely of kamacite, with few plessite fields, a sparing development of taenite, and numerous schreibersite inclusions. Generally, the kamacite bands are not separated by taenite lamellae, but only by invisible boundary lines along which contrasts of structure appear on etching. Often small bodies of schreibersite or of taenite, elongated and of various shapes, appear along such boundaries, but such inclusions are rarely continuous for more than short distances.

Near one corner of the polished surface is an area about 2 cm. square which shows no definite figures. In this area the taenite is in short thin lines, or occasional baguettes or irregular shapes, with one sprangling inclusion about 2 by 5 mm. in size.

Plessite fields are few, consisting mostly of eutectiform areas of taenite lamellae of the type shown in plate 2, figure 1, termed "perlitoid" by some of the German writers. Other areas are filled with coarse oriented skeletal growths (pl. 2, fig. 2; pl. 3). No fields filled with fine taenite particles or threads, nor areas of dark (micro) plessite, were observed.

Plate 5 shows a taenite lamella with breaks suggesting the appearance of faulted rock strata, a result of local deformation. Similar but less conspicuous displacements are observable in other spots (pl. 8, fig. 1). Such displacements always coincide with Neumann lines, and in the area shown in plate 5 a considerable movement took place along the gliding planes marked by some of the lines.

Neumann lines are caused by shock or quick stress, and it has been suggested by various writers that they may have been produced when a mass of meteoric iron struck the earth. In the present case it is clear that the disturbance that produced the displacements (and simultaneously the Neumann lines) must have occurred before the mass reached the earth, and prior to the partial alteration of structure produced by reheating during flight, which in places obliterated the Neumann lines. The shock of the impact of such a small mass upon soft earth would be comparatively slight; but the violent stresses resulting from atmospheric pressure during flight (sufficient often to cause cracks in iron meteorites, and sometimes disruption) would readily account for evidences of deformation, ranging all the way from light Neumann lines to pronounced displacements of structure.

It is to be noted that the granular border or aureole which developed around all inclusions after the formation of the Neumann lines follows the irregularities of the taenite, but the grain boundaries give no evidence of mechanical deformation.

In the Tamarugal (El Inca) iron the fracture of a troilite nodule and the displacement of the broken halves are described and illustrated by Rinne and Boeke.<sup>1</sup> Fractures and displacements in schreibersite inclusions have also been observed by Brezina in the Puquios iron, and by Cohen in that of Chesterville.

Schreibersite and taenite inclusions of similar form are often juxtaposed, or alternate with one another along band boundaries, and the two substances are so nearly identical in appearance that they are not easily distinguished except by selective etching (pl. 4) or by a hardness test.

Numerous schreibersite inclusions, which with ordinary etching appear clear and featureless, reveal a highly developed eutectic structure when etched lightly with sodium picrate (pl. 6). The etching must stop at exactly the proper stage, for a few additional minutes will cause the structure to disappear in a uniform black.

The anomalous structure shown in plate 9 is apparently an area of phosphorus enrichment in kamacite. Except for the peculiar eutectoid appearance the kamacite is little changed, Neumann lines and rhabdites appearing within the area. The rhabdites, it will be noted, are surrounded by phosphorus-poor aureoles, both within and without the area.

Schreibersite in the form of rhabdite is abundantly disseminated through the mass in squares, rectangles, and rhombs, diversely oriented, as shown in plate 9 and plate 8, figure 2. In the latter figure the rhabdites are surrounded by black borders—an optical effect due to the fact that, because of their hardness, polishing left them slightly in relief and thus the light is reflected away from the iron immediately surrounding them.

Two or three minute grains of chromite were observed, but no troilite.

Neumann lines are conspicuous, often running uninterruptedly across several bands with no change, or slight change, of direction at the boundaries.

Superficial heating during flight apparently caused partial or incipient alteration of the kamacite almost throughout the mass by the for-

<sup>1</sup> El Inca, ein neues Meteoreisen. Neues Jahrb. Min., Geol., Pal., Festband 1907, pp. 227-255.



mation of granulated areas in which the Neumann lines are partly or wholly obliterated. In the central part of the polished surface these areas are surrounded by unaltered kamacite in which the lines show no change, but near the edges the alteration is uniform.

Experiments by several investigators referred to by the writer in "The San Francisco Mountains Meteorite,"<sup>2</sup> have established that kamacite is completely altered by heating for the equivalent of about 1,000° for 1 or 2 seconds. In this case the incomplete alteration indicates a minimum degree of heating—probably brief and not far above the alpha-gamma inversion, which for kamacite (with rising temperature) would be about 700°.

Incipient alteration is observable around all inclusions. Wherever taenite or schreibersite appears it is surrounded by granulations. They also appear in stringlike form along the invisible, or barely visible, lines connecting such inclusions (pl. 8, fig. 1), and along the boundaries of kamacite bands where no taenite is visible. In such places a plane of nickel or phosphorus enrichment, although not producing a visible line on the etched surface, was evidently sufficient to initiate the process of recrystallization.

In the aureoles surrounding rhabdite crystals (pl. 8, fig. 2) the grains are noticeably lighter and more homogeneous than the surrounding unaltered kamacite, which is more or less darkened by a profusion of extremely minute particles.

Assuming that such minute particles consist of phosphide, its migration to the rhabdite could account for such a clearing up of the adjacent newly formed grains. Because of the lower melting point of the phosphide the alteration of the kamacite started at the rhabdite crystals, and as it proceeded outward, the newly formed grains gave up their phosphide and became practically pure kamacite. As such migration would take place far below the melting point of kamacite, the process would be relatively slow and could extend only a short distance during the brief period of heating. That the same process should take place around taenite inclusions is not inconsistent, because taenite probably always contains some phosphide and is often distinctly bordered with it, as sodium picrate etching reveals. Plate 4 shows a phosphide eutectoid area in taenite.

Vogel<sup>3</sup> holds that the larger crystals and masses of schreibersite

<sup>2</sup> The San Francisco Mountains Meteorite. *Amer. Journ. Sci.*, vol. 28, p. 216, Sept. 1934.

<sup>3</sup> Eine umfassendere Deutung der Gefügeerscheinungen des Meteoreisens . . . *Abh. Ges. Wiss. Göttingen, Math.-Phys. Klasse, III Folge, Heft 6, 1932.*

Über die Strukturformen des Meteoreisens . . . *Ibid.*, Neue Folge, Band XII, 2, 1927.

originate in the melted stage, citing the fact that they are often surrounded by a granular area corresponding with a phosphorus-poor zone, which would indicate a rapid separation of the schreibersite as the cooling progressed; but that nevertheless such areas can arise from incipient solution of the crystals in a solid state, which process with a rising temperature in an alloy of the composition of kamacite would begin at around  $700^{\circ}$ . The temperature named by Vogel is the alpha-gamma inversion point on heating; on cooling that point would be about  $200^{\circ}$  lower, so the process would be correspondingly prolonged.

Either of Vogel's explanations of the origin of such granular kamacite areas involves phosphorus impoverishment near the schreibersite masses. In the present instance, since the alteration which produced the new grain boundaries was the result of reheating after the Neumann lines were formed, it is possible that the migration of phosphide from the surrounding kamacite accompanied the formation of the grains.

An interesting analogy is presented by the process of recrystallization in cast iron, as shown by a sample that had been subjected to more and more extended annealing at a temperature of about  $800^{\circ}$ . Graphite nuclei grew by accretion, carbon being absorbed from the cementite in the surrounding areas, until finally granulation was complete, the graphite nuclei had absorbed all the carbon, and the ground mass consisted of grains of pure ferrite. The later stages of the process produced granulated aureoles around the graphite nuclei much resembling those surrounding the rhabdites in the iron here described.

The more remote the rhabdite crystals are from the surface of the mass, the less granulation appears around them. The surface left after removing the slice, which is perhaps half an inch below the highest part of the original surface of the mass, shows in its central portions many rhabdite crystals with little or no surrounding granulation.

Plate 7, figure 1, shows a very minute schreibersite inclusion of unusual character, its edges having a prickly appearance due to a slight extension of phosphide into the surrounding iron at grain boundaries. The phosphide also appears segregated along certain grain boundaries at some distance from the inclusion.

This inclusion is close to the surface of the mass, where the effect of the temporary reheating during flight was greatest, and the invasion of the iron by the phosphide at grain boundaries is obviously due to a brief melting of the schreibersite. As its melting point is below  $1,000^{\circ}$ , a reheating sufficient to produce granulation in the kamacite would also be sufficient for such fusion. Slight traces of a

similar incipient diffusion may be seen in plate 6, figure 2. Schreibersite inclusions presenting exactly the same appearance are observable in hexahedrites and nickel-poor ataxites that have been altered by reheating.

Plate 7, figure 2, shows a larger schreibersite inclusion close to the edge of the slice, which after fusion solidified with a eutectoid structure. While liquefied it dissolved some of the surrounding iron, which later separated in minute droplike particles.

At one point at the edge of the polished slice melted magnetic oxide, produced superficially during flight, has invaded the mass slightly. One of the larger schreibersite masses enveloped in the oxide is scarcely altered, but one or two rhabdite crystals were observed to have become rounded into droplike form.

Because of the small size of this iron, no analysis was made. Its structure would indicate approximately the usual nickel content of coarsest octahedrites, a substantial amount of phosphorus, and little or no sulphur.

The name Helt Township is chosen for this meteorite, the main part of which has lately been given by the writer to the United States National Museum. It is the ninth meteorite, and the fourth siderite reported from Indiana.





1. FLAT SIDE OF HELT METEORITE  
About natural size.

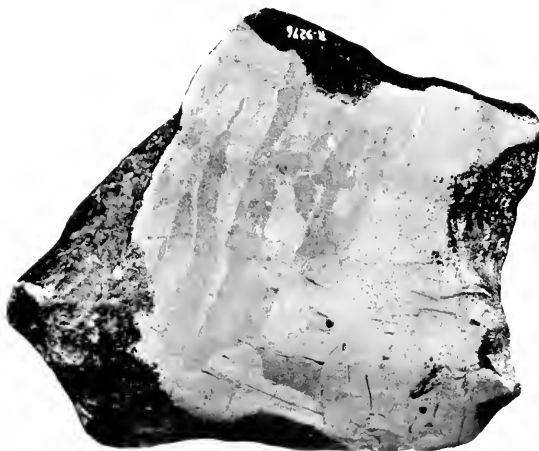

2. ROUNDED SIDE OF HELT METEORITE  
Partly polished and etched.

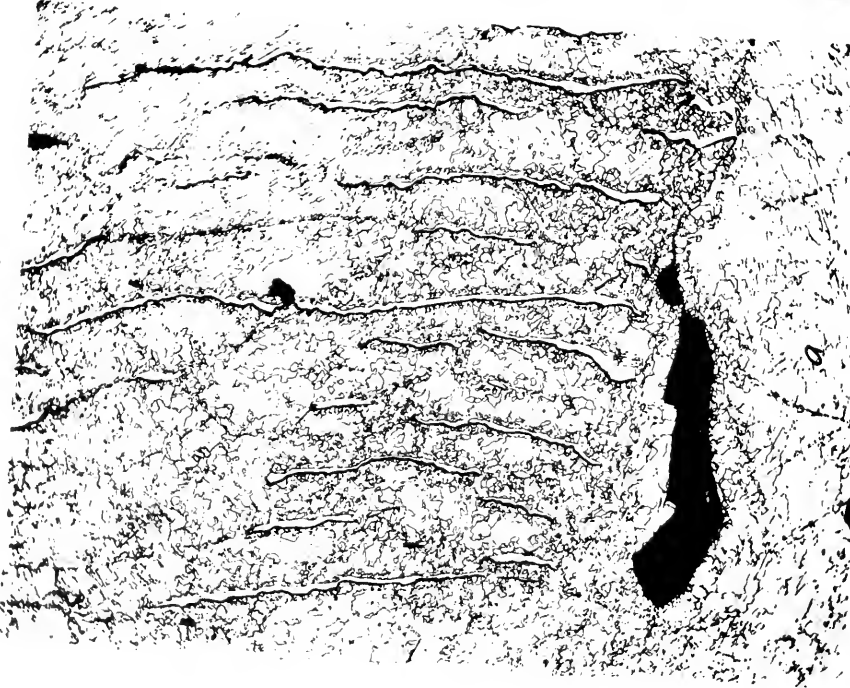

1. COARSE EUTECTIFORM ("PERLITOID") PLESSITE FIELD:  
SCHREIBERSITE APPEARS BLACK  
Picral and 10 minutes sodium picrate, x 100.

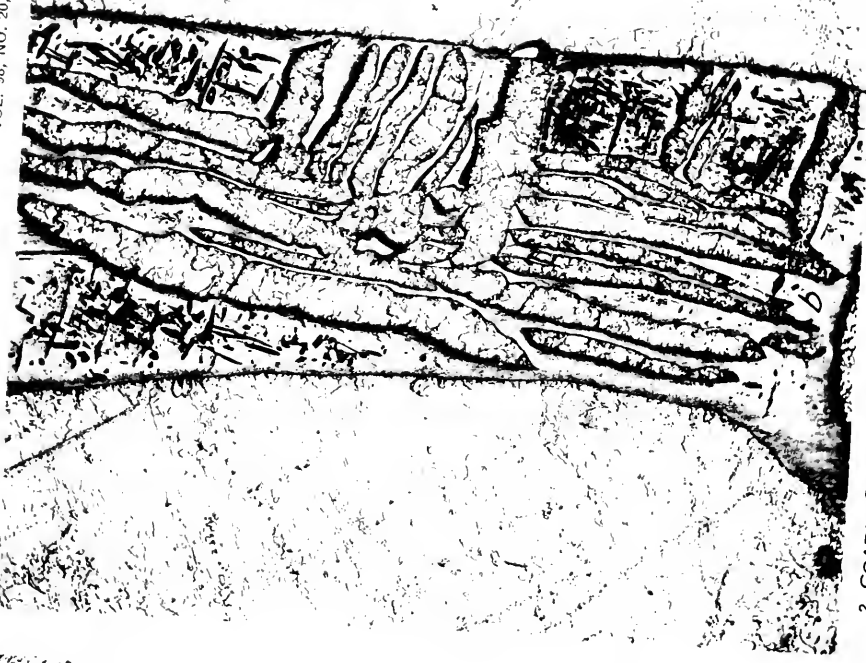

2. COARSE SKELETAL GROWTH OF TAENITE, ENCLOSING  
EUTECTOID PHOSPHIDE AREAS  
Picral, x 100.

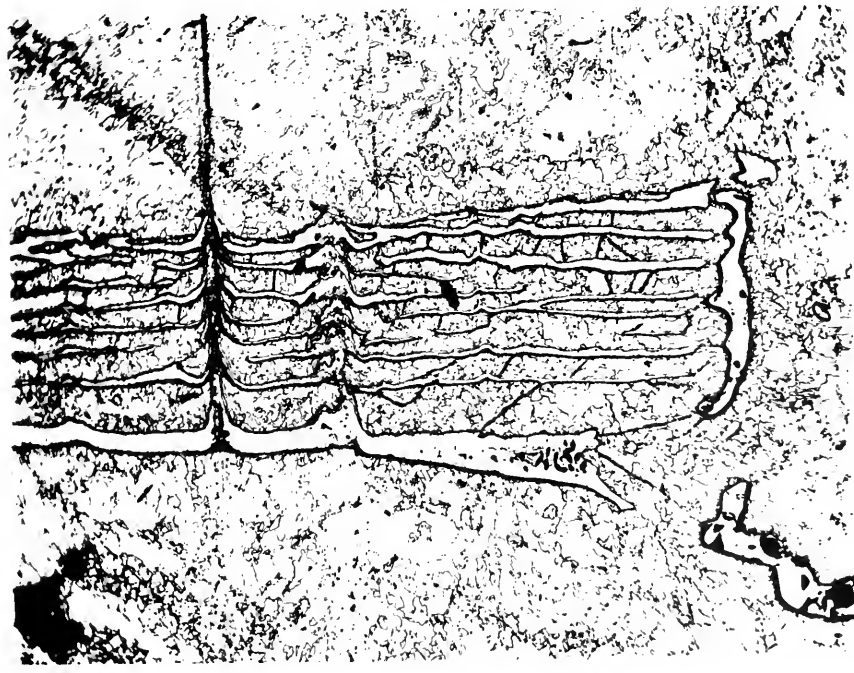

1. SKELETAL GROWTH OF TAENITE. THE IRREGULAR INCLUSIONS AT BOTTOM AND AT LOWER LEFT CORNER ARE SCHREIBERSITE  
Pictal, x 100.

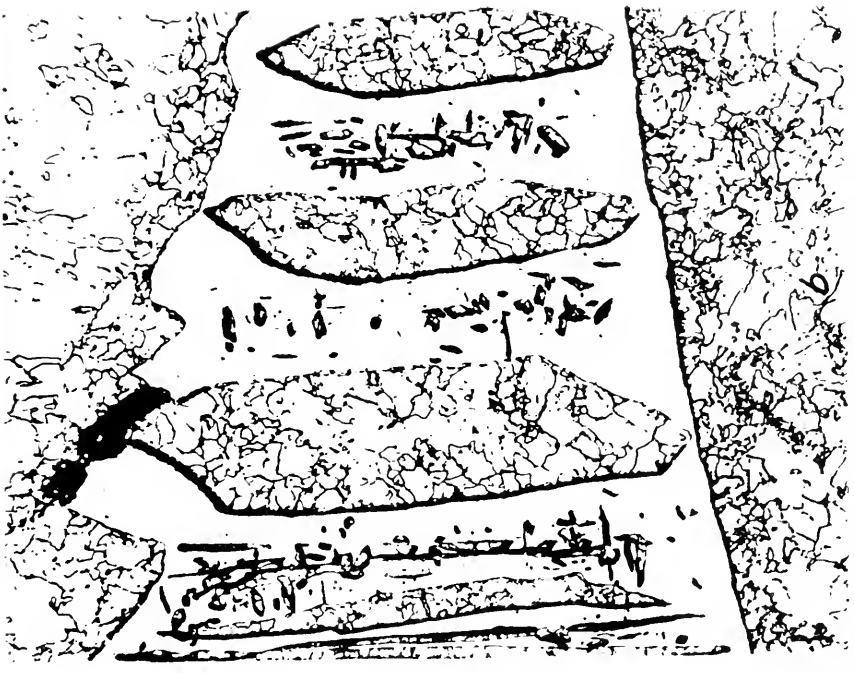

2. SKELETAL GROWTH OF TAENITE ENCLOSED EUTECTOID PHOSPHIDE. PORTION OF A LARGER AREA  
Pictal and 10 minutes sodium pictrate, x 250.



1. WEDGE-SHAPED END OF TAENITE LAMELLA ENCLOSING  
EUTECTOID PHOSPHIDE AREA  
Picral, x 100.



2. THE AREA SHOWN IN FIGURE 1  
Sodium picrate, x 100.





1. DISPLACED TAENITE LAMELLA  
Picral, x 100.

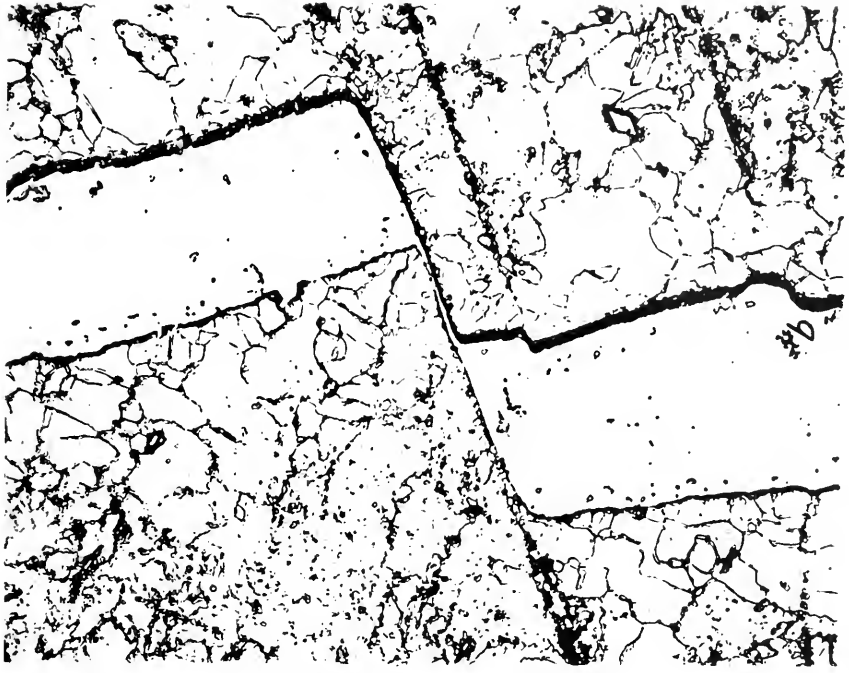

2. PART OF AREA SHOWN IN FIGURE 1  
x 500.

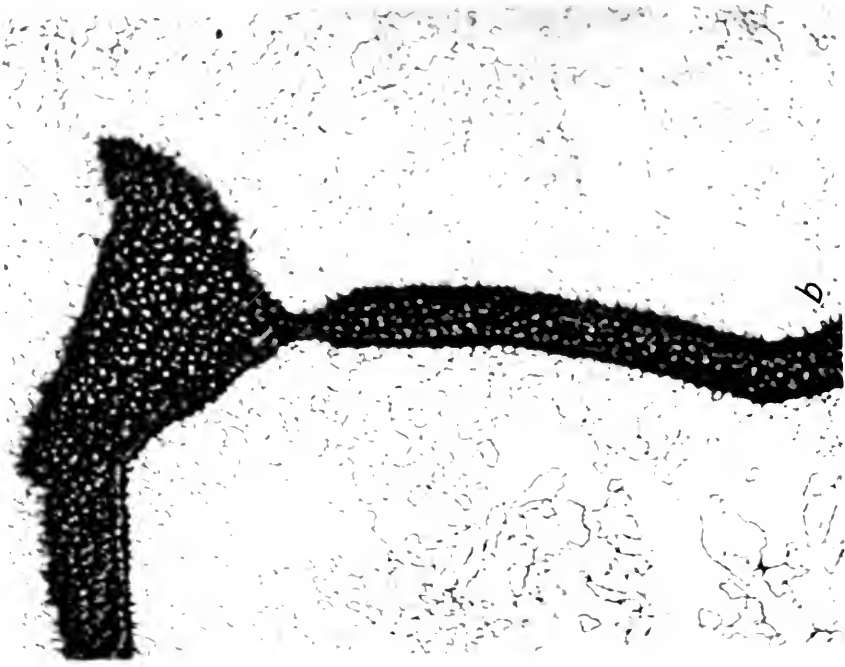

2. AN AREA SIMILAR TO FIGURE 1  
Picral and 15 minutes sodium picrate, x 250.

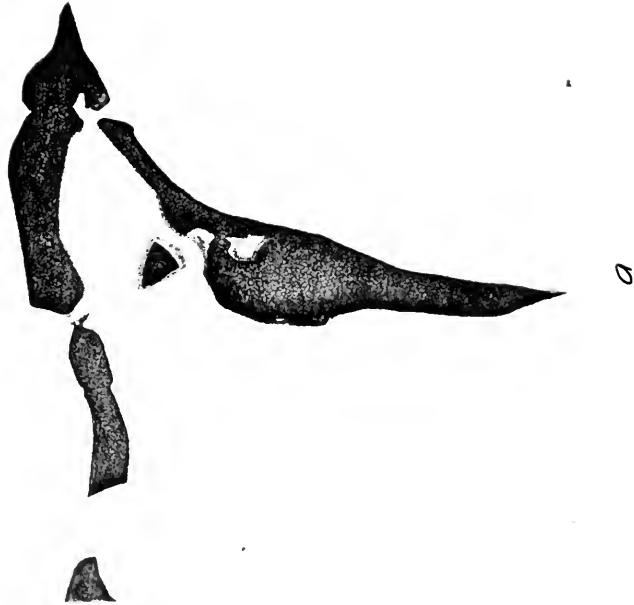

1. EUTECTIC STRUCTURE IN SCHREIBERSITE  
Sodium picrate 10 minutes, x 100.

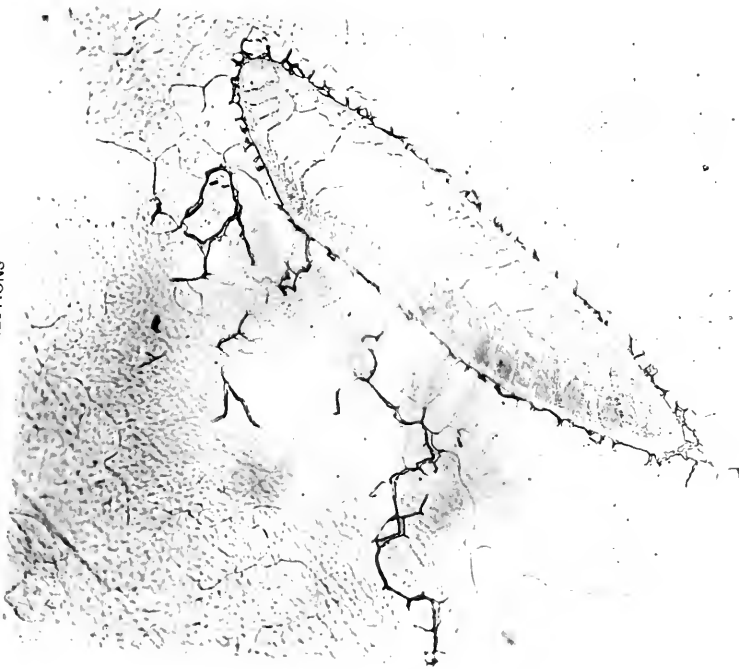

a

1. SCHREIBERSITE INCLUSION  
Picral, x 500.

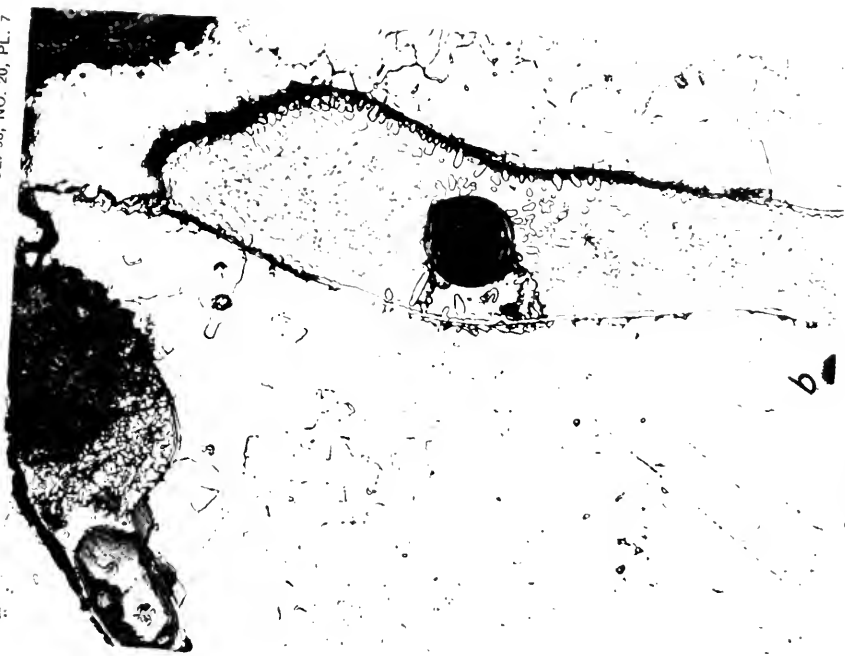

b

2. SCHREIBERSITE INCLUSION  
Picral, x 250. The round black spot is a glassy bleb.

SMITHSONIAN MISCELLANEOUS COLLECTIONS

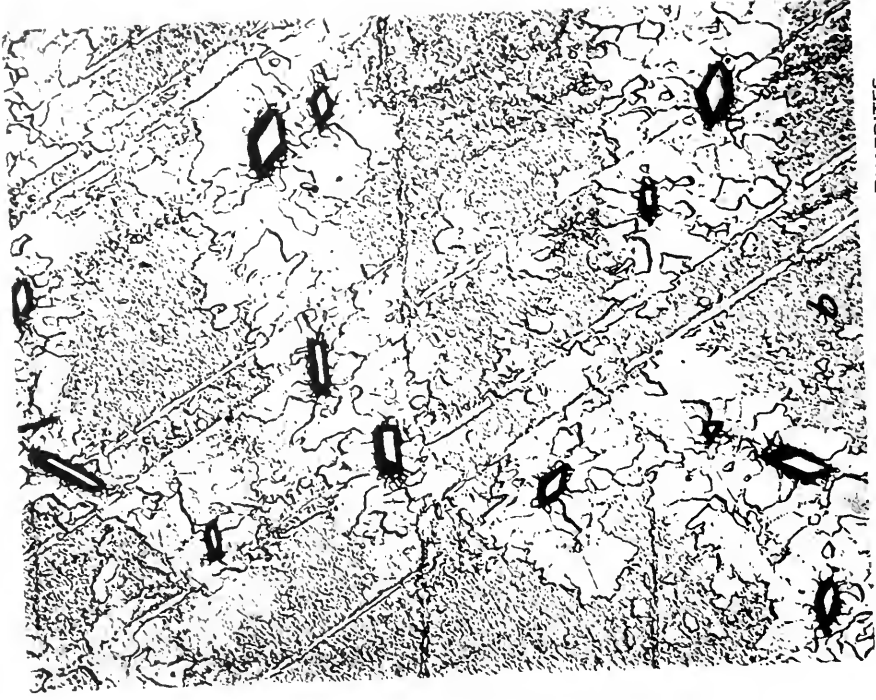

2. INCIPIENT GRANULATION AROUND RHABDITES  
Picral, x 200.



1. GRANULATION IN KAMACITE ALONG LINE CONNECTING  
TWO SCHREIBERSITE INCLUSIONS.

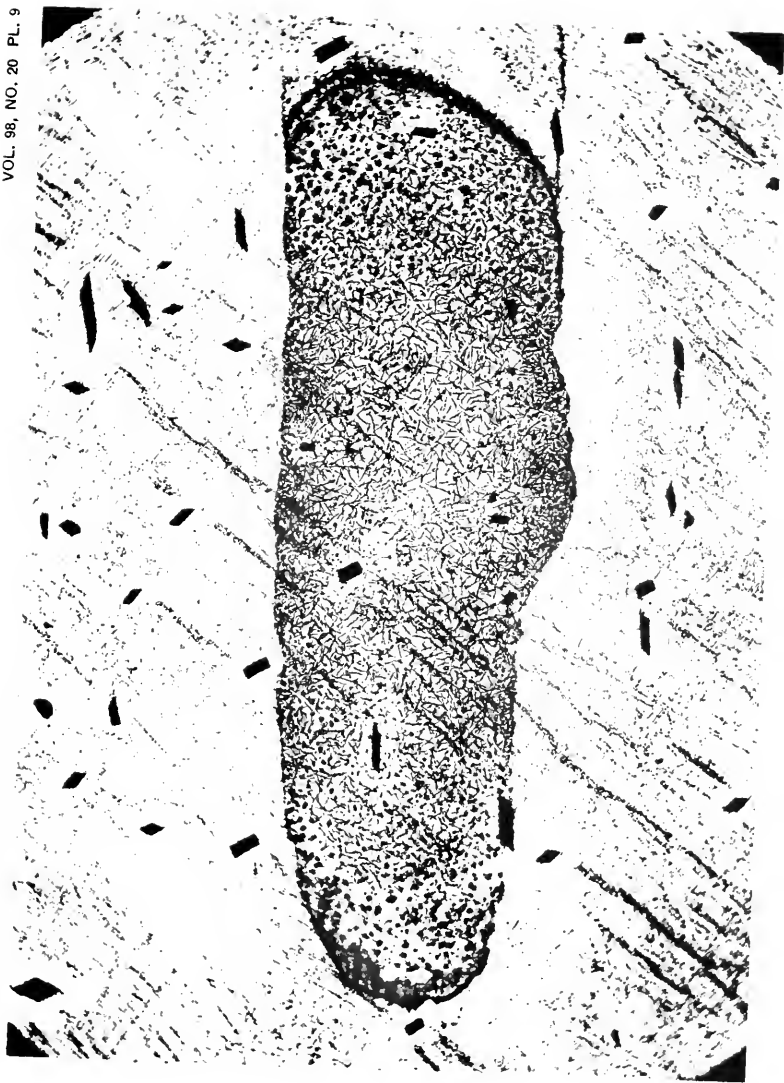

AREA OF PHOSPHORUS ENRICHMENT IN KAMACITE  
Sodium picrate 7 minutes and picral 10 seconds, x 100.



SMITHSONIAN MISCELLANEOUS COLLECTIONS  
VOLUME 98, NUMBER 21

Roebling Fund 1939



# THE WEEKLY PERIOD IN WASHINGTON PRECIPITATION

BY

C. G. ABBOT

AND

N. M. McGANDLISH

Smithsonian Institution



(PUBLICATION 3547)

CITY OF WASHINGTON  
PUBLISHED BY THE SMITHSONIAN INSTITUTION  
JULY 27, 1939





SMITHSONIAN MISCELLANEOUS COLLECTIONS

VOLUME 96, NUMBER 21

---

## Roebliug Fund

---

# THE WEEKLY PERIOD IN WASHINGTON PRECIPITATION

BY

C. G. ABBOT

AND

N. M. McGANDLISH

Smithsonian Institution



(PUBLICATION 3547)

CITY OF WASHINGTON  
PUBLISHED BY THE SMITHSONIAN INSTITUTION  
JULY 27, 1939

The Lord Baltimore Press  
BALTIMORE, MD., U. S. A.

# Roebling fund

## THE WEEKLY PERIOD IN WASHINGTON PRECIPITATION

By C. G. ABBOT AND N. M. McCANDLISH  
*Smithsonian Institution*

Golf and tennis players working in Washington, D. C., are sometimes disappointed by a succession of rainy Saturday afternoons. So insistently has this forced itself on our attention that we have examined the daily weather record at Washington for the years 1924 to 1939 to see if there is any real ground for supposing that there is a marked period of seven days in precipitation.

Other researches of this Institution have indicated that variations of the sun are important causes of weather changes. As the sun's rotation period is slightly less than 4 weeks, we were inclined to suppose that a period of one-fourth that of solar rotation or slightly less than 1 week, if found in weather, might be associated with the sun's rotation. If it were really caused by a solar variation, and related to the sun's rotation, then the weekly weather period, while nearly constant in length, would probably shift in phase occasionally. For it is well known that solar features, such as sunspots, while they may be nearly fixed on the sun's surface for several rotations, soon disappear and are succeeded by others at other solar longitudes.

Statistics soon persuaded us that, so far as there is evidence for this nearly weekly weather period, it seemed indeed to be a little less than 7 days. As a first approximation we assumed that the day of maximum precipitation shifts 1 day earlier in the week on each successive month. As a rough and ready index of precipitation we computed for each month separately the percentages of the total monthly precipitation which fell on the seven successive days of the week, Sunday to Saturday. We arranged these monthly percentages in a table in which the week-day names shifted to the left by 1 day each month.

Taking sums of the seven columns of our table we were then in a position to see whether the day of maximum precipitation did actually remain in the same column, or nearly so, for long intervals. To illustrate these procedures we give tables 1 and 2.

As is apparent from table 2, the same column contains the day of maximum precipitation for the yearly average for 4 successive years.

from 1926 to 1929 inclusive. The columns of maximum precipitation in 1924 and 1925 are shifted from this prevailing place only two columns and one column later than this in the week, respectively. In 1930 the highest maximum occurs several days later in the week, but a maximum only a very little lower than this occurs in the same column as for 1925. In 1931 the position of maximum returns to the column frequented from 1926 to 1929.

TABLE 1—Percentages of Monthly Total Precipitation Falling on Successive Days of the Week, 1929

Month	Day of the week at percentage precipitation						
	Wed.	Thur.	Fri.	Sat.	Sun.	Mon.	Tues.
Jan.	2	18	30	32	6	0	12
Feb.	10	35	51	0	3	0	1
Mar.	16	43	7	0	0	34	0
Apr.	34	10	38	1	14	3	0
May.	0	29	29	8	19	13	2
June.	26	27	2	20	15	9	1
July.	0	30	0	0	63	0	7
Aug.	0	15	15	65	0	0	4
Sept.	38	0	25	0	14	19	5
Oct.	0	59	40	0	1	0	0
Nov.	40	36	0	7	5	5	7
Dec.	4	4	55	0	27	6	4
Sum. year.	170	306	292	133	167	89	43
Percent, year.	14	26	24	11	14	7	4

If, as suggested above, the cause of the weekly weather period is associated with solar rotation, and if the period is constant while the phase is subject to changes as features form and disappear on the sun, then there is no reason to expect the interval which we term the year to have any special relationship with the persistence of any particular phase. Accordingly we have sought to make a better arrangement by comparing from month to month the distribution of percentages of precipitation falling on the dates I to VII of table 2.

This study led to the arrangement shown in table 3, where sums are given of the monthly percentages in the dates I to VII through the intervals indicated. Maxima are printed in bold-face type, minima in italics.

TABLE 2—Yearly Sums of Monthly Percentages of Total Precipitation Falling on Successive Days of the Week, 1924-1939

Year	Successive Days						
	I	II	III	IV	V	VI	VII
1924.....	142	166	183	260	193	98	60
1925.....	198	75	248	205	100	231	142
1926.....	211	276	147	160	104	144	157
1927.....	105	322	118	167	131	140	217
1928.....	95	237	167	228	113	221	139
1929.....	170	306	292	133	167	89	43
1930.....	151	51	314	105	86	344	150
1931.....	193	243	161	96	183	106	224
1932.....	257	236	131	225	147	99	107
1933.....	154	127	169	168	107	178	297
1934.....	229	177	280	103	91	137	182
1935.....	126	101	232	334	181	103	124
1936.....	171	251	215	153	290	89	35
1937.....	137	88	161	186	237	226	165
1938.....	162	154	122	240	115	239	160
1939.....	50	124	25	105	93	48	66
Totals.....	2,551	2,934	2,965	2,868	2,338	2,492	2,268

TABLE 3

Interval	I	II	III	IV	V	VI	VII
Jan. 1924-Oct. 1924.....	103	157	71	<b>252</b>	190	73	55
Nov. 1924-Sept. 1925.....	203	<i>46</i>	<b>342</b>	196	74	135	105
Oct. 1925-Nov. 1927.....	349	<b>632</b>	279	305	<i>258</i>	361	415
Dec. 1927-Oct. 1928.....	<i>64</i>	148	148	231	112	<b>258</b>	138
Nov. 1928-Dec. 1929.....	202	<b>399</b>	315	169	174	96	45
Jan. 1930-Mar. 1931.....	165	196	<b>402</b>	141	<i>92</i>	351	155
Apr. 1931-Dec. 1931.....	179	98	73	<i>60</i>	177	99	<b>219</b>
Jan. 1932-Nov. 1932.....	<b>257</b>	193	128	225	129	<i>63</i>	107
Dec. 1932-Nov. 1933.....	149	165	132	<i>125</i>	<i>125</i>	214	<b>290</b>
Dec. 1933-Mar. 1935.....	265	232	<b>416</b>	203	<i>115</i>	156	214
Apr. 1935-Dec. 1935.....	95	<i>51</i>	136	<b>277</b>	157	84	99
Jan. 1936-Dec. 1936.....	171	251	215	153	<b>290</b>	89	35
Jan. 1937-June 1937.....	<i>38</i>	57	40	93	133	<b>154</b>	85
July 1937-Dec. 1937.....	99	<i>31</i>	<b>121</b>	93	104	72	80
Jan. 1938-May 1939.....	212	278	<i>147</i>	<b>345</b>	208	287	226

By reduction of table 3 to percentages there results table 4.

From table 4 we conclude that, assuming a periodicity of 6 days 18 hours in precipitation at Washington, a day of maximum precipi-

tation persists in the averages for many months, on which day from 2 to 8 times as much precipitation falls as on neighboring days of minimum precipitation usually 1 day earlier and 2 days later. At intervals ranging from 40 to 100 weeks the day of maximum precipitation shifts a little within the period, and at times, though rarely, a pronounced double maximum persists.

TABLE 4—*Percentages of Precipitation on Selected Days*

Interval	I	II	III	IV	V	VI	VII	Total	$\frac{\text{Max.}}{\text{Min.}}$
Jan. 1924–Oct. 1924 . . .	11.4	17.4	7.9	<b>28.0</b>	21.1	8.1	6.1	100	4.6
Nov. 1924–Sept. 1925 . . .	18.4	4.2	<b>31.1</b>	17.8	6.7	12.3	9.5	100	7.4
Oct. 1925–Nov. 1927 . . .	13.4	<b>24.3</b>	10.7	11.7	9.0	13.9	16.0	100	2.5
Dec. 1927–Oct. 1928 . . .	5.8	13.5	13.5	21.0	10.2	<b>23.5</b>	12.6	100	4.0
Nov. 1928–Dec. 1929 . . .	14.4	<b>28.5</b>	22.5	12.1	12.4	6.9	3.2	100	8.9
Jan. 1930–Mar. 1931 . . .	11.0	13.0	<b>26.8</b>	9.4	6.1	23.4	10.3	100	4.4
Apr. 1931–Dec. 1931 . . .	19.8	10.8	8.1	6.6	19.6	10.9	<b>24.2</b>	100	3.7
Jan. 1932–Nov. 1932 . . .	<b>23.3</b>	17.5	11.6	20.4	11.7	5.7	9.7	100	4.1
Dec. 1932–Nov. 1933 . . .	12.4	13.8	11.0	10.4	10.4	17.8	<b>24.2</b>	100	2.3
Dec. 1933–Mar. 1935 . . .	16.6	14.5	<b>26.0</b>	12.7	7.2	9.7	13.4	100	3.6
Apr. 1935–Dec. 1935 . . .	10.6	5.7	15.1	<b>30.8</b>	17.5	9.3	11.0	100	5.4
Jan. 1936–Dec. 1936 . . .	14.2	20.8	17.9	12.7	<b>24.1</b>	7.4	2.9	100	8.3
Jan. 1937–June 1937 . . .	6.3	9.5	6.7	15.5	22.2	<b>25.7</b>	14.2	100	4.1
July 1937–Dec. 1937 . . .	16.5	5.2	<b>20.2</b>	15.5	17.3	12.0	13.3	100	3.9
Jan. 1938–May 1939 . . .	12.4	16.3	8.6	<b>20.3</b>	12.2	16.9	13.3	100	2.4

In May 1939, an exceptionally dry month, maxima of precipitation occurred on Saturday and Monday. According to table 4 maximum precipitation should have occurred between them on Sunday. In reality zero precipitation occurred on Sunday, Wednesday, Thursday, and Friday. If we use the average position of maxima and minima in the interval from January 1938 to the present time, the maxima for June 1939 should fall on Sunday and Tuesday, the minimum on Saturday, and these features should come 1 day earlier in the week successively in subsequent months.

SMITHSONIAN MISCELLANEOUS COLLECTIONS

VOLUME 98, NUMBER 22

BIRDS FROM CLIPPERTON ISLAND  
COLLECTED ON THE PRESIDENTIAL  
CRUISE OF 1938

BY  
ALEXANDER WETMORE  
Assistant Secretary  
Smithsonian Institution

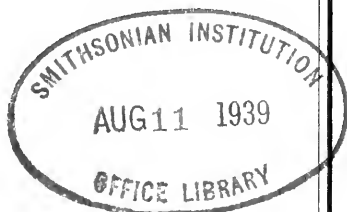

(PUBLICATION 3548)

GITY OF WASHINGTON  
PUBLISHED BY THE SMITHSONIAN INSTITUTION  
AUGUST 11, 1939





SMITHSONIAN MISCELLANEOUS COLLECTIONS

VOLUME 98, NUMBER 22

BIRDS FROM CLIPPERTON ISLAND  
COLLECTED ON THE PRESIDENTIAL  
CRUISE OF 1938

BY

ALEXANDER WETMORE

Assistant Secretary  
Smithsonian Institution



(PUBLICATION 3548)

CITY OF WASHINGTON  
PUBLISHED BY THE SMITHSONIAN INSTITUTION  
AUGUST 11, 1939

**The Lord Baltimore Press**  
BALTIMORE, MD., U. S. A.

# BIRDS FROM CLIPPERTON ISLAND COLLECTED ON THE PRESIDENTIAL CRUISE OF 1938

BY ALEXANDER WETMORE  
*Assistant Secretary, Smithsonian Institution*

Clipperton Island, the most eastern atoll in the Pacific Ocean, like most uninhabited tropical islands of its type, is the home of large numbers of sea birds, but not until the Presidential Cruise of 1938 did the National Museum have the opportunity of obtaining certain desirable specimens of its avifauna.

A party from the U. S. S. *Houston* landed on Clipperton for shore collecting on July 21, when, through the active interest of Lt. Comdr. T. J. Kelly of the vessel, and Michael Reilly, of the President's personal staff, a series of 34 birds was obtained.

On leaving the island it was necessary, because of rough water, to carry the specimens out through the surf in a burlap sack. On ship-board they were wrapped in cheesecloth and then frozen. Held in this condition until the conclusion of the cruise, they were then packed in dry ice, shipped to Washington from Pensacola, and placed in cold storage until made up in the taxidermy shop of the Museum. Thus handled the specimens came through in first-class condition and yielded excellent study skins.

Following are notes on the species obtained:<sup>1</sup>

## Family SULIDAE

### **SULA LEUCOGASTER NESIOTES** Heller and Snodgrass

#### CLIPPERTON ISLAND BOOBY

*Sula nesiotes* HELLER and SNODGRASS, Condor, vol. 3, May 1901, p. 75 (Clipperton Island).

Five adult males, two adult females, an immature male and three young of assorted size in the down constitute an excellent series of this bird, the first from this locality to come to the National Museum. These skins are important in indicating that the Clipperton bird, currently considered identical with *Sula leucogaster brewsteri* of Baja

<sup>1</sup>For a list of the birds of Clipperton Island see Snodgrass, R. E., and Heller, E., Proc. Washington Acad. Sci., vol. 4, Sept. 30, 1902, pp. 501-520.

California, is distinct and to be recognized as a separate geographic race under the name *nesiotes* given it years ago by Heller and Snodgrass.

The identification of these birds from Clipperton Island has led to examination of all the boobies of this group from the west coast of the New World from Baja California to Gorgona Island, Colombia, with results that are of interest. While apparently uniform over large areas of the tropical oceans of other parts of the world there are three (barely possibly four) races of *Sula leucogaster* to be recognized in the limited area on the Pacific coast of the Americas under consideration. These differ from all other subspecies of the species in question in having the head in the male in part, or entirely, distinctly lighter than the neck and upper parts. Following are notes on these races:

*Sula leucogaster brewsteri* Goss:

*Sula brewsteri* Goss, Auk, 1888, p. 242 (San Pedro Martir Island, Gulf of California).

Male with the head partly light in color, the paler area confined mainly to the face; female with upper surface, head, and neck brownish (uniform in shade like *S. l. plotus* of widespread distribution farther west in the Pacific but lighter colored).

*Range*.—Baja California, including the Gulf of California, to the Revillagigedo Islands.

*Measurements* (in millimeters).—Males (6 specimens), wing 375-397 (384), tail 178-196 (187), culmen from base 90-95.3 (93.2), depth of bill at gonydeal angle 11.0-13.6 (12.4), tarsus 46.5-52.1 (48.5), middle toe with claw 76.9-78.8 (78.0).

Females (7 specimens), wing 389-414 (403), tail 176-198 (189), culmen from base 93.7-104 (98.4), depth of bill at gonydeal angle 12.5-14.7 (13.2), tarsus 48.5-54 (51.5), middle toe with claw 76.9-78.8 (78).

In these measurements there are included data from three specimens in the Carnegie Museum from San Benedicto, Revillagigedo Islands, made available to me by A. J. van Rossem. In comparing the measurements of *brewsteri* and the other races here discussed the length of the tail is included but has not been considered in comparative studies of size as the rectrices in these boobies are often subject to much abrasion, depending probably upon the conditions under which the bird habitually perches, whether on sand or rock.

*Sula leucogaster nesiotes* Heller and Snodgrass:

*Sula nesiotes* HELLER and SNODGRASS, Condor, vol. 3, May 1901, p. 75 (Clipperton Island).

Male with the head and neck much lighter than *brexesteri* or *etsiaca*, the head in fully adult birds being almost white; back and breast more grayish, less brownish. Female with upper surface, foreneck, and breast darker, more sooty gray, less brownish than *brexesteri* or *etsiaca*.

*Range*.—Clipperton Island, considered to range also to the Tres Marias and Isabel Island, western Mexico; a specimen assigned here seen also from Manzanillo, Colima.

*Measurements* (in millimeters).—(All specimens from Clipperton Island, the type locality): Males (11 specimens), wing 360-385 (376), tail 166-205 (188), culmen from base 90.2-97.3 (93.5), depth of bill at gonydeal angle 11.7-14.1 (12.9), tarsus 44.3-49.2 (46.7), middle toe and claw 72.0-77.9 (76.3).

Females (7 specimens), wing 385-410 (400), tail 163-200 (178), culmen from base 97.6-100.8 (99.2), depth of bill at gonydeal angle 13.7-15.7 (14.6), tarsus 47.1-51 (49.2), middle toe and claw 79.0-86.8 (82.6).

The extent of the light color on the head and neck of the male in this race, and the darker, less brownish cast of the female, set this group of birds off strikingly from *brexesteri* to the north and *etsiaca* to the south, and the light color of the head that appears in males of these boobies on the Pacific coast of the New World and nowhere else finds in *nesiotes* its maximum expression. If *nesiotes* stood alone, it is so distinct from *Sula leucogaster plotus*, the widespread race of the Pacific Ocean marked by very dark coloration, and from *Sula leucogaster leucogaster* of Atlantic areas, in which the head and neck are darker than the back and wings, that it would appear as a distinct species. The connecting links are found in *brexesteri* and *etsiaca*.

Recently van Rossem has described another form<sup>2</sup> from Isabel Island near the Tres Marias group as similar to *brexesteri* but with smaller and more slender bill, paler upper parts and chest, and the male with the head white. His conclusion is based in part on specimens in the National Museum. While I have not seen van Rossem's type, I have had available 9 males and 8 females from Isabel and the adjacent Tres Marias Islands. These birds are identical in coloration with skins from Clipperton, the type locality of *nesiotes*, so far as I

<sup>2</sup> *Sula leucogastra albiceps* van Rossem. Trans. San Diego Soc. Nat. Hist., vol. 9, No. 4, November 21, 1938, p. 9 (Isabel Island, western Mexico).

can see. While at first glance they appear smaller than *nesiotes*, with the considerable series I have seen this is not indicated in actual measurement. Following is a summary of the dimensions of the available specimens from Isabel Island and the Tres Marias:

Males (9 specimens), wing 366-389 (375), tail 161-193 (183), culmen from base 85.6-92 (89.4), depth of bill at gonydeal angle 11.1-12.2 (11.5), tarsus 43.5-48.5 (46.3), middle toe with claw 69-76.7 (72.7) mm.

Females (8 specimens), wing 391-418 (403), tail 178-198 (185), culmen from base 92.8-100 (95.3), depth of bill at gonydeal angle 11.9-14 (12.9), tarsus 45.0-53.5 (48.8), middle toe with claw 72.9-83.8 (78.6) mm.

Comparing these figures with those based on the birds from Clipperton we find that the wing lengths are almost identical. In length of culmen the smallest birds come from the supposed "*albiceps*" group, the average difference in length of culmen amounting to about 4 percent, but there is definite overlap in individuals. The bill also is very slightly more slender, though here again there is individual variation. The length of the tarsus in the two is quite similar, though the Isabel-Tres Marias specimens seem to have slightly smaller feet as indicated by the length of the middle toe with claw. On the basis of the material seen it appears to me that the differences presented are slight and do not permit recognition of *albiceps* as distinct from *nesiotes* at present, especially in view of the large size of the birds concerned, a conclusion reached only after somewhat prolonged consideration. Possibly more material may bring out the size distinction clearly, but from what I have seen I should expect instead that it might nearly or entirely disappear. It is only fair, however, to add that Mr. van Rossem has examined the National Museum material with me and does not agree.

*Sula leucogaster etesiaca* Thayer and Bangs:

*Sula etesiaca* THAYER and BANGS, Bull. Mus. Comp. Zoöl., vol. 46, June 1905, p. 92 (Gorgona Island, Colombia).

Similar to *brewsteri* but darker; male with light color of head as in *brewsteri* but apparently less extensive in the fully adult bird; female closely similar to *plotus* but slightly darker and more uniform in shade of brown.

*Range*.—Cocos Island, Costa Rica, through the Pearl Islands, Panama, to Gorgona Island, Colombia.

*Measurements* (in millimeters).—Males (15 specimens), wing 360-384 (370); tail 183-187 (181), culmen from base 82-93.3 (88.6).

depth of bill at gonydeal angle 10.5-12 (11.3), tarsus 44.8-48 (45.5), middle toe with claw 68.8-78 (73.5).

Females (14 specimens), wing 385-408 (397), tail 182-198 (189), culmen from base 89.6-103.2 (95.8), depth of bill at gonydeal angle 12.3-14.1 (13.3), tarsus 46.8-49.8 (48.2), middle toe with claw 75.8-82.7 (79.3).

As indicated above, in color this form most closely resembles *breasteri* though the range of the decidedly different *nesiotes* intervenes. Birds from Cocos Island are very slightly paler than those from the Pearl Islands and Gorgona but the difference is too slight to warrant their recognition as distinct. This form has been recorded from the Galapagos Islands but wrongly in my belief. There is one old skin in the National Museum marked "Galapagos Islands," but I consider the locality erroneous.

*Sula leucogaster leucogaster* (Boddaert) of tropical Atlantic areas, in which male and female are similar, is marked by having the head and neck darker than the back and wings. *Sula leucogaster plotus* of the central and western tropical Pacific Ocean, which also has the sexes alike, is darker, being the darkest of the races of this bird.

### Family LARIDAE

#### STERNA FUSCATA CRISSALIS (Lawrence)

##### SOCORRO SOOTY TERN

*Haliplana fuliginosa* var. *crissalis* LAWRENCE, Proc. Boston Soc. Nat. Hist., vol. 14, 1871 (1872), p. 285 (Socorro Island, Revillagigedo Islands).

The four specimens, two males and two females, are all adult birds. They are identified to subspecies according to the treatment of Ridgway.<sup>3</sup>

*Measurements* (in millimeters).—Males, wing 280-282, tail 169-170, culmen from base 43.5-47.5, tarsus 21-22.5.

Females, wing 274-275, tail 154-161, culmen from base 40.8-41.1, tarsus 21.3-23.3.

#### ANOÛS STOLIDUS RIDGWAYI Anthony

##### SOCORRO NODDY TERN

*Anous stolidus ridgwayi* ANTHONY, Auk, vol. 15, 1898, p. 36 (Socorro Island, Revillagigedo Islands).

Five males and five females of this interesting bird were obtained, together with two young that are just attaining the plumage of the first fall.

<sup>3</sup> U. S. Nat. Mus. Bull. 50, pt. 8, 1919, p. 519.

**ANOÛS MINUTUS DIAMESUS (Heller and Snodgrass)**

COCOS BLACK NODDY TERN

*Micranous diamesus* HELLER and SNODGRASS, Condor, vol. 3, 1901, p. 76  
(Cocos Island).

Two females and one young bird half grown were obtained. I agree with Peters that there is no reason for placing this species in a genus apart from the larger noddy.

**GYGIS ALBA CANDIDA (Gmelin)**

COCOS FAIRY TERN

*Sterna candida* GMELIN, Syst. Nat., vol. 1, pt. 2, 1789, p. 607 (Christmas Island, Pacific Ocean).

Two males and one female, all adult, of this beautiful bird were collected. The uniformity of the fairy tern in size over wide areas of the Pacific Ocean is surprising. I can find no pertinent difference between these skins from Clipperton Island and those from farther west, and so follow Ridgway in calling them *candida*, though I have seen no specimens from Christmas Island, the type locality. It seems probable that too many forms of the fairy tern have been recognized, but this can be settled only with more material than is available here at present.

While Hartert<sup>4</sup> has called the peculiar *Gygis microrhyncha* of the Marquesas Islands a geographic race of *alba*, in my opinion this is not correct. There are at present eight skins of *microrhyncha* in the National Museum, and I have seen additional material. All are uniform in differing from *alba* from many localities in the decidedly slender bill, a character in which specimens from other localities make no approach. Their relationship has been confused because of the uniform appearance of these terns throughout the world, and I consider *microrhyncha* a full species, distinct from the wide ranging *alba*.

---

<sup>4</sup> Nov. Zool., vol. 34, 1927, p. 20.



SMITHSONIAN MISCELLANEOUS COLLECTIONS  
VOLUME 98, NUMBER 23

STIMULATIVE EFFECT OF SHORT WAVE  
LENGTHS OF THE ULTRAVIOLET ON THE  
ALGA STICHOCOCCUS BACILLARIS

(WITH FOUR PLATES)



BY  
FLORENCE E. MEIER  
Division of Radiation and Organisms  
Smithsonian Institution



(PUBLICATION 3549)

CITY OF WASHINGTON  
PUBLISHED BY THE SMITHSONIAN INSTITUTION  
SEPTEMBER 26, 1939



SMITHSONIAN MISCELLANEOUS COLLECTIONS  
VOLUME 98, NUMBER 23

STIMULATIVE EFFECT OF SHORT WAVE  
LENGTHS OF THE ULTRAVIOLET ON THE  
ALGA STICHOCOCCUS BACILLARIS

(WITH FOUR PLATES)

BY  
FLORENCE E. MEIER  
Division of Radiation and Organisms  
Smithsonian Institution



(PUBLICATION 3549)

CITY OF WASHINGTON  
PUBLISHED BY THE SMITHSONIAN INSTITUTION  
SEPTEMBER 26, 1939

The Lord Baltimore Press  
BALTIMORE, MD., U. S. A.

STIMULATIVE EFFECT OF SHORT WAVE LENGTHS  
OF THE ULTRAVIOLET ON THE ALGA  
STICHOCOCCUS BACILLARIS

BY FLORENCE E. MEIER

*Division of Radiation and Organisms, Smithsonian Institution*

(WITH FOUR PLATES)

INTRODUCTION

During the course of previous quantitative research on the lethal effect of 21 wave lengths of the ultraviolet ranging from 2250 to 3130 A. on a green alga, the author (Meier, 1932, 1934, 1936) observed from time to time accelerated increase in cell mass with slightly less exposure than the lethal exposure that destroyed the plant cells. The purpose of the present study is to show quantitatively the stimulative action of definite short wave lengths of the ultraviolet on growth as measured by cell multiplication in a unicellular green alga, a stimulative action that has persisted over a period of 2 years in the same cultures without additional treatment.

By means of a quartz mercury-vapor arc and a fused-quartz prism spectrograph, exposures were made to the wave lengths 2652 and 2967 A. A spectrograph with crystal quartz prisms was used for the irradiations with the wave lengths 2352 and 2483 A. Absolute measurements of the intensity of the lines were made with a Clark vacuum thermocouple as described by Johnston and Weintraub (1939) and a double monochromator as in the method described by Brackett and McAlister (1932).

The spectroscopic manipulations and physical measurements were made by Dr. E. D. McAlister, of the Division of Radiation and Organisms.

I wish to express my appreciation to Dr. C. G. Abbot, Secretary of the Smithsonian Institution, for his counsel and assistance during the progress of this investigation. I am also grateful to Dr. E. S. Johnston and other members of the Division of Radiation and Organisms who have aided me in this research.

## LITERATURE REVIEW

Several investigators have studied the problem of stimulation of growth resulting from irradiation by short wave lengths of the ultraviolet which are generally considered lethal. The chief difficulty consists in the correct control of conditions for a quantitative determination of the stimulating exposure for an organism.

Gilles (1938), in his treatise of 286 pages on "Effets des Rayons Ultra-violetes sur les Végétaux Supérieurs," offers a very comprehensive survey of all the research that has been carried on up to 1938 on the destructive and favorable effects of the ultraviolet on both higher plants and microorganisms. This book, supplemented by the review made by Wynd and Reynolds (1935) of all the investigations that have been made on ultraviolet and respiratory phenomena, and by the review made by Sperti, Loofbourow, and Dwyer (1937) on the stimulative effect of ultraviolet on microorganisms, covers the literature thoroughly.

In this paper I shall mention briefly the principal investigations that have been made on the stimulative effect of short wave lengths of the ultraviolet on microorganisms.

Chavarría and Clark (1924) found that when certain pathogenic fungi very resistant to ultraviolet were given sublethal exposures of ultraviolet from a quartz mercury arc, they showed marked evidence of stimulation and grew larger than the controls. They observed that the stage of stimulation was brief and that lethal action followed rapidly in nonpigmented cells, but where pigment formed during irradiation, the cell was protected and its whole reaction was slowed down so that the stage of stimulation was relatively prominent and the lethal action was delayed. Fungi that are less resistant to the ultraviolet when treated with sublethal exposures produced feeble colonies, which in a few days grew to the size of the controls and when autoinoculation of the culture medium occurred, the daughter colonies were unusually vigorous.

Porter and Bockstahler (1928) report stimulated spore formation in the fungus *Colletotrichum* when exposed to radiations between 3630 and 3650 Å. produced by a Cooper-Hewitt mercury arc.

Stevens (1928), in his researches on perithecia formation in fungi, observed that a "very common, though not universal, effect of irradiation is to increase sexual or asexual production if such occurs normally and in some species to induce the sexual stage where it does not occur normally." The exposure was to full radiation from a Cooper-Hewitt mercury arc. Half of the colony on the agar plate was shaded

with cardboard to serve as a control. By means of various screens the activating region was found to lie probably between 2760 and 3130 Å.

Nadson and Philippov (1928) used a quartz mercury-vapor lamp to irradiate petri-dish cultures of pure cultures of yeasts and fungi covered with thick glass or metal with an opening in the center. The growth directly under the opening was completely destroyed by the ultraviolet. The part protected by the screen developed normally, but immediately surrounding the sterile zone was a bracelet of very intense growth where the culture partially protected by the screen had been touched by only the oblique rays. The yeasts in this region presented exaggerated budding; for example, the cell of the yeast *Nadsonia fulvescens*, which normally forms from one to three buds, in this case formed at its extremities whole groups or bouquets of buds. The mother cell, excited by the irradiation to such intense multiplication, swelled up, then, worn out, degenerated and perished. The group of young cells, dissociated by this fact, continued to live independently and to multiply by budding. In the zone of stimulation, *Mucor guilliermondii* asexually produced large quantities of sporangia, while on the other hand, sexual reproduction of *Mucor genevensis* was stimulated.

Ramsey and Bailey (1930) found a definite stimulation of spore production in cultures of *Macrosporium tomato* and *Fusarium cepae* on exposure to ultraviolet radiation from a quartz mercury arc. The greatest amount of spore production occurred when filters with the lower limits of transmission between 2535 and 2800 Å. were used. There was stimulation also with irradiations of 2535 Å. and shorter wave lengths, but with these exposures there was also some lethal effect and inhibition of mycelial development.

Hutchinson and Ashton (1930), using a quartz mercury-vapor lamp and a Hilger monochromatic illuminator, found that irradiation with the short wave length 2700 Å. caused early retardation of growth followed by stimulation in the fungus *Colletotrichum phomoides* and in yeast. Early sporulation of *Colletotrichum* resulted from irradiation with 3132, 3022, 2804, 2700, 2054, and 1854 Å.; early acervuli development occurred after irradiation with 2535 Å.

Smith (1935) reports stimulated spore production in *Fusarium curnartii* Carp., regardless of the growth rate of the fungus after irradiation with a Cooper-Hewitt mercury arc lamp.

De Fazi and de Fazi (1915) describe experiments showing that *Saccharomyces opuntiae*, when irradiated with ultraviolet, lived, reproduced, and fermented more actively.

Lindner (1922) also irradiated yeast with ultraviolet and found that it increased the speed of fermentation. He reports that 20 to 30 per cent of the cells in the irradiated culture died, thus indicating that he had given the cells a sublethal dose of ultraviolet.

Owen (1933) reports increased fermentative power of yeast caused by irradiation with a carbon arc, which is rich in wave lengths 2300 to 3100 Å.

Hollaender and Curtis (1935), on irradiating colonies of bacteria, *Escherichia coli*, with monochromatic ultraviolet radiation below 3000 Å. with exposures that killed some of the organisms but not all of them, found that growth of the surviving irradiated bacteria was retarded as compared with the control (nonirradiated) bacteria. But when the bacteria had completed their growth, the same number of organisms was present in both the irradiated and the control suspensions. The irradiated culture increased in number quite rapidly in the early part of the "lag phase," then slowed down, thus suggesting stimulation. Tests showed that the increased growth of the irradiated bacteria was not produced by the decomposition products of the dead bacteria or by the excretion of any substance by the irradiated organisms. The authors thought that stimulation was suggested, but the possibility of recovery of the irradiated bacteria should not be entirely excluded.

Hollaender and Duggar (1937), in their treatment of yeast and bacteria with sublethal doses of 2650 Å., observed that the survivors of the irradiation proliferated when transferred to salt solutions in which the controls died.

Loofbourow and others (1938, 1939), from their intensive studies on the stimulating effect of ultraviolet and other lethal agents in sublethal quantities on cells, believe that the effect is due to the production by injured living cells of "wound hormones," released as a physiologic response to injury into the intercellular medium. Their work is on embryo chicks and mouse tissues, yeast, and bacteria.

#### EXPERIMENTAL PROCEDURE

In the experiments on the lethal effect of the ultraviolet rays, the alga *Chlorella vulgaris* was found to be well adapted to the research because of the uniformity and speed with which the single oval cells covered the surface of the agar plates used. For experimentation involving direct counting, this alga is highly unsatisfactory owing to the minute and irregular size of the cells, which vary from 3 to 5  $\mu$ , and to the fact that the cell multiplies by oval or elliptical spores, which may range in number from two to four.



The unicellular green alga *Stichococcus bacillaris* Naegeli lends itself more satisfactorily to precise and accurate counting and measurement because of its size and method of multiplication. This alga has an elongated cell usually varying from 2 to 2.5  $\mu$  in width and 4 to 8  $\mu$  in length. Multiplication takes place by transverse division of the protoplast that partially fills the cell and by the formation of cross walls, thus developing two cells in place of the one parent cell. The nucleus usually lies near the center of the cell. (See pl. 3.) Filaments of more than two cells were rarely observed in my cultures. The alga develops rapidly, forming a green deposit in Detmer 1/3 solution.

The nutritive solution Detmer 1/3, which was used entirely for this series of experiments, was made up in the following proportions and then diluted 1/3:

Calcium nitrate .....	1.0	gram
Potassium chloride .....	0.25	"
Magnesium sulphate .....	0.25	"
Potassium acid phosphate.....	0.25	"
Ferric chloride .....	0.002	"
Distilled water .....	1.0	liter

Before irradiation, algae were pipetted from actively growing cultures into small quartz tubes, which were designed and constructed by L. B. Clark, of the Division of Radiation and Organisms. One side of each tube was flattened so as to insure equal and complete irradiation of the contents. Each quartz tube was equipped with a slender wire stirrer inserted through the cork so that the culture could be stirred during irradiation. (See fig. 1.) After the stemlike base of the tube had been securely inserted in a rubber stopper so placed as to hold the tube directly in the monochromatic ray of ultraviolet, the tube was examined with a piece of uranium glass to insure that the contents were covered by the ultraviolet ray. The quartz tube transmitted approximately 90 percent of the ultraviolet ray. A separate quartz tube was used for each exposure. Thermocouple measurements of the intensity were made before and after each experiment. The ultraviolet lamp was turned on half an hour before each experiment so that the intensity of the radiation was constant when the thermocouple measurements were made. The control cultures were treated exactly in the same manner as the irradiated cultures except that they were not exposed to the ultraviolet.

After irradiation, the contents of each tube were pipetted into a 300-cc. Erlenmeyer flask containing 200 cc. of Detmer 1/3, which had been sterilized in the autoclave at 20 pounds pressure for 15

minutes. After being thoroughly agitated, 100 cc. of the culture were poured into a second 300-cc. Erlenmeyer flask so that duplicate cultures were obtained for each exposure. The flasks were equipped with rubber stoppers, which were found to be more satisfactory than cotton plugs, previous experimentation having shown that the algae grew equally well in the rubber-stoppered flask and the flask with a cotton



FIG. 1.—Quartz tube with flattened side and stirrer. Natural size.

plug provided the cultures were inoculated a week or more after the flasks of culture medium had been autoclaved.

The cells of three drops of the culture from each flask were counted directly after irradiation, and the mean of the three cell counts was taken as the initial cell count. The same pipette used for making the drops for the initial count was marked, cleaned with ether, and put away for use with the same culture 2 weeks later when the final count

was made in similar fashion to the initial count. A separate pipette was assigned to each flask. In this manner equal drops were obtained from each culture. The quartz irradiation tube contained generally 24 drops of inoculum, which were divided between the two Erlenmeyer flasks in the manner described above. The number of cells per drop of inoculum for each culture of the same experiment was fairly uniform. The number of cells per drop of inoculum varied in the different experiments.

To insure counting every cell in a drop, a special microscope slide was etched for the purpose by L. A. Fillmen, of the Division of Radiation and Organisms, in the following manner: The slide was coated with a thin layer of beeswax and then ruled into rectangles on the milling machine with a sharp-pointed tool. The lines were 1 mm. apart lengthwise and 4 mm. apart crosswise. The lines were etched into the glass by placing a drop of hydrofluoric acid with a glass rod on the slide, and by spreading the drop with the glass rod into the grooves where it rested for a fraction of a minute. The acid was washed off with water, the beeswax was scraped off with a sharp flat tool, and the slide was cleaned.

The special pipettes made by L. B. Clark were drawn to a point so that a drop from each could be covered completely by a No. 2 A,  $\frac{3}{8}$ -inch cover glass. By using a euscope attachment to the microscope and a mechanical stage, it was a simple matter to count every cell on the slide with either the high-power or the low-power objective and a No. 5 ocular.

#### THE GROWTH CHAMBER

During the early experiments conducted in 1937 the algae in the Erlenmeyer flasks were grown during the 2 weeks following irradiation in natural conditions of day and night at variable room temperature in the north window on the eleventh floor of the Smithsonian flag tower. These environmental conditions of growth proved to be entirely too variable, as shown by the results for the experiments with algae grown under uncontrolled conditions presented in tables 1-4.

To arrange an ideal environment for the growth of the cultures after irradiation, an electric refrigerator was equipped with a thermostat, which regulated the temperature of the inner chamber at a constant temperature of 24° C. during the day and 22° C. at night. The new fluorescent daylight lamps were tested and proved to produce better growth conditions for the algae than varying daylight (see pl. 1). A set of four of these daylight lamps, each of which was 15 watts and

TABLE 1.—Growth of the alga *Stichococcus bacillaris* Vauché in relation to curve length 2352 A

Experiment No.	Uncontrolled growth conditions						Controlled growth conditions					
	1		2		3		1		2		3	
	Date	Intensity, ergs/sec.cm. <sup>2</sup>	Date	Intensity, ergs/sec.cm. <sup>2</sup>	Date	Intensity, ergs/sec.cm. <sup>2</sup>	Date	Intensity, ergs/sec.cm. <sup>2</sup>	Date	Intensity, ergs/sec.cm. <sup>2</sup>	Date	Intensity, ergs/sec.cm. <sup>2</sup>
Apr. 28, 1937	600	May 18, 1937	500	June 3, 1937	500	March 6, 1939	600	March 15, 1939	570	March 28, 1939	580	
Exposure	Growth rate	÷3	Growth rate	÷1.7	Growth rate	÷1.7	Growth rate	÷1.4	Growth rate	÷1.4	Growth rate	÷1.4
0 (control)	3.0 3.5	1 1	2.6 1.7	1 1	1.76 1.00	1 1	1.4 1.4	1 1	1.4 1.5	1 1	1.4 1.4	1 1 1
2	2.8 3.8	0.93 1.3										
4	3.4 3.6	1.1 1.2					1.9 2.2	1.4 1.6	1.3 1.5	0.92 1.0		
6	3.1 2.8	1.0 0.93										
8	3.6 4.7	1.2 1.6	1.1 1.2	0.64 0.71	2.02 2.60	1.2 1.5	2.4 2.2	1.7 1.6	1.1 1.1	0.79 0.79	1.6 1.3	1.1 0.93
12	5.1 4.1	1.7 1.4	4.5 4.8	2.6 2.8	4.48 4.54	2.6 2.7	2.5 3.2	1.8 2.3	1.4 1.1	1.0 0.79	2.2 2.0	1.6 1.4 1.5 1.4
16			3.5 2.0	2.1 1.2	1.05 1.86	0.62 1.1	1.1 1.1	0.79 0.79	2.0 1.3	1.4 0.93		
20			1.3 1.7	0.76 1.0	0.50 0.52	0.29 0.31	1.0 1.1	0.71 0.79	0.50 0.76	0.36 0.54		
24			1.6 1.5	0.94 0.88								
30					0.70 0.57	0.41 0.34						

TABLE 2.—*Growth of the alga Stichococcus bacillaris Naegeli in relation to wave length 2483 Å*

Experiment No.	Uncontrolled growth conditions		Controlled growth conditions					
	1		1		2		3	
Date.....	Nov. 15, 1937		April 11, 1939		April 19, 1939		April 27, 1939	
Intensity, ergs, sec.cm. <sup>2</sup> ..	2660		2620		2650		2640	
Exposure.....	Growth rate	÷1.5	Growth rate	÷1.4	Growth rate	÷1.6	Growth rate	÷1.3
<i>Seconds</i>								
0 (control).....	1.5	1	1.4	1	1.5	1	1.3	1
10.....			1.4	1	1.7	1	1.2	1
							1.5	1.2
15.....	5.0	3.3					1.5	1.2
	1.9	1.3						
20.....							1.9	1.6
							1.9	1.6
30.....	3.5	2.3	7.9	5.6	2.3	1.4		
	2.6	1.7	8.5	6.0	2.4	1.5		
40.....							1.3	1
							1.3	1
60.....	2.3	1.5	1.9	1.4	1.5	1		
	3.3	2.2	2.0	1.4	1.6	1		
80.....							1.2	1
							1.4	1
90.....	2.4	1.6						
	2.7	1.8						
100.....			1.0	0.71	1.2	0.75		
			1.0	0.71	1.2	0.75		
120.....	1.1	0.7						
	0.65	0.4						
180.....			1.2	0.86	1.1	0.69		
			1.5	1.1	1.2	0.75		

TABLE 3.—*Growth of the alga Stichococcus bacillaris Naegeli in relation to wave length 2652 Å*

Experiment No.	Uncontrolled growth conditions				Controlled growth conditions					
	1		2		1		2		3	
Date . . . . .	March 1, 1937		March 31, 1937		Dec. 8, 1938		Dec. 21, 1938		Jan. 11, 1939	
Intensity, ergs/sec.cm. <sup>2</sup> . . . . .	2100		2100		1950		1080		1950	
Exposure . . . . .	Growth rate	÷0.89	Growth rate	÷1.6	Growth rate	÷1.7	Growth rate	÷1.7	Growth rate	÷1.6
<i>Seconds</i>										
0 (control) . . . . .	0.86	1	2.6	1	1.8	1	1.7	1	1.5	1
	0.91	1	1.5	1	1.6	1	1.6	1	1.6	1
									1.4	1
									1.7	1
10 . . . . .	1.4	1.6	2.2	1.3	1.9	1.1	2.7	1.7		
	2.1	2.3	1.5	0.96	1.7	1.0	2.8	1.8		
20 . . . . .	2.0	2.3	4.6	2.9	1.9	1.1	2.5	1.6	1.5	0.93
	1.6	1.8	4.5	2.8	1.8	1.1	2.6	1.6	2.0	1.3
									1.8	1.1
									1.9	1.2
30 . . . . .	3.2	3.5	4.6	2.9	1.5	0.82	2.6	1.6		
	2.3	2.6			1.2	0.71	2.6	1.6		
40 . . . . .	4.2	4.7	6.8	4.3	3.9	2.2	1.7	1.1	3.0	1.9
	4.2	4.7	7.1	4.4	3.3	1.9	2.9	1.9	2.0	1.3
									2.6	1.6
									2.4	1.5
60 . . . . .	0.88	0.99	1.0	0.63	0.71	0.41	1.1	0.69		
	0.87	0.98	1.0	0.63	0.79	0.46	0.92	0.58		

TABLE 4.—*Growth of the alga Stichococcus bacillaris Naegeli in relation to wave length 2967 Å*

Experiment No.	Uncontrolled growth conditions				Controlled growth conditions					
	1		2		1		2		3	
Date.....	July 19, 1937		Sept. 24, 1937		Feb. 1, 1939		Feb. 6, 1939		Feb. 27, 1939	
Intensity, ergs/sec.cm. <sup>2</sup> ...	2500		2380		2400		2350		2370	
Exposure.....	Growth rate	÷0	Growth rate	÷2.5	Growth rate	÷1.4	Growth rate	÷2.2	Growth rate	÷1.4
Seconds 0 (control)	7.5	1	2.3	1	1.4	1	2.1	1	1.4	1
	10.6	1	2.6	1	1.4	1	2.2	1	1.6	1
									1.3	1
									1.4	1
33.....	6.3	0.69	1.8	0.72						
	5.0	0.56	1.6	0.62						
67.....	5.7	0.63	1.5	0.75	1.4	1	1.8	0.80		
	11.0	1.2	1.9	0.60	1.4	1	1.9	0.86		
100.....	9.4	1.0	3.5	1.4	1.2	0.87	1.5	0.69		
	7.2	0.80	3.2	1.3	1.3	0.95	1.3	0.59		
133.....	9.5	1.1	7.2	2.9	1.2	0.85	1.8	0.81	1.9	1.4
	12.8	1.4	7.3	2.9	1.4	1.0	1.7	0.77	1.6	1.1
									1.9	1.4
									1.8	1.3
200.....	2.2	0.24	4.5	1.8	2.1	1.5	2.9	1.3	2.6	1.9
	2.2	0.24	5.0	2.0	2.4	1.7	2.4	1.1	2.7	1.9
									2.7	1.9
									2.6	1.9
260.....					0.51	0.36	1.1	0.50		
					0.83	0.59	1.4	0.64		

18 inches in length, was installed. The lights gave an intensity of approximately 150 foot-candles on the bottom shelf and 300 foot-candles on the top shelf.

The flasks of algae were placed on the lower shelf of this chamber and illuminated for 12 hours of each 24 hours (see pl. 2) during their growth period of two weeks.

## RESULTS

All the results have been tabulated in tables 1-10 for convenient reference.

### THE STIMULATED GROWTH RATE

The results of the cell counts are tabulated in tables 1-4 and 6-9. In each case, the growth rate represents the final count made 2 weeks after irradiation divided by the initial count made directly after irradiation. Each growth rate of an irradiated culture was then divided by the growth rate of the control to obtain the final growth ratio.

In plotting the curves (see fig. 2), all the points for the final growth ratios were considered. This includes the points found in the set of experiments run with old stimulated cultures as described later. The figures near the points in the curves represent the number of observations entering into the mean. In plotting the curve for 2483 Å., certain observations that seemed very wild were rejected in the preferred diagram, drawn with full lines. The dotted curves represent all the observations.

As shown by studying the curves and the tables, the highest point of stimulation for all the wave lengths is at approximately two-thirds of the intensity of the lethal threshold. The greatest amount of stimulation was found by exposure to the wave length 2652 Å., and the smallest amount to the wave length 2967 Å. These results correspond to the radiotoxic spectral sensitivity of green algae found previously (Meier, 1936). Some stimulation was obtained by shorter exposures than the optimum to each of these four wave lengths.

To check the lethal threshold points found in the liquid cultures, the following experiment was conducted. Green algal cells growing in Detmer 1/3 were pipetted into the quartz tubes. After irradiation, the cells were pipetted into petri dishes containing sterilized Detmer 1/3 agar. They were then placed in the growth chamber and observations were made daily. The results as given below show that the lethal points correspond to those obtained in the liquid cultures.

2352 Å.		2483 Å.		2652 Å.		2967 Å.	
500 ergs/sec.cm. <sup>2</sup>		2,600 ergs/sec.cm. <sup>2</sup>		1,950 ergs/sec.cm. <sup>2</sup>		2,350 ergs/sec.cm. <sup>2</sup>	
Control	Green	Control	Green	Control	Green	Control	Green
20 min.	Lethal	1 min.	"	1 min.	Lethal	4 min.	Lethal
20 "	"	1 "	"	1 "	"	4 "	"
40 "	"	2 "	Lethal	2 "	"	6 "	"
40 "	"	2 "	"	2 "	"	6 "	"
70 "	"	3 "	"	3 "	"	9 "	"
70 "	"	3 "	"	3 "	"	9 "	"
120 "	"	5 "	"	5 "	"	12 "	"
120 "	"	5 "	"	5 "	"	12 "	"



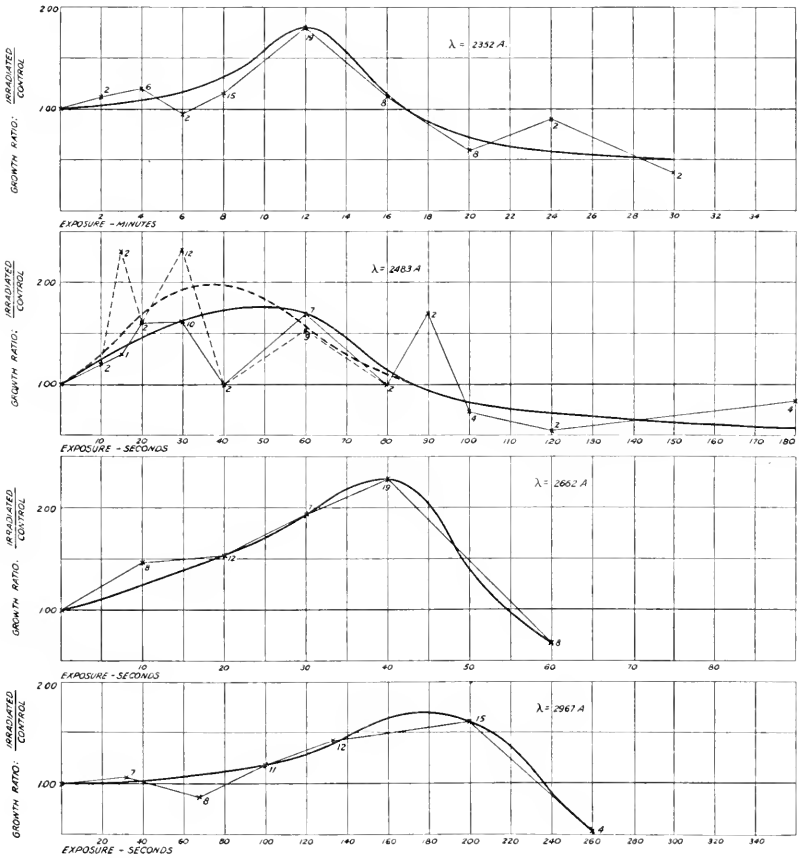

FIG. 2.—Stimulative action on cell multiplication of the alga *Stichococcus bacillaris* Naegeli resulting from exposures to ultraviolet rays. Dark line, smooth curve; light line, actual values. The figures indicate the number of observations.

## STIMULATED GROWTH FROM OLD STIMULATED CULTURES

In 1939 it was observed that the old cultures that had been growing undisturbed since their growth count 2 weeks after irradiation in 1937 presented a sufficient growth of algae for weighing. Several cultures were filtered, and when the dry weights were obtained the weights of the stimulated cultures proved to be much greater than those of the controls (see table 5). The 2652 A. cultures were filtered through previously weighed filter paper, and then the precipitate and the filter paper were dried in the electric oven before weighing. The 2967 A. cultures were filtered through filter papers that had been previously dried and each weighed with its small covered aluminum pan. The filter papers of algae were then placed each in its pan in the

TABLE 5.—*Dry Weight of Algae 2 Years after Inoculation*

Wave length	Date	Exposure	Tare	Tare + Algae	Algae	$\frac{S}{C}$
A. 2652	1937 Mar. 30	0 sec. (control) . . . . .	gm. .624	gm. .647	gm. .023	1
		40 sec. . . . .	.570	.621	.051	2.2
2967	July 19	0 sec. (control) (A) .	17.993	17.998	.005	1
		200 sec. (A) . . . . .	18.187	18.208	.021	4.2
		0 sec. (control) (B) .	17.674	17.681	.007	1
		200 sec. (B) . . . . .	17.663	17.681	.018	2.6

oven and dried for a much longer period than the 2652 A. cultures. These data are of value in that they indicate continued increase in multiplication of the cells for a period of 2 years.

To check this finding, a series of experiments was performed with cultures that had been irradiated and allowed to stand undisturbed over a period of time. Flasks of fresh culture solution were inoculated with inoculum from the stimulated cultures and from the control culture of each series. Cell counts were made as described above directly after inoculation, and 2 weeks after the new series of cultures had been placed in the growth chamber. In each case, as shown in tables 6-9, the growth rate was higher in the stimulated cultures than in the control, proving that the accelerated rate of multiplication of the algal cells, increased by irradiation with the ultraviolet, had persisted for a period of 2 years.

TABLE 6.—*Persistent Stimulated Growth Obtained from Cultures Formerly Stimulated by Wave Length 2352 Å*

Experiment No....	1		2		3	
Date inoculum was irradiated....	June 3, 1937		May 18, 1937		May 18, 1937	
Date of experiment	March 8, 1939		April 4, 1939		April 14, 1939	
Exposure.....	Growth rate	÷1.6	Growth rate	÷1.3	Growth rate	÷1.5
<i>Minutes</i>						
0 (control) ...	1.7	1	1.1	1	1.4	1
	1.8	1	1.3	1	1.3	1
	1.4	1	1.5	1	1.3	1
12.....	2.5	1.6	2.5	1.9	2.8	2.2
	2.9	1.8	2.7	2.0	3.4	2.6
	2.9	1.8	3.0	2.3	2.9	2.2

TABLE 7.—*Persistent Stimulated Growth Obtained from Cultures Formerly Stimulated by Wave Length 2483 Å*

Experiment No....	1		2		3	
Date inoculum was irradiated....	Dec. 7, 1937		Dec. 7, 1937		Dec. 7, 1937	
Date of experiment	May 3, 1939		May 8, 1939		May 9, 1939	
Exposure.....	Growth rate	÷1.3	Growth rate	÷1.4	Growth rate	÷1.1
<i>Seconds</i>						
0 (control) ...	1.2	1	1.2	1	1.1	1
	1.2	1	1.4	1	1.1	1
	1.4	1	1.5	1	1.2	1
30.....	2.0	1.5	.....	.....	1.6	1.5
	2.6	2.0	.....	.....	1.6	1.5
	2.0	1.5	.....	.....	1.4	1.3
60.....	.....	.....	2.4	1.7	.....	.....
	.....	.....	2.2	1.6	.....	.....
	.....	.....	2.8	2.0	.....	.....

TABLE 8.—*Persistent Stimulated Growth Obtained from Cultures Formerly Stimulated by Wave Length 2652 Å*

Experiment No....	1		2		3	
Date inoculum was irradiated . . .	Dec. 8, 1938		Jan. 11, 1939		Dec. 8, 1938	
Date of experiment	March 10, 1939		April 6, 1939		April 14, 1939	
Exposure . . . . .	Growth rate	÷1.4	Growth rate	÷2.1	Growth rate	÷1.6
<i>Seconds</i>						
0 (control) . . .	1.4	1	2.2	1	1.4	1
	1.5	1	2.2	1	1.8	1
			2.0	1	1.7	1
			2.0	1		
40 . . . . .	3.2	2.3	2.8	1.3	2.1	1.3
	3.2	2.3	2.7	1.3	2.7	1.7
			3.3	1.6	2.2	1.4
			2.6	1.3		

TABLE 9.—*Persistent Stimulated Growth Obtained from Cultures Formerly Stimulated by Wave Length 2967 Å*

Experiment No....	1		2		3	
Date inoculum was irradiated . . .	July 19, 1937		July 19, 1937		July 19, 1937	
Date of experiment	May 10, 1939		May 15, 1939		May 23, 1939	
Exposure . . . . .	Growth rate	÷1.3	Growth rate	÷1.2	Growth rate	÷1.1
<i>Seconds</i>						
0 (control) . . .	1.4	1	1.2	1	1.1	1
	1.3	1	1.2	1	1.0	1
	1.2	1	1.2	1	1.1	1
33 . . . . .			1.9	1.6		
			1.9	1.6		
			1.8	1.5		
100 . . . . .	2.3	1.8				
	2.2	1.7				
	2.4	1.9				
200 . . . . .					1.9	1.7
					3.1	2.8
					2.2	2.0

## APPEARANCE OF THE CELLS

The lengths and the widths of 20 cells in each culture were measured with an ocular micrometer. From these data the means of the measurements of 100 cells from the most highly stimulated cultures and of 100 cells from the corresponding controls were computed and the results tabulated in table 10. The measurements of the stimulated cultures under 2352 Å. are from the cultures exposed to that wave length for 12 minutes, the set under 2483 Å. from those with 30 seconds' exposure, the set under 2652 Å. from those with 30 and 40 seconds' exposure, and the set of measurements under 2967 Å. from those with 133 and 200 seconds' exposure. The ratios were computed by dividing the mean length of the measurements for 100 cells of the stimulated cultures by the mean length for 100 cells of the controls. The ratios for the width were obtained in a similar manner.

TABLE 10.—Cell Measurements<sup>1</sup>

Å	Mean length, $\mu$		Ratio $\frac{S}{C}$	Mean width, $\mu$		Ratio $\frac{S}{C}$
	Stimulated	Control	%	Stimulated	Control	%
2352	5.512	5.88	93.7	1.107	1.092	101.4
2483	5.272	5.392	97.7	1.196	1.20	99.7
2652	4.99	5.11	97.6	1.168	1.096	106.6
2967	5.24	5.745	91.2	1.128	1.067	105.7
			95.0			103.3

<sup>1</sup> The mean is of 100 cells in each case from representative cultures.

A study of the tables shows that the cells in the stimulated cultures are shorter and wider than those in the control cultures. This is to be expected as the rate of the multiplication of the stimulated cultures is so much higher than that of the control cultures that the stimulated cells probably do not have time to attain the length found under normal conditions before they divide to form new cells.

Plates 3 and 4 show photomicrographs of cells from stimulated cultures and their corresponding controls made 2 years after inoculation and irradiation. The cells of the stimulated cultures are darker than those of the controls due to the greener appearance of the chlorophyll. They are also shorter and wider than the cells of the controls. More dead discolored cells are present in the control cultures than in the stimulated cultures.

## CONCLUSIONS

A stimulative action causing increased cell multiplication of the green alga *Stichococcus bacillaris* Naeg. has been found to result

from sublethal exposures of the short wave lengths of the ultraviolet 2352, 2483, 2652, and 2967 Å. The optimum stimulation point occurs at approximately two-thirds of the lethal exposure. The stimulative action is not transitory but has persisted in the cultures over a period of 2 years. At the end of 2 years' time, the cells in the stimulated cultures are in better condition than those in the controls. The algal cells from the stimulated cultures are slightly shorter and wider than those in the controls.

## LITERATURE CITED

- BRACKETT, F. S., AND McALISTER, E. D.  
 1932. A spectrophotometric development for biological and photochemical investigations. *Smithsonian Misc. Coll.*, vol. 87, No. 12, pp. 1-7.
- CILAVARRIA, ANTONIO PENA, AND CLARK, JANET H.  
 1924. The reaction of pathogenic fungi to ultra-violet light and the role played by pigment in this reaction. *Amer. Journ. Hygiene*, vol. 5, pp. 639-649.
- DE FAZI, ROMOLO, AND DE FAZI, REMO.  
 1915. Azione dei raggi ultravioletti sulla fermentazione alcoolica. *Ann. Chim. Appl.*, vol. 4, pp. 301-329.
- FARDON, JOHN C., NORRIS, ROBERT J., LOOFBOUROW, JOHN R., AND RUDDY, SISTER M. VERONITA.  
 1937. Stimulating materials obtained from injured and killed cells. *Nature*, vol. 139, p. 589.
- GILLES, EDMOND.  
 1938. Effets des rayons ultra-violets sur les végétaux supérieurs. 286 pp. Lyon.
- HOLLAENDER, ALEXANDER, AND CLAUS, WALTER D.  
 1936. Bactericidal effect of ultraviolet on *Escherichia coli* in liquid suspensions. *Journ. Gen. Physiol.*, vol. 19, pp. 753-765.  
 1937. An experimental study of the problem of mitogenetic radiation. *Nat. Res. Comm. Bull.* 100, pp. 1-96.
- HOLLAENDER, ALEXANDER, AND CURTIS, JOHN T.  
 1935. Effect of sublethal doses of monochromatic ultraviolet radiation on bacteria in liquid suspensions. *Proc. Soc. Exper. Biol.*, vol. 33, No. 1, pp. 61-62.
- HOLLAENDER, ALEXANDER, AND DUGGAR, B. M.  
 1937. Some effects of ultraviolet radiation on bacteria. *Journ. Bact.*, vol. 33, No. 1, p. 16.
- HUTCHINSON, A. H., AND ASHTON, M. R.  
 1930. The effect of radiant energy on growth and sporulation in *Colletotrichum phomoides*. *Can. Journ. Res.*, vol. 3, No. 3, pp. 187-199.
- JOHNSTON, EARL S., AND WEINTRAUB, ROBERT L.  
 1939. The determination of small amounts of chlorophyll—Apparatus and method. *Smithsonian Misc. Coll.*, vol. 98, No. 19, pp. 1-5.
- LINDNER, P.  
 1922. Zur Wirkung ultravioletter Strahlen auf die alkoholische Gärung und auf Hefe. *Wochenschr. Brauerei*, vol. 39, No. 29, pp. 166-167.

- LOOFBOUROW, JOHN R., COOK, ELTON S., AND STIMSON, SISTER MIRIAM MICHAEL.  
1938. Chemical nature of proliferation-promoting factors from injured cells. *Nature*, vol. 142, p. 573.
- LOOFBOUROW, JOHN R., CUETO, ANDRE A., AND LANE, SISTER MARY MICHAELLA.  
1939. Stimulation of tissue culture growth by intercellular wound hormones from injured tissues. *Arch. Exper. Zellf. Gewebz. (Explantation)*, vol. 22, pp. 607-613.
- LOOFBOUROW, JOHN R., DWYER, SISTER CECELIA MARIE, AND MORGAN, SISTER MARY NORBERT.  
1938. Intercellular wound hormones from ultraviolet injured cells. *Stud. Inst. Divi Thomae*, vol. 1, pp. 137-153.
- MEIER, FLORENCE E.  
1932. Lethal action of ultra-violet light on a unicellular green alga. *Smithsonian Misc. Coll.*, vol. 87, No. 10, pp. 1-11.  
1934. Lethal response of the alga *Chlorella vulgaris* to ultraviolet rays. *Smithsonian Misc. Coll.*, vol. 92, No. 3, pp. 1-12.  
1936. Lethal effect of short wave lengths of the ultraviolet on the alga *Chlorella vulgaris*. *Smithsonian Misc. Coll.*, vol. 95, No. 2, pp. 1-19.
- NADSON, G., AND PHILIPPOV, G.  
1928. Action excitante des rayons ultraviolets sur le developpement des levures et des moisissures. *Compt. Rend. Mem. Soc. Biol.*, vol. 198, No. 5, pp. 366-368.
- OWEN, WILLIAM L.  
1933. Ultra-violet irradiation stimulates yeast activity. *Food Industries*, vol. 5, No. 7, pp. 252-254.
- PORTER, C. L., AND BOCKSTAHLER, H. W.  
1928. Concerning the reaction of certain fungi to various wave lengths of light. *Proc. Indiana Acad. Sci.*, vol. 38, pp. 133-135.
- RAMSEY, G. B., AND BAILEY, ALICE ALLEN.  
1930. Effects of ultra-violet radiation upon sporulation in *Macrosporium* and *Fusarium*. *Bot. Gaz.*, vol. 89, No. 2, pp. 113-130.
- SMITH, ELIZABETH C.  
1935. Effects of ultra-violet radiation and temperature on *Fusarium*. II. Stimulation. *Bull. Torrey Bot. Club*, vol. 62, No. 3, pp. 151-164.
- SPErtl, GEORGE SPErtI, LOOFBOUROW, JOHN R., AND DWYER, SISTER CECELIA MARIE.  
1937. Proliferation-promoting substances from cells injured by ultra-violet radiation. *Nature*, vol. 140, p. 643.
- STEVENS, F. L.  
1928. The sexual stage of fungi induced by ultra-violet rays. *Science*, n.s., vol. 67, No. 1742, pp. 514-515.  
1931. Further observations regarding ultra-violet irradiation and perithecial development. *Philippine Agriculturist*, vol. 10, No. 8, pp. 491-499.
- WYND, F. LYLE, AND REYNOLDS, E. S.  
1935. Studies in ultra-violet and respiratory phenomena. *Ann. Missouri Bot. Gard.*, vol. 22, No. 4, pp. 771-835.





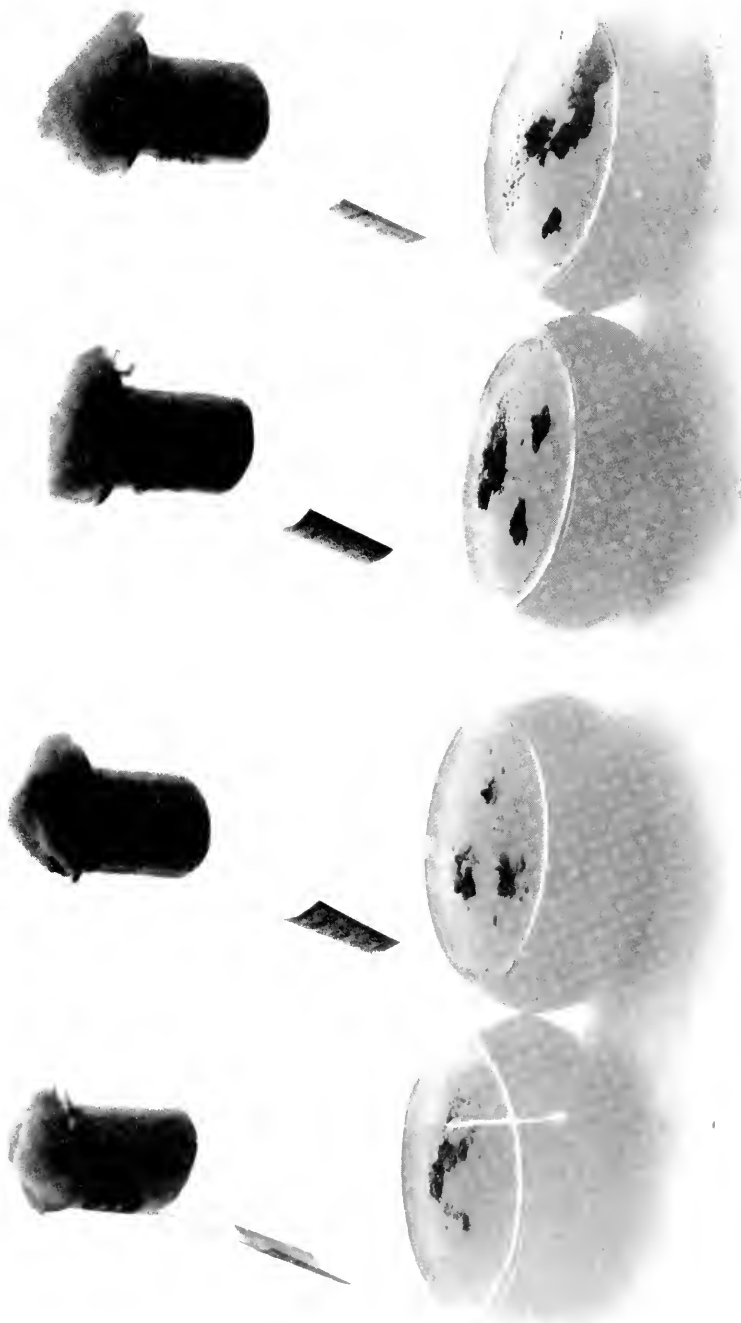

TWO CULTURES AT LEFT ARE OF ALGAE GROWN IN NATURAL CONDITIONS OF DAY AND NIGHT; TWO CULTURES AT RIGHT ARE OF ALGAE GROWN FOR THE SAME PERIOD OF TIME IN THE GROWTH CHAMBER UNDER SUNLIGHT LAMPS 12 HOURS A DAY

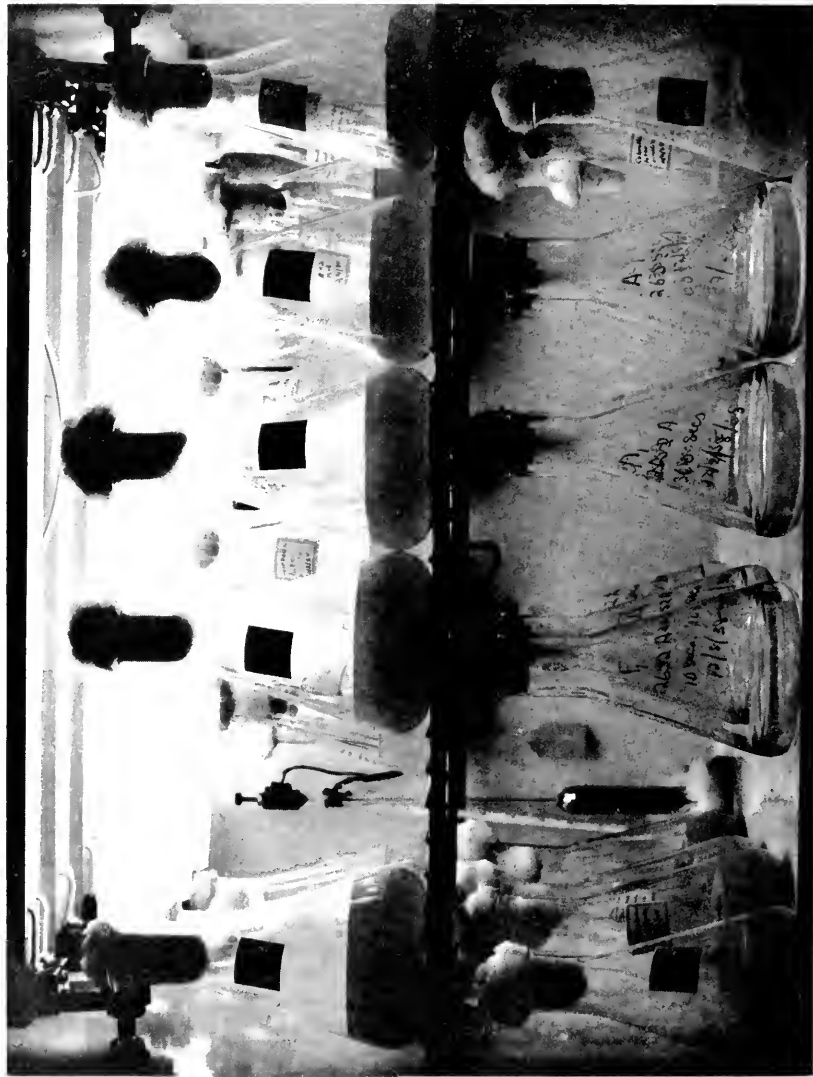

INTERIOR OF THE GROWTH CHAMBER

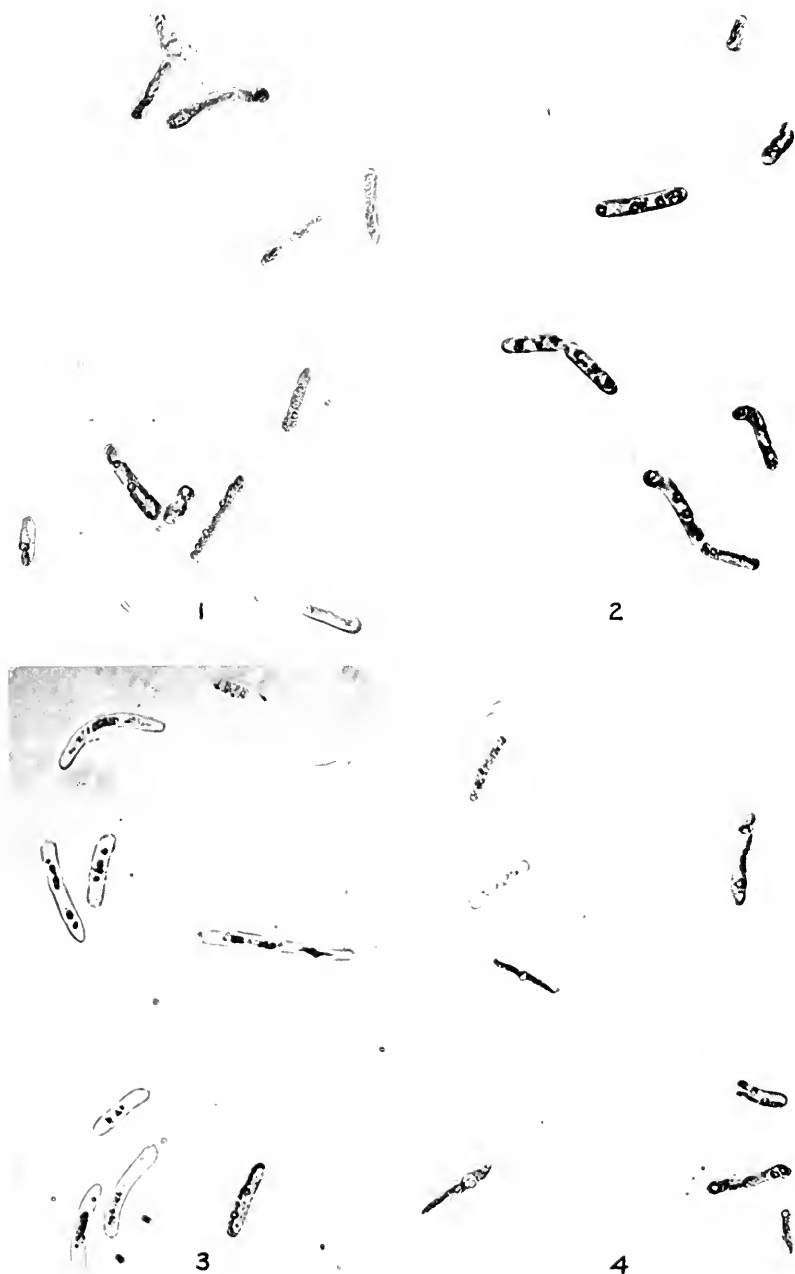

1, ALGAE IN CONTROL CULTURE; 2, ALGAE IRRADIATED 12 MINUTES WITH 2352 A.; 3, ALGAE IN CONTROL CULTURE; 4, ALGAE IRRADIATED 100 SECONDS WITH 2967 A. ALL FOUR PHOTOMICROGRAPHS WERE TAKEN 2 YEARS AFTER IRRADIATION. X 250



UPPER: CONTROL: LOWER: ALGAE IRRADIATED 12 MINUTES WITH 2352 Å.  
BOTH PHOTOMICROGRAPHS WERE TAKEN 2 YEARS  
AFTER IRRADIATION X 100

SMITHSONIAN MISCELLANEOUS COLLECTIONS  
VOLUME 98, NUMBER 24

THE PTARMIGANIA STRATA OF THE  
NORTHERN WASATCH  
MOUNTAINS

(WITH 14 PLATES)

BY

CHARLES ELMER RESSER

Curator, Division of Stratigraphic Paleontology  
U. S. National Museum

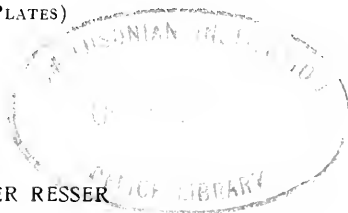

(PUBLICATION 3550)

CITY OF WASHINGTON  
PUBLISHED BY THE SMITHSONIAN INSTITUTION  
OCTOBER 26, 1939



SMITHSONIAN MISCELLANEOUS COLLECTIONS  
VOLUME 98, NUMBER 24

THE PTARMIGANIA STRATA OF THE  
NORTHERN WASATCH  
MOUNTAINS

(WITH 14 PLATES)

BY  
CHARLES ELMER RESSER  
Curator, Division of Stratigraphic Paleontology  
U. S. National Museum



(PUBLICATION 3550)

CITY OF WASHINGTON  
PUBLISHED BY THE SMITHSONIAN INSTITUTION  
OCTOBER 26, 1939

The Lord Baltimore Press  
BALTIMORE, MD., U. S. A.



# THE PTARMIGANIA STRATA OF THE NORTHERN WASATCH MOUNTAINS

BY CHARLES ELMER RESSER

*Curator, Division of Stratigraphic Palaeontology  
U. S. National Museum*

(WITH 14 PLATES)

## INTRODUCTION

An interesting fauna occurs in the lowermost Middle Cambrian beds at several places in the northern Wasatch Mountains of Idaho and Utah. The fauna is characterized by great variety of species and genera, and the numerous individuals are excellently preserved, chiefly in crystalline limestone. Most of the material here described was collected by Walcott in 1898 and 1906. When I came to Washington in 1914 as Dr. Walcott's assistant, the first task assigned to me was the preparation of this material.

Two classes of data are necessary for the advancement of stratigraphy: First, there must be a sufficient number of sections, measured at strategic points, to furnish knowledge of areal extent and of variations in lithology and in thickness of the sheets of sediment that constitute the formations; second, it is necessary to know the faunas characterizing the formations. This paper describes another fauna but also discusses some stratigraphic problems. Unfortunately the stratigraphic terminology of the Wasatch Mountains is not fully satisfactory; hence a hybrid faunal-stratigraphic title is used.

Recently the related fauna in the superjacent Spence shale was described (Resser, 1939). Taken together these faunas should enable the building of the early Middle Cambrian portion of the column with greater precision, not only locally but throughout the Cordilleran region.

Sections of Middle Cambrian rocks were measured in the northern Wasatch Mountains by Walcott in 1898 and 1906 and subsequently by other geologists. The only detailed mapping in the region is that

of the Randolph quadrangle, which includes the eastern slopes of the Bear River Range. That report is in press. Without detailed mapping of a considerable area, it is not possible to understand fully the stratigraphic relations, for the early Middle Cambrian sequence may be incomplete, and some of the formations seem to vary in thickness and lithology more than usual for Cambrian strata in the central Cordilleran region.

In 1906 Walcott measured the Cambrian strata at four widely separated points but published the results as a single composite section (1908a, b). This obscured variations in lithology and thickness and made correlation uncertain. If, however, we go back to the original field notes, thereby getting away from the confusion introduced with the composite section, several facts became clear. Deiss (1938) remeasured the Blacksmith Fork section and discussed the stratigraphy and stratigraphic terminology in the light of the information yielded by that one section.

With a better understanding of the Spence shale and immediately subjacent *Ptarmigania* faunas and by using information from related sections, as well as the results of mapping of the Randolph quadrangle, it is now possible to advance a step or two toward a solution of the Middle Cambrian stratigraphy of the northern Wasatch region.

At first it was planned to publish only the fossil descriptions, but as the work progressed it became increasingly desirable to determine stratigraphic relationships so that the faunal affinities could be better understood. Seemingly there is yet much to learn concerning the composition and position of Middle Cambrian faunas, for they appear to be less clear-cut than those in the Upper Cambrian formations. This situation no doubt has contributed to the slow development of Middle Cambrian stratigraphy and to the uncertainty of present correlations. At present it seems that nearly all the common Middle Cambrian genera range throughout most of the division. And further, it seems that one or another genus may undergo great expansion at any time evidently without following a particular evolutionary trend. Moreover, it is apparent that conspicuous elements of several faunas may be present or absent from place to place. In short, at the present stage of knowledge, Middle Cambrian faunas are not clear-cut entities, and their composition varies more than should be expected. This state of affairs can scarcely be attributed to inadequate collection alone, although there is no doubt that further field work will fill in many gaps.

## LOCATION AND TOPOGRAPHY

The location and general topographic expression of the Wasatch Mountains are well known. The conspicuous rampart of these mountains east of Great Salt Lake and the ranges in northeastern Utah and southeastern Idaho are familiar. In this paper we are concerned only with the northern portion of these mountains from the vicinity of Brigham to their termini in Idaho.

The high, abrupt slope of the Wasatch Mountains facing Great Salt Lake Valley continues from Salt Lake City northward to Malad, which is about 15 miles north of the Idaho State line. Several gaps interrupt the range, the most conspicuous being formed by the Bear River as it breaks through from Cache Valley. North of Malad the less elevated Bannock Range continues the trend of the Wasatch Mountains but is composed of younger strata.

Between Ogden and Brigham many ridges occupy an area more than 25 miles wide. In the eastern portion of this area the ridges are grouped together as the Bear River Range, which extends thence north through Utah and into Idaho as far as Soda Springs, some 40 miles north of the Idaho boundary.

Cache Valley lies between the two prongs, the Wasatch proper on the west and the Bear River Range on the east. Cache Valley has a nearly level floor about 4,500 feet above sea level. East of it the Bear River Range rises abruptly to altitudes of about 9,000 feet, and on the west the Wasatch also rises steeply to about the same height. Thus there is a V-shaped mountain mass that surrounds Cache Valley, and is in turn bounded on the west by Salt Lake Valley and on the east by Bear Lake and Valley.

## GENERAL GEOLOGY

As shown by the geological map of Utah, crystalline pre-Cambrian rocks occupy the front of the Wasatch Mountains between Salt Lake City and Ogden. Eastward these rocks are succeeded immediately by Tertiary beds. From Ogden to Brigham the Willard overthrust puts Cambrian rocks on the face of the range in contact with a belt of pre-Cambrian rocks. This belt of crystalline rocks is overlain on the east by Cambrian and younger Paleozoic strata in normal sequence. Since the strike here is northwesterly at an angle to the mountain front the Cambrian rocks again come to the front of the range north of Brigham for a distance of several miles, their place then being taken by younger Paleozoic beds. North of the Bear River Gap

Cambrian strata again constitute the front, and most of the species described in this paper are from Two Mile Canyon, which crosses this outcrop belt.

In the Bear River Range Middle and Upper Cambrian strata crop out over considerable areas, but their full extent is not known. The best-known section is in Blacksmith Fork Canyon, and another excellent section lies north of Garden City on the eastern slope. Mill Creek west of Liberty, nearly 25 miles north of the Idaho boundary, also exposes a fine Cambrian section. Here the quartzite yields a fauna, and the recently described Spence shale fauna overlies the discontinuous limestone with the *Ptarmigania* fauna.

The generalized geological map of northeastern Utah, therefore, shows Cache Valley as a northward-pitching syncline, since it is surrounded by belts of successively older strata from the Carboniferous to the Cambrian. More detailed mapping does not bear out this structure, but the map does show where Cambrian rocks are found.

#### MATERIAL AVAILABLE

*Stratigraphic data.*—Measured sections extending through the Middle Cambrian sequence are available at four localities, and partial sections at two other places in the northern Wasatch Mountains.

In 1898 and 1906 Walcott measured the section in Two Mile Canyon, which is near the northern end of the Wasatch proper. In the same season he examined the outcrops in Box Elder Canyon, the Mantua Basin, and north of Brigham but recorded measurements for only a portion of the sequence.

During 1906 Walcott, assisted by L. D. Burling, followed up his earlier studies of 1898 in the Bear River Range and measured the sections in Blacksmith Fork east of the southern end of Cache Valley and along Mill Creek west of Liberty, on the eastern slope of the range. In 1909 Blackwelder measured the section on Mill Creek, a tributary entering Blacksmith Fork from the south. This is a few miles south of the place where Walcott worked, but both geologists agree closely in the subdivisions adopted, the lithologic descriptions, and the thicknesses recorded. Recently (1938) Deiss remeasured and republished the Blacksmith Fork section. Walcott recorded 4,190 feet of Middle Cambrian beds above the quartzite, Blackwelder 4,125, and Deiss 3,885, which is remarkably close agreement. These observers also recognize the same formational subdivisions with nearly the same respective thicknesses and lithology.

In 1912 G. B. Richardson (1913) of the United States Geological Survey, assisted by P. V. Roundy, began the mapping of the Randolph quadrangle, which lies east of Blacksmith Fork. He discovered an isolated Cambrian outcrop in Laketown Canyon, where only a portion of the sequence is exposed. He also found that the Middle Cambrian is exposed on the eastern slopes of the Bear River Range throughout the quadrangle with particularly good sections just north of Garden City, in the upper St. Charles Canyon, and on Mill Creek. The full report of the work in the Randolph quadrangle is now in press.

Between 1923 and 1930 I saw all the mentioned sections except Mill Creek west of Liberty. This locality was not located during those seasons because nearly every geographic name in the vicinity had been changed when the topographic sheet was published in 1911. Recently it has been possible to interpret these changes from old notes and labels, and the Spence shale locality has been relocated by Bishop Paul A. Spence, of Garden City, the son of the original discoverer. In the following discussion use is made of the original notes of Walcott, Blackwelder, and myself rather than of Walcott's published composite section. Much of the information derived from the mapping of the Randolph also is available.

*Paleontologic material.*—As listed below, fossils are described from all the mentioned sections. All of Richardson's collections are also in hand. While descriptions are confined to the *Ptarmigania* fauna and species supposedly belonging to it, the other fossils from the base of the Middle Cambrian to the top of the Ute formation were examined in order that the position of the *Ptarmigania* fauna could be understood. The fossils from the overlying strata are to be published shortly, many species having now been described in manuscript.

Further details respecting number of species, quantity of specimens, and the matrix in which they are preserved will be found subsequently in the description of the sections.

#### CAMBRIAN DEVELOPMENT

The general distribution of the Cambrian in the northern Wasatch region has been described. A few facts regarding its development are now in order. In the following paragraphs the absence of Lower Cambrian beds and the formational subdivisions of the Middle Cambrian are briefly discussed. Descriptions of the formations are not repeated because the definitions given by Walcott and Deiss suffice. However, considerable detail will be found in the discussion of the sections, where unpublished notes are also presented.

## ABSENCE OF LOWER CAMBRIAN

Lower Cambrian strata are apparently absent in the Wasatch Mountains northward of Salt Lake City. At the southern end of the range near Mount Nebo, in Cottonwood Canyon, south of Salt Lake City, and on Promontory Point in Great Salt Lake, about 20 miles west of the Wasatch Mountains, fossils show that the Lower Cambrian seas extended northeastward from southern California and Nevada at least as far as the mentioned points. Wherever the base of the Cambrian beds is exposed north of Salt Lake City, the Brigham quartzite is seen to rest directly on pre-Cambrian rocks. The situation obtains also in the Salt River and Teton Ranges of western Wyoming, in the northwestern part of Yellowstone Park, and throughout Montana. In my opinion the Lower Cambrian rocks found in the vicinity of Great Salt Lake possibly continue beneath younger strata and the lava fields, to connect with outcrops in northeastern Washington and beyond that with beds of similar age in the Columbia Valley and Dogtooth Mountains of British Columbia. Since Lower Cambrian strata are clearly absent in the northern Wasatch region, and thence northward through western Wyoming and Montana, the question arises whether the lowest Cambrian beds exposed are the oldest Middle Cambrian, or whether some Middle Cambrian also is lacking.

## MIDDLE CAMBRIAN FORMATIONS

The three independent measurements combined with the fact of excellent exposure of a complete sequence results in Blacksmith Fork becoming the basic section of the area. All other sections that have been investigated agree closely, with the exception to be subsequently noted. Six formations evidently constitute the Middle Cambrian sequence for the northern Wasatch region. A condensed table is presented for ready reference.

In the Blacksmith Fork section the figures in parenthesis are Deiss' measurements; those in brackets are Blackwelder's. The Randolph quadrangle section is composite but is based primarily on the exposures immediately northeast of Garden City. The figures for Two Mile Canyon may not be wholly reliable, since accurate adjustment may not have been made for all the faults that interrupt the section. While the sequence exposed near the crest of the range north of Brigham is evidently the same as at Two Mile Canyon, Walcott's notes are insufficient to warrant inclusion of a column in the table.

The Brigham quartzite is seldom fully exposed. For this reason it is omitted in the following comparisons. From the figures in the foregoing table it is apparent that the thinnest Middle Cambrian section is recorded on Mill Creek, west of Liberty. The next in order is that of Two Mile Canyon and the thickest section is found near Garden City. Thus it seems that the total thickness increases from

Two Mile Canyon	Mill Creek, Liberty	Blacksmith Fork	Randolph quadrangle
Nounan 1,090 feet	Nounan 815 feet	Nounan 1,040 feet (900 feet) [1,010 feet]	Nounan 950 feet
Bloomington 555 feet	Bloomington 1,160 feet	Bloomington 1,320 feet (1,275 feet) [1,190 feet]	Bloomington 1,250 feet [Includes Hodges shale member at base 325-350 feet]
Blacksmith 585 feet	Blacksmith 360 feet	Blacksmith 570 feet (450 feet) [560 feet]	Blacksmith 700 feet
Ute 800 feet Spence shale 155 feet	Ute 400 feet Spence shale 40 feet	Ute 730 feet (685 feet) [695 feet] Spence shale 30 feet	Ute 480-585 feet [Spence shale included]
"Langston" 6 feet	"Langston" 30 feet	Langston 500 feet (575 feet) [670 feet]	Langston 375 feet
Brigham 740 feet	Brigham 500-1,000 feet	Brigham 1,230 feet+ (1,000 feet) [200+ feet]	Brigham 1,600+ feet

northwest to southeast. Moreover, if the aberrant thickness for the Bloomington formation in Two Mile Canyon is overlooked, remarkably little variation appears among the upper three formations. Following description of the localities and sections the Langston question is discussed, which will focus attention on the variability of the lower three Middle Cambrian formations.

#### LOCALITIES

A concise list of localities is desirable to save frequent repetitions, particularly in the fossil and plate descriptions. Consequently the localities from which fossils are described are listed in numerical order. Subsequently the localities will appear again as the sections

are described, but then in a geographic arrangement. List of species will also be given with the sections.

*Locality 5b = 54s.*

*Locality 19:* T. 12 S., R. 42 E., ridge north of North Fork of Mill Creek, Preston quadrangle, Idaho. (Coll. G. R. Mansfield, July 17, 18, 1912.)

*Locality 19x:* North wall of Laketown Canyon, about 2½ miles southwest of Laketown, Randolph quadrangle, Utah. (Coll. P. V. Roundy, September 12, 1912.)

*Locality 20x:* Near top of gulch, about 2 miles north of Brigham, Wasatch Mountains, Utah. (Coll. C. E. Resser, A. A. L. Matthews, E. R. Pohl, September 12, 1926.)

*Locality 32p = 55c.*

*Locality 54s:* North side Two Mile Canyon, near its mouth, 2 miles southeast of Malad, Wasatch Mountains, Idaho. (Coll. F. B. Meek; C. D. Walcott, 1898; C. D. Walcott and L. D. Burling, 1906.)

*Locality 55c:* North of first small canyon south of Wasatch Canyon, 3½ miles north of Brigham, Wasatch Mountains, Utah. (Coll. F. B. Meek; C. D. Walcott and L. D. Burling, 1906.)

*Locality 55p:* About 7 miles above mouth of Blacksmith Fork, Bear River Range, Utah. (Coll. C. D. Walcott and L. D. Burling, August 27, 1906.)

*Locality 55q:* Same as preceding.

*Locality 59c:* Mill Canyon, about 5 miles southwest of Liberty and 15 miles west of Montpelier, Bear River Range, Idaho. (Coll. C. D. Walcott, September 1907.)

*Locality 59c:* Same as preceding.

*Locality 59f:* Same as preceding.

*Localities 322 and 322a:* These numbers were assigned to small lots of fossils from the eastern side of the Bear River Range, secured prior to 1906.

## STRATIGRAPHY

Publication of Walcott's original field notes seems warranted even though they are nearly 35 years old. Comments on the rock entombing the fossils, and such miscellaneous data as seem pertinent are also recorded in geographic arrangement. The fossil lists are placed in the descriptions of the sections where they occur. Where a section is not given lists appear with the miscellaneous notes. Where more than the *Ptarmigania* fauna is represented in a collection, the list is confined to the species regarded as representative of that fauna.

In nearly every case only slight modifications of Walcott's assignment of beds to formations are necessary. It was his intention to publish stratigraphic papers embodying these notes, but the necessary paleontologic studies could not be completed in his lifetime. In anticipation of publication he added comments to transcriptions of the field notes, particularly with respect to formational names and



boundaries. Additional comments have been added wherever deemed desirable, hence the material is not to be regarded as quoted. However no departure from figures, determination of beds, or lithologic description was allowed.

#### WASATCH MOUNTAINS

*Two Mile Canyon.*—Collections were made by Walcott in 1898 and 1906, and others by Meek at an earlier date. A section was measured October 1898 and remeasured in 1906 with particular attention to the upper beds. Faults required the measurements to be made in different blocks, but care was evidently exercised in carrying the section across the fault lines. The measured beds total 4,655 feet, including some post-Cambrian strata.

Walcott's section of the Middle Cambrian beds follows, the formational assignments being made in essentially the present manner by Walcott himself.<sup>1</sup>

#### *Nouan formation:*

Dolomite. Massive-bedded gray, passing upward into thin-bedded bluish-gray dolomite.....	Feet 405
Dolomite. Dirty gray, massive-bedded dolomite, banded in places.....	445
Limestone. Thin-bedded, bluish-gray impure limestone, with trilobites. The trilobites represent undescribed genera.....	58
Dolomite. Dirty gray, massive-bedded dolomite with a few shaly and sandy beds.....	180
Total .....	1,088

This and the overlying post-Cambrian beds were measured on the south side of the canyon.

#### *Bloomington formation:*

Limestone and shale. Alternating beds of thin-bedded limestone and sandy and argillaceous shale. Fossils are fairly common but are still undescribed.....	Feet 555
Total .....	555

<sup>1</sup>A few days before this paper was submitted for publication a letter from Prof. Deiss stated that he had examined the Two Mile Canyon section, May 1939. He furnished a copy of the lower part of his section, apparently as it was measured in a fault block. According to the figures given, 650 feet of Brigham quartzite remain above a thrust fault. Overlying the quartzite is 60 feet of impure limestone containing beds of pure crystalline limestone with the *Ptarmigania* fauna. A slight break separates the impure limestone stratum from 205 feet of Spence shale and possibly beds of the Ute formation.

*Blacksmith dolomite:*

	Feet
Dolomite. Light-gray dolomite in massive layers, alternating with bluish-gray layers. The latter contain many small dark "concretions" .....	445
Dolomite. Drab and lead-colored dolomite.....	140
Total .....	585

*Ute formation:*

Limestone. Bluish-gray limestone in thin and thick layers. About 180 feet above the base, fossils are abundant.....	350
Shale. Drab and green arenaceous shale.....	45
Dolomite. Thick-bedded, gray limestone alternating with thin beds....	57
Limestone and shale. Alternating beds of limestone and shale. Fossils..	113
Shale. Greenish, sandy shale.....	12
Dolomite and limestone. Thick-bedded bluish-gray dolomite with bands of thinner-bedded limestone.....	105
Shale and sandstone. Reddish-brown, sandy shale with a few layers of hard sandstone and a little green sandy shale near the top..	30
Limestone. Thin-bedded (3 to 8 inches), compact, hard limestone, with considerable dolomitic or arenaceous matter in some of the layers. Small fragments of fossils.....	85
Total .....	797

*Spence shale member:*

Limestone and shale. Blue-black calcareous shale and thin-bedded dark gray limestone. Sponge spicules are common (loc. 5g) ..	125
Dark argillaceous shale.....	30
Total .....	155

Measurements were made in the hills north of the canyon where faulting seems to be less serious. However, both the Ute and the beds assigned to the Spence shale member are much thicker than in the other sections, consequently it is possible that some faulting was overlooked. The typical Spence shale fauna, characterized by *Oryctcephalus* is present.

*"Langston" limestone:*

Limestone. Dark gray, crystalline, very fossiliferous limestone (loc. 54s) .....	6
Total .....	6

The fossils look like black velvet when first freed from the matrix. Thousands of specimens were secured, and many more could be uncovered in the larger pieces because fossils make up a large part

of the rock. As shown by the illustrations of *Taxioura typicalis*, the fossils often are so crowded that it is difficult to free good specimens.

<i>Acrothle artemis</i> Walcott	<i>Kootenia maladensis</i> , n. sp.
<i>Acrothle parilis</i> , n. sp.	<i>Kootenia nitida</i> , n. sp.
<i>Acrothya minor</i> Walcott	<i>Lingulella cucharis</i> , n. sp.
<i>Acrotreta cucharis</i> , n. sp.	<i>Micromitra haydeni</i> Walcott
<i>Acrotreta sulcata</i> Walcott	<i>Olenoides maladensis</i> , n. sp.
<i>Agnostus lautus</i> , n. sp.	<i>Oryctocephalites typicalis</i> , n. sp.
<i>Alokistocare cuchare</i> , n. sp.	<i>Oryctocephalus maladensis</i> , n. sp.
<i>Alokistocarella occidentis</i> , n. sp.	<i>Pachyaspis typicalis</i> , n. sp.
<i>Bathyriscus politus</i> , n. sp.	<i>Pagetia clytia</i> Walcott
<i>Dolichometopsis alia</i> , n. sp.	<i>Pagetia maladensis</i> , n. sp.
<i>Dolichometopsis comis</i> , n. sp.	<i>Paterina hirta</i> , n. sp.
<i>Dolichometopsis communis</i> , n. sp.	<i>Poulsenia granosa</i> , n. sp.
<i>Dolichometopsis gravis</i> , n. sp.	<i>Poulsenia occidentis</i> , n. sp.
<i>Dolichometopsis lepida</i> , n. sp.	<i>Prozacanthoides acquis</i> , n. sp.
<i>Dolichometopsis media</i> , n. sp.	<i>Prozacanthoides alatus</i> , n. sp.
<i>Dolichometopsis potens</i> , n. sp.	<i>Prozacanthoides decorosus</i> , n. sp.
<i>Dolichometopsis poulseni</i> , n. sp.	<i>Prozacanthoides exilis</i> , n. sp.
<i>Dolichometopsis propinqua</i> , n. sp.	<i>Prozacanthoides optatus</i> , n. sp.
<i>Dolichometopsis stella</i> , n. sp.	<i>Ptarmigania agrestis</i> , n. sp.
<i>Ehmaniella maladensis</i> , n. sp.	<i>Ptarmigania altilis</i> , n. sp.
<i>Helcionella aequa</i> , n. sp.	<i>Ptarmigania aurita</i> , n. sp.
<i>Helcionella arguta</i> , n. sp.	<i>Ptarmigania dignata</i> , n. sp.
<i>Hyalithes prolixus</i> , n. sp.	<i>Ptarmigania exigua</i> , n. sp.
<i>Iphidella maladensis</i> Walcott	<i>Ptarmigania germana</i> , n. sp.
<i>Kochaspis maladensis</i> , n. sp.	<i>Ptarmigania natalis</i> , n. sp.
<i>Kochina venusta</i> , n. sp.	<i>Ptarmigania ornata</i> , n. sp.
<i>Kochina vestita</i> , n. sp.	<i>Ptarmigania sobrina</i> , n. sp.
<i>Kochina wasatchensis</i> , n. sp.	<i>Ptarmigania</i> sp. undet.
<i>Kootenia acicularis</i> , n. sp.	<i>Taxioura magna</i> , n. sp.
<i>Kootenia brevispina</i> , n. sp.	<i>Taxioura typicalis</i> , n. sp.
<i>Kootenia convoluta</i> , n. sp.	<i>Tonkiuella idahoensis</i> , n. sp.
<i>Kootenia granulosa</i> , n. sp.	<i>Wimanella maladensis</i> , n. sp.

*Brigham quartzite:*

Shale. Greenish, arenaceous shale, with layers of quartzite and dark brown sandstone.....	Feet 45
Quartzite. Reddish-brown, quartzitic sandstone, like underlying bed...	205
Quartzite. Compact, hard, light-gray quartzitic sandstone. Bands of greenish, sandy shale interbedded in the upper 80 feet. Shaly surfaces covered with trails.....	210
Shale. Steel gray to buff, arenaceous shales, with layers of quartzite at intervals of 5 to 20 feet.....	115
Quartzitic sandstone. Massive-bedded (layers 2 to 8 feet thick) brown quartzitic sandstone.....	165
Base unexposed.	
Total .....	740

*Vicinity of Brigham City.*—The collections of the 40th Parallel Survey evidently were made from the shaly beds several miles north of Brigham City. In 1906 Walcott worked over the region and collected freely and in 1926 I secured large collections here. Cambrian beds crop out not only on the western ridge of the Wasatch, but in Box Elder Canyon, east of Brigham and particularly on the rims of the Mantua Basin at the head of the canyon. Walcott recorded the sequence but gave the thickness of only one bed.

<i>Blacksmith dolomite:</i>	Feet
Massive, gray dolomite.....	
<i>Ute and other formations:</i>	
Limestone or dolomite. Bluish-gray, massive-bedded limestone.....	
Limestone and shale. Gray, calcareous and siliceous shale, with thin-bedded bluish-black limestone (loc. 55e).....	193
Limestone. Bluish gray. This bed cannot be more than a few feet thick, according to information on the field labels.....	

The collections from localities 55e and 20x contain species from all the beds between the Brigham and Blacksmith formations. Below are listed only the species supposedly belonging to the *Ptarmigania* fauna. The selection was based on generic association and is not regarded as positive enough for correlation purposes. Locality 55e is about 150 feet above the quartzite and may yield only Spence shale species, but two species have been selected as older: *Lingulella eucharis* Resser and *Kochina brighamensis* n. sp. From locality 20x a larger number of species are referred to the *Ptarmigania* fauna, all of which are new.

<i>Alokestocarella brighamensis</i> , n. sp.	<i>Kootenia mendosa</i> , n. sp.
<i>Clavaspidella wasatchensis</i> , n. sp.	<i>Poliella wasatchensis</i> , n. sp.
<i>Girvanella</i> sp.	<i>Taxioura typicalis</i> , n. sp.
<i>Kochina? elongata</i> , n. sp.	<i>Wimanella maladensis</i> , n. sp.
<i>Kootenia germana</i> , n. sp.	

*Brigham quartzite:*

Gray quartzitic sandstone, weathering brown, with partings of green arenaceous shale.....	Feet
Base unexposed.	

BEAR RIVER RANGE

*Blacksmith Fork.*—It is not necessary to reprint the section in Blacksmith Fork Canyon. Notes relative to two lots of fossils from the Langston limestone is all that is needed.

Locality 55p, Langston formation. This material was collected by Walcott and Burling in 1906, between 70 and 100 feet below the top

of the formation. The species are *Glossopleura prona*, *G. arrecta*, and *Alokistocare globatum*.

Locality 55q. This collection was secured near the top of the Langston formation. The species are: *Glossopleura prona*, *G. arrecta*, *Kootenia pectenoides* and *Prozacanthoides* sp., and *Clavaspidella* sp.

It is possible, as Deiss contends, that these fossils do not represent the *Ptarmigania* fauna, but since they occur directly beneath the shale which contains Spence forms, they are described. It will be observed that these species do not require exclusion of the Langston fauna from the *Ptarmigania* zone. This question is discussed more fully subsequently.

*Mill Creek, west of Liberty.*—Mill Creek was known as Liberty Creek in 1906. Walcott's references to Spence Gulch mentions "Danish Flat," which now is Copenhagen Basin. Spence Gulch is not shown on the Preston or Montpelier quadrangle maps, but evidently is the stream coming into Mill Creek from the west, possibly in sections 10, 2, 3, T. 13 S., R. 42 E., of the Preston quadrangle.

The Middle Cambrian portion of Walcott's section on Mill Creek is as follows:

*Nouan formation:*

Dolomite. Massive-bedded, passing into bluish-gray, rough, weathering dolomite .....	Feet 450
Quartzite. Gray quartzitic rock.....	92
Dolomite and limestone. Dirty-gray calcareous beds, with fossils.....	272
Total .....	814

*Bloomington formation:*

Limestone. Bluish-gray limestone, in alternating massive and thin beds .....	385
Shale and limestone. Greenish argillaceous shale and thin- bedded limestone, with oboloid brachiopods.....	575
Limestone. Thin- and thick-bedded, bluish-gray limestone, with fossils at top and near the middle.....	202
Total .....	1,162

*Blacksmith dolomite:*

Gray dolomite .....	23
Thin-bedded, bluish-gray dolomite.....	335
Total .....	358

*Ute formation:*

	Feet
Shale. Greenish argillaceous shale.....	61
Limestone. Thin-bedded gray limestone.....	38
Shale. Micaceous, arenaceous shale.....	75
Limestone. Thin-bedded gray limestone.....	102
Shale. Argillaceous shale.....	35
Limestone. Thin-bedded limestone with fossils.....	85
Total .....	396

*Spence shale member:*

Shale. Dark, bluish-black and greenish argillaceous shale. The band of shale rests on the quartzitic sandstone and is nearly 40 feet thick.....	40
Total .....	40

This was designated the "*Zacanthoides* shale" in the field. The recently described Spence shale fauna, locality 55c, came from this locality.

*Langston formation:*

Limestone. "To the north 3 miles a bed of limestone 30 feet thick occurs between the quartzitic sandstones and the shale and at Blacksmith Fork Canyon there is 390 feet of siliceous limestone and 107 feet of bluish-gray limestone between the shale and the quartzitic sandstone. These conditions indicate that the Middle Cambrian was deposited upon an uneven surface."

Fossils were secured near the top (loc. 59f) and near the base (loc. 59e).....	30
Total .....	30

The field label with the collection from locality 59f reads "top of limestone below Spence shale." There is a slight variation in the rock of the collection. For instance, a somewhat impure crystalline limestone with yellowish specks contains only *Helcionella burlingi*, which species is lacking in typical crystalline limestone.

*Acrotreta eucharis*, n. sp.

*Kochina? libertyensis*, n. sp.

*Alokistocare euzona*, n. sp.

*Kootenia convoluta*, n. sp.

*Dolichometopsis* sp.

*Lingulella eucharis* Resser

*Inglefieldia idahoensis*, n. sp.

*Prozacanthoides libertyensis*, n. sp.

*Kochaspis idahoensis*, n. sp.

The field label with the collection from locality 59e reads, "base of limestone just above the quartzite and underlying the Spence shale." This lot contains a typical *Ptarmigania* fauna.

*Dolichometopsis gregalis*, n. sp.

*Dolichometopsis poulsenii*, n. sp.

*Dolichometopsis* sp.

*Kochaspis dispar*, n. sp.

Locality 198 evidently represents the same faunal zone, and was collected nearby.

*Acrotreta sulcata* Walcott  
*Dolichometopsis mansfieldi*, n. sp.  
*Kochiella mansfieldi*, n. sp.  
*Lingulella* sp.  
*Poulsenia bearensis*, n. sp.

Prior to 1906 several small lots of fossils were received from these beds. They were given the numbers 322 and 322a, and contain *Acrotreta sulcata* Walcott and *A. eucharis*, n. sp.

*Brigham quartzite:*

Thickness of exposure is not given. Fossils were found 75 feet below the top (loc. 59c). The collection contains fossils in quartzitic sandstone and in crystalline limestone. The field label reads, "75 feet below the top of the quartzite and 125 feet below the Spence shale." This shows a discrepancy of nearly 20 feet with the measurements given above.

In quartzitic sandstone :

*Hyalithes* sp.  
*Kochiella arenosa*, n. sp.  
*Ptychoparella* sp.

In limestone (most of the specimens are too fragmentary to identify specifically) :

<i>Alokistocare</i> sp.	<i>Kootenia libertyensis</i> , n. sp.
<i>Clavaspidella excavata</i> , n. sp.	<i>Kootenia venusta</i> , n. sp.
<i>Ehmaniella maladensis</i> , n. sp.	<i>Micromitra haydeni</i> Walcott
<i>Eocrinus?</i> sp.	<i>Nisusia</i> sp.
<i>Glossopleura</i> (2 species)	<i>Zacanthoides</i> sp.
<i>Iphidella</i> sp.	

*Randolph quadrangle.*—The Mill Creek section is in both the Preston and Randolph quadrangles. It is not necessary to reprint Richardson's section, which is based chiefly on the outcrops near Garden City (1913). In fact he does not give a detailed section, for he says: "The Cambrian section in the Randolph quadrangle is essentially that described by Walcott as occurring in Blacksmith Fork, Utah, and in the vicinity of Liberty, Idaho, and need not be described here." He then goes on to say that the Cambrian is well exposed west of Garden City where he measured the section.

Richardson differentiated the Hodges shale member at the base of the Bloomington. It is described as a persistent zone of drab clay shale 325 to 350 feet thick.

One species, *Kootenia bearensis*, is described from the isolated outcrop of the Langston formation in Laketown Canyon (loc. 19x).

#### THE LANGSTON FORMATION

The *Ptarmigania* fauna was regarded as fully representative of the Langston formation until Deiss (1938) questioned the validity of Walcott's determination of the Spence shale in Blacksmith Fork and the correlation of the thin fossiliferous limestone in the Two Mile Canyon and Liberty sections, immediately under the Spence shale, with the Langston at its type locality. If it were not for the great difference in thickness no question concerning the identity of the *Ptarmigania* beds with the Langston formation would have been raised. As the matter now stands two alternative interpretations are possible. First, we may assume as Walcott did, that the Langston formation is discontinuous but that it appears in the known sections, at some places attaining a thickness of 670 feet. The second alternative assumes that the Langston is absent in the northern part of the region and that the thin fossiliferous limestones occupying its stratigraphic position are lenses or bioherms in the base of the Ute, closely associated in origin with the Spence shale, or in the top of the Brigham. Determination of which is the more satisfactory interpretation requires careful field work, with tracing of the formation at least far enough to find out whether thickening of the fossiliferous limestone takes place southward. Pending field examination, and in preparation for it, we can examine the faunal evidence bearing on the problem.

All observers agree that the basal quartzite is the same formation throughout the region. However, if the Langston is absent in the northern part of the area, then the quartzite there may be somewhat younger, at least in part. All observers also agree that the Ute formation extends over the entire region, and everywhere has the same lithologic expression, and is characterized by the same faunas. Therefore, as previously stated, the question is whether the 6 to 30 feet of fossiliferous limestone in Two Mile Canyon and on Mill Creek near Liberty are thin equivalents of the Langston formation, which is from 500 to 650 feet thick in Blacksmith Fork and 375 feet near Garden City. Locally it does not make any difference how this question is determined but its proper understanding does have wide significance for precise correlation beyond the immediate region.

Lithology is without significance because the crystalline limestones containing the *Ptarmigania* fauna are of types common in typical



Langston. Nothing is recorded concerning the sedimentation of the beds, consequently unconformities, if present, have been overlooked. But with the lithologic and stratigraphic evidence in hand, it is possible to say that the *Ptarmigania* beds can be Langston equivalents. So if the *Ptarmigania* beds are not the Langston formation it must be proven solely by faunal evidence.

The composition and age of the *Ptarmigania* fauna are discussed later. Comparing that fauna with two collections in unquestioned Langston limestone, we see that they are not identical but closely related. Certainly they are not mutually exclusive. Without doubt the *Ptarmigania* fauna is very closely allied to that in the top of the Brigham formation on Mill Creek. Also it is closely allied with the Spence shale fauna. In other words it is not possible on faunal grounds to postulate a large gap in the Liberty section between the quartzite and the Spence shale.

The nearest relationships of the *Ptarmigania* to described faunas is to the *Albertella* fauna. If *Albertella* and *Vanuxemella* are removed from the typical *Albertella* fauna, the remaining genera are nearly all the same. *Kootenia* expands greatly and the Lower Cambrian elements such as *Poulsenia* and *Prozacanthoides* remain, so that the *Ptarmigania* fauna appears to belong in the early Middle Cambrian, possibly exactly equivalent to the Comet shale of Nevada.

To sum up, we can only say that the evidence in hand supports both interpretations, namely, that the *Ptarmigania* beds represent the Langston formation, or that the Langston is absent and these beds are bioherms in the basal Ute or top of the Brigham formation.<sup>2</sup>

#### COMPOSITION OF THE PTARMIGANIA FAUNA

Most of the species described in this paper come from the 6-foot limestone bed in Two Mile Canyon (loc. 54s), and they constitute the *Ptarmigania* fauna. It then remains to determine which other lots of fossils are exactly the same. Of the fossils herein described only those from the 30-foot limestone in the Mill Creek section (locs. 59e, 59f, 19s) are regarded as precise equivalents.

An effort has been made to determine faunules within the *Ptarmigania* fauna. Two are recognizable, but there is not much difference between them. All species are not indiscriminately mixed in any one piece of rock, but when association of species in many

---

<sup>2</sup>In his recent letter Prof. Deiss reports finding *Albertella* in Two Mile Canyon in May 1939. This substantiates the above argument.

pieces is tabulated the distinctions are found to have a tendency to disappear.

Most of the species now recognized from locality 54s are trilobites, and they are represented by hundreds of specimens. Besides abundance of individuals we also find that many genera are characterized by prolific species.

The brachiopods are represented by 9 species, falling within the common Middle Cambrian genera, *Micromitra*, *Paterina*, *Iphidella*, *Lingulella*, *Acrothela*, *Acrotreta*, and *Wimaneella*. *Acrothyra minor* is the only uncommon form. Gastropods are represented by *Helcionella* and *Hyalithes*.

The agnostids are represented by one species, which is closely allied to other Cordilleran species common in the Middle Cambrian.

The smaller trilobites are represented by two species of *Pagetia* and a pygidium referred to *Tonkinella*. *Oryctocephalus* is sparingly represented, but the new related genus *Oryctocephalites* is more abundant. On the whole the small forms constitute a minor element of the fauna, however abundant the individuals may be. Next in size are the species of *Prozacanthoides*, which genus underwent a great expansion. The form that first attracts attention is the large new trilobite *Taxioura*, which is represented by two species.

The most characteristic forms are the 9 species of *Ptarmigania* and the 11 species of the closely related *Dolichometopsis*. There is only one pygidium of *Bathyriscus*. The wide-brimmed forms, *Alo-kistocarella*, *Kochaspis*, and *Kochina*, are well represented. *Kootenia* is represented by 6 species. Specimens are numerous, particularly of *K. convoluta*, which occurs enrolled in several instances. Only two pygidia of *Olenoides* were found. *Poulsenia* also is well represented by excellent material including an entire individual. Finally the median trilobite form is represented by *Pachyaspis* and *Ehmaniella*. Although individuals are fairly abundant, the trilobites of this sort constitute a less conspicuous element of the fauna than usual for Middle Cambrian beds.

A clearer idea of the composition of the *Ptarmigania* fauna will result from a survey of the accompanying plates than from a lengthy discussion. When this is done, however, care must be exercised to view only the species that are positively assigned to the *Ptarmigania* fauna.

An interesting characteristic of the *Ptarmigania* fauna in the northern Wasatch region is the great development of granulosity. Nearly all species are granulose, and all have stronger ornamentation

of whatever kind than the same forms from adjacent areas. For instance, the only granulose *Kootenia* species known—and several hundred new species have been studied and described in manuscript—come from this area. Other trilobites behave in the same fashion. Even the smooth forms such as *Prozacanthoides* develop strong anastomosing lines on the elevated portions of the test.

Species from other localities have been described. Some are definitely from the Brigham and Langston formations. Others presumably represent the *Ptarmigania* fauna. Each will be readily determinable if localities are noted.

#### AGE OF THE PTARMIGANIA FAUNA

The *Ptarmigania* fauna is evidently of early Middle Cambrian age. Strong Lower Cambrian elements are held over, but a larger proportion of equally important Middle Cambrian elements are introduced, and new introductions must always outweigh holdovers. The constitution of the *Ptarmigania* fauna emphasizes anew the close relationship between the Lower and Middle Cambrian. As our knowledge increases it becomes ever clearer that there is no diastrophic break between Lower and Middle Cambrian, and the faunas likewise show no great change.

The close relationship to the *Albertella* fauna has been mentioned. On the one hand such genera as *Poulsenia*, *Dolichomctopsis*, *Prozacanthoides*, *Kootenia*, *Halcionella*, and *Wimanella* relate the *Ptarmigania* fauna to the upper Mount Whyte and Lower Cambrian faunas in the Appalachian region. On the other hand *Kochaspis*, *Kootenia*, and *Clavaspidella* are more characteristic of early Middle Cambrian, while such genera as *Pagetia*, *Oryctocephalus*, *Bathyriscus*, and *Olenoides* are more characteristic of later Middle Cambrian. The unique genera are, of course, left out of consideration, and the brachiopods are of no assistance.

*Glossopleura* is not in the *Ptarmigania* fauna at Two Mile Canyon. It is found throughout the lower half of the Middle Cambrian quite commonly and consequently can be expected in any of the faunas.

Summing up present evidence, it seems that the *Ptarmigania* fauna occurs in early Middle Cambrian beds, which are to be correlated with some part of the Ptarmigan, Ophir, and Howell formations in the west, and with the Rutledge of the Appalachians, and particularly with the Cape Wood formation of northwest Greenland. At the present stage of our studies the *Ptarmigania* fauna is most like that of the Comet shale in the Pioche district, Nevada.

## DESCRIPTION OF GENERA AND SPECIES

## BRACHIOPODA

## PATERINIDAE Schuchert

**MICROMITRA** Meek, 1873**MICROMITRA HAYDENI** Walcott

Plate 1, figs. 1-3

*Micromitra haydeni* WALCOTT, Smithsonian Misc. Coll., vol. 53, No. 3, p. 55, pl. 7, figs. 3, 3a, 1908; U. S. Geol. Surv. Mon. 51, p. 337, text fig. 20A-D, 1912.

Walcott's types are refigured by photographs.

Localities 54s, 59c.

*Holotype and paratypes*.—U.S.N.M. No. 51437.

**PATERINA BEECHER**, 1891**PATERINA HIRTA**, n. sp.

Plate 1, figs. 4-7

*Micromitra (Iphidella) pannula maladensis* WALCOTT (part), U. S. Geol. Surv. Mon. 51, p. 364, pl. 4, fig. 2a, 1912.

Part of the material assigned to *I. pannula maladensis* is more logically regarded as a species of *Paterina*. Many specimens have been found in addition to the one illustrated by Walcott.

*P. hirta* is characterized by strong growth lines. The ventral valve has a rather straight, long hinge line, and rises to the apex, which is half as high as the shell is wide. The dorsal valve is nearly semicircular in shape and much less convex than the high ventral valve. If the illustrations of *P. hirta* are compared with those of *I. maladensis* adjacent to them, the sharp distinction of surface features is easily seen. On the whole *P. hirta* is a rather wide form.

Locality 54s.

*Cotypes*.—U.S.N.M. Nos. 98567, 51465, 51450.

**IPHIDELLA** Walcott, 1905**IPHIDELLA MALADENSIS** Walcott

Plate 1, figs. 8-10

*Iphidella pannula maladensis* WALCOTT, Proc. U. S. Nat. Mus., vol. 28, p. 306, 1905.

*Micromitra (Iphidella) pannula maladensis* WALCOTT (part), U. S. Geol. Surv. Mon. 51, p. 364, pl. 4, figs. 2, 2d, 2e, 2g, 1912.

This species is restricted to specimens conspecific with the first one illustrated by Walcott. He also identified other specimens as

*I. pannula*. As Walcott pointed out, this species is characterized by the strong development of the surface pattern.

Locality 54s.

*Lectotype and paratypes*.—U.S.N.M. No. 51468 (except b).

ACROTRETIDAE Schuchert

ACROTHELE Linnarsson, 1876

ACROTHELE ARTEMIS Walcott

Plate I, figs. 19-22

*Acrothele artemis* WALCOTT, Smithsonian Misc. Coll., vol. 53, No. 3, p. 82, pl. 8, fig. 10, 1908; U. S. Geol. Surv. Mon. 51, p. 634, text fig. 54, 1912.

Walcott figured only one shell, a dorsal valve which he called a ventral valve. A ventral valve is here figured, and it shows that the apex is some distance from the margin.

Locality 54s.

*Holotype and plesiotypes*.—U.S.N.M. No. 51969.

ACROTHELE PARILIS, n. sp.

Plate I, figs. 23-25

*Acrothele subsidua* WALCOTT (part), U. S. Geol. Surv. Mon. 51, p. 656, pl. 60, figs. 1d, 1g, 1e, 1912.

Walcott confused this beautiful species with *A. subsidua*, which characterizes the Wheeler shale of the House Range. This happened because he failed to observe the exterior of the ventral valve.

*A. parilis* is a large, very beautifully marked form. The ventral valve is almost circular with the elevated apex nearly in the middle of the shell. The dorsal valve is less circular in outline, and in the specimen illustrated is slightly depressed in the middle. The surface is marked by concentric striae.

Compared to *A. artemis*, this species is larger and more circular in shape and the apex is nearer the center.

Locality 54s.

*Cotypes*.—U.S.N.M. No. 52014.

ACROTRETA Kutorga, 1848

ACROTRETA SULCATA Walcott

Plate I, figs. 11-14; plate 2, fig. 4

*Acrotreta idahocensis sulcata* WALCOTT, Proc. U. S. Nat. Mus., vol. 25, p. 588, 1902; U. S. Geol. Surv. Mon. 51, p. 690, pl. 65, fig. 5, 1912.

This species must be confined to the specimens from the type locality, which is on the strike, but south of, the place where Walcott

collected. The Spence shale form previously identified as *A. sulcata* has been described as *A. levata* Resser.

The plesiotypes add to our knowledge of the species by presenting illustrations of specimens showing the exterior features.

Near Paris, Bear River Range, and localities 54s, 19s.

*Holotype*.—U.S.N.M. No. 35275; plesiotypes, No. 52109.

**ACROTRETA EUCHARIS, n. sp.**

Plate 1, figs. 15-18

*Acrotreta pyridicula* WALCOTT (part) (not White), U. S. Geol. Surv. Mon. 51, p. 701, pl. 69, figs. 3-3f, 1912.

This is the commonest species of *Acrotreta* in this formation, being represented by many specimens both in the Wasatch Mountains and on the eastern slopes of Bear River Range. It is a small brachiopod, and since it does not exceed 2 mm. in diameter Walcott confused it with *A. pyridicula* White, an Upper Cambrian species from the Schellbourne Range, Nevada. As a matter of fact, Walcott's description of *A. pyridicula* is based on the Idaho specimens.

The photographs fail to bring out the height of these minute shells, which, however, is shown in Walcott's drawings. It will be observed that this species differs from *A. sulcata* because the median groove is very much shorter and the median septum of the dorsal valve also is shorter. In *A. eucharis* the apex is much closer to the posterior margin than in *A. sulcata*.

Localities 54s, 322, and 59f.

*Cotypes*.—U.S.N.M. Nos. 52147, 52150.

**ACROTHYRA Matthew, 1901**

**ACROTHYRA MINOR Walcott**

Plate 1, figs. 26-29

*Acrothyra minor* WALCOTT, Proc. U. S. Nat. Mus., vol. 28, p. 303, 1905; U. S. Geol. Surv. Mon. 51, p. 717, text fig. 59, pl. 76, figs. 4-4b, 1912.

Locality 54s.

*Holotype and paratypes*.—U.S.N.M. Nos. 52050, 52051.

**OBOLIDAE King**

**LINGULELLA SALTER, 1866**

**LINGULELLA EUCHARIS Resser**

Plate 1, figs. 30-32

*Lingulella eucharis* RESSER, Smithsonian Misc. Coll., vol. 97, No. 12, p. 5, pl. 1, figs. 1-3, 1939.

Walcott identified the specimens of this species with *L. desiderata*, *L. helena*, and *L. isse* but figured none of them.

It will be observed that the several valves illustrated here and in previous publications are within the normal variation of a species, consequently this form is identified with the Spence shale species. It has also been identified from localities near Brigham.

Localities 54s, 59f, and 55e.

*Plesiotypes*.—U.S.N.M. Nos. 51817, 51844.

BILLINGSSELLIDAE Schuchert

**WIMANELLA** Walcott, 1908

**WIMANELLA MALADENSIS**, n. sp.

Plate I, figs. 33-37

*Billingsella coloradoensis* WALCOTT (part), U. S. Geol. Surv. Mon. 51, p. 751, pl. 85, fig. 12, 1912.

Walcott figured the interior of an incomplete dorsal valve. Very good specimens are available showing that the species is a typical *Wimanella*, characterized by rather irregular but pronounced ribs. The beak extends considerably beyond the hinge line, and the species averages rather large.

Localities 54s and 20x.

*Cotypes*.—U.S.N.M. No. 34776.

GASTROPODA

PALAEACMAEIDAE Grabau and Shimer

**HELCIONELLA** Grabau and Shimer, 1909

**HELCIONELLA ARGUTA**, n. sp.

Plate I, figs. 38-41

This species is rather abundant. As may be seen from the illustrations, the shell is coiled into practically a complete whirl and expands rapidly. The cross section for most of the whirl is nearly circular but becomes flattened toward the mouth. The shell on the inner side of the whirl is nearly smooth but on the opposite side is divided by deep furrows into eight or more annulations, thus giving it a much more rugose appearance than most species in the genus. Each of these large rugosities carries a number of small transverse plications. In addition the shell is strongly striated lengthwise, the striae being slightly irregular in course, and varying slightly in strength.

Locality 54s.

*Cotypes*.—U.S.N.M. Nos. 98486a-d.

**HELCIONELLA AEQUA**, n. sp.

Plate 1, figs. 45-47

Several examples of a smooth form occur with *H. arguta*. This species is strongly curved but does not form a complete whirl. It expands very rapidly from the beak to the mouth. Viewed in cross section *H. aequa* is so flattened that both sides are nearly parallel. Faint irregular annulations may be seen in proper light. There are also rather weak longitudinal striations toward the outer margin of the whirl.

Locality 54s.

*Holotype*.—U.S.N.M. No. 98487.**HELCIONELLA BURLINGI**, n. sp.

Plate 1, figs. 42-44

At first it was thought that this form might be *H. arguta*, which it closely resembles in its coarse annulations, but, as seen in the illustrations, there is considerable difference in this respect. *H. burlingi* forms a little more than a complete whirl. In cross section it is rounded with flattened sides, and the annulations are wide but irregular on the outer margin of the whirl, becoming obsolescent on the inner face. The separating depressions are deeper on the sides than on the outer portion of the whirl, contrary to the usual development. The surface is marked by irregular striations parallel to the annulations, and in addition there are faint lengthwise striations.

Locality 59f.

*Cotypes*.—U.S.N.M. Nos. 98488a-c.

## HYOLITHIDAE Nicholson

**HYOLITHES** Eichwald, 1840**HYOLITHES PROLIXUS**, n. sp.

Plate 2, figs. 1-3

This is a large species without a carina. As shown by the photograph of the cross section the convex sides rise very steeply from the flat side and the convex side is rounded rather than sharply angular. On the flat side the usual striations are parallel to the lip but are developed irregularly. On the convex side the surface is also striated parallel to the lip except that the striae turn up toward the lateral angles, and they are closer together than on the flat side.

Locality 54s.

*Cotypes*.—U.S.N.M. Nos. 98489a-c.



## AGNOSTIA

AGNOSTIDAE M'Coy

**AGNOSTUS BRONGNIART**, 1822**AGNOSTUS LAUTUS**, n. sp.

Plate 2, figs. 16-18

This species is similar to the many others in the Middle Cambrian, of which *A. montis* is the best known. *A. lautus* is so much like other species in the Wasatch region that it was hoped it could be put into one of them. It is rather close to *A. brighamensis*, for the various furrows and proportions throughout are proportional in both species. But *A. lautus* does not have the even, semicircular outline of *A. brighamensis* because of the flattening of the front of the cranidium and of the sides and rear margins of the pygidium.

Locality 54s.

*Cotypes*.—U.S.N.M. Nos. 98490a-c.

## TRILOBITA

PAGETIDAE Kobayashi

**PAGETIA** Walcott, 1916**PAGETIA MALADENSIS**, n. sp.

Plate 2, figs. 4, 5

This is a rather smooth species of *Pagetia*. The cranidium has a long narrow glabella, well-defined eye lines, and a wide preglabellar area, as well as the usual rim structure. The species is of average size. Aside from the narrow glabella, two other features separate it from *P. clytia*, namely, the weakness of the median furrow across the preglabellar area and the absence of indentations on the brim. The pygidium, regarded as representative of the species, differs from that of *P. clytia* in the greater fusion of the pleural lobes carried to the point where furrows are no longer visible. There are the usual axial spines.

Locality 54s.

*Holotype and paratype*.—U.S.N.M. Nos. 98491a, b.**PAGETIA CLYTIA** Walcott

Plate 2, figs. 5-8

*Pagetia clytia* WALCOTT, Smithsonian Misc. Coll., vol. 64, No. 5, p. 408, pl. 67, figs. 2-2e, 1916.—RAYMOND, Mem. Connecticut Acad. Sci., vol. 7, p. 145, fig. 37, 1920.—RESSER, Smithsonian Misc. Coll., vol. 97, No. 12, p. 8, pl. 2, figs. 30-32, 1939.

Numerous well-preserved specimens permit close specific discrimination, which shows that this form is *P. clytia*, characteristic of the overlying Spence shale.

Locality 54s.

*Plesiotypes*.—U.S.N.M. Nos. 98492a-d.

#### ZACANTHOIDEA Swinnerton

#### PROZACANTHOIDES Resser, 1937

This genus is represented by five species in the collections from locality 54s and one from locality 59f, near Liberty. Unidentified species occur in the Langston of Blacksmith Fork. This represents a great expansion for the genus, and most of the species are represented by many specimens.

As the species are here set up heads and tails have been matched according to shape and surface ornamentation. One specimen retains the librigenes and part of the thorax.

Considerable similarity exists between the cranidia of *Prozacanthoides* and *Dolichometopsis* and *Ptarmigania*, and the pygidia of *Prozacanthoides* are sometimes difficult to tell from those of *Kochaspis* and even of *Kochiella*. Similar likenesses are observed among the hypostomata. In several respects *Prozacanthoides* lies between *Zacanthoides* and *Albertella*.

#### PROZACANTHOIDES ALATUS, n. sp.

Plate 3, figs. 10-12

This species is represented by several cranidia and pygidia, which have been selected on the basis of surface ornamentation and degree of fusion. The glabella is parallel-sided and rounded at the anterior angles, with a flattened curvature in front. The occipital furrow is straight and clearly defined but not deep. The occipital ring has a fairly large spine. Four pairs of glabellar furrows are faintly indicated. The fixigenes are confined to the palpebral lobes and at their widest point are a little more than half the width of the glabella. The eyes are very long, and the eye band is wide. The eyes extend from the anterior angles of the glabella outward at a considerable angle, with a nearly straight outline for about two-thirds their length. In the rear third the curvature increases very rapidly, and the rear portion of the eye lobe evidently overhangs the occipital furrow. The brim is simple without a rim, slightly concave, and upturned. The facial suture diverges at about the normal rate.

In the pygidium fusion is not complete as ribs appear in the pleural lobes. The axis is stout and long, terminating rather abruptly. Four rings and a terminal segment are defined by shallow axial furrows. As usual the anterior segment extends into stout spines directed straight back and a small pair of spines is developed on the second segment.

Locality 54s.

*Holotype and paratypes*.—U.S.N.M. Nos. 98493a-c.

**PROZACANTHOIDES LIBERTYENSIS, n. sp.**

Plate 3, figs. 13-15

It is possible that two species are included in the illustrated material, consequently one of the cranidia (fig. 13) is referred to the species with reservation. All the material is fragmentary, but it seems worth recording to show occurrence of *Prozacanthoides* in the Mill Creek section. The description is confined to the holotype pygidium.

The cranidium is parallel-sided, with a very slight expansion near the anterior end. The dorsal furrow is clearly defined, rounding off the anterior angles of the glabella. Palpebral lobes, which constitute the fixigenes, are less than half the width of the glabella and the eyes appear to have extended from the anterior pair of glabellar furrows to the occipital furrow, with a rather even but not very great curvature. Fusion is not complete in the pygidium and consequently several segments are apparent. The border seems to lack spines although it is wavy and has a strong indentation at the rear of the axis.

*P. libertyensis* differs from the species in Two Mile Canyon by its narrow brim and the pygidium, which has less detailed relief.

Locality 59f.

*Holotype and paratypes*.—U.S.N.M. Nos. 98494a-c.

**PROZACANTHOIDES DECOROSUS, n. sp.**

Plate 3, figs. 16-18

This species is represented by several examples of each part, and is a particularly well-formed species.

Four pairs of glabellar furrows are faintly indicated and the widened neck ring carries a short, slender spine. The width of the fixigenes is more than half that of the glabella, causing the glabella to be rather slender in proportion. The eyes are long and fairly evenly bowed with a slight decrease in curvature in the forward half.

The brim is simple and narrower than in most species. The associated hypostoma is illustrated in figure 18, together with another cranidium. The pygidium assigned to the species is not completely fused, as two segments are traceable, beside furrows on the third. The marginal spines are three in number. The pygidium is further characterized by a rather strong post-axial ridge and by the straight lateral margins.

*P. decorosus* is much like *P. alatus* in the large size of the eyes. It is distinguished quite readily by the more even curvature of the eye lobes.

Locality 54s.

*Holotype and paratypes*.—U.S.N.M. Nos. 98495a-c.

#### PROZACANTHOIDES EXILIS, n. sp.

Plate 3, figs. 19, 20

This species is represented by a considerable number of specimens. It is characterized by a rather broad glabella on which the furrows are indicated by faint depressions. The glabella is slightly keeled. The occipital furrow is considerably reduced, consisting of two deep elongated pits connected across the middle by a shallow furrow. The palpebral lobes at their greatest width equal exactly half the glabellar width. The eye bands are particularly wide, the eyes are rather evenly curved and set at a smaller angle to the dorsal furrow than in any other species. The brim is wide. The pygidium assigned to the species is narrow with a wide axis well fused with only one segment traceable. The axis is prominent because of its large size and because the narrow pleural lobes are slightly concave, rising from the dorsal furrow. The pygidium has a very small spine on the first segment. The surface is covered by fine anastomosing lines.

Locality 54s.

*Holotype and paratype*.—U.S.N.M. Nos. 98496a, b.

#### PROZACANTHOIDES AEQUUS, n. sp.

Plate 3, figs. 21-23

This species is represented by a number of cranidia, to which one pygidium had been assigned. It is characterized by low relief and a high degree of fusion. Several of the glabellar furrows are indicated by wide shallow depressions; likewise the occipital furrow. The widened neck ring is peculiarly marked by irregular striations radiated from the short occipital spine and covering the latter half of the ring. At their widest point the palpebral lobes are a little

more than half the width of the glabella, and are peculiar in that they are sunken below the dorsal furrow and eye band. The slightly upturned eye band is gently curved in the forward three-fourths and more sharply in the latter fourth. The brim is depressed next to the glabella and at the lateral angles in an irregular manner and is covered by coarse radiating anastomosing lines. The associated pygidium is also flat, with the axis standing above the pleural lobes. Like the fixigenes the pleural platforms are depressed below both the axis and the outer segment which forms a rim. The first segment extends into a spine.

The depression of the brim in front of the glabella and a similar downturning of the rear margins of the pygidial pleural lobes serve to distinguish this species from its associates.

Locality 54s.

*Holotype and paratypes*.—U.S.N.M. Nos. 98497a-c.

#### PROZACANTHOIDES OPTATUS, n. sp.

Plate 3, figs. 24-30

This is the commonest species of *Prozacanthoides* at the locality. It is represented by the best-preserved material and, moreover, has about average features for the group of species.

The glabella is parallel-sided, with the rear pair of furrows rather deeply impressed and the others represented by faint impressions. The occipital furrow is deep and the rings bear a spine, as well as two furrows parallel to the rear pair of glabellar furrows. Eyes are large, with their greatest curvature toward the rear, the palpebral lobes attaining their greatest width opposite the rear pair of glabellar furrows. At their widest point the palpebral lobes exceed half the glabellar width. Brim rather narrow; outline of the front margin of cranidium straighter than in most species. The posterolateral limbs end in intragenal spines.

Libragenes, attached to the holotype, are about as wide as the palpebral lobes, with long, slender, genal spines, which are slightly advanced. The strong rim is heavily striated and the ocular platforms are covered with a network of heavy anastomosing lines.

The pygidium assigned to the species is well fused, with a rather strongly tapered axis. Pleural segments are not entirely obliterated. The first segment extends into rather long, stout spines, and a second pair into small spines.

Locality 54s.

*Holotype and paratypes*.—U.S.N.M. Nos. 98498a, a'-2.

## BATHYURISCIDAE Richter

## BATHYURISCUS Meek, 1873

## BATHYURISCUS POLITUS, n. sp.

Plate 2, fig. 9

Present collections have yielded a single small *Bathyuriscus* pygidium, which belongs to the spined group of the genus. Even though there is but this one small tail, its generic position is certain.

The axis is cylindrical and extends to the rear margin, in cross section standing completely above the flat pleural lobes. Both the pleural grooves and the pleural furrows are retained, the latter ending in deep depressions next to the rim. The rim is narrow and extends into stout spines at the anterior angles.

Locality 54s.

*Holotype*.—U.S.N.M. No. 08499.

## POLIELLA Walcott, 1916

## POLIELLA WASATCHENSIS, n. sp.

Plate 13, fig. 16

An entire individual and a pygidium with the major portion of a thorax represent the species. It occurs in a shaly matrix, associated with *Alokistocarella brighamensis*. Its precise stratigraphic position is not known, and it is here included because of its association.

As a whole *P. wasatchensis* has the ovate shape characteristic of the genus. The glabella occupies the full length of the cranidium except for a narrow rim. It expands forward in the usual manner of the genus. Owing to the fact that the hypostoma has been pressed into the glabella, furrows and convexity are not determinable. The eyes are about normal in size and position. Anterior to the eyes the suture diverges and behind the eyes long narrow posterolateral limbs are formed. The fixigenes are almost eliminated at the anterior end of the eye. The librigenes are attached. They are simple, of normal size and have a narrow rim. Genal spines extend to about the fourth thoracic segment and are directed away from the thorax.

Thorax has nine segments. The rather long spines are spread out in open fashion.

The pygidium is fairly large, with the slender axis extending about three-fourths its length. A postaxial ridge continues to the indented rear border. Fusion has not wholly eliminated the pleural grooves. The pleural furrows are traceable almost to the margin across the slightly concave flattened border.

Locality 20x.

*Holotype*.—U.S.N.M. No. 98500.

## PTARMIGANIDAE, new family

**DOLICHOMETOPSIS** Poulsen, 1927

Poulsen described *Dolichometopsis* from cranidia, referring a single fragmentary pygidium to the type species. This pygidium, however, is doubtful, what there is of it pointing rather to *Kochiella*. Nearly complete specimens in the *Ptarmigania* fauna makes it practically certain that the pygidium of *Dolichometopsis* has a spinose margin, four spines to the side. These spines, which increase in size from front to back, may be longer than the pygidium or may be short and sharp-pointed. In no case have they been eliminated. The most characteristic feature of the pygidium, aside from the marginal spines, is the heavy spine on the first axial ring. The thorax seems to have seven segments.

Poulsen recognized the relationship of *Dolichometopsis* to *Albertella*. Its nearest relative clearly is *Ptarmigania*. In fact, it is not certain that the cranidia of the two genera can be separated in every case when the pygidium is lacking. In this paper arbitrary separations were necessary in several instances. On the whole *Ptarmigania* is more granulose than *Dolichometopsis*, but one cannot be sure that this criterion will hold at other localities for both have a granulated test.

**DOLICHOMETOPSIS LEPIDA**, n. sp.

Plate 3, figs. 31-33

This species is represented only by cranidia and a librigena. It is characterized by a long glabella, which expands slightly forward of the eyes. The usual four pairs of glabellar furrows are visible, and the occipital ring extends into a long stout spine. The fixigenae are confined to the palpebral lobes, which extend forward to the third pair of glabellar furrows and back to the occipital furrow. At the widest point they are just exactly half the width of the glabella and the eyes are moderately bowed with a nearby even curvature. As usual the rear end of the eye lobe overhangs the occipital furrow. The surface is granulose, the granules being rather numerous and evenly distributed. Anterior to the eyes the fixigenae form a flange about equal in width to the narrow concave brim, the latter being thickened and heavily striated on the elevated edge.

*D. lepida* has the longest glabella of the smaller forms.

Locality 54s:

*Holotype and paratype*.—U.S.N.M. Nos. 98501a, b.

**DOLICHOMETOPSIS STELLA, n. sp.**

Plate 3, fig. 37

This species is based on a single incomplete pygidium, which might well belong to some of the described cranidia, but it has been given a name because of its unique construction. Unfortunately the axis is broken away, but it clearly stood well above the convex pleural platforms. The pleural lobes rise slightly from the dorsal furrow but drop off rapidly to the border in their outer half. Four pleural furrows are visible, terminating in pits at their distal end. The unique feature of the pygidium is the length of the four marginal spines. The first pair is nearly as long as the pleuron to which it is attached. The remaining pairs increase in size and length rearward until the rear pair possibly equal the length of the pygidium. The surface is covered by small scalelike granulations, which become stronger toward the margins.

Locality 54s.

*Holotype*.—U.S.N.M. No. 98502.**DOLICHOMETOPSIS ALIA, n. sp.**

Plate 4, figs. 19-21

This is another well-represented species but only by cranidia.

The glabella expands forward at about the usual rate. The four pairs of glabellar furrows are faintly indicated but shallow. The neck ring is wide and contracts abruptly to a long, slender spine. The fixigenes at the widest point, which is at the rear end of the eye, exceed half the width of the glabella at the same point. The eyes are of moderate size and set at a considerable angle to the dorsal furrow. They are bowed rather evenly but the curvature is not great. Posterolateral limbs wider than usual in the genus, with a strong occipital furrow. Fixigenes anterior to the eyes at least four times the width of the brim. Brim confined to a very narrow upturned rim. Surface covered by scattered inconspicuous granules.

Locality 54s.

*Holotype*.—U.S.N.M. No. 98503; figured specimen, No. 98504.**DOLICHOMETOPSIS MEDIA, n. sp.**

Plate 4, figs. 11-12

This species is founded on a single pygidium. The axis is long and stout and unfortunately is broken off on top as the long spine was carried away by the matrix. Pleural lobes well fused, with four furrows visible, ending in the usual pits inside the border. Four



marginal spines increasing in size from the front to the rear are present. The surface is granulose, with the granules of moderate size and fairly crowded on the higher portions.

Locality 54s.

*Holotype*.—U.S.N.M. No. 98505.

**DOLICHOMETOPSIS COMIS, n.sp.**

Plate 4, figs. 22-24

This species is represented by several cranidia, and a pygidium assigned to it. The glabella expands very slightly and is definitely keeled, which feature extends into the occipital spine. It is further characterized by the failure of the occipital furrow to be deeply impressed across the median line. The palpebral lobes attain their greatest width opposite the first pair of glabellar furrows and this width is more than half the glabellar width at the same point. The eyes are evenly bowed and considerably curved, and anterior to the eye lines form rather wide flanges. Rinn narrow. The pygidium is characterized by a long, stout axis. The first axial ring is thickened and bears the usual long spine. Back of this, three other rings are traceable. On the pleural lobes only three ribs are noticeable, with the furrows terminating in pits as usual. The third pair of marginal spines is apparently reduced, while the fourth is rather large. Surface characterized by scattered granules and irregular ridges, both of which are faint.

Locality 54s.

*Holotype and paratype*.—U.S.N.M. Nos. 98506a, b.

**DOLICHOMETOPSIS POULSENI, n. sp.**

Plate 5, figs. 1-10

This species gives a clue to the association of cranidium and pygidium. It also serves for correlation between the Wasatch Mountains and Liberty Canyon in the Bear River Range. Unfortunately the specimens are fragmentary and the material is not abundant. Further collection at the locality should yield excellent specimens.

This is a large species in which the long glabella is practically parallel-sided. The usual furrows are visible, although broad and shallow. The occipital ring is exceptionally wide and extends into a long, erect spine. The fixigenes at their widest points are about half of the glabellar width. The eyes are long and fairly evenly bowed

with increasing curvature toward the rear. In cross section the cranidium is convex, but the cheeks are nearly flat, sloping a little downward from the dorsal furrow. Longitudinally the species is very convex with the posterolateral limbs depressed and curved down at their distal ends, and the anterior part of cranidium sloping down at almost right angles to the rear portion. The anterior fixigenes form a flange about twice as wide as the flat concave rim. Libragenes unknown. Several specimens retain thoracic segments, one of them as many as seven, which is possibly the total number. The pygidium is characterized by a prominent axis in which four rings are traceable, the first one being thickened and bearing a large axial spine. Four pairs of faint pleural furrows end in pits inside the border. A thickening along the rear margin delimits the first segment on the pleural lobes. The four marginal spines evidently increase in size from the front toward the rear. Surface marked by scattered granules on elevated portions.

Locality 59e, 54s.

*Holotype and paratypes*.—U.S.N.M. Nos. 98518a-c.

#### **DOLICHOMETOPSIS PROPINQUA, n. sp.**

Plate 5, figs. 11-13

This species is characterized by a long expanding glabella, which is narrowest at the second pair of furrows. The furrows are all shallow. The palpebral lobes are about half the glabellar width at the same point, and anterior to the eyes the fixigenes form a flange about three times the width of the rim. The eyes are long and not greatly bowed, except toward the rear. Rim narrow in front, widening toward the anterior angles to meet the flange. Eye lines present. The pygidium assigned to the species has a high axis, which terminates very abruptly in the rear and the pleura are fairly well indicated in the lobes. The four marginal spines increase only slightly in size toward the rear. Surface nearly smooth, but with scattered granulations.

Locality 54s.

*Holotype and paratype*.—U.S.N.M. Nos. 98508a, b.

#### **DOLICHOMETOPSIS GREGALIS, n. sp.**

Plate 6, figs. 1-4

This species is close to *D. poulscni*, with which it is associated. It is characterized by its large size and a practically parallel-sided

glabella. Furrows are wide and shallow, and when the test is exfoliated they are traceable entirely across the glabella. The dorsal furrow is shallow even though it is clearly defined. Evidently there is a large, erect, occipital spine. The palpebral lobes at their widest points are less than half the glabellar width. The eyes are long, with a slightly thickened band, but not greatly curved, and are set practically parallel with the dorsal furrow. Compared to most of the other species, this form is flat in cross section, with the glabella rising above the palpebral lobes in a flat curvature. The fixigenes are practically flat and almost horizontal. Longitudinally there is more curvature particularly because the anterior angles and posterolateral limbs are depressed. The brim is simple, concave with a slightly upturned rim. The pygidium is characterized by width of border and of the marginal spines. The latter increase in size rearward so that the last pair is large. The first segment is swollen as usual with a large spine, and the axis overhangs the border in the rear. Fusion is carried so far that most furrows are eliminated, and the border is wide.

Locality 59e.

*Holotype and paratype*.—U.S.N.M. Nos. 98509a, b.

#### DOLICHOMETOPSIS COMMUNIS, n. sp.

Plate 6, figs. 5-8

A number of specimens have been assigned to this species. It is characterized by a glabella that expands slightly in front of the eyes and has the usual shallow glabellar furrows. The distinctive characteristics of the species are found in the palpebral lobes, which are convex and narrow at their widest point, being only about one-third as wide as the glabella. Eyes very long and not greatly curved. In cross section the cranidium has a low-arched glabella and convex palpebral lobes, which also rise above the dorsal furrow. On the other hand, in longitudinal direction the cranidium is more highly arched, curving slightly except in the anterior fourth, which is sharply downturned. The associated pygidium is characterized by the usual features with the axis standing above the pleural lobes, but with only a shallow dorsal furrow. The pits at the ends of the pleural furrows are rather deep and the marginal spines nearly the same size throughout are arranged in a stellate fashion. The surface is covered by granules on the elevated portions, but the wide shallow furrows lack them.

Locality 54s.

*Holotype and paratype*.—U.S.N.M. Nos. 98510a, b.

**DOLICHOMETOPSIS MANSFIELDI, n. sp.**

Plate 6, figs. 11-16

This species is represented by a number of fragmentary specimens. It is nearest like *D. communis* in the narrowness of the palpebral lobes. The glabella does not expand very much and the furrows are all shallow, including the occipital furrow. The occipital ring is wide but its spine is slender. The palpebral lobes at their widest point are considerably less than half the glabellar width. The eyes are long, rather straight in the forward part, and more sharply curved to the rear. The librigenes are convex in cross section, but the glabella has little elevation. Longitudinally this species is not so highly convex, as may be seen from the side views. Test is smooth except for striations on the rim.

Locality 19s.

*Holotype and paratypes*.—U.S.N.M. Nos. 98511a-d.**DOLICHOMETOPSIS POTENS, n. sp.**

Plate 6, figs. 17-23

This species is represented by fragmentary material only but is quite distinctive because of the great width of the palpebral lobes and the practically smooth test. The glabella expands greatly in the anterior half. The furrows are developed as usual. The palpebral lobes are very wide, equaling nearly two-thirds the glabellar width at the same point. The occipital spine is stout. Anterior to the eyes the fixigenes form only a narrow flange, and the rim is very narrow. Fusion is carried far in the pygidium. The furrows are wide and shallow and the pits large but also shallow. The four marginal spines evidently increase in size rearward and likely are rather large. The peculiar feature of the pygidium is the wrinkling of the test on the higher parts.

Locality 54s.

*Holotype and paratypes*.—U.S.N.M. Nos. 98512a-e.**DOLICHOMETOPSIS GRAVIS, n. sp.**

Plate 7, figs. 6-11

This species is represented by several cranidia, and one pygidium has been assigned to it. It is characterized by the usual cranidial features, the glabella expanding slightly anterior to the eyes, and with four pairs of glabellar furrows, shallow except for the outer ends of the first pair, which are deeply impressed next to the dorsal furrow. This species evidently has a rather slender occipital spine. In cross

section the cranidium is convex. Longitudinally it is considerably more so, with a rather even curvature throughout. The palpebral lobes are just half the width of the glabella, and the eyes are of normal size and normal curvature. The palpebral furrow is shallow, but the eye band is fairly well defined. The brim is very narrow, expanding to meet the moderate flanges at the anterior angles. The pygidia assigned to the species has a rather high axis, abruptly terminated in the rear. The marginal spines increase rearward until the rear pair is quite long. Owing to the convexity and the granulations on the spines, there is some question regarding assignment of the pygidium. The cranidial surface seems to be nearly smooth.

Locality 54s.

*Holotype and paratypes.*—U.S.N.M. Nos. 98513a-c.

#### PTARMIGANIA<sup>3</sup> RAYMOND, 1928

*Ptarmigania* is represented by many species. Separation of *Ptarmigania* and *Dolichometopsis* can be made only when pygidia are available. In a species such as *P. exigua* the pygidial border has one definite and three blunt spines, the latter little more than irregularities of the edge. In most species the margin has been smoothed out much more, so that there is scarcely anything more than a slight production of the anterior angles to represent the spines. *Ptarmigania* also has a large axial spine on the first pygidial segment. Most of the species are granulated.

The cranidium of *Ptarmigania* resembles that of *Clavaspidella*, but the pygidium is differently constructed. Aside from the lack of an axial spine, *Clavaspidella* typically has a rounded triangular or semi-circular tail, while *Ptarmigania* has a transverse pygidium always wider than long.

#### PTARMIGANIA AURITA, n. sp.

Plate 3, figs. 35, 36

A single small cranidium is particularly marked by its nearly smooth surface and shallow glabellar furrows. The glabella expands forward from the first pair of glabellar furrows. The usual furrows are present but shallow, and the occipital spine evidently was large. The fixigenes, which are confined to the palpebral lobes, are about three-fourths the average glabellar width. The cranidium has considerable convexity longitudinally, and in cross section the glabella stands com-

<sup>3</sup>*Ptarmigania* was erroneously recorded in the bibliographic records as *Ptarmingia*. This error of spelling inadvertently got into the literature.

pletely above the fixigenes, rising on the sides rather rapidly reaching the greatest curvature near the median line but without producing a keel. The fixigenes are convex, sloping down rather rapidly to a broad palpebral furrow. The wide eye band rises from the furrow. The eyes are of moderate length, extending from the front glabellar furrow to a point forward of the occipital furrow. Anterior to the eyes the fixigenes form a small flange which joins the narrow brim. The brim consists of a narrow rim, slightly upturned. Surface finely granulose.

Locality 54s.

*Holotype*.—U.S.N.M. No. 98514.

**PTARMIGANIA EXIGUA, n. sp.**

Plate 4, figs. 1-10

This is a common species, being represented by one cephalon, many cranidia, librigenes, and pygidia.

The glabella is long, expanding forward from the occipital furrow at an even rate to rounded anterior angles. The usual sets of furrows are deeply impressed. In cross section the species is convex, and the evenly arched glabella is above the dorsal furrow. The fixigenes are only slightly convex and have a horizontal position. Longitudinally the cranidium is very convex. The palpebral lobe, which is the fixigene, is about two-thirds the width of the glabella at that point. The occipital spine is stout and long, and the posterolateral limbs are long. The eyes extend from a little forward of the posterolateral limbs to the third pair of glabellar furrows and are set at a considerable angle to the dorsal furrow. The eye band is wide and slightly upturned. Eye lines strong. Anterior fixigene fairly wide and turned down at the outer angles. Brim simple, convex with the anterior margin strongly striated. Fixigene, attached to the holotype, highly convex and placed almost vertical to the palpebral lobe. Outer edge striated to correspond to rim and increasingly upturned toward the front. Genal spines long.

The pygidium is characterized by a stout axis in which two rings and a large terminal segment are defined, the anterior ring carrying a large spine. Three pleura visible on the platforms, but on the wide border four may be discerned. Each pleuron extends into a short blunt marginal spine.

Surface of the entire test granulose with the granules fairly evenly distributed except in the furrows.

Locality 54s.

*Holotype and paratypes*.—U.S.N.M. Nos. 98515a-f.

**PTARMIGANIA NATALIS, n. sp.**

Plate 4, figs. 13-18

This is perhaps the most abundant species, but a pygidium has not been located for it. The glabella is long, expanding rather evenly but slowly forward with the usual four pairs of furrows visible. The neck spine is long and extends up from the neck ring. The fixigenes are confined largely to the palpebral lobes and at their widest points are almost exactly equal to half of the glabellar width at the same point. The eyes are long, extending from the occipital furrow to the third pair of glabellar furrows, and the eye band is continued to the glabella by a large, wide eye ridge. The eyes are evenly bowed, increasing their curvature slightly toward the rear. Forward of the eyes the fixigenes form a flange about twice the width of the brim. Brim confined to a rim slightly upturned and striated. The fixigenes are very convex with the platform setting at a  $60^\circ$  angle to the border, thus sloping steeply down from the eye. Surface evenly granulose except in the depths of the furrows.

Locality 54s.

*Holotype and paratypes*.—U.S.N.M. Nos. 98516a-d.**PTARMIGANIA ORNATA, n. sp.**

Plate 4, figs. 25-32

This is another common species represented by numerous cranidia and librigenes, but no pygidium has been located. The glabella is nearly parallel-sided and long, with the usual four pairs of furrows and the occipital furrow is clearly shown. The cranidium is highly arched longitudinally with a fairly even curvature. In cross section the glabella is quite convex, also with an even curvature. The librigenes rise very steeply from the dorsal furrow before they turn over to the eye lobes as is shown in figure 30. The occipital spine is long and erect. The eyes are rather strongly bowed and the palpebral lobes at their widest points are less than half the glabellar width. This is perhaps the most granulose species, the granules being large and numerous, wanting only in the depths of the furrows.

Locality 54s.

*Holotype and paratypes*.—U.S.N.M. Nos. 98507a-f.**PTARMIGANIA AGRESTIS, n. sp.**

Plate 7, figs. 1, 2

This species is represented by several cranidia. Pygidia have been assigned to it but are not illustrated because of uncertain relationship.

The holotype is characterized by a cranidium that expands at about the usual rate and has the usual furrows. The second pair of glabellar furrows is somewhat distinctive in that it consists of deep narrow slots, and the rear pair is somewhat irregular in its course. In cross section this is quite a flat species with the glabella arched above the dorsal furrow and the palpebral lobes flat on top, sloping off at the outer edges. Longitudinally, there is greater curvature, fairly steep in front, but otherwise gentle. The palpebral lobes at their widest point are half the width of the glabella. The eye bands are wide and the eyes are of moderate length and not greatly curved. The fixigenes form a narrow flange anterior to the eyes and there is almost no rim. The surface is smooth, except for irregular puckering of the test near the occipital spine.

Locality 54s.

*Holotype*.—U.S.N.M. No. 98517.

**PTARMIGANIA ALTILIS, n. sp.**

Plate 7, figs. 3-5

This relatively small species is represented by several cranidia and one librigena. The glabella expands in normal fashion, and while the usual glabellar furrows are present, they are excessively shallow, except for the anterior pair which is quite deep due to a swelling of the glabellar surface near it. The head is nearly flat in cross section but considerably arched longitudinally. The eyes are about normal in length and considerably curved toward the rear. At their widest point the palpebral lobes are slightly less than half the glabellar width. The eye bands are clearly differentiated, but the palpebral furrow is shallow. The test is smooth, except for linear rugosities on the occipital ring. Anterior to the eye the fixigenes form relatively wide downturned flanges, and the rim is very narrow.

Locality 54s.

*Holotype and paratype*.—U.S.N.M. Nos. 98519a, b.

**PTARMIGANIA SOBRINA, n. sp.**

Plate 7, figs. 12-15

One cranidium and several pygidia have been associated to form the species. A librigena lies near the pygidium and is thought to belong with it. This species is characterized by a parallel-sided, relatively long and narrow glabella. In cross section the glabella is arched to a slight keel, and the palpebral lobes are quite convex, being rolled over on their outer edges. Longitudinally this species has considerable



elevation attained by an even curvature. The glabellar and occipital furrows are shallow, and the occipital spine is heavy and long. The palpebral lobes are just half the glabellar width at their widest point. The associated pygidium is well fused, although both the furrows and grooves are visible. The anterior portion of each pleuron is elevated into a narrow ridge, particularly well shown in the side view of the pygidium. The border is rather even, forming a slight angle near the anterior corner and another toward the rear, the remnants of the marginal spines. A small hypostoma lying near the cranium is thought to represent the species. Surface appears to have been fairly smooth.

Locality 54s.

*Holotype and paratype*.—U.S.N.M. Nos. 98520a, b.

#### PTARMIGANIA GERMANA, n. sp.

Plate 7, figs. 16-20

This is a relatively small species and is represented by several cranidia and pygidia. The glabella expands considerably forward and the usual furrows are visible but shallow. The occipital spine evidently is rather slender. This species is quite flat in cross section and only gently curved longitudinally. The eyes are long, gently curved, with the eye band well defined. The pygidium is well fused, so much so that most of the furrows and grooves are eliminated. The anterior furrow is visible and the groove between the first and second pleura is well shown next to the dorsal furrow, because of the ridging on both sides of it. The rear margin is sharply indented in the center and a very short spine is present at the anterior angles.

Locality 54s.

*Holotype and paratypes*.—U.S.N.M. Nos. 98521a-c.

#### PTARMIGANIA DIGNATA, n. sp.

Plate 8, figs. 1-7

This is a well-represented species. The glabella expands forward throughout its length; at an increasing rate in the anterior third. The furrows are shallow throughout. The occipital spine is of about medium size and stands erect. The palpebral lobes are about half the width of the glabella at the same point and are particularly characterized by high relief. A ridge parallels the palpebral furrow, thus giving rise to the distinctive feature of the species. The palpebral furrow is broad and shallow and the eye bands narrow. The eyes are of medium size and set at a considerable angle to the dorsal furrow. The flanges

are narrow and the brim practically wanting across the front of the glabella. The librigenae has a rather wide ocular platform and is not very convex. A heavy, thickened border extends into a long genal spine. The associated pygidium is well fused, although three pleural furrows are still visible. The margin is nearly even with faintly defined waves to represent the marginal spines. Surface granulose on the highest points and toward the margins marked by heavy irregular lines.

Locality 54s.

*Holotype and paratypes*.—U.S.N.M. Nos. 98522a-d.

**PTARMIGANIA**, sp. undet.

Plate 3, fig. 34

A minute cranidium, the characters of which are well shown by the illustration, does not fit the recognized species. It may well represent a young stage, but if so the species to which it belongs is not determinable, since there is no ornamentation to assist.

Locality 54s.

*Figured specimen*.—U.S.N.M. No. 98523.

**GLOSSOPLEURA** Poulsen, 1927

**GLOSSOPLEURA PRONA**, n. sp.

Plate 8, figs. 11-14

This species is characterized by its smoothness and the flatness of the pygidium. The eyes are large, and the glabella expands only slightly anterior to the forward end of the eyes.

The pygidium is flat, with a faint dorsal furrow. Pleural furrows are faintly visible between the axis and the wide flat border.

This species is similar to *G. bion* but the pygidium is flatter and the cranidium has less brim.

Localities 55p, 55q.

*Holotype and paratype*.—U.S.N.M. Nos. 98524a, b.

**GLOSSOPLEURA ARRECTA**, n. sp.

Plate 8, figs. 8-10

This species is associated with *G. prona* but contrasts strongly with it because the pygidium is highly arched. This arching is rather even so that the dorsal furrow becomes shallow. Longitudinally the axis is arched, the declivity at the rear being very steep. Pleural grooves are practically absent.

Localities 55p, 55q.

*Holotype and paratype*.—U.S.N.M. Nos. 98525a, b.

**CLAVASPIDELLA** Poulsen, 1927**CLAVASPIDELLA WASATCHENSIS**, n. sp.

Plate 8, figs. 15-20

Numerous pygidia, but only one cranidium, of this species have been found. Parts of other cranidia are to be seen on some of the larger pieces of rock.

The glabella expands rapidly in the anterior third and is nearly parallel-sided opposite the palpebral lobes. The occipital and rear pair of furrows are well impressed, but the remaining furrows are barely visible. There is a small node of the neck ring. Anterior to the eyes the facial suture diverges rapidly, but the flanges thereby produced increase little in width toward the anterior angles. Brim consisting of a very narrow rim only. Palpebral lobes are narrow, being less than half the glabellar width at the same point, and they maintain their width throughout nearly all of their length. The pygidium is typical of the genus with its narrow axis on which four rings are traceable, beside the long tapering rear segment. The pleural lobes slope down to a slightly flattened border across which the pleural furrows extend to the margins. Pleural grooves are faintly visible. The librigenae has a wide concave border, which extends into a long, broad, genal spine. The surface is covered with very fine granules and as usual, when the test is exfoliated, is punctate.

Locality 20x.

*Holotype ad paratypes*.—U.S.N.M. Nos. 68526a-d.

**CLAVASPIDELLA EXCAVATA**, n. sp.

Plate 9, figs. 1-6

This beautiful species is represented by a number of specimens. The glabella is long and narrow, expanding in the usual manner, with ordinary development of glabellar and occipital furrows. In cross section there is little convexity, except that the anterior angles and the posterolateral limbs are depressed. Longitudinally curvature is confined to the anterior third of the glabella. The palpebral lobes at their widest point are less than half the glabellar width. They rise somewhat from the dorsal furrow but do not have great convexity. The palpebral furrow is clearly defined. The eye is of normal size and position. The suture anterior to the eye diverges rapidly to form triangular anterior angles. The associated hypostoma has the large heavy bar characteristic of the genus. The pygidium is quite distinctive both in its relief and development of furrows. The axis has

about the usual proportions and stands above the pleural lobes. Both the pleural furrows and pleural grooves are deep; the anterior ones extending to the margin and those near the rear end of the axis ending abruptly some distance from the margin. The pleural platforms are small and the outer edges are upturned, so that the entire pygidium appears concave.

Locality 59c.

*Holotype and paratypes*.—U.S.N.M. Nos. 98527a-d.

ORYCTOCEPHALIDAE Beecher

**ORYCTOCEPHALITES**, n. gen.

Small trilobites related to *Oryctocephalus*. The glabella is long, extending the full length of the cranidium, expanding forward. The occipital furrow is deeply impressed and three pairs of glabellar furrows are present. None of them reach to the dorsal furrow. The rear pair consists of two elongated pits connected by a shallow furrow across the median line, while the forward pairs consist merely of elongated pits. The dorsal furrow is deep. The fixigenes average less than half the width of the glabella. The eyes are large, extending from the occipital furrow forward a little more than half the length of the glabella and are set at a considerable angle to the course of the dorsal furrow. Weak eye lines connect their anterior ends with the dorsal furrow. These eye lines pass forward parallel to the strongly curved anterior margin, reaching the glabella forward of the anterior pair of furrows. The brim is confined to a narrow upturned rim. The pygidium is well fused in the anterior portion. Its axis is rather prominent, contracting rather rapidly toward the rear and extending somewhat more than two-thirds the length of the pygidium. Four axial rings and a terminal segment are delimited. The pleural grooves are deep, and the pleural furrows are traceable, becoming better defined toward the rear so that the segmentation of the rear portion of the pygidium can be clearly traced. Five pairs of marginal furrows are present, and these increase in size from the anterior angles to the fourth spine, which is very large, while the fifth is reduced to small, slender points. A wide, flat, postaxial ridge extends to the rear margin.

This genus differs from *Oryctocephalus* in the expanded glabella, which extends forward beyond the fixigenes, at the anterior angles, the reduction of the forward glabellar furrows to pits, the lesser development of the eye line, and the more posterior position of the eyes. In the pygidium the difference is expressed by a greater degree

of fusion and a greater convexity, in keeping with the greater convexity of the cranidium.

*Genotype*.—*O. typicalis*, n. sp.

**ORYCTOCEPHALITES TYPICALIS**, n. sp.

Plate 3, figs. 1-6

The generic description and the illustrations present all the essential characteristics of this species.

Locality 54s.

*Holotype and paratypes*.—U.S.N.M. Nos. 98528a-f.

**ORYCTOCEPHALUS** Reed, 1898

**ORYCTOCEPHALUS MALADENSIS**, n. sp.

Plate 3, figs. 7-9

About 75 cranidia, but part of only one pygidium, have been found in the collections. This species is wholly typical of the genus, as the cranidium has a quadrate outline and a long parallel-sided glabella, with three pairs of furrows clearly indicated. The eye lines are prominent, and the rim is narrow, particularly in front of the glabella. The eyes are large and set practically parallel to the dorsal furrow. The fragment of the pygidium shows that segmentation is normally developed and no doubt there are long slender marginal spines.

*O. maladensis* is very much like *O. walcotti* of the Spence shale. It averages smaller. Difference is noticeable in relief which is discounted by compression of the Spence shale. The chief difference is in the brim, where *O. maladensis* has a wider space between the eye lines and the anterior furrow on the anterior fixigenes, and also has a thickened instead of a flat rim.

Locality 54s.

*Holotype and paratypes*.—U.S.N.M. Nos. 98529a-c.

**TONKINELLA** Mansuy, 1916

**TONKINELLA IDAHOENSIS**, n. sp.

Plate 2, fig. 10

Closely associated with *Taxiowra* and *Pagetia* is a single small pygidium, which at present can be referred only to *Tonkinella*. This pygidium is rather convex but flattened on top. Fusion has almost eliminated the dorsal furrow and pleural grooves and furrows. All are visible as shallow marks on the test.

Locality 54s.

*Holotype*.—U.S.N.M. No. 98530.

## KOOTENIDAE, new family

OLENOIDES Meek, 1877

OLENOIDES MALADENSIS, n. sp.

Plate 10, figs. 27, 28

Only pygidia have been found. The cranidia are difficult to distinguish from *Kootenia* but none in the collection seem to be large enough to warrant consideration as *O. maladensis*.

The axis is long and stout, terminating abruptly at the marginal furrow. Four axial rings and a terminal segment are clearly defined by rather broad furrows. Four pleura are clearly defined, each ending in a long, recurved spine. The rear pleuron is flexed back around the rear lobe of the axis. The anterior axial rings have blunt spines. Surface very granulose.

Locality 54s.

*Holotype and paratype*.—U.S.N.M. Nos. 98531a, b.

KOOTENIA Walcott, 1888

KOOTENIA CONVOLUTA, n. sp.

Plate 10, figs. 1-11

This species is very abundant, and the material includes several enrolled examples that are rare in the Cambrian. *K. convoluta* and associated species are about the only species of *Kootenia* that are granulated. However, it will be noted that there is a tendency toward lining and scaly structures rather than rounded granules.

Glabella rectangular, without trace of glabellar furrows. Occipital furrow deep, neck ring extended into a short, rapidly tapering spine. Anterior pits in the dorsal furrow are deep, which consequently narrows the glabella at this point. Glabella extends beyond the anterior angles. Anterior furrow increases in depth and turns somewhat backward beyond the corners of the glabella, thus widening and making concave the rim and at the same time leaving a steep escarpment behind it, which takes the place of the eye line. Front outline of the head curved with the slight recession in the center. Fixigenes and eyes about average for the genus.

Libragenes small and narrow; the thorax has seven segments.

Pygidium semicircular, axis arched, and divided into three rings and a large rear segment by three axial furrows, which are more deeply impressed on the sides than in the middle. Pleura well fused but with pleural furrows in the anterior portion indicated by short, deep depressions. A well-defined flattened rim is delimited by a

shallow marginal furrow. The five pairs of marginal spines are flat, moderately long and slender, the anterior being the shortest, the second somewhat larger, and the remaining three still larger and about equal in size.

The surface of the cranium is marked by strong striae on the frontal rim. On the sloping parts of the cranium irregular lines pass into more or less definite granules, except in the furrows. The pygidium is covered with granulations, which tend to become scaly on the marginal spines.

Localities 54s, 59f.

*Holotype and paratypes*.—U.S.N.M. Nos. 98532a-c.

#### KOOTENIA MALADENSIS, n. sp.

Plate 10, figs. 12-15

Associated with *K. convoluta* and *K. granulosa* are several entirely smooth specimens of both crania and pygidia. Aside from lack of granulation the cranium is much like that of *K. granulosa*, except that the rim in front of the glabella is narrower. Besides the smooth test the pygidium is also somewhat flatter as a whole, and the ribs are less conspicuous than in the other species.

Locality 54s.

*Holotype and paratype*.—U.S.N.M. Nos. 98533a, b.

#### KOOTENIA GRANULOSA, n. sp.

Plate 10, figs. 16-20

This is a small, very beautiful species associated with *K. convoluta* from which it differs in that the glabella is more quadrate in front owing to shallower dorsal pits. The frontal portion of the rim is slightly wider. *K. granulosa* is particularly characterized by the rounded granules, which do not tend to form ridges.

The pygidium referred to *K. granulosa* differs from that of *K. convoluta* in having slightly deeper pleural furrows, less fusion of the segments, less rapidly tapering marginal spines. It also has the characteristic granulose surface.

Locality 54s.

*Holotype and paratypes*.—U.S.N.M. Nos. 98534a-c.

#### KOOTENIA NITIDA, n. sp.

Plate 10, fig. 21

This species is founded on a single cranium and is closely allied to *K. granulosa*. *K. nitida* differs chiefly in its narrower glabella with

somewhat stronger glabellar furrows. Likewise the dorsal furrows are deeper, particularly toward the front, which causes the rim to be more sharply upturned near the anterior angles.

Locality 54s.

*Holotype*.—U.S.N.M. No. 98535.

**KOOTENIA LIBERTYENSIS, n. sp.**

Plate 9, figs. 7-9

This species is represented by fragmentary material and is associated with *Clavaspidella excavata*. The cranidium assigned to it is somewhat doubtful, as it lies next to a fragment of *K. venusta* and may be representative of that species rather than of *K. libertyensis*. The cranidium is selected because of its surface markings and smaller size. The cranidium is characterized by a glabella, which is rounded in front, a large upright occipital spine, and a narrow striated rim. The anterior outline is considerably curved due to the rearward position of the anterior angles. The pygidium has six marginal spines. It is well fused, with the axis clearly defined and with the pleural grooves faintly visible. The marginal furrow is wide and prominent because of the change in slope. The spines are rather long and slender. The higher parts of the surface are marked by irregular elongate granulations.

Locality 59c.

*Holotype and paratypes*.—U.S.N.M. Nos. 98536a-c.

**KOOTENIA VENUSTA, n. sp.**

Plate 9, figs. 10, 11

This species, associated with *K. libertyensis*, is represented by fragmentary material. Only incomplete cranidia have been assigned to the species, one of which is illustrated. Compared to *K. libertyensis*, this cranidium has a long straight anterior margin. The glabella is relatively wider and also flatter. The pygidium is characterized by seven marginal spines, the rear pair of which are very small and close to the median point. The other spines are long and slender. Fusion has not completely eliminated the pleural grooves. Five axial rings and terminal segments are well defined in the convex axis. The anterior ring has a peculiar fold, possibly to be interpreted as an incipient spine. Surface smooth, except on the marginal spines where the usual scaly structure is developed.

Locality 59c.

*Holotype and paratype*.—U.S.N.M. Nos. 98537a, b.



**KOOTENIA MENDOSA, n. sp.**

Plate 9, figs. 14-18

This is a fairly common species, being represented by several cranidia and pygidia, none of which is very well preserved. As shown by the illustrations it is associated with *Wimabella maladensis* and with *Clavaspidella wasatchensis*.

The cranidium is characterized by a large prominent glabella which extends well forward beyond the anterior angles. It tapers somewhat forward. Pits at the anterior angles of the dorsal furrow strongly restrict the glabella at that point. Viewed from the front the cranidium is very convex with the glabella sharply curved. In that view the constriction in the forward end of the glabella is particularly noticeable. The pygidium is peculiar in several respects. The axis is long and of normal width, with the usual segments. The pleural lobes are well fused, although the pleural grooves are still visible. The border is of normal width. The outstanding peculiarity is the reduction of the marginal spines to short spines on the first and second segments and back of that to a slight waviness in the margin, becoming a smooth even outline in the rear.

Locality 20x.

*Holotype and paratypes*.—U.S.N.M. Nos. 98538a-c.**KOOTENIA GERMANA, n. sp.**

Plate 9, figs. 19-24

This is a small species associated with *K. mendosa*. The glabella is of normal size and composition, being rather highly arched in both directions. The pygidium has six small, tapering marginal spines.

Locality 20x.

*Holotype and paratype*.—U.S.N.M. Nos. 98539a-d.**KOOTENIA ACICULARIS, n. sp.**

Plate 10, figs. 24-26

One pygidium among the many *Kootenia* species at Two Mile Canyon has sharp spines. A very small cranidium, which also does not seem to belong with any other species is tentatively assigned to the species. The pygidium is characterized by the usual long cylindrical axis. Fusion has been nearly sufficient to eliminate the pleural grooves. A distinctive feature of the species is the extension of the pleural furrows across the border. There are six pairs of very slender marginal spines. The surface is smooth.

The small cranidium, which is illustrated, has a forward expanding glabella but is otherwise normal.

Locality 54s.

*Holotype and paratype*.—U.S.N.M. Nos. 98540a, b.

**KOOTENIA BEARENSIS, n. sp.**

Plate 10, figs. 22, 23

This species is founded on the pygidium. It has five spines, for which reason it resembles *K. convoluta*. It differs from that species because of its nearly smooth test. The marginal spines are long and the third pair is quite large.

Locality 19x.

*Holotype*.—U.S.N.M. No. 98541.

**KOOTENIA PECTENOIDES, n. sp.**

Plate 9, figs. 12, 13

The species is known only from the pygidium. It belongs to the *K. serrata* group. Fusion is carried to the extreme, so that the pleural grooves are eliminated and the pleural furrows shallow. The five marginal spines are blunt but terminate in sharp points.

Locality 55q.

*Holotype*.—U.S.N.M. No. 98542.

**KOOTENIA BREVISPIINA, n. sp.**

Plate 11, figs. 1-4

This is a large species represented by four pygidia. An incomplete cranidium has been placed with these pygidia, but it is too imperfectly preserved to illustrate.

The pygidium is characterized by a wide stout axis and great convexity. Only a few segments are visible on the axis and pleural lobes. The pleural grooves are completely eliminated, and the pleural furrows are shallow but broad, terminating in the broad shallow marginal furrow. There are six short marginal spines, which give the pygidium a serrate edge. Fine granulations occur in the elevated portions, and as usual the marginal spines are scaly.

Owing to the blunt marginal spines this species resembles *K. pectenoides*.

Locality 54s.

*Holotype and paratype*.—U.S.N.M. Nos. 98543a, b.

## ALOKISTOCARIDAE, new family

ALOKISTOCARE Lorenz, 1906

## ALOKISTOCARE EUCHARE, n. sp.

Plate 2, figs. 11, 12

A single cranidium, in contrast with the great development in the superjacent Spence shale represents the genus in the *Ptarmigania* beds. It is typical in its proportions and relief. The glabella tapers to a rounded front, which is separated from a medially swollen preglabellar area by a deepened anterior dorsal furrow. The surface of the glabella is not so well preserved, but the shallow furrows seem to be rather wide. The glabella occupies about half the cranidial length. At the eyes, which are rather small and situated behind the cranidial midpoint, the fixigenes are about as wide as the glabella. The eye lines are strong, arising near the anterior glabellar angles. The brim is wide and generally concave, with the middle portion of the preglabellar area considerably swollen. The outer third is upturned as a flat rim. Back of the anterior furrow thus formed, a ridge crosses the brim parallel to the anterior margin. Brim vertically striated.

Locality 54s.

*Holotype*.—U.S.N.M. No. 98544.

## ALOKISTOCARE EUZONA, n. sp.

Plate 12, figs. 4, 5

A single cranidium represents this species, which seems to be typical in its development. The glabella tapers forward at about the average rate and several pairs of glabellar furrows are faintly indicated by indentations near the dorsal furrow. The glabella is arched above the dorsal furrow with moderate convexity. The glabella, exclusive of the occipital ring, occupies about half the cranidial length. The fixigenes are just about half the glabellar width and rise considerably from the dorsal furrow. As usual the brim is wide and long, because the anterior facial suture diverges. Next to the anterior dorsal furrow the preglabellar area rises rather abruptly and then is gently concave to the front margin. Because the anterior angles are depressed, the slope of the preglabellar area becomes much steeper toward the anterior angles. Eye lines present. Eyes of moderate size, situated behind the midpoint of the glabella. No brim developed but the doublure shows as the usual impression on the brim. Brim vertically marked by anastomosing lines.

*A. euzona* is closely allied to *A. euchare* from Two Mile Canyon.

Locality 59f.

*Holotype*.—U.S.N.M. No. 98545.

**ALOKISTOCARE GLOBATUM, n. sp.**

Plate 12, figs. 10, 11

Only the one cranidium has been found, and it is not fully typical of the genus. The glabella tapers and is fully two-thirds the length of the cranidium. It lacks glabellar furrows, although faint irregularities occur along the dorsal furrow. The wide, shallow, occipital furrow is nearly interrupted by the slight keel that extends into the occipital ring. The latter has a small node. The dorsal furrow is wide and shallow but clearly defined to a point anterior to the eyes. From that point forward there is a rather unique spreading and coalescence of the glabella into the preglabellar area. The dorsal furrow is traceable entirely around the front of the glabella but is irregular. In other words the anterior part of the glabella fans out and joins the brim in an irregular manner. This feature is rare in ordinary trilobites but is found in such forms as *Bailiella* and *Harpes*. The librigenes are convex, rising abruptly from the dorsal furrow and then sloping down with little curvature at a considerable angle from the eye. The eye is situated well below the level of the dorsal furrow. The eyes are small and occupy about the midpoint of the cranidium. Anterior to the eyes the facial suture diverges slightly. The brim is wide and consists of a wide preglabellar area, which slopes downward, and a narrow rim, which rises to a horizontal position. The preglabellar area is covered by vertical and anastomosing lines, but the rest of the test appears to be smooth.

Locality 55p.

*Holotype*.—U.S.N.M. No. 98546.**ALOKISTOCARELLA Resser, 1938****ALOKISTOCARELLA OCCIDENS, n. sp.**

Plate 2, figs. 13, 14

Two cranidia represent *Alokistocarella*. The species is characterized by a rather large subconical glabella, truncated in front. Including the occipital ring it is about two-thirds the cranidial length. Three pairs of glabellar furrows show faintly. The fixigenes opposite the eyes are about half the width of the glabella at the same point. The brim is wide, concave, and is turned up rather abruptly but lacks a rim. The brim is faintly striated vertically and the surface of the holotype is punctate.

Locality 54s.

*Holotype*.—U.S.N.M. No. 98547.

**ALOKISTOCARELLA BRIGHAMENSIS, n. sp.**

Plate 13, figs. 17, 18

Several nearly complete specimens are in hand. Unfortunately none of them preserve the pygidium. The cranidium is simple in construction, with a tapering glabella, rounded in front. Glabellar furrows are not shown. Brim concave, with a rim delimited in proper light more by means of change of slope than by an anterior furrow. Fixigenes are simple, averaging about two-thirds the glabellar width. Eye lines present. Eyes small, situated somewhat behind the middle of the cranidium.

The holotype retains about 16 thoracic segments, which is likely close to the total.

Localities 55e, 20x.

*Holotype and paratype*.—U.S.N.M. Nos. 98549, 98548.

**KOCHINA Resser, 1935****KOCHINA VENUSTA, n. sp.**

Plate 6, figs. 9, 10

This species is based on a cranidium that seems to be fully typical of *Kochina*. The glabella tapers and attains a length of a little more than half the cranidium. Three pairs of furrows are visible, and the occipital ring bears a small node. In cross section the cranidium is rather flat across the palpebral lobes but becomes quite convex in front. Longitudinally there is little curvature except in the brim. The fixigenes average about three-fourths the glabellar width. Eye lines present. Eyes of normal size, situated just behind the midpoint of the glabella. Brim wide, with a wide rim that expands in the middle. Surface finely granulose, overlain by scattered larger granules on the glabella and fixigenes, and by vertical lines on the preglabellar area.

Locality 54s.

*Holotype*.—U.S.N.M. No. 98550.

**KOCHINA VESTITA, n. sp.**

Plate 12, figs. 7, 8

This beautiful cranidium is unique. The glabella has the usual shape and proportions and three pairs of shallow furrows are traceable. The occipital furrow is deep and wide and expands forward in the middle nearly to the backward-directed first pair of glabellar furrows. The occipital ring bears a small tubercle. The fixigenes are about three-fourths as wide as the glabella at the forward end of the

eye and are gently convex horizontally. Longitudinally they are rather convex to match the curvature of the whole cranidium. Eye lines prominent. Eyes small. The brim is of normal width. The preglabellar area is slightly wider than the rim. The rim is wide and thick in the middle, narrowing gradually toward the anterior angles. However, as the anterior angles are approached the narrowing is much more abrupt, giving rise to a rather peculiar depression in the anterior furrow. The surface, except the bottoms of the furrows, is covered by two sets of granules. A small set somewhat uneven in size is numerous and is overlain by a series of larger granules scattered irregularly over the entire cranidium. In addition, the preglabellar area has vertical anastomosing lines.

Locality 54s.

*Holotype*.—U.S.N.M. No. 98551.

#### KOCHINA WASATCHENSIS, n. sp.

Plate 12, figs. 12-14

This species is represented by a number of cranidia none of which are altogether complete. The glabella has the usual shape and size and is slightly keeled. The fixigenes are wide at the forward end of the eye, equaling the full width of the glabella at that point. Eye lines are clearly defined. Eyes small and situated well behind the midpoint of the cranidium. In cross section the fixigenes are gently convex except at the anterior angles, which are considerably depressed. Longitudinally the curvature is also slight. The brim is wide and concave and has the usual rim, which is much more thickened on some specimens than on others, a feature due to the degree of impression of the doublure. Surface nearly smooth except for vertical anastomosing lines on the preglabellar area.

Locality 54s.

*Holotype and paratype*.—U.S.N.M. Nos. 98552a, b.

#### KOCHINA? ELONGATA, n. sp.

Plate 12, figs. 15, 16

A single cranidium in the oolitic rock from the Brigham locality lies next to a specimen of *Winnanella maladensis*.

The cranidium is not fully typical of *Kochina* because of its narrowness and the proportionately great width of the glabella. In some respects it appears to be closer to *Inglefieldia*. However, the brim structure and eye size and position refer it to the genus rather

than to any other. The glabella is not very well differentiated in front; in fact, viewed in cross light it merges completely with the preglabellar area. By the light in a longitudinal direction a shallow dorsal furrow may be seen. The eyes are situated far back, almost touching the occipital furrow. The brim is wide and gently concave and has a wide rim faintly indicated chiefly by a change of curvature. This brim contracts only slightly toward the anterior angles, a feature that makes the generic reference doubtful. The surface appears to be smooth.

Locality 20x.

*Holotype*.—U.S.N.M. No. 98553.

**KOCHINA? LIBERTYENSIS, n. sp.**

Plate 12, fig. 6

A single cranidium in reddish-brown shale represents this species. It is closely associated with a large specimen of *Hyolithes* and fragments of other trilobites. It may not belong to the *Ptarmigania* fauna but is included because it occurs with material that evidently does belong to the fauna.

This is a narrow form with a rather strongly tapering glabella, which occupies over two-thirds of the cranidial length. The occipital furrow is clearly impressed, but glabellar furrows are lacking, and there is a slight keel. The brim is simple, swollen in the middle, and depressed at the anterior angles. The anterior furrow swings back from the anterior angles to the anterior dorsal furrow; consequently the rim widens in the middle to occupy the entire brim width. The eyes are of moderate size and situated about the midpoint of the cranidium. They are elevated as the fixigenes rise rather abruptly from the dorsal furrow and the eye lobes themselves are prominent. The fixigenes at the eyes have about half the glabellar width.

Locality 59f.

*Holotype*.—U.S.N.M. No. 98554.

**INGLEFIELDIA Poulsen, 1927**

**INGLEFIELDIA IDAHOENSIS, n. sp.**

Plate 12, fig. 9

*Inglefieldia* is distinguished from *Kochiella* only by its relative narrowness. For this reason this species is put into *Inglefieldia*. Its features are much like the species of *Kochiella* here described except that the width across the cranidium at the anterior end of the eye is much reduced by contraction of the fixigenes.

*I. idahoensis* is based on a single small cranidium. The glabella tapers to a truncated front. Weak glabellar furrows extend directly across the glabella. The fixigenes are nearly the same width throughout, equaling about two-thirds the greatest glabellar width. The eyes are fairly large, situated somewhat behind the midpoint of the glabella. Eye lines weak. Brim wide, with thickened rim slightly wider than preglabellar area. Facial suture does not diverge much anterior to the eye.

Locality 59f.

*Holotype*.—U.S.N.M. No. 98555.

**KOCHIELLA** Poulsen, 1927

**KOCHIELLA ARENOSA**, n. sp.

Plate 11, figs. 5-9

This species is evidently fairly abundant, but because it occurs in quartzite only fragments can be obtained. A nearly complete but badly weathered cranidium is in hand. The fragments illustrated are better preserved and show essential features. Libragenes are fairly common, and one pygidium definitely places the species in its genus.

The glabella is little more than half the length of the head and tapers forward. At its anterior end the dorsal furrow is not clearly impressed, so that the glabella joins the brim, and to do so the anterior angles of the glabella flair somewhat. Brim wide, first convex and then concave. Anterior margin is nearly straight and slightly indented in the middle. The fixigenes at their narrowest point are about as wide as the glabella. The eyes evidently are rather small, situated about the midpoint of the cranidium. Three pairs of glabellar furrows are indicated by fairly sharp depressions, next to the dorsal furrow. Eye lines present. The libragene is of normal form, very simple with a broad concave margin which extends into a long genal spine. The pygidium is of normal composition with a broad axis on which two rings may be seen. The dorsal furrow is shallow and two pleura are differentiated on the lobes. The axis does not stand above the pleural lobes very much, but the lobes are highly convex. The pleural lobes have a wide flaring border, at the rear of which is a deep notch. The pleural lobes are very convex and the pygidium slopes rapidly downward from the rear of the axis.

Locality 59c.

*Holotype and paratypes*.—U.S.N.M. Nos. 98556a-d.



**KOCHIELLA MANSFIELDI, n. sp.**

Plate 11, figs. 10-14

This species is abundant in the small amount of material collected from this locality. It is associated with *Dolichometopsis* and *Poulsenia*, as well as other genera.

The glabella is little more than half the length of the cranium and tapers considerably to a slightly rounded front. The dorsal furrow is definitely defined on the sides but becomes rather shallow in front of the glabella. Three pairs of shallow glabellar furrows may be noted. The fixigenes at the anterior end of the eye are nearly as wide as the glabella at that point, and they expand from the rear end of the eye forward owing both to the contraction of the glabella and to the slight divergence of the anterior facial suture. The eyes are of moderate size and situated rather far to the rear. Eye line prominent. Brim wide, nearly straight in front. On the whole it is concave, and when the doublure is impressed to show on the upper surface a wide brim is indicated. The associated pygidium is nearly quadrangular in outline with rounded anterior angles and slightly contracted lateral margins. The anterior half of the first segment forms a raised rim extending from the axis around the circular anterior angles and then backward into spines, which possibly are long. The axis is broad and has three axial rings, besides the terminal segment. It is only gently arched above the pleural lobes. The pleural lobes are nearly flat but slope down to the margin, and on them three pleura are delimited by the pleural furrows. Surface of cranium covered by scattered large granules, overlying a small crowded set. In the pygidium only the small granulations are present, but irregular lines occur on the outer edges.

Locality 19s.

*Holotype and paratypes*.—U.S.N.M. Nos. 98557a-d.

**KOCHASPIS Resser, 1935****KOCHASPIS MALADENSIS, n. sp.**

Plate 13, figs. 9-12

Three pygidia, but no cranium, were found at this locality. These pygidia constitute a typically developed species of *Kochaspis*. It is possible that the cranium is confused with the abundantly represented *Poulsenia granulosa*.

The pygidium is characterized by a prominent axis, which stands entirely above the pleural platforms. The axis is nearly semicircular in cross section and occupies nearly the full length of the pygidium.

terminating very abruptly in the rear. The pleural platforms are moderately convex, dropping off to the flattened border, which has a horizontal position. Both the pleural furrows and grooves remain, but the most conspicuous feature is the elevated rib formed by the anterior half of each pleuron. The border extends into long, stout, flat spines at the posterior angles.

Locality 54s.

*Holotype and paratype*.—U.S.N.M. Nos. 98558a, b.

#### KOCHASPIS DISPAR, n. sp.

Plate 13, figs. 1-4, 13-15

At first these cranidia and pygidia were regarded as separate species, but it was decided to refer the cranidia to the species based on the pygidium. Since examples of *Dolichomctopsis* occur on small pieces of rock with this species, it no doubt is a member of the *Ptarmigania* fauna.

The glabella is stout and tapers considerably to a rounded front. The dorsal furrow is deep. Three pairs of recurved glabellar furrows appear strongly in proper light. A slight keel is apparent on some specimens. The fixigenae are convex rising from the dorsal furrow and then curving down slightly to the eyes, which are rather prominent. The rim is almost equally divided between the slightly convex preglabellar area and the thickened rim. Longitudinally the cranidium is convex, with the greatest curvature in the rear and the whole forward half of the head sloping down rather sharply but without much curvature. Eye lines heavy. Surface slightly granulose; brim vertically striated with faint irregular lines.

The pygidium is much like that of *Vauvemella*, except that it is larger and that fusion has not completely eliminated the pleural markings.

The axis is stout and stands above the pleural platforms. Three axial furrows and the terminal segment are clearly defined. The axis has very steep slopes at the sides but the curvature is somewhat flattened on top. It terminates abruptly, but there is a slope to the rear margin. Fusion has reduced the pleural grooves to very shallow furrows, but the pleural furrows are more clearly defined. As in *K. maladensis* the anterior rib of each pleuron is elevated. The tail is wide, and hence the slightly thickened rim extends into spines which are set wide apart, more in the manner of *Vauvemella* than of *Kochaspis*. These spines are short.

Locality 59e.

*Holotype and paratypes*.—U.S.N.M. Nos. 98559a-d.

Family Undetermined

**POULSENIA** Resser, 1936

**POULSENIA GRANOSA**, n. sp.

Plate 13, figs. 19-30

This is a very prolific species, represented by many cranidia, a number of pygidia, and one complete specimen that permits unquestioned assignment of the pygidium.

The glabella tapers considerably to a rounded front and is strongly marked by three pairs of recurved glabellar furrows. The dorsal furrow is deep, in front joining the equally deep anterior furrow. The fixigenes are rather convex, sharply bent down to the eyes, and crossed by strong eye lines. Longitudinally they also are curved to meet the sharply depressed anterior angles and posterolateral limbs. Brim consists of a narrow preglabellar area, which is almost entirely occupied by the anterior furrow in the middle and a wider rim. The rim is thickened, and in the middle it expands backward.

The thorax apparently has 23 simple segments.

The pygidium is short and very wide, and when unexfoliated it is nearly smooth. A wide tapering axis extends nearly to the rear margin. When exfoliated it shows three axial rings, the terminal segment, and about three pleura. On the test only one ring and one pleuron usually are defined.

Surface, except on pygidium, very granulose.

Locality 54s.

*Holotype and paratypes*.—U.S.N.M. Nos. 98560a-g.

**POULSENIA OCCIDENS**, n. sp.

Plate 2, fig. 15

A single small cranidium differs from *P. granosa* in having a smooth test. It is nearly completely exfoliated, this feature causing the dorsal and glabellar furrows to be deeper than they would appear on the outer surface. The glabella is rather slender, tapering forward and rounded in front. There are three pairs of deep glabellar furrows. The fixigenes average wider than the glabella and are also convex in cross section. The brim width is about one-third the length of the glabella plus occipital ring. A deep anterior furrow clearly defines a thickened rim which is wider than the preglabellar area.

Locality 54s.

*Holotype*.—U.S.N.M. No. 9856.

**POULSENIA BEARENSIS**, n. sp.

Plate 13, figs. 5-8

Possibly this cranidium should have been referred to *Kochaspis*. Abundance of granulation, however, and the relief created by deep furrows weigh more heavily in favor of *Poulsenia*. None of the specimens is perfect, but the major features are well shown.

The rather long glabella tapers to a rounded front. Dorsal furrow deep. Three pairs of recurved glabellar furrows are deeply impressed. Brim divided into a slightly convex preglabellar area and a somewhat narrower thickened rim. Longitudinally the head is very convex. The fixigenes, which average nearly as wide as the glabella, rise from the dorsal furrow and then flatten out to the prominent eye. Eye lines heavy. Surface very granulose, with added vertical striations on preglabellar area.

Locality 19s.

*Holotype and paratype*.—U.S.N.M. Nos. 98562a, b.**EHMANIELLA** Resser, 1937**EHMANIELLA MALADENSIS**, n. sp.

Plate 12, figs. 17-23

The cranidia here described are not easily distinguished from the several associated species of *Kochina*. *Ehmaniella* seems the best generic reference for the species.

The slightly tapered glabella is rather slender and has a nearly circular outline in front. Three pairs of glabellar furrows are visible in proper light, and some specimens show a keel. The glabella does not rise much above the dorsal furrow. Longitudinally the glabella has little convexity except in the front lobe. The fixigenes are wider than the glabella and only gently convex. Posterolateral limbs are stout. The brim consists of a large preglabellar area and a thickened rim. There is a tendency to form a boss in the preglabellar area. Some exfoliated specimens show scattered granules. Both the specimens with and without the test have the preglabellar area and the fixigenes anterior to the eye lines strongly marked with vertical anastomosing lines.

Locality 54s.

*Holotype and paratypes*.—U.S.N.M. Nos. 98563a-e.**PACHYASPIS**, n. gen.

A very common species represents the median trilobite form in the collections from Two Mile Canyon. Comparison with described

genera representing this sort of trilobite shows that here is another genus that formerly would simply have been called *Ptychoparia*. It resembles several genera, such as *Elrathia*, *Ehmaniella*, *Clappaspis*, and many others. Its primary distinguishing feature, so far as general appearance goes, is its plumpness, brought about by convexity in both directions. When flattened down by photography, *Pachyaspis* appears most like *Ehmaniella*, with which I do not think it is related.

The glabella tapers slowly forward to a rounded front outline. The dorsal furrow is clearly defined, but not deep. In side light the glabella appears nearly smooth except for a slight keel, but in sharp longitudinal light four pairs of furrows become visible. The rear pair is recurved and very wide and seems to branch. The remaining pairs run about straight across the glabella. A slightly irregular occipital furrow, which is stronger than the dorsal furrow, separates a ring of nearly equal width throughout. This ring carries a small nuchal spine.

The brim consists of a slightly convex preglabellar area, which slopes down from the dorsal furrow. A clear but shallow anterior furrow separates a nearly flat, slightly upturned rim, which is a little more than half as wide as the preglabellar area.

The fixigenes average about half the glabellar width. They are convex to almost the same degree as the glabella. Forward of the eye the fixigene widens by the slight divergence of the facial suture. Behind the eye normal posterolateral limbs are formed.

The eyes are small. They are situated at about the midpoint of the cranidium. Eye lines of ordinary strength extend back to the eyes beginning near the anterior end of the glabella.

In spite of the abundance of specimens the librigenae has not been determined. Neither is the pygidium known. No doubt it is small and inconspicuous and therefore may be confused with something else.

*Name.*—πῦξις = plump; ἀσπίς = shield.

*Genotype.*—*P. typicalis*, new species.

#### PACHYASPIS TYPICALIS, n. sp.

Plate 11, figs. 15-20; plate 12, figs. 1-3

The generic diagnosis and illustrations adequately present specific characteristics.

Locality 54s.

*Holotype and paratypes.*—U.S.N.M. Nos. 98564a-f.

**TAXIOURA, n. gen.**

A very abundant trilobite with a large tail forms a conspicuous element of the fauna. Its description has been delayed by its reference to *Ogygopsis*.

The cranium is characterized by clear definitions of the usual parts, all, however, developed on a simple pattern. The glabella is large, rectangular in shape except for rounding at the anterior corner, and occupying nearly the full length of the cranium. Glabellar furrows are very faint. Brim narrow, concave, and without a rim, except as differentiated by an upturning of the outer margin. Eye lines conspicuous. Fixigenes roughly the same width throughout from the anterior angle to the rear end of the eye. Posterolateral limbs of normal size and shape. Eyes of moderate size and situated about the midpoint of the cranium. Libragene of normal composition, evidently sloping down rather sharply from the eye lobe and with a well-demarcated border. The moderately long genal spines have a peculiar shape. The posterolateral limbs do not reach the genal angle but a flange equal to their width is formed as a connection by extension from the ocular platform. Surface covered with fine anastomosing lines on the ocular platform, changing to striations on the border.

Pygidium approximately semicircular. Axis narrow and occupying the full length of the pygidium, differentiated into about 10 rings and the terminal segment, which extends into a postaxial ridge. Pleural lobes large, well fused. Pleural furrows conspicuous and straight. Pleural grooves obsolete. Margin smooth except for a small recurved spine at the anterior corner and an indentation at the rear of the axis.

Hypostoma not located.

*Name.*—*ταῖς* = regularity; *οὔρα* = tail.

**TAXIOURA TYPICALIS, n. sp.**

Plate 14, figs. 6-14

This species is very abundant, the separated shields often forming almost the entire rock. The glabella is long and simple, tapering slightly both forward and rearward and is slightly protuberant in front. Glabellar furrows only faintly seen in direct longitudinal light. In cross section the glabella rises with a flat curve only moderately above the dorsal furrow and in longitudinal section has a

moderate even curvature throughout. In other words, the cranidium is not highly convex. Brim narrow, consisting of a simple concave extension on which a rim is outlined by a slight increase in curvature of the brim. Fixigenes average a little less than one-third the width of the glabella. Eye ridges heavy. Eyes nearly one-third the length of the cranidium and set at a moderate angle to the median line. Neck furrow shallow but clearly defined. Neck ring expanded, possibly bearing a small nuchal spine.

The pygidium has the characteristics already given with the generic description. The pleural ribs are rounded and fusion has completely eliminated the pleural grooves.

Surface covered by fine anastomosing lines.

Locality 54s.

*Holotype and paratype*.—U.S.N.M. Nos. 98565a-g.

#### TAXIOURA MAGNA, n. sp.

Plate 14, figs. 1-5

This species is represented by the nearly complete holotype cranidium and a number of fragmentary examples. A librigena and a single pygidium has been assigned to the species.

This species is characterized by a very long glabella with nearly parallel sides except for constriction anterior to the eye lines. Anterior margin rounded. Three pairs of shallow, irregular glabellar furrows are clearly indicated. The occipital furrow is fairly deep, particularly on the sides, and the occipital ring is expanded, terminating in a small blunt spine. Brim very narrow consisting essentially of an upturned rim. Fixigenes average nearly half the width of the glabella. Eye lines very heavy. Eye less than one-fourth the length of the cranidium and set at only a small angle to the course of the dorsal furrow. The librigena is marked by a steep slope from the eye to the horizontal, slightly thickened border. Genal spine heavy and possibly long.

A rather large pygidium is assigned to the species. It is like that of *T. typicalis* in shape and relative size as well as in the characteristics of the margin. It is particularly characterized by the flatness of the upper surface of the ribs and the fact that fusion has not completely eliminated the pleural grooves. Surface rather coarsely marked by irregular lines and granules.

Locality 54s.

*Holotype and paratypes*.—U.S.N.M. Nos. 98566a-c.

## REFERENCES

DEISS, CHARLES.

1938. Cambrian formations and sections in part of Cordilleran Trough. Bull. Geol. Soc. Amer., vol. 49, pp. 1067-1168.

MANSFIELD, G. R.

1929. Geography, geology and mineral resources of the Portneuf quadrangle, Idaho. U. S. Geol. Surv. Bull. 803.

RESSER, C. E.

1939. The Spence shale and its fauna. Smithsonian Misc. Coll., vol. 97, No. 12.

RICHARDSON, G. B.

1913. The Paleozoic section in northern Utah. Amer. Journ. Sci., vol. 36, pp. 406-416.

WALCOTT, C. D.

1908. Nomenclature of some Cambrian Cordilleran formations. Smithsonian Misc. Coll., vol. 53, No. 1.

1908. Cambrian sections of the Cordilleran area. Smithsonian Misc. Coll., vol. 53, No. 5.

## EXPLANATION OF PLATES

All figures are natural size unless otherwise marked. Localities are given only when other than 54s.

## PLATE I

	PAGE
<i>Micromitra haydeni</i> Walcott.....	20
1. Ventral valve (Walcott fig. B) (× 4).	
2. Dorsal valve (Walcott fig. C) (× 4).	
3. Holotype dorsal valve (Walcott fig. A) (× 5).	
<i>Paterina hirta</i> , new species.....	20
4. Dorsal valve (× 4).	
5. Ventral valve (Walcott fig. 2a) (× 6).	
6. Smaller dorsal valve (× 3).	
7. Ventral valve (× 5).	
<i>Iphidella maladensis</i> Walcott.....	20
8. Ventral valve (Walcott fig. 2) (× 4).	
9. Lectotype dorsal valve (Walcott fig. 2c) (× 3).	
10. Another dorsal valve (Walcott fig. 2d) (× 5).	
<i>Acrotreta sulcata</i> Walcott.....	21
11. Exterior ventral valve (× 9).	
12. Dorsal valve (× 6).	
13. Ventral valve (× 6).	
14. Holotype ventral valve (Walcott fig. 5) (× 9).	
<i>Acrotreta eucharis</i> , new species.....	22
15. Dorsal valve (× 7).	
16. Dorsal valve (× 5).	
17. Exterior ventral valve (× 6).	
18. Ventral valve (× 8).	



	PAGE
<i>Acrothele artemis</i> Walcott.....	21
19. Exterior dorsal valve ( $\times 2.5$ ).	
20. Ventral valve ( $\times 3$ ).	
21. Dorsal valve ( $\times 2$ ).	
22. Holotype dorsal valve (Walcott fig. 54) ( $\times 2$ ).	
<i>Acrothele parilis</i> , new species.....	21
23. Exterior of ventral valve ( $\times 3$ ).	
24. Interior of ventral valve (Walcott fig. 3e) ( $\times 3$ ).	
25. Dorsal valve (Walcott fig. 1g) ( $\times 3$ ).	
<i>Acrothyra minor</i> Walcott.....	22
26. Holotype ventral valve (Walcott fig. 4) ( $\times 6$ ).	
27. Ventral valve (Walcott text fig. 59) ( $\times 5$ ).	
28. Interior ventral valve (Walcott fig. 4a) ( $\times 6$ ).	
29. Ventral valve (Walcott fig. 4b) ( $\times 7$ ).	
<i>Lingulella eucharis</i> Resser.....	22
30. Dorsal valve ( $\times 5$ ).	
31. Ventral valve ( $\times 5$ ).	
32. Dorsal valve ( $\times 5$ ).	
<i>Wimanellelta maladensis</i> , new species.....	23
33, 34. Ventral valves ( $\times 1.5$ ).	
35, 36. Dorsal valves ( $\times 1.5$ ).	
37. Ventral valve ( $\times 3$ ).	
<i>Helcionella arguta</i> , new species.....	23
38-40. Specimens in various attitudes ( $\times 2.5$ ).	
41. Another example with <i>Dolichometopsis natalis</i> ( $\times 2.5$ ).	
<i>Helcionella burlingi</i> , new species.....	24
42-44. Several examples ( $\times 3$ ).	
Locality 59f, 5 miles southwest of Liberty, Bear River Range, Idaho.	
<i>Helcionella acqua</i> , new species.....	24
45-47. Three views of holotype ( $\times 2.5$ ).	

## PLATE 2

<i>Hyolithes prolixus</i> , new species.....	24
1, 2. Two examples showing flat side ( $\times 1.5$ ).	
3. Cross section near apical end ( $\times 1.5$ ).	
<i>Pagetia maladensis</i> , new species.....	25
4. Pygidium, impression of cranidium, and examples of <i>Acrotreta sulcata</i> ( $\times 5$ ).	
5, right. Holotype cranidium and pygidium ( $\times 5$ ).	
<i>Pagetia clytia</i> Walcott.....	25
5, top and left. Cranidia of <i>P. clytia</i> ( $\times 5$ ). Note in partial cranidium below left center occipital spine and curvature of fixigenes to the eye.	
6. Pygidium of usual appearance ( $\times 5$ ).	
7. Cranidium with occipital spine ( $\times 5$ ).	
8. Pygidium in matrix to show axial spine ( $\times 5$ ).	
<i>Bathyriscus politus</i> , new species.....	30
9. Holotype pygidium ( $\times 5$ ).	

	PAGE
<i>Tonkinella idahoensis</i> , new species.....	45
10. Holotype pygidium ( $\times 4$ ).	
<i>Alokistocare cuchare</i> , new species.....	51
11, 12. Holotype cranidium ( $\times 1.5$ ).	
<i>Alokistocarella occidens</i> , new species.....	52
13, 14. Holotype cranidium ( $\times 2$ ).	
<i>Poulsenia occidens</i> , new species.....	59
15. Holotype cranidium ( $\times 4$ ).	
<i>Agnostus lautus</i> , new species.....	25
16. Cranidia and pygidium ( $\times 5$ ).	
17, 18. Other pygidia ( $\times 5$ ).	

## PLATE 3

<i>Oryctocephalites typicalis</i> , new species.....	45
1. Small cranidium ( $\times 4$ ).	
2. Holotype cranidium ( $\times 5$ ).	
3. A large cranidium ( $\times 5$ ).	
4-6. Pygidia ( $\times 4$ ).	
<i>Oryctocephalus maladensis</i> , new species.....	45
7. Only fragment of pygidium discovered ( $\times 1.5$ ).	
8. Well-preserved holotype cranidium ( $\times 4$ ).	
9. Large cranidium ( $\times 4$ ).	
<i>Prozacanthoides alatus</i> , new species.....	26
10. Holotype cranidium ( $\times 2.5$ ).	
11. Large pygidium ( $\times 4$ ).	
12. Small pygidium ( $\times 5$ ).	
<i>Prozacanthoides libertyensis</i> , new species.....	27
13. Cranidium doubtfully referred to the species ( $\times 3$ ).	
14. Cranidium ( $\times 2.5$ ).	
15. Squeeze of holotype pygidium ( $\times 2.5$ ).	
<i>Prozacanthoides decorosus</i> , new species.....	27
16. Holotype cranidium ( $\times 2$ ).	
17. Pygidium ( $\times 2$ ).	
18. Hypostoma and cranidium ( $\times 2$ ).	
<i>Prozacanthoides exilis</i> , new species.....	28
19. Pygidium ( $\times 2$ ).	
20. Holotype cranidium ( $\times 3$ ).	
<i>Prozacanthoides acquus</i> , new species.....	28
21. Holotype cranidium ( $\times 2$ ).	
22. Cranidium ( $\times 2.5$ ).	
23. Pygidium ( $\times 4$ ).	
<i>Prozacanthoides optatus</i> , new species.....	29
24. Impression of holotype showing intragenal spine ( $\times 3$ ).	
25, 26. Holotype cephalon with thoracic segments ( $\times 3$ ).	
27. Cranidium ( $\times 4$ ).	
28. Cranidium ( $\times 2.5$ ).	
29. Pygidium ( $\times 4$ ).	
30. Cranidium and hypostoma ( $\times 3$ ).	

	PAGE
<i>Dolichometopsis lepida</i> , new species.....	31
31. Libragene ( $\times 1.5$ ).	
32, 33. Holotype cranidium ( $\times 1.5$ ).	
<i>Ptarmigania</i> , species undetermined.....	42
34. Small cranidium ( $\times 6$ ).	
<i>Ptarmigania aurita</i> , new species.....	37
35, 36. Holotype cranidium ( $\times 2.5$ ).	
<i>Dolichometopsis stella</i> , new species.....	32
37. Holotype pygidium ( $\times 1.5$ ).	

## PLATE 4

<i>Ptarmigania exigua</i> , new species.....	38
1, 2. Holotype cranidium ( $\times 2$ ).	
3, 4. Cranidium with libragene ( $\times 2$ ).	
5. Small cranidium and pygidium ( $\times 6$ ).	
6, 7. Cranidium ( $\times 2$ ).	
8, 9. Pygidium ( $\times 4$ ).	
10. Libragene ( $\times 2$ ).	
<i>Dolichometopsis media</i> , new species.....	32
11, 12. Holotype pygidium ( $\times 1.5$ ).	
<i>Ptarmigania natalis</i> , new species.....	39
13, 14. Small cranidium ( $\times 3.5$ ).	
15, 16. Holotype cranidium ( $\times 2.5$ ).	
17, 18. Libragenes ( $\times 3$ ).	
<i>Dolichometopsis alia</i> , new species.....	32
19, 20. Holotype cranidium ( $\times 3$ ).	
21. Cranidium doubtfully referred to species ( $\times 4$ ).	
<i>Dolichometopsis comis</i> , new species.....	33
22, 23. Pygidium ( $\times 1.5$ ).	
24. Holotype and incomplete cranidium ( $\times 1.5$ ).	
<i>Ptarmigania ornata</i> , new species.....	39
25, 26. Small cranidium ( $\times 3$ ).	
27. Cranidium ( $\times 2.5$ ).	
28, 29. Libragenes ( $\times 3$ ).	
30, 31. Holotype cranidium ( $\times 3$ ).	
32. Cranidium, and <i>Kootenia convoluta</i> ( $\times 2.5$ ).	

## PLATE 5

<i>Dolichometopsis poulsoni</i> , new species.....	33
1, 2. Holotype cranidium ( $\times 1.5$ ).	
3, 4. Pygidium ( $\times 1.5$ ).	
5, 6. Thorax and pygidium ( $\times 1.5$ ).	
Locality 59e.	
7, 8. Cranidium ( $\times 1.5$ ).	
9, 10. Pygidium ( $\times 1.5$ ).	
<i>Dolichometopsis propinqua</i> , new species.....	34
11, 12. Pygidium ( $\times 1.5$ ).	
13. Holotype cranidium at left; fragmentary pygidium at lower right; other pygidium <i>Kootenia</i> ( $\times 1.5$ ).	

## PLATE 6

	PAGE
<i>Dolichometopsis gregalis</i> , new species.....	34
1, 2. Holotype cranium ( $\times 1.5$ ).	
3, 4. Pygidium ( $\times 1.5$ ).	
Locality 59e.	
<i>Dolichometopsis communis</i> , new species.....	35
5, 6. Holotype cranium ( $\times 1.5$ ).	
7, 8. Pygidium ( $\times 1.5$ ).	
<i>Kochina venusta</i> , new species.....	53
9, 10. Holotype cranium ( $\times 3$ ).	
<i>Dolichometopsis mansfieldi</i> , new species.....	36
11, 12. Cranium ( $\times 1.5$ ).	
13, 14. Holotype cranium.	
15. Hypostoma ( $\times 2$ ).	
16. Cranium and pygidium. In association are a cranium and libragene of <i>Kochiella mansfieldi</i> , <i>Clavaspidella</i> , and <i>Poulsenia</i> .	
<i>Dolichometopsis potens</i> , new species.....	36
17, 18. Small cranium ( $\times 2.5$ ).	
19. Holotype cranium ( $\times 1.5$ ).	
20. Another small cranium ( $\times 1.5$ ).	
21, 22. Hypostoma.	
23. Partial pygidium, impression of cranium, and fragment of <i>Olcnoides</i> pygidium ( $\times 1.5$ ).	

## PLATE 7

<i>Ptarmigania agrestis</i> , new species.....	39
1, 2. Holotype cranium ( $\times 1.5$ ).	
<i>Ptarmigania altilis</i> , new species.....	40
3, 4. Holotype cranium ( $\times 1.5$ ).	
5. Libragene ( $\times 1.5$ ).	
<i>Dolichometopsis gravis</i> , new species.....	36
6, 7. Holotype cranium ( $\times 1.5$ ).	
8, 9. Smaller cranium.	
10, 11. Pygidium ( $\times 1.5$ ).	
<i>Ptarmigania sobrina</i> , new species.....	40
12, 13. Holotype cranium, pygidium, libragene, and other fragments ( $\times 1.5$ ).	
14, 15. Pygidium ( $\times 1.5$ ).	
<i>Ptarmigania germana</i> , new species.....	41
16. Cranium ( $\times 1.5$ ).	
17, 18. Holotype cranium ( $\times 1.5$ ).	
19, 20. Pygidium ( $\times 1.5$ ).	

## PLATE 8

<i>Ptarmigania dignata</i> , new species.....	41
1, 2. Large pygidium ( $\times 1.5$ ).	
3. Libragene ( $\times 1.5$ ).	
4, 5. Pygidium ( $\times 1.5$ ).	
6, 7. Holotype cranium ( $\times 1.5$ ).	

	PAGE
<i>Glossopleura arrecta</i> , new species.....	42
8. Holotype pygidium ( $\times 1$ ).	
9. Holotype pygidium ( $\times 1.5$ ).	
10. Less complete pygidium.	
Locality 55p.	
<i>Glossopleura prona</i> , new species.....	42
11, 12. Holotype pygidium ( $\times 1.5$ ).	
13, 14. Cranidium ( $\times 1.5$ ).	
Locality 55p.	
<i>Clavaspidella wasatchensis</i> , new species.....	43
15, 16. Pygidium ( $\times 1.5$ ).	
17, 18. Impressions of pygidia and librigenes ( $\times 1.5$ ).	
19, 20. Holotype cranidium ( $\times 1.5$ ).	
Locality 20x.	

## PLATE 9

<i>Clavaspidella excavata</i> , new species.....	43
1, 2. Hypostoma ( $\times 2$ ).	
3, 4. Holotype cranidium ( $\times 2$ ).	
5, 6. Pygidia, cranidium, and <i>Poulsenia</i> cranidium ( $\times 2$ ).	
Locality 59c.	
<i>Kootenia libertyensis</i> , new species.....	48
7. Cranidium ( $\times 4$ ).	
8. Holotype pygidium ( $\times 2.5$ ).	
9. Small pygidium ( $\times 4$ ).	
Locality 59c.	
<i>Kootenia venusta</i> , new species.....	48
10. Cranidium ( $\times 2$ ).	
11. Holotype pygidium ( $\times 1.5$ ).	
Locality 59c.	
<i>Kootenia pectenoides</i> , new species.....	50
12, 13. Holotype pygidium ( $\times 1.5$ ).	
Locality 59q.	
<i>Kootenia mendosa</i> , new species.....	49
14. Partial cranidium, compressed in shale ( $\times 1.5$ ).	
15, 16. Holotype pygidium ( $\times 1.5$ ).	
17, 18. Cranidium, with examples of <i>Wimaneella</i> and <i>Clavaspidella wasatchensis</i> ( $\times 1.5$ ).	
Locality 20x.	
<i>Kootenia germana</i> , new species.....	49
19. Squeeze of cranidium and pygidium ( $\times 1.5$ ).	
20. Holotype pygidium ( $\times 2$ ).	
21. Holotype pygidium ( $\times 1.5$ ).	
22. Hypostoma ( $\times 1.5$ ).	
23, 24. Cranidium ( $\times 1.5$ ).	
Locality 20x.	

## PLATE 10

	PAGE
<i>Kootenia convoluta</i> , new species.....	46
1-3. Enrolled holotypes ( $\times 1.5$ ).	
4-6. Excellent cranidium ( $\times 1.5$ ).	
7, 8. Exfoliated cranidium ( $\times 1.5$ ).	
9, 10. Exfoliated pygidium ( $\times 1.5$ ).	
11. Pygidium ( $\times 1.5$ ).	
<i>Kootenia maladensis</i> , new species.....	47
12, 13. Pygidium ( $\times 2$ ).	
14, 15. Holotype cranidium ( $\times 2.5$ ).	
<i>Kootenia granulosa</i> , new species.....	47
16. Small cranidium ( $\times 3$ ).	
17. Holotype cranidium ( $\times 2.5$ ).	
18. Small pygidium ( $\times 2.5$ ).	
19. Pygidium ( $\times 1.5$ ).	
20. Pygidium ( $\times 3$ ).	
<i>Kootenia nitida</i> , new species.....	47
21. Holotype cranidium ( $\times 3.5$ ).	
<i>Kootenia bearensis</i> , new species.....	50
22, 23. Holotype pygidium ( $\times 2$ ).	
Locality 19x.	
<i>Kootenia acicularis</i> , new species.....	49
24. Small cranidium ( $\times 6$ ).	
25, 26. Holotype pygidium ( $\times 1.5$ ).	
<i>Olenoides maladensis</i> , new species.....	46
27. Holotype pygidium ( $\times 1.5$ ).	
28. Pygidium ( $\times 1.5$ ).	

## PLATE 11

<i>Kootenia brevispina</i> , new species.....	50
1, 2. Large pygidium ( $\times 1.5$ ).	
3. Holotype pygidium ( $\times 1.5$ ).	
4. Holotype pygidium ( $\times 2.5$ ).	
<i>Kochiella arenosa</i> , new species.....	56
5, 6. Impressions of cranidia ( $\times 1.5$ ).	
7. Libragene ( $\times 1.5$ ).	
8, 9. Pygidium ( $\times 2$ ).	
Locality 59c.	
<i>Kochiella mansfieldi</i> , new species.....	57
10, 11. Large pygidium ( $\times 2$ ).	
12. Partial cranidium ( $\times 1.5$ ).	
13. Holotype cranidium, and impression of <i>Dolichometopsis</i> pygidium ( $\times 1.5$ ).	
14. Pygidium, with <i>Poulsenia</i> ( $\times 1.5$ ).	
Locality 10s.	
<i>Pachyaspis typicalis</i> , new species.....	61
15, 16. Small cranidium ( $\times 2$ ).	
17. Cranidium ( $\times 2$ ).	
18, 19. Holotype cranidium ( $\times 3$ ).	
20. Cranidia ( $\times 3$ ).	
(See also plate 12, figs. 1-3.)	

## PLATE 12

	PAGE
<i>Pachyaspis typicalis</i> , new species.....	61
1. Small cranium ( $\times 5$ ).	
2, 3. Exfoliated cranium ( $\times 2$ ).	
(See also plate 11, figs. 15-20.)	
<i>Alokistocare euzona</i> , new species.....	51
4, 5. Holotype cranium ( $\times 1.5$ ).	
Locality 59f.	
<i>Kochina? libertyensis</i> , new species.....	55
6. Holotype cranium ( $\times 2$ ).	
Locality 59f.	
<i>Kochina vestita</i> , new species.....	53
7, 8. Holotype cranium ( $\times 2$ ).	
<i>Inglefieldia idahocensis</i> , new species.....	55
9. Holotype cranium ( $\times 5$ ).	
Locality 59f.	
<i>Alokistocare globatum</i> , new species.....	52
10, 11. Holotype cranium ( $\times 2$ ).	
Locality 55p.	
<i>Kochina wasatchensis</i> , new species.....	54
12, 13. Holotype cranium ( $\times 1.5$ ).	
14. Cranium with cranidia of <i>Taxioura</i> and <i>Pachyaspis</i> ( $\times 1.5$ ).	
<i>Kochina? clongata</i> , new species.....	54
15, 16. Holotype cranium ( $\times 3$ ).	
Locality 20x.	
<i>Ehmaniella maladensis</i> , new species.....	60
17. Small cranium ( $\times 6$ ).	
18, 19. Cranium ( $\times 2$ ).	
20, 21. Holotype cranium ( $\times 3$ ).	
22. Another cranium ( $\times 3$ ).	
23. Partially exfoliated cranium, with <i>Taxioura typicalis</i> ( $\times 2$ ).	

## PLATE 13

<i>Kochaspis dispar</i> , new species.....	58
1, 2. Cranium ( $\times 2$ ).	
3, 4. Partially exfoliated cranium ( $\times 2$ ).	
(See also figs. 13-15.)	
Locality 59e.	
<i>Poulsenia bearensis</i> , new species.....	60
5, 6. Incomplete cranium ( $\times 1.5$ ).	
7, 8. Holotype cranium ( $\times 2$ ).	
Locality 19s.	
<i>Kochaspis maladensis</i> , new species.....	57
9, 10. Pygidium ( $\times 2.5$ ).	
11, 12. Holotype pygidium ( $\times 3$ ).	
<i>Kochaspis dispar</i> , new species.....	58
13, 14. Holotype pygidium ( $\times 2$ ).	
15. Pygidium ( $\times 2$ ).	
(See also figs. 1-4.)	
Locality 59e.	

	PAGE
<i>Poliella wasatchensis</i> , new species.....	30
16. Holotype ( $\times 1.5$ ).	
Locality 20x.	
<i>Alokistocarella brighamensis</i> , new species.....	53
17. Cranidium and thorax ( $\times 1.5$ ).	
18. Holotype ( $\times 1.5$ ).	
Localities 55e, 20x.	
<i>Poulsenia granosa</i> , new species.....	59
19. Pygidium ( $\times 4$ ).	
20. Small pygidium ( $\times 6$ ).	
21. Pygidium with test ( $\times 6$ ).	
22, 23. Exfoliated cranidium ( $\times 2$ ).	
24-27. Cranidia showing ornamentation ( $\times 1.5$ ).	
28-30. Holotype ( $\times 1.5$ ).	

## PLATE 14

<i>Taxioura magna</i> , new species.....	63
1, 2. Pygidium ( $\times 1.5$ ).	
3, 4. Holotype cranidium ( $\times 1.5$ ).	
5. Libragene ( $\times 1.5$ ).	
<i>Taxioura typicalis</i> , new species.....	62
6. Libragene.	
7-9. Cranidia ( $\times 1.5$ ).	
10. Holotype cranidium and pygidium ( $\times 1.5$ ).	
11, 12. Well-preserved pygidium ( $\times 1.5$ ).	
13. Weathered cranidia ( $\times 1.5$ ).	
14. Pygidia with <i>Acrothele artemis</i> ( $\times 1.5$ ).	



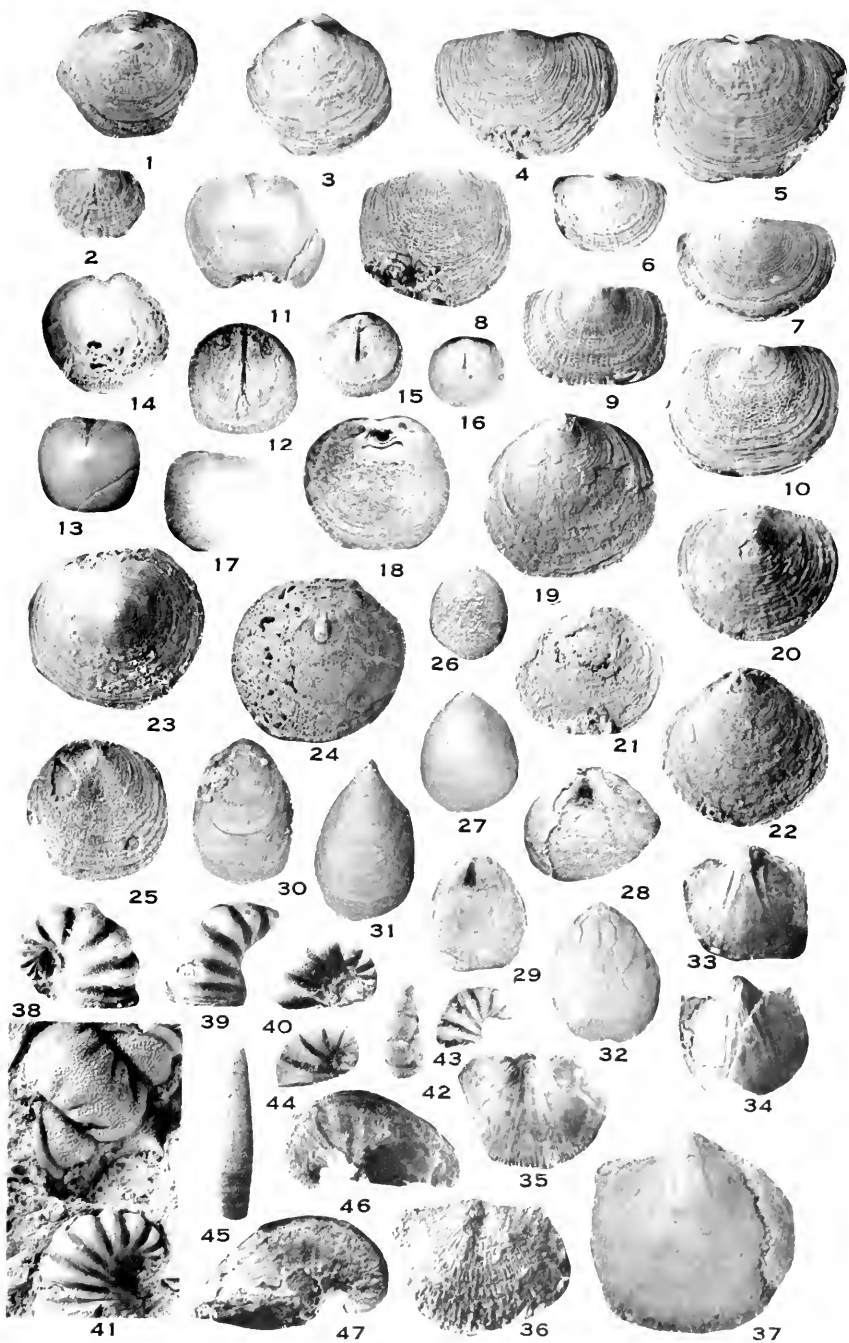

BRACHIOPODS AND GASTROPODS  
(See explanation of plates at end of text.)

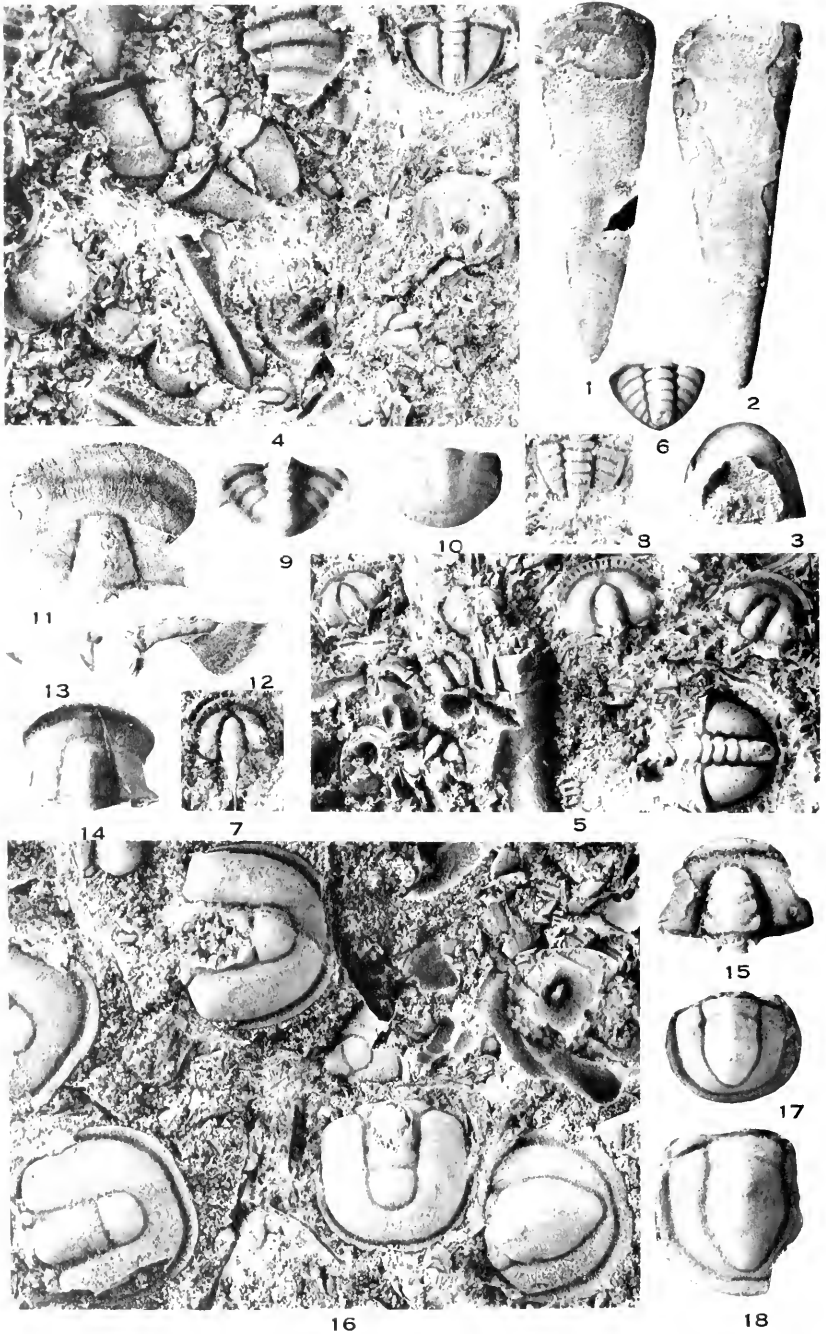

HYOLITHES AND TRILOBITES  
(See explanation of plates at end of text.)

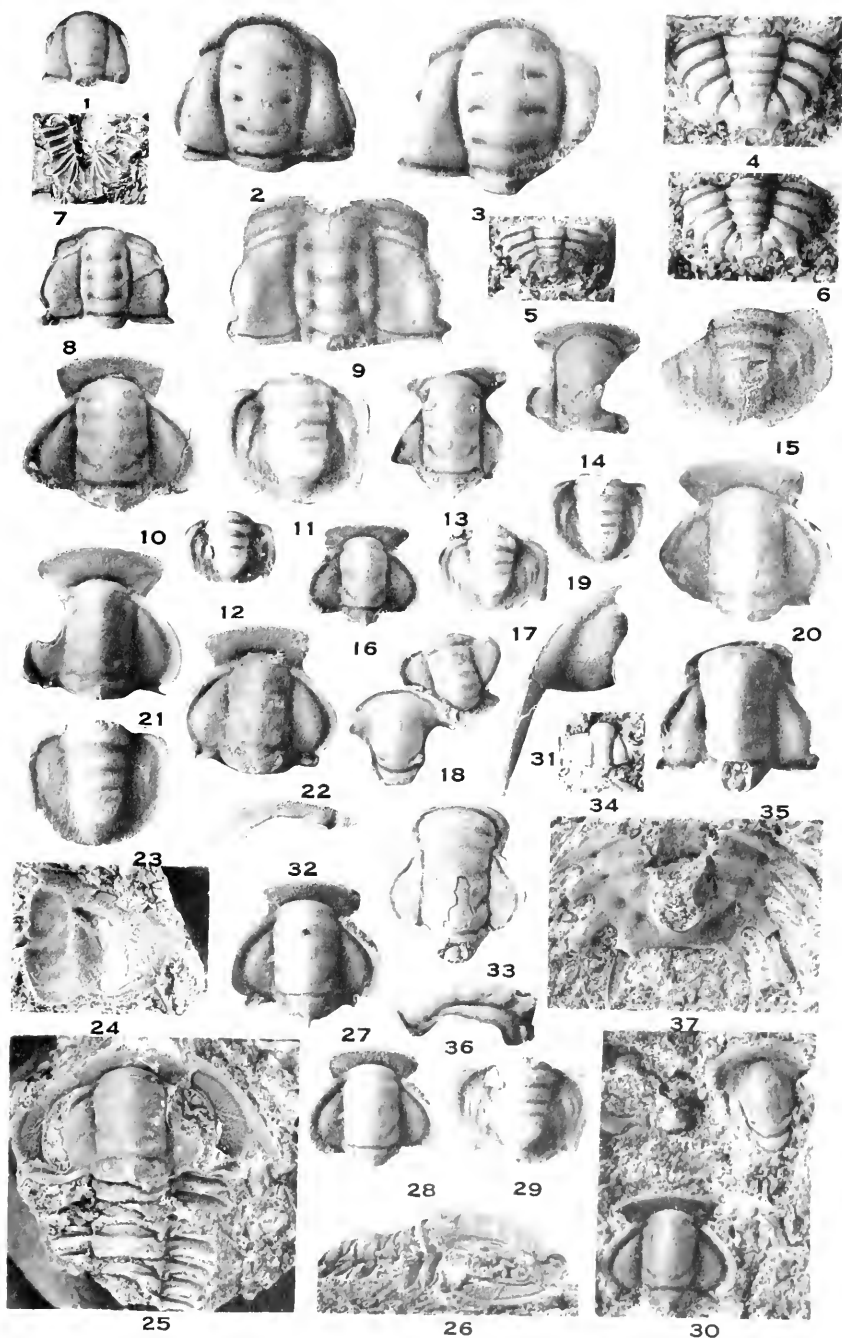

PROZACANTHOIDES AND OTHER TRILOBITES  
(See explanation of plates at end of text.)

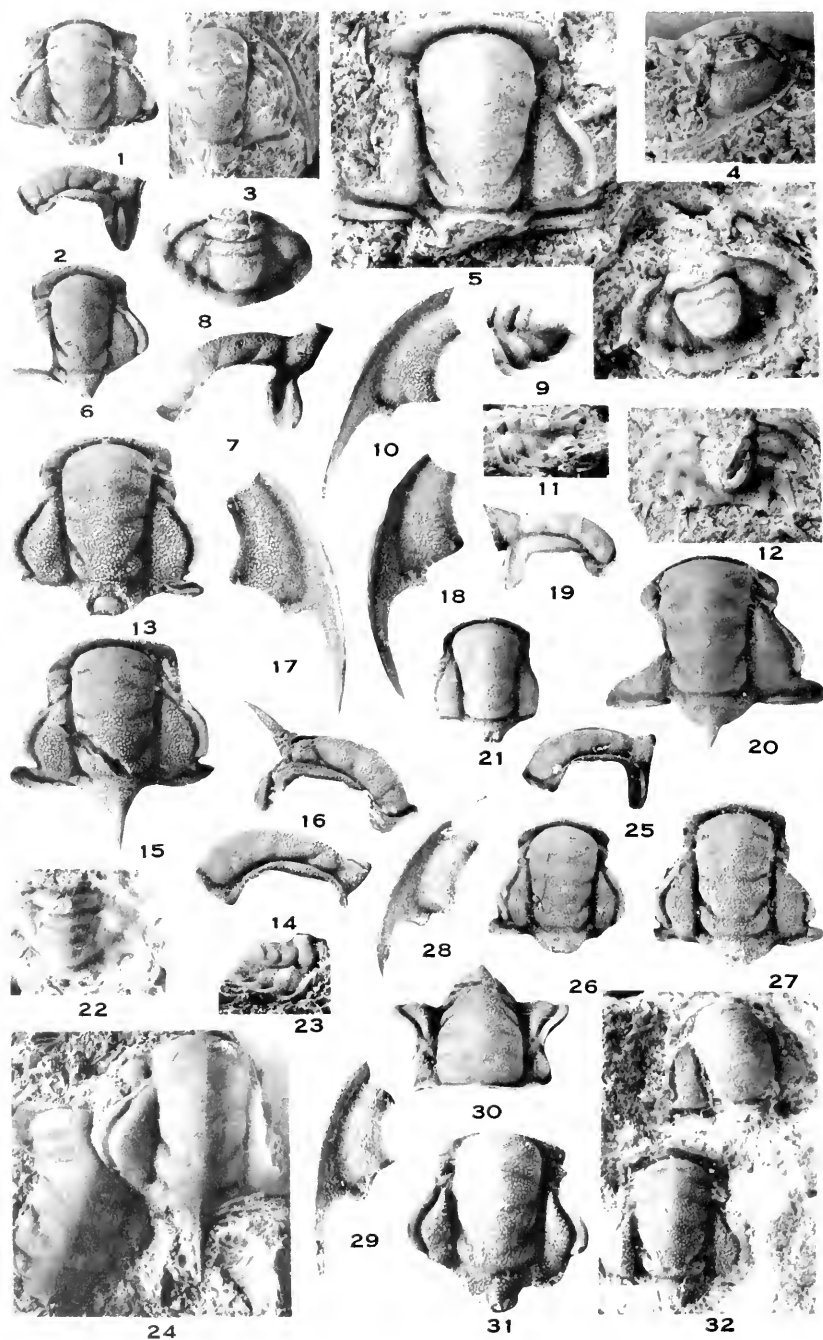

PTARMIGANIA AND DOLICHOMETOPSIS

(See explanation of plates at end of text.)

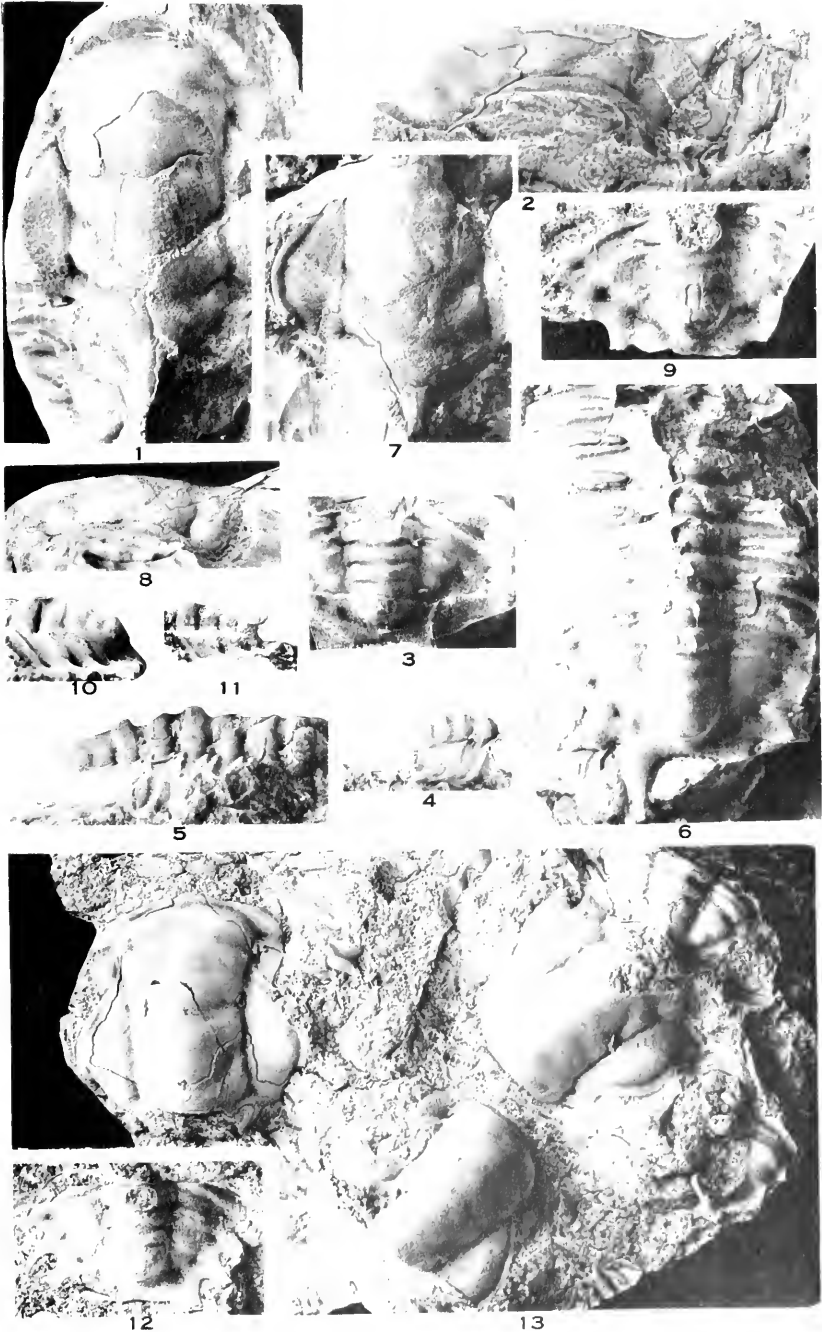

DOLICHOMETOPSIS

(See explanation of plates at end of text.)

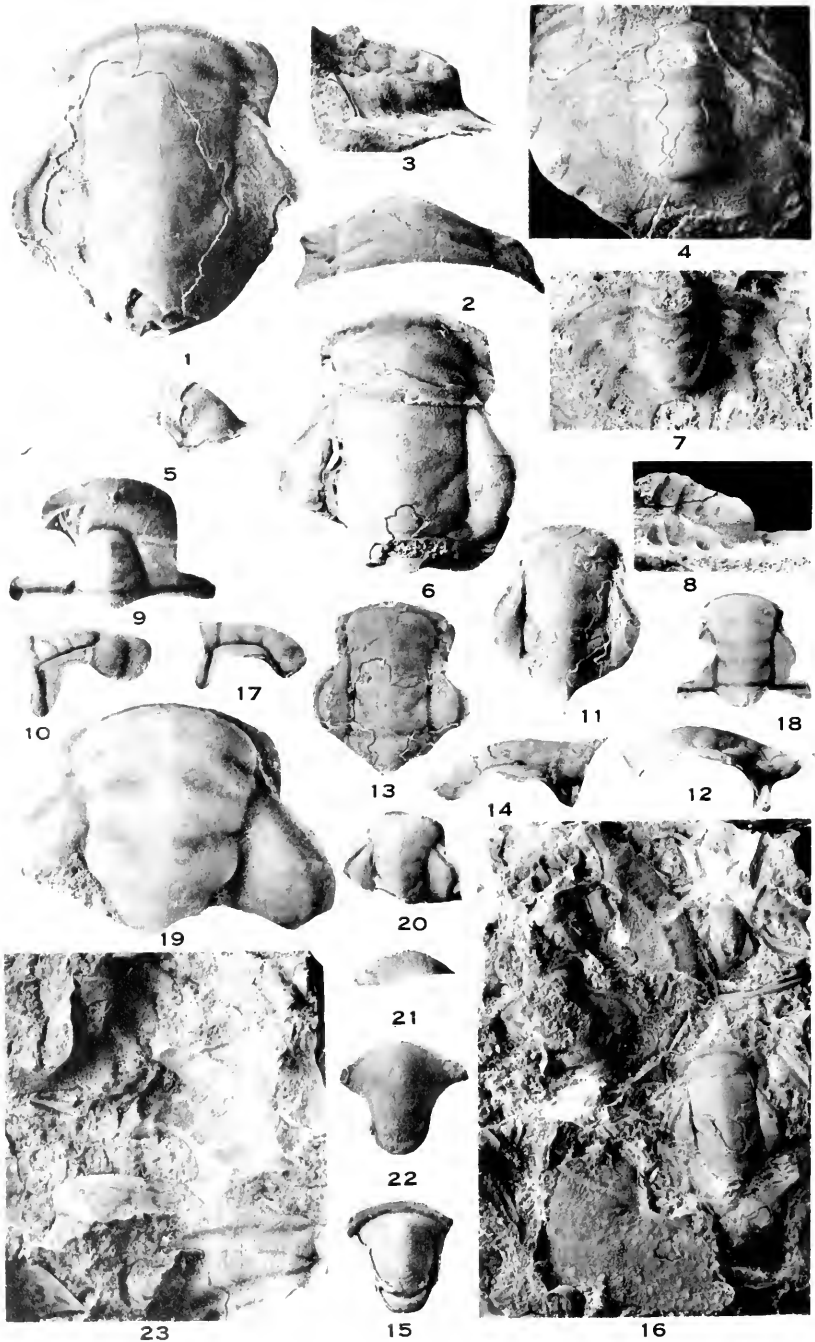

DOLICHOMETOPSIS AND KOCHINA  
(See explanation of plates at end of text.)

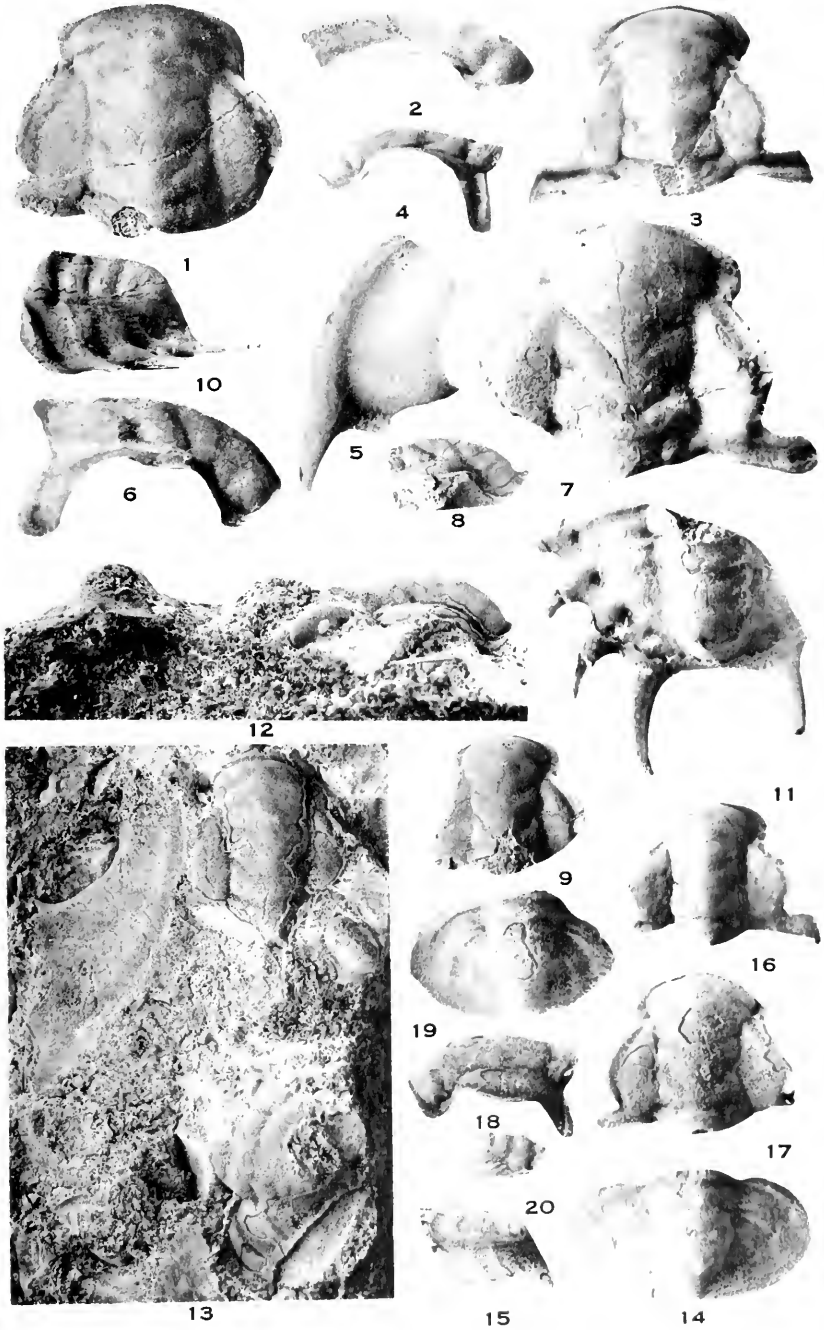

PTARMIGANIA AND DOLICHOMETOPSIS  
(See explanation of plates at end of text.)

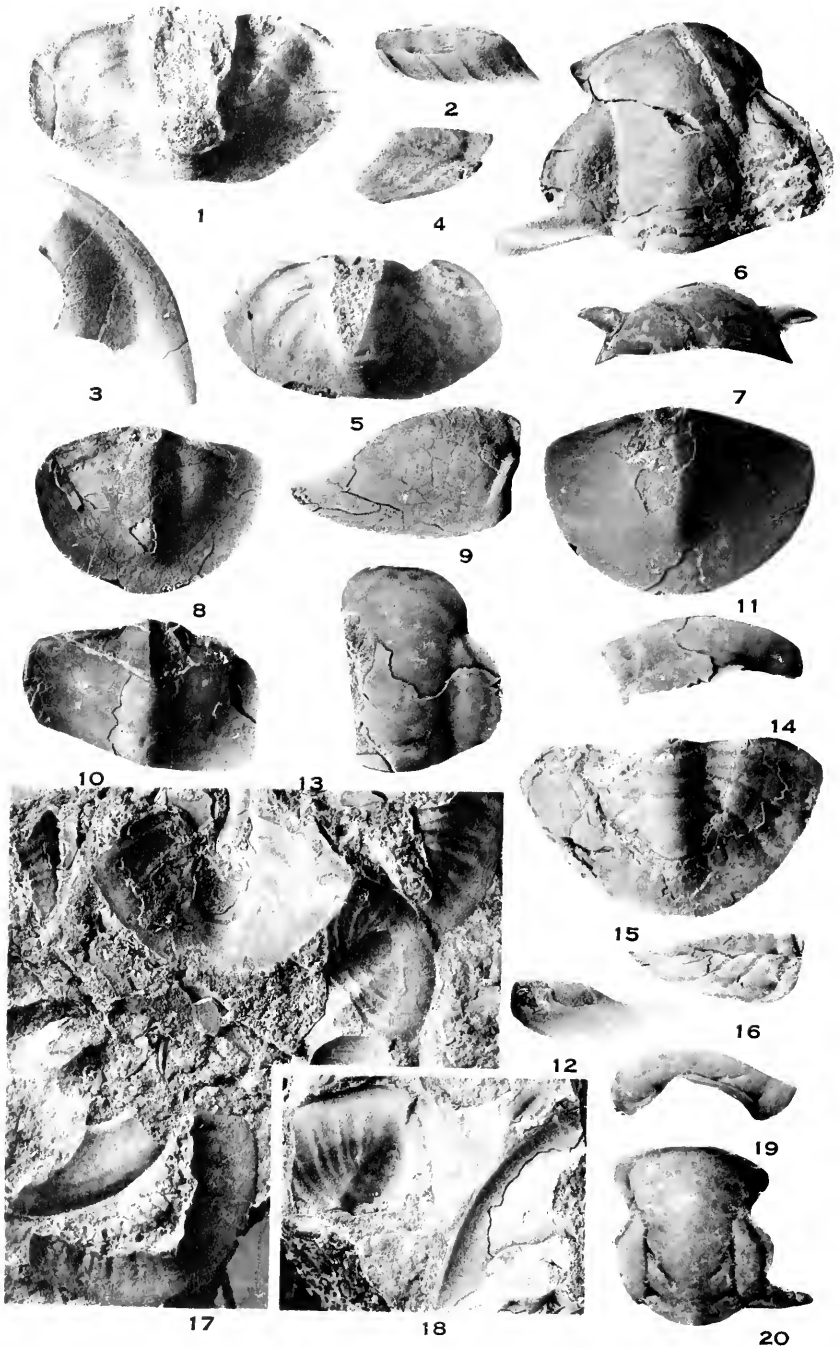

PTARMIGANIA, GLOSSOPLEURA, CLAVASPIDELLA  
(See explanation of plates at end of text.)



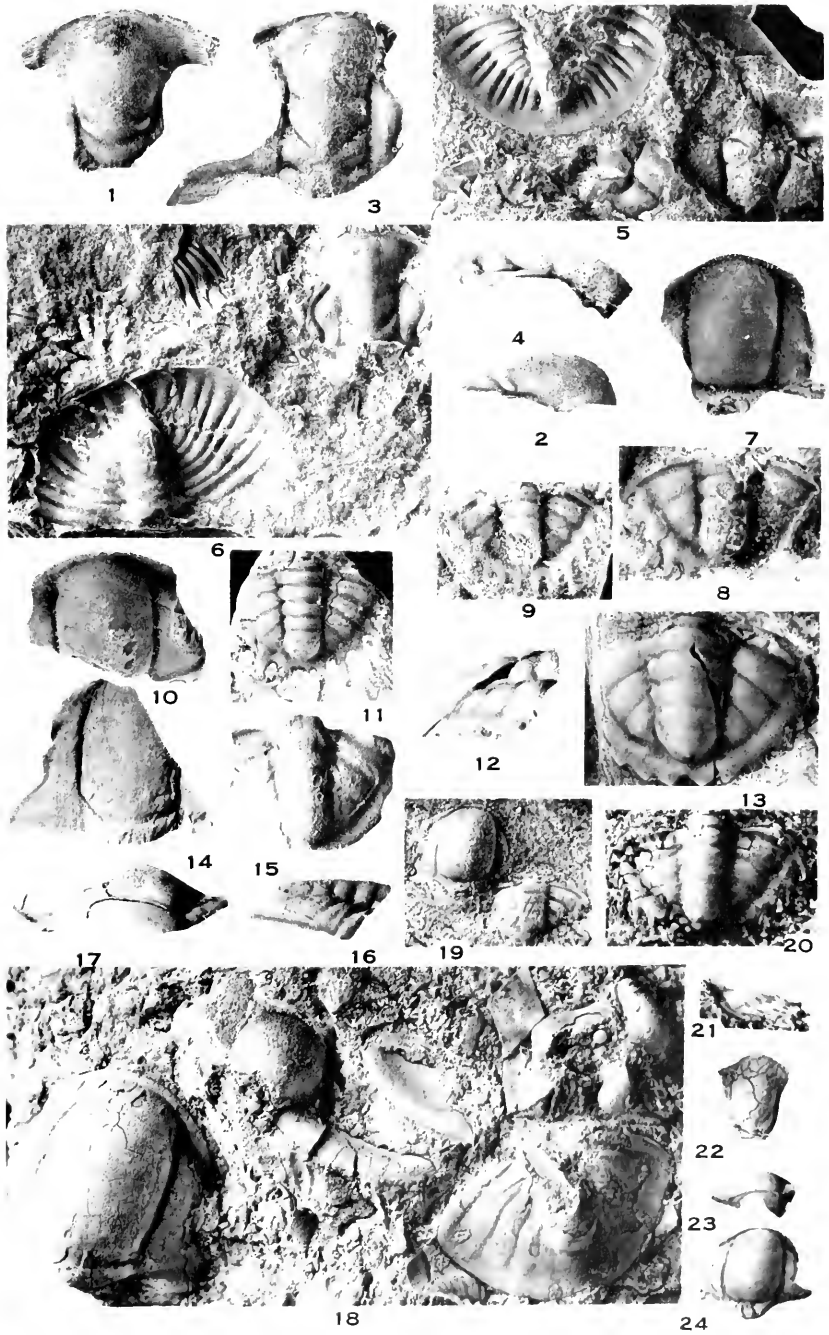

CLAVASPIDELLA AND KOOTENIA  
(See explanation of plates at end of text.)

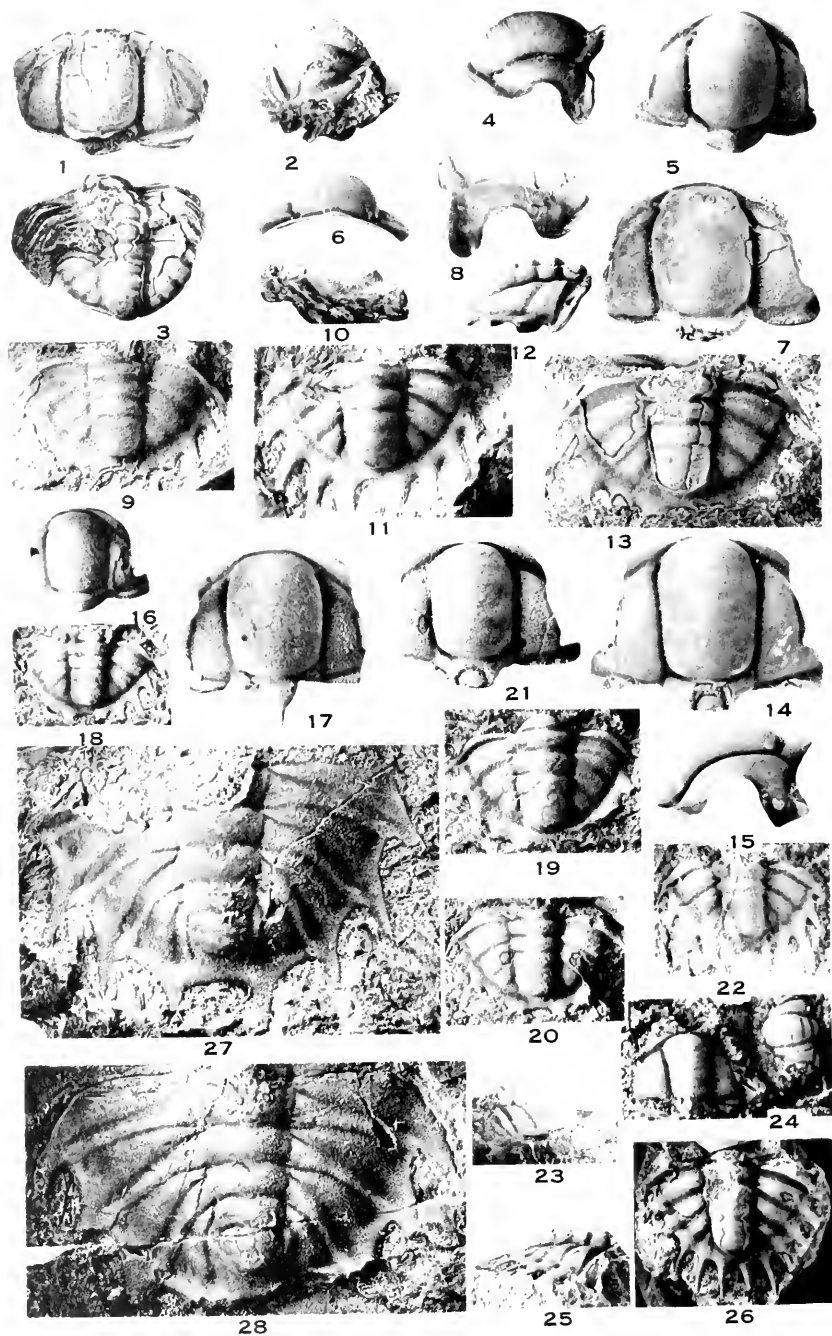

KOOTENIA AND OLENOIDES  
 (See explanation of plates at end of text.)

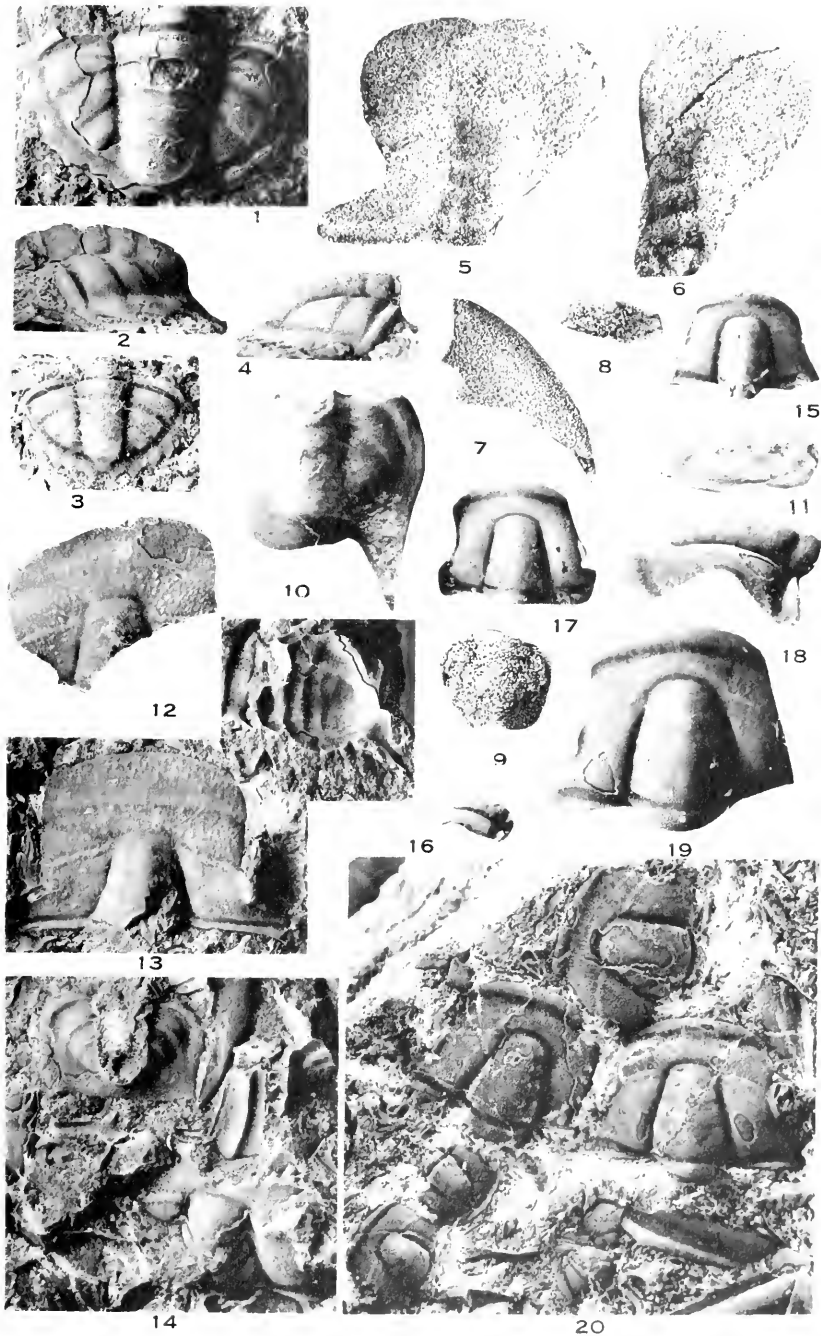

KOOTENIA, KOCHIELLA, PACHYASPIS  
(See explanation of plates at end of text.)

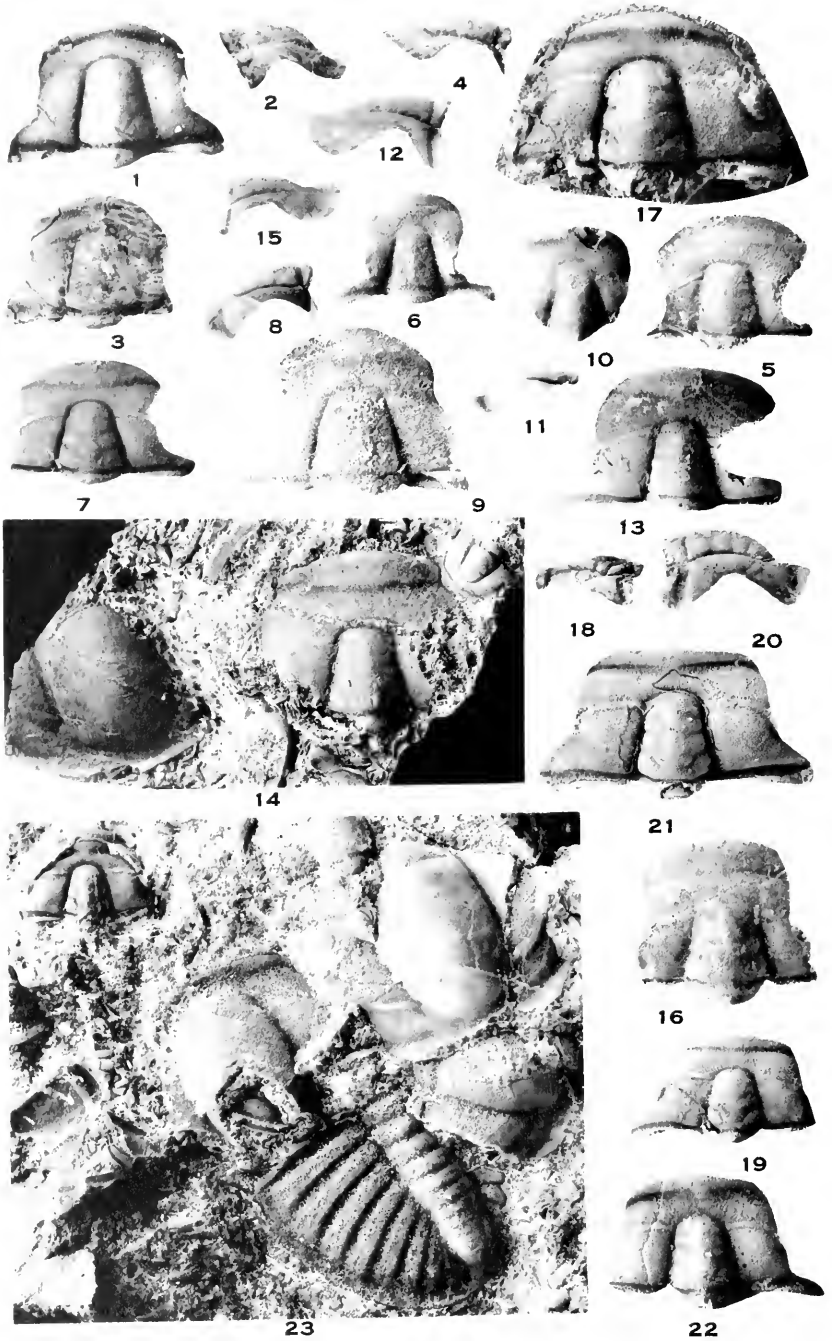

TRILOBITES

(See explanation of plates at end of text.)

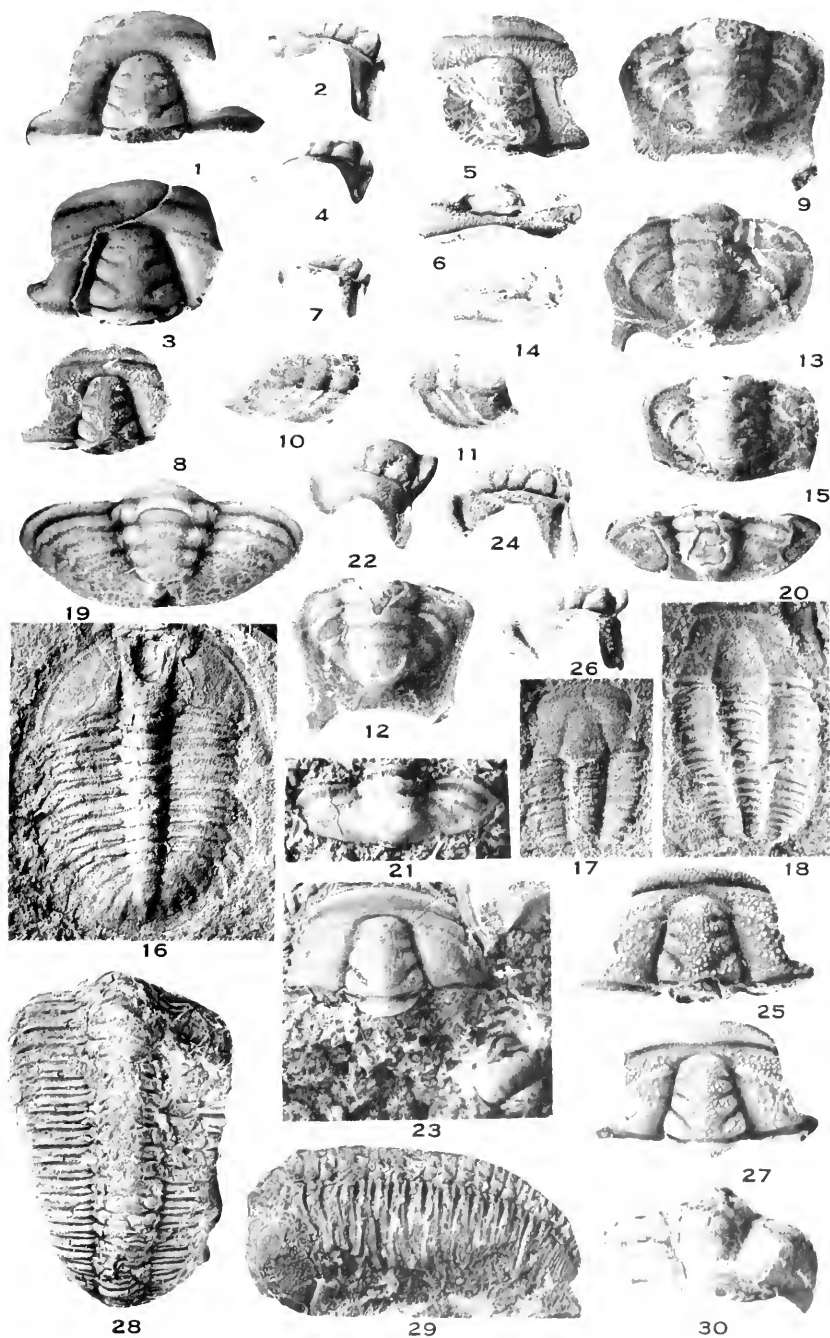

KOCHASPIS, POULSENIA, AND OTHER TRILOBITES  
(See explanation of plates at end of text.)

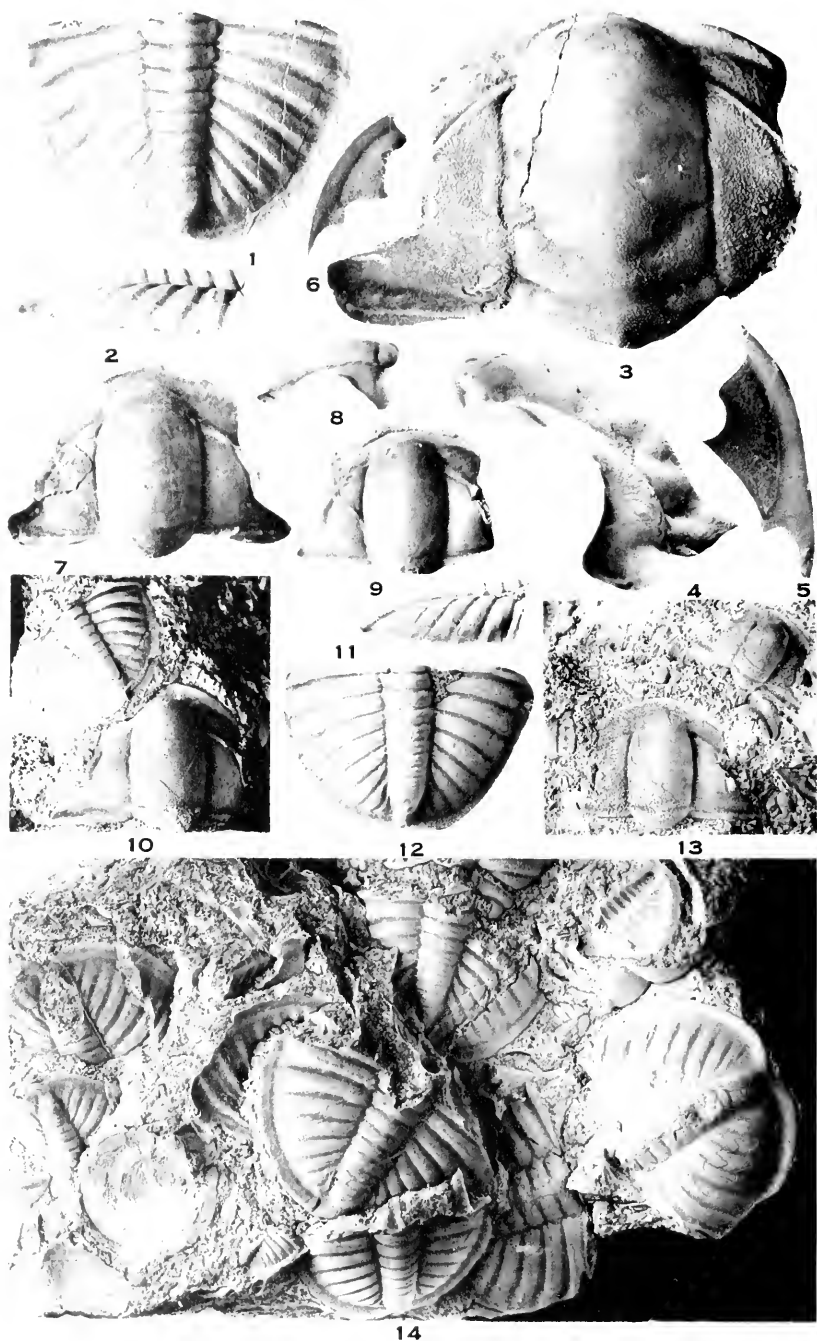

TAXIOIRA

(See explanation of plates at end of text.)

SMITHSONIAN MISCELLANEOUS COLLECTIONS

VOLUME 98, NUMBER 25

LIST OF THE FISHES TAKEN ON THE  
PRESIDENTIAL CRUISE OF 1938

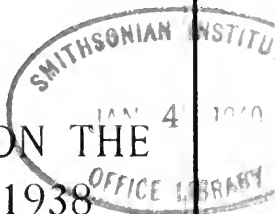

BY  
WALDO L. SCHMITT  
AND  
LEONARD P. SCHULTZ  
U. S. National Museum



(PUBLICATION 3551)

CITY OF WASHINGTON  
PUBLISHED BY THE SMITHSONIAN INSTITUTION  
JANUARY 4, 1940

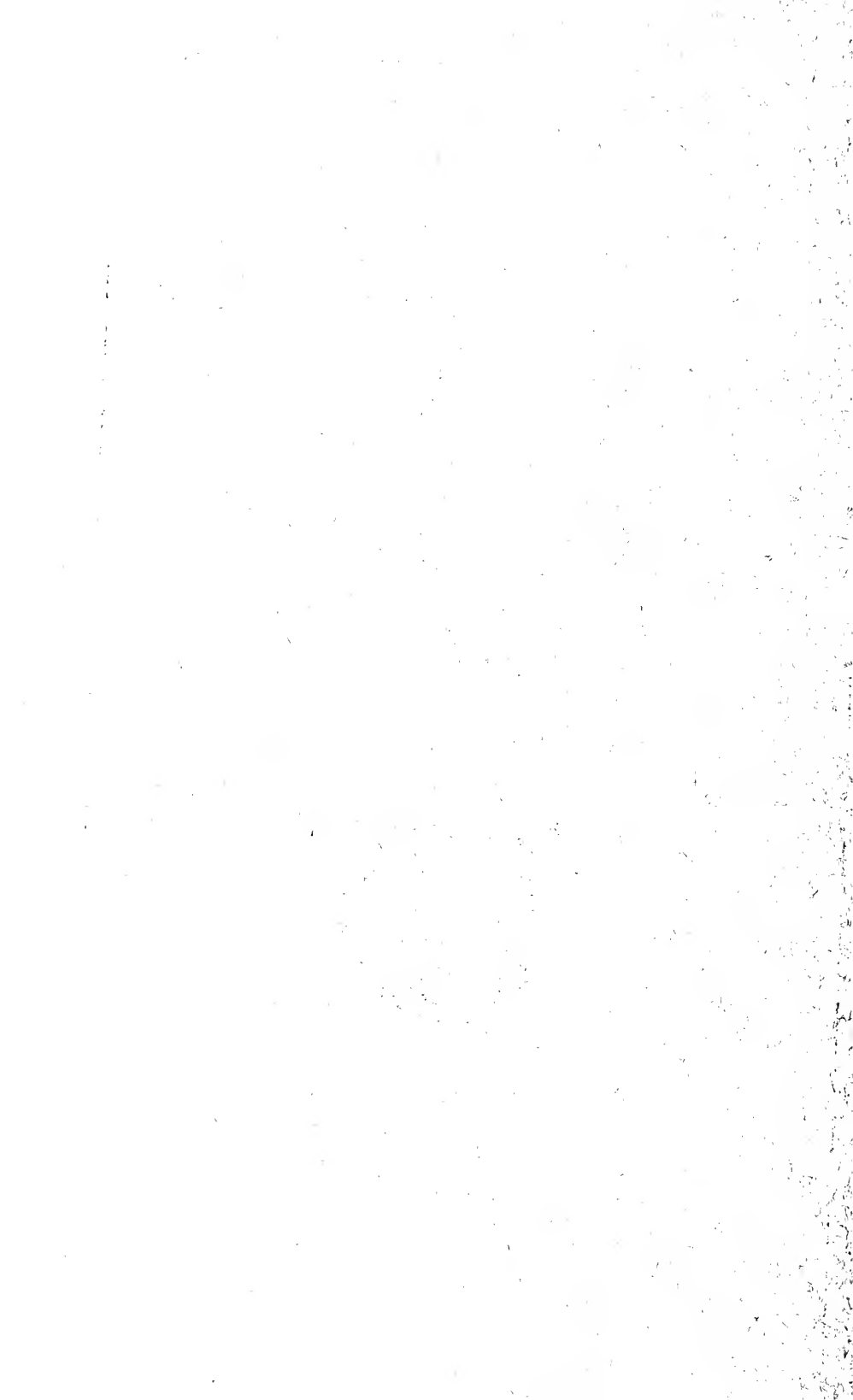



SMITHSONIAN MISCELLANEOUS COLLECTIONS  
VOLUME 98, NUMBER 25

LIST OF THE FISHES TAKEN ON THE  
PRESIDENTIAL CRUISE OF 1938

BY  
WALDO L. SCHMITT  
AND  
LEONARD P. SCHULTZ  
U. S. National Museum



(PUBLICATION 3551)

CITY OF WASHINGTON  
PUBLISHED BY THE SMITHSONIAN INSTITUTION  
JANUARY 4, 1940

*The Lord Baltimore Press*  
BALTIMORE, MD., U. S. A.

# LIST OF THE FISHES TAKEN ON THE PRESIDENTIAL CRUISE OF 1938

By WALDO L. SCHMITT and LEONARD P. SCHULTZ  
*U. S. National Museum*

This list comprises only those fishes collected on the Presidential Cruise of 1938 which have actually been incorporated in the study collections of the United States National Museum. President Roosevelt, himself an ardent fisherman and keen naturalist, was the principal contributor of the specimens listed. Not only did he obtain some rarities, but he also succeeded in establishing maximum weight records for two species: 20 pounds for the rainbow runner, *Elagatis bipinnulatus*, and 38 pounds for the blue crevally, *Caranx stellatus*. The President was most ably assisted by the members of his personal party: Frederick B. Adams; Basil O'Connor; Stephen T. Early, the President's Secretary; Capt. Ross T. McIntire, Medical Corps, U.S.N., Aide; Capt. D. J. Callaghan, U.S.N., Naval Aide; and Col. Edwin W. Watson, U.S.A., Military Aide. Dr. Schmitt, by invitation of the President, was naturalist to the expedition.<sup>1</sup>

The officers and members of the crew of the U.S.S. *Houston*, on which the cruise was made, also collected many fishes, some of which are included in this list.

All specimens brought back to the Museum for its permanent collections were identified by Dr. Schultz and Earl D. Reid, senior scientific aid, Division of Fishes, National Museum. The authors wish to express their thanks to Mr. Reid for his cooperation, and they are grateful also for assistance rendered by Dr. S. F. Hildebrand and Isaac Ginsburg, both of the United States Bureau of Fisheries.

---

<sup>1</sup>A first listing of the fishes taken on the Presidential Cruise, together with remarks upon certain of the specimens preserved and notes on others observed in the field but not saved, was published by Dr. Schmitt as an "Annotated List of the Fishes," appended to the "Log [of] The Cruise 1938," by Capt. D. J. Callaghan, U.S.N., Naval Aide to the President, with following title page: "The Inspection Cruise and Fishing Expedition of President Franklin D. Roosevelt on Board U.S.S. *Houston* 16 July 1938-9 August 1938." Privately printed and distributed during the month of November 1938.

The collection proved to be of great value, for it contained nine species not represented in the Museum's study collections. Two of these, *Pycnomma roosevelti* and *Garmannia gemmata*, were described as new by Mr. Ginsburg.<sup>2</sup>

Family DUSSUMIERIIDAE: Round herring

**Etrumeus micropus** Temminck and Schlegel

Galápagos Islands, South Seymour Island, picked up on beach at north end, plateau-land section of island, July 29, 1938. U.S.N.M. No. 107049. 2 specimens.

Family MURAENIDAE: Morays

**Uropterygius necturus** (Jordan and Gilbert)

Clipperton Island, shore rocks, July 21, 1939. U.S.N.M. No. 107047. 2 specimens.

Family FISTULARIDAE: Cornetfishes

**Fistularia petimba** Lacépède

Galápagos Islands, James Island, Sullivan Bay, shore and tide pools, 3:30 to 5:00 p.m., July 24, 1938. U.S.N.M. No. 109958. 1 skeleton.

Family MUGILIDAE: Mulletts

\* **Mugil setosus** Gilbert

Mexico, Braithwaite Bay, Socorro Island, shore, July 20, 1938. U.S.N.M. No. 107050. 1 specimen.

**Querimana curema** (Cuvier and Valenciennes)

Galápagos Islands, Albemarle Island, off Tagus Cove, 11:00 p.m., dip net, electric light off gangway, July 25, 1938. U.S.N.M. No. 107051. 15 specimens.

Family SPHYRAENIDAE: Barracudas

**Sphyraena idiaestes** Heller and Snodgrass. Southern barracuda

Galápagos Islands, Albemarle Island, off Tagus Hill, July 25, 1938. U.S.N.M. No. 107052. 1 specimen.

<sup>2</sup> Smithsonian Misc. Coll., vol. 98, No. 14, pp. 1-5, May 31, 1939.

\* New to U. S. National Museum Collections.

Galápagos Islands, Hood Island, July 28, 1938. U.S.N.M. No. 107053. 2 specimens.

Galápagos Islands, north end South Seymour Island, July 29, 1938. U.S.N.M. No. 107054. 3 specimens.

Family HOLOCENTRIDAE: Soldierfishes, squirrelfishes

**Holocentrus vexillarius** Poey

Caribbean Sea, Old Providence Island, shore, August 6, 1938. U.S.N.M. No. 107064. 2 specimens.

Family THUNNIDAE: Tunnies, albacores

**Sarda velox** Meek and Hildebrand. Mexican bonito

Galápagos Islands, July 24-30, 1938. U.S.N.M. No. 107055. 1 specimen.

Family KATSUWONIDAE: Victorfishes

**Euthynnus lineatus** Kishinouye. Black skipjack

Galápagos Islands, from off north end of South Seymour Island, July 29, 1938. U.S.N.M. No. 107057. 2 specimens.

Galápagos Islands, Hood Island, July 28, 1938. U.S.N.M. No. 107058. 1 specimen.

**Euthynnus alletteratus** (Rafinesque)

Galápagos Islands, Albemarle Island, Tagus Channel, July 25, 1938. U.S.N.M. No. 107056. 1 specimen.

First taken on the cruise in the Galápagos at three or more stops including Tagus Channel, and Sullivan Bay, James Island; the heaviest one caught weighed about 17 pounds. Although known from the warmer waters of the Pacific and Atlantic, these represent a first Galápagos record. There may be some question as to the identity of this species. Anatomically it seems to differ little from *Euthynnus lineatus* (Kishinouye), over which it may take precedence as the earlier named species. The color and color pattern of the two are very different and, if not due to variation, will serve for ready recognition of the two forms in the field. One specimen from Tagus Channel, Albemarle Island, July 25, 1938, was saved. The color and pattern of the markings on the back of this fish, at first glance appear very much like those of the Pacific mackerel as figured by Walford in color in his "Marine Game Fishes" (pl. 37, fig. b). Also the color note given by Hildebrand in Meek and Hildebrand, "The Marine Fishes of Panama," p. 311, 1923, appears to fit our specimen.

## Family ACANTHOCYBIIDAE: Wahoo

\* *Acanthocybium solandri* (Cuvier and Valenciennes)

Cocos Island, August 1, 1938. U.S.N.M. No. 107059. 1 specimen.

Galápagos Islands, Hood Island, July 28, 1938. U.S.N.M. No. 107060. 2 specimens.

The heaviest wahoo taken weighed 54 pounds and was caught at Hood by Colonel Watson the afternoon of July 28. "Gamest fish of trip. Red, or red and white feather is best lure."

## Family CARANGIDAE: Pampanos

*Elagatis bipinnulatus* (Quoy and Gaimard). Rainbow runner

Cocos Island, August 1, 1938. U.S.N.M. No. 107061. 1 specimen, weight 20 pounds.

Several specimens were taken at Cocos Island, August 1. The President got the heaviest one, which was saved; fresh weight 20 pounds, a record. Heretofore, the weight of this species has been given as "at least 12 pounds."

*Seriola mazatlanana* Steindachner. Mazatlan yellowtail

Galápagos Islands, Albemarle Island, Tagus Cove, July 25, 1938. U.S.N.M. No. 107062. 1 specimen.

\* *Seriola colburni* Evermann and Clark. Pacific amberjack

Galápagos Islands, off Hood Island, July 28, 1939. U.S.N.M. No. 107063. 2 specimens.

Taken off Hood Island, July 28, and South Seymour, July 29. Heaviest about 28 pounds. The larger of the two Hood Island specimens saved weighed 24 pounds here at the Museum after having been pickled in formalin and then alcohol for some days. This appears to be the first definite record of this species from the Galápagos Islands.

*Caranx stellatus* Eydoux and Souleyet. Blue crevally

Mexico, Lower California, off San José del Cabo Bay, from fishing banks, July 19, 1938. U.S.N.M. No. 107119. 1 specimen.

Taken off Cape San Lucas, Socorro and Cocos Islands. The heaviest of several specimens was caught by the President at Socorro, July 20. It weighed about 38 pounds, a record for the species. Heretofore, the weight of this species has merely been recorded as "more than 20 pounds."

\* New to U. S. National Museum Collections.

**Caranx marginatus** Gill

Mexico, Socorro Island, July 20, 1938. U.S.N.M. No. 107185. 2 specimens.

## Family SERRANIDAE: Groupers, sea basses

**Epinephelus labriformis** (Jenyns). Flag cabrilla

Galápagos Islands, James Island, Sullivan Bay, tide pools, July 24, 1938. U.S.N.M. No. 107067. 2 specimens.

Galápagos Islands, Charles Island, Post Office Bay, July 27, 1938. U.S.N.M. No. 107068. 1 specimen.

Mexico, Socorro Island, July 20, 1938. U.S.N.M. No. 107179. 1 specimen.

**Epinephelus analogus** Gill. Spotted cabrilla

Mexico, Socorro Island, July 20, 1938. U.S.N.M. No. 107070. 1 specimen.

**Alphestes multiguttatus** (Günther). Pacific guaseta

Galápagos Islands, James Island, Sullivan Bay, shore and tide pools, 3:30 to 5:00 p.m., tide beginning to run out, July 24, 1938. U.S.N.M. No. 107069. 1 specimen.

\* **Mycteroperca jordani** (Jenkins and Evermann). Gulf grouper

Mexico, Lower California, off San José del Cabo Bay, July 19, 1938. U.S.N.M. No. 107065. 1 specimen, weight 20 pounds.

**Mycteroperca olfax** (Jenyns). Colorado grouper, golden grouper

Galápagos Islands, Albemarle Island, Elizabeth Bay, July 26, 1938. U.S.N.M. No. 107066. 1 specimen.

The yellow or golden grouper of the Galápagos Islands is but a color phase of the Colorado grouper. The heaviest, 19 pounds, was caught by Mr. Early at Sullivan Bay, James Island, July 24. Colonel Watson also caught one of this weight the day following off Tagus Cove, Albermarle Island. Two others were taken off Hood Island, July 28.

**Cratinus agassizii** Steindachner. Gray threadfin bass

Galápagos Islands, Albemarle Island, Elizabeth Bay, July 20, 1938. U.S.N.M. No. 107071. 4 specimens.

Galápagos Islands, Albermarle Island, off Tagus Cove, July 25, 1938. U.S.N.M. No. 107072. 1 specimen.

Galápagos Islands, Albemarle Island, Elizabeth Bay. U.S.N.M. No. 107120. 1 specimen.

\* New to U. S. National Museum Collections.

A gray threadfin bass eaten by the President's Mess was pronounced "very good eating." This species was also found at South Seymour Island, July 29.

***Paranthias furcifer* (Cuvier and Valenciennes).** Southern creolefish

Galápagos Islands, Hood Island, Gardner Bay, July 28, 1938. U.S.N.M. No. 107073. 6 specimens.

***Paralabrax albomaculatus* (Jenyns).** White-spotted rock bass

Galápagos Islands, Albemarle Island, on west side, July 26, 1938. U.S.N.M. No. 107074. 1 specimen.

Galápagos Islands, Albemarle Island, Tagus Cove, July 25, 1938. U.S.N.M. No. 107075. 6 specimens.

Abundant on the west side of Albemarle Island, July 25 to 26; over a washtub full was taken on the second of the two days by members of the crew fishing over the side.

***Paralabrax clathratus* (Girard)**

Mexico, Cedros Island, July 17, 1938. U.S.N.M. No. 107186. 2 specimens.

#### Family LUTIANIDAE: Snappers

***Evoplites viridis* (Valenciennes).** Blue and gold snapper

Cocos Island, August 1, 1938. U.S.N.M. No. 107076. 2 specimens.

#### Family HAEMULIDAE: Grunts

***Orthopristis forbesi* Jordan and Starks in Gilbert**

Galápagos Islands, South Seymour Island, July 29, 1938. U.S.N.M. No. 107077. 1 specimen.

#### Family KYPHOSIDAE: Pilotfishes

\* ***Doydixodon freminvillei* Valenciennes**

Galápagos Islands, James Island, Sullivan Bay, tide pool, July 24, 1938. U.S.N.M. No. 107078. 15 specimens.

#### Family POMACENTRIDAE: Damselfishes

***Pomacentrus leucurus* Gilbert**

Galápagos Islands, Narborough Island, shore, July 25, 1938. U.S.N.M. No. 107079. 2 specimens.

\* New to U. S. National Museum Collections.



Galápagos Islands, Hood Island, Gardner Bay, inshore fishing, July 28, 1938. U.S.N.M. No. 107080. 1 specimen.

Galápagos Islands, James Island, Sullivan Bay, July 24, 1938. U.S.N.M. No. 107081. 2 specimens.

***Pomacentrus arcifrons* Heller and Snodgrass**

Galápagos Islands, James Island, Sullivan Bay, tide pool, July 24, 1938. U.S.N.M. No. 107082. 2 specimens.

Galápagos Islands, Charles Island, Post Office Bay, shore, July 27, 1938. U.S.N.M. No. 107083. 4 specimens.

***Eupomacentrus leucostictus* (Müller and Troschel)**

Caribbean Sea, Old Providence Island, reef and tide pool in forenoon, August 6, 1938. U.S.N.M. No. 107090. 13 specimens.

***Abudefduf saxatilis* (Linnaeus)**

Galápagos Islands, James Island, Sullivan Bay, tide pool, July 24, 1938. U.S.N.M. No. 107087. 27 specimens.

Caribbean Sea, Old Providence Island, shore, August 6, 1938. U.S.N.M. No. 107088. 4 specimens.

***Abudefduf analogus* (Gill)**

Galápagos Islands, James Island, Sullivan Bay, tide pools, July 24, 1938. U.S.N.M. No. 107089. 1 specimen.

**\* *Nexilosus albemarleus* Heller and Snodgrass**

Galápagos Islands, Narborough Island, July 25, 1938. U.S.N.M. No. 107084. 1 specimen.

Galápagos Islands, Albemarle Island, Tagus Cove, July 25, 1938. U.S.N.M. No. 107085. 3 specimens.

***Azurina eupalama* Heller and Snodgrass**

Galápagos Islands, Hood Island, Gardner Bay, dip net, 11:00 p.m., off gangway at anchorage, July 27, 1938. U.S.N.M. No. 107086. 1 specimen.

Family SPARISOMIDAE: Parrotfishes

***Sparisoma rubripinne* (Cuvier and Valenciennes)**

Caribbean Sea, Old Providence Island, shore, August 6, 1938. U.S.N.M. No. 107092. 4 specimens.

\* New to U. S. National Museum Collections.

***Sparisoma hoplomystax* (Cope)**

Caribbean Sea, Old Providence Island, dredge haul in 7 to 8 fathoms inside reef, Catalina Harbor, August 6, 1938. U.S.N.M. No. 107093. 1 specimen.

Family LABRIDAE: Wrasses. Lipped fishes

***Pimelometopon darwinnii* (Jenyns). Sheepshead**

Galápagos Islands, South Seymour Island, July 29, 1938. U.S.N.M. No. 107094. 1 specimen.

***Bodianus diplotaenia* (Gill)**

Cocos Island, August 1, 1938. U.S.N.M. No. 107095. 2 specimens.

***Thalassoma grammaticum* Gilbert**

Cocos Island, August 1, 1938. U.S.N.M. No. 107096. 2 specimens.

Family ACANTHURIDAE: Surgeonfishes

***Hepatus triostegus* (Linnaeus)**

Clipperton Island, July 21, 1938. U.S.N.M. No. 107098. 1 specimen.

Family ELEOTRIDAE: Sleepers, gobies

**\* *Pycnomma roosevelti* Ginsburg**

Caribbean Sea, Old Providence Island, August 6, 1938. U.S.N.M. No. 108139, holotype; No. 107108, paratype. 2 specimens.

Family GOBIIDAE: Gobies

***Bathygobius lineatus* (Jenyns)**

Galápagos Islands, James Island, Sullivan Bay, tide pools, July 24, 1938. U.S.N.M. No. 107106. 24 specimens.

Galápagos Islands, Charles Island, Post Office Bay, July 27, 1938. U.S.N.M. No. 107121. 1 specimen.

***Bathygobius soporator* (Cuvier and Valenciennes)**

Caribbean Sea, Old Providence Island, shore, reef, and tide pools, August 6, 1938. U.S.N.M. No. 107107. 3 specimens.

**\* *Garmania gemmata* Ginsburg**

Caribbean Sea, Old Providence Island, August 6, 1938. U.S.N.M. No. 107291, holotype; No. 107109, paratype. 2 specimens.

\* New to U. S. National Museum Collections.

## Family ECHENEIDIDAE: Remoras, sharkpilots

**Echeneis remora** Linnaeus

Cocos Island, August 2, 1938. U.S.N.M. No. 107117. 4 specimens.

Cocos Island, forenoon, August 3, 1938, taken from 116 pound sail-fish. U.S.N.M. No. 107118. 2 specimens.

## Family CLINIDAE: Southern blennies

**Malacoctenus culebrae** Evermann and Marsh

Caribbean Sea, Old Providence Island, shore, August 6, 1938. U.S.N.M. No. 107110. 2 specimens.

**Malacoctenus zonogaster** Heller and Snodgrass

Galápagos Islands, James Island, Sullivan Bay, tide pools, July 24, 1938. U.S.N.M. No. 107111. 8 specimens.

**Malacoctenus bigutatus** (Cope)

Caribbean Sea, Old Providence Island, shore, August 6, 1938. U.S.N.M. No. 107112. 1 specimen.

**Labrisomus herminier** (LeSueur)

Caribbean Sea, Old Providence Island, shore, August 6, 1938. U.S.N.M. No. 107113. 2 specimens.

**Labrisomus nuchipinnis** (Quoy and Gaimard)

Caribbean Sea, Old Providence Island, shore, August 6, 1938. U.S.N.M. No. 107114. 2 specimens.

**Auchenistius stahli** Evermann and Marsh

Caribbean Sea, Old Providence Island, shore, August 6, 1938. U.S.N.M. No. 107115. 5 specimens.

\* **Auchenopterus fajardo** Evermann and Marsh

Caribbean Sea, Old Providence Island, shore, August 6, 1938. U.S.N.M. No. 107116. 3 specimens.

## Family BALISTIDAE: Triggerfishes

**Melichthys radula** (Solander)

Clipperton Island, July 21, 1938. U.S.N.M. No. 107099. 3 specimens.

Cocos Island, at north end, August 1, 1938. U.S.N.M. No. 107100. 1 specimen.

\* New to U. S. National Museum Collections.

The Clipperton Island specimens were caught by the President with trout hook and pole with bit of fish skin as bait, while they were schooling at the surface.

Family TETRAODONTIDAE: Puffers

**Sphoeroides annulatus (Jenyns)**

Galápagos Islands, Albemarle Island, Elizabeth Bay, July 26, 1938. U.S.N.M. No. 107101. 2 specimens.

Galápagos Islands, South Seymour Island, July 29, 1938. U.S.N.M. No. 107102. 1 specimen.

**Tetraodon hispidus Linnaeus**

Clipperton Island, shore, collecting on rocks, July 21, 1938. U.S.N.M. No. 107103. 1 specimen.

Family CANTHIGASTERIDAE: Sharp-nosed puffers

**Canthigaster rostratus (Bloch)**

Caribbean Sea, Old Providence Island, August 6, 1938. U.S.N.M. No. 107105. 1 specimen.







SMITHSONIAN INSTITUTION LIBRARIES



3 9088 01421 4878