

UC-NRLF



\$B 278 819

SOLID GEOMETRY

WALTER - LINT - TOUTON

1316

5

IN MEMORIAM
FLORIAN CAJORI

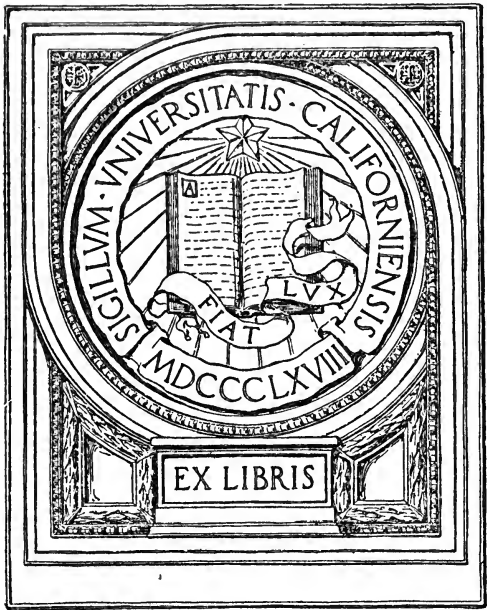

EX LIBRIS

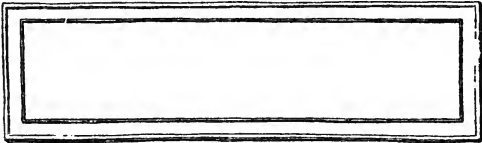

Floriana Cajoni

SOLID GEOMETRY

Univ. of
California

BY

HERBERT E. HAWKES, Ph.D.

PROFESSOR OF MATHEMATICS IN COLUMBIA UNIVERSITY

WILLIAM A. LUBY, M.A.

HEAD OF THE DEPARTMENT OF MATHEMATICS IN THE
JUNIOR COLLEGE OF KANSAS CITY

AND

FRANK C. TOUTON, Ph.D.

LECTURER IN EDUCATION, DEPARTMENT OF EDUCATION
UNIVERSITY OF CALIFORNIA



GINN AND COMPANY

BOSTON · NEW YORK · CHICAGO · LONDON
ATLANTA · DALLAS · COLUMBUS · SAN FRANCISCO

QA 457
H 34

TO THE
LIBRARY OF

COPYRIGHT, 1922, BY
HERBERT E. HAWKES, WILLIAM A. LUBY
AND FRANK C. TOUTON

ALL RIGHTS RESERVED
322.4

AJORI

The Athenæum Press
GINN AND COMPANY · PRO-
PRIETORS · BOSTON · U.S.A.

PREFACE

During recent years the study of solid geometry has occupied a somewhat less commanding position in the mathematical curriculum than formerly. Important and essential as its subject matter is admitted to be, it has been little more than an appendage to plane geometry, both in the methods of its presentation and in its scientific results.

The authors of this text feel that the subject is much more vital than such a tendency would indicate. Not only are the bare truths gained from a study of solid geometry essential to the student of science, but through its medium a multitude of mathematical ideas can be presented and elucidated in a natural and convincing manner. In fact, no subject of elementary mathematics can be compared to solid geometry as a climax and capstone of mathematical study for the student who pursues the subject no farther. It not only utilizes and applies much that he has learned in other courses, but serves as a point of vantage from which may be gained many glimpses of scientific fields which he is not to enter.

In this text the authors have presented the subject in such form that a minimal course as prescribed by the colleges and the various examining boards may be covered. At the same time it affords at every turn a richness of suggestion and development for those who have the time and the inclination to do more than that minimum.

One of the important opportunities afforded by the study of solid geometry is that of using and developing the scientific

imagination. This text, through its hundreds of queries, aims to encourage the student to regard the subject not merely as a logical sequence of theorems but as a subject inviting reflection and the play of speculation. These queries should be used in class as a basis for discussion and will be found to render the more formal work not only more interesting but more intelligible. If time does not permit any attention to the queries, they may be omitted from the class assignments without disturbing the continuity of the subject. Their use, however, is strongly urged by the authors.

Exercises illustrating or dependent upon the various theorems are scattered throughout the text and afford as much drill of this kind as many teachers can profitably use. The collections at the end of each book may be regarded as supplementary. Great care has been exercised to provide a collection of originals that is fresh, interesting, not too difficult, but illustrating all parts of the subject.

The assumption of Cavalieri's Theorem as a basis for the theorems on measurement is the result of many years of classroom experience. The simplicity and power of this procedure should commend it both to teachers and to students.

The geometry of the sphere and its relation to plane geometry is also elaborated with care and in such a manner as to give the student an insight into the meaning of geometrical science.

CONTENTS

	PAGE
BOOK VI. LINES AND PLANES	303
Parallel Lines and Planes	311
Perpendicular Lines and Planes	324
Angles between Planes	339
Projections	349
Skew Lines	354
BOOK VII. POLYHEDRONS, CONES, AND CYLINDERS	358
Volumes	365
Cylinders	375
Pyramids	387
Cones	405
Polyhedrons	419
BOOK VIII. THE SPHERE	443
General Properties of the Sphere	443
Measurement of the Sphere	452
Geometry on the Sphere	464
INDEX	493

Digitized by the Internet Archive
in 2007 with funding from
Microsoft Corporation

REFERENCES FROM PLANE GEOMETRY

POSTULATES AND AXIOMS

19. Postulate I. There is only one straight line through two points.

20. Postulate II. Any geometric figure may be moved from one place to another without changing its size or shape.

31. Axiom I. If equals are added to equals, the results are equal.

32. Axiom II. (1) Two numbers or magnitudes each equal to a third are equal to each other. (2) Two figures congruent to a third are congruent to each other.

36. Postulate III. All straight angles are equal.

39. Axiom III. If equals are divided by the same number, the results are equal.

41. Postulate IV. At a given point of a line, one and only one perpendicular can be drawn to the line.

45. Postulate V. The postulate of parallels. Through a given point outside a line, one line parallel to it exists, and only one.

51. Axiom IV. If equals are subtracted from equals, the results are equal.

65. Axiom V. A number may be substituted for its equal in any operation on numbers.

124. Axiom VI. If equals are multiplied by equals, the results are equal.

136. Axiom VII. The whole is greater than any of its parts.

137. Axiom VIII. If the first of three magnitudes is greater than the second and the second is greater than the third, the first is greater than the third.

139. Axiom IX. If the same number, positive or negative, is added to or subtracted from each member of an inequality, the results are unequal in the same order.

140. Axiom X. If both members of an inequality are multiplied or divided by the same positive number, the results are unequal in the same order.

141. Axiom XI. If the corresponding members of two or more inequalities which are in the same order are added, the sums are unequal in the same order.

142. Axiom XII. If unequals are subtracted from equals, the results are unequal in the reverse order.

146. Postulate VI. Any side of a triangle is less than the sum of the other two sides.

DEFINITIONS

15. Angle. A plane angle (symbol \sphericalangle) is the figure formed by two rays which meet.

16. Triangle. A triangle (symbol \triangle) is a portion of a plane bounded by three straight lines.

24. Congruence. Two geometric magnitudes are congruent if their boundaries can be made to coincide.

30. Isosceles triangle. An isosceles triangle is a triangle which has two equal sides.

37. Perpendicular. If one straight line cuts another so as to make any two adjacent angles equal, each line is perpendicular (symbol \perp) to the other.

43. Parallel lines. Parallel lines are lines that lie in the same plane and do not meet however far they are produced.

49. Hypotenuse. The hypotenuse of a right triangle is the side opposite the right angle.

52. Vertical angles. Two angles are vertical angles if the sides of one are the prolongations of the sides of the other.

54. Transversal. A transversal is a line that crosses (cuts or intersects) two or more lines.

61. Supplementary angles. One angle is the supplement of another if their sum equals two right angles (or 180°).

79. Regular polygon. A regular polygon is a polygon all of whose angles are equal and all of whose sides are equal.

80. Diagonal. A diagonal of a polygon is a line joining any two nonconsecutive vertices.

83. Parallelogram. A parallelogram is a quadrilateral whose opposite sides are parallel.

84. Rectangle. A rectangle is a parallelogram whose angles are right angles.

107. Trapezoid. A trapezoid is a quadrilateral two and only two of whose sides are parallel.

119. Concurrent lines. Three or more lines which have one point in common are said to be concurrent.

154. Circle. A circle is a closed plane curve every point of which is equally distant from a point in the plane of the curve.

187. Tangent. A tangent to a circle is a straight line which, however far it may be produced, has only one point in common with the circle.

233. Altitude of a triangle. An altitude of a triangle is a perpendicular from any vertex to the side opposite, produced if necessary.

242. Locus. A locus is a figure containing all the points, and only those points, which fulfill a given requirement.

267. Similar polygons. Two polygons are similar (symbol \sim) if the angles of one are equal respectively to the angles of the other and the sides are proportional each to each.

310. Area. The area of a plane figure is the number which expresses the ratio between its surface and the surface of the unit square.

354. Center of polygon. The center of a regular polygon is the common center of its inscribed and circumscribed circles.

363. Definition of π . The number π (pronounced pī), used in calculations on the circle, is the number obtained by dividing the circumference of a circle by its diameter; that is, $\pi = \frac{C}{D}$. From the above, $C = \pi D$ or $C = 2\pi R$.

PROPOSITIONS

25. If two sides and the included angle of one triangle are equal respectively to two sides and the included angle of another, the two triangles are congruent.

27. Corresponding parts of congruent figures are equal.

29. If two sides of a triangle are equal, the angles opposite them are equal.

33. If the three sides of one triangle are equal respectively to the three sides of another, the triangles are congruent.

42. There is only one perpendicular from a point to a line.

44. Two lines perpendicular to the same line are parallel.

46. If a line intersects one of two parallel lines, it intersects the other also.

47. If a line is perpendicular to one of two parallel lines, it is perpendicular to the other also.

50. Two right triangles are congruent if the hypotenuse and an adjacent angle of one are equal respectively to the hypotenuse and an adjacent angle of the other.

53. If two straight lines intersect, the vertical angles are equal.

57. If two parallel lines are cut by a transversal, the alternate-interior angles are equal.

66. The sum of the angles of any triangle is two right angles.

76. If two angles have their sides perpendicular each to each, they are equal or supplementary.

82. If a side and the two adjacent angles of one triangle are equal respectively to a side and the two adjacent angles of another, the triangles are congruent.

85. The opposite sides of a parallelogram are equal.

88. If two sides of a quadrilateral are equal and parallel, the figure is a parallelogram.

90. The diagonals of a parallelogram bisect each other.

97. Two right triangles are congruent if the hypotenuse and another side of the first are equal respectively to the hypotenuse and another side of the second.

98. Two right triangles are congruent if a side about the right angle and an acute angle of the first are equal respectively to a side about the right angle and a corresponding angle of the second.

116. If a point is on the mid-perpendicular of a line, it is equidistant from the ends of the line.

117. If a point is equidistant from the ends of a line, it is on the mid-perpendicular of the line.

118. Two points each equally distant from the extremities of a line determine the mid-perpendicular of the line.

121. If a point is on the bisector of an angle, it is equally distant from the sides of the angle.

122. If a point is equally distant from the sides of an angle, it is on the bisector of the angle.

125. If n is the number of sides of a convex polygon and s is the sum of its interior angles, then $s = (2n - 4)$ right angles.

128. If two lines are parallel to a third line, the two lines are parallel to each other.

130. If a line bisects one side of a triangle and is parallel to another side, it bisects the third side.

131. The line which joins the mid-points of two sides of a triangle is parallel to the third side and equal to one half of it.

133. The line joining the mid-points of the nonparallel sides of a trapezoid is parallel to the bases and equal to half their sum.

143. The medians of a triangle are concurrent in the basal point of trisection of each.

145. If two sides of a triangle are unequal, the angles opposite them are unequal and the greater angle lies opposite the greater side.

149. The perpendicular from a point outside a straight line is the shortest line from the point to the line.

151. If two triangles have two sides of one equal respectively to two sides of the other and the third side of the first greater than the third side of the second, the included angle of the first is greater than the included angle of the second.

171. In the same circle or in equal circles if two central angles are equal, their intercepted arcs are equal.

174. In the same circle or in equal circles, if two arcs are equal, they subtend equal central angles.

178. In the same circle or in equal circles, if two arcs are equal, their chords are equal.

179. In the same circle or in equal circles, if two chords are equal, their subtended arcs are equal.

182. If a line passes through the center of a circle and is perpendicular to a chord, it bisects the chord and the arcs subtended by it.

183. In the same circle or in equal circles, if two chords are equal, they are equally distant from the center.

191. If a line is perpendicular to a radius at its outer extremity, it is tangent to the circle.

192. If a line is tangent to a circle, it is perpendicular to the radius drawn to the point of tangency.

193. If two tangents are drawn to a circle from an outside point, (1) the tangents are equal; (2) the line joining the outside point to the center bisects the angle between the tangents and the angle between the radii drawn to the points of contact.

201. If two circles intersect, the line of centers bisects their common chord at right angles.

202. If two circles are tangent externally or internally, the centers and the point of tangency are in a straight line.

211. A central angle is measured by its intercepted arc.

216. An inscribed angle is measured by one half the number of degrees in its intercepted arc.

217. An angle inscribed in a semicircle is a right angle.

224. If three points are not in the same straight line, one circle and only one can pass through them.

260. A line parallel to one side of a triangle and cutting the other two divides them into four corresponding segments which are proportional.

263. If a line parallel to one side of a triangle cuts the other two sides, the two sides are in proportion to their corresponding segments.

265. If a line divides two sides of a triangle into proportional corresponding segments, it is parallel to the third side.

269. Corresponding sides of similar polygons are in proportion.

270. If two triangles are mutually equiangular, they are similar.

271. A line cutting two sides of a triangle and parallel to the third side forms a second triangle similar to the first.

277. In two similar triangles any two homologous sides are proportional to (1) two corresponding altitudes; (2) two corresponding medians; (3) the bisectors of two corresponding angles.

282. If a perpendicular is drawn from the vertex of the right angle to the hypotenuse of a right triangle, (1) the two triangles formed are similar to each other and to the given triangle; (2) the perpendicular is a mean proportional between the segments of the hypotenuse; and (3) the square of either side about the right angle equals the product of the whole hypotenuse and the segment adjacent to that side.

284. In any right triangle the square of the hypotenuse equals the sum of the squares of the other two sides.

292. If from a point without a circle a secant terminating in the circle and a tangent be drawn, the square of the tangent equals the whole secant times its external segment.

312. The area of a rectangle is the product of its base and altitude.

319. The area of a parallelogram is the product of its base and altitude.

320. The area of a triangle is one half the product of its base and altitude.

322. The area of a trapezoid is one half the product of its altitude and the sum of its bases.

325. If two triangles have an angle of one equal to an angle of the other, their areas are to each other as the product of the sides including the angle of the first is to the product of the sides including the angle of the second.

326. The areas of two similar triangles are to each other as the squares of any two homologous sides.

327. The areas of two similar convex polygons are to each other as the squares of any two homologous sides.

359. The area of a regular polygon is one half the product of its perimeter and its apothem.

369. The area of the sector of a circle equals one half the product of its radius and its arc.

371. The area of a circle is πR^2 .

372. The areas of two circles are to each other as the squares of their radii.

373. The area of a sector is to the area of the circle as the angle of the sector is to four right angles.

CONSTRUCTIONS

232. Construct a triangle, given the three sides.

234. At a given point in a line construct a perpendicular to the line.

235. From a given point outside a line construct a perpendicular to the line.

SOLID GEOMETRY

BOOK VI

LINES AND PLANES

377. Introduction. Solid geometry is concerned with the properties and relations of figures which occupy space. This does not imply that the cubes, cylinders, and other bodies considered in this text are made of wood or other material substance, any more than that the squares and triangles of plane geometry are made of chalk or of the carbon from our pencils. In both cases the diagrams or solids which we construct are merely rough aids to our imagination, helping us to visualize the properties of the real figures, which are in every case objects of thought without material existence. Since, however, many of the objects around us very closely approximate the form of the purely geometric solids, the subject of solid geometry finds abundant application in the affairs of everyday life.

378. Assumptions. The assumptions of plane geometry fall into two classes, the axioms and the postulates. Axioms I–XII do not refer either to the plane or to space, but to relations between numbers, and will be assumed without discussion in what follows. The following assumptions of geometric content have been made in plane geometry.

Postulate I. *There is only one straight line through two points (§ 19).*

Postulate II. *Any geometric figure may be moved from one place to another without changing its size or shape (§ 20).*

Postulate V. Through a given point outside a line one line parallel to it exists, and only one (§ 45).

These postulates are assumed to hold in space.

Postulate I may also be restated as follows: Two points determine a straight line. One point does not determine a line, because more than one line passes through a fixed point. Nor do three points determine a line, because no line can be found which passes through any three points taken at random. The significance of the word *determine* in this statement is that there is one and only one line which contains the two points.

In several theorems of plane geometry, Postulate II is assumed to hold in space. For example, in proving that two triangles are congruent if three sides of one are equal respectively to three sides of the other (§ 33), the triangle may have to be lifted out of the plane and turned over in space, in order to make it take the desired position.

The word *move* in Postulate II does not imply that one can lift the figures of solid geometry, as one would lift stone blocks, and carry them from place to place. One cannot be expected to move in this sense anything that is merely an object of thought. To move a figure in geometry is to transfer our attention from a figure in one position to another figure exactly like it somewhere else. Hence congruent figures in space as well as in a plane may be considered as the same figure in different positions.

379. Definitions from plane geometry. The definitions given in plane geometry will be taken over to solid geometry without change. One must observe, however, that in solid geometry the emphasis in certain definitions is entirely redistributed. For example, parallel lines are defined (§ 43) as lines that lie in the same plane and do not meet however far they are produced. In the study of plane geometry it is never necessary to emphasize the clause "that lie in the same plane," because in every case the whole figure lies in one plane. But in solid geometry, where our figures lie anywhere in space, in proving two

lines parallel it is frequently more difficult to prove that they lie in the same plane than it is to show that they cannot meet however far they are produced.

QUERY 1. Are two horizontal lines necessarily parallel? Illustrate.

QUERY 2. Are two vertical lines necessarily parallel? Illustrate.

QUERY 3. Is every pair of lines in space either intersecting or parallel? Illustrate.

380. Undefined terms. It is assumed that the terms *figure*, *line*, *curve*, *surface*, and *solid* are familiar.

The word *line* will be used to denote a straight line extending indefinitely in both directions. To avoid ambiguity, the portion of a line between two of its points will often be called a *line-segment*.

381. The plane. A *plane* is a surface such that if any two points in it are taken, the straight line containing them lies wholly in the surface.

Since a line extends indefinitely in both directions, a plane is unlimited in extent. On account of the size of our page it is impossible to show the whole plane by a drawing. Hence it is customary to draw a parallelogram to represent a plane or that part of a plane with which we are particularly concerned. If it is desired to emphasize the fact that the plane extends farther in a certain direction, one side of the parallelogram may be replaced by a wavy line.

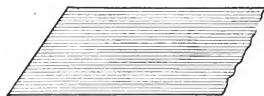

QUERY 4. What postulate is assumed in the definition of § 381.

QUERY 5. Show from the definition that two walls of a room do not form a single plane.

QUERY 6. Is the surface of a perfectly calm sea a plane?

QUERY 7. Do two points exist on the curved surface of a straight flag-pole such that the line passing through them lies entirely in the surface of the pole? If so, why is this surface not a plane?

QUERY 8. Does a plane have any edges?

382. Postulate VII. *Two intersecting lines lie in one and in only one plane.*

This postulate plays about the same rôle in solid geometry that Postulate I does in plane geometry.

QUERY 1. Can more than one plane pass through a given* line? Illustrate. Does one line determine a plane?

QUERY 2. Can you hold two pencils in such positions as to show that a plane cannot contain any two lines taken at random in space?

QUERY 3. Does a set of three concurrent lines necessarily determine a plane? Illustrate.

QUERY 4. Is a triangle necessarily a plane figure? Why?

Theorem 1

383. *Three points not on the same line lie in one and in only one plane.*

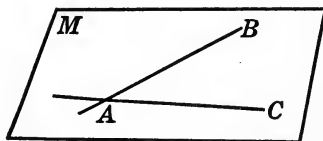

Given three points A , B , and C which do not lie on the same line.

To prove that A , B , and C lie in one and in only one plane.

Proof. Draw the lines AB and AC .

Denote by M the plane containing them both. § 382

A , B , and C lie in the plane M , since the lines containing them lie in that plane.

A , B , and C cannot lie in any other plane than M , since the lines containing them cannot lie in another plane. § 382

Hence A , B , and C lie in one and in only one plane.

* When a figure is referred to as "given," it is understood that the figure is supposed to be fixed both in size and in position. Thus, a given circle is one of definite size which is assumed to be fixed in position during the discussion. Of course, a line or a plane can be fixed only in position, since by definition they are indefinite in extent.

384. Corollary 1. *A line and a point not on the line lie in one and in only one plane.*

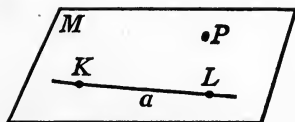

Given the line a and the point P not on a .

To prove that P and a lie in one and in only one plane.

Proof. Let K and L be any two points on a .

Denote by M the only plane containing P , K , and L . § 383

The line a must lie in M . § 381

Hence both a and P lie in M and in no other plane.

385. Corollary 2. *Two parallel lines lie in one and in only one plane.*

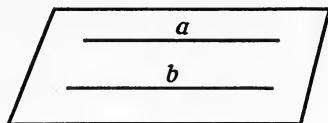

Given the parallel lines a and b .

To prove that a and b lie in one and in only one plane.

Proof. a and b lie in one plane. § 43

If they could lie in two planes at once, then one of them and any point of the other would lie in two planes at once, which is impossible. § 384

Hence a and b lie in one and in only one plane.

386. Restatement. The foregoing results may be stated as follows:

1. *Two intersecting lines determine a plane.*
2. *Three points not in the same line determine a plane.*
3. *A line and a point outside the line determine a plane.*
4. *Two parallel lines determine a plane.*

387. Perspective. In the diagrams of solid geometry the figure is usually supposed to be either to the right or the left of the eye of the observer or directly in front of and

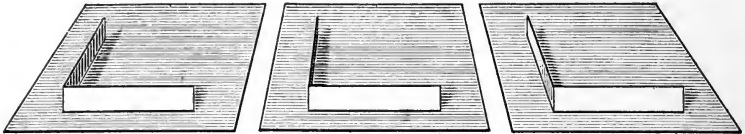

slightly below it. When a figure is drawn as it appears to the eye, it is said to be drawn in perspective.

QUERY 1. What is the position of the three preceding figures with respect to the eye of the observer?

QUERY 2. How would a horizontal plane look if the eye were just level with it?

QUERY 3. How does the shape of the top of a level table seem to change if you stand directly in front of it, a few feet away, first with the eye level with the top, and then rise to your full height? What difference do you observe if you repeat the process but do not stand directly in front of the table? Draw figures showing the different forms that the table top presents from your various positions.

388. Coplanar. Lines or points which lie in the same plane are said to be *coplanar*.

QUERY 4. Are two parallel lines necessarily coplanar?

QUERY 5. If three points are collinear, can more than one plane be found which will contain all of them? Illustrate. Do three collinear points determine a plane?

QUERY 6. Do any four points taken at random in space determine a plane? Illustrate.

QUERY 7. Why does a three-legged stool stand firmly on a level floor, while a four-legged one is likely to be unsteady?

QUERY 8. What does a moving line generate if it always passes through a given point and always intersects a given line?

QUERY 9. What does a moving line generate if it always intersects two intersecting lines?

EXERCISES

1. Any transversal of two parallel lines lies in the plane of those lines.

2. If a line cuts three concurrent lines at points other than their intersection, the four lines are coplanar.

3. If a plane contains one of two parallel lines and one point of the other, it must contain both of the parallels.

HINTS. Use §§ 385, 384.

389. Postulate VIII. *If two planes have one point in common, they must have at least two points in common.*

390. Intersection. The *intersection* of two lines, curves, or surfaces comprises those points, and only those, which they have in common.

Intersections of geometric figures fall into several classes, which are defined as follows:

If two intersecting lines, curves, or surfaces pass through each other, they are said to *cut each other*.

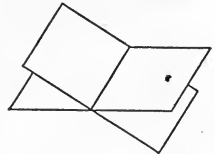

If one of two intersecting lines, curves, or surfaces is terminated at their intersection, it is said to *meet the other*.

If both of two figures terminate at their intersection, they are said to *meet each other*.

If a line either cuts or meets a plane, the intersection consists of only one point. If a line lies entirely in a plane, one frequently says that the plane passes through or contains the line.

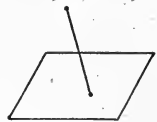

QUERY 1. Do the two sides of an angle cut each other?

QUERY 2. In the figure above is it correct to say that the line meets the plane or that the plane meets the line?

QUERY 3. Do the two planes above meet or cut each other?

QUERY 4. Hold two sheets of paper so that they meet each other.

Theorem 2

391. *If two planes intersect, their intersection is a straight line.*

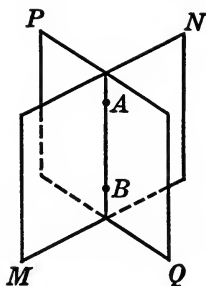

Given two planes MN and PQ which intersect.

To prove that their intersection is a straight line.

Proof. MN and PQ must have at least two points, as A and B , in common. § 389

Hence both MN and PQ contain the line AB determined by these points. § 381

But MN and PQ cannot have any point outside AB in common, else the planes would coincide. § 384

Therefore the intersection of MN and PQ is a straight line.

QUERY 1. Can you imagine two planes which do not have any points in common? Illustrate.

QUERY 2. How many planes can be passed, meeting a given plane in a given line? Illustrate.

QUERY 3. If three planes in space are taken at random, what is their intersection? Give an example.

QUERY 4. What is the least number of planes that can inclose a space? Give an example.

QUERY 5. What relations other than the one given in the answer to Query 3 may three planes bear to each other? Give examples.

QUERY 6. If two surfaces intersect in a straight line, is it necessary that both of them be planes? Give examples.

QUERY 7. Is the converse of Theorem 2 true?

PARALLEL LINES AND PLANES

392. Parallel planes. Two planes which do not meet however far they are produced are said to be *parallel*.*

Theorem 3

393. *If a plane intersects two parallel planes, the intersections are parallel lines.*

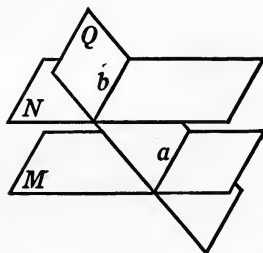

Given the plane M parallel to the plane N , and both cut by the plane Q , in lines a and b respectively.

To prove that a is \parallel to b .

Proof. a and b are straight lines. § 391

In order to prove $a \parallel$ to b , we must show, first, that they lie in the same plane; second, that they cannot meet.

Now a and b lie in Q . Given

Also, a and b cannot meet, since, if they did meet, the planes M and N would have a point in common, which is impossible. § 392

Therefore a is \parallel to b . § 43

QUERY 1. A point, a line, and a plane are given. What is the intersection of the plane with a moving line which contains the given point and cuts the given line? Mention any special cases that may occur.

* In this definition it is implied that if planes meet they are not parallel. A similar remark applies to most of the definitions in this and other texts.

QUERY 2. If two parallel planes are given, is it certain that there is a plane which intersects both of them? How many such planes are there? Are these planes necessarily parallel?

QUERY 3. Where is the figure of Theorem 3 situated with respect to the eye?

QUERY 4. Draw a figure for Theorem 3 which appears to be below and to the right of the eye.

394. Corollary. *Parallel line-segments intercepted between parallel planes are equal.*

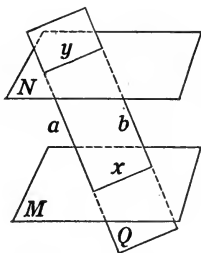

Given a and b , parallel line-segments intercepted between the planes M and N .

To prove that a is equal to b .

HINTS. Pass the plane determined by a and b intersecting M and N in x and y respectively.

Prove that a parallelogram is formed.

QUERY 5. Is a parallelogram necessarily a plane figure?

QUERY 6. Is every closed four-sided figure necessarily a plane figure? Illustrate.

QUERY 7. If two parallel planes cut off equal lengths on two lines, are the lines necessarily parallel? Illustrate.

QUERY 8. If two parallel planes cut off equal lengths on two lines, do the lines necessarily intersect if sufficiently produced? Illustrate.

EXERCISE 4. Given two parallel planes which cut off equal segments on two intersecting lines. Pass the plane of the intersecting lines and show that two isosceles triangles are formed.

395. Parallel lines and planes. A line and a plane that do not meet however far they are produced are said to be *parallel*.

QUERY 1. If a line is parallel to two planes, are the planes necessarily parallel to each other? Illustrate.

QUERY 2. If two planes are parallel, is a given line in one plane parallel to every line in the other? Is it parallel to some line in the other?

QUERY 3. How many lines are there through a given point parallel to a given plane? Illustrate.

QUERY 4. In what kind of surface do you think all the lines of Query 3 would lie?

QUERY 5. Hold a pointer so that it is parallel to a side and an end wall of the room. How many straight lines are there through a given point parallel to each of two intersecting planes?

Theorem 4

396. *If a plane contains only one of two parallel lines, it is parallel to the other line.*

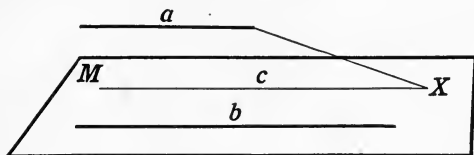

Given the line a parallel to the line b , and the plane M containing b but not containing a .

To prove that M is \parallel to a .

Proof. a meets M , if at all, in some point X which is not on b . Why?

Through X draw c in $M \parallel$ to b . § 43

Then we have through X two lines, a and c , both \parallel to b , which is impossible. § 45

Hence a cannot meet M and is \parallel to it. § 395

397. Constructions. For the present a construction in solid geometry means the building of a figure by application of the following actual or imagined operations:

1. The passing of planes (§§ 382, 383, 384, 385).
2. The determination of lines by the intersection of planes (§ 391).
3. The use of ruler and compasses in planes.

The third operation refers to the constructions of plane geometry performed in the planes afforded by the first process. Instead of having only one method of determining a line, as was the case in plane geometry, we now have two: a pair of points and a pair of nonparallel planes.

Construction 1

398. *Through a point outside a plane construct a line parallel to the plane.*

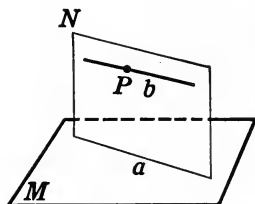

Given the point P outside the plane M .

Required to construct a line through $P \parallel$ to M .

Construction. Through the point P pass a plane N intersecting M in some line, as a .

In the plane N draw a line b through $P \parallel$ to a . § 45

Then b is \parallel to M .

Proof. b is \parallel to a . Const.

Therefore b is \parallel to M . § 396

Theorem 5

399. *If a line is parallel to a plane, the intersection of the plane with a plane passed through the line is parallel to the line.*

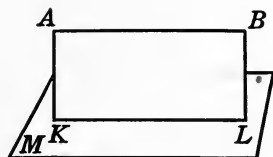

Given the line AB parallel to the plane M ; and the plane AL containing AB and intersecting M in KL .

To prove that AB is \parallel to KL .

Proof is left to the student.

QUERY 1. To how many lines in a given plane may a line be parallel?

QUERY 2. Under what conditions is a straight stick parallel to its own shadow on the ground?

QUERY 3. Under what conditions may a line be parallel to each of three planes? Illustrate.

QUERY 4. How many planes are there through a given point parallel to a given line? Illustrate.

EXERCISES

5. If a line and a plane are parallel, a line containing a point of the plane and parallel to the given line lies wholly in the plane.

HINTS. Let AB be parallel to M and let PR meet M in P and be parallel to AB . Pass a plane determined by AB and PR , meeting plane M in PQ . Show that PQ and PR are both \parallel to AB .

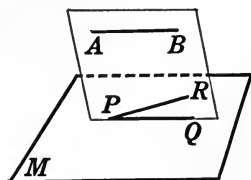

6. Through a given point construct a line parallel to a given plane and meeting a given line. Is this construction always possible?

7. Two intersecting planes are each parallel to a given line. What is the relation between the intersection of these planes and the line? Prove your statement.

HINT. Pass a plane determined by the given line and any point of the intersection of the planes.

Theorem 6

400. If two intersecting lines are parallel to a plane, their plane is parallel to the plane.

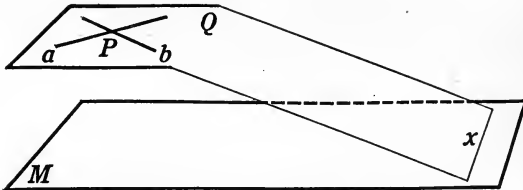

Given the lines a and b , both parallel to the plane M ; and Q , their plane.

To prove that

Q is \parallel to M .

Proof. If Q should intersect M in a line x , then a and b would each be \parallel to x . § 399

We should then have through the point P two lines, each \parallel to the same line, which is impossible. § 45

Therefore Q does not meet M , and is \parallel to it.

Why?

401. *Corollary.* If two intersecting lines are respectively parallel to, but not coplanar with, two other intersecting lines, the plane of the first pair is parallel to the plane of the second pair.

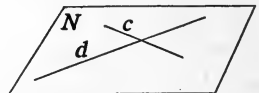
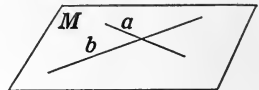

HINTS. Let N be determined by c and d . Then a and b are each \parallel to N by § 396.

Theorem 7

402. *If a plane intersects one of two parallel lines, it intersects the other also.*

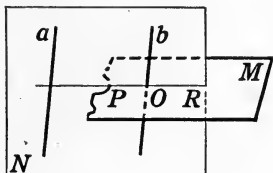

Given the line a parallel to the line b , and the plane M intersecting b at the point O .

To prove that M also intersects a .

Proof. Pass the plane N determined by a and b , intersecting M in RP . § 385

Then RP must intersect a . § 46

Hence M , the plane in which RP lies, must intersect a .

NOTE. It is always desirable to observe whether the reason for a given step is taken from plane geometry, and, if so, to note the plane containing the figure to which the reference is made. In the foregoing proof the figure to which § 46 applies lies in the plane of a and b .

403. Corollary 1. *If a line intersects one of two parallel planes, it intersects the other also.*

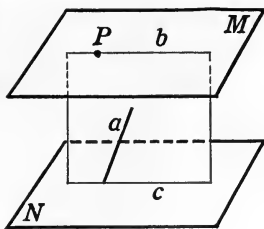

HINTS. Pass a plane determined by a and any point P of M . Apply § 46.

404. Corollary 2. *If a plane intersects one of two parallel planes, it intersects the other also.*

HINT. In the cutting plane draw a line cutting the line of intersection of the two planes.

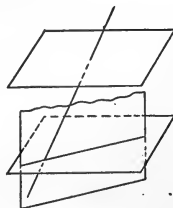

405. Corollary III. *If two planes are parallel to the same plane they are parallel to each other.*

HINT. Let M be \parallel to N and to P . If N should intersect P , show that it would also intersect M .

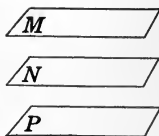

Theorem 8

406. *If two lines are parallel to the same line, they are parallel to each other.*

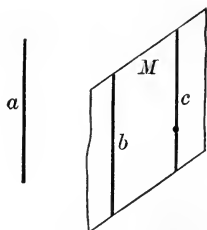

Given the lines b and c each parallel to a .

To prove b and c parallel to each other.

Proof. Pass the plane M containing b and one point of c . § 384

Now M either cuts c or contains it.

If M cuts c , it will cut a and b . § 402

But M cannot cut b for it contains b . Const.

Hence M cannot cut c . Therefore M contains c , since the only other possibility leads to a contradiction.

Therefore b and c lie in the same plane.

Since they are each \parallel to a , Given

b cannot meet c . § 45

Hence b is \parallel to c . § 43

NOTE. It should be observed that § 45 is assumed to be true in space as well as in a plane.

Theorem 9

407. *If two angles not in the same plane have their sides parallel and extending in the same direction from their vertices, they are equal.*

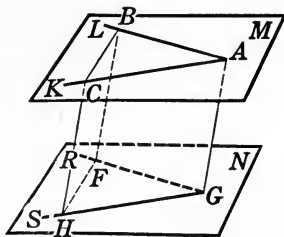

Given the angles LAK and RGS in the planes M and N respectively, with sides AL and AK parallel respectively to sides GR and GS .

To prove that $\angle LAK = \angle RGS$.

Proof. Construct $AB = GF$, and $AC = GH$, and draw AG , CH , and BF .

Now BG and CG are parallelograms. § 88

Hence BF and CH are each \parallel to AG . Why?

Consequently BF is \parallel to CH . § 406

Also $BF = CH$. Why?

Hence the figure $BCHF$ is a parallelogram, § 88

and $CB = HF$. Why?

In $\triangle BAC$ and FGH , $BA = FG$ and $AC = GH$, Const.

and we have proved $CB = HF$.

Therefore the \triangle are congruent, Why?

and $\angle BAC = \angle FGH$. Why?

QUERY 1. If the angles of Theorem 9 have their sides parallel each to each, but extend in opposite directions from their vertices, what is the relation between the angles?

Construction 2

408. *Through a point not in a plane, construct a plane parallel to that plane.*

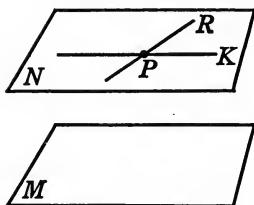

Given the point P and the plane M .

Required to construct a plane containing P and parallel to M .

Construction. Construct PR and $PK \parallel$ to M .

§ 398

Pass plane N determined by PR and PK .

Hence

N is \parallel to M .

Proof. Since PR and PK are each \parallel to M , N is \parallel to M . § 400

Theorem 10

409. *Through a point not lying in a plane, one and only one plane can be passed parallel to that plane.*

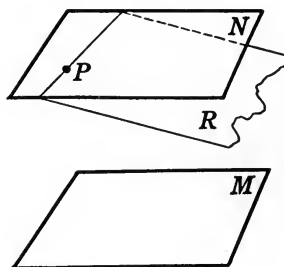

Given the point P and the plane M .

To prove that one and only one plane through P is \parallel to M .

Proof. Denote by N the plane constructed \parallel to M and containing P . § 408

Any plane through P other than N , such as R , would cut N . § 391

Therefore R would cut M , § 404

which is contrary to the hypothesis.

Hence N is the only plane through $P \parallel$ to M .

QUERY 1. How many planes are there parallel to two given parallel planes? Illustrate.

QUERY 2. How many planes are there through a given point parallel to two given parallel planes? Illustrate.

QUERY 3. Two lines are given. If a moving line is always parallel to one of the given lines and always intersects the other, what surface is generated and what is its position?

QUERY 4. In the statement "Through a given point outside a one parallel to it can be drawn, and only one," fill the blank spaces with the words *line* and *plane* in each of the four possible ways. Which of the resulting statements are true? In what section is each proved or assumed?

QUERY 5. If the angles of Theorem 9 have their sides parallel each to each, and if one pair extend in the same direction from the vertices while the other pair extend in opposite directions, what is the relation between the angles?

EXERCISES

8. If two lines are not in the same plane, one plane and only one can be passed containing one of these lines and parallel to the other.

9. Construct a line through a given point parallel to two given intersecting planes.

HINT. Pass the plane determined by the point and the intersection of the planes.

10. If one of two parallel lines is parallel to a plane, the other is also.

11. Through a given point one and only one plane can be passed parallel to two given nonparallel lines in space.

Theorem 11

410. *If two straight lines are cut by three parallel planes, the corresponding segments are proportional.*

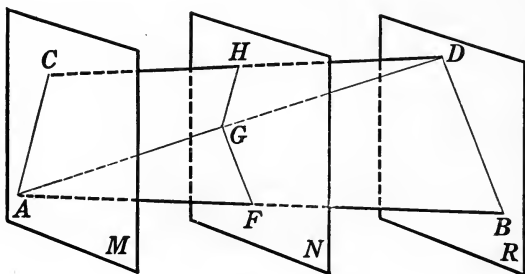

Given three parallel planes M, N, R , cutting two lines AB and CD in the points A, F, B and C, H, D respectively.

To prove that
$$\frac{AF}{FB} = \frac{CH}{HD}.$$

Proof. Draw AD ; pass the planes of DC and DA , and of AB and AD . Denote the intersections with the given planes by AC, GH, FG, BD .

AC is \parallel to GH , and FG is \parallel to BD . § 393

In $\triangle ADC$,
$$\frac{CH}{HD} = \frac{AG}{GD}.$$
 Why?

In $\triangle ABD$,
$$\frac{AF}{FB} = \frac{AG}{GD}.$$
 Why?

Therefore
$$\frac{AF}{FB} = \frac{CH}{HD}.$$
 Why?

411. Corollary. *If two parallel planes cut a series of concurrent lines, the corresponding segments are proportional.*

HINT. Pass the plane through the point common to the lines and parallel to one of the given planes (§ 409).

QUERY 1. In what case are F , G , and H of Theorem 11 in a straight line? Under what conditions are AC and BD parallel?

QUERY 2. Describe the positions of the planes that are drawn through a fixed point so as to contain a set of parallel coplanar lines; of parallel lines, not all coplanar; of concurrent coplanar lines; of concurrent lines, not all coplanar.

REVIEW EXERCISES

12. A quadrilateral is a plane figure if two of its sides are parallel.

13. If any number of parallel lines meet a given line, they are all coplanar.

14. If each of three lines meets the other two, the three are either coplanar or concurrent.

15. If two lines are not coplanar, show that it is impossible to draw two parallel lines each cutting both the given lines.

16. Given two lines which do not meet and are not parallel. Through a given point construct a third line meeting both the given lines. Discuss the special cases.

17. If the foot of a ten-foot pole is placed on the bottom of a body of water 8 feet deep, and the top of the pole is at the surface, will the middle of the pole always lie in the same plane? Prove your statement.

18. If a line in one of two intersecting planes is parallel to a line in the other, both lines are parallel to the intersection of the planes.

19. Given four lines in space, only two of which are parallel. Construct a line cutting all four lines. Discuss the special cases.

20. The top of a ten-foot pole is placed in the corner of a room at the ceiling. The foot of the pole is found to be on the floor 6 feet from the corner. How high is the room?

21. If three parallel planes cut off equal segments on one transversal, they cut off equal segments on every transversal.

22. In one of two parallel planes three lines are drawn which are parallel, each to each, to lines in the other plane. Are the triangles formed in the two planes necessarily similar? Prove your statement. Discuss special cases.

23. To which of the preceding theorems is the following statement equivalent? "If a line is parallel to a line in a plane, it is either parallel to or contained by the plane."

24. Construct a line parallel to a given plane and meeting each of two given lines. Discuss special cases.

25. Construct a line which cuts three given lines. Is more than one such line possible? Discuss special cases.

26. Through a given point pass two planes, one parallel to each of two given intersecting planes. What can you say of the intersection of the two planes so drawn? Prove your statement.

27. Construct a plane which shall pass through a given line and cut two given planes in parallel lines.

PERPENDICULAR LINES AND PLANES

412. Foot of a line. The point where a line intersects a plane is called the *foot* of the line.

QUERY 1. Can a line have two feet in a given plane and at the same time cut the plane?

QUERY 2. Are there any lines which have no foot in a given plane? Illustrate.

QUERY 3. At a given point in a line, how many perpendiculars to the line are there?

QUERY 4. How are the planes arranged which are determined by a given line and the various perpendiculars at a point on the line?

QUERY 5. If two lines are perpendicular to the same line, are they necessarily parallel? Illustrate.

QUERY 6. Keeping in mind that one must always provide a plane in space in which to perform a construction of plane geometry, how would you construct two lines perpendicular to a given line at the same point?

Theorem 12

413. *If a line is perpendicular to two lines at their point of intersection, it is perpendicular to any line in their plane through that point.*

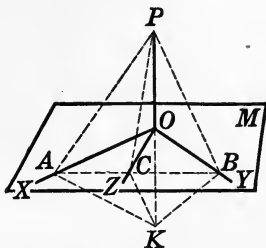

Given OX and OY , two lines in the plane M , each perpendicular to OP at O , and let OZ be any other line through O in M .

To prove that OP is \perp to OZ .

Proof. Draw any line in M not through O , cutting OX , OY , and OZ at A , B , and C respectively. Produce PO to K , making $OK = OP$. Draw lines PA , PB , PC , KA , KB , and KC .

In the plane determined by PK and OA , $PA = KA$. § 116

In the plane determined by PK and OB , $PB = KB$. Why?

Therefore $\triangle PAB$ and KAB are congruent. Why?

Hence $\angle PBC = \angle KBC$. Why?

Also $CB = CB$.

Therefore $\triangle PBC = \triangle KBC$. Why?

Consequently, $KC = PC$. § 27

Hence OZ contains two points, O and C , equidistant from P and K , and is therefore \perp to PK at O . § 118

Therefore OP is \perp to OZ .

414. Perpendicular to a plane. A line is *perpendicular* to a plane if it is perpendicular to every line in the plane drawn through its foot.

If a line intersects a plane and is not perpendicular to it, it is said to be *oblique* to the plane.

From this definition it appears that if a line makes an oblique angle with any line of a plane, it cannot be perpendicular to the plane. But one cannot show directly from the definition that a line is perpendicular to a plane without testing the angle which is found with *every* line through its foot, — a process which could never be completed, since it would require an infinite number of operations.

The great importance and power of Theorem 12 consists in two facts: first, it shows that a line can be perpendicular to all of the lines in a plane through its foot; second, it replaces the infinite number of operations mentioned above by only two, making it possible to show that a line is perpendicular to all lines in the plane drawn through its foot if it is found to be perpendicular to just two of them.

415. Corollary. *If a line is perpendicular to two lines at their point of intersection, it is perpendicular to their plane.*

This follows immediately from §§ 413, 414.

QUERY 1. If one line is perpendicular to another, is a plane containing the first line sure to be perpendicular to the second?

QUERY 2. How could you determine by use of a carpenter's square whether a square post is perpendicular to a level floor? How many operations are necessary?

QUERY 3. In the figure for Theorem 12, which point is nearer the eye, A or O ? B or O ? C or O ?

QUERY 4. Where is the triangle OAB with respect to the eye?

QUERY 5. Stand a pencil on end on a sheet of paper which lies on a level table. Draw several lines on the paper through the end of the pencil. Hold up a book so that one corner is between the eye and the point where the pencil meets the paper, and one edge of the book is in line with the pencil. In this way test which of the right angles formed should appear as right angles in a drawing.

QUERY 6. May a right angle ever be correctly represented by an obtuse angle? an acute angle? a straight angle? an angle of zero degrees? Explain.

QUERY 7. Can two pointers at right angles be held in such a position that the angle which they form appears to the class to be obtuse?

Construction 3

416. *Construct a plane containing a given point and perpendicular to a given line.*

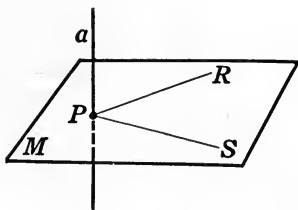

Given the point P and the line a .

Required to construct a plane containing P and \perp to a .

Case I. *When P is on the line a .*

Construction. At P construct two lines, PR and PS , each \perp to a . § 234

Pass the plane M determined by PR and PS . § 382

M is \perp to a at P .

Proof. a is \perp to PR and to PS . Const.

Therefore a is \perp to M . § 415

Case II. *When P is not on the line a .*

Construction. From P drop a \perp to a and denote the intersection by S . § 235

At S draw ST , another \perp to a . § 234

Pass the plane M determined by SP and ST . § 382

M is \perp to a .

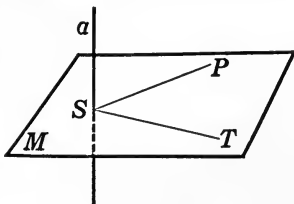

Proof is left to the student.

Theorem 13

417. *One and only one plane can be passed containing a given point and perpendicular to a given line.*

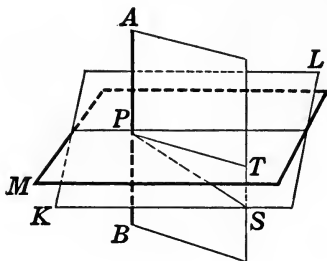

Given the point P and the line AB .

To prove that one and only one plane can be passed containing P and \perp to AB .

Case I. *When P is on AB .*

Proof. Denote by M a plane \perp to AB at P . § 416

Suppose there were another plane, as KL , also \perp to AB at P .

Let PT be any line in M through P .

Pass the plane AT determined by PT and AB , cutting KL in the line PS .

Then PT and PS are both \perp to AB at P . § 414

But PT and PS are both in the plane AT .

Therefore PT and PS must coincide. § 41

But PT is drawn as any line in M through P .

Hence M coincides with KL . § 382

Therefore only one plane can be \perp to AB at P .

QUERY. If a line a meets a plane M , to which it is not perpendicular, at a point P , does a line exist in M through P to which a is perpendicular? Does more than one such line exist?

Case II. When P is not on AB .

Proof. Denote by M a plane containing P and \perp to AB . Suppose there were another plane, N , containing P and also \perp to AB .

Now M and N could not both intersect AB at the same point. Case I

Let T and S be the intersections of M and N respectively with AB .

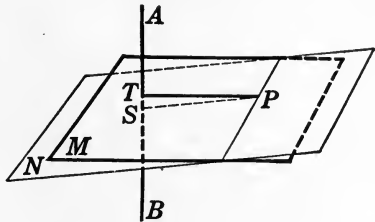

Then PT and PS are both in the plane determined by AB and P , and are both \perp to AB . § 414

Therefore PT and PS must coincide, § 42
and M coincides with N . Case I

Hence only one plane can be \perp to AB through P .

418. Corollary. All of the lines perpendicular to a line at a point lie in a plane perpendicular to that line at that point.

HINTS. Let BK and BR be any two \perp s to AB . Pass plane MN through BK and BR . Let BL be any other \perp to AB at B . Pass plane through BL and BK and show that the two planes coincide.

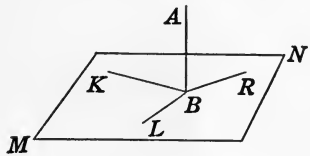

QUERY 1. In order to prove that the plane perpendicular to a line at a given point is the locus of lines perpendicular to the given line at that point, what two facts must be established? Are sections 414 and 418 sufficient for this purpose?

QUERY 2. If a right angle be rotated about one of its sides, what does the other side generate?

QUERY 3. What kind of surface does a spoke of a wheel, which is not dished, generate in its rotation?

QUERY 4. Can a plane always be passed parallel to one of two lines in space and perpendicular to another?

EXERCISE 28. If two planes are perpendicular to the same line, the planes are parallel.

Theorem 14

419. *If a line is perpendicular to one of two parallel planes, it is perpendicular to the other also.*

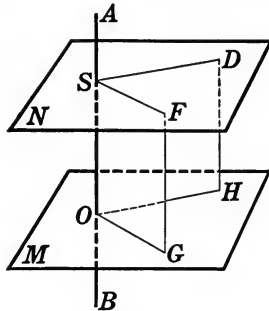

Given the parallel planes M and N and the line AB perpendicular to the plane M at the point O .

To prove that AB *is* \perp *to* N .

Proof. AB intersects N in some point S . § 403

Through the point S draw two lines in the plane N , as SD and SF .

Pass the planes SH and SG , determined by SD and AB , and by SF and AB respectively.

Let the intersections of these planes with M be called OH and OG respectively.

OG is \parallel to SF , and OH is \parallel to SD . § 393

But AB is \perp to OH and to OG . Why?

Hence AB is \perp to SD and to SF . § 47

Therefore AB is \perp to N . Why?

QUERY 1. Will a pointer held perpendicular to the floor of a room also be perpendicular to the ceiling?

QUERY 2. To how many planes is a given line perpendicular? Illustrate.

Construction 4

420. Construct a line perpendicular to a given plane and containing a given point.

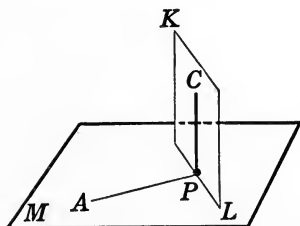

Given the point P and the plane M .

Required to construct a line containing P and \perp to M .

Case I. When P lies in M .

Construction. Draw any line PA in M through P , and pass the plane $KL \perp$ to PA at P . § 417

In KL draw $PC \perp$ to the intersection PL at P

PC is \perp to M .

Proof. PC is \perp to PL . Const.

PC is \perp to AP . § 414

Therefore PC is \perp to M . § 415

Case II. When P does not lie in M .

Construction. Construct the plane N containing P and \parallel to M . § 408

At P construct $PR \perp$ to N . Case I

Then PR is \perp to M .

Proof. PR is \perp to N . Const.

Therefore PR is \perp to M . § 419

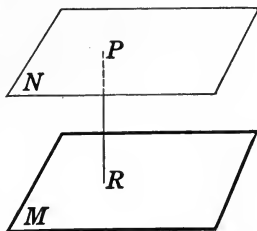

QUERY. Why could not Case II be proved as follows: "Draw any line in M , and drop a perpendicular from P to this line."

Theorem 15

421. *One and only one line can be drawn perpendicular to a given plane and containing a given point.*

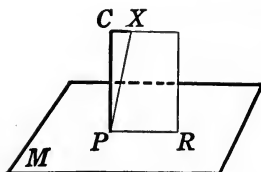

Given the plane M and the point P .

To prove that one and only one line can be drawn \perp to M and containing P .

Case I. *When P lies in M .*

HINTS. Denote by CP a line containing $P \perp$ to M (§ 420). If possible, let PX also be \perp to M at P . Pass the plane of CP and XP , and show that CP and XP coincide.

Case II. *When P does not lie in M .*

The proof, which is left to the student, may follow the hints for Case I, but referred to the adjacent figure.

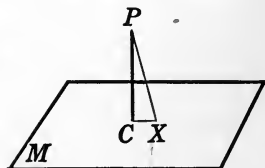

422. Corollary. *The perpendicular is the shortest line that can be drawn from a point to a plane.*

Given (see figure for Case II above) the plane M , and PC the perpendicular to M from P .

To prove that PC is the shortest line from P to the plane M .

Let PX be any other line from P to M .

In $\triangle PCX$, $\angle C$ is a right angle. § 414

Hence PC is shorter than PX . § 149

QUERY. Is the shortest distance from a point to a given line in a plane necessarily the shortest distance from the point to the plane?

Theorem 16

423. *The locus of points in space which are equidistant from two given points is the plane which bisects perpendicularly the line-segment joining the points.*

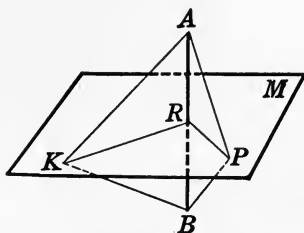

Given two points, A and B , and the plane M , which is perpendicular to the line AB at its middle point R .

To prove that M is the locus of points in space equidistant from A and B ; or (1) that every point in M is equidistant from A and B , and (2) that every point in space which is equidistant from A and B lies in M .

Proof. (1) Let P be any point in M . Draw PA , PB , and PR .

$\triangle PAR$ is congruent to $\triangle PBR$. Why?

Therefore $PA = PB$. Why?

(2) Let K be any point such that $KA = KB$. Draw KR .

$\triangle KAR$ is congruent to $\triangle KBR$. Why?

Therefore $\angle KRA = \angle KRB$, Why?

and KR is \perp to AB . § 37

Hence KR lies in the plane \perp to AB at R , § 418

and consequently K lies in that plane.

Therefore M is the locus of points in space equidistant from A and B .

QUERY 1. What is the locus of points which lie in a given plane and which are equidistant from two points not in that plane?

QUERY 2. What is the locus of points equidistant from three given points which are not in the same straight line?

QUERY 3. Determine a point in a given plane which is equidistant from three points in space. Discuss the various special cases.

424. Logical relation between propositions. If the hypothesis and the conclusion of a proposition are interchanged, the resulting proposition is called the *converse* of the original one. The relation between a proposition and its converse may be expressed in terms of symbols as follows:

(1) Direct proposition: If A is B , then C is D .

(2) Converse proposition: If C is D , then A is B .

If the negative of both the hypothesis and the conclusion is taken, the resulting proposition is called the *opposite* of the original. Using the same notation as above,

(3) Opposite proposition: If A is not B , then C is not D .

If a direct proposition and its converse are true, then the opposite proposition is true. Let us assume the truth of (1) and of (2) and prove that the truth of (3) follows. Now if A is not B , it follows that C is not D . For if C were D , then A would be B , by (2). But this contradicts the hypothesis of (3). Hence (3) is true.

In proving a locus theorem it is sufficient to prove a proposition and its converse (cf. § 423). In this text locus theorems are established by this method. From the preceding discussion it follows that another theorem, namely, the opposite, follows immediately from the proof of a theorem and its converse. For example, from Theorem 16 it follows that if a point is not in the plane which bisects the line-segment joining A and B , it is not equidistant from A and B .

QUERY 4. State the opposite of Theorem 5. Is it true?

QUERY 5. State the opposite of (a) § 413; (b) § 407; (c) § 400.

QUERY 6. Is the opposite of a true proposition necessarily true? Illustrate.

EXERCISE 29. Prove that if a proposition and its opposite are true, then the converse is true.

Theorem 17

425. (1) *If equal oblique line-segments are drawn from a point to a plane, they meet the plane at equal distances from the foot of the perpendicular to the plane from that point.* (2) *If oblique line-segments from a point to a plane meet the plane at equal distances from the foot of the perpendicular, the line-segments are equal.*

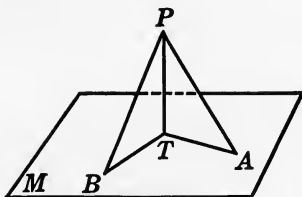

(1) **Given** PT perpendicular to the plane M , and PA equal to PB .

To prove that $TA = TB$.

HINT. Compare the $\triangle PTA$ and PTB .

(2) **Given** PT perpendicular to M , and TA equal to TB .

To prove that $PA = PB$.

Proof is left to the student.

QUERY 1. What is the locus of points in space equidistant from all the points of a given circle?

QUERY 2. What is the least number of rigid iron braces that will hold a pole in vertical position? What is the least number of guy ropes?

QUERY 3. The ceiling of a room is 10 feet high. How would you determine by means of a 12-foot pole and a pair of compasses a point in the floor directly under a given point in the ceiling?

QUERY 4. What is the logical relation of the proposition in § 425 (1) to that in (2)?

QUERY 5. State the opposite of § 425 (1). Is it true? Why?

QUERY 6. State the opposite of § 425 (2). Is it true? Why?

QUERY 7. What is the locus of the points in a plane a fixed distance from a given point not in the plane?

EXERCISES

30. If two oblique lines drawn from a point in a perpendicular to a plane cut off unequal distances from the foot of the perpendicular, the more remote is the greater.

31. Given a circle and a line perpendicular to its plane at its center. Prove that a line drawn to the circle from any point of the perpendicular is perpendicular to the tangent to the circle through its foot.

HINT. Draw any other line from the given point to the tangent and apply Exercise 30.

Theorem 18

426. *If one of two parallel lines is perpendicular to a plane, the other line is also perpendicular to the plane.*

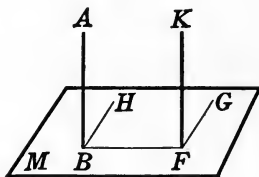

Given the line AB parallel to the line KF and perpendicular to the plane M .

To prove that KF is \perp to M .

Proof. KF intersects M . § 402

Draw FB , and any other line in M through F , as FG . Draw BH in $M \parallel$ to FG .

AB is \perp to BF . Why?

Hence KF is \perp to BF . § 47

It remains to prove $KF \perp$ to FG .

Now AB is \parallel to KF and BH is \parallel to FG . Why?

Hence $\angle ABH = \angle KFG$. § 407

But ABH is a right angle. Why?

Therefore KF is \perp to FG . Why?

Hence KF is \perp to M . Why?

QUERY 1. In the preceding proof why is it not sufficient to prove AB and KF both perpendicular to BF , and then to refer to § 44?

427. Corollary 1. *If two lines are perpendicular to the same plane, they are parallel.*

HINTS. Given a and $b \perp$ to M . Draw c through the foot of b and \parallel to a . Then c is \perp to M (§ 426). Therefore b and c coincide (§ 421).

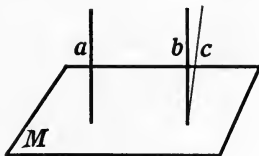

428. Distance to a plane. The *distance from a point to a plane* is the length of the perpendicular from that point to the plane.

By § 422 the distance from a point to a plane is the shortest distance from that point to the plane.

The *distance between two parallel planes* is the distance from a point of one to the other.

429. Corollary 2. *The distances to one of two parallel planes from any two points of the other are equal.*

QUERY 2. What is the locus of points a given distance from a given plane?

QUERY 3. What is the locus of points equidistant from two given parallel planes?

QUERY 4. How would you locate the points in a given plane which are 6 inches from another given plane? In what kind of figure would the points lie?

REVIEW EXERCISES

32. Two points on opposite sides of a plane and equally distant from it determine a line-segment which is bisected by the foot of the line.

33. Two points on the same side of a plane and equally distant from it determine a line that is parallel to the plane.

34. A plumb-line 6 feet long is suspended from the ceiling of a room 8 feet high. The lowest point of the line is 30 inches from a given point on the floor. What is the distance from this given point to the point in the floor, directly under the plumb-line?

35. A point is 16 inches from a given plane. What is the perimeter of the circle which contains the points of the plane which are 20 inches from the point.

36. A line parallel to a plane is everywhere equidistant from the plane.

37. Construct a line perpendicular to a given pair of parallel lines, which shall also meet a given third line. Is there any case in which the construction is impossible?

38. Every line perpendicular to a line which is given perpendicular to a given plane is parallel to the plane.

39. Let O denote the center of an equilateral triangle ABC whose side is a . At O a line-segment OP is drawn perpendicular to the plane of the triangle, so that the angle APB is a right angle. How long is OP ?

40. A point is 10 inches from a given plane. Lines 20 inches long are drawn from the point to the plane. What is the area of the circle on which the feet of these lines lie?

41. What is the locus of points in space equidistant from two parallel lines? Prove your statement correct.

42. What condition must be satisfied by two lines in order that it may be possible to construct a plane containing one of them and perpendicular to the other? Assuming that the condition is satisfied, perform the construction.

ANGLES BETWEEN PLANES

430. Dihedral angle. A *dihedral angle* is the figure formed by two planes which meet each other (§ 390).

QUERY 1. Can you hold your book so as to form a dihedral angle?

QUERY 2. How many dihedral angles are formed by the walls, ceiling, and floor of a square room?

431. Parts of a dihedral. The portions of the planes which form a dihedral angle are called the *faces* of the angle.

The intersection of the faces of a dihedral angle is called its *edge*.

A dihedral angle may be designated by its edge when there is no ambiguity. Thus, we may designate the adjacent figure as the dihedral AB . It may also be designated as $K-AB-R$.

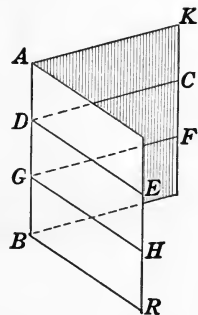

QUERY 3. Can two dihedral angles have one face in common? Illustrate with your book.

QUERY 4. Can more than one dihedral angle have the same edge?

432. Plane angle. The *plane angle* of a dihedral angle is formed by two lines, one in each face, each perpendicular to the edge at the same point.

In the above figure CDE and FGH each represent a plane angle of the dihedral AB .

EXERCISE 43. Any two plane angles of the same dihedral angle are equal to each other.

QUERY 5. Is the plane of ED and $DC \perp$ to AB ?

QUERY 6. Can angles other than plane angles be formed by two lines, one in each face of the dihedral angle and intersecting its edge at the same point? Illustrate.

QUERY 7. Can you find very small and also very large (nearly 180°) angles in illustrating Query 6?

QUERY 8. What relations do the planes of the plane angles of a dihedral angle bear to the edge of the dihedral?

Theorem 19

433. If two dihedral angles are congruent, their plane angles are equal.

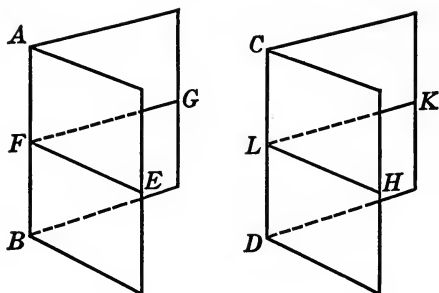

Given the congruent dihedrals AB and CD and their plane angles GFE and KLH respectively.

To prove that $\angle GFE = \angle KLH$.

Proof. Since the dihedrals are congruent, we may consider them as different positions of the same figure. § 378

Hence, if they are brought into coincidence so that the points F and L coincide, FE will coincide with LH and FG with LK . § 41

Therefore $\sphericalangle EFG$ and HLK coincide and are equal.

Theorem 20

434. Two dihedral angles are congruent if their plane angles are equal.

Given (see figure for Theorem 19) the dihedrals AB and CD , having equal plane angles GFE and KLH .

To prove that the dihedral angles AB and CD are congruent.

Proof. Bring the equal plane \sphericalangle into coincidence. § 20

Then the plane of GFE will coincide with that of KLH . Why?

The edge AB is \perp to the plane of GFE at F , and the edge CD is \perp to the plane of KLH at L . § 415

Then the edge AB coincides with the edge CD , § 421

and the faces AG and CK , and AE and CH , coincide. § 382

Therefore the dihedrals AB and CD are congruent. Why?

QUERY 1. Following the analogy of the definition of vertical angles in plane geometry, can you give a definition of vertical dihedral angles?

QUERY 2. Why are vertical dihedrals equal?

QUERY 3. If two parallel planes are cut by a third plane, how would you pass a plane which would determine the plane angles of all eight dihedrals of the figure?

QUERY 4. Can you state several theorems giving relations between the dihedral angles formed when two parallel planes are cut by a third plane?

435. Perpendicular planes. Two planes are *perpendicular* to each other if they form a dihedral angle whose plane angle is a right angle.

436. Right dihedral. A dihedral angle whose plane angle is a right angle is called a *right dihedral angle*.

NOTE. If two equal dihedral angles are placed adjacent to each other, doubling of the dihedral angle also doubles the plane angle. In general two plane angles are in the same proportion as their corresponding dihedrals.

EXERCISES

44. Following the analogy of the corresponding definitions of plane geometry, define the following kinds of dihedral angles: acute, obtuse, adjacent, supplementary, complementary.

45. Construct a dihedral angle having a plane angle of (a) 90° , (b) 45° , (c) 60° .

46. Construct a right dihedral with a given line as edge and a given plane containing that line as face.

47. If two planes cut and are perpendicular to each other, the four dihedrals formed are all right dihedrals.

Theorem 21

437. *If a line is perpendicular to a plane, every plane containing the line is perpendicular to the plane.*

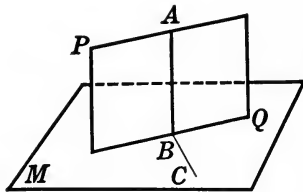

Given the line AB perpendicular to the plane M , and PQ any plane containing AB .

To prove that PQ is \perp to M .

Proof. In M draw $BC \perp$ to the edge BQ at B .

Then AB is \perp to BQ and to BC . Why?

But ABC is the plane \angle of the dihedral $A-BQ-C$. Why?

Therefore PQ is \perp to M . § 435

438. **Corollary.** *If a line is perpendicular to a plane, every plane parallel to the line is perpendicular to the plane.*

HINT. Apply §§ 399, 426, and 437.

QUERY 1. In Theorem 21 would it have been correct to draw BC in M perpendicular to AB and to BQ ?

QUERY 2. If a line is parallel to one plane and at the same time perpendicular to another, what relation must the planes bear to each other? Illustrate.

QUERY 3. In the figure above what is the plane angle of the dihedral formed by PQ and the plane of AB and BC ?

QUERY 4. How many planes are there which contain a given perpendicular to a plane?

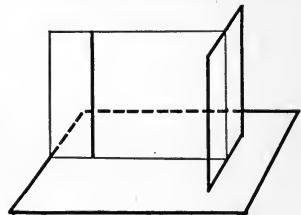

EXERCISES

48. If a plane is perpendicular to the intersection of two planes, it is perpendicular to each of the planes.

49. If three lines are perpendicular to each other at a common point, what is the relation to one another of the three planes determined by the three pairs of lines? Prove your statement.

Theorem 22

439. *If two planes are perpendicular to each other, a line drawn in one perpendicular to their intersection is perpendicular to the other.*

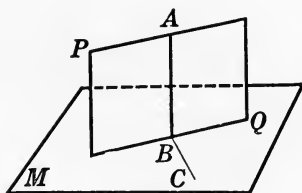

Given the plane PQ perpendicular to the plane M , and the line AB in PQ perpendicular to the intersection BQ .

To prove that AB is \perp to M .

Proof. Draw BC in $M \perp$ to BQ at B .

Then ABC is the plane \angle of dihedral $A-BQ-C$. Why?

Hence ABC is a right \angle . § 436

Therefore AB is \perp to M . Why?

QUERY 1. If two planes are perpendicular to each other, any line perpendicular to one of them is how related to the other?

QUERY 2. What condition must be fulfilled in order that there may be a plane perpendicular at the same time to a given plane and to a given line?

EXERCISES

50. If a line and a plane are both perpendicular to the same plane, they are parallel. (Assume that the line does not lie in the first plane. See Theorem 21.)

51. Construct a plane which contains a given point, is parallel to a given line, and is perpendicular to a given plane.

Theorem 23

440. *If two planes are perpendicular to each other, a line drawn from any point in one, perpendicular to the other, lies in the first.*

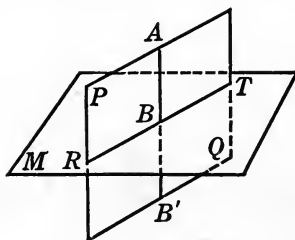

Given the plane PQ perpendicular to the plane M , and the point A in PQ , from which a line AB is drawn perpendicular to M .

To prove that AB *lies in* PQ .

Proof. From A draw AB' in $PQ \perp$ to the intersection RT .

Then AB' is \perp to M . § 439

Then AB and AB' are the same line. § 421

Hence AB lies in PQ , since it coincides with AB' , which was constructed in PQ .

EXERCISE 52. Construct a figure and devise a proof of Theorem 23 for the case where the point A is in the intersection, RT , of the plane PQ and M .

Theorem 24

441. *If two intersecting planes are perpendicular to a third plane, their line of intersection is perpendicular to that plane.*

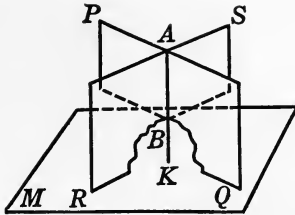

Given the planes PQ and RS , each perpendicular to M , and AB , their intersection.

To prove that AB is \perp to M .

Proof. From A , a point of AB , drop a \perp AK to M .

Then AK lies in PQ and also in RS . § 440

Hence it is their intersection and coincides with AB . § 391

Consequently AB is \perp to M , since it coincides with the line AK , which is drawn \perp to M .

QUERY. A plane revolves about a fixed line which lies in it (as the lid of a chest revolves about the line of its hinges). Find a plane to which the revolving plane is always perpendicular. How many such planes are there?

442. Bisector of a dihedral angle. A plane is said to *bisect* a dihedral angle if it contains the edge of the dihedral angle, and if the dihedral angles which it forms with the faces are equal.

EXERCISES

53. Construct a plane bisecting a given dihedral angle.

54. If one plane meets another, forming two adjacent dihedral angles, the planes which bisect these angles are perpendicular to each other.

Theorem 25

443. *The bisector of a dihedral angle is the locus of points equidistant from the faces of the dihedral.*

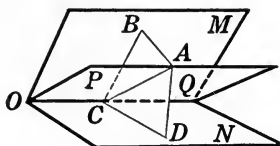

Given the dihedral $M-QO-N$, and the plane PQ bisecting this dihedral.

To prove (1) *that every point in* PQ *is equidistant from* M *and* N ;

(2) *that every point equidistant from* M *and* N *lies in* PQ .

Proof. (1) Let A be any point in PQ .

Draw AB and $AD \perp$ to M and to N respectively.

Pass the plane determined by AB and AD , cutting M, PQ , and N in BC, AC , and CD respectively.

The plane $ABCD$ is \perp to M and to N . § 437

Hence OC is \perp to plane $ABCD$. § 441

Therefore OC is \perp to CB, CA , and CD . Why?

Therefore ACB and ACD are the plane angles of their respective dihedrals. § 432

Hence $\angle ACB = \angle ACD$. § 433

Therefore $\triangle ABC$ is congruent to $\triangle DCA$. § 50

Hence $AB = AD$. Why?

(2) Let A be any point such that the $\perp AD$ and AB are equal. Pass the plane PQ determined by A and OQ .

Also pass the plane determined by AB and AD , cutting M , PQ , and N in BC , AC , and CD respectively.

$\triangle ABC$ is congruent to $\triangle ACD$. Why?

Therefore $\angle ACD = \angle ACB$. Why?

But these angles may be proved to be the plane angles of their respective dihedrals by the same method as that used earlier in this demonstration.

Hence dihedrals $A-CQ-B$ and $A-CQ-D$ are equal, § 434
and PQ bisects $M-QO-N$. § 442

Hence A lies in the bisecting plane.

Theorem 26

444. *If a line is not perpendicular to a plane, one and only one plane can be passed containing the line and perpendicular to the plane.*

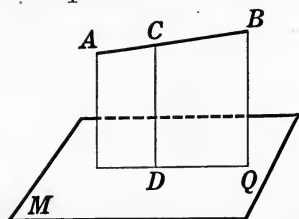

Given the line AB , not perpendicular to the plane M .

To prove that one and only one plane can be passed containing AB and \perp to M .

Proof. From any point C of AB draw $CD \perp$ to M , and pass the plane AQ determined by AB and CD .

AQ is \perp to M . § 437

Any other plane through $AB \perp$ to M would contain CD , § 440
and hence would coincide with AQ . § 382

Therefore one and only one plane can be passed, containing AB and \perp to M .

QUERY 1. If two planes cut each other, forming four dihedrals, what is the locus of points equidistant from the faces of these dihedrals?

QUERY 2. How can you find a point in a given line equidistant from the faces of a given dihedral? Discuss any special cases.

QUERY 3. What is the locus of points in a given plane equidistant from the faces of a dihedral angle? Discuss any special cases.

QUERY 4. What is the locus of points equidistant from the faces of a dihedral and also equidistant from two given points?

QUERY 5. What is the locus of points equidistant from the faces of a dihedral angle and also equidistant from three given points?

QUERY 6. How would you find the locus of points 4 inches from each of the faces of a given dihedral?

QUERY 7. What is the locus of points equidistant from two parallel planes and also equidistant from the faces of a given dihedral?

EXERCISES

55. If three or more planes intersect in a common line, the lines perpendicular to them from any given external point are coplanar.

56. If from any point within a dihedral angle lines are drawn perpendicular to the faces, the angle between these lines is the supplement of the plane angle of the dihedral.

57. All the perpendiculars to a plane erected from points of a line in that plane lie in a plane perpendicular to the given plane.

58. Draw a figure and devise a proof of Theorem 26 for the case where AB lies in M .

59. A line is perpendicular to the bisector of a dihedral at the point C and intersects the faces of the dihedral at A and B . Show that AB is bisected at C .

60. If the bisecting planes of two adjacent dihedrals are perpendicular to each other, the exterior faces of the adjacent angles form one plane.

61. Through a point O of the edge of a dihedral angle a line OA is drawn in one of the faces. Construct in the other face a line OB such that the angle AOB will be a right angle.

PROJECTIONS

445. Projection of a point. The *projection of a point* on a plane is the foot of the perpendicular from the point to the plane.

The perpendicular which contains the point and its projection is called the *projecting line* of the point.

QUERY 1. Does a given point have more than one projection on a given plane?

QUERY 2. Under what conditions may two points have the same projection on a given plane?

QUERY 3. If two points are projected on the same plane, what is the relation between their projecting lines?

QUERY 4. If a point is projected on two planes, how must the planes be situated in order that the projecting lines may be identical?

446. Projection of a line. The *projection of a line* (or of a curve) on a given plane is the locus of the projections of its points on that plane.

The plane containing a given line, and perpendicular to a given plane (§ 444), is called the *projecting plane* of the line on the given plane.

P is the projecting plane of the line a on the plane M .

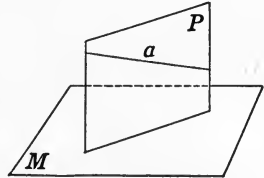

QUERY 5. Can a complete line have a line-segment for its projection? Illustrate.

QUERY 6. What is the projection on a plane of a line perpendicular to it?

QUERY 7. In what part of the heavens is the sun if the shadow of a line is its projection on the ground?

QUERY 8. Between what limits may the length of the projection of a given line-segment vary? Illustrate.

QUERY 9. Under what conditions is the projection of a circle an equal circle? a line-segment?

QUERY 10. Under what conditions does the projection of a plane figure form a straight line?

Theorem 27

447. *If a line is not perpendicular to a given plane, its projection on that plane is the intersection of its projecting plane with the given plane.*

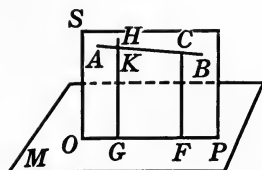

Given the plane M , the line AB not perpendicular to M , and the projecting plane SP , which intersects M in OP .

To prove (1) *that every point of* AB *has its projection in* OP ;
 (2) *that every point of* OP *is the projection of some point of* AB .

Proof. (1) Let C be any point of AB , and let F be the foot of the \perp from C to M .

F is the projection of C on M . § 445

CF lies in SP . § 440

Therefore F is in OP , the intersection of M and SP . § 390

(2) Let G be any point of OP . Draw $GH \perp$ to M .

Then GH lies in SP . § 440

Hence GH must either cut AB or be \parallel to it.

If they were \parallel , AB would be \perp to M , § 426

which contradicts the hypothesis.

Therefore GH cuts AB in some point K .

Hence G is the projection of K . § 445

QUERY 1. Which of the two parts of the proof given in § 447 would it be possible to carry out in an attempt to show that the projection of a circle whose plane is perpendicular to the given plane is a complete line?

QUERY 2. Is the projection of a corkscrew on a plane ever straight?

QUERY 3. By holding a right angle in various positions, what angles may be obtained as its projection on a given plane?

QUERY 4. In what case does a rectangle project into a rectangle?

QUERY 5. Is the following statement correct? "A plane is determined by a line and its projection on a given plane." Illustrate.

EXERCISES

62. Construct the projection of a given line-segment upon a given plane.

63. If a line-segment is parallel to a plane, it is parallel and equal to its projection on the plane.

64. The projection of a square upon a plane which is parallel to that of the square is a congruent square.

Theorem 28

448. *The acute angle which a line makes with its projection on a plane is the least angle which it makes with any line drawn in the plane through its foot.*

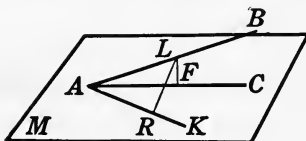

Given the line AB , and AC its projection on the plane M . Let AK be any other line in M through the point A .

To prove that $\angle BAC < \angle BAK$.

Proof. From L , any point on AB , draw the projecting line LF , and draw LR , making $AR = AF$.

In $\triangle LAF$ and LAR ,

$$AL = AL \text{ and } AF = AR.$$

Why?

But

$$LF < LR.$$

§ 422

Therefore

$$\angle LAF < \angle LAR.$$

§ 151

449. Angle between a line and a plane. The angle which a line makes with a plane is the acute angle which it makes with its projection on that plane.

QUERY. If a line is oblique to a plane, what is the greatest angle that it makes with any line drawn through its foot in the plane?

EXERCISES

65. A line makes equal angles with two parallel planes.

66. Two parallel lines make equal angles with any plane.

67. The projections of two equal and parallel line-segments on a plane are equal.

68. Equal line-segments from a given external point to a given plane are equally inclined to the plane.

69. What is the length of the projection of a line-segment 6 inches long on a plane to which it is inclined at an angle of (a) 45° ? (b) 60° ?

70. Two lines intersect at an angle of 60° , and each makes an angle of 45° with a plane M . Prove that the projections of the two lines on M are perpendicular to each other.

450. Projection of areas. In section 287 it was shown that if a line-segment AB makes an angle x with the line AR , then the projection of AB on AR is

$$AC = AB \cdot \cos x.$$

If two planes make an angle x with each other, an inspection of the adjacent figure shows that if AC denotes the projection of AB on M

$$AC = AB \cdot \cos x.$$

If now a rectangle whose base and altitude are denoted by a and b respectively is placed so that the base a is the line of intersection of the plane of the rectangle with a plane with which it

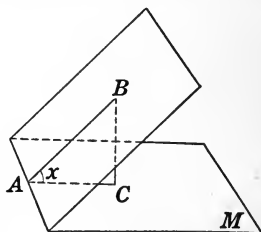
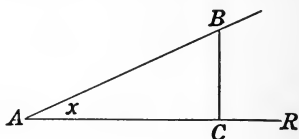

makes an angle x , then the projection of the rectangle is another rectangle whose base is a and whose altitude is $b \cos x$. Hence the area of the projection of the original rectangle is $ab \cos x$; that is,

$$\text{area } PR = ab \cos x = \text{area } PQ \cdot \cos x.$$

Since any plane figure can be divided, either exactly or approximately, into rectangles, it can be proved that *the area of the projection of any plane figure on a plane making an angle x with the plane of the original figure equals the area of the original figure multiplied by the cosine of the angle between the planes.*

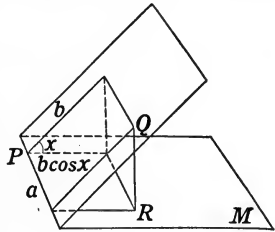

If the plane of a circle O of radius r makes an angle x with another plane, the projection of the circle on that plane is a closed curve E which is shorter one way than it is the other. This curve is called an *ellipse*. Evidently AB , the longest axis of the ellipse, equals the diameter of the circle, while the shortest axis, CD , is the projection of the diameter of the circle. Thus $AM = RL = r$, while $CM = r \cdot \cos x$.

If the projection of the radius on P is called b , then

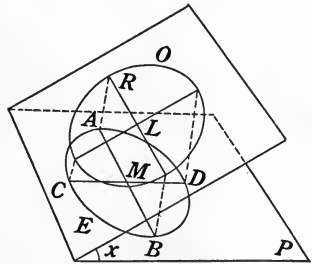

$$\begin{aligned} \text{area of ellipse} &= \text{area of projection of circle} = (\text{area of circle}) \cdot \cos x \\ &= \pi r^2 \cdot \cos x = \pi r(r \cos x) = \pi r b. \end{aligned}$$

It is customary to denote the longer (major) axis of the ellipse by $2a$ and the shorter (minor) axis by $2b$. Then the area of the ellipse is represented by πab .

EXERCISES

71. The roof of a house slants at an angle of 45° . When the sun is directly overhead, what area on the floor is struck by the sun through a window in the roof 5 feet by 7 feet?

72. What angle does one plane make with another if the figures of one of them are projected on the other into figures of half the area of the original figures?

73. Find the area of an ellipse whose axes are 5 and 9 inches respectively.

74. A circle of radius 10 inches lies in a plane which makes an angle of 60° with a second plane. What is the area of the projection of the circle on the second plane?

75. If the projection of a circle of diameter 24 inches is an ellipse whose axes are 24 and 16 respectively, find the angle which the plane of the circle makes with the plane of the ellipse.

QUERY 1. Keeping in mind the preceding discussion of projections, what reason can you assign for the fact that it is hotter in summer than it is in winter?

SKEW LINES

451. **Skew lines.** Two nonintersecting and nonparallel lines in space are called *skew lines*.

QUERY 2. Among the lines meeting two skew lines is it possible to find a pair which (1) intersect, (2) are parallel?

452. **Skew quadrilateral.** The figure formed by the line-segments joining four noncoplanar points in order is called a *skew quadrilateral*.

If a quadrilateral is cut from a sheet of paper and folded along a diagonal, the properties of the skew quadrilateral may easily be visualized.

QUERY 3. Can two sides of a skew quadrilateral be parallel?

QUERY 4. Do the diagonals of a skew quadrilateral intersect?

QUERY 5. Can a skew quadrilateral have four right angles?

QUERY 6. Explain how a skew quadrilateral may have four equal sides, two opposite right angles, and the other two angles acute.

QUERY 7. What is the locus of points viewed from which a skew quadrilateral looks like a plane angle?

Construction 5

453. *To construct a line perpendicular to two skew lines.*

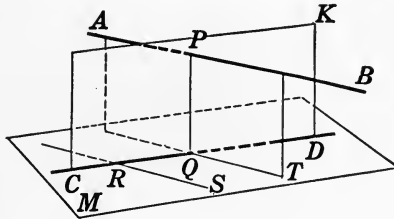

Given the skew lines AB and CD .

Required to construct a line perpendicular to both AB and CD .

Construction. Through R , any point of CD , draw a line $RS \parallel$ to AB , and pass the plane M determined by CD and RS .

The plane M is \parallel to AB . § 396

Pass a plane CK , containing CD and \perp to M , intersecting AB at the point P . § 444

In CK , from the point P , draw

$PQ \perp$ to CD . § 235

Then PQ is also \perp to AB .

Proof. Through PQ and AB pass a plane meeting M in QT .

Then QT is \parallel to AB . § 399

But PQ is \perp to M . § 439

Hence PQ is \perp to QT . Why?

Therefore PQ is \perp to AB . § 47

454. Corollary. *The common perpendicular of two skew lines is the shortest line that connects them.*

HINTS. Let PQ be the common \perp , and let KR be any other line connecting AB and CD . Let M contain CD and be \parallel to AB . Draw $RT \perp$ to M . Then $PQ = RT$. Prove $RT < RK$.

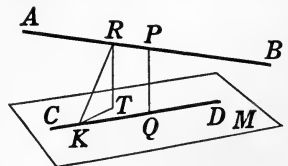

REVIEW EXERCISES

76. Construct two parallel planes, each containing one of two given skew lines.

77. If a plane is perpendicular to the edge of a dihedral angle, it is perpendicular to each of the faces.

78. If one of two planes is parallel to a given line, but the other is not, the planes must intersect.

79. If three equal line-segments which do not all lie in the same plane are each perpendicular to a plane, their other extremities determine a plane parallel to that plane.

80. The projections of two parallel lines upon a plane are either two parallel lines or one line or two points.

81. If one side of a right angle is parallel to a plane, the projection of the right angle upon the plane is a right angle or a straight line.

82. If one side of a square is parallel to a plane, the projection of the square on the plane is a rectangle or a line-segment.

83. In sawing off a square timber with a handsaw it is comparatively easy to keep the blade of the saw perpendicular to one of the edges of the timber. If this is done, prove that the stick is sawed off square.

84. Given a room 12 feet high, what is the locus of a point on a 15-foot pole 5 feet from one end if the extremities of the pole are respectively in the floor and the ceiling of the room?

85. If two parallel lines meet two parallel planes, the four angles which the lines make with the planes are equal.

86. If two planes are perpendicular to two perpendicular lines, each to each, the planes form a right dihedral angle.

87. If a quadrilateral has four right angles, it lies in a plane.

88. Through a given point construct a plane making equal angles with two given intersecting planes.

89. If two lines in one of two intersecting planes make equal angles with the intersection, they make equal angles with the other plane.

90. The sides of any plane angle are equally inclined to any plane through its bisector.

91. If two planes are not perpendicular, the projection on one of any parallelogram lying in the other is a parallelogram.

92. One side of a square lies in a plane with which the plane of the square makes an angle of 60° . If a side of the square is 8 inches, what is the area of its projection?

93. One side of an equilateral triangle lies in a plane with which the plane of the triangle makes an angle of 30° . If each side of the triangle is 10 inches, what is the area of its projection?

BOOK VII

POLYHEDRONS, CONES, AND CYLINDERS

455. Polyhedron. A solid bounded by polygons is called a *polyhedron*.

The bounding polygons are called the *faces*, their lines of intersection are called the *edges*, and the intersections of the edges are called the *vertices* of the polyhedron.

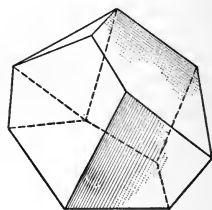

456. Convex polyhedrons. A polyhedron which lies entirely on one side of the planes of each of its faces is called a *convex polyhedron*.

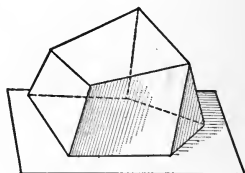

Unless the contrary is stated, it will be assumed that all of the polyhedrons treated in this book are convex.

457. Plane sections. The intersection of a solid and a plane is called a *plane section* of the solid. The plane sections of convex polyhedrons are convex polygons. A plane section which has a circle as a perimeter is called a *circular section*.

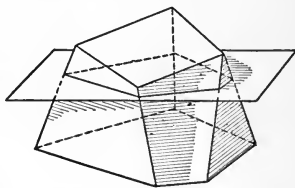

458. Prism. A *prism* is a polyhedron two of whose faces are polygons which lie in parallel planes, and whose other faces are parallelograms which intersect in parallel lines.

The faces which lie in the parallel planes are called the *bases* of the prism. The parallelograms included between the bases are called the *lateral faces*. The intersections of the lateral faces are called the *lateral edges*. The sum of the areas of the lateral faces is called the *lateral area* of the prism. The perpendicular distance between the bases is called the *altitude* of the prism.

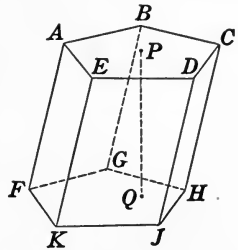

In the adjacent figure, AC and FH are the bases, AF, BG , etc. are the lateral edges, AG, BH , etc. are the faces, and PQ is the altitude.

QUERY 1. Why is each side of the upper base of a prism necessarily parallel to a side of the lower base?

QUERY 2. In the adjacent figure all of the faces are parallelograms, and the faces A and B lie in parallel planes. Why is it not a prism?

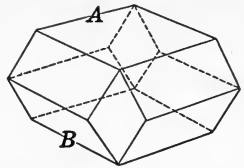

QUERY 3. What is the least number of faces that a polyhedron can have? edges? vertices?

QUERY 4. Is there any greatest number of faces that a polyhedron can have?

QUERY 5. If the lateral edges of a prism make a very small angle with a base, what is the relation between the length of the altitude and that of a lateral edge?

QUERY 6. Why must the upper and the lower base of a prism have the same number of sides?

QUERY 7. If two prisms have equal lateral edges, are their altitudes necessarily equal?

QUERY 8. Can a plane section of a prism be a trapezoid?

EXERCISES

1. Any lateral face of a prism is parallel to each of the lateral edges which it does not contain.

2. The section of a prism made by a plane cutting the prism and parallel to one of the lateral edges is a parallelogram.

Theorem 1

459. *The sections of a prism by two parallel planes, each cutting all of the lateral edges, are congruent polygons.*

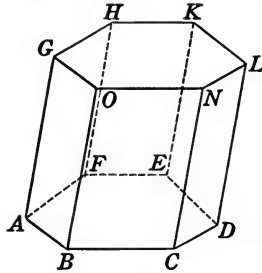

Given any prism cut by parallel planes $G-L$ and $A-D$, forming the sections $ABCDEF$ and $GONLKH$.

To prove that these polygons are congruent, that is, that their corresponding sides and angles are equal.

Proof.	AB is \parallel to GO , BC is \parallel to ON , etc.	§ 83
Hence	$\angle ABC = \angle GON$, etc.	§ 407
Furthermore	$AB = GO$, $BC = ON$, etc.	§ 85
Therefore	$ABCDEF$ is congruent to $GHLKNO$.	§ 24

460. **Right section.** If a plane cutting all the edges of a prism is perpendicular to one of them, the section formed is called a *right section*.

461. **Right prism.** A *right prism* is one whose base is a right section of the prism.

If a prism is not a right prism, it is said to be *oblique*.

Prisms whose bases are triangles, quadrilaterals, or hexagons are called triangular, quadrangular, or hexagonal prisms.

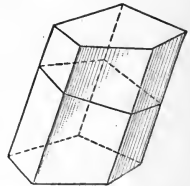

462. Regular prism. A right prism whose base is a regular polygon is called a *regular prism*.

Prove each of the following properties of a prism :

463. *The bases of a prism are congruent polygons.*

464. *All sections of a prism parallel to the base are congruent.*

465. *The lateral edges of a prism are equal and parallel.*

466. *A right section of a prism is perpendicular to all the lateral edges.*

467. *The lateral faces of a right prism are rectangles.*

468. *The altitude of a right prism is equal to a lateral edge.*

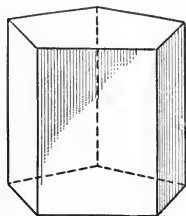

EXERCISES

3. If a right section of a prism is a rectangle, then the adjacent lateral faces of the prism are perpendicular to each other.

4. If a right section of a prism is an equilateral triangle, then every section having one of its sides parallel to one of the sides of the given section is an isosceles triangle.

469. Truncated prism. If a prism is cut by two nonparallel planes which do not meet inside the prism, the portion of the prism between the planes is called a *truncated prism*.

If one of the cutting planes is perpendicular to a lateral edge, the figure is called a *right truncated prism*.

QUERY 1. What kind of figures are the lateral faces of a truncated prism?

QUERY 2. How many lateral faces of a truncated prism can be parallelograms?

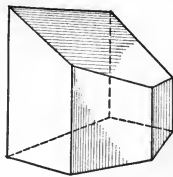

EXERCISE 5. If in two right truncated prisms three lateral edges of one are equal respectively to three lateral edges of the other, and the bases to which these edges are perpendicular are congruent, the right truncated prisms are congruent.

HINT. Prove by superposition.

470. Parallelepiped. A prism whose bases are parallelograms is called a *parallelepiped*.

From this definition, together with the definition of a prism, it follows that all the faces of a parallelepiped are parallelograms. It follows from § 465 and § 407 that any pair of opposite faces of a parallelepiped are parallel. Hence we may consider any two opposite faces of a parallelepiped as its bases.

471. Right parallelepiped. If a parallelepiped is a right prism, it is called a *right parallelepiped*.

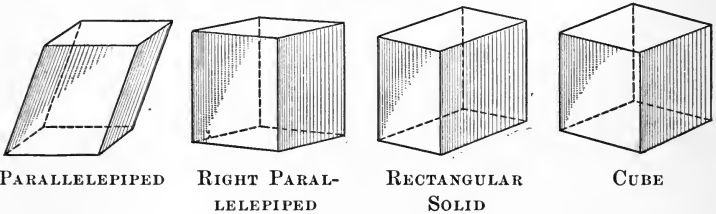

We shall assume that the base of a right parallelepiped is one of the two faces to which the edges are perpendicular.

472. Rectangular solid. A right parallelepiped whose bases are rectangles is called a *rectangular solid*.

The lengths of the edges of a rectangular solid which meet at one vertex are called its *dimensions*. It should be noted that the dimensions of a rectangular solid are numbers.

473. Cube. If three edges of a rectangular solid which meet in the same point are equal, the figure is called a *cube*.

From this definition it appears that the three dimensions of a cube are equal to each other.

474. Diagonal. A *diagonal* of a polyhedron is a line-segment joining two vertices which do not lie in the same face.

QUERY 1. How many altitudes does a parallelepiped have? Are any two of them necessarily (1) perpendicular, (2) equal?

QUERY 2. Are any two altitudes of a rectangular solid necessarily (1) perpendicular, (2) equal to each other?

QUERY 3. Are each of the lateral edges of (1) a right parallelepiped, (2) a rectangular solid, necessarily equal to one of the altitudes?

QUERY 4. Can two lateral faces of (1) a parallelepiped, (2) a rectangular solid, be equal without being congruent?

QUERY 5. Are the adjacent lateral faces of (1) a rectangular solid, (2) a right parallelepiped, perpendicular to each other?

QUERY 6. How many diagonals from each vertex has (1) a parallelepiped, (2) a prism whose base is a pentagon?

QUERY 7. If a parallelepiped has a rectangular base, is it necessarily a right parallelepiped? Is it necessarily a rectangular solid?

QUERY 8. What kind of figures are the faces of a cube?

QUERY 9. Is an altitude of (1) a parallelepiped, (2) a rectangular solid, necessarily equal to the altitude of any one of its faces?

QUERY 10. Show how to pass a plane cutting a cube so that the section will be (1) a parallelogram, (2) a square, (3) a hexagon, (4) a triangle, (5) an equilateral triangle.

EXERCISES

6. A plane which contains only one lateral edge of a prism is parallel to all of the other edges.

7. Prove that if two cubes have equal edges they are congruent.

8. Prove that the three diagonals of a parallelepiped meet in a point.

9. Prove that the diagonals of a rectangular solid are equal to each other.

10. Prove that any line through the point of intersection of the diagonals of a parallelepiped and terminated by opposite faces of the parallelepiped is bisected at that point.

11. If the dimensions of a rectangular solid are a , b , and c , what is the length of the diagonal?

NOTE. Strangely enough the problem of this exercise is not solved in any of the works of the ancient geometers. It was first published in 1220 by an Italian named Fibonacci.

12. If the diagonal of a cube is $4\sqrt{3}$, what is its edge?

13. If two edges of a rectangular solid are 6 and 8 respectively, and the diagonal is 12, what is the third edge?

14. Can an umbrella 38 inches long be packed in a trunk whose inside dimensions are $34 \times 24 \times 12$ inches?

15. If the angles of the faces meeting at a given vertex of a parallelepiped are 80° , 120° , and 50° respectively, what are the angles at the other vertices?

16. Find the sum of all the face angles of a parallelepiped.

17. If the altitude of a parallelepiped is 12 inches, and the lateral edges make an angle of 30° with the base, find the length of the lateral edges.

18. Show that the diagonals of a cube do not meet at right angles.

19. Prove that the mid-points of the edges of a cube, which are denoted by A, B, C, D, E, F in the adjacent figure, are all equidistant from the vertex O and are the vertices of a regular hexagon.

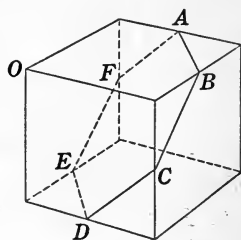

20. Prove that the sum of the plane angles of the dihedrals formed by the faces of a parallelepiped is 12 right angles.

21. Prove that if two planes, each determined by a pair of lateral edges of a prism, meet, their intersection is parallel to the lateral edges.

22. Construct a parallelepiped whose edges are equal and parallel to three given nonparallel line-segments in space.

VOLUMES

475. Volume. If one wishes to determine with a moderate degree of accuracy the volume of an open vessel, one may fill the vessel with water and then dip the water out with a quart measure. The number of times the quart measure is filled denotes the volume of the vessel when the unit of measure is one quart. This number might be, not an integer, but an integer plus a proper fraction. If a measure in the form of a cube one inch on an edge were used instead of a quart measure, the volume would be a different number, because the unit of measure is different. If a smaller unit of measure is taken, the volume of the vessel would be likely to be obtained with greater accuracy, since the amount left over after the last full measure would probably be less than when a large measure is used. It is clear that any unit of measure is contained a certain number of times in any solid, whatever its size and shape. That number might conceivably be an integer or a fraction or even an irrational number. We may thus give the following definition:

The *volume* of a solid is the number of times it contains a given solid which is taken arbitrarily as the unit of volume.

It will be assumed that every solid which is considered in this text has a volume. One object of the study of solid geometry is to find an expression or formula for the volume of some of the simpler solids.

For the purpose of this discussion a cube whose edge is a linear unit, as one inch or one centimeter, will be taken as the unit of volume.

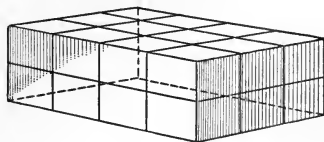

Consider a rectangular solid whose edges are respectively 3, 4, and 2 inches. Pass planes as indicated in the figure

parallel to the faces of the solid and dividing the edges into segments one inch long. These planes will divide the base of the rectangular solid into a checkerboard arrangement containing $3 \times 4 = 12$ squares, each of which is the base of a cube formed by others of the planes. Since the altitude of the rectangular solid is 2, there will be 2 layers of 12 congruent cubes each, making $3 \times 4 \times 2 = 24$ unit cubes in all. Hence the unit of volume is contained 24 times in the rectangular solid. This number may be obtained by multiplying together the three dimensions of the rectangular solid.

If a rectangular solid has edges $3\frac{1}{3}$, $4\frac{1}{6}$, $2\frac{1}{2}$ inches respectively, it would be more convenient to take as a unit a cube whose edge is contained evenly in each of the given edges. The dimensions of this rectangular solid may be written $\frac{20}{6}$, $\frac{25}{6}$, $\frac{15}{6}$. Taking as unit a cube with an edge $\frac{1}{6}$ of an inch long, and proceeding as before, the rectangular solid is divided into 15 layers of little congruent cubes, each layer containing 20×25 of these unit volumes. Hence the volume of the cube is $20 \times 25 \times 15 = 7500$ when the unit is a cube of edge $\frac{1}{6}$ inch. If it is desired to find this volume in cubic inches, it is only necessary to observe that there are $6 \times 6 \times 6 = 216$ units of this kind in a cube an inch on a side, which gives $\frac{20 \times 25 \times 15}{216} = \frac{20}{6} \times \frac{25}{6} \times \frac{15}{6} = 3\frac{1}{3} \times 4\frac{1}{6} \times 2\frac{1}{2} = 34\frac{1}{8}$ as the volume in cubic inches. Hence in this case also the volume of the rectangular solid is the product of its three dimensions.

When the three dimensions of the cube are numbers which do not have a common measure, like 2, $\sqrt{3}$, $\sqrt[3]{6}$, we might get the approximate volume by extracting the roots indicated to several decimal places, and taking as a unit a cube whose edge is a common measure of these approximate values of the edges. The approximate volume of the rectangular solid which is found is a little too small or too great, according as

the approximate values of the edges are taken smaller than or greater than the true values; but in either case the approximate volume of the rectangular solid is found by taking the product of the approximate values of its edges. This leads to the following assumption:

476. Assumption. *The volume of a rectangular solid is the product of its three dimensions.*

Since the product of any two dimensions of a rectangular solid is the area of a base, we may state the preceding assumption as follows:

The volume of a rectangular solid is the product of a base by the corresponding altitude.

Prove each of the following properties of rectangular solids:

477. *The volumes of any two rectangular solids are to each other as the products of their three dimensions.*

Proof. Denote by V and V' the volumes of the rectangular solids whose dimensions are a, b, c and a', b', c' respectively. Then

$$V = abc \text{ and } V' = a'b'c'. \text{ Hence } \frac{V}{V'} = \frac{abc}{a'b'c'}.$$

478. *The volumes of two rectangular solids having one dimension in common are to each other as the products of the other two.*

479. *The volumes of two rectangular solids having two dimensions in common are to each other as their third dimensions.*

480. Method of comparing volumes. Suppose we form several piles of cards 2×3 inches, each pile being 4 inches high. The piles may be in the shape either of a rectangular solid, or of a parallelepiped, or of some other irregular solid. But since the various piles consist of the same number of cards which are just alike, they must have the same volume.

The fact that all of the cards have the same area is expressed in geometric language by saying that all plane sections of each of the figures parallel to their bases are equal in area.

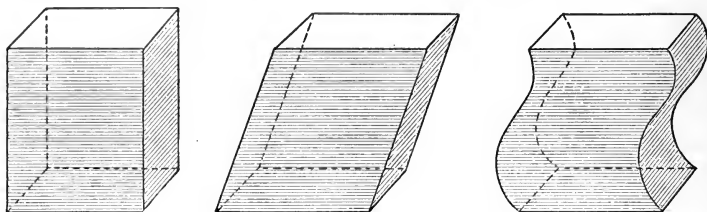

But the cards need not all be equal in order to afford piles of equal volume. If we have a pile of cards in the form

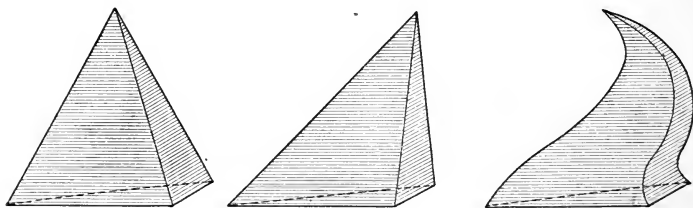

of a pyramid, we may distort it in any of the ways indicated in the diagrams without affecting the volume of the solid.

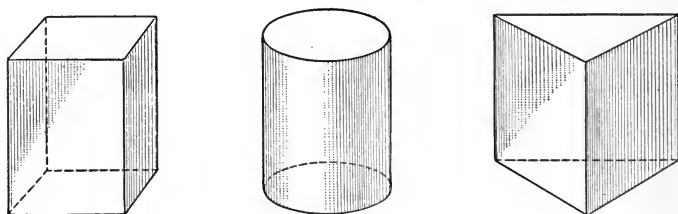

Moreover, the sheets need not be of the same shape. A square card 2 inches on a side has the same volume as a circular card of the same thickness whose area is 4 square

inches or a triangular card of the same area. Hence a pile of 100 of the square cards would have the same volume as a pile of an equal number of the round ones or of the triangular ones.

We now assume without proof Cavalieri's theorem:

481. Cavalieri's theorem. *If in two solids of equal altitude the sections made by planes parallel to and at the same distance from their respective bases are always equal, the solids have the same volume.*

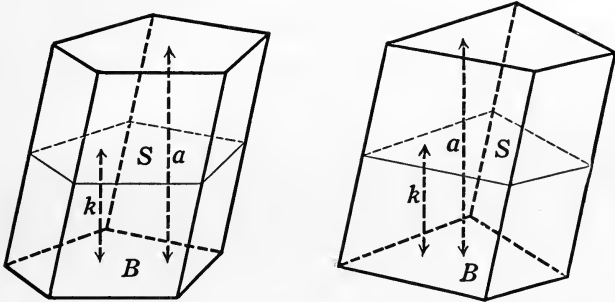

It should be emphasized that the planes mentioned in the theorem may be any distance from the bases of the two figures, but must be the same distance from the base of each. In terms of the piles of cards, this means that cards the same distance up in each pile must have the same size in order that the piles may have equal volumes.

NOTE. The Italian mathematician Bonaventura Cavalieri was born in 1598 and died in 1647 at Bologna.

The principle known under his name was first used by him for the case of plane figures. That is to say, he stated the theorem which is given in the preceding section in such a way as to include not only the volume of certain solids but also the area of certain plane figures. The form in which he stated his theorem is as follows:

Plane and solid figures are equal in content when sections drawn at the same height from the base produce equal lines or areas.

A rigorous demonstration of the validity of this assumption can be given by use of the methods of the calculus.

QUERY 1. If two prisms have equal bases, are the sections of the two figures made by planes parallel to the bases necessarily equal?

QUERY 2. How many parallelograms are there with a given base and altitude? What can be said about the volumes of the parallelepipeds having the same altitude, which are constructed on these parallelograms as bases?

QUERY 3. If a pyramid and a prism have congruent bases and equal altitudes, would sections the same distances from their bases be congruent? Do you think that the two figures have the same volume?

Theorem 2

482. *Two prisms having equal bases and equal altitudes are equal in volume.*

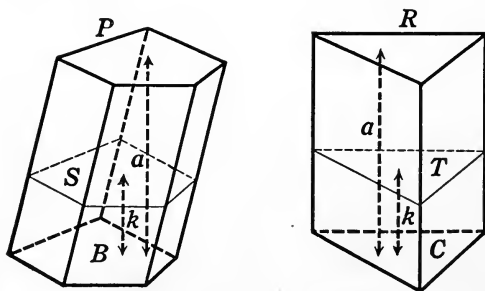

Given any two prisms P and R , having equal altitudes a , and bases B and C , which are equal in area.

To prove that P and R are equal in volume.

Proof. Pass planes \parallel to the bases of the prisms P and R , at any distance, k , from the corresponding bases.

Call the areas of the sections thus formed S and T respectively.

Then $S = B$ and $T = C$. § 459

But $B = C$. Given

Hence $S = T$. § 32

Therefore $P = R$. § 481

483. Corollary. *A plane which passes through the opposite parallel edges of a parallelepiped divides it into two equal triangular prisms.*

EXERCISE 23. Two right prisms are equal if three faces which meet at a vertex of one are respectively equal to three faces similarly placed, which meet at a vertex of the other.

HINT. The faces which are given equal must include among them a base of each prism.

Theorem 3

484. *The volume of any prism is equal to the product of its base and altitude.*

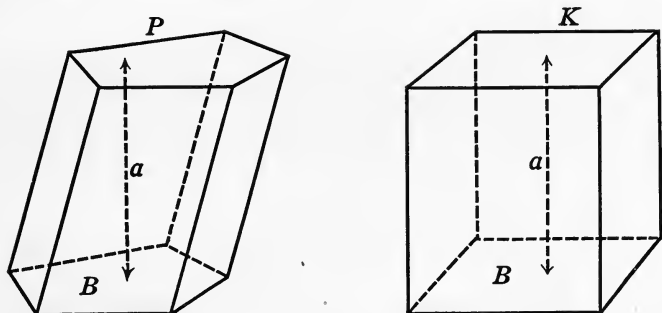

Given any prism P , with base B and altitude a .

To prove that $\text{volume } P = B \cdot a$.

Proof. Let K be a rectangular solid having its base equal to B and its altitude equal to a .

Volume $K = B \cdot a$. § 476

But the base and altitude of P equal those of K . Const.

Hence $\text{volume } P = \text{volume } K$. § 482

Therefore $\text{volume } P = B \cdot a$. Why?

485. Corollary. *The volume of a parallelepiped equals the product of the area of any face and the altitude on that face.*

QUERY 1. Is the volume of any parallelepiped equal to the product of its three altitudes? Give an example.

QUERY 2. In what case is the volume of a parallelepiped equal to the product of three of its edges?

QUERY 3. In what kind of a triangular prism would the volume be equal to one half the product of its three edges?

EXERCISES

24. Construct a rectangular solid whose base is equal in area to that of a given triangular prism, and which has an altitude equal to that of the prism. Give a reason for each step.

25. Prove that the volume of a triangular prism is equal to one half the product of the area of a given lateral face and the distance to that face from the opposite lateral edge.

Theorem 4

486. *The lateral area of a prism equals the product of a lateral edge and the perimeter of a right section.*

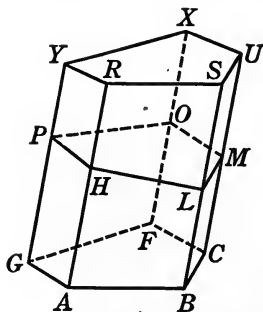

Given any prism $A-X$, of which $HLMOP$ is a right section, and one of whose lateral edges is AR .

To prove that lateral area of $A-X = \text{perimeter of } H-O \cdot AR$.

Proof. Plane $H-O$ is \perp to AR , BS , CU , etc.

§ 466

AR is \perp to HL , BS to LM , CU to MO , etc.

Why?

Hence the lateral faces of the prism are parallelograms, each having one of the line-segments HL , LM , MO , etc. as its altitude, and each having a base equal to AR . § 465

Hence

$$\begin{aligned} \text{area } AY &= AR \cdot PH, \\ \text{area } BR &= BS \cdot HL, && \text{Why?} \\ \text{area } CS &= CU \cdot ML. \\ &\dots \end{aligned}$$

Adding, $\text{area}(AY + BR + CS + \dots) = AR(PH + HL + LM + \dots)$,
 or lateral area of $A-X = \text{perimeter of } H-O \times AR$. § 458

487. Corollary. *The lateral area of a right prism is equal to the product of its altitude and the perimeter of its base.*

QUERY. If the shape of a prism is varied by moving the upper base about in its plane while the lower base remains fixed in position, does the volume of the prism vary? Does the lateral area vary?

EXERCISES

In the following exercises, h represents the altitude, n the number of sides of the base, b one side of the base, B the area of the base, V the volume, S the lateral area, and T the total area, of a prism.

- 26. Given $V = 50$, $B = 25$. Find h .
- 27. Given $h = 8\frac{1}{3}$, $B = 6$. Find V .

In Exercises 28–35 the prism is regular.

- 28. Given $h = 12$, $b = 3$, $n = 3$. Find S .
- 29. Given $h = 10$, $b = 4$, $n = 4$. Find V .
- 30. Given $h = 6\frac{2}{3}$, $S = 80$, $n = 4$. Find V .
- 31. Given $V = 56$, $B = 14$. Find h .
- 32. Given $V = 300$, $n = 3$, $h = 20$. Find b .
- 33. Given $n = 4$, $h = 6$, $V = 1536$. Find b .
- 34. Given $n = 3$, $b = 6$, $h = 8$. Find T .
- 35. Given $n = 6$, $b = 8$, $V = 128$. Find T .

36. Find the lateral area of a right prism whose base is a rectangle 6×8 inches and whose altitude is 1 foot. Find also the total area.

37. Find the lateral area of a prism whose base is an equilateral triangle 4 inches on a side, and whose altitude is 10 inches. Find also the total area.

38. The total area of a cube is 216 square inches. Find the edge and the volume.

39. Sand lies against a vertical wall, reaching a point 3 feet high. If the sand just lies at rest with its surface at an angle of 30° with the horizontal, how many cubic feet of sand are there in a pile 20 feet long? Assume that the ends of the pile are perpendicular to its length.

40. What is the weight of a block of ice $24 \times 24 \times 18$ inches if ice weighs 92 per cent as much as water? (Cubic foot of water weighs 62.5 pounds.)

41. A railway cut 25 feet deep is to be made with one side vertical and the other inclined at an angle of 45° to the vertical. The bottom is to be 30 feet wide. How many cubic feet of material must be removed per running foot of track?

42. Express T in terms of V for a cube.

43. If d is the diagonal of a cube, express V in terms of d .

44. Express V in terms of b and h for a triangular prism whose base is equilateral.

45. Find correct to two decimal places the edge of a cube equal in volume to a prism whose base is a regular hexagon 4 inches on a side and whose altitude is equal to an edge of the cube.

46. The altitude and base of a parallelepiped are 6 and 8 inches respectively, and a lateral edge whose length is 10 inches makes an angle of 60° with the base. Find the volume.

47. A regular hexagonal prism whose lateral edge makes an angle of 60° with the plane of its base has an altitude of 12 feet, while one edge of the base is 4 feet. What is its lateral area?

CYLINDERS

488. Cylindrical surface. If a line moves, always remaining parallel to its first position and always cutting a fixed plane curve not situated in the plane of the line, the surface generated is called a *cylindrical surface*.

The moving line is called the *generator*; in one of its positions it is called an *element*; the fixed curve is called the *directrix* of the surface.

From the definitions just given it follows that the elements of a cylinder are parallel (§ 406).

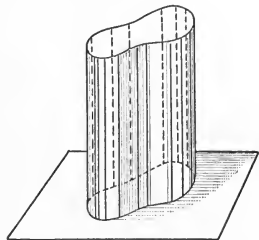

In this text the directrix will be assumed to be a closed curve, although in more advanced mathematical work the directrix is often an open curve, or even a curve consisting of several branches.

A convex curve is one which a straight line can cut in no more than two points. A convex cylindrical surface has a convex curve as directrix. Only convex cylindrical surfaces are studied in this text.

489. Corollary. *Each point of a cylindrical surface lies on one and only one element of the surface.*

HINT. Suppose a certain point were contained by two elements.

490. Cylinder. The solid bounded by a cylindrical surface and two parallel planes cutting the elements is called a *cylinder*.

The terms *altitude*, *base*, *right section*, *lateral area*, *volume*, and *right cylinder* are defined similarly to the corresponding terms applied to the prism (§ 458).

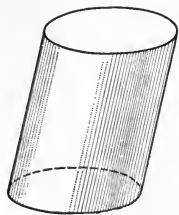

491. Circular cylinder. If a cylinder has a circular right section, it is called a *circular cylinder*.

EXERCISE 48. Define the terms mentioned in § 490.

Theorem 5

492. *The sections of a cylindrical surface by two parallel planes, one of which cuts an element, are congruent.*

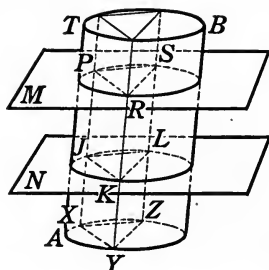

Given any cylindrical surface AB , of which one element AT is cut by the plane M , which is parallel to the plane N .

To prove that the sections formed are congruent.

Proof. The plane M cuts all the elements of AB . § 402

Take any three points P, R, S at random in the intersection of the surface by M , and let PX, RY, SZ be the elements of the surface containing these points. § 489

Let the elements PX, RY , and SZ cut N in the points J, K , and L respectively. § 403

Let the intersections of M and N with the planes determined by the parallel lines PJ, RK, SL be PS, JL , etc.

PS is \parallel to JL . § 393

Hence PL is a parallelogram, and $PS = JL$. §§ 83, 85

Similarly, $SR = LK$ and $RP = KJ$.

Therefore $\triangle PRS$ is congruent to $\triangle JKL$. Why?

Since P, R , and S were taken at random, it follows that if the upper section is applied to the lower one so that PS coincides with JL , any other point, as R , of the upper section will coincide with the point of the lower section which is on the same element.

Hence any point of the upper section coincides with some point of the lower.

Similarly it can be shown that any point of the lower section coincides with some point of the upper.

Therefore the upper and lower sections are congruent.

493. Corollary. *The bases of a cylinder are congruent.*

Theorem 6

494. *The section of a cylinder made by a plane which contains an element of the cylinder and a point of the cylindrical surface not in this element is a parallelogram.*

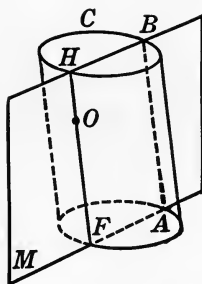

Given any cylinder C and a plane M which contains an element AB and a point O of the cylindrical surface not on AB .

To prove that the section formed is a parallelogram.

Proof. Denote by FH the element through O .

Now FH is \parallel to AB . § 488

If FH cut M , AB would also cut M . § 402

Therefore FH lies in M and also in the surface of C .

Let M intersect the bases of C in HB and FA .

HB is \parallel to FA . Why?

Hence $ABHF$ is a parallelogram each side of which lies in both the plane and the surface of the cylinder.

Therefore the section of C by M is a parallelogram.

QUERY 1. Would the section of the cylinder made by the plane determined by an element and any point in one of the bases be a parallelogram?

QUERY 2. What kind of cylinder may have a square as a section? a rectangle? a rhombus?

EXERCISES

49. Every section of a right cylinder made by a cutting plane perpendicular to the base is a rectangle.

50. The intersection of a right cylinder and a plane which passes through an element is a rectangle.

495. **Inscribed prism.** If the bases of a prism are inscribed in the bases of a cylinder, and the lateral edges of the prism are elements of the cylinder, the prism is said to be *inscribed* in the cylinder.

QUERY 1. Can a regular prism be inscribed in any given right circular cylinder?

QUERY 2. Can a regular prism be inscribed in any given circular cylinder?

QUERY 3. Can a rectangular solid be inscribed in any given right circular cylinder?

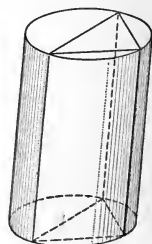

EXERCISES

51. Construct a triangular prism inscribed in a given right circular cylinder, giving a reason for each step.

52. Construct a regular hexagonal prism inscribed in a given right circular cylinder, giving a reason for each step.

496. **Volume of cylinder.** If the base of a prism which is inscribed in a cylinder has a very large number of sides, and each side is very short, then the area and the perimeter of the base of the prism are approximately equal to the area and the perimeter respectively of the base of the cylinder. By taking the sides sufficiently short, as close approximations as may be desired can be obtained.

The inscribed prism whose base is almost the same in area as that of the circumscribing cylinder will have a large number of very narrow parallelograms as its lateral faces, and its lateral area and volume will differ very little from the lateral area and volume respectively of the cylinder.

But the volume of the prism, however many lateral faces it may have, is the product of its base and its altitude, and the lateral area of the prism is the product of the perimeter of a right section and a lateral edge. Since the volume and the base of the cylinder become very nearly equal to the volume and the base respectively of the inscribed prism,

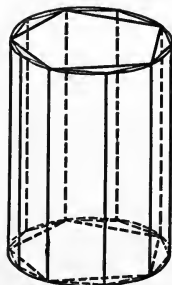

when the number of its faces is sufficiently increased, and since the altitudes of the two figures are identical, we are led to the following statements, which we here assume without proof, but which can be demonstrated by the theory of limits.

Theorem 7

497. *The volume of a cylinder equals the product of the area of its base and its altitude.*

498. Corollary. *The volume of a right circular cylinder is equal to $\pi r^2 h$, where r denotes the radius of the base and h the altitude of the cylinder.*

Theorem 8

499. *The lateral area of a cylinder is equal to the product of the perimeter of a right section and an element.*

500. Corollary 1. *The lateral area of a right circular cylinder is equal to $2\pi rh$, where r denotes the radius of the base and h the altitude of the cylinder.*

501. Corollary 2. *The total area of a right circular cylinder is equal to*

$$S = 2 \pi r h + 2 \pi r^2 = 2 \pi r (h + r).$$

NOTE. Many theorems concerning the prism are equally true when applied to the cylinder. Theorems 7 and 8 illustrate this important fact, which may be stated in general terms as follows: Any theorem regarding the prism which does not depend on the number of lateral faces is true for the cylinder.

QUERY 1. The lateral surface of a cylinder is cut along an element and rolled out flat. What kind of figure is obtained?

QUERY 2. What is the locus of points a given distance from a given line?

QUERY 3. What is the locus of points a given distance from two given parallel lines?

QUERY 4. What is the locus of points a given distance from a given cylinder?

QUERY 5. What is the locus of points a given distance from a given line and equidistant from two parallel planes to which the given line is perpendicular? What if the planes are not perpendicular to the given line?

EXERCISES

In the following exercises, all of which relate to right circular cylinders, h represents the altitude, r the radius of the base, S the lateral area, T the total area, and V the volume:

53. Given $r = 2$, $h = 2$. Find T .
54. Given $r = 4$, $h = 9$. Find V .
55. Given $r = 5$, $h = 21$. Find S .
56. Given $r = 4$, $V = 42$. Find S .
57. Given $T = 235$, $r = 3$. Find V .
58. Given $S = 121$, $r = 2$. Find h .
59. Given $r = 2$, $V = 64$. Find h .
60. Given $V = T$, $r = 7$. Find S .
61. Given $S = V$, $h = r$. Find r .

Theorem 9

502. *If a rectangle is revolved about one side as an axis, the figure formed is a right circular cylinder.*

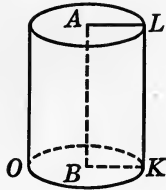

Given any rectangle $ABKL$ which revolves about AB as an axis.

To prove that the figure generated is a right circular cylinder.

Proof. AL and BK each generate a plane \perp to AB . § 418

Therefore the planes generated are parallel. Why?

The points K and L describe circles in these planes. Why?

KL generates a cylindrical surface. § 488

Hence the figure $O-L$ is a right circular cylinder. Why?

503. **Cylinder of revolution.** A right circular cylinder is often called a *cylinder of revolution* when it is desired to emphasize the foregoing method of generation.

504. **Axis of cylinder.** The line joining the centers of the bases of a right circular cylinder is called the *axis* of the cylinder.

EXERCISES

62. The axis of a cylinder of revolution is equal and parallel to the elements of the cylinder.

63. The axis of a cylinder of revolution passes through the center of every plane section of the cylinder parallel to its base.

505. **Similar cylinders.** If two cylinders of revolution are generated by the rotation of similar rectangles about corresponding sides, the cylinders are said to be *similar*.

Theorem 10

506. *If two cylinders of revolution are similar,*

(a) *their volumes are proportional to the cubes of their altitudes or of their radii;*

(b) *their lateral surfaces, or their total surfaces, are proportional to the squares of their altitudes or of their radii.*

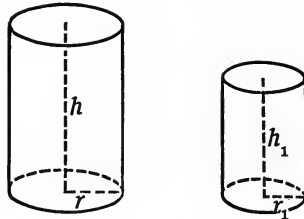

Given any two similar cylinders of revolution with radii r and r_1 , and altitudes h and h_1 , respectively.

Let V and V_1 , S and S_1 , T and T_1 represent the volumes, lateral surfaces, and total surfaces, respectively.

To prove

$$(a) \quad \frac{V}{V_1} = \frac{r^3}{r_1^3} = \frac{h^3}{h_1^3},$$

$$(b) \quad \frac{S}{S_1} = \frac{T}{T_1} = \frac{r^2}{r_1^2} = \frac{h^2}{h_1^2}.$$

Proof. (a) $\frac{V}{V_1} = \frac{\pi r^2 h}{\pi r_1^2 h_1} = \frac{r^2}{r_1^2} \cdot \frac{h}{h_1}. \quad (1) \quad \S 498$

But $\frac{h}{h_1} = \frac{r}{r_1}. \quad (2) \quad \S\S 505, 268$

Hence, from (1) and (2),

$$\frac{V}{V_1} = \frac{r^2}{r_1^2} \cdot \frac{h}{h_1} = \frac{r^2}{r_1^2} \cdot \frac{r}{r_1} = \frac{r^3}{r_1^3} = \frac{h^3}{h_1^3},$$

$$(b) \quad \frac{S}{S_1} = \frac{2\pi r h}{2\pi r_1 h_1} = \frac{r}{r_1} \cdot \frac{h}{h_1} = \frac{r^2}{r_1^2} = \frac{h^2}{h_1^2} \quad (3) \quad \S 500$$

and $\frac{T}{T_1} = \frac{2\pi r(r+h)}{2\pi r_1(r_1+h_1)} = \frac{r}{r_1} \cdot \frac{r+h}{r_1+h_1}. \quad (4) \quad \S 501$

But from (2), $\frac{r}{r_1} = \frac{r+h}{r_1+h_1}$. (5) §§ 257, 262

Hence, from (4), (5), and (2),

$$\frac{T}{T'} = \frac{r}{r_1} \cdot \frac{r+h}{r_1+h_1} = \frac{r^2}{r_1^2} = \frac{h^2}{h_1^2}.$$

507. Theorem of Pappus. If a circle is revolved about a line lying in its plane but not intersecting it, a figure called an *anchor ring* or *torus* is formed. If one imagines the torus cut along one of the generating circles and straightened out so as to form a

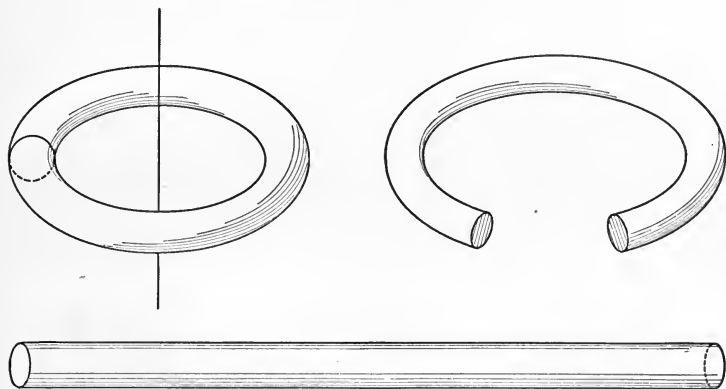

cylinder, one would expect that the altitude of the cylinder would be the line described by the center of the generating circle in its revolution. That this is the case can be proved by means of the calculus; in fact, a much more general theorem can be demonstrated, which is called

The Theorem of Pappus. *If a closed curve (or polygon) rotates about an axis lying in its plane, the volume of the ring described equals that of the cylinder (or prism) whose base is the generating figure and whose altitude is the length of the curve described by the center of gravity of the generating figure.*

The area of the surface of the ring generated equals the lateral area of the cylinder (or prism) described.

NOTE. This theorem was first discovered by Pappus of Alexandria (third century of the Christian era). His work was forgotten for more than twelve hundred years, until the interest in the subject was revived at the end of the sixteenth century by the works of Kepler and Guldin.

Kepler (1571-1630) investigated a number of solids generated by the rotation of a plane figure and succeeded in finding rules for computing their volumes in certain particular cases. All of his rules are special cases of the Theorem of Pappus, although Kepler never announced the theorem in its general form.

Among the solids treated by Kepler were the torus and the solid termed by him "the apple," which is formed by revolving a segment greater than half a circle around its chord as an axis, and "the lemon," which is formed by revolving a segment of a circle with an arc less than 180° around its chord as an axis. The Jesuit, Paul Guldin (1577-1643), who was a professor of mathematics in Rome and in Graz, was the first after Pappus to give a statement of the theorem in its general form in a work published in 1640. He failed, however, to give a satisfactory proof of the general case.

The Theorem of Pappus was later generalized by Leibniz and Euler. Leibniz (1646-1716) noticed that the theorem holds true when the moving plane figure moves along any path to which it always remains perpendicular.

EXERCISES

64. The center of a circle of radius 4 inches is 10 inches from the axis about which it rotates to form a torus. Find (1) the volume, (2) the surface of the torus.

Solution. Applying the Theorem of Pappus, we have

$$V = 2 \pi 10 \cdot \pi 4^2 = 320 \pi^2 \text{ cubic inches.}$$

$$S = 2 \pi 10 \cdot 2 \pi 4 = 160 \pi^2 \text{ square inches.}$$

65. How many cubic feet of water will a 90° elbow of an 8-inch water main contain if the axis about which the generating circle of the elbow rotates is 12 inches from the center of the circle?

66. How much will an iron elbow of Exercise 65 weigh if the iron is one-half inch thick? (A cubic foot of iron weighs about 480 pounds.)

67. A rectangle 2×4 inches rotates about a line parallel to the nearer one of the shorter sides and 6 inches from it. Find (1) the volume, (2) the area of the solid generated.

68. Compare the results of the foregoing exercise with those obtained if the same rectangle is rotated about an axis 6 inches from the longer side.

69. The cross section of the rim of an iron flywheel 3 feet in diameter is a rectangle 12×2 inches. How much does it weigh?

508. **Tangent plane.** A plane which contains an element of a cylindrical surface and meets the surface nowhere else is said to be *tangent* to the cylinder.

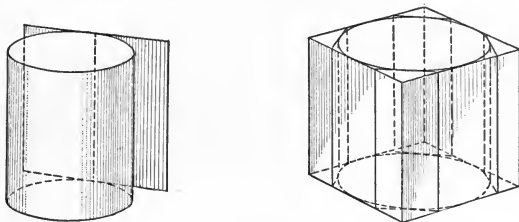

509. **Circumscribed prism.** A prism is said to be *circumscribed* about a cylinder when its bases are polygons circumscribed about the bases of the cylinder and its lateral faces are tangent to the cylinder.

EXERCISES

70. The ratio of the volume of a cylinder to that of its inscribed or circumscribed prisms is equal to the ratio of their corresponding bases.

71. A cylinder is generated by the revolution of a rectangle 2×6 inches about the shorter side. Find the volume and the total area.

72. A cylinder is generated by the revolution of a rectangle 2×6 inches about the longer side. Find the volume and the total area.

73. Two cylinders are generated by the revolution of a rectangle $a \times b$ inches, first about the side a , then about the side b . Find the ratio (1) of the volumes, (2) of the total areas, (3) of the lateral areas, of the cylinders formed.

74. The edge of a cube is 8 inches. Find the volume of the circumscribed cylinder.

75. The lateral area of a cube is 54 square inches. Find the lateral area of the inscribed cylinder.

76. A tank is $2 \times 3 \times 4$ feet. It is desired to make a cylindrical tin tank, without a lid, of the same volume and having an altitude of 3 feet. Find the number of square feet of tin in the new tank.

77. A cylindrical gasoline tank 48 inches long and of diameter 16 inches is on its side in a horizontal position. The greatest depth of the gasoline is 1 foot. How many gallons are required to fill the tank? (231 cubic inches = 1 gallon.)

78. Find the volume of a cylinder of revolution inscribed in a regular hexagonal prism whose altitude is 8 inches and whose lateral area is 288.

79. Find the diameter of a cylinder of revolution if the volume is equal numerically to (1) the total area, (2) the lateral area.

80. The radius of a cylinder of revolution is 7 inches, and its altitude is 15 inches. Find the distance from the axis of the cylinder to the plane parallel to the axis which makes a section of the cylinder equal in area to the base. (Use $\pi = 22/7$.)

81. What is the ratio of the diameter to the altitude of a cylinder of revolution if the area of the greatest section made by a plane through an element is equal to that of the base?

82. A cylinder of revolution is of radius 8 inches. Two tangent planes are drawn to the cylinder through a point 8 inches from the surface of the cylinder. What is the angle between the planes?

83. What is the diameter of a cylindrical quart measure which is 4 inches high?

PYRAMIDS

510. Pyramid. A *pyramid* is the solid bounded by a polygon and triangles having the sides of the polygon as their bases and having a common vertex.

The polygon is called the *base* of the pyramid; the triangles are called the *lateral faces*; and the common vertex of the lateral faces is called the *vertex*.

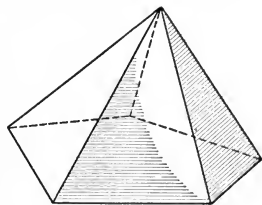

The intersections of the lateral faces are called the *lateral edges* of the pyramid.

Pyramids are triangular, quadrangular, hexagonal, etc., according as their bases have three, four, six, etc. sides.

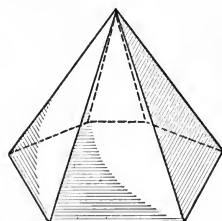
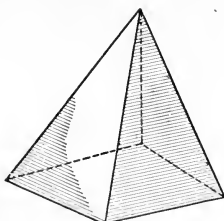
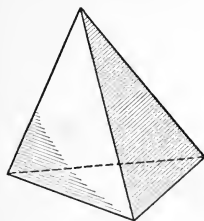

511. Lateral area. The sum of the areas of the lateral faces is the *lateral area* of the pyramid.

512. Altitude. The *altitude* of a pyramid is the perpendicular distance from the vertex to the plane of the base.

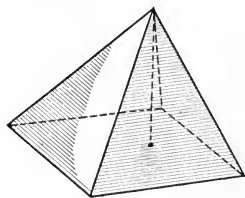

QUERY 1. Can the altitude of a pyramid be equal to one of the lateral edges?

QUERY 2. To how many lateral edges can the altitude of a pyramid be equal?

QUERY 3. For what kind of pyramid may any one of the faces be taken as the base?

QUERY 4. From the adjacent figure name the various parts of the pyramid which have been defined.

QUERY 5. How many pyramids are there with a given base and a given altitude? What is the locus of their vertices?

QUERY 6. As the vertex of a pyramid becomes very remote from the base, what relation to each other do the lateral edges approach?

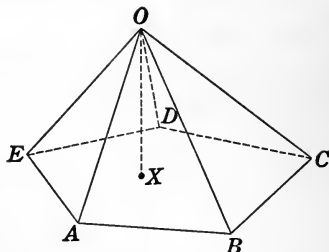

513. Pyramidal surface. The lateral faces of a pyramid may be generated by the motion of a line always passing through a fixed point, the vertex, and continually meeting the perimeter of a fixed polygon.

If we consider the figure generated by the entire line, we have not merely the lateral surface of the pyramid, but a surface extending indefinitely in both directions from the vertex. This surface is called a *pyramidal* (pý rãm'ĩ dal) *surface*.

The terms *generator*, *element*, and *directrix* are applied to the pyramidal surface in the same sense as that defined in § 488.

514. Another definition of a pyramid. A second definition of a pyramid may be given which is identical in meaning with that of § 510 but which is more useful in dealing with certain problems.

A *pyramid* is a solid bounded by a pyramidal surface and a plane which cuts all of the elements on the same side of the vertex.

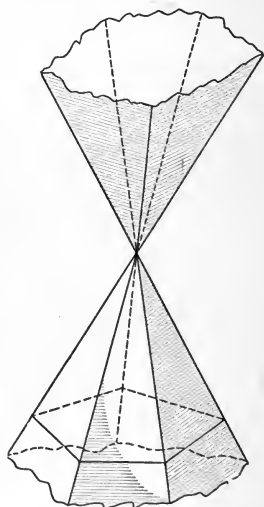

Theorem 11

515. If a pyramid is cut by a plane parallel to the base,
 (a) the lateral edges and the altitude are divided proportionally,
 (b) the section is a polygon similar to the base.

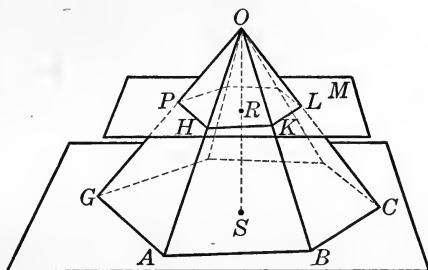

Given any pyramid $O-CG$, cut by a plane M parallel to the base making the section $P-L$. Let the altitude OS intersect M at the point R .

To prove that (a) $\frac{OH}{OA} = \frac{OK}{OB} = \frac{OL}{OC} = \dots = \frac{OR}{OS}$.

(b) $P-L$ is a polygon similar to $G-C$.

Proof. (a) $\frac{OH}{OA} = \frac{OK}{OB} = \frac{OL}{OC} = \dots = \frac{OR}{OS}$. § 411

(b) PH is \parallel to GA ; HK is \parallel to AB ; KL is \parallel to BC ; etc. Why?

Therefore $\angle PHK = \angle GAB$; $\angle HKL = \angle ABC$, etc. Why?

Also $\triangle OAB$ is similar to $\triangle OHK$; $\triangle OBC$ is similar to $\triangle OKL$; etc. § 271

Hence $\frac{HK}{AB} = \frac{OK}{OB}$; $\frac{KL}{BC} = \frac{OK}{OB}$; etc. § 269

Therefore $\frac{HK}{AB} = \frac{KL}{BC}$; etc. Why?

Hence polygon $P-L$ is similar to polygon $G-C$. § 267

Theorem 12

516. *If two pyramids having equal bases and altitudes are cut by planes parallel to their bases and equidistant from their vertices, the sections formed are equal.*

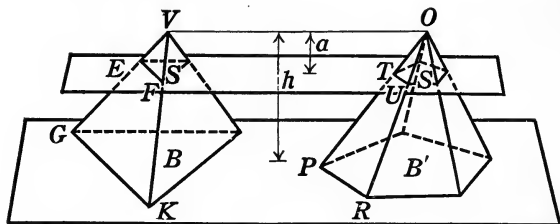

Given any two pyramids, with equal bases B and B' , and with equal altitudes h . Let them be cut by planes parallel to the bases and distant a from the vertices. Let the sections be called S and S' .

To prove that $S = S'$.

Proof. $\frac{EF}{GK} = \frac{VF}{VK}$ and $\frac{TU}{PR} = \frac{OU}{OR}$. Why?

But $\frac{VF}{VK} = \frac{a}{h} = \frac{OU}{OR}$. § 515 (a)

Therefore $\frac{EF}{GK} = \frac{TU}{PR}$, or $\frac{EF^2}{GK^2} = \frac{TU^2}{PR^2}$. Why?

But S is similar to B , and S' is similar to B' . § 515 (b)

Hence $\frac{S}{B} = \frac{EF^2}{GK^2}$ and $\frac{S'}{B'} = \frac{TU^2}{PR^2}$. § 326

Consequently $\frac{S}{B} = \frac{S'}{B'}$. Why?

But $B = B'$. Given

Therefore $S = S'$. Why?

QUERY. In Theorem 12, under what circumstances would the sections made by the planes be congruent?

517. Corollary. *If a pyramid is cut by two parallel planes, the areas of the sections are proportional to the squares of their distances from the vertex.*

QUERY 1. If a plane parallel to the base of a pyramid is halfway between the base and the vertex, what is the ratio of the section to the base?

QUERY 2. How large a shadow will a book 6×8 inches, held 4 feet from a light, cast on a wall parallel to the book and 8 feet away from the light?

QUERY 3. How much larger would the shadow in Query 2 be if the wall of the room were (a) 12 feet, (b) 16 feet from the light?

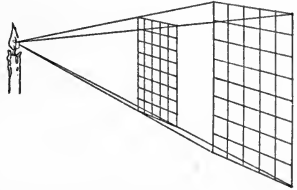

QUERY 4. Explain how the law that the intensity of a light varies inversely with the square of its distance is consistent with § 517.

QUERY 5. If a pyramidal surface is cut by two parallel planes on opposite sides of the vertex (above and below in figure of § 513), are the sections similar?

QUERY 6. If a pyramidal surface is cut by two parallel planes on opposite sides of the vertex and at equal distances from it, are the sections equal? Are they congruent? If the sections are triangles, are they congruent?

EXERCISES

84. A square pyramid has all of its lateral faces equilateral triangles whose sides are each 12 feet. Find the altitude of the pyramid.

85. A pyramid of altitude 6 feet is cut by a plane which makes a section half the area of the base. How far from the vertex of the pyramid is the plane?

86. If a pyramid is cut by two parallel planes, the corresponding sides of the sections are in the same ratio as the distances of the planes from the vertex.

87. If two pyramids having bases of equal perimeter and equal altitudes are cut by planes equidistant from their vertices, the sections formed have equal perimeters.

Theorem 13

518. *Two pyramids having equal bases and equal altitudes are equal in volume.*

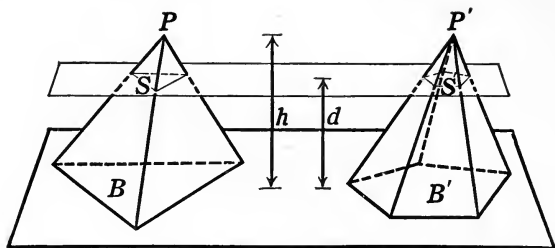

Given any two pyramids P and P' , with equal altitudes h and equal bases B and B' in the same plane.

To prove that $P = P'$.

Proof. At any distance d from the bases pass planes \parallel to the bases of the pyramids, making sections S and S' .

Then $S = S'$. § 516

But d is any distance less than h .

Therefore $P = P'$. § 481

QUERY 1. Is Theorem 13 valid for two pyramids whose bases have different numbers of sides?

QUERY 2. Is the converse of Theorem 13 true?

EXERCISES

88. If a pyramidal surface is cut by two parallel planes, each cutting all the edges on opposite sides of the vertex and at equal distances from it, the pyramids formed are equal in volume.

89. What relation do the two plane sections of Exercise 88 bear to each other? Prove your statement.

Theorem 14

519. *The volume of a triangular pyramid equals one third of the product of its base and altitude.*

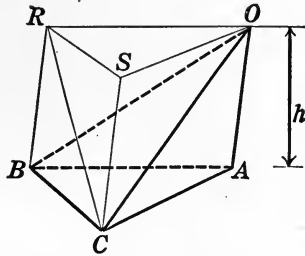

Given any triangular pyramid $O-ABC$, with altitude h .

To prove that the volume $O-ABC = \frac{1}{3} h \times ABC$.

Proof. At B and C construct BR and $CS \parallel$ to OA .

Pass planes determined by pairs of parallels AO, CS ; AO, BR ; BR, CS .

Pass plane ORS through $O \parallel$ to ABC . § 408

The complete figure formed is a triangular prism having ABC as its base and h as its altitude. Why?

Pass plane ORC , dividing the pyramid $O-RBCS$ into the two triangular pyramids $O-RCS$ and $O-RBC$.

$$\triangle ABC = \triangle ORS. \quad \text{Why?}$$

Therefore $O-ABC = C-RSO$. § 518

Also $\triangle RCB = \triangle RCS$. Why?

Therefore $O-RBC = O-RCS$. Why?

But $O-RSC = C-RSO$. Identical

Therefore $O-ABC = O-RCS = O-RBC$. Why?

Hence $O-ABC = \frac{1}{3}$ prism $ABCORS$.

But prism $ABCORS = h \times ABC$. Why?

Therefore volume $O-ABC = \frac{1}{3} h \times ABC$.

NOTE. The relation between the three pyramids into which a prism may be divided, which is demonstrated in the foregoing theorem, is found in Euclid's Geometry and was known by a geometer of even earlier date. It is one of the comparatively few theorems in our modern treatment of solid geometry which has been contained in nearly all the text-books from the earliest times to the present. The Greeks were more interested in the logic of geometry than in its application, and consequently paid more attention to plane geometry than they did to solid.

Theorem 15

520. *The volume of any pyramid equals one third of the product of its base and altitude.*

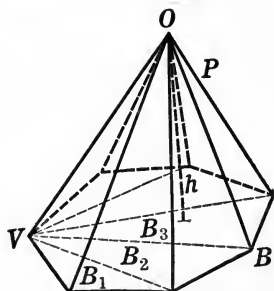

Given any pyramid P , with base B and altitude h .

To prove that $\text{volume } P = \frac{1}{3} B \cdot h$.

Proof. From any vertex V , draw all the diagonals of the base B , dividing it into triangles B_1, B_2, B_3 , etc.

Pass planes determined by these lines of division and the vertex, dividing the pyramid into several triangular pyramids P_1, P_2, P_3 , etc.

h is the common altitude of P_1, P_2, P_3 , etc. § 512

Now $P_1 = \frac{1}{3} B_1 \cdot h$. § 519

$$P_2 = \frac{1}{3} B_2 \cdot h.$$

$$P_3 = \frac{1}{3} B_3 \cdot h.$$

Adding, $P_1 + P_2 + P_3 + \dots = \frac{1}{3} h (B_1 + B_2 + B_3 + \dots)$,

or

$$P = \frac{1}{3} B \cdot h.$$

EXERCISES

90. Two pyramids have bases of equal areas, but one is 14 feet high and the other is 10 feet high. Compare their volumes.

91. Two pyramids have equal altitudes. The base of one is a square 6 feet on a side; that of the other is an equilateral triangle 9 feet on a side. Compare their volumes.

92. Two pyramids have the same altitude. Their bases are respectively a square and a regular hexagon which can be inscribed in the same circle. Compare the volumes.

521. **Frustum of pyramid.** If a plane is passed parallel to the base of a pyramid and cutting the edges, the solid included between the base and the cutting plane is called a *frustum of a pyramid*.

The section formed by the cutting plane is called the upper base, the base of the original pyramid is called the lower base, and the distance between the bases is called the altitude, of the frustum.

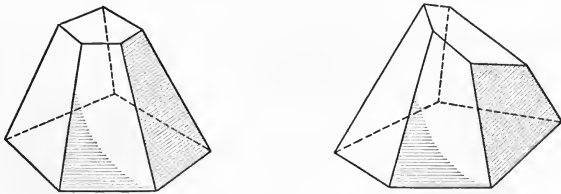

In case the cutting plane is not parallel to the base of the pyramid, but cuts all of the lateral edges, the solid obtained is called a *truncated pyramid*.

QUERY 1. Why are the bases of a frustum of a pyramid similar polygons?

QUERY 2. How many lateral faces of a truncated pyramid may be trapezoids?

QUERY 3. If a pyramid with a base a few inches on a side has its vertex 10 miles above the base, what would a frustum of the pyramid near the base resemble?

Theorem 16

522. *The volume of a frustum of a pyramid equals one third of the product of the altitude and sum of the upper base, the lower base, and the mean proportional between the two bases.*

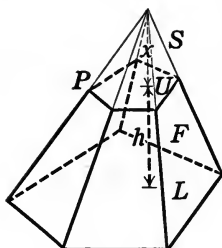

Given F , any frustum of a pyramid, with the upper base U , the lower base L , and the altitude h .

To prove that $\text{volume } F = \frac{1}{3} h (L + U + \sqrt{U \times L})$.

Proof. Construct the pyramid P , of which F is a frustum, and let its altitude be $h + x$. Denote by S the small pyramid which has U for a base and x for an altitude.

It is required to express F in terms of L , U , and h .

$$\begin{aligned} \text{Now } F = P - S &= \frac{1}{3} L(h + x) - \frac{1}{3} U \cdot x = \frac{1}{3} (hL + Lx - Ux) \\ &= \frac{1}{3} [hL + x(L - U)]. \end{aligned} \quad (1) \quad \S 520$$

We must now eliminate x , that is, express x in terms of L , U , and h , and substitute the value obtained in (1).

$$\text{Now} \quad \frac{x^2}{(x + h)^2} = \frac{U}{L}. \quad \S 517$$

Extracting the square root,

$$\frac{x}{x + h} = \frac{\sqrt{U}}{\sqrt{L}}.$$

Solving this equation for x ,

$$x = \frac{h \sqrt{U}}{\sqrt{L} - \sqrt{U}}.$$

Substituting in (1), we obtain

$$\begin{aligned}
 F &= \frac{1}{3} \left[hL + \frac{h\sqrt{U}(L-U)}{\sqrt{L}-\sqrt{U}} \right] \\
 &= \frac{1}{3} [hL + h\sqrt{U}(\sqrt{L} + \sqrt{U})] \\
 &\text{(since } L - U = (\sqrt{L} - \sqrt{U})(\sqrt{L} + \sqrt{U})\text{)} \\
 &= \frac{1}{3} (hL + h\sqrt{UL} + hU) \\
 &= \frac{1}{3} h(L + U + \sqrt{U \cdot L}).
 \end{aligned}$$

NOTE. The foregoing rule for the volume of the frustum of a pyramid was first given by Heron of Alexandria in substantially the same form as in this text. A Hindu mathematician named Brahmagupta (about 650) gave a rule for the volume of the frustum of a pyramid with square bases of sides S_1 and S_2 as follows:

$$V = \frac{1}{3}h(S_1^2 + S_2^2 + S_1S_2).$$

QUERY 1. A pyramid may be considered as a frustum of a pyramid with its upper base equal to zero. Verify the formula for the volume of a frustum of a pyramid in this case.

QUERY 2. Verify the formula for the frustum of a pyramid for the case where the upper base equals the lower base. What is a more familiar name for this solid?

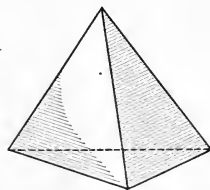

523. Tetrahedron. A polyhedron having four faces is called a *tetrahedron*. The terms *tetrahedron* and *triangular pyramid* are interchangeable.

Two skew edges of a tetrahedron are called opposite edges.

EXERCISES

93. If the base of a regular pyramid 10 feet high contains 16 square feet, what is its volume?

94. What is the volume of a square pyramid 12 feet high if the base is 6 feet on a side?

95. The base of a pyramid is an equilateral triangle 6 inches on a side, and its altitude is 8 inches. Find the volume.

96. What is the volume of the frustum of a pyramid whose bases are equilateral triangles, 3 feet and 6 feet on a side respectively, and whose altitude is 5 feet?

97. The altitude of a pyramid with a square base is 8 inches. The volume is 128 cubic inches. Find a side of the base.

98. The base of a pyramid is an isosceles triangle whose sides are 10, 10, and 6 inches. The altitude of the pyramid is 15 inches. Find the volume.

99. The sides of the base of a tetrahedron are 10, 17, and 21 inches, and its altitude is 6 inches. Find its volume.

100. The base of a pyramid is twice that of a section parallel to it and 3 feet above it. Find the altitude of the pyramid.

101. A pyramid is 18 inches in height. A section 1 foot from the base and parallel to it has an area of 56 square inches. Find the volume of the pyramid.

102. The base of a pyramid contains 64 square inches, and its altitude is 8 inches. How far from the vertex must a plane parallel to the base be passed in order to get a section one quarter of the area of the base?

103. A frustum of a pyramid whose square lower base is 40 feet on a side consists of earth which rests at an angle of 45° . How high is the frustum if the top contains 100 square feet? How many cubic feet are there in the frustum?

104. A miller wishes to make a hopper in the form of an inverted frustum of a square pyramid, with the bases 6 and 3 feet on a side, respectively. How deep shall he make it in order that it shall hold 15 bushels of grain? (A bushel = 1.24 cubic feet.)

105. Cleopatra's Needle, the Egyptian obelisk in New York City, consists of a frustum of a pyramid whose lower base is a square $7\frac{1}{2}$ feet on a side, whose upper base is 4 feet on a side, and whose altitude is 61 feet, surmounted by a pyramid whose base is the upper base of the frustum and whose altitude is $7\frac{1}{2}$ feet. Find the weight of the Needle in tons. (One cubic foot of the stone weighs about 170 pounds.)

524. Regular pyramid. A *regular pyramid* is one whose base is a regular polygon and whose vertex lies in the perpendicular erected at the center of the base.

(The center of a regular polygon is the center of its circumscribing circle.)

EXERCISE 106. Prove that the perpendicular from the vertex to the base of a regular pyramid passes through the center of the circle which circumscribes the base.

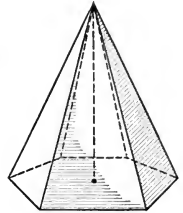

525. Regular tetrahedron. A regular triangular pyramid has an equilateral triangle as base (§ 524). Its altitude may have any length. There may be, therefore, any number of regular triangular pyramids on the same base. The regular triangular pyramid which has all its lateral faces equilateral triangles is called a *regular tetrahedron*.

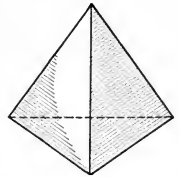

QUERY. Are the lateral faces of a regular tetrahedron congruent to the base?

Prove each of the following propositions concerning a regular pyramid:

526. *The lateral edges of a regular pyramid are equal.*

527. *The lateral faces of a regular pyramid are congruent isosceles triangles.*

528. *The altitudes of the lateral faces of a regular pyramid are equal.*

529. *If a regular pyramid is cut by a plane parallel to its base, the pyramid cut off has equal lateral edges.*

530. Slant height. The *slant height* of a regular pyramid is the altitude of any of its lateral faces.

Theorem 17

531. *The lateral area of a regular pyramid equals the product of one half the perimeter of the base and the slant height.*

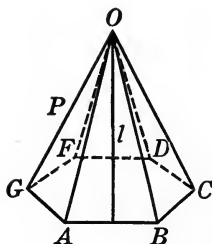

Given any regular pyramid P , with the base $ABCDFG$ and the slant height l .

To prove lateral area of $P = \frac{1}{2} l \cdot \text{perimeter } ABCDFG$.

Proof. Area of face $OAB = \frac{1}{2} l \cdot AB$. § 320

Area of face $OBC = \frac{1}{2} l \cdot BC$. § 528

.

Adding and factoring,

$$\text{Area}(OAB + OBC + \dots) = \frac{1}{2} l (AB + BC + \dots),$$

$$\text{or lateral area } P = \frac{1}{2} l \cdot \text{perimeter } ABCDFG.$$

QUERY 1. Does a pyramid which is not regular have any slant height? How could its lateral area be found?

QUERY 2. If two regular pyramids, one having a square base and the other having a hexagonal base, have equal altitudes, and if their bases are inscribed in the same circle, which one has the greater slant height?

QUERY 3. If two regular pyramids have equal altitudes, and bases of equal area but of different numbers of sides, are their lateral areas equal? Discuss completely.

QUERY 4. If two pyramids have equal lateral areas, are their volumes necessarily equal?

QUERY 5. Can a pyramid with very small lateral area have a great volume? Can one with a small volume have a great lateral area?

Theorem 18

532. *The lateral faces of a frustum of a regular pyramid are congruent trapezoids.*

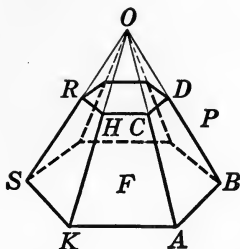

Given a frustum F of a regular pyramid, and let $ABDC$ and $SKHR$ be any two lateral faces.

To prove that $ABDC$ and $SKHR$ are congruent trapezoids.

Proof. RH is \parallel to SK and CD is \parallel to AB . Why?

Hence $ABDC$ and $SKHR$ are trapezoids. § 107

Let O be the vertex of the pyramid.

To prove $ABDC$ and $KACH$ congruent, fold over OAK on OA as axis, so that it coincides with OAB . § 20

Then AK coincides with AB , §§ 79, 527

and therefore CH coincides with CD . § 45

Therefore $ABDC$ and $KACH$ coincide throughout.

Similarly, any lateral face can be proved congruent to an adjacent one, and hence to any lateral face of the frustum. § 32 (2)

533. Slant height of frustum. *The slant height of a frustum of a regular pyramid is the altitude of any of its faces.*

QUERY 1. Would a truncated pyramid have any slant height?

QUERY 2. Would the frustum of a pyramid which is not regular have any slant height?

Theorem 19

534. *The lateral area of the frustum of a regular pyramid is equal to one half the product of the sum of the perimeters of the bases and the slant height.*

Proof is left to the student.

EXERCISES

107. The lateral area of a pyramid is greater than the area of its base.

108. If the regular tetrahedron of the adjacent figure has an edge 6 inches long, compute the lines AL , KL , AR , and KR , where L is the mid-point of CB and KR is the altitude of the tetrahedron.

HINT. See Exercise 106, page 399.

109. If the frustum of a regular pyramid in the adjacent figure has slant height 10 and sides of the bases 24 and 12 respectively, compute RA , KA , AL , where KR is the slant height and KA the altitude of the frustum.

In Exercises 110–116, all of which relate to pyramids, h denotes the altitude, B the area of the base, b one side of the base, n the number of sides of the base, l the slant height, S the lateral area, and V the volume.

110. Given $V = 46$, $h = 113/4$. Find B .

111. Given $B = 12$, $h = 15$. Find V .

In Exercises 112–116 the pyramid is regular.

112. Given $b = 6$, $n = 4$, $h = 4$. Find S .

113. Given $V = 25$, $h = 3$, $n = 4$. Find S .

114. Given $S = 100$, $b = 4$, $n = 5$. Find l .

115. Given $l = 4$, $n = 3$, $b = 6$. Find h .

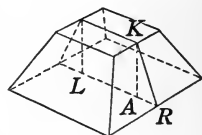
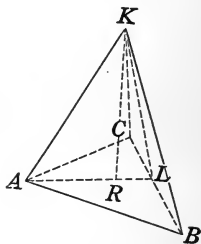

116. Given $n = 3$, $B = 16$, $l = 5$. Find V .

117. The area of the base of a regular quadrangular pyramid is 36 square inches. A lateral edge is 10 inches. Find (1) the lateral area, (2) the volume.

118. One side of the base of a regular tetrahedron is 8 feet. Find the lateral area.

119. The frustum of a regular quadrangular pyramid has bases with edges 12 and 18 respectively. Its altitude is 4. Find the lateral area.

120. The frustum of a regular triangular pyramid has bases with sides 6 and 12 inches respectively, and an altitude of 4 inches. Find the lateral area.

121. A regular quadrangular pyramid has an altitude of 12 feet, and a base 24 feet on a side. Find the angle between a face and the base.

122. A regular quadrangular pyramid has a base 6 inches on a side, and a lateral face makes an angle of 60° with the base. Find (1) the lateral area, (2) the volume.

123. It is desired to make a regular triangular pyramid equal in volume and altitude to a given regular hexagonal pyramid whose base is 6 feet on a side. How long is a side of the base of the new pyramid?

124. The bases of a frustum of a regular pyramid are equilateral triangles whose sides are 4 and 6 inches respectively. The slant height of the frustum is 12 inches. Find (1) the lateral area and (2) the total area of the frustum.

125. Prove that the altitude of a regular tetrahedron is $\frac{1}{3}\sqrt{6}$ times the edge.

HINT. The altitude meets the base at the intersection of its medians.

126. Prove that for a regular tetrahedron whose edge is a the volume is equal to $\frac{a^3\sqrt{2}}{12}$.

127. If the base of a pyramid is a parallelogram, and the section made by a plane not parallel to the base has one side parallel to one side of the base, prove that the section is a trapezoid.

128. If each pair of opposite edges of a given tetrahedron are equal, and the surface of the tetrahedron is cut along three concurrent edges and opened out flat, prove that the figure formed is a triangle.

129. How many right angles in the sum of the angles of all the faces of a pyramid whose base has n sides?

130. In a tetrahedron $O-ABC$ the points P, R, S, T , which bisect the edges OA, OB, BC, AC , are coplanar.

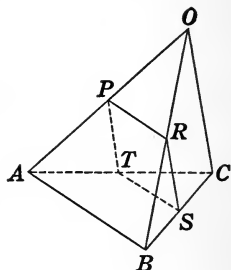

131. In a tetrahedron, if a plane is passed parallel to two opposite edges, the section is a parallelogram.

132. In the tetrahedron $O-ABC$ let D and F be the points where the medians of the faces OBC and ABC respectively meet. Prove (1) that the lines AD and OF meet, (2) that the triangle ROA is similar to RFD .

133. Prove that the three lines drawn from the vertices of a tetrahedron to the intersections of the medians of the opposite faces meet in a point which divides each of the lines in the ratio 3:1.

These lines are called the *medians* of the tetrahedron.

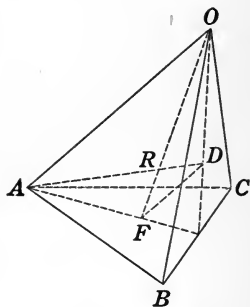

NOTE. The point located in Exercise 133 is called the center of gravity of the tetrahedron. It is the point about which the solid would exactly balance if it could be supported at that point. It is interesting to note that the center of gravity of a triangle divides the medians in the ratio 2:1, while that of the tetrahedron divides the medians in the ratio 3:1.

CONES

535. Conical surface. A *conical surface* is generated by a moving line which always passes through a given fixed point and continually intersects a given fixed curve.

The fixed point is called the *vertex*, the fixed curve the *directrix*, and the moving line the *generator*, of the conical surface.

The surface consists of two parts, or *nappes*, connected only at the vertex.

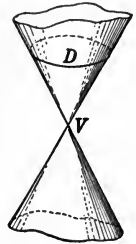

536. Cone. The solid bounded by a conical surface and a plane whose section with the surface is a closed curve is called a *cone*.

In this text only convex cones, that is, cones whose directrices are convex curves, are treated.

The terms *base*, *altitude*, and *frustum* are defined similarly to the corresponding terms applied to the pyramid.

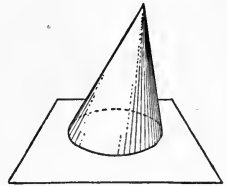

537. Element. The generator of a conical surface in any of its positions is called an *element* of the conical surface.

There is one and only one element containing the vertex and a given point of the directrix.

538. Element of a cone. The segment of the element of a conical surface included between the vertex of the cone and the base is called an *element of the cone*.

QUERY 1. What kind of surface would be generated if the vertex and the directrix of a conical surface were in the same plane?

QUERY 2. What is the locus of lines through a given point which make a given angle with a given plane?

QUERY 3. What is the locus of lines making a given angle with a given plane at a given point? What if the given angle is 90° ?

QUERY 4. Define base, altitude, and frustum as applied to the cone.

Theorem 20

539. *If one of two parallel planes intersects a conical surface in a circle, the other does also, and the vertex of the conical surface is in a straight line with the centers of the two circles.*

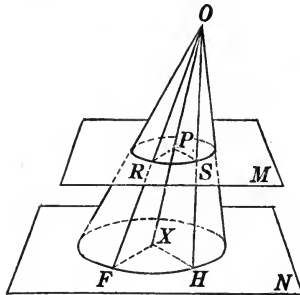

Given a conical surface with vertex O cut by the two parallel planes M and N . Let the intersection with N be a circle with center X . Let OX intersect N at the point P .

To prove that the section with M is a circle whose center is P .

Proof. Let OF and OH be the elements through any two points R and S respectively on the section. Pass planes determined by XO and FO , and by XO and HO , intersecting N in XF and XH , and M in PR and PS , respectively.

XF is \parallel to PR ; XH is \parallel to PS . Why?

$$\frac{PS}{XH} = \frac{OP}{OX}; \quad \frac{PR}{XF} = \frac{OP}{OX}. \quad \text{\S\S 271, 269}$$

Therefore $\frac{PS}{XH} = \frac{PR}{XF}$. Why?

But $XH = XF$. Why?

Therefore $PS = PR$. Why?

But R and S were any points on the section.

Therefore the section is circular, with P as its center. Why?

540. Corollary. *If either base of a frustum of a cone is circular, both bases are circular.*

NOTE. It appears from Theorem 20 that if a plane intersects a conical surface in a circle, all the planes which are parallel to it also cut the surface in circles. All other planes cut the surface in curves which are called conic sections. The names of these conic sections are the ellipse, the hyperbola, and the parabola.

Of these the ellipse is closed, while the others are open curves. If the cutting plane is not quite parallel to the circular base of the

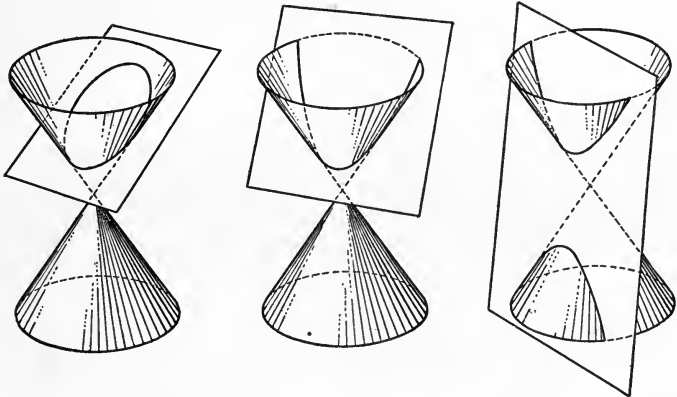

cone, the section is a closed curve a little longer in one direction than in another. If the plane is passed near the vertex, and barely cutting all the elements, a very narrow closed curve is obtained. Any one of the closed sections of a conical surface whose directrix is a circle is called an *ellipse*, except, of course, those that are circular.

If the cutting plane is parallel to one of the elements, it cuts all the elements except this one, and hence is an open curve, called a *parabola*.

If the plane cuts both nappes of the conical surface, making a curve with two separate branches, it is called a *hyperbola*.

The Greeks studied the properties of all the conic sections by methods similar to those of this text, and derived many important properties. These results were regarded as mathematical curiosities without any application to nature until Kepler (1571-1630) discovered that the planets move around the sun in ellipses, and that the properties

of the curves discovered so long before were useful in explaining their motions.

Since the time of Kepler thousands of applications of the properties of the conic sections have been discovered in all branches of science, and a thorough knowledge of them is an important part of the equipment of the modern scientist. This is acquired nowadays most effectively through the study of analytic geometry, a branch of mathematics whose early development was due to the French philosopher Descartes (1596-1650). The fundamental ideas of analytics are now usually taught in connection with algebra and are included in the work on graphs. But the complete elaboration of the subject includes extensive studies of all kinds of curves and surfaces, of which the simplest and the most useful are the conic sections.

541. Circular Cone. A *circular cone* is one which has a circular section such that the line joining the vertex of the cone to the center of the circle is perpendicular to the plane of the circle.

A circular cone does not necessarily have a circular base.

In the adjacent figure the plane M makes a circular section of the cone of which T is the center, and OT is perpendicular to M .

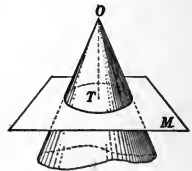

542. Right circular cone. A *right circular cone* is a circular cone with a circular base.

543. Axis. The line joining the vertex of a right circular cone with the center of its base is called the *axis* of the cone.

544. Corollary. *The elements of a right circular cone are equal.*

HINT. Apply § 425.

545. Slant height. The length of an element of a right circular cone is called its *slant height*.



Theorem 21

546. *The section of a cone made by a plane which passes through the vertex and cuts the base is a triangle.*

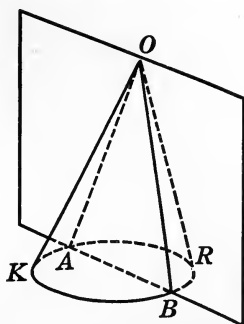

Given any cone $O-KR$, and a plane which contains the vertex and cuts the base in AB .

To prove that the section OAB is a triangle.

Proof. AB is a straight line. Why?

The straight line joining O and A lies in the given plane § 381
and also in the conical surface. § 535

Therefore the intersection OA is this straight line. § 390

Similarly, OB is a straight line.

Therefore the section AOB is a triangle. § 16

547. Inscribed pyramid. A pyramid whose base is inscribed in the base of a given cone, and whose vertex is the vertex of the cone, is said to be *inscribed* in the cone.

QUERY 1. If the vertex of a cone is remote from the base, a frustum of the cone near the base resembles what solid?

QUERY 2. To what theorem regarding the cylinder does Theorem 21 correspond?

QUERY 3. Why will the lateral edges of an inscribed pyramid be elements of the cone?

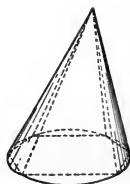

QUERY 4. Will the slant height of an inscribed pyramid ever be equal to an element of the cone?

QUERY 5. Which will be greater, the slant height of a regular triangular pyramid or that of a quadrangular pyramid, if both are inscribed in the same cone?

QUERY 6. If a pyramid is inscribed in a right circular cone, what kind of triangles form its lateral faces?

QUERY 7. Will the altitudes of all the triangles mentioned in Query 6 necessarily be equal?

EXERCISES

134. Construct a regular hexagonal pyramid inscribed in a right circular cone, giving a reason for each step.

135. Given a right circular cone with altitude 8 and radius 6, find the following for the inscribed regular quadrangular pyramid: (1) area of base, (2) slant height, (3) volume, (4) lateral area.

136. Find the parts required in Exercise 135 for a regular hexagonal pyramid inscribed in the same cone.

548. Volume of cone. If the base of a pyramid which is inscribed in a cone has a very large number of sides, so that each side is very short, then the area of the base of the pyramid is approximately equal to the area of the base of the cone. By taking the sides sufficiently short, thereby increasing their number, as close an approximation as desired may be obtained.

The volume of the inscribed pyramid whose base is almost the same in area as that of the circumscribed cone will differ very little from that of the cone. But the volume of the pyramid is one third the product of its base and altitude, however many lateral faces it may have. Since the volume, and the area of the base, of the cone can be made to differ as little as we may desire from the same features of the pyramid, and since their altitudes are identical, we shall make the statements of theorems 22, 23, and 24 without proof. They can be rigorously demonstrated by the theory of limits.

Theorem 22

549. *The volume of a cone is equal to one third the product of the area of its base and its altitude.*

550. **Corollary.** *The volume, V , of a cone with a circular base is*

$$V = \frac{1}{3} \pi r^2 h,$$

where r is the radius of the base and h is the altitude of the cone.

Theorem 23

551. *The volume, V , of a frustum of a cone is*

$$V = \frac{1}{3} h (L + U + \sqrt{L \times U}),$$

where h is the altitude and L and U the areas of the lower and upper bases respectively of the frustum.

552. **Corollary.** *The volume, V , of a frustum of a circular cone is*

$$V = \frac{1}{3} \pi h (r^2 + r_1^2 + rr_1),$$

where h is the altitude and r and r_1 are the radii of the lower and upper bases respectively of the frustum.

HINT. Apply § 551.

Theorem 24

553. *The volumes of two prisms, cylinders, pyramids, or cones*

(1) *are to each other as the products of their bases and altitudes ;*

(2) *having equal bases are to each other as their altitudes ;*

(3) *having equal altitudes are to each other as their bases.*

HINT. Denote the altitude by h and the base by B for each solid, and use the appropriate formula for the volume.

QUERY 1. What is the ratio of the volume of a cylinder to that of a cone with the same base and altitude ?

QUERY 2. If two cones have equal bases and equal slant heights, are their volumes necessarily equal?

QUERY 3. What is the locus of the vertices of cones which have the same base and equal altitudes?

QUERY 4. Does every cone have a slant height? Explain.

EXERCISES

137. The altitude of a right circular cone is 16 feet, and its slant height is 29 feet. Find its volume.

138. What is the radius of the base of a circular cone whose volume is 100 cubic inches and whose altitude is 5 inches?

139. The radius of a right circular cone is 6 inches. Find the area of the section formed by a plane containing the axis of the cone if the element is 12 inches long.

140. A right circular cone with altitude 10 inches and radius 6 inches is cut by a plane through the vertex so as to make a section having an area just half as great as that of the greatest triangular section. How far from the center of the base is the intersection of this plane with the base?

141. The frustum of a right circular cone has an altitude of 12 inches and radii of 4 and 6 inches respectively. Find its volume.

142. The slant height of a frustum of a right circular cone is 20 feet. The radii are 2 and 8 feet respectively. Find the volume.

554. **Lateral area of a cone.** The *lateral area* of a cone is the area of the conical surface of the cone.

We cannot conveniently apply the unit of area to such a curved surface as a conical surface so as to estimate the number of times it is contained in the surface. Yet the fact that some number exists which tells how many times the unit area is contained in the conical surface is so clear that no one but a student of advanced mathematics would ever think of requiring a proof of the statement. Such discussions would be out of place here.

Since the lateral area of a regular pyramid equals one half the product of its slant height and the perimeter of its base, whether there are few or many lateral faces, and since, when the lateral faces become very numerous and at the same time very narrow, the lateral area, the perimeter of the base, and the slant height, of a regular pyramid inscribed in a right circular cone are approximately equal to the same features of the cone, we may make the following statements, which will be assumed without proof.

Theorem 25

555. *The lateral area of a right circular cone is equal to one half the product of the perimeter of the base and the slant height.*

Expressed in symbols,

$$S = \frac{2\pi r l}{2} = \pi r l,$$

where S is the lateral area, r is the radius, and l is the slant height, of the cone.

NOTE. The student can further convince himself of the truth of this formula by rolling about its vertex and on a plane surface a right circular cone which rests on one of its elements. If the cone is rolled continuously in the same direction until the element comes in contact

with the surface for the second time, it will appear that the part of the plane with which the cone has come in contact is a sector of a

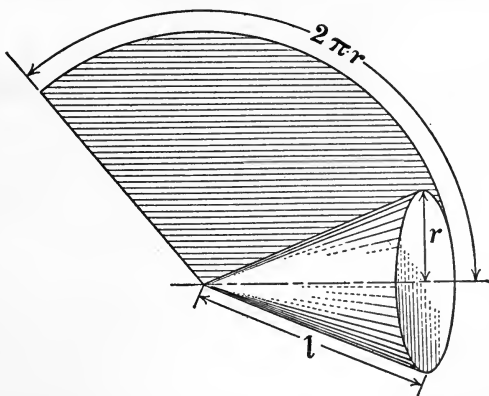

circle the arc of which equals $2\pi r$, the perimeter of the base of the cone, and the radius of which equals l , the slant height of the cone.

Now the area of this sector equals one half of the product of the arc which forms its base, $2\pi r$, and the radius, l , of the circle (§ 369). Here again we have

$$S = \frac{2\pi r \cdot l}{2} = \pi r l.$$

556. Corollary. *The lateral area of a right circular cone is equal to the product of the slant height and the perimeter of the circle halfway between the base and the vertex.*

557. Lateral area of frustum of cone. Since the lateral area of the frustum of a regular pyramid equals one half the product of the sum of the perimeters of the bases and the slant height, whether there are few or many equal isosceles trapezoids as lateral faces, and since, when these trapezoids become very numerous and at the same time very narrow, the lateral area, the perimeter of the base, and the slant height of the frustum of a regular pyramid inscribed in the frustum of a right circular cone are approximately equal to the same features of the frustum of the cone, we may assume the following:

Theorem 26

558. *The lateral area of a frustum of a right circular cone is equal to one half the product of the sum of the perimeters of the bases times the slant height.*

Expressed in symbols,

$$S = \frac{l(2\pi r + 2\pi r_1)}{2} = \pi l(r + r_1),$$

where S is the lateral area, l the slant height, r and r_1 the radii of the bases of the frustum.

NOTE. Rolling a frustum of a cone in the manner described in the preceding note shows that the lateral area of the frustum equals an incomplete sector of a circle.

Let x denote the portion of the slant height between the upper base of the frustum and the vertex of the completed cone.

Then
$$\frac{r}{r_1} = \frac{l+x}{x}. \tag{1}$$

Area rolled out = $\pi r(l+x) - \pi r_1 x = \pi r l + \pi r x - \pi r_1 x. \tag{2}$

From (1), $rx = r_1 l + r_1 x.$

Substituting in (2) we obtain,

area of frustum = $\pi r l + \pi r_1 l = \pi l(r + r_1).$

Hence $S = \pi l(r + r_1).$

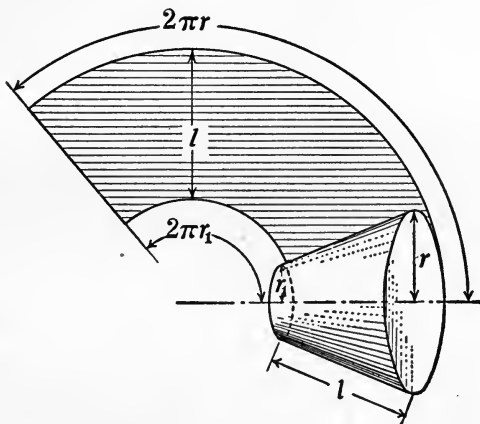

559. Corollary. *The lateral area of a frustum of a right circular cone is equal to the product of the slant height by the perimeter of a circle halfway between the bases.*

QUERY. How do you interpret the formulæ for the volume and the lateral area of a frustum of a cone when $r = 0$; when $r = r_1$?

EXERCISES

143. A right circular cone is 14 inches high and has a radius of 5 inches. Find its lateral area.

144. A frustum of a right circular cone is 10 inches high, and its radii are 4 and 6 respectively. Find the total area.

145. A tent of radius 16 feet and 14 feet high is in the form of a cylinder surmounted by a cone. The height of the conical part is 8 feet. Find the number of square yards in the surface of the tent.

146. Find the lateral area and the total area of a right circular cone whose volume is 24π cubic feet and whose radius is 3 feet.

147. Prove that the areas of circular sections of a cone made by parallel planes are proportional to the squares of the distances of their planes from the vertex.

148. The radii of circular sections of a cone made by parallel planes are proportional to their distances from the vertex.

Theorem 27

560. *A right circular cone is generated by the revolution of a right triangle about one of its sides as an axis.*

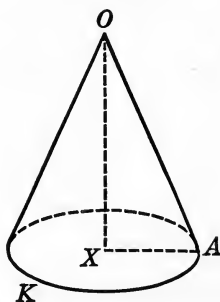

Given any right triangle XOA revolving about the side OX as an axis and generating the figure OAK .

To prove that OAK is a right circular cone.

Proof. XA generates a plane \perp to XO at X . Why?

A generates a circle with center at X . Why?

OA generates a conical surface. § 535

Therefore XOA generates a right circular cone. § 542

561. Cone of revolution. In accordance with Theorem 27, a right circular cone is frequently called a *cone of revolution*.

562. Similar cones. Two cones of revolution which are generated by similar right triangles with corresponding sides as axes are *similar cones of revolution*.

QUERY 1. Would two cones of revolution ever be similar if they were formed by the revolution of similar triangles about sides that were not corresponding?

QUERY 2. Would a cone of revolution be formed by the revolution of a triangle about its altitude as an axis?

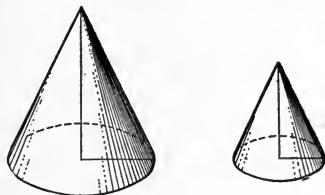

Theorem 28

563. *If two cones of revolution are similar,*

(1) *their volumes are proportional to the cubes of their altitudes, of their radii, or of their slant heights ;*

(2) *the lateral areas or the total areas are proportional to the squares of their altitudes, of their radii, or of their slant heights.*

Let V , S , T , h , r , and l stand for volume, lateral area, total area, altitude, radius, and slant height, respectively. Then

$$\frac{V}{V_1} = \frac{h^3}{h_1^3} = \frac{r^3}{r_1^3} = \frac{l^3}{l_1^3} \text{ and } \frac{S}{S_1} = \frac{T}{T_1} = \frac{h^2}{h_1^2} = \frac{r^2}{r_1^2} = \frac{l^2}{l_1^2}.$$

The proof, which is left to the student, is similar to that of Theorem 10.

564. Tangent plane to a cone. A *tangent plane* to a cone is one which meets the cone only along an element.

A tangent plane to a cone is determined by a tangent to the base of the cone and the element drawn to the point of contact.

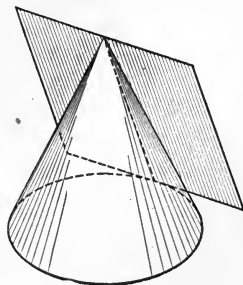

565. Circumscribed pyramid. A pyramid is said to be *circumscribed* about a cone when its base is circumscribed about that of the cone and its lateral faces are tangent to the cone.

QUERY 1. What point do all the tangent planes to a cone have in common?

QUERY 2. How many planes tangent to a given circular cone can be passed through a given exterior point?

QUERY 3. Can a right triangle be found which will generate any given right circular cone?

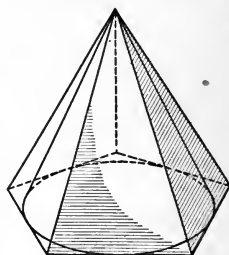

QUERY 4. What does a right triangle generate when revolved about its hypotenuse?

QUERY 5. Describe the solid generated by the revolution of an obtuse triangle about one side of the obtuse angle.

QUERY 6. Describe the solid generated by an isosceles trapezoid when revolved about (1) the line joining the mid-points of the parallel sides, (2) the longer parallel side, (3) the shorter parallel side.

QUERY 7. What does a square generate when revolved about a diagonal?

QUERY 8. What does a rectangle generate when revolved about an axis parallel to one of the sides of the rectangle and in its plane but lying entirely outside the rectangle?

QUERY 9. Similar polyhedrons have not yet been defined in this text. But from analogy with the ratio of the areas of similar polygons, and with the results of Theorems 10 and 28 in mind, what do you think the ratio of the volumes of similar polyhedrons probably is?

EXERCISES

In Exercises 149-157, which refer to cones of revolution, h represents the altitude, r the radius of the base, l the slant height, S the lateral area, T the total area, and V the volume.

149. Given $r = 5\frac{1}{3}$, $h = 8\frac{1}{2}$. Find V .

150. Given $r = 6$, $l = 5$. Find S .

151. Given $r = 5$, $l = 8$. Find V .

152. Given $l = 6$, $S = 132$. Find T .

153. Given $T = 55$, $r = 3$. Find S .

154. Given $V = 110$, $r = 4$. Find S .

155. Given $T = 2S$, $r = 5$. Find V .

156. Given $V = S$, $l = 4$. Find V .

157. Given $l = 2r$, $h = 2\sqrt{3}$. Find T .

158. The sides of a right triangle are 6, 8, and 10 inches. Find (1) the volume, (2) the lateral area, and (3) the total area of the cone generated by revolving the triangle about its shortest side.

159. The triangle of Exercise 158 is revolved about the side 8. Find (1) the volume, (2) the lateral area, and (3) the total area, and compare these values with the results of Exercise 158.

160. Find (1) the volume and (2) the area of the solid formed by the rotation of an equilateral triangle about one of its altitudes.

161. The parallel sides of an isosceles trapezoid are 12 and 18 inches respectively. The altitude is 4 inches. Find (1) the volume, (2) the area of the solid obtained by rotating it about the longer of the parallel sides.

162. What is the area of the largest section which can be made by a plane through the vertex of a right circular cone whose altitude is 10 inches and whose radius is 6 inches.

163. Prove that a cone circumscribed about a regular pyramid is a cone of revolution.

POLYHEDRONS

566. **Polyhedral angle.** The figure formed at the vertex of a pyramid by one nappe of a pyramidal surface (see § 513) is called a *polyhedral angle*.

The principal distinction between the polyhedral angle and the pyramidal surface lies in the fact that in the former we fix the attention on the portion of the figure near the vertex.

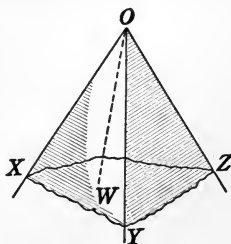

The terms *face*, *edge*, *vertex*, and *dihedral angle* are applied to the parts of the polyhedral angle in the same sense as they are applied to the parts of a pyramidal surface.

567. The angle between two edges of a polyhedral angle is called a *face angle*.

568. Trihedral angle. A polyhedral angle which has only three faces is called a *trihedral angle*.

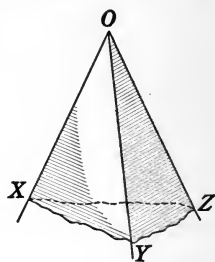

Theorem 29

569. *If two trihedral angles have their face angles equal and arranged in the same order, the corresponding dihedral angles are equal.*

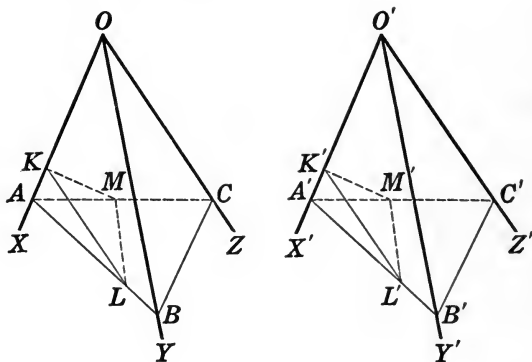

Given any trihedral angles O and O' , in which the face angle XOY equals $X'O'Y'$, YOZ equals $Y'O'Z'$, ZOX equals $Z'O'X'$.

To prove the dihedrals $OX = O'X'$, $OY = O'Y'$, $OZ = O'Z'$.

Proof. Lay off OA, OB, OC , equal respectively to $O'A', O'B', O'C'$.

Pass planes through ABC and $A'B'C'$.

Lay off AK equal to $A'K'$, and pass KLM and $K'L'M' \perp$ respectively to OA and $O'A'$.

AK is \perp to KL and KM , while $A'K'$ is \perp to $K'L'$ and $K'M'$. § 414

Hence the angles LKM and $L'K'M'$ are plane \sphericalangle s of dihedrals OA and $O'A'$ respectively. § 432

We shall prove the plane angles equal by proving $\triangle LKM$ congruent to $\triangle L'K'M'$.

$\triangle AOB$ is congruent to $\triangle A'O'B'$. § 25

Hence $\angle KAL = \angle K'A'L'$. Why?

Therefore right $\triangle AKL$ is congruent to right $\triangle A'K'L'$. Why?

Similarly, $\triangle AKM$ is congruent to $\triangle A'K'M'$.

Hence $KL = K'L'$ and $KM = K'M'$. § 27

It remains to show that $LM = L'M'$.

Now $AB = A'B'$. Why?

Similarly, $BC = B'C'$ and $CA = C'A'$.

Hence $\triangle ABC$ is congruent to $\triangle A'B'C'$. Why?

and $\angle CAB = \angle C'A'B'$. Why?

Furthermore, $AL = A'L'$ and $AM = A'M'$. Why?

Therefore $\triangle MAL$ is congruent to $\triangle M'A'L'$. § 27

and $LM = L'M'$. Why?

Hence $\triangle LKM$ is congruent to $\triangle L'K'M'$. Why?

and $\angle LKM = \angle L'K'M'$. Why?

Therefore dihedral $AO =$ dihedral $A'O'$. Why?

After similar constructions on the other edges of the trihedral it can be proved by the method just employed that dihedrals OB and $OC =$ dihedrals $O'B'$ and $O'C'$ respectively.

Hence the three dihedrals of one trihedral angle are equal respectively to the three corresponding dihedrals of the other.

EXERCISES

164. If the face angles of two trihedrals are equal each to each and are arranged in the same order, the trihedrals are congruent.

165. If two trihedral angles have a face angle of one equal to a face angle of the other, and the corresponding adjacent dihedrals equal, prove by superposition that the trihedrals are congruent.

166. If the edges of two trihedral angles are parallel each to each and extend in the same directions from the vertices, the dihedrals are congruent.

QUERY 1. Can each of three planes meet the other two without forming a trihedral angle?

QUERY 2. How small may the sum of the face angles of a trihedral angle be? How large?

QUERY 3. How does a trihedral angle look if the sum of its dihedral angles is nearly equal to six right angles? How if the sum of its dihedral angles is nearly as small as two right angles?

QUERY 4. Referring to the propositions proved in Plane Geometry, it appears that Theorem 29 and Exercise 165 above correspond to § 33 and § 82, respectively, of the Plane Geometry if we relate the face angles and dihedrals of the trihedral to the sides and angles of the triangle respectively.

Read the list of theorems proved in Plane Geometry regarding the triangle, and state those to which you think a corresponding theorem for trihedral angles seems likely to be true. Consider, for example, §§ 25, 29, and 66.

QUERY 5. If isosceles trihedral angles are defined as those, two of whose face angles are equal, study the correspondence between the theorems on isosceles triangles and isosceles trihedrals.

NOTE. In plane geometry, if two triangles have three angles of one equal respectively to three angles of the other, the triangles are not congruent but merely similar. The corresponding problem relating to trihedral angles would be that of finding the relation between two trihedrals whose dihedrals are respectively equal. As a matter of fact such trihedrals are congruent, not similar, as one would expect from plane geometry. This fact cannot be proved simply until a little later, in connection with our study of the sphere.

Theorem 30

570. *The sum of two face angles of a trihedral angle is greater than the third.*

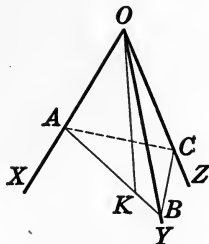

Given any trihedral angle $O\text{-}XYZ$.

To prove that $\angle ZOY + \angle XOZ > \angle XOY$.

Proof. There is no necessity for proof if either XOZ or ZOY is greater than or equal to XOY .

In the face XOY draw OK , making the $\angle XOK = \angle XOZ$.

On OZ lay off $OC = OK$.

Through K and C pass a plane which does not contain O , as ABC .

In $\triangle OAK$ and OAC ,

$$AO = AO, OK = OC, \angle AOK = \angle AOC. \quad \text{Why?}$$

Hence $\triangle AOK$ is congruent to $\triangle AOC$. Why?

Therefore $AK = AC$.

In $\triangle ABC$, $AC + BC > AK + KB$. § 146

Subtracting the equals AC and AK , we have $BC > KB$. § 139

In the $\triangle OKB$ and OBC , $OK = OC$, $OB = OB$, $CB > KB$.

Therefore $\angle BOC > \angle KOB$. § 151

Hence, adding to this inequality the equal angles AOC and AOK , we have $\angle AOC + \angle BOC > \angle AOK + \angle KOB$. § 139

571. *Corollary.* Any face angle of a polyhedral angle is less than the sum of the remaining face angles.

Theorem 31

572. *The sum of the face angles of any convex polyhedral angle is less than four right angles.*

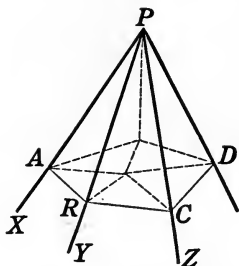

Given any polyhedral angle P with face angles $XPY, YPZ, \text{etc.}$

To prove that $XPY + YPZ + \dots < 4$ right angles.

Proof. Pass a plane forming the section $ARCD$.

Let the sum of the face angles of P be denoted by F .

Let the sum of the remaining angles in the lateral faces, as $ARP, PRC, \text{etc.}$, be denoted by L .

Let the sum of the angles of the polygon $ARCD$ be denoted by S .

Then if the polyhedral angle has n faces,

$$F + L = 2n \text{ rt. } \sphericalangle. \quad (1) \quad \S 66$$

$$\text{Also} \quad S = (2n - 4) \text{ rt. } \sphericalangle. \quad (2) \quad \S 125$$

$$\text{Now} \quad ARP + PRC > ARC. \quad \S 570$$

Since a similar inequality holds at each vertex of the polygon $A-D$, we have

$$L > S. \quad \S 141$$

$$\text{Hence} \quad L > (2n - 4) \text{ rt. } \sphericalangle. \quad (3)$$

Subtracting (3) from (1),

$$F < 4 \text{ right angles.} \quad \S 142$$

573. Regular polyhedron. A convex polyhedron is said to be *regular* if its faces are all congruent regular polygons and its polyhedral angles are all congruent.

Theorem 32

574. *No more than five regular polyhedrons are possible.*

Proof. Each of the polyhedral angles of a regular convex polyhedron is included by three or more faces which are regular polygons. Consider in turn the possibilities when the faces are (1) equilateral triangles, (2) squares, (3) pentagons, (4) hexagons.

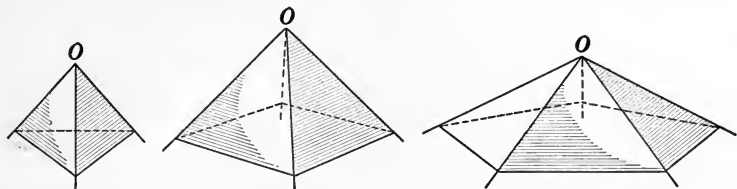

(1) Each angle of an equilateral triangle contains 60° . Hence there may be convex polyhedral angles with three, four, or five such faces, but not with six or more. § 572

Hence there can be no more than three regular polyhedrons with triangular faces.

(2) Each angle of a square contains 90° . There may be convex polyhedral angles with three square faces, but not with four or more.

Hence there can be no more than one regular polyhedron with square faces.

(3) Each angle of a regular pentagon contains 108° . Hence there may be convex polyhedral angles with three pentagons for faces but not with four or more. Why?

Hence there can be no more than one regular polyhedron with pentagonal faces.

(4) Each angle of a hexagon contains 120° .

Hence there can be no regular polyhedrons with hexagonal sides.

In the case of polygons of more than six sides, no polyhedral angle can be formed. Why?

Therefore no more than five regular polyhedrons are possible.

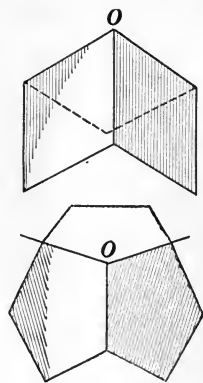

575. The five regular bodies. It does not follow from the foregoing theorem that there are necessarily five regular polyhedrons, but merely that this is the maximum possible number. In order to show the existence of polyhedrons of the various kinds it is necessary to prove the possibility of constructing each type. As a matter of fact, each of the five cases referred to in Theorem 32 does actually correspond to a regular polyhedron, as shown in the following diagrams:

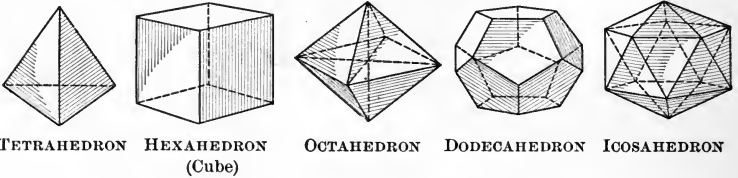

NOTE. The names of the regular polyhedrons are derived from the Greek words for four, six, eight, twelve, and twenty respectively, which reference to the diagrams will show to be the numbers of the faces of the various polyhedrons.

Construction 1

576. *Construct a regular tetrahedron.*

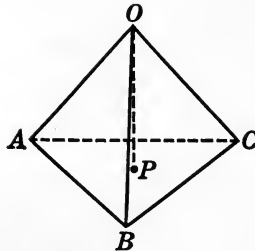

Construction. Construct an equilateral $\triangle ABC$, and find its center, P .

At P construct a line \perp to the plane of ABC . § 420

With a vertex of ABC as center, and a side of ABC as radius, determine O , in this \perp , so that $AO = AB$.

Draw OA, OB, OC .

Then $OABC$ is a regular tetrahedron.

Proof. $OA = OB = OC$. § 425

But $AB = AO$. Const.

Hence AOB is an equilateral Δ .

Similarly, the other faces are equilateral Δ .

Therefore all the trihedral \sphericalangle s are congruent. § 569

Hence the tetrahedron is regular. § 573

Construction 2

577. Construct a regular hexahedron, or cube.

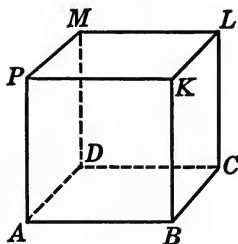

Construction. Construct a square, $ABCD$, and at each of the four vertices erect lines \perp to the plane of the square. § 420

Lay off along these \perp s $AP = BK = CL = DM$, each = AB .

Pass planes PKB, KLC, LMD , and MPA . § 385

Through P pass a plane \parallel to AC . § 408

The resulting figure is a cube,

Proof is left to the student.

Construction 3

578. *Construct a regular octahedron.*

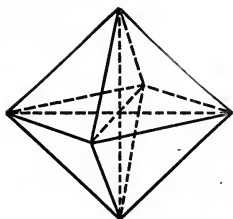

The **Construction** and **Proof** are left to the student.

HINT. Construct two square regular pyramids having the same base, with vertices on opposite sides of the base and with lateral edges equal to the sides of the base.

NOTE. The constructions of the dodecahedron and icosahedron are much more complicated and will not be given here.

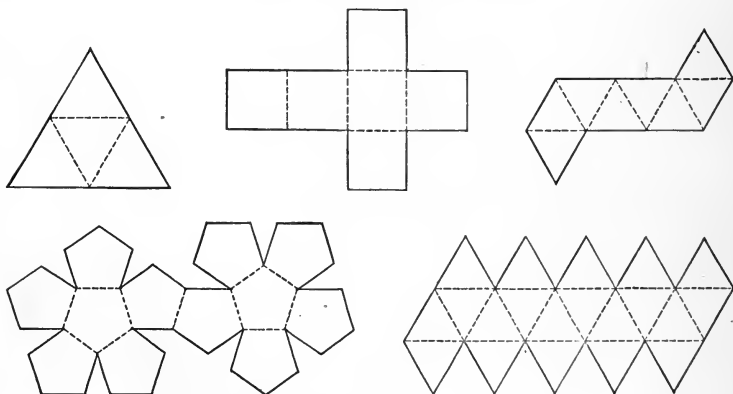

Models of all the regular solids can easily be made by cutting cardboards in the forms of the above diagrams, then cutting half through the cardboard along the dotted lines, folding along the half-cuts, and closing the model by pasting strips of paper along the open edges.

EXERCISES

167. Prove that any two pairs of opposite vertices of a regular octahedron are the vertices of a square.

168. The side of a cube is 6 inches. Find the side of a cube of twice the volume.

NOTE. To Hippocrates of Chios (about 430 B.C.) is due the proof that the solution of the problem of duplicating the cube can be reduced to the finding of two mean proportionals between two given lines, of which one is the side of the given cube and the other is twice that side.

If x and y are two mean proportionals between a and $2a$, we have

$$a : x = x : y = y : 2a.$$

Then $x^2 = ay$ and $y^2 = 2ax$.

Squaring the first, $x^4 = a^2y^2$.

Substituting value of y^2 from the second,

$$x^4 = a^2 \cdot 2ax = 2a^3x.$$

Hence $x^3 = 2a^3$.

That is, the volume of the cube of edge x will be double that of a cube with edge a .

The geometric procedure for the duplication of the cube has been carried out in a variety of ways, usually by finding the intersection of various curves such as parabolas or hyperbolas. Plato (400 B.C.) is said to have solved the problem by means of a mechanical device, but to have rejected the method as not being geometric.

169. One edge of a regular octahedron is 8 inches. Find the volume.

170. A cube and a regular tetrahedron have the same edge. What is the ratio of their volumes?

HINT. See Exercise 126.

171. The base of a regular hexagonal pyramid is 66 square inches, and its altitude is 10 inches. A plane is passed parallel to the base 5 inches from it. Find the ratio of the volume of the original pyramid to that of the one cut off by this plane.

Theorem 33

579. *If two tetrahedrons have a trihedral angle of one congruent to a trihedral angle of the other, their volumes are in the same ratio as the products of the edges of these trihedral angles.*

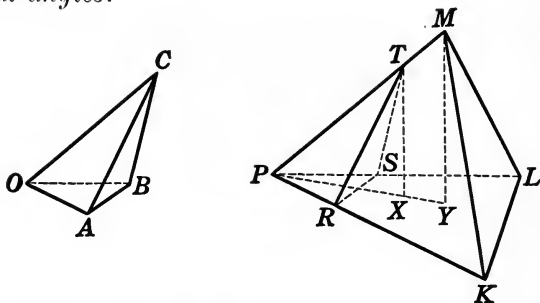

Given $O-ABC$ and $P-KLM$, with trihedrals O and P congruent.

To prove that $\frac{\text{volume } O-ABC}{\text{volume } P-KLM} = \frac{OA \cdot OB \cdot OC}{PK \cdot PL \cdot PM}$.

Proof. Apply the trihedral O to P so that the tetrahedron $O-ABC$ takes the position $P-RST$.

Let TX and MY be the altitudes of the two tetrahedrons.

$$\frac{\text{volume } P-RST}{\text{volume } P-KLM} = \frac{PRS \cdot TX}{PKL \cdot MY} = \frac{PRS}{PKL} \cdot \frac{TX}{MY}. \quad (1) \quad \S 553$$

Now TX is \parallel to MY , § 427

and the plane determined by TX and MY contains PM and hence the $\triangle PTX$ and PMY .

Therefore $\triangle PTX$ is similar to $\triangle PMY$. § 271

Therefore $\frac{TX}{MY} = \frac{PT}{PM}$. (2) Why?

In the $\triangle PRS$ and PKL , we have

$$\frac{PRS}{PKL} = \frac{PR \cdot PS}{PK \cdot PL} = \frac{PR}{PK} \cdot \frac{PS}{PL}. \quad (3) \quad \S 325$$

Hence, substituting (3) and (2) in (1),

$$\frac{\text{volume } P-RST}{\text{volume } P-KLM} = \frac{PR}{PK} \cdot \frac{PS}{PL} \cdot \frac{PT}{PM};$$

or

$$\frac{\text{volume } O-ABC}{\text{volume } P-KLM} = \frac{OA \cdot OB \cdot OC}{PK \cdot PL \cdot PM}.$$

580. Symmetric trihedrals. If two trihedral angles have their parts equal each to each, but arranged in the opposite order, they are called *symmetric*.

For example, the trihedral angles in the two nappes of a triangular pyramidal surface are symmetric. For if one thinks of oneself as

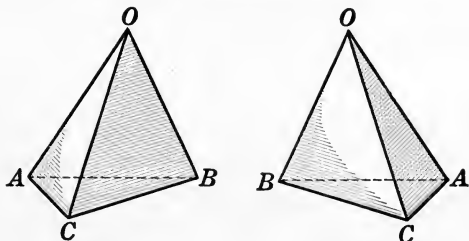

stationed at the vertex and looking first in the direction of the faces of one angle and then in that of the faces of the other, the equal dihedral angles OA, OB, OC in the diagram follow each other in clockwise order on the lower nappe and in counterclockwise order on the upper nappe.

QUERY 1. Can two triangles whose parts are equal but arranged in opposite order be superposed so as to coincide throughout?

QUERY 2. Can two symmetric trihedral angles be superposed so as to coincide throughout?

QUERY 3. Are the dihedral angles of a regular polyhedron all equal?

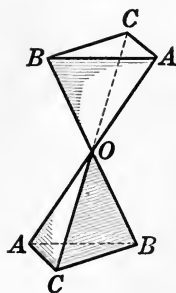

EXERCISE 172. If two trihedral angles have their edges parallel, and all the edges of one trihedral extending in directions from the vertex opposite to the corresponding edges of the other trihedral, the trihedrals are symmetric.

581. Similar polyhedrons. Two polyhedrons are similar if their faces are similar, each to each, and similarly placed, and if their corresponding polyhedral angles are congruent.

It should be observed that similar solids have the same shape but different sizes.

Theorem 34

582. *The ratio of any two corresponding edges of two similar polyhedrons is equal to the ratio of any other corresponding pair.*

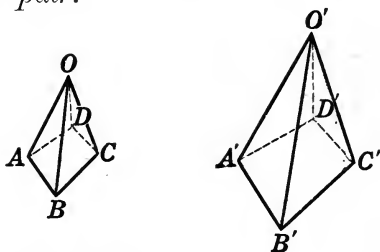

Proof is left to the student.

QUERY 1. Are all regular polyhedrons with the same number of faces similar?

QUERY 2. Are all rectangular solids similar?

EXERCISES

173. The areas of two corresponding faces of two similar polyhedrons are in the same ratio as the squares of any two corresponding edges.

174. Two tetrahedrons are similar if three faces of one are similar and similarly placed to three faces of the other.

175. Two tetrahedrons are similar if a dihedral in one is equal to a dihedral in the other, and if the faces including the dihedral are similar and similarly placed.

176. If a plane is passed parallel to the base of a pyramid, the pyramid cut off is similar to the original one.

Theorem 35

583. *The volumes of two similar tetrahedrons are in the same ratio as the cubes of two corresponding edges.*

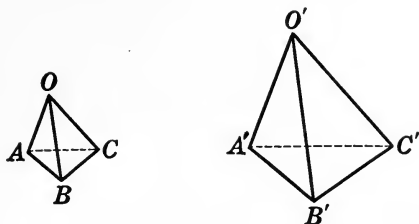

Given two similar tetrahedrons $O-ABC$ and $O'-A'B'C'$, with volumes V and V' respectively.

To prove that
$$\frac{V}{V'} = \frac{\overline{OA}_1^3}{\overline{O'A'_1}^3}.$$

Proof. Trihedral O is congruent to trihedral O' . § 581

Hence
$$\frac{V}{V'} = \frac{OA \cdot OB \cdot OC}{O'A' \cdot O'B' \cdot O'C'} \quad \text{§ 579}$$

$$= \frac{OA}{O'A'} \cdot \frac{OB}{O'B'} \cdot \frac{OC}{O'C'}. \quad (1)$$

The $\triangle OAB$ and $O'A'B'$, OAC and $O'A'C'$, etc. are similar. § 581

Hence
$$\frac{OA}{O'A'} = \frac{OB}{O'B'} = \frac{OC}{O'C'}. \quad (2) \quad \text{Why?}$$

Substituting (2) in (1), we obtain

$$\frac{V}{V'} = \frac{\overline{OA}^3}{\overline{O'A'}^3}.$$

584. Assumption. Any two similar polyhedrons can be divided into the same number of tetrahedrons, similar each to each and similarly placed.

The foregoing statement, a proof of which is rather involved, appears evident if we consider two corresponding points (one in the interior of each polyhedron) and with these points as vertices construct pyramids having as their bases the various faces of the polyhedrons. The pyramids with similar faces for bases are similar, and hence the tetrahedrons into which they may be divided are similar and similarly placed.

Theorem 36

585. *The volumes of two similar polyhedrons are in the same ratio as the cubes of any two corresponding edges.*

Given two similar polyhedrons P and P' , with volumes V and V' and corresponding edges E and E' respectively.

To prove that
$$\frac{V}{V'} = \frac{E^3}{E'^3}.$$

Proof. Divide P and P' into tetrahedrons which are similar each to each and similarly placed. § 584

Let the volumes of the similar tetrahedrons be denoted by $T_1, T'_1; T_2, T'_2; T_3, T'_3$, etc., and let corresponding edges of these tetrahedrons be denoted by $E_1, E'_1; E_2, E'_2; E_3, E'_3$, etc.

Then
$$\frac{T_1}{T'_1} = \frac{E_1^3}{E'^3_1}; \frac{T_2}{T'_2} = \frac{E_2^3}{E'^3_2}, \text{ etc.} \quad \text{§ 583}$$

But
$$\frac{E_1}{E'_1} = \frac{E_2}{E'_2} = \dots = \frac{E}{E'}. \quad \text{§ 582}$$

Therefore
$$\frac{T_1}{T'_1} = \frac{T_2}{T'_2} = \dots = \frac{E^3}{E'^3}. \quad \text{Why?}$$

Hence
$$\frac{T_1 + T_2 + T_3 + \dots}{T'_1 + T'_2 + T'_3 + \dots} = \frac{E^3}{E'^3}, \quad \text{§ 276}$$

or
$$\frac{V}{V'} = \frac{E^3}{E'^3}.$$

586. Similar figures. We can now summarize the whole doctrine of similar figures by the following statements:

Similar plane figures or similar surfaces are in the same ratio as the squares of any two corresponding lines.

Similar solids are in the same ratio as the cubes of any two corresponding lines.

In similar figures of any kind, pairs of corresponding lines are in the same ratio.

EXERCISES

177. If one edge of a polyhedron is 6 inches, what is the length of the corresponding edge of a polyhedron of twice the volume?

178. If the base of one pyramid has nine times the area of the base of a similar pyramid, what is the ratio of their volumes?

179. If a cube has an edge 8 inches long, what is the diagonal of a cube of four times the volume?

180. A regular tetrahedron has a volume of 27 cubic inches. What is the volume of a similar tetrahedron whose edges are each half as long?

181. If the strength of two steel wires varies directly as their cross section, what is the ratio of two weights that can just be supported by wires, one of which is three times as great in diameter as the other?

587. Prismatoids. A *prismatoid* is a polyhedron all of whose vertices lie in two parallel planes.

The lateral faces of prismatoids are either triangles or quadrilaterals. Pyramids, prisms, and frustums of pyramids are special cases of prismatoids.

The terms *base*, *altitude*, etc. are defined for the prismatoid similarly to the corresponding terms as applied to the prism.

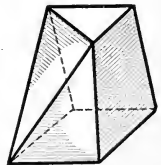

Theorem 37

588. *The volume of a pramatoid equals the product of one sixth the altitude by the sum of the upper base, the lower base, and four times the mid-section.*

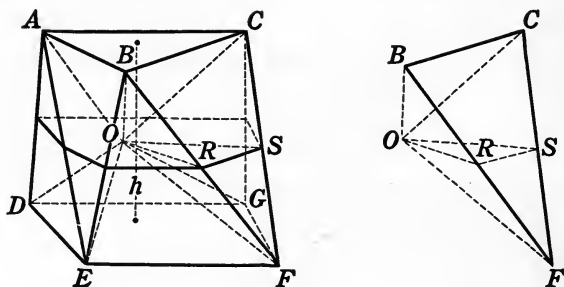

Given the pramatoid $ABCDEFG$ in which the upper base, the lower base, the mid-section, and the altitude are denoted by b , B , M , and h respectively.

To prove that
$$V = \frac{h}{6} (b + B + 4M).$$

Join any point in the mid-section, as O , with the various vertices of the mid-section and of both bases by the lines OB , OR , OF , etc. The planes passed through these lines divide the figure into pyramids with a common vertex at O , like $O-ABC$, $O-DEFG$, which have as their bases b and B respectively, and $O-BCF$, whose base is one of the triangular lateral faces of the pramatoid.

The volumes of these pyramids are found separately.

$$(a) \text{ Volume } O-ABC = \frac{1}{3} \cdot \frac{h}{2} \cdot b = \frac{hb}{6}.$$

$$(b) \text{ Volume } O-DEFG = \frac{1}{3} \cdot \frac{h}{2} \cdot B = \frac{hB}{6}.$$

(c) Volume $O-BCF$ is divided into two parts by the mid-section. Since RS joins the mid-points of the sides of BCF ,

$$\triangle FRS = \frac{1}{4} \triangle FBC, \text{ and volume } O-FRS = \frac{1}{4} O-FBC. \quad \S 553$$

$$\text{But } O-FRS = F-ORS = \frac{1}{3} \left(\frac{1}{2} h \right) ORS = \frac{h}{6} (ORS).$$

$$\text{Therefore volume } O-FBC = 4(O-FRS) = 4 \cdot \frac{h}{6} \cdot ORS = \frac{2}{3} h \cdot ORS.$$

In a similar manner the volume of the other portions of the figure not considered under (a) and (b) can be shown to equal $\frac{2}{3} h$ times the area of the mid-section included in it.

Hence by adding together the portions of the prismatoid not considered in (a) and (b) we obtain as their volume $\frac{2}{3} h \cdot M$.

Adding (a), (b), and this last result,

$$V = \frac{h}{6} (b + B + 4M). \tag{1}$$

NOTE. It can be proved by the integral calculus that the foregoing formula is valid for a much more extensive class of solids than prismatoids. It is usually called the Prismoïdal Formula. Among these solids are included cones, cylinders, and spheres. In fact, the class of solids whose volume can be found by means of (1) is so extensive that the formula finds wide practical application. The formula was first stated by Thomas Simpson (1710-1761), who also gave a list of solids for which it gives accurate results. It may, for example, be assumed that a pile of earth or sand or the excavation for a foundation or a railway cut is so nearly in the form of such a solid that its volume may be computed by the use of (1) without appreciable error.

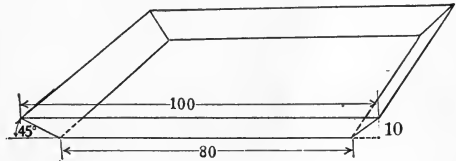

For example, suppose an excavation 100 feet square at the top and 10 feet deep is to be made in sand so that the sides of the excavation form an angle of 45° with the horizontal. The bottom of the excavation is then a square 80 feet on a side, and the area of the section halfway down is a square 90 feet on a side.

$$\begin{aligned} \text{Hence} \quad V &= \frac{10}{6} (80^2 + 100^2 + 4 \times 90^2) \\ &= \frac{10 \times 48,800}{6} = 81,333 \text{ cubic feet.} \end{aligned}$$

EXERCISES

182. Show that the expression for the volume of a pyramid is a special case of (1). In the case of the pyramid, $b = o$, $B = B$, $M = \frac{1}{4}B$. Hence (1) becomes $V = \frac{h}{6}(0 + B + B) = \frac{hB}{3}$.

183. Show that the expression for the volume of the prism is given by the Prismoidal Formula.

184. Show that the volume of a cone, the volume of the frustum of a cone, and the volume of the frustum of a pyramid are each given by the Prismoidal Formula.

185. An irregular pile of earth is 15 feet high and covers 500 square feet. Its mid-section and level top are estimated to contain 400 and 200 square feet respectively. Find the cost of removing it at 50 cents per load, if the truck measures $3 \times 4 \times 9$ feet.

186. A circular pile of sand which stands at rest at an angle of 45° is 6 feet high. How many cubic feet does it contain?

187. An excavation must be carried 20' deep in earth which at rest stands 60° to the horizontal. The bottom must be a square $40' \times 40'$. (1) How large are the top and the mid-section of the excavation? (2) How many cubic feet of earth must be removed?

REVIEW EXERCISES

188. A cubic foot of water weighs about 62 pounds. What must be the side of a square refrigerator pan 6 inches high in order to hold the water from 50 pounds of ice? How many square inches of sheet tin are required to make the pan, allowing half an inch along each seam for folding?

189. A trough is formed by nailing together, edge to edge, two boards 12 feet in length, so that the right section is a right angle. If 15 gallons of water is poured into the trough and it is held level so that a right section of the water is an isosceles right triangle, how deep is the water? (231 cubic inches = 1 gallon.)

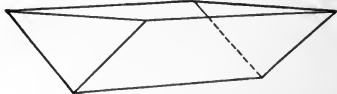

190. Two water tanks in the form of rectangular solids whose tops are on the same level are connected by a pipe through their bottoms. The base of one is 6 inches higher than that of the other. Their dimensions are $4 \times 5 \times 2\frac{1}{2}$ feet and $4 \times 7 \times 3$ feet respectively. How deep is the water in the larger tank when the water they contain equals half their combined capacity?

191. If a right triangle is revolved first about the longer leg and then about the shorter, determine in which case (1) the volume, (2) the lateral area, (3) the total area, is the greater.

HINT. Let the shorter side be a ; the longer side, $a + h$. Then

$$V_1 = \frac{1}{3} \pi a^2 (a + h) = \frac{1}{3} \pi (a^3 + a^2 h).$$

$$V_2 = \frac{1}{3} \pi (a + h)^2 a = \frac{1}{3} \pi (a^3 + 2 a^2 h + ah^2).$$

192. Find (1) the volume and (2) the total area of the solid formed by the rotation of an equilateral triangle about one side.

193. The tensile strength of wire is proportional to the area of its cross section. If a certain wire is just strong enough to support a cube of iron 8 inches on a side, what must be the diameter of the wire which will just support a cube of iron 16 inches on a side?

194. An irregular-shaped body is placed in a cylindrical vessel of water whose radius is r inches. The water rises a inches. What is the volume of the body?

195. The volumes of two cubes are in the ratio of 4 : 5. Find the ratio of (1) their surfaces, (2) their edges.

196. If the total area of one solid is twice that of a similar solid, what is the ratio of (1) their edges, (2) their volumes?

197. The dimensions of a box are $2 \times 3 \times 4$ feet. Find the dimensions of a box of the same shape in order that it may hold three times as much.

198. The bases of two similar pyramids are in the ratio 2 : 3. What is the ratio of (1) their edges, (2) their volume?

199. How long a wire $\frac{1}{16}$ of an inch in diameter can be drawn from a block of copper $2 \times 4 \times 6$ inches?

200. Find the total area of a rectangular solid whose base is 5×9 feet and whose volume is 900 cubic feet.

201. Find the edge of a cube whose total surface is numerically equal to its volume.

202. A sector having an angle of 90° is cut from a circle 8 inches in radius, and the edges of the cut are joined so as to form the lateral area of a cone. Find the volume of this cone.

203. A cone of revolution has a slant height of 10 inches, and its radius is 4 inches. How large an angle must be cut from a circle to form its lateral surface?

204. If the slant height of a cone of revolution is twice the radius, find the angle that must be cut from a circle in order to form its surface.

205. What per cent of a square stick is wasted if the largest possible cylindrical stick is turned out of it on a lathe?

206. What per cent of the volume of a circular cylindrical log of uniform diameter is the volume of the greatest square timber which can be cut from it?

207. The slant height of a cone of revolution makes an angle of 45° with the base. The altitude of the cone is 25 inches. Find the volume.

208. A pipe $\frac{3}{4}$ -inch inside measure conducts water from a spring to a house 300 feet distant. It is desired to empty the pipe after the water has been turned off at the spring. Will a 10-quart pail hold the water?

209. A tank in the form of a rectangular solid $2 \times 3 \times 4$ feet can be filled through a pipe $\frac{3}{4}$ -inch in diameter in 30 minutes. How many feet of water flow through the pipe per second?

210. It is desired to cut off a piece of lead pipe 2 inches in outside diameter and $\frac{1}{4}$ -inch thick, so that it will melt up into a cube of edge 6 inches. How long a piece will it take?

211. The volume of a rectangular solid is 1296 cubic inches, and its dimensions are in the ratio $1 : 2 : 3$. Find the dimensions.

212. If a cone and a cylinder of revolution have the same base and equal altitudes, what is the ratio of their lateral areas?

213. If a child $2\frac{1}{2}$ feet in height weighs 30 pounds, what would be the weight of a man 6 feet tall of the same proportions?

214. Which is the more heavily built, a man $5\frac{1}{2}$ feet tall who weighs 160 pounds, or one 6 feet tall who weighs 200 pounds?

215. A wooden cone of revolution has a diameter of 6 inches and an altitude of 10 inches. An auger hole 1 inch in diameter is bored through it, the axis of the cone and the auger being coincident. (1) What is the volume of the small cone which is cut out from the top of the larger cone? (2) What is the volume of the cylindrical hole?

216. The radius of the lower base of a frustum of a cone of revolution is twice that of the upper base. The slant height is inclined at an angle of 45° to the base. If the altitude of the frustum is 6 feet, find (1) the lateral area, (2) the volume, of the frustum.

217. A circular cone is 4 feet high. The shortest and the longest elements are 6 and 10 feet respectively. Find the volume.

218. How many board feet of lumber is a stick $4'' \times 4''$ at one end, $2'' \times 12''$ at the other end, and 16' long? (One board foot is $1' \times 1' \times 1''$; that is, it contains 144 cubic inches.)

219. If a lead pipe $\frac{1}{4}$ inch thick has an inner diameter of $1\frac{1}{2}$ inches, find the number of cubic inches of lead in a piece of pipe 12 feet long.

220. How many cubic yards of material is needed for the foundation of a barn 40×80 feet if the foundation is 2 feet wide and 12 feet high?

221. A pail 12" high is in the form of a frustum of a cone. If the diameters of the bases are 10" and 12" respectively, find its capacity in quarts.

222. An 80-foot flagpole has upper and lower diameters of 4 and 16 inches respectively. Find the cost of painting it at 5 cents per square foot.

223. A reservoir is in the form of an inverted square pyramid with bases 100 and 90 feet on a side respectively. How long will it require an inlet pipe to fill it if it pours in 400 gallons per minute?

224. Compute the cost of the lumber necessary to resurface a footbridge 16' wide and 150' long with 2" plank if lumber is \$40 per 1000 board feet.

225. A druggist sells a certain kind of powder in a rectangular box $4 \times 2\frac{1}{2} \times 1\frac{1}{4}$ inches for 25 cents, and in a cylindrical can $2\frac{1}{2}$ inches high and $2\frac{1}{2}$ inches in diameter for 20 cents. Which is it more economical to buy?

226. A concrete dam is 4' wide at the top and 12' wide at the lowest point. It is 72' long; it is 8' high at one end and 12' high at the other; at the lowest point, 24' from the latter end, it is 21' high. What would it cost to build it at \$4.60 per cubic yard?

227. A railway embankment across a valley has the following dimensions: width at top, 20 feet; width at base, 45 feet; height, 11 feet; length at top, 1020 yards; length at base, 960 yards. Find its volume.

BOOK VIII

THE SPHERE

GENERAL PROPERTIES OF THE SPHERE

589. Sphere. A *sphere* is a closed surface every point of which is equidistant from a fixed point called the center.

590. Radius. A line connecting any point of the sphere with its center is called a *radius* of the sphere.

Since the sphere is closed, every point in space is either inside, outside, or on, the sphere, according as its distance from the center is less than, greater than, or equal to, the radius.

Terms such as *diameter*, *chord*, and *secant* are used in the same sense for the sphere as they are for the circle.

By *volume* of the sphere we mean the volume of the solid inclosed by the sphere.

591. Another definition of the sphere. A sphere may also be defined as the surface generated by the complete rotation of a semicircle about a diameter.

QUERY 1. If a line is known to have one point inside a sphere, in how many points must it cut the sphere?

QUERY 2. The distances from the center of a sphere to lines which (1) cut, (2) do not cut, the sphere have what relation to the length of the radius?

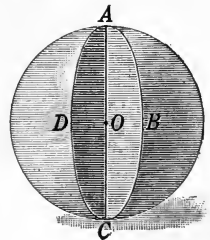
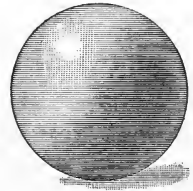

QUERY 3. If two spheres are congruent, is it certain that their centers coincide when the spheres coincide?

QUERY 4. If two spheres are congruent, what can you say of their radii?

QUERY 5. If the radii of two spheres are equal, are the spheres congruent?

QUERY 6. What is the locus of points five inches from a given point?

QUERY 7. What is the locus of points two inches from a sphere which is six inches in diameter?

EXERCISES

1. Prove that any diameter of a sphere is twice as long as the radius.

2. Prove that a diameter is longer than any other chord of a sphere.

Theorem 1

592. *If a plane is perpendicular to a radius of a sphere at its outer extremity, it has no other point in common with the sphere.*

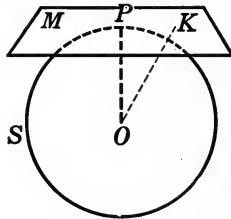

Given the sphere S with center O , and the plane M which is perpendicular to the radius OP at P .

To prove that M meets S only at P .

Proof. Let K be any point in M other than P .

Then $OK > OP$.

§ 422

Therefore K is outside the sphere.

§ 590

Therefore no point of M except P is on S .

593. Tangency. If a sphere and a plane, a sphere and a line, or two spheres have one and only one point in common, they are said to be *tangent* to each other.

The common point is called the *point of contact* in each case.

594. Corollary. *If a plane is tangent to a sphere, it is perpendicular to the radius drawn to the point of contact.*

HINT. Show that the distance from the center of the sphere to the point of contact is shorter than any other line from the center to the plane. Then apply § 422.

QUERY 1. How many planes are tangent to a sphere at a given point?

QUERY 2. What is the locus of the centers of spheres of fixed radius which are tangent to a given plane?

QUERY 3. What is the locus of the centers of spheres which are tangent to both faces of a given dihedral angle?

QUERY 4. What is the locus of the centers of spheres of radius two inches which are tangent to both faces of a dihedral angle?

QUERY 5. What is the locus of the centers of spheres which are tangent to a plane at a given point?

QUERY 6. How many lines are there in each tangent plane to a sphere which have one and only one point in common with the sphere?

QUERY 7. On what kind of surface do all of the tangent lines to a sphere from a fixed exterior point lie? If the point approaches very close to the sphere, what does the surface approach in form? As the point recedes farther and farther from the sphere, what does the surface approach in form?

EXERCISES

3. Prove that a line which is tangent to a sphere is perpendicular to the radius drawn to the point of contact.

4. At a point on a sphere construct a plane tangent to the sphere, giving a reason for each step.

5. If two spheres are tangent to a plane at the same point, prove that their line of centers passes through the point of contact.

Theorem 2

595. *If the distance from the center of a sphere to a plane is less than the radius of the sphere, the plane cuts the sphere in a circle whose center is the foot of the perpendicular drawn from the center of the sphere to the plane.*

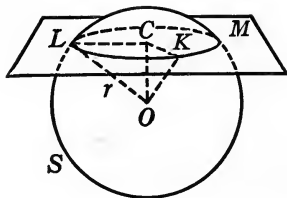

Given any sphere S , with center O and radius r , and a plane M whose distance OC from O is less than r .

To prove that the section in which M cuts S is a circle with center C .

Proof. Connect any two points of the section, as L and K , with C .

Draw OL and OK .

$\triangle OCL$ is congruent to $\triangle OCK$. Why?

Therefore $CK = CL$. Why?

Hence the intersection of S and M is a circle of which C is the center. § 154

596. Great circle. A circle on a sphere whose plane passes through the center of the sphere is called a *great circle*.

597. Corollary I. *All great circles of a sphere are equal and have for their common center the center of the sphere.*

598. Corollary II. *Any two points on a sphere except the extremities of a diameter determine a great circle of the sphere.*

599. Corollary III. *Any three points on a sphere determine a circle of the sphere.*

600. Small circle. A circle on a sphere whose plane does not pass through the center of the sphere is called a *small circle*.

QUERY 1. What can you say of the distance, from the center of a sphere, of a plane (1) which does not cut the sphere, (2) which cuts it, (3) which cuts it in a great circle?

QUERY 2. If a plane through a given tangent line to a sphere swings around this line as an axis, what kind of sections with the sphere are obtained?

QUERY 3. What relation do the circles obtained in Query 2 bear to the given tangent line?

QUERY 4. Is a given tangent line to a sphere tangent to all the great circles and also to all the small circles of the sphere through the point of contact?

QUERY 5. How many equal circles can a set of parallel planes cut from a sphere?

QUERY 6. On what kind of surface are all the radii of a sphere which meet a given small circle?

QUERY 7. What is the intersection of a circular conical surface and a sphere whose center is the vertex of the conical surface?

EXERCISES

5. A great circle divides the surface of a sphere into two congruent parts.

HINT. Prove by superposition.

6. Any two great circles on the same sphere bisect each other.

7. Prove that the distance from the center of a sphere to any one of its tangent lines is the radius of the sphere.

HINT. Pass a plane and apply § 192.

8. Prove that the distances from a fixed point outside a sphere to the points of contact of the lines tangent to the sphere drawn through that point are all equal.

9. Prove the relation $r^2 = s^2 + d^2$,

where r , s , and d denote, respectively, the radius of a sphere, the radius of a small circle, and the distance of the plane of the circle from the center of the sphere. From this relation deduce the following properties of the sphere:

(1) The radius of a small circle is less than that of the sphere.

(2) Circles on a sphere whose planes are equidistant from the center of the sphere are equal.

(3) The converse of (2).

(4) The plane of the larger of two unequal circles of a sphere is nearer the center of the sphere than the plane of the smaller.

(5) The converse of (4).

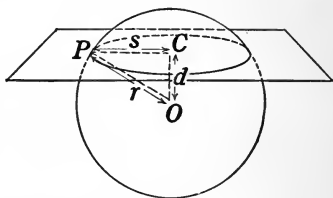

601. Hemisphere. One of the equal parts into which a sphere is divided by a great circle is called a *hemisphere*.

Theorem 3

602. *If two spheres cut each other, their intersection is a circle whose plane is perpendicular to their line of centers.*

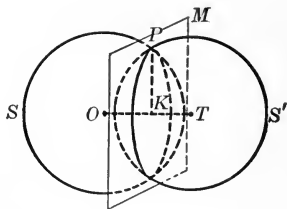

Given two spheres S and S' which cut each other and whose centers are O and T respectively.

To prove that their intersection is a circle whose plane is perpendicular to OT .

Proof. Through any point P of the intersection pass a plane $M \perp$ to the line of centers OT at K . § 417

Then M cuts S in a circle whose center is K and whose radius is KP . § 595

M also cuts S' in a circle whose center is K and whose radius is KP .

These two circles coincide, since they lie in the same plane and have the same center and radius.

Therefore the intersection of S and S' is a circle.

Since M is \perp to OT by construction, the plane of this circle is \perp to the line of centers of S and S' .

EXERCISES

10. The radius of a sphere is 14 inches. What is the radius of a circle whose plane is 4 inches from the center of the sphere?

11. Two spheres whose centers are 24 feet apart have radii 9 and 18 feet respectively. Find the area of the circle of intersection.

12. The diameter of a sphere is 16 inches. Find the distance from the center of this sphere to the plane of a circle whose area is half that of a great circle.

603. **Inscribed sphere.** If a sphere is tangent to each of the faces of a polyhedron, it is said to be *inscribed* in the polyhedron.

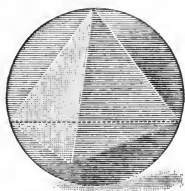
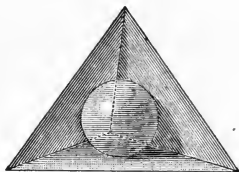

604. **Circumscribed sphere.** If a sphere passes through each of the vertices of a polyhedron, it is said to be *circumscribed* about the polyhedron.

Construction 1

605. Construct a sphere circumscribed about a given tetrahedron.

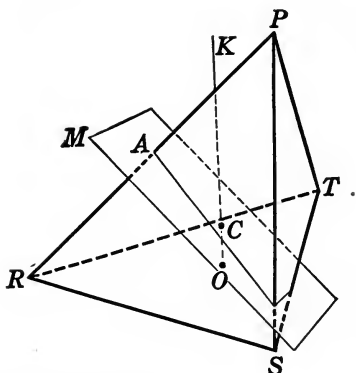

Given any tetrahedron $PRST$.

To construct a sphere which contains the points $P, R, S,$ and T .

Construction. At O , the center of the circle circumscribed about the face RST , construct a line $OK \perp$ to RST . § 420

At A , the middle point of PR , construct a plane $M \perp$ to PR . § 416

Then the point of intersection C of OK and M is the center of a sphere which passes through the points $P, R, S,$ and T .

Proof. It is first necessary to prove that the line OK and the plane M intersect.

If OK were \parallel to M , M would be \perp to the face RST . § 438

Therefore RP would lie in the plane RST § 440

and the figure $PRST$ would not be a tetrahedron.

Hence OK and M must meet in some point C .

Since C lies in OK , it is equidistant from $R, S,$ and T . § 425

Since C lies in M , it is equidistant from P and R . § 423

Therefore C is equidistant from the four points $P, R, S,$ and T , and is the center of a sphere on which they lie.

QUERY 1. How many points are required to determine a sphere on which they all lie?

QUERY 2. If the center is known, how many additional points are necessary to determine a sphere?

QUERY 3. How many spheres contain a given circle?

QUERY 4. What is the locus of the centers of the spheres which contain a given circle?

QUERY 5. How many spheres can be passed through three given points?

QUERY 6. What is the locus of the centers of the spheres which pass through two given points?

QUERY 7. What is the locus of the centers of the spheres with given radius which pass through two points?

QUERY 8. What is the locus of points at a given distance from a given point and equidistant from two given points?

QUERY 9. Two points, A and B , are a distance c apart. What is the locus of points a distance m from A and n from B ? Discuss for all cases.

QUERY 10. Under what circumstances will two circles in different planes determine a sphere?

QUERY 11. What is the locus of points a given distance from a given point and at the same time equidistant from all the points of a given circle? Discuss special cases.

QUERY 12. What is the locus of the centers of the spheres which are tangent to the faces of a given dihedral angle?

EXERCISES

13. Construct a cube circumscribed about a given sphere.

14. Construct a sphere circumscribed about a given cube.

15. Prove that the lines which are perpendicular to the faces of a tetrahedron at the centers of their circumscribed circles meet in a point.

16. Construct a sphere of given radius passing through three given points.

17. Construct a sphere inscribed in a given tetrahedron.

18. The edge of a regular tetrahedron is 8 inches. What is the radius of the circumscribing sphere?

MEASUREMENT OF THE SPHERE

Theorem 4

606. *The area generated by the base of an isosceles triangle rotated about an axis which lies in its plane and contains the vertex, but which does not cut the triangle, equals the product of the projection of the base of the triangle on the axis and the circumference of a circle whose radius is the altitude of the triangle.*

Case I. The base of the triangle does not meet and is not parallel to the axis.

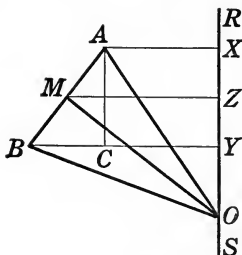

Given any isosceles triangle, OAB , whose base AB does not meet and is not parallel to the line RS , which lies in the plane of OAB and contains the vertex of OAB . Let MO be the altitude of the triangle, and let XY be the projection of AB on RS . And let MZ be the projecting line of M , the midpoint of AB .

To prove that area generated by AB equals $XY \cdot 2\pi MO$.

Proof. AX is \perp to RS , and BY is \perp to RS . § 445

Therefore $XABY$ is a trapezoid Why?

and generates a frustum of a cone when rotated about RS as an axis.

Therefore area generated by $AB = AB \cdot 2\pi MZ$. (1) § 559

Draw $AC \parallel$ to RS .

In $\triangle MOZ$ and BAC , MZ is \perp to RS . § 445

MO is \perp to AB . Why?

OZ is \perp to BC . Why?

Hence the \sphericalangle of $\triangle MOZ$ = respectively the \sphericalangle of $\triangle BAC$ § 76

and $\triangle MOZ$ and BAC are similar. Why?

Hence $AB/MO = AC/MZ$. Why?

That is, $AB \cdot MZ = AC \cdot MO = XY \cdot MO$, Why?

or $AB \cdot 2\pi MZ = XY \cdot 2\pi MO$. § 124

Hence area generated by $AB = XY \cdot 2\pi MO$. § 32

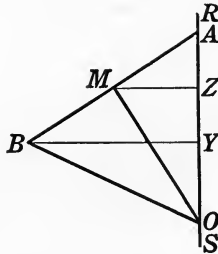

Case II. *The base of the triangle terminates in the axis.*

HINTS. Compare the triangles MOZ and ABY , as in Case I, apply § 556, and prove that

area generated by $AB = AY \cdot 2\pi MO$.

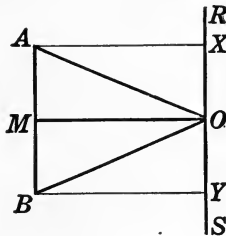

Case III. *The base of the triangle is parallel to the axis.*

HINTS. Apply §§ 502, 500 and prove that

area generated by $AB = XY \cdot 2\pi MO$.

Theorem 5

607. *If an arc of a semicircle is divided into a number of equal parts, and chords are drawn joining the points of division in order, and the figure is rotated about the diameter of the semicircle as an axis, the area generated by the chords equals the product of the sum of their projections on the axis and the circumference of a circle whose radius is their common distance from the center.*

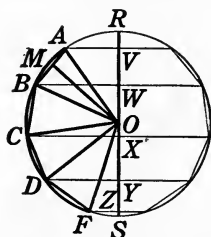

Given the arc AF . Let the points B , C , and D divide it into equal parts; let VW , WX , XY , and YZ be the projections of the equal chords AB , BC , CD , and DF , respectively, on the diameter RS ; and let MO be the common distance of the chords from the center O of the circle.

To prove that the area generated by the broken line $ABCDF$ is equal to $VZ \cdot 2\pi MO$.

Proof. ABO , BCO , CDO , and DFO are equal isosceles Δ . Why?

The projections of their bases on RS are VW , WX , etc. Given

Area generated by AB equals $VW \cdot 2\pi MO$. § 606

Area generated by BC equals $WX \cdot 2\pi MO$.

Area generated by CD equals $XY \cdot 2\pi MO$.

Area generated by DF equals $YZ \cdot 2\pi MO$.

Adding, area generated by broken line $ABCDF$ is equal to

$$(VW + WX + XY + YZ) \cdot 2\pi MO = VZ \cdot 2\pi MO.$$

608. Zone. The portion of a sphere included between two parallel planes which intersect the sphere is called a *zone*.

The distance between the planes is called the *altitude* of the zone.

The two circular sections of the sphere which are made by the parallel planes are called the *bases* of the zone.

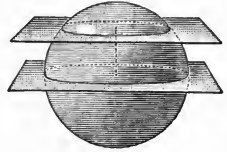

609. Zone of one base. If one of the parallel planes is tangent to the sphere, the zone is said to have *one base*.

If both planes are tangent to the sphere, the zone is the sphere itself, and the altitude of the zone is the diameter of the sphere.

610. Generation of a zone. Since a sphere is generated by the rotation of a circle about a diameter, a zone is generated by the rotation of an arc of a circle about a diameter of the circle.

If the arc meets the axis of rotation, the zone has only one base.

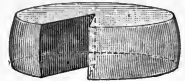

If the arc is a semicircle rotating about its diameter the entire sphere is generated.

611. Area of zone. If in § 607 the number of chords inscribed in the arc is increased without limit while each becomes very short, the figure generated approaches a zone the expression for the area of which may be inferred from the result of Theorem 5. It is observed that as the number of equal chords and arcs increases, the line MO of Theorem 5 increases in length until for very short chords it becomes almost equal to the radius of the sphere. By the theory of limits it is possible to prove the following statement; but since a rigorous proof is too difficult to include here, and since the truth of the proposition is evident after § 607, we shall assume it without further demonstration.

Theorem 6

612. *The area of a zone equals the product of its altitude and the perimeter of a great circle of the sphere.*

613. Corollary I. *If r denotes the radius of a sphere and h the altitude of a zone whose area is Z , then*

$$Z = 2 \pi r h.$$

614. Corollary II. *If r denotes the radius of a sphere and S its area, then*

$$S = 4 \pi r^2.$$

HINT. In § 613, let $h = 2r$.

NOTE. The simplicity of this expression for the area of the sphere is one of the most remarkable results to be found in the whole field of elementary mathematics. That the area of the curved surface of the sphere should turn out to be just 4 (not 4 plus some bothersome irrational number) times the area of the largest section of the sphere suggests a harmonious relationship which would seem even more astonishing if the symmetry of the subject had not led us to take such results as a matter of course.

QUERY 1. If different diameters are used as axes, will a given arc always generate zones with the same altitude?

QUERY 2. In what position do you think that the axis should lie in order that a given arc may generate (1) the zone of least area, (2) the zone of greatest area?

EXERCISES

In the following exercises r and S denote the radius and surface, respectively, of a sphere, and Z denotes the area and h the altitude of a zone.

19. Given $r = 4$. Find S .
20. Given $r = 1/2$. Find S .
21. Given $S = 8\pi$. Find r .
22. Given $r = 6$, $h = 2$. Find Z .
23. Given $r = 9.4$, $h = 5\frac{1}{2}$. Find Z .

24. Given $S = 72\pi$, $h = 2$. Find Z .

25. Given $Z = \pi r$. Find h .

26. On the same sphere or equal spheres the areas of two zones are in the same ratio as their altitudes.

27. The areas of two spheres are in the same ratio as the squares of their radii.

28. The area of a zone of one base equals the area of the circle whose radius is the chord of the generating arc of the zone.

HINT. To prove that $Z = \pi \overline{PA}^2$, pass a section through PA making a great circle, and consider the triangle $PP'A$.

29. A zone of one base is 36π square inches in area, and the chord of its generating arc is 4 inches from the center of the sphere. Find the surface of the sphere.

30. Find the area of the greatest zone which can be generated by an arc whose chord is 9 inches long, on a sphere of radius 16 inches.

31. Prove that half the surface of the earth is included between the parallels 30° N. and 30° S.

32. What portion of a sphere is visible from an exterior point at a distance from it equal to the radius?

33. The radius of a sphere is 5. Find the radius of a sphere having an area three times that of the given sphere.

34. The radius of a given sphere is 8. Find the radius of a sphere having an area one half that of the given sphere.

35. The radius of a given sphere is 10 inches. What is the altitude of a zone whose area is one fourth that of the sphere?

36. The radius of a given sphere is r . What is the radius of a zone of one base whose area is one third that of the sphere?

37. The radius of a given sphere is r . A zone whose area is one fourth that of the sphere has one base twice the radius of the other. How far from the center of the sphere is the larger base?

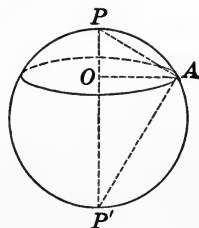

Theorem 7

615. The volume of a sphere equals $\frac{4\pi r^3}{3}$, where r denotes the radius of the sphere.

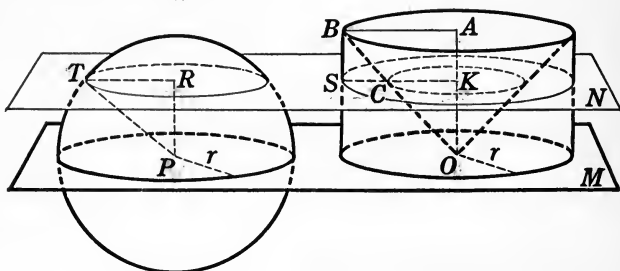

FIG. 1

FIG. 2

Given any sphere of radius r and volume V .

To prove that
$$V = \frac{4\pi r^3}{3}.$$

Proof. Consider the figure consisting of a cylinder of revolution the radius of whose base is r and whose altitude is also r , having had removed from it the cone of revolution whose base is the upper base of the cylinder and whose vertex is at the center of the lower base.

Let the hemisphere of radius r have its base in the same plane with the base of the other figure. Pass a plane through both figures parallel to the common plane of their bases at any distance $PR = OK$ from the base. This plane will cut the sphere in a circle whose radius is RT , and the other figure in a ring whose outer radius is KS and whose inner radius is KC .

In Fig. 1, $RT^2 = PT^2 - PR^2.$ (1) § 284

In Fig. 2, $OA/AB = OK/KC.$ § 263

But $OA = AB.$ Given

Hence, $OK = KC = PR.$

Also $PT = KS = r.$ Given

Substituting KS for PT and KC for PR in (1),

$$RT^2 = KS^2 - KC^2$$

or

$$\pi RT^2 = \pi KS^2 - \pi KC^2.$$

The left-hand member of this equation is the area of the circle cut from the sphere, while the right-hand member is the area of the ring in Fig. 2.

Hence the area of a plane section of Fig. 1 at any distance from the base equals the area of a plane section of Fig. 2 at the same distance from its base.

Therefore the volume of the hemisphere equals the volume of the cylinder with the cone removed. § 481

But the volume of the cylinder minus that of the cone

$$= \pi r^2 \cdot r - 1/3 \pi r^2 \cdot r = 2/3 \pi r^3.$$

Therefore the volume of the hemisphere = $2/3 \pi r^3$,

and the volume of the entire sphere equals $4/3 \pi r^3$. §§ 498, 550

EXERCISES

38. The radius of a sphere is 4 inches. Find (1) the surface, (2) the volume.

39. The surface of a sphere is 616 square inches. Find the volume.

40. A zone whose altitude is 6 inches has an area of 3696 square inches. Find (1) the area, (2) the volume of the sphere.

41. A zone of one base is 36π square inches in area, and the chord of its generating arc is 4 inches from the center of the sphere. Find the volume of the sphere.

42. Prove that the volumes of any two spheres are proportional to the cubes of their radii.

43. If one sphere has twice the surface of another, find the ratio of their volumes.

44. If one sphere has twice the volume of another, find the ratio of their surfaces.

616. Spherical segment. The solid bounded by a zone and the planes of its bases is called a *spherical segment of two bases*.

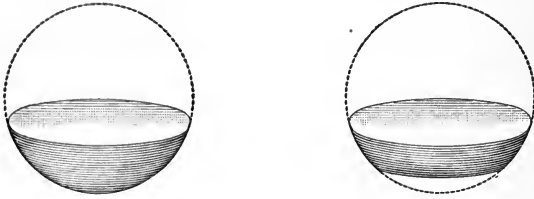

The altitude of a spherical segment is the altitude of its zone.

If the zone has only one base, the segment is said to have one base.

617. Spherical sector. The solid generated by the rotation of a sector of a circle about an axis which passes through the center of the circle, but which does not cut the sector, is called a *spherical sector*.

The bounding surfaces of a spherical sector are a zone, which is called the *base* of the sector, and either one or two conical surfaces, according as the zone has one or two bases.

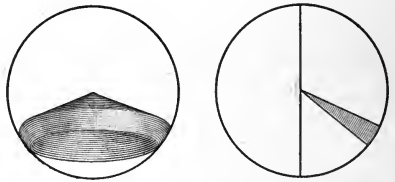

618. Spherical cone. If the base of a spherical sector is a zone of one base, the sector consists of a cone and a spherical segment of one base. This figure is sometimes called a *spherical cone*.

The spherical sector in the adjacent figure may be looked upon either as a spherical segment with two cones removed or as the entire solid sphere with two spherical cones removed.

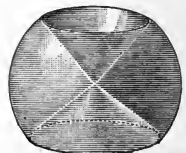

619. Volume of spherical cone. Consider the pyramids whose common vertex is the center of the sphere and whose bases have their vertices on the base of the spherical cone. These pyramids can be taken numerous enough, and their bases can each be taken small enough, so that each altitude is nearly equal to the radius of the sphere, and the sum of their bases is almost exactly equal to the base of the spherical cone. The sum of the pyramids themselves forms a solid approximating the spherical cone as closely as may be desired. Now the volume of each pyramid equals one third the product of its base and altitude, and it can be proved that as the number of pyramids becomes very large and each of their bases becomes very small, the volume of the sum of the pyramids approaches one third the product of the base of the spherical cone and the radius. But since the sum of the pyramids approaches the spherical cone, we may infer the truth of the following theorem, a rigorous proof of which is beyond the scope of this book.

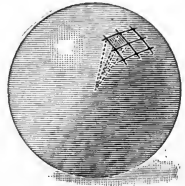

Theorem 8

620. *The volume of a spherical cone equals one third the product of the area of the zone which forms its base, and the radius of the sphere.*

621. Corollary I. *The volume of any spherical sector equals one third the product of the area of the zone which forms its base, and the radius of the sphere.*

622. Corollary II. *If h denotes the altitude of the zone which forms the base of a spherical sector on a sphere of radius r , the volume, V , of the sector is $V = \frac{2\pi r^2 h}{3}$.*

623. Corollary III. *The volume of a spherical segment of one base is*

$$V = \frac{\pi h^2}{3} (3r - h),$$

where h is the altitude of the segment and r is the radius of the sphere.

HINTS. The segment is equal to a spherical cone less the ordinary cone whose base is the base of the segment and whose vertex is at the center of the sphere. Let a denote the radius of the base of the segment.

Then
$$V = \frac{2\pi r^2 h}{3} - \frac{\pi a^2 (r - h)}{3}.$$

But
$$a^2 = h(2r - h). \quad \S 282$$

Hence
$$V = \frac{\pi}{3} [2r^2 h - h(2r - h)(r - h)] = \frac{\pi h^2}{3} (3r - h).$$

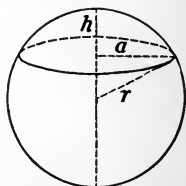

QUERY 1. Explain how the solid bounded by a hemisphere and a plane can be considered as a special case either of a spherical segment or of a spherical sector.

QUERY 2. What is the locus of the centers of spheres of given radius which are tangent to two given intersecting planes?

QUERY 3. What relation must exist between the lengths of the radii and the lengths of the line of centers of two spheres in order that one may lie entirely inside the other?

QUERY 4. What are some examples of great circles on the earth?

QUERY 5. What are some examples of small circles on the earth?

QUERY 6. If a sphere is viewed from a finite distance, can the observer see an entire great circle?

QUERY 7. What kind of figure is the shadow of a sphere cast on a horizontal plane by the sun when it is directly overhead?

EXERCISES

45. Find the volume of the segment on a sphere which is cut off by a plane 2 inches from the center of the sphere whose radius is 6 inches.

46. What is the volume of a segment of one base of a sphere whose radius is r if its altitude is one half that of r ?

47. The water in a hemispherical bowl 18 inches across the top is 6 inches deep. What per cent of the capacity of the bowl is filled?

48. A 4-inch auger hole is bored through a 10-inch sphere, the axis of the hole coinciding with a diameter of the sphere. Find the volume remaining.

REVIEW EXERCISES

49. Prove that two circles which have two points in common, but which do not lie in the same plane, determine a sphere.

50. Prove that a circle and a point not in its plane determine a sphere.

51. Prove that the surface of a sphere and the lateral area of the circumscribed cylinder of revolution are equal.

52. Find the ratio of the volume of a sphere to that of the circumscribed cylinder of revolution.

53. A piece of lead pipe is 50 feet long. Its outer radius is 2 inches, and it is $\frac{1}{8}$ -inch thick. Into how many spherical bullets $\frac{1}{2}$ -inch in diameter can it be melted?

54. A cylinder of revolution is capped on each end by a hemisphere. Show that the total surface of the figure equals the product of its entire length and the circumference of the base of the cylinder.

55. Find the ratio of the volumes of a sphere and a cube if their surfaces are equal.

56. Through a point 6 inches from a sphere of radius 4 inches all the tangent lines to the sphere are drawn. Find the lateral area of the conical surface included between the point and the sphere.

57. The volume and the surface of a sphere are expressed by the same number. Find the radius.

58. Find the volume of a cone whose vertex angle is 60° and which is inscribed in a sphere whose radius is 10 inches.

59. The outside diameter of a spherical iron shell 2 inches thick is 14 inches. Find its weight if a cubic inch of iron weighs 4.2 ounces.

60. A wooden sphere whose radius is 15 inches rests in a circular hole in a board the radius of which is 5 inches. How far below the upper surface of the board does the sphere extend?

61. Find the volume of a cube inscribed in a sphere of radius r .

62. Find the volume of a regular octahedron inscribed in a sphere of radius r .

63. Prove that two lines tangent to a sphere at the same point determine the tangent plane to the sphere at that point.

64. Referring to the Prismoidal Formula in § 588, prove that the volume of a sphere is given by that Formula.

HINT. The areas of the two extreme sections are each zero, while the mid-section is a great circle.

65. Prove that the volume of a spherical segment of one base can be found by the Prismoidal Formula.

66. A cylindrical glass of radius 1.5 inches and altitude 6 inches is filled with water to a depth of 2 inches. If three spheres each 1 inch in diameter are dropped into the glass, by how much is the level of the water raised?

GEOMETRY ON THE SPHERE

624. **Practical importance of spherical geometry.** We shall now study briefly the properties of figures drawn on a sphere. The fact that in the sciences of Geodesy, Astronomy, Navigation, and to a certain extent Civil Engineering, the theorems of Spherical Geometry find important application gives practical significance to this part of our subject.

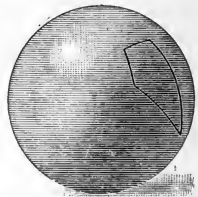

625. **Spherical polygon.** The portion of a sphere bounded by arcs of great circles is called a *spherical polygon*.

626. Spherical angle. The figure formed on a sphere at the point where two arcs of great circles meet each other is called a *spherical angle*.

627. Measure of a spherical angle. The *numerical measure of a spherical angle* is equal to the numerical measure of the angle between the tangents to the great circles at their point of intersection.

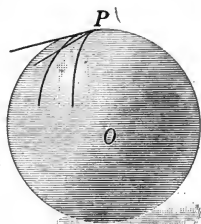

In this text it is not necessary to define or to discuss the angle between two small circles or other curves which may be drawn on the sphere.

Terms which are used in spherical geometry in the same sense as in plane geometry will not be defined again.

QUERY. Does it make any difference which point of intersection of two great circles is taken in defining the measure of the angle between them?

EXERCISES

67. Prove that the angle between two great circles is equal to the angle between their planes.

68. Construct the arc of a great circle making an angle of (a) 30° , (b) 90° , (c) 45° with a given great circle at a given point.

628. Relation between spherical polygons and polyhedral angles. If radii of the sphere are drawn from the vertices of a spherical polygon, and the planes determined by successive pairs of these radii are passed, a polyhedral angle is formed which is intimately related to the polygon.

Prove each of the following propositions relating to the spherical polygon:

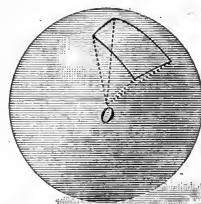

629. *The face angles of a polyhedral angle are measured by the arcs which form the sides of the corresponding spherical polygon.*

630. *The dihedral angles of a polyhedral angle are equal to the angles of the corresponding spherical polygon.*

HINT. Apply §§ 627 and 432.

631. *The sum of the sides of a convex spherical polygon is less than a great circle.*

HINT. Apply §§ 629, 572.

632. *Any side of a spherical triangle is less than the sum of the other two sides.*

HINT. Apply § 570.

633. Congruence. Two spherical triangles are *congruent* if their sides and their angles are equal each to each and arranged in the same order.

As in the case of all other geometric figures, if two spherical triangles are identical in every respect, they may be looked upon as merely different positions of the same figure and may, by § 20, be superposed.

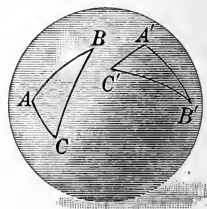

634. Symmetric spherical triangles. Two spherical triangles are *symmetric* if their parts are equal each to each but arranged in opposite orders when both triangles are viewed from the center of the sphere.

From an inspection of the figure it appears that the triangles determined by vertical trihedral angles (§ 580) whose vertex is at the center of the sphere are symmetric, since their angles and their sides are equal each to each (§§ 629, 630) and the corresponding parts are arranged in opposite orders when viewed from the center of the sphere.

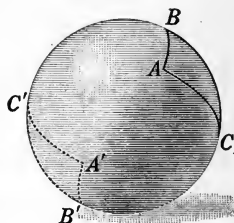

Theorem 9

635. *Two spherical triangles on the same sphere or on equal spheres, which have the three sides of one equal respectively to the three sides of the other, are either congruent or symmetric, according as the equal sides are arranged in the same or in opposite orders.*

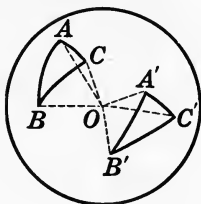

Case I. *When the equal sides are arranged in the same order.*

Given the two spherical triangles ABC and $A'B'C'$, in which the corresponding sides are equal and are arranged in the same order.

To prove that $\triangle ABC$ is congruent to $\triangle A'B'C'$.

Proof. Construct the trihedral \sphericalangle corresponding to ABC and $A'B'C'$.

Then the face \sphericalangle of $O-ABC$ are equal to the face \sphericalangle of $O-A'B'C'$ and are arranged in the same order. § 629

Hence the dihedral $\sphericalangle OA = OA'$, $OB = OB'$, $OC = OC'$, § 569
and $\angle ABC = \angle A'B'C'$, $\angle ACB = \angle A'C'B'$, $\angle BAC = \angle B'A'C'$. § 630

Therefore $\triangle ABC$ is congruent to $\triangle A'B'C'$. § 633

Case II. *When the equal sides are arranged in opposite order.*

Given the two spherical triangles ABC and $A'B'C'$, whose corresponding sides are equal and arranged in opposite order.

To prove that $\triangle ABC$ is symmetric to $\triangle A'B'C'$.

Proof. The demonstration is identical, except that the trihedral angles, and therefore the triangles, are symmetric. § 634

Theorem 10

636. *The angles opposite the equal sides of an isosceles spherical triangle are equal.*

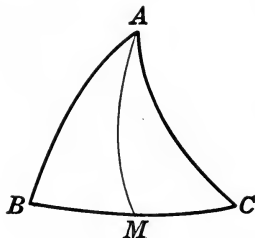

Given the spherical triangle ABC having the side AB equal to AC .

To prove that $\angle B = \angle C$.

Proof. Construct the mid-point of the arc BC and denote it by M .

Let AM be the arc of the great circle determined by A and M . § 598

Then the spherical $\triangle AMB$ and AMC are symmetric. § 634

Therefore $\angle B = \angle C$. § 635

QUERY 1. Are isosceles spherical triangles whose parts are equal each to each necessarily congruent?

QUERY 2. Are isosceles spherical triangles whose parts are equal each to each necessarily symmetric?

QUERY 3. If you try to superpose two symmetric spherical triangles by turning one of them over so that the equal parts are arranged in the same order, why are you unable to do it? Is the same difficulty met in the case of plane triangles?

QUERY 4. If two triangles are symmetric to the same triangle, are they necessarily congruent?

QUERY 5. If from any point of AM in the figure above two arcs of great circles are drawn to B and C respectively, are these arcs necessarily equal?

QUERY 6. Can A in the figure above be so situated that the angles B and C are both right angles?

637. Poles. The *poles of a circle* on a sphere are the points where a line perpendicular to the plane of the circle at its center intersects the sphere.

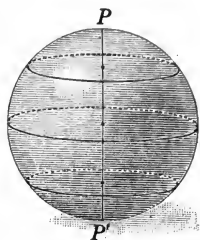

QUERY 1. How many poles does a circle on a sphere have?

QUERY 2. How can one obtain a set of circles on a sphere which have the same poles?

QUERY 3. Can two great circles have the same poles?

EXERCISES

69. Prove that every circle of a sphere through the poles of a given circle is a great circle.

70. Every point on a circle of a sphere is equidistant from a pole of that circle.

Theorem 11

638. *The arcs of the great circles joining any point of a small circle to one of its poles are equal.*

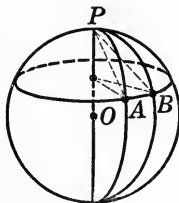

HINT. Apply §§ 25, 179.

QUERY 4. What kind of a spherical triangle is PAB ?

639. *Corollary.* *The points on a sphere which are a constant distance from a fixed point on the sphere lie on a circle of the sphere of which the fixed point is the pole.*

HINTS. Let P be the fixed point and PA be the constant distance. Pass the plane through A which is perpendicular to the radius PO , and apply §§ 425 (1), 595.

640. Constructions on the sphere. It follows from § 639 that if the point of a pair of compasses is placed on a point of a sphere and a continuous curve is drawn on the sphere with the aid of the compasses, this curve will be a circle of the sphere. If it is intended to perform the constructions of spherical geometry by operations that can be carried out on the surface of the sphere, this method of drawing circles must replace their determination by the passing of planes.

A method of drawing a great circle determined by two given points is found in § 654.

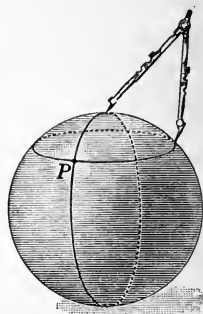

Construction 2

641. Construct the diameter of a sphere from measurements on its surface.

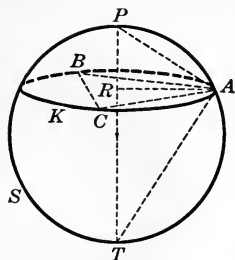

FIG. 1

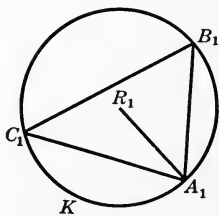

FIG. 2

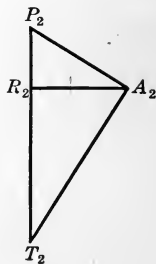

FIG. 3

Given a sphere S .

To construct its diameter from measurements on its surface.

Analysis. If K is a small circle on S and its poles are P and T , one observes that the triangle PAT is a right triangle, and that AR is the altitude on the hypotenuse PT . If we can construct AP and AR , the triangle APR and hence APT can be constructed. The diameter PT will then be found.

Construction. Set the compasses with the distance AP between the points and construct K , a small circle of the sphere (Fig. 1). § 639

With the compasses determine the lengths of the chords AB , BC , and CA , which join any three points of K , as A , B , and C .

In a plane construct the triangle $A_1B_1C_1$, whose sides are equal respectively to AB , BC , and CA (Fig. 2). § 232

Circumscribe the circle K about $A_1B_1C_1$ and denote its center by R_1 .

Construct a plane right triangle $P_2A_2T_2$ (Fig. 3) having one leg, A_2P_2 , equal to AP , and the altitude on the hypotenuse, A_2R_2 , equal to A_1R_1 .

P_2T_2 is the required diameter.

Proof. PT is \perp to plane of circle K . § 637

Therefore AR is the altitude on PT . § 414

Also PAT is a rt. \angle . § 217

Now $\triangle A_1B_1C_1$ is congruent to $\triangle ABC$. § 33

Therefore $A_1R_1 = AR$. § 27

But $A_2R_2 = A_1R_1$,

and $P_2A_2 = PA$. Why?

Therefore $\triangle P_2A_2R_2$ is congruent to $\triangle PAR$, § 97

and $\triangle P_2A_2T_2$ is congruent to $\triangle PAT$. Why?

Hence P_2T_2 is equal to PT , the diameter of S .

642. Polar distance. The length of the arc of a great circle joining any point of a great or a small circle of a sphere to the nearer pole of the circle is called the *polar distance* of the circle.

Thus, in the figure the arc AP is the polar distance of the circle.

643. Corollary. Two equal circles on a sphere have equal polar distances.

HINT. Prove by superposition.

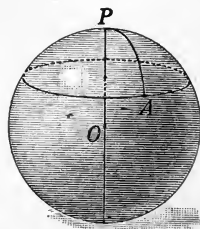

Theorem 12

644. *Two symmetric spherical triangles are equal in area.*

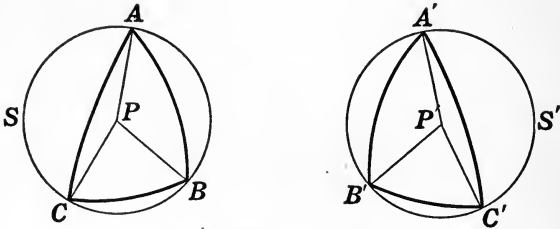

Given the two symmetric spherical triangles ABC and $A'B'C'$, that is, two spherical triangles whose parts are equal each to each but arranged in opposite orders.

To prove $\triangle ABC = \triangle A'B'C'$.

Proof. Pass the planes determined by the vertices of ABC and $A'B'C'$, respectively, forming small circles S and S' , in which the given spherical \triangle are inscribed.

Since $AB = A'B'$, $AC = A'C'$, $BC = B'C'$, Hyp.

the sides of the plane $\triangle ABC$ and $A'B'C'$ are equal. § 178

Hence the two small circles are equal. Why?

Let P and P' be the poles of S and S' respectively.

Then the spherical $\triangle PAB$, PAC , PCB , $P'A'B'$, $P'A'C'$, $P'C'B'$, are all isosceles. § 638

Therefore

$$\triangle PAC = \triangle P'A'C', \triangle PAB = \triangle P'A'B', \triangle PCB = \triangle P'B'C'. \quad \S 635$$

Adding,

$$\triangle PAC + \triangle PAB + \triangle PCB = \triangle P'A'C' + \triangle P'A'B' + \triangle P'B'C',$$

or

$$\triangle ABC = \triangle A'B'C'.$$

645. Relation between plane and spherical geometry. The subject of plane geometry consists in proving propositions which follow from the assumptions and definitions there laid down. We have also a spherical geometry, in which the figures are drawn not on a plane but on a sphere. In order to understand the similarities and the contrasts between plane geometry and spherical geometry, it is necessary to determine what figures on the sphere correspond to the line and to the circle on the plane, and to find out how closely the assumptions made regarding the properties and relations of these fundamental elements in the plane may be carried over to spherical geometry.

We have already seen (§ 640) that a small circle on a sphere can be drawn with compasses and therefore corresponds to a circle in the plane. In fact, a small circle is the curve on the sphere such that the distances to any of its points from the pole of the circle are equal.

The two most important properties of the line in plane geometry are the following:

1. A line is determined by any two of its points.
2. The shortest path between two points of a plane is along the line joining them.

From § 598 it follows that a great circle is determined by any two of its points unless those points lie at the extremities of a diameter. With the exception noted the great circle has property 1 of the line in a plane.

The same exception appears when we make the statement regarding great circles corresponding to the fact that two lines in a plane never have two points in common, for two great circles never have two points in common except those points which are the extremities of a diameter.

We shall now show that (2) corresponds to a property of the great circle.

Theorem 13

646. *The minor arc of the great circle joining two points on a sphere is the shortest curve on the sphere connecting the two points.*

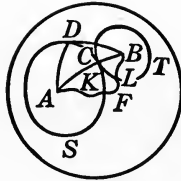

Given two points, A and B , on the sphere, and AB the minor arc of the great circle joining them.

To prove that AB is the shortest curve on the sphere connecting A and B .

Proof. Select any point C on the arc AB . With A as a center and with AC as radius construct the small circle S . Similarly, with B as a center and BC as radius construct T . § 639

The circles S and T have only the point C in common.

For, take D , any point on S other than C .

In the spherical $\triangle ABD$, $AD + DB > AC + CB$. § 632

But $AD = AC$. § 638

Therefore $DB > CB$. Why?

Hence D is not on T , and consequently is not common to S and T .

Now let AFB be any curve on the sphere connecting A and B which does not contain C .

It must cut S and T in distinct points K and L , by the first part of the proof.

Consider the curve which might be drawn connecting A and C , which is congruent to AK ; and the curve similarly connecting B and C , which is congruent to LB .

The sum of the lengths of these curves is less than $AKLB$ by the length of KL .

Hence there is a curve on the sphere through C joining A and B , which is shorter than AFB .

But since C was any point on the minor arc AB , the shortest curve on the sphere connecting A and B must contain all points of AB , and hence coincide with it.

647. Distances on a sphere. We are now justified in calling the minor arc of the great circle joining two points on the sphere the *shortest distance* between them, and in taking the great circle as the figure in spherical geometry which corresponds to the straight line in plane geometry.

QUERY 1. How many points are required to determine a circle in the plane? Mention any exception.

QUERY 2. How many points are required to determine a small circle on the sphere? Mention any exception.

QUERY 3. What use is made in navigation of the fact stated in § 646?

648. Assumption of free motion on a sphere. Since the sphere has the same curvature throughout, it follows that figures on the sphere may be moved from place to place upon it without altering their size or shape. This corresponds to the important assumption of plane geometry contained in § 20.

649. Restrictions on spherical geometry. In two important respects geometry on the sphere differs from geometry in the plane.

In the plane, triangles whose parts are equal each to each but arranged in opposite order, like those in the adjacent figure, can be brought into coincidence by turning one of them over in space and applying the equal parts to each other.

Symmetric triangles on the sphere cannot be brought into coincidence in this way, as one can easily see by cutting out the symmetric triangles from the peel

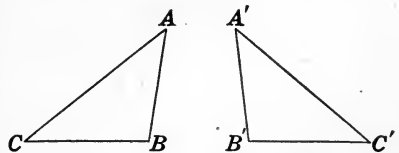

of an orange. Although symmetric spherical triangles are not congruent, they are equal in area (§ 644).

Since every pair of great circles on a sphere meet, there is nothing on the sphere corresponding to parallel lines in the plane. For parallel lines never meet however far they are produced. Hence theorems in plane geometry which depend either on the existence of parallel lines or on the parallel assumption (§ 45) cannot be carried over into spherical geometry. If, however, we are careful to avoid such theorems, we may state a large number of theorems from plane geometry which are true on the sphere.

The following theorems of spherical geometry may be stated without proof, since the corresponding theorems in plane geometry do not depend on the notion of parallels.

1. At a point in a great circle, one and only one great circle can be drawn perpendicular to it.

2. Vertical angles are equal.

3. Two right spherical triangles are congruent if the hypotenuse and an adjacent angle of one are equal respectively to the hypotenuse and an adjacent angle of the other, and if the corresponding parts are arranged in the same order.

4. Two spherical triangles on the same sphere are congruent if two sides and the included angle are equal respectively to two sides and the included angle of the other and if the corresponding parts are arranged in the same order in the two triangles.

5. Two spherical triangles on the same sphere are congruent if a side and the adjacent angles of one are equal to an angle and two adjacent sides of the other, and if the corresponding parts are arranged in the same order.

It should be noted that 4 and 5 may be proved by superposition in precisely the same manner as the corresponding theorems in plane geometry.

EXERCISES

71. Two spherical triangles on the same sphere are symmetric if two sides and the included angle in one are equal to two sides and the included angle in the other, and if the corresponding parts are arranged in opposite orders.

HINTS. Denote the given triangles by T_1 and T_2 . The triangle symmetric to T_1 has its parts arranged in the same order as the corresponding parts of T_2 , and by 4 above is congruent to T_2 . Hence T_1 and T_2 are symmetric.

72. Two spherical triangles on the same sphere are symmetric if a side and two adjacent angles of one are equal to a side and two adjacent angles of the other, and if the corresponding parts are arranged in opposite orders.

73. Find four theorems other than those given on page 476 which correspond to theorems in plane geometry and whose truth can be inferred without proof.

74. Find four theorems of plane geometry which correspond to propositions in spherical geometry which are not true.

650. Sum of angles in a spherical triangle. Since parallels do not exist on the sphere, there is no such figure as a spherical parallelogram, trapezoid, or square. The theorem of plane geometry that the sum of the angles in a triangle equals two right angles necessarily depends upon the parallel assumption. Since this assumption does not hold upon the sphere, one would not expect the sum of the three angles of a spherical triangle to equal 180 degrees. We now proceed to prove the theorems which will lead us to the facts in the case of spherical triangles.

651. Quadrant. The arc of a great circle subtended by a right angle at the center of a sphere is called a *quadrant*.

652. Corollary. *The polar distance of a great circle is a quadrant.*

Theorem 14

653. *If two points are taken a quadrant's distance from a given point, they determine the great circle of which the given point is the pole.*

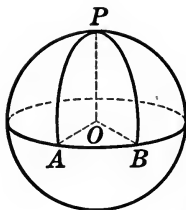

Given the point P on a sphere, and two other points of the sphere, A and B , such that PA and PB are both quadrants.

To prove that the great circle of which AB is an arc has P for its pole.

Proof. Pass the planes of the great circles determined by PA , PB , and AB respectively.

These planes intersect at O , the center of the sphere. § 596

$$\angle POA = \angle POB = 90^\circ. \quad \text{Why?}$$

Therefore PO is \perp to the plane of AB , § 415

and P is the pole of the great circle of which AB is an arc. § 637

654. Corollary. *Construct on the sphere a great circle determined by two given points.*

HINTS. Let the given points be A and B . Construct the point of intersection of the great circles of which A and B are poles (§ 640), and apply § 653.

EXERCISE 75. If two great circles on the same sphere are both perpendicular to a given great circle on that sphere, they meet at the poles of the given great circle.

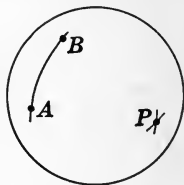

Theorem 15

655. *A spherical angle is measured by the arc of the great circle of which its vertex is a pole, and which is included between its sides, produced if necessary.*

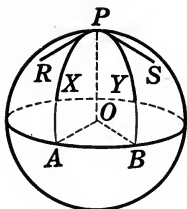

Given any spherical angle XPY , and A and B the points where the sides of this angle, produced if necessary, meet the great circle of which P is the pole.

To prove that $\angle XPY$ *is measured by arc* AB .

Proof. Draw the tangents RP and SP to the great circles AP and BP respectively.

Then $\angle XPY$ is measured by $\angle RPS$. § 626

But RP and SP are both \perp to PO . § 192

Also AO and BO are both \perp to PO . Why?

Therefore $\angle AOB = \angle RPS$. Why?

But $\angle AOB$ is measured by the arc AB . Why?

Therefore $\angle RPS$ or $\angle XPY$ is measured by the arc AB .

656. Corollary. *If one great circle passes through a pole of another, the circles are perpendicular to each other.*

QUERY. If the angle XPY in the figure for Theorem 15 is 40° , how many degrees are there in the sum of the angles of the triangle PAB ?

EXERCISE 76. If one vertex of a spherical triangle is the pole of the opposite side, prove that the sum of the angles of the triangle equals the sum of its sides, each measured in degrees.

NOTE. Since the measure of both the dihedral angle and the spherical angle are defined in terms of certain plane angles, it follows that they are both expressed numerically in terms of the units which measure plane angles, namely, degrees, minutes, and seconds. The arc of a circle is also measured in terms of these units. But this fact does not imply that these magnitudes are of the same kind, any more than the measure of the height of houses, trees, and mountains in terms of feet implies any similarity in their geometric form.

QUERY 1. What is the locus of points a quadrant's distance from a given point on a sphere?

QUERY 2. Is each angle of any spherical triangle measured by the side opposite it?

QUERY 3. Can a spherical triangle be constructed so that each angle has the same measure as its opposite side?

QUERY 4. Can a spherical triangle be constructed so that two, but not three, angles are measured by the sides opposite them?

657. Polar triangle. Let ABC be a spherical triangle. Let A' be the pole of the great circle of which BC is an arc, which is no more than a quadrant's distance from A . Let B' and C' be similarly chosen with respect to the other sides of ABC . Then $A'B'C'$ is called the *polar triangle* of ABC .

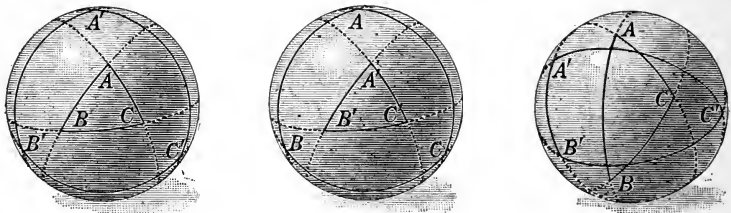

An inspection of the above figures will show that $A'B'C'$ will lie entirely outside, or entirely inside, ABC , according as the sides of ABC are all less than a quadrant or all greater than a quadrant. If at least one side of ABC is less than a quadrant, while at least one side is greater than a quadrant, its polar triangle will overlap it.

Theorem 16

658. *If $A'B'C'$ is the polar triangle of ABC , then ABC is the polar triangle of $A'B'C'$.*

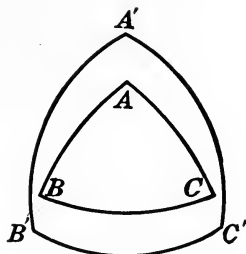

Given any triangle ABC and its polar triangle $A'B'C'$.

To prove that ABC is also the polar Δ of $A'B'C'$.

Proof. C' is the pole of AB , and B' is the pole of AC . § 657

Hence A is a quadrant's distance from B' and from C' . § 652

Hence A is the pole of $B'C'$. § 653

Since A is in the same hemisphere with A' , by hypothesis, it is one vertex of the polar Δ of $A'B'C'$. § 657

Similarly, B and C are vertices of the polar Δ of $A'B'C'$.

Therefore ABC is the polar Δ of $A'B'C'$.

QUERY 1. Is there any triangle on the sphere which is its own polar triangle?

QUERY 2. If two sides of a triangle are quadrants, does it bear any particular relation to its polar triangle?

QUERY 3. If one side of a spherical triangle is a quadrant, does it bear any particular relation to its polar triangle?

QUERY 4. If two angles of a spherical triangle are right angles, does the triangle bear any particular relation to its polar triangle?

EXERCISE 77. Construct the polar triangle of a given triangle, giving a reason for each step.

Theorem 17

659. *Each angle of a spherical triangle is the supplement of the side lying opposite it in its polar triangle.*

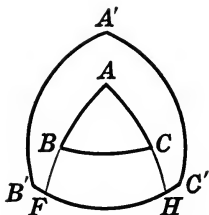

Given any spherical triangle ABC and its polar triangle $A'B'C'$.

To prove that

$$\angle A + B'C' = 180^\circ, \quad \angle B + A'C' = 180^\circ, \quad \angle C + B'A' = 180^\circ.$$

Proof. Let F and H be the intersections of $B'C'$ with AB and AC produced, respectively.

$$\text{Now} \quad C'F = 90^\circ \text{ and } HB' = 90^\circ. \quad \S 657$$

$$C'F + HB' = C'H + HF + HF + FB' = 180^\circ. \quad \text{Why?}$$

$$\text{But} \quad HF \text{ measures } \angle A. \quad \S 655$$

$$\text{Hence } (C'H + HF + FB') + HF = C'B' + \angle A = 180^\circ. \quad \text{Why?}$$

$$\text{Similarly, } \angle B + A'C' = 180^\circ \text{ and } \angle C + A'B' = 180^\circ.$$

QUERY 1. If a spherical triangle is equilateral, what can be said of its polar?

QUERY 2. If a spherical triangle is equiangular, what can be said of its polar?

QUERY 3. If a spherical triangle is isosceles, what can be said of its polar?

QUERY 4. If a spherical triangle has two angles equal to each other, what can be said of its polar?

QUERY 5. If all of the angles of a spherical triangle are right angles, what can be said of its polar?

Theorem 18

660. *Two spherical triangles on the same sphere which have three angles of one equal to three angles of the other are congruent or symmetric, according as the corresponding parts are arranged in the same or in opposite orders.*

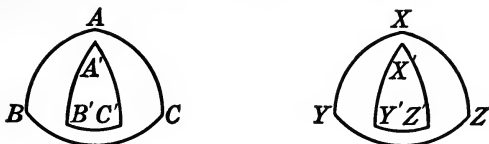

Case I. *When the parts are arranged in the same order.*

Given the spherical triangles ABC and XYZ , in which angle A equals angle X , angle B equals angle Y , angle C equals angle Z , and the parts A , B , and C follow each other in the same order as the parts X , Y , and Z .

To prove that $\triangle ABC = \triangle XYZ$.

Proof. Construct the polar triangles $A'B'C'$ and $X'Y'Z'$.

$$A'B' = 180^\circ - C, \quad X'Y' = 180^\circ - Z, \text{ etc.} \quad \S 659$$

Therefore $A'B' = X'Y'$, $B'C' = Y'Z'$, and $C'A' = Z'X'$. Why?

Hence $\triangle A'B'C'$ is congruent to $\triangle X'Y'Z'$, $\S 635$

and $\angle A' = \angle X'$, $\angle B' = \angle Y'$, and $\angle C' = \angle Z'$. $\S 27$

Hence $BC = YZ$, $CA = ZX$, and $AB = XY$. $\S 659$

Therefore $\triangle ABC = \triangle XYZ$. $\S 635$

Case II. *When the parts are arranged in opposite orders.*

Denote the given triangles by T_1 and T_2 .

Any triangle, such as S , which is symmetric to T_1 has its angles equal to those of T_2 and the corresponding parts arranged in the same order as those in T_2 .

Hence the triangle S is congruent to T_2 . Case I.

Therefore, since T_1 and S are symmetric, it follows that T_1 and T_2 are symmetric.

NOTE. It is observed that this theorem is in striking contrast to the corresponding theorem in plane geometry. Since congruence (or symmetry) follows from equality of angles in two spherical triangles, there is no such thing as similar triangles in spherical geometry. Hence it is possible to construct only one triangle on a sphere whose angles are known.

EXERCISES

78. If two angles of a spherical triangle are equal, the triangle is isosceles.

79. If the three angles of a spherical triangle are equal, the triangle is equilateral.

80. If two trihedral angles have the dihedrals of one equal to the dihedrals of the other, the corresponding face angles are equal and the trihedrals are either symmetric or congruent.

Theorem 19

661. *The sum of the angles of a spherical triangle is greater than 180° and less than 540° .*

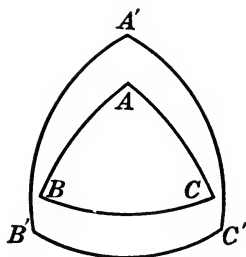

Given the spherical triangle ABC .

To prove that $180^\circ < \angle A + \angle B + \angle C < 540^\circ$.

Proof. Construct the polar $\triangle A'B'C'$.

Then

$$\angle A = 180^\circ - \angle B'C'$$

$$\angle B = 180^\circ - \angle A'C'$$

$$\angle C = 180^\circ - \angle A'B'$$

§ 659

Adding, $\angle A + \angle B + \angle C = 540^\circ - (A'B' + A'C' + B'C')$.

Since $A'B' + A'C' + B'C'$ cannot be zero (or negative),

$$\angle A + \angle B + \angle C < 540^\circ.$$

But $A'B' + A'C' + B'C' < 360^\circ$. § 631

Hence $180^\circ < \angle A + \angle B + \angle C < 540^\circ$. Why?

QUERY 1. Describe the appearance of a spherical triangle the sum of whose angles is 181° .

QUERY 2. Describe the appearance of a spherical triangle the sum of whose angles is nearly 540° .

QUERY 3. Could an equiangular triangle each of whose angles is 60° exist on a sphere?

EXERCISE 81. The sum of the angles of a spherical polygon of n sides is greater than $2(n - 2)$ right angles.

662. Birectangular triangle. A spherical triangle two of whose angles are right angles is called a *birectangular triangle*.

The arc between the two right angles is called the *base*, the opposite vertex is called the *vertex*, of the triangle.

QUERY 1. Why does the vertex angle of a birectangular triangle contain the same number of degrees as the base?

QUERY 2. Why is the vertex of a birectangular triangle the pole of the base?

663. Lune. A *lune* is the portion of a sphere included between two great semi-circles which meet each other.

The entire sphere may be considered a lune whose angle is 360° .

664. Spherical degree. The birectangular triangle whose third angle is 1° is called a *spherical degree*.

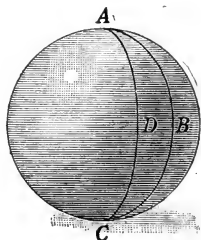
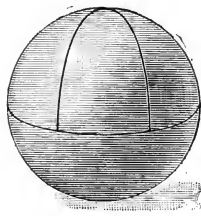

The spherical degree on a given sphere is taken as the unit of area in measuring the areas of figures on that sphere.

It should be noted that the number of square inches in a spherical degree depends on the radius of the sphere. Hence a given spherical degree is not a unit that can be used for all spheres.

665. Corollary. *A lune whose angle is n° contains $2n$ spherical degrees.*

QUERY 1. How many spherical degrees are there in a hemisphere?

QUERY 2. How many spherical degrees are there in the entire sphere?

QUERY 3. How many spherical degrees are there in a lune whose angle is (a) 1° , (b) 30° ?

QUERY 4. Is there any spherical triangle which contains three right angles? If so, how many spherical degrees does it contain?

666. Spherical excess. The number of degrees by which the sum of the angles of a spherical triangle exceeds 180° is called the *spherical excess* of the triangle.

QUERY 1. What is the spherical excess of a spherical degree?

QUERY 2. What is the spherical excess of a triangle all of whose angles are right angles?

QUERY 3. Why must the spherical excess of any triangle be less than 360° ?

QUERY 4. Why must the spherical excess of any triangle be a positive number?

EXERCISES

82. Construct a birectangular triangle containing 30 spherical degrees, giving a reason for each step.

83. Prove that two spherical degrees on two different spheres are in the same ratio as the square of the radii.

84. The area of a lune is to the area of the sphere as the angle of the lune is to four right angles.

85. How many square inches are there in a spherical degree on a sphere whose radius is 6 inches?

Theorem 20

667. *The area of a spherical triangle is equal to its spherical excess if the unit of area is the spherical degree.*

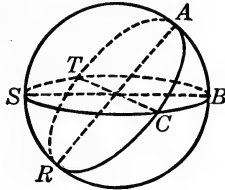

Given the spherical triangle ABC whose spherical excess is denoted by E .

To prove that the area of ABC is E spherical degrees.

Proof. Produce the sides of ABC so as to form three complete great circles.

$$\text{Lune } ACRB = 2 A \text{ spherical degrees.} \quad \S 665$$

$$\text{Lune } BCSA = 2 B \text{ spherical degrees.}$$

$$\text{Lune } CBTA = 2 C \text{ spherical degrees.} \quad \text{Why?}$$

$$\text{But} \quad \triangle CRS = \triangle BAT. \quad \S 644$$

$$\text{Now} \quad \text{lune } CBTA = \triangle ABC + \triangle BAT.$$

$$\text{Hence } \triangle ABC + \triangle CSR = 2 C \text{ spherical degrees.}$$

$$\text{Also} \quad \triangle ABC + \triangle CAS = \text{lune } BCSA = 2 B \text{ spherical degrees,}$$

$$\text{and} \quad \triangle ABC + \triangle CRB = \text{lune } ACRB = 2 A \text{ spherical degrees.}$$

Adding,

$$2 \triangle ABC + \text{hemisphere } CABSR = 2 (A + B + C) \text{ spherical degrees,}$$

$$\text{or } 2 \triangle ABC + 360 \text{ spherical degrees} = 2 (A + B + C) \text{ spherical degrees.}$$

$$\text{Hence } \triangle ABC = (A + B + C - 180) \text{ spherical degrees.} \quad \text{Why?}$$

$$\text{But} \quad A + B + C - 180 = E. \quad \S 666$$

$$\text{Therefore} \quad \triangle ABC = E \text{ spherical degrees.}$$

668. Corollary. *The area of a spherical triangle expressed in units of plane area is*

$$T = \frac{\pi r^2 E}{180},$$

where E and r denote the spherical excess and the radius of the sphere respectively.

HINT. The area of a spherical degree on a sphere of radius r is $\frac{4\pi r^2}{720}$.

EXERCISES

86. The area of a spherical triangle is to the area of the sphere as its spherical excess is to 8 right angles.

How many spherical degrees in the triangles whose angles are

87. $48^\circ, 123^\circ, 96^\circ$?

89. $90^\circ, 110^\circ, 167^\circ$?

88. $156^\circ, 197^\circ, 43^\circ$?

90. 75° each?

If the radius of a sphere is 6 inches, how many square inches in a lune whose angle is

91. 334° ?

93. $27^\circ 45'$?

92. 96° ?

94. $43^\circ 37' 30''$?

If the radius of a sphere is 8 inches, how many square inches in a triangle whose angles are

95. $86^\circ, 49^\circ, 135^\circ$?

97. $29^\circ, 150^\circ, 74^\circ$?

96. $128^\circ, 137^\circ, 196^\circ$?

98. $48^\circ 17', 89^\circ 15', 163^\circ$?

99. Find the angle of a birectangular triangle which is equal in area to a zone of one base whose altitude is one half the radius of the sphere.

100. What is the area of a spherical degree on the earth? ($r = 4000$ miles.)

REVIEW EXERCISES

101. Construct a line tangent to a sphere from an exterior point, giving a reason for each step.

102. A cubic foot of ivory weighs 114 pounds. Find the weight of a billiard ball $2\frac{1}{2}$ inches in diameter.

103. Two spheres of lead, of radii 2 and 3 inches respectively, are melted into a cylinder of revolution of radius 1 inch. Find the altitude of the cylinder.

104. The surface of a hemispherical dome whose diameter is 36 feet is to be covered with gold leaf which costs 15 cents per square inch. What must be paid for the gold leaf?

105. A spherical shell 2 inches thick has an outer diameter of 12 inches. Find its volume.

106. Find the volume of a sphere inscribed in a cube whose volume is 216 cubic inches.

107. Find the ratio of the surface of a sphere to that of its circumscribed right circular cylinder.

108. A wooden sphere weighs 200 pounds. Find the diameter of a sphere of the same material which weighs 50 pounds.

109. The diameter of one iron sphere is twice that of another. What is the ratio of their weights?

110. The area of a certain spherical triangle is 60 spherical degrees. Its angles are in the ratio 1 : 2 : 3. Find the angles of the spherical triangle.

111. Prove that two lunes on unequal spheres, but with equal angles, are to each other as the squares of the radii of the spheres.

112. Given a sphere. Find the ratio of the volume of an inscribed cube to that of a circumscribed cube.

113. Prove that the sphere inscribed in, and the sphere circumscribed about, a given regular tetrahedron have the same center, which is the point where the medians of the tetrahedrons meet.

HINT. See Exercise 133, Book VII.

114. If a square of side a lies with all its vertices on the surface of a sphere of radius r , how far from the center of the sphere is the plane of the square?

115. Prove that all of the planes which make equal sections of a given sphere are tangent to a sphere concentric with the given sphere.

116. In order to double the capacity of a spherical balloon, by what per cent must the area of the material in its surface be increased?

117. Find the ratio of (1) the surfaces, (2) the volumes, of a sphere and its circumscribed cube.

118. Through a fixed point P outside a sphere a variable line is drawn meeting the sphere in the variable points A and B . Prove that $PA \times PB$ is constant. Find the value of this constant in terms of r , the radius of the sphere, and d , the distance from P to the center of the sphere.

119. Four spheres 6 inches in diameter are placed in a square box whose inside dimensions are 12 inches. In the space between the first four spheres a fifth of the same diameter is placed. How deep must the box be so that the top will just touch the fifth sphere?

120. A ball 18 inches in diameter is placed in the corner of a room where the walls and the floor are at right angles. Find the diameter of another ball which will just fit back of the first one, touching the large ball, the walls, and the floor.

121. Using a method analogous to that of plane geometry, construct a spherical triangle each of whose sides is 60° .

122. Show that the attempt to construct a spherical triangle each of whose sides is 120° does not lead to a triangle.

123. Show that there is no plane section of a sphere and its inscribed cube which affords a great circle and an inscribed square.

124. Show that there are three plane sections of a sphere and an inscribed octahedron which afford a circle and an inscribed square.

125. Construct a sphere of given radius passing through three given points.

126. Prove that the six planes which bisect perpendicularly the six edges of a tetrahedron meet in a point.

127. Construct the sphere circumscribed about a given tetrahedron.

128. The diameter of the earth is 7960 miles. That of the sun is 860,000 miles. (1) Find the length of the earth's shadow. The distance of the moon is 240,000 miles. (2) Find the diameter of the earth's shadow at that distance from the earth.

129. If the moon moves 3 miles per minute with respect to the earth and its diameter is 2160 miles, what is the longest time that an eclipse of the moon can last?

130. Through a given fixed line construct a plane cutting a given sphere in (1) a great circle, (2) a small circle of prescribed radius, (3) a point.

131. Prove that the area of the zone of a sphere of radius r , which is illuminated by a point of light a distance a from the surface of the sphere, is $2\pi ar^2/(a+r)$.

132. The diameter of the earth is 7960 miles, and that of the moon is 2160 miles. Compare their volumes.

133. Find the area of the torrid zone if its width is 47° .

HINT. $\sin 23\frac{1}{2}^\circ = .398$.

134. What is the distance of the horizon on a calm sea from a point h feet in height, assuming that the line of vision is in a straight line?

135. The peak of Teneriffe is near latitude 30°N . The sun rising in the exact east shines on its summit 9 minutes before it shines on its base. How high is the mountain? (Compare the approximation found by this method with the exact height given in an atlas.)

136. Prove that in a spherical hexagon the sum of the interior angles is > 4 and < 8 right angles.

137. The sides of a spherical triangle ABC are 60° , 100° , and 80° respectively. How many degrees in the vertex angle of a birectangular triangle of the same area on the same sphere?

138. If the diameter of the earth is taken as 8000 miles, and the distance of the sun as 93,000,000 miles, what per cent of the total light and heat of the sun is received by the earth?



INDEX

- Angle, between line and plane, 352 ;
dihedral, 339 ; plane, 339 ; poly-
hedral, 419 ; trihedral, 420
- Bisector of dihedral angle, 345
- Cavalieri's theory, 369
- Circumscribed prism, 385
- Circumscribed pyramid, 418
- Circumscribed sphere, 449
- Cone, 405 ; axis of, 408 ; circular,
408 ; lateral area of, 412 ; of revo-
lution, 416 ; right circular, 408 ;
slant height of, 408 ; spherical,
460 ; volume of, 410 ; volume of
spherical, 461
- Cones, similar, 417
- Conical surface, 405
- Construction, operations of, 314 ; on
the sphere, 470
- Coplanar, 308
- Cube, 362
- Cylinder, 375 ; axis of, 381 ; circular,
375 ; of revolution, 381 ; volume
of, 378
- Cylinders, similar, 381
- Cylindrical surface, 375
- Diagonal, 363
- Dihedral angle, 339
- Distance, to plane, 337 ; on a sphere,
475
- Element, of cone, 405 ; of cylinder,
375
- Ellipse, 407
- Foot of a line, 324
- Given, meaning of, 306 (footnote)
- Great circle, 446
- Hemisphere, 448
- Hyperbola, 407
- Inscribed prism, 378
- Inscribed pyramid, 409
- Inscribed sphere, 449
- Intersection, 309
- Line, 305
- Line-segment, 305
- Lune, 485
- Pappus, Theorem of, 383
- Parabola, 407
- Parallel lines, 313
- Parallel planes, 313
- Parallelepiped, 362 ; right, 362
- Perpendicular, 325
- Perpendicular planes, 341
- Perspective, 308
- Plane, 305
- Plane angle, 339
- Polar distance, 471

- Polar triangle, 480
 Pole, 469
 Polyhedral angle, 419
 Polyhedron, 358 ; convex, 358 ; diagonal of, 363 ; regular, 424
 Prism, 358 ; oblique, 360 ; regular, 361 ; right, 360 ; right section of, 360 ; truncated, 361
 Prismatoid, 435
 Projection, of area, 352 ; of line, 349 ; of point, 349
 Proposition, converse, 334 ; direct, 334 ; opposite, 334
 Pyramid, 387 ; altitude of, 387 ; frustum of, 395 ; lateral area of, 387 ; regular, 399 ; slant height of, 399
 Pyramidal surface, 388

 Quadrant, 477

 Rectangular solid, 362
 Regular polyhedron, 424
 Regular prism, 361
 Regular pyramid, 399
 Right dihedral, 341

 Similar cones, 417
 Similar cylinders, 381
 Similar figures, 435

 Similar polyhedrons, 432
 Skew lines, 354
 Skew quadrilateral, 354
 Slant height, of cone, 408 ; of frustum, 401 ; of pyramid, 399
 Small circle, 447
 Sphere, 443 ; radius of, 443 ; tangent plane, 445 ; volume of, 443
 Spherical angle, 465
 Spherical cone, 460
 Spherical degree, 485
 Spherical excess, 486
 Spherical geometry, 464 ; restrictions on, 475
 Spherical polygon, 464
 Spherical sector, 460
 Spherical segment, 460
 Symmetric spherical triangles, 466
 Symmetric trihedrals, 431

 Tetrahedron, 397 ; regular, 399
 Triangle, bi-rectangular, 485 ; polar, 480
 Trihedral angle, 420
 Truncated, 361

 Undefined terms, 305

 Volume, of cone, 410 ; of cylinder, 378 ; of rectangular solid, 365

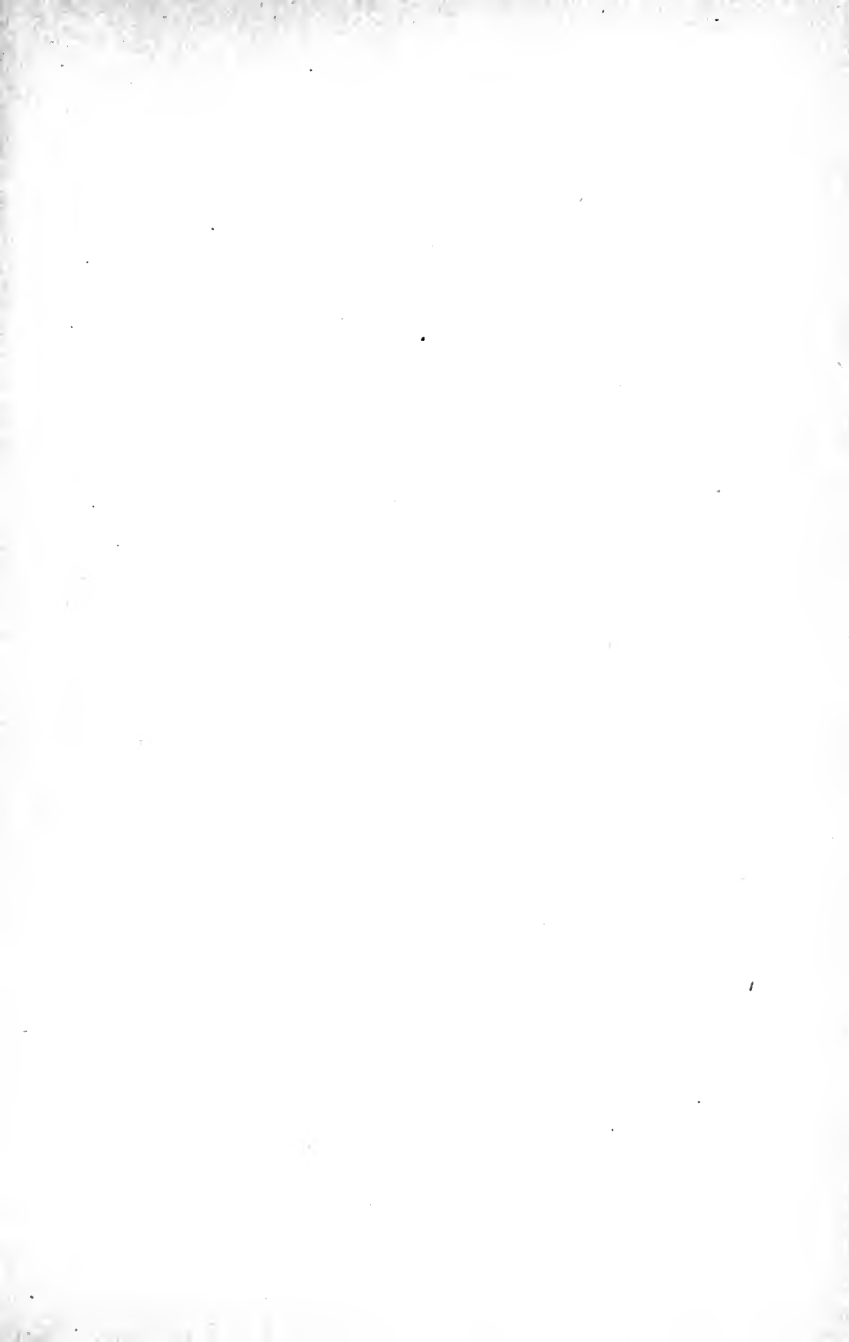

YB 17316

465

479

485

918337

QA457 .

H34

THE UNIVERSITY OF CALIFORNIA LIBRARY

