

Monographs on Physics

UC-NRLF



QB 50 837

THE SPECTROSCOPY OF
THE EXTREME ULTRA-VIOLET

THEODORE LYMAN

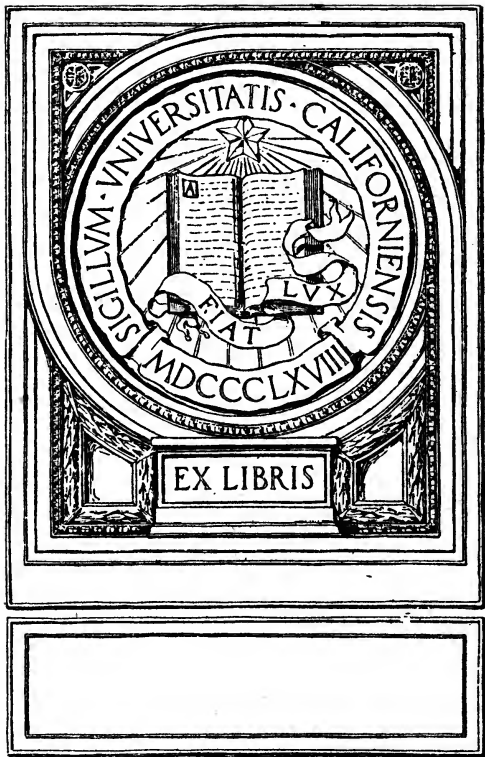



MONOGRAPHS ON PHYSICS

EDITED BY

SIR J. J. THOMSON, O.M., F.R.S.

AND

FRANK HORTON, D.Sc., M.A.

OF THE CAVENDISH LABORATORY, CAMBRIDGE

MONOGRAPHS ON PHYSICS.

Edited by Sir J. J. THOMSON, O.M., F.R.S., and FRANK HORTON,
D.Sc., M.A., of the Cavendish Laboratory, Cambridge.

8vo.

RAYS OF POSITIVE ELECTRICITY AND THEIR APPLICATION TO CHEMICAL ANALYSIS. By Sir J. J. THOMSON, O.M., F.R.S. 5s. net.

MODERN SEISMOLOGY. By G. W. WALKER, A.R.C.Sc., M.A., F.R.S., formerly Fellow of Trinity College, Cambridge. With Plates and Diagrams. 5s. net.

PHOTO-ELECTRICITY, THE LIBERATION OF ELECTRONS BY LIGHT; with Chapters on Fluorescence and Phosphorescence, and Photo-Chemical Actions and Photography. By H. STANLEY ALLEN, M.A., D.Sc., Senior Lecturer in Physics at University of London, King's College. 7s. 6d. net.

THE SPECTROSCOPY OF THE EXTREME ULTRA-VIOLET. By Professor THEODORE LYMAN, Jefferson Physical Laboratory, Harvard University, Cambridge, Mass. 5s. net.

ELECTRIC WAVES. By Professor G. W. PIERCE, Harvard University, Cambridge, Mass. *[In preparation.]*

THE EMISSION OF ELECTRICITY FROM HOT BODIES. By O. W. RICHARDSON, F.R.S., Wheatstone Professor of Physics, King's College, London. *[In preparation.]*

COLLOIDAL SOLUTIONS. By Professor E. F. BURTON, The Physics Department, The University, Toronto. *[In preparation.]*

ATMOSPHERIC IONIZATION. By Professor J. C. McLENNAN, Department of Physics, The University, Toronto. *[In preparation.]*

LONGMANS, GREEN AND CO.

LONDON, NEW YORK, BOMBAY, CALCUTTA, AND MADRAS.

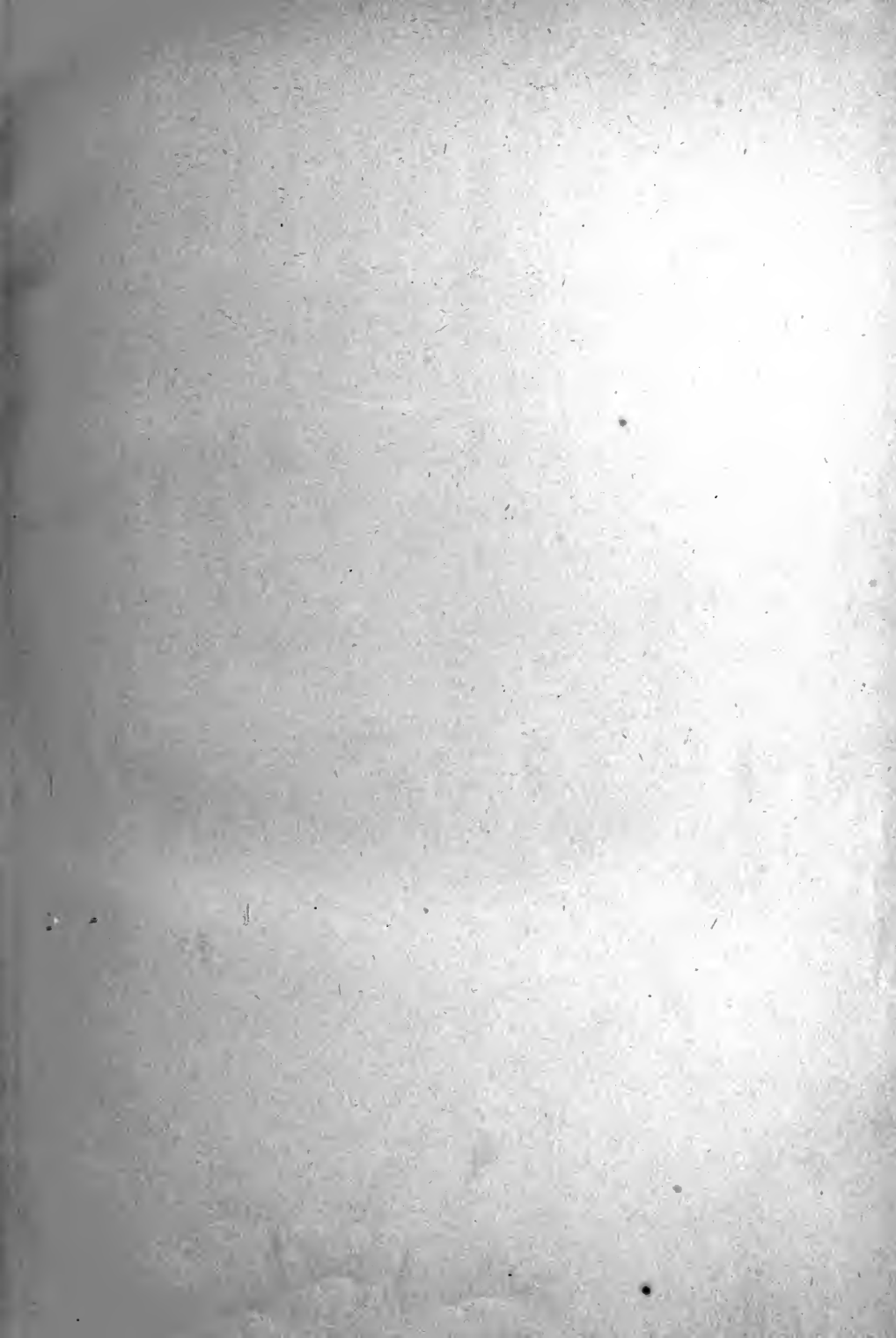

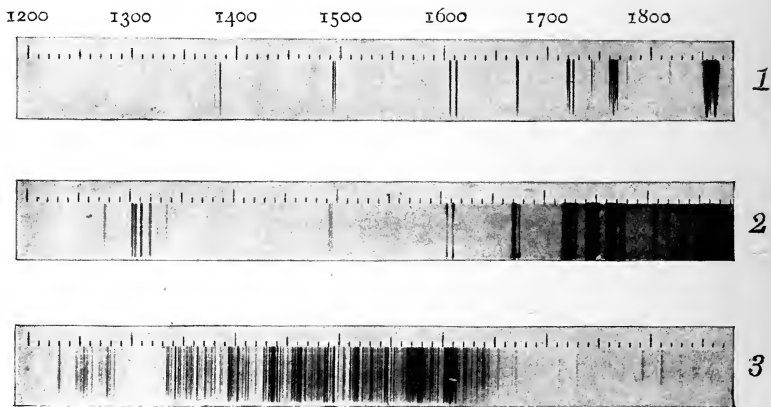

1. AL. SPARK IN HYDROGEN
2. AL. SPARK IN AIR
3. VACUUM DISCHARGE, HYDROGEN

THE SPECTROSCOPY OF THE EXTREME ULTRA-VIOLET

BY

THEODORE LYMAN, PH.D.

ASSISTANT PROFESSOR OF PHYSICS IN HARVARD UNIVERSITY

WITH DIAGRAMS



LONGMANS, GREEN AND CO.

39 PATERNOSTER ROW, LONDON

FOURTH AVENUE & 30TH STREET, NEW YORK

BOMBAY, CALCUTTA, AND MADRAS

1914

THE
MUSEUM OF
ART AND HISTORY
OF THE
CITY OF
NEW YORK

PREFACE.

THE title of this book might well have been "Spectroscopy of the Schumann Region," for it deals with that end of the ultra-violet spectrum where the absorption of air plays the determining rôle. The present title has been chosen, however, because a more extended field is necessary in order to trace the beginnings of those phenomena which become pronounced as the region beyond wave-length 2000 is explored. Thus, the absorption of the air begins to manifest itself in the ordinary ultra-violet, though it only becomes critical near wave-length 2000, and the absorption of many solids, usually considered transparent in the ultra-violet, begins to suffer a modification even before the region of shortest wave-lengths is reached. The book is, therefore, divided into two parts. The first and shorter portion deals with that part of the spectrum lying between wave-length 4000 and 2000; this is the region usually referred to as the ultra-violet. The second and longer portion treats of the spectrum on the more refrangible side of wave-length 2000; this is the extreme ultra-violet or Schumann region.

Some apology is due for a book whose scope is so limited. This apology must rest on the great importance which photo-electric, photo-chemical, and photo-abiotic processes have recently assumed. These effects may be observed in the ordinary portion of the spectrum, but they become much more pronounced in the Schumann region. For this reason, a knowledge of spectroscopic data, which facilitate the study of these phenomena in the extreme ultra-violet, may be considered of interest to the general scientific public.

CONTENTS.

	PAGE
Preface	v
PART I.	
Introduction	I
^{CHAP.} I. Photometry in the Ultra-violet	4
II. Absorption of Solids and Gases	11
PART II.	
I. Apparatus and Methods of Investigation in the Extreme Ultra-violet	29
II. Absorption of Solids and Gases	56
III. Emission Spectra of Gases	74
IV. Emission Spectra of Solids	88
V. Photo-electric and photo-abiotic phenomena. The Limit of the Spectrum	102
Tables	109
Bibliography	125
Appendix I.	129
Appendix II.	131
Subject Index	133

PART I.

INTRODUCTION.

THE violet limit of the solar spectrum observed with prisms and lenses of glass appears, to the normal eye, near the Fraunhofer H lines; that is to say, in the region of wave-length 4000, if the figure is expressed in Ångström units. Early in the history of spectroscopy, however, Ritter¹ showed by experiments with silver chloride that sunlight contained chemically active rays in the region beyond the violet, and Young² proved that these rays were of a shorter wave-length than those commonly observed with the eye. In 1842 Becquerel³ made a definite advance by employing a Daguerreotype plate to record the spectrum produced by a glass prism. He succeeded in obtaining pictures showing an increase in the length of the solar spectrum to the neighbourhood of a line which he called ρ , that is, to a wave-length of about λ 3400. At the same period, J. W. Draper⁴ also photographed the solar spectrum, employing a plane grating ruled on glass, in the place of the prism. The greatest stride in the region of the ultra-violet was made by Stokes,⁵ who, by using proper precautions, was able to follow the sun's spectrum to the line ρ with the eye, a result subsequently confirmed by Helmholtz.⁶ His most striking result was due, however, to the introduction of three new methods of observation. He substituted a fluorescent screen for the Daguerreotype plate, he replaced glass lenses and prisms by a system of quartz, and he used the light from an electric spark instead of the sun as a source. It seems probable that he observed the strong line in the aluminum spark spectrum near wave-length

¹ Kayser's "Handbuch," I, pp. 7 and 36.

² *Ibid.*, I, p. 36.

³ *Ibid.*, I, p. 38.

⁴ *Ibid.*, I, p. 39.

⁵ "Collected Papers," III, p. 401.

⁶ Kayser's "Handbuch," I, p. 71.

1850. This limit has only been surpassed in recent years. His papers are of such importance that the reader cannot do better than to consult them in the original.¹

The work of Miller² was contemporaneous with that of Stokes. He employed a photographic plate in place of the fluorescent screen, and, though his observations do not appear to extend to the farthest limit, yet his work is of interest since he noticed the transparency of water, quartz, and fluorite in the ultra-violet, and observed the transmission band of silver which has recently been so ingeniously employed by Wood.

From the year 1870 to the year 1890 there was no great advance in the knowledge of the spectrum on the more refrangible side of the limit set by Stokes, but during this period great strides were made in the spectroscopy of the ordinary ultra-violet. The subject of wave-length measurements early attracted attention. Even before the time of Fraunhofer, Young³ made determinations of this character, but it was not until nearly fifty years later that Esselbach⁴ measured the wave-length of some of the Fraunhofer lines by means of Talbot's bands. The first systematic work in this field was done by Mascart⁵ in 1863, while the beginning of the classic research of Ångström⁶ dates from about a year later. The invention by Rowland⁷ of the concave grating in 1882 enabled him to construct a map of the solar spectrum which surpassed in accuracy anything which had been previously produced and which yielded important standards of wave-length.

The attention which the ultra-violet received was largely due to the fact that the terrestrial sources of light, such as the arc and spark discharge, are particularly rich in radiations of a quality more refrangible than those which affect the human eye. It has resulted, from the activity in this field, that the spectra of the elements between wave-length 4000 and 2000 have been very carefully studied and the position of their lines has been accurately determined.

The limited character of the solar spectrum as compared

¹ "Collected Works," III, p. 267, and IV, p. 203.

² Kayser's "Handbuch," I, p. 103.

³ *Ibid.*, I, p. 7.

⁴ *Ibid.*, I, p. 71. ⁵ *Ibid.*, I, p. 109. ⁶ *Ibid.*, I, p. 110.

⁷ *Ibid.*, I, p. 121.

with the spectra obtained from various terrestrial sources early attracted attention. The cause of the phenomenon was studied by Crookes,¹ by Piazzi Smith,² and finally by Cornu.³ They attributed the limit of the solar spectrum to the absorption of the earth's atmosphere. This result was not only important in itself but it also was the indirect means of setting on foot work in the extreme ultra-violet. For Schumann⁴ having substituted fluorite for quartz, and having perfected a special kind of photographic plate, was stimulated by the researches of Cornu to construct his vacuum spectroscope. It was with this instrument that he discovered the region which bears his name.

It is to this region that the greater part of this work is dedicated.

In looking back over the foregoing paragraphs, it is at once obvious that the factors which have controlled our knowledge of the ultra-violet end of the spectrum are, first, the absorption of solids; second, the means by which the refracted light was detected; third, the character of the source, and fourth, the absorption of the constituents of the air. By way of introduction to the Schumann region, therefore, it will be well to pay special attention to the behaviour of these agents in the ultra-violet.

The classic works on spectroscopy require at the outset a detailed account of apparatus, but in the limited scope of the present volume it will be necessary to confine ourselves to those instruments which are not described elsewhere. Thus, as prism and grating spectroscopes are fully treated in many places as far as the ordinary ultra-violet is concerned, notably in Kayser's "Handbuch" and Baly's "Spectroscopy," it will not be necessary to mention them until the Schumann region is reached. On the other hand, since instruments for the comparison of the energy given by two sources of light in the ultra-violet are not quite so familiar to the scientific reader, and since the principles involved in them often permit their use in the extreme ultra-violet, we shall begin by some description of them.

¹ Kayser's "Handbuch," I, p. 45.

² *Ibid.*, I, p. 50.

³ *Ibid.*, I, p. 117.

⁴ *Ibid.*, I, p. 126.

CHAPTER I.

PHOTOMETERS.

THE PHOTOGRAPHIC PLATE.

THE function of all spectro-photometers may be divided into two distinct parts: the first consists in analysing the light from the sources into juxtaposed spectra, the second is concerned with the comparison of the relative intensity of the spectra so formed.¹ Spectro-photometers which are to be used in the ultra-violet must be provided with a dispersive system, especially adapted to the region, and with a mechanism for comparing intensities of the required sensibility.

The comparison of intensity may be carried out by one of three methods. First, by the use of a photographic plate; second, by the photo-electric cell, and third, by measuring the heat energy with a bolometer, a radiometer, or a thermo-junction.

When the dry plate is employed, the relation which connects the density of image with the intensity of the light and the time of exposure, is obviously of great importance. If i_1 is the intensity of the light which falls on the plate and i_2 the intensity of the light which leaves it, the opacity is defined as $\frac{i_1}{i_2}$ and the density or blackening is the logarithm of this quantity. So that if S is the density, $S = \log \frac{i_1}{i_2}$. The connexion between the intensity of the light and the time of exposure has been written by Schwarzschild. $I^p = \text{constant}$ where p is a constant, or very nearly a constant for normal illumination. Stark² has proposed the form $S = \log (kI^m t^p)$.

¹ Kayser's "Handbuch," III, p. 45.

² L. Geiger, "Ann. d. Phys.," 37, p. 68, 1912.

An excellent example of the simplest manner in which photographic plates may be employed in photometric measurements is afforded by the recent work of Fabry and Buisson¹ on the absorption of ozone. What follows is quoted almost word for word from the original article.

The only correct method of using photography is to attempt to produce two images of equal density on the same plate and with the same time of exposure. One of these images is produced by the light which has traversed the absorbing body under examination, the other is produced by light which has not suffered absorption but has been decreased in intensity in a known ratio. This ratio measures the amount of light transmitted by the body under examination.

In a particular case, which will serve as an illustration, the slit of the spectroscope was 1 mm. long and 0.5 mm. wide, thus the image of each ray in the spectrum of the mercury lamp, which served as a source, was represented by a small rectangle on the photographic plate. A single exposure with the absorbing medium in the light path was made on the same plate with numerous others without absorption but with successive decreasements of intensity, the time of exposure being the same in all cases. The weakening of the light was brought about by suitable rectangular diaphragms applied to the exit surface of the last prism of the spectroscope.

After the plate was developed, the opacity of each of the images for a given ray in the spectrum was measured by a microphotometer. This instrument was especially designed to examine small areas on a photographic plate.² The measurement was made by comparing the opacity of the image under examination with that of a calibrated wedge of glass. As one cannot hope that the image obtained through the absorbing medium will be found identical with one of the images obtained when the light has suffered a known weakening, it is necessary to seek by interpolation for the size which the diaphragm should have had in order to realize this equality. It is found that, if the logarithm of the intensity of the light which acts

¹ "Journal d. Physique," III, p. 196, 1913.

² Fabry and Buisson, "Comptes Rendus," 156, p. 389, 1913.

on the plate is plotted as abscissa (or the logarithm of the breadth of the diaphragm, which comes to the same thing) and the corresponding densities as ordinates, a straight line will result. By means of this straight line the necessary interpolation may be accurately carried out. Thus, it is possible to calculate what diaphragm should have been employed in order to secure an exact identity of photographic action. The net result of the process is to give the ratio of the intensities of the light after the beam has passed through the absorbing medium, to the intensity before it suffered absorption. The only assumption involved is that, if the time of exposure is kept constant, equal intensities produce equal effects.

Simon¹ has invented a spectro-photometer based on the same principles. In this instrument, the intensity of the light which has not suffered absorption is decreased in a continuous manner, while at the same time the photographic plate is moved in such a way as to receive an impression of correspondingly decreasing intensity. Recently the apparatus has been improved by Difregger.²

Henri and Wurmser³ have carried on spectro-photometric measurements by a method of equal densities. Here the time of exposure is varied until the density of the image produced by the direct beam is equal to that resulting from the light which has suffered absorption. The procedure involves a definite form of Schwarzschild's rule, namely, that $S = \log kI^n$, which, for the case of equal densities yields $\frac{I_1 k_1^n}{I_2 k_2^n} = 1$, a relation which, though not rigorously exact, is probably sufficiently accurate. In this method, as in the previous one, all the observations are recorded on the same plate.

If the intensities to be compared are recorded at different epochs on separate plates, no matter what care is taken to secure uniformity of development, some error may affect the result. Moreover, if the intensity of one beam of light is cut down by a revolving sector, the irregular illumination which

¹ Kayser's "Handbuch," III, p. 45.

² "Ann. d. Phys.," 41, p. 1012, 1913.

³ "Journal d. Physique," III, p. 305, 1913.

results may cause an error in Schwarzschild's rule which is difficult to correct.

A short account of the factors which control the density of the image on a photographic plate may be found in Chapter XI of Nutting's "Applied Optics." It is important to remember that the "chromatic sensibility of all ordinary plates is sensibly uniform throughout the ultra-violet and down through the violet and blue of the visible spectrum to about wave-length 5000." On the ultra-violet side we shall see that the sensibility rapidly falls off as the Schumann region is entered.

Before leaving the subject of photographic spectro-photometry mention must be made of an ingenious instrument described by Nutting,¹ in which the light from each of the two sources under examination is made to produce a system of interference bands. The arrangement is such that the bright bands of one system fall upon the dark bands of the other. When the intensities of the two sources are equal, the bands disappear. The method is not applicable in the extreme ultra-violet because of the absorption of the polarizing apparatus employed.

In the spectro-photometer employed by Krüss² a fluorescent screen replaced the photographic plate. The instrument does not seem to have been extensively employed. It is doubtful if the fluorescent ocular possesses any advantages over other forms of detectors in the ultra-violet. Diffuse light is troublesome, and the fluorescence of the lenses and prisms forms an added difficulty.³

PHOTO-ELECTRIC CELL.

The discovery by Herz in 1887 that, if a spark gap was illuminated by ultra-violet light, the passage of the spark was facilitated, led to the investigation of the phenomenon by Hallwachs.⁴ He showed that if a cleaned surface of zinc is charged negatively, the charge is quickly lost when the surface is illu-

¹ "Physical Review," 16, p. 129, 1903; also Königsberger, "Zeitsch. für Instrumentenkunde," 21, pp. 59, 129, 1901.

² *Ibid.*, 23, pp. 197, 229, 1903.

³ Hagen and Rubens, "Ann. d. Phy.," 8, p. 2, 1902.

⁴ "Wied. Ann.," 33, p. 301, 1888.

minated by ultra-violet light. This so-called photo-electric effect has been the subject of many researches. The magnitude of the phenomenon has been found to depend primarily upon the nature of the surface which is illuminated and upon the intensity and wave-length of the exciting light. It appears that many metals are particularly sensitive to the more refrangible end of the spectrum and that the electric current which may be obtained from a particular metal is proportional to the intensity of the light which falls upon it. These facts have led to the use of photo-electric cells in photometry and particularly in the ultra-violet region.

The exactitude of the proportionality between the current and the light intensity is obviously fundamental. It has been studied by several observers and has been confirmed for the alkaline metals by Elster and Geitel¹ for a considerable range of intensities. They employed a variety of sources, including a mercury lamp, but they did not analyse the light into its component colours. The spectral range was limited by the transparency of the "uviol" glass of which their cell was made. Recently the accuracy of their results have been questioned by Ives.² It seems certain that if great accuracy is required, one must proceed with caution.

Though the relation has not been tested for monochromatic light in the ultra-violet, it seems reasonable to believe that it holds, at least approximately, in the most refrangible part of the spectrum. However, before the matter can be considered settled, some experiments with monochromatic light of various wave-lengths beyond λ 3000 should be tried.

Kreusler³ was among the first to employ the photo-electric effect in ultra-violet photometric measurement. He used a spectrophotometer in which the light after analysis by a prism system fell upon a platinum button contained in a vessel filled with hydrogen at a pressure of 200 mm. This button was charged to a high negative potential, the current which flowed from it to a neighbouring anode was taken as a measure of

¹ "Phy. Zeitsch.," 14, p. 741, 1913; 15, p. 1, 1914.

² "Astrophysical J.," 39, p. 428, 1914.

³ "Ann. d. Phy.," 6, p. 412, 1901.

the intensity of the light which fell on the platinum. Kreusler checked the current-intensity relation for various parts of the spectral field in which he worked. He states that if care was taken not to charge the cathode too near the sparking potential, the relation held. He determined the absorption coefficient for a number of substances between λ 3000 and λ 1850.

Meyer,¹ in 1903, employed the apparatus of Kreusler to determine the absorption of ozone, a subject which will be considered in its place. Krüger and Moeller² in 1912 replaced the platinum button by a form of photo-electric cell which had been perfected by Elster and Geitel. In this arrangement a surface which receives the illumination is of potassium; it is enclosed in a vessel containing hydrogen or helium at a low pressure. Recently Hughes³ has described a sodium cell which is particularly well adapted to ultra-violet photometric work.

It appears that the photo-electric cell, because of its sensitivity, offers some important advantages over the ordinary photographic plate,⁴ if proper precautions are taken, for work in the ultra-violet.⁵ The selenium⁶ cell which has been used with advantage in photometric work in the visible, is probably too insensitive in the ultra-violet to be of much value.

MEASUREMENT OF HEAT.

The four instruments most commonly employed to measure the heat energy in the spectrum are, the bolometer of Langley, the radiomicrometer of Boys, the improved radiometer of Nichols, and the linear thermopile of Rubens.⁷ These instruments have been largely employed in the less refrangible part of the visible and in the infra red, because the maximum of heat energy for many sources lies in these regions. It was observed by Pflüger, however, that the spark and arc spectra

¹ Meyer, "Ann. d. Phys.," 12, p. 849, 1903.

² "Phy. Zeitsch.," 13, p. 729, 1912.

³ "Phil. Mag.," 25, p. 679, 1913.

⁴ Meyer and Rosenberg, "S.A. Vierteljahrsh. Astron. Gesell.," 48, p. 210,

1913.

⁵ "Phy. Zeitsch.," 15, p. 1, 1914.

⁶ "Proc. Roy. Soc.," A. V, 89, No. 608, p. 75.

⁷ Nutting, "Outlines of Optics," chap. ix; Coblentz, Bull. Bureau of Standards, Wash., 9, No. 1, p. 7.

of most metals possess sufficient energy in the ultra-violet to make their use possible.¹ If, therefore, the source is properly selected, some form of radiometer may be employed in photometric measurements even in the more refrangible region. The thermo-element of Rubens appears to be the smallest, simplest, and easiest to operate of all the radiometers, though even in its improved form it does not possess the sensibility of the bolometer or of the instrument perfected by Nichols.

A considerable number of investigators have used the thermopile in the ultra-violet. Hagen and Rubens² employed it in their work on the reflecting power of metals; their measurements extended to wave-length 2500. Pflüger³ studied the energy distribution in the spectra of various sources. He found the maximum of energy in the aluminum spark spectrum at λ 1860 and even obtained an indication of the energy of the aluminum spark in the Schumann region itself. He also⁴ employed the thermo-junction in a straight photometric investigation in which he determined the absorbing power of a number of substances.

Recently, the thermopile has been employed to measure the energy in photo-chemical and photo-electric researches in the ultra-violet. The recent work of Richardson⁵ affords a good example of such an investigation.

As an instrument for photometric measurement in the ultra-violet, the thermopile does not possess the simplicity of the photographic plate nor the sensitivity of the photo-electric cell. But, as its indications depend upon the energy which falls upon it without respect to wave-length, the results obtained with it are easy of interpretation.

¹ "Ann. d. Phys.," 13, p. 890, 1904.

² *Ibid.*, 8, p. 1, 1902.

³ *Ibid.*, 13, p. 890, 1904.

⁴ "Phy. Zeitsch.," 5, p. 215, 1904.

⁵ "Phil. Mag.," 26, p. 549, 1913.

CHAPTER II.

ABSORPTION OF SOLIDS.

SINCE transparency is a fundamental requisite of substances which are to be used for lenses and prisms in the ultra-violet, it is necessary to consider the absorption of the various materials available for such optical work. The ordinary kinds of glass, which serve so well in the visible, are not at all suited for the more refrangible part of the spectrum. In general, heavy flint glass is less transparent than light flint, and this, in turn, is less transparent than crown.¹ A thickness of 1 cm. of even the best of this last-named material absorbs very strongly indeed, in the region of λ 3100. Pfüger² has made accurate measurements with his thermo-junction photometer for a number of glasses down to wave-length 3570, and Krüss³ has carried the measurement farther with a spectrophotometer fitted with a fluorescent screen; the most transparent material which he investigated was a borosilicate crown, 1 cm. of this only permitted 8 per cent of the light to pass at wave-length 3090. The firm of Schott, at Jena, have turned their attention to the making of glass particularly transparent to the ultra-violet. Zschimmer has published some of the results attained in a series of papers. In one of these,⁴ the properties of three kinds of "uviol" glass are described and their behaviour relative to other forms of glass is illustrated by three spectrograms. It appears that a specimen of this new glass 1 cm. thick will transmit 50 per cent of the light at λ 3050, and if the thickness is reduced to 1 mm., 50 per cent is transmitted at λ 2800. For a thickness of 2 mm., the limit of the spectrum appears at λ 2850 for "uviol" flint,

¹ Kayser's "Handbuch," III, p. 377.

² "Phy. Zeitsch.," 4, p. 429, 1903.

³ "Zeitsch. f. Instrumentenkunde," 23, pp. 197 and 229, 1903.

⁴ *Ibid.*, p. 23, 360, 1903.

and λ 2800 for "uviolet" crown, whereas for English borosilicate crown, the limit is at λ 2970. To illustrate the transparency of the new glass for extremely thin layers, a spectrum taken through a common microscope cover glass is compared with one taken through a "uviolet" cover glass. In the first case the spectrum stops at λ 2850, in the second at 2480. It is interesting to note that Zschimmer has succeeded in making a glass which is quite transparent at λ 2800 but which absorbs in the visible blue.

In later papers Zschimmer discusses the relation between the physical properties of glass and their chemical constitution¹ and the relation between their transparency in the ultra-violet and their chemical constitution.² In this later paper, the author points out that boric oxide (B_2O_3) and silica oxide (SiO_2) in their pure state are very transparent even beyond λ 2000, that the addition of metallic oxides lessens the transparency, that sodium oxide (Na_2O) acts more strongly in this respect than potassium oxide (K_2O), and lead oxide very strongly indeed. It has since³ been shown that B_2O_3 is less transparent than quartz of equal thickness in the ultra-violet. Fritsch⁴ has described a glass composed of six parts commercial calcium fluorite (CaF_2) and fourteen parts of B_2O_3 which he tested and found transparent to wave-length 1850. No practical use seems to have been made of this substance, perhaps because it cannot be obtained in pieces of sufficient size and homogeneity.

It appears from what has just been said that, though the glasses manufactured by Schott offer a notable improvement over older forms, yet even they are not suitable if work is to be carried on in the extreme ultra-violet.

Among the substances which occur in nature in sufficiently large homogeneous masses to be of optical value and which seem to promise the necessary transparency are, Iceland spar, quartz, rock salt, and fluorite.⁵

¹ "Zeitsch. f. Electro. Chem.," 11, p. 629, 1905.

² "Physik. Zeitsch.," 8, p. 611, 1907.

³ Lyman, "Astrophysical J.," 28, No. 1, 1908.

⁴ "Phy. Zeitsch.," 8, p. 518, 1907. ⁵ Kayser's "Handbuch," III, p. 380.

The measurements of Pflüger¹ yield perhaps the most satisfactory data on these substances. Iceland spar is easily ruled out of court. In a thickness of 1 cm. for wave-length 2800, it absorbs 15 per cent; at wave-length 2140, 97 per cent. Quartz is a far more satisfactory substance. Pflüger found considerable differences to exist between various specimens. In general, more light was absorbed when the path was parallel to the axis than when it was perpendicular. For a piece 1 cm. thick he gives the following values:—

	λ 2220	2140	2030	1860
per cent absorbed	5·8	8	16·4	32·8

He found fused quartz far less satisfactory; a plate 2·8 mm. thick permitted nothing below λ 2000 to pass. It seems probable the effect was due to the presence of some impurity, for it will appear later that, though fused quartz is less transparent than the crystalline variety, yet it is possible to find specimens which are quite transparent to light of much shorter wave-length than λ 1850. Both Pflüger's measurements and some qualitative observations made by Schumann² tend to ascribe to crystalline quartz rather less transparency than it really possesses in the region below λ 1850.

The considerable differences in absorbing power observed with various specimens of fused quartz may account for the variation in efficiency which different investigators have obtained with the mercury arc in quartz when light of the very shortest wave-length was in question.

For rock salt, Pflüger gives 4·5 per cent absorption at λ 2800 and 30 per cent at λ 1860. Because of its high dispersion he recommends the use of rock-salt prisms protected from the action of the air by thin quartz plates cemented with glycerine. Such an arrangement is only useful on the less refrangible side of λ 2300 where the absorption of the cement does not enter. He gives the following values of the angle of refraction:—

λ	Fluorite.	Quartz.	Salt.
1850-2310	3° 5'	5° 40'	27° 10'
2310-3400	2° 20'	4° 20'	10° 10'

¹ "Phy. Zeitsch.," 5, p. 215. ² "Wien. Ber.," 102, IIa, p. 415, 1893.

Pflüger's values for the absorption of rock salt have led to the assumption that it is more transparent in the Schumann region than crystalline quartz. This is not the case; absorption very rapidly sets in on the more refrangible side of λ 1800.

Of all substances fluorite is the most transparent in the extreme ultra-violet; it is the only substance of which prisms and lenses can be constructed for work in the Schumann region. Pflüger states that at thickness of 1 cm. it absorbs 20 per cent at λ 1860. It appears that this estimate is rather too high. The greatest differences in transparency occur even among specimens of clear colourless fluorite. The whole subject will be treated in a later chapter.

Short tables giving the index of refraction for a variety of substances may be found in Baly's "Spectroscopy," p. 95 *et seq.*

ABSORPTION OF GASES.

In the ordinary part of the spectrum, the absorption of the air has little influence on terrestrial spectroscopic investigations, but when the Schumann region is reached, it plays the determining rôle. The first measurements of the air's opacity, however, were not made in the extreme ultra-violet and were not concerned with a terrestrial source. Ever since quartz apparatus and the photographic plate have been used in the study of the sun's light, it has been observed that its spectrum became suddenly weakened near λ 3000 and that all trace of it was lost at a point not much farther toward the violet.

Cornu¹ suspected that the extent of the spectrum depended on the absorption of the layer of air through which the rays passed, and that the limit receded toward the red as the thickness of the layer increased. To test his hypothesis, he made observations at Courtenet (alt. 170 m.), in which he took a succession of photographs of the solar spectrum with the sun at various altitudes above the horizon. His results may be illustrated by the following values:—

¹ "Comptes Rendus," 88, pp. 1101 and 1285, 1878; 89, p. 808, 1879; 90, p. 940, 1880; 111, p. 941, 1890.

Time.		Limiting Wave-length.	Time.		Limiting Wave-length.
hr.	min.	λ	hr.	min.	λ
10	30	2955	3	9	2990
0	2	2950	3	40	3045
1	18	2955	4	17	3045
1	50	2970	4	38	3070

He found that, if the limiting wave-length and the logarithm of the sin of the sun's altitude were taken as coördinates, these numbers yielded a straight line. The results were expressed by the empirical formula, $\sin h = .49 \times e^{-0.08330(\lambda - 300)}$ where h was the sun's angular distance above the horizon and where the wave-length was expressed in $\mu\mu$ ($1 \mu\mu = 10$ Ångströms). This relation clearly suggested the absorption of the atmosphere as the factor which limits the solar spectrum.

Cornu used these results in connexion with the theory in order to establish a general relation between the thickness of the absorbing layer and the last visible wave-length.¹ Starting with the relation $P = J_\lambda F(\lambda, t)$, where P is the intensity of photographic action, J_λ , the intensity of the light of wave-length λ , and $F(\lambda, t)$ is an unknown function of the wave-length and the time of exposure, he made use of the fact that, if light of intensity J_λ traverses a plane layer of thickness D and transparency A_λ , the resulting intensity J'_λ may be expressed $J'_\lambda = J_\lambda A_\lambda^D$, where D can be written $\frac{\sin h}{l}$. These two relations led to the expression $\frac{\sin h}{l} = \psi(w, T, \lambda)$, where l is the

thickness of the absorbing layer at the place of observation, w the photographic activity at the limit of the spectrum, and T the constant value of t used throughout the experiments. He then compared this theoretical equation with the empirical expression derived from experiments with the sun at various heights above the horizon. He was thus enabled to write an equation of the form $\frac{\sin h}{l} = \frac{M e^{-m(\lambda - \lambda_0)}}{l}$, where λ and λ_0 are the wave-lengths corresponding to thicknesses of the absorbing layers of air l and l_1 ; M and m have the values derived from experiment, namely, 0.49 and 0.08330. To put this

¹ Kayser's "Handbuch," III, p. 337.

relation in a practical form, it is necessary to note that l is proportional to the atmospheric pressure p where p varies with the height above sea-level according to the equation $p = p_0 e^{-\frac{z}{z_0}}$. The equation then takes the form $\sin h = M e^{-m(\lambda - \lambda_0) - \frac{z - z_1}{z_0}}$.

To learn the effect on the limit of the spectrum of increase in altitude of the observer, the exponent of e may be set equal to a constant, remembering that z_0 denotes the height of the atmosphere at sea-level, z_1 the height of the place of observation, and λ_0 the limit of the spectrum at sea-level, the relation $dz = -mz_0 d\lambda$ results, which becomes $dz = -0833x(7963 d\lambda)$ or $dz = -663.3 d\lambda$. The meaning of the equation being that, to increase the length of the spectrum by $1 \mu\mu$ or 10 Ångströms units, the observer must ascend 663.3 metres. Cornu¹ tested this relation by making observations at 660 metres and at 2570 metres. The results were not in exact accord with the formula, for he found an increase of $1 \mu\mu$ for every 868 metres in elevation. However, when he redetermined the value of the constant m at the altitude of 2570 metres from observations of the sun at various times of day, the empirical relation became $dz = 896.3 d\lambda$, an expression which seemed in good agreement with facts.

Equation 1 has also been employed by Cornu² to determine the limit of the spectrum which would be set by the absorption of a terrestrial air column of constant density. In this case, $\sin h$ may be considered as unity and the formula becomes

$$\frac{l}{l_1} M = e^{m(\lambda - \lambda_0)}$$

His calculations indicate that it would require 10 metres of air to cut off the spectrum at $\lambda 2118$; 1 metre at $\lambda 1842$, and 10 cm. at $\lambda 1566$. As a matter of fact, these results are not in agreement with experiment. As will be shown presently, the absorbing action of the air cannot be represented at all in the region between $\lambda 2200$ and 1800 by Cornu's formula.

For some time the investigations which have just been

¹ Loc. cit.

² "Comptes Rendus," 89, p. 808, 1879; 111, p. 941, 1890.

described were interpreted to mean that the limit of the solar spectrum could be entirely explained by the absorption of an homogeneous atmosphere whose density was distributed according to the barometric law. The recent work of Miethe¹ and Lehmann may modify this conclusion. They determined the limit of the solar spectrum at various altitudes from near sea-level to 4560 metres with an instrument in which the photographic plate was most carefully protected from the action of stray light. They arrived at the startling result that the position in the spectrum of the last trace of light action was independent of altitude. The following numbers exhibit their data:—

Place.	Altitude. Metres.	Limit. λ
Assuan	116	2915.5
Berlin	50	2912.6
Zermatt	1620	2913.6
Gornergrat	3136	2911.0
Monte Rosa	4560	2912.1

They observed that, although the position of the last light action does not change with the altitude, the distribution of intensity near the end of the spectrum suffers some modification. Thus, by an increase of 900 metres above the altitude obtained by all previous observers, they succeeded in photographing two lines, λ 2919.8 and λ 2916.7, which, though they lay in the region within the extreme limit, had never been seen before. This change of intensity in the region near the end of the spectrum was the phenomenon studied by Cornu and to which his equations still probably apply.

Their conclusion that the last trace of light action is independent of altitude has been confirmed by Wigand.² He employed the same spectroscope as Miethe and Lehmann, and, by means of a balloon, he reached a height of 9000 metres and maintained his position for two hours. At this extraordinary altitude the last trace of the sun's spectrum occupied the same position on the photographic plate as it did on the earth's surface at Halle. At 9000 metres the observer has

¹ "Ber. Berlin Akad.," 8, p. 268, 1909.

² "Phy. Zeitsch.," 14, p. 1144, 1913.

about $\frac{2}{3}$ of the mass of the air under him. It is evident, therefore, that the absorbing agent must either possess an extremely steep absorption curve or reside in the very uppermost layers of the earth's atmosphere. It is also possible that the effect is due to a different agent from that which produces the fluctuations of intensity observed by Cornu. This agent may even be situated in the sun's atmosphere. The limit found by Wigand for the last trace of light was λ 2897; the fact that this limit was somewhat below that observed by Miethe and Lehmann is due to a colour screen which lessened fog and so permitted more exact measurement.

In the summer of 1912, Dember¹ made observations with a quartz spectrophotometer, fitted with a photo-electric cell, at an altitude of 4560 metres. He states that the last action of the sun's rays was at λ 2800. He attributes the gain of nearly 100 units over the limit obtained by other observers to the superior sensitiveness of the photo-electric cell over the photographic plates. Owing to the unfavourable weather conditions, his observations were all made in a day and a half, and it is not perfectly certain that scattered light was completely eliminated. The results appear to need confirmation.

In considering the relative importance of the various constituents of the atmosphere as judged by their absorbing power in the ultra-violet, carbon-dioxide and nitrogen may be discarded at once, for they appear to be practically transparent in the ultra-violet.² Water vapour cannot be dismissed quite so easily, though its small absorption in the ultra-violet renders it improbable that it is an important factor in determining the limit of the solar spectrum.

The activity of oxygen as an absorbing agent is very great in the region under consideration. Liveing and Dewar³ as long ago as 1888 made experiments with a tube 18 metres long filled with "ordinary oxygen." They raised the pressure of the gas to 90 atmospheres in some of their experiments and observed that, under these circumstances, all light of

¹ "Abhand. Nat. Wiss. Gesell.," "Isis," Dresden, 2, p. 1, 1912.

² Kayser's "Handbuch," III, p. 353.

³ "Phil. Mag.," 26, p. 286, 1888.

wave-lengths shorter than λ 3360 was cut off. A tube of oxygen of 18 metres with the pressure of 90 atmospheres gives about the same mass of the gas as is contained in the atmosphere, but they noted that the intensity of the absorption bands in the visible produced by the compressed gas was far greater than that of the corresponding bands in the solar spectrum with a low sun; the limit of the spectrum is also considerably higher than that obtained by Cornu in the afternoon, i.e. λ 3070. One might conclude from this, either that part of the absorption which they observed was due to some impurity in their gas, or that the oxygen in the air is not uniformly distributed. The latter supposition is equivalent to saying that their experimental tube contained more oxygen than exists between an observer at sea-level and the sun. It is also possible that oxygen at this point in the spectrum does not obey Beer's Law, that is to say, the absorption is not a function of the product of the pressure and the gas path.

In connexion with what is to be presently considered, it is interesting to note that Liveing and Dewar tried oxygen in a tube 165 cm. long at pressures of 85 and 140 atmospheres and attempted to find the extreme-ultra-violet limit of the absorption band, but though they searched the spectrum to the region of λ 2320, they could find no sign of a transmission of light. The limit of the spectrum with 85 atmospheres pressure was λ 2664; with 140 atmospheres, λ 2704.

In spite of the strong absorption of oxygen some investigators have preferred to ascribe the limit of the spectrum to the action of ozone.¹ It has long been known that ozone possesses a strong absorption band in the very region under examination.² Quantitative measurements of this band have been made by Meyer³ with the photo-electric arrangement of Kreuzler already referred to, by Krüger⁴ and Moeller with a photo-electric cell, and recently by Fabry⁵ and Buisson by the photographic method already described. The results of

¹ Kayser's "Handbuch," III, p. 361. Hartley, "Nature," 39, p. 474, 1889.

² Ladenburg and Lehmann, "Ber. Deutsch. Phy. Gesell.," 4, p. 125, 1906.

³ "Ann. d. Phy.," 12, p. 849, 1903. ⁴ "Phy. Zeitsch.," 13, p. 729, 1912.

⁵ "Journal d. Phy.," 3, p. 196, 1913.

Krüger and Moeller do not agree at all well with the other observers, but the values for the coefficient of absorption a defined by the relation $J = J_0 10^{-ak}$, obtained by Meyer, are in fair agreement with those of Fabry and Buisson at least in the region between λ 2300 and λ 2700. The values are shown plotted in Fig. 1. It appears that at λ 2600 the ratio of the values of Meyer to those of Fabry are as 126 to 120, at λ 2700 as 116 to 91; at longer wave-lengths the ratio is greater, for λ 2900, as 38.6 is to 16, and at λ 3000 as 30 is to 4.6. The

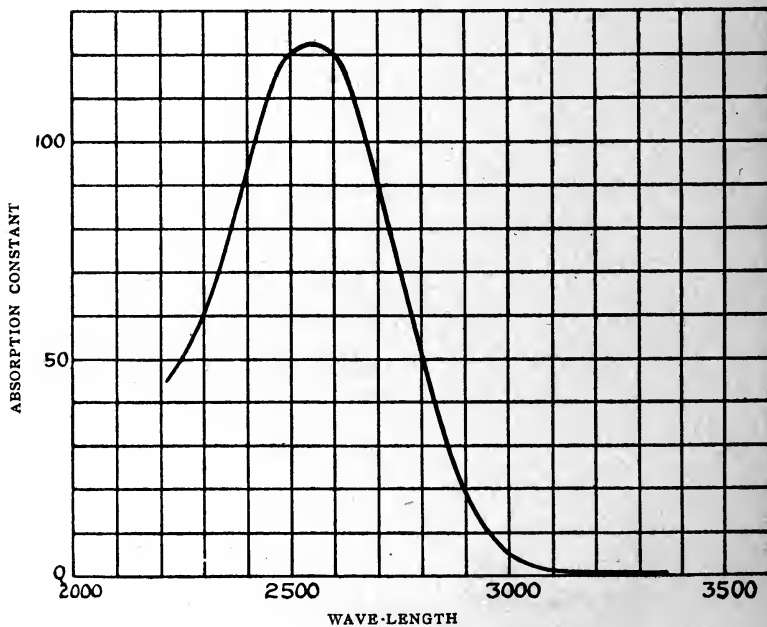

FIG. 1.

fact that Meyer's photo-electric arrangement was comparatively insensitive in the region of longer wave-lengths while the photographic plate is particularly efficient in this region, makes it probable that the values of Fabry and Buisson are the better of the two for the less refrangible part of the curve.

Both the observers have applied their data to the problem of the atmospheric absorption. Fabry and Buisson have shown that their relation between the absorption coefficient and the wave-length in the region between λ 2900 and λ 3300 may be transformed into a relation connecting the last visible wave-

length and the absorbing thickness, identical in form with that deduced by Cornu from his best experiments on the sun at various hours of the day, and that, not only is the form of the equation the same, but the coefficients which determine the change of the spectral limit with change in altitude are of the same order of magnitude in both cases, the values being 177 and 200. They infer from this agreement that the absorption phenomena observed by Cornu are due to the presence of ozone in the earth's atmosphere.

They have calculated the amount of ozone per cubic metre which would be necessary to produce the absorption observed near the end of the solar spectrum. In order to carry out such a determination, it is necessary to know what proportion of the sun's light of a given wave-length is absorbed before it reaches the earth. Fabry and Buisson, using their photographic photometer, have arrived at the result that the transmitted light at λ 3000 is of the order of $\frac{1}{100}$ of the whole. They have published no details of their method, and they state that the result is only approximate. To produce this degree of absorption at this particular point in the spectrum, they estimate the atmosphere must contain a quantity of ozone equivalent to a layer 5 mm. thick of the pure gas at 760 mm. pressure. If this quantity of ozone were uniformly distributed throughout the atmosphere, the quantity per cubic metre would be 0.6 cub. cm. Now, Fabry states, that experiments on the ozone content of the air on the earth's surface give results of the order of 0.008 cub. cm. per cubic metre; in other words, if this value near sea-level represents the ozone content throughout the atmosphere, then the limit of the sun's spectrum cannot be ascribed to the action of this gas, for seventy-five times more ozone is needed to produce the observed result than is actually found in the air near the earth. One must conclude, either that ozone is not the determining factor, or that it is not uniformly distributed but occurs in greater quantities in the upper portions of the atmosphere. The recent results of Pring¹ tend to modify this conclusion. At an altitude of $3\frac{1}{2}$ kilometres he finds a concentration of about five parts of ozone in a million

¹ Pring, "Proc. Roy. Soc.," A. 90, A. 617, p. 204.

of air. If the equivalent atmospheric height contained this concentration throughout, it would correspond to a layer of pure ozone 4.2 cm. thick. Such a layer is more than eight times thicker than that required by Fabry to produce the absorption he observed. It is obvious, therefore, that even if the average concentration of ozone in the atmosphere is considerably less than that found by Pring at $3\frac{1}{2}$ kilometres, there is enough ozone present to account for the limit of the solar spectrum.

Meyer has made calculations, based upon his data on the absorption coefficient of ozone, of a similar character to those of Fabry. As his value of the coefficient at λ 3000 is about six times that of the French observers, it is obvious that, according to his figures, even less ozone per cub. cm. would be required to produce a given amount of absorption than that needed if Fabry's numbers were employed. However, Meyer's figures in no way explain the facts if the ozone is considered as uniformly distributed, for, according to his results, 58 per cent of the sun's light should be transmitted at λ 2900. We have seen that his value of the constant a is probably in error at λ 3000 because of the lack of sensitiveness of his apparatus in this part of the spectrum.

There is another important and interesting agency which may influence the extent of the solar spectrum, namely, the scattering effect of the molecules of the air. The percentage of light transmitted through a gas layer of thickness H containing N molecules per cub. cm. is given by the expression e^{-KH} where K is given by Rayleigh's formula

$$K = \frac{32\pi^3 (\mu - 1)^2}{3 N\lambda^4}.$$

Schuster¹ used these relations to compute the percentage of light transmitted for various wave-lengths, and arrived at a set of values for the visible spectrum in good agreement with the numbers for the transmission of the air obtained by Abbot on Mount Wilson on a clear day. He concluded that for the visible spectrum, with the exception of a slight indication of selective action in the red and yellow, atmospheric absorption

¹ "Theory of Optics," p. 325.

is practically accounted for by the scattering of the molecules of the air.

The treatment has recently been considerably extended. King¹ has improved the formula for molecular scattering and has applied it to the experimental data with an excellent agreement between theory and observation. Fowle,² having introduced a correction for the action of water vapour, has applied King's formula to the most recent data for the transmission of the atmosphere and has also obtained excellent agreement to λ 3700. The experimental figures for these comparisons are obtained at such stations as Mount Wilson and Mount Whitney, which, on account of elevation above sea-level, are free from the complicating action of dust.

When the region at which the solar spectrum actually ceases is reached, the formula of King does not appear to yield results consistent with the facts, for at λ 2900 in dry, dust-free air containing no ozone, the transmission conditioned by scattering alone is about 60 per cent. Moreover, the experimental results of various observers are puzzling. Abbot³ estimates the transmission at Mount Whitney as 58 per cent for λ 3250, and his measurement at Bassour and at Mount Whitney for wave-length 3060 is about 70 per cent. He attributes this very high value to error caused by stray light, but even with this correction, it is very difficult to reconcile this result with the 1 per cent transmission obtained by Fabry and Buisson at λ 3000.

If the scattering action of molecules is to account completely for the transmission of the atmosphere in the region in which the solar spectrum is known to cease, it becomes necessary to assume that the agency which causes the extinction of the solar spectrum is of solar origin; this hypothesis seems untenable.

On the other hand, if the limit of the spectrum is of terrestrial origin, it must be produced by the selective absorption of some gas. The results of Miethe and Lehmann show that

¹ "Phil. Trans. Roy. Soc. Lond.," A., 212, p. 375, 1913.

² "Astrophysical Journal," 38, p. 392, 1913.

³ "Ann. Astrophy. Observatory of the Smithsonian," III, Tables 45, 46, 47. Also "The Solar Constant of Radiation," "Science," 39, p. 335, 1914.

either the absorption curve of the gas in question rises with extreme steepness on its less refrangible side, or that the gas is confined to the upper portions of the atmosphere. Oxygen cannot satisfy the second condition, and, as experimental data is wanting, it is impossible to say what the nature of its absorption band may be in the region near λ 3000. Ozone has an absorption band with a steep side and in the correct position. Moreover, the results of Pring indicate that its concentration is sufficient to produce the observed absorption on the assumption of uniform distribution.

Turning from the sun to terrestrial sources of light, it has been stated at the beginning of the chapter that the air in such thicknesses as are usually present in spectroscopic apparatus exerts no appreciable absorption in the ultra-violet. When the region on the more refrangible side of λ 2000 is entered, however, this statement no longer holds true. Schumann¹ showed that a very strong absorption sets in near λ 1850. Up to this point the transparency is greater than that predicted by Cornu but beyond that wave-length it is far less. The whole matter will be considered in detail in a later chapter; for the present, it will suffice to state that oxygen has been shown to be the active agent involved, the result being due to an unsymmetrical band extending from the region at λ 1900 to the neighbourhood of λ 1300. So steep is the rise of this absorption that while the line λ 1940 may be photographed through 14 metres of air, the region beyond λ 1750 is entirely absorbed by an air column 1 cm. long. The change of the absorption coefficient with wave-length has not been determined for this interesting oxygen band. The only numerical data are those of Kreuzler² who found that a column of air 20 cm. long absorbed 8.8 per cent at λ 1860, while at λ 1930 no absorption could be detected.

The relation of the absorption of oxygen in the neighbourhood of λ 3300 observed by Liveing and Dewar with a long column at a very high pressure to the strong absorption of the gas in the Schumann region in short columns at atmospheric

¹ Kayser's "Handbuch," III, p. 338.

² "Ann. d. Phys.," 6, p. 412, 1901.

pressure, is an interesting question. The effects observed may be due to two separate bands, in which case a region of relative transparency may exist between them. On the other hand, the extinction of the spectrum near λ 3300 may be produced by a shoulder of the absorption band whose maximum lies in the region of extremely short wave-lengths.

Meyer, who believed that ozone was the dominating factor in the region between λ 3000 and λ 2000, suggested that a place of relative atmospheric transparency might be expected in the neighbourhood of λ 2100, since near this point the absorption of ozone sinks to a very small value. He tried to detect the presence of solar radiation in this region by making experiments at a considerable altitude with his photo-electric photometer, but his results were inconclusive. The idea is a suggestive one and the fact would be most important if it could be proved. The data available, however, seem all unfavourable. Owing to the large proportion of oxygen in the atmosphere, it would be necessary for the absorption of this gas to sink to a very small value near λ 2100. Moreover, the loss by scattering is great. Again, it is doubtful if the sun gives much of any radiation of the required wave-length.¹ Notwithstanding the discouraging prospect, an experiment with a quartz or fluorite spectrograph using plates specially sensitive to the region in question would perhaps be worth trying.

REFLECTING POWER OF METALS.

The use of mirrors and reflecting gratings in the ultra-violet makes measurements of the reflecting power of metals in the more refrangible part of the spectrum of great importance.

Hagen and Rubens² employed a direct photometric method in which the beam after reflection from the surface under examination, was compared with the beam which had not undergone reflection. As has been already mentioned, they used a thermopile as the detecting instrument. The angle of incidence was about one degree; an arc served as source; the ultra-violet limit was at wave-length λ 2500. These results may be summarized as follows:—

¹ "Ann. d. Phy.," 12, p. 849, 1903.

² *Ibid.*, 8, p. 1, 1902.

A fresh silver mirror reflects excellently in the visible, falls to a sharp minimum of about 4 per cent at λ 3160, and then rises to 34.1 per cent at λ 2510; the trend of the curve is upward at this point.

The reflective power of platinum is steadily downward throughout the whole spectrum; it reaches 33.8 per cent at λ 2510. If the curve held its direction, about 28 per cent reflection might be expected at λ 2000. Gold sinks to a broad minimum between λ 3500 and λ 4000; it reflects 38.8 per cent at λ 2510. The curve appears to be rising at this point.

The curve for copper is roughly similar to that of gold. The minimum of reflection is thrust toward the violet, but 25.9 per cent of light is reflected at the more refrangible limit and the upward slope of the curve in the extreme region is small.

Nickel and iron resemble platinum; they both decrease steadily in reflecting power from the limit of the visible; they reflect 37.8 per cent and 32.9 per cent respectively at wave-length 2510.

Among alloys, Mach's Magnalium (69 Al + 31 Mg) shows a constant and high reflecting power of about 83 per cent out to the limit of the visible. From there, it falls to 67 per cent at the experimental limit and the tendency of the curve is downward. It possesses a much higher reflecting power than any other known substance in the neighbourhood of wave-length 2500; it is also distinguished by the permanence of its surface.

Schröder's Alloy No. 1 (66 Cu + 22 Sn + 12 Zn) and Schröder's Alloy No. 6 (60 Cu + 30 Sn + 10 Ag) closely resemble each other: they both reflect about 60 per cent at the limit of the visible and then fall off steadily to about 40 per cent. The curves tend rather sharply downward.

Brandes-Schünemann's Alloy (41 Cu + 26 Ni + 25 Sn + 8 Fe + 1 Sb) reflects but 50 per cent at the limit of the visible and 35.8 per cent in the extreme violet. Finally, Ross's Alloy (68.2 Cu + 31.8 Sn) reflects 56.4 per cent at wave-length 4000, and 29.9 per cent at wave-length 2500. So steep is the slope that a reflective power of less than 18 per cent might be looked for at wave-length 2000 if the curve

maintained its downward course. It is extremely important to note, however, that the Brashear Alloy used for the deflecting grating with which the spectrum has been pushed to the extreme limit of the Schumann region, resembles that of Ross. It seems likely, therefore, that the reflection curve for Ross alloy suffers a minimum and then rises again in the region of extremely short wave-lengths. At all events, it is evident that it is not safe to predict the behaviour of metals in the Schumann region from data obtained on the less refrangible side of wave-length 2500.

The condition of the polarization of the light reflected from metallic surfaces may be determined by the measurement of two quantities, the relative phase retardation and the ratio of the amplitudes of the two components vibrating at right angles to each other. A knowledge of these quantities permits the index of refraction and the coefficient of absorption to be calculated, and these, in turn, may be so combined as to yield the per cent of light reflected at normal incidence.

The method devised by Voigt rests on procedure of this kind.¹ It was used first by Minor² and more recently by Meier.³ The former carried the work as far into the ultra-violet as λ 2265. He studied steel, cobalt, copper, and silver. The data for steel show a fair agreement with the numbers of Hagen and Rubens. For silver, the agreement is all that could be expected when the differences introduced by the condition of the surface are borne in mind. It is interesting to note that Minor finds a decreasing reflective power for silver beyond the region of λ 2500; thus, at this wave-length 25 per cent is reflected, at wave-length 2265 only 18 per cent is reflected.

Meier determined the optical constants of gold, nickel, iron, platinum, bismuth, zinc, selenium, mercury, iodine, a silver copper alloy, and "Wood's fusible bismuth alloy." He followed the spectrum to wave-length 2573. The differences between his values and those of Hagen and Rubens are quite considerable in the ultra-violet, a fact which perhaps may be

¹"Phy. Zeitsch.," 2, p. 303, 1901.

²"Ann. d. Phys.," 10, p. 581, 1903.

³*Ibid.*, 31, p. 1017, 1910.

attributed to differences in surface conditions. For example, with gold he finds 27·6 per cent at the spectral limit as against 38·8 per cent obtained by the direct method; for platinum, 37·1 per cent as against 33·8 per cent; for nickel, 30·7 per cent as against 37·8 per cent. Meier followed the reflective power of mercury only to wave-length 3255. At this point he obtained 65·7 per cent. It is interesting to note that for "Wood's alloy" (exact composition not given) he obtained a higher reflective power in the extreme ultra-violet than from any other metal which he studied, namely, 56·6 per cent at wave-length 2749 and 52·7 per cent at 2573. As the alloy appears to be easily prepared these figures may be of practical importance.

PART II.

CHAPTER I.

OUR knowledge of the most refrangible end of the spectrum is chiefly due to the work of one man. Before entering on an examination of the region, therefore, it seems appropriate to give an account of its discoverer.

Victor Schumann was born near Leipzig in the year 1841. He received his early education at Leipzig; from 1860 to 1864 he was at the Gewerbeschule at Chemnitz. It must have been during this period that he acquired that extraordinary mechanical technique which characterized all his scientific work. For a time he was employed as a designer, later he was engaged in the manufacture of machinery for the book industry; finally, he became a partner in a machine business in which he remained actively engaged until 1892, and by means of which he was able to accumulate the funds which he later spent in scientific work.

He was more than forty years of age before he was able to turn from his business to scientific pursuits. Even then his investigations were conducted in the evening or at such odd moments as he could spare from his regular profession. Photography first attracted him; one of his earliest papers published in 1885 is on the sensitization of photographic plates. Almost immediately after this, however, he took up the pursuit of spectrum analysis, to which he devoted himself for the remainder of his active life. His first paper on the spectrum of hydrogen and upon the effect of the presence of impurities on the spectrum of mercury appeared in 1886. He must have been inspired by the idea of penetrating into the region of the extreme ultra-violet at the very beginning of his scientific studies, for it was but four years later that the article which marks the beginning of his attack on the region of the most refrangible rays appeared.

Guided by the work of Stokes, Soret, and Miller, he began by instituting a very careful comparison of the relative advantages of fluorite and quartz, and becoming convinced of the superiority of fluorite as a transparent medium for rays of the shortest wave-length, he employed this substance for his prisms and lenses. Thus equipped, he followed the spark spectra of more than twenty metals to the region of λ 1820 Ångström units. He next set himself the problem of determining the factors which caused the common limit in the spectrum of so many substances. His knowledge of photographic phenomena led him to recognize the part played by the absorption of gelatine, while his familiarity with the work of Cornu drew his attention to the absorption of the air. He put these ideas to the test by the construction of a vacuum spectroscope and by the use of special photographic plates whose emulsion was nearly free from gelatine. His efforts were almost immediately crowned with success, for a very considerable extension of the spectrum followed the use of the new apparatus. Brief accounts of this work appeared between 1890 and 1893, while a more detailed description of these researches was published in the Proceedings of the Vienna Academy in the latter year. It was during this period that Schumann gave up his business interests to devote himself entirely to his spectroscope. During the next ten years he went steadily forward, accurately and surely adding one improvement to his method after another as the results of experiments showed the way, until he finally arrived at the limit of the spectrum set by the absorption of fluorite, near λ 1200 Ångström units.

But as early as 1897 his health began to give way. Never of a robust constitution, he had submitted to considerable privations in early life in order to obtain the funds for the purchase of books. He undoubtedly still further undermined his constitution by the arduous labours entailed in the construction of his apparatus. In 1903 he was forced to give up nearly all experimental work. He died on 1 September, 1913. A complete list of his papers is given in Appendix I.

APPARATUS.

A detailed description of Schumann's vacuum spectro-scope, illustrated by excellent drawings, is to be found in the Smithsonian Contribution, No. 1413, and a somewhat shorter account is contained in Baly's "Spectroscopy." To repeat in full what is readily accessible in print seems superfluous; a statement of the chief features involved in the instrument will be sufficient for the purpose in hand. Schumann's apparatus¹ consisted of a prism spectro-scope of the usual form enclosed in an airtight casing of such ingenuity of design and perfection of workmanship that the necessary optical and mechanical adjustments could all be carried on without admitting air to the apparatus. The manipulations necessary to bring an ordinary quartz spectro-scope into adjustment for the ultra-violet are sufficiently tedious, but the rapid rise of the index of refraction of fluorite with decrease in wave-length makes such work increasingly difficult after the region of the most refrangible rays is reached. The following considerations will make this clear: In order to cover the extent of the spectrum with which Schumann was concerned, nine distinct photographic fields were ultimately necessary; to secure perfect definition in any one of these fields at least eight independent adjustments were required. The only test for the accuracy of any one of these eight adjustments was by means of the photographic plate. It is obvious, therefore, that before even a single photographic field could be brought to perfect definition, a great many spectrograms had to be taken. The delay of admitting the air and repumping the apparatus after each of these spectrograms would have been intolerable. It was for this reason that Schumann faced and solved the mechanical difficulties involved in making his adjustments without admitting air to the spectro-scope.

The original instrument was not large, the two fluorite lenses were of 120 mm. focal length for sodium light, and only 18 mm. aperture; the fluorite prism had an angle of 60°,

¹ "Ber. Akad. Wien.," 102, IIa, p. 625.

the distance between slit and the centre of the photographic plate was of the order of 32.0 cm. The angle between the optic axis of the camera lens and the photographic plate varied from 68° to 55°, depending on the part of the spectrum under investigation. For the other dimensions of the spectrometer the reader is referred to the original drawing in the *Bir. of the Vienna Acad.*, Vol. 102, 2a, 1893, p. 694. The plates in the *Smithsonian Contributions* do not quite agree with the original in scale.

The dispersion of the instrument was such that the aluminum lines λ 1989.9 and λ 1854.09 were separated by 5.8 mm. when they fell at the middle of the plate, the focal length in vacuum of the lenses was for this region, 106.7 mm. At the most refrangible end of the region the dispersion was, of course, much greater and the focal length correspondingly shorter.

The excellence of the slit contributed more than any other single factor to the wonderful definition obtained with the spectroscope. The slit widths employed when the finest results were secured varied from .0075 mm. to .0013 mm. ; the time of exposure varied from a few seconds to four minutes.

For the study of the hydrogen spectrum, a discharge tube of the "end on" type communicated directly with the spectroscope, being attached to the casing which protected the slit ; the discharge tube was then filled through the spectroscope with hydrogen to a pressure of about 2 or 3 mm. of mercury. When the emission of other gases was under consideration, the discharge tube was separated from the rest of the apparatus by a window of fluorite and was separately filled with the gas in question. Under these circumstances, the pressure in the spectroscope was usually about $\frac{1}{2}$ mm.

For examining the relation between the length of a column of gas and the absorption which it produced, Schumann designed a metal cell bounded by fluorite plates so perfectly constructed that the length of the gas layer could be varied continuously from 0 to 15 mm. In order to secure satisfactory operation, it was found necessary to keep the temperature constant, the device was accordingly surrounded

by a water-bath. For these absorption experiments, the "end on" tube filled with hydrogen and closed by a fluorite window was employed as source.

The firm of R. Feuss of Steglitz have constructed a spectrograph on nearly the same plan as the original Schumann instrument, but of about twice the linear dimensions. This apparatus was employed by Handke¹ in his study of the spark spectrum of metals. Very recently Wolff² has used a similar instrument constructed by Feuss with lenses of 15 cm. focal distance and 1.6 cm. aperture.

Trowbridge³ has described a vacuum prism spectrograph of an entirely different type, in which the lenses were replaced by mirrors. Up to the present time, however, this instrument has not been tested in the region of extremely short wavelengths.

While a prism spectroscope is admirably suited for general exploration in the Schumann region because of its compact form and the brilliancy of its spectrum, it is unfitted for wave-length determinations unless the dispersion curve for the prism is known. Several attempts were therefore made to devise a grating instrument with which wave-length measurements could be carried out. The first of these attempts was not crowned with much success. Morris Airey⁴ worked with a transmission grating on fluorite and with a concave grating. He measured a few lines in the spark spectrum of aluminum. The values are reprinted in Watts' Tables; they do not agree with the measurements of other observers. Wolff⁵ tried to use the fluorite transmission apparatus but abandoned it for the prism form. Kayser and Runge⁶ designed two reflection grating spectrographs to be used in vacuum, but they did not employ them beyond the region of λ 1850.

Beside the fundamental advantage of a concave grating over a prism system, the former is much more easily adjusted than the latter, for, by properly proportioning the apparatus,

¹ "Inaug. Dis.," Berlin, 1909.

² "Ann. d. Phys.," 42, p. 825, 1913.

³ "Zeitsch. f. Instrumentenkunde," 30, p. 334, 1910.

⁴ "Proc. Manchester Phil. Soc.," 49, p. 1, 1904.

⁵ Loc. cit.

⁶ "Ber. Berlin Akad.," III, p. 5, 1892.

the whole Schumann region may be obtained in good focus on one photographic plate at one time. On the other hand, the distribution of the light in the spectra of various orders usually makes the intensity of the light in any one grating spectrum inferior to that obtained with a prism. Finally, the great optical distance between slit and photographic plate necessitates very great freedom from leak in the grating spectroscope.

The first successful attempt at wave-length measurement in the Schumann region was carried out at Harvard University with a concave grating.¹ As the construction of this successful apparatus is probably not familiar to the general scientific reader, it seems worth while to give a rather detailed description of it.

THE GRATING SPECTROSCOPE.

The apparatus consists of two parts, the spectroscope itself and the vacuum receiver in which it is enclosed. The spectroscope is formed of a drawn brass tube 9.1 cm. in internal diameter, 96 cm. long, and 1.5 mm. thick, one end of which is provided with an arrangement for holding the grating while the other end carries the plate-holder and slits. The grating mounting consists of a square brass plate pivoted to turn about a vertical axis. The grating is held against this plate by springs, while screws through the back of the plate permit of the necessary adjustment about a horizontal axis. At the end not occupied by the grating a draw tube fits into the large tube. Upon the end of this draw tube are mounted the slits and plate-holder in a manner shown in Figs. 2, 3, 4, and 5, and which may be described as follows: A circular brass disc closes the end of the draw tube and is pivoted about a vertical axis, AA, Fig. 5. The motion of this disc is regulated by the screws, XX. Upon the disc are mounted the two slits, SS. The width of the slits is controlled by the usual screw adjustment. In order to be able to adjust the slits parallel to each other one of them is mounted in a tube which

¹"Astrophysical Jour.," 23, p. 181, 1906.

turns in the disc; the amount of this twist is regulated by the lever, L.

The plate-holder, C, is so constructed that several photographs may be taken without withdrawing it from the ap-

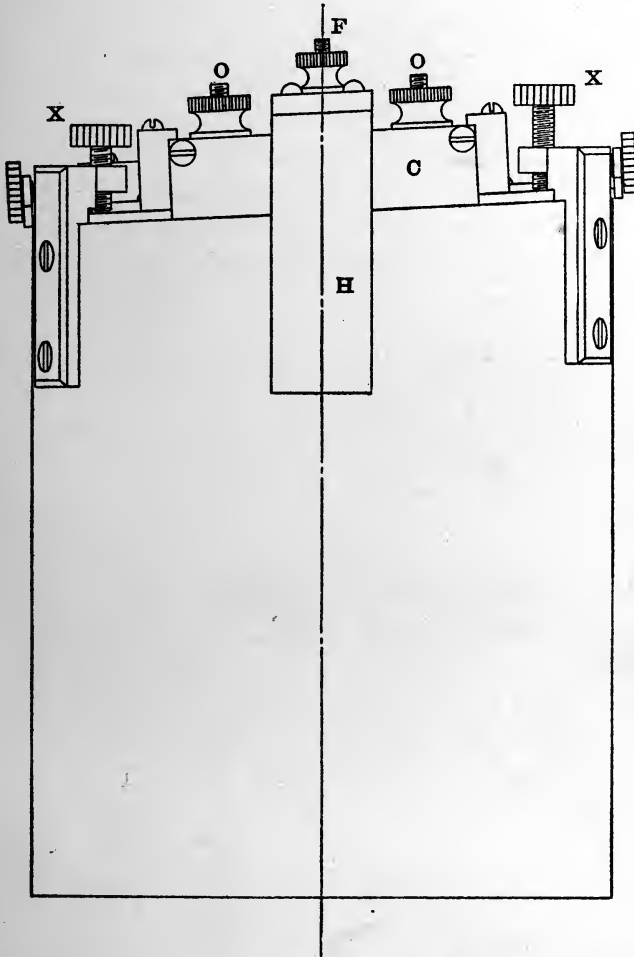

FIG. 2.

paratus. To this end the disc carries two ways, DD, in which the plate-holder slides. The position of the holder in the ways is controlled by the lever, E, pivoted about the point, F. One end of this lever carries the pin, G, while the other end is pro-

vided with an iron armature, H. The pin, G, engages one of the horizontal rods, I, and thus holds the plate-holder in position. To shift this position it is only necessary to swing the lever about F by means of a magnet exterior to the apparatus;

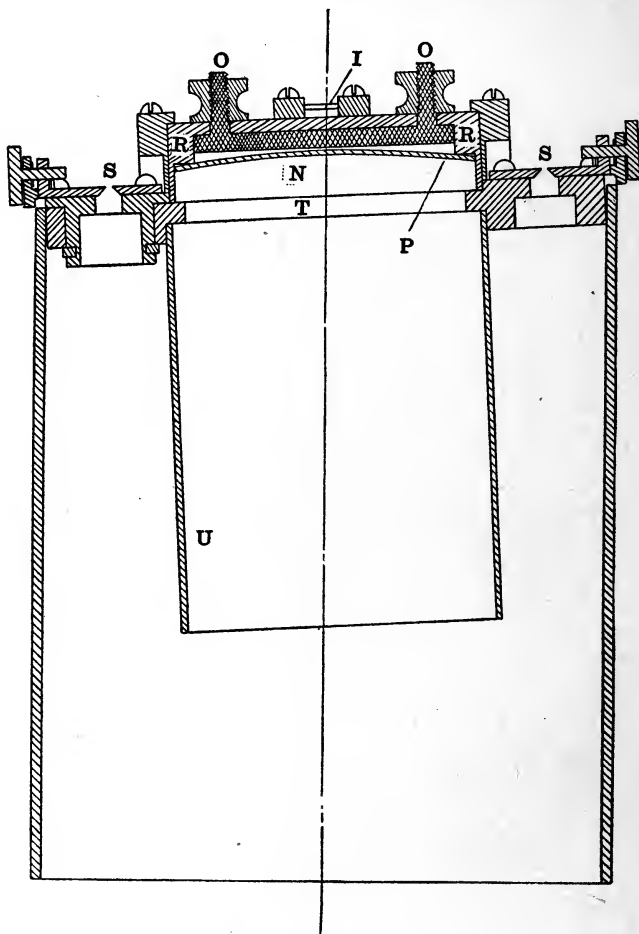

FIG. 3.

the pin, G, then slips past one of the rods, I, and the plate-holder falls by an amount corresponding to the distance between two rods. The plate-holder is designed to permit the plate to be bent to the arc of a circle of given curvature. To this end it is constructed in two parts, the outside case, C, and

the movable form, M. The form (shown withdrawn from the case, Fig. 4) carries two strips, NN, whose undersides are cut

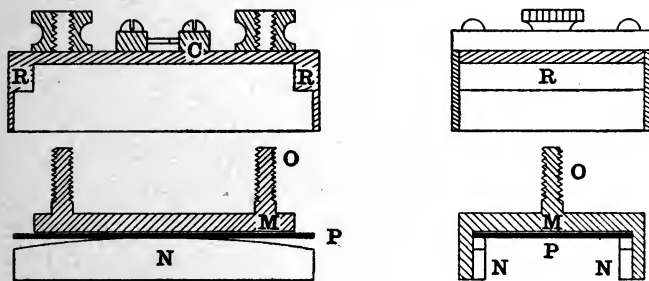

FIG. 4.

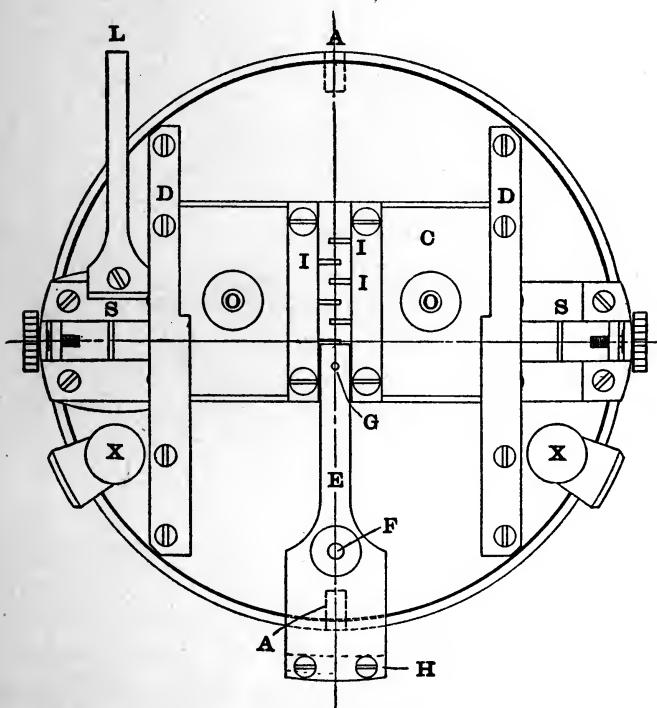

FIG. 5.

to the desired curvature, the ends of these strips project beyond the main body of the form. The plate, P, is slipped into the

form and is tangent, when unbent, to the curved strips at their middle point. The form is then drawn into the case by means of the screws, OO, the ends of the plate come up against the shoulders, RR, and as the screws are tightened the plate is bent to coincide with the strips, NN.

The apparatus is so constructed that the curve to which the plate is bent passes through the slits. Light has access to the plate through a slot, T, cut in the disc, which slot also serves as a diaphragm for the spectrum. A sleeve, U, shields the plate from scattered light; and to reduce the reflection from the walls of the tube a set of circular diaphragms is provided. The whole system, draw tube and large tube, is blackened inside. In the early work it was proposed to enclose the spectroscope as above described in a large glass tube, but owing to the difficulty of closing such a receiver airtight, and owing to the great liability of tubes of this size to break, the plan was abandoned. The receiver at present in use consists of a drawn brass tube 11.3 cm. in diameter, 110 cm. long, and 1.8 mm. thick. It is provided with two flanges, one at each end, cut from sheet brass and soldered to the tube. The flange at the end destined to be nearest the grating is closed by a circular brass plate, ground true, some 17 cm. in diameter. Plates of two kinds have been used to close the other end of the receiver. In the simpler form, a circular brass disc was only pierced by the two holes destined to admit light to the slits of the spectroscope. In the more complex form, Fig. 6, a hand hole is also provided through which the plate-holder may be introduced. This hole is 6.2 cm. in diameter and is closed airtight by a conical plug. In order to give this plug a sufficient bearing, a sleeve some 4.5 cm. high is attached to the face-plate. An inlet tube inserted about midway down the length of the receiver serves to exhaust the air; a wooden frame holds the apparatus horizontal. To facilitate the handling and development of the dry plates the end of the receiver is inserted in a small dark room. Into the receiver thus described the spectroscope is slipped, small hard rubber-legs hold it in a central position.

The concave grating with which the work has been done

was ruled in 1903 on the improved engine at Johns Hopkins University. The material is the usual speculum metal, the

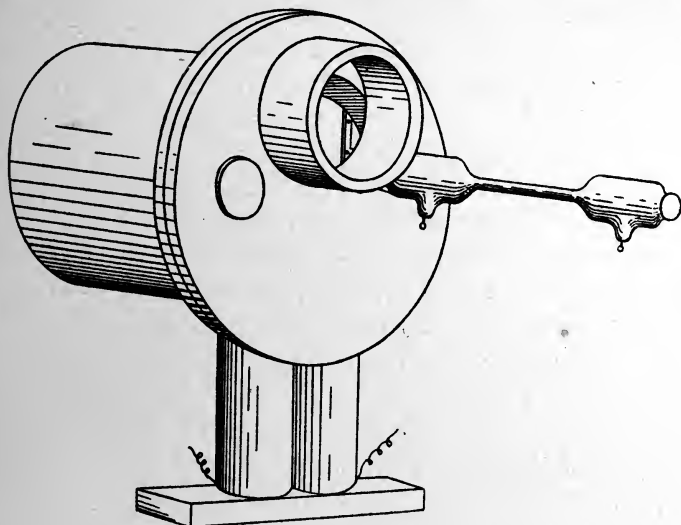

FIG. 6.

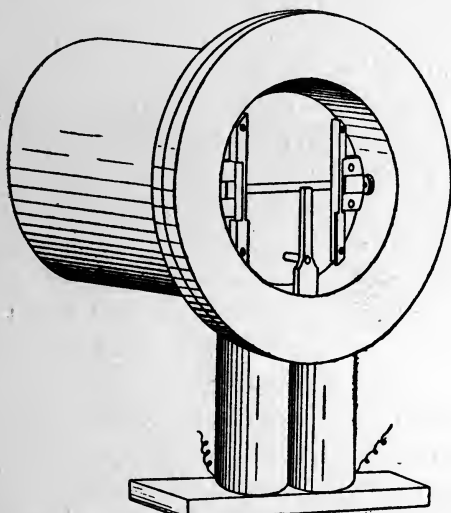

FIG. 7.

radius 97 cm.; there are 15,028 lines to the inch. The diamond point was selected with the object of throwing as much of the light as possible into one spectrum. To the

great success which attended this effort the results of the work are due, for the instrument possesses one first spectrum of extreme brilliancy.

As the experiment is carried on in an atmosphere of hydrogen the preparation of the gas is an important factor. Zinc and hydrochloric acid of the greatest commercial purity obtainable are used. The gas is passed over potassium hydrate and collected over distilled water. Before the gas is admitted to the spectroscope it is dried over calcium chloride and phosphorous pentoxide. The drying tubes are protected at each end by a stop-cock ; thus the gas does not flow through the system directly but stands over the material for some minutes before entering the spectroscope. The perfect dryness of the gas is necessary for the success of the work. All connexions between hydrogen apparatus, tubes, and spectroscope are of glass. The exhaustion is effected by a Trimount oil pump driven by an electric motor, the pressure is read by a McLeod gauge properly protected by drying tubes. Here again all connexions are of glass. All air admitted to the spectroscope is passed through a separated set of drying tubes. These precautions have been found necessary to prevent the appearance of absorption bands. The joint between the brass receiver and the system of glass tubing is made by a glass sleeve sealed with Khotinski cement, a preparation resembling a superior kind of sealing wax. Though this form of joint leaves something to be desired, nothing better has as yet been devised.

The use of a discharge tube separated from the receiver by a fluorite window necessitates a separate connexion with the pumping system, for the tube must be exhausted apart from the receiver and filled with the gas to be studied.

The form of the discharge tube depends upon the manner of making the experiment. If the tube is to communicate directly with the receiver, so that the whole apparatus is filled from the receiver with hydrogen, the usual form of capillary tube with ring electrodes is employed. The dimensions in a typical case were as follows : Length of capillary, 6.4 cm. ; internal diameter, 2.5 mm. ; diameter of electrodes, 1.6 cm. ; dis-

tance of mouth of tube to electrode, 4.5 cm. This last dimension is of special importance, since if it is made too small the discharge from the tube spreads into the receiver and produces fog, and if it is made too large intensity of illumination is sacrificed.

If the tube is to be separated from the receiver by a window and is to be separately exhausted, a special form is used. Here the end of the internal capillary is brought as near the fluorite window as may be without undue heating.

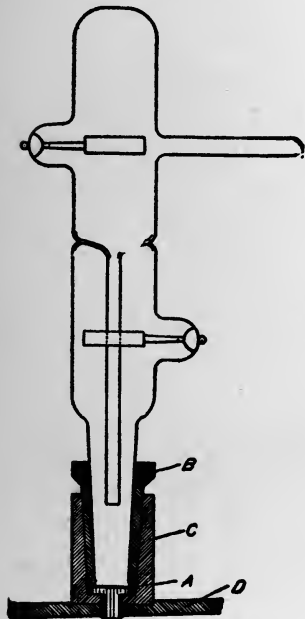

FIG. 8.

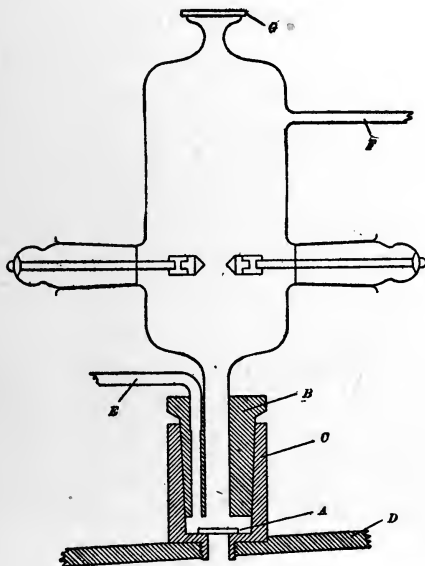

FIG. 9.

A device of this type not only brings the source of light near to the slit of the spectroscope but reduces the absorption in the tube itself to a minimum. The last advantage is a most important one in dealing with gases such as air which absorb strongly. The electrodes in both forms of tube were usually of aluminum, but iron, copper, and silver have also been tried.

The manner of attaching the discharge tube to the spectroscope receiver is shown in Fig. 8.

The tube, if it be of the internal capillary form, has a ground flange at its lower end; to this flange is attached a

fluorite window by means of Khotinski cement, care being taken that the cement is applied only to the outside edge of the flange in order that none of it may come in contact with the gas. This window is indicated in the figure at A. The tube thus closed is fastened in a brass cone, B, by means of Khotinski cement. This cone fits airtight into a cup, C, which in turn screws on to the face-plate of the spectroscope. Thus the gas under examination does not come in contact with the brass of the mounting. This is a considerable improvement over other arrangements. If extreme purity in the gas is not a requisite, it is convenient to attach the fluorite window directly to the bottom of the cup C, for with this arrangement the window can be readily cleaned by simply withdrawing the discharge tube. If the tube is to communicate directly with the spectroscope the window is dispensed with altogether.

When the spark spectra of metals were under investigation the discharge tube was replaced by a cylindrical glass vessel about 8 cm. long and 4 cm. in diameter furnished at one end with a window, and drawn out into a tube 1 cm. in diameter at the other. This tube fits into the brass cone, B, and is held in place by cement. The cone, in turn, fits airtight into the cup, C. The cup screws on to the face-plate of the vacuum spectroscope, D, and has attached to it a fluorite window, A. The point which distinguishes this arrangement from that employed with a discharge tube consists of a tube, E, which penetrates the side of the cone and through which a stream of hydrogen is directed into the spark chamber. This stream of gas, after striking the fluorite window, turns and is directed against the spark discharge and finally makes its way through sulphuric acid into the outer air by means of F. By a suitable arrangement of stop-cocks, the spark chamber may be exhausted through E. When it was found necessary to replace the stream of hydrogen by an atmosphere of helium, the gas was introduced through the tube, F, after the vessel had been thoroughly exhausted.

The metal under examination is held in suitable clamps and introduced into the chamber through two ground joints

as shown in the figure. The discharge is viewed through the window, G, during the course of the experiment.

ADJUSTMENT.

After the spectroscope is placed in the receiver the grating is turned until that part of the first spectrum to be investigated falls on the photographic plate. The arrangement of two slits serves a double purpose, as by it either the method of shifted spectra or the second spectrum comparison method may be used, without altering the position of the grating. For no matter which method is to be employed the grating is so placed that light from the right-hand slit gives the region of short wave-length in the first spectrum, while by illuminating the left-hand slit a shifted first spectrum is obtained superposed upon a shifted second spectrum. The dimensions of the apparatus are such that when the longest wave-length which falls on the plate from the right-hand slit lies in the region of 1900 Ångströms, the longest wave-length in the shifted first spectrum has a value of about 3100 Ångströms. Observation of lines in the shifted spectrum serves, therefore, as a simple test of the exact position of the grating. When this position has once been reached the grating end of the receiver is closed, a very little Travers' india-rubber grease being used in the joint, and the edge is painted with shellac. It next becomes necessary to prepare the other face-plate. If the shifted spectrum method is to be employed, this process consists in covering that hole which is to admit light to the left-hand slit with a quartz window and attaching the discharge tube over the right-hand opening. The face-plate with the tube attached is applied to the flange of the receiver, care being taken that the capillary of the tube is in line with the slit and with the centre of the grating. To facilitate this operation, discharge tubes are made double ended, that is, they have a quartz window by means of which it is possible to look through the capillary to the slit and thus assure correct alignment. Fig. 6 illustrates the appearance of the improved form of plate and discharge tube in position.

The fact that the end of the receiver is in a dark closet

permits the plate-holder to be placed in the ways of the spectroscope through the hand-hole without danger of fog. The hand-hole is next closed by the conical plug. The apparatus is now ready to exhaust. If no window is used between discharge tube and spectroscope, both parts of the apparatus are of course exhausted together and both are filled with hydrogen together. If a window separates the two, the tube must be exhausted separately and filled from the separate supply of the gas under examination. In either case the most laborious part of the adjustment lies still ahead, for the spectra from both slits must be in focus at the same time and the position of the plate-holder can only be determined by trial. It is therefore necessary to take a series of spectro-

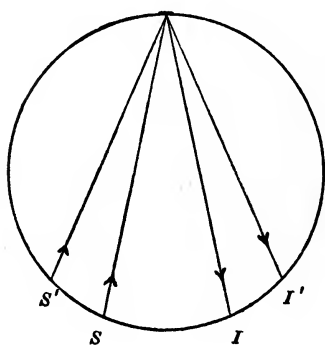

FIG. 10.

graphs, removing the face-plate after every trial in order to change the adjustment of the spectroscope, and replacing the plate on each occasion airtight, in order to exhaust and fill with hydrogen. As can be easily understood from the figure, that the conditions of adjustment should be fulfilled both slits must lie on the circle whose diameter is the grating's radius of curvature, and the plate must form a part of the arc of this circle. By construction, the curve to which the plate is bent passes through the slits. There are then two degrees of freedom of adjustment, the draw tube can be run in and out and the disc can be turned about the axis, AA; these two motions will suffice to bring the slits and plate into their correct theoretical positions.

Tedious as is the method of trial above described it has seemed better to adopt it rather than to complicate the apparatus by the introduction of devices to regulate the focus from outside the receiver. Such devices might allow the focus to be changed without admitting the air, but the problem of moving joints which must be maintained airtight is one which does not permit of easy solution. Once the spectroscope is in

adjustment the face-plate, if it is of the improved form. can remain permanently in place; the dimensions of the apparatus being such that the whole Schumann region to λ 1200 is in focus at one time and on one plate.

In practice the receiver is washed four or five times with hydrogen before a spectrogram is made. The powerful Trimount pump is capable of reducing the pressure to about $\cdot 08$ mm. in a half-hour. Dry hydrogen is then admitted in sufficient quantity to raise the pressure to about 10 cm. This "filling" is allowed to remain in the receiver for an hour or more, a procedure which appears to assist the removal of the films of air in the inside of the apparatus. The fillings of hydrogen which are subsequently introduced are allowed to remain but a few minutes.

When the discharge tube is separated from the body of the spectroscope, as was the case with all gases except hydrogen, it is obviously necessary to take such precautions as the best spectroscopic practice indicated in order to secure the purity of the gas. A long U tube dipped in liquid air and connected very near the discharge tube has proved one of the most useful of these precautions.

The width of slit used varied from $\cdot 09$ mm. in the case of the crude experiments to about $\cdot 025$ mm. in the case of the fine plates from which measurements have been made. Thus the slit width is considerably greater than that used by Schumann. The time of exposure for the hydrogen spectrum varied between five and thirty minutes according to the width of slit and the sensitiveness of the plate.

METHODS OF MEASUREMENTS.

In determining the wave-lengths of the lines in the hydrogen spectrum which have served as standards in the Schumann region two methods were used. The values of all the lines were first obtained by the two-slit method and these values were then checked by obtaining the stronger lines in the second spectrum and comparing their positions with known iron lines in the first spectrum. For this last purpose the first and second spectra obtained from the left-hand slit were employed.

The theory of the two-slit method is briefly as follows : If two slits, S and S' , be placed on that circle whose diameter is the grating's radius of curvature, the illumination of these slits by white light will give rise to the images, I and I' . To each of these images a set of spectra will correspond (see Fig. 10). For the present purpose it is sufficient to concentrate the attention on the two first spectra. It is evident that these two spectra will be shifted with respect to each other by an amount depending on the distance between the slits. If a photographic plate be placed between S and S' , and if the height of these slits be properly adjusted, one of these spectra will be superposed upon the other. At a given point, P , on the plate, the light brought to focus from S will be of a shorter wave-length than that from S' . If the sources of light be so selected that the wave-lengths in both spectra arriving at P have known values, then the shift of one spectrum with respect to the other may be determined by comparison of these values. If the apparatus is in adjustment both spectra are in focus upon the same circle, and the amount by which one spectrum is shifted over the other is a constant quantity ; that is to say, if the shift is determined by comparing known lines at one end of the plate, it must have the same value at the other end. It is upon this property that success in the use of method depends.

It next becomes of importance to inquire to what extent small errors of adjustment will influence the constancy of the shift. Here the nature of the method upon which the observer must rely in determining the perfection of this adjustment must be remembered. The only practical test consists in the sharpness of focus of the two spectra. It is the object then to manage matters so that both spectra shall be in perfect focus throughout the plate's length and at the same time. The vital question at once suggests itself: Is this test sufficiently delicate for the present purpose? If very accurate results are required the question must be answered in the negative. A little consideration makes it obvious that the relative position of the images, I and I' , and hence the shift, changes with the focus more rapidly than can usually be detected by the change

in sharpness of the lines. In other words, if the shift were given, the proper focus would be accurately determined, but if the sharpness of focus must be relied on, then the true shift can only be approximately inferred. Or again, for practical purposes, the apparent shift varies slightly more rapidly with variation in adjustment than does the sharpness of the spectral lines. The foregoing is, of course, somewhat dependent on the manner in which the adjustment is made. In the apparatus in question the slits and the photographic plate are rigidly fixed on the arc of the circle. This arc is capable of being thrust in or out, parallel to itself, along a line connecting the centre of the grating and the centre of the photographic plate; it is also capable of rotation about its middle point. By these two movements perfect adjustment can be attained, but the test of this adjustment is not absolutely adequate.

The practical application of the method is as follows: The spectrum of iron was selected for comparison work. The grating was so turned that known lines in the spectrum of aluminum fell upon one end of the plate when the right-hand or direct slit was illuminated by light from a spark between terminals of the metal. The shift of the principal spectrum with respect to the comparison spectrum was then determined by comparing the positions of these lines in aluminum with known lines in the spectrum of iron. In order to insure accuracy this shift determination was recorded on the same plate as the spectrum of hydrogen whose lines were to be measured. This was conveniently brought about by admitting the light from the aluminum spark directly through the discharge tube, for which purpose the tube was fitted with a window of quartz at the end not attached to the face-plate. Upon the spectrum to be measured was superposed the comparison spectrum of iron, and in this spectrum fiducial lines were selected. The relative value of these lines was then obtained by subtracting the shift from their real value, previously corrected to vacuum. These relative values were then used as points of departure to determine the wave-lengths of the unknown gas spectrum. In practice the shift was 1180 Ångström units so that the point in the iron spectrum falling

on say λ 1440 of the gas spectrum has a value of $1400 + 1180 = 2580$ Ångströms.

Owing to the dimensions of the plate only a region of about 760 tenth metres can be photographed at one time. Thus if the aluminum line λ 1935.9 falls upon one extreme of the plate, the other end corresponds to wave-length λ 1175. In order to investigate light of shorter wave-length than this value it is necessary to turn the grating, a process which necessitates a slight change in the adjustment of slits and plate.

To check the values obtained in the above manner lines of short wave-length were obtained in the second spectrum. For this purpose the left-hand slit was covered by a discharge tube without a window and the whole apparatus was filled with hydrogen exactly as usual. Owing to the feeble character of the second spectrum only the stronger lines between λ 1550 and λ 1200 could be photographed. Their position was determined by comparison with first spectrum iron lines, obtained from light which had passed directly through the discharge tube. The average difference between the values obtained by the two methods was 0.3 Ångström unit.

It was only in the study of the spectrum of hydrogen that plates bent to the arc of the focal circle were employed. In all subsequent work flat plates have been used.

APPARATUS FOR THE STUDY OF ABSORPTION.

When the absorption of gases was studied with the grating spectroscope just described a cylindrical chamber consisting of a vessel of glass .914 cm. thick and 2 cm. in diameter and closed by two windows of fluorite was attached by Khotinski cement to the inside of the face-plate of the vacuum receiver in such a manner that the light from the hydrogen discharge tube passed through it before striking the slit of the spectroscope. An outlet tube from this chamber passed airtight through a hole in the face-plate and was connected with a McLeod gauge, the pumping system, and the source of gas to be examined.

When the absorption of solids was to be studied the piece under trial was attached to the plate-holder at the end of an

arm in such a way that it projected to the right of the ways in which the holder moves. The length and shape of the arm was so adjusted that when the plate-holder was at its highest position the specimen was just above the right-hand slit, but when the holder had been allowed to fall the specimen fell with it, and came between the slit and the mouth of the discharge tube. The receiver was exhausted and filled with hydrogen in the usual way; rather a wide slit was used. A photograph was then taken with the plate-holder at its highest position, thus the light-path lay entirely in hydrogen. Next, by means of the magnetic device, the plate-holder was allowed to fall until the specimen came in front of the slit; the light from the tube now passed through it before reaching the slit. By comparing the two spectra, obtained one below the other on the same plate, the point in the spectrum at which the specimen cut off the light could be easily determined.

In testing the transparencies of a large number of substances for light of very short wave-length the method just described, though accurate, is tedious. A simpler arrangement has, therefore, been sometimes employed.¹ In it the photographic plate is replaced by a fluorescent screen coated with willemite, and the place of grating is taken by a concave mirror and fluorite prism. The construction may be understood by referring to Fig. 11. A brass casting, with a cavity of circular cross-section 8 cm. in diameter, contains the mirror and the prism; the top of the casting is closed airtight by a plug which screws into place. Into the sides of the casting, and nearly at right angles to each other, fit two brass tubes. One of these tubes, 21 cm. long, carries a flange at its far end closed airtight by a glass plate. The fluorescent screen, P, is placed a few centimetres from this plate and may be observed through it. The other tube carries the source of light. In order to secure the necessary brilliancy of illumination, no slit is used, the end of the capillary of a discharge tube serves itself as the source. The details of the arrangement are shown in Fig. 12. One electrode

¹ Lyman, "Astrophysical Jour.," 25, p. 45, 1907.

of the tube is formed by a platinum wire sealed in the usual manner, while the other electrode is the brass casting itself. Thus, when the apparatus is exhausted, the discharge passes from the platinum along the capillary to the sides of the casing, the end of the tube, some 0.9 mm. in diameter, furnishing a bright point of light. The bits of the substances whose transparencies are to be examined are fastened over the holes of the disc shown in the illustration. This disc can be rotated through a simple cog mechanism, by a key fitting airtight in the screw cover which closes the end of the casing tube. By this rotation the specimens are brought in turn before the end of the capillary and at a distance of about 6 mm. from it.

The mirror employed is of speculum, radius of curvature 25 cm., and the mounting is of a very simple form permitting movements about horizontal and vertical axes. The prism is of excellent white fluorite, by Zeiss, angle 60° ; it is mounted on a table fitted with levelling screws.

The exact dimensions are not essential to the success of the apparatus. Brass apparatus made from castings is almost sure to contain pin-holes, but the resulting leak may be reduced to a minimum by the use of thin shellac.

It is obvious that the optical arrangement is such that no great perfection of definition is to be expected. For the rough tests for which the instrument was constructed this, however, is not a serious drawback.

The operation of the instrument is as follows: The mirror and prism are so adjusted that the lines at the extreme ultra-violet end of the aluminum spectrum at λ 1854 fall on the end of the fluorescent screen. This arrangement is secured by the use of an aluminum spark in air and a slit temporarily placed in the casing tube at the point usually occupied by the end of the discharge capillary. A piece of fluorite of known transparency is then fastened over one of the holes in the movable disc, a second hole is left open, while the remainder are closed with pieces of the substances whose transparencies are to be tested. The temporary slit is now removed, and the face-plate with its discharge capillary and

revolving disc is screwed into place. The casing is next connected with a vacuum pump, and the pressure is reduced to a value of about 0.3 mm. of mercury. The apparatus is then washed three or four times with dry hydrogen, the pressure

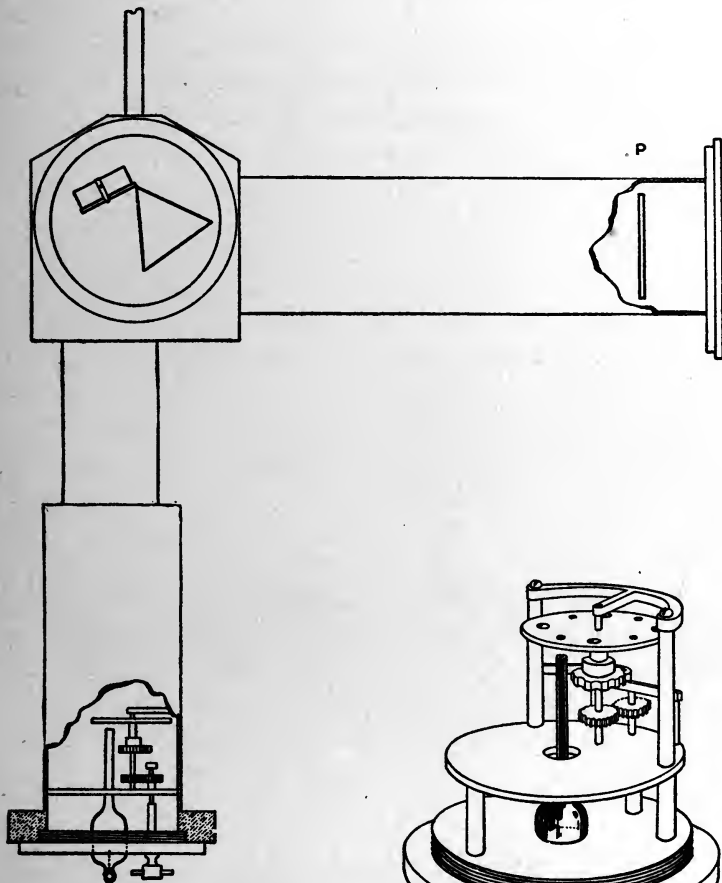

FIG. 11.

FIG. 12.

being finally reduced to 3 or 4 cm. The observer, seated in a darkened room, starts the current through the discharge capillary; with no absorbing medium in the light-path, the spectrum will then be seen to extend quite across the fluorescent plate—a distance of about 5 cm. Next, by turning

the key on the outside of the face-plate, the fluorite and other absorbing substances come in succession in front of the capillary, and their effect on the length and brilliancy of the spectrum is determined. In practice it was found convenient to use a piece of quartz for comparison in many cases, since most of the substances tested were far inferior in transparency to colourless fluorite. The results obtained by these eye observations were checked in all important cases by the photographic method. Comparison showed that the rough prism instrument could be trusted to detect the difference in transparency of two substances the length of whose spectra, when obtained photographically, differed by not more than fifteen Ångström units. When the object of the investigation is a purely practical one, the prism instrument fulfils the purpose for which it was intended. The arrangement of mirror, prism, and fluorescent screen may be employed for other purposes than that of measuring the absorption of solids: for, if the open capillary is replaced by an "end on" discharge tube closed by a fluorite window, sealed into the face-plate and separately exhausted, the apparatus serves to demonstrate the absorption of the air. If the discharge tube is excited and the casing is attached to a vacuum pump, the spectrum is seen to extend itself across the fluorescent screen as the pressure is diminished.

As will be shown presently, light of extremely short wave-length produces ozone energetically.¹ This action can be used not only as a means of detecting the Schumann rays but as a rough method of determining the relative transparencies of solid, liquid, and gaseous substances in the extreme ultra-violet. In such measurements, a discharge tube filled with hydrogen is used; the spectrum of this source contains no strong lines in the region between wave-lengths 3000 and 1675; therefore, as no appreciable amount of ozone is produced by light on the less refrangible side of this region, any effects observed must be due to light in the extreme ultra-violet. The tube is closed by a fluorite window, the material to be tested being placed on this window in a suitable con-

¹ Lyman, "Astrophysical Jour.," 27, p. 98, 1898.

tainer. The presence of ozone is recognized by the action of potassium-iodide-starch paper.

PREPARATION OF THE PHOTOGRAPHIC PLATES.

No matter what form of vacuum spectroscope is employed, no progress can be made in the region of extremely short wave-lengths unless dry plates specially adapted to the purpose are used. The investigations of the factors which control the sensitiveness of such plates and the evolution of the technique necessary in their manufacture, therefore, form a contribution of fundamental importance.

Soret¹ showed that gelatine absorbs strongly in the ultra-violet, and Schumann² extended these observations, using a series of quartz plates coated with gelatine in layers from $\cdot 13$ mm. to $\cdot 00004$ mm. thick. He observed that the silver bromide grains of his photographic plate varied between $\cdot 0012$ mm. and $\cdot 0017$ mm. in diameter, and his experiments indicated that a layer of gelatine of this order absorbed strongly near $\lambda 2265$ and increased rapidly in opacity with decreasing wave-length. On the other hand, experiments with silver bromide showed that this substance absorbed strongly in the ultra-violet. Taking this absorption as an indication of photo-chemical activity of the salt, he concluded that the lack of sensitiveness of the ordinary dry plate was not due to the lack of activity of the silver bromide but to the absorption of the gelatine contained in the emulsion. Accordingly,³ he first tried precipitating a layer of silver bromide directly on glass, and succeeded in producing a plate far more sensitive to the extreme ultra-violet than anything which he had previously made. Unfortunately, the silver salt did not adhere firmly, and the film after development was apt to float away during the process of fixing. This action could be lessened by making the film extremely thin, but it always constituted a serious fault in the method. He next tried coating the glass with gelatine and then allowing the silver

¹ "Arch. d. Sc. phy. et nat.," III., Vol. X, p. 453, 1883.

² "Ber. Wien. Akad.," 102, IIa, pp. 460 and 994; "Astrophysical Jour.," 3, pp. 220 and 387, 1896; 4, p. 144, 1896.

³ Loc. cit., p. 994.

bromide to settle on this surface. This procedure was a marked improvement, the gelatine playing a double rôle; not only did it serve as a means of binding the salt to the glass, but its presence increased the photo-chemical sensitiveness of the silver bromide. Moreover, plates of this kind gave a negative showing some contrast, a property which was entirely lacking in the negatives obtained with the pure salt.

A long series of experiments convinced Schumann that pure silver bromide gave better results than any combination of haloid salts, when precipitated in this way on gelatine. In addition to gelatine he tried agar-agar and gum-arabic as binding materials, but these experiments met with no success. Schumann also tried various methods of treating the finished plates. He discovered that bathing the plate in dilute ammonia increased the sensitiveness somewhat, but ultimately he found better means for securing the same end. Attempts at intensification with mercuric chloride were not successful.

He made the useful observation, however, that the size of the grain of the plate depended on the nature of the developer employed. Thus, a developer containing potassium bromide produced a coarse grain with a silver bromide plate; a developer free from potassium bromide gave a fine grain.

The process which Schumann¹ finally adopted for making his plates depended upon the same principle as the method last described, but differed in technique. In brief, it consists of forming an emulsion of silver bromide rather weak in gelatine; this is first sensitized by heating, it is then allowed to solidify and is washed, and dissolved in a great quantity of water. The diluted emulsion thus formed is poured on glass plates and allowed to settle. The superfluous fluid is then drained off and the plates dried.

The sensitiveness of the plates so prepared depends to a large degree on the temperature to which the emulsion is raised and the length of time during which it is exposed to this temperature: it is also somewhat dependent upon the temperature of the room in which the emulsion is allowed to settle. The perfection of the film as shown by its freedom from

¹ "Ann. d. Phys.," 5, p. 349, 1901.

fog and streaks depends upon the purity of the material employed, a small amount of organic matter exercising a very prejudicial effect. The nature of the developer and its temperature also play an important rôle.¹

Plates prepared in this way are extremely sensitive to the extreme ultra-violet; they also possess the rather remarkable characteristic of being quite insensitive to the light of longer wave-length than λ 3000. They are the only means at present employed for detecting light of the very shortest wave-length.

¹ See Appendix.

CHAPTER II.

ABSORPTION OF SOLIDS IN THE EXTREME ULTRA-VIOLET.

As has been already stated on page 13, quartz, rock-salt, and fluorite are the only substances which, occurring in clear masses of sufficient size, give promise of marked transparency in the ultra-violet. Of these three fluorite is greatly the superior. Schumann investigated the behaviour of crystalline quartz early in his work,¹ and ultimately became convinced that if very thin pieces were employed, they would be found transparent to the neighbourhood of λ 1500.² Subsequent observations have confirmed and extended these results, for it appears from work done with the grating spectroscope that a piece of crystalline quartz 2 mm. thick allows a considerable amount of light to pass down to the region of λ 1450. The absorption increases rapidly with the thickness, however, a piece 2 mm. thick cutting off the spectrum near λ 1600 and greatly weakening the region between this point and λ 2000. This behaviour is clearly shown in spectra 4, 5, and 6, Plate I, "Astrophysical Journal," 25, p. 45, 1907.

These results are in agreement with some rough measurements made by Handke.³

Fused quartz varies greatly in transparency. The best is somewhat less transparent than the crystalline material, while some specimens measured by Pflüger are quite opaque on the more refrangible side of λ 2000.

Rather rough measurements made with the prism-mirror vacuum spectroscope⁴ on fourteen specimens of crystalline quartz in pieces 1 and 2 mm. thick, some selected from right-

¹ "Ber. Wien. Akad.," 102, IIa, p. 455.

² "Smithsonian Contributions," 1413, p. 2.

³ "Inaug. Dis. Berlin," 1909.

⁴ "Astrophysical Jour.," 25, p. 45, 1907.

handed and some from left-handed pieces and some from specimens cut parallel and perpendicular to the optic axis, showed no difference in transparency which could be traced to the direction of rotation or to the position of the optic axis. If it were possible to apply the more refined method of Pflüger to specimens of this kind in the Schumann region, slight differences would probably be observed corresponding to those which exist in the ultra-violet.

On examining rock-salt with the grating spectroscope, it was found that it did not fulfil its promise of transparency in the Schumann region. The spectrum does not extend beyond λ 1750. The observations have been often repeated with various samples but always with the same result. Handke has confirmed this observation.

The factor which determined the extreme ultra-violet limit of the spectrum as obtained by Schumann was the absorption of the clear, colourless fluorite which formed the lenses and prisms of his apparatus. This fact was demonstrated with the vacuum grating spectroscope, for with this instrument it was possible to extend the spectrum considerably by removing all fluorite from the light-path. The phenomenon is illustrated in Plate II, "Astrophysical Journal," 23, p. 205. Without fluorite the limit of the spectrum in this plate lies near λ 1030; with fluorite it is cut off at λ 1230. Very recently the spectrum has been pushed to λ 905.

Though clear, colourless fluorite is rare and expensive, the coloured varieties are common enough, and sometimes may be obtained in clear masses of considerable size. Stokes¹ examined one coloured specimen that showed considerable transparency in the region of λ 1850. Specimens cut from purple, green, pink, and yellow fluorite of various shades have been tested both with the grating spectroscope and with the cruder prism-mirror apparatus. They were usually in the form of plates from 1 to 2 mm. thick. They show considerable range of transparency. A typical spectrum taken through a purple fluorite terminates abruptly at λ 1700. Of fifty-seven specimens, forty-two were less transparent than this purple sample,

¹ "Collected Works," IV, p. 221.

ten were nearly equal to quartz 1 mm. thick, and five were almost as good as colourless fluorite from Zeiss. From this test it appeared that the depth of colour was a good indication of the absorption; the most deeply coloured were the most opaque, while the five most transparent pieces were nearly, if not quite, colourless. There was one notable exception to this rule, however; four specimens from a light green crystal from Westmoreland, New Hampshire, U.S.A., were nearly as transparent as the plates from Zeiss. This crystal was free from flaws. There is some hope, therefore, that coloured fluorite may yet be found which will serve for prisms and lenses, and which will possess the requisite transparency for use in the region between λ 2000 and λ 1250.

It is well known that the colour may be removed from fluorite by heating, and, if the process is carefully carried on, no cracks are developed. This loss of colour, however, is accompanied by only the very slightest gain in transparency, if any. In ten cases out of twelve no difference could be noted at all either by the visual or by the photographic method.

A microscopic examination with a power of 200 diameters showed little difference in constitution between the transparent Westmoreland fluorite and the more opaque coloured varieties. In general, the specimens which showed the greater absorption seemed to contain the larger number of those fluid-filled cavities which have been so often observed. The colourless variety of fluorite from Zeiss was quite free from these microscopic enclosures.

The fluorescence excited by cathode rays was somewhat less brilliant in the colourless than in the coloured fluorite, but the differences were not of such a magnitude as to give an indication of the relative transparencies of the specimens. Recently, specimens of white fluorite from Zell in Baden have been examined. Some of them yield plates as transparent as the material obtained from Zeiss.

Though for the construction of prisms and lenses it is necessary that the material should be obtainable in large homogeneous masses, yet for the construction of the windows for vacuum tubes, relatively small pieces are often very useful.

With the hope of finding material which would serve this purpose, a considerable variety of substances have been examined. The results may be summarized as follows:—

*Topaz*¹.—Next to crystalline quartz, topaz from Ceylon shows the greatest transparency of all the substances examined. The result obtained from the photographic method shows that the spectrum is cut off near λ 1575. The specimen was 1.5 mm. thick; it is thus inferior to quartz. Topaz from Japan, Utah, and Siberia is much less transparent than this specimen from Ceylon. It is possible, however, that this difference may be considered rather as a peculiarity of the individual specimen than as a distinctive property connected with a region.

Gypsum.—This substance, when examined in bits 1 mm. thick bounded by cleavage surfaces, shows a spectrum which extends to the region between λ 1700 and λ 1650.

Celestite.—This substance, when examined in polished pieces 1 to 2 mm. thick, shows a transparency about equal to that of gypsum.

Barite.—In polished pieces 1 to 2 mm. thick the transparency is about equal to that of rock-salt.

Alum.—Pieces cut from crystals and 1 mm. thick show a spectrum ending near λ 1750, but of rather stronger intensity than that obtained with the rock-salt.

Colemanite.—Transparent to the neighbourhood of λ 1750.

Sugar.—Plates 1 mm. thick cut from crystals of rock candy are less transparent than colemanite.

The test pieces of all the substances just mentioned were clear and free from flaws. The surfaces were carefully polished.

In addition to the above, the following substances were tested and found perfectly opaque to light of shorter wave-lengths than 2000: borax, adularia, calcite, chrysoberyl, sanidin, arragonite, apophyllite, silver chloride (horn silver), kunzite, and diamond. Several of these are known to be opaque to light of longer wave-lengths than 2000. The tests were made in the hope of discovering some material which showed selective absorption to a marked degree.

¹ "Astrophysical Jour.," 25, p. 45, 1907.

In the case of diamond we have an example of a crystalline substance which is transparent to the visible part of the spectrum and to X-rays, yet which is apparently opaque to light of short wave-length.

Fritsch¹ and Zschimmer² have both called attention to the transparency of boric anhydride for ultra-violet light. Fritsch states that, as far as he could observe in a qualitative way with a quartz spectrograph, boric oxide (B_2O_3) exerted no absorption in the region of short wave-lengths. As a result of the observations with the vacuum grating spectroscope, it appears, however, that boric anhydride in thicknesses of 1 or 2 mm. is not transparent, for practical purposes, to light of shorter wave-length than λ 1700. This substance is, therefore, of the same order of transparency as purple fluorite. It is less transparent than quartz of the same thickness.

Water.—Quantitative measurements of the absorption of pure water on the edge of the Schumann region have been made by Kreuzler.³ He gives the following results: λ 1860, absorption 68.9 per cent; λ 1930, 24.5 per cent; λ 2000, 14.2 per cent. It was found that owing to the impurities communicated to the water by the vessel, concordant results could only be obtained when a hard glass trough was employed. The length used in the final experiments is not clearly stated; it was apparently of the order of 2 cm.; the vessel was, of course, closed with quartz windows.

Qualitative measurements have been made at Harvard⁴ with layers of distilled water in vessels of glass 0.5 mm. and 1 mm. thick closed with fluorite windows. The cells were introduced into the vacuum grating spectroscope in the same manner as when the transparency of solid substances was under investigation. Even with a prolonged exposure the .5 mm. water layer cut off the spectrum at λ 1729. Though the water used in these experiments was distilled, no particular precautions were taken.

Experiments in which the intensity of the Schumann light given off from a hydrogen tube was measured by the ozone

¹ "Physikal Zeitsch.," 8, p. 518, 1907.

³ "Ann. d. Phys.," 6, p. 420, 1901.

² *Ibid.*, 8, p. 611, 1907.

⁴ Lyman, "Nature," 8 July, 1910.

which it produced, indicated that in equal layers water was much more opaque than air, but that the absorption of the water increased less rapidly than that of the air as the thickness of the layer was increased.

Data on the transparency of all other liquids on the more refrangible side of λ 1850 are lacking. Such liquids as have been examined in the region of λ 2000 show great absorption.

DISPERSION OF FLUORITE.

The dispersion of fluorite has been calculated by a number of physicists.¹ Of the earlier of these results in the extreme ultra-violet, those of Martens² have proved to be, perhaps, most nearly in agreement with the facts. The data were obtained from a formula of the Kettler-Helmholtz type involving two absorption bands, the one in the red, the other at λ 9519. From a knowledge of the dimensions of Schumann's apparatus and by the use of these calculated indices, Martens estimated that the extreme point reached by Schumann had a wave-length of λ 1250; a result which subsequent measurements have shown to be very near the truth.

Handke,³ using a prism spectroscope of the Schumann type and employing the values of the wave-lengths of the hydrogen spectrum determined at Harvard University, measured the index of refraction for fluorite to wave-length λ 1311. In order to make the results of experiment agree with calculation, he found it necessary to introduce two absorption bands in the extreme ultra-violet in the dispersion formula, one at λ 1056, the other near λ 610. Handke's values may be found in the fourth edition of the Landolt-Börnstein Tables. The refractive indices of quartz⁴ and rock-salt have been determined only to λ 1854.

THE ABSORPTION OF GASES.

The air was the first gas whose absorption was investigated by Schumann. It will be well, therefore, to begin with a general account of its behaviour in the region of extremely

¹ Kayser, "Handbuch," IV, p. 477.

³ "Inaug. Dis.," Berlin, 1909.

² "Ann. d. Phy.," 6, p. 619, 1901.

⁴ Kayser, "Handbuch," IV, p. 484.

short wave-lengths before turning to the absorption of other gases.

Kreusler¹ found that a column of dry air 20.45 cm. long, free from carbon dioxide, absorbed 8.8 per cent of the light at wave-length λ 1860. At wave-length 1930 the absorption was so small that it could not be measured.

Schumann² examined the effect of change of thickness of the absorbing column; he employed the device which has already been described whereby the length of the absorption layer could be varied continuously. He used as source a discharge tube giving the spectrum of carbon dioxide. He found that the limit of the spectrum remained in the neighbourhood of wave-length 1780 while the path was reduced from 15 mm. to 8 mm. It was only when a length of 4 mm. was reached that the spectrum began to extend. From this point onwards the extension was much more rapid; with an air thickness of .5 mm. the last visible wave-length was in the neighbourhood of λ 1630. He carried his observations to air strata as thin as .05 mm. and showed that under these circumstances the spectrum stretched considerably beyond λ 1600. As the dispersion of fluorite had not been experimentally determined at this time, Schumann's wave-lengths were obtained by a process of extrapolation, a method which yielded only approximate results to the neighbourhood of λ 1600 and which completely broke down on the more refrangible side of this region. However, measurements on the absorption of air carried on at Harvard University³ by a method in which the limiting wave-lengths could be accurately determined, have served to confirm Schumann's observations to a marked degree.

It is important to note in this connexion how short must be the stratum of air in order that the region in the neighbourhood of λ 1600 may be transmitted. Before considering the behaviour of the air at the more refrangible limit of the Schumann region it will be most convenient to take up the absorption of some of its constituents.

¹ "Ann. d. Phy.," 6, p. 418, 1901.

² "Smithsonian Contributions," 1413, p. 29.

³ Lyman, "Astrophysical Jour.," 27, p. 89, 1908

Nitrogen.—Kreusler¹ found that nitrogen absorbed 2·2 per cent at wave-length 1860; the presence of small quantities of nitrous oxide (NO) increased the value very considerably. Schumann² states that “nitrogen proved itself very transparent, even beyond λ 1620, yet it absorbed particular wave-lengths very energetically.” Experiments with the grating vacuum spectroscope³ and a vessel 9·14 mm. long (see p. 48) showed that at atmospheric pressure nitrogen produces a very slight absorption extending continuously from λ 1800 or thereabouts to λ 1250. The strength of this absorption increases regularly with decrease in wave-length, but even at the most refrangible end of the spectrum it is very small indeed. The energetic, selective action mentioned by Schumann was not observed.

Oxygen.—This gas is the dominating factor in determining the transparency of the air. Kreisler⁴ ascribes an absorption of 32·5 per cent at λ 1860, 6·2 per cent at λ 1930, and a negligible absorption at λ 2000; the column was as usual 20·45 cm. long. Schumann makes the following statement: “Oxygen absorbs the rays in the neighbourhood of λ 1850 in a series of clearly resolved groups of lines fourteen in number. These groups, which are of band-like form, constantly approach nearer one another with the deviation and are shaded off toward the red. Complete absorption is found with the most refrangible of them. It is this which makes the air opaque for all rays beyond λ 1850.”

The work which has been done with the grating in vacuum has thrown much valuable light on the absorption of oxygen but has failed to prove the existence of these groups of lines near λ 1850 conclusively. This failure is probably due to the difficulty which was experienced in obtaining a continuous spectrum from a discharge tube in the neighbourhood of λ 1850, and to the fact that, though the slit employed was a good one, yet it fell far short of the perfection of the slit employed by Schumann.

These absorption lines are of particular interest in con-

¹ “Ann. d. Phys.,” 6, p. 418, 1901.

² *Ibid.*

³ *Ibid.*

⁴ *Ibid.*

nexion with the lines or bands observed by Steubing.¹ This investigator, using a mercury arc in quartz as a source and a quartz prism spectroscopie in air, designed to give a great deal of light in the ultra-violet, obtained three groups of bands extending from λ 1919 to λ 1831. He attributes the phenomenon to the fluorescence of the layer of oxygen between the source and the slit of the spectroscopie. These same bands have been observed with the vacuum grating spectroscopie at Harvard when a mercury arc was employed as source.² Unfortunately, the construction of the grating apparatus did not permit the observer to decide definitely whether these bands were really due to the fluorescence of oxygen in front of the slit or to the absorption of the oxygen within the apparatus. Very recently, Messrs. L. & E. Bloch³ have studied the phenomenon. They conclude that the bands are due to the absorption of oxygen, not to its fluorescence.

All the measurements on the great oxygen band carried out at Harvard were made with an absorption chamber of constant thickness (.9 cm.), the amount of absorption being varied by changing the pressure within this chamber. The discovery of the extreme ultra-violet limit of the band was the most striking product of these experiments.⁴ A discharge tube filled with a mixture of carbon dioxide and hydrogen served as source. A series of exposures was then made on the same plate with different pressures in the absorption chambers. Thus the uppermost spectrum was secured when the pressure in the chamber was a few hundredths of a millimetre, the succeeding spectra with pressures of .02, .05, .07, .1, .25, 0.5 and one atmosphere respectively. The lowest spectrum was taken under the same conditions as the uppermost. The character of the band is unmistakable. With a pressure of .1 atmosphere, the more refrangible limit is not visible in the reproduction, though it can be just made out in the plate itself, but as the pressure in the absorption chamber is decreased this limit comes into view. Most unfortunately,

¹ "Ann. d. Phys.," 33, p. 572, 1910.

² Lyman, "Astrophysical Jour.," 38, p. 284, 1913.

³ Comptes Rendus, 158, p. 1161, 1914.

⁴ Compare Plate VII, Lyman, "Astrophysical Jour.," 27, p. 87, 1908.

a more careful study of the more refrangible region is much interfered with by the absorption of the fluorite windows, which first begins to be noticeable near λ 1300. There does seem to be, however, some indication that another absorption band exists, lying in the region shut out by the opacity of the fluorite. Nothing definite can be said on the subject, however.

The unsymmetrical character of the band is very striking, for, with increase in pressure, the absorption spreads much more rapidly toward the less refrangible side than in the other direction. Unsymmetrical effects of this kind are not uncommon. Such a band exists in chlorine, as was shown by Miss Ladd,¹ and more recently Wood² has called attention to the same phenomenon in an absorption band in mercury.

From theoretical considerations Planck predicted that for very strong absorption the less refrangible side of a band should widen more rapidly than its more refrangible limit with increase in pressure. Unfortunately, it is difficult to check the theory by experiment, for, as Kayser has pointed out, it is almost impossible to tell whether the movements of the edges of the band are real or apparent. However, it is interesting to note in connexion with the behaviour of this band in oxygen, that Larmor³ has attributed the phenomenon of unsymmetrical widening to a variation in number of loose molecular aggregates within the gas with change in pressure. The formation of ozone by light of extremely short wave-length (see p. 66) and the volume ionization observed by Lenard⁴ and by Palmer⁵ in the Schumann region might easily produce the molecular aggregates in oxygen required by the theory, but how the number of these aggregates changes with the pressure is an open question. Aside from speculation, it must be observed that of all gases examined in the Schumann region, oxygen is by far the most opaque. It is natural, therefore, to connect the mechanism of this great absorption with the photo-electric and photo-chemical phenomena just

¹ "Astrophysical Jour.," 14, p. 114, 1901.

² *Ibid.*, 26, p. 41, 1907.

³ *Ibid.*, 26, p. 120, 1907. ⁴ "Heidelberg Akad. d. Wiss. Abhand.," 28, 1910.

⁵ "Physical Rev.," 32, p. 1, 1911.

mentioned which are known to be extremely active in oxygen.

Ozone.—The formation of ozone just referred to has been studied by a number of observers in the ultra-violet, but as observations on the action of Schumann light are not common, a description of some experiments on the subject may be of interest here.¹

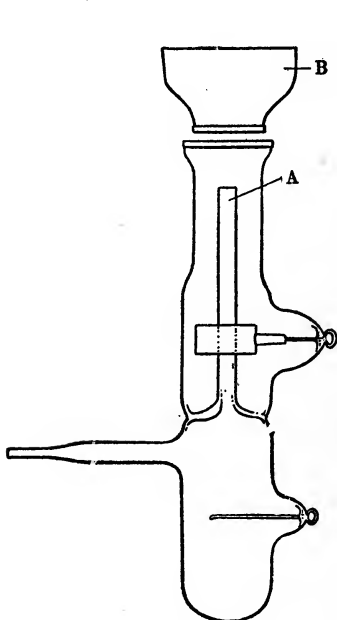

FIG. 13.

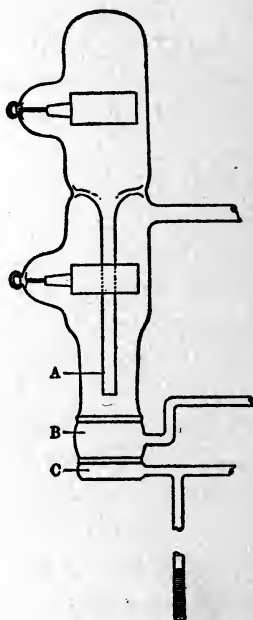

FIG. 14.

A discharge tube of the internal capillary type, Fig. 13, was filled with hydrogen to about 1 mm. pressure and closed by a fluorite window. The tube was excited by a transformer; the current in the secondary was of the order of 10 milliamperes. Under these conditions the gas showed the many-line spectrum of hydrogen. The following experiments were then tried:—

1. Half of the fluorite window was protected by a piece of microscope cover glass and over it was laid a bit of paper

¹ Lyman, "Astrophysical Jour.," 27, p. 87, 1908.

moistened with starch paste containing potassium iodide; in fifteen seconds the paper turned strongly blue where it was not protected by the glass, the protected portion remaining perfectly unaltered.

2. A piece of quartz 2 mm. thick was next placed on the fluorite window so as completely to cover it; the test paper was placed on the quartz. In fifteen seconds there was a noticeable discoloration of the paper, but the effect was not nearly so well marked as in case 1.

3. A shallow vessel, B, with a fluorite bottom was next placed directly upon the discharge tube so that the two fluorite plates were in contact. The test papers placed within this vessel upon the fluorite bottom showed in fifteen seconds a discoloration only slightly less than that observed in case 1.

4. The vessel, B, was now raised $\frac{1}{2}$ mm. above the window of the tube; thus the light was forced to penetrate a column of air $\frac{1}{2}$ mm. thick in addition to the fluorite plates; the discoloration of the paper in fifteen seconds was now very slight.

5. If the vessel was removed to a distance of 1 mm. no discoloration could be observed. It is evident that the agency which produced the discoloration is weakened by quartz and is, so far as these experiments show, entirely cut off by 1 mm. of air. There can be but little doubt that the agency is light of a shorter wave-length than λ 1850.

A more elaborate experiment was next undertaken. A discharge tube had cemented upon its fluorite window a chamber, B, Fig. 14, 0.7 cm. thick; this chamber in turn was closed by a fluorite window which carried a second shallow vessel, C, 0.1 cm. thick. This last vessel was connected to a manometer column which dipped in strong sulphuric acid. The function of the chamber, B, was to serve as a screen of variable transparency, and to this end it was connected to a mercury pump and McLeod gauge. The discharge tube was filled with hydrogen at about 1 mm. pressure. The vessel, C, was filled with oxygen at atmospheric pressure. No change in the manometer column was observed when the discharge tube was excited. It was only when the pressure in B had been

reduced to about 1 cm. that the acid in the manometer column began to rise, but this rise continued to increase as the pressure in B was reduced step by step. Care was taken to correct as far as possible for heat effects.

The results with this more complex apparatus serve to corroborate the results of the simpler experiment. There seems to be no doubt that light of wave-lengths shorter than λ 1850 acts to produce chemical action energetically, and that this action increases considerably in strength with decrease in wave-length in the region more refrangible than λ 1850. It must be remarked, however, that the starch-paper test cannot distinguish any more than the manometer between the production of ozone and hydrogen peroxide. The gas formed may be either the one or the other.

As to the absorption of ozone in the extreme ultra-violet, Schumann remarks,¹ speaking of oxygen, "The pressure of a moderate amount of ozone did not alter the absorption at all." Experiments with the grating spectroscope confirm this statement.²

Carbon Dioxide.—Kreusler³ attributes 13.6 per cent absorption to this gas at λ 1860. Schumann⁴ states that the absorption spectrum is similar to that of oxygen with an indication of a "rhythmical series in the shape of inverted groups of lines, but the end of this series is considerably more refrangible than that of oxygen. Accordingly, total absorption begins at a shorter wave-length." The observations made with the vacuum grating spectroscope are in very fair agreement with the statement made by Schumann, except that the rhythmical series were not observed near λ 1850. There were also some indications that maxima and minima of absorption do occur considerably on the more refrangible side of this position.

Carbon Monoxide.—According to Schumann,⁵ this gas absorbs the most refrangible rays somewhat less than carbon dioxide and gives, like oxygen, a series of rhythmical, inverted groups of lines. The clearness and sharpness of these lines

¹ "Smithsonian Contributions," 1413, p. 16.

² Lyman, loc. cit. ³ *Ibid.*

⁴ "Smithsonian Contributions," 1413, p. 16.

⁵ *Ibid.*

are less than with oxygen but far more perfect than with carbon dioxide.

On the other hand, results obtained with a grating show that the absorption is very characteristic and quite unlike that of oxygen, at least in the more refrangible part of the Schumann region.¹ There seems to be very little action from λ 1850 to λ 1600, but from λ 1650 to λ 1250 eight separate bands exist. The maxima occur near λ 1548, 1512, 1482, 1450, 1423, 1395, 1370, 1345. For any given pressure the bands decrease in width with decrease in wave-length. As the pressure is reduced, each band contracts, but even at a value of 0.1 of an atmosphere, all the bands are still distinguishable. They do not correspond to any lines or groups of lines in the emission spectrum of the gas. At least two of the bands seem to coincide with those observed in carbon dioxide. The limit of the spectrum, as shown in the illustration, is not due to absorption but to the character of the source of light.

As in the case of oxygen, the lack of a continuous spectrum in the source near λ 1850 probably accounts for the failure to detect the rhythmical groups of lines with the grating. Schumann confined his attention in almost all his absorption work to the region on the less refrangible side of λ 1600; this may explain the fact that he did not observe the characteristic bands just mentioned.

The absorption of carbon monoxide is very different from that of any other gas which has been investigated in the Schumann region. All the experiments with the grating were made with a single gas thickness of .91 cm. Longer gas paths should yield interesting results.

Helium.—This substance has been investigated only with the grating vacuum spectroscope.² In thicknesses of .91 cm. at atmospheric pressure, the gas shows no observable absorption in any part of the spectrum between λ 1900 and λ 1250. Experiments with a gas path of 6.5 cm. at $\frac{1}{4}$ of an atmosphere show that helium is quite as transparent as hydrogen under the same conditions.

¹ Compare Plate VII, Lyman, "Astrophysical Jour.," 27, p. 87, 1908.

² Lyman, loc. cit.

Argon.—This substance also has been tested only with the apparatus at Harvard. It shows no observable absorption between λ 1900 and λ 1250 in a column of .91 cm. long at atmospheric pressure.

Hydrogen.—Schumann¹ recognized that the transparency of hydrogen was uncommonly great. Upon this observation is based the procedure of washing vacuum spectroscopic apparatus with this gas. He calls attention to the fact, however, that it is extremely difficult to obtain information on the behaviour of thick strata of the gas because of the impurities communicated to it by the walls of the containing vessel employed. "These impurities affect the transparency of the hydrogen more proportionally than they would that of other gases, precisely because its transparency is so extraordinarily great."²

The results obtained with the vacuum grating spectroscope were in good agreement with these facts. When the gas was used in the .91 cm. absorption chamber at atmospheric pressure, it exercised no observable absorption.

An attempt was made to study its behaviour in long columns by introducing it into the spectroscope itself; in this case the path was about 200 cm. Here the gas was prepared from zinc of great purity and hydrochloric acid and was carefully dried by phosphorous pentoxide. Spectra taken through this gas at pressures of 1 to 5 cm. show an absorption band near λ 1700, which, as it decreased with successive changes in the gas filling, evidently was due to some impurity. This contamination of the gas probably arose from the brass of which the spectroscope is made, since all connecting tubes are of glass. A weak spot in the spectrum between λ 1300 and λ 1330 was observed with the lowest pressures in the receiver and was always present. It is impossible to say whether this is a true absorption band or if it is a characteristic of the emission spectrum of the source of light itself.

At pressures near one atmosphere the absorption was considerable, the end of the spectrum being in the neighbourhood

¹ "Ann. d. Phy.," 4, p. 642, 1901.

² "Smithsonian Contributions," 1413.

of λ 1600. Here again it is impossible to say whether this action is a property of hydrogen, or whether it is due to the presence of some impurity. A small trace of oxygen, for example, would account for the result. To make the experiment conclusive it would be necessary to work with a spectroscope which could be made chemically clean. This condition would be very difficult to fulfil. The longest gas path which has been examined under conditions which reduced the chances of contamination to a minimum was 6.5 cm. Here¹ the light from a spark contained in a glass vessel passed through hydrogen at atmospheric pressure. A number of spark spectra, extending nearly to the limit set by the transparency of fluorite, were obtained in this way. The experiment illustrates the great transparency of hydrogen.

Water Vapour.—Data on this substance in the extreme ultra-violet are lacking. Schumann did not succeed in obtaining any information. Experiments with the grating apparatus indicated a maximum of absorption between λ 1700 and λ 1600, with some promise of transparency on both sides of this region, but the results are rather doubtful. The formation of opaque films of water on the windows of the absorption cell is the factor which causes the uncertainty.

Kreusler² has shown that both nitric and nitrous oxides possess strong absorption in the ultra-violet. His measurements on the former substance give 88.4 per cent at λ 2000.

In conclusion, it is of interest to return to the absorption of the air. It appears that the absorption of carefully dried air can be described as due to the absorption of the oxygen and nitrogen which it contains. As might be expected, it is more transparent than oxygen, for, while with oxygen at atmospheric pressure and a path of 0.91 cm., the last visible wave-length is near λ 1760, for air under similar circumstances it is near λ 1710. Moreover, in air as in oxygen the absorption is in the form of a band. There is one difference to be observed, however, between the action of the gas mixture and that of the element, for with air the more refrangible end

¹ Lyman, "Astrophysical Jour.," 35, p. 344, 1912.

² Loc. cit.

of the band is rather indistinct, while with oxygen at a corresponding pressure it is extremely sharp. This effect is probably due to the presence of nitrogen, whose absorption, though very slight, is yet enough in the region of shortest wave-lengths to account for the result. It seems improbable that such traces of ozone, carbon monoxide, and carbon dioxide as are ordinarily to be found in the atmosphere can have any marked effect upon its absorption for the part of the spectrum under consideration. Moreover, from experiments on dry and moist air, the effects of such quantities of water vapour as occur in the air of a laboratory seem to be nearly negligible. It must be remembered, however, that in treating the absorption of the atmosphere for light less refrangible than λ 1900, these statements may not be true.

Finally, it is of considerable interest to inquire what inference may be drawn from the available data as to the transparency of the air for light of even shorter wave-length than that which has been recorded up to this time by spectrographic investigation.

Unfortunately, nothing very definite can be said on the subject. The fact that the ultra-violet limit of the absorption band in oxygen appears to spread in both directions with decrease in pressure points to the existence of a second region of absorption beyond the point at which fluorite becomes opaque. Moreover, as far as the data now at hand are concerned the absorption of nitrogen seems to increase rather regularly with decrease in wave-length. These facts taken together would indicate that no great improvement in the transparency of the air for light more refrangible than λ 1250 is to be expected. On the other hand, since the limits of one oxygen band have been discovered, it seems not improbable that if a second band exists, it too will have its end; moreover, it is perhaps legitimate to surmise that the absorption of nitrogen is in the form of a band, and that for very short wave-lengths this gas also may regain its transparency.

The absorption of the air is one of the important factors which determine the present limit of the spectrum in the extreme ultra-violet. A consideration of the part played by

the other agents which determine this limit will be found on p. 106.

Before leaving this subject it is well to remind the reader that data on the dispersion of gases lead theoretically to a knowledge of the position of their absorption bands. Unless the dispersion curve is determined for a long range of the spectrum, however, the position of the band is not trustworthy. The calculated position for the oxygen absorption band resting on the Cuthbertson's¹ data is a good illustration of this fact.²

¹ "Proc. Roy. Soc. A.," 83, p. 151, 1910.

² Dember, "Verh. Deutsch. Phys. Gesell.," 15, p. 564, 1913.

CHAPTER III.

EMISSION SPECTRA OF GASES.

HYDROGEN surpasses all other gases in the wealth and strength of lines in the Schumann region; these lines extend from λ 1675 to the very end of the extreme ultra-violet near λ 900. The general appearance of the spectrum was first investigated by Schumann to the point where fluorite absorbs strongly. Later, the spectrum was extended to its present limit with the vacuum grating spectroscope at Harvard and the wave-length of a great number of the lines was determined for the first time. These wave-length measurements form the only standards at present available in the extreme ultra-violet. They are given in Table I of the Appendix.¹

A comparison of the original prism spectrograms with the normal spectrum from the grating has been made; it not only proved the identity of the two spectra but has served to supply the beautiful plates of Schumann with a scale of wave-lengths.² This comparison was carried out in the following manner: the twelve plates of Schumann reproduced in the Smithsonian Memoirs were cut out and put together. The resulting spectrum, some 127 cm. long, was placed on a movable stand and the grating spectrum was projected upon it by means of a lens. By changing the magnification so as to keep step with the dispersion, the strong lines on the one spectrum were identified with those in the other from λ 1674 to λ 1269 without the least difficulty. From the values thus obtained interpolation curves were drawn for each of Schumann's twelve plates separately, and by means of these curves a scale of Ångström units was attached to each of the twelve illustrations. Except for a short range of some fifty or sixty

¹ See Frontispiece, No. 3.

² Lyman, "Astrophysical Jour.," 23, p. 204, 1906, Plates XII, XIII, XIV; "Memoirs Am. Academy," XIII, No. III, Plates III, IV, V.

Ångströms at the less refrangible end of the spectrum, the values read on the scale differ from those in the table by not more than $\frac{1}{3}$ of a unit.

Of the 285 lines given in the tables all but three or four are found in Schumann's plates. There are, however, a great number of fainter lines in the prismatic spectrum not visible in the plates obtained with the grating. Moreover, owing to the fineness of the slit, and the great dispersion used by Schumann, some of the single lines of the table are seen, by comparison with the prismatic spectrum, to consist of doublets or triplets.

The excellent agreement between these two spectra obtained under such different conditions makes the existence of any chance impurity very improbable.

The extreme limit in Schumann's map has the value λ 1266.9. That author has stated that he obtained some lines too faint to reproduce; from the angles given¹ it is difficult to calculate their exact wave-length, but it seems improbable that they should have a value much below λ 1230, since even thin plates of the best fluorite become opaque at this point. In this connexion it will be remembered that the calculation of Martins from the Kettler-Helmholtz formula for fluorite was not far from this.

Hydrogen possesses two distinct spectra in the visible and ultra-violet; of these, the primary spectrum consists of relatively few lines; it is enhanced when a disruptive discharge is used. The secondary spectrum, on the other hand, is made up of a vast number of lines and is observed to best advantage when a continuous current is employed. The position of the lines of the common primary spectrum may be very exactly represented by the formula due to Balmer, the secondary spectrum is far more complex and has defied analysis up to the present time. —

The hydrogen spectrum in the Schumann region, now under discussion, resembles the ordinary secondary spectrum in its complexity, but it is separated from it by a gap extending from λ 2483 to λ 1675; thus it appears to enjoy a separate existence. However, as the gap is filled by a continuous

¹ "Smithsonian Contributions," 1413, p. 24.

background apparently produced by hydrogen itself, the separation may be more apparent than real.

Attempts have been made to find a primary hydrogen spectrum in the extreme ultra-violet. To this end Schumann introduced a spark gap in series with the discharge tube and a capacity in parallel with it; the strong disruptive discharge which resulted yielded the primary spectrum in the visible, but in the region between λ 2000 and λ 1250 no new lines made their appearance which could be ascribed to hydrogen. The effect of capacity was simply to weaken and blur the secondary spectrum. Later,¹ during an investigation of spark spectra, Schumann discovered some lines common to all metals he investigated. He attributed these to the hydrogen in which the spark was produced. He believed these lines differed in character from members of the many-line spectrum which has just been discussed. Unfortunately, he did not give the position of the new lines.

A long series of experiments with the grating spectro-scope² confirmed the observation that the introduction of capacity weakens the spectrum. Certain lines were found with the disruptive discharge which were absent under the normal conditions, but these lines were generally ascribed to impurities from the electrodes or from the walls of the tube. The behaviour of a line near λ 1650, however, with changing conditions of the experiments could not be readily reconciled with the explanation, but, on the other hand, it could not be confidently asserted that this line formed a member of a primary spectrum of hydrogen in the Schumann region. Experiments with sparks in an atmosphere of hydrogen absolutely failed to confirm the observations of Schumann. Such few lines as were common to the many spectra obtained could be directly traced to common metallic impurities.

The absence of a primary spectrum in the region limited by the transparency of fluorite may be predicted in a general way from theoretical grounds. Thus, lines which constitute the primary spectra of hydrogen in the infra-red, the visible and

¹ Schumann, "Astrophysical Jour.," *II*, p. 312, 1900.

² Lyman, *ibid.*, 33, p. 98, 1911.

the ordinary ultra-violet, may be very approximately represented by the following formulæ:—¹

I. First principal series	$n = C \left\{ \frac{1}{1 \cdot 5^2} - \frac{1}{(m+1)^2} \right\}$	$m = 1, 2, 3.$	}	7686	H
II. Second „ „	$n = C \left\{ \frac{1}{1 \cdot 5^2} - \frac{1}{(m+5)^2} \right\}$	$m = 2, 3, 4.$			
III. Diffuse series	$n = C \left\{ \frac{1}{2^2} - \frac{1}{(m+1)^2} \right\}$	$m = 2, 3, 4.$			Balmer OK
IV. Sharp „	$n = C \left\{ \frac{1}{2^2} - \frac{1}{(m+5)^2} \right\}$	$m = 2, 3, 4.$			7686 H
V. Infra-red series	$n = C \left\{ \frac{1}{3^2} - \frac{1}{(m+1)^2} \right\}$	$m = 3, 4, 5.$			Bergmann OK

Here C is the general constant 109,675 derived from the Balmer or Diffuse Series as given in Equation III. This relation represents the observed lines up to $m = 30$, practically within the limits of error; the remaining equations are less correct. Fowler² has succeeded in observing the lines in the first two Principal Series and in the Sharp Series with a terrestrial source. The nature of these lines is still disputed; they are ascribed by some investigators to helium rather than to hydrogen. Two members of the Infra-red Series have been observed by Paschen.

Ritz³ has shown how, by making certain permutations, the formulæ for the Principal, Diffuse, and Sharp Series just given can be made to yield new relations which should represent new series in the Schumann region. The expression corresponding to the Diffuse Series has the form $n = C \left\{ \frac{1}{1^2} - \frac{1}{m^2} \right\}$; a Sharp Series in the extreme ultra-violet might be given by $n = C \left\{ \frac{1}{1^2} - \frac{1}{(m+5)^2} \right\}$, and a Principal Series by $n = C \left\{ \frac{1}{5^2} - \frac{1}{m^2} \right\}$, and so forth. Of these three new formulæ only the one which relates to the Sharp Series gives a term in that part of the Schumann region bounded by the transparency of fluorite, the lines belonging to the other series lying on the more refrangible side of this region. Therefore, if the speculations of Ritz represent the true state of things, it is not

¹ Fowler, "Roy. Astron. Soc.," Monthly Notices LXXIII. No. 2, 1912.

² *Ibid.*

³ "Ann. d. Phys.," 25, p. 667, 1908.

reasonable to expect that the primary spectra of hydrogen should be represented by more than one line in the region between λ 1850 and λ 1230.

It is very interesting to note that the formula $n = C \left\{ \frac{1}{1^2} - \frac{1}{m^2} \right\}$ yields lines at λ 1215.6 and λ 1025.7 for $m = 2$ and $m = 3$. Now the position λ 1215.6 lies beyond the limit set by the absorption of fluorite, so that a verification of Ritz' prediction necessitated an experiment with a disruptive discharge and an apparatus in which no fluorite occurred in the light-path. Such an experiment presented serious technical difficulties. Within the last few months these difficulties have been overcome, and it has been possible to examine the disruptive discharge in hydrogen under the desired conditions with the vacuum grating spectrocope. As a result of the investigation it was found that a line at λ 1216, which is present in the secondary spectrum, is much broadened and intensified when a disruptive discharge is employed, while the other lines in its neighbourhood are enfeebled and blurred. The position of λ 1025.7 is so near the extreme limit of the spectrum that it is difficult to make a positive statement. However, there appears to be a very faint diffuse line in the correct position.

The new work with the disruptive discharge has been chiefly of interest in connexion with the extension of the spectrum from the former limit obtained with the grating at λ 1030 to the new limit at λ 905. Improvement in technique resulted in a considerable increase in the length of the spectrum even when a non-disruptive discharge was used, but the most refrangible lines so far observed have been obtained only when a condenser and spark gap were introduced into the circuit with the discharge tube. Under these conditions several sharp lines were obtained which did not occur at all with the milder form of excitation. One of these forms the present limit of the spectrum in the extreme ultra-violet. It is impossible at present to say if the new lines belong to hydrogen or if they are due to some impurity torn from the tube or the electrodes by the violence of the discharge.

Returning to the secondary spectrum between λ 1675 and λ 1250, it is important to observe that, though under ordinary circumstances it presents a bewildering complexity of lines, yet under some conditions it is capable of very striking simplification.¹ This simplification consists of the intensification of certain groups which always occur in the many-line hydrogen spectrum. The phenomenon occurs when hydrogen is mixed with a great quantity of argon; it appears to be an example of the action of one gas on the spectrum of another. The details of the effect are as follows:—

If argon containing a trace of hydrogen at a pressure of 2 or 3 mm. is enclosed in a tube with aluminum electrodes, and if no capacity is introduced in the circuit, a characteristic spectrum is obtained. It consists of five groups, each group containing five rather strong lines. These groups begin near λ 1650 and extend to λ 1450. They are all similar in appearance, but they are not all identical in constitution. The distance between the lines in a group is of the order of from one to four Ångström units. If the last trace of hydrogen is removed from the argon, this spectrum disappears. Nitrogen, oxygen, and helium containing a trace of hydrogen and examined in a tube with aluminum electrodes do not produce these groups. If the argon and hydrogen are examined in a tube with iron electrodes, the intensity of the groups is very much reduced; if electrodes of copper are employed, the lines are extremely feeble. Under any circumstances, they are destroyed by the introduction of capacity. The most important fact in connection with these groups is that they are always found in the spectrum of pure hydrogen, no matter how this gas is prepared nor what electrodes are employed. Ordinarily they are superposed upon a great number of other lines but they may be readily distinguished from the rest of the spectrum. All the groups can be identified in the reproductions of spectra published by Schumann; the group which lies between λ 1590 and λ 1600 is the most striking, for at this point of the spectrum it is not obscured by the presence of other strong lines. That these groups are not due to some

¹ Lyman, "Astrophysical Jour.," 33, p. 105, 1911.

impurity common to all the electrodes employed has been proved by using terminals of very pure silver. The spectrum of hydrogen obtained with these electrodes is identical in every respect with the other spectra of this gas. If these groups are due to some impurity in the gas itself, such an impurity must be of a very fundamental character, for it was present in all the hydrogen which has been employed during the past five years at Harvard and it was present in the hydrogen used by Schumann.

It is conceivable that groups of this type may be present in the spectrum of argon, containing a trace of hydrogen, in the visible and ultra-violet regions. At first sight, therefore, a suspicion might exist that the "Groups of Four" observed by Rydberg¹ in argon might in reality be connected with hydrogen, but a comparison of the measurements of the argon and hydrogen spectra shows that such a suspicion is without foundation.

Kayser has observed lines belonging to the spectrum of aluminum in the spectrum of argon when aluminum was used for electrodes, but it is obvious from what has just been stated that the "Groups of Five" observed in the Schumann region cannot be supposed to have a metallic origin.

It appears plausible that these groups constitute a separate spectrum of hydrogen which usually occurs superposed on the secondary spectrum in the Schumann region but which may be separated from it under favourable conditions. The following table gives the wave-lengths and the frequencies $\left(\frac{1}{\lambda}\right)$. A study of these figures suggests a relation of constant second differences between the vibration numbers of homologous lines, but it appears that the accuracy of this relation is not quite within the limit of error of the measurements if all five groups are taken into consideration. Homologous lines in the first three groups show constant second differences which agree well within the limit, but when the third, fourth, and fifth groups are combined, a smaller value for the second difference is obtained. It will be noted, however, that all the

¹ Kayser, "Handbuch," II, p. 577.

lines in the fourth, fifth, and sixth groups show approximately the same second difference :—

Line.	Group I.			Group II.			Group III.			Group IV.			Group V.		
	I.	λ .	$1/\lambda$.	I.	λ .	$1/\lambda$.	I.	λ .	$1/\lambda$.	I.	λ .	$1/\lambda$.	I.	λ .	$1/\lambda$.
1	2	1643.0	60864	3	1599.4	62523	2	1550.6	64491	—	—	—	3	1445.2	69194
2	3	1640.5	60957	5	1596.2	62648	4	1547.0	64641	3	1495.5	66867	6	1441.0	69396
3	4	1638.2	61042	7	1593.6	62751	5	1543.9	64771	2	1491.9	67028	7	1438.0	69541
4	3	1636.5	61106	5	1591.5	62834	4	1541.6	64867	3	1489.3	67145	6	1435.2	69677
5	6	1634.1	61210	8	1589.0	62932	5	1539.2	64968	4	1486.9	67254	7	1433.0	69783

TABLE I.—SECOND DIFFERENCE.

	Involving Groups		
	I, II, III.	II, III, IV.	III, IV, V.
First line	305	—	—
Second line	302	233	303
Third line	311	237	256
Fourth line	305	245	254
Fifth line	314	250	243
Average	307	241	264

The wave-length of the line near λ 1547.0 is somewhat in doubt. Schumann's spectrograms show a complex group at this point. Some uncertainty is also introduced by the feeble nature of the fourth group; in fact, its first line is lacking probably because of its faint character. The fifth and strongest group contains faint lines at λ 1436.3 and λ 1434.3 whose counterparts cannot be recognized in the other groups.

The Rule of second differences is generally connected with band spectra. It is interesting to find that such a relation has been detected by Nicholson¹ in the measurements of Dufour² on the secondary spectrum of hydrogen in the visible and ultra-violet. Fulcher³ has isolated some of these lines or bands.

¹ Nicholson, "Monthly Notices, Roy. Astron. Soc.," Mar., 1914, p. 427.

² Dufour, "Jour. d. Physique," p. 258, 1909; "Ann. Chim. Phys.," p. 416, 1906.

³ Fulcher, "Astrophysical Jour.," Jan., 1913.

Oxygen.—Schumann¹ states that the spectrum of oxygen "is compounded of three continuous maxima of which the most refrangible is the strongest. It lies about λ 1850. The observation of these maxima is attended with considerable difficulty on account of their slight photographic efficiency and because of the bands of oxide of carbon which appear with them." Steubing² has investigated the emission of oxygen at the edge of the Schumann region, and has found a series of lines or bands identical with those which he attributed to the fluorescence of the gas. He believes that these sharp emission lines are related to the continuous maxima mentioned by Schumann.

Oxygen has been repeatedly studied with the vacuum grating spectroscope³ under various conditions. No lines or bands were observed between λ 2000 and λ 1230. The strong absorption of the gas in the part of the vacuum tube between the capillary and the window may account for the result.

The continuous maxima observed by Schumann are, undoubtedly, a real phenomenon. The reality of the sharp emission lines observed by Steubing has been questioned by Kayser.

On the edge of the Schumann region the most refrangible known lines are those measured by Schneiderjost⁴ at λ 2112.4 for the compound spectrum and λ 2224.5 for the line spectrum.

Nitrogen.—This gas possesses a band spectrum extending throughout the ultra-violet. In the Schumann region "its emission spectrum consists of a number of groups of bands of moderate photographic power, shading off toward the shorter wave-lengths and ending on the less refrangible side of λ 1850."⁵ Here the words "shading off" probably refer to the change of intensity from band to band.

It has been possible to follow these bands with the grating spectroscope to the region of λ 1380.⁶ They are faint, their heads being directed to the more refrangible part of the

¹ "Smithsonian Contributions," 1413, p. 16.

² "Ann. d. Phy.," 33, p. 553, 1910.

³ Lyman, "Astrophysical Jour.," 33, p. 98, 1911.

⁴ Kayser, "Handbuch," VI, pp. 212-18.

⁵ Schumann, loc. cit.

⁶ Lyman, loc. cit.

spectrum; their wave-lengths are given in Table II. They are seen to best advantage when the discharge tube circuit is without capacity.

When a disruptive discharge is used the band spectrum disappears and two pairs of sharp lines become the dominant feature of the spectrum. These lines have been ascribed to nitrogen since, though they occurred in several gases with a condenser discharge, yet they became weaker as traces of nitrogen were removed. Recently Wolff states¹ that he has obtained the less refrangible of these pairs in the spark spectra of silica, and more faintly in aluminum and carbon. He attributes this pair, therefore, to silica. Now, in the spectra from vacuum tubes the results obtained with a condenser discharge are always somewhat difficult to interpret because of the contamination of the gas due to the disintegration of the glass. Therefore, Wolff's explanation is very plausible. On the other hand, it may well be that when these lines are found in the spark they occur as "Air lines," and are due to the medium which surrounds the electrodes, not to the electrodes themselves. Certain it is that these lines occur² far more strongly in an aluminum spark in air than an aluminum spark in hydrogen. They also occur with a barium spark when the metal was free from silica in an atmosphere of helium which was known to contain nitrogen.

The most refrangible line of nitrogen outside the Schumann region occurs at λ 2052.7.³

Oxides of Carbon.—In the extreme ultra-violet the spectra of two gases only are readily obtained; the one is due to hydrogen, the other to a compound of carbon. This latter spectrum consists of a great number of bands; it appears to begin in the ultra-violet near λ 2100 and extends to the neighbourhood of λ 1300. It was early recognized by Schumann. It has also been studied with the grating spectroscope; ⁴ the resulting wave-length measurements are given in Table III.

¹ "Ann. d. Phys.," 42, p. 838, 1913.

² Lyman, "Physik. Zeitsch.," 13, p. 584, 1912.

³ Kayser, "Handbuch," V, p. 834.

⁴ Lyman, "Proc. Am. Acad.," 45, p. 315, 1910.

These data are valuable since they afford points of reference in the region between λ 1854 and λ 1675 where few lines exist.

The appearance of the spectrum is shown in Plate VIII, Volume 13, of the "Memoirs of the American Academy." It is marked "Air," because the carbon compound which gives rise to it is usually found in discharge tubes which have been exhausted for the first time. The bands are most intense in the less refrangible region, but they are all of the same general type with heads directed toward the region of shorter wavelength. The strongest bands are evidently double. The system, at least throughout its less refrangible part, forms a continuation of the "Fourth Group" as described by Deslandres in his paper, "Spectre de bandes ultra-violet des composés hydrogénés et oxygénés du carbone."¹ The spectrum under investigation is thus related to the series of bright bands in the visible and the ultra-violet attributed to carbon monoxide and often observed in ill-prepared vacuum tubes.

It is only too easy to obtain the bands in the region of short wave-lengths, for, to quote Schumann himself,² they are "the unwelcome attendants of all my spectra." In order to determine the cause of the phenomenon, however, experiments were made with both carbon monoxide and carbon dioxide and with a variety of conditions in the discharge tube. The results of these experiments may be stated as follows: Exactly the same bands are obtained when carbon monoxide is used as when carbon dioxide is employed, but in the former case the strength of the whole spectrum is considerably greater than in the latter. With increased current strength from a transformer, between five and twenty milliamperes, the intensity of the bands increases in a uniform manner throughout the extent of the spectrum. When a spark gap is placed in series with the tube and a condenser is introduced in such a way as to produce a disruptive discharge, the spectrum at first weakens and then vanishes altogether.

The effect is accomplished by a very marked decrease in pressure in the tube and by the formation of a dark deposit on the walls of the capillary. These experiments go to con-

¹ "Comptes Rendus," 106, p. 842, 1888.

² Loc. cit., p. 16.

firm the results of Schumann, as they show that the spectrum is due to carbon monoxide. The occurrence of the bands when carbon dioxide is present may be explained by the fact that this gas is known to be transformed into carbon monoxide under the influence of light and the electric discharge.¹ The disappearance of the spectrum with the disruptive discharge is due to the destruction of the carbon monoxide. The oxygen set free by the reaction seems to combine with the electrodes, while the carbon is deposited. This property of a condenser discharge is useful, since it permits the spectroscopist to free his apparatus of an annoying impurity. The decrease in pressure which accompanies this reaction is often a striking and important phenomenon.

In addition to their value as standards of wave-lengths the results are of some theoretical importance. Deslandres in the paper just quoted has used his measurements of the carbon spectrum to test his "Rules". As the spectrum under discussion seems to form a continuation of that described by Deslandres, it is interesting to see if its bands also show the numerical relations described by the earlier investigator. In making the comparison, however, it is necessary to confine the attention to those relations which deal with the heads of the bands, for the dispersion employed did not permit of the study of the lines of which each band is composed. It must also be remembered that the region of high frequencies is not perfectly adapted to such a test, since a small error in the wave-length is magnified in relations which deal with frequencies.

The laws under discussion are two in number: first, that a group of bands may be broken up into sets of series such that the differences in frequency of the heads of the bands in any one series form an arithmetical progression; second, that all the series are similarly constructed. The first rule may obviously be stated in another way—the second differences of the frequencies of the heads of the bands in any one series are constant.

Deslandres has analysed his "Fourth Group" into five series, characterized by small and not very regular second

¹ Hirschfinkel, "Comptes Rendus," 149, 395, 1909.

differences. With the aid of the measurements in the extreme ultra-violet, it has been found possible to follow the arrangement into the region between λ 2000 and λ 1600 and to add seven new series of the same type.

On the more refrangible side of λ 1600, however, matters are not very satisfactory. The bands must be arranged into series showing very large second differences which are only approximately constant. These series might be considered as constituting a "Fifth Group."

The spectrum contains a great many bands which are either too feeble to measure or whose positions are made uncertain by the tails of stronger bands; if these could be included in the series a better system would probably result.

Helium.—This gas has been investigated with the grating spectroscope in a vacuum tube¹ at pressure varying from 17 mm. to 1 mm. and with continuous currents and a disruptive discharge. The results were negative. No line could be attributed to helium in the region between λ 2000 and λ 1250. This conclusion has recently been confirmed, in part, by Wolff.² It must be noted, however, that when an aluminum spark is produced in helium at a pressure of about $\frac{1}{2}$ of an atmosphere, two lines which could not be attributed to aluminum made their appearance. One was of great intensity; it occurred at λ 1656.8; the other was less strong, its wavelength being λ 1561.2. The first line has been observed very faintly with the aluminum spark in air and with calcium in hydrogen; the second has also been found faintly in calcium. It seems probable that these lines are due to an impurity, but it is curious that they should be so greatly enhanced in helium.

The most refrangible line recorded in the helium spectrum has the value λ 2644.9.³

Argon.—This gas has been studied with the grating.⁴ The wave-lengths corresponding to the "blue" spectrum obtained with pressure of 1 or 2 mm. and a disruptive discharge are to be found in Table IV. The lines, thirty-nine

¹ Lyman, loc. cit.

² Loc. cit.

³ Kayser, "Handbuch," V, p. 518.

⁴ Lyman, loc. cit.

in number, extend from λ 1886 to λ 1333. They present nothing very striking either in relative position or distribution of intensity.

Only three lines have been obtained when the gas was examined at high pressures (1 or 2 cm.) with a disruptive discharge. This procedure results in the so-called "white" spectrum in the visible. Of the three lines, two are also found in the blue spectrum, and the third, at λ 1850, nearly coincides with the mysterious line which is obtained in hydrogen with a condenser discharge; it may well have been due to a trace of that gas which happened to be present in the particular sample of argon under investigation.

There is nothing corresponding to the "red" spectrum in the Schumann region.

In this connexion it is interesting to contrast the behaviour of hydrogen with that of argon. With the former gas, a characteristic line spectrum is produced when no capacity is included in the circuit, while with a disruptive discharge these lines almost completely disappear and no new ones take their place, at least on the less refrangible side of λ 1300. With the latter gas, just the opposite conditions prevail. Argon gives no lines in the Schumann region when the circuit is without capacity; it is only with a disruptive discharge that its characteristic lines appear.

The most refrangible line¹ on the edge of the Schumann region has the value λ 2050.5; it belongs to the blue spectrum.

¹ Kayser, "Handbuch," V, p. 74.

CHAPTER IV.

EMISSION SPECTRA OF SOLIDS.

THE spark and arc spectra of most metals are particularly rich in ultra-violet radiation; very complete tables of the wave-lengths of their lines exist to the region of λ 2000, and, in a number of cases, measurements have been carried to the limit set by the absorption of the air. In fact, for a long time the pair of lines in the spark spectra of aluminum, first observed by Stokes, formed the limit of the known spectrum in the ultra-violet.

Very early in his researches Schumann¹ studied the spark spectra of a great number of metals, but he gave no wave-lengths for the lines he discovered, and his apparatus, which at that time was crude, did not permit him to follow the investigation much beyond the limit attained by Stokes. Later, when he had perfected his spectroscope, he returned to the subject. Some of his results for cadmium and for aluminum² are shown in Plate II, Vol. 102, IIa, Proceedings of the Vienna Academy, p. 694. The most refrangible of the rays there represented has a value λ 1670. The study of all spark spectra in the extreme ultra-violet is beset by an obvious difficulty, for the layer of air which surrounds the spark absorbs the light energetically before it can enter the vacuum apparatus. Schumann attempted to surmount this difficulty by producing the spark in hydrogen.³ His first attempts were not very successful, probably because he tried to work with the hydrogen at low pressures, a procedure which greatly weakens metallic lines. He soon abandoned the spark as a source of light and turned his attention to the discharge tube with which he suc-

¹ "Ber. Akad. Wis. Wien.," 102, IIa, p. 438.

² Kayser, "Handbuch," III, p. 339.

³ "Ber. Akad. Wis. Wien.," 102, IIa, p. 438.

ceeded in obtaining such brilliant results. Had not illness overtaken him, he would have doubtless returned to the subject of the emission of solids.

The early work at Harvard added hardly anything to the knowledge of spark spectra, for the extension of the hydrogen spectrum and the measurement of its lines fully occupied the attention of the observer. Handke,¹ in Berlin, was the first to make systematic measurements. Using a vacuum prism spectroscope of the Schumann type, he attached to it a vacuum tube of the form used at Harvard. This tube was filled with hydrogen and served to produce a standard spectrum. The spark was formed in air in such a way that the light passed through the discharge tube before entering the spectroscope. Thus the extent of the spectra was limited by the absorption of the layer of air between the spark and the window of the discharge tube. His most refrangible line lies at λ 1594. All his results rest on the measurements of the hydrogen spectrum. He studied the spectra of Al, Cu, Au, Ag, Sn, Zn, Mg, and Hg. His measurements will be found among the tables at the end of the book.

The next work in the emission of solids was done with the vacuum grating spectroscope in order to verify certain predictions as to the construction of the spectra of the alkali earths.² The method adopted was a distinct improvement over the procedure of the earlier investigators in that, by placing the spark in hydrogen at atmospheric pressure, the absorption of the air was removed, and it thus became possible to follow spark spectra much farther into the extreme ultra-violet than had been possible before. See p. 41. The most refrangible line obtained by this method had the value λ 1238, a position very close to the limit set by the fluorite window which it was necessary to employ.

It is important to note that, though during these experiments the primary spectrum of hydrogen was always present in the visible and sometimes extremely brilliant, yet no lines which could be ascribed positively to a primary spectrum in

¹ "Berlin Inaug. Dis.," 1909.

² Lyman, "Astrophysical Jour.," 35, p. 341, 1912.

the Schumann region appeared. In this connexion the reader is advised to consult the plate in the original article, which gives a good idea of the spark spectra in question. It also exhibits the secondary spectrum of hydrogen by way of comparison.

Aluminum was chosen as the first substance for investigation because its spectrum has been studied by Handke, and it therefore afforded opportunity for comparing the grating measurements with measurements obtained by another type of instrument. The figures which will be found in Table V illustrate in some degree the relative advantages of the two methods of experiment. The greater light-intensity of the prism instrument in the region of wave-lengths less refrangible than λ 1600 is shown by the fact that some faint lines are given by Handke which are not easily observed with the grating. On the other hand, the result of the elimination of the absorption of the fluorite prism and lenses and of the air near the spark is illustrated by the fact that the lines of shorter wave-length than λ 1600 measured with the grating were not discovered in the earlier work. Between the two sets of measurements the agreement is fair; with the exception of six lines, the difference between Handke's values and those of the writer are four-tenths of an Ångström unit, or less. The greatest differences occur between λ 1700 and λ 1750, a region in which Handke was at a considerable distance from the 1854 line on the one side and the hydrogen spectrum on the other. However, it is only fair to remember that the values obtained with the grating were measured by the "shifted spectra" method, and not by direct comparison with the hydrogen spectrum, and there seems some reason to believe that as compared with the hydrogen standard they may be about $\frac{1}{2}$ of a unit too low.¹

Lines have been measured by Morris Airey,² and attributed by him to aluminum; they cannot be recognized on the spectrograms of Schumann or of Lyman, and they do not occur

¹ Wolff, loc. cit. "Ann. d. Phy.," 42, p. 836.

² "Proc. Manchester Phil. Soc.," 49, p. 1, 1904.

among Handke's wave-length values. They are probably due to some instrumental error.

An inspection of the aluminum spark spectrum from the grating shows that the well-known pair at λ 1862, λ 1854 are by far the strongest lines in the field. The other lines decrease in intensity with decrease in wave-length. There is no striking regularity of arrangement.

After the work with the spark in hydrogen was completed, an investigation by Lenard¹ on volume ionisation renewed the interest in the nature of the aluminum spark in air. It has been shown that the ability to produce volume ionisation by light increases in the Schumann region with decrease in wave-length; in fact, some investigators go so far as to assert that the phenomenon only occurs when light on the more refrangible side of λ 1400 is employed. Now Lenard obtained very strong ionisation when he used a very powerful spark between aluminum terminals, and his results indicated that the effective light lay in the extreme Schumann region. On consulting the data for the aluminum spark in hydrogen, it was obvious that no strong lines existed in the extreme ultra-violet. Unless, therefore, lines were to be found in the spectrum of the aluminum spark in air which were not present with the spark in hydrogen, Lenard's results could not easily be explained. New experiments were accordingly undertaken with the grating spectroscope²; they yielded more interesting results than any of the previous attempts of this character. Their success was due to the fact that the pointed spark terminals were placed nearly in contact with the window of the spectroscope, so that the spark played against the surface of the fluorite. An exposure of six minutes destroyed the fluorite window, but a strong spectrum was registered on the photographic plate.³ Between λ 1400 and λ 1900 the lines of this spectrum are the same as those observed when the spark was in hydrogen, but there is a distinct difference in the distribution of intensities in the two spectra in this region, owing

¹ Lenard and Ramsauer, "Sitz. Heidelberg Akad. d. Wiss. Abhand.," 31, 1910.

² Lyman, "Physik. Zeitsch.," 13, p. 583, 1912.

³ See Frontispiece, Nos. 2 and 3.

to the selective nature of the absorption of the air and to the difference in intensity of certain "air lines." Near λ 1300, with the spark in air, there is a group of strong lines not observed with the aluminum spark in hydrogen. It is to this group that the ionisation effects observed by Lenard are largely to be attributed. All the lines in the region of λ 1300 cannot be assigned to the same cause. Those at λ 1302.0, λ 1304.8, λ 1305.8, λ 1334.6 and λ 1335.7 are found faintly with magnesium in hydrogen. They seem of uncertain origin and are so listed in Table V. The lines λ 1275.0, λ 1276.4, λ 1310.8, λ 1319.4 are provisionally placed under aluminum, but it is very probable that they are of gaseous origin. The fact that the aluminum spark spectrum is often accompanied by "air lines" in the visible and ultra-violet lends colour to this theory. It must also be remarked that Lenard found several metals produced nearly the same ionising effects when used as spark terminals, a result which would indicate that all the effective rays were not produced by the metals themselves.

Returning to the grating investigation of the spectra of the alkali earths and their series relations, the expectations in the Schumann region based on theoretical considerations are of two kinds¹. First, according to the speculations of Ritz and of Saunders, there should be series of pairs in the region of very short wave-lengths, the subordinate members of which show constant wave-number separations. Lines belonging to this arrangement have already been observed over the ordinary extent of the spectrum in calcium, strontium, barium, and magnesium, and in the case of some of the series the constants of the formulæ have been calculated with a sufficient degree of accuracy to permit of a rough prediction of the position as well as the separation of the new pairs.

The expectation of the second kind is less definite in character than the first. It is founded on the following statement of Saunders:² "In all three elements there occurs a strong pair in the ultra-violet: Ba λ 2335 and λ 2304 ;

¹ Ritz, "Physik. Zeitsch.," 9, p. 521, 1908.

² "Astrophysical Jour.," 32, p. 165, 1910.

Sr λ 2165 and λ 2152; Ca λ 1840 and λ 1837, which are reversed in Sr and Ba, and probably in Ca also, and the line of greater wave-length is the stronger in each. They therefore look like subordinate-series pairs in a series of great strength, the rest of which is in the Schumann region."

Calcium.—With this substance experiment revealed four new pairs in the Schumann region with the separation required by theory, wave-number $1/\lambda = 223$. They appear to fall in with the expectation of the first kind and form terms in the first and second subordinate series. In the case of the expectation of the second kind, three new pairs were found with the separation predicted by Saunders, $1/\lambda = 70$. These pairs, four in all, may present material for the application of the "combination principle." After lines due to impurities have been eliminated, there remain some ten or twelve lines in calcium unclassified, most of which are faint. The wave-lengths are given in Table VI.

Strontium.—In the case of this metal, the expectation of the first kind is slight. The computations of Saunders show that the limits of the subordinate series lie in the neighbourhood of λ 1700; it is recognized property of these series that the members rapidly decrease in intensity as they near the limit. It is not surprising, therefore, that only one pair with the required separation, $1/\lambda = 800$, in the Schumann region has been observed. The position is λ 1847 and λ 1820. The expectation of the second class, however, has been well fulfilled. There are two striking pairs, with the predicted separation, $1/\lambda = 285$.

These three pairs constitute the spectrum of strontium; the other lines which occur on the plate are chiefly due to calcium and aluminum.

Barium.—With this metal the experimental difficulties are very great. Success was attained only by using the pure metal in an atmosphere of helium. What has been said of strontium applies even more strongly in this case. The expectation of the first kind is very small. The expectation of the second class is apparently fulfilled: two pairs with the separation predicted by Saunders exist. That they belong

together is not absolutely certain, though it seems extremely probable. In addition to these lines, there are several others which may be due to barium (Table VIII).

Magnesium.—The spectrum consists, in the Schumann region, of only two pairs, separation $1/\lambda = 90$; they seem to fulfil the expectations of the first class and form members of the first and second subordinate series mentioned by Ritz.¹ The other lines visible on the plate are due to impurities. The results of Handke do not agree with the data obtained with the grating. Perhaps the fact that the spark was in air in the one case and in hydrogen in the other may account for this (Table IX).

Mercury.—The only work on the spark spectrum of this substance was done with the vacuum grating spectroscope at Harvard.²

The arrangement for studying the spectrum was exactly similar to that employed in the work on the spectra of the alkali earths. A strontium amalgam, a barium amalgam, and a globule of mercury were used successively as terminals. The spark was in an atmosphere of hydrogen. The spectra are characterized by numerous lines extending from λ 1876 to the limit set by the transparency of fluorite. All the strong lines lie between λ 1876 and λ 1650. The lines do not present any very obvious regularity of arrangement.

The strontium amalgam contained 75 per cent of mercury. The barium amalgam contained 80 per cent of mercury. When pure mercury itself was employed, it was held in a steel cup; the upper electrode was a point of soft steel. The three spectra obtained in this way are nearly identical. The spectrum from pure mercury, however, is quite feeble on the more refrangible side,—in fact, beyond λ 1750 all the lines are very faint and the group beyond λ 1350 cannot be seen at all. This is probably due to the absorption of the metallic vapour round the spark. That the lines between λ 1750 and λ 1260 are due to mercury itself is proved by the behaviour of the amalgams. For, though the

¹ "Physik. Zeitsch.," 9, p. 528, 1908.

² Lyman, "Astrophysical Jour.," 38, p. 282, 1913.

strontium amalgam was of rather doubtful character, the barium amalgam was known to be pure. The spectra of these two substances were identical; it seems probable, therefore, that their common spectrum is due to their common ingredient, namely, mercury.

Table X contains the wave-lengths in vacuum with the frequencies added for the convenience of those who may be interested in computations connected with series spectra. The line λ 1849.6, so strong in the arc, appears in the amalgam spectrum as a faint band; it is reversed in the spark from mercury itself. Of the remaining six arc lines, only two surely appear in the spark. The values in the table have been compared with those for aluminum, iron, and the alkali earths, and it is hoped most of the impurities have been eliminated. The measurements were made by the method of shifted spectra. The absolute position of the lines should not be in error by more than three-tenths of an Ångström unit.

Work on the mercury spectrum from a vacuum tube in the region below λ 1900 has been carried on only at pressures under 3 or 4 mm. and has been mostly incidental to the study of gas spectra. Only one line has been recognized, that at λ 1849.6.

Iron.—The study of this substance has been incidental to the work on other metals.¹ The spectrum consists of a considerable number of lines scattered throughout the Schumann region, the strongest lie near λ 1800. There is a group, however, made up of numerous members at the most refrangible limit as set by fluorite. No wave-length measurements have been made in the spectrum.

ARC SPECTRA.

All the work on Arc Spectra is of very recent date. Paschen² has shown that certain lines in the spectra of Zinc, Cadmium, and Mercury may be arranged to form Principal Series given by formulæ of a type which has become standard

¹ Lyman, "Astrophysical Jour.," 38, p. 282, 1913.

² Paschen, "Ann. d. Phy.," 35, p. 860, 1911; 40, p. 602, 1913.

in series spectra investigations. The lines lie in a well-known region and their wave-lengths have been determined with precision; from these measurements it has been possible to calculate accurately the constants which enter into the formulæ in question. Paschen¹ pointed out that the change of one parameter in these formulæ, in a manner justified by analogy with other similar relations, would yield Principal Series whose members occurred in the Schumann region. Inspired by this prediction Wolff² has studied the arc spectra of Zinc, Cadmium, and Mercury by means of a prism vacuum spectro-scope of the same general design as that used by Schumann.

It is obvious that the arc must be formed either in vacuo or in some transparent gas; the first alternative was chosen by Wolff. The chief experimental difficulty which beset the use of the arc at reduced pressures is the formation of metallic films on the window which separates the arc chamber from the body of the spectro-scope; this difficulty is particularly acute when the extreme ultra-violet is the region to be investigated. Wolff overcame the difficulty by employing a modification of the quartz amalgam lamp first described by Stark.³ The formation of the film was prevented by the application of a cooling chamber to that part of the lamp which lay between the arc and the window. An arrangement was also introduced whereby the hydrogen spectrum could be superposed upon that of the metal under investigation. This lamp served for the study of Cadmium and Zinc; in the case of mercury, a lamp of somewhat different shape was used; it was entirely immersed in a cooling bath.

The wave-length measurements were referred to the aluminum lines in the region from λ 1990 to λ 1854 as given by Runge, and Eder and Valenta; from there on to λ 1670 they rested on the values of aluminum spark spectrum as determined at Harvard. On the more refrangible side of this point, the values for the hydrogen spectrum were taken as standards.

The values given by Wolff are to be found in Tables XI and XII. They confirm the predictions of Paschen to a won-

¹ Loc. cit.

² *Ibid.*

³ "Physik. Zeitsch.," 6, p. 438, 1905.

derful degree of accuracy, as may be seen from the following tables :—

Zinc : Principal Series. Single Lines ($1\cdot5 S - mP$).

m	3	4	5	6
λ calculated	1589 \cdot 64	1457 \cdot 64	1404 \cdot 18	1376 \cdot 97
λ observed	1589 \cdot 76	1457 \cdot 56	1404 \cdot 19	1376 \cdot 87
Diff.	0 \cdot 12	0 \cdot 08	0 \cdot 01	0 \cdot 1

Cadmium : Principal Series. Single Lines ($1\cdot5 S - mP$).

m	3	4	5	6	7
λ calculated	1669 \cdot 30	1526 \cdot 73	1469 \cdot 35	1440 \cdot 15	1423 \cdot 22
λ observed	1669 \cdot 29	1526 \cdot 85	1469 \cdot 39	1440 \cdot 18	1423 \cdot 23
Diff.	0 \cdot 01	0 \cdot 12	0 \cdot 04	0 \cdot 03	0 \cdot 01

Mercury : Principal Series. Single Lines ($1\cdot5 S - mP$).

m	2	3
λ calculated	1849 \cdot 6	1402 \cdot 71
λ observed	1849 \cdot 57	1402 \cdot 72
Diff.	0 \cdot 03	0 \cdot 01

Besides the members of these three Principal Series, there is also a Combination Series in each of the three metals: one term of such an arrangement has been found for zinc, two for cadmium, and one for mercury.

So confident is Wolff of the accuracy of values derived from Paschen's formulæ that he applies a correction to the hydrogen wave-lengths by comparing his wave-lengths, as determined from hydrogen, with the calculated values which he assumes correct.

The maximum correction applied in this way is 0 \cdot 12 units, a value rather too flattering to the accuracy of the measurements of the hydrogen spectrum, since the wave-lengths only claim an accuracy of 0 \cdot 2 of a unit at best.

The spectrum of the mercury arc has also been investigated with the vacuum grating spectroscopie at Harvard.¹ Two forms of mercury arc were employed. In one, the whole vessel was of quartz, and the light entered the spectroscopie through the side of the lamp. In the other, the vessel was of glass fitted with a fluorite window. The spectrum is dominated by the broad unsymmetrical line at λ 1849 \cdot 6, which

¹ Lyman, "Astrophysical Jour.," 38, p. 282, 1913.

considerably exceeds in strength any single line in this region in the spectrum of any substance heretofore examined. The line is easily reversed, a fact which has already been noted by Tian.¹ The other six lines which go to make up the arc spectrum, though much inferior in intensity, are still fairly strong.

The relation between the arc and the spark spectra is what one would expect from the behaviour of mercury in the visible and ultra-violet, for the spark spectrum is rich in lines and the arc spectrum contains but few.

As has been just said, the lines at λ 1849.6 and λ 1402.5 are the two first members of the Principal Series predicted by Paschen; the third member, which should occur at λ 1268.9, is within the limit of the transparency of fluorite, but was not found. This was to be expected, for, as the intensity falls off very rapidly between λ 1849.6 and λ 1402.5, the next line in the series must be very faint indeed. The member of the Combination Series found by Wolff at λ 1435.6 was not observed with the grating.

Hughes² predicted the nature of the spectrum of the mercury arc in the Schumann region, basing his conclusions on photo-electric data. Later experiments³ have somewhat changed his numerical values. Neither the original prediction nor the corrected data agree accurately with the spectrum as actually observed.

Following the usual practice, the observations which have just been discussed were obtained after the spectroscope had been repeatedly exhausted and washed with dry hydrogen. If a photograph was taken with air in the spectroscope, the appearance of the line at λ 1849.6 was profoundly modified. The broad line, which often extended over thirty Ångströms, was now replaced by three groups of rather faint, sharp lines. This is, undoubtedly, the phenomenon observed by Steubing,⁴ and this is the phenomenon which all investigators will

¹ "Comptes Rendus," 155, p. 141, 1912.

² "Phil. Mag.," 21, p. 393, 1911.

³ "Phil. Trans. Roy. Soc. Lond.," 212, p. 205, 1912.

⁴ "Ann. d. Phy.," 33, p. 572, 1910.

observe who work with an apparatus in which the light from the mercury arc must traverse a considerable air-path before falling on the photographic plate. It is possible that some of Tian's¹ measurements refer to the strongest of these lines or bands. Except for these lines, there is nothing visible in the mercury arc below λ 1900 when investigated through air.

Steubing has attributed the lines to the fluorescence of oxygen, and their narrowness and sharpness lend colour to this interpretation. It is probable, however, that the effect is produced by the absorption of the air after the light has passed through the slit of the spectroscope.² It is important to remember in this connexion that Schumann observed "that oxygen absorbs the rays in the neighbourhood of $185 \mu\mu$ in a series of clearly resolved groups of lines fourteen in number." The strong and broad mercury band at λ 1849.6 would form an excellent background for the detection of such lines.

Absorption must enter into the phenomenon, even if Steubing's view is correct.

When the mercury arc in quartz is employed in photo-chemical, biochemical, and photo-electric experiments, it is obvious that very different results may be expected if the light has to traverse a short air-path from those which will result if the air-path is long. In the first case, the full energy of the great line at λ 1849.6 will be effective; in the second, only the feeble action of Steubing's lines will be felt. It is well for workers in these fields to bear this fact in mind. Experiments show that biochemical, like photo-electric action, increases with decrease in wave-length. It is, therefore, this line λ 1849.6 which, of all lines in the mercury spectrum, is the most active in producing *abiotic* effects when the organisms under observation can be brought into close proximity to the lamp. In this connexion, one must remember that even fused quartz is often sufficiently transparent to transmit this radiation strongly. On the other hand, it must not be forgotten that water in thickness of even 1 mm. is very opaque

¹ "Comptes Rendus," 152, p. 1483, 1911.

² L. and E. Bloch, "Comptes Rendus," 158, p. 1161, 1914.

at λ 1850.¹ The scarcity and feeble nature of the other lines in the Schumann region render the mercury arc inefficient in producing effects which depend on shorter wave-lengths. For example, the light from the mercury arc produces far less volume ionisation than results from the use of a hydrogen tube.

With a lamp made entirely of quartz, the line λ 1774.9 is the most refrangible radiation on the plate. The fact that the spectrum terminates at this point is probably due to two causes: first, the absorption of the quartz, and second, the absorption of the dense mercury vapour itself. The broad line or band at λ 1849.6 is always unsymmetrical, the maximum of intensity lying well toward the more refrangible side. With the quartz lamp, the band is always strongly reversed; the width of the whole band is usually about 30 or 40 units; the reversed portion is about 6 units wide.

When the lamp with the fluorite window was employed it was constantly kept in connexion with a vacuum pump; even then, the line at λ 1849.6 was sometimes reversed. It was also very sensitive to the presence of films on the window. This may partly explain the decay of the efficiency of the mercury arc with time, which has been recorded by several observers. In the quartz arc, however, where the whole system remains very hot, the formation of films is probably not the important factor. The observed effect may well be due, in part, to a change in the quartz itself under the action of the ultra-violet light similar to that which has been observed with fluorite. With this substance, long exposure in the Schumann region will turn transparent, colourless fluorite into an opaque modification of a purple tinge. Dr. Nutting has observed the same change of colour with glass.

It is interesting to note that Steubing's lines were obtained both with the quartz lamp and with the arc at low pressures.

Table X gives the wave-lengths of the arc lines in vacuum. The line at λ 1849.6 was measured by direct comparison with the spark lines of aluminum. The other wave-lengths were found by comparison with a shifted spectrum of iron. Owing

¹ Lyman, "Nature," 84, p. 71, 1910.

to the broad character of the arc lines and to the strong background due to scattered light, the setting error is larger than in the case of spark lines and the results may not be so accurate.

Estimating the intensities which are given in the fourth column is a difficult matter. The line at λ 1849.6 is vastly stronger than any of the others and the fact is indicated by the expression > 100 . The line marked "8" appears to have the same intensity as a line marked "8" in the hydrogen spectrum lying in the same region. It is obvious that these numbers give but a rough measure of the relative intensities.

The agreement between the grating values and those obtained by Wolff is as close as could be expected, considering that the former were not made by direct comparison with the hydrogen spectrum.

CHAPTER V.

PHOTO-ELECTRIC PHENOMENA. THE LIMIT OF THE SPECTRUM.

THE preceding pages have given some account of the properties of light of very short wave-length from the point of view of the student of spectrum analysis. The scope of the work does not permit of a detailed treatment of photo-chemical, photo-electrical and photo-abiotic phenomena, but, as they attain very striking proportions in the Schumann region, a brief description of their variation with the wave-lengths of the exciting light is here included.

Attention has already been called to the rapid increase in ozone-producing power as one proceeds into the region on the more refrangible side of λ 1850. Much the same thing is observed in photo-electric action, though to an even greater degree.¹ In the case of volume ionisation the effect is so striking and so easily shown to an audience that the apparatus itself merits description. A discharge tube like that illustrated on page 66 is closed by the usual fluorite window; directly above this is arranged a separate chamber or screen cell about 1 cm. thick which is, in turn, closed with fluorite. The discharge tube must be filled with hydrogen to a pressure of 2 or 3 mm. A gold leaf electroscope of any simple type has for its terminal electrode a strip of metal about 1 cm. wide by 3 cm. long, which, protruding from the metallic case, is protected by a gauze cylinder. This strip is placed within 5 or 6 cm. of a window of the screen cell just mentioned, a blast being arranged to sweep the window and to carry the air from its neighbourhood through a hole in the gauze cylinder against the strip. If now the screen cell is full of air and the blast turned on, no effect is produced in the leaves of the electroscope when the discharge tube is excited, but if the cell is exhausted the leaves of the spectroscopie collapse

¹ Lyman, "British Association Report," p. 134, 1909.

quite rapidly. The cell when filled cuts off the Schumann rays, but when it is exhausted it allows the rays to pass and they produce volume ionisation in the surrounding gas. The fact that a thickness of about 1 cm. of air is sufficient to stop the action entirely, shows that the active rays belong in the region on the refrangible side of λ 1850. The experiment is a crude adaptation of the more complex procedure employed by Palmer.¹

Turning to the bacteriacidal properties of light the action has long been known to increase with decrease in wave-length and a great mass of information has been accumulated relating to the less refrangible side of λ 2000, the use of a quartz mercury lamp for the sterilization of water being a good illustration of an application of this knowledge to a practical problem. A rather simple experiment may be performed to illustrate the fact that the action continues to increase in a striking manner after the Schumann region is entered. A discharge tube filled with hydrogen and closed at one end with fluorite is placed under the stand of a microscope in such a way that the field of vision may be illuminated by a beam of light from a small arc lamp arranged to pass directly through the tube. Some mobile form of organism such as the infusorian-like Colpoda or the swarmspore-like Spherella is placed in a drop of water on this fluorite window, the motions of the organisms may then be watched through the microscope. If now, while one of these bodies is the field of view, the discharge tube be excited by an alternating current of say 10 milliamperes, the power of motion is almost immediately lost. In many cases an exposure of two or three seconds is sufficient to produce the result. With Colpoda, not only does motion cease but the whole body breaks down and becomes miscible with the water. This destruction of cell structure is by no means confined to the organisms just mentioned, it may be seen in a great variety of tissue. It is only necessary that the specimen would be penetrable by the active rays. The experiment may be modified by interposing a screen cell of air of the kind already described or by the use of a thin plate of rock-

¹ "Physical Rev.," 32, p. 1, 1911.

salt between the source of the Schumann rays and the specimen. In this way it is easily shown that the active rays lie for the most part on the more refrangible side of λ 1750. By the use of a micro-projection in connexion with a discharge tube of special form, it is quite possible for a number of persons to see the phenomena at the same time.

The strong abiotic action of the hydrogen spectrum in the extreme ultra-violet has an interesting bearing on the hypothesis which maintains that living organisms may be transported through interplanetary space. For it is obvious that if light of the proper wave-length escape from the sun the space in question would be effectively and continually sterilized. The lack of atmosphere and of heat is no bar to the action, for it has been shown that oxygen and moisture are not necessary to this bacteriacidal phenomenon and that abiotic action continues at the temperature of liquid air. It might be contended that the gases which surround the sun effectively prevent the escape of Schumann rays, but if sun spots are accompanied by jets of burning hydrogen projected through the solar envelope, this objection falls to the ground. The burning hydrogen would provide the necessary abiotic rays. In short, it seems probable that interplanetary space is a germ-free space.

Apart from the points of general interest connected with photo-chemical, photo-electric, and photo-abiotic effects, the Schumann region offers an excellent field for measurements of very high theoretical importance. Einstein¹ has given the formula $\frac{mv^2}{2} = hn - p$ connecting the velocity v with which electrons leave a metal with the frequency of the light n which sets them free. The relation is based on the theory of "quanta," and if it can be proved to be exact it will serve as an important confirmation of this hypothesis. A good deal of work has been done on the problem using light on the less refrangible side of λ 1840, but though the results obtained point toward the correctness of Einstein's formulæ, the ques-

¹ "Ann. d. Phy.," 20, p. 199, 1905.

tion cannot be regarded as definitely decided.¹ If the measurements can be carried into the extreme ultra-violet, most valuable evidence will doubtless result.

Returning to the rapid increase in various photo-activities with the change in the nature of the light, the matter will be clearer if the period is taken as the fundamental parameter rather than the wave-length, a proceeding which is amply justified by theoretical considerations. A scale plotted on this system is shown in Fig. 15; it serves to emphasize the obvious fact that for a given decrement in wave-length the corresponding increment in frequency is far greater on the border of the Schumann region than on the corresponding border of the

$$\frac{1}{\lambda} \times \text{constant}$$

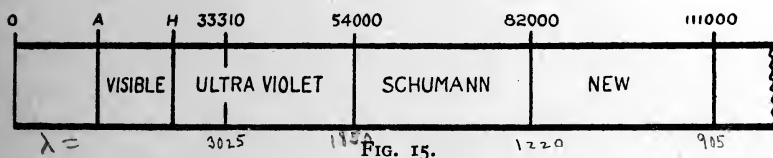

ultra-violet. An extension of the spectrum by a definite number of wave-lengths in the Schumann region is, therefore, more productive of important consequences than an equal extension in the ultra-violet, if these consequences are measured by phenomena whose magnitude depends on the period of light.

It only remains to consider the most recent work on the extension of the extreme ultra-violet by spectroscopic means and then to state very briefly the evidence which leads to the belief in ether vibrations of far shorter wave-lengths than can be studied by the methods of spectroscopy.

It has been shown that the spectrum was extended beyond the limit set by Schumann by removing all solid absorbing substances from the light path. The discharge tube communicated directly with the body of the spectroscope and both were filled with the gas under investigation. The spectrum was produced by a concave diffraction grating on speculum

¹ Pohl and Pringsheim, "Phil. Mag.," 26, p. 1018, 1913.

metal and was received on a photographic plate prepared according to the method of Schumann. The first attempt resulted in pushing the spectrum to λ 1030. Very recently the problem has been attacked again with the benefit of the technical knowledge of vacuum spectroscopy gained in more than eight years. The general method has remained unchanged, but great pains have been taken with the purity of the hydrogen employed, as well as with the prevention of leak in the spectroscope itself. Moreover, it has been found possible by a slight change in the nature of the vacuum tube to use a disruptive discharge without prohibitive fogging. The result has been a still further extension to λ 905. It is interesting to note by reference to Fig. 15 that this represents a greater extension in frequency with respect to the limit reached by Schumann than Schumann himself attained with respect to the limit probably reached by Stokes near λ 1850.

It may well be asked—to what is the present limit of the spectrum due? There are several causes which go to make up an answer to this question.

A much longer exposure might result in the discovery of new lines; unluckily, there are difficulties in the way of this seemingly simple step. For, as has been previously stated, with a windowless tube there is a great tendency for the discharge to spread into the receiver and cause fatal fogging of the plate. No plan has so far been devised which completely obviates this trouble, and up to the present the length of exposure has been limited by it. Besides this mechanical difficulty several other possible agents may exert an influence. Speculum metal may cease to reflect in the region near λ 900; that it reflects so well down to this point is surprising. The Schumann plates may cease to be sensitive. Small impurities in the hydrogen may exercise considerable absorption. Only experiments on metallic reflection, on the manufacture of plates, and on the purification of gases can answer these questions. There seems to be no insurmountable difficulty, however, to some further extension of the spectrum by purely spectroscopic investigation.

Experiments which attempt to show an extension of the

spectrum by indirect means are few in number and not perfectly conclusive. Wood¹ has observed that the spark produces a radiant emission which gives rise to luminescence in the nitrogen of the air. Fluorite 1 mm. thick cuts off the emission, but a very thin piece permits the emission to pass to a slight degree; this might lead to the conclusion that the effect is due to light which lies on the more refrangible side of the fluorite absorption band.

Lenard² has reported the existence of an emission from an aluminum spark which he detected by its ionising action. It penetrated 4 cm. of air and both quartz and fluorite. An experiment with a fluorite lens led him to ascribe to these rays a refractive index which would ordinarily belong to light between λ 1400 and λ 1370. That the rays were not of this wave-length is shown by their transmission through air and quartz which is known to be opaque to this part of the spectrum. Lenard explains the index obtained by ascribing the emission to the more refrangible side of the absorption fluorite. The discovery of the end of the absorption band of oxygen in the extreme ultra-violet lends some colour to this hypothesis, though the more refrangible limit of the absorption of the quartz and fluorite has not been discovered by spectroscopic means.

The statement that indirect experiments on the extension of the spectrum are not conclusive has obviously no reference to the extremely important work of Laue, Friedrich, Knipping, and the Braggs. They have established the fact that the X-rays are a form of ether vibrations whose wave-length is of the order of one Ångström unit, or about one nine hundredth that of the shortest wave-length obtained by the direct method. There is thus a gap of about nine hundred units between the shortest known wave-lengths which have been directly measured and the region of the X-rays. In this gap the behaviour of light toward solid and gaseous substances suffers a profound change. In the Schumann region the general opacity of matter to light is the most important

¹"Phil. Mag.," 20, p. 707, 1910; and *ibid.*, 27, p. 899, 1914.

²"Sitz. Heidelberg Akad. d. Wiss. Abhand.," p. 31, 1910.

characteristic; in the region of the X-rays, its transparency is a most striking phenomenon. The alteration in the behaviour of matter toward light is intimately connected with the vast increase in frequency. It will probably necessitate a considerable change in the methods of investigation if the gap in question is to be successfully bridged.

An example of the direction in which this change of methods is likely to take place is furnished by the recent work of Dember.¹ He has produced X-rays by the bombardment of photo-electrons whose speed was acquired in falling through a difference of potential of the order of twenty volts. He has estimated the wave-length of the rays by means of the Planck-Einstein formula, $eV = hn$. The value he obtained is 745 Ångström units, a figure strikingly near to the present limit of the spectrum from the concave grating. The result is very interesting and important, but the estimated wave-length cannot be accepted without reservation until the Planck-Einstein formula has been more fully established for a wider range of frequencies.

¹ "Verh. Deutsch. Phys. Gesell.," 15, pp. 560-565, 1913.

TABLES.

WAVE-LENGTHS IN VACUUM.

TABLE I.—SPECTRUM OF HYDROGEN.

Wave- Length.	Intensity.	Character.	Wave- Length.	Intensity.	Character.
1228.3	8		1279.8	5	
1230.1	8		1281.2	4	
1231.0	1		1282.6	1	
1232.1	5		1283.4	6	
1234.3	4		1284.5	5	double
1235.8	6		1286.9	5	double
1239.6	3		1288.1	4	
1241.5	2		1289.4	3	
1246.1	4		1290.4	5	
1247.2	4		1291.3	2	
1248.0	2		1293.6	6	double
1249.8	3		1295.7	2	double
1251.2	3		1297.4	5	
1253.2	6		1299.5	1	
1253.9	5		1300.0	3	double
1255.5	4		1302.5	2	double
1257.1	4		1307.5	2	
1258.2	4		1311.1	2	
1259.9	4		1312.9	2	
1261.9	8		1314.7	1	
1264.0	1		1315.6	1	double
1264.6	5		1319.2	4	
1265.8	4		1323.4	5	
1267.3	1		1325.0	5	double
1268.3	1		1327.1	3	
1269.1	3		1327.5	2	
1269.9	1		1329.3	1	
1270.7	4		1331.3	6	
1271.5	4		1333.9	8	double
1272.0	1		1335.3	2	
1273.3	3		1336.1	8	double
1274.2	1		1337.6	6	
1275.0	3		1338.7	7	double
1276.1	1		1340.9	1	double
1277.1	6	double	1342.4	8	
1279.0	1		1343.6	1	

TABLE I.—SPECTRUM OF HYDROGEN (*continued*).

Wave- Length.	Intensity.	Character.	Wave- Length.	Intensity.	Character.
1345.4	8	double	1411.8	1	
1347.2	9	double	1413.0	8	
1349.1	2		1414.9	2	
1350.2	3		1416.4	3	
1350.8	3		1419.5	2	
1352.5	8		1420.3	3	
1353.6	8		1426.8	3	
1355.5	7		1427.8	7	double
1357.3	6		1429.0	3	
1358.2	4		1430.1	7	
1359.2	5		1431.1	3	
1360.1	5		1433.0	8	double
1362.4	1		1434.3	3	
1363.4	8		1435.2	4	
1364.3	3		1436.3	7	double
1365.8	5		1438.0	4	
1366.5	1		1439.1	1	
1367.6	3	double	1441.0	8	
1368.0	3		1442.8	1	
1369.1	1	double	1443.6	7	
1370.4	2		1445.2	4	
1371.3	6		1446.2	6	
1372.1	1		1447.4	2	?
1372.9	3		1449.2	2	
1374.0	1		1450.3	5	
1374.5	2		1451.0	1	
1375.5	1		1452.0	3	
1376.1	1		1452.5	1	
1377.2	6	double	1454.3	1	
1378.0	1	double	1455.1	7	double
1380.2	5		1456.3	4	
1380.8	1		1457.4	6	
1382.9	1		1458.4	6	
1383.0	1		1460.1	5	double
1384.2	1		1461.0	4	
1385.6	2		1462.0	3	
1386.3	3		1462.9	4	
1387.7	4		1463.9	8	
1390.0	1	double	1465.2	3	
1391.2	1		1467.2	6	double
1393.2	3		1468.6	6	
1394.0	7	double	1471.0	3	
1395.2	2		1472.5	3	
1396.4	7		1473.9	5	
1397.5	6		1474.9	4	
1398.0	1		1476.4	4	
1399.0	7		1477.3	3	
1400.6	1		1478.9	2	
1402.0	4		1479.7	4	
1402.8	8		1480.4	4	
1404.3	5		1481.7	5	
1405.5	2		1482.1	1	
1407.3	7		1483.7	3	
1408.6	3		1486.1	1	
1410.5	8	triple	1486.9	9	

TABLE I.—SPECTRUM OF HYDROGEN (*continued*).

Wave-Length.	Intensity.	Character.	Wave-Length.	Intensity.	Character.
1487·8	1		1563·0	1	
1489·3	6		1564·0	1	
1489·9	3		1565·1	3	double
1491·9	7		1567·1	5	double
1492·7	1		1569·2	6	
1494·1	3		1569·7	1	
1495·5	10	double	1571·3	1	
1499·8	8		1571·7	7	
1502·2	2		1574·3	5	
1503·9	1		1577·2	8	
1505·0	8		1579·2	4	
1505·9	1		1581·0	7	double
1506·6	1		1584·1	7	
1511·5	8		1585·7	7	double
1513·6	7		1587·6	3	
1515·0	6		1589·0	8	triple
1516·4	5		1590·9	4	
1517·5	6	double	1591·5	8	
1519·0	6		1593·6	7	
1520·1	5		1595·2	1	
1521·7	2		1596·2	10	
1522·5	2		1599·4	6	
1523·4	8		1602·0	8	
1525·4	5		1602·8	1	
1526·6	2		1603·8	1	
1527·5	4		1604·6	6	
1529·7	3		1605·3	5	
1530·9	6		1606·3	5	
1532·1	6		1607·7	10	
1533·2	6		1608·2	6	
1535·0	6	double	1608·6	10	
1536·7	1		1609·2	3	
1537·5	7	double	1610·1	2	triple
1539·2	5		1610·5	7	
1539·9	2		1611·2	1	
1540·6	2		1611·8	3	
1541·6	7		1612·5	1	
1543·9	2		1613·3	7	
1544·7	8		1614·3	4	
1545·5	2	double	1615·0	3	
1546·4	6		1616·7	6	
1547·4	7	double	1617·9	1	
1548·3	1		1619·9	2	double
1549·9	7	double	1621·1	7	double
1550·6	7	double	1622·1	3	
1551·5	2		1623·2	2	
1553·3	10		1623·8	7	
1554·9	3		1625·8	4	
1555·6	1		1627·6	1	
1556·4	2		1628·5	8	
1557·4	1		1631·7	2	
1558·7	1		1633·7	6	
1560·0	1		1634·1	4	
1561·1	2		1635·3	3	
1562·2	4		1636·5	7	

TABLE I.—SPECTRUM OF HYDROGEN (*continued*).

Wave-Length.	Intensity.	Character.	Wave-Length.	Intensity.	Character.
1638·2	4		1647·8	1	
1639·1	5		1651·8	1	
1639·7	1		1654·2	2	
1640·5	6		1662·9	1	
1641·6	5		1667·4	2	
1643·0	5		1670·2	1	
1644·6	7		1671·6	2	
1645·7	2		1672·4	2	
1646·0	1		1674·6	1	

LINES OF UNCERTAIN ORIGIN.

PROBABLY DUE TO HYDROGEN.

Wave-Length.	Intensity.	Character.	Wave-Length.	Intensity.	Character.
1030·8	1		1176·2	5	double
1034·2	2		1178·5	3	double
1045·2	4		1180·8	7	
1047·5	5		1182·7	4	
1062·1	1		1185·0	2	
1065·6	3		1189·0	7	double
1070·0	1		1198·6	2	
1080·0	1		1200·2	2	
1082·1	1		1201·8	3	
1094·9	2		1202·8	1	
1098·0	2		1205·2	6	
1100·0	3		1206·9	6	
1102·2	4		1207·8	2	
1104·8	6		1209·2	6	
1107·5	6		1209·7	1	
1110·5	3		1210·8	2	
1119·4	4		1211·7	3	
1145·5	8	double	1215·0	2	
1148·8	2		1216·0	8	
1151·2	2		1217·6	3	
1160·9	10	double	1219·1	1	
1164·0	6		1221·5	1	
1166·5	6		1223·7	3	
1169·2	1		1225·2	1	
1172·6	1		1225·9	7	
1174·9	1		1227·5	1	

TABLE II.—NITROGEN.

Band Spectrum.				Line Spectrum.	
λ .	I.	λ .	I.	λ .	I.
1383.7	3	1672.3	3	1492.8}	6
1393.5	2	1687.5	2	1494.8}	5
1416.1	3	1736.9	2		
1431.6	2	1752.9	3	1742.7} Si ?	7
1464.8	4	1768.5	3	1745.3}	6
1471.1	1	1804.7 ?	2		
1501.1	3	1821.1	4		
1515.4	2	1837.6	5		
1530.6	2	1854.0	3		
1554.4	5	1870.9	2		
1611.8 ?	4				

TABLE III.—CARBON MON-OXIDE.

λ .	I.	N.	λ .	I.	N.
1335 ^o 0	1	74,906	1615 ^o 1	2	61,916
1339 ^o 0	1	74,683	1623 ^o 4	1	61,599
1343 ^o 0	1	74,460	1629 ^o 6	3	61,365
1353 ^o 6	1	73,877	1630 ^o 3	6	61,338
1356 ^o 1	2	73,741	1648 ^o 2	5	60,672
1361 ^o 3	2	73,459	1653 ^o 3	4	60,485
1368 ^o 0	1	73,099	1666 ^o 7	1	59,999
1371 ^o 8	2	72,897	1669 ^o 9	6	59,884
1374 ^o 1	2	72,775	1685 ^o 3	1	59,337
1378 ^o 1	2	72,564	1688 ^o 5	1	59,224
1384 ^o 4	1	72,233	1698 ^o 8	1	58,865
1386 ^o 4	1	72,129	1705 ^o 3	6	58,641
1392 ^o 2	1	71,829	1712 ^o 2	7	58,404
1395 ^o 7	2	71,649	1723 ^o 9	6	58,008
1401 ^o 1	2	71,372	1729 ^o 5	8 <i>d</i>	57,820
1404 ^o 0	1	71,225	1743 ^o 5	3	57,356
1405 ^o 5	1	71,149	1747 ^o 3	7	57,231
1409 ^o 0	2	70,972	1774 ^o 9	8 <i>d</i>	56,341
1411 ^o 4	1	70,852	1785 ^o 1	6	56,019
1414 ^o 0	1	70,721	1792 ^o 6	10 <i>d</i>	55,785
1419 ^o 0	2	70,472	1801 ^o 9	2	55,497
1426 ^o 1	3	70,121	1804 ^o 9	8	55,405
1435 ^o 6	2	69,657	1811 ^o 0	10 <i>d</i>	55,218
1438 ^o 7	1	69,507	1825 ^o 7	7	54,774
1443 ^o 7	1	69,266	1830 ^o 1	9	54,042
1447 ^o 0	1	69,109	1837 ^o 2	1	54,431
1452 ^o 4	3	68,852	1841 ^o 3	8	54,399
1463 ^o 7	3	68,320	1846 ^o 7	2	54,151
1473 ^o 0	1	67,889	1849 ^o 4	4	54,072
1475 ^o 4	1	67,778	1859 ^o 6	10 <i>d</i>	53,775
1478 ^o 0	2	67,659	1870 ^o 3	3	53,467
1480 ^o 9	2	67,527	1878 ^o 5	10 <i>d</i>	53,234
1488 ^o 0	2	67,204	1891 ^o 2	6	52,876
1493 ^o 8	3	66,943	1898 ^o 0	10	52,687
1497 ^o 8	3	66,765	1914 ^o 0	1	52,247
1506 ^o 8	2	66,366	1918 ^o 2	7	52,132
1510 ^o 7	2	66,194	1931 ^o 5	6	51,773
1515 ^o 7	3	65,976	1933 ^o 6	2	51,717
1520 ^o 4	1	65,772	1950 ^o 4	4	51,272
1526 ^o 0	2	65,531	1951 ^o 7	5	51,237
1527 ^o 6	3	65,462	1953 ^o 0	5	51,203
1534 ^o 2	2	65,181	1970 ^o 1	8	50,759
1542 ^o 2	5	64,842	1991 ^o 0	1	50,226
1545 ^o 1	3	64,721	2007 ^o 2	5	49,821
1559 ^o 3	5	64,131	2012 ^o 6	8	49,687
1576 ^o 5	4	63,432	2026 ^o 4	7	49,349
1596 ^o 1	1	62,653	2031 ^o 7	1	49,220
1597 ^o 4	3	62,602	2035 ^o 1	4	49,138
1603 ^o 3	1	62,371	2047 ^o 0	8	48,852
1611 ^o 7	3	62,046	2068 ^o 4	8	48,347

TABLE IV.—ARGON.

“BLUE” SPECTRUM.

λ .	I.	λ .	I.	λ .	I.	λ .	I.
1333.7	5	1604.2	4	1827.6	6	1846.9	6
1334.5	7	1607.0	3	1830.6 ¹	10	1850.2	4
1335.8	7	1611.0	4	1831.4 ¹	9	1855.7	9
1460.1	5	1614.8	4	1834.5 ²	2	1865.9	8
1463.3	3	1669.7	7	1835.5 ²	2	1868.7	8
1465.6	4	1673.5	7	1836.3	9	1873.2	10
1467.9	2	1675.6	7	1838.1 ²	2	1877.7	8
1589.5	4	1788.1	5	1839.2	9	1879.7	8
1600.7	5	1807.5	4	1842.3 ²	1	1886.1	7
1602.6	2	1820.0	7	1843.1	9		

TABLE V.—ALUMINUM.

λ .	I.	ν/λ .	λ Handke.	Diff.	λ .	I.	ν/λ .	λ Handke.	Diff.
1238.8 ³	I	80723	—	—	1750.0	3	57143	1750.4	0.4
1264.5 ³	I	79083	—	—	1751.7	2	57087	1752.1	.4
1275.0 ³	3	78431	—	—	1760.0	8	56818	1760.4	.4
1276.4 ³	2	78345	—	—	1761.9	8	56757	1762.4	.5
1310.8 ³	6	76290	—	—	1763.8	10	56695	1764.2	.4
1319.4 ³	6	75792	—	—	1765.7	8	56635	1766.0	.3
1326.6 ³	I	75380	—	—	—	—	—	1766.9	—
1343.4 ³	2	74438	—	—	1767.6	8	56574	1768.0	.4
1352.8	I	73921	—	—	—	—	—	1769.6	—
1379.5	3	72490	—	—	—	—	—	1772.9	—
1383.9	5	72259	—	—	1773.8	2	56376	1773.8	.0
1540.1	I	64931	—	—	—	—	—	1774.9	—
1605.6	8	62282	1605.9	0.3	1776.9	4	56278	1777.1	.2
1611.8	8	62042	1612.1	.3	—	—	—	1777.8	—
1670.6	10	59859	1671.0	.4	—	—	—	1792.1	—
—	—	—	1676.1	—	1818.5	3	54990	1819.0	.5
1718.3	I	58197	1719.1	.8	—	—	—	1819.6	—
1719.3	9	58163	1720.0	.7	—	—	—	1820.6	—
1721.2	9	58099	1722.0	.8	—	—	—	1833.2	—
1725.0	10	57971	1725.3	.3	—	—	—	1836.8	—
—	—	—	1741.1	—	1854.7	50	—	1854.7	—
1742.7	N.	57382	1743.6	.9	1858.2	10	—	1858.2	—
1745.3		57297	1746.3	1.0	1862.8	50	—	1862.8	—
1747.7	I	57218	1748.3	.6	—	—	—	—	—

¹ Present in the “white” spectrum.

² Origin uncertain.

³ Origin in doubt.

TABLE VI.—CALCIUM.

λ .	I.	$1/\lambda$.	$\Delta 1/\lambda$.	λ .	I.	$1/\lambda$.	$\Delta 1/\lambda$.
1246.2	1	80244	—	1553.5	7	64370	66
1254.3	2	79726	—	1555.1	8	64304	
1260.2	1	79352	—	1561.2	2 ?	64053	227
1264.5	2	79083	—	1674.1	1	59733	
1268.2	2	78852	—	1680.5	2	59506	
1276.4	3	78345	—	1692.4	1	59087	
1369.1	3	73040	80	1608.9	2	58861	226
1370.6	3	72960		1807.8	7	55316	220
1393.6	5	71761	—	1815.0	8	55096	
1402.7	4	71291	—	1838.0	9	54406	65
1433.1	5	69778	58	1840.2	10	54341	
1434.3	6	69720		1843.8	6	54236	
1526.7	2	65501	—	1851.3	7	54016	
1533.4	2	65214	—	1870.4	3	53464	—
1546.0	?	64683	—	1872.5	3	53404	—

TABLE VII.—STRONTIUM.

λ .	I.	$1/\lambda$.	$\Delta 1/\lambda$.	λ .	I.	$1/\lambda$.	$\Delta 1/\lambda$.
1532.3 ?	1	65261	—	1769.8	8	56503	286
1537.9 ?	1	65024	—	1778.8	9	56217	
1560.8 ?	1	64070	—	1820.0	1	54945	803
1613.3	4	61985	283	1847.0	3	54142	
1620.7	5	61702					

TABLE VIII.—BARIUM.

λ .	I.	$1/\lambda$.	$\Delta 1/\lambda$.	λ .	I.	$1/\lambda$.	$\Delta 1/\lambda$.
1331.1	2	75126	—	1572.9	2	63577	—
1361.0	2	73475	—	1592.9	1	62778	—
1414.8	3	70681	—	1674.5	4	59719	—
1417.1	2	70567	—	1677.9	3	59598	577
1482.0	1	67476	—	1694.3	6	59021	
1485.0	1	67340	—	1786.6	1	55972	—
1487.0	2	67249	—	1849.5	2	54068	569
1503.9	4	66494	—	1869.2	5	53499	
1554.5	3	64329	—				

TABLE IX.—SPARK.

MAGNESIUM IN HYDROGEN. *Lyman.*

λ .	I.	$1/\lambda$.	$\Delta 1/\lambda$.	λ .	I.	$1/\lambda$.	$\Delta 1/\lambda$.
1735 ^o 1737 ⁸	6 7	57637 } 57544 }	93	1750 ⁹ 1753 ⁶ 1828 ¹	5 6 1	57113 } 57025 } 54702 }	88 —

MAGNESIUM IN AIR. *Handke.*

λ .	I.	λ .	I.
1734 ^o	1	1753 ^o	3
1736 ³	2	1839 ⁶	3
1741 ⁴	5	1855 ⁹	5
1744 ¹	5	1804 ¹	4
1746 ⁷	1	1886 ⁸	5
1750 ^o	1	1930 ⁹	6
1750 ⁷	2		

THE SPECTROSCOPY OF

TABLE X.—MERCURY.

Spark.			Arc.		
Lyman.			Lyman.		Wolff.
λ .	I.	$1/\lambda$.	λ .	I.	
1269.7	5	78758	—	—	—
1277.1	4	78302	—	—	—
1280.7	4	78082	—	—	—
1305.6	3 ?	76593	—	—	—
1307.9	2	76458	—	—	—
1321.4	3	75677	—	—	—
1323.2	4	75574	—	—	—
1326.4	4	75392	—	—	—
1330.8	7 Ba ?	75143	—	—	—
1335.4	5	74884	—	—	—
1350.4	3	74052	—	—	—
1361.0	4 Ba ?	73475	—	—	—
1378.0	1	72569	—	—	—
1379.0	1	72516	—	—	—
1400.4	2	71408	—	—	—
—	—	71301	1402.5	6	1402.72
1404.3	1	71209	—	—	—
1414.4	4	70701	—	—	—
1416.0	4 Ba ?	70576	—	—	—
—	—	69657	—	2	1435.63
1481.6	1	67494	—	—	—
1495.0	3	66889	—	—	—
—	—	65850	1518.6	3	—
1527.4	5	65470	—	—	—
1540.5	2	64914	—	—	—
1548.4	1 ?	64583	—	—	—
1550.8	2 ?	64483	—	—	—
1561.0	1 ?	64061	—	—	—
1568.0	2	63775	—	—	—
1570.3	1	63682	—	—	—
1592.9	8 ?	62778	—	—	—
1599.4	7	62523	—	—	—
1641.5	1	60919	—	—	—
1647.4	9	60702	—	—	—
1649.8	10 br	60613	1649.8	8	1650.17
1652.5	3	60514	—	—	—
1654.7	5	60434	—	—	—
1656.9	3 ?	60353	—	—	—
1662.6	7	60146	—	—	—
1670.1	1	59876	—	—	—
1671.0	7	59844	—	—	—
1672.5	4	59790	—	5	1672.75
—	—	59683	—	4	1675.55
1677.9	10	59598	—	—	—
1681.6	1	59467	—	—	—
1692.7	2	59077	—	—	—
1695.0	2	58997	—	—	—
1716.6	1	58254	—	—	—

TABLE X.—MERCURY (continued).

Spark.			Arc.		
Lyman.			Lyman.		Woff.
λ .	I.	$1/\lambda$.	λ .	I.	
1718.1	2	58204	—	—	—
1720.7	2	58116	—	—	—
1724.2	1	57997	—	—	—
1726.8	1	57911	—	—	—
1735.8	1	57610	—	—	—
1738.3	8	57527	—	—	—
1740.2	6	57464	—	—	—
1741.0	2	57438	—	—	—
1742.7	2	57382	—	—	—
1745.2	1	57300	—	—	—
1751.5	1	57094	—	—	—
1756.0	2	56947	—	—	—
1759.7	6	56828	—	—	—
1764.0	1	56689	—	—	—
1770.1	1	56494	—	—	—
—	—	56341	1774.9	5	1774.95
1775.2	3	56331	—	—	—
1780.0	1	56179	—	—	—
1787.7	1	55938	—	—	—
1792.7	5	55781	—	—	—
1796.2	7	55673	—	—	—
1798.7	9	55595	—	—	—
1800.7	1	55534	—	—	—
1803.9	3	55435	—	—	—
1806.5	2	55355	—	—	—
1808.3	2	55300	—	—	—
—	—	55248	1810	3 band	—
1816.1	1	55063	—	—	—
1820.8	10	54921	—	—	—
1823.8	3	54830	—	—	—
1826.2	4	54758	—	—	—
1832.7	6	54564	1832.6	4	1832.6
1837.1	1	54433	—	—	—
1840.8	7	54324	—	—	—
1849.0	5	54083	—	—	—
1849.6	5 reversed	54065	1849.6	> 100	1849.57
1850.3	3	54045	—	—	—
1853.4	4	53954	—	—	—
1859.5	2 br	53778	—	—	—
1861.0	1	53734	—	—	—
1862.3	1	53697	—	—	—
1865.1	1	53616	—	—	—
1869.4	10 br	53493	—	—	—
1875.7	6	53313	—	—	—

I.	Wolff. Arc.	Handke. Spark.	Stark. Arc.	Lehmann and Straubel. Vac. Tube.	Huff. Vac. Tube.
10	1942'52	1942'I	1942'37	1942'3	—
4	1973'2	1972'6	1972'99	1973'73	—
5	1973'98				—
1	1988'07	—	—	1987'93	—
2	2002'9	2004'I	2002'87	—	2002'23
5	2028'3	—	2028'00	2028'34	—
8	2053'7	—	2054'4I	2055'14	—

TABLE XI.—SILVER.

SPARK. *Handke.*

λ .	I.	λ .	I.	λ .	I.
1674'5	2	1766'3	2	1858'3	4
1675'4	1	1768'6	6	1860'0	5
1678'7	2	1771'8	6	1862'9	5
1681'4	4	1778'9	3	1866'1	7
1694'0	6	1780'5	1	1867'1	7
1706'1	3	1781'6	1	1871'8	5
1707'6	2	1782'9	1	1872'5	6
1709'5	2	1784'2	2	1874'2	3
1713'0	1	1785'7	1	1877'6	1
1714'3	1	1793'9	5	1879'0	6
1718'1	3	1796'9	1	1881'2	1
1719'1	3	1797'7	1	1884'3	2
1722'4	5	1802'1	6	1888'1	6
1727'2	3	1805'1	2	1892'8	4
1728'7	4	1808'0	5	1895'6	4
1736'9	1	1808'9	2	1897'4	2
1740'7	1	1816'4	6	1898'8	1
1743'1	5	1818'8	1	1907'1	4
1745'6	4	1821'0	1	1911'9	4
1747'6	3	1822'0	4	1915'7	8
1748'1	1	1823'5	1	1924'2	5
1751'3	6	1826'5	4	1932'1	6
1751'7	3	1828'6	5	1936'4	1
1754'9	2	1831'8	4	1942'5	2
1755'7	2	1834'0	3	1944'6	3
1757'9	3	1835'6	3	1945'7	3
1758'7	2	1838'1	4	1947'8	4
1760'7	4	1839'5	5	1952'6	3
1761'8	1	1846'7	5	1957'2	7
1762'6	2	1849'4	5	1959'2	1
1763'1	3	1853'4	4	1960'5	1
		1855'9	4	1966'6	3

TABLE XII.—GOLD.

SPARK.

Handke.	I.	Handke.	I.	Handke.	I.	Eder and Valenta.
1623·2	1	1752·0	2	1858·5	3	—
1630·0	1	1756·0	4	1860·2	4	—
1638·3	1	1757·1	4	1862·7	5	—
1639·2	2	1762·3	1	1866·2	2	—
1644·2	1	1763·0	5	1872·6	6	1872·38
1646·0	2	1764·2	1	1875·1	1	—
1646·8	1	1768·0	4	1880·3	4	1880·34
1659·2	2	1773·0	1	1881·4	2	—
1664·6	3	1775·4	1	1887·6	6	1887·47
1665·6	1	1776·0	5	1891·1	6	1890·87
1666·0	1	1777·1	2	1900·0	2	—
1672·6	2	1781·5	2	1900·9	2	—
1673·2	5	1784·2	8	1905·6	5	1905·04
1675·7	1	1787·2	4	1908·2	1	—
1693·5	6	1791·2	3	1910·0	3	—
1696·5	1	1794·8	7	1911·5	1	—
1698·2	3	1802·0	7	1918·6	2	1918·67
1699·5	2	1803·1	3	1920·0	6	1920·02
1700·0	3	1806·6	4	1922·4	7	1922·01
1701·6	2	1808·7	1	1926·0	7	1925·82
1707·0	2	1811·0	1	1926·6	1	—
1710·6	3	1813·3	2	1927·6	1	—
1713·0	1	1817·0	2	1929·9	2	—
1715·1	3	1819·1	3	1932·4	3	1932·37
1716·1	1	1822·2	5	1935·1	2	—
1717·2	3	1827·1	6	1936·0	3	1935·76
1718·0	3	1829·1	1	1938·6	3	—
1719·5	4	1830·9	2	1939·6	1	—
1725·5	5	1834·2	2	1942·9	2	—
1726·9	4	1835·0	3	1944·7	3	1944·99
1730·2	1	1837·1	3	1948·1	3	1947·05
1732·9	2	1840·6	3	1948·9	3	1949·12
1736·3	2	1842·1	1	1952·4	4	1952·23
1738·2	3	1845·9	4	1956·2	3	1956·28
1739·9	6	1847·3	1	1956·6	2	—
1742·2	5	1849·8	3	1958·1	2	—
1745·0	3	1851·0	4	1958·8	2	—
1746·0	3	1852·6	4	1973·3	2	(1973·30)?
1748·5	2	1853·3	4			
1749·8	4	1857·3	4			

THE SPECTROSCOPY OF

TABLE XIII.—CADMIUM.

ARC. *Wolf*.

λ .	I.	λ .	I.
1423'23	1	1669'29	10
1440'18	3	1682'12	1
1469'39	6	1688'58	2
1526'85	8	1710'51	3
1537'83	1	1942'29	6
1571'40	1	1993'07	1
1647'78	2		

TABLE XIV.—COPPER.

SPARK. *Handke*.

λ .	I.	λ .	I.	λ .	I.
1594'2	1	1686'6	8	1754'5	6
1600'0	1	1688'5	7	1760'0	3
1602'9	1	1692'3	7	1760'6	4
1605'4	1	1695'8	1	1762'0	5
1606'1	1	1700'4	6	1765'5	3
1607'0	1	1701'8	8	1769'1	8
1608'8	1	1702'6	8	1771'6	4
1615'5	3	1703'7	1	1773'0	3
1625'6	4	1705'0	6	1774'4	2
1627'3	4	1707'0	1	1775'7	6
1638'4	4	1708'5	7	1779'3	5
1641'8	9	1710'6	6	1783'7	7
1651'9	7	1713'0	2	1787'4	4
1653'1	2	1715'8	2	1792'1	3
1654'1	7	1717'7	7	1798'2	5
1657'8	5	1721'9	8	1803'0	1
1660'2	3	1724'2	4	1805'9	2
1669'0	1	1725'9	3	1817'3	1
1669'8	8	1727'8	7	1819'1	1
1671'6	8	1729'7	1	1821'1	1
1674'5	7	1730'5	1	1823'0	1
1675'7	1	1732'4	4	1826'1	8
1676'4	2	1737'6	7	1834'9	3
1677'3	5	1739'0	7	1836'3	1
1679'0	8	1741'0	8	1840'1	8
1681'2	7	1742'3	9	1848'9	3
1681'9	2	1744'7	9	1850'9	2
1682'4	3	1747'1	6	1857'6	4
1684'3	7	1749'9	9	1867'6	7
1686'4	6	1751'4	9	1882'1	3
				1885'0	5

TABLE XV.—TIN.

SPARK. *Handke.*

λ.	I.	λ.	I.	λ.	I.
1700·1	3	1812·0	8	1900·4	10
1719·1	2	1819·6	1	1927·1	1
1741·1	1	1825·9	2	1931·7	2
1743·6	5	1830·0	1	1942·7	6
1746·3	4	1832·0	6	1952·5	1
1748·3	3	1854·9	1	1955·6	2
1752·1	4	1863·1	1	1961·2	1
1758·2	7	1866·0	1	1971·9	1
1770·0	2	1879·2	3	1979·8	1
		1885·5	2	1984·7	1

TABLE XVI.—ZINC.

SPARK.

Handke. λ.	I.	Handke. λ.	I.	Handke. λ.	I.	Eder and Valenta. λ.
1632·9	1	1762·9	2	1864·6	5	—
1642·0	2	1768·0	7	1866·9	2	—
1647·0	4	1774·7	1	1868·5	1	—
1653·2	3	1790·4	1	1872·9	4	—
1673·6	7	1791·3	3	1886·1	4	—
1689·0	5	1794·0	1	1893·2	1	—
1695·9	1	1795·5	1	1895·1	1	—
1707·0	7	1797·0	1	1902·6	2	—
1719·1	4	1798·0	3	1915·9	1	—
1736·5	3	1811·2	7	1919·5	3	1919·0
1741·1	1	1817·1	2	1931·2	2	—
1743·6	10	1825·4	3	1946·5	1	—
1746·3	8	1829·9	2	1953·1	2	1952·9
1748·3	4	1832·0	2	1955·5	1	—
1750·4	7	1834·0	7	1965·3	1	—
1752·1	5	1836·6	2	1969·9	2	1969·3
1754·1	2	1839·8	6	1982·7	3	1982·1
				1987·3	1	1986·9

ARC.

Wolff. λ.	I.	Wolff. λ.	I.
1376·87	2	1486·20	5
1404·19	4	1589·76	10
1450·82	1	1601·09	4
1457·56	8	1632·11	4
1474·67	3	1649·87	5
1476·01	2		

TABLE XVII.—LINES OF UNCERTAIN ORIGIN.¹ *Lyman.*

λ .	I.	$1/\lambda$.	λ .	I.	$1/\lambda$.
1302·0	4	76805	1550·8	5	64483
1304·8	3	76640	1561·2	3	64053
1305·8	1	76581	1649·9	3	60609
1334·6	2	74929	1656·8	4	60357
1335·7	3	74867	1657·8	1	60321
1548·2	6	64591			

¹ Present in metallic spark spectra in hydrogen, helium, or air.

BIBLIOGRAPHY.¹

- Abbot, C. G. Annals of the Astrophysical Observatory of the Smithsonian, III, 1913, Tables 45, 46, 47; Science, 39, 335, 1914.
- Bloch, L. & E. Comptes Rendus, 158, p. 1161, 1914.
- Buisson, H. Comptes Rendus, 156, p. 389, 1913.
Journal d. Physique, 3, p. 196, 1913.
- Coblentz, W. W. Bull. Bureau of Standards, V, 9, No. 1, p. 7.
- Cornu, A. Comptes Rendus, 88, pp. 1101, 1285, 1879; 89, p. 808, 1879; 90, p. 940, 1880; 111, p. 941, 1890.
- Cuthbertson, C. & M. Proc. Roy. Soc., 83, p. 151, 1910.
- d'Albe, E. E. F. " " " A., V, 89, No. 608, p. 75.
- Dember, H. Abhand. d. Natwiss. Gesell., "Isis" in Dresden, 1912, Heft 2, p. 1.
Verh. Deutsch. Phy. Gesell., 15, p. 560, 1913.
- Deslandres, H. Comptes Rendus, 106, p. 842, 1888.
- Dewar, Sir J. Phil. Mag., 26, p. 286, 1888.
- Difregger, F. P. Ann. d. Phy., 41, p. 1012, 1913.
- Dufour, A. Journal d. Physique, p. 258, 1909.
Ann. Chim. Phys., p. 416, 1906.
- Einstein, A. Ann. d. Phy., 20, p. 199, 1905.
- Elster, J. Physik. Zeitsch., 15, p. 1, 1914; 14, p. 741, 1913.
- Fabry, Ch. Journal d. Physique, 3, p. 196, 1913.
Comptes Rendus, 156, p. 389, 1913.
- Fowle, F. E. Astrophysical Jour., 38, p. 392, 1913.
- Fowler, A. Roy. Astron. Soc. Monthly Notices, LXXIII, No. 2, 1912.
- Fritsch, C. Physik. Zeitsch., 8, p. 518, 1907.
- Fulcher, G. S. Astrophysical Jour., 37, 60, 1913.
- Geiger, L. Ann. d. Phy., 37, p. 68, 1912.
- Geitel, H. Physik. Zeitsch., 14, p. 741, 1913.
" " 15, p. 1, 1914.
- Hagen, E. Ann. d. Phy., 8, p. 2, 1902.
- Hallwachs, W. Wied. Ann., 33, p. 301, 1888.
- Handke, F. Inaug. Diss. Berlin, Aug. 1909.
- Hartley, W. N. Nature, 39, p. 474, 1889.
- Henri, Victor Journal d. Physique, III, p. 305, 1913.
- Herchfinkel, Comptes Rendus, 149, p. 395, 1909.
- Hughes, A. L. Phil. Mag., 25, p. 679, 1913.
" " 21, p. 393, 1911.
- Phil. Trans. Roy. Soc. Lond., 212, p. 205, 1912.

¹ The citations are in the order in which they occur in the text.

- Ives, H. E. *Astrophysical Jour.*, 39, p. 428, 1914.
 Kayser, H. *Ber. Berlin Akad.*, III, 5, 1892.
Handbuch d. Spek. III, p. 45.
 " " " p. 377.
 " " " p. 380.
 " " " p. 337.
 " " " p. 353.
 " " " p. 361.
 " " " p. 338.
 " " IV, p. 477.
 " " " p. 484.
 " " VI, pp. 212-18.
 " " V, p. 834.
 " " " p. 518.
 " " " p. 74.
 " " III, p. 339.
- King, L. V. *Phil. Trans. Roy. Soc. Lond., A.*, 212, p. 375, 1913.
 Königsberger, J. *Zeitsch. f. Instru. Kunde.*, 21, pp. 59, 129, 1901.
 Kreuzler, H. *Ann. d. Phys.*, 6, pp. 412, 418, 420, 1901.
 Krüger, F. *Physik. Zeitsch.*, 13, p. 729, 1912.
 Krüss, H. *Zeitsch. f. Instru. Kunde.*, 23, pp. 197-229, 1903.
 Ladd, Miss *Astrophysical Jour.*, 14, p. 114, 1901.
 Ladenburg, E. *Verhandl. d. Physik. Gesell.*, 4, p. 125, 1906.
 Larmor, Sir J. *Astrophysical Jour.* 26, p. 120, 1907.
 Lehmann, E. *Ber. Berlin Akad.*, 8, p. 268, 1909.
Verhandl. d. Physik. Gesell., 4, p. 125, 1906.
 Lenard, P. *Sitz. Heidelberg Akad. d. Wiss. Abhand.*, 28, 31, 1910.
 Liveing, G. D. *Phil. Mag.*, 26, p. 286, 1888.
 Lyman, T. *Astrophysical Jour.*, 28, 52, 1908.
 " " 25, 45, 1907.
 " " 27, 98, 1898.
 " " 23, 181, 1906.
 " " 35, 341, 1912.
 " " 38, 282, 1913.
 " " 33, 98, 1911.
- Memoirs Amer. Acad.*, XIII, No. III, Plates III, IV, V.
Physik. Zeitsch., 13, p. 583, 1912.
Nature, 84, p. 71, 1910.
British Asso. Report, p. 134, 1909.
Proc. Amer. Acad., 45, p. 315, 1910.
Ann. d. Phys., 6, p. 619, 1901; Kayser, IV, p. 477.
 " " 31, p. 1017, 1910.
 " " 12, p. 849, 1903.
S.A. Vierteljahrsh. Astron. Ges., 48, p. 210, 1913.
Sitz. Ber. Berlin Akad., 8, p. 268, 1909.
Ann. d. Phys., 10, p. 581, 1903.
Physik. Zeitsch., 13, p. 729, 1912.
Proc. Manchester Phil. Soc., 49, p. 1, 1904.
Roy. Astron. Soc. Monthly Notices, Mar., 1914.
- Martens, F. F.
 Meier, W.
 Meyer, E.
 Miethé, A.
 Minor, R. S.
 Moeller, M.
 Morris-Airey, H.
 Nicholson, M. A.

- Nutting, P. G. Outlines of Applied Optics, chap. ix.
Phy. Rev., 16, p. 129, 1903.
- Palmer, F. " " 32, p. 1, 1911.
- Paschen, F. Ann. d. Phys., 35, p. 360, 1911; 40, p. 602, 1913.
- Pflüger, A. Physik. Zeitsch., 4, p. 429, 1903.
" " 5, p. 215, 1904.
Ann. d. Phys., V. 13, p. 890, 1904.
- Pohl, R. Phil. Mag., 26, p. 1018, 1913.
- Pring, J. N. Proc. Roy. Soc. A. 90, A. 617, p. 204.
- Pringsheim, P. Phil. Mag., 26, p. 1018, 1913.
- Ramsauer, C. Sitz. Heidelberg Akad. d. Wiss. Abhand., 31, 1910.
- Richardson, O. W. Phil. Mag., 26, p. 549, 1913.
- Ritz, W. Ann. d. Phys., 25, p. 667, 1908.
Physik. Zeitsch., 9, p. 528, 1908.
- Rosenberg, H. S.A. Vierteljahrsch. Astron. Ges., 48, p. 210, 1913.
- Rubens, H. Ann. d. Phys., 8, p. 2, 1902.
- Runge, C. Ber. Berlin Akad., III, p. 5, 1892.
- Rydberg, J. R. Kayser's Handbuch, II, 577.
- Saunders, F. Astrophysical Jour., 32, p. 165, 1910.
- Schumann, V. " " 3, pp. 220, 387, 1896.
" " 4, p. 144, 1896.
" " 11, p. 312, 1900.
Smithsonian Contributions, 1413, 24, 16, 29, 2.
Ann. d. Phys., 4, p. 642, 1901.
" " 5, p. 349, 1901.
Ber. Wien. Akad., 102, IIa, p. 415, 1893.
" " " " p. 625, "
" " " " p. 994, "
- Schuster, A. Theory of Optics, p. 325.
- Simon, H. Kayser's Handbuch, III, p. 45.
- Soret, J. L. Arch. d. Sc. Phy. et Nat. Période III, Vol. X, p. 453,
1883.
- Stark, J. Physik. Zeitsch., 6, p. 438, 1905.
- Steubing, W. Ann. d. Phys., 33, pp. 553, 572, 1910.
- Stokes, Sir G. G. Collected Works, IV, p. 221.
- Tian, A. Comptes Rendus, 155, p. 141, 1912; 152, p. 1483, 1911.
- Trowbridge, A. Zeitsch. f. Instru. Kunde., 30, p. 334, 1910.
- Voigt, W. Physik. Zeitsch., 2, p. 303, 1901.
- Wigand, A. " " 14, p. 1144, 1913.
- Wolff, K. Ann. d. Phys., 42, p. 825, 1913.
- Wood, R. W. Phil. Mag., 20, 707, 1910.
Astrophysical Jour., 26, p. 41, 1907.
- Wood & Hemsalech Phil. Mag., 27, p. 899, 1914.
- Wurmser, R. Journal d. Physique, 3, p. 305, 1913.
- Zschimmer, F. Zeitsch. f. Instru. Kunde., 23, p. 360.
" f. Elektrochem., 2, p. 629, 1905.
Physik. Zeitsch., 8, p. 611, 1907.

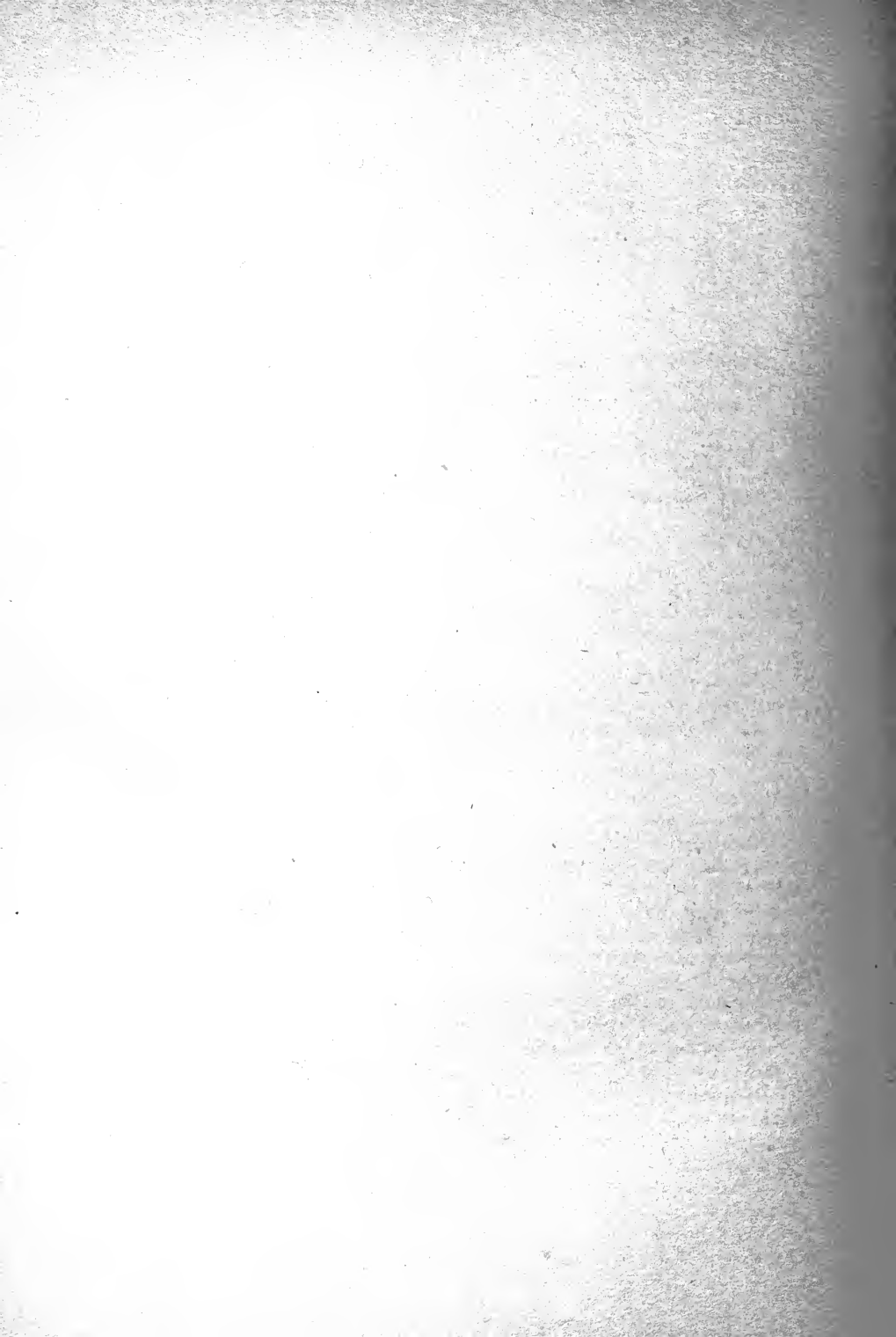

APPENDIX I.

LIST OF PAPERS OF V. SCHUMANN.

Sensitisation of photo-plates. Photo. Wochenblatt, p. 395, 1885; p. 49, 1886.
Das Zweite Spectrum des Wasserstoffs. Photo. Wochenblatt, p. 173, 1886.
Erythrosinsilber platten mit silberuberschuss. Photo. Correspondenz, p. 33, 1889.

Neue Versuche mit Cyanin. Photo. Rundschau, Heft 5, 6, pp. 143, 175, 1889.

Freies Silbernitrat in der Cyanin-gelatineplatte. Photo. Rundschau, Heft 6, p. 207.

Der Wert des Quarzes für die Spektralphotographie. Eders. Jahrbuch f. Photo., p. 225, 1889.

Einfluss der Temperatur auf das optische Vermögen eines Quarspectrographen. Eders. Jahrbuch f. Photo., p. 221, 1889.

Latest Researches on the Photography of Metallic Spectra. Chem. News, 62, p. 299, 1890.

Photographische Gesamtaufnahme des Spectrums zwischen den Wellenlängen 760 a 200 μ . Eders. Jahrbuch f. Photo., 4, p. 158, 1890.

Zur Photographie der brechbarsten Strahlen. Photo. Rundschau, 4, pp. 71-80, 1890.

On Determining the Sensitiveness of Photographic Plates by means of the Spectrograph. Chem. News, 63, p. 33, 1891.

Photo-chemical Researches. Chem. News, 63, p. 97, 1891.

Vacuum spectro photography. Chem. News, 64, p. 275, 1891.

Von der brechbarsten Strahlen und ihrer Photo. Aufnahme. Eders. Jahrbuch f. Photo., p. 217, 1891.

Ueber ein bisher unbekanntes Lichtgebiet von grosser photographieren Energie. Photo. Rundschau, pp. 185, 221, 259, 295, 1892.

Photographie der Lichtstrahlen kleinster Wellenlänge. Ber. Wien. Akad., 93, II, p. 415, 1892.

Ueber die Photographie des Gitterspectrums bis zur Wellenlänge 1000 AE in luftleeren Raum. Photo. Rundschau, p. 367, 1892.

Von der brechbarsten Strahlen und ihrer Photo. Aufnahme. Eders. Jahrbuch f. Photo., p. 234, 1892.

Ueber eine neue Ultra-violette empfindliche Platte. Wien. Akad. Anzeiger, 23, p. 230, 1892.

Das Absorptionsspectrum des Bronsilbers bei steigender Temperatur. Eders. Jahrbuch f. Photo., 7, p. 160-5, 1893.

Ueber die Photographie der Lichtstrahlen kleinster Wellenlänge. Ber. Wien. Akad., 102, IIa, pp. 415-75, 625-94, 1893.

Die Wasserstofflinie H β in Spectrum des neuen Sterns in Fuhrmann und in Spectrum von Vacuumröhren. Astrophysical Jour., 12, pp. 159-66, 1893.

Ueber ein neues Verfahren zur Herstellung ultra-violette empfindlicher Platten. Ber. Wien. Akad., 102, IIa, pp. 994-1024, 1893.

Von Wasserstoffspectrum. Eders. Jahrbuch f. Photo., 8, p. 59, 1894.

Zur Photographie d. Lichtstrahlen kleinster Wellenlängen. Wien. Akad. Anzeiger, Nr. 4-5, p. 24; Nr. 11-15, pp. 121-22, 1895.

Photography of the Light Rays of the Smallest Wave-lengths. Chem. News, 71, pp. 118, 248, 1895.

Von der brechbarsten Strahlen und ihrer Photographischen Aufnahme (4th part). Eders. Jahrbuch f. Photo., 9, pp. 198-201, 1895.

Ibid. (5th part), 10, pp. 42-5, 1896.

On a New Method of Preparing Plates Sensitive to the Ultra-violet Rays. Astrophysical Journal, 3, pp. 220, 387; 4, p. 144, 1896.

Von der brechbarsten Strahlen und ihrer Photo. Aufnahme. Eders. Jahrbuch f. Photo., 11, pp. 24-5, 1897; 12, pp. 20-2, 1898.

Ueber ein neues Spiegelmetall und dessen optische Untersuchung. Ber. Wien. Akad., 108, IIa, p. 136, 1899 (in collaboration with L. Mach).

A Second Spectrum of Hydrogen, etc. Astrophysical Jour., 11, pp. 312-13, 1900.

Zur Photographie der Lichtstrahlen kleinster Wellenlängen. Wien. Akad. Anzeiger, Nr. 10, pp. 71-2, 1900.

Zur Lichtdurchlässigkeit dünnen Glycerinschichten. Für Wiss. Photo., 2, pp. 113-14, 1900.

Ueber ein verbessertes Verfahren zur Herstellung ultra-violette empfindlicher Platten. Ann. d. Phys., 5, p. 349, 1901.

Zur Lichtdurchlässigkeit des Wasserstoffs. Ann. d. Phys. 4, pp. 642-45, 1901.

Smithsonian Contributions to Knowledge, 29, No. 1413, 1903.

APPENDIX II.

NO better method for making the dry plates which must be used in the extreme ultra-violet has been discovered than that minutely described by Schumann in the "Annalen der Physik," Vol. V, p. 349, 1901. There is really nothing of importance which can be added to this description. There are some points, however, which it may be well to emphasize.

The three essential properties of a good plate are freedom from fog and streaks, high sensitiveness, and fine grain. Purity of material and extreme cleanliness are necessary to secure the first condition. The emulsion should be flowed upon fresh glass plates; old photographic plates, from which the emulsion has been removed, should not be employed. The gelatine itself (Nelson No. 1) should be fresh and free from dust.

The sensitiveness of the plates depends primarily on the length of time during which the emulsion is heated and the temperature at which it is maintained during this heating; a half-hour at 60° C. is recommended by Schumann. The temperature at which the plates are maintained during the time the emulsion is settling upon them also influences the sensitiveness to some degree. 18° C. is the correct temperature for this process. If the operation is carried on at 25° or 30°, the sensitiveness is somewhat increased, but the fatal fault of halation is introduced.

The three desired properties of a good negative depend greatly on the constitution of the developer, upon its temperature, and upon the time of development. I have tried the Pyrogallol-soda formula recommended by Schumann, Metol, Rodinol, and several other developers, but I prefer an Ortol-

potash developer made according to the formula of J. Hauff & Co. on account of its flexibility.

Solution A	{	Water	1000 parts.
		Metabisulphite of potash	7½ parts.
		Ortol	15 parts.
Solution B	{	Water	1000 parts.
		Carbonate of potash	60 parts.
		Sulphate of soda (crystal)	180 parts.

I employ 15 parts A, 30 parts B, 20 parts water. The temperature is a most important factor. To secure uniform results the developer is cooled to 3° or 4° and is kept on ice during development. For plates two or three months old, the time of developing is usually two to three minutes.

Strong developer at room temperature results in rapid development, which, in turn, produces negatives with a coarse grain and, ultimately, complete fog.

SUBJECT INDEX.

- ABSORPTION spectroscopes, 51.
Air, absorption of, 24, 62, 71.
— spark lines, 91.
Alloys, reflecting power of, 26.
Alum, absorption of, 59.
Aluminum, spark spectrum of, 90.
Argon, absorption of, 70.
— spectrum of, 86.
Argon and hydrogen, spectrum of, 79.
Atmosphere, absorption of, 16.
- BACTERIACIDAL action of ultra-violet light, 103.
Barite, absorption of, 59.
Barium, spark spectrum of, 93.
Bismuth, reflecting power of, 27.
Boric anhydride, absorption of, 60.
- CADMIUM, arc spectrum of, 97.
Calcium, spark spectrum of, 93.
Carbon dioxide, absorption of, 68.
— spectrum of, 83.
Carbon monoxide, absorption of, 68.
— spectrum of, 83.
Cobalt, reflecting power of, 27.
Celestite, absorption of, 59.
Colemanite, absorption of, 59.
Copper, reflecting power of, 26.
— spark spectrum of, 89.
- FLUORITE, absorption of, 14, 57.
— dispersion of, 61.
- GELATINE, absorption of, 53.
Glass, absorption of, 11.
Glycerine, absorption of, 13.
Gold, reflecting power of, 26.
— spark spectrum of, 89.
Gypsum, absorption of, 59.
- HELIUM, absorption of, 69.
— spectrum of, 86.
Hydrogen, absorption of, 70.
— spectra of, 74.
- ICELAND spar, absorption of, 13.
Iodine, reflecting power of, 27.
Iron, reflecting power of, 26.
— spark spectrum of, 95.
- LIMIT of spectrum, 105.
- MAGNALIUM, reflecting power of, 26.
Magnesium, spark spectrum of, 94.
Mercury, arc spectrum, 97.
— reflecting power of, 27.
— spark spectrum of, 89, 94.
— lamps, use in biological experiments, 99.
— decay of efficiency, 13, 100.
Metals, reflecting power of, 25.
- NICKEL, reflecting power of, 26.
Nitric oxide, absorption of, 71.
Nitrogen, absorption of, 63.
— spectra of, 82.
- OXYGEN, absorption of, 18, 63, 99.
— spectrum of, 82.
Ozone, absorption of, 19-25, 68.
— production of, 66.
- PHOTO-ELECTRIC cell in photometry, 8.
Photo-electric effect, 103.
Photography, use of in photometry, 5.
Photographic plates, preparation of, 53.
Photometer, micro-, 5.
Photometer, spectro-, 4.
Platinum, reflecting power of, 26.
- QUARTZ, absorption of, 13, 56.
- ROCK SALT, absorption of, 13, 57.
- SCATTERING of sunlight, 22.
Selenium cell, 9.
— reflecting power of, 27.
Series spectra, alkali earths, 92.
— hydrogen, 77.
Silver, reflecting power of, 26.
— spark spectrum of, 89.
Solar spectrum, limit of, 15.
Spectroscopes, vacuum, 31, 33-43.
Strontium, spark spectrum of, 93.
Sugar, absorption of, 59.
- THERMOPILE, use in photometry, 10.
Tin, spark spectrum of, 89.
Topaz, absorption of, 59.
- UVIOL glass, 11.
- WATER, absorption of, 60.
Water vapour, absorption of, 71.
Wood's fusible alloy, reflecting power of, 27.
- ZINC, arc spectrum, 97.
— reflecting power of, 27.
— spark spectrum of, 89.

INDEX OF AUTHORS

- ABBOT, C. G., 22.
 Angström, K., 2.
- BECQUEREL, E., 1.
 Bloch, L. & E., 64.
 Bragg, W. H., 107.
 Buisson, H., 5, 19.
- CORNU, A., 3, 14.
 Crookes, Sir W., 3.
 Coblentz, W. W., 9.
 Cuthbertson, C., 73.
- DEMBER, H., 18, 108.
 Deslandres, H., 84.
 Dewar, Sir J., 18.
 Defregger, F. P., 6.
 Draper, J. W., 1.
 Dufour, A., 81.
- EINSTEIN, A., 104.
 Elster, J., 8.
 Esselbach, E., 2.
- FABRY, CH., 5, 19.
 Fowle, F. E., 23.
 Fowler, A., 77.
 Fritsch, C., 12, 60.
 Fulcher, G. S., 81.
- GEIGER, L., 4.
 Geitel, H., 8.
- HAGEN, E., 10, 25.
 Hallwachs, W., 7.
 Handke, F., 33, 56, 61, 89.
 Hartley, W. N., 19.
 Helmholtz, H., 1.
 Henri, V., 6.
 Herchefinkel, H., 85.
 Hertz, H., 7.
 Hughes, A. L., 9, 98.
- IVES, H. E., 8.
- KAYSER, H., 33, etc.
 King, L. V., 23.
 Königsberger, J., 7.
 Kreuzler, H., 8, 60, 62, 63, 68, 71.
 Krüger, F., 9, 19.
 Krüss, H., 7, 11.
- LADD, Miss, 65.
 Ladenburg, E., 19.
 Laue, M., 107.
 Larmor, Sir J., 65.
 Lehmann, E., 17.
 Lenard, P., 65, 91, 107.
 Liveing, C. D., 18.
- MARTENS, F. F., 61.
 Mascart, E., 2.
 Meier, W., 27.
 Meyer, E., 9, 19.
 Miethe, A., 17.
 Miller, W. A., 2.
 Minor, R. S., 27.
 Moeller, M., 9, 19.
 Morris-Airey, H., 33, 90.
- NICHOLSON, M. A., 81.
 Nutting, P. G., 7.
- PALMER, F., Jr., 65, 103.
 Paschen, F., 95.
 Pfüger, A., 9, 10, 11.
 Pohl, R., 105.
 Pring, J. N., 21.
 Pringsheim, P., 105.
- RAMSAUER, C., 91, 107.
 Richardson, O. W., 10.
 Ritter, J. W., 1.
 Ritz, W., 77, 92.
 Rosenberg, H., 9.
 Rowland, H., 2.
 Rubens, H., 9, 10, 25.
 Runge, C., 33.
 Rydberg, J. R., 80.
- SAUNDERS, F., 92.
 Schott & Co., 11.
 Schumann, V., 3, 13, 24, 29, 53, 56, 62,
 63, 68, 70, 76, 82, 84, 88.
 Schuster, A., 22.
 Simon, H., 6.
 Smyth, C. Piazzi, 3.
 Soret, J. L., 53.
 Stark, J., 4, 96.
 Steubing, W., 64, 82, 99.
 Stokes, Sir G. G., 1, 57.

TIAN, A., 98.
Trowbridge, A., 33.

VOIGT, W., 27.

WIGAND, A., 17.
Wolf, K., 33, 83, 86, 96.

Wood, R. W., 65, 107.
Wurmser, R., 6.

YOUNG, T., I, 2.

ZSCHIMMER, F., II, 60.

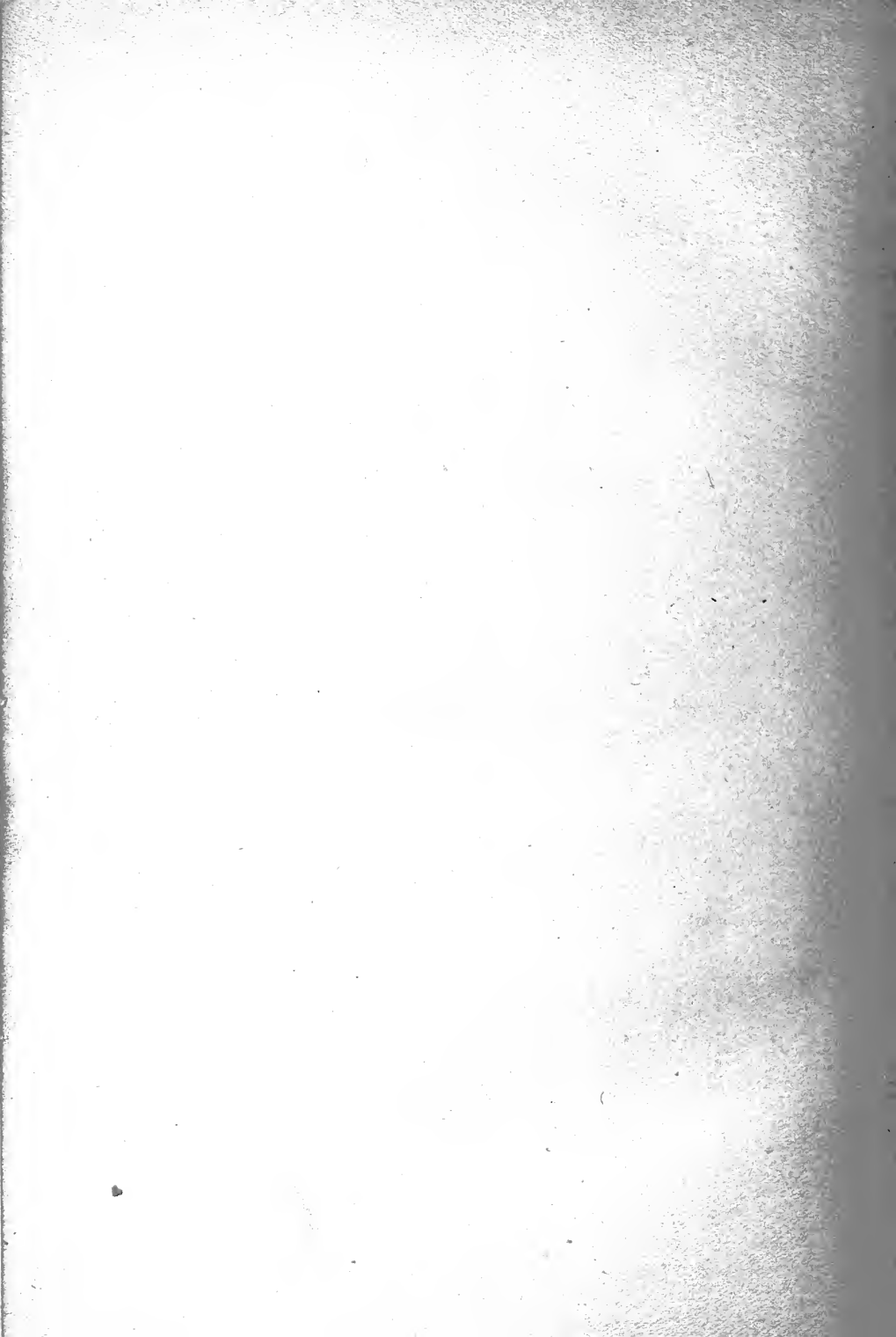

**THIS BOOK IS DUE ON THE LAST DATE
STAMPED BELOW**

**AN INITIAL FINE OF 25 CENTS
WILL BE ASSESSED FOR FAILURE TO RETURN
THIS BOOK ON THE DATE DUE. THE PENALTY
WILL INCREASE TO 50 CENTS ON THE FOURTH
DAY AND TO \$1.00 ON THE SEVENTH DAY
OVERDUE.**

FEB 7 1939

NOV 4 1946

MAY 5 1950

REC'D LD

JUN 27 1957

FEB 1 1958

REC'D LD FEB 26 '73 - 12AM 9 1

LD 21-95m-7,'37

308201

his
all
L9

UNIVERSITY OF CALIFORNIA LIBRARY

