

REPAIR, EVALUATION, MAINTENANCE, AND
REHABILITATION RESEARCH PROGRAM



US Army Corps
of Engineers

TECHNICAL REPORT REMR-CO-1

STABILITY OF RUBBLE-MOUND
BREAKWATER AND JETTY TOES;
SURVEY OF FIELD EXPERIENCE

by

Dennis G. Markle

Coastal Engineering Research Center

DEPARTMENT OF THE ARMY
Waterways Experiment Station, Corps of Engineers
PO Box 631, Vicksburg, Mississippi 39180-0631

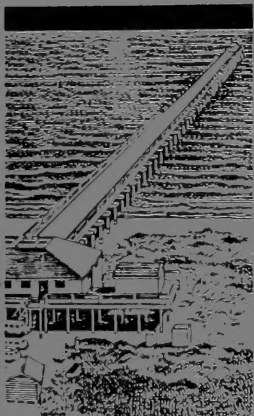

December 1986

Final Report

Approved For Public Release Distribution Unlimited

Prepared for DEPARTMENT OF THE ARMY
US Army Corps of Engineers
Washington, DC 20314-1000

Under Civil Works Research Work Unit 32278

TC
203
.6.55
no. REMR-
CO-1

The following two letters used as part of the number designating technical reports of research published under the Repair, Evaluation, Maintenance, and Rehabilitation (REMR) Research Program identify the problem area under which the report was prepared.

<u>Problem Area</u>		<u>Problem Area</u>	
CS	Concrete and Steel Structures	EM	Electrical and Mechanical
GT	Geotechnical	EI	Environmental Impacts
HY	Hydraulics	OM	Operations Management
CO	Coastal		

For example, Technical Report REMR-CS-1 is the first report published under the Concrete and Steel Structures problem area.

Destroy this report when no longer needed. Do not return
it to the originator.

The findings in this report are not to be construed as an official
Department of the Army position unless so designated
by other authorized documents.

The contents of this report are not to be used for
advertising, publication, or promotional purposes.
Citation of trade names does not constitute an
official endorsement or approval of the use of
such commercial products.

COVER PHOTOS

TOP—Field Research Facility, Duck, North Carolina.

BOTTOM—One layer of 7.5-ton tritars used on 8- to 12-ton toe
buttressing stone. Tritar and concrete ribcap
rehabilitation of a portion of the Hilo Breakwater, Hilo
Harbor, Hawaii.



REPORT DOCUMENTATION PAGE

1a. REPORT SECURITY CLASSIFICATION Unclassified			1b. RESTRICTIVE MARKINGS	
2a. SECURITY CLASSIFICATION AUTHORITY			3. DISTRIBUTION / AVAILABILITY OF REPORT Approved for public release; distribution unlimited	
2b. DECLASSIFICATION / DOWNGRADING SCHEDULE				
4. PERFORMING ORGANIZATION REPORT NUMBER(S) Technical Report REMR-CO-1			5. MONITORING ORGANIZATION REPORT NUMBER(S)	
6a. NAME OF PERFORMING ORGANIZATION USAEWES, Coastal Engineering Research Center		6b. OFFICE SYMBOL (if applicable) WESCV	7a. NAME OF MONITORING ORGANIZATION	
6c. ADDRESS (City, State, and ZIP Code) PO Box 631 Vicksburg, MS 39180-0631			7b. ADDRESS (City, State, and ZIP Code)	
8a. NAME OF FUNDING / SPONSORING ORGANIZATION US Army Corps of Engineers		8b. OFFICE SYMBOL (if applicable)	9. PROCUREMENT INSTRUMENT IDENTIFICATION NUMBER	
8c. ADDRESS (City, State, and ZIP Code) Washington, DC 20314-1000			10. SOURCE OF FUNDING NUMBERS	
			PROGRAM ELEMENT NO.	PROJECT NO.
			TASK NO.	WORK UNIT ACCESSION NO. 32278
11. TITLE (Include Security Classification) Stability of Rubble-Mound Breakwater and Jetty Toes; Survey of Field Experience				
12. PERSONAL AUTHOR(S) Markle, Dennis G.				
13a. TYPE OF REPORT Final report		13b. TIME COVERED FROM Feb 84 TO Oct 85	14. DATE OF REPORT (Year, Month, Day) December 1986	15. PAGE COUNT 82
16. SUPPLEMENTARY NOTATION Available from National Technical Information Service, 5285 Port Royal Road, Springfield, VA 22161.				
17. COSATI CODES			18. SUBJECT TERMS (Continue on reverse if necessary and identify by block number)	
FIELD	GROUP	SUB-GROUP	Armor units Rubble mound Wave stability	
			Breakwaters Toe scour	
			Jetties Water waves	
19. ABSTRACT (Continue on reverse if necessary and identify by block number) The purpose of this survey of field experience is to present an overview of the coastal rubble-mound breakwaters and jetties built and/or maintained by the US Army Corps of Engineers that have or have had stability problems related to structure toes. Extensive discussions with US Army Corps of Engineers division and district personnel, along with review of district office files, revealed that rubble-mound toe stability is a major repair and rehabilitation problem that can be divided into two major design categories: (a) design of buttressing stone placed at the toe of an armor slope to prevent downslope slippage of primary armor, and (b) design of toe berm armor size and geometry that will be stable for incident wave and flow conditions and will prevent, or at least slow down, scour and undermining of a structure's toe. No firm guidance presently exists to aid Corps personnel with these two design problems, and most design work is carried out using				
(Continued)				
20. DISTRIBUTION / AVAILABILITY OF ABSTRACT <input checked="" type="checkbox"/> UNCLASSIFIED/UNLIMITED <input type="checkbox"/> SAME AS RPT. <input type="checkbox"/> DTIC USERS			21. ABSTRACT SECURITY CLASSIFICATION Unclassified	
22a. NAME OF RESPONSIBLE INDIVIDUAL			22b. TELEPHONE (Include Area Code)	22c. OFFICE SYMBOL

Unclassified

SECURITY CLASSIFICATION OF THIS PAGE

19. ABSTRACT (Continued).

limited local field experience on past successes and failures. Design guidance in this area is urgently needed and will be addressed through the use of coastal hydraulic model tests authorized and funded under the Repair, Evaluation, Maintenance, and Rehabilitation Research Program Work Unit titled "Rehabilitation of Rubble-Mound Structure Toes." This field survey was conducted under authority of this same work unit.

Unclassified

SECURITY CLASSIFICATION OF THIS PAGE

PREFACE

Authority to carry out this survey was granted the US Army Engineer Waterways Experiment Station (WES) Coastal Engineering Research Center (CERC) by the Office, Chief of Engineers (OCE), US Army Corps of Engineers, under the Repair, Evaluation, Maintenance, and Rehabilitation (REMR) Research Program Civil Works Research Work Unit 32278, "Rehabilitation of Rubble-Mound Structure Toes."

The survey of field experience, which fulfills one milestone of this work unit, was conducted under the general direction of Messrs. John R. Mikel and Bruce L. McCartney and Dr. Tony C. Liu, REMR Overview Committee, OCE; Mr. Jesse A. Pfeiffer, Jr., Directorate of Research and Development, OCE; members of the REMR Field Review Group; Mr. John H. Lockhart, REMR Problem Area Monitor, OCE; and Mr. William F. McCleese, REMR Program Manager, WES. The survey was carried out by personnel of CERC, WES, under general supervision of Dr. James R. Houston, Chief, CERC, and Mr. Charles C. Calhoun, Jr., Assistant Chief, CERC; and under direct supervision of Messrs. C. E. Chatham, Chief, Wave Dynamics Division, and D. D. Davidson, Chief, Wave Research Branch and REMR Coastal Problem Area Leader. Visitations to the US Army Corps of Engineers division and district offices to acquire survey data were made by Messrs. Dennis G. Markle and Robert D. Carver, Research Hydraulic Engineers; Mr. John P. Ahrens, Research Oceanographer; Messrs. Peter J. Grace, R. Clay Baumgartner, and Frank E. Sargent, Hydraulic Engineers; Messrs. Willie G. Dubose and Maury S. Taylor, Engineering Technicians; Mr. John M. Heggins, Computer Assistant; and Mrs. Lynette W. O'Neal, Engineering Aide, during the period February 1984 through October 1985. Review of the field experience data and preparation of this report were carried out by Mr. Markle. This report was edited by Ms. Shirley A. J. Hanshaw, Information Products Division, Information Technology Laboratory.

CERC would like to thank the personnel of the US Army Corps of Engineers division and district offices contacted and visited during this survey. The timely and thorough completion of this study would not have been possible without the outstanding assistance and information provided by these individuals.

Commander and Director of WES during publication of this report was COL Dwayne G. Lee, CE. Technical Director was Dr. Robert W. Whalin.

CONTENTS

	<u>Page</u>
PREFACE.....	1
CONVERSION FACTORS, NON-SI TO SI (METRIC) UNITS OF MEASUREMENT.....	3
PART I: INTRODUCTION.....	4
Background.....	4
Authority, Purpose, and Approach.....	4
PART II: FIELD EXPERIENCE.....	6
Summary of Contacts and Visitations.....	6
Pacific Ocean Division.....	8
North Pacific Division.....	13
South Pacific Division.....	25
Southwestern Division.....	25
Lower Mississippi Valley Division.....	29
South Atlantic Division.....	29
North Atlantic Division.....	40
New England Division.....	42
North Central Division.....	46
PART III: DISCUSSION.....	76
PART IV: CONCLUSION.....	78

CONVERSION FACTORS, NON-SI TO SI (METRIC)
UNITS OF MEASUREMENT

Non-SI units of measurement used in this report can be converted to SI
(metric) units as follows:

<u>Multiply</u>	<u>By</u>	<u>To Obtain</u>
feet	0.3048	metres
miles (US statute)	1.609347	kilometres
pounds (force)	4.44822	newtons
tons (force)	8896.444	newtons

STABILITY OF RUBBLE-MOUND BREAKWATER AND JETTY TOES;
SURVEY OF FIELD EXPERIENCE

PART I: INTRODUCTION

Background

1. Failure of rubble-mound breakwater and jetty toes is a problem whose solution has plagued the majority of the US Army Corps of Engineers (Corps) divisions and districts responsible for designing, constructing, and maintaining these structures. Instability of a rubble-mound structure's toe directly impacts on the primary armor stability and overall performance of a structure. In most instances, instability (failure) of a structure's toe does not become evident until it has resulted in damage to the primary armor which has progressed up to or above the still-water level (swl). This observable damage can range from a minor slumping or reorientation of a few armor units around the swl to the total disappearance of large numbers of armor units. Left unattended, this type of damage could propagate upslope at a rate dependent upon incident wave conditions and severity of the toe and lower slope armor damage. In many cases, it will result in either localized or widespread failure of the structure.

2. No guidance presently exists for the preparation of adequate repair and/or rehabilitation designs for damaged or failed rubble-mound structure toes. A concentrated effort to better understand the various types of toe stability problems and to develop and document effective repair methods is urgently needed. Through the development of sound design guidance, the need for frequent repair work will be minimized which will result in substantial dollar savings.

Authority, Purpose, and Approach

3. Under the Repair, Evaluation, Maintenance, and Rehabilitation (REMR) Research Program, the US Army Engineer Waterways Experiment Station's (WES's) Coastal Engineering Research Center (CERC) has been authorized and funded to

carry out a work unit under the Construction, Operation, and Maintenance Research Area titled "Rehabilitation of Rubble-Mound Structure Toes." The prime objective of this work unit is to develop guidelines for repair and/or rehabilitation of rubble-mound structure toes. This will be accomplished through conduct of the following four work phases:

- a. Through telephone contacts with design, construction, and operations personnel in the Corps' division and district offices it will be determined where structures exist that have, are felt to have, or have had toe-related stability problems. Once this is accomplished, follow-up visits will be made to the division and district offices to gain a better understanding of the problems, and the steps that were taken (if any) to alleviate the problems, and the relative success or failure of the repair or rehabilitation work.
- b. Once an overall understanding is gained of the various toe stability problems confronting field designers, they will be categorized according to type. Subsequent to this, general experimental model testing programs will be developed to address the various problem types. The goal of these tests will be to experimentally determine and document improved methodologies through which successful toe repair and rehabilitation work can be designed and carried out.
- c. The experimental model tests (both two- and three-dimensional) will be carried out over a 2-year period. During this time, the scope of the tests will be subject to periodic changes based on continued information obtained and additional understanding gained on the problems confronting field personnel.
- d. A thorough analysis of the data compiled during the model tests will be carried out in an effort to produce general rubble-mound toe repair, and rehabilitation guidelines and a comprehensive report covering the model tests and presenting the experimentally developed guidance will be prepared and published.

Item a has been completed and is reported herein. Continued efforts will be made to maintain contact with and to obtain additional information from field personnel faced with rubble-mound toe stability problems. Item b has been completed for the presently available data, and two-dimensional experimental model tests (Item c) have been developed and initiated. A three-dimensional test series (Item c) is being developed based on findings of the two-dimensional tests. As previously stated, Item b and, in turn, Item c are subject to change as more field experience information becomes available.

PART II: FIELD EXPERIENCE

Summary of Contacts and Visitations

4. During the period February 1984 to October 1985, 9 division and 21 district offices (Table 1) of the Corps were contacted by telephone in order to determine whether any rubble-mound toe stability problems presently exist or have existed on the coastal structures under the jurisdiction of the various offices. The points of contact at each district office were those recommended by the REMR Field Review Group members from the district's division office. Of the 21 districts contacted, 12 responded positively regarding existing or past toe stability problems.

5. Prior to a district office visit, a copy of the district's project index maps was obtained in order to become familiar with the authorized coastal structures and their current status. During the planning stages for a district visit, it was requested through the district point of contact that upon arrival at the district office a meeting be held so that a detailed explanation of the purposes of the visit could be given and so that an overview of the district's coastal structures and the various problems and repair histories related to them could be obtained. Notably, the Wave Research Branch (WRB) of CERC is funded for three REMR work units other than the one being addressed herein, namely, (a) "Use of Dissimilar Armor for Repair and Rehabilitation of Rubble-Mound Structures," (b) "Repair of Localized Damage to Rubble-Mound Structures," and (c) "Techniques of Reducing Wave Runup and Overtopping on Coastal Structures." In addition to these, the WRB has been authorized under the Coastal Program's Research and Development Work Unit titled "Breakwater Stability" to write case histories on all breakwaters and jetties built and/or maintained by the Corps of Engineers. All of these work units require the gathering of field data; and for this reason when WRB personnel visited a district office, data were gathered, when available, for each of the work units. It was requested that, where possible, the meeting be attended by district representatives from planning, design, engineering, construction, and operations. In this way, it was assumed that the data obtained would reflect all areas of concern relative to a district's coastal structures.

Table 1
Divisions and Districts Contacted

<u>District/Division</u>	<u>Method of Contact</u>		<u>Problems</u>
	<u>Telephone</u>	<u>Visitation</u>	
Honolulu/POD*	Yes	Yes	Yes
Alaska/NPD	Yes	Yes	No
Seattle/NPD	Yes	Yes	Yes
Portland/NPD	Yes	Yes	Yes
San Francisco/SPD	Yes	Yes	Yes
Los Angeles/SPD	Yes	Yes	No
Galveston/SWD	Yes	Yes	Yes
New Orleans/LMVD	Yes	Yes	Yes
Mobile/SAD	Yes	Yes	Yes
Jacksonville/SAD	Yes	Yes	No
Savannah/SAD	Yes	Yes	No
Charleston/SAD	Yes	Yes	No
Wilmington/SAD	Yes	Yes	Yes
Norfolk/NAD	Yes	Yes	No
Baltimore/NAD	Yes	Yes	Yes
Philadelphia/NAD	Yes	Yes	Yes
New York/NAD	Yes	Yes	No
_____/NED	Yes	Yes	Yes
Buffalo/NCD	Yes	Yes	No
Detroit/NCD	Yes	Yes	Yes
Chicago/NCD	Yes	Yes	No

* POD - Pacific Ocean Division; NPD - North Pacific Division; SPD - South Pacific Division; SWD - Southwestern Division; LMVD - Lower Mississippi Valley Division; SAD - South Atlantic Division; NAD - North Atlantic Division; NED - New England Division; NCD - North Central Division.

6. Following the entrance meeting, all available information on the district's coastal structures (design memorandums, plans and specifications texts and drawings, reconnaissance reports, photographs, etc.) were retrieved from the district's files and duplicated. The data were then taken back to CERC for scrutiny by the principal investigators assigned to the various work units.

7. Where representative structures were near the district offices, site visits were made to gain a better understanding of the type of construction used on the district's structure. During these site visits, photographs were taken to document the above-water conditions of the structures. Because of time constraints and remoteness of the structures, site visits were not possible at some of the district offices.

8. Prior to departure from the district office, an exit meeting was held for WRB personnel to summarize their findings to ensure that no misconceptions were drawn from the data gathered. Where possible, the same personnel attended the exit meeting as had attended the entrance meeting.

9. In some instances, the quantity of data contained in the district's files was so massive that time was not sufficient for WRB personnel to duplicate the data during the time allotted for the visit. When this situation occurred, a request was made for the district to provide personnel, when and where available, to duplicate data and send it to CERC. In some instances, it was determined that an additional visit to a particular district by WRB personnel was needed to adequately review the available data.

Pacific Ocean Division

10. The Honolulu District of POD has three breakwaters which have problems and/or design questions that are related to toe stability. Two of the structures, Nawiliwili and Hilo, had a related problem. The head and adjacent 500 ft* of breakwater trunk at Nawiliwili Harbor, Kauai, Hawaii (Figure 1), were rehabilitated in 1959 using 17.8-ton tribars. Model

* A table of factors for converting non-SI units of measurement to SI (metric) units is presented on page 3.

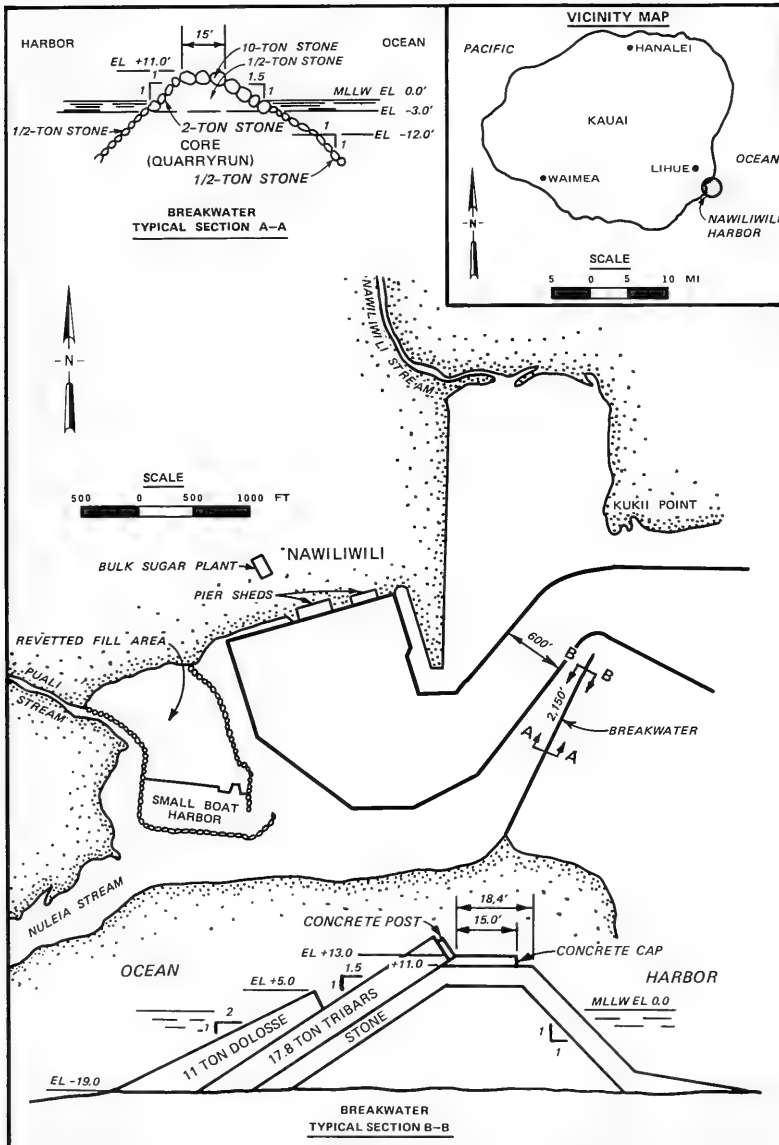

Figure 1. Nawiliwili Harbor Breakwater, Kauai, Hawaii

tests*, conducted at WES in 1958, revealed that two layers of randomly placed tribars on the head and one layer of uniformly placed tribars on the trunk were the best methods of rehabilitating the storm damaged structure. A survey in 1975 revealed extensive tribar breakage, and later it was found that the toe buttressing stone recommended for placement at the toe of the one layer of uniformly placed tribars had not been incorporated into the construction specifications. It was surmised that in the absence of these buttressing stones the tribar toe slid on the hard bottom which resulted in an en masse slippage and breakage of several tribars. This area was rehabilitated with two layers of randomly placed 11-ton dolosse on slope and through the use of special placement of the toe dolosse. This latter work was also model-tested at WES.**

11. A repair similar in design to that used on Nawiliwili in 1959 was completed on the Hilo Harbor Breakwater, Hawaii, Hawaii (Figure 2), in 1981. One layer of uniformly placed 7.5-ton tribars was placed on the sea-side slope of the breakwater between sta 11+00 and sta 20+00. Based on knowledge gained through the failure of the Nawiliwili tribar section, a row of 8- to 12-ton buttressing stone was incorporated into the toe repair. No design guidance is presently available to aid in sizing the buttressing stone for an incident wave environment, and no model tests were conducted. For this reason, close monitoring of the repair work should be carried out after storm events. Thus, POD and the Corps as a whole will gain from prototype experience which can be used to complement the data acquired during the experimental model tests on toe buttressing stone design proposed to be carried out under this work unit.

12. Haleiwa Harbor, located on the north side of the Island of Oahu, Hawaii (Figure 3), was modified in 1975 by the addition of a revetted mole and two stub breakwaters. Subsequent to this time, repairs were required on the 80-ft breakwater due to a slippage failure of the primary armor stone. Close inspection of the structure revealed that the bedding and berm had been

* R. A. Jackson, R. Y. Hudson, and J. G. Housley. 1960 (Feb). "Design for Rubble-Mound Breakwater Repairs, Nawiliwili Harbor, Nawiliwili, Hawaii," Miscellaneous Paper No. 2-377, US Army Engineer Waterways Experiment Station, Vicksburg, Miss.

** D. D. Davidson. 1978 (Jan). "Stability Tests of Nawiliwili Breakwater Repair," Miscellaneous Paper H-78-4, US Army Engineer Waterways Experiment Station, Vicksburg, Miss.

omitted from the construction. Localized scour had undermined the armor stone toe and resulted in the slippage failure. The structure was repaired by excavating around the perimeter of the structure down to firm bottom and overlaying the structure head with an additional layer of 1- to 2- ton armor stone which extended down to the toe. This repair was feasible due to the shallow depth of the sand in the area of the west breakwater. No stability problems have been observed since the repair was completed.

North Pacific Division

Seattle District

13. The south jetty at the entrance to Grays Harbor, Washington (Figure 4), has sustained severe scour on the channel side toe. The outer 5,600 ft of the jetty are presently below mean lower low water (mllw). It is not known if the toe scour is the cause, or a portion of the cause, of the present deteriorated condition of the jetty. Presently, no repair work is planned for the Grays Harbor Jetties.

14. As of August 1985 plans were being developed for the repair of the rubble-mound breakwaters at Edmonds Harbor, Washington (Figure 5). It is not definitely known that toe stability was a cause of some of the existing damage, but it is thought to be a probable cause. The bottom drops off on a 1V:2H slope to a deep depth just out from the toe of the breakwaters. There is some thought that this deep water adjacent to the structure, which allows large amounts of wave energy to reach the structure, could be initiating toe stability problems. No firm decisions had been made on the repair design when this report was being prepared.

Portland District

15. The north jetties at the mouth of the Columbia River, Tillamook Bay, Yaquina Bay, Siuslaw River, Coos Bay, and Rogue River, the south jetties at Nehalem Bay and Umpqua River, both jetties at the Chetco River, and Jetty "A" at the mouth of the Columbia River have all shown toe stability problems. The problems at these 11 sites (Figures 6-14) are the result of one or a combination of the following: (a) ebb and/or flood flows training on the channel side of the jetties which undermine the jetty toes, displace the toe berm stone or a combination of both, (b) wave- and flow-induced displacement of toe berm armor and foundation scouring and undermining at the jetty heads,

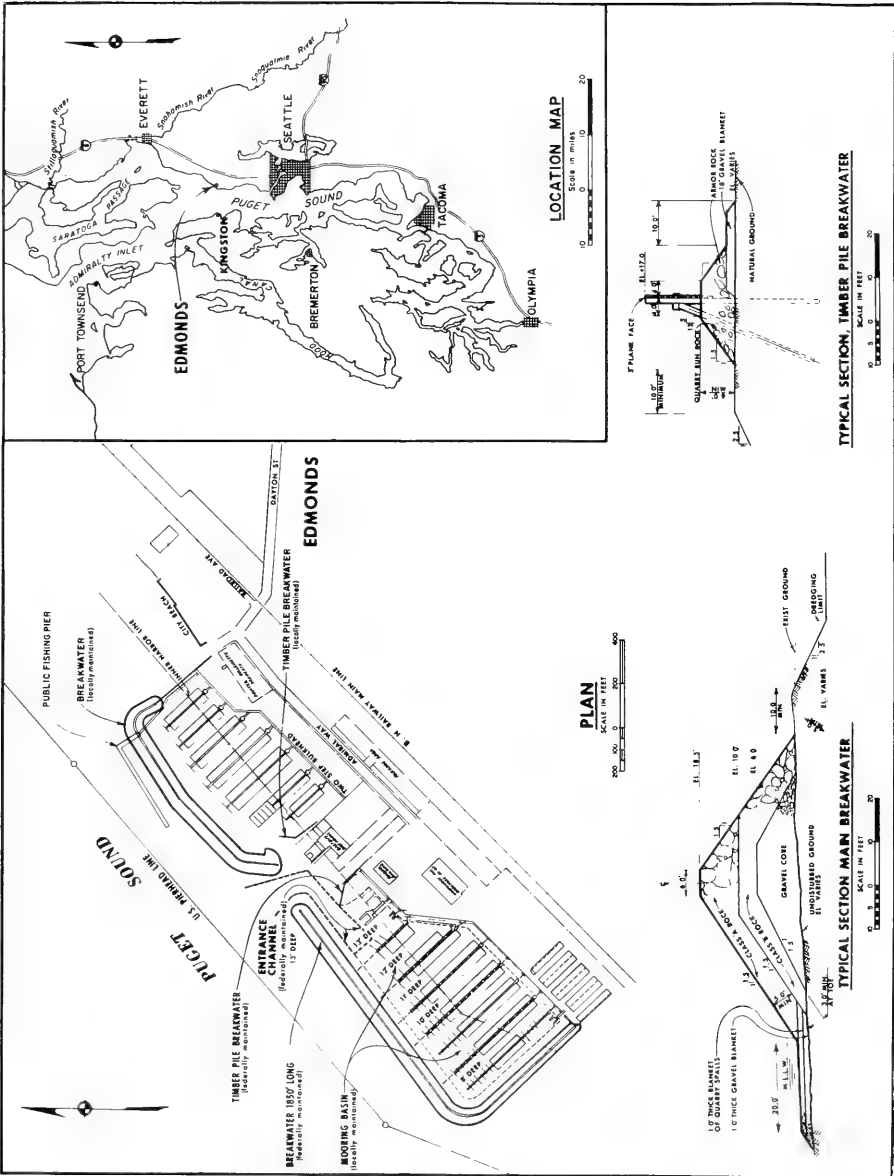

Figure 5. Edmonds Harbor Breakwaters, Washington

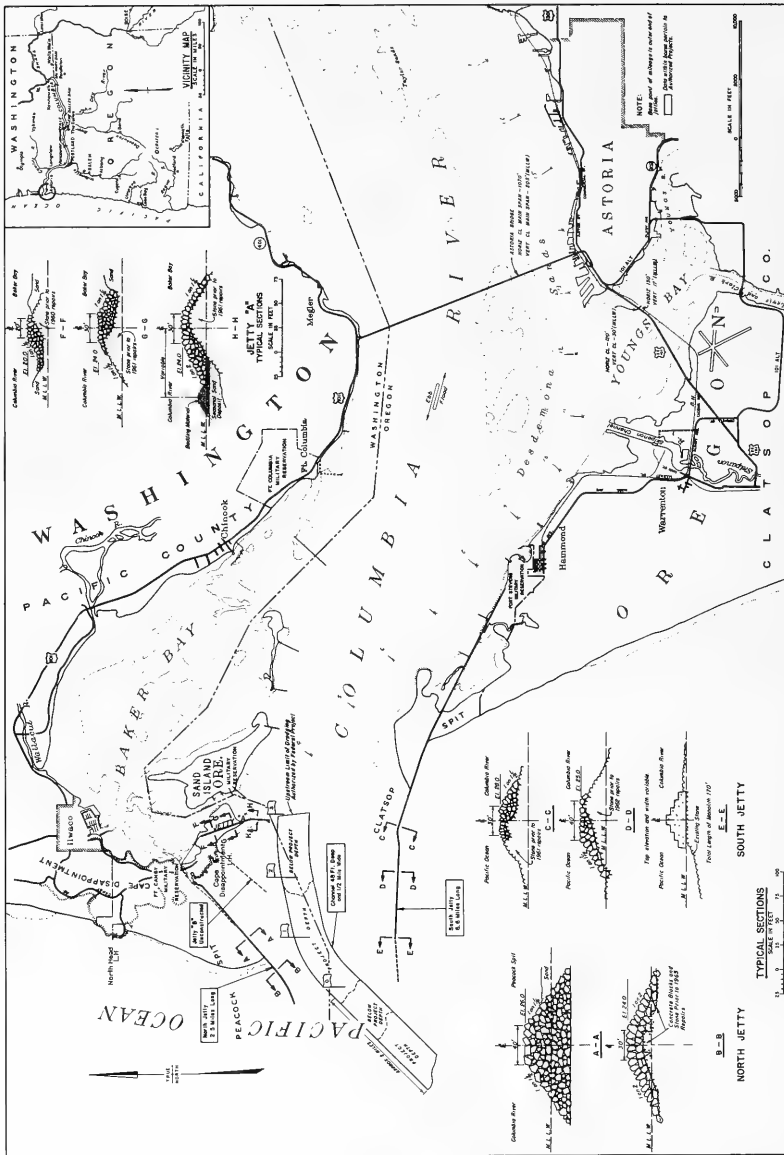

Figure 6. Mouth of Columbia River Jetties, Oregon

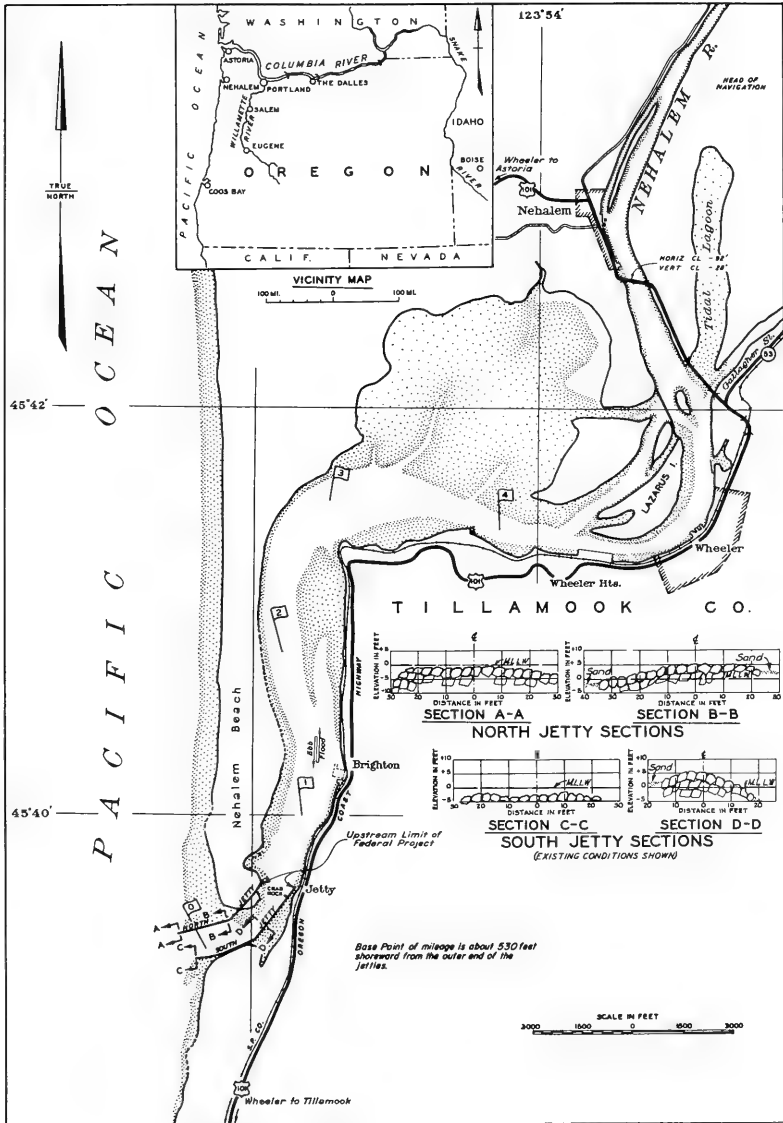

Figure 7. Nehalem Bay Jetties, Oregon

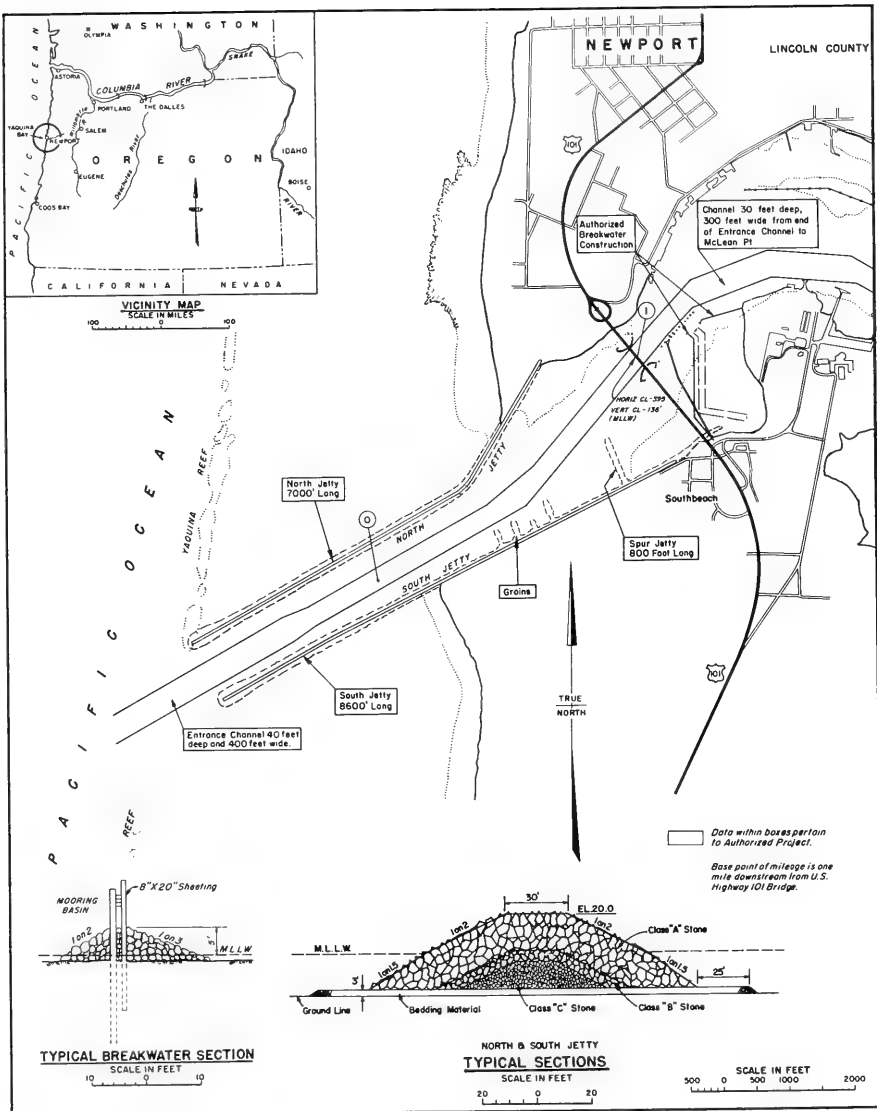

Figure 9. Yaquina Bay and Harbor Breakwater and Jetties, Oregon

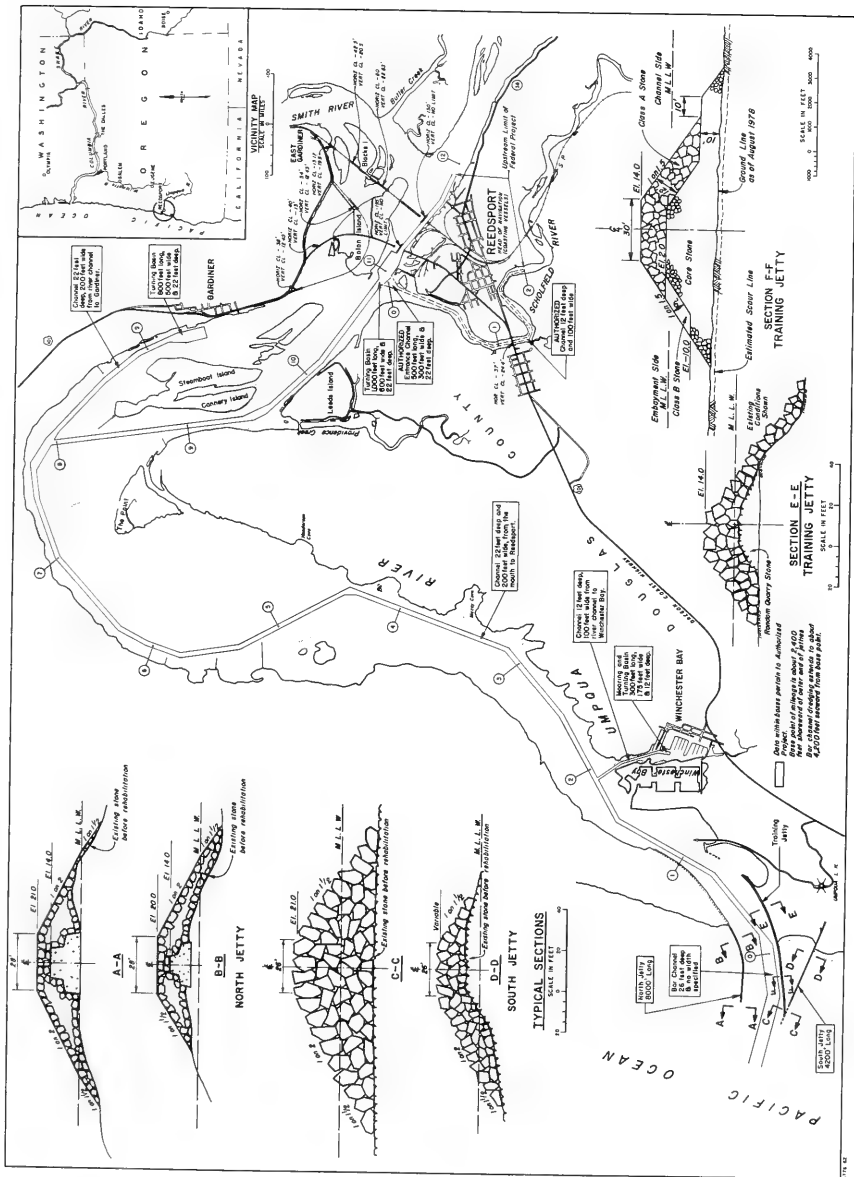

Figure 11. Umpqua River Jetties, Oregon

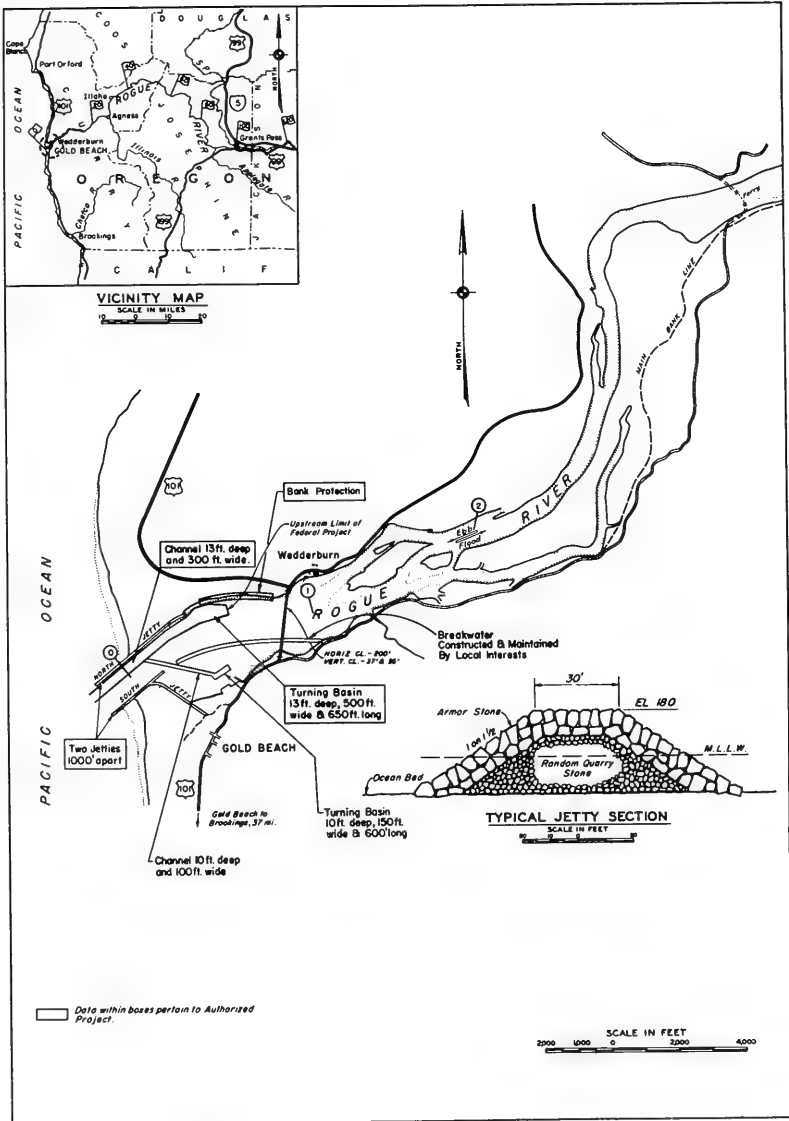

Figure 13. Rogue River Jetties, Oregon

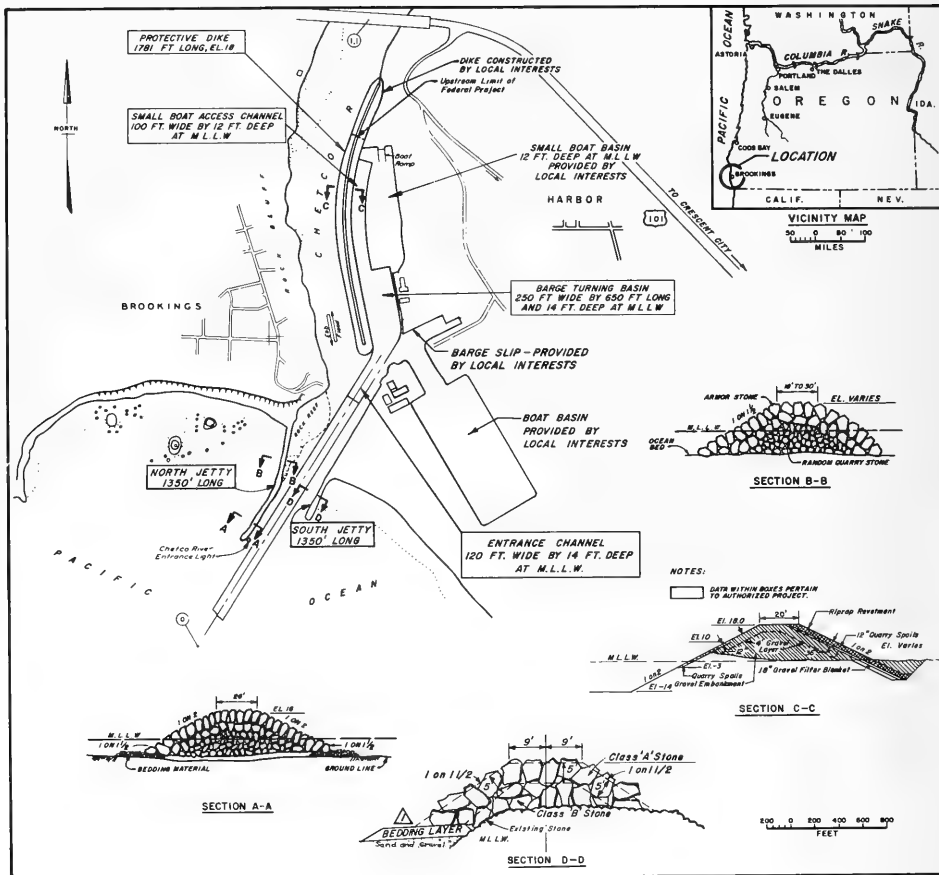

Figure 14. Chetco River Jetties, Oregon

and (c) wave-induced displacement of toe berm stone and/or scour of foundation material which results in undermining of the structure's toe. As a result of this displacement, scour, and/or undermining of the structure's toe, the primary armor stone layers become unstable and lead to structural failure. The Portland District carries out repair in these scour areas by filling the scour holes with small stone, core size or smaller, to form a foundation to rebuild the toe and upper portions of the structure. During the repairs and rehabilitations of the north jetty at Yaquina Bay and Jetty "A" at the mouth of the Columbia River, a sacrificial berm of core-sized material was placed at the structure's toe after the primary armor layers had been placed. It was thought that this material would help stabilize the jetty toes by slowing down the scour rate as well as providing some degree of armoring of the scour hole as the berm stone is displaced into the scour hole. In some instances, scour at the jetty heads has been so severe that it was not economically feasible to try to fill and stabilize the scour holes. The best approach in these cases was to abandon the outer 200 to 300 ft of the jetty heads and rehabilitate the remainder of the structure.

South Pacific Division

16. The San Francisco District sited the jetties at Humboldt Bay (Figure 15) as being the only area showing obvious toe stability problems. The channel side of the north jetty and exposed side of the south jetty have shown obvious signs of scour and undermining which resulted in instability and slippage of the dolos toe. Condition surveys of the area have revealed the depths of the scour holes appear to have a seasonal fluctuation. An armor stone berm, extending from 70 to 100 ft out from the existing dolos toes, was included in the jetty repair work conducted in 1985. The multilayered berm consists of a 3- to 6-ton primary armor stone overlying two graded filter layers (Figures 16 and 17).

Southwestern Division

17. Several rubble-mound structures in the Galveston District have experienced toe stability problems. Recent attempts to improve stability include the construction of toe berms of core sized material at the toe

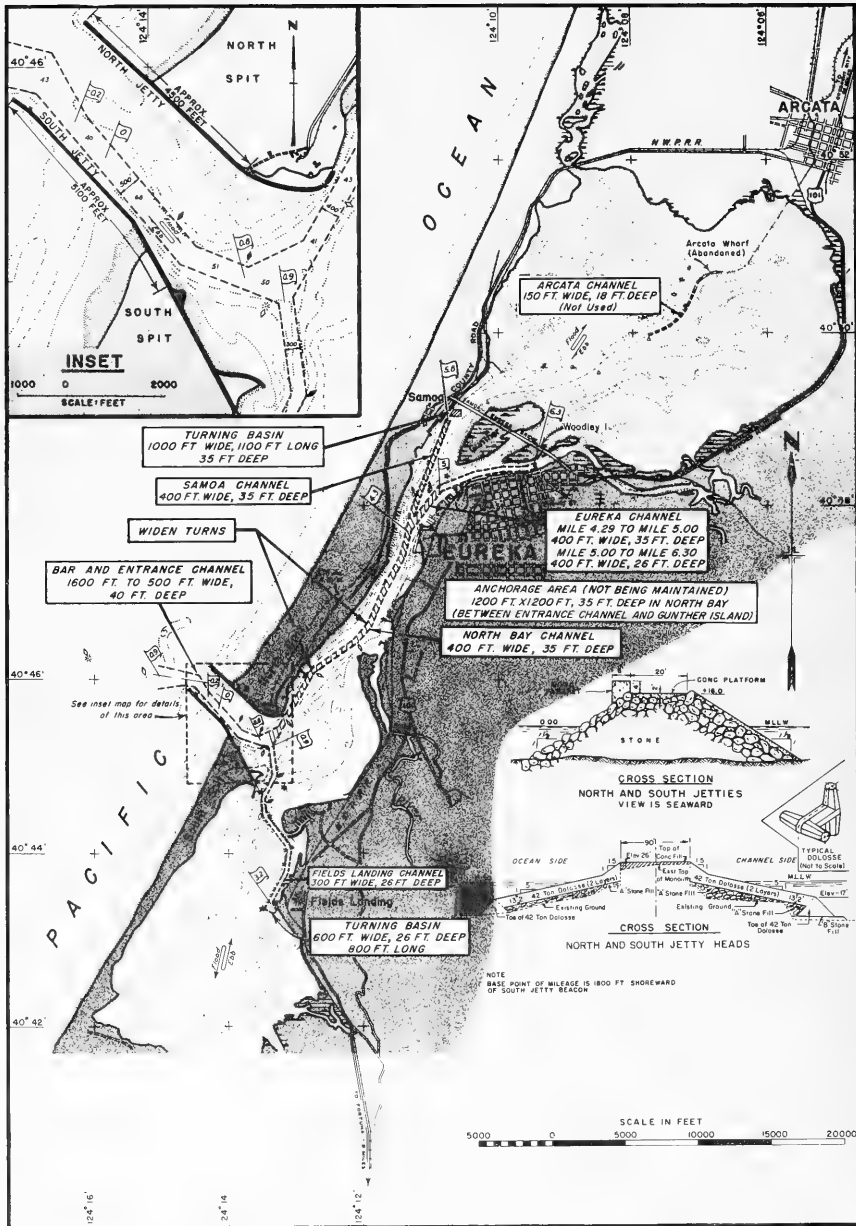

Figure 15. Humboldt Bay Jetties, California

of the structures. Insufficient data were available to make a judgment on the success of the berms.

Lower Mississippi Valley Division

18. The New Orleans District has a unique design problem in that the majority of their jetties are constructed on very soft foundations. It is thought that a majority of the repair and rehabilitation work required on the jetties results from the structures sinking into the foundation. The jetties at Southwest Pass and Mississippi River Gulf Outlet (Figures 18-20), have required considerable repair work due to this subsidence, but it is thought that some of the damage on small localized areas of these jetties is the result of toe slippage. Toe slippage in turn results in downslope slippage of the primary armor resulting in loss of jetty design elevations. Efforts have been made to use toe berms to reduce toe slippage and help prevent foundation slip failures caused by the loading of the jetty construction materials. The berms have provided some additional toe stability, but subsidence of the jetties and slippage of the jetty toes and foundations continue to plague the New Orleans District.

South Atlantic Division

Mobile District

19. The Mobile District has a problem with jetty subsidence but, unlike the New Orleans District's problem, theirs is not thought to be related to low-density foundations. It is generally thought that toe scour is the significant problem after major storms. Bedding layers slough off into the scour holes, and this damage migrates back to the toe of the primary armor. The resulting instability of the armor stone toe leads to downslope migration of the onslope armor and eventual deterioration of the structures.

20. During the period 1937 to 1938 attempts were made to alleviate toe scour problems on the Panama City Harbor Jetties (Figures 21 and 22) by encasing the jetties with asphaltic concrete. Asphaltic concrete mats (2 in. thick) were anchored on the channel side of the jetties and extended over the jetties to a point 24 ft seaward of the existing jetty toe. A hot asphaltic concrete was poured over the matting in an effort to bond the mats together

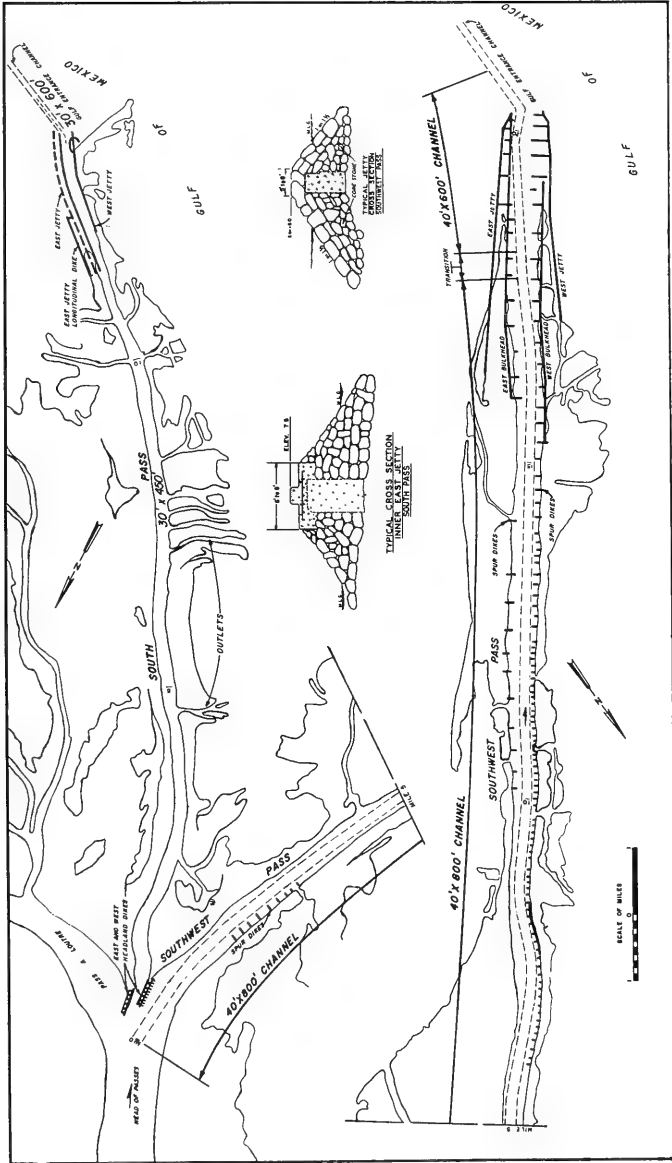

Figure 19. Details of South and Southwest Jetties, Louisiana

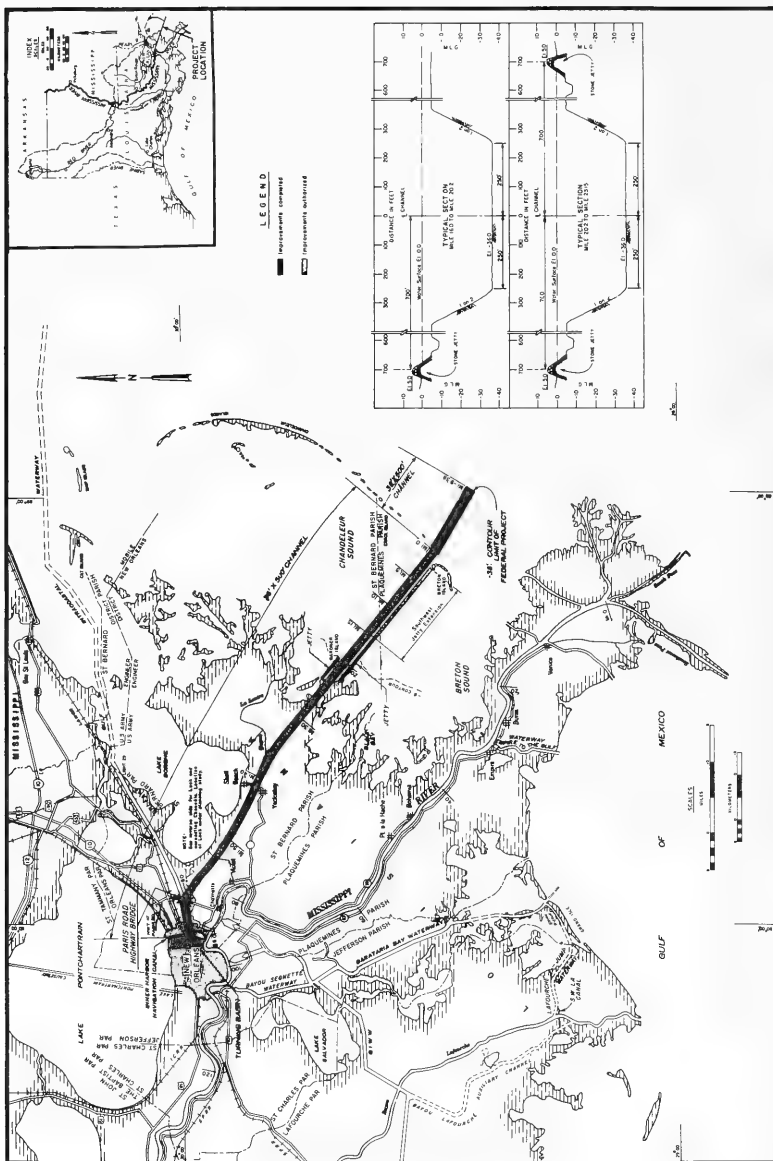
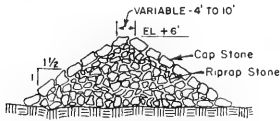
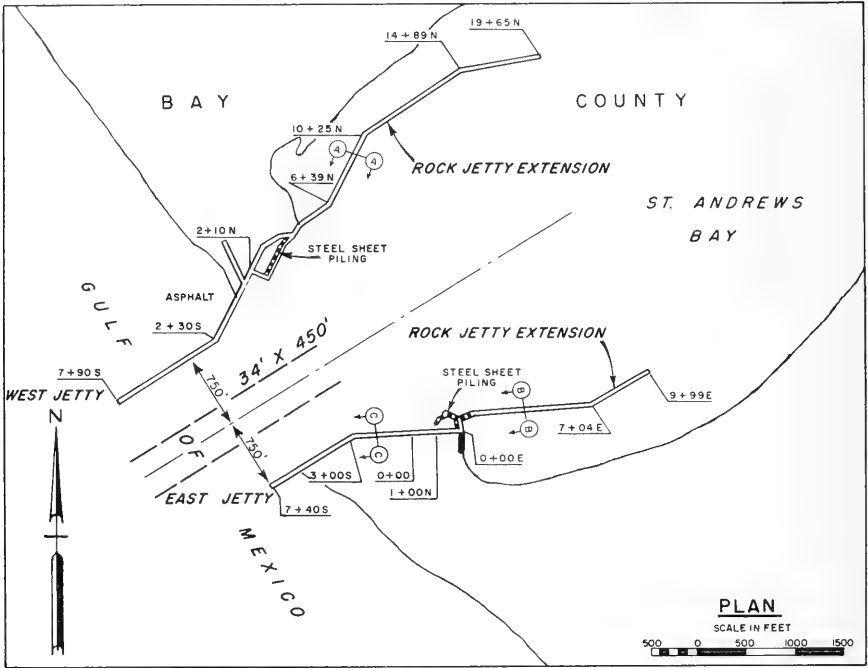
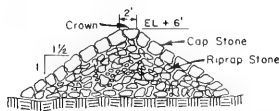

Figure 20. Mississippi River Gulf Outlet Jetties, Louisiana



SECTION A-A



SECTION B-B

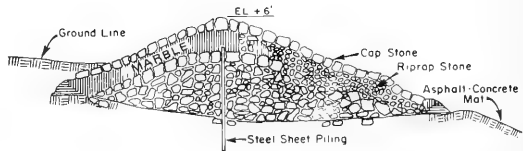

SECTION C-C

Figure 22. Details of Panama City Harbor Jetties, Florida

as well as stabilize them to the existing armor stone structure. This design proved to be unsuccessful. Scour initiated at the toes of the mats and, as the mats subsided into the scour holes, they pulled the mats and armor stone off the upper slope which resulted in general deterioration of the jetties. Subsequent repairs were carried out by placing a toe berm of 100- to 200-lb stone and, where needed, overlaying the old structure with additional armor stone.

21. Toe scour also has been noted as a problem with the jetties at East Pass Channel and St. George Island, Florida, and Perdido Pass Channel, Alabama (Figures 23-25, respectively). Scour on the channel side of the east jetty at East Pass is so severe that it is thought that portions of the jetty may slide into the channel at any time. In the past, this type of slippage failure has caused severe damage to the west jetty at Panama City.

22. Jetties at St. George Island have suffered cover stone loss resulting from the undermining action of toe scour. The west jetty at Perdido Pass presently has significant amounts of toe scour on the channel side, and Hurricane Frederick produced significant amounts of toe scour on the east jetty. The overall condition of the Perdido Pass jetties was said to be good; therefore, it is assumed that the toe scour has not caused any obvious damage above the waterline.

Wilmington District

23. The 3,650-ft-long rubble-mound north jetty located at Masonboro Inlet, North Carolina (Figure 26), was constructed between August 1965 and June 1966. The north jetty required extensive repair on the channel-side toe of the outer rubble-mound structure in 1969 and to the channel-side toe of the inner weir section in 1973. This was prior to construction of the south jetty (14- to 22-ton armor stone) in 1980. It was thought that ebb and flood flows had caused the channel to move adjacent to the north jetty, creating the scour problem. In both repairs, a 2- to 3-layer protection of bedding material and riprap (25 to 2,000 lb) was used. This toe protection butted against the existing armor stone toe or sheet-pile weir. The berm width varied from 30 to 50 ft. It is thought that this work had limited success because the jetty has not totally deteriorated, but it is presently in need of repair work in several areas. Presently it is unknown whether the deteriorated appearance of the north jetty results from a toe scour problem or from the possibility

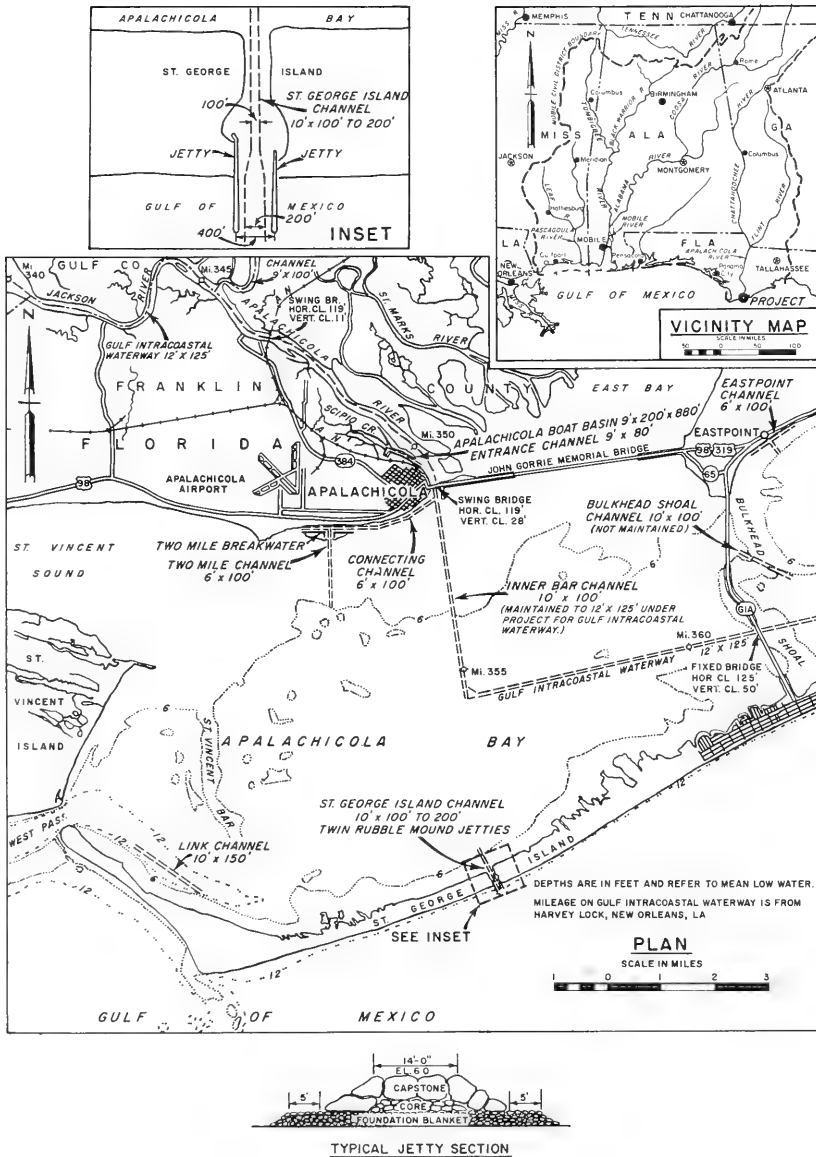

Figure 24. St. George Island Jetties, Florida

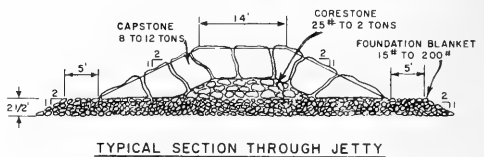
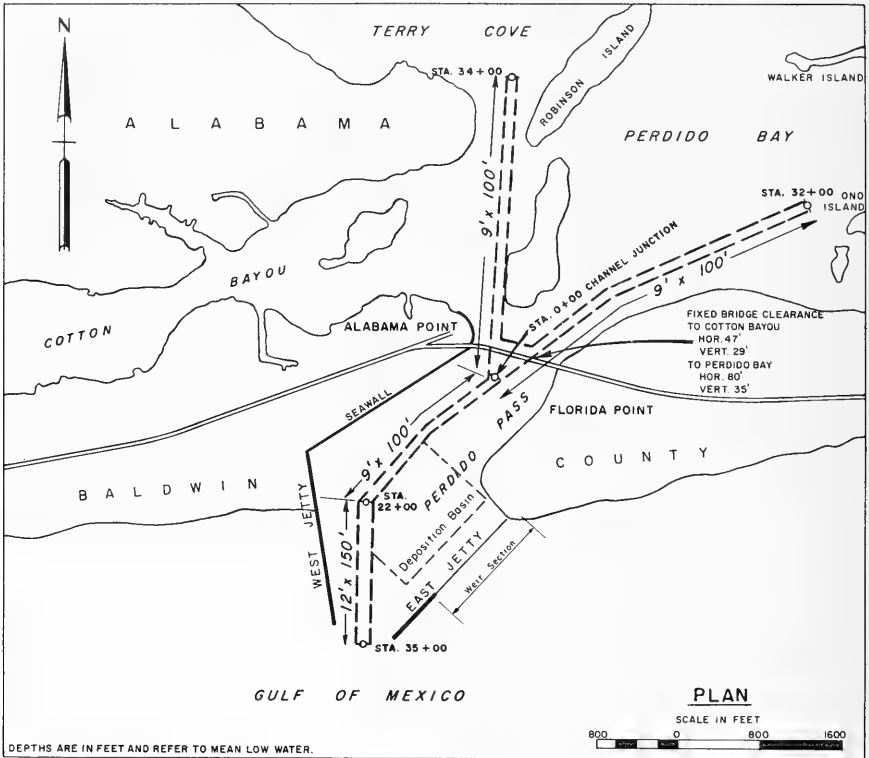

Figure 25. Perdido Pass Channel Jetties, Alabama

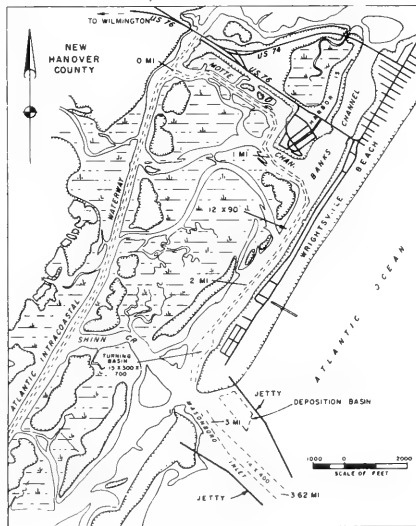
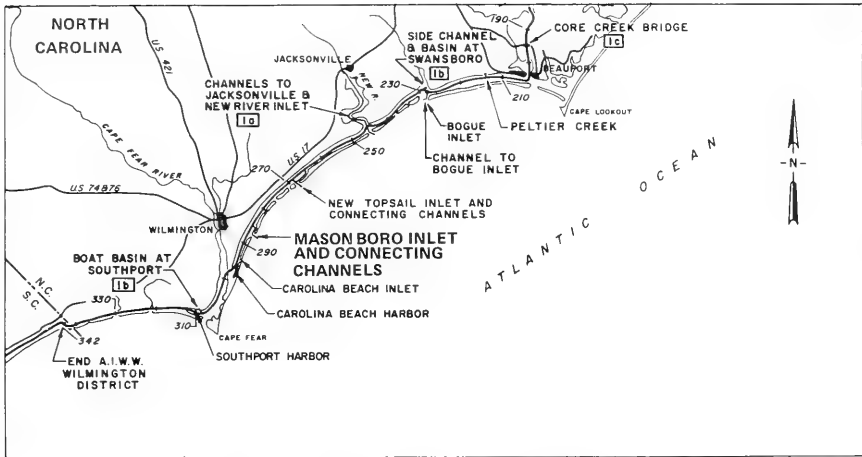

Figure 26. Masonboro Inlet Jetties, North Carolina

that the original 7- to 12-ton armor stone may have been an inadequate design for the incident wave environment.

North Atlantic Division

Baltimore District

24. The south jetty at Ocean City Inlet, Maryland (Figure 27), is the only structure within the Baltimore District that was reported as having significant toe stability problems. The original north and south jetties, both rubble mound, were constructed in 1934 and 1935, respectively. The crown elevation on the shoreward end of the north jetty had to be increased in 1937 to stop flow of sand into the inlet. The landward end of the south jetty required extensions in 1956 and 1963 to repair flanking caused by erosion. The south jetty has suffered major deterioration along its outer leg caused by ebb flow induced scour and undermining of the structure's inlet side toe. During major repair of the south jetty in 1963, the center line of the structure's repair section was offset outward from the inlet (Figure 27). This was done to alleviate the need to fill the massive scour hole that existed where the inlet side of the structure was originally constructed. The ocean side of the existing structure that remained was used as a base against which the inlet side toe of the jetty repair section was positioned. By 1982, the 1963 repair section of the south jetty was once again very deteriorated. Like the original, this damage was only on the converging portion of the jetty and was caused by ebb flow induced undermining of the structure's inlet side. In order to prevent failure of the outer end of the south jetty, which would lead to severe inlet shoaling, the scour hole adjacent to the structure was filled with dredge material and capped with stone. The lower portion of the inlet side of the jetty was overlaid with an intermediate stone size, and the remainder of the inlet side slope was covered with primary armor stone. This work was completed during 1983 to 1984, and a typical repair cross section is shown in Figure 27. The majority of the south jetty's original repair section still shows considerable deterioration and is highly overtopped. It is unknown how well the scour protection is performing. It appears that scour on the north side of the inlet has slowed down, and the north jetty is in good condition; however, the overall scour in the throat of the inlet shows no signs of stabilizing.

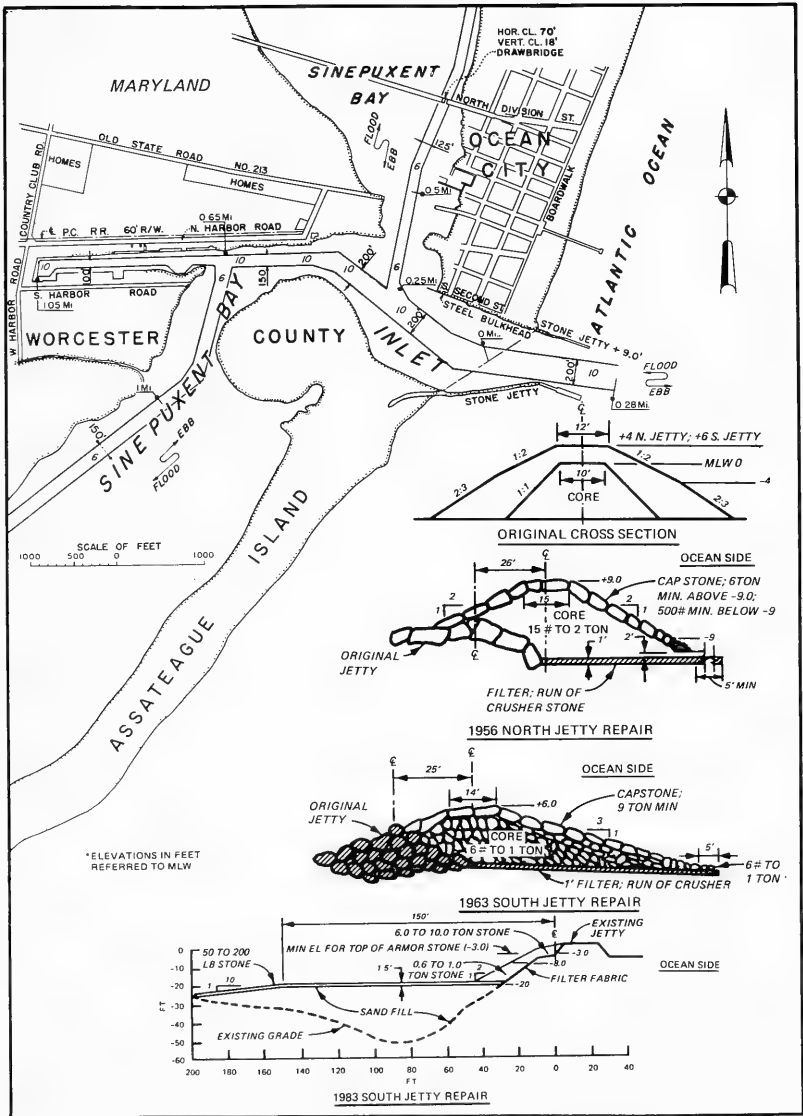

Figure 27. Ocean City Inlet Jetties, Maryland

Philadelphia District

25. The most common problem occurring on the Philadelphia District's coastal structures is subsidence of structures below design elevation. It is thought that toe scour contributes to this, but the primary cause is poor foundation conditions in the areas where most of the structures have been built. This is especially true for those structures located in the Delaware Bay area.

26. The jetties located at Reedy Point, where the Chesapeake and Delaware Bay Canal intersects the Delaware River, were originally constructed prior to 1938 (Figure 28). Both structures were of rubble-mound construction. In the 1960's the existing south jetty was removed, and a new south jetty was constructed farther south. This was done to increase the entrance size to accommodate larger vessels and improve navigation safety. The present jetties are both 2,095 ft long, and it was reported that the north jetty has problems with toe scour, loss of armor stone, and overall subsidence.

27. The rubble-mound and sheet-pile composite jetties at Indian River Inlet, Delaware, were completed in 1939 (Figure 29). The jetties required storm damage repairs in 1956 and 1957. At that time, the north jetty was extended inshore a distance of 320 ft. At present both jetties are 1,566 ft long. Both jetty heads have deteriorated significantly from a combination of toe scour, armor stone slippage and displacement, and overall subsidence. Because of the success of the Manasquan River Jetty repairs, dolosse are being considered for inclusion in the repair and rehabilitation designs for the structure slopes. No details on the proposed toe repair design are available.

New England Division

28. Based on review of historical repair data, it appears that three project sites within the New England Division that contain rubble-mound jetty structures have exhibited stability problems which could be related to instability of the structure toes. Both jetties at the mouth of the Kennebec River, Maine (Figure 30), have a history of extension and repair. The latest jetty rehabilitation work was completed in 1982. Recent inspections show that both jetty heads are damaged and that 250 ft of the channel side of the east jetty have been undermined. The most recent inspection reports (1973-74), indicate that the north and south jetties at Newburyport Harbor, Massachusetts

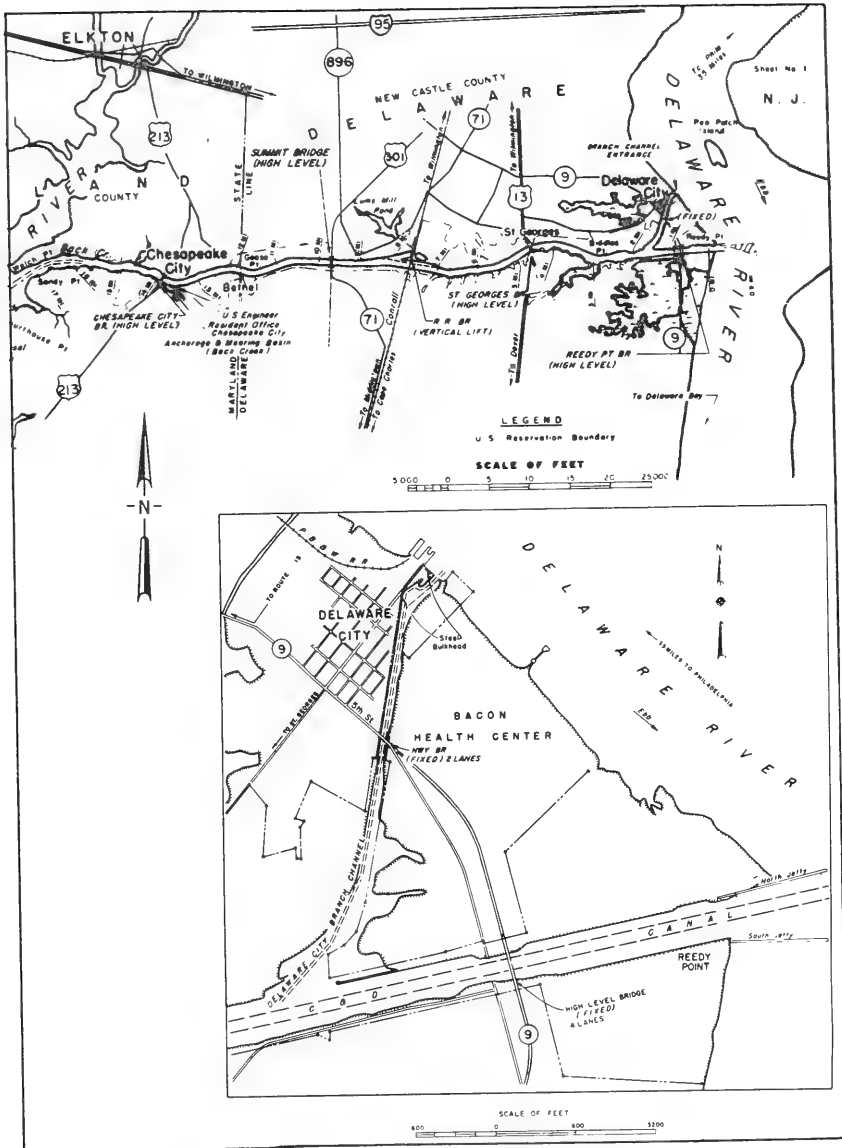

Figure 28. Reedy Point Jetties, Delaware

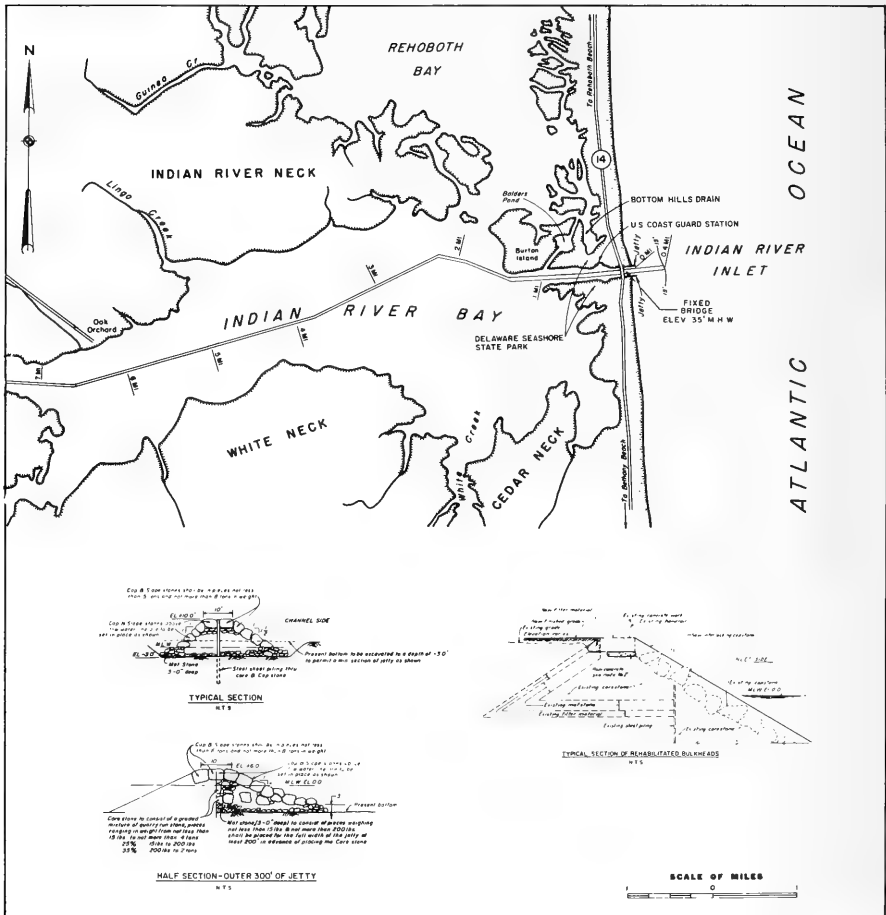

Figure 29. Indian River Inlet Jetties, Delaware

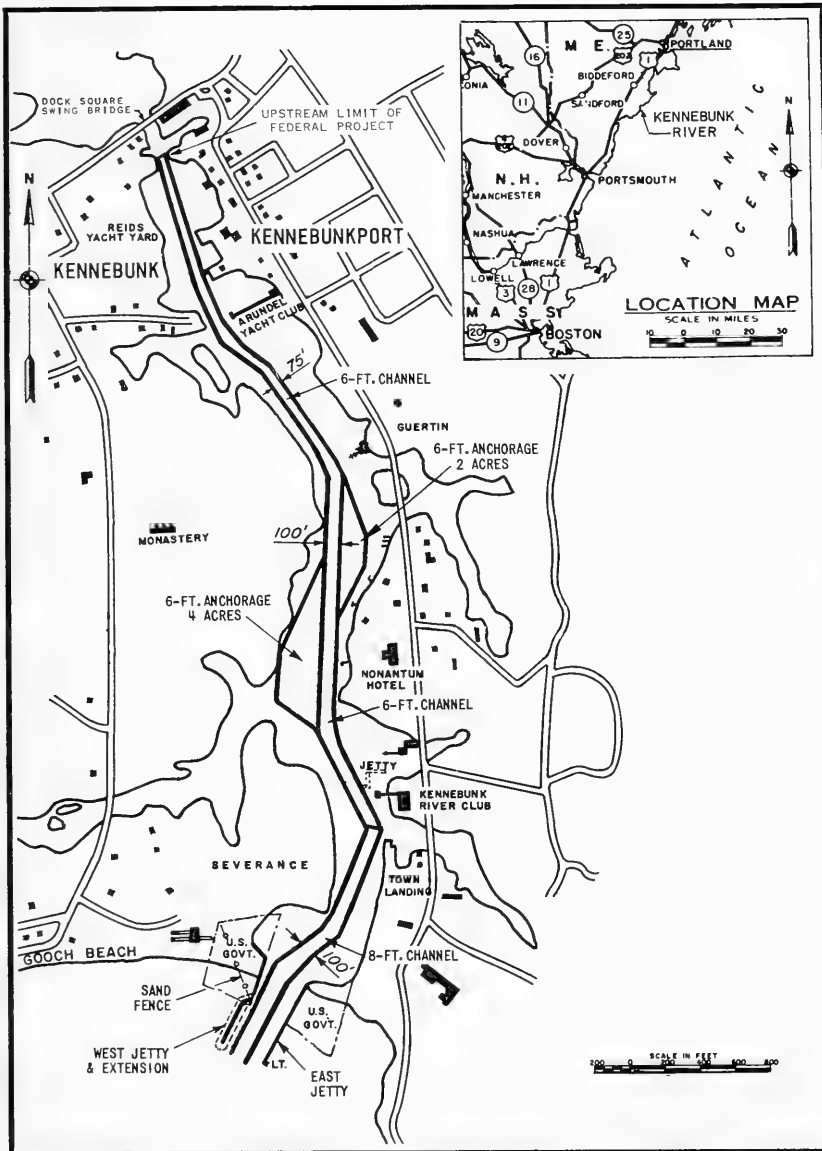

Figure 30. Kennebunk River Jetties, Maine

(Figure 31), which have an extensive repair and rehabilitation history, are showing considerable damage. This damage appears to result primarily from subsidence. Damage on four areas on the channel side of the south jetty most likely result from undermining of the rubble toe. The jetties at Hampton Harbor, New Hampshire (Figure 32), were originally constructed by the State and were turned over to the Corps in 1964. During 1965 to 1966, considerable work was done on both jetties. Since that time the south jetty has remained in good condition, while the north jetty has required continuous maintenance. Most of the repair and rehabilitation work has been needed on the seaward portions of the north jetty. The last rebuilding of the north jetty was completed in 1980, and it is thought that part of this recurring damage can be attributed to scour and undermining of the jetty toe.

North Central Division

29. There are 38 project sites within the Detroit District which have breakwater and/or pier (jetty) structures that have exhibited stability problems related to the structure toes. At 14 of these sites problems are associated with rubble-mound structures, while at the remaining 24 sites toe problems occur on other structure types. Table 2 is a listing of these 24 sites and the types of breakwater and/or jetty construction associated with each site. The remainder of this section on the Detroit District deals strictly with those 14 sites which are having and/or have had toe stability problems with rubble-mound structures. At some of these sites, toe stability problems have occurred on areas of the structures that are not rubble mound.

30. Structures at Black River Harbor, Cheboygan Harbor, Hammond Bay Harbor, Harrisville Harbor, New Buffalo Harbor, and Point Lookout Harbor, Michigan, are purely rubble-mound construction (Figures 33-40). Charlevoix Harbor, Michigan; Duluth-Superior Harbor, Minnesota and Wisconsin; and Leland Harbor, Muskegon Harbor, Pentwater Harbor, Port Washington Harbor, and Traverse City Harbor, Michigan (Figures 41-55), have structures that are composed of a combination of rubble mound, timber cribs, timber piles, steel sheet piles, concrete caissons, steel cells, concrete caps, and concrete superstructures. The head of the east jetty on the north end of the Keweenaw Waterway, Michigan (Figures 56 and 57), is an old timber crib which is encased in rubble. For this reason, its response is very similar to that of a purely

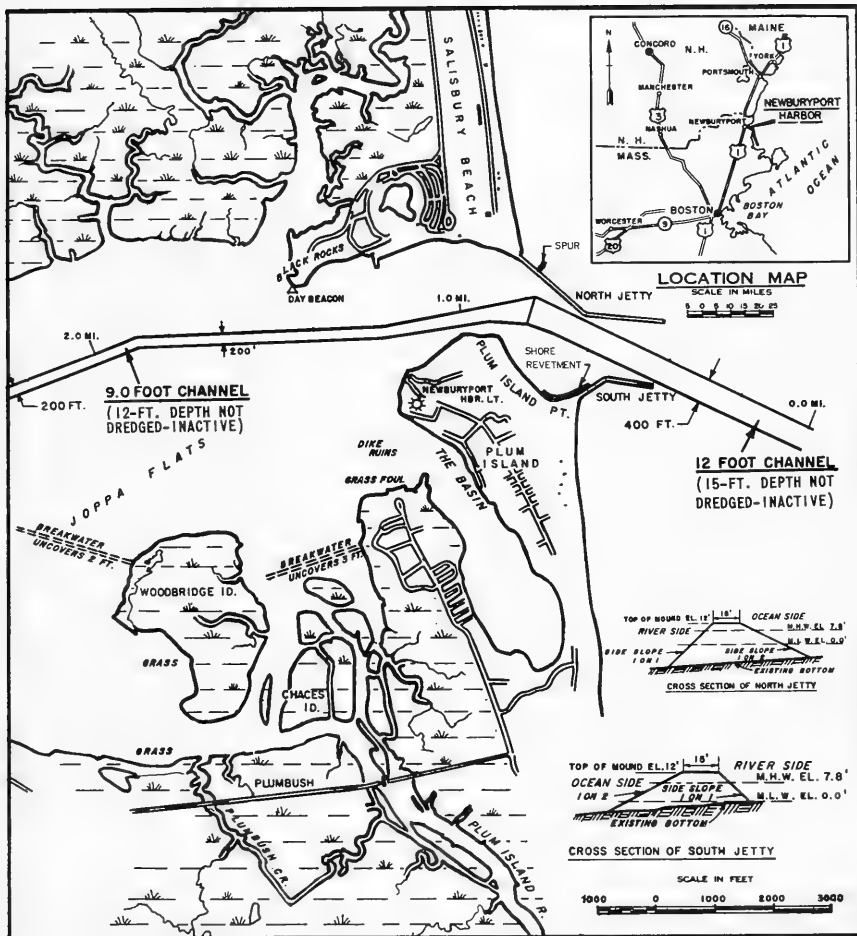

Figure 31. Newburyport Harbor Jetties, Massachusetts

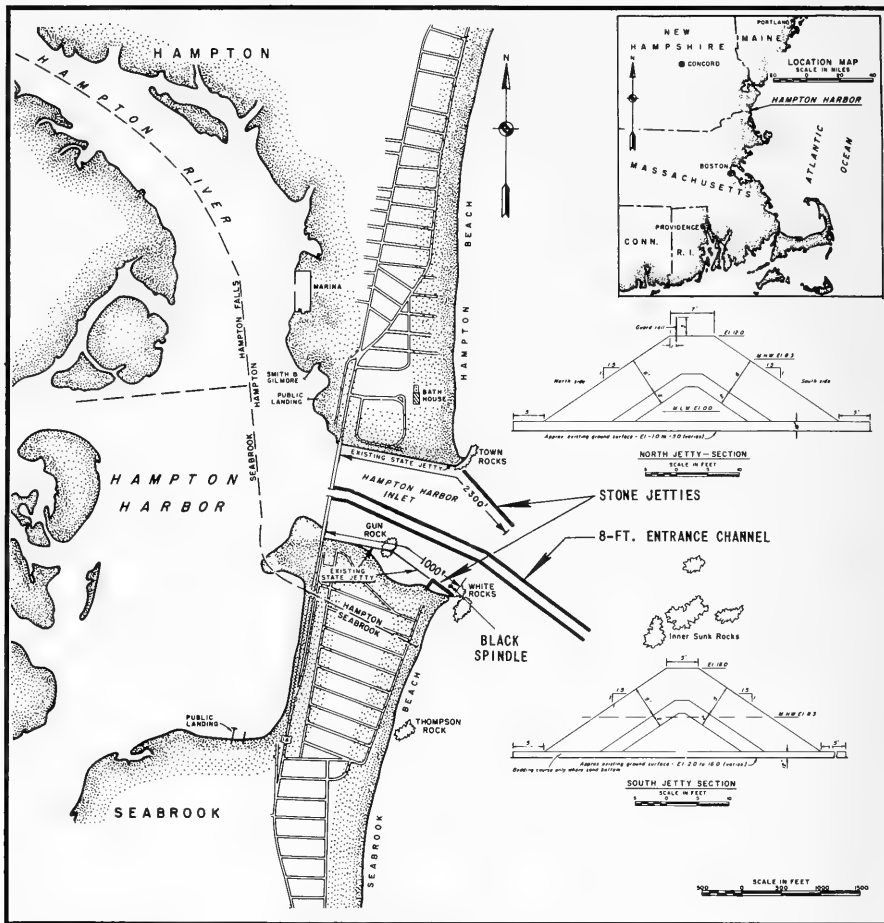

Figure 32. Hampton Harbor Jetties, New Hampshire

Table 2

Project Sites in Detroit District with Toe Stability Problems
on Other Than Rubble-Mound Structures

<u>Location</u>	<u>Types of Structures at Project Site*</u>
Algoma Harbor, Wisconsin	TP** and TC w/CS
Areadia Harbor, Michigan	SC and TC w/SSP
Big Bay Harbor, Michigan	RM, SC and SSP
Frankfort Harbor, Michigan	CC, TP, SP, SC, SSP, CS and CCP
Grand Haven Harbor, Michigan	SSP, TP, CS, and CCP
Harbor Beach, Michigan	TC and CS
Holland Harbor, Michigan	SSP, TC, RM, TP, CS and CCP
Kenosha Harbor, Michigan	TC, SSP, SC, CCP and CS
Kewaunee Harbor, Wisconsin	TP, CC, RM, SSP, SS, CCP and CS
Lac La Belle Harbor, Michigan	SC and SSP
Ludington Harbor, Michigan	TC, TP, SSP, RM, CCP and CS
Manistee Harbor, Michigan	SSP, TC, TP, and CS
Manitowoc Harbor, Wisconsin	TP, CC, TC, SSP, RM, and CS
Menominee Harbor, Michigan and Wisconsin	SSP, SC, CC, CCP and CS
Milwaukee Harbor, Wisconsin	TC, SSP, CC, RM, CCP and CS
Portage Lake Harbor, Wisconsin	TC, TP and CS
Racine Harbor, Wisconsin	TC, TP, RM, SSP, CC, CCP and CS
Saugatuck Harbor, Michigan	TC, TP, SSP, and CS
Sheboygan Harbor, Wisconsin	TC, TP, SSP, and CS
South Haven Harbor, Michigan	SSP, TC, CCP, and CS
St. Joseph Harbor, Michigan	TC, SSP, CCP and CS
Sturgeon Bay, Wisconsin	TP, TC, SSP, and CS
Two Rivers Harbor, Wisconsin	TP, TC, SSP and CS
White Lake Harbor, Michigan	TP, TC, and CS

* Not all structure types at each site are experiencing toe problems; however, tabulation presents all structure types existing at each site.

** TP-timber piles; TC-timber cribs; CS-concrete superstructure; SC-steel cells; SSP-steel sheet pile; RM-rubble mound; CC-concrete caisson; SP-steel piling; CCP-concrete cap; SS-steel sheeting

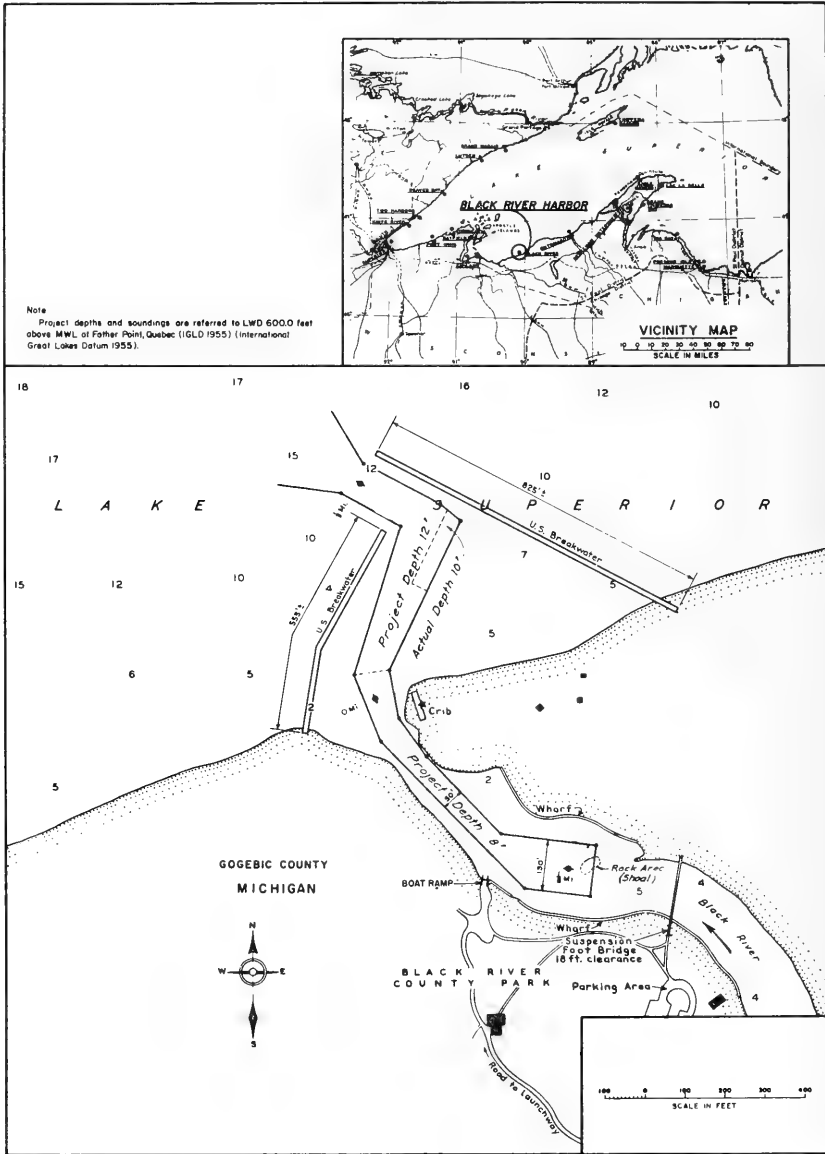
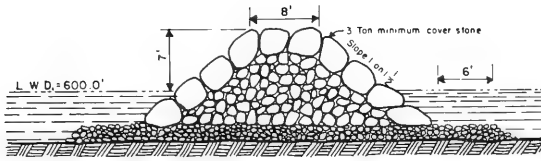
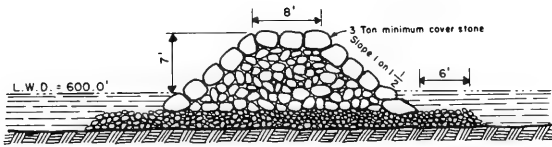

Figure 33. Black River Harbor Breakwaters, Michigan



Lakeward End to -5 Ft. Contour



-5 Ft. Contour to +2 Ft. Contour

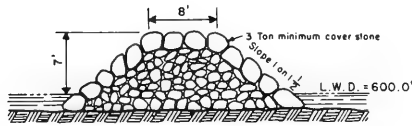
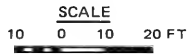

+2 Ft. Contour to Landward End

**RUBBLE MOUND - BUILT 1957
EAST AND WEST BREAKWATERS**

Total Lengths { East Breakwater - 825 Ft. ±
West Breakwater - 555 Ft. ±

Figure 34. Details of Black River Harbor Jetties, Michigan

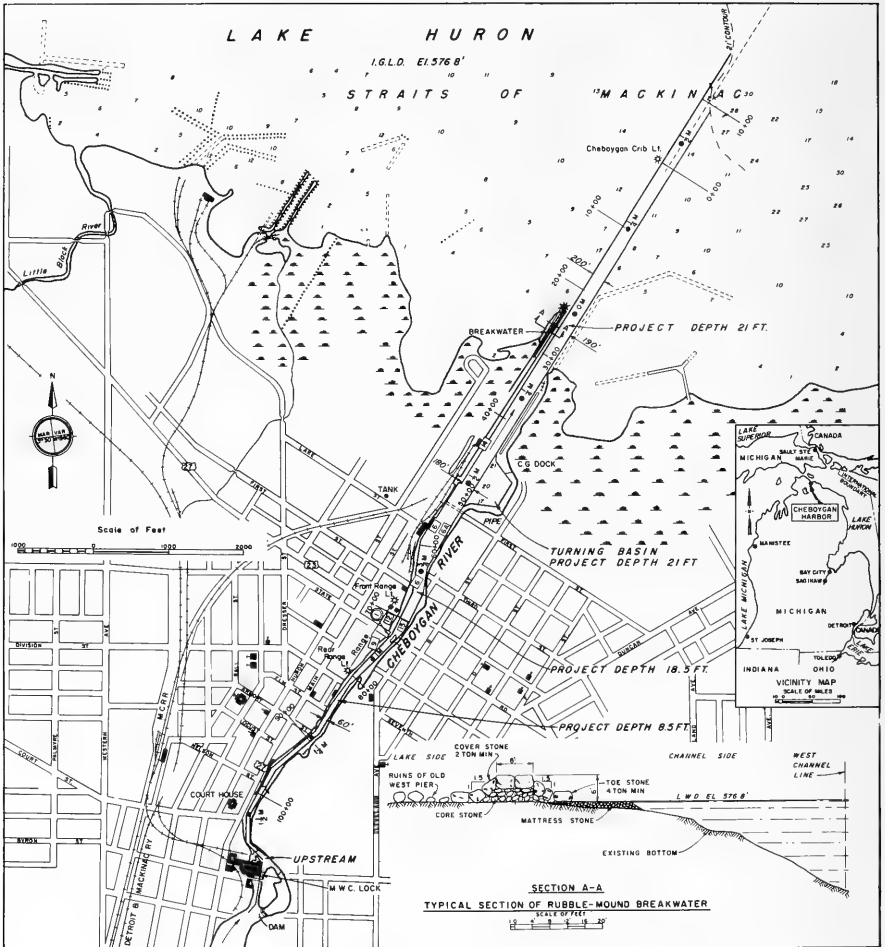

Figure 35. Cheboygan Harbor Breakwater, Michigan

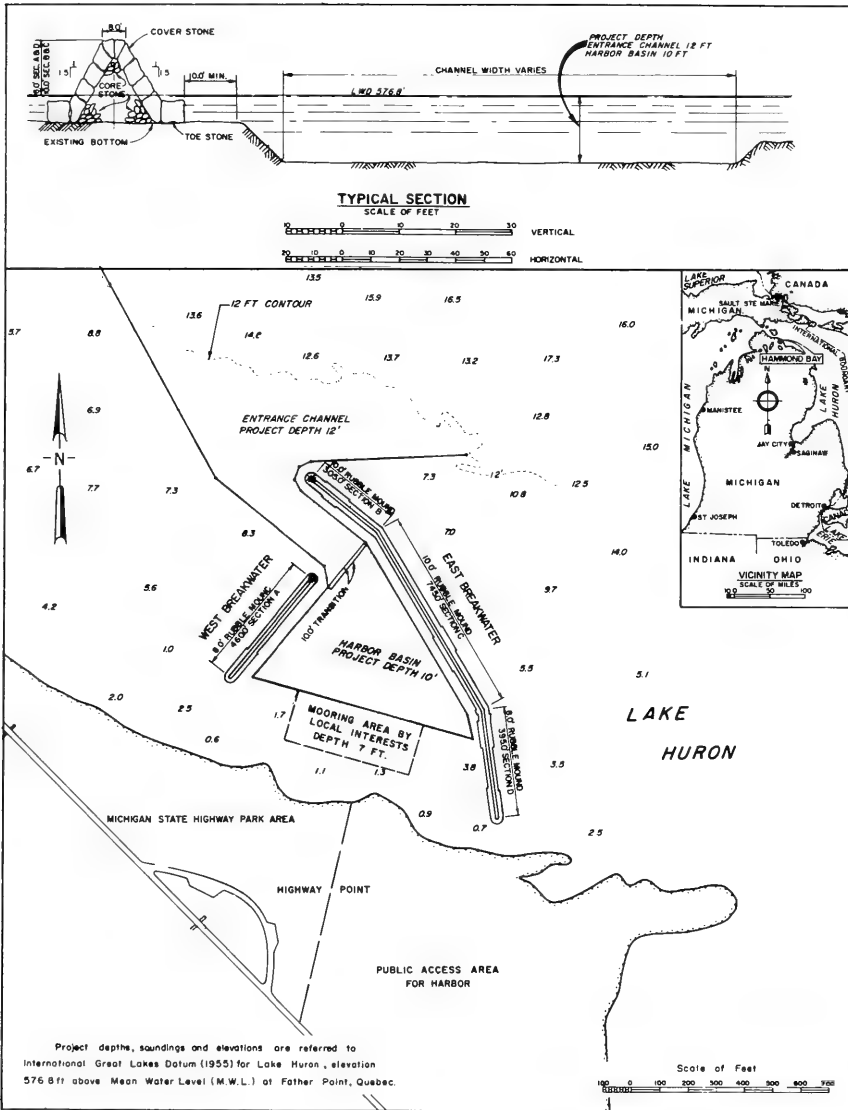

Figure 36. Hammond Bay Breakwater, Michigan

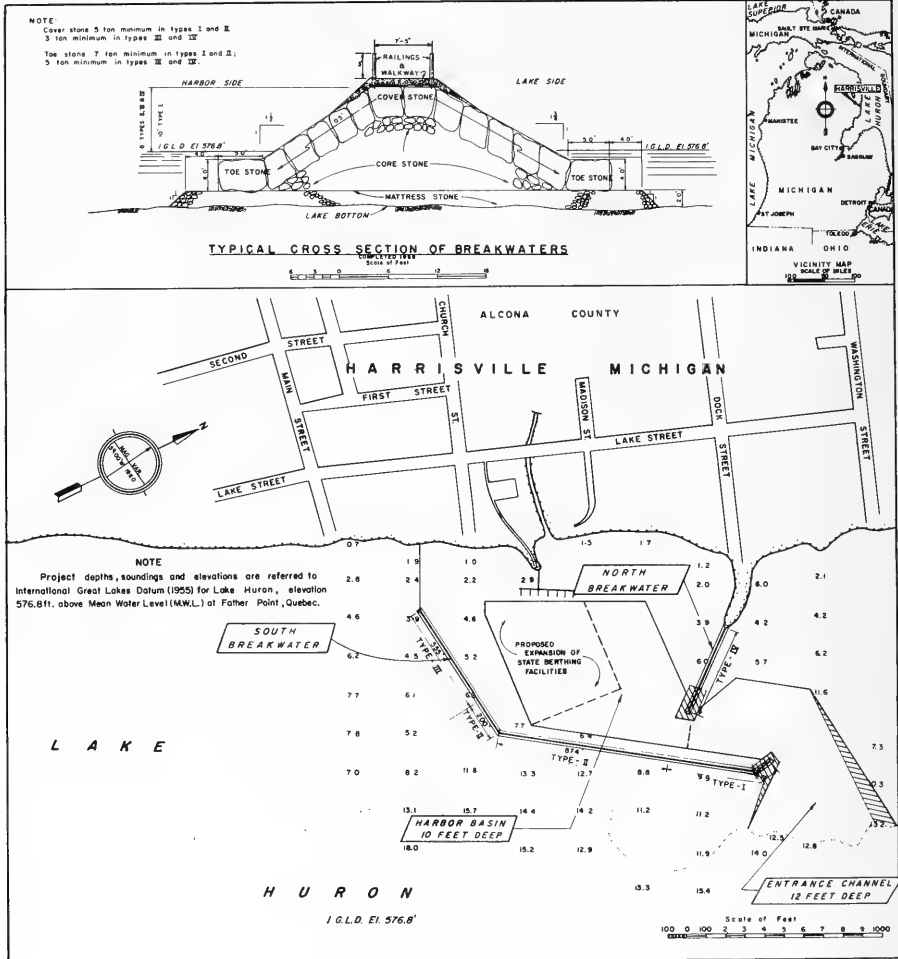

Figure 37. Harrisville Harbor Breakwaters, Michigan

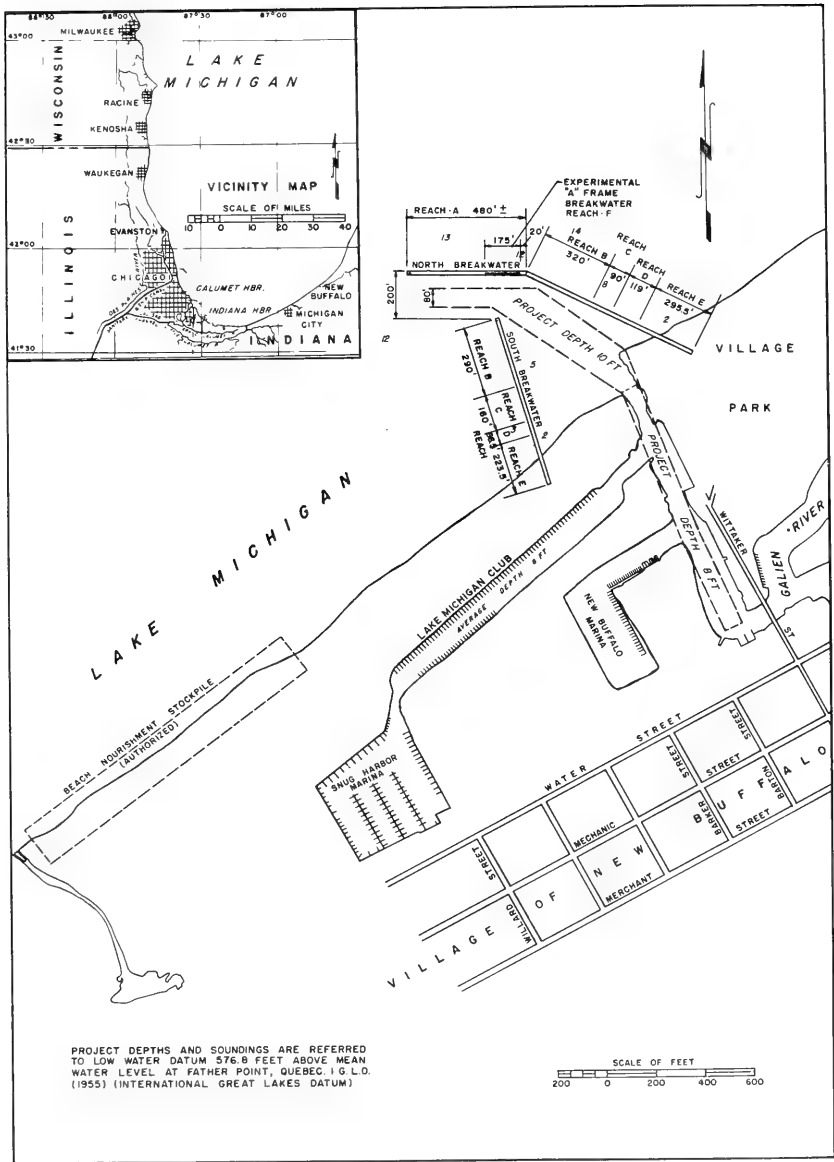
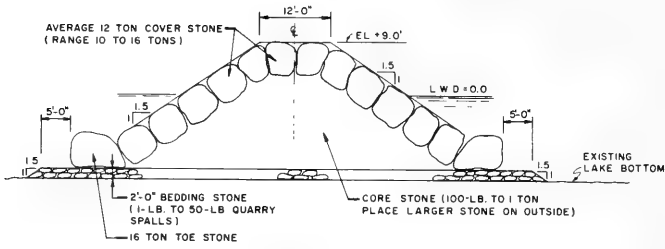
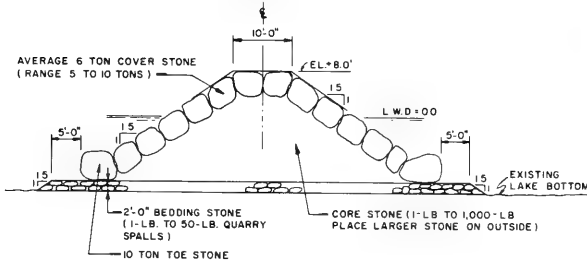

Figure 38. New Buffalo Harbor Breakwaters, Michigan



REACH-A
BUILT 1975



REACH-B
BUILT 1975

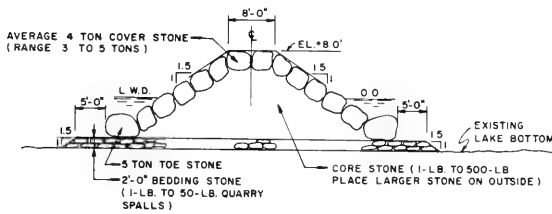

REACH-C
BUILT 1975

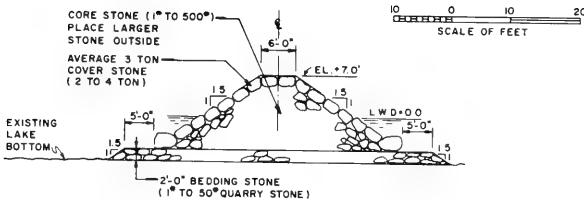

REACH-D
BUILT 1975

Figure 39. Details of New Buffalo Harbor Breakwaters, Michigan

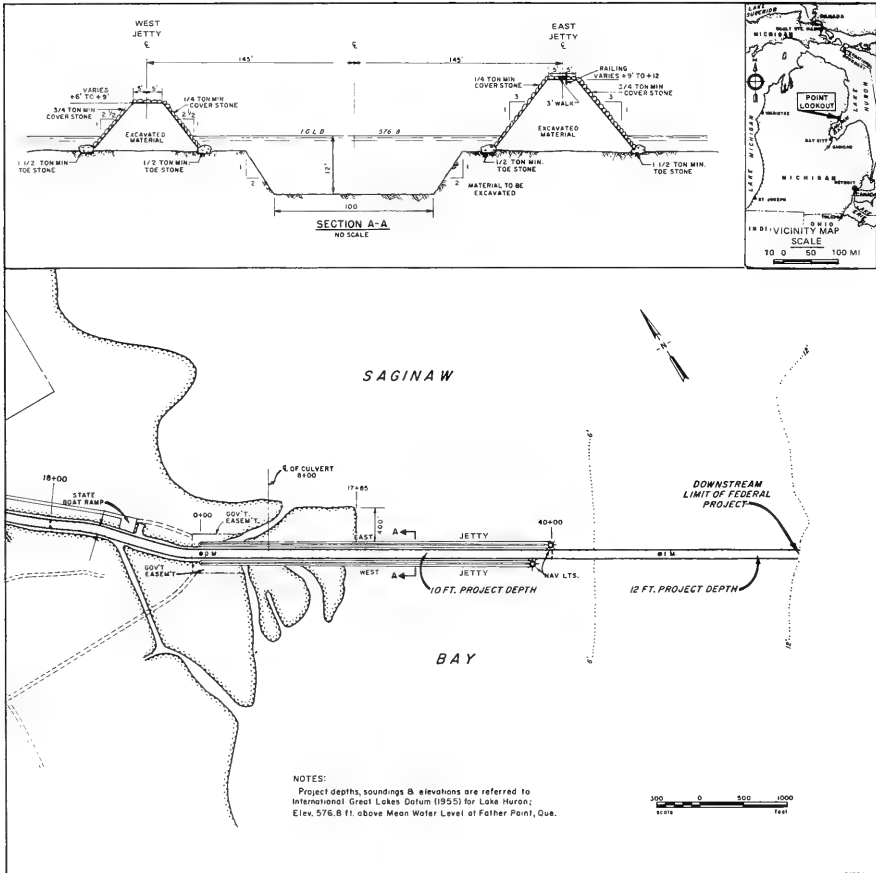

Figure 40. Point Lookout Harbor Jetties, Michigan

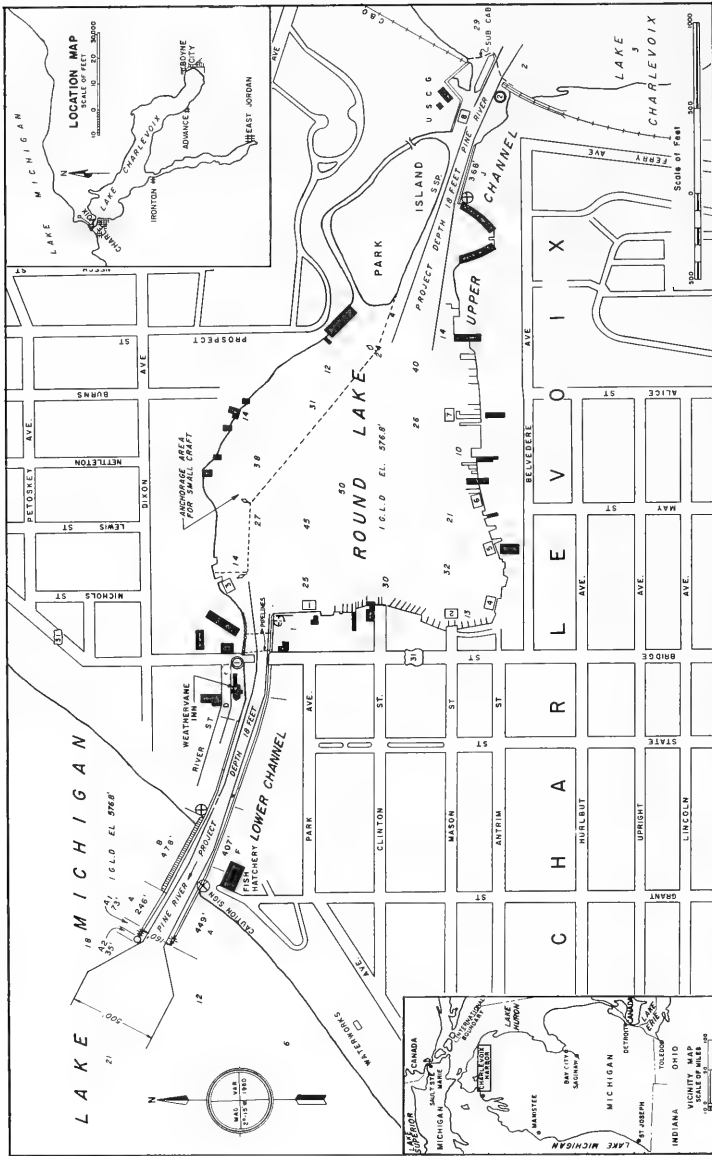

Figure 41. Charlevoix Harbor Jetties, Michigan

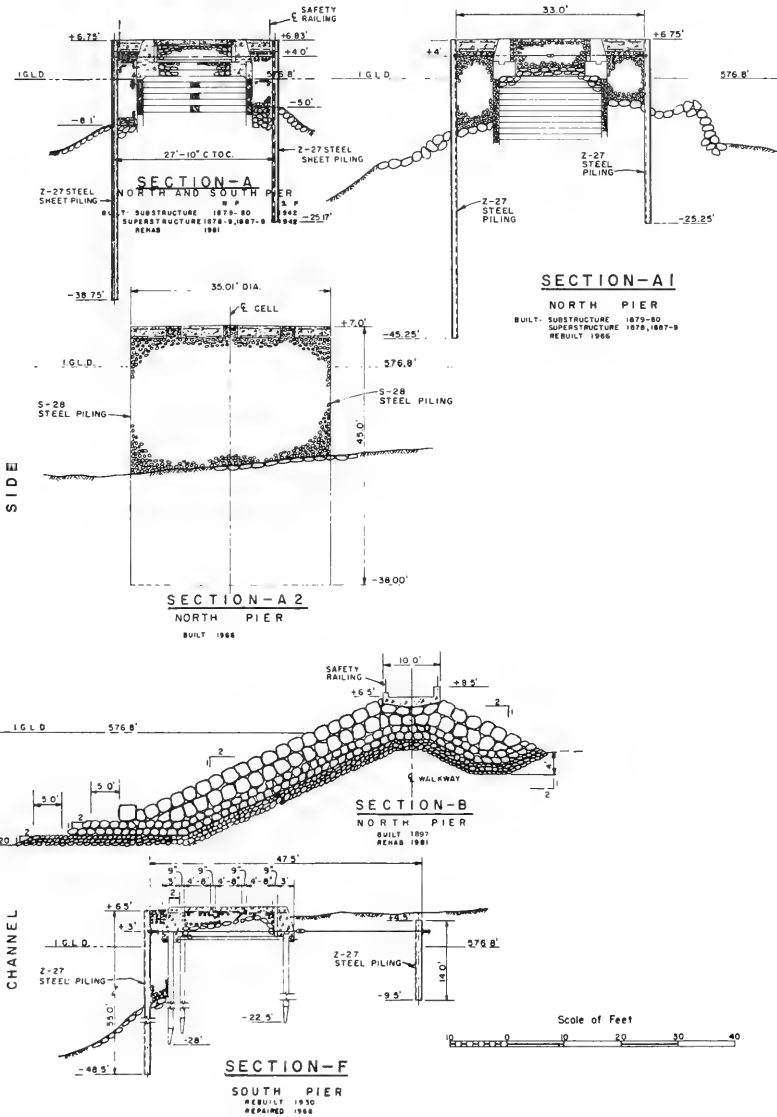

Figure 42. Details of Charlevoix Harbor Jetties, Michigan

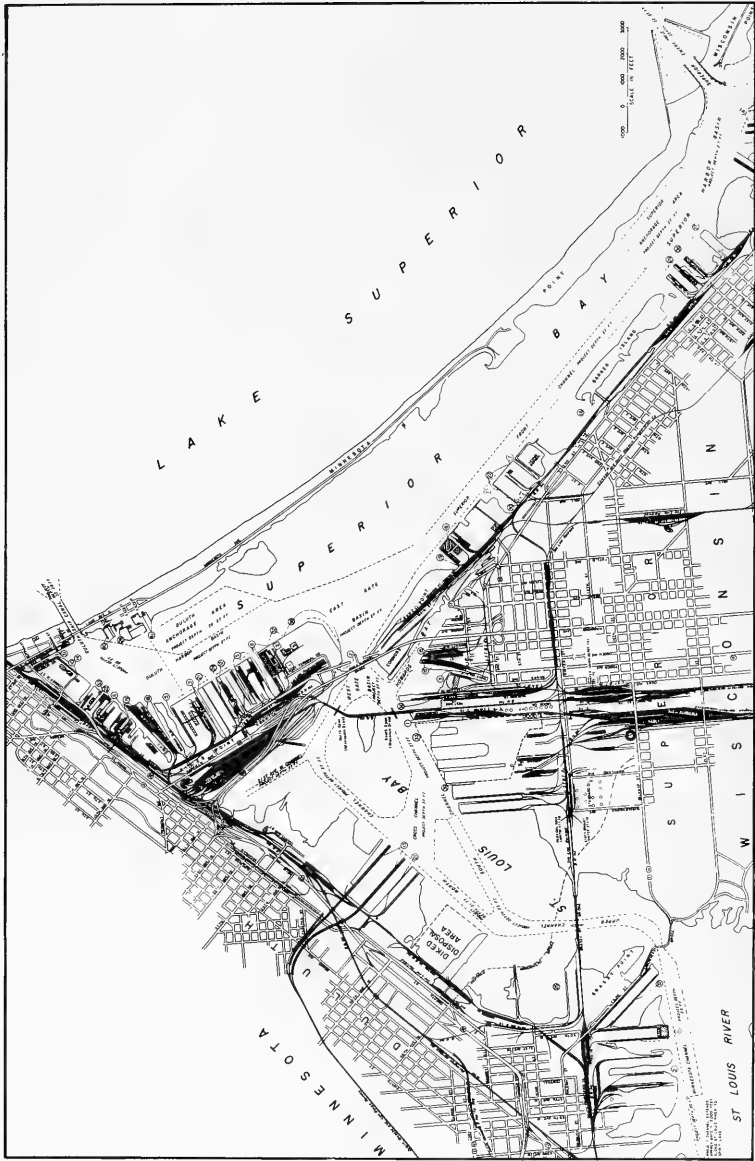
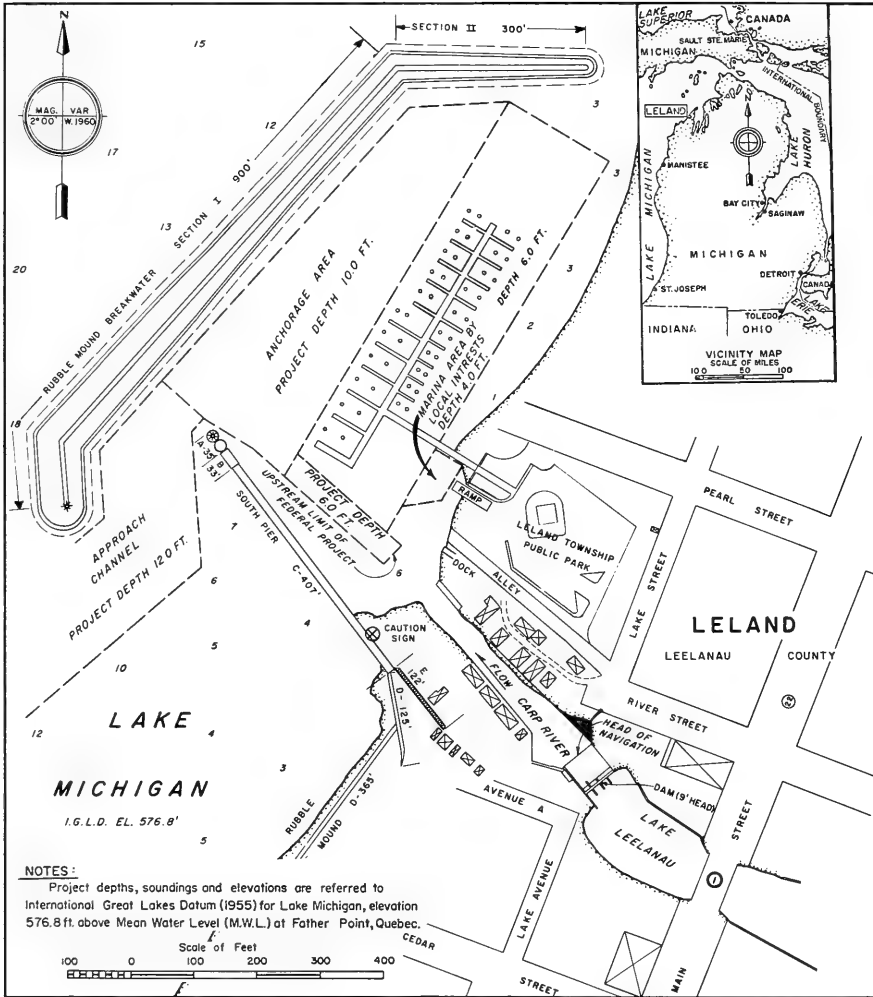
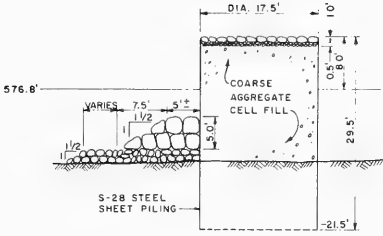

Figure 43. Duluth-Superior Harbor Jetties and Breakwaters, Minnesota and Wisconsin



SIDE



SECTION-A
CONSTRUCTED: 1968

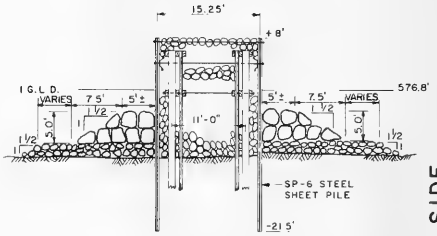

SECTION-B
BUILT: 1936
REPAIRED: 1952
REHABILITATED: 1966

SIDE

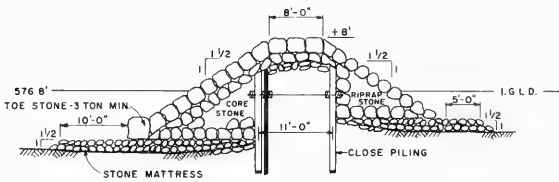

SECTION-C
BUILT: SUBSTRUCTURE 1936
CONSTRUCTED: 1968

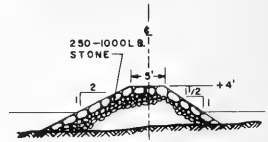

SECTION-D
RUBBLE MOUND
BUILT: 1941-3

LAKE

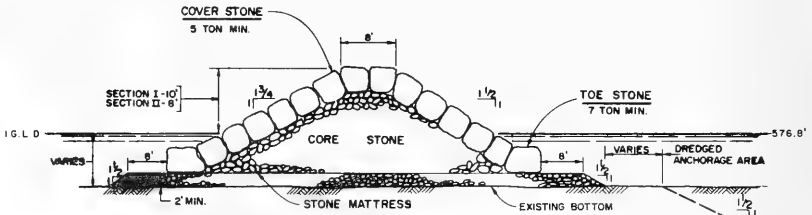

TYPICAL CROSS SECTION-RUBBLE MOUND BREAKWATER
CONSTRUCTED: 1968

HARBOR

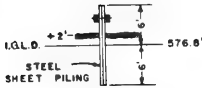

SECTION-E
SHORE CONNECTION
BUILT: 1948

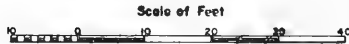

Figure 45. Details of Leland Harbor Breakwater and Jetty, Michigan

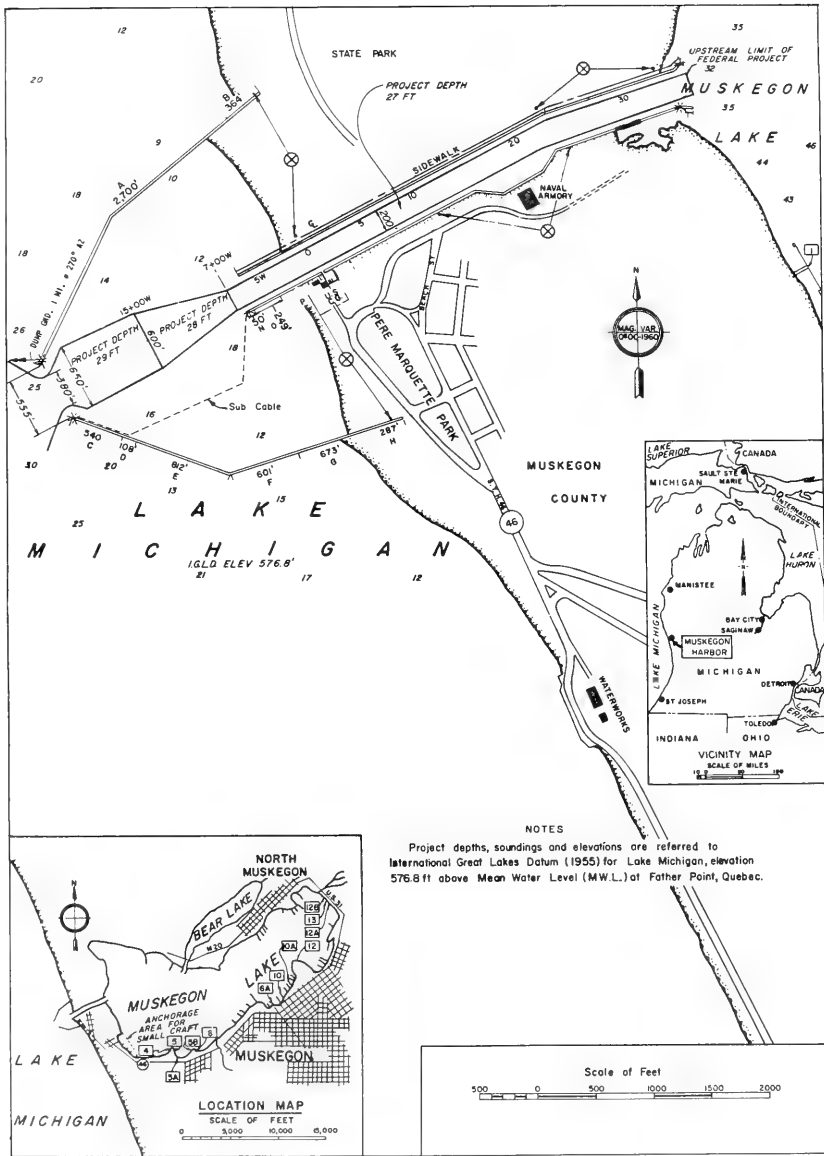

Figure 46. Muskegon Harbor Breakwaters and Jetties, Michigan

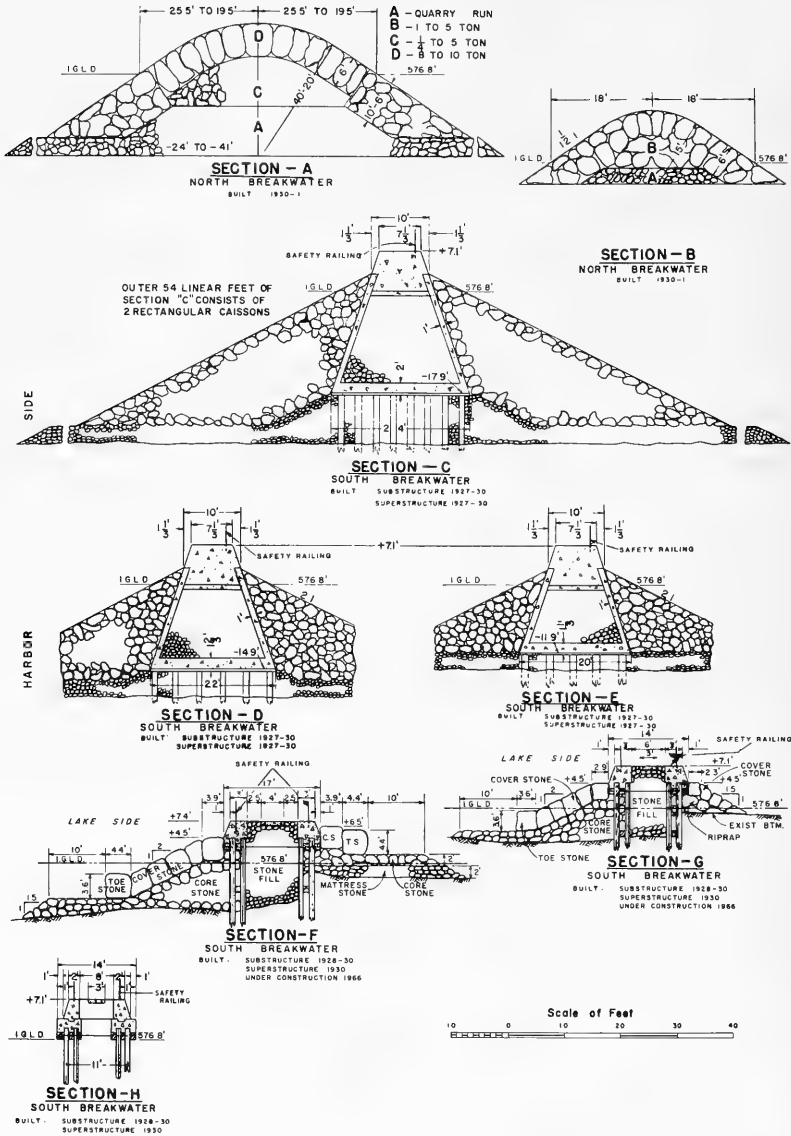

Figure 47. Details of Muskegon Harbor Breakwaters, Michigan

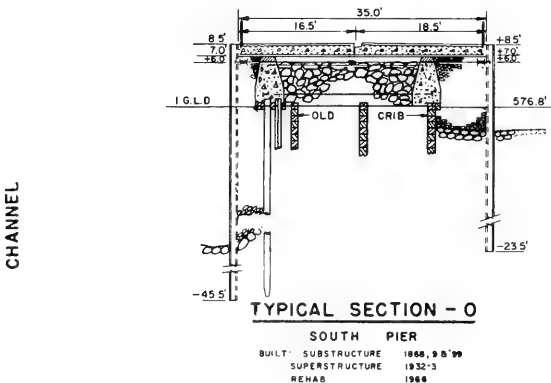
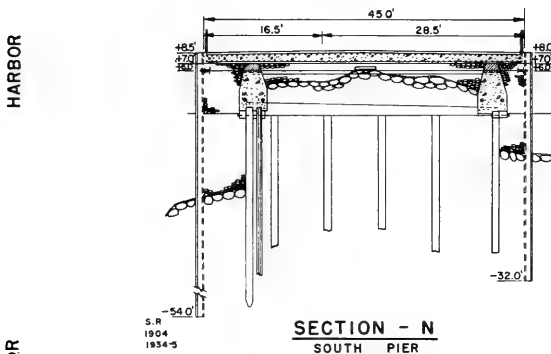
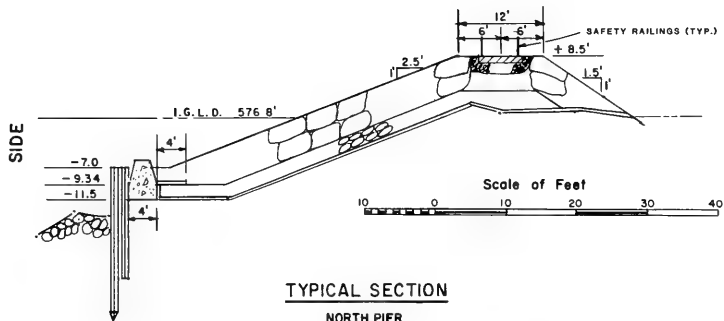

Figure 48. Details of Muskegon Harbor Jetties, Michigan

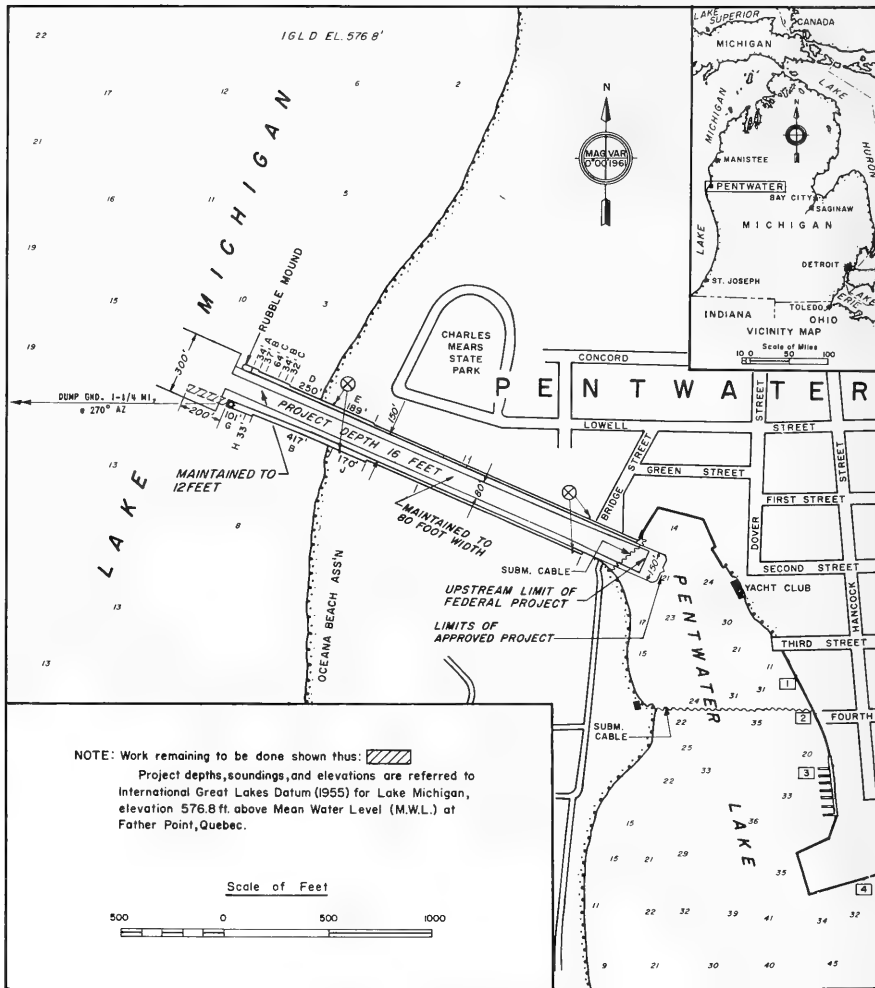

Figure 49. Pentwater Harbor Jetties, Michigan

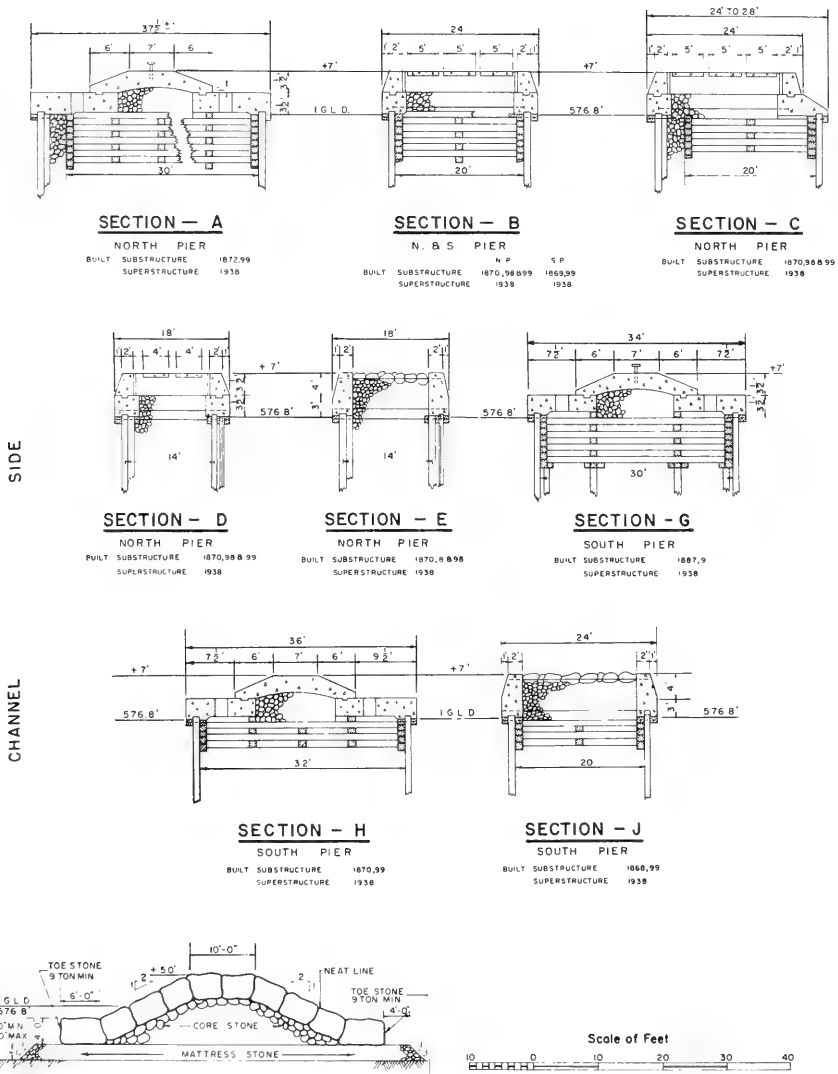
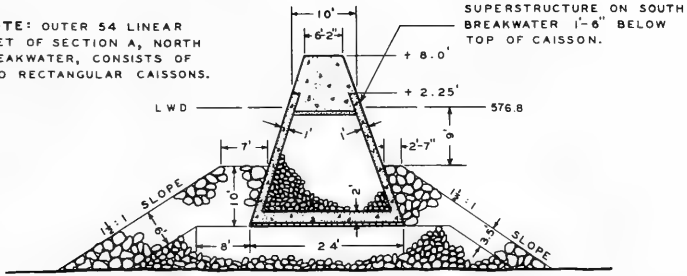

Figure 50. Details of Pentwater Harbor Jetties, Michigan

NOTE: OUTER 54 LINEAR FEET OF SECTION A, NORTH BREAKWATER, CONSISTS OF TWO RECTANGULAR CAISSONS.



SECTION-A

NORTH & SOUTH BREAKWATER

BUILT SUBSTRUCTURE N.B. 3B. 1934 1938
 SUPERSTRUCTURE 1934 1936

SIDE

HARBOR

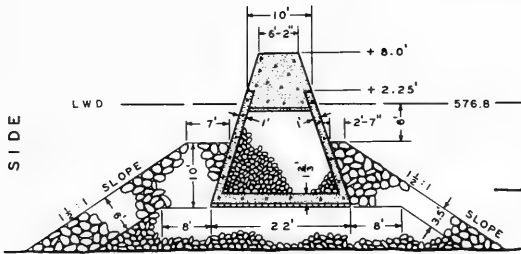

SECTION-B

NORTH BREAKWATER

BUILT SUBSTRUCTURE 1934
 SUPERSTRUCTURE 1934

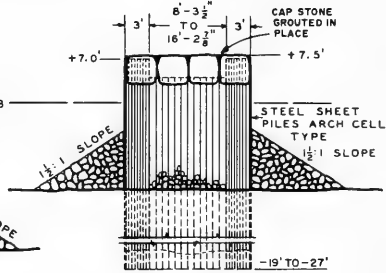

SECTION-D

NORTH BREAKWATER

BUILT: 1934

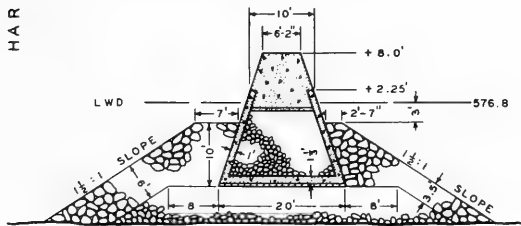

SECTION-C

NORTH BREAKWATER

BUILT SUBSTRUCTURE 1934
 SUPERSTRUCTURE 1934

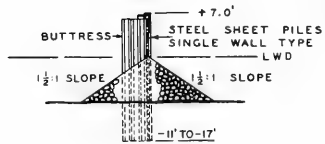

SECTION-E

NORTH SHORE CONNECTION

BUILT 1934

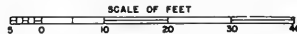
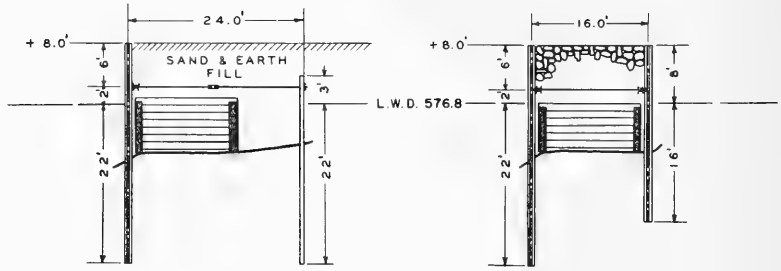

Figure 52. Details of Port Washington Harbor North and South Breakwaters, Wisconsin

CHANNEL OR HARBOR SIDE



SECTION-F
NORTH STUB PIER
BUILT: 1940

SECTION-G
NORTH STUB PIER
BUILT: 1940

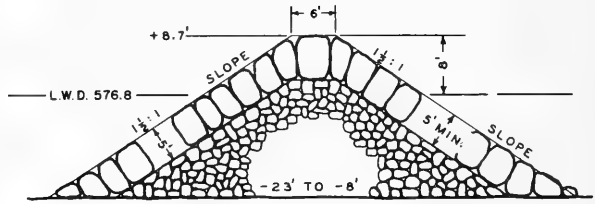

SECTION-I
WISCONSIN ELECTRIC POWER CO.

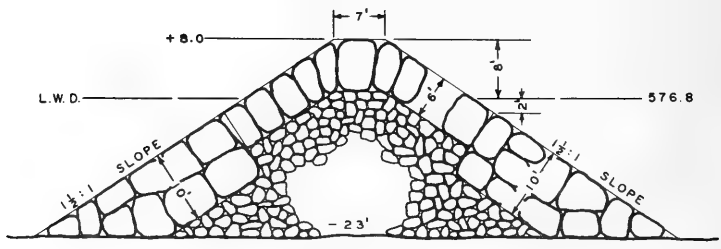

SECTION-J
SOUTH BREAKWATER
BUILT: 1936

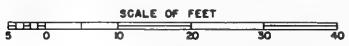

Figure 53. Details of Port Washington Harbor North Jetty and South Breakwater, Wisconsin

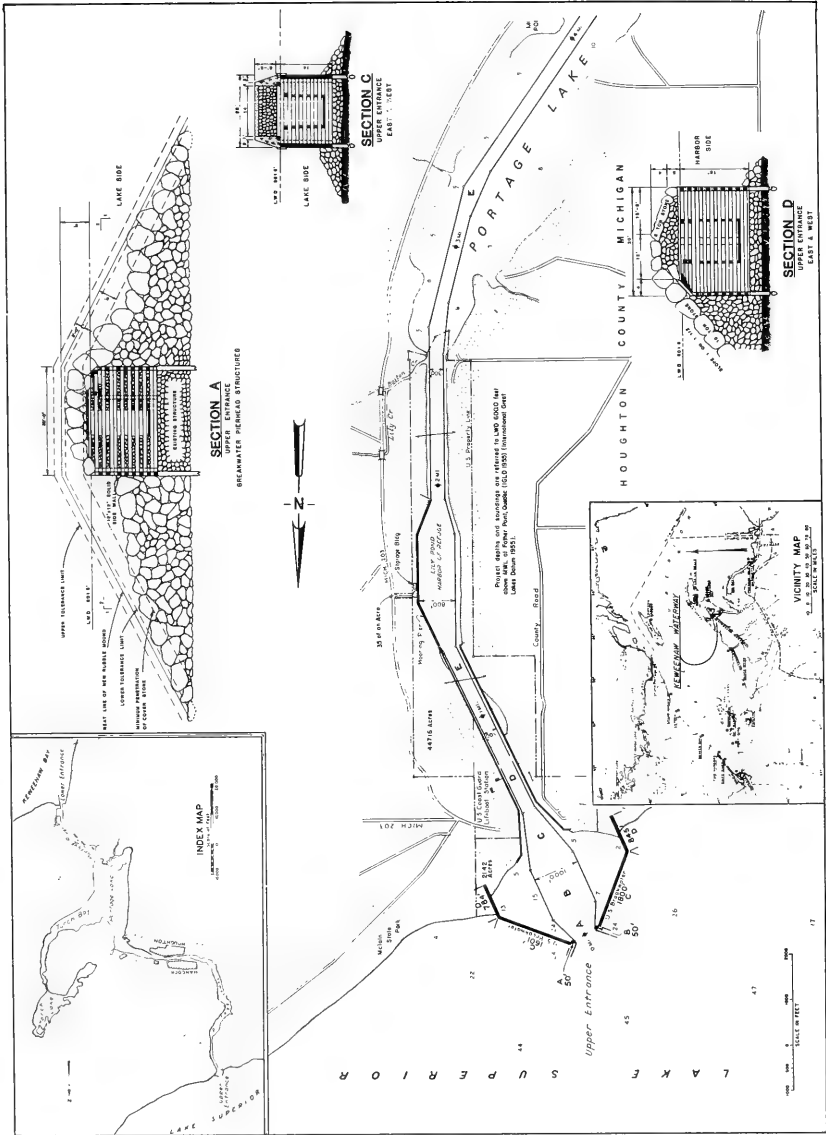

Figure 56. Upper Entrance Breakwaters, Keweenaw Waterway, Michigan

rubble-mound structure. The remainder of the structures at Keweenaw are timber crib with some rubble and steel sheet piles.

31. In general, the rubble-mound structures in the Detroit District that show toe stability problems have shown the results of this problem through damage to the upper slope and crown armor. It is not known definitely, but it is expected that the toe damage is a combination of toe armor instability combined with foundation scour and undermining of the structure toes. Repair to a structure is carried out by filling the scour holes with stone and then reshaping and repairing the structure's armor stone layer(s). Some repairs have been successful thus far, while other areas require frequent repair work.

PART III: DISCUSSION

32. In general, there appear to be three major problem areas with rubble-mound coastal structure toes. One of these pertains to the proper sizing and placement of toe buttressing stone. The purpose of the buttressing stone is to stabilize the onslope armor by preventing downslope slippage of the armor layer. For these stone to function properly, they must be of sufficient weight and placed in such a way that they are stable in a wave and/or flow environment. The second major problem area concerns toe berms. A toe berm's primary function is to protect a structure placed on an erodible bottom from being undermined by wave- and/or flow-induced scour and to resist downslope slippage of the armor. For a toe berm to function properly it, like the toe buttressing stone, must be composed of materials and be constructed in a geometry that will be stable in the incident wave and/or flow environment. Thirdly, toe buttressing stone and toe berms are susceptible to damage and failure when placed on an erodible bottom material. The stone may be sized adequately for the level of energy to which they are exposed, but the exposed bottom material at the outer perimeter of the structure may readily erode and/or an inadequately designed bedding material may allow the foundation material to migrate through it and the toe berm armor. Either one or both of these factors can result in the undermining and displacement of stone that were otherwise able to withstand the wave and flow environment but failed because of undermining induced displacement.

33. In summary, a toe failure may be the result of any one or a combination of the above. Guidance exists for proper design of bedding (filter) layers based on soil types, but very little guidance is available for the sizing and geometries needed for the proper design of toe berms and buttressing stone for incident wave environments. Most work done by the districts in these areas is based on field experience and engineering judgment. A scouring bottom is a problem in itself. No matter how well a toe is designed, if the local bottom materials (sands, silts, clays, etc.) are exposed to sufficient energy levels for scour to occur, the toe of the structure is doomed to failure unless the toe berm is extended out to a point where the energy levels are below those which will initiate scour. In most cases this is not practical or feasible. In these instances, sufficient toe berm material, that in itself is stable for the wave and/or flow environment must be placed so that as the

structure toe undermines, the berm material can slough off into the scour hole. This will provide some armoring to reduce the rate of scour and thus increase the usable, or functional, life of a structure.

PART IV: CONCLUSION

34. Based on extensive discussions with Corps division and district personnel and after the review of prototype experience relative to rubble-mound toe stability problems, it is concluded that design guidance is seriously needed on the proper sizing and placement configurations needed to provide adequate buttressing stone and toe berms for rubble-mound coastal breakwaters and jetties. Once it is understood how to design toe berms and buttressing stone for a range of water levels and wave conditions, these designs need to be incorporated into a test series that addresses the way in which varying toe geometries influence localized scour. The latter will provide some qualitative insight into how a toe berm can be configured or positioned to reduce the quantity and/or rate of localized foundation scour.

