

REESE LIBRARY
OF THE
UNIVERSITY OF CALIFORNIA.

Received , 190 .

Accession No. 92386 . *Class No.*

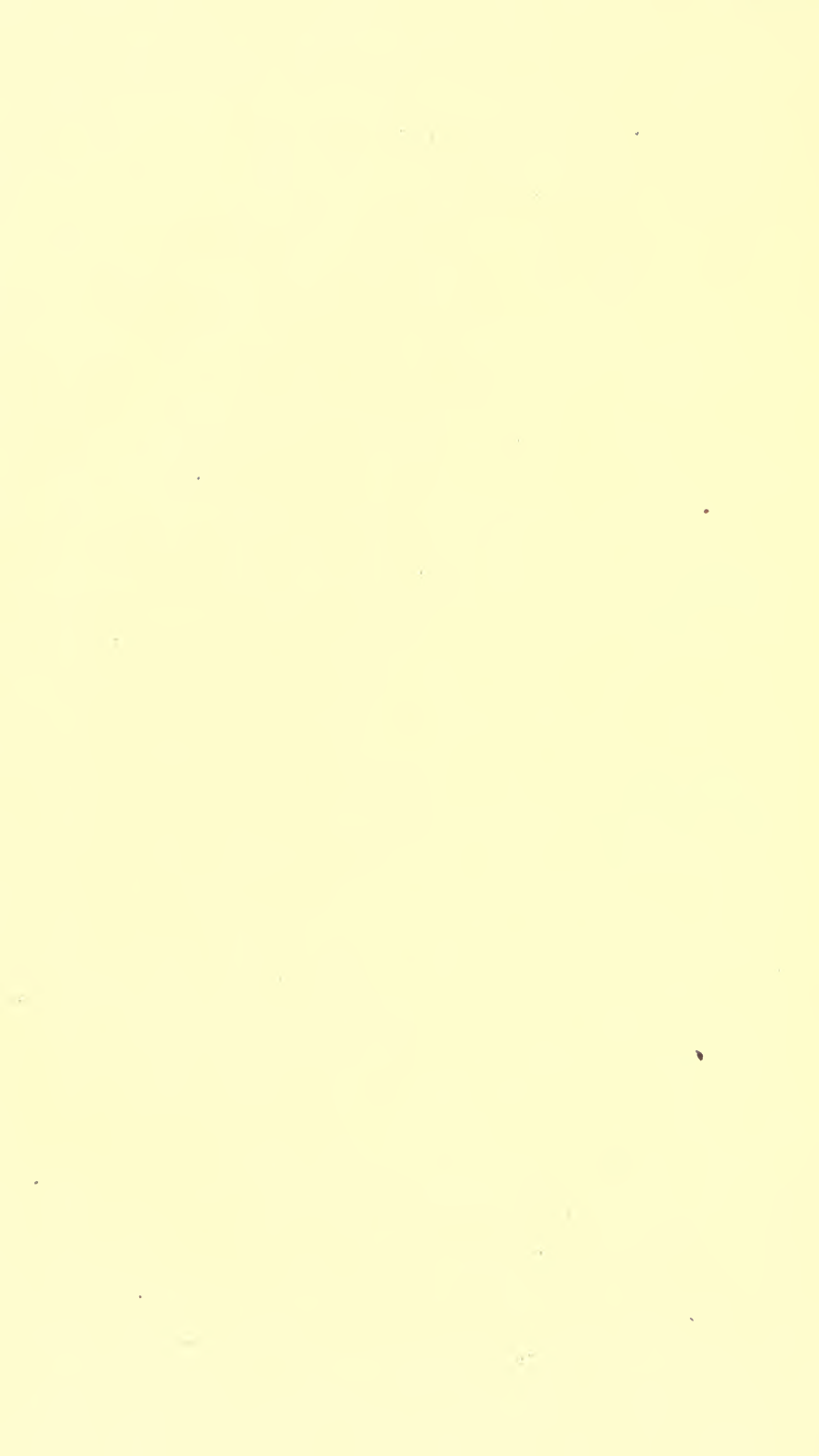

WORKS OF WILLIAM KENT

PUBLISHED BY

JOHN WILEY & SONS.

The Mechanical Engineers' Pocket-Book.

A Reference Book of Rules, Tables, Data, and Formulæ, for the Use of Engineers, Mechanics, and Students. xxxii + 1100 pages, 16mo, morocco, \$5.00.

Steam-Boiler Economy.

A Treatise on the Theory and Practice of Fuel Economy in the Operation of Steam-Boilers. xiv + 458 pages, 136 figures, 8vo, cloth, \$4.00.

STEAM-BOILER ECONOMY.

*A TREATISE ON THE THEORY AND
PRACTICE OF FUEL ECONOMY
IN THE OPERATION OF
STEAM-BOILERS.*

BY

WILLIAM KENT, A.M., M.E.,

*Consulting Engineer; Associate Editor of "Engineering News";
Author of "The Mechanical Engineer's Pocket Book";
Member American Society of Mechanical Engineers, American
Institute of Mining Engineers, American Society
of Heating and Ventilating Engineers.*

FIRST EDITION.

FIRST THOUSAND.



NEW YORK:

JOHN WILEY & SONS.

LONDON: CHAPMAN & HALL, LIMITED.

1901.

TJ 285
K3

Copyright, 1901,
BY
WILLIAM KENT.

PREFACE.

IN the year 1875 the author made his first evaporative test of a steam-boiler. It was the Pierce rotating boiler, which was tested at the Centennial Exhibition the following year. It had certain peculiarities of design which were supposed by the inventor to make it more efficient than any other boiler then on the market. The testing of this boiler and of two others during the same year led the author to study seriously the problem: "On what conditions does the fuel economy of a steam-boiler depend?" For three years, 1882-5, he was in the employ of the Babcock & Wilcox Co., and it was part of his work to make evaporative tests of the boilers made by that company, and of other kinds of boilers for comparison, in different sections of the country, and with all kinds of coal. In connection with his office practice from 1890 to the present time, he has had occasion to make nearly a hundred boiler-tests, with different boilers, fuels, and furnaces. Besides having this practical experience, together with the habit of studying critically the result of each test for the purpose of drawing conclusions from it, the author has been a constant student of the literature of the subjects of boiler-testing and fuel economy, which from time to time appears in the transactions of engineering societies, in the technical press, in trade catalogues, and in books. He has thus been enabled to compare theory with practice.

Many books have been written on the subjects of boilers, furnaces, and fuels, but in none of them does it seem that the problem of steam-boiler economy has been treated with the thoroughness which its importance deserves. Most of the treatises on boilers devote the greater part of their space to details of construction, and only a small space to the subject of fuel economy. There appears to be a demand for a new book which shall treat solely of steam-boiler economy and of subjects related thereto. To supply such a demand this book is offered.

A few words as to the plan and scope of the book. The first chapter contains a statement of principles and definitions and a very brief survey of the whole ground intended to be covered in the remainder of the book. Chapter II treats of the chemistry of fuel and of combustion, of the heat generated by combustion, and of the temperatures produced under different conditions. The discussion of the subject of temperature is believed to be more complete than that given in any other work. Chapter III is a brief one on coal and its heating value, including a table of analyses and heating values of American coals. Chapter IV is much longer, and is a condensed treatise on the coal-fields of the United States, giving their location, with the analyses of the coals mined in each State or district. The space given to this subject is believed to be justified by the close relation which exists between the economy of a boiler and the quality of coal used in it. Chapter V is a discussion of tests of the heating values of American and foreign coals, and shows the relation of the heating value to both the proximate and the ultimate analysis. It reviews the work of Johnson and of Lord & Haas on American coals, and of Scheurer-Kestner, Mahler, and Bunte, on foreign coals. Chapter VI treats of fuels other than coal, including peat, oil, gas, bagasse, etc. Chapter VII treats of furnaces, methods of firing, smoke-prevention, mechanical stokers, and forced draft.

In Chapter VIII the discussion of the boiler itself, and of the efficiency of its heating surface, begins. The plain cylinder boiler is taken as the simplest form, and in an elementary manner it is shown how the fuel economy depends on the rate of driving as well as on other conditions. In Chapter IX the same subject is considered further by the mathematical method. There is here published for the first time a formula for efficiency of heating surface which contains all the variables affecting the problem that are measurable. They are: heating value of the fuel, temperature of the water in the boiler, radiation, weight of chimney-gas per pound of combustible, and rate of driving. It contains only one coefficient of performance, "*a*," which is not measurable as a concrete quantity, but is a figure that may be derived from the results of boiler-tests, and is useful in comparing one test with another. Much of this chapter will be skipped by those who are not accustomed to the use of algebraic formulæ, but the conclusions which follow the mathematical treatment are of great importance, and should not be neglected.

Chapter X illustrates and briefly describes the various types of

steam-boilers now on the market, and shows the evolution of many of them from earlier forms. Chapter XI discusses boiler horse-power, proportions of grate and heating surface, and boiler performance. Chapter XII treats of the "points" of a good boiler, and will be found useful to those who are contemplating the purchase of a steam-boiler. Chapter XIII discusses "boiler-troubles and boiler-users' complaints," and contains much information that should be serviceable to boiler-users. Chapter XIV treats of boiler-testing, and includes the "Code of 1899" adopted by the boiler-test committee of the American Society of Mechanical Engineers, of which committee the author was a member. Chapter XV gives the results of several boiler-tests, together with conclusions drawn from them. Chapter XVI gives tables of properties of water and of steam, factors of evaporation, and a brief discussion of chimneys, with the author's table of chimney proportions. Chapter XVII is a miscellaneous assortment of subjects relating to boiler economy which were not included in previous chapters.



CONTENTS.

CHAPTER I.

PRINCIPLES AND DEFINITIONS.

| | PAGE |
|--|------|
| List of Subjects to be studied..... | 1 |
| Heat | 2 |
| Temperature..... | 2 |
| Heat-unit..... | 3 |
| Unit of Evaporation..... | 4 |
| Latent Heat..... | 4 |
| Specific Heat..... | 5 |
| Quantity of Heat..... | 6 |
| Heat of Combustion..... | 7 |
| How Smoke may be burned..... | 8 |
| Flame..... | 9 |
| Transfer of Heat..... | 10 |
| Capacity of a Boiler..... | 10 |
| Boiler Horse-power..... | 11 |
| Efficiency of a Boiler..... | 11 |
| Operation of a Boiler..... | 12 |
| Efficiency of the Heating Surface..... | 14 |

CHAPTER II.

FUEL AND COMBUSTION.

| | |
|--|----|
| Chemistry of Fuel and Combustion..... | 16 |
| Carbon..... | 16 |
| Hydrogen..... | 16 |
| Oxygen..... | 17 |
| Nitrogen..... | 17 |
| Sulphur..... | 17 |
| Properties of Air..... | 18 |
| Relative Humidity..... | 18 |
| Weights of Air, Vapor of Water, etc..... | 19 |
| Heat absorbed by Decomposition..... | 21 |

| | PAGE |
|--|------|
| Heating Value of Compound or Mixed Fuels..... | 21 |
| Available Heating Value of Hydrogen..... | 22 |
| Available Heating Value of a Fuel containing Hydrogen..... | 23 |
| Temperature of the Fire..... | 25 |
| Maximum Temperature due to burning Carbon..... | 26 |
| " " " " " Hydrogen..... | 27 |
| Temperature of the Fire, Fuel containing Hydrogen and Water..... | 28 |
| Excessive Carbon Monoxide due to Heavy Firing..... | 31 |
| Calculation of Weight of Air Supplied..... | 32 |
| Heating Value of Sulphur in Coal..... | 35 |
| Hygrometric Properties of Coal..... | 36 |

CHAPTER III.

COAL.

| | |
|--|----|
| Coal and Social Progress..... | 38 |
| Production of Coal in the United States..... | 39 |
| Formation of Coal..... | 39 |
| Progressive Change from Wood to Graphite..... | 41 |
| Classification of Coal..... | 42 |
| Caking and Non-caking Coals..... | 43 |
| Long-flaming and Short-flaming Coals..... | 43 |
| Cannel Coals..... | 43 |
| Lignite or Brown Coal..... | 43 |
| Proximate Analyses and Heating Value of Coals..... | 46 |
| Approximate Heating Values of Coals..... | 49 |
| Relation of Quality of Coal to Capacity and Economy of a Boiler..... | 50 |
| Valuing Coals by Test and by Analysis..... | 51 |

CHAPTER IV.

COAL-FIELDS OF THE UNITED STATES.

| | |
|--|------------------|
| Maps of Coal-fields of the United States..... | <i>Facing</i> 52 |
| Graphitic Coal in Rhode Island and Massachusetts..... | 52 |
| Anthracite Coal-beds of Pennsylvania..... | 53 |
| Semi-anthracite in Sullivan Co., Pa..... | 54 |
| Progression from Bituminous to Anthracite..... | 54 |
| Early Use of Pennsylvania Anthracite..... | 54 |
| Virginia Anthracite..... | 55 |
| Anthracite in Colorado..... | 55 |
| Anthracite in New Mexico..... | 56 |
| Bituminous and Semi-bituminous Coal-fields..... | 56 |
| Appalachian Field in Pennsylvania..... | 57 |
| Analyses of Pennsylvania Bituminous and Semi-bituminous Coals..... | 59 |
| Maryland Semi-bituminous Coal..... | 62 |
| Virginia..... | 63 |
| North Carolina..... | 64 |

| | PAGE |
|--|------|
| West Virginia..... | 64 |
| Eastern Kentucky..... | 65 |
| Tennessee..... | 66 |
| Georgia, Alabama, Ohio..... | 67 |
| Northern or Michigan Coal-field..... | 68 |
| The Illinois Coal-basin..... | 69 |
| Indiana, Western Kentucky..... | 69 |
| Illinois..... | 70 |
| The Missouri Coal-basin..... | 74 |
| Iowa..... | 74 |
| Kansas..... | 75 |
| Arkansas..... | 76 |
| Indian Territory..... | 77 |
| Texas, Colorado..... | 78 |
| Lignites and Lignitic Coals of the Western States..... | 79 |
| Wyoming, New Mexico, Arizona, Utah..... | 80 |
| Montana, North Dakota, Nevada, California..... | 81 |
| Oregon, Washington..... | 82 |
| Alaska..... | 83 |

CHAPTER V.

TESTS OF THE HEATING VALUE OF AMERICAN AND FOREIGN COALS.

| | |
|--|-----|
| Johnson's Tests of American Coals..... | 84 |
| Scheurer-Kestner's Tests of European Coals..... | 84 |
| Gruner's Classes of Coals..... | 87 |
| Comparison of Theoretical and Industrial Heating Power of Coals..... | 88 |
| Remarks on Scheurer-Kestner's Tests..... | 89 |
| Mahler's Tests of European Coals..... | 92 |
| Mahler's Bomb-calorimeter..... | 94 |
| Lord and Haas's Tests of American Coals..... | 101 |
| Comparison of Mahler's and Lord and Haas's Results..... | 110 |
| Heating Value of Wyoming Coals..... | 111 |
| Calorific Power of Weathered Coals..... | 113 |
| Weathering of Coal..... | 116 |
| Composition and Heating Value of German Coals..... | 116 |
| Selection of Coal for Steam-boilers..... | 119 |
| Appearances for Determining Heating Value of Coals..... | 121 |
| Comparative Calorimetric Tests of Coals..... | 126 |
| Testing the Relative Value of Different Coals..... | 128 |

CHAPTER VI.

FUELS OTHER THAN COAL.

| | |
|---------------------------------|-----|
| Coke..... | 131 |
| Pressed Fuel or Briquettes..... | 131 |
| Coal-dust..... | 132 |

| | PAGE |
|--------------------------------------|------|
| Peat or Turf | 133 |
| Wood | 134 |
| Sawdust | 135 |
| Tan-bark | 136 |
| Straw | 136 |
| Bagasse | 137 |
| Petroleum | 137 |
| Oil <i>versus</i> Coal as Fuel | 141 |
| Gas Fuel | 142 |
| Corn as Fuel | 144 |

CHAPTER VII.

FURNACES.—METHODS OF FIRING.—SMOKE-PREVENTION.—MECHANICAL STOKERS.
FORCED DRAFT.

| | |
|--|-----|
| Location of the Furnace | 145 |
| Requirements of a Good Furnace | 146 |
| Burning of Anthracite Coal | 147 |
| Burning Small Sizes of Anthracite | 148 |
| Comparative Efficiency of Steam- and Fan-blowers | 150 |
| Grate-bars | 151 |
| Shaking- and Dumping-grates | 153 |
| The McClave Grate | 153 |
| The Argand Steam-blower | 154 |
| How to Burn Soft Coal | 155 |
| How to Avoid Smoke | 156 |
| Practical Success of Smoke-prevention | 157 |
| Requirements of a Smoke-preventing Furnace | 158 |
| The Coking System of Firing | 159 |
| The Walker Furnace | 160 |
| Alternate Firing | 161 |
| The "Wing-wall" Furnace | 162 |
| Introduction of Heated Air into the Furnace | 163 |
| Downward-draft Furnaces | 165 |
| Automatic or Mechanical Stokers | 166 |
| The Vicars Stoker | 169 |
| The Coxe Stoker | 170 |
| The Playford Stoker | 171 |
| The Babcock & Wilcox Stoker | 171 |
| The Roney Stoker | 173 |
| The Acme Stoker | 174 |
| The Wilkinson Stoker | 176 |
| The Murphy Furnace | 176 |
| The American Stoker | 177 |
| The Jones Under-feed Stoker | 179 |
| Forced Draft | 179 |
| The Howden Hot-air System | 181 |

| | PAGE |
|---------------------------------------|------|
| Retarders..... | 181 |
| The Ellis & Eaves Hot-air System..... | 182 |
| Furnaces for Burning Coal-dust..... | 184 |
| Methods of Burning Petroleum..... | 184 |
| Bagasse Burner..... | 187 |

CHAPTER VIII.

SOME ELEMENTARY PRINCIPLES OF BOILER ECONOMY AND CAPACITY. — THE
PLAIN CYLINDER BOILER.

| | |
|---|-----|
| Capacity of a Plain Cylinder Boiler..... | 188 |
| Calculations of Fuel Economy..... | 191 |
| Capacity Depends on Economy..... | 192 |
| Loss of Economy due to Insufficient Heating Surface..... | 195 |
| Maximum Possible Economy..... | 196 |
| Loss of Heat by Radiation..... | 198 |
| Capacity of a Plain Cylinder Boiler at Different Rates of Driving..... | 200 |
| Disadvantages of the Plain Cylinder Boiler..... | 200 |
| Saving Waste Heat of the Plain Cylinder Boiler..... | 202 |
| Use of a Water-tube Boiler as an Addition to the Plain Cylinder Boiler..... | 202 |
| Modern Boiler Practice in the Anthracite Coal Regions..... | 204 |

CHAPTER IX.

EFFICIENCY OF THE HEATING SURFACE.

| | |
|--|-----|
| Statement of the Problem..... | 205 |
| Radiation Considered..... | 210 |
| Calculation of the Coefficients from Results of Boiler Trials..... | 215 |
| General Formulas for Efficiency..... | 218 |
| Interpretation of the Equation..... | 219 |
| The Coefficient <i>a</i> as a Criterion of Boiler Performance..... | 220 |
| Effect of Variation of the Conditions..... | 221 |
| Effect of Heating Value of the Fuel..... | 224 |
| Loss of Efficiency due to Steam in the Gases..... | 226 |
| Practical Conclusions from the Discussion..... | 228 |
| Low Temperature of Furnace may cause High Flue Temperature..... | 232 |
| Relation of Furnace Temperature to Heating Surface Required..... | 233 |
| Blechynden's Experiments on Transmission of Heat..... | 235 |
| Durston's Experiments on Transmission of Heat..... | 239 |
| Effect of Circulation on Economy..... | 240 |
| Efficiency does Not Depend on Type of Boiler..... | 242 |

CHAPTER X.

TYPES OF STEAM-BOILERS.

| | |
|---|-----|
| Evolution of Different Forms of Boiler..... | 247 |
| Double-cylinder Boiler..... | 247 |

| | PAGE |
|--|------|
| Two-flue Boiler..... | 248 |
| Evolution of the Steam-boiler in France and England..... | 248 |
| The Elephant Boiler..... | 248 |
| The Cornish Boiler..... | 248 |
| The Lancashire Boiler..... | 248 |
| The Galloway Boiler..... | 248 |
| The Horizontal Return-flue Boiler..... | 249 |
| The Vertical Tubular Boiler..... | 251 |
| The Locomotive Boiler..... | 254 |
| The Scotch Marine Boiler..... | 255 |
| The Water-tube Boiler..... | 257 |
| Early Forms of Water-tube Boiler..... | 258 |
| More Recent Forms of Water-tube Boiler..... | 258 |
| Modern Forms of Water-tube Boiler..... | 265 |
| Water-tube Marine Boilers..... | 274 |
| Forms of Boiler used in Different Countries..... | 277 |

CHAPTER XI.

THE HORSE-POWER OF A STEAM-BOILER.—PROPORTIONS OF HEATING AND GRATE-SURFACE.—PERFORMANCE OF BOILERS.

| | |
|---|-----|
| The Horse-power of a Steam-boiler..... | 280 |
| Definitions of Boiler Horse-power..... | 281 |
| Measures for Comparing the Duty of Boilers..... | 282 |
| Proportions of Grate and Heating Surface for a Given Horse-power..... | 282 |
| Heating Surface..... | 283 |
| Measurement of Heating Surface..... | 284 |
| Horse-power, Builder's Rating..... | 285 |
| Grate-surface..... | 285 |
| Areas of Flues and Gas-passages..... | 288 |
| Air-passages through Grate-bars..... | 288 |
| Performance of Boilers..... | 289 |
| Range of Results with Anthracite Coal..... | 289 |

CHAPTER XII.

POINTS OF A GOOD BOILER.

| | |
|-------------------------------------|-----|
| Selecting a New Type of Boiler..... | 292 |
| Economy of Fuel..... | 293 |
| Danger of Explosion..... | 295 |
| Durability..... | 296 |
| Facility for Removal of Scale..... | 298 |
| Water and Steam Capacity..... | 298 |
| Steadiness of Water-level..... | 299 |
| Dryness of Steam..... | 299 |
| Water Circulation..... | 299 |

CHAPTER XIII.

BOILER TROUBLES AND BOILER-USERS' COMPLAINTS.

| | |
|---|-----|
| Causes of Complaint..... | 301 |
| Poor Draft..... | 302 |
| Insufficient Grate-surface and Poor Coal..... | 304 |
| Furnace not Adapted to Coal..... | 304 |
| Bad Setting of Boiler..... | 305 |
| Leaks of Air through Brickwork..... | 306 |
| Improper Firing..... | 307 |
| Insufficient Heating Surface..... | 311 |
| Bad Water..... | 313 |
| Corrosion, Internal..... | 313 |
| Use of Zinc as a Remedy for Corrosion..... | 316 |
| Incrustation and Scale..... | 317 |
| Boiler-compounds..... | 319 |
| Causes and Remedies for Incrustation..... | 321 |
| The Use of Boiler-compounds..... | 322 |
| Chemical Theory of Scale Remedies..... | 323 |
| External Corrosion..... | 328 |
| The Life of a Steam-boiler..... | 328 |
| Defects Discovered by Inspection..... | 329 |
| Explosions Caused by Hidden Defects..... | 329 |

CHAPTER XIV.

EVAPORATION TESTS OF STEAM-BOILERS.

| | |
|---|-----|
| Object of an Evaporation Test..... | 333 |
| Rules for Conducting Boiler Trials, Code of 1899..... | 333 |
| Forms for Report of a Trial..... | 343 |
| Appendices to Code of 1899..... | 348 |
| Computation of the Results of a Boiler Trial..... | 376 |

CHAPTER XV.

RESULTS OF STEAM-BOILER TRIALS.

| | |
|---|-----|
| Range of Economy Found in Practice..... | 380 |
| Spence's Experiments on Varying the Air-supply..... | 381 |
| Results of Tests with Small Sizes of Anthracite Coal..... | 383 |
| Tests of Stirling Boilers with Anthracite Coal..... | 386 |
| Comparative Trials of Two-flue Boilers with Pittsburg Coal..... | 392 |
| Tests of a Babcock & Wilcox Marine Boiler..... | 394 |
| Tests of a Thornycroft Boiler..... | 398 |
| Tests at the Centennial Exhibition..... | 402 |

CHAPTER XVI.

PROPERTIES OF WATER AND STEAM.—FACTORS OF EVAPORATION.—CHIMNEYS.

| | |
|--|-----|
| Properties of Water..... | 406 |
| Weight and Heat-units of Water..... | 407 |
| Properties of Steam..... | 408 |
| Steam-table..... | 411 |
| Factors of Evaporation..... | 417 |
| Chimney-draft Theory..... | 422 |
| Rate of Combustion due to Height of Chimney..... | 425 |
| Table of Sizes of Chimneys..... | 428 |

CHAPTER XVII.

MISCELLANEOUS.

| | |
|--|-----|
| Economizers..... | 430 |
| Apparatus for Indicating Furnace Conditions..... | 434 |
| The Arndt Econometer..... | 435 |
| Flue-gas Analyses and the Heat Balance..... | 436 |
| Designing Boilers for a Street-railway Plant..... | 437 |
| Loss of Fuel due to Banking Fires..... | 445 |
| Coal used in Banking Fires..... | 446 |
| Steam-boiler Economy in Electric-light Stations..... | 447 |
| Cost of Coal per Boiler Horse-power..... | 448 |
| Boiler-room Labor..... | 448 |
| Steam-boiler Practice of the Future..... | 449 |



STEAM-BOILER ECONOMY.

CHAPTER I.

PRINCIPLES AND DEFINITIONS.

A Steam-boiler is a vessel in which, by the agency of heat derived from the combustion of fuel, water is converted into steam.

The study of the operation of a steam-boiler includes the consideration of the following subjects:

1. The fuel, its kind, quality, and chemical composition.
2. The air supplied to the fuel to effect its combustion or rapid oxidation; also the moisture in the air.
3. The furnace in which the combustion, more or less complete, takes place; its construction and its fuel-burning capacity.
4. The loss of unburned fuel through the grate-bars of the furnace, or in the ashes withdrawn from it.
5. The heat generated by the combustion; its quantity; the temperature attained in and beyond the furnace; and the efficiency of the combustion, or the ratio which the quantity of heat actually generated bears to that which might be generated with perfect combustion.
6. The gaseous products of combustion, and their dilution by an excessive supply of air.
7. The transfer of heat from the fire, and from the hot gases generated by the combustion, through the shell or tubes of the boiler into the water, and the conditions which increase or diminish the rate and the effectiveness of the transfer.
8. The loss of heat due to the escape of hot gases into the flue or chimney.
9. The loss of heat due to radiation from the external surfaces of the furnace and boiler.

10. The properties of water and steam at different temperatures.

11. The capacity of the boiler, or the quantity of water it is capable of converting into steam under certain given or assumed conditions.

12. The efficiency of the boiler, or the ratio of the heat absorbed by the boiler to the heat which would be generated by the complete combustion of so much of the fuel as is actually burned.

13. The efficiency of the boiler and furnace combined, or the ratio of the heat absorbed by the boiler to the heat which would be generated by complete combustion of all the fuel used, including that lost through the grates and withdrawn in the ashes.

The consideration of each one of the several items specified above is necessary to a thorough understanding of the operation and the fuel economy of a steam-boiler, and each will be discussed at length in succeeding chapters of this book.

The general subject of steam-boiler economy, however, includes other subjects than those relating to fuel economy, such as the construction of the boiler in its relation to strength, durability, repairs, facility of cleaning, space occupied, first cost, cost of labor for its operation, etc. These will also be treated of in their proper place.

Heat is a form of energy in bodies, supposed to consist of molecular vibration. Its nature, like that of gravity and electricity, is not clearly understood, but its effects may be perceived and measured. Its intensity in any body may be measured in degrees of temperature by a thermometer or pyrometer. Its quantity may be measured in heat-units. When two bodies, one hotter or at a higher temperature than the other, are placed in contact, there is a flow of heat from the hotter into the cooler body, tending to equalize their temperature, and the quantity of heat thus transferred may be measured or estimated if the nature or composition, the weight, and the temperature of the two bodies are known. One or both the bodies may experience a *change of state* by reason of the transfer of heat. Thus if a piece of ice be plunged into a vessel containing steam, the flow of heat from the steam will condense it into water, and the flow of heat into the ice will cause the latter to melt and be changed also into water.

Temperature, or intensity of heat, is measured in degrees, by a thermometer or pyrometer. Certain fixed or standard temperatures are identified by certain phenomena of the change of state of certain bodies. The two most commonly used standard temperatures are: (1) that of melting ice, zero on the Centigrade thermometric scale or 32°

on the Fahrenheit scale, and (2) that of the boiling-point of pure water at the mean atmospheric pressure of 14.7 lbs. per square inch, viz., 100° on the Centigrade scale or 212° on the Fahrenheit scale. The Fahrenheit scale is most commonly used in England and the United States. If the range of temperature between the freezing and the boiling-points of water be divided into 180 equal parts, we obtain the scale of degrees of the Fahrenheit thermometer, which scale may be extended indefinitely downwards and upwards to measure the lowest and the highest temperatures found in the arts. For scientific measurements of great accuracy and through a wide range degrees of temperature may be measured by the air-thermometer, in which the recorded degree of temperature is proportional to the product of the pressure and volume of a given weight of air.* For all ordinary purposes the mercury thermometer is available between the range of -40° and 600° F., and mercury thermometers with compressed nitrogen in the tube above the mercury may be used for temperatures as high as 900° or 1000° F. For higher temperatures, up to 3000° F., the Uehling and Steinbart air-pyrometer, and the Chatelier electric pyrometer are available. For obtaining the temperature of chimney-gases, from 300° to 1200° , metallic pyrometers may be used, but their indications are apt to be inaccurate.

The temperatures commonly observed in steam-boiler practice are, on the Fahrenheit scale:

1. The temperature of the feed-water, from 32° to 300° and upwards.
2. The temperature of the steam, from 212° to 400° (corresponding to saturated steam of 250 lbs. per sq. in. absolute pressure) and upwards (500° or over for highly superheated steam).
3. The temperature in the furnace, from 1000° to 3000° or upwards.
4. The temperature of the escaping flue-gases, from 300° to 1200° and upwards.
5. Temperatures of the gases of combustion, taken at points in the gas-passages through the boiler intermediate between the furnace and the flue.

A Heat-unit, or British Thermal Unit (B.T.U.), is the quantity of heat required to raise the temperature of one pound of pure water

* Consult Rankine, Steam-engine, p. 226; Kent's Mech. Engrs. Pocket-book, p. 454; Trans. A. S. M. E., vol. vi. p. 282.

one degree Fahrenheit, at and near its temperature of greatest density, 39.1° F. (Rankine).

The quantity of heat required to raise the temperature of one pound of water 1° F. varies very slightly with the temperature, being nearly constant below 100° F. and increasing at higher temperatures, so that to raise its temperature from 32° to 100° requires 68.08 instead of 68 B.T.U., and from 32° to 212°, 180.9 instead of 180 B.T.U.

The Unit of Evaporation (U.E.) is the quantity of heat required to convert one pound of water at 212° into steam of the same temperature. It is equivalent to 965.7 B.T.U.

Latent Heat is the quantity of heat which apparently disappears (or becomes latent or hidden, and therefore not measurable by a thermometer) when a body changes its state from solid to liquid or from liquid to gaseous, while the temperature remains constant. Thus when a pound of ice at 32° is converted into water at the same temperature, 142 B.T.U. becomes latent, and when a pound of water at 212° is converted into steam at 212°, 965.7 B.T.U. (or one U.E.) becomes latent.

When a body changes its state from the gaseous to the liquid form, or from the liquid to the solid form, the heat which was latent is given off and becomes sensible heat. Thus a pound of steam at 212° in condensing to water at 212° transfers 965.7 B.T.U. to surrounding bodies, raising their temperature, and a pound of water at 32° freezing into ice at the same temperature will give off 142 B.T.U. to the surrounding atmosphere.

Specific Heat is a figure representing the quantity of heat, expressed in thermal units, required to raise the temperature of one pound of any given substance one degree; or it is the ratio of the quantity of heat required to raise the temperature of a given weight of the substance one degree to the quantity required to raise the temperature of the same weight of water one degree at its temperature of maximum density. The specific heat of water at 39.1° F. being taken at unity, that of all other known substances, except hydrogen, is less than unity.

One of the methods of determining the specific heat of a body is the method by mixture, described as follows:

The body whose specific heat is to be determined is raised to a known temperature, and is then immersed in a mass of liquid of which the weight, specific heat, and temperature are known. When

both the body and the liquid have attained the same temperature, this is carefully ascertained.

Now the quantity of heat lost by the body is the same as the quantity of heat absorbed by the liquid.

Let c , w , and t be the specific heat, weight, and temperature of the hot body, and c' , w' , and t' of the liquid. Let T be the temperature the mixture assumes.

Then, by the definition of specific heat, $c \times w \times (t - T) =$ heat-units lost by the hot body, and $c' \times w' \times (T - t') =$ heat-units gained by the cold liquid. If there is no heat lost by radiation or conduction, these must be equal, and

$$cw(t - T) = c'w'(T - t') \quad \text{or} \quad c = \frac{c'w'(T - t')}{w(t - T)}.$$

The specific heats of several different substances at ordinary atmospheric temperatures are given below:

SOLIDS.

| | | | |
|--------------------|--------|-------------------------|--------------|
| Copper..... | 0.0951 | Aluminum | 0.2185 |
| Glass..... | 0.1937 | Charcoal..... | 0.2410 |
| Iron, cast..... | 0.1298 | Coal..... | 0.20 to 0.24 |
| Iron, wrought..... | 0.1138 | Coke..... | 0.203 |
| Steel, soft..... | 0.1165 | Brickwork and masonry.. | about 0.20 |
| Platinum..... | 0.0324 | Wood..... | 0.46 to 0.65 |

LIQUIDS.

| | | | |
|------------|--------|--------------|--------|
| Water..... | 1.0000 | Mercury..... | 0.0333 |
|------------|--------|--------------|--------|

GASES.

| | At Constant Pressure. | At Constant Volume. |
|--|-----------------------|---------------------|
| Steam, superheated..... | 0.4805 | 0.346 |
| Air..... | 0.2375 | 0.1686 |
| Oxygen..... | 0.2175 | 0.1551 |
| Hydrogen..... | 3.4090 | 2.4122 |
| Nitrogen..... | 0.2438 | 0.1727 |
| Carbon monoxide, CO | 0.2479 | 0.1758 |
| Carbon dioxide, CO ₂ | 0.217 | 0.1535 |
| Marsh-gas (methane), CH ₄ | 0.5929 | 0.4683 |
| Olefiant gas (ethylene), C ₂ H ₄ | 0.404 | 0.173 |
| Blast-furnace gas..... | C.228 | |
| Gases in chimneys of steam-boilers (approximate) | 0.240 | |

The specific heat of a gaseous mixture, such as that of chimney-gas, is found by multiplying the percentage of each of the constituent gases by the specific heat of that gas and dividing the sum of the prod-

acts by 100. Thus for a gas whose composition is CO_2 , 12; CO , 0.5; O , 9.5; N , 78, we have

| | | | | | |
|-----------------------|-------|---|--------|---|--------|
| CO ₂ | 12 | × | 0.217 | = | 2.604 |
| CO..... | 0.5 | × | 0.248 | = | 0.124 |
| O | 9.5 | × | 0.2375 | = | 2.256 |
| N | 78 | × | 0.2438 | = | 19.016 |
| | 100.0 | | | | 24.000 |

Whence the specific heat is

$$24.0 \div 100 = 0.240.$$

The specific heats of all substances in the solid or liquid state increase slowly as the temperature rises. Experiments by Mallard and Le Chatelier indicate a continuous increase in the specific heat of CO_2 , steam, and other gases with rise of temperature. The variation is inappreciable at 212°F ., but increases rapidly at high temperatures. In the absence of data of specific heats of gases at high temperatures, the figures given in the above tables are generally used in calculations relating to gases of combustion, although their use may lead to errors of unknown magnitude in the results.

The following figures, showing increase of specific heat of metals with rise of temperature, are sometimes used in pyrometric calculations:

| | |
|---|--------|
| Platinum, 22° to 440°F ., 0.0332, increasing 0.000305 for each 100°F . above 440° . | |
| Copper, 32° to 212° | 0.094 |
| “ 32° to 572° | 0.1013 |
| Wrought iron,* 32° to 200° | 0.1129 |
| “ 32° to 600° | 0.1327 |
| “ 32° to 2000° | 0.2619 |

The Quantity of Heat in a body, in British thermal units, measured above a certain temperature taken as standard, usually 32°F ., is the product of its weight, its average specific heat between the limits of temperature considered, and the difference between its temperature and the standard temperature. Thus the quantity of heat above 32° in a piece of wrought iron weighing 10 lbs., at a temperature of 212° , is $10 \times .1138 \times (212 - 32) = 204.84 \text{ B.T.U}$.

This statement is true, however, only when the body does not change its state between the standard temperature and the higher temperature. When the body changes its state, its latent heat must be considered. Thus the heat above 32° in a pound of steam is the sum of

| | |
|---|--------------|
| Heat required to raise its temperature from 32° to 212° | 180.9 B T.U. |
| Latent heat of evaporation at 212° | 965.7 “ |
| Total..... | 1146.6 “ |

* J. C. Hoadley, Trans. A. S. M. E., vi. 713.

The quantity of heat in a pound of saturated steam at 320° F. (75.3 lbs. gauge pressure per sq. in.) is

| | |
|--|-----------------|
| Heat (above 32°) in water at 320°..... | 291.2 B.T.U. |
| Latent heat of evaporation at 320° | 888.4 “ |
| Total.. | <u>1179.6</u> “ |

When the steam is superheated, the quantity of heat required for superheating must be added. Thus if the steam of 75.3 lbs. gauge pressure, whose temperature when saturated is 320°, be superheated, while its pressure remains constant, to 420°, the increase of 100° of temperature will require, since the specific heat of superheated steam at constant pressure is 0.48, an addition of 48 B.T.U., making the total heat 1179.6 + 48 = 1227.6 B.T.U. The properties of steam will be discussed further in another chapter.

Heat of Combustion.—Every combustible chemical element, such as carbon, hydrogen, and sulphur, and every gaseous fuel of definite chemical composition, containing two or more elements, such as carbon monoxide (CO) and methane (marsh-gas, CH₄), when completely burned in oxygen or in air generates a definite quantity of heat per pound of the combustible, which quantity may be ascertained with a close approximation to accuracy by means of an instrument known as a fuel calorimeter. The exact determination of the heat of combustion, or calorific value, of any combustible requires a very delicate apparatus, a high degree of skill on the part of the operator, and an allowance for certain unavoidable errors, such as loss by radiation, so that the calorific values of different combustibles as reported by different authorities show a slight variation. Thus the heating value of carbon is 14,544 B.T.U. according to Favre and Silbermann, and 14,647 B.T.U. according to Berthelot. That of hydrogen is 62,032 B.T.U. according to Favre and Silbermann, and 61,816 B.T.U. according to Thomsen. The round figures of 14,600 B.T.U. for carbon (burned to carbon dioxide) and 62,000 B.T.U. for hydrogen (burned to steam and the steam condensed to liquid water) are generally used in calculations relating to steam-boiler practice.

The heating value of any fuel, such as coal, consisting of a mixture of combustible and non-combustible substances may be directly determined by means of a calorimeter, or it may be calculated from its ultimate chemical analysis by Dulong's formula, which is:

$$\text{Heating value} = \frac{1}{100} \times \left[14,600 \text{ C} + 62,000 \left(\text{H} - \frac{\text{O}}{8} \right) + 4000 \text{ S} \right],$$

in which C, H, O, and S are the percentages of carbon, hydrogen, oxygen, and sulphur in the coal, as determined by analysis.

Combustion of Fuel.—Combustion may be perfect or imperfect, depending upon the supply of air in the furnace and upon other conditions which will be discussed later. When the combustion is perfect the whole of the carbon in the fuel is burned to carbon dioxide, CO_2 , each pound generating 14,600 B.T.U., and the whole of the hydrogen is burned to steam, or vapor of water, H_2O , each pound generating 62,000 B.T.U. Part of the heat of the combustion of hydrogen is absorbed in the latent heat of evaporation of the 9 lbs. of steam formed by the combustion of 1 lb. of hydrogen, and another part in superheating, to the temperature of the furnace, this steam, and also the steam that may be derived from moisture in the coal or in the air supplied to the furnace.

When the combustion is imperfect part of the carbon may be burned only to carbon monoxide, CO , generating only 4450 B.T.U. per pound; or part of the carbon which has been burned on the grate to CO_2 may be “unburned,” being converted into CO on passing through a bed of red-hot coke, absorbing carbon therefrom by the chemical reaction $\text{CO}_2 + \text{C} = 2\text{CO}$, a cooling process, absorbing 10,150 B.T.U. per pound of the C originally burned to CO_2 . Also, in imperfect combustion some of the hydrogen, together with the carbon with which it is combined in the coal, forming the “volatile matter,” may be only distilled from the coal and not burned, or the hydrogen only in this volatile matter may be burned, leaving the carbon, in the form of soot or smoke, to be carried off in the gases passing out of the furnace. All of the products of imperfect combustion, the carbon monoxide, the hydrocarbon gases distilled from the coal, and the soot or smoke, may afterwards be burned if they are carried into a very hot chamber, where they are brought in contact with a sufficient supply of highly heated air.

How Smoke may be Burned.—This last statement is contrary to that made by Charles Wye Williams in his treatise “On the Combustion of Coal and the Prevention of Smoke,” first printed about sixty years ago, and copied extensively by later writers, viz., that “When smoke is once produced in a furnace or flue, it is as impossible to burn it or convert it to heating purposes as it would be to convert the smoke issuing from the flame of a candle to the purposes of heat or light.” The error of the statement made by Mr. Williams can be easily shown by a simple experiment which has been made by the

author. A short piece of candle was placed inside of a tall, narrow tin cylinder. The deficient supply of air the candle thus received caused it to give off a column of black smoke. This was caused to pass into the central-draft tube of a "Rochester" kerosene lamp, and as it passed up into the flame of the lamp it was completely burned, not a trace of smoke being visible in the lamp-chimney. The experiment was also made with a still larger column of smoke, produced by burning paper under the lamp, with the same result.

Flame is a mass of intensely heated combustible gas. It is not necessarily gas in a state of combustion, for combustion cannot take place without access of air, and flame may exist, as in passing through a furnace or flue, where there is no supply of air to burn the gas. If the flame in passing through a tube becomes cooled below a bright red heat, the gas will not burn when it escapes and comes in contact with cool air, but will be chilled and pass off as unburned gas and smoke.

The flame of pure hydrogen gas is almost invisible, but visibility and color may be given to it by the presence of other substances; thus carbon will make it white, copper green, cyanogen purple, and sodium yellow.

The white color of the flame of hydrocarbon gas, such as that from a candle or that of a kerosene lamp, is due to intensely heated particles of carbon. If the flame is caused to impinge on a cold surface, some of these particles will be deposited as soot.

Visible flame is evidence of imperfect combustion or non-combustion. The product of the perfect combustion of carbon is invisible carbon dioxide gas, and that of hydrogen is invisible vapor of water.

Take a lighted central-draft kerosene lamp and adjust the wick to such a point that the lamp gives a rather short and clear white light without a trace of smoke. Now, without altering the adjustment of the wick, gradually obstruct the opening at the bottom of the central-draft-tube and observe the result. The flame grows longer and its whiteness changes to yellow and then to red. It begins to smoke, and finally when the supply of air is nearly shut off the flame has risen to nearly the top of the chimney and a dense column of black smoke and soot is given off. We learn from this experiment that with the same consumption of fuel, i.e., the oil supplied by the wick, the flame may be short and intensely hot, or very long, of a low temperature, smoky and sooty. While the flame is lengthening and before it becomes smoky the combustion may be complete, but it is not effected in as short a space as it was with the original supply of air. For a given supply of fuel

a short flame means rapid and complete combustion, a longer flame delayed combustion, and a very long flame imperfect combustion. If midway in the flame of medium length a cool surface be interposed, the temperature of the flame will be lowered, the combustion will be rendered imperfect, and smoke and soot will be produced.

The principles learned from these simple experiments with the flame of a lamp are of great importance in connection with the study of the action of steam-boiler furnaces.

A Transfer of Heat from the burning fuel and from the hot gases produced by its combustion into the water contained in a steam-boiler takes place through the metal plates and tubes of the boiler in two ways: (1) by radiation directly from the fire and from the hot particles of carbon in the flame, and (2) by contact of the hot gases with the metal of the boiler. The laws of these two methods of transfer are as yet imperfectly understood, and there is a great lack of accurate scientific data concerning them. The experimental determination of these data is a matter of extreme difficulty, on account of the number of variable conditions attending the experiments. Such conditions are: the extent of surface exposed to direct radiation; the temperature of the radiating surfaces, the resistance to radiation of metal plates in different conditions, more or less coated with scale and soot; the manner in which the heated gases impinge upon the shell and tubes; the triple resistance to transfer of heat from the gases to the water, viz., the resistances of the external and internal surfaces of the metal, varying with their condition, and the resistance of the metal between these surfaces, varying with the nature of the metal and its thickness; the influence which the temperature of the gases on one side of the plate and tubes, steadily decreasing as they pass from the furnace to the flue, and the temperature of the water on the other, sensibly constant, have upon the rate of transfer of heat through the metal and its exterior and interior surfaces. Notwithstanding, however, the lack of accurate knowledge concerning the influence of these several variables on the transfer of heat in steam-boilers, enough is known to enable us to deduce some broad general laws, and to express some of them in empirical formulæ, so that boilers may intelligently be designed to fill given requirements, and so that the probable performance of any boiler and furnace may be predicted from a study of its design and dimensions, when the character of the fuel is known, within limits of error sufficiently narrow for practical purposes.

The Capacity of a Boiler is its capacity for producing steam. It

may be expressed in the number of heat-units absorbed by the boiler in a given time, such as one second, or in the number of pounds of water converted into steam in an hour.

“Equivalent” Evaporation.—Since the latter number will depend upon the temperature of the feed-water and upon the pressure or temperature of the steam, it is customary to express the capacity in terms of what is called “equivalent evaporation,” that is, reducing the number of pounds of steam actually generated at a given or observed pressure from feed-water of an observed temperature, into the equivalent evaporation per hour from feed-water of 212° into steam at the same temperature, or, as it is commonly expressed, “equivalent evaporation per hour from and at 212° .”

The evaporation of a pound of water from and at 212° being the “unit of evaporation” (U.E.), equal to 965.7 B.T.U., the capacity of a boiler may be stated as so many U.E. per hour.

Boiler Horse-power.—Another convenient method of expressing the capacity of a boiler is in terms of “Boiler Horse-power,” a boiler horse-power being equal, according to a commonly accepted convention, to $34\frac{1}{2}$ U.E. per hour, or $34\frac{1}{2}$ lbs. of water evaporated from and at 212° per hour. This latter is the usual method of expressing the capacity of stationary boilers in the United States. It is not used for marine or locomotive boilers.

A boiler rated at 100 H.P. would therefore be rated also at a capacity of 3450 lbs. of water from and at 212° per hour, or at 3,331,665 B.T.U. per hour, or 925.5 B.T.U. per second. The B.T.U. rating is not used in practice, as it is not so convenient as the other methods of rating.

It is to be noted that the “rating” of a boiler as 100 H.P. may be very different from the actual capacity it may show under a given set of conditions. The “rating” is supposed to be its average capacity under easy conditions of driving, with fairly good fuel, and with ordinary draft. Two boilers exactly alike in all respects may both be rated at 100 H.P., and one of them with excellent fuel and forced draft may be actually developing 200 H.P., while the other, with poor fuel or insufficient draft or both, may not be capable of developing over 75 H.P.

The Efficiency of a Boiler may mean: 1. The ratio of the heat absorbed by it to the heat actually generated in the furnace; 2. The ratio of the heat absorbed by it to the heating value of the combustible actually burned (whether thoroughly or not); 3. The ratio of the

heat absorbed by it to the heating value of the fuel supplied to the furnace, whether all the fuel is burned or not (some of the fuel may fall through the grates or be withdrawn with the ashes, and not be burned). The first of these efficiencies is not used in practice, for the reason that there is no convenient way of estimating the amount of heat actually generated in the furnace, or of determining what portion of the fuel is imperfectly burned. The second and third are commonly used and are thus defined:

$$\text{Efficiency of the boiler} = \frac{\text{Heat absorbed per lb. combustible}}{\text{Heating value of 1 lb. combustible}}$$

$$\text{Efficiency of the boiler and grate} = \frac{\text{Heat absorbed per lb. coal}}{\text{Heating value of 1 lb. coal}}$$

The meaning of the word "combustible" in the above definitions is that portion of the total fuel supplied to the furnace which remains after deducting its moisture (determined by a test of a sample) and the total amount of ash and refuse (including unburned coal) withdrawn from the furnace, through the grates or otherwise. In other words it is the sum of the fixed carbon and the volatile combustible matter, or the "coal dry and free from ash."

The Operation of a Steam-boiler.—The several events that take place in the operation of an ordinary steam-boiler may be briefly described as follows: Consider that the furnace is already heated, a hot fire of partially burned coal or coke lying on the grate, and that the boiler is delivering steam as usual. A few shovelfuls of fresh coal are evenly spread over the bed of hot coal, to replenish the fire. The first thing that then takes place is the evaporation of the moisture contained in the fresh coal. This absorbs heat from the fire, cooling it for a short time. If the fresh coal is of small size, it partly fills the interstices between the pieces of hot coal, and thereby checks the draft and diminishes the supply of air which enters through the grate. The formation of the steam by the evaporation of the moisture in the fuel, together with the reduction of the air-supply, may cause two chemical actions to take place which are in the nature of "decomposition" or the reverse of combustion or rapid oxidation, both of which are detrimental to the most economical operation of the boiler. The first is the decomposition of the carbon dioxide, formed by the union of the oxygen of the air with the carbon of the hot coal lying next to the grate-bars, into carbon monoxide, by the reaction $\text{CO}_2 + \text{C} = 2\text{CO}$, which takes place when carbon dioxide is passed through a

bed of very hot coal or coke, the supply of air being deficient. The second is the decomposition of a portion of the steam produced by the evaporation of the moisture in the coal, by the reaction $H_2O + C = 2H + CO$, which takes place when steam is brought in contact with very hot carbon. Both of these reactions or decompositions are cooling processes, absorbing heat from the fire, and they therefore diminish the rate of transfer of heat through the heating surface of the boiler. Moreover, they both rob the bed of fuel of some of its carbon, converting it into combustible gases which may escape unburned, thus causing a loss of heat. Fortunately the length of time during which these reactions, unfavorable to economy, take place is not long when the firing is done carefully, and the fresh coal is fired only in small quantities at a time.

After the moisture is driven off from the coal the volatile matter begins to be distilled, and this continues until the fresh coal has attained a red heat. When the amount of this volatile matter is small, when the air-supply is sufficient, and when the furnace is at a high temperature, it may all be completely burned before it passes out of the furnace; but if it is distilled in large volume and is not brought into intimate mixture with air at a temperature high enough to maintain ignition, more or less of it will escape unburned.

After the volatile matter has been driven off, the combustion of the remainder of the coal or coke is completed. If the relation of the thickness of the bed of coal on the grate to the force of the draft is such that only so much air passes through the grate as will cause the complete combustion of the carbon to CO_2 , the temperature of the furnace will be very high, a most favorable condition for economy of the boiler. If the force of the draft be excessive, in relation to the resistance of the grate and the fuel upon it to the passage of air, or if the bed of coal be too thin, an excessive supply of air will pass into the furnace, lowering its temperature and making conditions unfavorable to economy. If, on the other hand, the thickness of the bed of coal is too great in its relation to the force of the draft, or the draft is insufficient, the air supplied to the furnace will not be enough to secure complete combustion, part of the carbon will be burned only to CO , and the furnace temperature will be low. In this case there is thus a twofold loss of economy: first, that due to direct loss of heat-units by imperfect combustion; and second, that due to low furnace temperature, which lessens the rate of transfer of heat into the boiler.

While the coal is being burned as above described it generates a

quantity of heat, more or less according to the degree of completeness of combustion, at a rate varying from one instant to another as the conditions vary, the coal giving off moisture at one period, distilling its volatile matter at another, and having its carbon burned more or less perfectly at another. The temperature of the furnace also varies as these conditions vary, and with it the rate of transfer of heat into the boiler both by radiation and by conduction.

A portion of the heat generated in the furnace being radiated directly from it into the boiler, and a very small portion escaping by radiation through the walls of the furnace (if it is not enclosed in the boiler itself, as in internally fired boilers), the remainder of the heat passes out of the furnace in the heated gases of combustion. These give up to the boiler a portion of their heat as they pass along the heating surfaces, and carry what remains into the flue leading to the economizer or to the chimney, as the case may be. How much of this heat shall be absorbed by the boiler and how much shall pass into the chimney depends upon a number of variable conditions which will be discussed later.

Efficiency of the Heating Surface.—The two principal sources of loss of heat in the ordinary operation of a steam-boiler are: 1. The loss due to imperfect combustion; 2. The loss of heat in the chimney-gases.

If H_1 represents the heat-units in 1 lb. of the gases of combustion in the furnace, and H_2 the heat-units in the same quantity of the same gases as they leave the boiler, the efficiency of the heating surface is represented by the equation

$$E = \frac{H_1 - H_2}{H_1} \dots \dots \dots (1)$$

If T_1 represents the temperature of the gases in the furnace, and T_2 their temperature as they leave the boiler, the efficiency is also represented by the equation

$$E = \frac{T_1 - T_2}{T_1} \dots \dots \dots (2)$$

on the assumption that the specific heat of the gases is the same at each of the two temperatures.

From equation (2) we learn that the efficiency of the heating surface may be increased either by increasing T_1 or by decreasing T_2 or by both. Therefore high efficiency depends both on high furnace temperature and on low chimney temperature. How to increase the furnace temperature, and how, with increased furnace temperature, to

decrease the chimney temperature, are the principal things to be learned in regard to the fuel economy of steam-boilers.

The efficiency of the heating surface corresponding to different temperatures T_1 and T_2 is shown in the following table:

| | $T_1 =$ | 2500° | 2000° | 1500° | 1000° |
|-------------------------|---------|-----------------------|-------|-------|-------|
| | | Efficiency, per cent. | | | |
| $T_2 = 300^\circ \dots$ | | 88 | 85 | 80 | 70 |
| 400°..... | | 84 | 80 | 73.3 | 60 |
| 500°..... | | 80 | 75 | 66.7 | 50 |
| 600°..... | | 76 | 70 | 60 | 40 |
| 700°..... | | 72 | 65 | 53.3 | 30 |
| 800°..... | | 68 | 60 | 46.7 | 20 |
| 900°..... | | 64 | 55 | 40 | 10 |
| 1000°..... | | 60 | 50 | 33.3 | 0 |

The highest figure of efficiency in the above table, 88%, it is scarcely possible to realize in practice except under unusual conditions, such as the supplying of the furnace with hot air heated by the utilization of some of the heat of the escaping chimney-gases. The lowest figure, 0%, represents an impossible condition, that of no transfer of heat from the gases into the boiler.

The principles briefly outlined in this chapter form the basis of the theory of the economy of fuel in steam-boilers. They will all be considered in greater detail, with reference to experimental data, in succeeding chapters.

CHAPTER II.

FUEL AND COMBUSTION.

Chemistry of Fuel and of Combustion.—The four principal chemical elements found in fuel and in the air used for its combustion are carbon, hydrogen, oxygen, and nitrogen. The chemical symbols and the atomic weights of these four elements are respectively C, 12; H, 1; O, 16; N, 14. The atomic weights, or combining numbers, are the relative proportions by weight in which the elements always combine with each other to form definite chemical compounds. Some of these compounds are the following:

| | Parts by Weight. |
|------------------------------|----------------------|
| Water, H_2O | $2H + 16O = 18H_2O$ |
| Carbon monoxide, CO | $12C + 16O = 28CO$ |
| Carbon dioxide, CO_2 | $12C + 32O = 44CO_2$ |
| Methane, CH_4 | $12C + 4H = 16CH_4$ |

The names of the last three compounds are those used in modern works on chemistry. Their older names are: CO , carbonic oxide; CO_2 , carbonic acid; CH_4 , marsh-gas, or light carburetted hydrogen.

Air is not a chemical compound, but a mixture of oxygen and nitrogen.

Water-gas (pure), $2H + CO$, is a mixture of two parts hydrogen and 28 parts carbon monoxide.

Carbon is found in the pure and solid state in the diamond, in charcoal, and in graphite. Combined with hydrogen it is found in various oils, tars, and gases. Combined with hydrogen and oxygen it is found in the whole range of vegetable products. It is the principal constituent of coal and of most other fuels, whether solid, liquid, or gaseous.

Hydrogen is a very light combustible gas, of only about $\frac{1}{14}$ of the density of air. It may be produced in its pure gaseous state by the electrical or chemical decomposition of water. It is also formed, mixed with carbon monoxide, when steam is passed through a body of white-hot carbon, the chemical reaction being thus expressed:

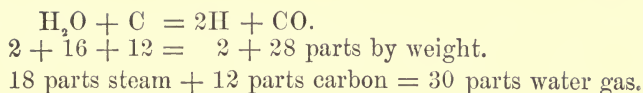

Hydrogen is a constituent of most fuels, solid, liquid, and gaseous, combined either with carbon or with both carbon and oxygen in various proportions.

Oxygen is an invisible gas, 16 times as heavy as hydrogen. It is found in the gaseous state, mixed with nitrogen, in air. Combined with $\frac{1}{8}$ of its weight of hydrogen it forms water. It is the universal supporter of combustion, and is the active agent of corrosion or rusting, forming oxides of the metals. It is found combined with hydrogen and carbon in wood and other vegetable products, forming about 40 per cent of the weight of dry wood; and it is found in coal in proportions varying from 1 per cent or less in anthracite to over 25 per cent in lignites.

Nitrogen is also an invisible gas, 14 times as heavy as hydrogen. It has so little chemical affinity for other substances that it cannot easily be combined with them by ordinary chemical methods. The fixation of the nitrogen of the air, or causing it to combine with alkalis to form fertilizers, is one of the great unsolved problems of the chemist. It is the diluent of oxygen in air, restraining its activity, and causing combustion and corrosion to be less rapid than if they were effected in pure oxygen. It is one of the chief causes of loss of heat in the operation of steam-boilers, since it enters the furnace at the temperature of the atmosphere and escapes in the chimney-gases at a high temperature. It is found in all coals, usually to the extent of from 0.5 to 2 per cent of their weight. When coal is distilled this nitrogen appears in the vapors, combined with hydrogen, as ammonia, NH_3 , and when the coal is burned the NH_3 is decomposed and part of the N is oxidized to nitric acid, HNO_3 .

Sulphur is found in most coals, in amounts ranging from 0.5 per cent to occasionally 5 per cent or more in some poor coals. It is contained in them usually as iron pyrites (sulphide of iron), but sometimes as sulphate of lime. It is always an objectionable constituent of coal, since it causes the formation of clinker by the fusion of the ash. It has a slight value as fuel when in the form of sulphide of iron, 1 lb. of sulphur in that form having a heating value about equal to that of $\frac{1}{4}$ lb. of carbon. In the form of sulphate of lime it has no heating value.

Properties of Air.—Pure dry air is composed of a mixture of

20.91 parts O and 79.09 parts N by volume,
 or 23.15 parts O and 76.85 parts N by weight.

The figure 20.91 is the average result of several determinations of oxygen in air, given in Hempel's Gas Analysis. The parts by weight are calculated from this figure, using 15.963 and 14.012 as the relative density, respectively, of oxygen and nitrogen, referred to hydrogen as 1.

The proportions usually given in text-books are: by volume, 21 O, 79 N; and by weight, 23 O, 77 N.

The proportion of nitrogen to oxygen by weight is $76.85 \div 23.15 = 3.320$; by volume, $79.09 \div 20.91 = 3.782$.

The proportion of air to oxygen by weight is $100 \div 23.15 = 4.320$; by volume, $100 \div 20.91 = 4.782$.

Ordinary atmospheric air, outdoors, contains about 4 parts in 10,000 of carbon dioxide, and a quantity of vapor of water depending upon the temperature and the relative humidity of the atmosphere. The relative humidity is the percentage of moisture contained in the air as compared with the amount it is capable of holding at the same temperature; it is determined by the use of the dry- and wet-bulb thermometer. The degree of saturation for different readings of the thermometer is given in the following table, condensed from one published by the U. S. Weather Bureau in 1897:

RELATIVE HUMIDITY, PER CENT.

| Dry Thermometer, Deg. F. | Difference between the Dry and Wet Thermometers, Deg. F. | | | | | | | | | | | | | | | | | | | | | | | | | | | | | |
|-----------------------------|--|----|----|----|----|----|----|----|----|----|----|----|----|----|----|----|----|----|----|----|----|----|----|----|----|----|----|--|--|--|
| | 1 | 2 | 3 | 4 | 5 | 6 | 7 | 8 | 9 | 10 | 11 | 12 | 13 | 14 | 15 | 16 | 17 | 18 | 19 | 20 | 21 | 22 | 23 | 24 | 26 | 28 | 30 | | | |
| | Relative Humidity, Saturation being 100. | | | | | | | | | | | | | | | | | | | | | | | | | | | | | |
| 32 | 90 | 79 | 69 | 59 | 50 | 40 | 31 | 21 | 12 | 3 | | | | | | | | | | | | | | | | | | | | |
| 40 | 92 | 84 | 76 | 68 | 60 | 53 | 45 | 38 | 30 | 22 | 16 | 8 | 1 | | | | | | | | | | | | | | | | | |
| 50 | 93 | 87 | 80 | 74 | 67 | 61 | 55 | 50 | 44 | 38 | 33 | 27 | 22 | 16 | 11 | 6 | 1 | | | | | | | | | | | | | |
| 60 | 94 | 89 | 84 | 78 | 73 | 68 | 63 | 58 | 53 | 48 | 44 | 39 | 34 | 30 | 26 | 22 | 18 | 14 | 10 | 6 | 2 | | | | | | | | | |
| 70 | 95 | 90 | 86 | 81 | 77 | 72 | 68 | 64 | 60 | 55 | 52 | 48 | 44 | 40 | 36 | 33 | 29 | 26 | 23 | 19 | 16 | 13 | 10 | 7 | 1 | | | | | |
| 80 | 96 | 92 | 87 | 83 | 79 | 75 | 72 | 68 | 64 | 61 | 57 | 54 | 51 | 47 | 44 | 41 | 38 | 35 | 32 | 29 | 26 | 23 | 20 | 18 | 13 | 8 | 3 | | | |
| 90 | 96 | 92 | 88 | 85 | 81 | 78 | 75 | 71 | 68 | 65 | 62 | 59 | 56 | 53 | 50 | 47 | 44 | 41 | 39 | 36 | 34 | 32 | 29 | 26 | 22 | 17 | 13 | | | |
| 100 | 97 | 93 | 90 | 86 | 83 | 80 | 77 | 74 | 71 | 68 | 65 | 62 | 59 | 57 | 54 | 51 | 49 | 47 | 44 | 42 | 39 | 37 | 35 | 33 | 29 | 25 | 21 | | | |
| 110 | 97 | 94 | 90 | 87 | 84 | 81 | 78 | 76 | 73 | 70 | 67 | 65 | 62 | 60 | 57 | 55 | 53 | 50 | 48 | 46 | 44 | 42 | 40 | 38 | 34 | 30 | 27 | | | |
| 120 | 97 | 94 | 91 | 88 | 85 | 83 | 80 | 77 | 75 | 72 | 70 | 67 | 65 | 62 | 60 | 58 | 56 | 54 | 51 | 49 | 47 | 45 | 44 | 42 | 38 | 35 | 31 | | | |
| 140 | 97 | 95 | 92 | 89 | 87 | 84 | 82 | 79 | 77 | 75 | 73 | 71 | 68 | 66 | 64 | 62 | 60 | 58 | 56 | 55 | 53 | 51 | 49 | 48 | 44 | 41 | 38 | | | |

WEIGHTS OF AIR, VAPOR OF WATER, AND SATURATED MIXTURES OF AIR AND VAPOR AT DIFFERENT TEMPERATURES, UNDER THE ORDINARY ATMOSPHERIC PRESSURE OF 29.921 INCHES OF MERCURY.

| Temperature, Fahrenheit. | Weight of a Cubic Ft. of Dry Air at Different Temperatures, lbs. | Elastic Force of Vapor, Inches of Mercury. | Mixtures of Air Saturated with Vapor. | | | | |
|--------------------------|--|--|--|---|------------------------------|----------------------------------|--|
| | | | Elastic Force of the Air in Mixture of Air and Vapor. Inches of Mercury. | Weight of Cubic Foot of the Mixture of Air and Vapor. | | | Weight of Vapor mixed with 1 lb. of Air, pounds. |
| | | | | Weight of the Air, lbs. | Weight of the Vapor, pounds. | Total Weight of Mixture, pounds. | |
| 0° | .0864 | .044 | 29.877 | .0863 | .000079 | .086379 | .00092 |
| 12 | .0842 | .074 | 29.849 | .0840 | .000130 | .084130 | .00155 |
| 22 | .0824 | .118 | 29.803 | .0821 | .000202 | .082302 | .00245 |
| 32 | .0807 | .181 | 29.740 | .0802 | .000304 | .080504 | .00379 |
| 42 | .0791 | .267 | 29.654 | .0784 | .000440 | .078840 | .00561 |
| 52 | .0776 | .388 | 29.533 | .0766 | .000627 | .077227 | .00819 |
| 62 | .0761 | .556 | 29.365 | .0747 | .000881 | .075581 | .01179 |
| 72 | .0747 | .785 | 29.136 | .0727 | .001221 | .073921 | .01680 |
| 82 | .0733 | 1.092 | 28.829 | .0706 | .001667 | .072267 | .02361 |
| 92 | .0720 | 1.501 | 28.420 | .0684 | .002250 | .070717 | .03289 |
| 102 | .0707 | 2.036 | 27.885 | .0659 | .002997 | .068897 | .04547 |
| 112 | .0694 | 2.731 | 27.190 | .0631 | .003946 | .067046 | .06253 |
| 122 | .0682 | 3.621 | 26.300 | .0599 | .005142 | .065042 | .08584 |
| 132 | .0671 | 4.752 | 25.169 | .0564 | .006639 | .063039 | .11771 |
| 142 | .0660 | 6.165 | 23.756 | .0524 | .008473 | .060873 | .16170 |
| 152 | .0649 | 7.930 | 21.991 | .0477 | .010716 | .058416 | .22465 |
| 162 | .0638 | 10.099 | 19.822 | .0423 | .013415 | .055715 | .31713 |
| 172 | .0628 | 12.758 | 17.163 | .0360 | .016682 | .052682 | .46338 |
| 182 | .0618 | 15.960 | 13.961 | .0288 | .020536 | .049336 | .71300 |
| 192 | .0609 | 19.828 | 10.093 | .0205 | .025142 | .045642 | 1.22643 |
| 202 | .0600 | 24.450 | 5.471 | .0109 | .030545 | .041445 | 2.80230 |
| 212 | .0591 | 29.921 | 0.000 | .0000 | .036820 | .036820 | Infinite. |

The weight in lbs. of the vapor mixed with 100 lbs. of pure air at any given temperature and pressure is given by the formula

$$\frac{62.3 \times E}{29.92 - E} \times \frac{29.92}{p}$$

where E = elastic force of the vapor at the given temperature, in inches of mercury; p = absolute pressure in inches of mercury, = 29.92 for ordinary atmospheric pressure.

OXYGEN AND AIR REQUIRED FOR THE COMBUSTION OF CARBON, HYDROGEN, ETC.

| | Chemical Reaction. | Lbs. O per lb. fuel. | Lbs. N = 3.32 x O. | Air per lb. = 4.32 x O. | Gaseous product per lb. |
|---|--|----------------------|--------------------|-------------------------|-------------------------|
| Carbon to CO ₂ | C + 2O = CO ₂ | 2 $\frac{3}{8}$ | 8.85 | 11.52 | 12.52 |
| Carbon to CO | C + O = CO | 1 $\frac{3}{8}$ | 4.43 | 5.76 | 6.76 |
| Carbon monoxide to CO ₂ | CO + O = CO ₂ | $\frac{1}{2}$ | 1.90 | 2.47 | 3.47 |
| Hydrogen to H ₂ O | H + O = H ₂ O | 8 | 26.56 | 34.56 | 35.56 |
| Methane, CH ₄ to CO ₂ } and H ₂ O | CH ₄ + 2O = CO ₂ + 2H ₂ O | 4 | 13.28 | 17.28 | 18.38 |
| Sulphur to SO ₂ | SO ₂ + S + 2O = SO ₂ | 1 | 3.33 | 4.32 | 5.32 |

DENSITIES OF GASES.

| Name. | Symbol. | Specific Gravity. Air = 1. | Wt. of 1 litre. Grams. | Wt. of 1 cu. ft. Lb. | Relative Density. H = 1. | Do., ap- proximate figures. |
|---------------------|-------------------------------|-------------------------------|------------------------------|----------------------------|--------------------------------|-----------------------------------|
| Oxygen..... | O | 1.10521 | 1.43003 | 0.88843 | 15.96 | = 16 |
| Nitrogen | N | 0.9701 | 1.25523 | 0.78314 | 14.01 | = 14 |
| Hydrogen | H | 0.069234 | 0.089582 | 0.05589 | 1 | = 1 |
| Carbon dioxide..... | CO ₂ | 1.51968 | 1.96633 | 1.22681 | 21.95 | = 22 |
| Carbon monoxide.... | CO | 0.96709 | 1.25133 | 0.78071 | 13.97 | = 14 |
| Methane | CH ₄ | 0.55297 | 0.71549 | 0.44640 | 7.99 | = 8 |
| Ethylene..... | C ₂ H ₄ | 0.96744 | 1.25178 | 0.78100 | 13.97 | = 14 |
| Acetylene | C ₂ H ₂ | 0.89820 | 1.16219 | 0.73010 | 12.97 | = 13 |
| Sulphur dioxide.... | SO ₂ | 2.21295 | 2.86336 | 1.78646 | 31.96 | = 32 |
| Air | | 1 | 1.2939 | .080728 | | |

The first two columns of figures are from Hempel's Gas Analysis, credited therein to Landolt and Börnstein's *Physikalisch-chemische Tabellen*. The litre weights are referred to Berlin. The weights per cubic foot are based on the weight of air given by Rankine, 0.080728 lb. per cu. ft. at 32° F. and atmospheric pressure, and the figures in the column of specific gravities.

Heating Values of Various Substances.—The following table gives the heating values of different pure fuels, as determined by burning them in oxygen in a calorimeter:

HEAT OF COMBUSTION OF VARIOUS SUBSTANCES IN OXYGEN.

| | Heat-units. | | Authority. |
|---|-------------|--------|-----------------------|
| | Cent. | Fahr. | |
| Hydrogen to liquid water..... | 34,462 | 62,032 | Favre and Silbermann. |
| Carbon (wood charcoal) to carbon | 34,342 | 61,816 | Thomsen. |
| dioxide, CO ₂ | 8,080 | 14,544 | Favre and Silbermann. |
| Carbon, diamond to CO ₂ | 8,137 | 14,647 | Berthelot. |
| “ black diamond to CO ₂ | 7,859 | 14,146 | “ |
| “ graphite to CO ₂ | 7,861 | 14,150 | “ |
| Carbon to carbon monoxide, CO.... | 7,901 | 14,222 | “ |
| CO to CO ₂ , per unit of CO..... | 2,473 | 4,451 | Favre and Silbermann. |
| O to CO ₂ , per unit of C, = 2½ × 2403 | 2,403 | 4,325 | “ |
| Methane (marsh-gas), CH ₄ to CO ₂ | 2,385 | 4,293 | Thomsen. |
| and H ₂ O..... | 5,607 | 10,093 | Favre and Silbermann. |
| Ethylene (olefiant gas), C ₂ H ₄ to CO ₂ | 13,120 | 23,616 | Thomsen. |
| and H ₂ O..... | 13,063 | 23,513 | Favre and Silbermann. |
| Benzole gas, C ₆ H ₆ to CO ₂ and H ₂ O. | 11,858 | 21,344 | “ |
| Acetylene C ₂ H ₂ | 11,957 | 21,523 | Thomsen. |
| Sulphur | 10,102 | 18,184 | “ |
| | 9,915 | 17,847 | Favre and Silbermann. |
| | 10,109 | 18,196 | Calculated. |
| | 2,250 | 4,050 | N. W. Lord.* |

The heating value of methane, CH₄, if calculated according to its composition by the formula 8080C + 34,462H, using Favre and Silbermann's figures, is 26,416 Centigrade heat-units, instead of 23,513, the value determined by a calorimeter, a difference of 2903 heat-units. The calculated heating value of ethylene, C₂H₄, is 11,849, and that of benzole gas, C₆H₆, is 10,109 heat-units, differing respectively from the calorimetric values only 9 and 7 heat-units.

* See Appendix to this chapter, Heating Value of Sulphur in Coal, p. 35.

In calculations of the heating value of mixed fuels the value for carbon is commonly taken at 14,600 British thermal units, which is approximately the average of the figures given by Favre and Silbermann and by Berthelot, and that of hydrogen at 62,000, which is nearly the average of the figures of Favre and Silbermann and of Thomsen.

Taking the heating value of C burned to CO_2 at 14,600 B.T.U., and that of C to CO at 4450, the difference, 10,150 B.T.U., is the heat lost by the imperfect combustion of each pound of carbon burned to CO instead of CO_2 . If the CO formed by this imperfect combustion is afterwards burned to CO_2 , the lost heat is regained.

Heat Absorbed by Decomposition.—By the decomposition of a chemical compound as much heat is absorbed or rendered latent as was evolved when the compound was formed. If 1 lb. C. is burned to CO_2 , generating 14,600 B.T.U., and the CO_2 thus formed is immediately reduced to CO by passing it through a body of glowing carbon, by the reaction $\text{CO}_2 + \text{C} = 2\text{CO}$, the result is the same as if the 2 lbs. C. had been originally burned to 2CO, generating $2 \times 4450 = 8900$ B.T.U. The 2 lbs. C. burned to CO_2 would generate $2 \times 14,600 = 29,200$ B.T.U., the difference, $29,200 - 8900 = 20,300$ B.T.U., being absorbed or rendered latent in the 2CO, or 10,150 B.T.U. for each pound of carbon.

In like manner if 9 lbs. of water (which might be formed by burning 1 lb. H with the generation of 62,000 B.T.U. and cooling the resulting H_2O to the atmospheric temperature) be injected into a large bed of glowing coal, it will be decomposed into 1 lb. H and 8 lbs. O. The decomposition will absorb 62,000 B.T.U., cooling the bed of coal this amount, and the same quantity of heat will again be evolved if the H is subsequently burned with a fresh supply of O. The 8 lbs. O will enter into combination with 6 lbs. C, forming 14 lbs. CO (since CO is composed of 12 parts C to 16 parts O), generating $6 \times 4450 = 26,700$ B.T.U., and $6 \times 10,150 = 60,900$ B.T.U. will be latent in this 14 lbs. CO, to be evolved later if it is burned to CO_2 with an additional supply of 8 lbs. O.

Heating Value of Compound or Mixed Fuels.—It is customary to consider the heating value of a compound or mixed fuel as being equal to the sum of the heating values of its elementary constituents, and to calculate it by means of Dulong's formula, which is, using approximate figures, in British thermal units,

$$\text{Heating value} = \frac{1}{100} \left[14,600\text{C} + 62,000 \left(\text{H} - \frac{\text{O}}{8} \right) + 4050\text{S} \right];$$

$$\text{or, Heating value} = \frac{1}{100} \left[8140C + 34,400 \left(H - \frac{O}{8} \right) + 2250S \right]$$

in Centigrade units, in which C, H, O, and S are respectively the percentages of carbon, hydrogen, oxygen, and sulphur contained in the fuel. The term $H - \frac{O}{8}$ is called the "available" or "disposable" hydrogen, or that which is combined with oxygen in the fuel.

This formula does not apply in the case of a mixed gaseous fuel containing carbon monoxide, since, as shown in the table given above, 1 lb. C in the form of CO generates when burning to CO₂ only 10,093 B.T.U. instead of 14,544 B.T.U. (Favre and Silbermann's values), the difference, 4451 B.T.U., having already been generated when the CO was formed. The formula also does not appear to hold true in the case of some hydrocarbon gaseous fuels, as in the case of methane, mentioned in the note under the table, while on the other hand it does appear to hold in the case of ethylene and benzole.

For all the common varieties of coal, cannel-coal and some lignites being excepted, it is accurate within the limits of error of chemical analyses and calorimetric determinations, as is shown by the recent experiments of Mahler and of Lord and Haas, which are discussed elsewhere in this volume.

"Available Heating Value" of Hydrogen.—Some writers in giving the heating value of hydrogen subtract from its total calorimetric value, 62,000 B.T.U. (found by burning the gas in a calorimeter in which the steam generated by the combustion is condensed and cooled to the temperature of the water in the calorimeter), a quantity representing the latent heat of the steam generated, viz., 965.7 B.T.U. per lb. steam, or $9 \times 965.7 = 8691.3$ B.T.U. per lb. hydrogen, making the net heating value of hydrogen "burned to steam at 212°" $62,000 - 8691 = 53,309$ B.T.U. per lb. Others subtract also an additional quantity representing the difference between the heat in the 9 lbs. of water condensed from the steam at 212° and that in the same water when cooled down to a given standard temperature, such as 62°. This difference is 150.9 B.T.U. per lb. water, or $9 \times 150.9 = 1358.1$ B.T.U. per lb. hydrogen, which subtracted from 53,309 gives 51,951 B.T.U. as the available heating value of 1 lb. hydrogen burned with 8 lbs. oxygen, both gases being supplied at 62°, and the product, 9 lbs. H₂O, escaping as steam at 212°.

This use of heating values of hydrogen "burned to steam," in computations relating to combustion of fuel, is inconvenient, since it

necessitates a statement of the conditions upon which the figures are based; and it is, moreover, misleading, if not inaccurate, since hydrogen in fuel is not often burned in pure oxygen, but in air, the temperature of the gases before burning is not often the assumed standard temperature, and the products of combustion are rarely discharged at 212°. In steam-boiler practice the chimney-gases are usually discharged at a temperature above 300°; but if economizers are used, and the water supplied to them is cold, the gases may be cooled to below 212°, in which case the steam in the gases is condensed and its latent heat of evaporation is utilized.

If there is any need at all of using figures of the "available" heating value of hydrogen, or of its heating value when "burned to steam," the fact that the gas is burned in air and not in pure oxygen should be taken into consideration. The resulting figures will then be much lower than those above given, and they will vary with different conditions, as shown below.

(1) Suppose 1 lb. H to be burned in just enough air to supply 8 lbs. O, that the H and the air are supplied at 62°, and the products of combustion escape at 212°. - We have:

| | |
|---|---------------|
| Total heating value of 1 lb. H..... | 62,000 B.T.U. |
| Heat lost, latent heat of 9 lbs. H ₂ O at 212°.... = | 8691 |
| 9 lbs. H ₂ O heated from 62° to 212°..... = | 1358 |
| Nitrogen with 8 lbs. O heated from 62° to 212° | |
| = 8 × 3.32 × 150 × 0.2438 (specific heat) = | 971 |
| | 11,020 |
| Net available heating value..... | 50,980 |

(2) Suppose that the air-supply is double that required to effect the combustion of the H, other conditions being the same as in (1). The additional heat lost will be:

$$\begin{aligned} \text{Excess air } 8 \times 4.32 &= 34.56 \text{ lbs.} \times 150 \times 0.2375 \dots = 1,231 \text{ B.T.U.} \\ \text{Which will reduce the net heating value to} \dots \dots \dots & 49,749 \quad \text{"} \end{aligned}$$

(3) Suppose that with the double air-supply the products of combustion escape at 562°. The heat lost will then be as below:

| | |
|--|--------------|
| 9 lbs. water heated from 62° to 212°..... | 1,358 B.T.U. |
| Latent heat of 9 lbs. H ₂ O at 212°..... | 8,691 |
| Superheated steam, 9 lbs. × (562 - 212) × 0.48 (sp. ht.) | 1,512 |
| Nitrogen, 26.56 × (562 - 62) × 0.2438..... | 3,238 |
| Excess air, 34.56 × (562 - 62) × 0.2375..... | 4,104 |
| | 18,902 |
| Total losses..... | 18,902 |

Which subtracted from 62,000 gives 41,098 B.T.U. as the net available heating value.

It is better in all calculations of the heating value of fuel, and of the results of combustion in steam-boiler practice, to avoid the use of this so-called "available heating value," and to take the heating value of hydrogen (or that part of the hydrogen which is not already combined with oxygen in the fuel) at 62,000 B.T.U. The various heat losses, calculated as above, which vary with the conditions, are then not subtracted from the heating value of the fuel, but are taken as losses of heat in the chimney-gases.

In calculations of the relative commercial value of different fuels containing hydrogen or water, however, account must be taken of the loss of heat due to superheated steam escaping in the chimney-gases.

Available Heating Value of a Fuel containing Hydrogen.—The total heating value of a hydrogenous fuel being

$$14,600C + 62,000\left(H - \frac{O}{8}\right),$$

to find the available heating value for any assumed temperature of the air-supply and of the chimney-gases, we subtract the heat lost in the superheated steam which escapes into the chimney, or

$$9H \times [(212.9 - t) + 965.7 + 0.48(T_c - 212^\circ)],$$

in which t is the temperature of the air-supply and T_c that of the chimney-gases. This calculation takes no account of the nitrogen which is in the air required to burn the hydrogen, nor of the excess air-supply, the loss of heat due to these being considered as part of the loss in the dry chimney-gases, consisting of CO_2 , CO , O , and N . (The figures 212.9 and 965.7 are usually taken as 212 and 966 with sufficient accuracy.)

EXAMPLE.—What is the total heating value and the available heating value of 1 lb. of combustible consisting of $0.91C + .05H + .04O$, the air for combustion being supplied at 62° and the chimney-gases escaping at 562° ?

| | |
|---|-----------------|
| Total heating value, $0.91 \times 14,600 + .045 \times 62,000$ | = 16,076 B.T.U. |
| Heat lost in steam, $9 \times .05[150 + 966 + (0.48 \times 350)]$ | = 578 " |
| Difference, or available heating value..... | <u>15,498</u> " |

The heat lost in the steam is about 3.5% of the total heating value.

Available Heating Value of a Fuel containing Hydrogen and Water.—In this case the heat lost includes, besides that due to the

superheated steam formed by the combustion of the available hydrogen, that is, the hydrogen of the dry fuel less one-eighth of the oxygen of the dry fuel, the heat due to the superheated steam formed from the water in the fuel, or

$$(9H + W) \times [(212 - t) + 966 + 0.48(T_c - 212)],$$

in which W is the water in 1 lb. of the fuel.

EXAMPLE.—What is the available heating value of 1 lb. of moist wood whose analysis is 38C, 5H, 32O, 1 ash, 24 water, = 100%, the air being supplied at 62° F. and the chimney-gas escaping at 412° ?

Total heating value, $38 \times 14,600 + (5 - 4) \times 62,000$ = 6168 B.T.U.

Heat lost in superheated steam, $(9 \times .05 + 0.24)$

$$\times [150 + 966 + (0.48 \times 200)] \dots\dots\dots = 836 \quad "$$

$$\text{Available heating value} \dots\dots\dots = \underline{5332} \quad "$$

The heat lost in the steam in this case is nearly 14% of the total heating value.

Temperature of the Fire.—Assuming that a pure fuel, such as carbon, is thoroughly burned in a furnace, all of the heat generated will be transferred to the gaseous products of combustion, raising their temperature above that at which the fuel and the oxygen or air are supplied to the furnace. Suppose that 1 lb. C is burned with $2\frac{2}{3}$ lbs. O, forming $3\frac{2}{3}$ lbs. CO_2 , both the C and the O being supplied at 0° F. The combustion of the 1 lb. C generates 14,600 B.T.U., which will all be contained in the $3\frac{2}{3}$ lbs. CO_2 . The specific heat of CO_2 is 0.217; that is, it requires 0.217 B.T.U. to raise the temperature of CO_2 one degree Fahrenheit. To raise $3\frac{2}{3}$ lbs. CO_2 one degree will require $3\frac{2}{3} \times 0.217 = 0.7957$ B.T.U., and 14,600 B.T.U. will therefore raise its temperature $14,600 \div 0.7957 = 18,350^\circ$ F. above the temperature at which the C and the O were supplied. The temperatures thus calculated are known as theoretical temperatures, and are based on the assumptions of perfect combustion and no loss by radiation. The temperature of $18,350^\circ$ is far beyond any temperature known in the arts, and it is probable that long before it could be reached the phenomenon of dissociation would take place; that is, the CO_2 would be split up into C and O, and the elements would lose their affinity for each other.

The theoretical elevation of temperature of the fire may conveniently be calculated by the formula

$$\text{Elevation of temp.} = \frac{\text{B.T.U. generated by the combustion}}{\text{Weight of gaseous products} \times \text{their specific heat}}$$

| | | | | | | |
|--|--------|--------|--------|-------|-------|-------|
| Air-supply below 11.52 lbs., per cent.. | 0 | 10 | 20 | 30 | 40 | 50 |
| Air per lb. C, lbs..... | 11.52 | 10.37 | 9.22 | 8.06 | 6.91 | 5.76 |
| Air + C = gas, lbs.... | 12.52 | 11.37 | 10.23 | 9.06 | 7.91 | 6.76 |
| C burned to CO ₂ , per cent..... | 100 | 80 | 60 | 40 | 20 | 0 |
| C " " CO " " | 0 | 20 | 40 | 60 | 80 | 100 |
| Heat generated in making CO ₂ , B.T.U. | 14,600 | 11,680 | 8,760 | 5,840 | 2,920 | 0 |
| " " " " CO " " | 0 | 890 | 1,780 | 2,670 | 3,560 | 4,450 |
| Total heat generated..... | 14,600 | 12,570 | 10,540 | 8,510 | 6,480 | 4,450 |
| Elevation of temperature of fire (taking specific heat of gases at 0.24) } | 4860° | 4606° | 4298° | 3914° | 3418° | 2743° |

TEMPERATURE OF THE FIRE, CARBON BURNED TO CO₂ WITH EXCESS OF AIR.

| | | | | | | |
|--|-------|-------|-------|-------|-------|-------|
| Air-supply above 11.52 lbs., per cent. | 25 | 50 | 75 | 100 | 150 | 200 |
| Air per lb. C, lbs..... | 14.40 | 17.28 | 20.16 | 23.04 | 28.80 | 34.56 |
| Air + C = gas, lbs | 15.40 | 18.28 | 21.16 | 24.04 | 29.80 | 35.56 |
| Elevation of temperature of fire | 3950° | 3328° | 2875° | 2530° | 2041° | 1711° |

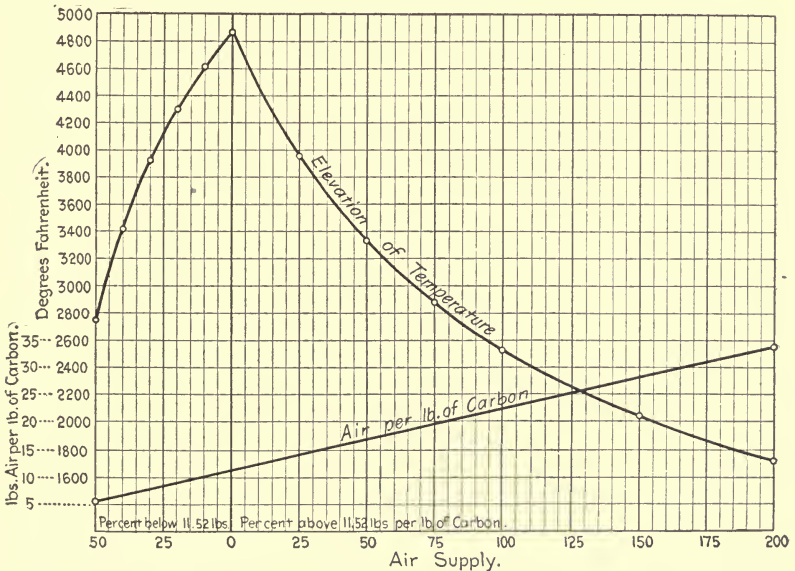

FIG. 1.—MAXIMUM THEORETICAL TEMPERATURE OF THE FIRE DUE TO BURNING CARBON WITH DIFFERENT QUANTITIES OF AIR.

(For the two tables given above and for the diagram plotted therefrom the author is indebted to Mr. H. T. De Puy of the Babcock & Wilcox Co.)

CARBON BURNED PART TO CO₂ AND PART TO CO WITH EXCESS OF AIR.

| | | | | | | |
|---|-------|-------|-------|-------|-------|-------|
| C burned to CO ₂ , per cent..... | 100 | 80 | 60 | 40 | 20 | 0 |
| C " " CO " " | 0 | 20 | 40 | 60 | 80 | 100 |
| Excess of air " " | 50 | 40 | 30 | 20 | 10 | 0 |
| Air + C = gas, lbs..... | 18.28 | 15.52 | 12.99 | 10.67 | 8.60 | 6.76 |
| Elevation of temperature of fire..... | 3328° | 3375° | 3350° | 3323° | 3139° | 2743° |

Maximum Theoretical Temperature due to Burning Hydrogen in Dry Air.—1 lb. H burned to H_2O generates 62,000 B.T.U. The products of combustion are 9 lbs. H_2O (superheated steam) and $8 \times 3.32 = 26.56$ lbs. N. Let t = temperature of the atmosphere and $T + t$ = temperature of the products of combustion, 0.48 = specific heat of superheated steam, and 0.2438 = specific heat of nitrogen. Then

$$62,000 = 9[(212.9 - t) + 965.7 + 0.48(T + t - 212)] + 26.56 \times 0.2438T.$$

212.9 is the B.T.U. above 0° F. in 1 lb. of water at 212° , 965.7 is the latent heat of evaporation at 212° , and $0.48(T + t - 212)$ is the heat required to heat 1 lb. of steam from 212° to the temperature $T + t$.

Taking t at 62° , we have

$$\begin{aligned} 62,000 &= 9[1044.6 + 0.48T] + 6.475T \\ &= 9401.4 + 10.795T. \end{aligned}$$

Whence $T = 4872.5$, and $T + t = 4934.5^\circ$ F.

The term $(212.9 - t)$ is usually written $(212 - t)$; the difference is unimportant, causing less than 1° F. error in the result.

The maximum theoretical temperature due to burning hydrogen in air and that due to burning carbon in air are very nearly the same.

Temperature of the Fire, the Fuel containing Hydrogen and Water.—The gaseous products of combustion in this case will contain superheated steam, formed from the combustion of the hydrogen in the coal and the evaporation of the moisture. The calculation of the temperature of the fire, assuming perfect combustion and no loss by radiation, may be made in the following manner. Reduce the analysis of the fuel in percentages of C, H, O, and moisture to decimal parts of 1 lb.

Let $H_1 = H - \frac{1}{8}O$ = available hydrogen;

W = moisture in the coal;

T = elevation of the temperature of the fire above the atmospheric temperature;

t = temperature of the atmosphere, say 60° F.;

L = latent heat of evaporation at $212^\circ = 966$;

a = heating value of 1 lb. of carbon = 14,600;

b = " " " 1 lb. of hydrogen = 62,000;

f = lbs. of dry gas per lb. of carbon = $CO_2 + N +$ excess air;

c = specific heat of the gas = 0.237;

$9H$ = lbs. of steam formed by burning the available H ;

$W + 9H$ = superheated steam in the gases;

0.48 = specific heat of superheated steam.

The total heat developed by burning 1 lb. of the fuel will be $aC + bH_1$ heat-units.

All of this heat will be utilized in raising the temperature of the gas and steam to T° above the atmosphere. The dry gas will contain cT heat-units, and the superheated steam

$$(W + 9H)[212 - t + L + 0.48(T + t - 212)].$$

We have then

$$aC + bH_1 = 0.237fT + (W + 9H)[212.9 - t + L + 0.48(T + t - 212)] \\ = [0.237f + 0.48(W + 9H)]T + (W + 9H)(1077 - 0.52t).$$

Transposing,

$$T = \frac{aC + bH_1 - (W + 9H)(1077 - 0.52t)}{0.237f + 0.48(W + 9H)}.$$

Substituting for a , b , and H_1 their values, and taking $t = 62^\circ$,

$$T = \frac{14,600C + 62,000(H - \frac{1}{3}O) - 1044.6(W + 9H)}{0.237f + 0.48(W + 9H)}.$$

Taking C , H , O , and W in percentages, instead of in decimal parts, the formula reduces to (a very close approximation)

$$T = \frac{616C + 2220H - 327O - 44W}{f + 0.02W + 0.18H}.$$

EXAMPLES.—1. Given a coal whose analysis, excluding ash and sulphur, is 75C, 5H, 10O, and 10 moisture, with dry gas = 20 lbs. per lb. of this combustible, including moisture:

$$T = \frac{616 \times 75 + 2220 \times 5 - 327 \times 10 - 44 \times 10}{20 + .02 \times 10 + .18 \times 5} = 2538^\circ; \\ T + t = 2600^\circ \text{ F.}$$

The first of the two formulæ gives 2602° F.

The sulphur in coal may be neglected in calculations of temperature, since 3 per cent of sulphur would not increase the temperature one per cent, taking 4000 B.T.U. as the heating value of sulphur. The error due to neglecting it is less than the probable error of the figure, 0.237, for the specific heat of furnace-gases at high temperatures.

2. Required the maximum temperature attainable by burning moist wood of the composition C, 38; H, 5; O, 32; ash, 1; moisture, 24; the dry gas being 15 lbs. per lb. of wood, and the temperature of the atmosphere 62° .

$$T = \frac{616 \times 38 + 2220 \times 5 - 327 \times 32 - 44 \times 24}{15 + .02 \times 24 + 0.18 \times 5} = 1403^\circ; \\ T + t = 1465^\circ.$$

3. Since the carbon and the available hydrogen make only 39% of the weight of the wood, a much smaller air-supply than that required to make 15 lbs. of dry gas per lb. of wood may be sufficient to effect complete combustion. If we take the dry gas at 10 lbs. instead of 15, the temperature T will be

$$T = \frac{22988}{10 + 1.38} = 2020^\circ.$$

4. Required the theoretical temperature of a fire of Pocahontas coal of the following analysis: C, 84.22; H, 4.26; O, 3.48; N, 0.84; S, 0.59; ash, 5.85; water, 0.76; the dry gas being 20 lbs. per lb. of combustible, the heating value of the S being neglected.

The combustible, C, H, O, and N, is 92.80% of the coal;

$$f = 20 \times .928 = 18.56.$$

$$T = \frac{616 \times 84.22 + 2220 \times 4.26 - 327 \times 3.48 - 44 \times 0.76}{18.56 + .02 \times 0.76 + .18 \times 4.26} = 3110^\circ;$$

$$T + t = 3110 + 62^\circ = 3172^\circ.$$

Pure carbon burned with 19 lbs. air per lb., making 20 lbs. of gas, by the same formula gives $T = 3080$, $T + t = 3142$. The semi-bituminous coal therefore gives a trifle higher temperature than pure carbon.

Actual Temperature of the Fire usually Less than the Theoretical.— In order to realize in practice the temperatures given by the above theoretical calculations, it is necessary that the air be delivered to the incandescent fuel at a perfectly uniform rate; that the combustion of the hydrogen be complete; that the combustion of the carbon be complete, forming CO_2 , when the air-supply equals or exceeds 11.52 lbs per lb. of carbon burned, or, when the air-supply is less than this, that all of its oxygen be used to form either CO or CO_2 ; and that there be no loss by radiation from the incandescent fuel into the surrounding furnace or boiler walls. These conditions can be nearly obtained under some circumstances, such, for instance, as with gaseous fuel with an intimate and regular admixture of air, the combustion taking place in a chamber with thick fire-brick walls; with dust fuel burned under similar conditions; and with a thick fire of anthracite, egg size, burned in a fire-brick chamber with a steady draft, after the freshly fired upper layer of coal has reached the temperature of the furnace. With insufficient air-supply the actual temperature is always less than the theoretical, for the reason that some of the oxygen passes through the fire

without entering into combination with carbon. Generally the air-supply is not regular, even with a steady draft pressure, for the reason that the freshly fired coal chokes to some degree the air-passages through the bed, causing the formation of some CO and chilling the furnace. When the fire-bed is directly underneath the comparatively cool surface of the boiler, radiation from the bed reduces the furnace temperature.

The author has obtained temperatures exceeding 3000° F., as measured by a Uehling & Steinbart recording pneumatic pyrometer, with Pittsburg coal containing less than 2% of moisture, and having a heating value of 15,000 B.T.U. per lb. of dry combustible. The conditions were a fire-brick combustion-chamber and frequent firing of small quantities of coal at a time. This corresponds nearly to the theoretical temperature due to an air-supply of 19 lbs. per lb. of combustible, which is the figure found in practice to give the highest efficiency of steam-boiler performance.

Excessive Carbon Monoxide produced by Heavy Firing.—A series of experiments by J. C. Hoadley (Trans. A. S. M. E., vol. vi. p. 794), in which for three hours anthracite egg coal was fired on the grates at the rate of 200 lbs. in each half-hour, when the rate at which the coal was burned was only about 140 lbs., thus steadily increasing the thickness of the bed of coal, showed the following results, the gases being analyzed every half-hour:

| Half-hour periods. | 1 | 2 | 3 | 4 | 5 | 6* | 7* | 8 |
|------------------------------|------|------|------|------|------|------|-------|-------|
| CO in gases, per cent.. | 2.54 | 2.99 | 3.99 | 4.61 | 4.70 | 4.81 | 0.25 | 0.21 |
| CO ₂ " " " " ... | 5.12 | 5.55 | 7.79 | 7.70 | 7.82 | 8.01 | 15.21 | 14.11 |
| Lbs. air per lb. coal. . . . | 33.2 | 29.5 | 21.4 | 20.1 | 19.8 | 19.3 | 19.3 | 20.8 |

* Intervals of one hour.

The firing was at the rate of 200 lbs. of coal every half-hour until 11.15 A.M., or fifteen minutes before the sixth sample of gas was taken. The next lot of 200 lbs. coal was not fired until 12.45 P.M., and no more was fired until after the eighth sample of gas was taken. The seventh sample was taken at 12.30, and the eighth at 1.30, each forty-five minutes after firing 200 lbs. of coal. The results show a steady increase in CO up to 11.30 A.M., as the bed of coal became thicker, and a reduction to a low figure when the bed became thin.'

These tests show that it is sometimes possible for a high percentage of CO and a great excess of air-supply to exist at the same time. This may be explained by supposing that the excess of CO was generated at one portion of the grate surface, and that the excess of air entered at another—or else leaked into the boiler-setting beyond the bridge-wall—and that the two currents, one of CO and the other of air, were

never brought into contact until their temperature was reduced below the point of ignition.

Calculation of the Weight of Air supplied, and the Weight of the Gases, from the Analysis of the Gases by Volume.*—Given a coal containing 66C, 5H, 8O, 1N, 8 water, and 12 ash, = 100%, it is required to compute the analysis, by weight and by volume, of the gaseous products of combustion, on the assumptions (1) that 60C is burnt to CO_2 and 6 to CO; (2) that the supply of dry air is 20% in excess of that required to effect this combustion of the C and to burn the available H (= H - $\frac{1}{2}\text{O}$) to H_2O ; and (3) that the dry air is accompanied by 1% of its weight of moisture. It is also required to determine the weight of dry air and of dry gas per lb. of carbon and per lb. of fuel, and furthermore to find formulas by means of which these weights may be computed directly from the analysis of the gases by volume.

We first construct a table in which are shown the elements of the coal and of the air which combine to form the gaseous products, as follows:

| Per cent or parts in 100 lbs. fuel. | O from the air. | N from the air = O \times 3.32. | Total air. | CO_2 . | CO. | H_2O . |
|--|--------------------|--------------------------------------|---------------|-----------------|--------|------------------------|
| 60C to $\text{CO}_2 \times 2\frac{2}{3}$ | = 160 | 531.20 | 691.20 | 220 | .. | .. |
| 6C to CO $\times 1\frac{1}{3}$ | = 8 | 26.56 | 34.56 | ... | 14 | .. |
| 4H to $\text{H}_2\text{O} \times 8$ | = 32 | 106.24 | 138.24 | ... | .. | 36 |
| | <hr/> | <hr/> | <hr/> | | | |
| | 200 | 664.00 | 864.00 | | | |
| 1H } 8O } to H_2O | | | | | | 9 |
| 1 N..... | | 1.00 | | | | |
| 8 water..... | | | | | | 8 |
| 12 ash | | | | | | |
| <hr/> | | | | | | |
| 100 | | | | | | |
| Excess air, 20%..... | 40 | 132.80 | 172.80 | | | |
| <hr/> | | | | | | |
| Total dry air..... | | | 1036.80 | | | |
| Moisture in the air..... | | | | | | 1.04 |
| <hr/> | | | | | | |
| Total gases, 1125.84 = | 40 | 797.8 | | 220 | 14 | 54.04 |
| Total dry gases, 1071.80, or | 3.732 | 74.436 | | 20.526 | 1.306% | by wt. |
| “ “ “ % by vol. | 3.547 | 80.847 | | 14.187 | 1.419 | |
| Total gas 1125.84 + 12 ash = 100 coal + 1036.80 air + 1.04 moisture in air | | | | | | |
| Dry gas per lb. coal 10.718 lbs.; per lb. C = $1071.8 \div 66 = 16.239$ lbs. | | | | | | |
| Dry air per lb. coal 10.368 lbs.; per lb. C = $1036.8 \div 66 = 15.709$ lbs. | | | | | | |

* To convert analysis by volume into analysis by weight, multiply the percentage of each constituent gas by its relative density, viz., CO_2 by 11, O by 8, CO and N each by 7, and divide each product by the sum of the products. *Per contra*, to convert analysis by weight into analysis by volume, divide the percentage by weight of each gas by its relative density, and divide each quotient by the sum of the quotients.

The air and gas per lb. coal and per lb. C may be calculated from the analysis of the gases by weight or by volume, as follows:

Let $\text{CO}_2 + \text{O} + \text{CO} + \text{N} =$ total gas, in percentages, by weight. The carbon in the $\text{CO}_2 = \frac{3}{11}\text{CO}_2$, and that in the $\text{CO} = \frac{3}{7}\text{CO}$. This carbon was supplied by the fuel. We then have

$$\text{Dry gas per lb. C} = \frac{\text{CO}_2 + \text{O} + \text{CO} + \text{N}}{\frac{3}{11}\text{CO}_2 + \frac{3}{7}\text{CO}} = \frac{100}{\frac{3}{11}\text{CO}_2 + \frac{3}{7}\text{CO}}.$$

Multiplying the result by the C in 1 lb. coal gives the dry gas per lb. of coal.

Multiplying each term in this formula by the respective figures for relative density of the several gases, viz., CO_2 , 11; O, 8; CO and N, 7, we obtain

$$\text{Dry gas per lb. C} = \frac{11\text{CO}_2 + 8\text{O} + 7(\text{CO} + \text{N})}{3(\text{CO}_2 + \text{CO})},$$

in which CO_2 , O, CO, and N are percentages by volume. Taking the percentages by volume given in the above table, we have

$$\begin{aligned} \text{Dry gas per lb. C} &= \frac{11 \times 14.187 + 8 \times 3.547 + 7 \times 82.266}{3(14.187 + 1.419)} \\ &= 16.239 \text{ lbs., as before.} \end{aligned}$$

$$\text{Dry gas per lb. coal} = 16.239 \times .66 = 10.718 \text{ lbs.}$$

The 7N in the last formula represents the N supplied by the air, plus the relatively insignificant amount of about 1 part in 800 furnished by the coal, as shown in the table. As the N supplied by the air is 76.85%, or $3.32 \div 432$, of the weight of the air, we have

$$\text{Dry air per lb. C} = \frac{7(\text{N} - \frac{1}{800}\text{N})}{3(\text{CO}_2 + \text{CO})} \times \frac{432}{332} = \frac{3.032\text{N}}{\text{CO}_2 + \text{CO}},$$

in which CO_2 , CO, and N are percentages by volume of the dry gas.

This last formula is a most useful one for computing the air-supply per lb. C from the analysis of the gases by volume. Substituting the percentages found in the example, we have

$$\text{Dry air per lb. C} = \frac{3.032 \times 80.847}{14.187 + 1.419} = 15.707 \text{ lb.,}$$

which is practically the same as the result obtained from the table.*

* If the coal did not contain hydrogen, the dry air per lb. C. might be computed from the $\text{CO} + \text{O} + \text{CO}$, instead of from the N, by means of the formula

$$\text{Dry air per lb. C} = 5.76 \frac{2(\text{CO}_2 + \text{O}) + \text{CO}}{\text{CO}_2 + \text{CO}}.$$

This formula gives inaccurate results when the coal contains hydrogen, for the O

Excess of Air-supply above the Theoretical Minimum Requirement.—Referring to the table of computations in the above example, p. 32, it will be seen that all the nitrogen in the gases, 80.847% by volume, came from the total air-supply, except an insignificant amount furnished by the coal. The oxygen, 3.547%, all came from the excess air-supply. This oxygen was accompanied in the excess air-supply with 3.782 times its volume of nitrogen, or $3.782 \times 3.547 = 13.415N$. The difference between 80.847 and $13.415 = 67.432$ is the N of the air theoretically required to burn the coal, and the quotient, $80.847 \div 67.432 = 1.199$, is the ratio of the total air-supply to that theoretically required. Subtracting 1 from this ratio and multiplying by 100 gives 19.9% as the calculated percentage of excess air-supply, a close approximation to the 20% originally assumed in computing the table. The formula for computing the percentage of excess of air-supply above that theoretically required then is:

$$\text{Per cent excess air} = 100 \times \left(\frac{N}{N - 3.782O} - 1 \right).$$

The ratio of total air to the theoretical requirement is $\frac{N}{N - 3.782O}$, in which N and O are respectively the percentages of N and O by volume in the dry gas.*

of the air required to burn the hydrogen to H_2O does not appear in the analysis of the dry gases. In the example given in the text, the result calculated by this formula would be $5.76 \frac{2(14.187 + 3.547) + 1.419}{14.187 + 1.419} = 13.615$ lb. instead of 15.707 lb. calculated by the correct formula.

This formula is derived as follows: We have found

$$\text{Dry gas per lb. C} = \frac{11CO_2 + 8O + 7CO + 7N}{3(CO_2 + CO)},$$

in which CO_2 , O, CO, and N are percentages by volume. The oxygen in $11CO_2 + 8O + 7CO = 8CO_2 + 8O + 4CO$. The air corresponding to this oxygen = 4.32 times the O, whence

$$\text{Dry air per lb. C} = 4.32 \frac{8(CO_2 + O) + 4CO}{3(CO_2 + CO)} = 5.76 \frac{2(CO_2 + O) + CO}{CO_2 + CO}.$$

* Bunte gives a formula, quoted by Donkin, for the ratio of air in excess of that theoretically required for combustion as follows: Excess ratio = $\frac{18.9}{CO_2}$. Taking the CO_2 in our example, 14.187%, this formula shows the excess air-supply to be 33.3% instead of 20%, the correct figure. It is evident that the CO_2 in the gases is not the proper datum from which to compute the air-supply, for low CO_2 , which by the formula would indicate a large air-supply, may be due to high CO, which is caused by a deficient air-supply.

APPENDIX TO CHAPTER II.

I. HEATING VALUE OF SULPHUR (AS IRON PYRITES) IN COAL.*

A sample of Pocahontas coal having a calorific value of 8062 (calories) and containing 0.57 per cent of sulphur was mixed with pyrites in two proportions, nine of coal to one of pyrites, and eight of coal to two of pyrites. The coal and pyrites were separately reduced to fine powder and then mixed by rubbing in a mortar. The mixtures were then compressed into cylinders for combustion in the bomb [the Mahler calorimeter]. The pyrites used was a selected crystal of FeS_2 .

The results were as follows:

| | |
|--|------------|
| No. 1. Weight of coal mixtures taken | 0.938 gram |
| Actual heat developed after correction for wire burned as fuse | 7129 units |

To calculate the heat due to the production of nitric acid I subtracted the acidity due to the sulphuric acid produced from the total acidity in the bomb-washings and figured the difference as nitric acid. Correcting the figure for heating-power for this gives 7107 units for the heat produced by burning the 0.938 gram of mixture, but this mixture contained $\frac{9}{10}$ coal. The heating value of this coal ($0.9 \times 0.938 \times 8062$) was 6806. $7107 - 6806 = 301$, the heat due to the combustion of the pyrites.

The sulphur was determined in the liquid washed from the bomb. It amounted to 0.0538 gram; or, deducting the 0.0048 in the coal present, 0.0490 sulphur burned as pyrites produced 301 units, which is in the proportion of 6140 units for each unit of sulphur present as iron pyrites in the coal.

A second experiment was conducted in precisely the same manner on the mixture containing eight parts of coal and two parts of pyrites.

| | |
|---|-------|
| | H. U. |
| Heat of combustion of 0.921 gram of the mixture | 6520 |
| Heat due to coal | 6005 |

Heat due to pyrites. 515

Sulphur in bomb-washings as sulphates, 0.1045; present in coal, 0.0042; burned in pyrites, 0.1003; hence this experiment gave 5150 units for the heat due to a unit of sulphur as pyrites.

Of course, these two results do not "check" very well, as all the errors of the test accumulated in the differences found; but it seems safe to conclude that the heat due to the combustion of pyrites in the bomb is somewhere about 5500 units per unit of sulphur. Of course the sulphur is here burned to SO_3 , or rather to dilute H_2SO_4 , and gives more heat than when it burns in air to SO_2 . Pyrites contains 53.3% S. Translating the above result (5500) into heat developed per unit of FeS_2 gives 2931 heat units.

* By Prof. N. W. Lord. Trans. Am. Inst. Mining Engineers, vol. xxvii. 1897, p. 960.

Berthelot gives for the heat of formation of dilute H_2SO_4 what is equivalent to 4388 units per unit of sulphur; and assuming 1582 as the heating value of iron burned to magnetic oxide (Andrews), a calculation for the heating value of pyrites would give:

| | |
|---------------------|------------|
| 0.533 S..... | 2339 |
| 0.467 Fe..... | <u>739</u> |
| Calculated heat ... | 3078 |

The S being burned to dilute H_2SO_4 .

This corresponds to the value found well enough to show that when pyrites burns, the iron and sulphur give nearly the same heat they do when *burned separately in the free state*, which justifies the introduction into Dulong's formula of the sulphur term. As to the number I have adopted in the formula (2250)* for the heat developed when S burns to SO_2 , it was taken as an average of several published figures, and is probably a little too high, but not enough out of the way to affect the results noticeably, especially as the heat due to the combustion of the iron was omitted, which it would appear should have been included, though it would have amounted to very little.

II. HYGROMETRIC PROPERTIES OF COALS.†

Two lines of investigation were undertaken for the purpose of ascertaining the relative qualities of various coals when in the same physical condition with reference to absorbing moisture from the atmosphere:

First, a number of samples of different coals were reduced to a uniform physical condition by grinding or powdering; were then thoroughly dried, and afterward simultaneously exposed to a saturated or nearly saturated atmosphere, for a period of from six to eight days as required, to obtain constant weight. The weight of moisture was determined by taking the difference between the first and final weights, and this result was checked by thoroughly drying and re-weighing.

Second, an investigation was made to determine the effect of the size of particles upon the power to absorb moisture; the investigation being similar in nature to that previously described.

The method of drying in all cases was the same. The coal was heated to a temperature of from 220 to 240 degrees Fahr., and maintained in that condition for one hour.

Results indicate a great difference in the absorptive power of different coals when in the same physical state, but show, however, a striking similarity in this respect of coals which are known to possess similar qualities from the same geographical districts.

* The heat-units in this paper are calories per gram. 2250 calories per gram = 4050 B. T. U. per lb.

† From a paper by Prof. R. C. Carpenter in Trans. A. S. M. E., vol. xviii. p. 938.

The first investigation seemed to indicate that, independent of the physical condition, different coals vary greatly in their hygrometrical properties, and that with few exceptions, the power of absorbing and retaining moisture is less as the calorific value is greater.

Thus the results show that the maximum amount of moisture which would be absorbed by coals powdered so as to pass No. 80 sieve were on the various tests as follows:

- Anthracites.—10 samples, 4.66 to 6.37%; average, 5.60%.
- Eastern Coking Coals.—6 samples, 0.69 to 3.16%; average, 1.92%.
- Illinois and Indiana Coals.—6 samples, 4.65 to 14.10%; average, 9.77%.

The effect of the size of particle is quite decided. The larger the particle the less the weight of moisture which is absorbed. This indicates that the absorptive power is in part due to capillary action of the surface.

In the second investigation the pieces of coal were made as nearly equal as possible considering their irregular shape of definite sizes, having diameters respectively one inch, half inch, quarter inch and powdered so as to pass through sieves of 60 to the inch. In these experiments there were used two samples of anthracite coal, one obtained by breaking up pieces of egg coal, the other pieces of pea coal; two specimens of bituminous coal, one an Illinois coal and the other a Cumberland coking coal. The results of this investigation, given below, show an increase in absorptive power as the size of the particle is diminished.

| | Size | 1 in. | ½ in. | ¼ in. | Fine. |
|----------------------------|------|-------|-------|-------|-------|
| Illinois..... | | 4.55 | 5.80 | 5.26 | 9.30 |
| Cumberland..... | | 2.17 | 3.76 | 5.61 | 6.42 |
| Lehigh anthracite egg..... | | 1.39 | 2.03 | 2.55 | 5.95 |
| “ “ pea..... | | .62 | .66 | 1.31 | 1.59 |

The results are slightly irregular, due probably to irregularities in the samples selected, but the variation, however, is no more than would probably be found in the selection of samples.

In connection with the drying of coals at temperatures above the boiling point a number of experiments were made to determine whether there was any sensible loss of volatile matter, but so far as could be determined by repeated trials alternately drying and moistening and by varying time of drying from one to three hours, no loss of volatile matter could be detected, and it seems exceedingly probable that no loss of importance occurs at temperatures below 300 degrees Fahr.

For this reason it would seem entirely safe to use this method of drying coals in testing-boilers, as it is easily applied, and has given very satisfactory and uniform results for the writer whenever used.

CHAPTER III.

COAL.

Coal and Social Progress.—The greatest social phenomenon of the nineteenth century is the increase of wealth of the people. According to Mulhall the average wealth per capita in the United States increased from \$230 in 1840 to \$1039 in 1890. A few years ago (about 1895) he said: "The accumulation of wealth in the United States averages \$7,000,000 daily."

Coal is the principal natural agent whose use, through the medium of the steam-engine and of machinery driven by it, has been the cause of the difference between the material civilization of the latter part of the nineteenth century and that of all the centuries that preceded it. It is only since man has learned how to use coal to do his work that he has been enabled to store up wealth in such vast amounts as he is doing at the present time. Man remained poor throughout all the earlier ages because he had not learned how to make use of this one of Nature's most important gifts.

A few hundred years ago he learned how to use it instead of wood and charcoal to keep himself warm and to fashion tools in the blacksmith's forge. Only two hundred years ago, or in 1698, Savery invented an engine by means of which coal was made to pump water, but this engine never caused the turning of a wheel until 1766, and then only by pumping water which was used to turn a water-wheel. In 1705 Newcomen invented his engine, but so far as is known it was used only as a direct-acting pump, and never turned a wheel. It was not until 1781 that James Watt patented his first rotative engine, the first that contained all the essential elements of an engine capable of furnishing the motive power of a factory, and it was five years later before he built his first successful pair of engines, 50 H.P. each, for driving a flour-mill. Not until 1807 did Fulton complete the first commercially successful steamboat, and not until 1829 did Stephenson perfect his locomotive.

The great function of the steam-boiler and engine is the utilization of coal to run machinery, and the result of the invention of the steam-engine is the civilization and the wealth of the race at the end of the nineteenth century.

Production of Coal in the United States.—The amount of coal mined in the United States in 1880 was 65,757,140 gross tons; in 1890, 139,351,438 gross tons, according to the figures of the census in those years; and in 1899, 225,103,024 gross tons, or 252,115,387 net tons, according to "The Mineral Industry." The production in the several States in 1899 and the value at the mines are given in the table on page 40.

To the value of coal at the mine, averaging \$1.10 per ton according to the table on page 40, must be added the freight charge to obtain its cost to the consumer. If this charge averages \$1.00 per ton, probably too low a figure, it makes the total cost of coal consumed in the United States over 500 millions of dollars per annum.

Formation of Coal.—According to the geologists a piece of coal was many thousands of years ago a mass of damp vegetable fibre, a portion of a peat-bog. Half of its weight, approximately, was water, and the other half would contain, by analysis, about 50% carbon, 6% hydrogen, 40% oxygen, 1% nitrogen, and 2% ash. During successive geologic ages the peat-bog was submerged and overlaid with mud, which hardened into slate. This was covered with glacial and alluvial drift, and it may have been tilted and upheaved by volcanic action or subsidence of the earth's crust. It was subjected to great pressure and high temperature, and underwent a more or less complete destructive distillation under pressure.

The conditions under which the distillation of the peat-bogs took place were not alike in different parts of the world. The variable factors were time, depth and porosity of the overlying strata, pressure and temperature, disturbance of the beds by floods and by intrusion into them of minerals, such as carbonate of lime held in solution, or clay, sand, iron, and sulphur. Therefore the product of the distillation varies in different locations all the way from the original peat through brown coal or lignite, bituminous and semi-bituminous coal, semi-anthracite and anthracite, to graphitic coal. The last-named, which is found in Rhode Island, has nearly all the volatile hydrocarbon gases and oxygen driven off from it, leaving practically only fixed carbon and ash, the carbon being in a form which is so hard to burn that the coal is not used as a commercial fuel: while the first, lignite, is only one remove from the peat or woody fibre, retaining perhaps a third of the

TOTAL PRODUCTION OF COAL IN THE UNITED STATES (IN TONS OF 2000 LBS.).

| States. | 1899. | | |
|-----------------------|-------------|----------------|----------|
| | Tons. | Value at Mine. | |
| | | Total. | Per Ton. |
| Bituminous: | | | |
| Alabama..... | 7,484,763 | \$7,484,763 | \$1.00 |
| Alaska (b)..... | 2,300 | 12,282 | 5.34 |
| Arkansas..... | a913,743 | 1,233,553 | 1.35 |
| California..... | 167,161 | 430,631 | 2.58 |
| Colorado..... | 4,747,812 | 8,308,671 | 1.75 |
| Georgia..... | 203,775 | 183,081 | 0.90 |
| Illinois..... | a23,434,445 | 18,443,946 | 0.78 |
| Indiana..... | 6,158,224 | 5,542,402 | 0.90 |
| Indian Territory..... | a1,404,442 | 2,106,663 | 1.50 |
| Iowa..... | 4,675,000 | 5,937,350 | 1.27 |
| Kansas..... | 4,096,895 | 5,124,248 | 1.25 |
| Kentucky..... | 4,668,800 | 3,720,100 | 0.80 |
| Maryland..... | 5,080,248 | 4,318,211 | 0.85 |
| Michigan..... | 500,000 | 720,000 | 1.44 |
| Missouri..... | a3,191,811 | 3,582,111 | 1.12 |
| Montana..... | 1,409,882 | 2,227,998 | 1.58 |
| Nebraska..... | 1,000 | 3,000 | 3.00 |
| New Mexico..... | a1,049,034 | 1,600,588 | 1.52 |
| North Carolina..... | 26,994 | 37,792 | 1.40 |
| North Dakota (b)..... | 120,597 | 120,597 | 1.00 |
| Ohio..... | 16,695,949 | 14,191,557 | 0.85 |
| Oregon..... | 86,886 | 232,854 | 2.68 |
| Pennsylvania..... | 73,066,943 | 57,722,885 | 0.79 |
| Tennessee..... | 3,736,134 | 3,706,617 | 0.99 |
| Texas (c)..... | 940,622 | 1,646,088 | 1.75 |
| Utah..... | 882,496 | 1,553,193 | 1.76 |
| Virginia..... | 2,111,391 | 1,372,404 | 0.65 |
| Washington (d)..... | 1,917,607 | 3,355,812 | 1.75 |
| West Virginia..... | a18,201,189 | 11,830,773 | 0.65 |
| Wyoming..... | 4,525,207 | 5,656,509 | 1.25 |
| Total bituminous..... | 191,501,350 | \$172,406,679 | \$0.90 |
| Cannel: | | | |
| Kentucky..... | 36,630 | \$91,597 | \$2.50 |
| Anthracite: | | | |
| Colorado..... | 59,067 | \$162,434 | \$2.75 |
| Pennsylvania..... | 60,518,331 | \$103,486,346 | 1.71 |
| Total anthracite..... | 60,577,398 | \$103,648,780 | \$1.71 |
| Grand total coal..... | 252,115,387 | \$276,147,056 | \$1.10 |

(a) Fiscal year. (b) All lignite. (c) One-third lignite. (d) One-half lignite.

water, and a large part of the original hydrocarbon, or rather oxyhydrocarbon, since it contains a large percentage of oxygen. The progressive change in chemical analysis, from wood to coal, is shown in the two following tables:

DIMINUTION OF H AND O IN SERIES FROM WOOD TO ANTHRACITE.*

| Substance. | Carbon. | Hydrogen. | Oxygen. |
|--|---------|-----------|---------|
| Woody fibre..... | 52.65 | 5.25 | 42.10 |
| Peat from Vulcaire..... | 59.57 | 5.96 | 34.47 |
| Lignite from Cologne..... | 66.04 | 5.27 | 28.69 |
| Earthy brown coal | 73.18 | 5.58 | 21.14 |
| Coal from Belestat, secondary..... | 75.06 | 5.84 | 19.10 |
| Coal from Rive de Gier..... | 89.29 | 5.05 | 5.66 |
| Anthracite, Mayenne, transition formation..... | 91.58 | 3.96 | 4.46 |

PROGRESSIVE CHANGE FROM WOOD TO GRAPHITE. †

| | Wood. | Loss. | Lignite. | Loss. | Bit. Coal. | Loss. | Anthracite. | Loss. | Graphite. |
|-------------|--------------|--------------|--------------|--------------|--------------|-------------|--------------|-------------|--------------|
| Carbon..... | 49.1 | 18.65 | 30.45 | 12.35 | 18.10 | 3.57 | 14.53 | 1.42 | 13.11 |
| Hydrogen .. | 6.3 | 3.25 | 3.05 | 1.85 | 1.20 | 0.93 | 0.27 | 0.14 | 0.13 |
| Oxygen..... | 44.6 | 24.40 | 20.20 | 18.13 | 2.07 | 1.32 | 0.65 | 0.65 | 0.00 |
| | <u>100.0</u> | <u>46.30</u> | <u>53.70</u> | <u>32.33</u> | <u>21.37</u> | <u>5.82</u> | <u>15.45</u> | <u>2.21</u> | <u>13.24</u> |

* Groves and Thorpe's Chemical Technology, vol. i. Fuels, p. 58.

† J. S. Newberry in Johnson's Cyclopædia.

We thus have different varieties of coal, due to differences in the extent to which the volatile gases have been driven off from the original peat or other woody coal-forming substance. There are also differences in quality in each variety, due to varying percentages of ash and water. The ash, or earthy matter, in coal ranges from 2 to over 30 per cent in different localities. The water ranges from less than 1% in the anthracites up to 14% or more in some Illinois coals and to 25% or more in some lignites. This water seems to be held by capillary attraction, or some similar force, within the particles of a piece of apparently dry coal, so that it cannot all be driven off without heating it to a temperature considerably higher than 212° F., say 250° to 280° F. The bituminous coals are hygroscopic, like wood;* that is,

* Note on the Hygroscopicity of Wood (from Johnson's Materials of Construction, p. 224).—Kept on a shelf in an ordinary dwelling, wood still retains 8 to 10 per cent of its weight of water. Nor is the amount of water in dry wood constant; the weight of a handful of shavings varies with the time of day, being on a summer day greatest in the morning and least in the afternoon.

Desiccating the air with chemicals will cause the wood to dry, but wood thus dried at 80° F. will still lose water in the kiln. Wood dried at 120° F. loses water still if dried at 200° F., and this again will lose more water if the temperature is raised. Absolutely dry wood cannot be obtained; chemical destruction sets in before all water is driven off.

On removal from the kiln the wood at once takes up water from the air, even in the driest weather. At first the absorption is quite rapid; at the end of a week a short piece of pine, 1½ in. thick, has regained two-thirds of, and in a few months all, the moisture it has when air-dry, 8 to 10 per cent, and also its former dimensions.

they absorb moisture from the atmosphere, and the quantity they will contain depends not only on the nature of the coal, but on the relative humidity of the atmosphere, which changes from day to day.

Classification of Coal.—It is convenient to classify the several varieties of coal according to the relative percentages of carbon and volatile matter contained in their combustible portion as determined by proximate analysis. The following is such a classification:

| | Fixed Carbon. | Volatile Matter. | Heating Value per lb. Combustible. | Relative Value of Combustible Semi-bit. = 100. |
|----------------------|---------------|------------------|------------------------------------|--|
| Anthracite..... | 97 to 92.5 | 3 to 7.5 | 14,600 to 14,800 | 93 |
| Semi-anthracite.... | 92.5 to 87.5 | 7.5 to 12.5 | 14,700 to 15,000 | 94 |
| Semi-bituminous.... | 87.5 to 75 | 12.5 to 25 | 15,500 to 16,000 | 100 |
| Bituminous, Eastern. | 75 to 60 | 25 to 40 | 14,800 to 15,200 | 95 |
| “ Western | 65 to 50 | 35 to 50 | 13,500 to 14,800 | 90 |
| Lignite | under 50 | over 50 | 11,000 to 13,500 | 77 |

The locations in which the several classes of coal are found are described in some detail in the chapter on Coal-fields of the United States. The anthracites, with some unimportant exceptions, are confined to three small fields in eastern Pennsylvania. The semi-anthracites are found in a few small areas in the western part of the anthracite field. The semi-bituminous coals are found in a narrow strip of territory, 20 miles wide or less, on the eastern border of the great Appalachian coal-field, extending from north-central Pennsylvania across the southern boundary of Virginia into Tennessee, a distance of over 300 miles.

It is a peculiarity of these semi-bituminous coals that their combustible portion is of remarkably uniform composition, the volatile matter usually ranging between 18 and 22 per cent of the combustible, and approaching in its analysis marsh-gas, CH_4 , with very little oxygen. They are usually low also in moisture, ash, and sulphur, and rank among the best steam-coals in the world. The Eastern bituminous coals occupy the remainder of the Appalachian coal-field, from Pennsylvania and eastern Ohio to Alabama. They are higher in volatile matter, ranging from 25 to over 40 per cent, the higher figures in the western portion of the field. The volatile matter is of lower heating value, being higher in oxygen. The Western bituminous coals and lignites are found in most of the States west of Ohio. They are higher in volatile matter and in oxygen and moisture than the bituminous coals of the Appalachian field, and usually give off a denser smoke when burned in ordinary furnaces.

Caking and Non-caking Coals.—Bituminous coals are sometimes classified as caking and non-caking coals, according to their behavior when subjected to the process of coking. The former undergo an incipient fusion or softening when heated, so that the fragments coalesce and yield a compact coke, while the latter (also called free-burning) preserve their form, producing a coke which is only serviceable when made from large pieces of coal, the smaller pieces being incoherent. The reason of this difference is not clearly made out, as non-caking coals are often of very similar ultimate chemical composition to those in which the caking property is very highly developed. It is found that caking coals lose that property when exposed to the air for a lengthened period, or by heating to about 570° F., and that the dust or slack of non-caking coal may, in some instances, be converted into a coherent cake by exposing it suddenly to a very high temperature. Some coals which cannot be made into coke in the beehive oven are easily coked in modern gas-heated ovens.

Long-flaming and Short-flaming Coals.—The distinction between long-flaming and short-flaming coals is one commonly made by European writers, but it is not often made in this country. A long-flaming coal is simply one having a high percentage of volatile matter, and which gives off a long flame when burned in an ordinary furnace on account of the difficulty of supplying the volatile matter with a sufficient quantity of hot air to cause its complete combustion.

Bituminous Coal contains no Bitumen.—The solvents for bituminous substances, such as bisulphide of carbon and benzole, have no effect upon bituminous coals.

Cannel-coals are bituminous coals that are higher in hydrogen than ordinary coals. They are valuable as “enrichers” in gas-making.

ULTIMATE ANALYSES OF SOME CANNEL-COALS.

| | C. | H. | O + N. | S. | Ash. | COMBUSTIBLE. | | |
|-------------------------|-------|-------|--------|------|-------|--------------|-------|--------|
| | | | | | | C. | H. | O + N. |
| Boghead, Scotland.... | 63.10 | 8.91 | 7.25 | 0.96 | 19.78 | 79.61 | 11.24 | 9.15 |
| Albertite, Nova Scotia. | 82.67 | 9.14 | 8.19 | | | 82.67 | 9.14 | 8.19 |
| Tasmanite, Tasmania.. | 79.34 | 10.41 | 4.93 | 5.32 | | 83.80 | 10.99 | 5.21 |

LIGNITE OR BROWN COAL (HIGH IN OXYGEN).

| | | | | | | | | |
|-----------------------|-------|------|-------|------|------|-------|------|-------|
| Cologne | 63.29 | 4.98 | 26.24 | | 8.49 | 66.97 | 5.27 | 27.76 |
| Bovey, Devonshire.... | 66.31 | 5.63 | 23.43 | 2.36 | 2.36 | 69.53 | 5.90 | 24.57 |
| Trifail, Styria..... | 50.72 | 5.34 | 35.98 | 0.90 | 7.86 | 55.11 | 5.80 | 39.09 |

The above analyses do not give the water or hygroscopic moisture.

Lignite or Brown Coal includes all varieties which are intermediate in properties between peat and coal of the older formations.

It is usually of brownish color, is non-caking, and high in moisture and ash. The best varieties are black and pitchy in lustre and scarcely to be distinguished in appearance from true coals. They contain large proportions of water and of oxygen, and their heating value is therefore much lower than that of the true coals.

Ash.—The composition of ash approximates to that of fire-clay, with the addition of ferric oxide, sulphate of lime, magnesia, potash, and phosphoric acid.

White-ash coals are generally freer from sulphur than the red-ash coals, which contain iron pyrites, but there are exceptions to this rule, as in a coal from Peru which contains more than 10% of sulphur and yields not a small percentage of white ash. In it the sulphur occurs in organic combination, but it is so firmly held that it can only be partially expelled, even by exposure to a very high heating out of contact with the air.

The fusibility of ash varies according to its composition. It is the more infusible the more nearly its composition approaches to fire-clay, or silicate of alumina, and becomes more fusible with the addition of other substances, such as iron, lime, etc. Coals high in sulphur usually give a very fusible ash, on account of the iron with which the sulphur is in combination. A fusible ash tends to form clinker upon the grate-bars, and therefore is objectionable.

Heating Value of Coal.—The heating value of different varieties of coal, together with the relation of the heating value to chemical composition, will be treated at length in the chapter on Heating Value of Coal, but a brief statement of the subject is given below, copied from an article by the author in "Mines and Minerals," October 1898.

The total heating value of coal, measured in British thermal units per pound, is largely a question of geography. It depends on the district in which the coal is mined. It also depends on the percentage of ash in the coal, which varies with individual mines of the district, with parts of the same mine, and with the care taken in mining. With anthracite coals it depends on the size, the larger sizes having the least ash.

Coal is composed of four different things, which may be separated by proximate analysis, viz., fixed carbon, volatile hydrocarbon, ash, and moisture. In making a proximate analysis of a weighed quantity, such as a gram of coal, the moisture is first driven off by heating it to 250° or 300° F., then the volatile matter is driven off by heating it in a closed crucible to a red heat, then the carbon is burned out of the

remaining coke at a white heat, with sufficient air supplied, until nothing is left but the ash.

The fixed carbon has a constant heating value of about 14,600 B.T.U. per lb. The value of the volatile hydrocarbon depends on its composition, and that depends chiefly on the district in which the coal is mined. It may be as high as 21,000 B.T.U. per lb., or about the heating value of marsh-gas, in the best semi-bituminous coals, which contain very small percentages of oxygen, or as low as 10,000 B.T.U. per lb., as in those from some of the Western States, which are high in oxygen. The ash has no heating value, and the moisture has in effect less than none, for its evaporation and the superheating of the steam made from it to the temperature of the chimney-gases absorb some of the heat generated by the combustion of the fixed carbon and volatile matter.

The analysis of a coal may be reported in three different forms, as percentages of the moist coal, of the dry coal, or of the combustible. Thus, suppose one gram of coal is analyzed, and the first heating shows a loss of weight of 0.1 gram, the second of 0.3 gram, the third 0.5 gram, the remainder, or ash, weighing 0.1 gram, the complete report would be as follows:

| | Per cent of the Moist Coal. | Per cent of the Dry Coal. | Per cent of the Combustible. |
|----------------------|--------------------------------|------------------------------|---------------------------------|
| Moisture..... | 10 | | |
| Volatile matter..... | 30 | 33.33 | 37.50 |
| Fixed carbon | 50 | 55.56 | 62.50 |
| Ash..... | 10 | 11.11 | |
| | 100 | 100.00 | 100.00 |

The relation of the volatile matter and of the fixed carbon in the combustible portion of the coal enables us to judge the class to which the coal belongs, as anthracite, semi-anthracite, semi-bituminous, bituminous, or lignite. Coals containing less than 7.5% volatile matter in the combustible would be classed as anthracite, between 7.5 and 12.5 per cent as semi-anthracite, between 12.5 and 25 per cent as semi-bituminous, between 25 and 50 per cent as bituminous, and over 50% as lignitic coals or lignites.

The figures in the second column, representing the percentages in the dry coal, are useful in comparing different lots of coal of one class, and they are better for this purpose than the figures in the first column, for the moisture is a variable constituent, depending to a large extent

PROXIMATE ANALYSES AND HEATING VALUES OF AMERICAN COALS.

| | Moisture. | Volatile Matter. | Fixed Carbon. | Ash. | Sulphur. | Heating Value per lb. Coal, B.T.U. | Volatile Matter, per cent of Combustible. | Fixed Carbon, per cent of Combustible. | Heating Value per lb. Combustible. | Theoretical Evaporation from and at 212° |
|-------------------------------------|-----------|------------------|---------------|-------|----------|------------------------------------|---|--|------------------------------------|--|
| ANTHRACITE: | | | | | | | | | | |
| Northern Coal-field | 3.42 | 4.38 | 83.27 | 8.30 | .73 | 13,160 | 5.00 | 95.00 | 14,900 | 15.42 |
| East Middle Coal-field | 3.71 | 3.08 | 86.40 | 6.22 | .58 | 13,420 | 3.44 | 96.56 | 14,900 | 15.42 |
| West Middle Coal-field | 3.16 | 3.72 | 81.59 | 10.65 | .50 | 12,840 | 4.36 | 95.64 | 14,900 | 15.42 |
| Southern Coal-field | 3.09 | 4.28 | 83.81 | 8.18 | .64 | 13,320 | 4.85 | 95.15 | 14,900 | 15.42 |
| SEMI ANTHRACITE: | | | | | | | | | | |
| Loyalsock Field | 1.30 | 8.10 | 83.31 | 6.33 | 1.63 | 13,930 | 8.86 | 91.14 | 15,500 | 16.05 |
| Bernice Basin | .65 | 9.40 | 83.69 | 5.34 | .91 | 13,400 | 10.98 | 89.02 | 15,500 | 16.05 |
| SEMI-BITUMINOUS: | | | | | | | | | | |
| Broad Top Pa | .79 | 15.61 | 77.30 | 5.40 | .90 | 14,820 | 17.60 | 82.40 | 15,800 | 16.86 |
| Clearfield Co., Pa. | .76 | 22.52 | 71.82 | 3.99 | .91 | 14,950 | 24.60 | 75.40 | 15,700 | 16.25 |
| Gambria Co., Pa. | .94 | 19.20 | 71.12 | 7.04 | 1.70 | 14,450 | 22.71 | 77.29 | 15,700 | 16.25 |
| Somerset Co., Pa. | 1.58 | 16.42 | 71.51 | 8.62 | 1.87 | 14,300 | 20.37 | 79.63 | 15,800 | 16.86 |
| Cumberland, Md. | 1.09 | 17.30 | 73.12 | 7.75 | .74 | 14,400 | 19.79 | 80.21 | 15,800 | 16.86 |
| Pocahontas, Va. | 1.00 | 21.00 | 74.39 | 3.03 | .58 | 15,070 | 22.50 | 77.50 | 15,700 | 16.25 |
| New River, W. Va. | .85 | 17.88 | 77.64 | 3.36 | .27 | 15,220 | 18.95 | 81.05 | 15,800 | 16.86 |
| BITUMINOUS: | | | | | | | | | | |
| Connellsville, Pa. | 1.26 | 30.12 | 59.61 | 8.23 | .78 | 14,050 | 34.03 | 65.97 | 15,300 | 15.84 |
| Younglopheny, Pa. | 1.03 | 36.50 | 59.05 | 2.61 | .81 | 14,450 | 28.73 | 61.27 | 15,000 | 15.53 |
| Pittsburg, Pa. | 1.37 | 35.90 | 32.21 | 5.02 | 1.80 | 13,410 | 41.61 | 58.39 | 14,800 | 15.32 |
| Jefferson Co., Pa. | 1.21 | 32.53 | 60.99 | 4.27 | 1.00 | 14,370 | 35.47 | 64.53 | 15,200 | 15.74 |
| Middle Kittanning Seam, Pa. | 1.81 | 35.33 | 53.70 | 7.18 | 1.98 | 13,200 | 40.27 | 59.73 | 14,500 | 15.01 |
| Upper Freeport Seam, Pa. and Ohio | 1.93 | 35.90 | 50.19 | 9.10 | 2.89 | 13,170 | 43.59 | 56.41 | 14,800 | 15.82 |
| Thacker, W. Va. | 1.38 | 35.04 | 56.03 | 6.37 | 1.28 | 14,090 | 39.32 | 60.67 | 15,300 | 15.74 |
| Jackson Co., Ohio | 3.83 | 32.07 | 57.60 | 6.50 | 1.22 | 12,050 | 35.76 | 64.24 | 14,600 | 15.11 |
| Brier Hill, Ohio | 4.80 | 34.60 | 56.30 | 4.20 | 1.59 | 13,010 | 38.20 | 61.80 | 14,300 | 14.80 |
| Hocking Valley, Ohio. | 6.59 | 34.97 | 48.85 | 8.00 | 1.59 | 12,130 | 42.81 | 57.19 | 14,300 | 14.70 |
| Vanderpool, Ky. | 4.00 | 34.10 | 54.60 | 7.85 | 1.57 | 12,770 | 38.50 | 61.50 | 14,400 | 14.91 |
| Muhlenberg Co., Ky. | 4.33 | 33.65 | 55.50 | 4.50 | 1.57 | 13,060 | 38.86 | 61.14 | 14,400 | 14.91 |
| Scott Co., Tenn. | 1.26 | 35.76 | 53.14 | 8.02 | 1.80 | 13,700 | 34.17 | 65.83 | 15,100 | 15.63 |
| Jefferson Co., Ala. | 1.55 | 34.44 | 59.77 | 2.62 | 1.42 | 13,770 | 37.63 | 63.37 | 14,400 | 14.91 |
| Big Muddy, Ill. | 7.50 | 30.70 | 53.80 | 8.00 | 1.42 | 12,450 | 36.30 | 63.70 | 14,700 | 15.22 |
| Mt. Olive, Ill. | 11.00 | 35.65 | 37.10 | 13.00 | 1.42 | 10,490 | 47.00 | 55.00 | 13,800 | 14.29 |
| Streator, Ill. | 12.00 | 33.30 | 40.70 | 14.00 | 1.42 | 10,580 | 45.00 | 55.00 | 14,300 | 14.80 |
| Missouri | 6.44 | 37.57 | 47.94 | 8.05 | 1.42 | 12,330 | 43.94 | 56.06 | 14,300 | 14.80 |
| LIGNITES AND LIGNITIC COALS: | | | | | | | | | | |
| Iowa | 8.45 | 37.09 | 35.60 | 18.86 | 1.08 | 8,720 | 51.03 | 48.97 | 12,000 | 12.42 |
| Wyoming | 8.19 | 38.72 | 41.83 | 11.36 | 1.08 | 10,390 | 48.07 | 51.93 | 12,900 | 13.35 |
| Utah | 9.29 | 41.97 | 44.37 | 3.30 | 1.68 | 11,630 | 48.00 | 51.40 | 12,000 | 13.04 |
| Oregon Lignite | 15.25 | 42.98 | 33.32 | 7.11 | 1.06 | 8,540 | 54.95 | 45.05 | 11,000 | 11.89 |

on the weather to which the coal has been subjected since it was mined, on the amount of moisture in the atmosphere at the time when it is analyzed, and on the extent to which it may have accidentally been dried during the process of sampling.

The heating value of a coal depends on its percentage of total combustible matter, and on the heating value per pound of that combustible. The latter differs in different districts and bears a relation to the percentage of volatile matter. It is highest in the semi-bituminous coals, being nearly constant at about 15,750 B.T.U. per lb. It is between 14,500 and 15,000 B.T.U. in anthracite, and ranges from 15,500 down to 13,000 or less in the bituminous coals, decreasing usually as we go westward, and as the volatile matter contains an increasing percentage of oxygen.

Table of Heating Values of Coals.—The table of proximate analyses and heating values of American coals on page 46 was compiled by the author for the 1898 edition of the Babcock & Wilcox Co.'s book, "Steam." The analyses are selected from various sources, and in general are averages of many samples. The heating values per pound of combustible are either obtained from direct calorimetric determinations or calculated from ultimate analyses, except those marked (?), which are estimated from the heating values of coals of similar composition. The figures in the last column are obtained by dividing the figures in the preceding column by 965.7, the number of heat-units required to evaporate a pound of water at 212° into steam of the same temperature.

The heating values per pound of combustible given in the table, except those marked (?), are probably within 3% of the average actual heating values of the combustible portion of the coals of the several districts. When the percentage of moisture and ash in any given lot of coal is known the heating value per pound of coal may be found approximately by multiplying the heating value per pound of combustible of the average coal of the district by the difference between 100% and the sum of the percentages of moisture and ash.

In 1892 the author deduced from Mahler's tests on European coals a table of the approximate heating value of coals of different composition, which is given, somewhat modified, below. (Trans. A. S. M. E., vol. xx. p. 337.)

The experiments of Lord and Haas on American coals (Trans. Am. Inst. Mining Engineers, 1897) practically confirm these figures for all coals in which the percentage of fixed carbon is 60% and over of the

APPROXIMATE HEATING VALUE OF COALS.

| Per cent Fixed Carbon in Coal Dry and Free from Ash. | Heating Value per lb. Combustible. | | Per cent Fixed Carbon in Coal Dry and Free from Ash. | Heating Value per lb. Combustible. | |
|--|---------------------------------------|-----------|--|---------------------------------------|-----------|
| | B. T. U. | Calories. | | B. T. U. | Calories. |
| 100 | 14,600 | 8,100 | 68 | 15,480 | 8,600 |
| 97 | 14,940 | 8,300 | 63 | 15,120 | 8,400 |
| 94 | 15,210 | 8,450 | 60 | 14,580 | 8,200 |
| 90 | 15,480 | 8,600 | 57 | 14,040 | 7,900 |
| 87 | 15,660 | 8,700 | 55 | 13,320 | 7,700 |
| 80 | 15,840 | 8,800 | 53 | 12,600 | 7,400 |
| 72 | 15,660 | 8,700 | 51 | 12,240 | 6,900 |

combustible, but for coals containing less than 60% fixed carbon or more than 40% volatile matter in the combustible they are liable to an error in either direction of about 4%. It appears from these experiments that the coal of one seam in a given district, where the ratio of the volatile matter to the total combustible is uniform, has the same heating value per pound of combustible, within one or two per cent, but that coals of the same proximate analysis, and containing over 40% volatile matter, but mined in different districts, may differ 6 or 8 per cent in heating value.

It will be noticed that the coals containing from 72 to 87 per cent of fixed carbon in the combustible have practically the same heating value. This is confirmed by Lord and Haas's tests of Pocahontas coal. A study of these tests and of Mahler's indicates that the heating value of all the semi-bituminous coals, 75 to 87.5 per cent fixed carbon, is within 1½% of 15,750 B.T.U. per lb.

The heating value of any coal may also be calculated from its ultimate analysis, with a probable error not exceeding 2% (except in the cases of cannel-coal and some lignites in which the error may be greater) by the following formula:

$$\text{Heating value per lb.} = 146C + 620\left(H - \frac{O}{8}\right),$$

in which C, H, and O are respectively the percentages of carbon, hydrogen, and oxygen. This formula is known as Dulong's. Its approximate accuracy is proved by both Mahler's and Lord and Haas's experiments, and any deviation of the calorimetric determination of any ordinary coal more than 2% from that calculated by the formula is more likely to proceed from an error in either the calorimetric test or the analysis than from an error in the formula.

Mr. R. S. Hale, in circular No. 5 of the Mutual Boiler Insurance Co., 1898, gives the following table showing the heating value of different coals:

HEATING VALUE OF VARIOUS COALS. COMBUSTIBLE PORTION ONLY CONSIDERED.

| Coal. | Lehigh Anthracite. | Schuykill Anthracite. | Wyoming Anthracite. | Lykens Valley Anthracite. |
|---|--------------------|-----------------------|---------------------|---------------------------|
| Per cent fixed carbon in fuel. | | | | |
| Average of a number of analyses..... | 96.6 | 95.5 | 95 | 91 |
| Relative steam-making value. | | | | |
| Steam Users' Association Circular 3 | 92 | 95 | 97 | 97 |
| Calorific power computed from proximate analyses by Kent's table, B. T. U..... | 14,850 | 15,000 | 15,100 | 15,400 |
| Relative | 94 | 95 | 95.5 | 97 |
| Calorific power computed by Dulong's formula from ultimate analyses, B. T. U..... | 14,255 | | | 15,395 |
| Relative | 92.5 | | | 99.8 |
| Calorific power from another set of analyses, B. T. U..... | 14,755 | | | 15,380 |
| Relative | 95 | | | 100.4 |
| Calorific power Barrus calorimeter, B. T. U.. | | | | |
| Relative | | | | |

| Coal. | Cumberland Semibituminous. | Pocahontas. | New River. | Clearfield. | Nova Scotia. |
|---|----------------------------|-------------|------------|-------------|--------------|
| Per cent fixed carbon in fuel. | | | | | |
| Average of a number of analyses..... | 81 | 78.7 | 76.2 | 76 | 58 |
| Relative steam-making value. | | | | | |
| Steam Users' Association Circular 3..... | 100 | 102 | 95 | 97 | 85 |
| Calorific power computed from proximate analyses by Kent's table, B. T. U..... | 15,840 | 15,840 | 15,780 | 15,780 | 14,150 |
| Relative | 100 | 100 | 99 | 99 | 89 |
| Calorific power computed by Dulong's formula from ultimate analyses, B. T. U..... | 15,400 | 15,552 | 15,623 | | 14,240 |
| Relative | 100 | 101 | 101.5 | | 93 |
| Calorific power from another set of analyses, B. T. U..... | 15,330 | 15,691 | 15,104 | | 14,515 |
| Relative | 100 | 102.4 | 98.6 | | 94.7 |
| Calorific power Barrus calorimeter, B. T. U.. | 14,440 | 14,761 | 14,540 | | 13,068 |
| Relative | 100 | 102.2 | 100.8 | | 90.4 |

The relative values are found by assuming Cumberland 100%.

The figures obtained by the Barrus calorimeter are clearly in error. They are far below those obtained on similar coals by the Mahler calorimeter, and also below the calculated values.

Errors in Reported Heating Values of Coals.—Errors in sampling and in the calorimetric test are quite common, and the error of the latter is almost always in the direction of making the reported heating value of a coal too small. The effect of this error is to make the apparent efficiency of a boiler tested with this coal higher than the real efficiency. Whenever the efficiency reported is high and at the same time the reported heating value of the fuel per pound of combustible is more than 2 per cent lower than the figures in the table on page 46 for coal from the same district, the results should be looked on with suspicion.

Further information on this subject will be found in a paper by the author entitled "The Efficiency of a Steam-boiler: What is it?" in *Trans. Am. Soc. Mechanical Engineers*, vol. xvii. p. 645.

The efficiency commonly obtained in practice in the Western States with bituminous coals burned in ordinary furnaces is not over 60%, and is often less than 50%. Probably 55% is a fair average. The highest efficiency obtainable under the best conditions, with mechanical stokers and with furnaces adapted to burn the volatile matter of the coal, is about 75%. The difference, $20\% \div 75\% = 26\frac{2}{3}\%$, is the margin for saving. If only half of this saving, or $13\frac{1}{3}\%$, can be made, and this is easily possible by the introduction of improved methods of burning Western coals, the reduction of the cost of coal used for steam purposes, were these improvements generally adopted, would amount to many millions of dollars a year. This is the most important improvement that can be made in existing American boiler practice.

Relation of Quality of Coal to the Capacity and Economy of a Boiler.—The actual evaporating capacity of a boiler containing a given amount of heating surface and a given area of grate depends primarily upon the quantity of heat which may be generated in the furnace. This depends on the quantity of coal that may be burned, and also on its quality. The better the quality the greater number of heat-units will be generated by the combustion of each pound. If the coal is high in moisture or in oxygen, not only will the heat-units derived from a pound of it be low, but the attainable temperature will also be lower than that attainable from a better coal; and furnace temperature, as will be shown in another chapter, is an important factor of both capacity and economy.

If the coal is high in ash, not only is its value per ton diminished, but the quantity of ash formed on the grate tends to check the air-supply, and therefore to diminish the rate of combustion, and consequently the quantity of steam generated. If the coal is high in sulphur, the ash will be apt to fuse into clinker, and this may choke the grates completely, necessitating frequent cleaning of the fire.

In order to develop the rated capacity of a boiler with poor coal high in ash, it is necessary to have either a larger grate surface or stronger draft than with good coal. Sometimes strong draft is of no avail, on account of the clinkering of the ash, and in such a case large grate surface is absolutely required.

The quality of coal, therefore, is a most important factor of both the capacity and economy of a boiler. It is possible with a good free-

burning coal to obtain from a given boiler twice as much steam as can be obtained with the same boiler and the same draft from poor coal, and the relative efficiency obtainable with the two coals, or the steam generated per pound of coal, may differ 30 or 40 per cent.

The quality of the coals of the United States varies greatly in different districts. In some limited districts the very best quality is regularly found; in other districts the quality is uniformly from good to medium, and in still others it ranges from poor to worthless.

To buy coal on the reputation of the district in which it is mined is not as good a way as to buy it on a guarantee of quality, as determined by an analysis for water, volatile matter, ash, and sulphur, but it is the most common way. A knowledge of the quality of coals found in different districts is therefore of some importance. The next chapter, "Coal-fields of the United States," is devoted to this subject.

Valuing Coals by Test and by Analysis.—The best way to obtain the relative value of different coals for any particular steam-boiler plant is to have a car-load of each coal tested under the ordinary running conditions of the plant, and then to check the results by a proximate analysis of each. The coal that is most economical for one boiler-plant is not necessarily the most economical for another, on account of the differences in conditions, such as kind of furnace, area of grate surface, draft available, etc. A plant designed for the purpose may be able to use with satisfaction the poorest quality of the fine sizes of anthracite, while another may not be able to use anything cheaper than the best pea coal, and still another, having deficient grate surface, may be compelled to use egg size, or even semi-bituminous.

Besides testing the coals by burning them under the boilers and weighing the quantity of water evaporated, a proximate analysis of each coal should be made so as to arrive at a standard of quality by reference to which future purchases may be made. A schedule of relative values may then be prepared, something like the following:

Anthracite and Semi-anthracite.—The standard is a coal containing 5% volatile matter, not over 2% moisture, and not over 10% ash. A premium of 1% on the price will be given for each per cent of volatile matter above 5% up to and including 15%, and a reduction of 2% on the price will be made for each 1% of moisture and ash above the standard.

Semi-bituminous and Bituminous.—The standard is a semi-bituminous coal containing not over 20% volatile matter, 2% moisture, 6% ash. A reduction of 1% in the price will be made for each 1% of volatile matter in excess of 25%, and of 2% for each 1% of ash and moisture in excess of the standard.

CHAPTER IV.

COAL-FIELDS OF THE UNITED STATES.

THE accompanying maps showing the developed coal-fields of the United States are copied from one that was published in the Reports of the Census of 1890.

The long field extending southwesterly from north-central Pennsylvania to near the centre of Alabama is the great Appalachian field, which contains in a narrow strip on its eastern border the semi-bituminous coals, and west of this strip the best varieties of bituminous gas, steam, and coking coals. East of this field there are several small detached fields, the most important of which are the three anthracite fields of eastern Pennsylvania. To the northwest there is the separate field of Michigan, containing a rather poor quality of bituminous coal. To the west is the Illinois or Central field, extending into Indiana and Kentucky, and containing a great variety of bituminous coals, most of which are inferior to the coals of the Appalachian field. West of the Mississippi the principal field is the great Missouri field covering several States, and having several detached portions reaching into Texas. The coals of this field are mostly of a poor quality. West of the 97th meridian there are a great number of detached fields, mostly of small areas, with every grade of coal from anthracite to lignite. The principal characteristics of the several fields, and the quality of the coal found in each, will be treated of below.

Graphitic Coal in Rhode Island and Massachusetts.—An area of 400 square miles in the central part of Rhode Island and eastern part of Massachusetts, from Newport Neck, R. I., to Mansfield, Mass., contains a variety of anthracite which has been metamorphosed into graphite or graphitic coal. It requires such a high degree of heat for combustion that it can be used only with other combustible material or under a heavy draft. The deposit was worked as early as 1808, at the Portsmouth mine, and at intervals since, but never with profit.

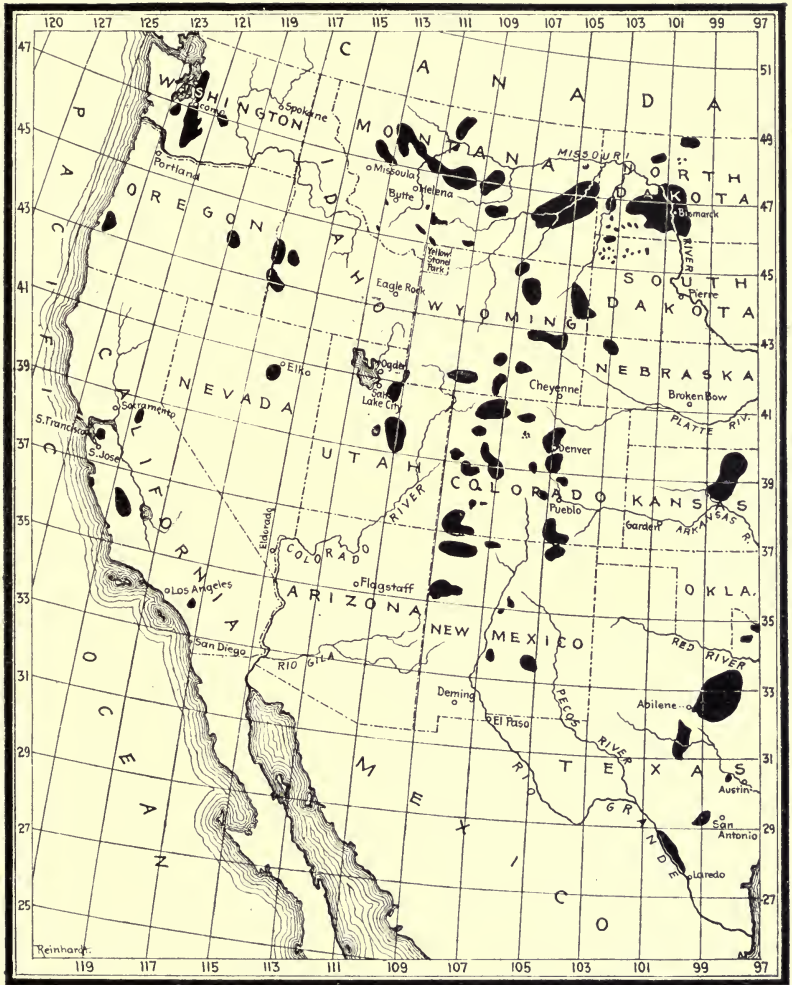

COAL-FIELDS OF THE UNITED STATES WEST OF THE 97TH MERIDIAN.





ANALYSES OF RHODE ISLAND AND MASSACHUSETTS COAL.

| | Water and Volatile Matter. | Fixed Carbon. | Ash. |
|----------------------------|----------------------------|---------------|--------|
| Mansfield, Mass. | 2 to 4 | 90 to 92 | 4 |
| Rhode Island coal. | 7 to 10 | 77 to 84 | 5 to 6 |
| Cranston, R. I. | 8.55 | 3.55 | 82.25 |
| | | | 5.65 |

The Anthracite Coal-beds of Pennsylvania.—These beds are all in the eastern portion of the State. They are three in number, known variously as First, Second, and Third, as Southern, Middle, and Northern, or as Schuylkill, Lehigh, and Wyoming. The area of the first is 138 square miles, of the second 38 square miles, and of the third 196 square miles—a total of 472 square miles. There are fifteen workable beds in this area, of a total thickness of 107 ft. of coal, the thickness of the measures in which the beds are interstratified being about 3000 feet. The coal in all of the fields follows the general law of increasing in percentage of volatile matter and decreasing in hardness towards the western portion of the fields.

In “Mineral Resources” for 1886 the anthracite fields of Pennsylvania are described as grouped into five principal divisions: (1) The southern or Pottsville field, extending from the Lehigh River at Mauch Chunk southwest to within a few miles of the Susquehanna River north of Harrisburg; (2) the western or Mahanoy and Shamokin field, lying between the eastern head-waters of the Little Schuylkill River and the Susquehanna; (3) the eastern middle or the upper Lehigh field, lying between the Lehigh River and Catawissa Creek, principally in Luzerne County; (4) the northern or Wyoming and Lackawanna field, which lies in the two valleys from which its geographical name is derived; (5) the Loyalsock and Mehoopany field, named from the two creeks whose head-waters drain it. The latter is a small field about 20 or 25 miles northwest of the western end of the northern field.

In addition to this geological division the fields are also subdivided under different names and in a different way for trade purposes, the divisions being known as trade regions. These are: (1) The Wyoming region, embracing the entire northern and Loyalsock fields; (2) the Lehigh region, embracing all of the eastern middle field and the Panther Creek district of the southern field; and (3) the Schuylkill region, embracing the western middle field and all of the southern field except the Panther Creek district.

Sizes of Anthracite Coal.—Much confusion and inconvenience in the marketing of anthracite coal has been, in times past, occasioned

by the want of uniformity in the sizes of the coal produced. At a meeting of operators from every part of the anthracite fields, held for the purpose in Wilkesbarre, this subject was considered, and the following sizes of meshes were adopted, to take effect January 1, 1891:

- Egg, through $2\frac{1}{4}$ inches and over 2 inches.
- Stove, through 2 inches and over $1\frac{1}{4}$ inches.
- Chestnut, through $1\frac{1}{4}$ inches and over $\frac{3}{4}$ inch.
- Pea, through $\frac{3}{4}$ inch and over $\frac{1}{2}$ inch.
- Buckwheat, through $\frac{1}{2}$ inch and over $\frac{1}{4}$ inch.
- No. 2 buckwheat, through $\frac{1}{4}$ inch and over $\frac{1}{8}$ inch.

Semi-anthracite in Sullivan Co., Pa.—The Bernice coal-basin lies between Beech Creek on the north and Loyalsock Creek on the south. It is six miles long E. to W., and hardly a third of a mile across. There is 8 ft. of coal in a bed of 12 ft. of coal and slate. The coal of this bed is on the dividing line between anthracite and semi-anthracite, and is similar to the coal of the Lykens Valley district. Nine analyses give a range as follows: Water, 0.65 to 1.97; volatile matter, 3.56 to 9.40; fixed carbon, 82.52 to 89.39; ash, 3.27 to 9.34; sulphur, 0.24 to 1.04.

Progression from Bituminous to Anthracite.—In a direction across the basins northward from Bernice, in Sullivan Co., to Gaines, in Tioga and Potter counties, a distance of 50 miles, is seen the transition from bituminous to anthracite coal, the proportion of volatile matter to fixed carbon in the different basins being:

| | | | Volatile Matter. | Fixed Carbon. |
|------------|------|----------------------|------------------|---------------|
| Gaines, | 1 to | 1.964, equal to..... | 33.7 | 66.3 |
| Blossburg, | 1 " | 3.494, " | 22.3 | 77.7 |
| Barclay, | 1 " | 4.094, " | 19.6 | 80.4 |
| Bernice, | 1 " | 10.289, " | 8.9 | 91.1 |

At Bernice a semi-bituminous coal underlies the semi-anthracite 60 ft., both beds being found in the same hillside only 60 ft. apart.* In another case a coal-bed has two benches, the upper semi-bituminous and the lower anthracite, with 6 ft. of slate bottom. (From reports of 2d Geological Survey of Pennsylvania.)

Early Use of Pennsylvania Anthracite Coal.—Pennsylvania anthracite coal was known as early as 1766, and was used in 1768 in the Wyoming Valley by two blacksmiths named Gore. In 1776 several boat-loads were sent to Carlisle, where it was used during the Revolu-

* It will be noted that this condition in Sullivan Co., Pa., is exactly opposite to that found in western Pennsylvania and central Ohio, where the coals mined over a large extent of country show nearly identical composition. See Lord and Haas's tests in the next chapter.

tionary War to manufacture arms. It was not used for domestic purposes until 1808, when Judge Jesse Fell of Wilkesbarre burned it on an experimental grate of hickory withes. He then made an iron grate, and taught the people in the vicinity how to make such grates. In 1793 the Lehigh Coal Mining Co. was formed, which some years later sold a quantity to the city of Philadelphia for the use of a steam-engine at the water-works, then at Broad and Market streets, but it was not used because it "could not be burned." In 1812 Col. George Shoemaker took nine wagon-loads to Philadelphia, disposed of two or three loads at the cost of handling, and left the rest with different persons for experiment. At the Fairmount Wire and Nail Works the workmen spent a forenoon in fruitless attempts to make a fire with it. At last they closed the furnace doors and went to dinner; returning an hour later, they found the doors red-hot and the furnace all aglow. After that there was no more trouble in burning anthracite. In 1820 the trade was fully established, 365 tons being shipped to Philadelphia in that year.

The failures to burn anthracite in these early days were due to ignorance of the proper conditions for burning it. These are:

1. A very hot fire of wood must first be established.
2. The coal should be laid in a bed several inches deep.
3. The bed of coal must not be poked or otherwise disturbed while beginning to burn.
4. A constant supply of air must be maintained from the grate through the fire.

An interesting account of the early history of the anthracite coal trade will be found in "Mineral Industry" for 1895.

Virginia Anthracite.—In the southwestern part of Virginia occur beds of coal which on analysis prove to be anthracite. They are found in Pulaski and Wythe counties, along the southern border of Little Walker Mountain. The areas are limited and the coals have been greatly disturbed. They do not belong to the true Carboniferous coals, but to the Upper Devonian (Rogers X.) formation, and lie under the true coal-measures of Pennsylvania, Ohio, and northwestern Virginia.

Analyses of seven samples gave:

| Water. | Volatile Matter. | Fixed Carbon. | Ash. |
|--------------|------------------|----------------|--------------|
| 0.35 to 0.80 | 6 to 7.58 | 85.85 to 89.47 | 3.97 to 7.35 |

Anthracite in Colorado.—Anthracite coal of good quality is found in Gunnison Co., Colorado (Hayden's Survey Report for 1874). The

coal is not a true Carboniferous anthracite, but is an "altered lignite" of the Post-Cretaceous formation. The quality varies greatly in different beds and even in the same bed in neighboring localities, occurring in all stages of transition from bituminous to hard anthracite. The following are analyses of some of these coals. No. III might be classified as a semi-bituminous coal, and No. VI as a semi-anthracite.

| | I. | II. | III. | IV. | V. | VI. |
|----------------------|-------|-------|-------|--------|-------|--------|
| Water..... | 2.00 | 1.60 | 4.00 | } 7.40 | 3.68 | } 1.64 |
| Volatile matter | 2.50 | 3.40 | 14.00 | | | |
| Fixed carbon..... | 91.90 | 88.20 | 74.00 | 88.92 | 91.02 | 86.60 |
| Ash..... | 3.60 | 6.80 | 8.00 | 3.68 | 5.30 | 4.37 |

Anthracite in New Mexico.—Dr. R. W. Raymond, formerly U. S. Mining Commissioner, in his report for 1870 describes a bed of true anthracite, 4 to 5 feet thick, near Santa Fé, containing 80.5% of fixed carbon, and another, 1½ miles distant, containing 88% carbon and 5% ash.

BITUMINOUS AND SEMI-BITUMINOUS COAL-FIELDS OF THE UNITED STATES.

The following notes on the bituminous and semi-bituminous coal-fields and on the quality of coal found in them have been compiled from a variety of sources; among others, the reports of the U. S. Census of 1890, the annual volumes of "Mineral Resources of the United States" and "Mineral Industry," reports of the Geological Surveys of Pennsylvania and other States, and various papers in the Transactions of the American Institute of Mining Engineers.

The Triassic Area comprises what is known as the Richmond basin in Chesterfield and Henrico counties, Virginia, and the Deep River and Dan River fields in North Carolina. Charles A. Ashburner, in "Mineral Resources" for 1866, says that the first coal mined systematically in the United States was taken from the Richmond basin, and that in 1822 about 48,214 tons of coal were produced there, more than twelve times the total amount produced in the Pennsylvania anthracite field in the same year. Its maximum output was reached in 1883, when 142,587 tons were mined.

The Bituminous Coals of the Carboniferous Formation (not including the more recent coals of the Western States) are found in four separate fields or basins, which are shown on the map, viz.: 1. The Appalachian field, extending from Pennsylvania to Alabama, containing 59,105 square miles. The eastern portion of the Appalachian

field contains the semi-bituminous coals, which are found in a narrow strip running from northern Pennsylvania through portions of Maryland, Virginia, West Virginia, and Tennessee. 2. The Illinois basin, extending into the western part of Indiana and northwestern Kentucky, 47,188 square miles. 3. The Michigan basin, 6700 square miles. 4. The Missouri or Western basin, 90,343 square miles, covering portions of Iowa, Nebraska, Missouri, Kansas, Indian Territory, and Arkansas, with an extension into Texas. The coal in this basin is in general not so pure as that in the Appalachian field, and contains a great deal of sulphur.

West of the Missouri there are the lignites and lignitic coals (some of them transformed into bituminous and anthracite) of the Rocky Mountain field, containing the coal areas in the States and Territories lying along the Rocky Mountains, and the Pacific Coast field, embracing the coal districts of Washington, Oregon, and California.

The various fields are described at some length in "Mineral Resources" for 1886, and also in the report for 1894. The latter also contains some historical information regarding the development of these fields. "Mineral Resources" for 1892 contains some interesting contributions from State geologists on the coal-fields of several States.

Pennsylvania.—The Appalachian coal-field extends over portions of 31 counties. It has a total area of 12,302 square miles in the State.

Blossburg field, Tioga Co. Five beds, A, B, C, D, and E, from $2\frac{1}{2}$ to $5\frac{1}{2}$ feet thick. Coal A is the lowest of the series. Coal B, Bloss bed, $4\frac{1}{2}$ to $5\frac{1}{2}$ feet, is the best. Coal C is a sort of cannel-coal of an inferior grade in this location; farther west it improves.

McIntyre basin, Lycoming Co. The coal-beds are similar to those of the Blossburg region, three of them, E, C, and A, being of workable thickness.

Towanda basin, Bradford Co. One seam also found in the McIntyre basin.

Snowshoe basin, Centre Co. Eight miles in length by four in width. Five seams, A, B, C, D, E. A has 6 to $3\frac{1}{2}$ feet, and E 5 feet, of good coal.

Clearfield region, on Moshannon Creek, in Clearfield Co. Three workable seams, 5, $4\frac{1}{2}$, and 4 feet. The latter, coal D, is principally worked.

Johnstown region, Cambria Co. Five beds, A, B, C, D, E, $2\frac{1}{2}$ to 7

feet thick. The coal is mostly used in the iron- and steel-works in the vicinity.

Broad Top basin, in Bedford, Huntington, and Fulton counties, 40 miles east of the Alleghany Mountains. The area is 81 square miles. Five workable beds, the principal one being 5 to 10 feet thick.

Salisbury basin, Somerset Co. A short extension of the Cumberland coal-field of Maryland. It contains all the coals of the Lower measures and several square miles of the Pittsburg seam.

Semi-bituminous coal is produced in all the above-named fields.

Main Field of Western Pennsylvania. One large field in the southwestern counties. The several beds are found in different series, known respectively as the Upper Barren, the Upper Productive, the Lower Barren, and the Lower Productive coal-measures, and the Conglomerate series.

The Upper Barren measures contain but one seam of commercial importance, the Washington seam, which attains its best development, 3 to 3½ feet, in Washington and Fayette counties.

The Upper Productive Coal-measures contain the great Pittsburg seam, 6 to 12 feet thick, in Fayette, Washington, Allegheny, Westmoreland, and Greene counties, smaller areas also occurring in Indiana, Somerset, and Beaver counties. The famous Connellsville coke is made from this seam. The Connellsville region is a narrow strip, about 3 miles wide and 60 miles in length. The Pittsburg seam here affords from 7 to 8 feet of coal. The quality of the coal is intermediate between the semi-bituminous, lying to the east of it, and the fat bituminous coals, to the north and west. The Waynesburg bed, an important seam in Greene, Washington, Fayette, and Westmoreland counties; the Uniontown, in Fayette and Greene counties; the Sewickley and Redstone beds, in Westmoreland and Allegheny counties, are also in the Upper Productive measures.

The Lower Barren measures contain several workable beds of limited area in Indiana, Somerset, Butler, Armstrong, and Beaver counties.

The Lower Productive measures contain the Freeport Lower coal, a bed of great importance in Jefferson, Indiana, Clearfield, Cambria, Armstrong, Centre, and Allegheny counties, and workable in parts of Beaver, Butler, Elk, Blair, Cameron, Westmoreland, and Fayette counties; the Freeport Upper coal, workable in fifteen counties; the Kittanning Upper, or Darlington, bed, consisting partly of cannel and partly of bituminous coal, of workable thickness in parts of Butler,

Armstrong, Somerset, Beaver (cannel), Indiana, Jefferson, Elk, and Lycoming counties; the Kittanning Middle, locally workable in Butler, Lawrence, Jefferson, Armstrong, Elk, Cameron, and Clarion counties; the Kittanning Lower, workable in twenty-two counties, an excellent coking coal along the Alleghany escarpment, and in the western counties often a good gas-coal; the Millerstown bed, locally workable in Butler County; the Clarion bed, in some of the western counties, usually quite thin; and the Brookville bed "A" of the Alleghany escarpment counties, often a very sulphurous coal.

The Conglomerate series contains the Mercer Upper and Lower coals, workable over limited areas in Lawrence, Jefferson, McKean, Elk, Mercer, and Venango counties; the Quakertown coal, workable over a small area in Mercer County; and the Sharon coal, good but nearly exhausted in Mercer County, and thin and inferior in Warren and Crawford counties.

Analyses of Pennsylvania Bituminous and Semi-bituminous Coals.

—The analyses given in the two following tables are selected from reports of the Pennsylvania Geological Survey and from various papers in the Transactions of the American Institute of Mining Engineers. The figures of approximate heating value per lb. of combustible are interpolated from the table on p. 48 showing the relation of heating value to the percentage of volatile matter in the combustible. For

PENNSYLVANIA SEMI-BITUMINOUS COALS.

| County. | No. of Samples. | Water. | Volatile Matter. | Fixed Carbon. | Sulphur. | Ash. | Volatile Matter per cent of Combustible. | Approx. Heating Value per lb. Combustible. |
|-------------------|-----------------|--------|------------------|---------------|----------|-------|--|--|
| Bradford | 7 | 0.82 | 16.95 | 69.26 | 0.67 | 12.29 | 19.7 | 15,800 |
| Sullivan..... | 12 | 3.24 | 13.03 | 72.74 | 0.61 | 10.38 | 15.2 | 15,700 |
| Tioga..... | 17 | 1.65 | 20.50 | 67.79 | 1.26 | 8.85 | 23.2 | 15,750 |
| Lycoming..... | 2 | 1.06 | 17.53 | 72.42 | 0.84 | 8.15 | 19.6 | 15,800 |
| Centre..... | 1 | 0.60 | 22.60 | 68.71 | 2.69 | 5.40 | 24.7 | 15,700 |
| Huntingdon..... | 8 | 0.47 | 16.54 | 72.85 | 1.98 | 8.16 | 18.5 | 15,800 |
| "..... | 5 | 0.79 | 13.84 | 78.46 | 0.91 | 6.00 | 15.0 | 15,700 |
| "..... | 8 | 0.78 | 17.38 | 76.14 | 0.88 | 4.81 | 18.6 | 15,800 |
| Blair * | 9 | 1.06 | 27.27 | 60.69 | 2.31 | 8.66 | 31.0 | 15,550 |
| Cambria: | | | | | | | | |
| Lower bed, B..... | 7 | 0.74 | 21.21 | 68.94 | 1.98 | 7.51 | 23.5 | 15,750 |
| Upper bed, C..... | 1 | 1.14 | 17.18 | 73.42 | 1.41 | 6.58 | 19.0 | 15,800 |
| Clearfield: | | | | | | | | |
| Upper bed, C..... | 9 | 0.70 | 23.94 | 69.28 | 1.42 | 4.62 | 25.7 | 15,700 |
| Lower bed, D..... | 8 | 0.81 | 21.10 | 74.08 | 0.42 | 3.36 | 22.2 | 15,800 |
| Somerset | 30 | 1.15 | 19.77 | 67.78 | 1.61 | 9.67 | 22.6 | 15,800 |

* According to these analyses the Blair Co. coals should not be included in the semi-bituminous class. They are much higher in volatile matter than the semi-bituminous coals of Cambria Co., which is west of Blair Co.

the semi-bituminous coals they are probably within 2% of being accurate; for the bituminous coals within 4%.

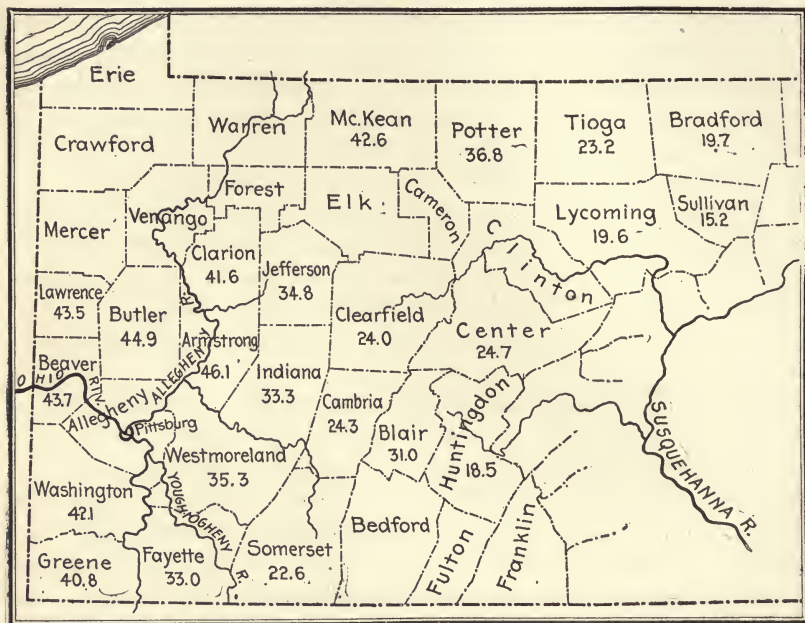

FIG. 2.—SEMI-BITUMINOUS AND BITUMINOUS COAL REGION OF PENNSYLVANIA.

(The figures under the names of the counties represent the percentage of volatile matter of the coals of each county, as given in the table of analyses.)

The figures of volatile matter per cent of combustible are entered on the accompanying map under the names of the several counties. It will be seen that there is a general tendency for the volatile matter to increase towards the west and north. Blair County seems to be an exception. The boundary line along which the semi-bituminous coals grade, more or less rapidly, into the bituminous, and the location of beds of bituminous coals within the limits of the portion of the field which contains the semi-bituminous coals, as far as the author is aware, have not yet been laid down on any map.

The difference between the semi-bituminous and the bituminous coals of Pennsylvania is an important one economically. The former have on the average a heating value per pound of combustible about 6 per cent higher than the latter, and they also burn with much less smoke in ordinary furnaces.

PENNSYLVANIA BITUMINOUS COALS.

| County. | Number of Samples. | Water. | Volatile Matter. | Fixed Carbon. | Sulphur. | Ash. | Vol. Matter, per cent of Combustible. | Approx. Heating Value, per cent of Combustible. |
|--------------------------|--------------------|--------|------------------|---------------|----------|-------|---------------------------------------|---|
| Jefferson..... | 26 | 1.21 | 32.53 | 60.99 | 1.00 | 3.76 | 34.8 | 15,300 |
| Indiana..... | 29 | 0.98 | 29.26 | 58.74 | 1.73 | 9.46 | 33.3 | 15,400 |
| Westmoreland..... | 27 | 1.14 | 32.27 | 59.23 | 1.50 | 5.97 | 35.3 | 15,200 |
| Fayette..... | 12 | 0.95 | 29.75 | 60.47 | 1.79 | 7.04 | 33.0 | 15,400 |
| Potter..... | 3 | 1.72 | 32.28 | 55.32 | 1.01 | 9.67 | 36.8 | 15,100 |
| McKean..... | 11 | 2.25 | 34.49 | 46.25 | 2.97 | 14.02 | 42.6 | 14,600 |
| Clarion..... | 7 | 1.97 | 38.60 | 54.15 | 1.19 | 4.10 | 41.6 | 14,700 |
| Armstrong..... | 1 | 1.18 | 42.55 | 49.69 | 2.00 | 4.58 | 46.1 | 14,000 |
| Butler..... | 11 | 1.91 | 39.88 | 48.97 | 1.97 | 7.22 | 44.9 | 14,200 |
| Lawrence..... | 14 | 2.11 | 40.45 | 52.51 | 1.37 | 3.25 | 43.5 | 14,500 |
| Beaver..... | 20 | 1.96 | 39.04 | 50.20 | 2.00 | 6.96 | 43.7 | 14,500 |
| Washington..... | 21 | 1.16 | 37.11 | 50.99 | 2.06 | 8.72 | 42.1 | 14,700 |
| Greene..... | 17 | 1.14 | 35.74 | 51.75 | 1.79 | 9.10 | 40.8 | 14,800 |
| Youghiogheny River*..... | | 1.03 | 36.49 | 59.05 | 0.81 | 2.61 | 37.9 | 15,100 |
| Connellsville †..... | | 1.26 | 30.10 | 59.61 | 0.78 | 8.23 | 33.5 | 15,400 |

The following tables show the great similarity in composition in the coals of the upper and lower coal-measures in the same geographical belt or basin. They also show the tendency of the volatile matter to increase to the westward:

ANALYSES FROM THE UPPER COAL-MEASURES (PENNA.) IN A WESTWARD ORDER.

| Localities. | Moisture. | Vol. Mat. | Fixed Carb. | Ash. | Sulphur. |
|------------------------|-----------|-----------|-------------|------|----------|
| Anthracite..... | 1.35 | 3.45 | 89.06 | 5.81 | 0.30 |
| Cumberland, Md..... | 0.89 | 15.52 | 74.28 | 9.29 | 0.71 |
| Salisbury, Pa..... | 1.66 | 22.35 | 68.77 | 5.96 | 1.24 |
| Connellsville, Pa..... | | 31.38 | 60.30 | 7.24 | 1.09 |
| Greensburg, Pa..... | 1.02 | 33.50 | 61.34 | 3.23 | 0.86 |
| Irwin's, Pa..... | 1.41 | 37.66 | 54.44 | 5.86 | 0.64 |

ANALYSES FROM THE LOWER COAL-MEASURES IN A WESTWARD ORDER.

| Localities. | Moisture. | Vol. Mat. | Fixed Carb. | Ash. | Sulphur |
|-------------------|-----------|-----------|-------------|------|---------|
| Anthracite..... | 1.35 | 3.45 | 89.06 | 5.81 | 0.30 |
| Broad Top..... | 0.77 | 18.18 | 73.34 | 6.69 | 1.02 |
| Bennington..... | 1.40 | 27.23 | 61.84 | 6.93 | 2.60 |
| Johnstown..... | 1.18 | 16.54 | 74.46 | 5.96 | 1.86 |
| Blairsville..... | 0.92 | 24.36 | 62.22 | 7.69 | 4.92 |
| Armstrong Co..... | 0.96 | 38.20 | 52.03 | 5.14 | 3.66 |

* The Youghiogheny River is in Allegheny, Westmoreland, and Fayette counties. The coal mined along this river is a favorite coal in the Ohio and Mississippi river markets.

† Connellsville is in Fayette County. The coal of this region is chiefly used for making coke for blast-furnace and foundry purposes.

Maryland Semi-bituminous Coal.—The Cumberland coal-field, in Allegany Co., Md., is 30 miles long and of an average breadth of $4\frac{1}{2}$ miles. Its northern end reaches into Pennsylvania and its southern extremity into West Virginia. The main bed is from 12 to 14 ft. thick. The coal is one of the best steam-coals mined in the United States. It is jet black and glossy; is friable, and becomes pulverized in transportation and handling. There are several other beds from 2 to 6 ft. in thickness, the whole series of the Pennsylvania coal-measures being found in the district.

*Elk Garden and Upper Potomac Coal-fields.**

On the extreme fringe of the great Appalachian coal-basin is a long, narrow, detached coal-field, which is, in some respects, one of the most important in the United States. This field, about 90 miles long by $2\frac{1}{2}$ to 16 miles wide, extends from the southwest corner of Somerset County, Pa., through Allegany and Garrett counties, Md., Mineral, Grant, and Tucker counties, W. Va., into Randolph County, W. Va. In this distance four distinct subdistricts are recognized, the Wellersburg in Pennsylvania, the Cumberland-Georges Creek in Maryland, and the Elk Garden and the Upper Potomac in West Virginia. It is the nearest to tide-water of all the bituminous coal-fields which supply the great coal markets of the northern Atlantic seaboard, and its coal-beds are so situated as to permit a well-nigh unlimited increase of production should the trade of these markets demand it.

This great coal-field has sometimes been termed the Cumberland coal-field, but the name is now more appropriately applied to a coal (that of the Big Vein) which is not mined throughout the entire district. As the district is watered chiefly by the Potomac River and its tributaries, and as most of the mining is along the banks of that stream, the name "Potomac Basin" has been suggested for this entire coal-field; the distinctive and well-known names of the several subbasins, however, being still retained.

The general course of this basin is northeast and southwest. It is hemmed in by the Alleghany Front Mountains on the east and the Backbone Mountains on the west. Its general shape from Pennsylvania to near the southern border of Tucker County, W. Va., is that of a wedge, very narrow in Pennsylvania, only $2\frac{1}{2}$ miles wide at the State

* Abstract from a paper by Joseph D. Weeks, read before the American Institute of Mining Engineers, 1894.

line, and widening as the mountains draw away from each other, until, at the point named in Tucker County, it is some 16 miles wide.

The northern end of this field passes through the western part of Allegany County and a portion of the eastern part of Garrett County, Maryland, and from it the entire coal product of Maryland is obtained.

Virginia.—There are several detached coal-fields in the Mesozoic rocks east of the Alleghany Mountains. They are described by O. J. Heinrich, in *Trans. A. I. M. E.*, 1878, vol. vi. The Richmond basin, 189 square miles, chiefly in Powhatan and Chesterfield counties, west of Richmond, is the most important. It contains two workable beds, the lower 3 to 5 ft. thick, and the upper 20 to 40 ft. thick. The coal is chiefly bituminous, containing 30% or upwards of volatile matter in the combustible, but at Carbon Hill semi-bituminous is found, also “carbomite” or natural coke, corresponding in analysis to semi-anthracite.

The Appalachian semi-bituminous coals are found in the southwestern portion of the State, in Tazewell County, on the West Virginia border, and the bituminous coals in the southwestern corner of the State near the Kentucky line.

The Pocahontas coal-field embraces parts of Buchanan, Dickinson, Lee, Russell, Scott, Tazewell, and Wise counties, at the southern edge of the Flat Top region, including the Clinch valley field, containing the Lower Productive measures of the Appalachian field.

The Pocahontas Flat Top coal-measures are above the water-level, in seams ranging from 5 to 13 ft. in thickness, extending through an area estimated to contain not less than 300 sq. miles. Pocahontas semi-bituminous coal is from the Lower coal-measures and contains from 18 to 20 per cent of volatile matter. It is mined in Tazewell County, Virginia, and in Mercer and McDowell counties, West Virginia, the adjoining counties to the north. The veins dip to the north and west, and the extension of the Ohio division of the Norfolk and Western Railroad north to the Ohio River and the road west to the Cumberland Mountains pass through the Middle and Upper measures, thus opening up coal of greater volatile matter, bituminous, splint and cannel.

The development of this now famous region began in 1881, but not until 1883 was any coal shipped out of the country. In the latter year the Norfolk and Western Railroad completed its New River extension, and then began the industry which to-day makes the Flat Top field a prominent factor in the coal production of the United States.

North Carolina.—Semi-anthracite is found in two unimportant beds, 18 ins. thick, in the Dan River field, 40 miles long, 4 to 7 miles wide, of which 8 miles are in Virginia. The Deep River field, 30 miles long by 3 wide, contains five beds, all differing in character, ranging from bituminous coal to an impure plumbago, as shown by the following analyses:

| | Volatile Matter. | Fixed Carbon. | Ash. |
|-----------------------------------|------------------|---------------|------|
| Bituminous, 3 ft. thick..... | 32.8 | 63.8 | 4 |
| Semi-bituminous, 1 ft. thick..... | 23.6 | 72.6 | 4 |
| Anthracite, 3 ft. thick..... | 6.6 | 83.8 | 9.6 |
| Plumbagin slate, 2 ft. thick..... | | 10.4 | 78 |
| Plumbago, 4 ft. thick..... | | 18.2 | 74 |

West Virginia.—Out of 54 counties only 6 are destitute of coal. The quality is semi-bituminous in the eastern portion of the coal-bearing district and bituminous in the western. The first coal-field is the Potomac basin, an extension of the Cumberland semi-bituminous coal-field of Maryland. The Monongahela basin embraces five beds, of which the Pittsburg, 9½ ft. of clear coal, is the most important. This is a gas-coal, and makes a hard coke, but is high in sulphur. The New River coal-field lies in Fayette and Raleigh counties, bordering the New River from 40 miles from Quinnimont to Kanawha Falls. It contains both semi-bituminous and bituminous steam, coking and gas-coals of excellent quality. The Kanawha coal-field lies along the Kanawha River and its branches, below the junction of the New and Gauley rivers. The coal is bituminous, and includes gas-coals, cannel and hard splint coal. It is largely mined for shipment down the Ohio River.

WEST VIRGINIA ANALYSES, FROM PRIME'S REPORT OF THE CENTENNIAL EXHIBIT.

| | Moisture. | Volatile Matter. | Fixed Carbon. | Sulphur. | Ash. |
|---------------------------------------|-----------|------------------|---------------|----------|-------|
| Piedmont, Mineral Co..... | 0.82 | 19.36 | 75.86 | 0.71 | 3.96 |
| Austen, Preston Co..... | 0.11 | 31.12 | 66.29 | 0.64 | 2.48 |
| Kingwood, top of bed..... | 0.34 | 31.47 | 65.66 | 0.58 | 2.53 |
| Monongahela Co., Upper Freeport bed.. | 0.63 | 28.06 | 54.28 | 0.77 | 17.03 |
| “ “ Pittsburg bed..... | 0.39 | 38.64 | 54.77 | 2.54 | 6.20 |
| “ “ Redstone seam..... | 0.37 | 37.88 | 54.36 | 2.87 | 7.39 |
| “ “ Sewickley seam..... | 0.44 | 35.78 | 54.31 | 3.10 | 9.47 |
| “ “ Waynesburg seam... .. | 0.74 | 35.36 | 56.35 | 0.71 | 7.55 |
| Despard, Harrison Co..... | | 40.00 | 53.30 | ... | 6.70 |
| Murphy's Run, Harrison Co..... | 1.58 | 37.10 | 49.08 | 2.84 | 9.40 |
| Wood's Run, Ohio Co..... | 1.74 | 42.97 | 50.99 | 2.88 | 4.30 |
| Hartford, Putnam Co..... | 3.43 | 44.38 | 46.88 | 1.57 | 5.30 |
| Osborn, Wayne Co..... | 2.30 | 40.43 | 48.72 | 0.76 | 8.55 |

CANNEL-COAL.

| | | | | |
|------------------------------------|-------|-------|------|-------|
| Falling Rock Creek, Elk River..... | 43.20 | 50.80 | | 6.00 |
| Peytona, Boone Co..... | 46.00 | 41.00 | | 13.00 |

ANALYSIS OF WEST VIRGINIA COALS, NEW RIVER REGION.

| | Moisture. | Volatile Matter. | Fixed Carbon. | Sulphur. | Ash. |
|------------------------|-----------|------------------|---------------|----------|------|
| Quinnimont lump..... | 0.76 | 18.65 | 79.26 | 0.23 | 1.11 |
| “ slack..... | 0.83 | 17.57 | 79.40 | 0.28 | 1.92 |
| Fire Creek..... | 0.61 | 22.34 | 75.02 | 0.56 | 1.47 |
| Longdale (Sewell)..... | 1.03 | 21.88 | 72.32 | 0.27 | 5.27 |
| Nuttalburg..... | 1.35 | 25.35 | 70.67 | 0.57 | 2.10 |
| Hawk's Nest..... | 0.93 | 21.83 | 75.37 | 0.26 | 1.87 |
| Ansted..... | 1.40 | 32.61 | 63.10 | 0.74 | 2.15 |

Eastern Kentucky.—The Appalachian field extends into Eastern Kentucky, including fifteen counties and portions of five others, covering altogether 8983 square miles. The following analyses are from Owen's Geological Survey of the State:

| No. of Bed. | Locality. | Moisture. | Volatile Matter. | Fixed Carbon. | Ash. | Sulphur. |
|-------------|----------------------------|-----------|------------------|---------------|-------|----------|
| 1. | Lawrence County..... | 3.50 | 36.30 | 57.30 | 2.90 | 1.15 |
| 2. | Carter County..... | 4.10 | 34.60 | 55.25 | 4.77 | 1.41 |
| 3. | Greenup County..... | 3.56 | 35.00 | 52.34 | 9.02 | 2.59 |
| 4. | Carter County (cannel).... | 0.60 | 66.30 | 28.30 | 4.80 | 1.32 |
| 5. | Lawrence County..... | 3.20 | 32.30 | 53.00 | 11.50 | 1.20 |
| 6. | Boyd County..... | 3.27 | 33.77 | 54.51 | 8.91 | 1.56 |
| 7. | Coalton County..... | 5.19 | 32.04 | 55.59 | 6.71 | 1.68 |

The following analyses of Eastern Kentucky coals are taken from a report by Capt. H. S. Hodges, Corps of Engineers U. S. A., January, 1900,* on a Survey of the Big Sandy River, West Virginia and Kentucky, including Levisa and Tug Forks:

| | No. of Analyses. | Moisture. | Volatile Matter. | Fixed Carbon. | Ash. | Sulphur. | Vol. Mat. % of Combustible. |
|-------------------------|------------------|-----------|------------------|---------------|-------|----------|-----------------------------|
| LAWRENCE COUNTY: | | | | | | | |
| Peach Orchard coal | 2 | 4.60 | 35.70 | 53.28 | 6.42 | 1.08 | 40.1 |
| McHenry coal..... | 1 | { 3.24 | 36.56 | 54.95 | 5.24 | 1.19 | 40.0 |
| | | { 3.36 | 37.05 | 52.82 | 5.55 | 1.22 | 41.2 |
| JOHNSON COUNTY: | | | | | | | |
| Bituminous coals.. | 5 | { 2.66 | 38.04 | 56.30 | 3.00 | 1.29 | 40.3 |
| | | { 1.20 | 41.80 | 46.00 | 11.00 | 0.96 | 47.6 |
| Cannel coals..... | 8 | { 1.80 | 49.20 | 44.00 | 5.00 | 0.85 | 52.8 |
| | | { 1.20 | 64.39 | 26.36 | 8.05 | 1.67 | 71.0 |
| FLOYD COUNTY: | | | | | | | |
| | 9 | { 3.80 | 33.80 | 60.60 | 1.80 | 0.48 | 35.8 |
| | | { 1.30 | 36.70 | 51.70 | 10.30 | 1.36 | 41.5 |
| PIKE COUNTY: | | | | | | | |
| | 37 | { 1.80 | 26.80 | 67.60 | 3.80 | 0.97 | 28.4 |
| | | { 1.60 | 41.00 | 50.37 | 7.00 | 0.03 | 42.9 |
| Average of 37 | | | 34.77 | 58.61 | | | 37.2 |
| Cannel coal..... | 1 | 0.58 | 54.07 | 40.64 | 4.70 | 0.87 | 57.1 |
| MARTIN COUNTY: | | | | | | | |
| | 3 | { 1.46 | 32.60 | 62.68 | 3.26 | | 34.2 |
| | | { 2.47 | 34.18 | 55.03 | 8.32 | 1.17 | 38.3 |

* H. R. Document No. 326, 56th Congress, 1st Session.

The analyses here given are selected from those in the original report, to show the range of quality, as indicated by the percentage of volatile matter in the combustible, of the coals of the several counties.

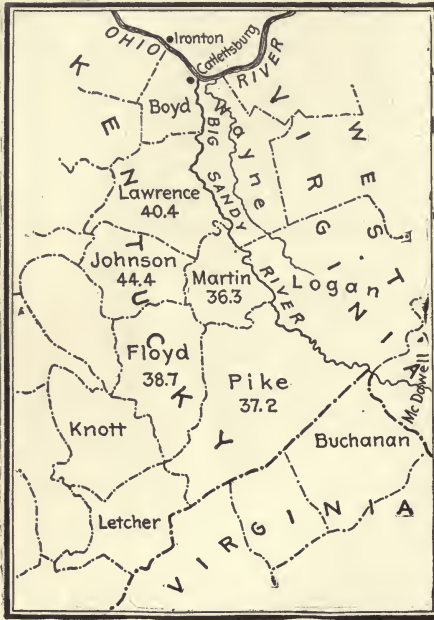

FIG. 3.—BIG SANDY COAL REGION OF EASTERN KENTUCKY.

The relative location of the counties, and the percentage of volatile matter per pound of combustible in the bituminous (not cannel) coal in each county, as given in the table, are shown in the accompanying map.

The author commends to State geologists and others who have occasion to make reports on the extent and quality of coal deposits the method of mapping both the location and the quality which is shown here and also on pages 60 and 72. The reports of the U. S. Geological Survey, of the U. S. Census, and of the Geological Surveys of the several States would be of greater value than they now are if they contained such maps.

Tennessee.—The Appalachian field crosses the eastern part of Tennessee in a comparatively narrow belt, 71 miles wide at the northern boundary and narrowing to 50 miles at the southern or Alabama and Georgia State line. The workable coal-area is confined to what is known as the Cumberland table-land. About 5100 square miles are contained in the area, which is embraced in nineteen counties. There are nine seams, of which six are over 3 ft. in thickness. The coals range from semi-bituminous to bituminous, and some are of excellent quality. In Campbell County is a part of the famous Jellico steam-coal field. The Sewanee vein is one of the most important ones in the State and is worked extensively in Grundy County. Coke of high grade is made from the coal of this seam. A comprehensive paper on the Tennessee coal-fields, by Prof. J. M. Safford, was published in "Mineral Resources," 1892.

ANALYSES OF TENNESSEE COALS.

| | Moisture and Volatile Matter. | Fixed Carbon. | Ash. |
|--|----------------------------------|------------------|------|
| Addison's Creek, Cumberland Mountains. | 9.00 | 83.22 | 7.78 |
| Crow Creek..... | 14.00 | 77.70 | 8.30 |
| Sewanee Mining Co..... | 14.21 | 79.56 | 6.25 |
| Tracy City..... | 29.00 | 65.50 | 5.50 |
| Marion, Upper Seam..... | 38.00 | 59.50 | 2.50 |
| Etna..... | 21.39 | 74.20 | 4.41 |
| Chattanooga..... | 26.80 | 63.90 | 9.30 |
| Coal Creek, Anderson..... | 40.00 | 55.00 | 5.00 |

Georgia.—The Appalachian coal-field enters the extreme northwest corner of the State, the coal-measures occupying an area of from 150 to 170 sq. miles. The coal is similar in quality to that of Tennessee. One analysis, from Dade Co., gave: Moisture, 1.20; volatile matter, 23.05; fixed carbon, 60.50; ash, 15.16; sulphur, 0.84.

Alabama.—The southern extremity of the Appalachian coal-field covers about 5500 sq. miles, in the northern part of the State. There are three separate basins: the Warrior, 5000 sq. miles, extending nearly across the State; the Cahaba, 180 to 200 sq. miles, to the southwest of the Warrior field, and the Coosa, 150 sq. miles, east of the Cahaba and on the northwest side of the Coosa River. The coal-measures contain ten or twelve beds of workable thickness. The Cahaba Basin coals are the best in the State. The larger bed is 12 ft. thick, of good coal.

The following analyses are from the reports of E. A. Smith, State geologist:

| Bed. | County. | Moisture. | Volatile Matter. | Fixed Carbon. | Ash. | Sulphur. |
|-----------------------|-------------------|-----------|---------------------|------------------|-------|----------|
| Cahaba Basin: | | | | | | |
| Cahaba..... | Shelly..... | 1.66 | 33.28 | 63.04 | 2.02 | .53 |
| McGinnis..... | | 1.91 | 32.65 | 63.91 | 1.53 | .63 |
| Moyle..... | | 1.93 | 32.84 | 59.64 | 5.59 | 3.78 |
| Little Pittsburg.. | | 2.05 | 33.47 | 62.20 | 2.28 | .64 |
| Conglomerate... | | 2.13 | 30.86 | 64.54 | 2.47 | 1.48 |
| Helena..... | | 2.54 | 29.44 | 66.81 | 1.21 | .53 |
| Montevallo..... | | 2.13 | 27.03 | 66.22 | 4.62 | .50 |
| Warrior Basin: | | | | | | |
| Townley..... | Walker..... | 3.01 | 29.08 | 63.35 | 4.56 | .71 |
| Jagger..... | "..... | 3.09 | 29.04 | 56.54 | 11.33 | .57 |
| Burnett's..... | Marion..... | 3.69 | 35.38 | 58.52 | 2.41 | 1.73 |
| Pratt Co.'s..... | Upper Jefferson.. | 1.47 | 32.29 | 59.50 | 6.73 | 1.22 |
| "..... | Lower " .. | 1.53 | 30.68 | 63.69 | 4.10 | .61 |

Ohio.—The Appalachian coal-field in Ohio covers more than 10,000 square miles in the eastern and southeastern portion of the State, its length being about 180 miles and its width about 80 miles. The coals are all of the bituminous variety, are known in general terms as block coal, gas-coal, cannel-coal, etc., and by many special names, as Mahoning Valley, Hocking Valley, Salineville, etc., accord-

ing to the producing localities. Thirteen workable beds are found along the Ohio River, but only two of them, No. 6, or the "Great Vein" of Perry Co., and No. 8, or the Pittsburg bed, are found workable over great areas. No. 1, the "block coal" of the Mahoning Valley, called elsewhere "Massillon" and "Jackson" coal, is of great excellence wherever found. It is thinly laminated, and is broken by transverse cleavages into cubical blocks, whence its name of "block coal."

ANALYSES OF OHIO COALS FROM DIFFERENT BEDS (NEWBERRY).

| Coal, No. | Locality. | Moisture. | Vol. Mat. | Fixed Carb. | Ash. | Sulphur. |
|-----------|-----------------------|-----------|-----------|-------------|-------|----------|
| I. | Mahoning Co..... | 2.47 | 31.83 | 64.25 | 1.45 | 0.56 |
| II. | Holmes Co... .. | 2.15 | 28.65 | 52.70 | 16.50 | 2.13 |
| III. | " | 3.90 | 40.50 | 49.95 | 5.65 | 1.55 |
| III. | Yellow Creek | 2.50 | 36.60 | 56.30 | 4.60 | 2.05 |
| IV. | Coshocton Co.(Cannel) | 1.50 | 44.40 | 44.50 | 9.60 | 1.72 |
| IV. | Stark Co..... | 7.00 | 30.80 | 59.50 | 2.70 | 0.65 |
| V. | Columbiana Co..... | 1.15 | 40.45 | 53.75 | 4.65 | 3.51 |
| VI. | " | 1.60 | 29.29 | 64.50 | 4.00 | 2.80 |
| VI. | Muskingum Co..... | 3.47 | 37.88 | 53.30 | 5.35 | 2.24 |
| VI. | Jefferson Co..... | 1.40 | 30.90 | 65.90 | 1.80 | 0.98 |
| VII. | Saline Co..... | 1.70 | 34.30 | 59.50 | 4.50 | 1.63 |
| VII. | Carroll Co..... | 2.80 | 30.20 | 64.10 | 2.90 | 1.23 |
| VIII. | Harrison Co..... | 2.44 | 32.36 | 59.92 | 5.28 | 2.62 |

The following are average figures for some Ohio coals by Lord and Haas. See Chapter V, on "Heating Value of Coal."

| | | | | | |
|---|------|-------|-------|------|------|
| Upper Freeport Bed..... | 1.93 | 37.35 | 51.63 | 9.10 | 2.89 |
| Middle Kittanning Bed (Hocking Valley)..... | 6.59 | 35.77 | 49.64 | 8.00 | 1.59 |
| Jackson Co..... | 8.17 | 35.79 | 52.78 | 3.25 | 1.13 |

THE NORTHERN OR MICHIGAN COAL-FIELD.

The coal deposits of Michigan are detached from those of any other State, and form what is known as the Northern field. The area is about 6700 square miles, the central point being near the town of St. Louis, in Gratiot County, and the southern boundary passing a few miles south of Jackson, in Jackson County. Beyond this to the south there are several detached patches of productive coal-measures. The greatest thickness of the measures is found along a line extending from Ionia County to Saginaw, the thickest coal-beds lying along Six Mile Creek. There is one seam of bituminous coal, 3 or 4 ft. thick, and toward the centre of the basin there are several other beds. One analysis gives: Moisture, 2; volatile matter, 49; fixed carbon, 45; ash, 2; sulphur, 2. The principal operations are carried on near the city of Jackson, in Jackson County, but these are small when compared with other States.

The Michigan coals are of inferior quality when compared to those shipped by lake and rail into the State, and the imported coals are sold so cheap that there is little encouragement for the development of the Michigan field.

THE ILLINOIS COAL-BASIN.

(Indiana, Illinois, and Western Kentucky.)

Indiana.—The Illinois coal-field extends into the western part of Indiana, covering an area of 6500 square miles. The following analyses are given by the State Geological Survey:

ANALYSES OF INDIANA COALS.

| | Moisture. | Volatile Matter. | Fixed Carbon. | Ash. |
|-------------------------|-----------|------------------|---------------|------|
| <i>Caking coals.</i> | | | | |
| Parke Co..... | 4.50 | 45.50 | 45.50 | 4.50 |
| Sullivan Co. coal M.... | 2.35 | 45.25 | 51.60 | 0.80 |
| Clay Co..... | 7.00 | 39.70 | 47.30 | 6.00 |
| Spencer Co., coal L.... | 3.50 | 45.00 | 46.00 | 2.50 |
| <i>Block coals.</i> | | | | |
| Clay Co..... | 8.50 | 31.00 | 57.50 | 3.00 |
| Martin Co..... | 2.50 | 44.75 | 51.25 | 1.50 |
| Daviess Co..... | 5.50 | 36.00 | 53.50 | 5.00 |

The following ultimate and proximate analyses, credited to Noyes, McTaggart, and Craven, are taken from Poole's "Calorific Power of Fuels":

| Locality. | Carbon. | Hydrogen. | Oxygen. | Nitrogen. | Sulphur. | Water. | Ash. | Fixed Carb. | Vol. Matter. |
|-----------------|---------|-----------|---------|-----------|----------|--------|-------|-------------|--------------|
| Brazil..... | 70.50 | 4.76 | 16.29 | 1.36 | 1.39 | 8.98 | 6.28 | 50.30 | 34.49 |
| Lancaster..... | 71.41 | 5.56 | 18.42 | 1.54 | 0.62 | 12.66 | 2.68 | 47.22 | 37.64 |
| New Pittsburg.. | 62.88 | 5.07 | 13.06 | 1.01 | 7.46 | 6.83 | 13.30 | 39.93 | 39.92 |
| " " | 65.26 | 5.17 | 13.25 | 1.17 | 5.88 | 5.89 | 11.48 | 40.40 | 42.23 |
| Shelburn..... | 66.86 | 5.30 | 15.69 | 1.50 | 2.57 | 8.63 | 9.05 | 43.45 | 38.82 |

Western Kentucky.—The Illinois coal-field extends into the north-western portion of the State, including ten counties and portions of five others, having an area of 3888 square miles of coal-measures. There are, in places, twelve beds, but the number varies with the locality. The following analyses are from Prime's Centennial Report on Coal:

| | Moisture. | Volatile Matter. | Fixed Carbon. | Ash. | Sulphur |
|---------------------------|-----------|------------------|---------------|-------|---------|
| Coal A (average)..... | 4.15 | 33.14 | 55.71 | 7.00 | 1.87 |
| " B (average)..... | 3.65 | 38.40 | 51.87 | 6.06 | 3.12 |
| " C (gas-coal layer)..... | 4.60 | 40.10 | 51.35 | 3.95 | 1.49 |
| " D (average)..... | 3.82 | 35.41 | 52.11 | 8.41 | 3.33 |
| " J (Christian Co.)..... | 3.70 | 32.56 | 50.04 | 13.70 | 3.72 |
| " L (average)..... | 4.23 | 33.21 | 54.19 | 8.35 | 1.50 |
| Breckenridge canal..... | 1.44 | 62.40 | 28.20 | 7.96 | 2.44 |

The following are from the Geological Survey of Kentucky, 1884, Western Coal-Field, D.:

| | No. of Samples. | Moisture. | Volatile Matter. | Fixed Carbon. | Ash. | Sulphur. |
|----------------------|-----------------|-------------------|---------------------|---------------------|---------------------|-------------------|
| Nolin River District | 3 | { 3.40 to 4.70 | { 30.66 to 33.24 | { 51.70 to 54.94 | { 11.06 to 11.70 | { 1.95 to 2.54 |
| Muhlenberg Co. | 7 | { 3.60 to 7.06 | { 30.60 to 38.70 | { 50.50 to 58.80 | { 3.40 to 9.20 | { 0.79 to 4.57 |
| Hancock Co. | 7 | { 3.30 to 7.46 | { 33.14 to 43.40 | { 45.56 to 55.20 | { 4.20 to 11.00 | { 1.32 to 4.04 |
| Ohio Co. | 5 | { 3.70 to 5.30 | { 30.70 to 45.70 | { 45.00 to 55.30 | { 3.16 to 14.20 | { 1.24 to 3.13 |
| Breckenridge Cannel | 4 | { 0.64 to 1.44 | { 54.40 to 62.40 | { 27.00 to 32.00 | { 7.96 to 12.30 | { 1.89 |

The Nolin River district embraces portions of Grayson, Edmonson, Hart, and Butler counties.

Illinois.—The coal-field of Illinois occupies an area of 36,800 square miles, or nearly two-thirds of the area of the State. The coal-measures contain six beds of workable size, with a total thickness of 24 ft., but the beds are irregular, often wanting, and often containing an inferior quality of coal. In the DuQuoin district, Perry Co., two seams, V and VI, 6 to 7 ft. thick, are worked within 75 ft. of the surface. In the Big Muddy district, Jackson Co., the coal occurs near the surface. The lower seams produce a good block coal. From the Belleville district, St. Clair Co., St. Louis obtains most of its bituminous coal. Coal seam VI, 5 to 7 ft. thick, is principally worked. The lower seams contain more sulphur and the quality varies. Other large producing districts are at Neelysville, Danville, and La Salle. The latter is of importance from its proximity to Chicago. There are three workable beds, VI, 4½ to 5 ft.; V, 3 to 9 ft., usually 6 ft.; II, 4 ft. The coal of the upper bed, No. VI, is light, dry, and free-burning. No. V is a purer coal. No. II is most highly bituminous, cakes in burning, is high in sulphur, and throws off heavy soot. In the Wilmington district, Will Co., there is a workable seam of coal which is largely used for household and steam purposes. The Illinois coals are generally high in moisture, and are often very high in sulphur and ash. When burned in ordinary furnaces they produce great volumes of black smoke.

Notes to the Table of Analyses of Illinois Coals.—The sources of information from which these analyses were obtained are the following, referring to the figures prefixed to the names of the towns: 1. Proceedings Engineers' Club of St. Louis, as given in Wickes

Bros.' catalogue. 2. D. L. Barnes, *Trans. A. S. C. E.*, 1893. 3, 4. Catalogue of Wickes Bros., credited respectively to McConney and Forsyth. 5. Analyses and calorimetric determinations (by the Carpenter calorimeter) made for the author by C. W. Houghton, M.E., at Cornell University in 1896. 6. William H. Bryan, Engineers' Club of St. Louis, 1896, average of four analyses. 7. Analysis of Staunton coal made for the author by the Pittsburg Testing Laboratory in 1883 (*Trans. A. S. M. E.*, vol. iv, p. 256). This particular coal gave the lowest result the author has ever obtained in a boiler test, viz., 5.09 lbs. of water evaporated from and at 212° per lb. of coal, and 6.7 lbs. per lb. of dry combustible, the ash and refuse obtained in the test being 17.7%, and the moisture in the coal, by analysis, 6.3%. The boiler in this case, having 3358 sq. ft. of heating surface, and rated at 292 H.P., developed only 246 H.P., with a grate-surface of 60 sq. ft. and a good draft, burning 25.1 lbs. of coal per sq. ft. of grate per hour; while with Jackson Co., Ohio, coal, the same boiler, with the grate-surface cut down to 48 sq. ft., and burning only 17.7 lbs. of coal per sq. ft. of grate per hour, developed 460 H.P., or over 57% above rating, with an evaporation from and at 212° of 8.93 lbs. per lb. of coal and 9.88 lbs. per lb. of combustible, not corrected for moisture in the coal. The analysis of this Staunton coal shows a far higher percentage of volatile matter in the combustible (68.5%) than any other of the Illinois coals thus far reported, and nearly the same as that shown by the Breckenridge cannel-coal of Kentucky. During the boiler test the coal gave off dense volumes of jet-black smoke for a minute or two after each firing. The furnace was evidently not adapted for burning this kind of coal.

Another analysis of Staunton coal is given in Poole's "Calorific Power of Fuels," credited to Prof. Carpenter, as follows: Dry coal, volatile matter, 36.0; fixed carbon, 48.0; ash, 16.0; volatile matter per cent of combustible, 42.9. This is very different from the highly volatile coal mentioned above, and is practically identical with the Mt. Olive coal from the same county.

An analysis of Collinsville, Madison Co., coal, forty miles south of Staunton, found in Wickes Bros.' catalogue, credited to Engineers' Club of St. Louis, but not included in the table, is: Water, 5.3; volatile matter, 43.9; fixed carbon, 31.6; ash, 9.2; volatile matter per cent of combustible, 58.1. This analysis approaches that of the volatile Staunton coal and differs greatly from the analysis of Collinsville coal given in the table.

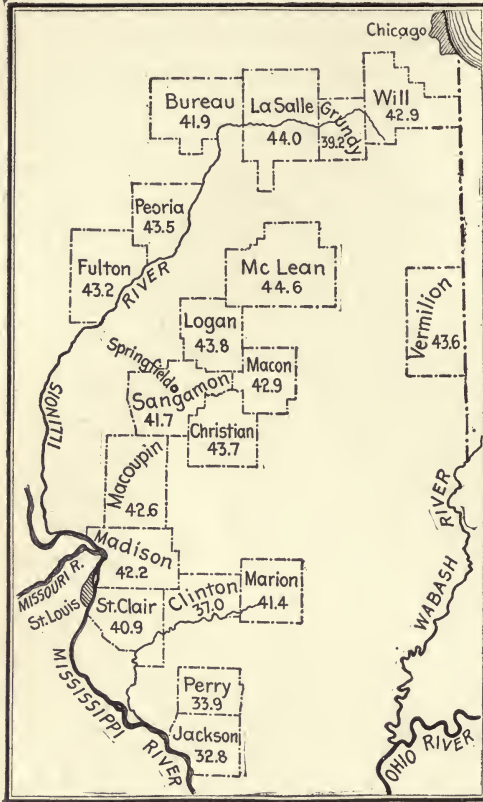

NOTE TO THE MAP.

The accompanying skeleton map shows the relative locations of the counties of Illinois mentioned in the table, with the average percentage of volatile matter in the combustibles of the coal in each county. The highly volatile Staunton coal is not included in the average of Macoupin Co.

It will be noted that the coals in the southern part of the State are much lower in volatile matter than those in the central and northern parts. The author will be glad to fill up the blank spaces in this map in future editions of this work if he is furnished with the necessary data.

FIG. 4.—RELATIVE POSITION OF THE COUNTIES OF ILLINOIS NAMED IN THE TABLE OF ANALYSES OF ILLINOIS COALS.

ANALYSES OF ILLINOIS COALS.

| County. | Town or District. | Moisture. | Volatile Matter. | Fixed Carbon. | Ash. | Sulphur. | Volatile Matter, per cent of Combustible. | Heating Value per pound Combustible, B.T.U. |
|----------------|-------------------------------|-----------|------------------|---------------|------|----------|---|---|
| Bureau | ¹ Colchester..... | 11.6 | 25.0 | 44.8 | 18.6 | ... | 35.8 | 14,700 |
| | ⁵ Ladd..... | 12.0 | 32.3 | 42.5 | 13.2 | ... | 43.2 | |
| | ⁴ "..... | 8.5 | 33.5 | 44.1 | 13.8 | ... | 43.2 | |
| Christian..... | ⁵ Seatonville..... | 10.0 | 33.8 | 40.9 | 15.3 | ... | 45.3 | 14,500 |
| | ³ Pana..... | 7.2 | 36.4 | 46.9 | 9.5 | ... | 43.7 | |
| Clinton..... | ¹ Trenton..... | 13.3 | 30.4 | 52.0 | 4.3 | 0.9 | 37.0 | |
| Fulton..... | ⁴ Bryant..... | 2.4 | 32.9 | 42.6 | 22.0 | ... | 43.6 | |
| | Canton..... | 3.5 | 37.0 | 46.7 | 12.8 | ... | 44.2 | |
| | ⁴ Claire..... | 3.2 | 32.9 | 43.1 | 20.8 | ... | 43.3 | |

ANALYSES OF ILLINOIS COALS—Continued.

| County. | Town or District. | Moisture. | Volatile Matter. | Fixed Carbon. | Ash. | Sulphur. | Volatile Matter, per cent of Combustible. | Heating Value per pound Combustible. | B.T.U. |
|----------------|-----------------------------------|-----------|------------------|---------------|------|----------|---|--------------------------------------|--------|
| Fulton..... | ⁴ Cuba..... | 4.2 | 36.4 | 48.6 | 10.8 | | 42.8 | | |
| | ⁴ Dunfermline..... | 2.5 | 32.9 | 45.6 | 19.1 | | 43.2 | | |
| | ⁴ Farmington..... | 3.4 | 33.9 | 45.9 | 16.8 | .. | 42.5 | | |
| Grundy..... | ⁴ St. David..... | 2.0 | 34.6 | 46.2 | 17.2 | | 42.8 | | |
| | ⁴ Morris..... | 7.1 | 32.1 | 49.7 | 11.1 | | 39.2 | | |
| | ¹ Big Muddy..... | 6.4 | 30.6 | 54.6 | 8.3 | 1.5 | 35.9 | | |
| Jackson..... | ⁵ " " *..... | 7.7 | 31.9 | 53.0 | 7.4 | | 37.6 | 14,550 | |
| | ² Carbondale..... | 6.4 | 26.4 | 59.8 | 7.4 | | 30.6 | | |
| | ² Mt. Carbon..... | 6.1 | 24.7 | 66.5 | 2.7 | | 27.1 | | |
| La Salle..... | ² La Salle..... | 8.2 | 39.4 | 44.0 | 8.4 | | 43.8 | | |
| | ³ Peru..... | 6.6 | 37.2 | 47.2 | 9.0 | | 44.1 | | |
| | ¹ Streator..... | 12.0 | 35.3 | 48.8 | 3.9 | 2.4 | 42.0 | | |
| Logan..... | ² " "..... | 7.2 | 38.9 | 45.3 | 8.6 | | 46.2 | | |
| | ⁵ " " †..... | 9.9 | 33.2 | 42.2 | 14.6 | | 44.0 | 14,200 | |
| | ³ Lincoln..... | 8.4 | 35.0 | 44.5 | 12.1 | | 44.0 | | |
| Macon..... | ³ Mt. Pulaski..... | 7.7 | 35.8 | 46.5 | 10.0 | | 43.5 | | |
| | ³ Niantic..... | 7.9 | 36.3 | 47.4 | 8.5 | | 42.9 | | |
| | ¹ Gillespie..... | 12.6 | 30.6 | 45.3 | 11.5 | 1.5 | 40.3 | | |
| Macoupin..... | ¹ Girard..... | 9.7 | 34.4 | 45.8 | 10.1 | 3.5 | 42.9 | | |
| | ¹ Mt. Olive..... | 10.4 | 36.7 | 46.1 | 6.8 | 3.5 | 44.3 | | |
| | ⁵ " "..... | 8.1 | 33.1 | 44.1 | 14.7 | | 42.9 | 13,700 | |
| Madison..... | ⁷ Staunton..... | 6.3 | 57.1 | 26.3 | 10.3 | | 68.5 | | |
| | ⁶ Collinsville..... | 9.3 | 29.9 | 40.8 | 16.1 | 3.9 | 42.2 | | |
| | ³ Centralia..... | 8.3 | 34.0 | 45.5 | 8.0 | | 42.8 | | |
| Marion..... | ³ Odin..... | 6.1 | 34.0 | 50.9 | 9.1 | | 40.0 | | |
| | ³ Bloomington..... | 4.1 | 36.4 | 45.2 | 14.7 | | 44.6 | | |
| | ⁴ Edwards..... | 1.9 | 34.5 | 43.6 | 20.0 | | 44.2 | | |
| McLean..... | ⁴ Elnwood..... | 1.4 | 27.7 | 35.4 | 35.5 | | 43.9 | | |
| | ⁴ Peoria..... | 3.2 | 36.1 | 49.2 | 11.4 | | 42.3 | | |
| | ⁴ Pottstown..... | 4.6 | 35.5 | 45.5 | 14.4 | | 43.8 | | |
| Peoria..... | ¹ Du Quoin..... | 11.3 | 30.3 | 49.9 | 8.5 | 0.9 | 37.8 | | |
| | ² " "..... | 8.9 | 23.5 | 60.6 | 7.0 | | 28.0 | | |
| | ¹ St. John..... | 13.6 | 24.5 | 43.5 | 15.4 | 1.8 | 36.0 | | |
| Sangamon..... | ² Barclay..... | 10.8 | 27.3 | 44.8 | 17.1 | | 37.9 | | |
| | ³ " "..... | 7.4 | 35.7 | 46.2 | 10.7 | | 43.6 | | |
| | ¹ Loose's..... | 10.7 | 37.6 | 45.1 | 6.6 | 2.4 | 45.5 | | |
| St. Clair..... | ⁵ Riverton..... | 6.4 | 35.4 | 48.4 | 9.8 | | 42.2 | | |
| | ¹ Heintz Bluff..... | 9.0 | 37.8 | 48.2 | 5.0 | 3.3 | 43.9 | | |
| | ¹ Oakland..... | 8.3 | 34.4 | 43.1 | 14.2 | 4.4 | 44.4 | | |
| Vermilion..... | ¹ St. Bernard..... | 14.4 | 30.9 | 48.4 | 6.4 | 1.4 | 38.8 | | |
| | ¹ Vulcan..... | 10.3 | 27.9 | 49.0 | 12.8 | 0.7 | 36.3 | | |
| | ² Danville..... | 11.0 | 32.6 | 53.0 | 3.6 | | 38.0 | | |
| Will..... | ³ " "..... | 4.8 | 43.7 | 45.4 | 5.2 | | 49.1 | | |
| | ³ " "..... | 5.6 | 37.1 | 46.4 | 10.9 | | 44.3 | | |
| | ⁵ Wilmington Lump..... | 15.5 | 32.8 | 39.9 | 11.8 | | 45.1 | 14,050 | |
| Will..... | ⁵ " Screenings..... | 14.0 | 28.0 | 34.2 | 23.8 | | 45.0 | 13,200 | |
| | ⁵ " washed "..... | 14.5 | 29.5 | 42.9 | 13.1 | | 40.7 | 14,200 | |

* Average of two samples.

† Average of five samples.

The heating values of Illinois coals published in Poole's "Calorific Power of Fuels" and other works were determined mostly by the Thompson calorimeter. They are not considered reliable and have therefore been omitted from the table.

THE MISSOURI COAL-BASIN.

(Iowa, southeastern Nebraska, Missouri, eastern Kansas, Arkansas, Indian Territory, Texas.)

The separation of the Western coal-field, of which Missouri forms an important part, from the Illinois or Central field is made by the Mississippi River and its immediate valley. At one place near the northern border of the Illinois field the present course of the Mississippi cuts through it, a small portion of the Central field being found across the river in Iowa. The two fields are really the same, the barren valley being a narrow one, and in it isolated bodies of coal are found both in Iowa and Missouri. It has been customary, however, to consider them separately.

Iowa.—The Missouri coal-basin occupies nearly one-half of the State. The coal-measures are divided into upper, middle, and lower, the latter of which contains the productive seams, two in number. They are of irregular thickness, sometimes reaching 5 ft. An average of 64 analyses made by the State geologist gives: Moisture, 8.57; Volatile matter, 39.24; Fixed carbon, 45.42; Ash, 6.77.

Four analyses by Forsyth, given below, show a wide range of quality:

| Locality. | Water. | Volatile Matter. | Fixed Carbon. | Ash. | Volatile Matter, per cent of Combustible. |
|----------------|--------|------------------|---------------|-------|---|
| Chisolm..... | 9.18 | 40.42 | 39.58 | 10.82 | 50.5 |
| Flagler's..... | 9.48 | 40.16 | 37.69 | 12.31 | 51.6 |
| Hiteman..... | 4.99 | 35.27 | 25.37 | 34.37 | 58.0 |
| Keb..... | 9.81 | 37.49 | 44.75 | 7.95 | 45.6 |

The coal from Hiteman appears to be a cannel-coal very high in ash.

Missouri.—The coal-measures are contained chiefly in the northern and western portions of the State. An arm of this territory, however, follows the course of the Missouri River eastward for a short distance in the central part of the State, and some coal is also found in the vicinity of St. Louis. The total area included is estimated at about 25,000 square miles, distributed over fifty-seven counties in whole or

in part. All of the coals are of the bituminous variety, with the exception of some limited deposits which approach cannel-coal in character. The bituminous coals have, as a rule, a high percentage of ash compared with the best coals of this character. They are comparatively soft, and deteriorate by exposure or much handling. They also usually carry considerable sulphur in the form of pyrite.

There are 16 seams in three measures, of which seven are of workable thickness. Analyses, by C. G. Brodhead, are as follows:

ANALYSES OF MISSOURI COALS.

| County. | Moisture. | Volatile Matter. | Fixed Carbon. | Ash. | Sulphur. |
|-----------------|-----------|------------------|---------------|-------|----------|
| Ray..... | 10.05 | 38.55 | 45.40 | 6.00 | 2.41 |
| Pettis..... | 3.95 | 33.10 | 46.26 | 16.69 | 4.41 |
| St. Louis..... | 9.55 | 38.28 | 42.99 | 9.18 | |
| Henry..... | 5.14 | 37.91 | 46.82 | 10.13 | |
| La Fayette..... | 6.36 | 36.28 | 47.80 | 9.56 | |
| Johnson..... | 7.29 | 42.27 | 46.95 | 3.49 | |
| Lincoln..... | 8.50 | 39.50 | 46.45 | 5.55 | 2.63 |
| Carroll..... | 2.97 | 36.36 | 47.83 | 12.84 | |
| Saline .. | 6.02 | 40.33 | 42.09 | 11.56 | |
| Livingston..... | 5.38 | 42.27 | 44.98 | 7.37 | |
| Nodaway..... | 3.53 | 42.72 | 40.71 | 13.04 | |
| Callaway..... | 7.43 | 38.90 | 45.85 | 7.82 | |
| Andrew..... | 8.94 | 34.75 | 45.38 | 10.93 | |
| Cass..... | 7.80 | 33.20 | 55.75 | 3.25 | |
| Charlton..... | 5.82 | 38.01 | 54.53 | 1.64 | |
| Macon..... | 12.05 | 40.75 | 43.50 | 3.70 | |

Kansas.—The Kansas coal-measures form a part of the great Western field which passes through the eastern half of the State from Iowa and Missouri into the Indian Territory, with an outlying area of cretaceous lignite to the west and in the northern central part of the State. The main portion of the field occupies, approximately, one-fourth the area of the State.

The coal-measures consist of three kinds of rock formations—sandstones, limestones, and shales. In these are inclosed the beds of coal, which do not occupy anywhere more than one-twentieth of the thickness assigned to the coal-measures, and over large parts of the area there is no coal at all. A few square miles, with one bed of coal 30 inches thick, would be a rich district, and there are several such districts in eastern Kansas. The bottom of the lower coal-measures is the richest horizon of the formations. It is in this horizon, not far from the Spring River boundary, that we have the Weir City and Scammon coal-field, of Cherokee County, and the neighboring coal-fields of Frontenac and Pittsburg, in Crawford County. The thickest and best seam of coal in Kansas is the Cherokee bed, found in Cherokee, Crawford and Labette counties. It extends from the Indian

Territory, entering the State near Chetopa, and runs across the south-east part of Labette County, the west and northwest parts of Cherokee, and southeast part of Crawford, and enters Missouri. A few miles north of Columbus the coal-mining region begins, and we have a series of mining towns—Scammon, Weir City, Cherokee, Fleming, Frontenac, Pittsburg, Arcadia, Minden—around which the coal seam, whose average thickness is over 40 inches, is worked.

Arkansas.—The coal-measures cover an area of 9043 square miles along the course of the Arkansas River in the western part of the State. Two beds have been opened, but only the lower is of workable thickness. The best coal yet found in the State is the Spadra, in Johnson County, $3\frac{1}{2}$ feet thick in some places. The following analyses are given by Macfarlane:

| | Moisture. | Volatile Matter. | Fixed Carbon. | Ash. |
|--------------------------|-----------|------------------|---------------|------|
| Sebastian Co..... | 1.40 | 12.35 | 82.25 | 4.00 |
| Long's..... | 3.80 | 10.70 | 84.10 | 1.40 |
| Yell Co..... | 3.00 | 11.40 | 80.40 | 5.20 |
| Johnson Co. (11 in.).... | 2.00 | 7.75 | 88.75 | 1.50 |
| Crawford Co. (1 ft.) ... | 1.00 | 15.20 | 80.80 | 3.00 |
| Spadra Creek..... | 0.50 | 7.90 | 85.60 | 6.00 |

The analyses show these coals to range from semi-anthracite to semi-bituminous.

The following analyses and descriptions of Arkansas coals, made in the geological survey of the State by Dr. R. N. Brackett and Mr. J. P. Smith, were published in "Mineral Resources" for 1888:

| Names of Mines. | Counties. | Chemical Composition. | | | | |
|---------------------------------|-----------|-----------------------|--------------------|---------------|-------|----------|
| | | Water. | Vol. Hydro-carbon. | Fixed Carbon. | Ash. | Sulphur. |
| Hackett City shaft... | Sebastian | 0.85 | 14.92 | 73.87 | 9.04 | 1.32 |
| Huntington slope.... | do | 0.93 | 15.55 | 77.54 | 4.85 | 1.14 |
| Greenwood shaft..... | do | 0.82 | 14.87 | 75.82 | 5.97 | 2.52 |
| Gwynn drift..... | do | 0.89 | 14.58 | 77.09 | 6.25 | 1.19 |
| Western Coal and Mining Company | | | | | | |
| Petty slope..... | do | 1.78 | 13.33 | 76.23 | 7.05 | 1.63 |
| Philpott shaft..... | Johnson | 0.87 | 14.13 | 80.92 | 3.09 | 0.99 |
| Felker slope..... | Franklin | 1.13 | 13.21 | 81.23 | 3.22 | 1.16 |
| Ouita slope..... | Pope | 0.98 | 12.20 | 76.82 | 8.17 | 1.83 |
| Eureka shaft..... | Johnson | 1.10 | 11.28 | 72.84 | 12.04 | 2.75 |
| Coal Hill shaft..... | do | 1.02 | 10.84 | 76.12 | 8.35 | 3.67 |
| Allister slope..... | do | 1.18 | 10.48 | 76.49 | 8.32 | 3.53 |
| Shinn slope..... | Pope | 1.06 | 8.41 | 75.43 | 11.75 | 3.35 |

The above coals are mostly semi-bituminous. To the eye they all present more or less the appearance of soft bituminous coal with a cuboidal fracture. There seems to be no approach in any to the hard, compact, glistening anthracite, with the semi-conchoidal fracture. But despite these facts of proximate composition there are several coals of this list which from their mode of burning deserve to be classed as semi-anthracites. These are the coals from the Ouita, the Eureka, and the Shinn openings. The remaining coals are all of the nature of semi-bituminous coals.

Arkansas coals are all more or less soft and friable, and not well adapted to long transportation. This characteristic is variable in different openings. They all burn freely and make little smoke or soot. For reaching the best results, however, a grate with small openings is necessary, as these coals are liable to decrepitate and to fall through the grate. Coal Hill coal makes an intensely hot fire, producing steam rapidly; but it clinkers and is severe in its action upon grate-bars. It slacks a good deal on exposure, and in burning much fine coal is lost through ordinary grate-bars. Sebastian County coal is easily ignited and quick-burning, but does not produce quite so intense a heat as does the Coal Hill coal; it does not clinker, but leaves a loose ash. The Ouita and Eureka coals are not considered good for steaming purposes.

Indian Territory.—The coal-measures cover 13,600 square miles. At McAlester there is an extensive bed of bituminous gas- and steam-coal, which is also worked at Savannah, 10 miles south, and at Atoka, 45 miles south. H. M. Chance (Trans. A. I. M. E., 1890) says:

The Choctaw coal-field is a direct westward extension of the Arkansas coal-field, but its coals are not like Arkansas coals, except in the country immediately adjoining the Arkansas line.

In the Mitchell basin, about 10 miles west from the Arkansas line, coal recently opened shows 19% volatile matter; the Mayberry coal, about 8 miles farther west, contains 23% volatile matter; and the Bryan Mine coal, about the same distance west, shows 26% volatile matter. About 30 miles farther west, the coal shows from 38 to 41½ per cent volatile matter, which is also about the percentage in coals of the McAlester and Lehigh districts.

ANALYSES OF INDIAN TERRITORY COALS.

| | Water. | Volatile Matter. | Fixed Carbon. | Ash. | Sulphur. |
|---------------------------|--------|------------------|---------------|-------|----------|
| Mitchell Basin..... | 1.06 | 19.03 | 71.74 | 7.53 | 0.65 |
| Grady Basin..... | 1.79 | 40.21 | 51.79 | 4.88 | 1.33 |
| McKinney District..... | 1.71 | 38.67 | 51.48 | 7.14 | 1.01 |
| Krebs, McAlester bed..... | 1.80 | 37.17 | 53.40 | 6.73 | 0.90 |
| Lehigh mines..... | 4.32 | 40.51 | 48.47 | 8.10 | 2.60 |
| Atoka..... | 6.66 | 35.42 | 57.52 | 6.60 | 3.73 |
| Choctaw Nation..... | 1.59 | 23.31 | 66.85 | 8.25 | 1.18 |
| Cherokee..... | 3.62 | 29.51 | 48.09 | 14.78 | 4.00 |
| “..... | 4.07 | 27.67 | 42.12 | 20.20 | 5.94 |

“Mineral Resources” for 1889 says of the coals of the McAlester bed mined at McAlester, Krebs, and Alderson, and the Grady bed mined at Hartshorne, “These coals compare favorably with the best gas-coals mined in the country (as comparison with standard Pittsburg coal will show), and they are by far the best coals now mined in the Southwest, if not indeed the best mined west of the Mississippi River. They are in every way vastly superior to Kansas, Missouri, and Iowa coals.”

Texas.—A detached portion of the great Missouri coal-field covers the northeastern portion of the State for about 6000 sq. miles. The coal is a regular bituminous of the Carboniferous age. Some beds are from 3 ft. to 6 ft. thick. The coal is usually of poor quality, high in ash and sulphur. Three analyses gave the following:

| Localities. | Moisture. | Vol. Mat. | Fixed Carbon. | Ash. | Sulphur. |
|-----------------|-----------|-----------|---------------|-------|----------|
| Young Co..... | 10.00 | 30.75 | 46.59 | 11.96 | 0.70 |
| Fort Worth..... | 14.42 | 30.03 | 42.53 | 13.02 | 1.47 |
| “..... | 4.60 | 34.72 | 49.27 | 11.41 | 1.56 |

Cannel-coal and semi-anthracite are also been found in Texas. In the Cretaceous and Laramie coal-fields of the Rio Grande, near Eagle Pass, bituminous coal of good quality is found. It is superior to the Carboniferous coals of the State, but to the eastward the beds are lignite and impure. Lignites, mostly of very poor quality, containing 10 to 20 per cent moisture even when sun-dried, are found in many deposits in the eastern part of the State. The San Tomas, Webb Co., coal, which has the appearance of being an altered lignite, is a very serviceable fuel, and is largely used in Laredo and on the Mexican National Railroad.

COALS WEST OF THE NINETY-SEVENTH MERIDIAN.

Colorado Coals.—The Colorado coals are of extremely variable composition, ranging all the way from lignite to anthracite. G. C. Hewitt (Trans. A. I. M. E., xvii. 377) says: The coal-seams, where unchanged

by heat and flexure, carry a lignite containing from 5 to 20 per cent of water. In the southeastern corner of the field the same have been metamorphosed so that in four miles the same seams are an anthracite, coking, and dry coal. In the basin of Coal Creek the coals are extremely fat, and produce a hard, bright, sonorous coke. North of Coal Basin half a mile of development shows a gradual change from a good coking coal with patches of dry coal to a dry coal that will barely agglutinate in a beehive oven. In another half mile the same seam is dry. In this transition area, a small cross-fault makes the coal fat for twenty or more feet on either side. The dry seams also present wide chemical and physical changes in short distances. A soft and loosely bedded coal has in a hundred feet become compact and hard without the intervention of a fault. A couple of hundred feet has reduced the water of combination from 12 to 5 per cent.

ANALYSES OF COLORADO COALS.

| | Moisture. | Vol. Mat. | Fixed Carbon. | Ash. | Sulphur. |
|------------------------------|-----------|-----------|---------------|-------|----------|
| Sunshine, Colo., average.... | 2.8 | 36.3 | 37.1 | 23.8 | |
| Newcastle, " " | 1.7 | 37.95 | 48.6 | 11.6 | |
| El Moro, " " | 1.32 | 38.23 | 55.86 | 3.59 | |
| Crested Buttes, " | 1.10 | 23.20 | 72.60 | 3.10 | |
| Lenox, Huerfano Co..... | 2.92 | 41.18 | 45.36 | 10.54 | 1.39 |
| Rouse, " "..... | 2.66 | 36.71 | 51.41 | 9.22 | 1.37 |
| Chicosa, Las Animas Co.... | 0.20 | 28.94 | 64.51 | 6.35 | 0.27 |
| Victor, " " ".... | 1.26 | 36.40 | 53.10 | 9.24 | 1.11 |
| Fairmount vein, La Plata Co. | 1.25 | 39.71 | 52.90 | 6.14 | |
| Porter vein, " " ".... | 0.63 | 34.70 | 57.30 | 7.37 | 0.74 |

LIGNITES AND LIGNITIC COALS OF THE WESTERN STATES.

Lignite is the next stage above peat in the formation of coal. It varies greatly both in appearance and in chemical composition. Its color ranges from light yellow to deep brown or black. The lignites belong to a later geologic period than the Carboniferous. They occur principally in Cretaceous and Tertiary formations. The beds, which are often of great thickness, present the same general characteristics as those of the true coals. Many instances occur in which portions of beds of lignite have changed to bituminous and even to anthracite. The lignites of Western America resemble the "brown coals" of Europe in holding a large amount of water, the percentage in most of them being from 12 to 15, though some have as low as 4 and others as high as 20 per cent. The percentage of ash is usually low, from 2 to 9 per cent, while the sulphur is generally below 1 per

cent. The following analyses are given by Dr. R. W. Raymond in Trans. A. I. M. E., vol. ii., 1873:

| | C. | H. | N. | O. | S. | Moist- ure. | Ash. |
|--------------------------|-------|------|-------|-------|------|----------------|------|
| Monte Diablo, Cal..... | 59.72 | 5.08 | 1.01 | 15.69 | 3.92 | 8.94 | 5.64 |
| Weber Cañon, Utah..... | 64.84 | 4.34 | 1.29 | 15.52 | 1.60 | 9.41 | 3.00 |
| Echo Cañon, Utah..... | 69.84 | 3.90 | 1.93 | 10.99 | 0.77 | 9.17 | 3.40 |
| Carbon Station, Wyo..... | 64.99 | 3.76 | 1.74 | 15.20 | 1.07 | 11.56 | 1.68 |
| “ “ “ | 69.14 | 4.36 | 1.25 | 9.54 | 1.03 | 8.06 | 6.62 |
| Coos Bay, Oregon..... | 56.24 | 3.38 | 0.42 | 21.82 | 0.81 | 13.28 | 4.05 |
| Alaska..... | 55.79 | 3.26 | 0.61 | 19.01 | 0.63 | 16.52 | 4.18 |
| “ | 67.67 | 4.66 | 1.58 | 12.80 | 0.92 | 3.08 | 9.28 |
| Canon City, Colo..... | 67.58 | 7.42 | | 13.42 | 0.63 | 5.18 | 5.77 |
| Baker Co., Ore..... | 60.72 | 4.30 | | 14.42 | 2.08 | 14.68 | 3.80 |

Wyoming.—In the Green River coal-basin in southwestern Wyoming 250 ft. of coal is found in a thickness of about 3000 ft. of coal-measures. The beds are numerous, and many of them are of workable thickness. Analyses and heating values of various coals in this territory are given in Chapter V, on the Heating Value of Coal.

New Mexico.—The coals of New Mexico are lignitic coals of the Cretaceous and Tertiary formations, in all the grades from anthracite to true lignite. They are chiefly used by the railroads crossing the Territory.

ANALYSES.

| | Water. | Volatile Matter. | Fixed Carbon. | Ash. | Sulphur. |
|---------------------------|--------|---------------------|------------------|-------|----------|
| White Oaks, Lincoln Ce... | 2.35 | 35.53 | 50.24 | 11.88 | 0.61 |
| Vermejo Pass..... | 3.27 | 23.73 | 59.72 | 13.28 | |
| Placer anthracite..... | 2.90 | 3.18 | 88.91 | 5.21 | |

Arizona.—Several beds of lignitic coal of extremely variable composition have been found in the Territory. Two analyses of coals from Deer Creek, Ariz., taken from locations 8 miles apart are given below. The first is a semi-bituminous coal; the second, a lignite:

| | I. | II. |
|--|------|------|
| Volatile combustible matter and water..... | 14.5 | 47.6 |
| Fixed carbon | 61.0 | 44.0 |
| Ash..... | 24.5 | 8.4 |

Utah.—The Green River coal-basin contains, according to Clarence King's "Geological Exploration of the 40th Parallel," "a practically inexhaustible supply of coal." Beds from 7 to 25 feet thick are discovered at intervals over 500 miles, and from their ordinary gentle dip may be mined with unusual ease. Two analyses are as follows:

| | Moisture. | Vol. Mat. | Fixed Carbon. | Ash. | Sulphur. |
|-----------------|-----------|-----------|---------------|------|----------|
| Castledale..... | 3.43 | 42.81 | 47.81* | 9.73 | |
| Cedar City.... | 3.50 | 43.66 | 43.11* | 5.95 | |

* Includes sulphur, which is very high. Coke from Cedar City analyzed: Water and volatile matter, 1.42; fixed carbon, 76.70; ash, 16.61; sulphur, 5.27.

Montana.—The coals of Montana are all of Cretaceous age. They embrace a wide variety of true bituminous coals, found only in or near the mountains, and the inferior lignites whose seams form prominent parts of the series of rocks that underlie the Great Plains country. These lignites have been mined at a few localities, but their low heating power and rapid crumbling unfit them for general use, and the bituminous coals have occupied the market. The lignites differ from the true coals in two important particulars: they contain a large amount of moisture and they crumble upon exposure soon after mining. The moisture makes them of low heating power, and their rapid crumbling unfits them for transportation and is a serious detriment in burning. An average analysis of the lignites of eastern Montana shows: Water, 12-15; volatile carbon, 40-45; fixed carbon, 30-35; ash, 5-10.

The bituminous coals of Montana occur in small isolated fields within the mountain region and in a great belt of coal land that extends along the eastern front of the Rocky Mountains.

The character of the coals varies widely in different seams and at different fields. Long- and short- flamed, coking and noncoking coals occur sometimes in adjoining seams of the same mine. As a whole the coals contain a high percentage of ash, and would not rank high in more favored localities. Some of the coals, however, are as pure as the best of Wyoming or Colorado fuels.

North Dakota.—The coal of North Dakota is a lignite of inferior quality and does not compare favorably with that brought from other localities. (“Mineral Resources,” 1891.)

Nevada.—A bed of coal, 5 to 6 feet thick, 20 miles east of Eureka, is mined for local consumption.

California.—The Mt. Diablo coal-field contains several beds, which vary greatly in thickness. The coal is of rather inferior quality. Coal has been found in many portions of the State, but the beds are mostly small in extent and the quality poor. Nearly all of the coal of California is lignite, that from Monterey County alone being classed as bituminous. San Francisco is dependent for its coal supply chiefly on coals brought by water from other States and from foreign countries. An analysis of Mt. Diablo coal is as follows:

| | |
|----------------------|-------|
| Moisture..... | 14.69 |
| Volatile matter..... | 33.89 |
| Fixed carbon..... | 46.84 |
| Ash..... | 4.58 |

Oregon.—The developments are confined to the coal-basin in Coos County, though other lignite discoveries have been reported. The field covers several hundred square miles of territory, stretching from the coast 15 or 20 miles inland. The coals are true lignites, very high in water and volatile matter. Coal is loaded direct from the mines at Marshfield to Pacific Ocean steamers and sold principally in San Francisco.

| | Moisture. | Vol. Mat. | Fixed Carbon. | Ash. | Sulphur. |
|---------------------|-----------|-----------|---------------|------|----------|
| Coos Bay | 15.45 | 41.55 | 34.95 | 8.05 | 2.53 |
| " | 17.27 | 44.15 | 32.40 | 6.18 | 1.37 |
| Yaquina Bay..... | 13.03 | 46.20 | 32.60 | 7.10 | 1.07 |
| John Day River..... | 4.55 | 40.00 | 48.19 | 7.26 | .60 |
| " " | 6.54 | 34.45 | 52.41 | 5.95 | .65 |

Washington.—The developed coal-fields lie chiefly in a comparatively narrow belt, running nearly due north and south, through the western portions of Whatcom, Skagit, Snohomish and King counties into Pierce and Thurston counties. Some distance to the east of the southern end of this belt, in Kittitas County, extensive operations have been carried on for a number of years. The main belt extends along the Cascade Range, and important mines have been opened on both the eastern and western slopes of the range. Coal is found also in other localities, notably in Lincoln, Spokane, Cascade, and Okanogan counties. The coals of the State embrace lignite, semi-bituminous, and bituminous. The total area of the coal deposits of Washington has not been determined, but there is no doubt that almost inexhaustible supplies are at hand, not only for the future demand of its population, but sufficient to furnish a basis for profitable traffic for transportation to the entire Pacific Coast. ("Mineral Resources," 1894.)

The Bellingham Bay coal-bed is 14 ft. thick, one-half of which is mined, the lower half being of no value. At Renton two beds are worked, the upper 17 ft. thick, yielding 10 ft. of good coal, and the lower 11 ft. thick, with 8 ft. of good coal. The Seattle mine, 10 miles southeast of Seattle, has two workable beds, 5 ft. and 8 ft., of good coal.

ANALYSES.

| Localities. | Moisture. | Vol. Mat. | Fixed Carbon. | Ash. | Sulphur. |
|---------------------|-----------|-----------|---------------|-------|----------|
| Bellingham Bay..... | 8.39 | 33.26 | 45.59 | 12.66 | |
| Seattle..... | 11.66 | 45.98 | 35.49 | 6.44 | 0.43 |

Alaska.—The coal-fields of Cook Inlet are described in the 17th and 20th Annual Reports of the U. S. Geological Survey. The coal is a low-grade lignite. In appearance it is often hardly more than a compressed mass of carbonized wood. The composition is quite variable, as shown by the following analyses:

| Locality. | Moisture. | Volatile Matter. | Fixed Carbon. | Ash. | Sulphur. |
|----------------------------------|-----------|------------------|---------------|-------|----------|
| Wood-coal, 4 miles W. of Tyonek. | 5.41 | 65.13 | 27.60 | 1.86 | 0.26 |
| 6 miles W. of Tyonek..... | 9.44 | 48.75 | 33.56 | 8.25 | 0.49 |
| Bradley seam, Kachemak Bay... | 12.64 | 43.96 | 37.14 | 6.86 | 0.49 |
| Curtis seam, " " | 11.67 | 52.37 | 21.01 | 14.95 | 0.46 |

Two fields on the southeastern coast, the upper on the shores of Controller Bay, and the lower reaching 40 miles westward from Icy Bay, have been investigated and coal has been found in seams from 10 to 27 ft. thick. The coal has a bright, black lustre and conchoidal fracture, and has all the characteristics of semi-anthracite except hardness and specific gravity. Two analyses are given from samples taken from outcrops at opposite ends of the upper coal-field, showing great uniformity.

| Locality. | Adhering Water. | Volatile Matter. | Fixed Carbon. | Ash. | Sulphur. |
|-----------------------|-----------------|------------------|---------------|------|----------|
| Controller Bay..... } | 0.75 | 13.25 | 82.40 | 3.60 | 0.69 |
| | 0.78 | 13.22 | 80.30 | 5.70 | 2.90 |

CHAPTER V.

TESTS OF THE HEATING VALUE OF AMERICAN AND FOREIGN COALS.

Johnson's Tests of American Coals.—The series of tests of American coals made by Prof. Walter R. Johnson for the United States Navy Department in 1842 and 1843, the report of which was published in a government document covering 600 pages, is often referred to by writers on the subject of coal. The author made a careful study of Prof. Johnson's report, and published his conclusions concerning it, and also concerning the tests of Scheurer-Kestner and Meunier-Dollfus in 1868, in a series of articles entitled "Critical Review of Efficiency Tests of Coals" in *The Engineering and Mining Journal* in October, 1891. It was shown in this review that Johnson's results are of little use in determining the relative value of American coals when burned under the conditions of modern practice. The boiler used by Johnson was of the two-flue type, set only 9 to 10 inches from the grate-bars, the furnace being entirely unsuited for bituminous coal. Some of the anthracites were burned with an excessive air-supply, causing them to give results much below those that may be obtained under favorable conditions. The table on the next page is a condensed summary of the evaporative results obtained from the several coals, as determined by the boiler-tests.

Scheurer-Kestner's Tests of European Coals.—A series of tests of European coals was made by Scheurer-Kestner and Meunier-Dollfus in 1868, and the results were reported in the *Bulletin de la Société Industrielle de Mulhouse*. An excellent study of these tests, with others, is that by M. L. Gruner in his papers on "The Classification and Heating Power of Coals," translated from the French by R. P. Rothwell, and published in the *Engineering and Mining Journal*, July 18th, 1874, *et seq.*

Gruner divides the bituminous coals into five classes as follows:

1. Dry or semi-bituminous anthracitic coals.

RESULTS OF JOHNSON'S TESTS CORRECTED AND COMPARED BY PER CENT OF FIXED CARBON TO TOTAL COMBUSTIBLE.

| Number of Coal, arranged geographically. | Order of Evaporative power per lb. Combustible. | Name of Coal. | Evaporation from and at 212° per lb. Combustible, Johnson's figures corrected by multiplying by 1.066. | Fixed Carbon per cent. of Total Carbon and Volatile Matter. | Volatile Matter per cent. of Total Carbon and Volatile Matter. | Equivalent of Evaporation in Calories.* |
|--|---|----------------------------------|--|---|--|---|
| <i>Anthracites, Penn.</i> | | | | | | |
| 1 | 15 | Beaver Meadow slope No. 3..... | 11.15 | 97.4 | 2.6 | 5988 |
| 2 | 14 | “ “ “ No. 5..... | 11.29 | 97.2 | 2.8 | 6063 |
| 3 | 9 | Forest Improvement..... | 11.52 | 95.6 | 4.4 | 6186 |
| 4 | 8 | Peach Mountain..... | 11.59 | 96.8 | 3.2 | 6224 |
| 5 | 23 | Lehigh..... | 10.26 | 94.4 | 5.6 | 5509 |
| 6 | 11 | Lackawanna..... | 11.47 | 95.7 | 4.3 | 6159 |
| 7 | 10 | Lykens Valley..... | 11.50 | 92.4 | 7.6 | 6176 |
| <i>Semi-Bituminous.</i> | | | | | | |
| 8 | 3 | N. Y. & Md. Mining Co., Md..... | 11.95 | 85.6 | 14.4 | 6417 |
| 9 | 13 | Neff's Cumberland, Md..... | 11.30 | 85.5 | 14.5 | 6068 |
| 10 | 7 | Easby's Md..... | 11.66 | 83.6 | 16.4 | 6261 |
| 11 | 1 | Atkinson & Templeman, Md..... | 12.39 | 83.2 | 16.8 | 6653 |
| 12 | 5 | Easby & Smith's, Md..... | 11.76 | 82.7 | 17.3 | 6315 |
| 13 | 4 | Dauphin & Susquehanna, Pa..... | 11.91 | 84.3 | 15.7 | 6396 |
| 14 | 6 | Blossburg, Pa..... | 11.68 | 83.2 | 16.8 | 6272 |
| 15 | 12 | Lycoming Creek, Pa..... | 11.43 | 83.8 | 16.2 | 6138 |
| 16 | 2 | Quin's Run, Pa..... | 12.02 | 80.1 | 19.9 | 6455 |
| 17 | 20 | Karthaus, Pa..... | 10.54 | 79.1 | 20.9 | 5670 |
| 18 | 16 | Cambria Co., Pa..... | 10.91 | 77.2 | 22.8 | 5859 |
| 19 | 17 | Barr's Deep Run, Va..... | 10.81 | 77.5 | 22.5 | 5805 |
| <i>Bituminous, U. S.</i> | | | | | | |
| 20 | 21 | Crouch & Snead, Va..... | 10.38 | 71.1 | 28.9 | 5574 |
| 21 | 18 | Midlothian (screened), Va..... | 10.63 | 60.9 | 39.1 | 5708 |
| 22 | 19 | Chesterfield Mining Co., Va..... | 10.55 | 64.3 | 35.7 | 5665 |
| 23 | 28 | Tippecanoe, Va..... | 9.15 | 61.3 | 38.7 | 4914 |
| 24 | 24 | Creek Co., Va..... | 9.82 | 65.0 | 35.0 | 5273 |
| 25 | 27 | Clover Hill, Va..... | 9.15 | 63.8 | 36.2 | 4914 |
| 26 | 26 | Pittsburg, Pa..... | 9.54 | 59.9 | 40.1 | 5123 |
| 27 | 31 | Cannelton, Ind..... | 8.24 | 63.2 | 36.8 | 4425 |
| <i>Bituminous, Foreign.</i> | | | | | | |
| 28 | 22 | Pictou, N. S..... | 10.35 | 67.2 | 32.8 | 5558 |
| 29 | 29 | Sidney, N. S..... | 9.06 | 73.9 | 26.1 | 4865 |
| 30 | 30 | Liverpool, Eng..... | 8.80 | 57.8 | 42.2 | 4726 |
| 31 | 25 | Newcastle, Eng..... | 9.78 | 61.4 | 38.6 | 5252 |
| 32 | 32 | Scotch, Scot..... | 8.23 | 54.9 | 45.1 | 4419 |
| 33 | 33 | Dry Pine Wood..... | 5.02 | | | 2696 |

* A calorie is the amount of heat required to raise 1 kilogram of water 1° centigrade = 3.968 B. T. U. When used as a measure of the heating value of a fuel it is the number of units of weight of water which may be heated 1° C. by the combustion of 1 unit of weight of the fuel. The unit of weight may be either a gram, a kilogram or a pound. When thus used a calorie is equivalent to 1.8 British thermal units.

2. Short-flaming, caking, or coking-coals.
3. True coking-coals, or smiths' coals.
4. Long-flaming, caking, or gas-coals.
5. Long-flaming, dry coals.

The range of chemical analysis, theoretical heating power, and value for steam making of European coals as determined by boiler tests is shown in the table on the following page, in which are arranged a number of results of tests and analyses taken by Gruner from Scheurer-Kestner's reports. The total heating power (in calories) is that found by tests with Favre and Silbermann's calorimeter, and it is notably higher than the theoretical power obtained by Dulong's formula, except in the case of the highly bituminous lignite from Bohemia, which is said to resemble a petroleum.

The next to the last column in the table gives the range of the industrial heating power, or steaming power, in calories, of the several classes of Gruner, as determined by boiler tests, and the last column the per cent of this so-called industrial heating power to the total heating power as determined by calorimeters. From this column it appears that the short-flaming, caking, or coking coals containing on an average about 78 parts of fixed carbon in 100 of total combustible, have a higher ratio of industrial to total heating power than the anthracite coals, and a much higher ratio (as 65 to 55) than the long-flaming, dry coals, averaging 55 parts of fixed carbon in 100 of total combustible.

The results in this table are figured upon pure and dry coal, that is, the ash and moisture have been deducted and the calculation made on the basis of the ratio which the fixed carbon bears to the total of fixed carbon and volatile combustible alone. This is a more scientific method than that which includes the moisture and ash, which may be called accidental impurities, and leads to less confusion and to more correct conclusions concerning the influence of the volatile combustible upon the heating power.

The principal results shown in the tables of Johnson's and Scheurer-Kestner's tests are plotted in the diagram on page 88, showing a comparison of the calorimetric and theoretical heating power and the industrial or steaming power of the coals tested by Scheurer-Kestner, and of the average of Gruner's five classes, with the results of Johnson's tests. The upper line of the diagram shows the total heating power of the coals tested by Scheurer-Kestner, arranged from left to right in the order of their percentages of fixed carbon to total com-

HEATING POWER OF COALS, ACCORDING TO SCHEURER-KESTNER AND OTHERS, AS COLLATED BY GRUNER. ARRANGED IN ORDER OF PER CENT OF FIXED CARBON IN PURE DRY FUEL.

| Description of the Fuel. | Proportion of Fixed Carbon in Coke per 100 of Fuel dry and free from Ash. | Elementary Composition. | | | Total actual Heating power, calories. | Heating power according to Dulong's law, calories. | Industrial Heating power in Steam Boilers. | Industrial Heating power per cent of total, average. |
|---|---|-------------------------|-----------------------|---------------------|---------------------------------------|--|--|--|
| | | C. | H. | O+N* | | | | |
| Anthracite coal from the Creusot | 88.1 | 92.36 | 3.66 | 3.98 | 9456 | 8552 | | |
| <i>Gruner's Class 5.</i> Dry or semi-bituminous anthracitic coals | { 82 to 90 | { 92.36 to 93 | { 3.66 to 4. | { 3.98 to 3. | { 9456 to 9500 | { 8552 to 8600 | { 5760 to 6080 | 63.9 |
| Dry-burning coal, St. Paul du Creusot | 84.2 | 90.79 | 4.21 | 4.97 | 9263 | 8683 | | |
| Short-flaming or fat coal, Caaptal du Creusot | 80.4 | 88.48 | 4.41 | 7.11 | 9622 | 8363 | | |
| <i>Gruner's Class 4.</i> Short-flaming, caking or coking | { 74 to 82 | { 88 to 91 | { 5.5 to 4.5 | { 6.5 to 5.5 | { 9300 to 9600 | { 8300 to 8400 | { 5888 to 6400 | 65.0 |
| Caking coal. Anzin | 77.2 | 81.47 | 4.21 | 11.32 | 9257 | 7789 | | |
| Caking coal. Ronchamp | 73.0 | 88.32 | 4.79 | 6.89 | 9077 | 8194 | | |
| <i>Gruner's Class 3.</i> True caking coals, or smiths' coals | { 68 to 74 | { 84 to 89 | { 5. to 4.5 | { 11. to 5.5 | { 8800 to 9300 | { 7800 to 8024 | { 5376 to 5888 | 62.2 |
| Caking coal. Denain | 70.3 | 83.94 | 4.43 | 11.63 | 9050 | 7810 | | |
| Long-flaming coal. Sultzbach | 64.4 | 83.55 | 5.17 | 11.48 | 8603 | 8024 | | |
| <i>Gruner's Class 2.</i> Long flaming, caking or gas-coals. | { 60 to 68 | { 80 to 85 | { 5.8 to 5. | { 14.2 to 10. | { 8500 to 8800 | { 7800 to 5312 | { 4864 to 5312 | 58.8 |
| Long-flaming, caking coal. Duttweiler | 63.5 | 83.82 | 4.60 | 11.58 | 8724 | 7858 | | |
| Long-flaming, dry coal. Montceau | 60.6 | 78.58 | 5.23 | 16.19 | 8325 | 7455 | | |
| Very long-flaming coal. Von der Heydt | 60.4 | 81.56 | 4.98 | 13.46 | 8462 | 7727 | | |
| Long-flaming, dry coal. Louisenthal | 59.0 | 76.87 | 4.68 | 18.45 | 8215 | 7032 | | |
| Long-flaming, semi-caking coal. Friedrichstall | 58.5 | 78.97 | 4.67 | 16.36 | 8457 | 7287 | | |
| <i>Gruner's Class 1.</i> Long-flaming, dry coals | { 50 to 60 | { 72 to 80 | { 5.5 to 4.5 | { 19.5 to 15. | { 8000 to 8500 | { 4288 to 4800 | { 4288 to 4800 | 55.1 |
| Highly bituminous lignite, Bohemia | 55.0 | 76.58 | 8.27 | 15.15 | 7924 | 8387 | | |
| Dry lignite, Rocherbleu | 52.0 | 72.98 | 4.04 | 22.98 | 6480 | 6300 | | |
| Bituminous wood | 51.4 | 67.60 | 4.55 | 27.85 | 6311 | 5831 | | |
| Fossil wood, passing into lignite | 50.4 | 66.51 | 4.72 | 28.77 | 6258 | 5760 | | |
| Fat lignite, Manosque | 48.8 | 70.57 | 5.44 | 23.99 | 7363 | 6542 | | |
| Dry lignite, Manosque | 46.8 | 66.31 | 4.85 | 28.84 | 7006 | 5788 | | |
| Cellulose, C ₁₂ H ₁₀ O ₁₀ | { 28 to 30 | { 44.44 to 61.17 | { 6.17 to 49.39 | | { 3622 to 3590 | | | |

* The nitrogen rarely exceeds 1 per cent.

bustible. The five numbered stars in the line show the position of the averages of Gruner's classes. The next lower heavy line in the diagram shows the theoretical heating value, according to Dulong's law, of the coals tested by Scheurer-Kestner. This value is less than the total value in every case except that of the bituminous lignite. The apparent irregularities in this line as compared with the line representing the total heating value will be referred to hereafter. For comparison with these two lines there has also been inserted the curve

plotted from the more recent results of Mahler, which are hereafter discussed.

Johnson's tests, as shown in the diagram, group themselves into three distinct classes. They are numbered from 1 to 32, in the order

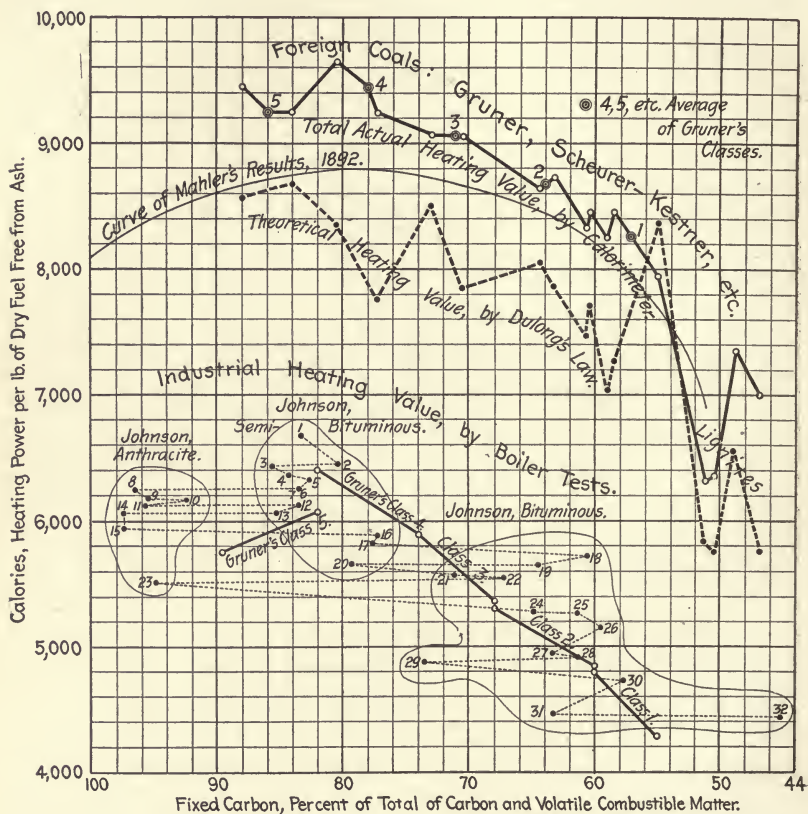

FIG. 5.—COMPARISON OF CALORIMETRIC AND THEORETICAL HEATING POWER AND INDUSTRIAL OR STEAMING POWER OF FOREIGN AND AMERICAN COALS. (GRUNER, SCHEURER-KESTNER, AND JOHNSON.)

of their steaming value. The extreme irregularity of these tests is clearly shown by the position of the numbers. The five short inclined lines included among Johnson's groups represent the range of the industrial value of Gruner's five classes. They show as close an agreement as can be expected with the results of Johnson, and indicate that the efficiency of the coals in actual trial upon which Gruner's figures are based was about as low, on an average, as the efficiency

shown in Johnson's tests. This efficiency, as shown in the last column of the table on page 85, ranged from 65 down to 55 per cent of the total heating value.

In the author's paper in *The Engineering and Mining Journal*, October 31, 1891, the following remarks were made on Scheurer-Kestner's tests:

"In order to find a reason why the theoretical heating power of the coals tested by Scheurer-Kestner is less than the actual heating power as determined by a calorimeter, we have recourse to the translation of Gruner's paper before referred to, from which the following extracts are taken:

"Dulong proposed the formula

$$P = 8080C + 34,462\left(H - \frac{O}{8}\right),$$

where P = heating power, C = weight of carbon, O = weight of oxygen, H = free hydrogen, i.e., total hydrogen less that already burnt to water by the oxygen which the coal contains.

"In this formula the influence of molecular constitution in the calorificity of bodies was ignored, as it was not known that the heat of combustion of a body, simple or compound, is in general greater in proportion as the molecular constitution is less advanced.

"It is now established by the labors of Favre, Silbermann, Regnault, Berthelot, and others, that the heat of combustion, like specific heat, varies with the density.

| | Calories. |
|---|-----------|
| Carbon from charcoal develops..... | 8080 |
| Carbon of gas-retorts, which is more dense..... | 8047 |
| Natural graphite..... | 7797 |
| The diamond only..... | 7770 |

"It follows from this that to apply Dulong's formula to coals we should substitute for the calorific power of hydrogen in a gaseous state that of hydrogen in a solid state, and instead of 8080, which represents the heat of combustion of carbon having a density greater than 2, we should put a greater number, corresponding to the less condensed state of the carbon in coals.

"Favre and Silbermann determined as long ago as 1852 the heat of combustion of the following isometric hydrocarbons, represented by the formula $C_{2n}H_{2n}$:

| | Calories. | | Calories. |
|-------------------------------|-----------|--|-------------------------------|
| Olefiant gas, C_4H_4 ... | 11,858 | | Carbure, $C_{22}H_{22}$ |
| Amylene, $C_{10}H_{10}$... | 11,491 | | 11,262 |
| Paramylene, $C_{20}H_{20}$.. | 11,303 | | Cetene, $C_{32}H_{32}$ |
| | | | 11,118 |
| | | | Metanylene, $C_{40}H_{40}$.. |
| | | | 10,928 |

"From these last five numbers corresponding to liquid hydrocarbon, MM. Favre and Silbermann concluded that with each addition of C_2H_2 .

the heat of combustion diminishes 37.48 calories per unit of weight of the compound. The same diminution of calorific power is found in the ternary compounds. All heat set free in the act of condensation is lost beyond recovery by the act of combustion. Now, coals are ternary compounds condensed to various degrees, and this is why a simple elementary analysis, which determines nothing as to the mode of combination, can teach us nothing as to their calorific power, and therefore does not indicate their industrial value.

“Prof. Stein, of Dresden, goes still further and asserts that ‘an elementary analysis teaches us nothing about the actual properties of coal.’ This assertion appears too general; it is also in opposition to the conscientious work of Regnault, who concluded from his analyses ‘that the elementary composition of coals of the carboniferous formation and of the same quality varies only within very narrow limits.’

“M. Gruner explains the difference between the conclusions of these two chemists by the very great difference in the character of the coals tested by each; we cannot, therefore, he says, ‘generalize the conclusions of Prof. Stein, and they should not be considered as applying to the coals of other fields, nor on the other hand could we admit without restrictions the opposite conclusions of M. Regnault.’

“The elementary composition of coals does not always agree with their essential properties, i.e., with their caking and heating powers. This disagreement shows itself in a very striking manner in the direct determination of the heating power of certain coals, as made by MM. Scheurer-Kestner and Ch. Meunier. These investigations agree also with the general results obtained in industrial tests made by Dr. Brix in Berlin, and by the French and English navies. From a study of these results M. Gruner concludes that ‘the real value of a coal may be better determined by a proximate than by an elementary analysis.’

“The proximate analysis, which consists in distilling coal in a retort and burning the residue, enables us to determine directly the caking power as well as the nature and amount of ash. It is also easy to show, especially by Scheurer-Kestner and Meunier’s work, that the heating power increases and decreases with the proportion of fixed carbon left by the distillation. This is true at least for bituminous coals, but not always for anthracites and lignites.

“Comparing the different numbers in Scheurer-Kestner’s tests, says Gruner, we perceive that several coals almost identical in composition have very different heating power; the heat of combustion increases and decreases with the proportions of coke, and seems to depend especially on the volatile elements.”

Commenting on these observations of Gruner, the author said in *Eng. and Mining Journal*, Oct. 31, 1891:

“Gruner shows that the less the density of any form of carbon, the greater is its heating power. The tests he records also show that coals containing hydrogen give a greater heating power than that calculated by theory from their elementary composition. It would naturally be

inferred, therefore, that the coals which have the least density, and which contain the largest percentage of disposable hydrogen, would have the greatest heating power. Yet, the reverse of this appears to be true, so that after the disposable hydrogen reaches 4% its further increase seems to be actually accompanied by a decrease of heating power, as determined by a calorimeter, and by a still greater relative decrease, as shown in the diminution of efficiency, from 65% to 55%, in the industrial or steaming power.

“It is difficult to explain the anomaly, except upon the hypothesis that the calorimetric determinations of the more volatile coals were inaccurate. This is quite possible, for Scheurer-Kestner and Meunier claim to have improved Favre and Silbermann’s calorimeter so as to render the combustion of carbon more perfect. May it not be possible that they did not so far improve it as to insure the combustion of all the hydrogen in the coals? We know that there is great difficulty in making a complete combustion of the volatile matter of a highly bituminous coal in a boiler test, as was shown in Johnson’s tests, in which dense volumes of smoke escaped from the chimney and the flues were coated with soot, and as also is shown in every-day practice with soft coal. Is it not highly probable that the same difficulty exists in some degree in making complete combustion of these coals in a calorimeter? This difficulty is further indicated by the considerable difference which exists in the result of the calorimetric determinations of the elements as published by different physicists, such as Andrews, Favre and Silbermann, and Depretz.

“There is certainly room for redetermination of these results by modern experimenters with improved apparatus.

“If such tests should be made in the future, I would suggest the following crucial test of a calorimeter, namely, determine carefully the total heating values of a very pure anthracite, low in hydrogen, and of refined petroleum. Then mix the very finely powdered anthracite into a paste with the petroleum in different proportions, and determine the heating value of the mixtures. It should be the same as that calculated from the percentage of the two, and the difference, if any, would indicate the imperfection of the calorimeter for determining the heating power of a fuel, one portion of which is more volatile than the other. It is possible that considerable difficulty would be met with in providing such conditions in a calorimeter that both portions of the mixture could be completely burned at the same time, and this difficulty would always be met in attempting to burn any highly bituminous coal.”

Since the above was published Mahler’s tests in France, and Lord and Haas’s in the United States, have shown that there is an exceedingly close agreement between the heating value determined by a bomb calorimeter of the Berthelot type and that computed from the ultimate analysis by means of the Dulong formula. Scheurer-Kestner’s results are therefore now discredited, and his attempted explanation

of why the theoretical heating power is less than the actual is of no value.

Mahler's Tests of European Coals.—MM. Scheurer-Kestner and Meunier-Dollfus found that the heating power as determined by the Favre and Silbermann calorimeter was notably higher than that calculated from the analysis by means of the Dulong formula. More recently numerous determinations, by different American chemists, of the heating values of various American coals, by means of the Thompson calorimeter or its modifications, showed, apparently, that the heating values of these coals were much less than those calculated from the analyses. The contradictory results of all these researches must now be set aside in view of the work of Mahler, in France, published in 1892, supplemented by the more recent work of Lord and Haas in this country and by that of Bunte in Germany, all of whom agree in showing that the calorimetric values and those calculated by the Dulong formula from the ultimate analysis are nearly identical, except in the case of cannel-coal, lignite, turf, and wood, which by Mahler's tests show a calorimetric value ranging from 2 to 12 per cent higher than that calculated from the analysis.

Mahler's research was made under the auspices of the Société d'Encouragement pour l'Industrie Nationale, with its financial assistance to the extent of 3000 francs, and his report is published as a pamphlet extract from the *Bulletin* of the Société, of 1892, occupying 73 pages quarto, with two large plates. It is entitled "Contribution à l'Etude des Combustibles: Détermination Industrielle de leur Puissance Calorifique. Par P. Mahler, Ingénieur Civil des Mines," etc.

The calorimeter used by Mahler was a modified form of the "calorimetric bomb" of MM. Berthelot and Vielle, described in the *Annales de Physique et de Chimie* in 1881 and 1885. The bomb, with its auxiliary apparatus, is shown in the cut, Fig. 6 on, page 95. It is described in detail in the report, and the description of a similar bomb, used by Professors Slosson and Colburn in their investigations of Wyoming coals, with the method of operating it, is given below.

Mahler's results are shown in condensed form in the table on the opposite page.

Mahler's formula gives the same result as his modification of Dulong's when $O + N = 3.29\%$, and higher results when $O + N$ is greater than 3.29% , but the difference is small, less than 1% , until $O + N$ becomes greater than 10% . The average results for the several classes of coals calculated by the Mahler formula are greater or less

HEATING POWER OF COALS. (P. MAHLER)

| | Kind of Coal. | Coal Dry and Free from Ash. | | | | | | |
|--|--|-----------------------------|--------------|------|--------|-------------------------|---------------------|-------------|
| | | Percent Fixed Carbon. | Composition. | | | Heating power Calories. | | |
| | | | C. | H. | O + N. | Actual. | By Dulong's Formula | Difference. |
| ANTHRACITE AND ANTHRACITIC. | | | | | | | | |
| 1 | Pennsylvania..... | 97.00 | 95.37 | 2.20 | 2.43 | 8256 | 8462 | + 206 |
| 2 | De la Mure (Grand Couche)..... | 97.25 | 95.24 | 1.50 | 3.26 | 8216 | 8173 | - 43 |
| 3 | Hay-Duong (Tonkin)..... | 96.83 | 92.86 | 2.16 | 4.99 | 8121 | 8130 | + 9 |
| 4 | Kebao..... | 94.80 | 93.46 | 3.07 | 3.48 | 8532 | 8528 | - 4 |
| 5 | Commentry..... | 96.81 | 91.49 | 3.12 | 5.39 | 8456 | 8333 | - 123 |
| 6 | Blanzy, Puits Ste.-Barbe..... | 94.00 | 90.00 | 3.17 | 6.83 | 8203 | 8169 | - 34 |
| 7 | Grande-Combe, Puits Petassas..... | 93.29 | 91.46 | 3.95 | 4.59 | 8540 | 8653 | + 113 |
| 8 | Creusot..... | 89.56 | 92.39 | 3.78 | 3.83 | 8637 | 8704 | + 67 |
| | Average..... | | | | | | | + 18 |
| FAT AND SEMI-FAT (DEMI-GRASSE). | | | | | | | | |
| 9 | Demi-grasse, d'Anzin, Fosse St. Marc. | 85.92 | 91.26 | 4.27 | 4.48 | 8656 | 8751 | + 95 |
| 10 | " Grande Combe..... | 86.62 | 91.19 | 4.46 | 4.35 | 8756 | 8817 | + 61 |
| 11 | " Roche-la-Molière..... | 86.00 | 90.11 | 4.38 | 5.51 | 8767 | 8651 | - 116 |
| 12 | " Aniche..... | 88.07 | 90.10 | 4.40 | 5.49 | 8834 | 8659 | - 175 |
| 13 | Grasse, Anzin, great vein..... | 78.49 | 89.20 | 4.67 | 6.14 | 8574 | 8651 | + 77 |
| 14 | " Ronchamp..... | 76.77 | 88.89 | 4.84 | 6.27 | 8797 | 8678 | - 119 |
| 15 | " Lens..... | 80.50 | 90.03 | 4.80 | 5.17 | 8839 | 8805 | - 34 |
| 16 | " Carmaux..... | 78.25 | 87.84 | 4.87 | 7.30 | 8639 | 8559 | - 80 |
| 17 | " Roche-la-Molière..... | 77.15 | 89.53 | 4.84 | 5.63 | 8867 | 8737 | - 130 |
| 18 | " Saint Etienne..... | 79.16 | 89.23 | 5.03 | 5.74 | 8857 | 8796 | - 61 |
| 19 | " Mines de Portes (Gard)..... | 80.71 | 86.52 | 4.84 | 8.64 | 8667 | 8382 | - 285 |
| | Average..... | | | | | | | - 66 |
| FAT GAS-COALS. | | | | | | | | |
| 20 | Bethune..... | 69.59 | 87.03 | 5.37 | 7.60 | 8668 | 8654 | - 14 |
| 21 | Lens..... | 69.20 | 87.26 | 5.44 | 7.30 | 8749 | 8705 | - 44 |
| 22 | Firminy..... | 67.98 | 85.39 | 5.58 | 9.13 | 8573 | 8524 | - 49 |
| 23 | Montrambert..... | 65.73 | 84.52 | 5.54 | 9.94 | 8598 | 8407 | - 191 |
| 24 | Commentry..... | 60.04 | 85.66 | 5.60 | 8.73 | 8408 | 8573 | + 165 |
| 25 | Wigan, Lancashire..... | 68.36 | 88.57 | 5.72 | 5.72 | 8768 | 8979 | + 211 |
| 26 | Cannel-coal, Niddrie..... | 47.00 | 88.79 | 6.57 | 9.63 | 8431 | 8717 | + 286 |
| | Average..... | | | | | | | + 52 |
| FLAMING COALS, LIGNITIC. | | | | | | | | |
| 27 | Montois..... | 62.93 | 83.95 | 5.64 | 10.42 | 8570 | 8371 | - 199 |
| 28 | Blanzy (Puits Ste.-Marie)..... | 68.05 | 84.26 | 5.27 | 10.46 | 8350 | 8271 | - 79 |
| 29 | Decazeville (Bourran)..... | 64.20 | 83.17 | 5.68 | 11.14 | 8270 | 8294 | + 24 |
| 30 | Blanzy (Puits Ste.-Eugénie)..... | 60.61 | 81.54 | 5.64 | 12.83 | 8083 | 8072 | - 11 |
| 31 | Decazeville (Tramont)..... | 58.77 | 78.72 | 5.67 | 15.61 | 7837 | 7735 | - 102 |
| | Average..... | | | | | | | - 74 |
| Average of above four classes..... | | | | | | | | |
| | | | | | | | | - 18 |
| LIGNITES. | | | | | | | | |
| 32 | Terre de Feu..... | 47.23 | 71.01 | 5.94 | 23.05 | 7039 | 6882 | - 157 |
| 33 | Trifail (Styria)..... | 49.66 | 69.24 | 5.06 | 25.71 | 6616 | 6317 | - 299 |
| 34 | Vaurigard..... | 50.05 | 66.36 | 5.01 | 28.63 | 6076 | 5938 | - 138 |
| 35 | TURF FROM BOHEMIA..... | 31.07 | 57.21 | 5.96 | 36.82 | 5903 | 5169 | - 734 |
| WOOD. | | | | | | | | |
| 36 | Partially dry, Sapin de Norvège..... | | 51.08 | 6.02 | 42.90 | 4828 | 4428 | - 400 |
| 37 | Bois de Chêne de Lorraine..... | | 50.44 | 5.88 | 43.69 | 4689 | 4293 | - 396 |
| 38 | Cellulose. C ₁₂ H ₁₀ O ₁₀ | | 44.44 | 6.17 | 49.39 | 4200 | 3617 | - 583 |

* Dulong's formula, slightly modified by Mahler, is: $Q = \frac{1}{100} \left[8140C + 34,500 \left(H - \frac{(O+N)-1}{8} \right) \right]$.

It may be put under the form $Q = \frac{1}{100} [8140C + 34,500H - 4312(O + N - 1)]$.

Mahler's own formula is $Q = \frac{1}{100} [8140C + 34,500H - 3000(O + N)]$.

than the calorimetric results, as follows: Anthracite and anthracitic, +19; fat and semi-fat, -34; fat gas-coals, +117; flaming coals, lignitic, +42; average of these four classes, +26, as compared with -18, the average difference between the results calculated by the modified Dulong formula and the calorimetric result, as shown in the table. For the lignites, turf, and wood, Mahler's formula gives much smaller differences than Dulong's, viz.: +102, +6, +194, -294, +119, +134, +64, as compared with -157, -299, -138, -734, -400, -396, -583, the figures in the table. For all ordinary coals, therefore, Dulong's formula may be considered the more accurate of the two, giving an average difference of only 18 calories in over 8000.

DESCRIPTION OF MAHLER'S BOMB CALORIMETER.*

The essential conditions for the determination of heat of combustion are that the product be completely burned, that the heat pass entirely into the water of the calorimeter vessel, and that the combustion be as quick as possible. These conditions are best attained by the process devised by Berthelot, according to which the combustion takes place in a closed steel vessel (the so-called bomb) filled with oxygen under twenty to twenty-five atmospheres pressure and almost entirely immersed in the water of the calorimeter. Under these circumstances a hydrocarbon burns completely to carbon dioxide and water in a few seconds, none of the products of combustion can escape and the heat passes into the surrounding water in the course of two or three minutes. The high price of Berthelot's calorimeter, about \$1,500, has prevented it from coming into common use. In June, 1892, an account was published of a modification of Berthelot's apparatus invented by M. Mahler in which the expensive platinum lining of the bomb was replaced by a thin coating of enamel without impairing the efficiency of the instrument.† A calorimeter of this kind was procured by the University of Wyoming in July, 1894, for the study of the coal and petroleum of the State and for use in food investigations in the Agricultural Experiment Station.

The bomb (*B* in cut) of our apparatus is 15 cm. high and 10 cm. in diameter, with an average thickness of 8 mm. It is Martin-Sie-

*From an article on "The Heating Power of Wyoming Coal and Oil," by Professors E. E. Slosson and L. C. Colburn, published in a special Bulletin of the University of Wyoming, Laramie, Wyo., January, 1895. Another description will be found in Mahler's paper on "The Calorific Power of Combustibles" (Bulletin de la Société d'Encouragement pour l'Industrie Nationale, Paris, 1892), and in Poole's "Calorific Power of Fuels" (John Wiley & Sons, New York, 1898).

†The apparatus is constructed by M. L. Golaz, Rue Saint-Jacques, Paris, and is sold at the following prices: Mahler's calorimeter complete 750 francs, pump for compressing oxygen 500 francs, pair of thermometers 50 francs. Our instrument was procured through Eimer and Amend, New York.

A cheaper form of the bomb calorimeter, which dispenses with pump or gas-cylinder, is described in Hempel's Gas Analysis.

mens soft-forged steel of a resistance of 50 kilogs. per sq. mm. of section (about 70,000 lbs. per sq. in.), and 20% elongation. It is nickel-plated on the outside and coated on the inside with a thin white enamel to prevent corrosion by the oxygen and the acids which are among the products of combustion. The capacity of the bomb is 580 cc. A platinum tray (*C*), of 30 mm. in diameter and 5 mm. in depth, is suspended from the cover by a rod of platinum. A similar rod passing through the cover, but insulated from it, reaches nearly to the tray and serves as the other electrode. The cover is screwed on

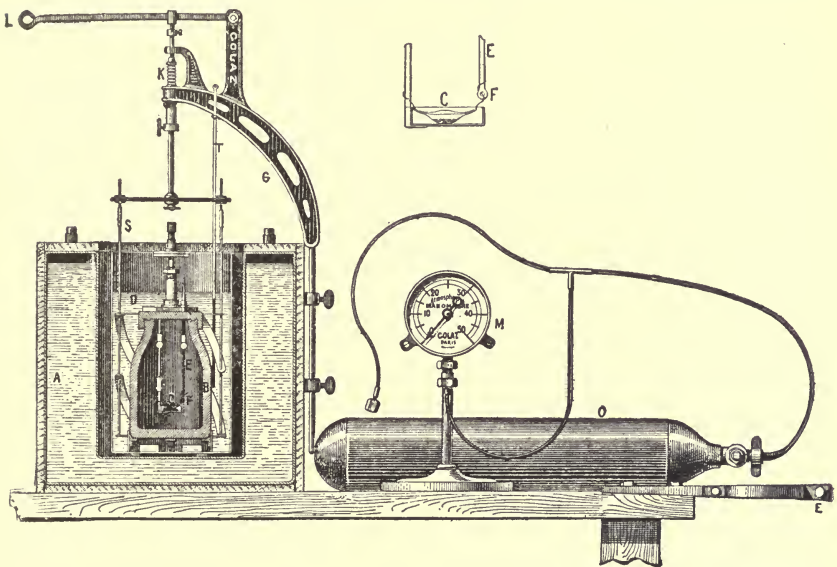

FIG. 6.—MAHLER'S BOMB CALORIMETER.

A, water-jacket; *B*, bomb of enamelled steel; *C*, platinum tray; *D*, calorimeter-vessel; *E*, electrode; *F*, iron wire for ignition; *G*, support for stirring-apparatus; *K*, stirring-mechanism; *L*, lever for stirring; *M*, manometer; *O*, cylinder of oxygen; *S*, stirring-apparatus; *T*, thermometer; *Z*, clamp.

over the top of the bomb and a hermetical joint secured by a ring of lead. The oxygen is passed in through the stem of the needle-valve, which is screwed down when the bomb is filled. The bomb is set in a support which touches the bottom of the calorimeter vessel on three points. The calorimeter vessel is a pail of thin brass, 23 cm. high and 14 cm. diameter. This rests on three points of a light wooden support, and is surrounded by a large double-walled vessel, covered with thick felt, containing water at the normal temperature of the room. An ingenious stirring mechanism enables one to keep the water of the calorimeter in thermal equilibrium with slight effort. The calorimeter is so well isolated from external influences that the water often does

not vary in temperature $.01^{\circ}$ in fifteen minutes, although the air of the room may be quite variable.

Two thermometers were used, one reading between 8° and 18° C., and the other between 18° and 28° ; each degree covering a space of $3\frac{1}{2}$ cm. They are graduated to $\frac{1}{100}^{\circ}$, and were read to 0.01° , although with a glass they can be read to a much finer interval.

The oxygen used was made in the laboratory, purified by passing through a solution of caustic potash and three rolls of copper gauze, and kept in gas-bags; the slight correction indicated for Berthelot for the loss of heat through vaporization of water has not been applied.

THE PROCESS OF COMBUSTION.

One gram of the coal or oil is weighed into the tared platinum tray, which is then attached to the platinum rod in the calorimeter-bomb. A piece of iron wire of known weight is stretched across from the rod supporting the tray to the insulated support, and preferably touching the combustible or buried in it. The bomb is then placed in a lead-lined clamp, and the top tightly screwed on by means of a wrench. The needle-valve is opened and connected with the compression pump by a long slender copper tube. Oxygen is then forced into the bomb until the manometer reads 20 or 25 atmospheres. The needle-valve is closed and disconnected from the filling tube, and the bomb is immersed in the water of the calorimeter. The water should be 2° to 3° lower in temperature than the air of the room and the water in the jacket of the calorimeter, and a sufficient amount should be weighed out to cover the bomb nearly to the top of the insulated electrode. In our instrument 2309 grams of water was usually taken, as that gave with the water value of the apparatus (491 grams) a convenient factor for calculation. The stirring apparatus is kept in motion, and, as soon as the change in temperature becomes constant, readings of the thermometer are taken at intervals of one minute. At the end of the fifth minute the combustible is fired by passing an electric current through the iron wire, raising it to redness. We used a plunge battery of six bichromate cells for this purpose. One wire is connected to the insulated electrode, and the other is touched to some exposed part of the bomb. In about ten seconds the thermometer is observed to rise, rapidly at first, then more slowly, reaching a maximum usually on the second or third minute after firing. After the maximum it falls regularly and slowly if the proper temperature has been chosen for the water, and readings are again made at intervals of a minute for five minutes more. Then the bomb is taken out of the calorimeter, the needle-valve cautiously opened to allow the products of combustion and residual oxygen to escape; after which the bomb is opened and rinsed out with distilled water. The rinsings are titrated with a standard solution of potassium hydrate or sodium carbonate to determine the amount of nitric acid formed by the combustion; and, if the combustible contains sulphur, the solution is set aside for determination of sulphuric acid. The whole operation, including the

weighing of the sample and pumping in the oxygen, can be completed in less than an hour if everything works well.

Multiplying the weight of water taken plus the water value of the apparatus by the corrected rise in temperature gives the heat of combustion of one gram of the substance, subject to the corrections mentioned below.

CORRECTIONS.

1. *Correction for the Influence of the Temperature of the Environment.*—This is the largest and most important correction to be made, although on account of the short interval during which the temperature rises—usually two minutes—it is smaller in this process than in any other.

As there is no way of measuring directly the amount of heat lost or gained by the calorimeter from the moment of firing to the moment when all the heat of combustion has been given up to the water surrounding the bomb, it is necessary to calculate this from the rate of change of temperature before firing and the rate of change when the temperature has come again to equilibrium. This correction is most accurately given by the application of the Regnault-Pfaundler formula. If the preliminary period and the final period are each five minutes, with readings of the thermometer every minute, the correction according to this formula is:

$$[t_6 + t_7 + \dots + t_{N-1} + \frac{t_5 + t_N}{2} - (N - 5)t_M] \frac{D - d}{T - t_M} + (N - 5)d,$$

where t indicates the temperature at the end of the minute designated by the subscript; t_6 is the instant of firing; N is the number of the maximum reading; t_M is the average of the five readings before firing; T is the average of the readings of the final period; D is the average change in temperature during the final period, and d is the average change in temperature during the preliminary period.

As in practice the maximum temperature nearly always occurs on the seventh, the eighth, or the ninth minute, the formula can be reduced for these three cases to the following forms, which are easy to calculate:

When the maximum is the end of the seventh minute the correction for the loss or gain of heat during the minutes 5-6 and 6-7 is

$$\frac{1}{5} \left\{ \frac{[(2t_6 + t_7) - (2t_0 + t_5)] [(t_7 + t_5) - (t_0 + t_{12})]}{(t_{12} + t_7) - (t_0 + t_5)} + 2(t_0 - t_5) \right\}.$$

When the maximum is the eighth minute the loss or gain for the minutes 5-6, 6-7, 7-8 is

$$\frac{1}{5} \left\{ \frac{[(2t_6 + 2t_7 + t_8) - (3t_0 + t_5)] [(t_8 + t_5) - (t_{13} + t_0)]}{(t_{13} + t_8) - (t_0 + t_5)} + 3(t_0 - t_5) \right\}.$$

When the maximum is the ninth minute the loss or gain for the minutes 5-6, 6-7, 7-8, 8-9 is

$$\frac{1}{5} \left\{ \frac{[(2t_6 + 2t_7 + 2t_8 + t_9) - (4t_0 + t_5)][(t_9 + t_5) - (t_{14} + t_0)]}{(t_{14} + t_9) - (t_0 + t_5)} + 4(t_0 - t_5) \right\}.$$

This correction becomes a minimum when the temperature before firing is rising about three times as fast as it falls after the maximum.

As the period of combustion is so short M. Mahler has given a method of correction based on Newton's law which gives results sufficiently exact for technical work. His rules are:

I. The law of decrease of temperature observed after the maximum represents the loss of heat before the maximum and for any given minute, on condition that the mean temperature of this minute does not differ more than one degree from the maximum temperature.

II. If the temperature of the given minute differs by more than one degree but less than two degrees from that of the maximum, the number that represents the law of decrease at the moment of the maximum less 0.005 will give the desired correction.

A comparison of the two methods in some twenty cases showed an average difference of 0.0013, which on one gram naphthalene would amount to about three calories, or 0.3 per cent; a difference within the limit of error in technical work.

2. *Correction for Formation of Nitric Acid.*—About fifty milligrams of nitric acid are formed from the nitrogen of the air by the combustion, and it is necessary to ascertain the amount of this and subtract the heat of formation, 227 cal. per gram, from the heat of combustion of the substance under examination. This is estimated by titration with a standard alkali solution containing 3.706 grams of sodium carbonate, Na_2CO_3 . One cubic centimeter of this solution is equal to .0044 gram nitric acid, of which the heat of formation is one calorie, so the number of cubic centimeters required to titrate the washings of the bomb can be written at once as calories. Methyl orange is used as an indicator.

3. *Correction for the Combustion of the Iron Wire.*—The combustion of the small piece of iron wire used to ignite the combustible adds to the apparent rise in temperature, and correction must be made by taking a known weight of wire and subtracting its heat of combustion. A No. 32 to 36, Brown and Sharpe gauge, is suitable, and it is preferable to use the copper-plated wire, as the plain wire easily becomes oxidized on the surface. Of No. 36 wire one meter weighs .3160 gram; of this in our experiments we used a length of 4.8 centimeters, giving a heat of combustion of 25 calories.

The heat of combustion of iron under these circumstances is stated to be 1650 cal. per gram.* This is on the assumption that all the iron is burned to Fe_3O_4 . That this is not correct is shown by the

* Berthelot: *Traité Pratique de Calorimétrie Chimique*, p. 139.

following analyses of the iron oxide resulting from some twenty combustions each: No. 1, 71.59 per cent iron in oxide; No. 2, 75.81 per cent iron in oxide. The first would correspond to 74.7 per cent Fe_3O_4 and 25.3 per cent Fe_2O_3 , while the second might be composed of 86.8 per cent Fe_3O_4 and 13.2 per cent unburned iron. Other mixtures of iron and its oxides would of course give the same analytical results. The heat of combustion of ferric oxide is not exactly known, but it is certainly less than that of Fe_3O_4 . It appears from this that the character of the oxides formed is variable and the ordinary correction consequently inaccurate by several calories. The error is not, however, as great as the analyses would seem to indicate, for it was only the larger particles such as could be easily picked off that were taken for analysis.

4. *Correction for Sulphur.*—The presence of sulphur in the combustible necessitates another correction, for the free sulphuric acid formed by the combustion of sulphur compounds will be titrated as nitric although its heat of combustion is different and the heat of the burning sulphur is a legitimate part of the heat of combustion of the fuel. The sulphuric acid must therefore be determined in the rinsings of the bomb after the titration for free acid, and the heat of formation of its equivalent in nitric acid subtracted from the number obtained by titration. The weight of barium sulphate multiplied by 100 gives directly the number of calories to be subtracted.

Sulphur, however, exists in coal in three forms: organic sulphur compounds, pyrites, and sulphates, chiefly gypsum. Of these the third at least would not be converted into free acid by the combustion, and the ordinary correction would be too great. The point is of especial importance in dealing with Wyoming coals, for, although the percentage of sulphur is generally small, yet it is more often in the form of gypsum than pyrites. Nevertheless, as to find the original state of the sulphur would require two analyses, the whole is regarded as forming sulphuric acid, and the equivalent, usually amounting to about 5 cal., has been subtracted in all cases.

DETERMINATION OF WATER VALUE OF THE APPARATUS.

The heat produced by combustion is absorbed not only by the water in the calorimeter, but also by the calorimeter vessel, the bomb, the stirring apparatus and thermometer in contact with it. But the amount of heat absorbed by them depends on their weight and material. It is therefore necessary to find the water value of the apparatus, that is, what weight of water would absorb the same amount of heat for the same rise in temperature. This is done by multiplying the weight of the different parts of the apparatus by the specific heat of the material of which they are composed.* In this case the calculation was as follows:

* The weight of the enamel on the bomb was not known. The water value of the apparatus as calculated is therefore too low.

| | |
|--|--------|
| Calorimeter vessel 445 g., stirring apparatus 143 g., 588 g. brass $\times .093$ | 54.69 |
| Bomb, 3920 g. steel $\times .1097$ | 430.03 |
| 22.36 g. platinum $\times .0324$ | .72 |
| 8 g. lead $\times .031$ | .25 |
| Thermometer, bulb 2.72 g., tube 33.56 g., $\frac{1}{4}$ immersed, 8.61 g. glass $\times .184$ | 1.58 |
| 35.36 g. mercury $\times .033$ | 1.17 |
| Oxygen, (20 atmospheres pressure) $16.7 \times .155^*$ | 2.59 |
| Water value | 491.03 |

Another method of determining the water value of a calorimeter is to burn in it certain compounds whose heat of combustion is accurately known. This has the advantage that the water value of the whole apparatus is determined directly and under the same conditions as in an ordinary combustion, but it has the disadvantage that the heat of combustion of no compound is exactly known. In determining the water value of our calorimeter we made twelve combustions with resublimed naphthalene, of which the heat of combustion as determined by Berthelot and his assistants is 9692 calories. The average of the twelve combustions gave 491.4 grams as the water value of the calorimeter. One combustion with granulated sugar, using 2 gm. and taking the heat of combustion as 3961.7 cal. per gram, gave 491 g. as the value. As all these are in satisfactory agreement, the number 491 has been adopted as the water value. A difference of one gram in water value makes a difference of about .03 per cent in the final result.

An Example.—The method of calculating the heat of combustion may be made more clear by giving in detail an example in which the corrections are unusually large.

Coal No. 33. L. R. Meyer, Carbon. November 30, 1894.
1 gram coal. .0250 g. wire. 2300 g. water in calorimeter.

| Preliminary Period. | Combustion Period. | Final Period. |
|---------------------|------------------------|---------------|
| 0—11.47° C. | 5—11.48° C. | 9—13.64° C. |
| 1—11.47 | 5 $\frac{1}{2}$ —12.50 | 10—13.63 |
| 3—11.48 | 6—13.34 | 11—13.62 |
| 4—11.48 | 7—13.63 | 12—13.62 |
| 5—11.48 Fired. | 8—13.64 | 13—13.62 |
| | 9—13.64 | 14—13.61 |

Nitric acid = 9.0 c.c. Sodium carbonate solution = 9 cal. Weight BaSO₄, .0472.

From the 9th to the 14th reading .03° heat was lost, or .006° per minute. Then for the three and a half minutes, 5 $\frac{1}{2}$ —6, 6—7, 7—8, 8—9, the total loss = .021°. The temperature rose .01° during the preliminary period, or .002° per minute. The correction for the half-minute 5—5 $\frac{1}{2}$ is therefore .001. The total rise in temperature is from 11.48°

* Specific heat at constant volume.

to 13.64° , or 2.16° ; adding to this the correction $.02^{\circ}$ gives 2.18° for the true rise due to combustion. The water value of the apparatus, 491 g., added to the weight of water used, 2300 g., gives 2791 g., which multiplied by 2.18 gives 6084.4 calories. The weight of the barium sulphate with the decimal point moved two places to the right gives 4.7 to be subtracted from 9.0 cal., leaving 4.3 cal. The weight of the wire, .0250 g., multiplied by 1650 gives 41.2 cal. The sum of the corrections for formation of iron oxide and nitric acid, 45.5, subtracted from 6084.4 gives 6039 calories for the true heat of the combustion of one gram of the coal. The use of Regnault's formula in this case would make the rise of temperature 2.179° and the heat of combustion 6036 cal.

NOTES ON CALORIMETRY.

The use of a cylinder of oxygen under great pressure, such as is now in the market, dispenses with a compression-pump, and shortens the time required for a combustion by one-half. It has the disadvantage that the quality of the oxygen is not as much under control as where it is made in the laboratory.

It is not necessary that the coal should be finely powdered, nor is there any difficulty in using fine samples. Of the samples used, one was in coarse fragments and some had been passed through a hundred-mesh sieve. In using very fine coal or freshly sublimed naphthalene, it is convenient to compress it into tablets with a "diamond mortar" such as is used in crushing minerals for analysis.

The cylinder of the compression-pump must be kept cool by a water-jacket, or the oil will become ignited by the compressed oxygen and an explosion result.

The rapidity with which the heat is given up to the water of the calorimeter is shown by the following average of ten determinations:

| | | |
|----------------------------------|-------------|----------|
| Heat given off during the period | 5-5½ = 27.9 | per cent |
| " " " " " " | 5½-6 = 50.3 | " " |
| " " " " " " | 6-7 = 20.1 | " " |
| " " " " " " | 7-8 = 1.7 | " " |
| | 100.0 | |

That is, 78.2 per cent of the total heat is absorbed by the water during the first minute and 98.3 per cent during the first two minutes.

Care must be taken to scrape off the iron oxide from the electrodes before attaching the new wire, as a very thin film will prevent ignition by the electric current.

Lord and Haas's Tests of American Coals.—In 1897 Professors N. W. Lord and F. Haas, of the Ohio State University, Columbus, O., presented a paper to the American Institute of Mining Engineers (Trans., vol. xxvii. p. 259) giving the results of proximate and ultimate analyses and determinations of calorific value, by means of

the Mahler calorimeter, of forty different samples of coal, selected from seven different mining regions. Prof. Lord also published a paper in *Engineering News* of Feb. 16, 1899, giving the results of similar tests of five samples of coal from different parts of Jackson Co., Ohio. The figures obtained in both series of tests are given in the table on pages 104 and 105. The figures in the last two columns have been calculated by the author, to show the heating value and the per cent of fixed carbon of the combustible, which were not given in the original papers. The ultimate analyses as reported include the hydrogen and oxygen of the moisture, together with that of the dry coal, and the figures for "average, dry coal," have been computed by the author in order to make the analyses comparable with analyses of other coals.

These tests are by far the most complete that have up to this time been made of American coals. The extreme accuracy of the work is shown by the close agreement of the results with those obtained by Mahler with foreign coals of similar composition, as well as by the correspondence of the calorimetric determinations with the heating value as calculated by the Dulong formula. The student is referred to the original paper for a detailed statement of the precautions taken to insure accurate work with the calorimeter.

The following is quoted from the paper:

"The probable error of a single calorimeter determination from the mean result of a large number was computed from all the results on 21 samples of coal, on each of which more than one determination was made. There were 50 separate results on the 21 samples. Computing the error by the ordinary formula gave plus or minus 20 units, or about 0.3 of 1 per cent as the probable error of one determination. These results were obtained by different observers and at considerable intervals of time, and include slight possible variations in the condition of the sample as to moisture and oxidation. Duplicate results obtained at the same time by the same observer frequently gave much closer checks.

"The chemical analyses were made by the ordinary methods—combustion with oxygen in a glass tube containing copper oxide and lead chromate for the ultimate analyses, while the proximate analyses were made by the methods used for all the samples analyzed in this laboratory for the Ohio Geological Survey. In outline the treatment was as follows:

"One gram of the coal was dried at 100° to 105° C. for one hour in a crucible, the loss being called moisture. After drying, the same portion was heated 3½ minutes over a Bunsen burner, then 3½ minutes over a blast-lamp, and the loss was called volatile combustible. The

crucible was tightly covered and not allowed to cool during the change from burner to blast-lamp.

“The results of the work are given in the following tables, in which the coals of each seam are grouped together. In addition to the analytical and calorimetric data the following figures are tabulated:

“1. The calorimetric power, computed from Dulong’s formula, in this form:

$$\text{Cal. power} = 8080C + 34,462 (H - \frac{1}{8}O) + 2250S,$$

C, H, O, and S being the amounts of carbon, hydrogen, oxygen, and sulphur in one unit of the coal.

“2. The difference between this result and the bomb determination, expressed in percentages.

“On examining the accompanying table of results, the following points appear:

“In the first place, the remarkable coincidence between the heating powers, as calculated from Dulong’s formula, and the experimental determinations. In the case of the averages of the different seams we find practical identity between the heating power as calculated from the formula based simply on the heat developed by the combustible elements, and the results of the calorimeter. This is so much at variance with the claims of many writers that, were it not the result of so many determinations, it might pass as a mere accident. The maximum difference between the heat calculated from the elementary analysis and the heat developed in the bomb is 2 per cent of the total calculated heat, the minimum difference 0.1 per cent. The possible error of an ultimate analysis may be placed at 0.5 per cent on carbon and 0.2 per cent on hydrogen, especially with coals as high in ash and sulphur as are many of the samples included in our tests. This would lead to an error of about 108 units, or nearly 1.4 per cent on the calculated heat value. While, of course, the probable error of the ultimate analysis is less than this, it seems certainly possible that the differences between the observed and calculated heat values are within the limits of experiment.

“The ultimate analysis of coals is vastly more difficult to make than the calorimeter determination; and therefore it is extremely important to know how far the ordinary proximate analysis so universally used in this country, and so rapidly made, can serve as a guide in rating the calorific powers of coals.

“A relation between the fixed carbon and the calorimetric test was stated by Mr. Kent (“Heating Value of Coal,” “Mineral Industry,” 1892, p. 97); but the results of our work do not appear to correspond to his figures. Taking the Pittsburgh coal, we find the average calorific power of the samples observed to be 7532. The average ash is

8.02, the average moisture 1.37. Calculating from this the calorific power of the coal free from ash and moisture, we find it to be 8313. The average fixed carbon is 53.95, and this, calculated ash- and moisture-free, gives 59.54. Interpolating from Kent's table, this would give 8054 as the calorific power, a difference of 259 units, or 3.2 per cent. The same calculation on the average Freeport coal shows a difference of 296 units, or nearly 4 per cent.

"The determination of fixed carbon is very uncertain, being much influenced by slight changes in method; therefore it is entirely possible that these differences are due to our method of analysis, giving low results as compared with that used by the chemists furnishing his figures. . . .

"Our determinations of fixed carbon could not be used for estimating the calorific power within any satisfactory limit of accuracy.

"Attempts to derive a general law for all the coals examined were abandoned, and the question was taken up, how far the coal of a given deposit or seam can be regarded as of uniform quality, and its specific character determined. This has led to the interesting results given in the tables. Taking the coals of the same seam, we averaged the results of the calorimeter, and, reducing by the average ash and moisture, soon found that comparable results were obtained by regarding this value as a constant for the seam over the area examined."

"The results of our tests seem to indicate the interesting conclusion that the character of a coal-seam, as far as its fuel value is concerned, is a nearly constant quantity over considerable areas. The determination of the value for seams would be of great use, as the rapid proximate analysis, or, for that matter, merely the determination of ash and moisture, in low-sulphur coals, would be sufficient to grade coals of the same vein. Of course it is dangerous to argue from so few examples; but the proposition seems reasonable. At least, we hope that further work may confirm these conclusions.

Prof. Lord says concerning the Jackson Co., Ohio, coals:

"The failure of the last two samples to show close correspondence between the calculated values by Dulong's formula and the calorimetric results is contrary to our experience with other coals. These last two analyses are the average of duplicates, which do not agree very satisfactorily, and therefore the results are open to question, as I fear some carbon may have escaped combustion. The other analyses are the averages of very closely agreeing duplicates. If the conclusion as to the comparative constancy of the heating value of the combustible in any given seam is correct, then the determination of the heating power of any particular sample from the seam becomes a simple matter, if the ash, sulphur, and moisture in the sample be known, and the seam constant for the kind of fuel be known."

The following extracts are taken from a discussion of Lord and Haas's paper by the author (Trans. A. I. M. E., vol. xxvii. p. 946):

The conclusion of the authors that the actual coal (moisture and ash excluded) of a given seam over considerable areas may be regarded as of uniform heating value, is one of great practical importance. Should this conclusion be established, or its limitations defined, by future tests, it will be possible for us to approximate closely the heating value of any given sample of coal by ascertaining where it is mined and by determining its moisture, sulphur, and ash, which are the three variable elements in lots of coal from the same mine, without going to the expense of an ultimate analysis or a calorimeter test. In any given mine or seam the sulphur, averaged from car-load lots, is reasonably constant, especially in such coals as are of good repute in the market as steam-coals. The moisture and ash, however, are subject to accidental variations, but they are easily determined.

I have discovered, in the analyses given in the paper, an interesting relation between the percentage of carbon as found by the ultimate analysis and the percentage of fixed carbon as found by the proximate analysis. It is, that in the bituminous coals the fixed carbon is nearly equal to the total carbon minus five times the available hydrogen ($H - \frac{1}{8}O$), and that in the semi-bituminous coal (Pocahontas) it is nearly equal to the total carbon minus three times the available hydrogen. The following is the calculation from the average analysis:

| | Avail- able H. | Total C. | Differ- ence. | Fixed Carbon. | Differ- ence. |
|--------------------|-------------------------|----------|------------------|------------------|------------------|
| Pocahontas..... | $3.89 \times 3 = 11.67$ | 84.87 | 73.20 | 74.84 | + 1.64 |
| Thacker.... | $4.27 \times 5 = 21.35$ | 78.65 | 57.30 | 56.67 | - .63 |
| Pittsburgh..... | $4.15 \times 5 = 20.75$ | 75.24 | 54.49 | 53.81 | - .68 |
| Darlington..... | $4.01 \times 5 = 20.05$ | 75.19 | 55.14 | 54.69 | - .45 |
| Mahoning..... | $3.71 \times 5 = 18.55$ | 71.13 | 52.58 | 50.95 | - 1.63 |
| Upper Freeport ... | $3.94 \times 5 = 19.70$ | 72.65 | 52.95 | 51.63 | - 1.32 |
| Jackson..... | $3.22 \times 5 = 16.10$ | 70.72 | 54.62 | 52.78 | - 1.84 |
| Hocking Valley.... | $3.34 \times 5 = 16.70$ | 68.03 | 51.33 | 49.64 | - 1.69 |

These figures indicate that in the bituminous coals the volatile hydrocarbon (excluding H_2O) is equivalent to $2C_2H_4 + CH_4$, or to 5 parts C and 1 part H; and that in the semi-bituminous coals the volatile hydrocarbon is equivalent to CH_4 , or 3 parts C and 1 part H. If these relations should be confirmed by other coal analyses, they may be useful as a criterion of the accuracy of the proximate analysis. Also having the ultimate analysis of a coal, and knowing its class, as bituminous or semi-bituminous, the proximate analysis may be calculated therefrom with slight probability of error.

I quote the following extracts from the paper:

"A relation between the fixed carbon and the calorimetric test was stated by Mr. Kent ('Heating Value of Coal,' Min. Ind., 1892, p. 97); but the results of our work do not appear to correspond to his figures. . . . Our determinations of fixed carbon could not be used

for estimating the calorific power within any satisfactory limit of accuracy."

These statements of the authors refer to the curve which I plotted from Mahler's tests of European coals, published in my article in vol. i. of "Mineral Industry," and to the table which I derived therefrom.

The value of my curve and table for use in connection with American coals having been thus called in question, I have been led to study the subject anew, with the view of comparing the work of the authors with that of Mahler and of learning whether or not there was any essential difference between the American and European coals, and whether a curve plotted from tests of the latter would be of any value when applied to the former.

In Fig. 7 I have plotted a portion of the curve derived from the results of Mahler between the limits of 55 and 63 per cent of fixed carbon, together with the results obtained by Lord and Haas on coals lying

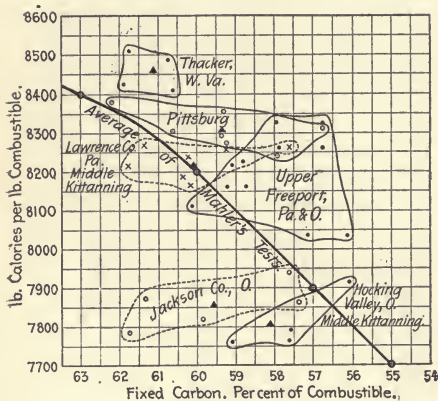

FIG. 7.—RELATION OF HEATING VALUE TO PER CENT OF FIXED CARBON. (Tests of Profs. Lord and Haas.)

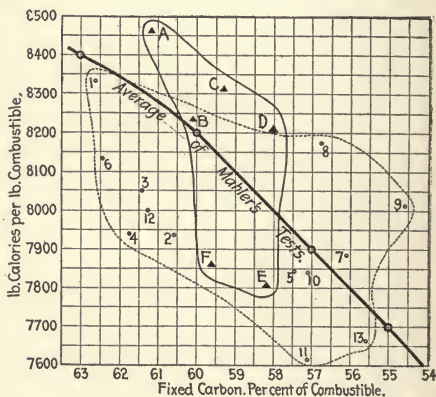

FIG. 8.—RELATION OF HEATING VALUE TO PER CENT OF FIXED CARBON.

(Lettered points are averages of Lord and Haas's tests. Numbered points are tests by C. W. Houghton.)

within the same limits. The dots and crosses represent the individual tests, and the small black triangles the average figures for each class of coal. Each class of coal is surrounded by a boundary line showing the extent of variation, or what I call the "field" of each coal.

In Fig. 8 the same portion of the Mahler curve is given, with the average results of Lord and Haas, together with the results of calorimeter tests of thirteen different varieties of coal, which were made for me last year by Mr. C. W. Houghton, M.E., assistant in Sibley College, Cornell University, using the calorimeter of Prof. R. C. Carpenter, which is described in the Transactions of the American Society of Mechanical Engineers, vol. xvi., p. 1040. The results of these tests were as follows:

| | Coal Dry and Free from Ash. | |
|---------------------------|-----------------------------|----------------|
| | Fixed Carbon. | Heating Value. |
| | Per cent. | Calories. |
| 1. Youghiogheny, Pa..... | 62.6 | 8330 |
| 2. Pittsburgh, Pa..... | 60.6 | 7890 |
| 3. Vanderpool, Ky..... | 61.5 | 8000 |
| 4. Brier Hill, O..... | 61.8 | 7890 |
| 5. Hocking Valley, O..... | 57.5 | 7830 |
| 6. Big Muddy, Ill..... | 62.5 | 8080 |
| 7. Streator, Ill..... | 56.2 | 7890 |
| 8. Ladd, Ill..... | 56.8 | 8170 |
| 9. Seatonville, Ill..... | 54.7 | 8060 |
| 10. Wilmington, Ill..... | 57.1 | 7840 |
| 11. Mt. Olive, Ill..... | 57.1 | 7610 |
| 12. Indiana block..... | 61.4 | 7950 |
| 13. Indiana lump..... | 55.6 | 7670 |

The figure for Streator coal is the average of five tests of samples from as many different car loads, the range being from 7780 to 8000 calories. The figure for Big Muddy is the average of two lots, which varied 170 calories; and that from Wilmington is the average of two lots which varied 80 calories. The other tests were of only one sample each.

The plotting of these tests shows that they cover quite a wide field, and tends to confirm the conclusion of the authors that the heating power has no definite relation to the fixed carbon; but it will be observed that the general trend of the field of Houghton's tests is in the direction of the Mahler line; that the maximum deviation of any single test from the Mahler line is less than 500 calories, or about 6 per cent; and that Houghton's tests arrange themselves about equally on each side of the Mahler line. These tests were simply commercial ones, made to check the results of boiler tests. I am inclined to believe that the figures of heating value are much more reliable than those of the percentages of fixed carbon, for the latter, as is said by Profs. Lord and Haas, is not easy to determine with accuracy.

Fig. 7 is especially interesting in showing that each of the six classes of coals tested by the authors of the paper, within the limits of 55 and 62 per cent of fixed carbon, has a law of its own. Four of these classes, the Pittsburgh, the Lawrence Co., Pa., the Jackson, and the Hocking Valley, O., seem to have a very uniform heating power through a wide range of variation in percentage of fixed carbon. The same might be said of the Upper Freeport coal, if the two tests which give less than 8100 calories were omitted. The four samples of Thacker, W. Va., coal are very close together, both in heating power and in percentage of fixed carbon.

In Fig. 9 are plotted all of Mahler's results between the limits of 47 and 97 per cent of fixed carbon. A boundary line is run around all the tests, and the average curve given in the paper in "Mineral

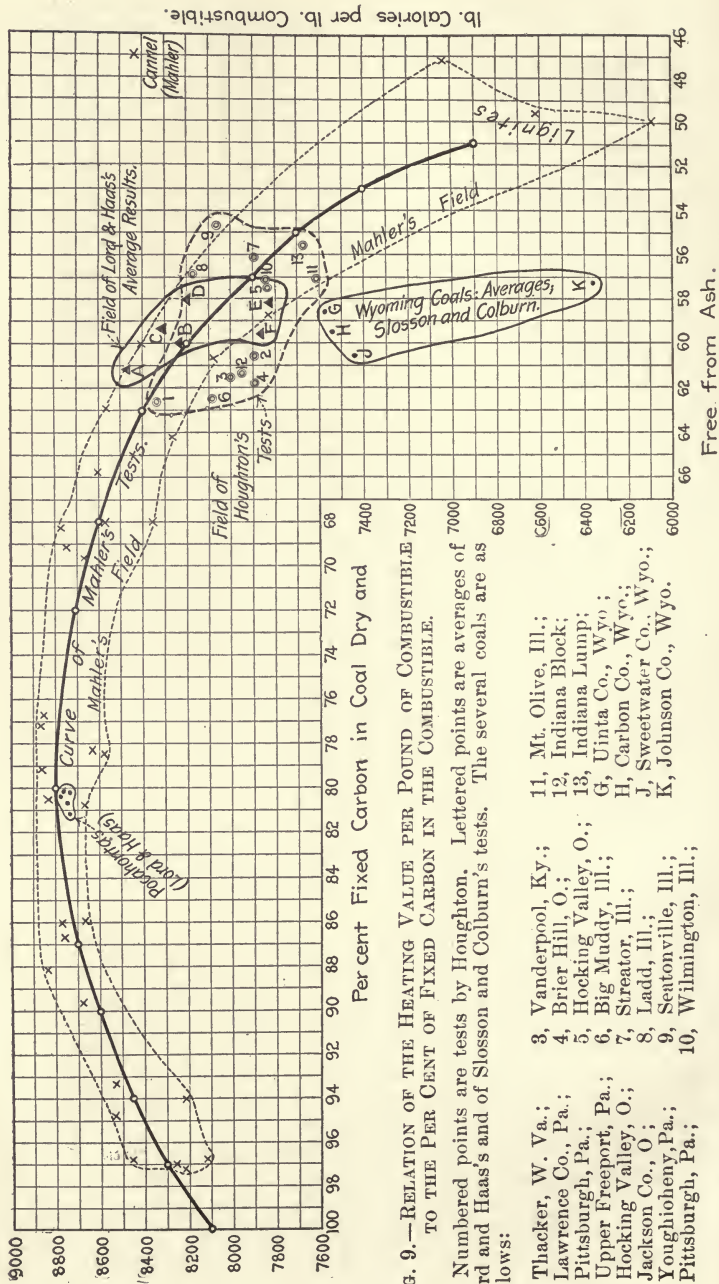

Fig. 9.—RELATION OF THE HEATING VALUE PER POUND OF COMBUSTIBLE 7200 TO THE PER CENT OF FIXED CARBON IN THE COMBUSTIBLE.

Numbered points are tests by Houghton. Lettered points are averages of 7000 Lord and Haas's and of Slosson and Colburn's tests. The several coals are as follows:

- A, Thacker, W. Va.;
- B, Lawrence Co., Pa.;
- C, Pittsburgh, Pa.;
- D, Upper Freeport, Pa.;
- E, Hocking Valley, O.;
- F, Jackson Co., O.;
- G, Younghiogeny, Pa.;
- H, Ladd, Ill.;
- I, Seatonville, Ill.;
- J, Sweetwater Co., Wyo.;
- K, Johnson Co., Wyo.;
- 1, Pittsburgh, Pa.;
- 2, Wilmington, Ill.;
- 3, Vanderpool, Ky.;
- 4, Brier Hill, O.;
- 5, Hocking Valley, O.;
- 6, Big Muddy, Ill.;
- 7, Streator, Ill.;
- 8, Ladd, Ill.;
- 9, Seatonville, Ill.;
- 10, Wilmington, Ill.;
- 11, Mt. Olive, Ill.;
- 12, Indiana Block.;
- 13, Indiana Lump.;
- G, Uinta Co., Wyo.;
- H, Carbon Co., Wyo.;
- J, Sweetwater Co., Wyo.;
- K, Johnson Co., Wyo.;

Free from Ash.

Industry," is reproduced.* Comparing the curve with the plottings of the individual tests and with the boundary enclosing them, it will be seen that they justify the conclusion stated in that paper, viz., that, "knowing the percentage of fixed carbon in the dry coal free from ash, we may, in the case of all coals containing over 58 per cent of fixed carbon, predict their heating value within a limit of error of about 3 per cent."

Fig. 9 shows also that the figures for Pocahontas coal obtained by Lord and Haas all come remarkably close to the Mahler line, all five tests lying entirely within the Mahler field. The average figure from these tests, 8751 calories, is only 49 calories, or less than 0.6 per cent, lower than the figures in my table for 80 per cent of fixed carbon.

Another thing shown by Fig. 9 is, that Lord and Haas's tests cover only a small portion of the range of composition of the coals tested by Mahler. Mahler's tests, excluding the lignites, cover the entire range between 58 and 97 per cent of fixed carbon, while Lord and Haas's are confined between 55.7 and 62.2 per cent, except the five tests of Pocahontas coal, which are between 80.1 and 81.2 per cent.

With the three diagrams, Figs. 7, 8, and 9, we may find what is the probable error of the conclusion that I drew in 1892 from the study of Mahler's work, viz., that "knowing the percentage of fixed carbon in the dry coal free from ash, we may in the case of all coal containing over 58 per cent of fixed carbon predict their heating value within a limit of error of about 3 per cent." Excluding the coals that have below 58 per cent of fixed carbon in the combustible, the variation of any one of Lord and Haas's coals from the Mahler line does not exceed 320 calories, or 4 per cent. Taking the average figure for each class of coals, it falls in all cases within the limit of 3 per cent.† The figures from Houghton's tests also fall within the limit of 4 per cent variation from the Mahler line, except coal No. 4, Brier Hill, O. (of which only one test was made), which falls 400 calories, or nearly 5 per cent, below the Mahler line.

On the whole, therefore, I consider that both Lord and Haas's and Houghton's tests are a substantial confirmation of the conclusion I drew from Mahler's tests. Taking into consideration the fact that the reported percentage of fixed carbon is very apt to be 2 or 3 per cent in error, I am disposed to hold to my original conclusion, at least until a larger series of tests may show that it should be modified.

* The curve is plotted from the figures given in the table on page 48. The average results from coals of four counties in Wyoming, by Slosson and Colburn, have been added to the diagram.

† This was written before the tests of the Jackson Co. coals were published. Two out of the five samples gave exceptionally low calorimetric values as related to their fixed carbon percentage, one of them being 6 per cent below the Mahler line, and the average of the Jackson Co. coals is thus 4 per cent below the line. The Wyoming coals, now included for the first time in the diagram lie entirely outside of the Mahler field and appear to belong to an entirely different class from any of the Eastern coals.

It is to be observed, however, that the Mahler line falls rapidly with percentages below 62 per cent of fixed carbon; and it is therefore to be expected that below this point there will be a greater range of variation in heating value than above it. When the volatile matter exceeds 38 per cent, an increasing proportion of it is oxygen, and the relative proportion of oxygen in the highly volatile coal varies in the coals of different districts, as is shown by Lord and Haas's analyses. Thus the Upper Freeport coal averages only 9.58 per cent of O (in the coal dry and free from ash), while the Hocking Valley coal averages 16.10 per cent, although both coals have the same percentage of fixed carbon, viz., 58 per cent. Full credence, therefore, is to be given to the conclusions drawn from Lord and Haas's tests, that, when the fixed carbon is less than 62 per cent of the combustible, each class of coal has a law of its own, and coals of any one class may differ in heating power from the coals of another class containing the same percentage of fixed carbon to an extent as great as 5 per cent—as in the case with the Upper Freeport and the Hocking Valley coals.*

Heating Value of Wyoming Coals.—The following table is condensed from a report by Professors E. E. Slosson and L. C. Colburn of the University of Wyoming, Laramie, Wyo. (Special Bulletin, Jan., 1895.)

| | Coal. | | | | | | Combustible. | | |
|---------------------|--------|------------------|---------------|------|----------|-----------|---------------|-----------|------------------|
| | Water. | Volatile Matter. | Fixed Carbon. | Ash. | Sulphur. | Calories. | Fixed Carbon. | Calories. | B. T. U. per lb. |
| Uinta Co. | 2.95 | 38.00 | 54.00 | 4.95 | | 7467 | 58.70 | 8116 | 14,609 |
| “ “ | 8.82 | 33.55 | 51.75 | 5.90 | | 6017 | 60.67 | 7055 | 12,699 |
| Av. of 8 | 5.80 | 36.16 | 51.78 | 6.26 | 0.60 | 6673 | 58.39 | 7573 | 13,631 |
| Carbon Co. | 4.87 | 35.68 | 55.15 | 4.30 | .77 | 7140 | 60.72 | 7863 | 14,153 |
| “ “ | 13.65 | 39.25 | 42.60 | 4.50 | .80 | 5375 | 52.05 | 6567 | 11,821 |
| Av. of 7 | 7.83 | 35.32 | 52.15 | 4.55 | .71 | 6565 | 59.63 | 7540 | 13,572 |
| Sweetwater Co. | 5.55 | 36.95 | 55.70 | 1.80 | .86 | 7358 | 60.12 | 7942 | 14,296 |
| “ “ | 14.23 | 37.48 | 46.07 | 2.22 | .44 | 5949 | 55.14 | 7120 | 12,816 |
| Av. of 13 | 8.65 | 34.86 | 53.69 | 2.71 | .75 | 6598 | 60.63 | 7432 | 13,378 |
| Johnson Co. | 13.55 | 35.05 | 45.30 | 6.10 | | 5293 | 56.38 | 6587 | 11,857 |
| 3 samples | 14.70 | 34.30 | 44.20 | 6.80 | .34 | 4966 | 56.31 | 6326 | 11,387 |
| | 14.50 | 33.35 | 44.30 | 7.85 | .42 | 4931 | 57.13 | 6350 | 11,450 |

* The average heating value of the Jackson Co., Ohio, coals is about $5\frac{1}{2}$ per cent lower than that of the Pittsburg coals, both having about the same percentage of fixed carbon in the combustible. The lowest average value for the Wyoming coals (Johnson Co.) 6431 calories, is nearly 12 per cent below the average of the Upper Freeport (Ohio and Pa.) coals, and the difference between the heating value of the Johnson Co. and the Uinta Co., Wyoming, coals is over 15 per cent of the

The figures in the last three columns have been calculated by the author. The figures in the first two lines for each of the three counties first named are selected so as to show respectively the coals of the highest and the lowest heating value per pound of combustible of the samples tested. They show quite a large range of variation within the limits of a county. The heating value per pound combustible apparently bears no definite relation to the percentage of fixed carbon in the combustible, indicating that the quality of the volatile matter is variable. Coals from Weston, Natrona, Albany, Fremont, Sheridan, Crook, and Converse counties are within the range of quality of the coals given in the table.

The Mahler calorimeter was used in determining the heating values.

The Calorific Power of Weathered Coals.—Messrs. R. S. Hale and Henry J. Williams of Boston, in *Trans. Am. Soc. M. E.*, vol. xx., 1898, p. 333, give the results of analyses and calorimetric tests (by Mr. Williams's bomb calorimeter) of several coals which had been exposed to the weather for eleven months, and of duplicate samples of the same coals which had been sealed in glass jars. The results are condensed in the table on page 114. The following notes are extracted from the paper:

For tests of fine coal the samples were ground in a coffee-grinder, and thoroughly mixed and divided into two parts. For tests of lump coal the coals were broken into lumps of about nut size, and alternate lumps taken from the pile to form two samples. Where tests of both fine and lump coal were to be made, one sample was tightly sealed in an ordinary pint fruit jar, while the corresponding sample was exposed on an uncovered balcony out of doors for eleven months in an uncovered tin can provided with a diaphragm or bottom of fine wire gauze.

Rain and snow fell upon the coal, but the wire diaphragm permitted the water to drain off, while a paper disk placed upon the wire gauze prevented the coal from sifting through the meshes.

The lump samples were exposed in pans of much larger size, which were provided with holes to let the water drain off.

At the end of eleven months all the samples were analyzed by Mr. Henry J. Williams, together with a sample of Pocahontas coal that had been exposed in a coal-yard for three years, and one of Cumberland coal that had been under cover for three years.

In these analyses the percentages of ash in some of the exposed samples are unfortunately too high, for a little gravel was accidentally washed off the roof of the house, by the rain, into some of the cans.

higher value, 7573 calories. The Wyoming coals have therefore a far greater range of variability than any of the other coals which have been considered above.

This, however, in no way affects the relative percentages of combustible matter free from ash.

The British thermal units are calculated from the analyses by the formula: $146C + 620(H - \frac{1}{8}O) + 40S$.

The average of the results obtained shows that weathering, under the conditions described, decreases the percentage of carbon, hydrogen, nitrogen; increases the percentage of oxygen, and does not materially alter the percentage of sulphur.

ANALYSES AND HEATING VALUES OF WEATHERED AND UNWEATHERED COALS.

| Reference Letter. | Coal, Prox. Anal. | | Ultimate Analysis of Combustible. | | | | | Combustible. | | | |
|-------------------|-------------------|-------|-----------------------------------|-----------|---------|-----------|-------------------|---------------------------------------|----------------------------------|--------------------------------------|----------------------------|
| | Moisture. | Ash. | Carbon. | Hydrogen. | Oxygen. | Nitrogen. | Volatile Sulphur. | Fixed Carbon, percent of Combustible. | Heating value Calculated, B.T.U. | Heating value by Calorimeter, B.T.U. | Loss by Weathering, B.T.U. |
| B | 1.61 | 11.74 | 78.94 | 5.56 | 9.55 | 1.52 | 4.43 | 56.5 | 14,406 | | |
| Ax | 1.91 | 12.61 | 79.59 | 4.89 | 9.75 | 1.54 | 4.23 | 56.9 | 14,065 | | 341 |
| C | 1.21 | 8.69 | 83.54 | 5.69 | 5.87 | 1.63 | 3.27 | 63.6 | 15,463 | 15,461 | |
| Dx | 1.07 | 9.15 | 82.55 | 5.24 | 7.94 | 1.64 | 2.62 | 67.0 | 14,792 | 15,301 | 611† |
| P | 1.36 | 8.97 | 81.24 | 5.90 | 8.16 | 1.79 | 2.91 | 58.0 | 15,003 | | |
| Ex | 0.89 | 10.02 | 81.56 | 5.67 | 8.14 | 1.69 | 2.94 | 57.8 | 14,408 | | 95 |
| R | 1.07 | 8.77 | 82.47 | 6.01 | 6.81 | 1.88 | 2.83 | 56.5 | 15,353 | | |
| Sx | 1.39 | 8.50 | 82.15 | 5.95 | 7.10 | 1.62 | 3.17 | 57.5 | 15,260 | | 93 |
| I | 0.53 | 4.34 | 88.72 | 5.22 | 3.79 | 1.74 | 0.53 | 77.2 | 15,913 | | |
| Hx | 1.12 | 6.32 | 88.05 | 5.04 | 4.08 | 1.78 | 1.04 | 75.8 | 15,705 | | } 208 gain |
| K | 2.02 | 10.08 | 81.45 | 5.62 | 10.19 | 1.66 | 1.09 | 61.2 | 14,622 | | |
| Jx | 1.46 | 11.06 | 81.33 | 5.67 | 9.88 | 1.67 | 1.45 | 60.4 | 14,685 | | 63 |
| O | 1.77 | 8.44 | 83.50 | 5.67 | 7.13 | 1.79 | 1.90 | 58.5 | 15,231 | 15,246 | |
| Nx | 1.71 | 10.47 | 82.41 | 5.74 | 8.39 | 1.67 | 1.79 | 61.4 | 15,011 | 15,200 | 220† |
| L | 0.95 | 5.75 | 88.85 | 5.19 | 3.03 | 2.07 | 0.87 | 78.2 | 15,989 | 16,048 | |
| Mx | 0.70 | 7.77 | 88.38 | 4.77 | 4.35 | 1.60 | 0.89 | 80.6 | 15,562 | 15,958 | 427† |
| G* | 0.79 | 7.51 | 88.90 | 4.82 | 2.87 | 2.04 | 1.37 | 80.0 | 15,799 | | |
| Po† | 0.94 | 7.06 | 91.15 | 4.75 | 2.15 | 1.28 | 0.68 | 80.6 | 16,113 | | |

* Indoors three years.

† Exposed in a coal-yard three years.

‡ 611, 230, and 427, loss in calculated values. 160, 40, and 90, corresponding loss by calorimeter tests.

Reference letters: B, C, etc., unweathered coals; Ax, Dx, etc., weathered coals; B, A, C, D, Yorkville lump, Portland, Ohio; P, E, Pittsburg, Pa., fine; R, S, do., lump; I, H, New River, W. Va., fine; K, J, Nickel Plate, fine, McDonald, Pa.; O, N, do., lump; L, M, G, Georges Creek, Cumberland, Md., fine; Po, Pocahontas, Va., fine.

The conclusions to be drawn from an examination of the results shown are:

1st. That weathering decreases by about two per cent the theoretical calorific power, as calculated by Dulong's formula.

2d. That weathering decreases by about one half of one per cent the actual or true calorific power, as shown by the three results obtained with the bomb.

The results obtained by Messrs. Hale and Williams are plotted on the diagram given below, with relation to the fixed carbon in the combustible, together with the curve obtained from Mahler's tests. The diagram shows that all the coals containing over 59% fixed carbon are within 3% of the corresponding position in

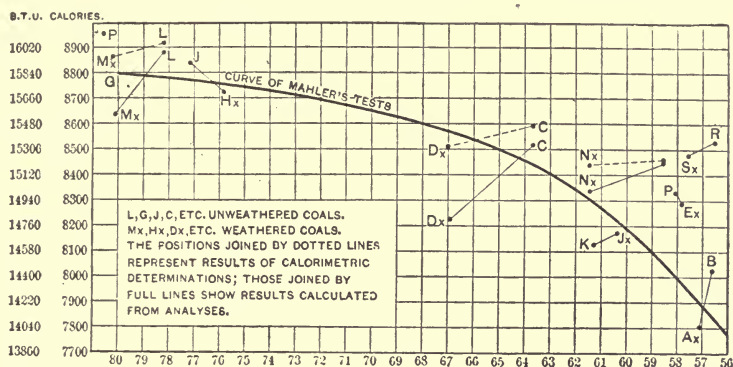

FIG. 10.—HEATING VALUE OF WEATHERED AND UNWEATHERED COALS.

the curve, with the exception of the result calculated from the ultimate analysis of the weathered coal D. The exception is apparently due to an error in the analysis. The proximate analysis of this coal shows an increase in the fixed carbon by weathering of 3.68%, referred to combustible, while the ultimate analysis shows a decrease in the total carbon of 0.99%. These figures appear incompatible.

The coals containing less than 59% fixed carbon show, in most cases, a wide divergence from the curve, tending to confirm the conclusion drawn from the work of Lord and Haas, that among the highly volatile coals each class of coal has a law of its own.

Coals AB and CD, both said to be Portland lump, from Yorkville, Ohio, show such a great difference in percentage of fixed carbon and in heating value that they appear to belong to entirely different classes of coal. It would be interesting to know whether these samples came from the same seam or from different seams. If from the same seam, the figures would indicate that the conclusion of Professors Lord and Haas, that the coals mined from one seam over a considerable area of country have a nearly uniform heating value, has some exceptions.

It should be noted that the loss in heating value per pound of the combustible portion of the coal may not be a true measure of the actual loss in heating value of the whole of a given lot of coal, for besides the loss in heating value per pound there may be also a loss in weight, and this, if any, expressed as a percentage, should be added to the

loss in heating value per pound. On the other hand, there may be a gain in weight due to oxidation. In most of these samples the oxygen seems to have increased.

Weathering of Coal.—The practical effect of the weathering of coal, while sometimes increasing its absolute weight, is to diminish the quantity of carbon and disposable hydrogen and to increase the quantity of oxygen and of indisposable hydrogen. Hence a reduction in the calorific value.

An excess of pyrites in coal tends to produce rapid oxidation and mechanical disintegration of the mass, with development of heat, loss of coking power, and spontaneous ignition.

The only appreciable results of the weathering of anthracite within the ordinary limits of exposure of stocked coal are confined to the oxidation of its accessory pyrites. In coking coals, however, weathering reduces and finally destroys the coking power, while the pyrites are converted from the state of bisulphide into comparatively innocuous sulphates.

Richters found that at a temperature of 158° to 180° Fahr., three coals lost in fourteen days an average of 3.6% of calorific power.

It appears from the experiments of Richters and Reder that when there is no rise in the temperature of coal piled in heaps and left exposed to the air during nine to twelve months, it undergoes no sensible change in any respect; and that, on the other hand, when the coal becomes heated, it suffers precisely the same kind of change that was found by Richters to be effected in coal by heating it in contact with atmospheric air to a comparatively low temperature, namely loss of carbon and hydrogen by oxidation and increase of the absolute weight of the coal owing to the fixation of oxygen.*

Composition and Heating Values of German Coals.—The table on pages 117 and 119 is abstracted from a paper by H. Bunte and P. Eitner, in "Zeitschrift des Vereines Deutscher Ingenieure," May 26, 1900. In the original the heating values, as determined by the Mahler calorimeter and as calculated from the ultimate analysis, are reduced by a "correction" for the latent heat of evaporation of water. The formula used in the calculation from the analysis was $81C + 250(H - \frac{1}{8}O) + 25S - 6W$, in which C, H, O, S, and W are respectively the percent-

* Reports of 2d Geological Survey of Pennsylvania, vol. M.M., p. 113; also Percy's "Metallurgy: Refractory Materials and Fuel," 1873. See also papers by R. P. Rothwell, Trans. A. I. M. E., vol: iv. p. 55, and by I. P. Kimball, Trans. A. I. M. E., vol. viii. p. 204.

ANALYSES AND HEATING VALUES OF GERMAN COALS—BUNTE.

| | Air-dried Coal. | | | | Fixed Carbon—Per cent Combustible. | Combustible. | | | | Calculated Heating Value of Combustible. | |
|--|-----------------|------------------|--------|-------|------------------------------------|--------------|------|-------|------|--|----------------|
| | Fixed Carbon. | Volatile Matter. | Water. | Ash. | | C | H | O+N | S | Calories. | B.T.U. per lb. |
| | | | | | | | | | | | |
| <i>Ruhr Coals.</i> | | | | | | | | | | | |
| 1. Bickefeld | 81.99 | 13.23 | 0.80 | 3.98 | 86.1 | 89.93 | 4.24 | 3.74 | 2.09 | 8,661 | 15,626 |
| 2. Bonifacius | 75.67 | 16.64 | 1.09 | 6.60 | 82.0 | 86.23 | 4.59 | 7.37 | 1.50 | 8,324 | 14,983 |
| 3. Consolidation | 70.04 | 23.71 | 1.14 | 5.11 | 74.7 | 87.37 | 5.17 | 6.53 | 1.03 | 8,642 | 15,556 |
| 4. Dahlbusch | 56.11 | 24.83 | 2.07 | 16.99 | 69.3 | 85.85 | 5.23 | 7.87 | 1.05 | 8,489 | 15,280 |
| 5. Dannenbaum | 73.97 | 21.04 | 1.84 | 3.15 | 77.8 | 89.65 | 4.62 | 4.62 | 1.11 | 8,730 | 15,714 |
| 6. Ewald | | | | 2.18 | 2.43 | | | 10.86 | 0.66 | 8,182 | 14,728 |
| 7. Friedrich Ernestine | 65.12 | 28.98 | 1.54 | 4.96 | 69.5 | 86.19 | 5.28 | 7.33 | 1.20 | 8,582 | 15,448 |
| 8. Fröhliche Morgensonne | 83.55 | 14.12 | 0.70 | 1.63 | 85.5 | 91.40 | 4.51 | 2.81 | 1.28 | 8,914 | 16,045 |
| 9. General | 66.92 | 28.04 | 1.42 | 3.62 | 70.5 | 86.31 | 5.07 | 6.97 | 1.65 | 8,523 | 15,341 |
| 10. Graf Boust | 71.14 | 24.98 | 0.59 | 3.29 | 74.0 | 82.24 | 5.13 | 10.95 | 1.68 | 8,046 | 14,483 |
| 11. Graf Moltke | 63.50 | 24.59 | 1.51 | 10.40 | 72.9 | 85.43 | 5.15 | 7.63 | 1.79 | 8,455 | 15,219 |
| 12. Hörde | 76.32 | 13.04 | 0.80 | 9.84 | 85.4 | 89.62 | 4.12 | 4.59 | 1.67 | 8,568 | 15,422 |
| 13. Holland | 73.96 | 20.19 | 0.99 | 4.86 | 78.6 | 88.53 | 5.07 | 5.31 | 1.07 | 8,763 | 15,773 |
| 14. Lothringen | 72.19 | 22.33 | 1.49 | 4.03 | 76.5 | 87.52 | 4.82 | 6.58 | 1.08 | 8,539 | 15,370 |
| 15. Mathias Stinnes | 71.70 | 19.99 | 1.28 | 7.03 | 78.2 | 89.05 | 4.90 | 4.38 | 1.67 | 8,842 | 15,916 |
| 16. Mont Cenis | 53.96 | 25.67 | 2.50 | 17.87 | 67.8 | 83.14 | 5.40 | 9.33 | 2.13 | 8,291 | 14,924 |
| 17. Oberhausen | 71.96 | 17.32 | 0.57 | 10.15 | 80.6 | 88.82 | 4.88 | 5.22 | 1.08 | 8,723 | 15,701 |
| 18. Pluto | | | | 1.52 | 2.78 | | | 8.70 | 0.42 | 8,311 | 14,960 |
| 19. Recklinghausen | 66.90 | 27.18 | 1.44 | 4.48 | 71.1 | 84.63 | 5.43 | 6.72 | 1.52 | 8,655 | 15,579 |
| 20. Shamrock | 71.53 | 20.44 | 1.10 | 6.93 | 77.8 | 89.55 | 5.21 | 3.95 | 1.29 | 8,957 | 16,123 |
| 21. Victoria Mathias | 70.46 | 25.28 | 0.98 | 3.28 | 73.6 | 84.31 | 5.01 | 9.05 | 1.63 | 8,251 | 14,852 |
| 22. Vollmond | 69.75 | 21.52 | 0.92 | 7.81 | 76.4 | 87.39 | 5.23 | 5.96 | 1.42 | 8,707 | 15,673 |
| 23. Westende | 72.43 | 18.55 | 1.18 | 7.84 | 79.6 | 89.43 | 5.23 | 3.66 | 1.68 | 8,977 | 16,159 |
| 24. Zollverein | 67.03 | 25.03 | 1.64 | 6.30 | 72.8 | 86.65 | 5.16 | 6.17 | 2.02 | 8,623 | 15,521 |
| <i>Saar Coals.</i> | | | | | | | | | | | |
| 1. Dudweiler | 59.72 | 33.19 | 1.32 | 5.77 | 64.3 | 84.23 | 5.50 | 9.22 | 1.05 | 8,392 | 15,106 |
| 2. Frankenholtz | 54.38 | 37.21 | 1.99 | 6.42 | 59.4 | 84.51 | 5.50 | 8.62 | 1.37 | 8,450 | 15,210 |
| 3. Friedrichsthal | 54.43 | 37.14 | 2.03 | 6.40 | 59.4 | 83.21 | 5.45 | 10.13 | 1.21 | 8,258 | 14,864 |
| 4. Heinitz | 56.13 | 29.17 | 2.24 | 12.46 | 65.8 | 82.38 | 5.44 | 11.27 | 0.91 | 8,133 | 15,179 |
| 5. von der Heydt | 50.93 | 34.40 | 3.90 | 10.77 | 59.7 | 80.95 | 4.93 | 12.81 | 1.31 | 7,781 | 14,006 |
| 6. St. Ingbert | 65.63 | 29.81 | 1.73 | 2.83 | 68.8 | 85.38 | 5.23 | 8.71 | 0.68 | 8,409 | 15,136 |
| 7. Itzenplitz | 59.02 | 32.67 | 3.61 | 4.70 | 64.4 | 81.92 | 5.29 | 11.65 | 1.14 | 8,032 | 14,458 |
| 8. König | 54.32 | 37.72 | 1.21 | 6.75 | 59.0 | 83.32 | 5.65 | 8.75 | 2.28 | 8,418 | 15,152 |
| 9. Kohlwald | 54.56 | 35.74 | 4.05 | 5.65 | 60.4 | 81.37 | 5.57 | 12.03 | 1.03 | 8,064 | 14,515 |
| 10. Püttlingen | 53.72 | 31.12 | 3.93 | 11.23 | 63.3 | 80.94 | 5.39 | 12.73 | 0.94 | 7,933 | 14,279 |
| 11. Reden | 56.08 | 34.25 | 3.45 | 6.22 | 62.1 | 80.79 | 5.60 | 12.51 | 1.10 | 8,008 | 14,414 |
| <i>Upper Bavaria Coals.</i> | | | | | | | | | | | |
| 1. Haushamer Grobkohle | 43.19 | 36.13 | 7.37 | 13.31 | 54.5 | 73.14 | 5.57 | 15.15 | 6.14 | 7,479 | 13,462 |
| 2. Pensberger Förderkohle II | 33.08 | 34.69 | 10.18 | 22.05 | 48.8 | 70.50 | 5.65 | 16.12 | 7.73 | 7,185 | 12,933 |
| <i>Saxon Brown Coal.</i> | | | | | | | | | | | |
| 1. Alfred | 23.27 | 33.39 | 36.26 | 7.08 | 41.1 | 73.08 | 5.81 | 17.37 | 3.74 | 7,304 | 13,247 |
| 2. Bach bei Ziebingen | 24.45 | 28.23 | 45.33 | 1.99 | 46.4 | 68.20 | 4.86 | 25.06 | 1.88 | 6,210 | 11,178 |
| 3. Meuselwitz Fortschritt | 27.27 | 37.28 | 27.13 | 8.32 | 42.2 | 68.89 | 5.69 | 22.76 | 2.66 | 6,669 | 12,004 |
| 4. Gnadenhütte bei Mühl- ingen | 18.81 | 33.02 | 48.68 | 9.49 | 36.3 | 71.70 | 6.54 | 18.56 | 3.20 | 7,380 | 13,284 |
| 5. Greppen | 27.45 | 38.64 | 22.85 | 11.06 | 41.5 | 65.62 | 4.92 | 26.54 | 2.92 | 5,983 | 10,769 |
| 6. Lutzendorf | 19.63 | 27.57 | 47.45 | 5.35 | 41.6 | 65.93 | 5.91 | 19.96 | 8.20 | 6,769 | 12,184 |
| 7. Marie Louise | 27.61 | 35.83 | 29.27 | 7.29 | 43.5 | 71.57 | 5.88 | 16.89 | 5.66 | 7,281 | 13,106 |
| <i>Lignite and Turf.</i> | | | | | | | | | | | |
| 1. Lignite von Josefszeche in Schwanenkirchen | 18.11 | 25.65 | 40.35 | 15.89 | 41.4 | 65.81 | 5.81 | 21.82 | 6.56 | 6,589 | 11,860 |
| 2. Pressdorf von Hofmark- Steinfeld | 25.97 | 52.28 | 16.47 | 5.28 | 33.2 | 63.02 | 5.73 | 30.76 | 0.49 | 5,813 | 10,463 |
| (3) Ostrach (turf) | 27.64 | 52.78 | 14.06 | 5.52 | 34.4 | 57.11 | 5.84 | 36.29 | 0.76 | 5,141 | 9,254 |
| 4. Turf of Pschorrschwaige | 22.69 | 41.26 | 29.14 | 6.91 | 35.5 | 60.61 | 5.72 | 33.26 | 0.41 | 5,506 | 9,911 |
| <i>Stone-coal Briquettes.</i> | | | | | | | | | | | |
| 1. Dahlhausen Tiefbau | 77.52 | 14.16 | 1.06 | 7.26 | 84.6 | 90.79 | 4.42 | 3.41 | 1.38 | 8,811 | 15,860 |
| 2. Haniel & Co | 77.50 | 12.63 | 1.77 | 8.10 | 86.0 | 90.94 | 4.60 | 3.48 | 0.98 | 8,873 | 15,971 |
| 3. Hugo Stinnes, Strass- burg | 69.42 | 21.89 | 1.76 | 6.93 | 76.0 | 88.55 | 4.87 | 5.28 | 1.30 | 8,704 | 15,667 |
| 4. Stachelhaus & Buchloh | 77.77 | 13.98 | 2.10 | 6.15 | 81.8 | 90.13 | 4.47 | 3.92 | 1.48 | 8,851 | 15,932 |

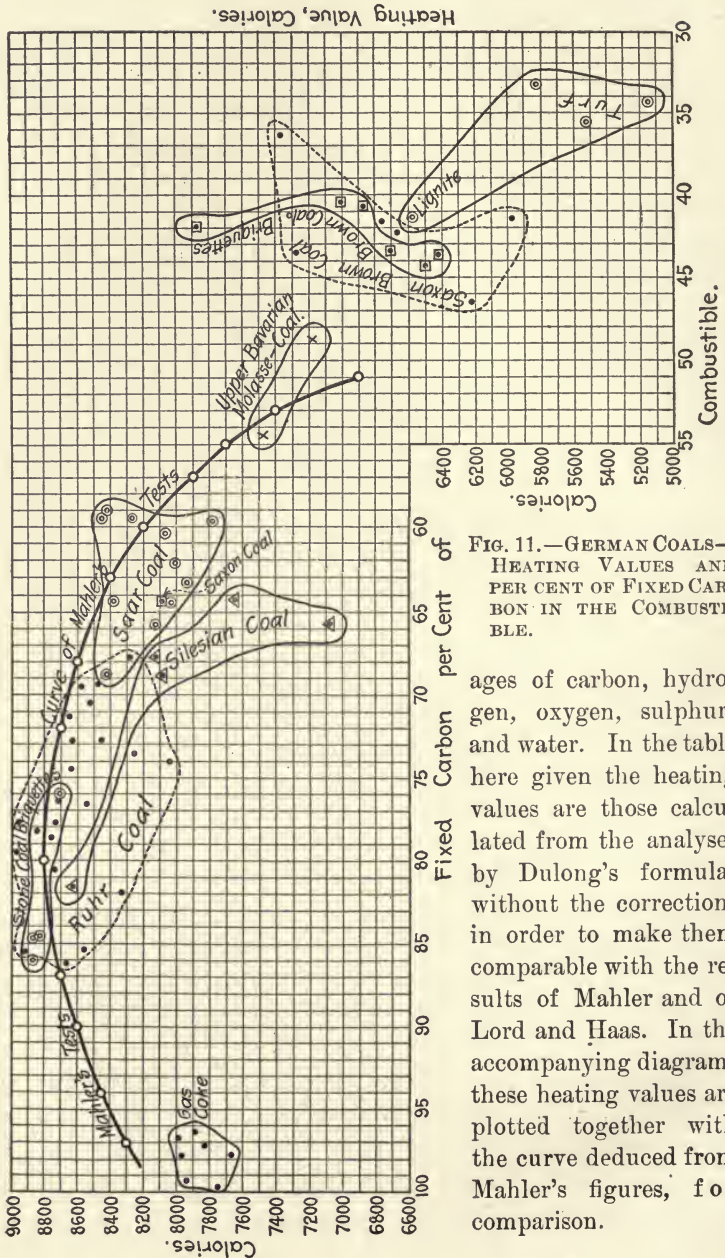

FIG. 11.—GERMAN COALS—HEATING VALUES AND PER CENT OF FIXED CARBON IN THE COMBUSTIBLE.

ages of carbon, hydrogen, oxygen, sulphur, and water. In the table here given the heating values are those calculated from the analyses by Dulong's formula, without the correction, in order to make them comparable with the results of Mahler and of Lord and Haas. In the accompanying diagram, these heating values are plotted together with the curve deduced from Mahler's figures, for comparison.

ANALYSES OF GERMAN COALS—Continued.

| | Air-dried Coal. | | | | Fixed Carbon—Per cent Combustible. | Combustible. | | | | Calculated Heating Value of Combustible. | |
|--|-----------------|------------------|--------|-------|------------------------------------|--------------|------|-------|------|--|----------------|
| | Fixed Carbon. | Volatile Matter. | Water. | Ash. | | C | H | O+N | S | Calories. | B.T.U. per lb. |
| <i>Silesian Coals.</i> | | | | | | | | | | | |
| 1. Deutschland (Gottesberg) | 62.29 | 32.69 | 1.58 | 3.44 | 65.6 | 75.70 | 4.80 | 18.29 | 1.21 | 7,075 | 12,735 |
| 2. Viktor | 74.63 | 16.89 | 1.65 | 6.83 | 81.5 | 88.64 | 4.63 | 5.39 | 1.34 | 8,622 | 15,520 |
| 3. Guido | | | 1.67 | 5.05 | | 83.29 | 5.20 | 10.80 | 0.61 | 8,138 | 14,648 |
| 4. Königin Louise | 58.70 | 26.54 | 2.28 | 12.48 | 68.9 | 82.83 | 5.04 | 10.29 | 1.84 | 8,093 | 14,567 |
| 5. Mathilde | 63.50 | 30.13 | 2.05 | 4.32 | 67.8 | 83.64 | 5.02 | 10.54 | 0.80 | 8,119 | 14,614 |
| 6. Paulus | 61.07 | 33.86 | 1.95 | 3.12 | 64.3 | 77.91 | 4.64 | 15.97 | 1.48 | 7,649 | 13,768 |
| <i>Saxon Coals.</i> | | | | | | | | | | | |
| 1. Kaisergrube Gersdorf bei Oelsnitz | 56.23 | 31.34 | 8.91 | 3.52 | 64.2 | 81.59 | 5.44 | 11.49 | 1.48 | 8,071 | 14,528 |
| 2. Vereinigt Feld Bockwa-Hohndorf | | | 3.50 | 5.50 | | 82.00 | 5.46 | 10.55 | 1.99 | 8,017 | 14,431 |
| 3. Zwickau - Oberhohndorf Wilhelmschacht | | | 3.68 | 3.22 | | 81.58 | 5.74 | 12.00 | 0.68 | 8,135 | 14,643 |
| <i>Brown Coal Briquettes.</i> | | | | | | | | | | | |
| 1. Stempel Fürst Bismarck | 32.14 | 44.36 | 15.77 | 7.73 | 42.0 | 71.05 | 6.09 | 19.88 | 2.98 | 7,879 | 14,182 |
| 2. Wurfel-Brikett C. Ilse | 34.84 | 45.06 | 14.77 | 5.33 | 43.6 | 70.00 | 5.09 | 23.93 | 0.98 | 6,423 | 11,570 |
| 3. Wurfel-Brikett S. Rechenberg & Cie | 33.42 | 42.13 | 18.95 | 5.50 | 44.2 | 68.49 | 5.61 | 24.58 | 1.32 | 6,499 | 11,699 |
| 4. Stempel Rositz | | | 19.40 | 6.68 | | 69.98 | 5.84 | 22.15 | 2.03 | 6,822 | 12,230 |
| 5. Gewerkschaft Schwarzenfeld | 30.88 | 40.34 | 10.26 | 18.52 | 43.4 | 67.68 | 5.90 | 22.24 | 4.18 | 6,701 | 12,058 |
| 6. Stempel Siegfried | 30.84 | 45.57 | 13.65 | 9.94 | 40.4 | 70.23 | 5.99 | 20.40 | 3.38 | 7,000 | 12,600 |
| 7. Zeche Waldau | 29.60 | 43.34 | 16.57 | 10.49 | 40.6 | 69.88 | 5.76 | 20.91 | 3.45 | 6,870 | 12,366 |
| <i>Gas Coke.</i> | | | | | | | | | | | |
| 1. Bonifacius (Ruhr) | 84.56 | 3.17 | 1.53 | 10.74 | 96.4 | 93.50 | 1.22 | 4.12 | 1.16 | 7,894 | 14,209 |
| 2. Camphausen (Saar) | 85.14 | 2.80 | 1.79 | 10.27 | 96.8 | 94.28 | 1.14 | 2.96 | 1.62 | 7,992 | 14,386 |
| 3. Consolidation (Ruhr) | 90.58 | 0.21 | 1.79 | 7.42 | 99.8 | 93.82 | 0.77 | 4.45 | 0.96 | 7,748 | 13,946 |
| 4. Ewald (Ruhr) | 83.98 | 2.51 | 2.33 | 11.18 | 97.1 | 93.28 | 1.04 | 4.32 | 1.36 | 7,812 | 14,062 |
| 5. Heinitz (Saar) | 91.78 | 0.74 | 0.96 | 6.52 | 99.2 | 95.20 | 0.84 | 3.08 | 0.88 | 7,940 | 14,292 |
| 6. Königin Louise (Ober-schles.) | 87.93 | 1.93 | 3.73 | 6.41 | 97.9 | 96.09 | 0.60 | 2.23 | 1.08 | 7,972 | 14,350 |
| 7. Rhein, Elbe u. Alma (Ruhr) | 89.75 | 2.04 | 1.71 | 6.50 | 97.8 | 92.93 | 0.88 | 5.23 | 0.96 | 7,679 | 13,822 |

Selection of Coal for Steam-boilers.—The selection of the kind of coal to be used in any given boiler-plant depends: 1, on the relative cost per ton of the different kinds delivered at the boiler; 2, on their relative total heating value per pound or per ton; 3, on the relative percentage of the heating value which may be utilized in the boiler; 4, on the maximum capacity, or horse-power, which may be developed by the boilers with different coals; 5, on the relative cost of handling the different coals and the ashes produced from them; and 6, on their relative smokelessness when used in the particular boilers and furnaces under consideration.

In some locations only one kind of coal is practically available, as when the boilers are located near a coal-mine, all other kinds being relatively too high-priced on account of the freight that must be paid

on them. In such cases, for the best results, the furnace and the draft must be adapted to the coal at hand. If the coal is of poor quality, the grate surface must be large relatively to the heating surface. If it is anthracite pea or culm, the draft must be strong, and, unless the grate surface is very large, mechanical draft may be necessary. If the coal is bituminous, the area of the grate, in proportion to the heating surface, will depend on the quality; the poorer the quality the larger the grate required. In other locations many different varieties of coal may be available, and then all of the points above enumerated may have to be taken into account in making a selection.

Usually the coal which is sold at the lowest price per ton is the most economical one for those furnaces and boilers that are adapted to it. Its price is apt to be depreciated below the normal price due to its heating value, because its market is limited by the number of boilers to which it is adapted, and also by the cost of freighting it to more distant markets. Freight charges being the same per ton on poor as on good coal, it does not pay to haul poor coal long distances; it is better to sell it at a relatively low price in nearby markets. On the other hand, good coals are apt to be relatively overvalued in the market, since they can be used in all kinds of furnaces, are more desirable in every way, and they may be transported long distances to find the best markets. On this account a boiler and furnace should be adapted, whenever possible, to use the poorest kind of coal in the market.

But this is not always possible. The boiler and chimney being already in place and the requirements of the engines being such that the boiler must be driven to its maximum capacity, then a coal must be selected from which this maximum capacity may be obtained:

For maximum evaporation per pound of coal, that coal should be selected in which the product of its total heating value per pound by the percentage of this heating value which may be utilized by the boiler, is a maximum. For instance, suppose an anthracite egg-coal of a heating value of 13,000 heat units per pound and a good bituminous coal of 14,000 heat units are equally available, but the furnace is such that the boiler will give 75 per cent efficiency with the anthracite and only 65 per cent with the bituminous, then the relative values of the two coals for that particular boiler are 975 for the anthracite and 910 for the bituminous. If a semi-bituminous coal with a heating value of 14,500 heat units is also available, and the boiler-efficiency with that coal is 70 per cent, then its relative figure will be 1015. If maximum capacity, rather than economy, is the prime consideration, then the

bituminous coal, with the lowest relative economy of the three, may be selected if it is found that it is more free-burning than the others, so that a larger quantity of it may be burned in the furnace with the draft that is available. If economy of cost is the chief consideration, the boiler having ample capacity with either fuel, then that coal will be selected which evaporates the most water for the least money, or in case of the three coals considered, the one in which its price per ton divided by its relative value figure, 975, 910, or 1015, as the case may be, is the least. If their costs per ton are respectively \$1.95, \$1.82, and \$2.03, then the prices of the coals are directly proportioned to their available actual values for the particular case, and as far as cost is concerned it is a matter of indifference which is selected. The selection may then depend on the trifling difference between the coals in the relative cost of handling them, or in handling the ash made from them, the bituminous coal usually requiring the greater labor on the part of the fireman. If the location is in a city, where smoke is objectionable, the anthracite coal may be selected on account of its smokelessness.

APPENDIX TO CHAPTER V.

TESTING THE RELATIVE VALUE OF DIFFERENT COALS.*

The writer recently had occasion to make a test of three different lots of coal for the purpose of determining their relative fuel value, to be used as a basis of a very large contract. During the tests some facts were learned which may prove of importance in other similar tests, and which show that the apparent fuel value as determined by a single series of boiler tests under uniform conditions may not be the true relative value in actual use.

This general fact was shown by the writer in a paper read at the Cleveland meeting of the American Society of Mechanical Engineers in 1883, on the "Evaporative Power of Bituminous Coal," in which paper he criticised the coal tests made for the government under the direction of Quartermaster-General M. C. Meigs, and showed that the relative value of many bituminous coals as shown by these tests, in comparison with anthracite, was far below their real relative value. The statement was then made that "the relative value of bituminous coal is a variable quantity, depending upon the conditions under which it is burned."

Thus one Pittsburg bituminous coal tested by General Meigs gave a value of 96.8, as compared with 100 for anthracite, when tested in one boiler, and the same coal a value of only 76.2 when tested in another boiler. Johnson's tests in 1844 gave Pittsburg coal a value of 80, and Babcock & Wilcox Company's tests in 1883 gave it a value of 99.5, as compared with 100 for anthracite.

* An article by the author published in *The Engineering and Mining Journal*, July 19 1890.

chimney 28 inches diameter and 50 feet high above the grate. At 10 square feet of heating surface per horse-power, the two boilers should develop 202.4 horse-power.

The three coals were almost identical in appearance, all being very friable and bright, semi-bituminous. A proximate analysis made subsequent to the boiler test from samples selected during the tests gave the following analysis made on dry coal:

| Coal. | A. | B. | C. |
|------------------------|-------|-------|-------|
| Fixed carbon | 77.17 | 74.23 | 74.29 |
| Volatile matter | 17.49 | 16.39 | 17.97 |
| Total combustible..... | 94.66 | 90.62 | 92.26 |
| Ash..... | 5.34 | 9.38 | 7.74 |

The proportions of the boiler, grate, and chimney being judged as about right for developing the rated horse-power with good economy, it was determined to make a trial of the three coals under the maximum draft which the chimney would give, and to preserve the conditions of the three tests as uniform as possible. The firing was carefully watched, to avoid the possibility of air-holes being formed in the rear of the grate or in the corners; an even bed of coals 10 or 12 inches thick was steadily carried, and the top of the bed was raked only very slightly and at long intervals to check the slight tendency which the coal had to coking on the surface.

Coal A was first tested, and proved to be a remarkably good coal, burning very freely, and making almost no clinker, the fine white ashes, with a portion of the black friable coal, falling steadily through the grates, and the ash-pit remaining bright for several hours after starting. The grates required a slight cleaning by a slice-bar only once during the test.

The results show an evaporation of 9.311 pounds of water from and at 212 degrees per pound of coal, and 10.167 pounds per pound of combustible—not as much by from 10 to 15 per cent as would be expected under the conditions; but the deficiency was explained by a very high temperature of the chimney-gases, considerably over 680 degrees by the mercury thermometer. The pyrometer unfortunately got out of order during the test, and its figures were unreliable. The rate of evaporation per square foot of heating surface, 4.33 pounds, would scarcely account for the high temperature, and the cause was afterward found to be a faulty setting of the boiler, by which the lower rows of tubes were made partly ineffective, the upper rows carrying off the bulk of the gases at a high velocity and temperature. This condition being constant during all the tests, however, it did not interfere with the test of the relative value of the coals. The capacity, 253.9 horse-power, was 25 per cent above the rated capacity of the boilers, estimating it at 10 square feet per horse-power.

The lesson to be drawn from this test, in addition to that learned about the imperfect setting, was that with the same setting better economy of coal could be gained by reducing the boiler capacity, either by checking the draft or by reducing the area of grate surface.

The test of coal B was then proceeded with, the conditions being unchanged. The coal acted very differently from coal A. Clinker was soon formed, and the grates required frequent slicing to allow enough air to be admitted to burn the coal at a rate sufficient to cause the boilers to develop their rated capacity.

The results gave a capacity of only 199 horse-power, or less than the rating. The evaporation per pound of coal was only 8.665 pounds, or 93.06 per cent of that obtained with coal A, while the efficiency as shown by the evaporation per pound of combustible was also nearly 1 per cent less. The high



temperature of the chimney-gases continued, the thermometer rising to 680 degrees before removal to prevent its breakage, but not so rapidly as in the previous test. The amount of ashes obtained in the boiler test, 14.0 per cent, as against 8.42 per cent with coal A, left no doubt as to the inferiority of coal B. It gave 7 per cent less economy while reducing the boiler capacity nearly 25 per cent.

Coal C was then tested under the same conditions. It burned so nearly like coal A that no difference could be observed for two or three hours, when it was noticed that the ash-pit was becoming dark, and that evaporation was not proceeding quite so rapidly as at first. The fire was becoming a little sluggish through accumulation of ashes. The bars required to be sliced two or three times during the test. The result showed nearly 224.1 horse-power, 12 per cent less than with coal A, but the evaporation of water per pound of coal was almost exactly the same, 9.302 lbs. as compared with 9.311 lbs., and the apparent relative value of the coal was 99.9 per cent of that of coal A. The evaporation of water from and at 212 degrees per pound of combustible, however, was higher than that with coal A, in the ratio of 10.311 to 10.167 lbs., or as 100 to 98.60.

It was quite evident that the increased efficiency of the boiler when coal C was tested was due to the ashes of the coal choking the passage of air through the fire just to such an extent as to cause the coal to be burned more slowly, under the given conditions of grate area, setting of boiler, and chimney draft, and so slowly as to allow of more of the heat produced being absorbed by the water in the boiler and to allow less of it to pass up the chimney.

It was reasonable to infer, therefore, that if coal A had been burned more slowly, as it might have been, by a slight checking of the chimney draft by the damper, the boiler would have shown as high an efficiency as it did when coal C was tested, and, *per contra*, that if coal C had been burned as rapidly as coal A, the efficiency of the boiler with coal C would have been as low as it was with coal A. We may then state the problem, if coal C showed a fuel value of 99.9 as compared with coal A when the boiler efficiency was relatively 100, what would it show if the efficiency was reduced to 98.6? and solve it by the proportion:

$$\begin{array}{cccc} \text{Eff'y C.} & \text{Eff'y A.} & \text{C.} & \text{C. corrected.} \\ 100 & : & 98.6 & :: 99.9 & : & 98.50. \end{array}$$

The figure 98.50 may, therefore, be taken as the corrected relative value of coal C as compared with coal A.

The two coals were tested again, as shown in the table, tests 4 and 5, the conditions being changed by reducing the grate surface from 50.8 square feet to 43.2 square feet, and thereby increasing the ratio of heating to grate surface from 39.8 to 46.9. In other respects the conditions were preserved as nearly as possible the same as in the former tests. As was expected, the actual evaporation from and at 212 degrees was increased for both coals, from 9.311 to 9.419 for coal A, and from 9.302 to 9.495 for coal C. The relative efficiency of the boiler was also increased from 10.167 to 10.214 for coal A, and from 10.311 to 10.466 for coal B. Comparing the evaporation per pound of coal in tests 4 and 5, the apparent relative value of coal C is 100.81 instead of 99.9 as it appeared in the comparison of tests 1 and 3, thus reversing the conclusion which might have been drawn from the latter tests, which showed that coal C was one-tenth of one per cent inferior to coal A, and making it appear that it was eight-tenths of one per cent superior.

The relative efficiency of the boiler in tests 4 and 5 was 97.59 for coal A and 100 for coal C. Making the correction as before for relative efficiencies, we have the problem, if coal C gave a relative value of 100.81 when the boiler efficiency was 100, what would its value be if the efficiency was 97.59? and the proportion

Eff'y C. Eff'y A. C. C. corrected.
 100 : 97.59 :: 100.81 : 98.38,

which figure agrees as closely as should be expected with the corrected relative value, 98.50, found in tests 1 and 3, and the average of these results, or 98.44, may be taken as the true relative fuel value of coal C, as compared with 100 for coal A.

The single test of coal B, which showed a relative fuel value, as compared with A, of 93.06, gives a value, when similarly corrected for boiler efficiency, of 93.90.

The three coals, A, B, and C, being of the same general quality, as determined by the relative percentage of fixed carbon and volatile matter, shown by analysis, differing only in their percentage of ash, it would naturally be expected that their true relative fuel value in practice under the best available conditions for each coal would be in direct proportion to the percentage of total combustible matter actually burned in the boiler test, which is found by subtracting the ash and refuse withdrawn from the fire during the test from 100 per cent. Making the calculation of relative value on this basis we find a most remarkable coincidence, as follows:

| | Coal B. | Coal C, test No. 3. | Coal C, test No. 5. |
|--|---------|------------------------|------------------------|
| Corrected value by boiler test, A = 100... .. | 93.90 | 98.50 | 98.38 |
| Relative value, by per cent combustible, A = 100 | 93.91 | 98.50 | 98.37 |

It will not be safe to conclude from this coincidence, however, that it is a general rule that the fuel value of coal is in proportion to percentage of combustible, for the quality of the combustible matter varies in coals of different general chemical constitution, and in coals containing a very high percentage of volatile matter, as in most bituminous coals mined west of Pittsburg, it is not possible in any ordinary boiler-furnace to thoroughly burn this volatile matter. It may, however, be considered as a general rule for coals of approximately the same chemical constitution.

It is moreover not safe to generalize that the true relative fuel value of two coals may be always obtained by multiplying their apparent value as found in a boiler test by the ratio of boiler efficiencies found in the tests of the two coals; but the rule may be stated as follows:

If in a comparative test of two coals of approximately similar chemical constitution, the apparent relative fuel value as shown by the boiler test differs less than the difference of boiler efficiency in the two tests, then the apparent relative values should be corrected for the difference in boiler efficiency.

This rule will apply in the case of coals A and C, since their apparent fuel value varied only from - 0.1 to + 0.8 per cent, while the boiler efficiency varied from 1.4 to 2.41 per cent, but it does not apply to the comparison of coals A and B, in which the apparent fuel value differed 6.94 per cent, while the boiler efficiency varied only 0.87 per cent.

The reason why the application of the rule is thus limited requires some explanation. In the comparison of coals A and C, it is evident that the apparent relative value of A is lower than it should be (or C higher), because A was burned too fast, which caused the lower efficiency of the boiler, and also that its relative value could in practice be made greater by checking the draft, without bringing the rate of evaporation below the normal capacity of the boiler. In the case of coal B, however, the efficiency of the boiler is not lower because the coal was burned too fast—in fact it was burned too slowly, as the boiler did not develop its rated capacity. Slow burning should of itself give high efficiency, and that it did not give higher efficiency than coals A and C, but lower, is no doubt due to the fact that the greater amount of ash and clinker it made required the fires to be cleaned oftener, letting cold air pass

through the fire-door during the operation, and an excess of air pass through the grates at the time of every cleaning. By no change of draft or of grate-surface could the efficiency be raised, without still further decreasing the already low capacity, hence the correction for low efficiency should not be made to get the practical fuel value.

Making the correction for boiler efficiency in the case of coal B does, in fact, raise its apparent relative value from 93.06 to 93.90, which is almost identical with the figure obtained from comparison of the percentage of combustible, 93.91, and it shows that if the efficiency of the boiler could, by any means, have been raised to the same value as was given in the test No. 1 of coal A, then the relative value would have been 93.90; but as the efficiency could not have been so raised without diminishing the capacity of the boiler below its normal rate, the supposition is not of practical value, and the correction should not be made. The fact is that when the ash in a coal is so great in amount as to necessitate frequent cleaning of the fires, its effect in reducing the fuel value of the coal is greater than that due to its mere percentage. It reduces the capacity of the boiler as well as its efficiency, besides giving extra trouble in handling the fires and getting rid of the ash itself.

The writer is not aware that other experimenters on relative values of fuel have made use of the corrections for boiler efficiency described above, but he believes that the corrections, applied within the limits indicated, are of sufficient importance to receive attention in future tests of this kind, even when the tests are made for commercial and not for scientific purposes.

COMPARATIVE CALORIMETRIC TESTS OF COALS.*

The writer, in his paper on "The Efficiency of a Steam-boiler," presented at the St. Louis meeting, May, 1896 (Trans. A. S. M. E., vol. xvii. p. 649), expressed the opinion that the variations in results of calorimetric tests of coal "throw doubt upon all calorimetric work until a sufficient number of tests shall have been made by different experimenters and with different calorimeters upon similar samples, and until tests so made show a reasonable degree of uniformity." The results of tests of two coals by three different calorimeters were given in the paper. Mr. Barrus has since made tests of the same coals, using his own calorimeter, and they have been analyzed by Mr. Henry J. Williams, by Mr. C. H. Benedict, and also by some senior students of an engineering college in connection with their thesis work. The results of all the calorimeter tests and of the heating value, calculated from the analyses, are given below. Coal No. 1 was from Jackson Co., Ohio, and No. 2 from New River, W. Va.

| | Heating Value per Pound Coal, | | Heating Value per Pound Combustible, | | Ratio (2)÷(1). |
|----------------------------------|----------------------------------|--------|---|--------|-------------------|
| | (1) | (2) | (1) | (2) | |
| Carpenter calorimeter..... | 13,170 | 15,200 | 14,620 | 16,210 | 1.109 |
| Thompson calorimeter (Boston).. | 11,913 | 13,066 | 13,302 | 13,799 | 1.037 |
| Thompson calorimeter (St. Louis) | 11,894 | 13,527 | | | |
| Barrus calorimeter..... | 12,705 | 14,631 | 13,646 | 15,320 | 1.123 |
| Analysis, Williams's..... | 12,323 | 14,452 | 13,208 | 15,197 | 1.150 |
| Analysis, students'..... | 10,786 | 14,016 | 12,145 | 14,885 | 1.226 |
| Analysis, Benedict's..... | | 15,215 | | 15,967 | |

* Appendix XIV to the Report of the Committee on Boiler Trials, Trans. A. S. M. E., vol. xxi. p. 68.

The results of Mr. Barrus's calorimetric test and of Mr. Williams's analyses show a fairly satisfactory agreement, but they are so much below the results of the Carpenter calorimeter, and so much above the results of the Thompson calorimeter, that the true heating value of these coals is still a matter of doubt. The results of the analysis of coal No. 1 by the students is so far below the results of the other tests of the same coal that it is of interest only in showing what great errors in analyses are possible. The ratio of the heating values of the combustible of coals Nos. 1 and 2 show that the relative values as well as the absolute values obtained by different calorimeters are apt to vary widely.

Mr. Benedict's analysis is given by Professor Carpenter, as follows, on dry coal: C, 85.07; H, 5.01; N, 0.82; O, 3.79; ash, 4.71; S, 0.30; calculated heat value, 15,215 B.T.U. The samples furnished to all the experimenters were identical. The coal was crushed in a coffee-mill, thoroughly mixed, and several small bottles were filled with samples of the crushed coal at the same time.

More recently the writer has obtained comparative figures by three different calorimeters and by analysis of two samples of Mt. Olive (Ill.) coal, as follows:

| | Heating Value per lb. Combustible, B. T. U. | | Ratio (2) ÷ (1) |
|---|--|--------|--------------------|
| | (1) | (2) | |
| Prof. R. C. Carpenter, Carpenter calorimeter..... | 13,700 | 13,800 | 1.007 |
| Prof. N. W. Lord, Mahler calorimeter | 13,870 | 13,968 | 1.007 |
| Prof. W. B. Potter, Thompson calorimeter..... | 13,687 | 13,787 | 1.007 |
| Analysis by Ricketts & Banks..... | 14,020 | 13,955 | 0.996 |
| Average..... | 13,819 | 13,878 | 1.004 |

All of these results show a remarkably close agreement. The greatest variation, that between the results by the Thompson calorimeter and by analysis, is only 2.4 per cent. These figures would indicate that the Thompson calorimeter is fairly reliable, but a very different conclusion must be drawn from the results of the tests by two Thompson calorimeters of the Jackson and the New River coals, which are far below the results obtained by the Carpenter and the Barrus calorimeters.

The conclusion to be drawn from the two series of tests tabulated above is that closely concordant results may be obtained from different calorimeters when properly handled by expert chemists, and that these results will agree with the results calculated from accurate analyses; but that occasionally very erroneous results may be obtained, and that

a single calorimetric test, unchecked by comparison with a test by another calorimeter, is to be regarded with suspicion, especially when the test is made with a Thompson calorimeter, when the reported heating value per pound of combustible is low compared with results of other tests of coal from the same region, and when the boiler-efficiency calculated from such calorimetric test is high.

APPARATUS FOR DETERMINING ON A LARGE SCALE THE HEATING VALUE OF DIFFERENT COALS.

The tests of American coals by Professor Johnson in 1842, and by General Meigs in 1882 (Trans. A. S. M. E., vol. iv. p. 249), were made by evaporating water into steam in ordinary steam-boilers. A steam-boiler of ordinary construction is not a good apparatus for determining the heating power of a fuel, for the following reasons:

1. We can have no assurance that the fuel is completely burned. In all coals containing volatile matter, the distilled gases may be chilled by the heating-surfaces of the boiler, and escape into the chimney unburned.

2. The heat generated by the fuel is carried away in four different portions: *a*, in the steam which leaves the boiler; *b*, in the "entrained" water which leaves with the steam; *c*, in the waste gases in the chimney; *d*, by radiation from the boiler and brickwork. The relative proportion of heat which disappears in each of these four different ways varies every instant, and the measurement of any one of the portions is an exceedingly difficult matter and liable to great errors.

3. The boiler and furnace having a large heat-absorbing capacity in proportion to the quantity of fuel burned during a test, it is difficult to insure that the conditions at the beginning and end of a test are the same; that is, that in addition to the four outlets for the heat of the fuel above mentioned, a fifth part of the heat has not been absorbed by the boiler and brickwork in making them hotter at the end of the test than at the beginning.

The author described and illustrated in 1886 (Trans. A. I. M. E., vol. xiv. p. 727, a proposed apparatus, in which an attempt is made to avoid to a great extent these sources of error. Its principal feature is that it is not a steam-boiler at all, but only a water-heater.

It consists of two sheet-metal cylinders, each 12 ft. long, the upper one 4 ft. in diameter, and the lower one 3 ft., and connected by a short neck at one end only. The upper cylinder is provided with

a fire-box 3 ft. 6 in. in diameter and 6 ft. long, and its rear end is filled with about 100 2-in. tubes. The lower cylinder is completely filled with 2-in. tubes. The fire-box is lined throughout with fire-brick, and contains a grate-surface 2 ft. wide by $2\frac{1}{2}$ ft. long. A hanging bridge-wall of fire-brick is placed in the upper part of the fire-box in the rear of the bridge-wall proper for the double purpose of presenting a hot fire-brick surface to the flame before allowing it to touch the heating-surfaces of the tubes and tube-sheet, and of changing its direction so as to cause the gases to thoroughly commingle and thus to insure complete combustion. In testing highly bituminous coals, it might be advisable to have more than one of these hanging walls, and to give the fire-box a greater length, to more certainly insure complete combustion of the gases. The gases of combustion pass through the tubes of the upper heater, then down through a fire-brick connection into the tubes of the lower heater, after leaving which they pass into the chimney. Air is fed to the fire, under the grate-bars, through a pipe leading from a fan-blower. The air is measured by recording the revolutions of the blower, and the measurement is checked by an anemometer in the air-pipe. Its weight should be calculated from the barometric pressure, and its contained moisture should also be determined. Its temperature should be taken before it enters the ash-pit. The temperature of the escaping gases should be taken by several thermometers, the bulbs of which reach to different portions of the chimney-connection. Cold water is supplied to the bottom of the lower heater at the chimney-end, its temperature being taken, before it enters, by a thermometer inserted in the pipe. The water supply-pipe may conveniently be attached to the city main. The water passes through the two heaters in an opposite direction to that of the gases of combustion, and escapes at the outlet-pipe at the top of the upper heater, by which it is taken to two measuring-tanks, which are alternately filled and emptied. The temperature of the outflowing water is taken by a thermometer inserted in the outflow-pipe. The rate of flow of water through the apparatus is regulated, so that the temperature of the outflowing water does not exceed 200° F. The measuring-tanks have closed tops, which prevent evaporation, small outlet-pipes being attached to the top of each which serve both as indicators when the tanks are full, and to allow air to escape from them when they are being filled with water.

The grate-surface being only 5 sq. ft. and the heating surface about 1000 sq. ft., a ratio of 200 to 1, or more than five times the usual proportion in a steam-boiler, and the water being much colder than that in a steam-boiler, the gases of combustion should be cooled down to near the temperature of the air supplied to the fire—especially when, as is usually the case, the water supply is colder than the air. For extremely accurate tests, the water might be cooled before entering by a refrigerating apparatus, or by ice.

The whole apparatus being thoroughly protected, by felting, from radiation, the heat generated by the fuel is all measured in the in-

crease of heat given to the water which flows through the apparatus, and in the increase of temperature of the gases of combustion as taken in the chimney, over the temperature of the air supplied to the fire. This increase, however, being in any case very slight, and the quantity of air being known, the amount of heat from the fuel which escapes up the chimney can be calculated with but small chances of error.

CHAPTER VI.

FUELS OTHER THAN COAL.

Coke.—Coke is the solid material left after evaporating the volatile ingredients of coal, either by means of partial combustion in furnaces called coke-ovens, or by distillation in the retorts of gas-works. Being a smokeless fuel it is available for use in the fire-boxes of internally fired boilers, which are not adapted to the smokeless combustion of soft coal, but its use for this purpose is quite limited on account of its cost.

The proportion of coke yielded by a given weight of coal is very different for different kinds of coal, ranging from 35 to 90 per cent.

Being of a porous texture, it readily attracts and retains water from the atmosphere, and sometimes, if it is kept without proper shelter, from 15 to 20 per cent of its gross weight consists of moisture.

ANALYSES OF COKE.

(From report of John R. Procter, Kentucky Geological Survey.)

| Where Made. | Fixed Carbon. | Ash. | Sulphur. |
|---|---------------|-------|----------|
| Connellsville, Pa. (Average of 3 samples) | 88.96 | 9.74 | 0.810 |
| Chattanooga, Tenn. " " 4 " | 80.51 | 16.34 | 1.595 |
| Birmingham, Ala. " " 4 " | 87.29 | 10.54 | 1.195 |
| Pocahontas, Va. " " 3 " | 92.53 | 5.74 | 0.597 |
| New River, W. Va. " " 8 " | 92.38 | 7.21 | 0.562 |
| Big Stone Gap, Ky. " " 7 " | 93.23 | 5.69 | 0.749 |

Pressed Fuel, or Briquettes.—A method of making pressed fuel from anthracite dust is described by E. F. Loiseau.* The dust is mixed with ten per cent of its bulk of dry pitch, which is prepared by separating from tar at a temperature of 572° F. the volatile matter it contains. The mixture is kept heated by steam to 212°, at which temperature the pitch acquires its cementing properties, and is passed between two rollers, on the periphery of which are milled out a series

* Trans. A. I. M. E., vol. viii. p. 314.

of semi-oval cavities. The lumps of the mixture, about the size of an egg, drop out under the rollers on an endless belt which carries them to a screen in eight minutes, which time is sufficient to cool the lumps, and they are then ready for delivery.

The enterprise of making the pressed fuel above described was not commercially successful, on account of the low price of other coal. In Europe, however, "*briquettes*" are regularly made of coal-dust (bituminous and semi-bituminous).

Coal-dust.—Dust when mixed in air burns with such extreme rapidity as in some cases to cause explosions. Explosions of flour-mills have been attributed to ignition of the dust in confined passages. Experiments made in Germany in 1893 show that pulverized fuel may be burned without smoke, and with high economy. The fuel, instead of being introduced into the fire-box in the ordinary manner, is first reduced to a powder by pulverizers of any construction. In the place of the ordinary boiler fire-box there is a combustion-chamber in the form of a closed furnace lined with fire-brick and provided with an air-injector similar in construction to those used in oil-burning furnaces. The nozzle throws a constant stream of the fuel into the chamber. This nozzle is so located that it scatters the powder throughout the whole space of the fire-box. When this powder is once ignited, which is readily done by first raising the lining to a high temperature by an open fire, the combustion continues in a regular manner under the action of the current of air which carries it in.

Powdered fuel was used in the Crompton rotary puddling-furnace at Woolwich Arsenal, England, in 1873.* It has recently been adopted successfully in this country in the rotary kilns used in the manufacture of Portland cement.

The *American Manufacturer* of Dec. 13, 1900, illustrates the Cyclone Pulverizer, a British invention, which is said to be in successful use grinding coal for dust-firing. We quote from it the following statement of the requisite conditions of success in the use of powdered fuel, and of the advantages claimed for it:

The best results can only be obtained when the following essentials are complied with, viz.:

(a) The fuel must be reduced cheaply to a very finely divided powder, and must be of a strictly uniform grade.

(b) The coal-powder mixed with air must be carried in an unbroken stream into the combustion-chamber.

* Journal of the Iron and Steel Institute, i., 1873, p. 91.

(c) The air-current must be so regulated that it will hold the coal-powder in suspension, when within the furnace, until complete combustion is effected.

(d) A sufficiently high temperature must be continuously maintained in the furnace, to ensure perfect combustion of the powder.

The problem of how to reduce the coal economically to the required standards of fineness and uniformity is the one thing which has given great trouble in developing new devices in firing-apparatus.

The advantages of the use of powdered fuel may be summarized as follows: 1. The most economical and complete combustion of the fuel, in a manner similar to gas-firing, but without the disadvantages of that system. 2. Complete smokelessness. 3. Reduced labor expenses, since one man can easily manage several furnaces. 4. Adaptability and ease of regulation to meet any requirements, especially when the work is that of steam-generation. 5. Decreased wear and tear of furnaces, in the case of internally fired boilers. 6. Saving of time in starting up furnaces, and rapid stoppage of firing, in case of necessity. 7. Less labor in removing refuse, which is light in quantity, and in the form of slag. 8. Intimate contact of the fuel with the air, whereby the minimum excess over the theoretical volume is employed, and waste of heat thus avoided.

Peat or Turf, as usually dried in the air, contains from 25% to 30% of water, which must be allowed for in estimating its heat of combustion. This water having been evaporated, the analysis of M. Regnault gives, in 100 parts of perfectly dry peat of the best quality: C 58%, H 6%, O 31%, Ash 5%.

In some examples of peat the quantity of ash is greater, amounting to 7% and sometimes to 11%. The specific gravity of peat in its ordinary state is about 0.4 or 0.5. It can be compressed by machinery to a much greater density. (Rankine.)

Clark ("Steam-engine," vol. i. p. 61) gives as the average composition of dried Irish peat: C 59%, H 6%, O 30%, N 1.25%, Ash 4%.

Applying Dulong's formula to this analysis, we obtain for the total heating value of perfectly dry peat 10,009 heat-units per pound, and for air-dried peat containing 25% of moisture 7507 heat-units per pound. To determine the "available" heating value, we must subtract the heat lost in the superheated steam in the chimney-gases, as calculated by the formula on page 25. For each pound of the air-dried peat the superheated steam is $0.25 + 0.75 \times .06 \times 9 = 0.655$ lb.; and if the temperature of the chimney-gases is 462° and that of the air-supply 62° the heat lost is

$$0.655 \times [(2 + 2 - 62) + 966 + (0.48 \times 250)] = 810 \text{ B.T.U.}$$

This subtracted from 7507 gives 6697 B.T.U. as the available heating value per pound of peat.

Deposits of peat are found in many places throughout the United States and Canada, but it has hitherto not been found practicable, commercially, to utilize them for fuel in competition with coal. In some countries in Europe, such as in Holland and Denmark, the peat industry is quite common. Papers on peat and its utilization will be found in "Mineral Industry," vol. ii., 1893, and vol. vii., 1898. The following table is given showing the comparative and calorimetric value, analyses of wood, peat, and coal, from a report made in Sweden in 1896. The analyses are of the fuel dry and free from ash.

| Composition. | Wood. | Peat. | Brown Coal. | Swedish Coal. | English Steam Coal. | Welsh Anthracite. |
|---------------|-------|-------|-------------|---------------|---------------------|-------------------|
| Carbon..... | 52.0 | 58.0 | 66.0 | 78.0 | 81.0 | 91.0 |
| Hydrogen..... | 6.2 | 5.7 | 4.6 | 5.1 | 5.2 | 3.5 |
| Oxygen..... | 41.7 | 35.0 | 28.0 | 14.8 | 11.5 | 3.5 |
| Sulphur..... | .. | .. | .. | 0.8 | 1.0 | 1.0 |
| Nitrogen..... | 0.1 | 1.2 | 1.0 | 1.3 | 1.3 | 1.0 |
| Calories..... | 4900 | 5700 | 6000 | 7500 | 8000 | 8600 |
| B. T. U..... | 8920 | 10260 | 10800 | 13500 | 14400 | 15480 |
| Moisture..... | 20 | 22 | 25 | 13.5 | 7.6 | 2.0 |

Wood.—Wood, when newly felled, contains a proportion of moisture which varies greatly in different kinds and in different specimens, ranging between 30% and 50%, and being on an average about 40%. After 8 or 12 months' ordinary drying in the air the proportion of moisture is from 20% to 25%. This degree of dryness, or almost perfect dryness if required, can be produced by a few days' drying in an oven supplied with air at about 240° F.

Perfectly dry wood contains about 50% of carbon, the remainder consisting almost entirely of oxygen and hydrogen in nearly the proportions which form water, the hydrogen being somewhat in excess. The coniferous family contain a small quantity of turpentine, which is a hydrocarbon.

ANALYSES OF WOODS, BY M. EUGENE CHEVANDIER.

| Woods. | Composition. | | | | |
|-------------|--------------|-----------|---------|-----------|-------|
| | Carbon. | Hydrogen. | Oxygen. | Nitrogen. | Ash. |
| Beech..... | 49.36% | 6.01% | 42.69% | 0.91% | 1.06% |
| Oak..... | 49.64 | 5.92 | 41.16 | 1.29 | 1.97 |
| Birch..... | 50.20 | 6.20 | 41.62 | 1.15 | 0.81 |
| Poplar..... | 49.37 | 6.21 | 41.60 | 0.96 | 1.86 |
| Willow..... | 49.96 | 5.96 | 39.56 | 0.96 | 3.37 |
| Average... | 49.70% | 6.06% | 41.30% | 1.05% | 1.80% |

Heating Value of Wood.—According to a table by S. P. Sharpless,* the ash varies from 0.03% to 1.20% in American woods, and the fuel value ranges from 3667 (for white oak) to 5546 calories (for long-leaf pine) = 6600 to 9883 British thermal units for dry wood.

The following table is given in several books of reference, the authority and quality of coal referred to not being stated.

The weight of one cord of different woods (thoroughly air-dried) is about as follows:

| | | |
|--------------------------------------|------------------------------------|---------------------|
| Hickory or hard maple..... | 4500 lbs. equal to 1800 lbs. coal. | (Others give 2000.) |
| White oak..... | 3850 “ “ 1540 “ “ | (“ 1715.) |
| Beech, red and black oak... 3250 “ “ | 1300 “ “ | (“ 1450.) |
| Poplar, chestnut, and elm.. 2350 “ “ | 940 “ “ | (“ 1050.) |
| The average pine..... | 2000 “ “ 800 “ “ | (“ 925.) |

Referring to the figures in the last column, it is said:

From the above it is safe to assume that 2¼ lbs. of dry wood are equal to 1 lb. average quality of soft coal and that the full value of the same weight of different woods is very nearly the same—that is, a pound of hickory is worth no more for fuel than a pound of pine, assuming both to be dry. It is important that the wood be dry, as each 10% of water or moisture in wood will detract about 12% from its value as fuel.

Taking an average wood of the analysis, perfectly dry, C, 50; H, 6; O, 42; N and ash, 2, its total heating value, by Dulong's formula, is 7765 B.T.U. per pound. If the wood contains 25% of moisture the analysis of the moist wood is C, 37.5; H, 4.5; O, 31.5; N and ash, 1.5, and its total heating value is 75% of 7765, or 5824 B.T.U. per pound. To obtain the “available” heating value we subtract the loss of heat in the steam formed from the water and the hydrogen in the wood, as calculated by the formula on page 25. Taking the temperature of the air supply at 62° and that of the escaping chimney-gases at 462°, this loss is 810 B.T.U., which subtracted from 5824 gives 5014 B.T.U. per pound as the available heating value.

Sawdust.—The heating power of sawdust is naturally the same per pound as that of the wood from which it is derived, but if allowed to get wet it is more like spent tan (which see below). The conditions necessary for burning sawdust are that plenty of room should be given it in the furnace, and sufficient air supplied on the surface of the mass. The same applies to shavings, refuse lumber, etc. Sawdust is

* Journal of the Charcoal Iron Workers' Association, vol. iv. p. 36.

frequently burned in sawmills, etc., by being blown into the furnace by a fan-blast.

Wet Tan-bark.—Tan, or oak-bark, after having been used in the processes of tanning, is burned as fuel. The spent tan consists of the fibrous portion of the bark. According to M. Pecelet, five parts of oak-bark produce four parts of dry tan; and the heating power of perfectly dry tan, containing 15% of ash, is 6100 British thermal units; whilst that of tan in an ordinary state of dryness, containing 30% of water, is only 4284 B.T.U. The weight of water evaporated from and at 212° by one pound of tan, equivalent to these heating powers, is, for perfectly dry tan, 5.46 lbs., for tan with 30% moisture, 3.84 lbs. Experiments by Prof. R. H. Thurston* gave with the Crockett furnace, the wet tan containing 59% of water, an evaporation from and at 212° F. of 4.24 lbs. of water per pound of the wet tan, and with the Thompson furnace an evaporation of 3.19 lbs. per pound of wet tan containing 55% of water. The Thompson furnace consisted of six fire-brick ovens, each 9 feet × 4 feet 4 inches, containing 234 square feet of grate in all, for three boilers with a total heating surface of 2000 square feet, a ratio of heating to grate surface of 9 to 1. The tan was fed through holes in the top. The Crockett furnace was an ordinary fire-brick furnace, 6 × 4 feet, built in front of the boiler, instead of under it, the ratio of heating surface to grate being 14.6 to 1. According to Prof. Thurston the conditions of success in burning wet fuel are the surrounding of the mass so completely with heated surfaces and with burning fuel that it may be rapidly dried, and then so arranging the apparatus that thorough combustion may be secured, and that the rapidity of combustion be precisely equal to and never exceed the rapidity of desiccation. Where this rapidity of combustion is exceeded the dry portion is consumed completely, leaving an uncovered mass of fuel which refuses to take fire.

Straw as Fuel.—Experiments in Russia showed that winter-wheat straw, dried at 230° F., had the following composition: C, 46.1; H, 5.6; N, 0.42; O, 43.7; Ash, 4.1. Heating value in British thermal units: dry straw, 6290; with 10% water, 5448. With straws of other grains the heating value of dry straw ranged from 5590 for buckwheat to 6750 for flax.†

Clark ("Steam-engine," vol. i. p. 62) gives the mean composition of wheat and barley straw as C, 36; H, 5; O, 38; N, 0.50; Ash,

* Journal of the Franklin Institute, 1874.

† *Eng'g Mechanics*, Feb., 1893, p. 55.

4.75; water, 15.75, the two straws varying less than 1%. The total heating value of straw of this composition, according to Dulong's formula, is 5411 heat-units. Clark erroneously gives it as 8144 heat-units. Taking the temperature of the chimney-gases at 462° and that of the air-supply at 62° the "available" heating value is 4660 B.T.U.

Bagasse as Fuel in Sugar Manufacture.—Bagasse is the name given to refuse sugar-cane, after the juice has been extracted. Prof. L. A. Becuel, in a paper read before the Louisiana Sugar Chemists' Association, in 1892, says: "With tropical cane containing 12.5% woody fibre, a juice containing 16.13% solids, and 83.87% water, bagasse of, say, 66% and 72% mill extraction would have the following percentage composition:

| | Woody Fibre. | Combustible Salts. | Water. |
|------------------|-----------------|-----------------------|--------|
| 66% bagasse..... | 37 | 10 | 53 |
| 72% bagasse..... | 45 | 9 | 46 |

"Assuming that the woody fibre contains 51% carbon, the sugar and other combustible matters an average of 42.1%, and that 12,906 units of heat are generated for every pound of carbon consumed, the 66% bagasse is capable of generating 2978 heat-units per pound as against 3452, or a difference of 474 units in favor of the 72% bagasse.

"Assuming the temperature of the waste gases to be 450° F., that of the surrounding atmosphere and water in the bagasse at 86° F., and the quantity of air necessary for the combustion of one pound of carbon at 24 lbs., the lost heat will be as follows: In the waste gases, heating air from 86° to 450° F., and in vaporizing the moisture, etc., the 66% bagasse will require 1125, and the 72% bagasse 1161 heat-units.

"Subtracting these quantities from the above, we find that the 66% bagasse will produce 1853 available heat-units, or nearly 38% less than the 72% bagasse, which gives 2990 units.

"It appears that with the best boiler plants, those taking up all the available heat generated, by using this heat economically the bagasse can be made to supply all the fuel required by our sugar-houses."

Petroleum.—Thos. Urquhart of Russia gives the following table of the theoretical evaporative power of petroleum in comparison with that of coal, as determined by Messrs. Favre and Silbermann:*

* Proc. Inst. M. E., Jan., 1889.

| Fuel. | Specific Gravity at 32° F., Water = 1.000. | Chem. Comp. | | | Heating power, British Thermal Units | Theoret. Evap., lbs. Water per lb. Fuel, from and at 212° F. |
|--|--|-------------|------------|-----------|--------------------------------------|--|
| | | C. | H. | O. | | |
| Penna. heavy crude oil..... | S. G. 0.886 | p. c. 84.9 | p. c. 13.7 | p. c. 1.4 | Units. 20,736 | lbs. 21.48 |
| Caucasian light crude oil .. | 0.884 | 86.3 | 13.6 | 0.1 | 22,027 | 22.70 |
| “ heavy “ “ | 0.938 | 86.6 | 12.3 | 1.1 | 20,138 | 20.85 |
| Petroleum refuse..... | 0.928 | 87.1 | 11.7 | 1.2 | 19,832 | 20.53 |
| Good English coal, mean of 98 samples..... | 1.380 | 80.0 | 5.0 | 8.0 | 14,112 | 14.61 |

In experiments on Russian railways with petroleum as fuel, Mr. Urquhart obtained an actual efficiency equal to 82% of the theoretical heating value. The petroleum is fed to the furnace by means of a spray-injector driven by steam. An induced current of air is carried in around the injector-nozzle, and additional air is supplied at the bottom of the furnace.

The following notes are condensed from a paper on “Crude Petroleum and its Products as Fuel,” by R. H. Tweddle.*

Crude petroleum is a hydrocarbon, often containing a small percentage of sulphur and oxygen as impurities. Its specific gravity may vary from 12° to 70° Baumé, but the greatest quantity produced ranges from 30° to 45° Baumé. The color of crude petroleum is usually a green brown, but it is found from a light brown color, through the various shades of green to a jet black. It may be broken up by distillation into benzene, kerosene, and other distillates and residuums of various qualities, any one of which makes a very good fuel under certain conditions.

Gasoline, or petroleum distillate of more than 74° Baumé, will never be used for fuel except to a very limited extent, since it and its closely associated distillates are always more valuable for other purposes.

Benzene, or petroleum distillate from 55° to 74° Baumé, is the best of all liquid fuels, but its use is restricted owing to the care with which it has to be handled. The difficulty, danger and expense of transporting will only allow of its use in a very few favored localities.

Kerosene or petroleum distillate of from 48° B. to 35° B. gravity is an excellent fuel, but, owing to the expense attending its preparation, we can hardly expect to see the price fall below 3c. per gallon, except in the places where it is produced; for, should it generally be-

* *Engineering and Mining Journal*, Oct. 14, 21, and 28, 1899.

come so cheap the consumption of it as an illuminant would increase so enormously that there would be little left for fuel.

The present price of kerosene in bulk and in large quantity may be taken at about 3c. per gallon at its place of production, both in Russia and America. As a fuel for small boilers, it is the best, because of its portability and the safety and facility with which it can be handled.

Next to kerosene, some of the heavy distillates of petroleum known as neutral or solar oils could be used as fuel, but they have no particular advantage over kerosene, save their high fire-test.

Crude petroleum may contain any portion of benzene and kerosene from nothing up to nearly 90 per cent, varying entirely with the locality where it is produced. We may say roughly that of these two distillates, American crude petroleum contains 50 to 75 per cent of kerosene and benzene; Russian from 15 to 50 per cent; Peruvian from 15 to 50 per cent.

If distillation is stopped after the benzenes and kerosenes have been run off, there remains in the still an oil known by the various names of residuum, reduced oil, tar, fuel-oil, *astatki*, *mazoot*, petroleum refuse, etc.

If the distillation of this residuum is pushed still farther, neutral and lubricating oils distill over, or else, with certain forms of stills, decomposition sets in, and various products may be distilled over, until nothing but a small amount of coke is left in the still.

The demand for mineral lubricating oils is so great in the United States that but little residuum would be placed on the market at a price which would render it available as a fuel-oil. In Russia, however, where the crude oil contains a low percentage of kerosene, there is an enormous surplus of residuum, which cannot all be used for the manufacture of lubricating oils. It is generally known as "*astatki*" or "*mazoot*," and is used for fuel in all possible places. This *astatki* is the fuel-oil par excellence for marine and locomotive work where a perfectly safe oil is required. It is now distributed largely over the Russian Empire, and in 1890 some 600,000 tons were used for interior navigation in Russia alone, and the consumption has been constantly increasing.

The eastern petroleum region of the United States is about 400 miles from the seaboard, and although many pipe-lines traverse this distance, there must be an expense connected with the carriage of the crude oil. The petroleum fuel consumed in the United States is

almost restricted to the use of crude oil, and this is not the fuel which will suit the general consumer, especially if he is to use the oil for either railroad or marine purposes. Crude oil is a most excellent and easily handled fuel, but it must be used with caution, and is absolutely unfit for use on a locomotive or steamer, since, in case of accident, it may catch fire and spread with startling rapidity. For such purposes no petroleum should be used that has a fire-test of less than 200° to 250° Fahrenheit. A petroleum oil with a fire-test of 250° F. is a safer fuel than coal.

Residuum oil which has a fire-test of say 250° to 300° F. is the most suitable for fuel on steamers, since it is absolutely safe, as it cannot take fire and does not give off inflammable gases until heated to a temperature above that of boiling water. As the fuel would be carried in tanks below the water-line, heating to that degree becomes a practical impossibility. Such oil may be placed in a bucket and stirred with a red-hot poker without catching fire; shovelful of hot coals may be thrown into it, but they will sink and be extinguished the same as if thrown in water.

It is probable that in the future petroleum fuel will be used more for marine purposes on account of economy in space and weight. California petroleum will probably be largely used for this purpose, as the production of crude petroleum there is being rapidly increased, and the oil is better suited by its quality for fuel than for refining purposes, owing to the small proportion of volatile constituents and large proportion of heavy hydrocarbons. It is just the contrary with the petroleum found in the Eastern States, which is especially adapted to the manufacture of illuminating oils, owing to the large proportion of volatile hydrocarbons it contains.

The petroleum-fields of Peru somewhat resemble those of California, and are most favorably situated close to the sea. The crude oil is a good fuel for stationary boilers, and, if 40 per cent of benzene and kerosene are distilled off, the resulting residuum is an oil of about 22° B. gravity and 260° to 280° fire-test, of moderate viscosity and containing no paraffine. It preserves its fluidity at low temperatures, and makes an excellent fuel for either locomotive or marine use. The price at which it can be supplied is \$5.00 to \$7.50 per ton. As good coal on the west coast of South America seldom reaches a lower figure than \$6.25 per ton, this fuel-oil will be able to compete with it from an economic point of view so soon as a sufficiently large supply of it is guaranteed.

Some of the advantages claimed for liquid fuel are:

1. Diminished loss of heat up the funnel, owing to the clean condition the tubes can be kept in, and to the smaller amount of air which has to pass through the combustion-chamber for a given fuel consumption.

2. A more equal distribution of heat in the combustion-chamber, as the doors do not have to be opened, and consequently a higher efficiency is obtained.

3. With oil there is no chance of getting dirty fires on a hard run, as with coal.

4. A reduction in cost of handling fuel, since in one case it is all done mechanically or by gravitation, while with solid fuel a great deal of manual labor is required.

5. No firing tools or grate-bars are used, consequently the furnace lining and brickwork floors, etc., suffer less damage.

6. No dust nor ashes to cover or fill the tubes and diminish the heating surface, nor to be handled or carted away.

7. Petroleum does not suffer while being stored, while the deterioration of coal under atmospheric influence is well known.

8. Ease with which fire can be regulated, from a low to a most intense heat in a short time.

9. Absence of sulphur or other impurities and longer life of plates, etc.

10. Lessening of manual labor to fireman.

11. Great increase of steaming capacity, as was conclusively proved when many factories returned to coal in Pennsylvania and Ohio; they had to increase their boiler capacity about 35 per cent.

The coal consumption of the world is probably in the neighborhood of 600,000,000 tons per annum, while that of petroleum is only about 17,000,000 tons, of which by far the greatest part is used for illuminating or lubricating purposes; so the amount of petroleum available for fuel purposes is probably not more than 1 per cent of the coal used. Liquid fuel will therefore never be used very extensively as compared with coal, but where it is used it will have many advantages over the solid fuel. On vessels of war, and especially torpedo-boats, it would give the very best results if used intelligently.

Oil vs. Coal as Fuel.—A test by the Twin City Rapid Transit Company of Minneapolis and St. Paul showed that with the ordinary Lima oil weighing $6\frac{6}{10}$ pounds per gallon, and costing $2\frac{1}{4}$ cents per gallon, and coal that gave an evaporation of $7\frac{1}{2}$ lbs. of water per pound of coal,

the two fuels were equally economical when the price of coal was \$3.85 per ton of 2000 lbs. With the same coal at \$2.00 per ton, the coal was 37% more economical, and with the coal at \$4.85 per ton, the coal was 20% more expensive than the oil. These results include the difference in the cost of handling the coal, ashes, and oil.*

In 1892 there were reported to the Engineers' Club of Philadelphia some comparative figures, from tests undertaken to ascertain the relative value of coal, petroleum, and gas.

| | Lbs. Water, from and at 212° F. |
|---------------------------------------|------------------------------------|
| 1 lb. anthracite coal evaporated..... | 9.70 |
| 1 lb. bituminous coal..... | 10.14 |
| 1 lb. fuel oil, 36° gravity..... | 16.48 |
| 1 cubic foot gas, 20 C. P. | 1.28 |

The gas used was that obtained in the distillation of petroleum, having about the same fuel value as natural or coal-gas of equal candle power.

Taking the efficiency of bituminous coal as a basis, the calorific energy of petroleum is more than 60% greater than that of coal; whereas, theoretically, petroleum exceeds coal only about 45%—the one containing 14,500 heat-units, and the other 21,000.

Comparative tests of crude petroleum and of Indiana block coal for steam-raising at the South Chicago Steel Works† showed that, with coal, 14 tubular boilers 16 ft. × 5 ft. required 25 men to operate them; with fuel oil, 6 men were required, a saving of 19 men at \$2 per day, or \$38 per day.

For one week's work 2731 barrels of oil were used, against 848 tons of coal required for the same work, showing 3.22 barrels of oil to be equivalent to 1 ton of coal. With oil at 60 cents per barrel and coal at \$2.15 per ton, the relative cost of oil to coal is as \$1.93 to \$2.15. No evaporation tests were made.

Gas Fuel.—Natural gas is an ideal fuel for steam-boilers wherever it can be obtained in sufficient quantity and at reasonable cost as compared with coal. About 1890 it was in quite general use in western Pennsylvania and in many places in Ohio and Indiana, when numerous wells furnished vast quantities of gas at a high pressure, but in a few years the supply diminished and it became too high in

* *Iron Age*, Nov. 2, 1893.

† *Trans. A. I. M. E.*, xvii, p. 807.

price to be commonly used in steam-boilers. Its use is now confined chiefly to household purposes. The following are some analyses:*

NATURAL GAS IN OHIO AND INDIANA.

| Description. | Ohio. | | | Indiana. | | | |
|---------------------|------------|-----------|-------------|----------|------------|----------|---------|
| | Fos-toria. | Find-lay. | St. Mary's. | Muncie. | Ander-son. | Koko-mo. | Marion. |
| Hydrogen..... | 1.89 | 1.64 | 1.94 | 2.35 | 1.86 | 1.42 | 1.20 |
| Marsh-gas..... | 92.84 | 93.35 | 93.85 | 92.67 | 93.07 | 94.16 | 93.57 |
| Olefiant gas..... | .20 | .35 | .20 | .25 | .47 | .30 | .15 |
| Carbon monoxide.... | .55 | .41 | .44 | .45 | .73 | .55 | .60 |
| Carbon dioxide..... | .20 | .25 | .23 | .25 | .26 | .29 | .30 |
| Oxygen..... | .35 | .39 | .35 | .35 | .42 | .30 | .55 |
| Nitrogen..... | 3.82 | 3.41 | 2.98 | 3.53 | 3.02 | 2.80 | 3.42 |
| Hydrogen sulphide.. | .15 | .20 | .21 | .15 | .15 | .18 | .20 |

Approximately 30,000 cubic feet of gas has the heating power of one ton of coal.

Producer-gas.—Since the invention of the Siemens producer and regenerative furnace, in 1856, and their general introduction into metallurgical and glass works, many attempts have been made to use producer-gas as a fuel for steam-boilers, the evident advantage being the ease of conveying the gas in pipes from a centrally-located producer-plant to a number of boilers, the facility of operation of the boilers with gaseous fuel, and the saving of labor. These attempts have generally failed, however, on account of the facts that the gas-making process always entailed some loss of heat, that the producers were of too great cost, and that it was difficult to drive them at the varying rates usually required in steam-boiler practice. The following analysis of producer-gas is given by W. H. Blauvelt: †

PRODUCER-GAS FROM ONE TON OF COAL.

| Analysis by Volume. | Per Ct. | Cubic Feet. | Pounds. | Equal to— |
|-------------------------------------|---------|-------------|---------|---|
| CO..... | 25.3 | 33,213.84 | 2451.20 | 1050.51 lbs. C + 1400.7 lbs. O. |
| H..... | 9.2 | 12,077.76 | 63.56 | 63.56 " H. |
| CH ₄ | 3.1 | 4,069.68 | 174.66 | 174.66 " CH ₄ . |
| C ₂ H ₄ | 0.8 | 1,050.24 | 77.78 | 77.78 " C ₂ H ₄ . |
| CO..... | 3.4 | 4,463.52 | 519.02 | 141.54 " C + 377.44 lbs. O. |
| N (by difference).. | 58.2 | 76,404.96 | 5659.63 | 7350.17 " Air. |
| | 100.0 | 131,280.00 | 8945.85 | |

Calculated upon this basis, the 131,280 ft. of gas from the ton of coal contained 20,311,162 B.T.U., or 155 B.T.U. per cubic foot, or 2270 B.T.U. per lb.

* *Engineering and Mining Journal*, April 21, 1894.

† *Trans. A. I. M. E.*, xviii. p. 614.

The composition of the coal from which this gas was made was as follows: Water, 1.26%; volatile matter, 36.22%; fixed carbon, 57.98%; sulphur, 0.70%; ash, 3.78%. One ton contains 1159.6 lbs. carbon and 724.4 lbs. volatile combustible, the energy of which is 31,302,200 B.T.U. Hence, in the processes of gasification and purification there was a loss of 35.2% of the energy of the coal.

The following table of comparative analyses and heating values of different kinds of gas is given by W. J. Taylor:*

| | Natural Gas. | Coal-gas. | Water-gas. | Producer-gas. | |
|-------------------------------------|--------------|-----------|------------|---------------|----------|
| | | | | Anthra. | Bitumin. |
| CO..... | 0.50 | 6.0 | 45.0 | 27.0 | 27.0 |
| H..... | 2.18 | 46.0 | 45.0 | 12.0 | 12.0 |
| CH ₄ | 92.6 | 40.0 | 2.0 | 1.2 | 2.5 |
| C ₂ H ₄ | 0.31 | 4.0 | | | 0.4 |
| CO ₂ | 0.26 | 0.5 | 4.0 | 2.5 | 2.5 |
| N..... | 3.61 | 1.5 | 2.0 | 57.0 | 56.2 |
| O..... | 0.34 | 0.5 | 0.5 | 0.3 | 0.3 |
| Vapor..... | | 1.5 | 1.5 | | |
| Pounds in 1000 cubic feet... | 45.6 | 32.0 | 45.6 | 65.6 | 65.9 |
| Heat-units in 1000 cubic feet | 1,100,000 | 735,000 | 322,000 | 137,455 | 156,917 |

Corn as Fuel.—It is quite common in Nebraska, in years when the corn crop is abundant and selling prices low, to use corn instead of coal as fuel. Prof. C. R. Richards reports in *Cassier's Magazine* the results of two boiler tests, one with corn and one with good Rock Springs bituminous coal, costing in Lincoln, Neb., \$6.65 per ton. The results showed that the coal gave 1.9 times as much heat per lb. as the corn. Tests of both fuels in a fuel calorimeter gave 7076 B.T.U. for the corn, and 13,010 for the coal, a ratio of 1 to 1.86. Other calorimeter tests of different sample of corn gave results as follows:

THE HEATING VALUE OF CORN.

| Kind of Material. | Heating Value in B.T.U. | | |
|-------------------------------|-------------------------|--------------------------|-----------------------------|
| | Per lb. of Material. | Per lb. of Dry Material. | Per lb. of Dry Combustible. |
| Yellow Dent corn and cob..... | 8040 | | |
| Yellow Dent corn..... | 8202 | 8959 | 9085 |
| Yellow Dent cob..... | 7214 | 7841 | 7958 |
| White Dent corn and cob..... | 7841 | | |
| White Dent corn..... | 8382 | 9199 | 9301 |
| White Dent cob..... | 7571 | 8174 | 8285 |

Assuming the average heating value of Nebraska coal at 11,500 B.T.U. per lb., that of corn 8040 B.T.U., and the weight of corn 56 lbs. per bushel, corn at 10 cents per bushel would be as cheap a fuel as coal at \$5.11 per ton of 2000 lbs.

* Trans. A. I. M. E., xviii. p. 205.

CHAPTER VII.

FURNACES. — METHODS OF FIRING. — SMOKE-PREVENTION. — MECHANICAL STOKERS.—FORCED DRAFT.

Location of the Furnace.—The furnace, or fire-box, of a steam-boiler should be considered as an apparatus separate and distinct from the boiler itself. The function of the furnace is to generate heat by the combustion of the fuel; that of the boiler is to transfer the heat into the water. The combustion-chamber, when there is one, is an extension of the fire-box; its office is to afford space in which to complete the combustion of the volatile gases which are imperfectly burned in the fire-box.

In internally fired boilers, such as the locomotive, marine, Lancashire, and vertical tubular boilers, the fire-box is located inside of the boiler. The chief advantage of this method of construction is its economizing of space, but it is attended with the disadvantages of limiting the area of grate-surface, and thereby limiting the coal-burning capacity of the boiler, and, with soft coal, of providing insufficient space for a combustion-chamber, in which to burn the volatile gases. Another objection to the internal furnace is usually that the walls of the fire-box and combustion-chamber are metallic surfaces, kept comparatively cool by the water in the boiler, which chill the gases and tend to prevent their combustion. In some such furnaces, however, fire-brick arches or walls are used, which have the beneficial effect of keeping the furnace at a high temperature.

With other types of boilers, such as the horizontal tubular and the common form of water-tube boiler, with inclined tubes, it is customary to locate the furnace immediately underneath the boiler, between the brick walls of the setting. For horizontal tubular boilers this method of setting is usually satisfactory, for the width between the side-walls of the setting is sufficient to accommodate an ample area of grate-surface, on which may be burned, at moderate rates of combustion, all the coal that should be burned for the amount of heating surface of

the boiler. When soft coal is used this setting allows of a long travel of the gases, which is favorable to their combustion, and furthermore, it furnishes sufficient space in which to build fire-brick arches, baffle-walls, or other devices to more perfectly secure complete combustion.

With water-tube boilers of the inclined-tube form, this location is unobjectionable when large sizes of anthracite coal are used; in this case the grate-surface is sufficiently large to burn with moderate draft all the coal that is required to develop the full economical capacity of the boiler, and the small quantity of volatile gases is easily burned in the fire-box. With small sizes of coal this setting does not provide sufficient space for grate-surface enough to develop the usual rated capacity of the boiler, unless a very strong draft is provided either by a tall chimney or by mechanical means. The fine sizes of anthracite usually contain a considerable percentage of moisture, which forms combustible gas by its decomposition by red-hot carbon, some of which gas is apt to escape unburned unless abundant room is provided for burning it in the fire-box.

For bituminous coal the ordinary setting of an inclined water-tube boiler, with the gas-passages rising immediately above the furnace into the nest of tubes above, is entirely unsuitable. There is insufficient room in the furnace for the burning of the gases; they are chilled by the water-tubes above the furnace; they deposit soot upon them, diminishing the effectiveness of the heating surface, and a large proportion of the gas escapes unburned. A furnace which provides a long travel of the gases under a fire-brick roof, before they are allowed to enter the nest of tubes, such as the setting of the Heine boiler, is an improvement in this respect, but such a furnace is not well adapted to boilers having more than seven horizontal rows of tubes, for in this case the gas-passage along the tubes is of too large an area in cross-section to cause the current of hot gas to completely envelop all the tubes, and it therefore allows of "short-circuiting," rendering some of the heating surface ineffective.

External fire-brick furnaces, commonly called "Dutch ovens," are used with the vertical types of water-tube boilers, and to some extent with the inclined-tube boilers, with great advantage. When properly designed they admit of sufficient areas of grate-surface, and of the use of deflecting arches, baffle-walls, etc., for insuring combustion of the gases.

Requirements of a Good Furnace.—(1) It should have ample coal-burning capacity. It should be able to burn the amount of coal

needed to generate the maximum quantity of steam that may be required during any hour of the day, under the most unfavorable conditions that may be expected, such as atmospheric or other conditions tending to diminish the chimney draft, and coal of a poorer quality than is usually furnished.

(2) The grates should be of such a kind that ash and clinker may be easily removed from them without stopping the operation of the boiler for more than a few minutes at a time, and the bars should be so spaced that coal is not apt to be wasted by falling through them.

(3) It should be so constructed as to be capable of burning thoroughly all of the gases that may be distilled from the fuel before they come in contact with the comparatively cool heating surfaces of the boiler.

(4) It should be durable, free from breakdowns of coal-feeding appliances or shaking grates, and from melting down of fire-brick arches.

(5) Furnaces of externally fired boilers should be built with thick walls, so as to minimize as far as possible loss of heat by radiation, or preferably with double walls with air-spaces between. The air-spaces may with advantage be so arranged as to cause a current of air to flow through them into the ash-pit or above the fire.

Burning of Anthracite Coal.—For large sizes of anthracite, such as egg, almost any kind of furnace is suitable, and no great degree of skill is needed to fire the coal so as to obtain the best results. With all ordinary proportions of grate and heating surface a moderate draft suffices to burn enough coal to drive the boiler up to and beyond its economical rating. Hand-firing is always used with this coal, and all that the fireman needs to do is to keep a level bed of coal on the grate of a depth proportionate to the force of the draft, to watch carefully to prevent the formation of air-holes in the bed of coal, and to clean the fire at long intervals of time, say from six to ten hours. When there is plenty of draft the fireman has control of two factors governing the combustion, viz., the damper and the thickness of the bed of coal, which he can regulate at his pleasure. With a given force of draft, which may be controlled by the damper, if the bed of coal is too thin an excessive supply of air passes through it, causing a waste of heat in the chimney gases; if it is too thick some of the carbon will be burned only to carbon monoxide, instead of to carbon dioxide, causing a great loss of heat. The latter source of loss, when there is sufficient draft available, may easily be prevented, for it makes itself known by a sluggish action of the fire, the presence of blue flames on

the bed of coal, and low temperature of the furnace. The remedy is either to carry a thinner bed of fire, or to open the damper and give a stronger draft in the furnace. The loss due to excess of air on account of too thin a bed of coal is much more common, and its effect in the furnace is not so apparent to the fireman. It may be prevented by carrying as thick a bed of coal as will not cause the temperature of the furnace to be visibly lowered and blue flames to make their appearance.

In all cases the highest possible temperature of the furnace gives the highest economy, provided the heating surface is of sufficient extent to absorb the proper proportion of the heat generated, and to cool the gases to the lowest practicable temperature before they reach the chimney-flue. The highest temperature is obtained by firing small quantities of coal at a time and by keeping the bed of coal at such a thickness as will insure complete combustion without an excessive supply of air passing through it.

With small sizes of anthracite there is more difficulty in securing the best conditions of combustion. The fineness of the coal tends to choke the air-passages through the bed on the grate, and a thinner bed has therefore to be carried unless there is a very strong draft, and a thin bed is more difficult than a thick one to keep free of air-holes. The coal is usually much higher in ash than large-sized coal, and the fires therefore need to be cleaned oftener—an operation which always chills the fire, decreases the rate of steaming, and causes a waste of heat. The evaporation per pound of combustible with fine sizes of coal is usually in ordinary practice considerably less than with egg coal.

In order to burn a sufficient quantity of fine sizes of anthracite coal to develop the required capacity of a boiler it is common to use a forced blast provided either by a fan or by a steam-jet.

Burning Small Sizes of Anthracite.—The report of the Pennsylvania State Commission on “Waste of Coal Mining,” 1883, contains the following:

A number of experiments were made in the testing laboratory of Coxe Bros. & Co., by Mr. John R. Wagner, in burning small coals with a forced draught, obtained in one case by a fan and in the other by a steam-jet. They showed:

“*First.*—That the ashes produced by a steam-jet were never as low in carbon as those produced by the fan; that is, an appreciably larger per cent of the carbon was utilized by the fan-blast. This appears to be due to the fact that when the carbon in the ash over the grate is reduced to a certain point the steam dampens it somewhat, and it ceases to burn sooner than it does when dry air only is blown through it.

“*Second.*—That with the fan-blast the rate of combustion per square foot per hour is greater than with the steam-jet.

“*Third.*—It was found that where a bed of coal was ignited and burned out, the percentage of carbon in the ash is much less than where coal is successively added to the burning mass. In practice it is not generally possible to allow the bed to burn out sufficiently before adding the cold, unignited coal; the result is a damping down of the fire, which causes the ash to cease burning sooner than it would do if there were no reduction of temperature and checking of the draught due to the adding of the coal.

“*Fourth.*—There seems to be no doubt that the introduction of steam into the ash-pit decreases very materially the tendency of the coal to clinker on the grate in comparison with the fan-blast or natural draught. It also changes the color, volume, and character of the flame, and, owing to producer action, increases the distance that the flame extends beyond the bridge-wall. In many cases it is not practical, or at least it is very difficult, to fire the smaller sizes of coal without the steam-jet on account of the clinkering. This effect of steam on clinkering is probably due to the fact that the steam, to a certain extent, moistens the ash close to the grate and prevents the ash from reaching there as high a temperature as it would with dry air. It is also probable that the decomposition of the steam into carbonic oxide and hydrogen, which takes place to a certain extent, and which, of course, is accompanied by a reduction of temperature, tends to prevent clinkering. The decomposition of the steam, accompanied by the formation of carbonic oxide and hydrogen, will probably account for the difference in the flame referred to.

“*Fifth.*—A careful study of the burning of culm, that is, the burning of small coals with more or less dust in them, in these and other experiments, seemed to show that in almost all cases it is accompanied by a very high percentage of carbon in the ash, which analysis showed, in some cases, reached 58 per cent. Unless special precautions are taken to prevent it, a large portion of the fine coal runs down through the grate. When the culm gets red hot it acts almost like dry sand and works its way into the ash-pit, thus increasing largely the percentage of carbon. Where coal has to be transported any distance, the value of the culm at the mines being very small, it is probable, from the investigations made, that it would be cheaper to remove the dust and transport only the larger coal.

“*Sixth.*—It has been found that the percentage of iron pyrites, which occurs to a greater or less extent in all coals, increases very rapidly with the smallness of the coal. This is due to the fact that the iron pyrites occur generally in thin layers or in incrustations on the coal. These thin layers are broken off and pulverized in the preparation and handling of the coal, and are therefore found to a much greater extent in the very small coal. It is, of course, well known that the presence of iron pyrites in fuel is very undesirable, as it generates sulphurous acid and has a tendency to destroy the grates

or other iron-work around the boilers, besides, in many cases, increasing the tendency to clinker.

“*Seventh.*—That while the fan-blast produces the best ash and gives a more perfect and greater rate of combustion, yet in many cases it is more advantageous to use the steam-blower on account of the clinkering, which may cause very serious trouble. In certain localities, particularly in cities, the noise of the steam-blower is sometimes a disadvantage.

“*Eighth.*—While it is not positively demonstrated, it is thought that the question of mixing small coals from different veins of different localities is a matter of importance. It would appear that sometimes two coals, each of which, when burned separately, give reasonably satisfactory results, when mixed together, clinker and give trouble, probably because the ash of the combined coals forms a much more fusible silicate than either of the ashes separately.

“*Ninth.*—It would seem that the combustion of the small anthracite is more perfect when the coal remains undisturbed, or as nearly as possible in the condition in which it was put in the fire, instead of being turned over so that the partially consumed and the unconsumed coal are mixed together.”

Comparative Efficiency of Steam- and Fan-blowers.—The following record of comparative tests of steam- and fan-blowers, made on three

| Dimensions of boilers.....36 in. diam., 42 ft. long. Area grate-surface, 3 boilers.....61.5 sq. ft. | With Steam-blower. | With Fan-blower. |
|--|--------------------|------------------|
| COAL. | | |
| Total coal burned (less moisture)..... | 7,700 lb. | 6,100 lb. |
| “ ash..... | 1,330 “ | 1,027 “ |
| “ combustible..... | 6,370 “ | 5,073 “ |
| Per cent of ash..... | 17.2 per cent | 16.8 per cent |
| Coal burned per hour..... | 962.5 lb. | 762.5 lb. |
| Combustible burned per hour..... | 796.3 “ | 634.1 “ |
| WATER. | | |
| Total water evaporated, actual conditions..... | 39,241 lb. | 34,890 lb. |
| Equivalent water evaporated per hour from and at 212°..... | 5,444 “ | 4,867 “ |
| Water evaporated per hour per lb. of coal, actual conditions... .. | 5.10 “ | 5.59 “ |
| “ “ “ “ “ “ “ coal from and at 212°..... | 5.66 “ | 6.38 “ |
| “ “ “ “ “ “ “ combustible from and at 212°..... | 6.84 “ | 7.67 “ |
| H. P. developed..... | 157.81 “ | 141.1 “ |
| Average boiler pressure..... | 77 “ | 78 “ |
| Average temperature of feed-water..... | 134° | 137° |
| BLOWERS. | | |
| Boiler H. P. used by blowers per hour from and at 212°..... | 11.9 H. P. | 5.64 H. P. |
| Per cent of the developed H. P. of the three boilers used for blowers..... | 7.4 per cent | 4 per cent |
| Cubic feet of air per minute..... | 2,502 ft. | 3,506 ft. |
| Average water-gauge..... | .44 in. | .52 in. |
| Horsepower in air..... | 0.173 H. P. | 0.28 H. P. |

REMARKS.—In the test with the fan-blower, the exhaust from the fan-engine was turned into the air-current and found sufficient to keep the grates free from clinker.

| | |
|--|------------|
| Average steam-pressure at steam-blowers..... | 74 lb. |
| “ I. H. P. of fan-engine..... | 1.62 H. P. |
| “ No. of revolutions of fan-engine..... | 160 revs. |
| “ “ “ “ “ fan..... | 915 “ |
| Useful effect of fan..... | 17% |

plain cylinder boilers at the Short Mountain Colliery, Lykens, Pa., was published in the *Colliery Engineer*, August, 1897. The conditions in each case were the same, rice coal being used as fuel on a sectional grate with 12 per cent air-openings.

The fan-blower consisted of a gangway-fan 33 in. diam., 4 paddles $9 \times 9\frac{1}{2}$ in., driven by a small slide-valve engine with cylinder $4\frac{1}{8}$ in. diam., $7\frac{3}{4}$ in. stroke. Steam was supplied by a small upright boiler on which an evaporative test was run during the test on the cylinder boilers.

The steam-blower was made of $\frac{3}{4}$ -in. pipe, circle $6\frac{3}{4}$ in. diam., 16 holes, tapered $\frac{1}{8}$ in. outside, $\frac{1}{16}$ in. inside, diam. Steam was supplied by the upright boiler on which a test was run as above. Duration of each test, 8 hours.

The saving of fuel by the use of the fan-blower, as compared with the steam-blower, was 13.9 per cent, taking into account the steam used by each blower.

Grate-bars.—Two styles of grate-bars in common use are shown in Figs. 12 and 13. The first is a plain cast-iron bar, tapered in cross-section, so as to make a wider opening between the bars at the lower than at the upper edge. Projections are cast on the sides of the bars to keep them at the proper distance apart. The second is channel-



FIG. 12.

shaped in cross-section, with the upper surface provided with V-shaped openings. The total area of the air-spaces is usually made from 30 to 50 per cent of the total area of the grate-surface. The width of the air-spaces and of the bars or ribs differs according to the

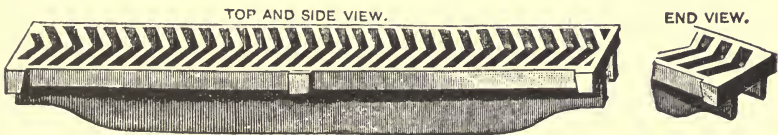

FIG. 13.

size and kind of coal used. For fine sizes of anthracite the spaces are made as narrow as $\frac{3}{8}$ inch. For large sizes of anthracite and for "run-of-mine" soft coal they are often made as wide as 1 inch. When the ash of the coal tends to form clinkers, narrow air-spaces are objection-

able, as they are apt to become clogged, and are difficult to keep open so as to allow a sufficient supply of air to pass through them.

The resistance to the passage of air through the grate and the bed of coal lying upon it depends upon other things besides the size of the air-spaces in the grate, such as the size of the coal, its quality as regards coking or non-coking, the thickness of the bed of coal and ashes, the presence or absence of clinker, etc. With coals that are low in ash, and the ash non-clinkering, it is possible to burn the coal with very narrow air-spaces through the grates.

Fine sizes of anthracite are sometimes burned on flat cast-iron plates perforated with tapering holes about $\frac{1}{2}$ inch diameter at the upper surface, the total air-space being about 25 per cent of the grate-area.

Mr. F. A. Scheffler * reports a test in which grate-bars of the form shown in Fig. 13 were used, with the air-spaces only about $\frac{1}{4}$ inch wide, and the total area of air-space only about 15 per cent of the grate-surface. The coal was Pittsburg run-of-mine. With a draft pressure of 0.46 in water column, the rate of combustion was 24.8 lbs. of coal per sq. ft. of grate per hour, a rate sufficient to drive the boiler to much above its rated capacity.

On the other hand, the author once made a test with Illinois coal containing a large percentage of sulphur, with bars of the same type, the air-spaces being $\frac{1}{2}$ inch in width and with a draft of 0.4 to 0.5 inch, but was unable to maintain, even with the maximum draft, a rate of combustion sufficient to develop the rated capacity of the boiler. In this case the ash fused into a glass, which ran into and choked the air-spaces.

Shaking- and Dumping-grates.—With coals of the character just described, shaking- or dumping-grates are almost a necessity, unless mechanical stokers are used in preference. Many different forms of such grates are in the market. They may be divided into three general classes: 1. Shaking- or Rocking-grates; 2. Dumping-grates; 3. Shaking- and Dumping-grates. In the first class the bars are usually divided into small sections, which, by means of rocking-bars and levers, are given an oscillatory or reciprocating motion, which causes the ash to fall through between the sections. In the second class the sections are made larger, and when the fires are to be cleaned from clinker the sections, or a part of them, such as those covering one-quarter of the whole grate-area, are rocked from a horizontal into

* Trans. A. S. M. E., vol. xv. p. 503.

a vertical position, thus breaking up the clinker and allowing it to fall through the large openings thus made. In the third class the sections are provided with mechanism by which either the shaking or the dumping motion may be given at will. For non-clinkering coals the first and third classes are used, and for clinkering coals the second and third.

The use of shaking-grates usually entails a loss of some unburned coal through the grates, amounting, with the most careful handling, to from 1 to 3 per cent of the total coal used; but this loss is often more than offset by the gain due to the more complete combustion which is obtained when the air-supply is unrestricted by ash and clinker.

The McClave Grate is shown in Fig. 14. The rear section is shown

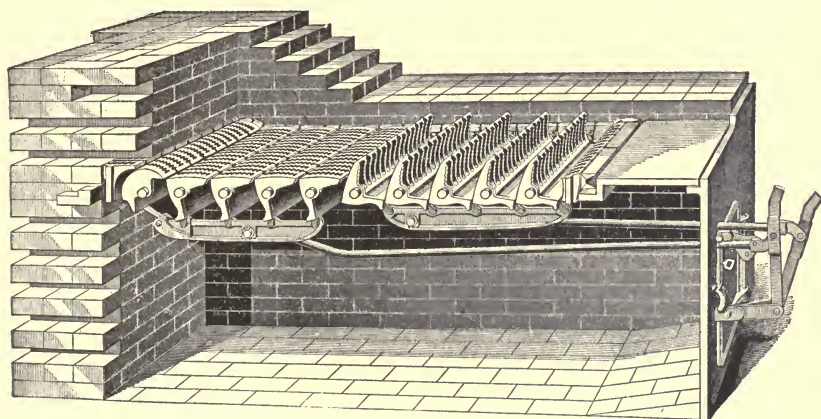

FIG. 14.—THE McCLAVE GRATE.

in the usual position. The front section is shown with the bars tilted up for breaking the clinker.

Each row or section of grate-bars is divided into a front and rear series by means of two separate connecting-bars, operated by twin stub-levers and connecting-rods, with an operating handle adapted to grasp either one or both of the levers in such a manner that the front and rear series may be operated separately or together. This provides for cleaning out the worst kind of clinkers without wasting the unconsumed fuel on the surface, as that may be shoved over on the stationary part while the clinkers and ashes of the other series are being cut through into the ash-pit.

The McClave grate is extensively used for burning buckwheat, birdseye, and other fine sizes of anthracite coal. It is also used in the

coal regions for burning culm or the refuse of the mines. Concerning the use of culm as fuel the circular of the manufacturers of the McClave grate says:

“In the anthracite coal-fields the waste product of the mines, commonly called culm, has proved to be a most excellent fuel for steam purposes and is now being successfully used by the largest manufacturers and producers in the coal region. The cost of this fuel at the mines is merely nominal, but in order to burn it successfully it should contain at least 50 per cent of buckwheat and should be fresh from the mine, for when the buckwheat is nearly all screened out of it, or when it has been exposed to the weather for any considerable length of time, it is comparatively worthless as fuel. Again, it will not pay to ship it any great distance, as the freight on culm is just as much per ton as it is on buckwheat coal, which, for steam purposes, is a much better fuel than culm, and costs at the mine only from 30 to 35 cents per ton more than culm.”

The **Argand Steam-blower**, shown in Figs. 15 and 16, is commonly used in connection with the McClave grate. It delivers a large volume of air, mixed with steam, under the grate. The steam is delivered to the blower through a metal ring, perforated with small holes on the edge nearest to the ash-pit.

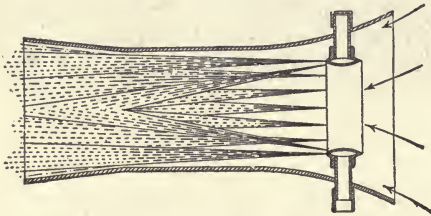

FIG. 15.

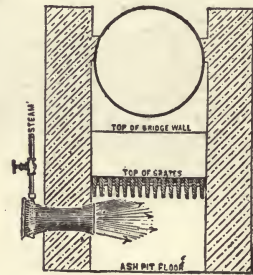

FIG. 16.

current of air which is blown under the grate. While the use of a steam-jet is usually the most wasteful method of producing draft, it has certain advantages over a dry-air blast for the burning of cheap coals high in ash. The decomposition of the steam into oxygen and hydrogen by the hot carbon in the bed of coal is a cooling process, which tends to prevent the formation of clinker on the grates. The heat absorbed by this decomposition is again generated when the gases are burned in the fire-chamber above the grate, so that the only losses due to the use of steam are the cost of the steam itself and the heat required to superheat it to the temperature of the chimney gases.

How to Burn Soft Coal.—Of all known methods of burning soft coal the worst is the one which is most commonly practised, viz.: that of burning it in a common furnace, consisting of a set of grate-bars and a space of contracted dimensions between them and the heating surface of the boiler, the coal being fed by hand. This method is suitable for anthracite coal, the smaller sizes containing much surface moisture perhaps excepted, but when used for bituminous coal it is objectionable both on account of smoke and on account of loss of economy. The objections to the method increase the farther we go west from the anthracite coal-fields of Pennsylvania, being least with the semi-bituminous coals of Pennsylvania, Maryland, and Virginia, and increasing as we go westward and find the percentages of moisture and of volatile matter both increasing.

Objections to the Common Method.—The reasons for the difficulty in obtaining high economy from the bituminous coals when hand-fired in ordinary furnaces may perhaps be understood if we consider the sequence of events that take place between two consecutive firings, at an interval of, say, five or ten minutes apart. Suppose that just before firing fresh coal an intensely hot bed of coke, say 6 inches deep, is lying upon the grate-bars. Half a dozen shovelfuls of coal, much of it of fine size, are spread evenly over the bed. The first thing that the fine fresh coal does is to choke the air-spaces existing through the bed of coke, thus shutting off the air-supply which is needed to burn the gases produced from the fresh coal. The next thing is a very rapid evaporation of moisture from the coal, a chilling process, which robs the furnace of heat. Next is the formation of water-gas by the chemical reaction, $C + H_2O = CO + 2H$, the steam being decomposed, its oxygen burning the carbon of the coal to carbonic oxide, and the hydrogen being liberated. This reaction takes place when steam is brought in contact with highly heated carbon. This also is a chilling process, absorbing heat from the furnaces. The two valuable fuel-gases thus generated would give back all the heat absorbed in their formation if they could be burned, but there is not enough air in the furnace to burn them. Admitting extra air through the fire-door at this time will be of no service, for the gases being comparatively cool cannot be burned unless the air is highly heated. After all the moisture has been driven off from the coal, the distillation of hydrocarbons begins, and a considerable portion of them escapes unburned, owing to the deficiency of hot air, and to their being chilled by the relatively cool heating surfaces of the boiler. During all this time great volumes

of smoke are escaping from the chimney, together with unburned hydrogen, hydrocarbons, and carbonic oxide, all fuel-gases, while at the same time soot is being deposited on the heating surface, diminishing its efficiency in transmitting heat to the water. At length the distillation of the hydrocarbons proceeds at a slower rate, the very fine coal which at first obstructed the air-supply is partially burned away, sufficient hot air comes through the bed of hot coke to burn thoroughly all the gases, and such a balance of conditions between the amount of gas generated and the amount of air supplied exists that the best possible conditions for maximum economy are obtained and the chimney-gases are then smokeless. Finally the gases are all distilled, and a bed of coke remains, which, as long as it is thick enough with relation to the air-supply, will burn under good conditions for economy, but as soon as it burns down low and the air-spaces become large enough to allow an excessive supply of air into the furnace, a new condition of poor economy is reached, the excess of air passing up the chimney carrying away heat which should have been utilized in the boiler.

The waste of fuel is not the only loss occasioned by the prevalent wrongful method of burning soft coal. In all western cities the depreciation in value of residence property in the vicinity of factories, the cost of painting and repainting of houses and stores, the constant scrubbing and washing to remove soot, and the destruction of textile fabrics, if they could all be expressed in dollars and cents, would amount to an enormous total.

Smoky Chimneys not Necessary.—All of the loss due to smoky chimneys it is quite possible to avoid, by the use of well-known and well-tried appliances. The principles which govern the complete and smokeless combustion of bituminous coal are simple enough, but the application of these principles in practice has hitherto been usually considered to involve extra cost of installation of a boiler plant, extra cost of repairs, and extra trouble. The fear of extra cost and trouble, together with exceeding conservatism of factory owners in regard to everything connected with steam-boilers, have been the chief obstructions to the universal use of smokeless furnaces in our western States. These obstructions are, however, rapidly being removed. Many large concerns have recently introduced smokeless furnaces, not to abate a nuisance, but to save fuel and labor, and within a very few years it may be expected that their use will be almost universal in large boiler plants.

How to Avoid Smoke.—Coal can be burned without smoke, provided:

I. The gases are distilled from the coal *slowly*.

II. That the gases when distilled are brought into intimate contact with *very hot* air.

III. That they are burned in a hot fire-brick chamber.

IV. That while burning they are not allowed to come in contact with comparatively cool surfaces, such as the shell or tubes of a steam-boiler; this means that the gases shall have sufficient space and time in which to burn before they are allowed to come in contact with the boiler surfaces.

Practical Success of Smoke-prevention.—Mr. Alfred E. Fletcher, Chief Inspector of the Local Government Board in Scotland, in his report for 1892, says :

“This problem of combating the smoke nuisance must be carried on like other struggles by attacking the weaker part first, and in this case it is the black part of the smoke. Although this part of the problem is not easy, yet it is possible of solution, and has been in many ways successfully attacked as far as the smoke of factories is concerned.

“In my report for the year 1888, I gave an account of experiments undertaken in this cause. I there detailed the result of the examination of the smoke from 52 furnaces taken in different parts of the country, where various kinds of coal were burnt, and in different forms of furnace. The analyses of the gases of combustion showed that there were great differences in the proportions of air admitted, and that in all cases, even where the smoke was blackest, there was an excess of air. That the imperfection of the combustion did not arise from want of air in the fire, but from a misuse of it. It is obvious that unless the air is mixed with the carbonaceous gases, combustion is impossible, and also unless that mixture is maintained at a sufficiently high temperature. In short, as has been often pointed out, there must be, firstly, a sufficiency of air; secondly, that air must be brought into contact with the fuel, both solid and gaseous, and thirdly, the mixture of the gases and the air must be maintained for a sufficient time at a temperature of incandescence. These conditions are simple, but the necessity of providing them is not always kept in view. . . . It would be unsuitable here to mention the names of the numerous makers of these appliances, but it may with confidence be asserted that consumers of coal in almost all kinds of furnaces have it now in their power to conform with the requirements of the Public Health Act, and prevent the discharge of black smoke from their chimneys. As a proof of this, one prominent instance can be mentioned of a large chemical works, where may be seen a row of 50 large Lancashire boilers, each with two furnaces, and an equal number of furnaces applied to other purposes than that of raising steam, making in all as many as 200 fires. Till lately a row of four chimneys poured out a mass of

black smoke, which shrouded the whole district in its pall; now they are smokeless as far as color is concerned, and only fully burnt colorless gases are sent into the air.”

Requirements of a Smoke-preventing Furnace.—A committee appointed by the Engineers' Club of St. Louis in 1891 investigated the various smoke-consuming devices then in the market. After defining the nature of the problem of smoke-consumption the committee laid down the following ten requirements which any smoke-consuming or preventing device must satisfy in order to fully meet the varying conditions obtaining in ordinary practice, viz. :

1. It should develop such high temperature and oxidizing action as to insure the combustion of the free or separate carbon which forms the visible smoke.

2. It should insure regularity of action under the varying conditions induced by charging fresh coal, cleaning fires, inattention of fireman, etc.

3. It should not be susceptible to derangement under the conditions likely to obtain in use, such as carelessness of firemen, inferior water, bad clinker, etc.

4. If there is any increase in the cost of operation it should be small.

5. The capacity of the apparatus should be such that efficient action will be secured not only when the boiler is working up to its full rated capacity, but even when forced in order to meet extraordinary demands.

6. The apparatus should be readily adjustable to all forms of boilers and boiler-settings.

7. It should be susceptible of application to boiler-settings where the space is already limited.

8. It should be of comparatively low first cost.*

9. Repairs should be small in amount, easily made and low of cost.

10. The apparatus should operate without injury to boiler or other accessories.

The committee classified the various types of smoke-preventing devices which have thus far been proposed, as follows:

1. Steam-jets.
2. Fire-brick arches or checker-work.
3. Hollow walls for preheating air.
4. Coking-arches or chambers.
5. Double-combustion furnaces.
6. Downward-draught furnaces.
7. Automatic stokers.

* This is not evident. With Illinois coals a saving of from 10 to 20 per cent may be made by the use of a good smoke-preventing furnace as compared with the ordinary furnace. This would warrant the use of the most costly furnace or automatic stoker in the market.

Methods of Securing Complete Combustion.—The fundamental condition of perfect combustion of soft coal is that every particle of the gas distilled from the coal, including the water-gas made by decomposing its moisture, be brought in contact with a sufficient supply of very hot air to burn it, the mixing of the gas and air taking place at a sufficient distance from the heating surfaces of the boiler so that they do not become cooled below the temperature of ignition before the combustion takes place. It is impossible to secure this condition in an ordinary furnace with hand-firing and a level bed of coal.

It may be secured, however, to a considerable extent with hand-firing if some modifications of the furnace and of the method of firing are made. The change required in the furnace is the roofing of it with fire-brick and the provision of a large fire-brick combustion-chamber in which there shall be sufficient space and time allowed for the separate currents of gas and of heated air to become intimately mixed before coming in contact with the boiler surfaces.

The Coking System of Firing.—The change required in the method of firing is such a change that the whole bed of the fire shall not at the same time be covered with fresh fire. To effect this, either the coking system or the alternate-firing system may be used. In the first, or coking system, the fresh coal is piled up on the front half of the bed while the rear half has a level bed of half-burned coal upon it. The gases distilled from the fresh coal then pass over the rear half, through which an excess of air is entering, being heated as they pass through the bed of coke. The two currents of gas, one containing the distilled gases and the other the supply of hot air, intermingle in the hot combustion-chamber. When nearly all of the gas has been distilled from the pile of coal in the front half of the furnace, the pile is pushed back and levelled over the rear half, and either immediately or within a minute or two, according to whether the gases have been more or less completely driven off, fresh coal is again piled in front. With some coals the coking system cannot be advantageously used, namely, those coals which contain a large quantity of very fusible ash. In pushing back the coked coal onto the rear of the grates, the ash lying thereon, and which may have been kept below the fusing temperature by the air passing through it, becomes mixed with the coked coal, which just after being pushed back burns with great rapidity, generating a very high temperature, melting the ash and causing it to run and choke the air-spaces in the grate.

The coking system involves a greater amount of labor and attention

on the part of the firemen than ordinary level firing, and they sometimes object to it on that account. To what extent the coking system of firing will reduce the amount of smoke depends on the character of the coal, on the skill of the fireman, and on the size of the fire-brick combustion-chamber. The lower the percentage of moisture and volatile matter the less smoke will be made with any system of firing, and the more complete will be its suppression with the coking system. The smaller the quantity of fresh coal fired at a time, and the greater the care exercised by the fireman to keep the quantities fired each time and the intervals between firing uniform, and to keep the bed of coal in the rear level and not too thick, the less will be the amount of smoke. The larger the combustion-chamber in which the currents of smoky gas and of hot gas surcharged with air unite, the longer time will be afforded for their admixture, the more complete will be the combustion, and the less will be the smoke.

The **Walker Furnace**, Fig. 17, represents a furnace in which the coking system of firing is used. The forward part of the grate, *F*, is stationary, and slopes towards the rear of the furnace. Back of it is a dumping-grate, *D*. The fresh fuel is fired upon the front part of the grate, and after the volatile gases have been distilled it is pushed back upon the dumping-grate. Air is admitted through both grates, and also through the conduit, *K*. The air for this conduit may be

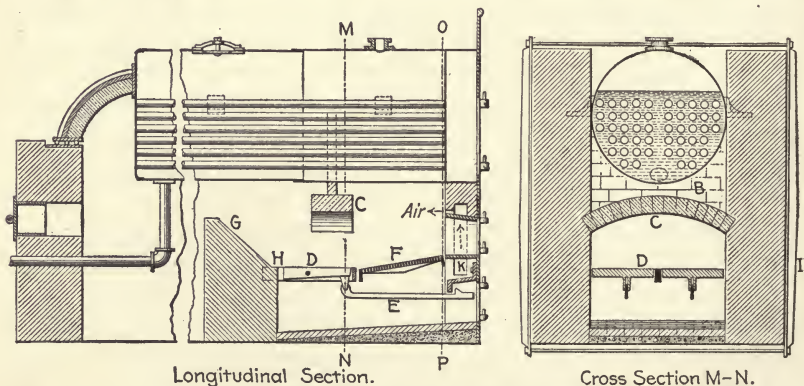

FIG. 17.—THE WALKER FURNACE.

brought from passages in the side walls in which it is heated. A fire-brick arch, *C*, with a vertical wall, *B*, above it, serves to deflect the mixture of air and smoky gases down upon the incandescent coke lying upon the dumping-grate. This insures complete and smokeless combustion if proper care is used in firing.

Alternate Firing.—A method of firing which seems to have all the advantages of the coking system, and none of its disadvantages, is that known as alternate firing. It consists in firing fresh coal, first on one half of the bed of the furnace, and then on the other half, alternately, at equal intervals of time. Instead of covering the whole bed with fresh coal, say every ten minutes, only half the bed is covered at each firing, and the other half is covered five minutes afterwards. After

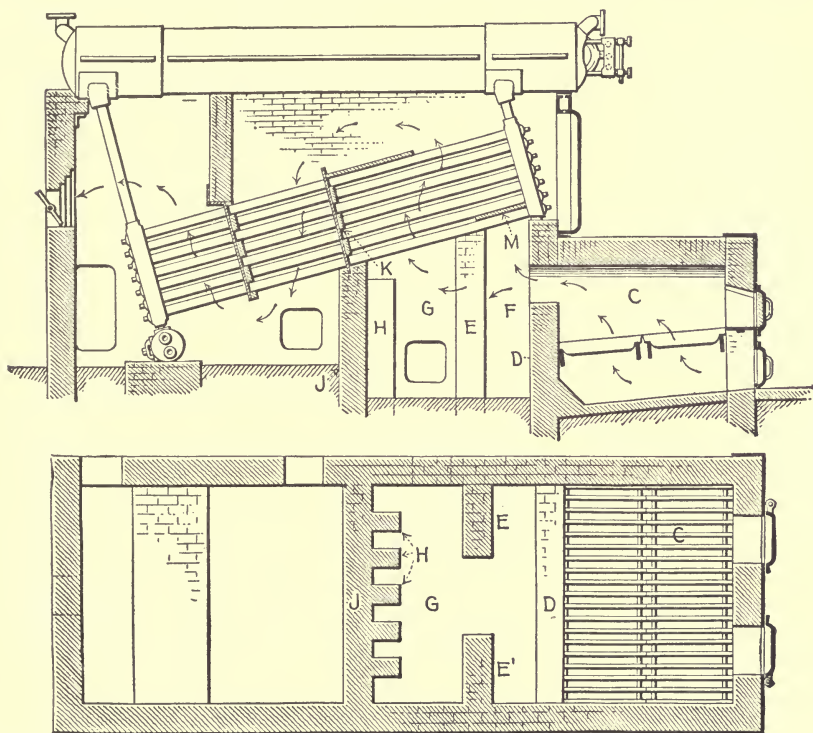

FIG. 18.—THE "WING-WALL" FURNACE APPLIED TO A WATER-TUBE BOILER.

each addition of fresh coal the volatile gases that arise from it come in contact with the current of hot gas, carrying an excess of air, which arises from the half-burned coal on the other half of the bed. In this system of firing the fresh coal may be fired alternately, either in the front and rear of the bed, or on the right and left side, the former being called alternate front and back firing, and the latter alternate side firing. With this system of firing the successful prevention of smoke depends largely on the skill of the fireman, but more especially

on the size of the combustion-chamber, and the opportunity it affords for thorough admixture of the two currents of gas. Baffle-walls placed in the combustion-chambers to compel the gases to take a circuitous direction facilitate the mixture, and together with the side walls and fire-brick roof, have what is called a regenerative action, on the principle of the Siemens regenerators, used in steel-melting furnaces, absorbing heat during the times when the burning gases are the hottest, and giving out heat to the gases when they are cooler, or immediately after the firing of fresh coal.

Alternate firing is of no use unless there is a large combustion-chamber in which the two gaseous currents are mixed and the smoke burned before they are allowed to come in contact with the heating surface.

The "Wing-wall" Furnace.—This furnace was patented by the author May 17, 1898. It is adapted for the smokeless combustion of soft coal, peat, wood, tan-bark, and other fuels that contain large proportions of volatile matter and moisture.

The drawings, Fig. 18, show the furnace applied to a water-tube boiler. *C* is a fire-chamber or oven, built of brick and extending out in front of the boiler. In it the fuel is burned, either on the ordinary grate-bars or by means of a mechanical stoker. *D* is an ordinary bridge wall. *EE'* are two tall vertical walls called wing-walls, built some distance in the rear of the bridge wall. *G* is a combustion-chamber. *HH* are several piers of fire-brick, projecting into the chamber *G*, from the rear wall *J*. *K* is the ordinary partition wall built across the boiler-tubes, and *M* is a tile roof to the chamber *F* to prevent the gases in that chamber from reaching the tubes until after they have passed through the narrow vertical passage between the wing-walls *EE'*.

In operation with hand-firing, the alternate method of firing is used. The fresh coal is spread alternately on the right and left sides of the grate at equal intervals of time. Immediately after firing on one side dense, smoky gases arise on that side, while on the other side an excessive supply of very hot air is passing through the bed of partially burned coal or coke. These two currents, one of cool, smoky gas and the other of clear, hot gas with a large excess of air, pass side by side over the bridge wall *D*, but they are compelled to change their direction and mingle together on passing through the tall, narrow passage between the wing-walls *EE'*, and by so mingling, the gases are burned and smoke is prevented.

The combustion is assisted by the heat radiated from the walls of the combustion-chamber *G* and the piers *H*, which absorb heat during the time when the fire is hottest—that is, just before fresh coal is spread on the grate, and give out heat to the gases in the chamber *G* when the fire is coolest—that is, just after firing, when the smoky gases are escaping. They act on the principle of the Siemens regenerative furnace, commonly used in steel-works.

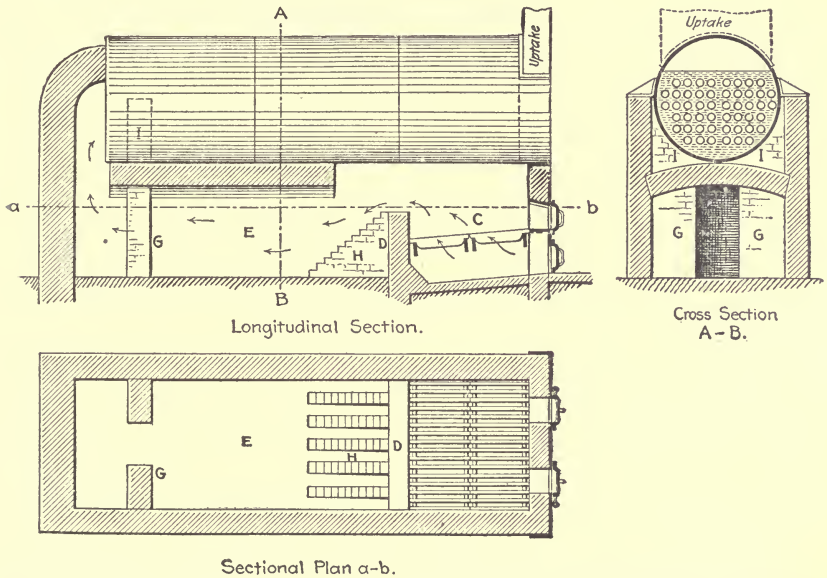

FIG 19.—THE “WING-WALL” FURNACE APPLIED TO A HORIZONTAL TUBULAR BOILER.

Fig. 19 shows a modification of the furnace applied to a horizontal tubular boiler (patented Feb. , 1901). In this arrangement the oven built in front of the boiler is dispensed with, and the space in the rear of the bridge wall is used for a combustion-chamber. *GG* here are the wing-walls, and *II* an intercepting wall, built so as to prevent the gases passing over the arch.

Introduction of Heated Air into the Furnace.—The admission of heated air into the furnace, through hollow bridge and side walls or through channels in fire-brick arches over the furnace, has long been a favorite method of inventors of appliances for producing smokeless combustion, and numerous patents have been taken out for such appliances during the last fifty years or more. The theory of this method of improving combustion is correct, but it has usually failed to come

into extensive use on account of practical difficulties. The usual troubles are that the air is not made hot enough, that not enough air is introduced into the furnace at the time when it is needed, that is, just after fresh coal has been fired, and too much is admitted when little or none is needed, or when sufficient air is passing through the grates. The air-passages also are apt to become clogged with dust. Sometimes air is forced into the passages by means of a steam-jet, and some benefit in diminishing smoke is apparent, but a loss of economy usually results, and the use of the jet is abandoned. Automatic appliances for admitting air just after firing, and shutting it off gradually during two or three minutes following, have also been used sometimes with apparently good results, but they do not appear to have been generally successful. Admitting cold air above the coal will be of no use to burn these gases unless it becomes highly heated after its admission by contact with or radiation from the hot walls of the furnace and combustion-chamber. When there is a long fire-brick combustion-chamber in the rear of the furnace in which the air and gases may unite, the automatic admission of air just after firing, and its gradual shutting off may prove beneficial both in diminishing smoke and in improving economy.

Jets of steam are sometimes blown into the furnace, above the fire, carrying jets of air with them, on the principle of the injector. That they do decrease the amount of smoke in some cases there seems to be no doubt. Reasons which have been given to explain the action of the jet and which may to some extent be true are the following:

(1) The diminution of smoke is apparent and not real. Both the air and the steam dilute the smoke, and make it less dense in appearance as it escapes from the top of the chimney. The steam also escaping from the chimney as a white cloud disguises the smoke and may condense its bulk, rendering it less visible. Further, the chilling action of the air and steam may decrease the rapidity of production of the smoke in the furnace, extending its production over a longer period of time, decreasing its density during that time.

(2) The jet of air violently driven in by the steam and pointed downwards onto the bed of coal, becomes intimately mixed with the gases distilled from the coal, and then if there is a long run through the hot combustion-chamber the mixture will be burned, destroying the smoke.

The steam-jet is in itself a wasteful appliance, for even if the steam is decomposed and the gases afterwards completely burned, forming steam again, it escapes from the boiler superheated to the temperature

of the flue gases, which temperature is always higher than that of the steam in the jet, and there is a consequent loss of heat due to the superheating.

Downward Draft Furnaces.—In ordinary hand-fired furnaces, fresh coal is fed on top of the bed, and the air passes upwards through the grate, then through the very hot partially burned coal or coke lying on the grate, and finally through the fresh coal from which the volatile gases are being distilled. If the direction of the draft can be reversed, the air being admitted above the coal and passing down through it and through the grate, the character of the operation of the furnace is completely changed. The cold air and the cool distilled gases pass together down through the hot coke, and if the air-supply is sufficient the gases will be thoroughly burned and smoke will be prevented. To prevent the burning out of the grate-bars they are made of water-tubes, which are connected by headers with the boiler so as to insure a positive circulation of the water through them.

The Hawley Down-draft Furnace.—This is a form of down-draft furnace which has within the past few years been widely intro-

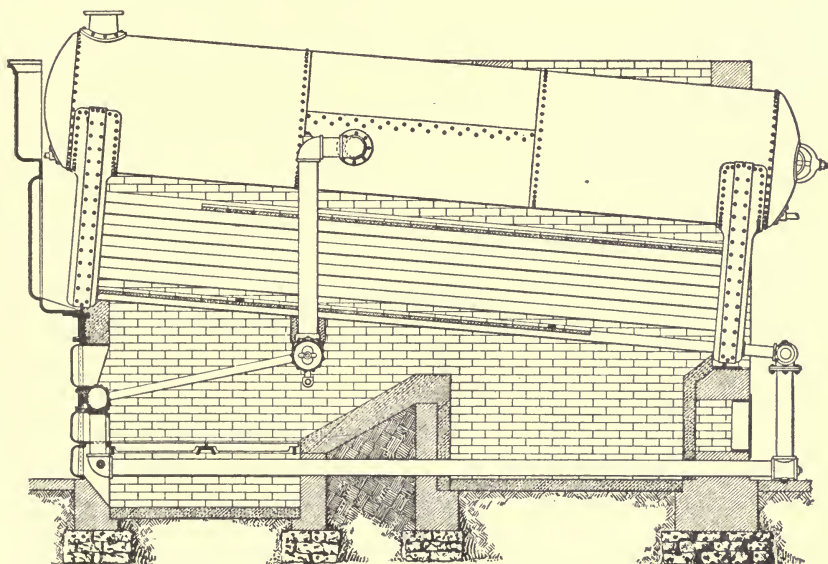

FIG. 20.—HAWLEY DOWN-DRAFT FURNACE APPLIED TO A HEINE BOILER.

duced in the United States, and has given excellent results both in smoke-prevention and in economy of fuel. Besides the water-grate

upon which the coal is fed, there is a lower or common grate, upon which is burned the coke that falls through the water-grate. The greater part of the air-supply is admitted above the fresh coal on the

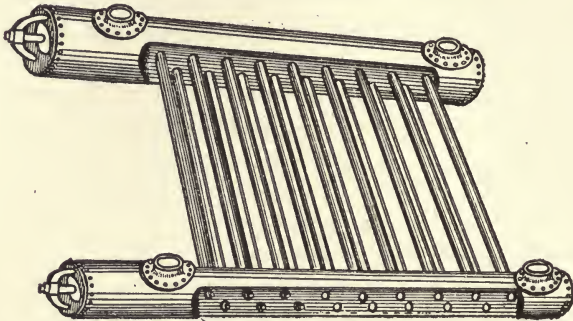

FIG. 21.—WATER-GRATE USED IN THE HAWLEY FURNACE.

water-grate, passing through the coal, and an additional supply is admitted below the lower grate, passing upwards through it to burn the coke and to assist in burning the gases. The space between the two grates forms part of the combustion-chamber in which the gases are burned.

Fig. 20 shows a Hawley furnace as applied to a Heine water-tube boiler and Fig. 21 a view of the water-grate. The pipe-connections by which a circulation of water is insured through the water-grate are also shown in Fig. 20.

Automatic or Mechanical Stokers.—More than fifty years ago mechanical stokers for feeding coal regularly by machinery were successfully used in England, although their use has not even there become by any means universal. Within the last ten years they have become quite common in the United States, especially in large and modern boiler plants. By the use of such stokers the chief objections to hand-firing are avoided, viz., the intermittent supply of coal, the sudden volatilization of great volumes of smoky gas, the alternately deficient and excessive air-supply, and the cooling due to frequent opening of the fire-door. When properly designed and operated these stokers feed both the coal and the air at a regular rate, and when the air and the coal-supply are properly adjusted to each other, and proper provisions, such as a fire-brick combustion-chamber or other means, are made for compelling the currents of gas and air to become completely intermingled, they will burn coal with-

out smoke and at the same time with the maximum economy which the design and proportions of the boiler permit. Moreover, in large plants they are capable of effecting a great saving of labor, especially when they are used in conjunction with modern methods of storing coal in overhead bins and feeding it by gravity through chutes into the hoppers of the stoker. The chief objection to them is their initial first cost. In large well-designed plants, however, this objection is to a great extent, if not entirely, overcome by the fact that when the stokers and their rate of driving are properly proportioned to the boilers, it is possible to obtain from a boiler considerable increase of capacity compared with hand-firing, without any sacrifice of economy, and therefore the number of boilers required may be less than with hand-firing.

The introduction of mechanical stokers in the United States having been so comparatively recent, and the correct methods of proportioning and handling them having been not in all cases well understood, it is not to be expected that there will already be a general consensus of opinion in their favor. As evidence of the difference of opinion concerning them, the following extracts from a report made by Mr. R. S. Hale, of Boston, Mass., to the Steam Users' Association (which association had the short life of one year) in January, 1897, may be of interest:

To the circular requesting information on mechanical stokers we received in all twelve replies.

These covered the Wilkinson, Murphy, Brightman, Hodgkinson, American, Babcock & Wilcox, Roney, and Meissner types, and the twelve plants covered sixteen experiences.

In reply to the question, "Do stokers save coal over hand-firing?" one reply showed a loss in economy, five reported no saving, and six reported a saving. The balance could not tell. One plant reports a large saving due to using a cheaper grade of coal than could be fired by hand.

In reply to the question, "Do stokers save labor over hand-firing?" one found increased cost in labor, three found no saving, and eight found a saving. Three of the four who found a loss or found no saving in labor thought that if they should fully equip their plants with stokers they could arrange to save labor.

In reply to the question, "Do stokers save smoke over hand-firing?" two soft-coal plants thought they did not save smoke, seven thought they did. The others used hard coal or did not reply.

No plant replied to the question as to whether the stoker caused a net saving.

As to repairs, only five had had stokers in use over two years, and

of these three replied that the repairs were "small" or "trifling"; the other two did not reply to the question on repairs.

In reply to the question, "Do stokers respond to a sudden call for steam as well, better, or worse than hand-firing?" five thought they responded slower, one as quickly as, and five quicker than hand-firing.

In reply to the question "as to draft needed," three thought they needed more draft, four thought they needed the same, and one less draft than hand firing.

After trials, in five cases the plants did not intend to increase the number of stokers or had already discarded them. Three plants were doubtful, while six intended to increase the stoker-plant either at once or when they put in new boilers.

The answers to these questions may not appear to be very favorable to mechanical stokers, but there are many possible reasons for the unfavorable replies, other than the inefficiency of the stokers. It is probable that most of the replies were received from parties who are using the stokers with semi-bituminous and not with bituminous coal, and with the former there is not the same margin for saving that there is with the latter. In other cases the stokers may have been handled unskillfully or may not have been properly proportioned to the boiler.

It is probable also that if a more extensive census were taken now of the opinions of users of stokers, the results would be much more favorable, for during the last few years the manufacturers of stokers have done a large business, introducing them in many cases in plants of several thousand horse-power.

Types of Mechanical Stokers.—The stokers now in common use may be divided into four general classes, depending on the kind of mechanism used for feeding the coal. In the first class the coal is carried on grate-bars, either horizontal or inclined more or less, the individual bars, or sometimes alternate bars, being given a reciprocating to and fro, up and down, or rocking motion, by which the coal is gradually advanced along the grates. In the second class the grate is steeply inclined, and the coal is pushed onto its upper end, and slides down slowly as it burns. In the third class the whole grate forms an endless chain of short bars, on which the coal travels horizontally into the furnace, the chain passing over a sprocket-wheel at the end and returning through the ash-pit. In the fourth class the fresh coal is fed in underneath the burning coal, and the gases distilled from it pass through the bed of hot coke above, the action being exactly the reverse of that of the Hawley down-draft furnace, in which the fresh coal is fed on top of the bed, and the gases pass down through the bed of hot

coke beneath. A brief description of some modern forms of stokers will now be given.

The Vicars Mechanical Stoker (Fig. 22).—The fuel is fed from a hopper into two cases or boxes, from which it is gradually pushed by reciprocating plungers onto a coking plate, where it lies in a mass about 12 ins. deep, and where its volatile gases are evolved.

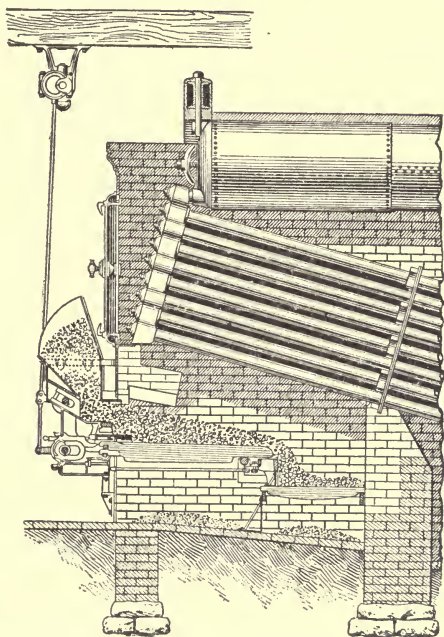

FIG. 22.—THE VICARS MECHANICAL STOKER.

Thence it passes onto the grate-bars, which by a slow reciprocating movement carry the burning mass gradually backward. Such unconsumed coal as reaches the end of the grate-bars, together with the clinker and ash-refuse carried back, are discharged over the ends of the fire-bars onto a stationary grate at a lower level.

The two separate mechanical movements in the operation of this stoker, each independent of the other, are driven by auxiliary power. The coal-feed is varied by altering the rate of motion of the plungers, which by the movement of a lever can be adjusted to a movement from slow to rapid as the consumption of fuel may require. The reciprocating action of the grate-bars is operated in the same way as the coal-feed, but with several intermediate variations from a state of rest to a

movement of $3\frac{1}{2}$ ins. The bars of each furnace are arranged in two sets, each composed of the alternate bars, which sets operate together in moving inward, but return at separate intervals. Thus the fuel is carried inward by the simultaneous action of both sets of bars, and remains in place, without being disturbed by the return of either set. Each successive inward movement of the bars serves to carry the fuel, together with the clinker and ash-refuse, nearer to the inner end of the grate, where the mass at length drops over into the combustion-chamber, and forms and maintains a bank which acts as a bridge and on which the combustion of the unconsumed fuel is in due time completed.

The Coxe Automatic Stoker* (Fig. 23) is of the chain-grate variety. It was designed for burning small sizes of anthracite, but has also been found adapted to bituminous coal. Its peculiar feature is the means

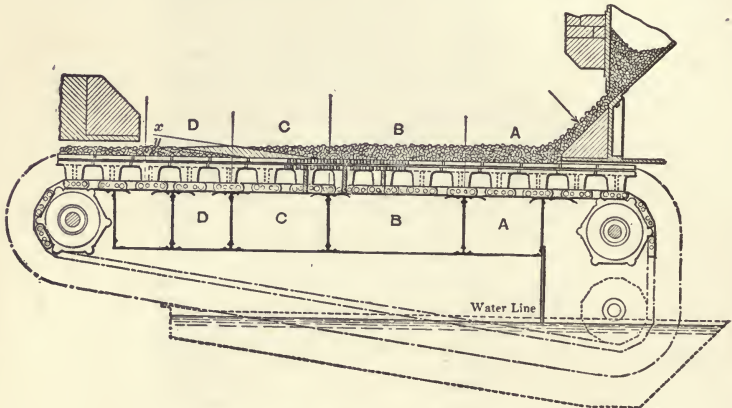

FIG. 23.—THE COXE AUTOMATIC STOKER.

used to graduate the air-supply to the requirements of different portions of the travelling bed of coal. Under the horizontal travelling grate are placed a number of air-chambers or boxes, made of sheet iron, open at the top, and provided with dampers in the partitions between them. Blast from a fan is delivered into the larger chamber *B* in the diagram, and part of it passes into the other chambers at reduced pressures. The air passes from these chambers through the grates at pressures which may be regulated by the dampers. The coal descending from the hopper over the highly heated sloping surface of fire-brick is ignited as it reaches the first section of the travelling grate.

*A detailed description of this stoker is given in a paper by Eckley B. Coxe, in *Trans. Am. Inst. Mining Engineers*, vol. xxii. 1893.

As it passes over the first chamber, *A*, it receives a blast of moderate pressure, then a higher pressure from *B*, then diminished pressures from *C* and *D* as the bed of coal becomes thinner. The object is to subject the coal as soon as it arrives on the grate to a pressure of blast which is the proper one to ignite it, then to burn it with a blast as strong as will produce good combustion, and as the carbon is eliminated and the thickness of the bed becomes smaller to diminish the blast to correspond with these conditions. The mass of coal remains all the time in practically the same position and condition in which it was placed on the grate, except so far as altered by the combustion. The ashes are carried off or dumped by the grate-bars as they descend.

The coal burns out from the bottom; that is, the first thin layer of complete ash forms on the bottom and gradually becomes thicker until it reaches to the top. At first the ash is very hot, but the gentle current of air passing through it gradually cools it off, and when it is dumped into the ash-pit it is not very hot. The shaded portion beginning in *C* and extending into *D* represents the gradual formation of the ash, and the part to the left of that shows the ash practically cooled or cooling.

A certain portion of air from which the oxygen is not removed passes through and cools the ash, but in the first sections of the bed of fuel near *A* a certain amount of carbonic oxide is formed, due to the fact that the amount of air blown through is not sufficient to properly consume all the carbon. This carbonic oxide is burned in the furnace by the air which has passed through the ash.

The results of some tests of the Coxe stoker with pea and buckwheat coal will be found in the chapter on "Results of Boiler Trials."

The Playford Stoker, Fig. 24, is another chain-grate stoker. To the traveling-chains are attached a series of wrought-iron T bars, running across the furnace, and these carry the small cast-iron sections of which the grate is made. Below the chain-grate a screw-conveyor is placed for carrying the ashes forward from the rear of the furnace to the ash-pit in front.

The Babcock & Wilcox Stoker, Fig. 25, is also an endless-chain grate. It has been used with much success in the West with bituminous coals. The cut shows the stoker removed from the furnace. The large vertical pipe is the coal-feeder, which delivers coal from an overhead bin into the hopper. It is driven by a worm-wheel, the power being delivered to the worm from an independent engine through a lever and ratchet-wheel.

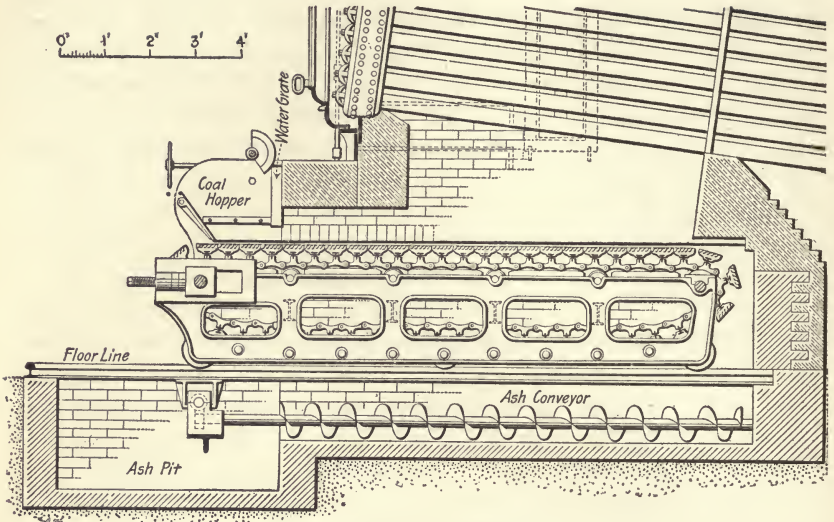

Longitudinal Section.

FIG. 24.—THE PLAYFORD STOKER.

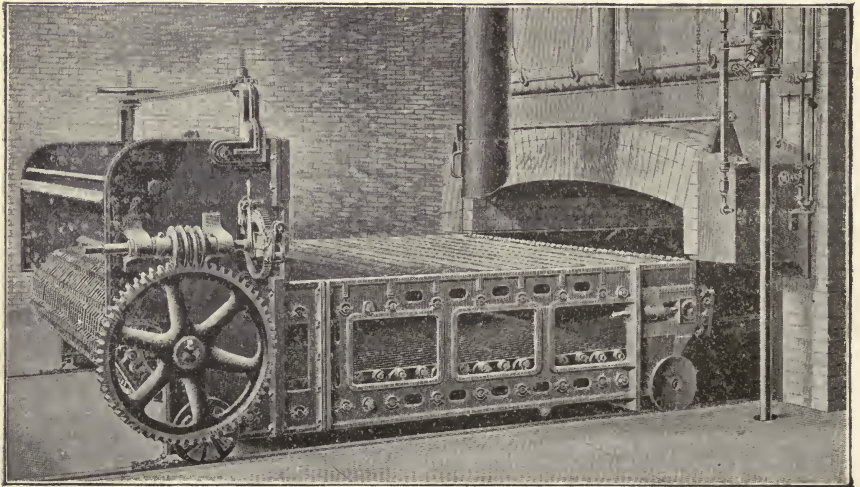

FIG. 25.—THE BABCOCK & WILCOX STOKER.

The Roney Mechanical Stoker—This stoker was first brought out in 1885. The present construction is shown in Fig. 26. It receives

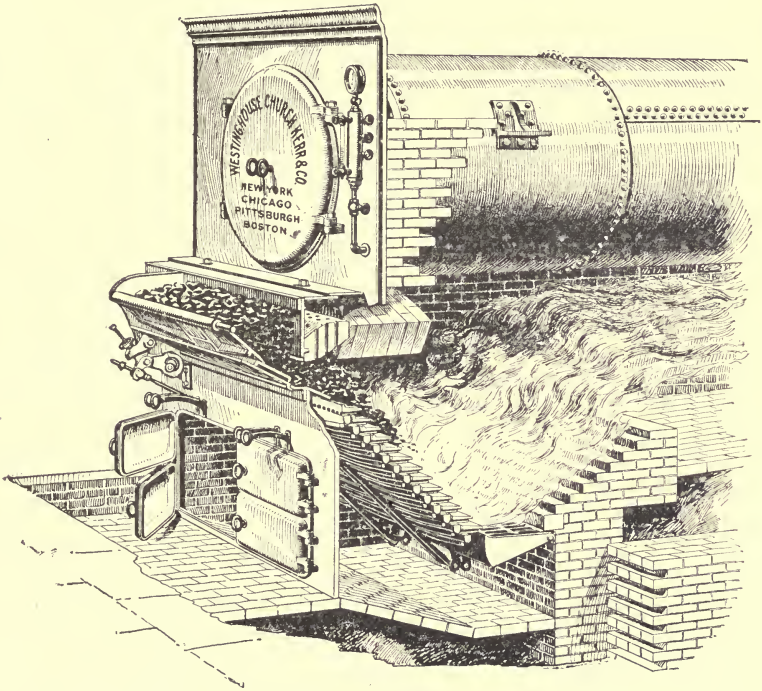

FIG. 26.—THE ROONEY MECHANICAL STOKER.

the fuel in bulk, and, without further handling, feeds it continuously and at any desired rate to the furnace, burns the combustible portion and deposits the ash and cinder in the ash-pit ready for removal.

In the bottom of the coal-hopper is located a sliding pusher, which gradually feeds the coal over the dead-plate and on to the grate. The latter consists of horizontal flat-surfaced overlapping bars, extending from side to side of the furnace, and inclined at an angle of 37 degrees from the horizontal. In the wider furnaces two or more sets of grate-bars are placed side by side, provided with independent actuating connections. The grate-bars rock in unison, assuming alternately a stepped and an inclined position. When they rock forward into the inclined position the burning coal tends to work down in a body, but before it can move too far the bars rock back to the stepped position, checking the downward motion, breaking up the bed of fuel and freely

admitting air through the fire. This alternate starting and checking motion keeps the fire constantly stirred and opened up from beneath, and finally lands the cinder and ash on the dumping-grate, from which it is discharged into the ash-pit. The depending webs of the grate-bars are perforated with longitudinal slots, so placed that the condition of the fire can be seen at all times and free access had to all parts of the grate without the opening of doors. These slots also serve to furnish an abundant supply of air for combustion. The motion of the grate-bars and the feeding device is regulated by two simple adjustments, by which the action of the stoker is controlled and the fires are forced, checked or banked at will.

A coking-arch of fire-brick is sprung across the furnace, covering the upper part of the grate and forming a gas-producer whose action is to coke the fresh fuel and release its gases, which, mingling with heated air, supplied in small streams through the perforated tile above the dead-plate, are burned in the large combustion-chamber above the bed of incandescent coke on the lower part of the grate.

This stoker burns all kinds of coal, from lignite to anthracite, and also waste products, such as tanbark, sawdust, cottonseed hulls, and coke "breeze," without change of grate-bars.

The Acme Stoker is shown in Fig. 27. The angle of the grates can be changed to suit different coals, and lowering to a level with the firing-doors converts the stoker into a hand-fired furnace with shaking-grates. Either bituminous or anthracite coal can be burned as desired.

The stoker consists of a cast-iron front, the mechanism for operating the stoker, a coal-hopper, firing-doors (to be used when the stoker is used as a hand-fired furnace), auxiliary, inclined, and dump-grates, stoker-frame, brick arch, etc. The power to operate is provided by an engine or motor at the side, connected direct to each stoker, or to an overhead shaft which is connected to each stoker, arranged so that each stoker can be operated separately, or all together, as desired. The coal-pusher delivers the coal from the hopper to the dead-plate and grates, and is adjustable from nothing to full capacity, by turning a wheel on the regulator.

The auxiliary coking-grates, just in front of the dead-plate, are movable and sectional, and when put together form square boxes through which a large amount of air is introduced immediately under the fire-brick arch, the reflected heat from which cokes the fuel before it starts down the inclined grates. The inclined grates are set at

an angle of 32° , and are spaced according to the kind of fuel to be used. Each alternate one is movable, the motion being regulated from the front. Their motion is to rise above the fixed bars and then move forward, conveying the burning fuel forward, and then dropping back to their place. By this means the coal-pusher and auxiliary grates can be kept running and the inclined grates kept still, or either or both can be kept in motion at the same time. The dump-grate at

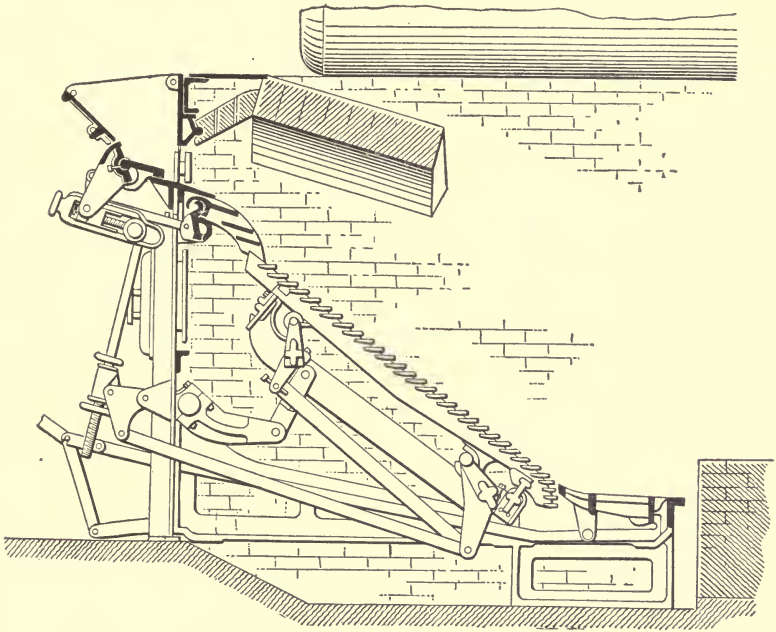

FIG. 27.—THE ACME STOKER.

the bottom and end of the inclined grates is controlled by a lever in front and can be dropped to deposit the refuse in the ash-pit or ash-conveyor.

When it is desired to fire by hand the inclined grates are dropped to a level with the firing-doors, the coal-hopper lid is closed, and the coal is fed by hand through the firing-doors in the usual way. This arrangement of lowering the grates is convenient in starting the fires; a good fire can be started in the ordinary way with the grates lowered, and when the bed of coal is fully ignited, the grates can be raised and the stoker put in operation.

The **Wilkinson Stoker** is shown in Fig. 28. Its peculiar feature is the use of hollow grate-bars through which air is forced by means of small steam-jets. The bars are inclined at an angle of 25° to the

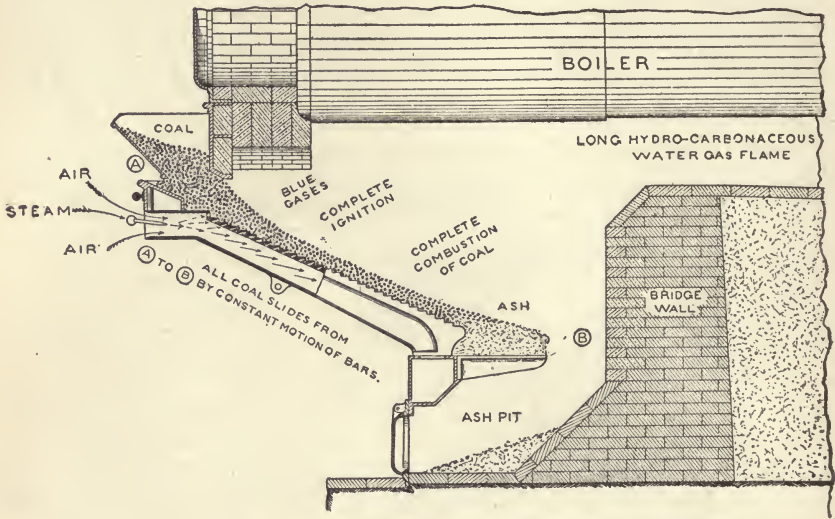

FIG. 28.—THE WILKINSON STOKER.

horizontal. Adjacent bars are moved in opposite directions by a system of toggles controlled by gearing driven by the stoker-engine. An account of some tests of this stoker, with rice coal, made by J. M. Whitham, will be found in *Trans. Am. Soc. M. E.*, vol. xvii. p. 561.

The **Murphy Automatic Furnace** is shown in cross-section as applied to a horizontal tubular boiler in Fig. 29. The furnace is also applicable to all forms both of fire-tube and water-tube boilers. The grates are of a "V" form and in pairs, the upper ends resting on the magazine bed-plate, which is also the feed- or coking-plate, while the lower ends rest in niches on the grate-bearer, which also contains the clinker-bar or clinker-breaker. A fire-brick arch is sprung across the furnace, covering the grate-surface, and on top of each side of the arch there is an air-flue from which hot air is supplied through the series of small openings at the bases of the arch where the brick rests on the ribbed surface of the arch-plates on either side of the furnace. This gives a double side feed- and coking-plate. The coal magazines are provided with stoker-boxes, which are connected by means of pinion-gears to the stoker-shaft, which is automatically moved back and

forth, stoking the coal into the furnace. One grate of each pair of grates is fixed, while the other is movable up and down by a rocker motion at the lower or centre end, thus keeping the fire free from ashes while the coarse refuse and clinker is worked down to the centre, where a rotating clinker-bar grinds it into the ash-pit. The entire operating mechanism is attached to a flat iron bar running across the

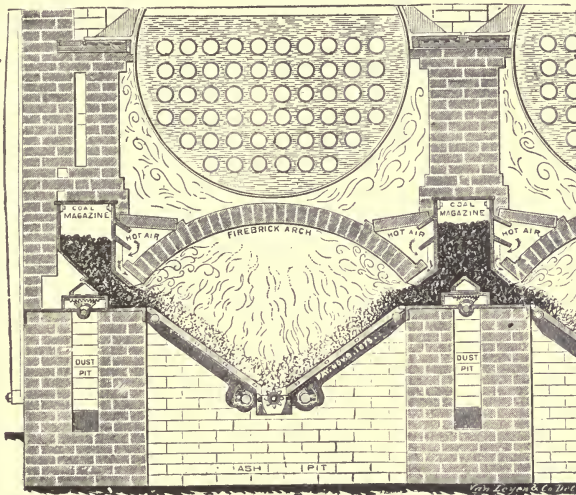

FIG. 29.—THE MURPHY AUTOMATIC FURNACE.

outside of the front, and operated by a little automatic upright engine set at the corner of the setting, which uses about one horse-power per furnace operated. Each revolution of the driving-gear stokes a given but variable quantity of coal into the furnace on each side, moves half of the grate-bars on each side up and down, and turns the clinker-bar partly around. Thus the coal is fed and the fires cleaned constantly. The teeth on the clinker-bar are prevented from becoming hot and worn off by means of a current of air passing through the open centre of the bar and piped to the flue or stack beyond the damper.

The clinker is kept brittle and prevented from sticking by a spray of exhaust steam distributed through a pipe cast into either side of the grate-bearer.

The **American Stoker** is shown in longitudinal section in Fig. 30 and in cross-section in Fig. 31. By this stoker the fresh coal is fed underneath the bed of burning coal, being pushed upward from a deep trough with rounded bottom by means of a tapering screw, which is

driven by an independent steam-motor. The motor is the steam end of a small direct-acting steam-pump. Below the coal-trough there is an air-box, from which air is delivered under pressure through a series

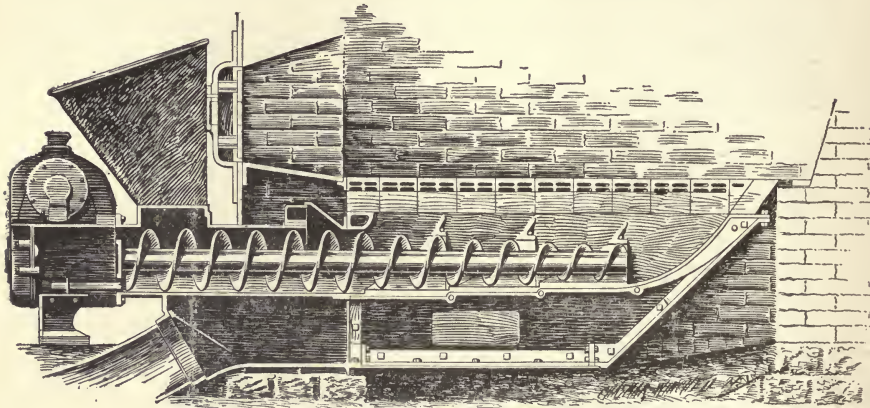

FIG. 30.—THE AMERICAN STOKER.

of heavy cast-iron tuyeres at the level of the top of the trough. The jets of air are delivered horizontally, crossing each other, and cutting through the rounded bed of hot coal lying above. The volatile matter is distilled from the coal in the upper part of the trough and passes

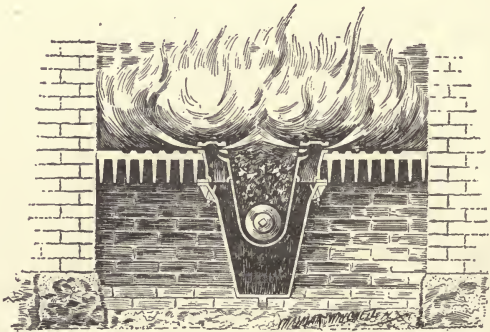

FIG. 31.—THE AMERICAN STOKER.

with the air through the bed of hot coke above, burning without smoke if the air-supply is properly adjusted to the rate of feed of the coal. The space on each side of the stoker, between the tuyere-blocks and the side walls of the furnace, is occupied by dead-plates or grates.

The ash fuses into a clinker and accumulates on the dead-plates in large lumps, which are easily removed. This stoker has had a very successful career with highly volatile coals of the West, and also in the East with semi-bituminous coals. Furnaces over 6 feet in width are equipped with a double stoker. This is a combination of two single stokers feeding from a common hopper and operated by a single motor.

The Jones Under-feed Stoker (Figs. 32 and 33) was patented in

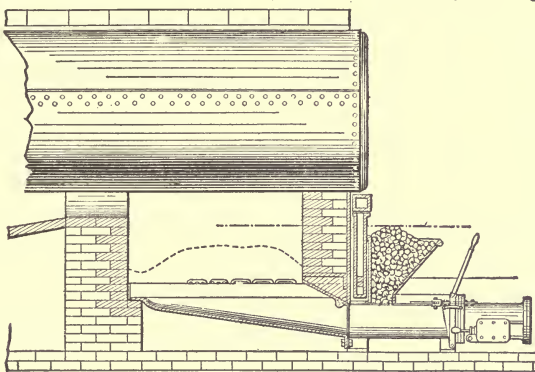

FIG. 32.—THE JONES UNDER-FEED STOKER.

1896 by E. W. Jones of Portland, Oregon. The fresh coal is pushed up through the bed of burning fuel by means of a steam-ram, operated by a hand-lever connected to a valve, by means of which the charges of fuel can be delivered as required. Air at about four ounces pressure is forced through the tuyere-blocks, and up through the heap of burning fuel, and, mingling with the gases from the coking coal, produces an intense and rapid combustion. Owing to the large excess of air delivered at high pressure, and its thorough mingling with the gases, a practically smokeless combustion is obtained. This stoker has been principally used with low-grade Western American bituminous slack coal.

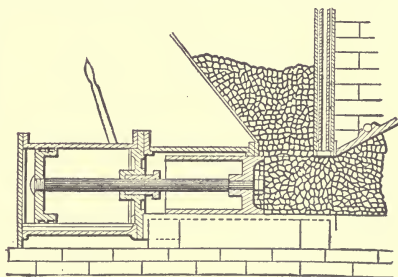

FIG. 33.—CYLINDER OF THE JONES STOKER.

Forced Draft.—The use of forced draft, as a substitute for, or as an aid to, natural chimney draft, is becoming quite common in large boiler-plants. Its advantages are that it enables a boiler to be driven

to its maximum capacity to meet emergencies without reference to the state of the weather or to the character of the coal; that the draft is independent of the temperature of the chimney gases, and that therefore lower flue temperatures may be used than with natural draft; and in many cases that it enables a poorer quality of coal to be used than is required with natural draft.

Forced draft may be obtained: First, by a steam-jet in the chimney, as in locomotives and steam fire-engines; second, by a steam-jet blower under the grate-bars; third, by a fan-blower delivering air under the grate-bars, the ash-pit doors being closed; fourth, by a fan-blower delivering air into a closed fireroom, as in the "closed stokehold" system used in some ocean-going vessels; and fifth, by a fan placed in the flue or chimney drawing the gases of combustion from the boilers, commonly called the induced draft system. Which one of these several systems should be adopted in any special case will usually depend on local conditions. The steam-jet has the advantage of lightness and compactness of apparatus, and is therefore most suitable for locomotives and steam fire-engines, but it also is the most wasteful of steam, and therefore should not be used when a fan-blower system is available, except for occasional or temporary use, or when very cheap fuel, such as anthracite culm at the coal-mines, is used.

The closed stokehold system has as yet been used only in marine practice, where it has some advantage, such as ventilation of the fireroom, over the closed ash-pit system. Induced draft has been used to some extent on land, with good results, but it does not appear to have any especial advantage over the closed ash-pit system, except convenience of application in some situations, as where an exhaust-fan can be placed in the chimney more easily than a fan-blower of sufficient size can be accommodated in the boiler- or engine-room. In a crowded and poorly ventilated fireroom a fan-blower delivering air under the grates and maintaining a pressure of gas in the furnace may sometimes cause objectionable gases and dust to issue into the fireroom, and in such a case induced draft may be preferable.

When an economizer is used to absorb some of the heat escaping from the boilers, it is generally advisable to use forced draft, since the lower temperature of the gases discharged from the economizer reduces the force of draft in the chimney and the friction of the gas passages through the economizer itself reduces the force of draft at the boiler.

Forced draft is especially valuable in large boiler-plants, such as those of electric light and power stations, where the demand for steam

is much greater during a few hours in the day than during the rest of the time. A boiler-plant which would be insufficient with natural draft to supply the steam required during the hours of heaviest load, may be able to supply it with ease by the aid of forced draft.

When forced draft is used, it is advisable to provide it with automatic regulation, the delivery of steam to the engine driving the fan being regulated by a reducing-valve, or a cut-off valve, controlled by the pressure in the boiler, as in the Beckman system. This system consists of a fan-blower, driven by a small engine, delivering air into a conduit built under the bridge wall, which conduit may be common to a battery of boilers, and thence through openings into the ash-pit under the grate of each boiler. In the steam-pipe leading to the engine there are three valves. The first automatically opens or closes as the steam-pressure falls or rises. The second is a reducing-valve which delivers to the engine steam of the pressure required to drive the engine at the right speed for furnishing the air to burn the particular kind of fuel used. The third is a by-pass valve which lets enough steam into the engine while the first valve is closed to keep the engine just moving and furnishing enough air to keep the grates cool. The damper leading from the air-conduit into the ash-pit is closed when the boiler is out of use or during cleaning.

The Howden Hot-air System.—In 1884 Mr. J. Howden applied to the boilers of the *City of New York* a forced draft apparatus in which the air-supply was heated by being circulated around a series of tubes, through which the hot flue-gases passed on their way to the stack. In this system part of the hot air is delivered into the ash-pit, and part above the bed of coal in the furnace. The system has been extensively adopted in marine practice. Among the advantages claimed for it are: 1. Part of the heat which would otherwise escape in the flue-gases is returned to the boiler. 2. By whatever amount the air for combustion is increased in temperature by the waste gases, the average temperature of the furnaces is practically raised to the same extent. If, say, 200° is added to the air of combustion by the air-heaters, the average temperature of the furnaces is raised 200° , and the evaporative power of the heating surface is thereby increased. 3. The gases from the burning fuel combine more readily with the oxygen of the air of combustion as the temperature of the fire increases.

Retarders.—In connection with the Howden system, spiral strips of metal, shown in Fig. 34, are placed in the tubes of the boiler. These compel the gases to take a spiral motion in passing through the

tubes, causing them to come more directly in contact with the surface of the tubes, and by conducting heat through the metal of the retarder into the metal of the tubes increasing their efficiency.



FIG. 34.—A RETARDER.

Results of tests of a horizontal fire-tube boiler with and without retarders are given in a paper by J. M. Whitham in *Trans. A. S. M. E.*, vol. xvii. p. 450. Among his conclusions are the following:

1. Retarders show an economic advantage when the boiler is pushed, varying in the tests from 3 to 18 per cent.

2. Retarders should not be used when boilers are run very gently and when the stack-draft is small.

The **Ellis & Eaves Hot-air System** is similar to Howden's, but the draft is produced by a fan placed at the base of the funnel. The air is heated by being passed through the tubes in the heater, while the hot gas circulates around them. Both the Howden and the Ellis & Eaves systems are illustrated and discussed at length in Bertin & Robertson on "Marine Boilers."

An extensive series of experiments on the use of warm blast was made by J. C. Hoadley in 1881, and described at great length in *Trans. Am. Soc. M. E.*, vol. vi. p. 676. The results, according to Mr. Hoadley, showed a possible net saving of from 10 to 18 per cent over the best attainable practice with natural chimney draft and air at ordinary atmospheric temperatures. Notwithstanding these results, the warm-blast system has not as yet made any headway in land practice.

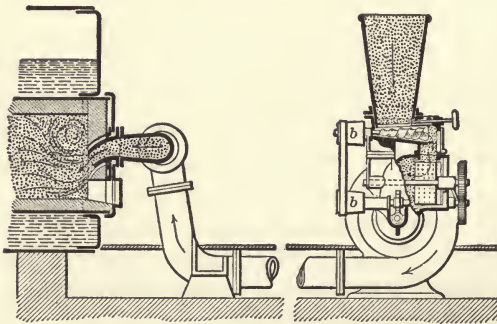

FIG. 35.—METHOD OF BURNING COAL-DUST.

Furnaces for Burning Coal-dust.—Fig. 35 shows a coal-dust stoker patented in 1895 by F. De Camp of Berlin, Germany. The

coal is ground in a mill and carried to the hopper of the stoker by a travelling conveyor, from which it is delivered into the furnace by a fan-blast. The quantity of coal-dust as well as the quantity of air blown into the furnace is regulated by slides. The advantages claimed for the apparatus are that it is an automatic stoker and forced-draft system combined, and that the combustion is complete and smokeless.

The objections are, the cost of power for grinding the coal into a fine powder and for driving the fan, together with the extra labor required to keep the flues clean, on account of the large accumulation of ash and partially burned coal-dust which is carried over by the blast.

The Wegener Apparatus for Burning Powdered Coal.—Fig. 36 shows an apparatus for burning powdered coal, invented by Carl Wegener, and first used in Germany in 1892. It is described as follows:

Coal ground so that it will pass through a sieve of 125 meshes per linear inch is fed into the hopper, whence it falls on to a fine sieve about $5\frac{1}{2}$ in. diameter. The sieve is tapped from 150 to 250 times a minute, in order to cause the coal to fall through it regularly, by means of a knocker on a vertical shaft driven by a wheel placed in the path of the entering air-supply. The air ascending in the inlet-pipe, as shown in the cut, meets the descending shower of powdered coal, mixes with it, and carries it into the furnace. If the air-supply is sufficient, smokeless combustion will result.

Records of tests of the Wegener apparatus* indicate that it does not give any higher economy than can be obtained by mechanical stokers, or other means of burning soft coal, which do not require the coal to be powdered.

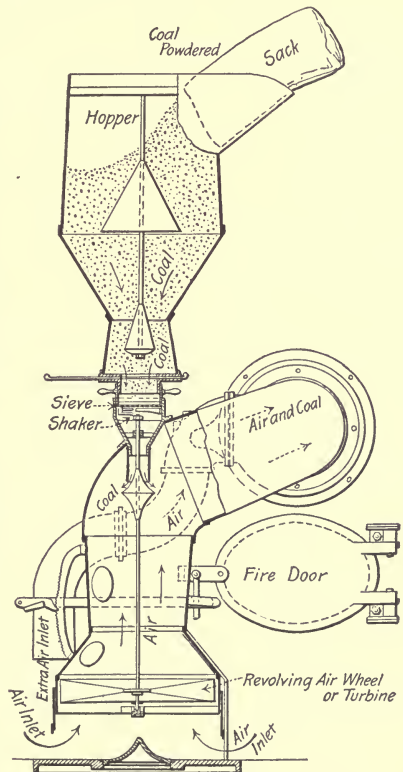

FIG. 36 —WEGENER'S POWDERED COAL APPARATUS.

* *Engineering News*, Sept. 16, 1897.

Methods of Burning Petroleum.*—The simplest and best way of burning liquid fuel is by injecting it in the form of spray by means of a jet of steam into the furnace and allowing the right amount of air to mix with it. The number of different injectors or burners that have been devised for this purpose is legion.

The simplest device would consist of two tubes fastened together, as shown in the annexed sketch, Fig. 37. In this, 1 is the oil feed-pipe; 2, a cock for regulating supply of oil; 3, the steam-pipe; 4, the valve for regulating supply of steam; 5, a guard around pipe preventing overflow.

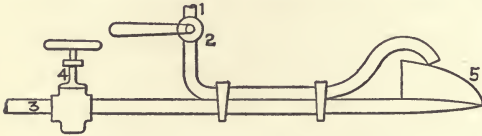

FIG. 37.—PETROLEUM BURNER.

The lower tube is flattened out to a thin, broad opening, from which the stream of air or steam issues under pressure. The upper tube allows a stream of oil to flow from the supply-tank, this flow being regulated by the supply-cock. The oil is conducted by the guard, 5, which prevents it flowing over the sides of the lower steam-pipe, and distributes it in a thin sheet over the rapidly issuing steam, with the result that the oil is rapidly carried forward in the form of a finely divided spray, which is the next thing to gas, and ignites almost as easily. By changing the shape of the issuing jet of steam, different shapes may be given to the flame. If we give the steam-jet a fan-shaped opening, the greater part of the oil will be delivered at the sides and we will have a wide and short flame. If, on the contrary, we desire a long, narrow flame, we give the steam-jet a concave opening, then most of the oil is delivered on the centre of the steam-jet and is propelled forward to a considerable distance.

Those who try to improve the efficiency of a fuel by altering the burner resemble a man who seeks to improve the steaming of his boiler by changing the injector. The place to work at and improve is inside the fire-box or combustion-chamber. The oil fuel must be so broken up or pulverized as to allow of its mixing with the air and being instantly consumed. If it is not consumed in the fire-box, it issues either in the form of smoke or of foul-smelling, unburned gases, and fuel is wasted.

If we take a vessel filled with benzine and set fire to it, it burns with a heavy flame, and large quantities of black smoke are given off. As no air can get to the interior portion, combustion takes place on the outside, and as the contained hydrogen has a greater affinity for oxygen than carbon, it combines with most of the oxygen furnished by the air, the carbon is set free and is visible in the form of a heavy, black smoke.

If we admit air to the interior of the volatile gases which are being given off, more oxygen is supplied and part of the carbon burns and the smoke diminishes, and if arrangements are made so as to ad-

* Extracts from a paper by H. Tweddle, in *The Engineering and Mining Journal*, Oct. 21, 1899.

mit sufficient air to all parts of the benzine and its vapor, then we will have complete combustion and no smoke will be given off.

In order to obtain the greatest efficiency from fuel oil, it should be burned in a fire-brick combustion-chamber, so as to obtain the very highest possible temperature. Notwithstanding the fact that a certain amount of heating surface is covered by the brickwork, experiments have shown that there is both an increase in evaporation and a saving in fuel with the lined fire-box.

Use of Petroleum in Locomotives.—Mr. Tweddle describes the use of petroleum as fuel for locomotives on the Oroya Railroad, in Peru, where he introduced it in 1890. Two locomotives, exactly alike in all other respects, were tested, one with coal and the other with oil. They were American Rogers engines, Mogul type, with 47 in. drivers; cylinders 18×24 in.; weight of engine 38 tons, tender 28 tons; five cars averaging 18 tons each. The grades were as high as 4.2 per cent, or 1 in 27, with some sharp curves. The average consumption of coal for a month was 79.30 lbs. per train mile, and that of oil 38.55 lbs., or less than half.

The arrangement for the interior of the fire-box is shown in Fig. 38. No alterations were made in the fire-box, while but few additions

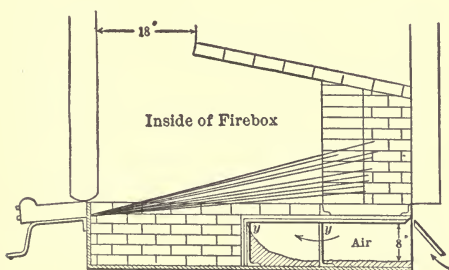

FIG. 38.—PETROLEUM FURNACE.

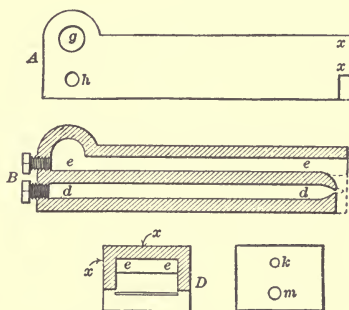

FIG. 39.—OIL-BURNER.

were made to the regular ash-pan. The back damper was completely closed, a large front damper with about 2 sq. ft. superficial opening being arranged in front. A plate with an air-opening 20×14 in. supported the fire-brick at the back of the fire-box, which receives the vaporized oil.

In Fig. 39, the burner is represented. *A* is a general side view of burner; at *g* it is tapped for a $1\frac{1}{4}$ -in. oil-pipe, and at *h* for a $\frac{1}{2}$ -in. steam-pipe. In the sectional view, *e e* is the oil-passage, *d d* is the steam-passage; both these passages being 3 by $\frac{3}{4}$ in. *D* represents the front end of the burner, and *E* represents the back end of the burner.

The oil coming through the passage, *e e*, falls directly on the steam

shooting through the narrow slit at the end of the passage, $d d$, and is completely atomized.

With this burner the bricks do not serve in any way for breaking up the oil, but merely as a white-hot retort in which air and vaporized oil are mixed in the proper proportions.

The supply of air is regulated by the front damper, the supply of oil by a wheel-valve worked by the fireman's hand in the cab. The steam is seldom touched except when an engine is lying up for any length of time at a station. With the oil and air under such easy control there is no difficulty in obtaining perfect combustion without smoke.

The holes at the back of the burner are closed with plugs. By unscrewing these the burner can be quickly cleaned without removing; this, however, is rarely necessary, the burner, as a rule, keeping perfectly clean for an indefinite period.

The burner is cast in one piece and finished by hand. The length of the burner is entirely arbitrary. The width is made to suit the quantity of fuel to be introduced.

On the heavy grades of the Oroya line, as much as 220 lbs. of coal are burned per mile, or 110 lbs. of oil. To perfectly spray such a large flow of oil, a certain width of passage is necessary. The burner best adapted to such heavy work had an oil-passage 3 in. wide and a steam-outlet of $3\frac{1}{2}$ in. The oil-aperture was 3 by $\frac{3}{4}$ in., the steam-aperture $3\frac{1}{2}$ by $\frac{1}{4}$ in.

Around the oil-opening runs a sort of projecting hood which prevents any oil from leaking when rounding sharp curves. Steam from another locomotive is used in getting up steam; 100 lbs. pressure from cold water has been shown on the steam-gauge in 25 minutes, but an hour is generally taken, so as not to strain the boiler. If necessary wood can be used to raise steam.

The oil-fired engine, after running six months, showed no signs of leaking or straining. About 150 fire-brick were used for the whole brickwork, including the arch. This brickwork lasts from six to eight months.

The Urquhart Oil-burner, used in locomotives in Russia, is shown in Fig. 40. The oil runs down a pipe, which ends in the external nozzle of the injector, while the steam passes through the inner nozzle, which it enters through a ring of holes, the steam- and oil-cavities being separated by a stuffing-box packed with asbestos. This packing is renewed once a month. The steam-supply is regulated by a valve, and the oil-supply by screwing the steam-nozzle backward and forward in the external nozzle, thus varying the section of the annular passage. This is effected by a worm and worm-wheel, the latter of which is connected to the steam-nozzle by a feather-key, while the former is on a shaft which terminates in a position conveniently accessible to the fireman. The injector is entirely outside of the fire-box,

so that the carbonizing of the oil at the nozzle is reduced to a minimum. The blast of oil and steam is delivered into the furnace through a tube into which the nose of the injector projects, and through which a supply of air is also drawn by the action of the jet.

The amount of steam required to operate the injector on the Russian railway, according to Mr. Urquhart, is from 8 to 13 per cent of the steam made by the boiler, the highest percentage being required in winter.

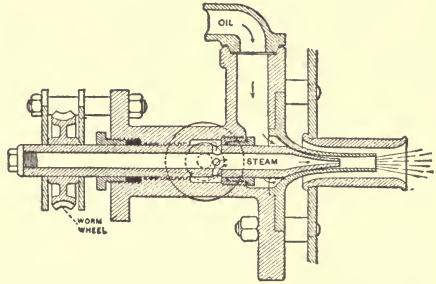

FIG. 40.—THE URQUHART OIL-BURNER.

Furnaces for Burning Green Bagasse and other substances containing a great deal of water, such as wet tan-bark,* require very large

fire-brick combustion-chambers, in order to give plenty of room and time for the combustion of the distilled gases before they are allowed to reach the heating surfaces of the boiler. The fuel should be fed either in small quantities at a time or else in a steady stream, so that the evaporation of its moisture may proceed at a uniform rate and chill the furnace as little as possible. Fig. 40a shows an end view of Cook's bagasse burner, placed

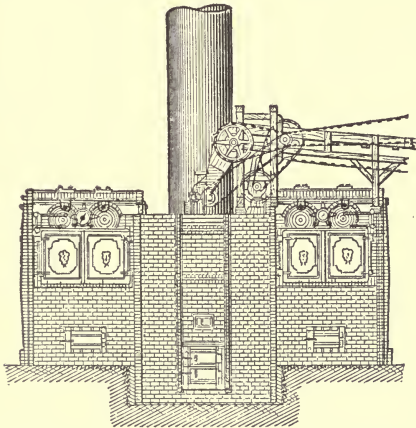

FIG. 40a.—BAGASSE FURNACE, END VIEW.

between two water-tube boilers. It will be observed that the structure is larger than the boiler-setting in end view, and its length is also much greater than that of the boiler-setting. It consists of a large fire-brick oven with a smaller chamber beneath. In the rear of the oven, between it and the chimney, a tubular heater is placed, in which the air-supply is heated by the gases on the way from the boiler to the chimney. The fuel is delivered to the furnace automatically, by means of a conveyor.

* For experiments on tan-bark furnaces see page 136.

CHAPTER VIII.

SOME ELEMENTARY PRINCIPLES OF STEAM-BOILER ECONOMY AND CAPACITY—THE PLAIN CYLINDER BOILER.

IN this chapter we will discuss by a somewhat elementary method, without the use of any algebraic formula, the principles upon which depend the economy and the capacity of the heating surface of a steam-boiler, using for illustration the plain cylinder boiler. In the succeeding chapter the same subject will be treated in another manner, with the use of some mathematics. The conditions which determine to a great extent how large a boiler, or battery of boilers, should be used for a given purpose are: The quantity of steam required; the quality and the cost of fuel; the degree of fuel economy desired; the quality of the water supplied; the regularity of the demand for steam; the size and shape of the space available, etc.

Let us consider how the size and form of a boiler are governed by the conditions of quantity of steam required and by the degree of fuel economy desired.

Instead of taking the problem that is usually presented, viz.: "A certain quantity of steam is required, what shall be the form and size of the boiler to furnish it?" it will better serve the purpose of elementary instruction to state the problem in the reverse manner, viz.: "Given the form and size of a certain boiler, how much steam will it furnish?"

Capacity of a Plain Cylinder Boiler.—We will begin the study of this problem by taking an example of the simplest form of boiler, a plain cylinder of a size that is still commonly used at anthracite coal-mines, viz: 30 in. diameter and 30 ft. long. It is provided with a setting of brick-work, the side walls being 3 feet apart, and with an ordinary grate, 3 ft. wide and 4 ft. long, or 12 sq. ft. of grate-surface. At the rear end there is a flue leading to a tall chimney. The side walls of the setting are built in at the top so as to touch the boiler at the middle of its height, so that only one-half of the boiler is exposed

to radiation from the fire and to contact with the heated gases. The water-level is carried a few inches above the middle of the boiler, so

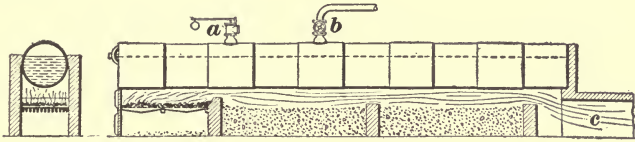

FIG. 41.—PLAIN CYLINDER BOILER.

that at no time is any part of the external surface of the boiler exposed to the flame or heated gases without having water on the opposite inner surface. The boiler is made of steel, $\frac{1}{4}$ inch thick, which is ample for strength, and is supposed to be kept free from scale on the inside and from deposits of soot and ashes on the outside. The upper half of the boiler, above the brick walls, is covered with a non-conducting covering, to prevent excessive loss of heat by radiation. Such a boiler is shown in Fig. 41.

The boiler being 30 ft. long and $2\frac{1}{2}$ ft. external diameter, and the lower half of its surface being heating surface, the area of the heating surface is $\frac{1}{2}$ of $30 \times 2\frac{1}{2} \times 3.1416 = 117.81$ sq. ft. We can make this 120 sq. ft. by letting the side walls touch the heating surface $\frac{1}{2}$ in. above the middle of the boiler; or, if we let them extend $7\frac{1}{2}$ in. above the middle, raising the water-level to correspond, until it is within 5 or 6 in. of the top of the boiler, we can make the heating surface equal to two-thirds of the whole external cylindrical surface of the boiler, or 157 sq. ft. This will, however, not be generally advisable, since by bringing the water-level so close to the top of the boiler there would be danger of carrying water into the steam-pipe, making what is known as "wet steam." For the purpose of this calculation, therefore, we will consider the heating surface as 120 sq. ft. The grate-surface being, as already stated, 12 sq. ft., the ratio of heating to grate-surface, which ratio is a term commonly used in describing steam-boiler proportions, is 10 to 1.

This simple form of boiler, when properly built and erected, supplied with good water, and well taken care of, has many excellent qualities, which have caused it to remain a favorite form of boiler in some parts of the world, and especially in the anthracite coal regions of Pennsylvania, ever since high-pressure steam began to be used in steam-engines, a century ago. Its disadvantages, which have caused it to be

generally displaced by other forms, will be treated of later. The study of the chief conditions which govern boiler-capacity and boiler-economy can be more easily begun by reference to this form of boiler than to any other, and it is for this reason that it has been selected for discussion in this place. The theoretical principles which may be developed in treating of this boiler will apply in great measure to all other forms of boilers.

Having thus described the boiler, we are now ready to take up the question, "How much steam will it furnish?" A direct answer to the question is: "That depends on circumstances, and especially upon the amount and upon the quality of coal that is burned under it. One boiler of the form and dimensions here given may furnish three or four times as much steam as another boiler exactly like it." This answer is correct, but it is not sufficiently definite for our purpose. If the capacity of the boiler depends upon circumstances, we wish to know, with some approach to accuracy, what the boiler will do under different sets of stated conditions, and how the conditions affect the capacity of the boiler and at the same time the economy of fuel.

We will begin this study by assuming that under all the different conditions now to be considered the steam-pressure is maintained at 100 lbs., not by means of a damper regulator, which is occasionally used, but by the discharge of the steam into a steam-main fed also by other boilers in which main the steam-pressure is maintained constant under a possible varying demand by means of varying the rate of driving of the other boilers than the one being considered. The uniformity of pressure might also be obtained by having the steam escape through a loaded valve, similar to a safety-valve, which is set so as to open whenever the pressure is 100 lbs., and to shut below that pressure. We will also assume that the feed-water is supplied at a temperature of 155° Fahrenheit. These two assumptions are made merely for the purpose of simplifying the problem, and thereby shortening to some extent the arithmetical computations involved. To evaporate a pound of water supplied at 155° F. into steam at 100 lbs., gauge-pressure, requires just 10 per cent more heat than to evaporate a pound of water supplied at 212° F., into steam at ordinary atmospheric pressure at the sea-level, or "from and at 212°," a term frequently used in discussions of boiler-economy. Results of boiler-tests are commonly reduced from the figures obtained under the "actual conditions" of the test to the equivalent evaporation "from and at 212°" by multiplying these figures by a "factor of evaporation,"

which factor may be found by calculation from the formula $F = (H - h) \div 965.7$, in which H and h are respectively the heat-units in 1 lb. of steam of the given pressure and in 1 lb. of water of the given temperature found in the tables of the properties of steam and water, or it may be taken directly from a table of such factors. In the present case the "actual conditions" assumed are: Feed-water 155° ; steam-pressure 100 lbs. by guage (corresponding to a temperature of 337° F.), and factor of evaporation 1.10.

Calculations of Fuel Economy.—We now assume, as the first condition which governs the rate of driving of the boiler, that the coal used is of a fairly good quality, equal in heating value to an ideal perfectly dry coal containing 85 per cent of pure carbon and 15 per cent ash.

Let us also assume that we have the draft of the boiler, and the thickness of the bed of coal on the grate, so regulated that enough air is supplied to burn the carbon of the fuel thoroughly, forming carbonic acid gas, or CO_2 . Each pound of coal burned will require about 20 lbs. of air to burn it, including enough excess of air to insure that no portion of the carbon is burned imperfectly, or to carbonic oxide gas (CO). The 20 lbs. of air supplied per pound of coal will measure about 260 cubic feet, if measured at a temperature of 60° F.

The complete combustion of a pound of coal will generate a definite quantity of heat, which may be calculated and expressed in "heat-units," or "British thermal units."

The quantity of heat which may be produced by the complete combustion of 1 lb. of carbon is, approximately, 14,600 B.T.U.

The quantity of heat required to evaporate 1 lb. of water from a temperature of 212° into steam at the same temperature, or from and at 212° , is 965.7 B.T.U.

The quantity of heat required to evaporate 1 lb. of water supplied at 155° into steam at 100 lbs. gauge-pressure, is 10 per cent greater than this, or 1062 B.T.U.

Dividing 14,600 by 965.7 we obtain 15.21 lbs., which is the quantity of water which may be evaporated from and at 212° by the complete combustion of 1 lb. of carbon, on the supposition that all the heat generated is used to evaporate the water and none is allowed to escape by radiation or in the gases produced by the combustion, conditions which are ideal, and impossible to realize in practice.

A coal whose heating value per pound is equal to 85 per cent of that of pure carbon, is theoretically capable of producing 85 per cent

of this result, or $.85 \times 15.21 = 12.93$ lbs. evaporation, from and at 212° , per pound of coal.

If the steam is generated at 100 lbs. pressure from feed-water at 155° , the theoretically possible evaporation is $\frac{100}{110}$ of this, or $12.93 \div 1.1 = 11.75$ lbs. of steam per pound of coal, 1.1 being the "factor of evaporation."

This is the maximum amount of steam which it is possible, theoretically, to produce from 1 lb. of coal of the quality assumed, and under the conditions given, viz., feed-water at 155° and steam-pressure 100 lbs., in an ideal boiler, in which there is no waste of heat by radiation, by escape in the chimney gases, and no waste of coal by imperfect combustion, by falling through the grate-bars or by removal in the ashes. In practice all these wastes occur, and the percentage of the ideal result which may be obtained in a test ranges from 80, under unusually favorable conditions, down to 50 or even less, when the conditions are unfavorable. If we take 75 per cent as the highest figure which is likely to be reached in every-day practice, with good coal and with a boiler which is well designed and driven at a moderate rate, then we may expect that the coal of the quality given, with feed-water at 155° and steam at 100 lbs., will evaporate $11.75 \times .75 = 8.81$ lbs. as a maximum; and if the boiler is not properly designed for the service, or is driven at too high a rate, the evaporation per pound of coal may be much less than this figure.

Reversing the order of the calculations we have:

| | |
|--|-----------|
| Actual evaporation per lb. of coal..... | 8.81 lbs. |
| Equivalent evaporation from and at 212° , 8.82×1.1 | 9.69 " |
| Equivalent evaporation per lb. combustible, $9.69 \div 85$ | 11.40 " |
| Efficiency, $11.40 \div 15.21$ | 75% |

Boiler Capacity Depends Upon Economy.—The discussion thus far has apparently made a wide digression from the problem with which it started, viz.: how much steam will be furnished by the boiler of the form and size selected. The complete answer to the problem, however, is so complicated with the answer to the other question of how much steam may be generated from a pound of coal, that it seemed advisable to first give some consideration to the latter question. It will be seen that the amount of steam that may be made by a boiler of a given size depends upon the amount of coal which may be burned under it, but is not directly proportional to the amount of coal; and the amount of steam that may be generated by the combustion of a pound of coal

depends upon the boiler and upon the rate at which the boiler is driven.

Returning now to our cylindrical boiler 30 ft. long, let us suppose that its length is divided into 10 parts or sections, of which the first two sections are directly exposed to radiation from the fire, and the other eight receive heat by conduction from the heated gases in their passage to the chimney. It is evident that the first and second sections will each transmit a greater quantity of heat into the water than the third, that the third will transmit more than the fourth, and so on. The gases will gradually diminish in temperature as they travel from the furnace to the chimney. The amount of heat transmitted to the water by each square foot of heating surface in a given time will depend upon the difference between the temperature of the heated gases on one side of the plate and that of the water on the other side; the greater this difference of temperature the greater the heat transmitted. Experiments show that it varies about as the square of that difference. Thus the heat transmitted will be four times as much when the difference is 1000° as when it is 500°.

Considering then that our boiler is divided into sections, as in Fig.

42, and that a fire is burning on the grate, consuming a certain quantity of coal per hour, and generating a temperature which

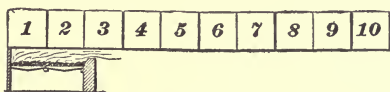

FIG. 42.

in the first two sections averages 2600° F., the reduction in temperature may be considered to take place as follows, the temperature being taken at the end of each section :

| | | | | | | | | | |
|--------------------|------|------|------|------|-----|-----|-----|-----|-----|
| Section No..... | 2 | 3 | 4 | 5 | 6 | 7 | 8 | 9 | 10 |
| Temperature F..... | 2200 | 1630 | 1290 | 1100 | 970 | 880 | 820 | 770 | 730 |
| Reduction..... | | 570 | 320 | 190 | 130 | 90 | 60 | 50 | 40 |

The reduction of the temperature of the consecutive sections is a measure of the quantity of heat transmitted by each section, for the quantity of heated gas remains the same, and the quantity of heat in a given quantity of gas is proportional to its temperature.

Suppose now we increase the quantity of coal burned on the grate, so that a greater quantity of heated gas is formed. The thickness of the bed of coal being increased with the increase of draft, so that the same amount of air is used per pound of coal, the same temperature in the furnace, viz., 2600°, may be obtained; but the temperatures of the sections beyond the furnace will be higher than before, because the

quantity of heated gas and its velocity of passage toward the chimney are both increased, and the capacity of a square foot of heating surface to absorb heat is not increased by the increase in quantity of the gas that passes under it, although it may be increased by the increase of the difference between the temperature of the gas and that of the water in the boiler. The reduction in temperature of the gas in the consecutive sections may now be as follows:

| | | | | | | | | | |
|------------------|-------|------|------|------|------|------|------|------|------|
| Section No..... | 2 | 3 | 4 | 5 | 6 | 7 | 8 | 9 | 10 |
| Temperature F... | 2300 | 1920 | 1670 | 1490 | 1360 | 1250 | 1160 | 1090 | 1030 |
| Reduction..... | | 380 | 250 | 180 | 130 | 110 | 90 | 70 | 60 |

Comparing these two statements of the temperature in the different sections, we note several things:

1. In the first case the temperature of 2600° at the furnace is reduced to 730° at the chimney, and in the second case the same temperature at the furnace is reduced only to 1030° at the chimney. In the first case the temperature at the chimney indicates a loss of heat in the chimney gases of $730 \div 2600 = 28$ per cent of the heat in the furnace. In the second case the temperature of 1030° indicates the loss of $1030 \div 2600 = 39.6$ per cent.

2. In the second case the reduction of the temperature in the first three sections is less than that of the corresponding section in the first case. This does not mean that the heat transmitted is less in the second case than in the first, for the quantity of gas has been increased and there is a greater quantity of heat transmitted while the reduction in temperature is less.

3. In each section in the second case the temperature is greater than in the corresponding section in the first case. The difference between the temperature of the gas and the water is greater, consequently the transmission of heat is greater, and the quantity of steam made by the boiler is greater. The capacity of the boiler therefore depends to a considerable extent on the economy. Increasing the quantity of coal burned increases the capacity while it reduces the economy.

4. Although in the second case a greater quantity of steam is made than in the first, it is not made with the same economy of fuel, for the temperature of the chimney gases is greater, showing that a greater percentage of the heat generated in the furnace has been wasted.

5. Since the reduction of temperature in any section is less than that in the preceding section, it is evident that in the first case an ad-

dition of a few sections to the length cannot add much to the economy of fuel. In the second case, however, the temperature of the chimney gases being 1030° , it is evident that an addition of several sections to the length might be made before the gases would be reduced to 730° , the temperature of the chimney gases in the first case. It is also evident that increasing the heating surface increases both the capacity and the economy.

Loss of Economy Due to Insufficient Heating Surface.—What has been said above shows the necessity of proportioning the heating surface to the amount of coal to be burned, rather than to the extent of grate-surface; and so proportioning it as to give such an extent of heating surface as will reduce the temperature of the chimney gases to say within 100° or 200° of the temperature of the steam, if economy of fuel is desired.

Some readers may think that all this is so very simple that there should be no need of explaining it at so great length. It all amounts to the simple statement that economy of fuel requires that the temperature of the escaping gases should be low, and that, to secure this low temperature, plenty of heating surface should be given. This is quite true, but it is not at all appreciated by many boiler users. Many of them never think of putting a pyrometer or a thermometer in the stacks of their boilers, to discover by that means whether or not there is a waste of fuel. They are quite satisfied if their boilers give all the steam that is required, and pay little attention to the cost of producing that steam. It has therefore seemed desirable that this chapter should contain not only the simple statement above given, but also in considerable detail the reasoning upon which the statement is founded. A mathematical treatment of the subject will be found in the chapter on "Efficiency of Heating Surface."

To come now to a more definite statement of how great is the loss due to insufficient heating surface, we must have recourse to the records of experiments upon boilers.

In a paper on "Efficiency of Boiler Heating Surface," by Mr. R. S. Hale, Trans. Am. Soc. M. E., vol. xviii., he gave a diagram showing the relation of the evaporation from and at 212° per pound of combustible to the evaporation from and at 212° per square foot of heating surface per hour, as obtained by plotting the results of tests with anthracite coal given in Mr. Geo. H. Barrus's book on "Boiler Tests." This diagram is here reproduced, Fig. 43. The small circles represent the results of each individual test, the lower curve represents

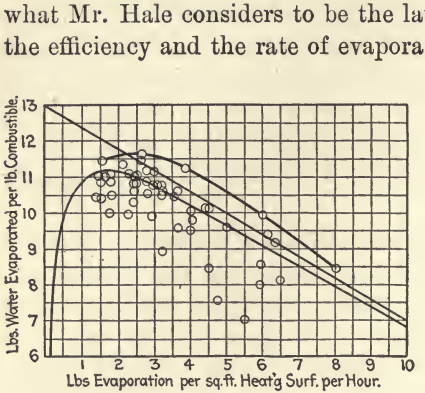

FIG. 43.

what Mr. Hale considers to be the law of the average relation between the efficiency and the rate of evaporation, and the upper line, passing through five of the small circles, is a line which is added to represent the law of the relation as derived from maximum results. It will be noticed how very far below the maximum are some of the individual results.

Maximum Possible Economy. — On another diagram, Fig. 44, is plotted together with this curve of Mr. Barrus's maximum results another curve

representing the maximum results obtained in the boiler tests made

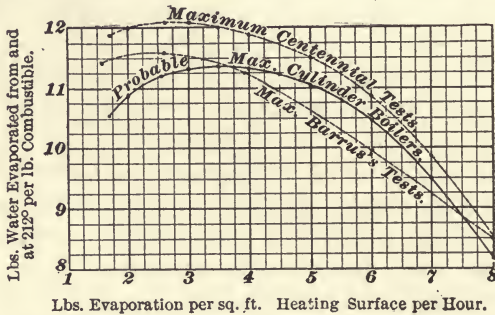

FIG. 44.—RELATION OF ECONOMY TO RATE OF DRIVING.

at the Centennial exhibition in 1876. The particular results through which the curve is drawn are the following:

| Name of Boiler. | Lbs. Water Evaporated from and at 212° per sq. ft. H. S. per Hour. | Lbs. Water Evaporated from and at 212° per lb. Combustible. |
|-----------------|--|---|
| Firmenich..... | 1.932 | 11.938 |
| Root..... | 2.586 | 12.094 |
| Smith..... | 3.739 | 11.985 |
| Galloway..... | 5.413 | 11.216 |
| Pierce..... | 6.698 | 9.865 |

The smooth curve passes directly through the first four of the above results and a little above the fifth, joining the curve of Mr. Barrus's result at its right-hand extremity.

As the Centennial tests were made under exceptionally favorable conditions, and as the maximum results of these tests have never been surpassed in other competitive tests with anthracite coal in which every precaution was taken by impartial observers to secure accuracy, it is fair to consider this curve as representing the highest possible evaporation in any form of boiler for the several rates of evaporation per square foot of heating surface here given. Taking approximate values along different portions of the curve we have the following:

POUNDS OF WATER EVAPORATED FROM AND AT 212°.

| | | | | | | | | | | | |
|--|------|----|------|------|-----|-------|------|------|------|-----|-----|
| Per. sq. ft. of heating surface per hour.. | 1.7 | 2 | 2.5 | 3 | 3.5 | 4 | 4.5 | 5 | 6 | 7 | 8 |
| Per lb. of combustible | 11.9 | 12 | 12.1 | 12.1 | 12 | 11.85 | 11.7 | 11.5 | 10.8 | 9.8 | 8.5 |

The Centennial tests were all made upon other forms of boiler than the plain cylinder, and the same is true of Mr. Barrus's tests. There is no record published of any comprehensive series of tests upon plain cylinder boilers from which we might draw a curve expressing the relation of the efficiency to the rate of evaporation, but we may make certain reasonable assumptions concerning them which may enable us to draw a probable curve.

The first assumption is that the form of the plain cylindrical boiler is exceedingly favorable to the absorption of the greatest possible quantity of heat by every square foot of its heating surface. The flames and heated gases travel steadily along this surface, the tendency of heated gases always to ascend tending continually to keep the hottest portion of the gas in contact with the surface above it. There is no shorter path by which the gases may reach the chimney; hence, there is no tendency to short-circuiting the gases, which is a serious defect in many other forms of boiler. The thickness of the metal in the shell, rarely more than $\frac{1}{4}$ inch, is not so great as to cause an appreciably greater resistance to the passage of heat through it than that through the thin tubes of tubular boilers. The form of the plain cylinder boiler seems, therefore, to be as well adapted to the absorption of heat as that of any other boiler, and there seems to be every reason to believe that, as far as the absorption of heat through its shell from the heated gases is concerned, it should be quite as efficient as the best of the boilers tested at the Centennial exhibition, and that the curve expressing its maximum results would follow closely the curve of maximum results of the Centennial tests, unless there is some other cause not yet considered which would prevent it.

Loss of Heat by Radiation.—There is such a cause, and that brings us to the second assumption, viz.: that the radiation loss of the plain cylinder boiler is very much greater than that of the modern types of boiler which were tested at the Centennial exhibition. The cylinder boiler, 30 ft. long and 30 in. diameter and having 120 sq. ft. of heating surface, will have approximately 120 sq. ft. in the upper half of its shell covered with a non-conducting covering, more or less imperfect, and the two brick side walls would be about 240 sq. ft. These two side walls, however, might be used for a battery of three or four boilers, as in Fig. 45. A return tubular boiler of double the diameter and half the length of the cylinder boiler, or 5×15 ft., would have only about

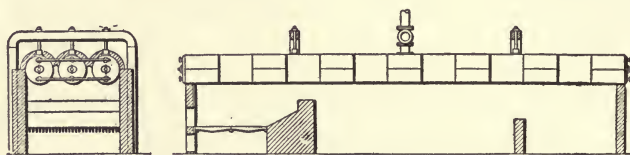

FIG 45.—BATTERY OF PLAIN CYLINDER BOILERS.

80 sq. ft. of the upper portion of its shell covered with a non-conductor, and about 240 sq. ft. side walls, which might also be used for a battery of boilers. But the tubular boiler might have, say, 60 4-in. tubes inside of it, with a total heating surface of about 940 sq. ft., which are entirely surrounded by water, and therefore contribute nothing to the loss by external radiation. The total heating surface of the tubular boiler would be about 1100 sq. ft., or nine times as great as that of the cylinder boiler, and yet would expose less surface to external radiation, so that the loss of heat by radiation from the cylinder boiler must be much greater than from the tubular boiler. How much greater we have no means of knowing, in the absence of direct experiments. Mr. Hale, in the paper before mentioned, in discussing tests with other boilers than plain cylindrical, says that the radiation in some of these tests could not have been over 2 per cent when the boilers were driven at a rate of evaporation of 3 lbs. of water per sq. ft. of heating surface per hour, and that "it does not seem possible that the radiation could in modern practice have gone up to much over 6 or 7 per cent at most, and it is probable that it is not over 5 per cent if it is as much as that." The "modern practice" referred to by Mr. Hale is not practice with plain cylinder boilers, which latter may be called ancient practice, since plain cylinder boilers are now used in only a few localities. We will probably not be far from correct if we assume that the

radiation from plain cylinder boilers is 5 per cent greater than from the boilers tested at the Centennial exhibition, when the calculation of the radiation is made on the basis of the rate of evaporation being 3 lbs. per sq. ft. of heating surface per hour, this 5 per cent being that percentage of the total heating value of the pound of combustible. This heating value, 14,600 B.T.U., being equal to an evaporation of 15.2 lbs. of water, 5 per cent of this is 0.76 lb., which we may assume to be the extra loss by radiation in a plain cylinder boiler over that in a modern type of boiler when the rate of evaporation is 3 lbs. per sq. ft. of heating surface per hour. When the rate of evaporation is doubled the percentage will be halved, and the extra loss by radiation will then be 0.38 lb. If the rate of evaporation is less than 3 lbs. the percentage loss will be greater. Subtracting the extra loss as calculated from the figures already given as taken from the curve of maximum results of the Centennial tests we have the following:

MAXIMUM ECONOMY OF PLAIN CYLINDER BOILERS: POUNDS WATER EVAPORATED FROM AND AT 212°.

| Per square foot heating surface per hour... .. | 1.7 | 3 | 3.5 | 4 | 5 | 6 | 8 |
|---|-------|-------|-------|-------|-------|-------|------|
| Per lb. combustible, max. of other boilers Centennial tests | 11.90 | 12.05 | 12.00 | 11.85 | 11.50 | 10.85 | 8.50 |
| Subtract extra radiation loss for cylinder boilers..... | 1.34 | .76 | .65 | .57 | .46 | .38 | .28 |
| Probable maximum per lb. combustible, cylinder boilers..... | 10.56 | 11.29 | 11.35 | 11.28 | 11.04 | 10.47 | 8.22 |

The figures in the last line have been plotted in the diagram, Fig. 44, and a curve drawn through them. It will be seen that the maximum economy is at a rate of combustion of 3.5 lbs. per square foot of heating surface, that below this rate the economy is decreased on account of the loss by radiation, and that above this rate the economy falls, at first slowly, and later very rapidly, until at a rate of evaporation of 8 lbs. per square foot of heating surface per hour the evaporation is only 8.22 lbs. per lb. of combustible, as compared with the maximum of 11.35 lbs. at a rate of 3.5 lbs.

Beyond the rate of 8 lbs. per square foot we have no experimental data upon which to base conclusions. If the direction of the curve between 7 and 8 lbs. were continued in a straight line, as the shape of the curve seems to indicate, there would be a decrease in the evaporation per lb. of combustible of about 1.3 lbs. for every increase of 1 lb.

in the rate, and the curve would cut the line representing 0 lbs. evaporation per pound combustible at a rate of a little over 14 lbs.

Capacity of a Plain Cylinder Boiler at Different Rates of Driving.

—We now have the data from which to calculate the probable amount of steam that will be made by the plain cylinder boiler, of the size selected, at different rates of driving.

PROBABLE MAXIMUM WORK OF A PLAIN CYLINDRICAL BOILER OF 120 SQ. FT. HEATING SURFACE AND 12 SQ. FT. GRATE SURFACE AT DIFFERENT RATES OF DRIVING.

| | | | | | | | |
|---|-------|-------|-------|-------|-------|-------|-------|
| Rate of driving; lbs. water evaporated per sq. ft. of heating surface per hour..... | 1.7 | 3 | 3.5 | 4 | 5 | 6 | 8 |
| Total water evaporated by 120 sq. ft. heating surface, per hour, lbs..... | 204 | 360 | 420 | 480 | 600 | 720 | 960 |
| Horse-power; 34.5 lbs. per hour = 1 H.P. | 5.83 | 10.43 | 12.17 | 13.91 | 17.39 | 20.87 | 27.83 |
| Pounds water evaporated per pound combustible | 10.56 | 11.29 | 11.35 | 11.28 | 11.04 | 10.47 | 8.22 |
| Pounds combustible burned per hour..... | 19.3 | 31.9 | 37.0 | 42.6 | 54.3 | 68.8 | 116.8 |
| Pounds combustible per hour per sq. ft. of grate..... | 1.61 | 2.66 | 3.08 | 3.55 | 4.52 | 5.73 | 9.73 |
| Pounds combustible per hour per horse-power..... | 3.31 | 3.06 | 3.04 | 3.06 | 3.12 | 3.30 | 4.16 |

From the figures in the last line we see that the amount of fuel required for a given horse-power is nearly 37 per cent greater when the rate of evaporation is 8 lbs. than when it is 3.5 lbs.

The figures in the above table which represent the economy of fuel, viz., "Pounds water evaporated per pound combustible," and "Pounds combustible per hour per horse-power," are what may be called "maximum" results, and they are the highest that are likely to be obtained with anthracite coal with the most skillful firing and with every other condition most favorable. Unfavorable conditions, such as poor firing, scale on the inside of the heating surface, dust or soot on the outside, imperfect protection of the top of the boiler from radiation, leaks of air through the brickwork, or leaks of water through the blow-off pipe, may greatly reduce these figures.

Disadvantages of the Plain Cylinder Boiler.—An inspection of the figures will reveal one of the reasons why in most parts of the world the plain cylinder boiler is no longer used. The boiler we have selected for illustration is of quite large size, 30 feet long, 2½ feet wide, occupies a considerable area of ground, and requires quite a costly setting; yet when driven at its most economical rate, it develops only 12.17 H.P., or when driven at such a rate that its fuel consumption per H.P. is 37 per cent greater than at its most economical rate,

it develops only 27.83 H.P. It can be made to develop a still greater horse-power, but only by a much greater waste of fuel. Where fuel has no marketable value, such as sawdust and waste lumber at saw-mills, refuse coal at coal-mines, and the like, the question of fuel economy is of no importance; but even in such cases, in which, say, 10 or more pounds of water may be evaporated per square foot of heating surface per hour, equal to 35 H.P. developed by a boiler of 120 sq. ft. heating surface, it is probable that the first cost of the plain cylinder boiler, including setting, is greater than that of some more modern form of boiler. Where refuse coal is used as fuel, the cost of hauling it and the cost of removal of ashes should be considered, and it may be found that these costs alone, even when fuel costs nothing, justify the use of a boiler which economizes fuel.

Suppose a plant of boilers at a coal-mine is used to generate 1000 H.P. of steam. Refuse coal is used, and the boilers are driven at such a rate that 4 tons of coal are used for every 3 tons that would be used by boilers driven at an economical rate. It requires four men to handle the coal and ashes, while only three men would be required with the economical boiler-plant. The saving of one man's wages, say, \$450 per year, is equal to 5 per cent on an investment of \$9000, or 10 per cent on an investment of \$4500. So, if the economical boiler-plant of 1000 H.P. did not cost over \$4000 above that of an uneconomical boiler-plant, its purchase would be justified from a financial standpoint even in a case where fuel costs nothing.

In places where plain cylinder boilers are still used, two points are especially claimed in their favor: First, their simplicity of construction, and, second, the fact that they are easily cleaned from scale by a man getting inside of them with hammer and chisel. The first point may be admitted without question. As for the second, it may be said that some other forms of boiler are kept free from scale as easily as the cylinder boiler, and that it is generally found better in modern practice to prevent the formation of scale than to allow it to form and then go to the trouble of removing it by hand labor. Whatever may be the merits of the plain cylinder boiler in regard to the two points mentioned, they are more than offset by their numerous disadvantages.

Besides the objections to the plain cylinder boiler already spoken of, viz., great first cost when driven at an economical rate, great waste of fuel when forced much beyond this rate, and excessive ground space occupied, there are others, some of which the plain cylinder boiler holds in common with other styles. The first of these objections,

which is common to all very long boilers, is the difficulty of supporting them in such a manner that excessive strains are not created in the sheets and rivets by the weight of the boiler and the water inside of it, in addition to the strain due to the pressure of steam. When a long boiler is suspended from two points, whether located at the ends or at some distance from them, the stresses due to weight, which tend to rupture the boiler by bending it, may be calculated; but when supported at three or more points the stresses are indeterminate—one support may sustain much more weight than the other—and the strain on some portion of the shell or riveted seams may be greater than a proper regard for safety would admit. These strains are apt to be changed in amount or in direction, as from tension to compression, or *vice versa*, with the changes in temperature in boiler and setting which take place when the boiler is put into or out of service. Even if the maximum strains due to the weight of the boiler may not of themselves be sufficient to endanger the safety of the boiler when new, their continuance during a period of years may make the iron hard and brittle, and hence give rise to danger; or the iron may in time become weakened by corrosion, and then the strains caused by weight of the boiler may become dangerous.

Saving Waste Heat of the Plain Cylinder Boiler.—The chief faults of the plain cylinder boiler, its deficiency of heating surface and high first cost compared to its capacity when driven at anything like an economical rate, have led, as already stated, to its general abandonment wherever the cost of fuel is a matter of importance. In some old plants, however, where cylindrical boilers are already in use, and when they are still in good condition to furnish steam of the pressure desired, but are driven at such a rate as to be wasteful in fuel, it has been found economical, instead of replacing the old boilers with new ones, to add to them an “economizer” in which a large part of the waste heat may be saved.

Use of a Water-tube Boiler as an Addition to a Cylinder Boiler.—Sometimes it is found that the waste gases from a cylinder boiler are so high in temperature that they may be advantageously utilized by passing them into another boiler. Several of the modern forms of water-tube boiler may thus be used. An instance of the kind is described in a catalogue (1897) of the Morrin “Climax” boiler. The gases escaping from a plant of twelve cylinder boilers 30 ft. long, 30 ins. diameter, located at No. 2 shaft at Nanticoke, Pa., ranged from 1500° F. with the blowers off to 2000° with the blowers on. A 400-

H.P. Climax boiler, 26½ ft. high, 11 ft. 2 ins. diameter, containing 3940 sq. ft. of heating surface, was placed between the two stacks that carried off the waste gases from the twelve boilers. Two brick flues conducted the gases to the Climax boiler, the outlet to the old stack being cut off by iron doors. A test made when No. 2 buckwheat coal was used under the cylinder boilers showed that the Climax boiler, driven by the waste gases alone, developed 526.7 H.P., or over 30 per cent more than its own rating. The temperature of the gases after they had passed through the Climax boiler was 520°. It is stated concerning this result that when cylinder boilers are used it is possible to double their capacity without using an ounce more coal, or employing another hand. This would be possible only, of course, when the temperature of the gases leaving the cylinder boilers is very high, say 1500° F. or over.

At one of the Philadelphia & Reading collieries, one 250 H.P. Cahall vertical boiler was placed at the rear of twelve plain cylinder boilers of the ordinary dimensions common in anthracite colliery practice. A simultaneous test was made, in 1896, by J. M. Whitham, of the performance of the cylinder boilers and the Cahall boiler. Mr. Whitham summarized his results as follows:

1. The cylinder boilers are run to develop from 33 to 35 H.P. each.

2. The cylinder boilers by themselves evaporate 3.77 lbs. of water from and at 212° per lb. of dry coal.

3. The combination of cylinder boilers and Cahall boilers, the latter using waste heat only, permits an evaporation of 6.98 lbs. of water from and at 212° per lb. of dry coal.

4. The waste gases enter the Cahall setting at about 1600° F., and leave it about 700°.

5. The use of waste gases by the Cahall boiler increases the available horse-power of the plant from 74 to 85 per cent, according to the number of boilers used for supplying the waste heat.

6. The 250-H.P. Cahall boiler using waste gases from eight cylinder boilers developed 207.6 boiler H.P., and when supplied by twelve boilers, it developed 334.1 H.P., or 33.6% above its rating.

7. The fuel used, called a "rice mixture," consisted of 20% slate pickings, 8% buckwheat, 46% rice-coal, and 26% dirt. It contains, as used at this colliery, from 6.25 to 9.5 per cent moisture, and from 32.4 to 34 per cent ash and refuse. It is burned with a strong fan-blast.

Modern Boiler Practice in the Anthracite Coal Regions.—In the anthracite coal regions plain cylinder boilers are still (1901) used in the majority of mining plants, but as they become worn out they are being replaced by other styles. The common horizontal return tubular boiler has been largely adopted, chiefly, no doubt, on account of its low first cost, while of the water-tube boilers, the Babcock & Wilcox, the National, the Cahall, the Stirling, and the Climax are all represented.

CHAPTER IX.

EFFICIENCY OF THE HEATING SURFACE.

ASSUMING that the fuel is burned completely in the furnace, generating a quantity of hot gas, which contains all the heat produced by the combustion, we now have to consider what proportion of this heat is absorbed by being transmitted through the metal heating surface of the boiler into the water; in other words, what is the efficiency of the heating surface. This will depend not only on the nature, extent, and arrangement of the heating surface, that is, on the boiler itself, but also on the rate at which it is driven, and on other conditions of its operation. A theoretical discussion of the subject will first be given, and then the relation of the theory to practice will be shown.

NOTATION.

S = area of heating surface in sq. ft.

W = actual water evaporated, lbs. per hour, reduced to equivalent evaporation from and at 212° , or U.E.* per hour.

W' = same when radiation is so small that it may be neglected, or $W +$ radiation, in U.E. per hour.

K = heating value of the fuel in B.T.U. per lb.

F = fuel used, lbs. per hour.

f = weight of gases per lb. of fuel.

$w = Ff$, = weight of dry gases, lbs. per hour.

c = specific heat of gas, considered as a constant.

t = excess of the temperature of the water in the boiler above the atmospheric temperature.

T = temperature (above atmosphere) of the gas in contact with some given portion of the heating surface.

T_1, T_2 = initial and final values of T .

* U.E. = units of evaporation.

cwT_1 = total heat supplied to the gas by the burning of the fuel, on the supposition that all of the heat generated is first utilized in raising the temperature of the gas before it comes in contact with the heating surface.

cwT_2 = heat lost in the gases escaping to the chimney.

a = a coefficient of resistance to transmission of heat, and of other elements of inefficiency, more fully explained later.

E_p = possible evaporation, in U.E. per lb. of fuel if all the heating value of the fuel were utilized.

E_a = actual evaporation, in U.E. per lb. of fuel.

E_a' = same when radiation is not taken into account, or $E_a +$ radiation, in U.E. per lb. of fuel.

R = radiation in U.E. per sq. ft. of heating surface per hour.

In what follows we shall at first consider the radiation so small that it may be neglected.

$$\text{Efficiency of the heating surface} = \frac{E_a'}{E_p} = \frac{cw(T_1 - T_2)}{cwT_1} = \frac{T_1 - T_2}{T_1}. \quad (1)$$

This fraction is the ratio of the heat absorbed by the boiler to the heat supplied by the fuel.*

q = rate of conduction in U.E. per hour per sq. ft. of heating surface, corresponding to any difference of temperature $T - t$ of the gas and of the water.

$q dS$ = heat transmitted per hour through any small portion dS of the heating surface.

$cw dT$ = heat lost by the gas in passing over the portion of heating surface dS ; $q dS = cw dT$.

After the hot gas passes over the elementary portion dS of the heating surface, losing the temperature dT , it arrives at the next equal elementary portion with a diminished temperature, and transmits heat through it at a diminished rate, since the rate of conduction q decreases in some ratio with the decrease of the difference of temperature $T - t$; and so on, transmitting a less and less quantity through each successive equal portion of surface, until it finally leaves the heating surface at the temperature T_2 .

* Rankine uses a different expression for efficiency, viz., $\frac{T_1 - T_2}{T_1 - t}$, or the ratio of the heat absorbed to the heat which would be absorbed if the gases were cooled down to the temperature of the water in the boiler. This is not as convenient as the expression used above, and it is not in harmony with the usual definition of efficiency, viz., energy utilized \div energy supplied.

For the whole heating surface S , and the corresponding decrease of temperature of the hot gas from T_1 to T_2 , we have the integral of the above differential expression:

$$cw(T_1 - T_2) = \int q dS,$$

or

$$\frac{S}{cw} = \int_{T_2}^{T_1} \frac{dT}{q} \dots \dots \dots (2)$$

The second member of this last equation may be integrated when we find the law of the relation of q to $T - t$.

Rankine represents these principles graphically as follows:

Draw AD , Fig. 46, to represent the whole heating surface S , and let any portion of that line, as AX , represent s , a part of that surface. Let $AB = q_1$, the rate of conduction for the initial temperature T_1 . In DA produced, take $AO = \frac{cw(T_1 - t)}{q_1}$; then the rectangle

$OABC$ will equal the whole heat of the hot gas proceeding from the furnace per hour, measured above the temperature t ; for

$$AO \times AB = AO \times q_1 = cw(T_1 - t).$$

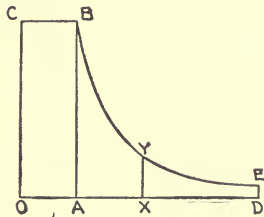

FIG. 46.

Let $XY = q =$ the rate of conduction corresponding to the temperature of the gas after having passed over the portion AX of the heating surface, and let BYE be a curve drawn through the summits of a series of such ordinates; then the area of any part of that curve, such as $ABYX$, represents the heat transferred per hour through the part AX of the heating surface; and the area $ABED$ the heat transferred through the whole surface AD ; and when the curve BYE is produced indefinitely, the area contained between it and its asymptote, AD produced, approximates indefinitely to that of the rectangle $OABC$.

The definite results of these principles depend on the relation between q and T_1 .

For small differences of temperature it is found experimentally that the rate of transmission of heat through metal plates is nearly proportional to the difference of temperature of the fluids on the two sides of the plate, but for great differences of temperature, such as

those existing in steam-boiler furnaces, the transmission increases at a faster rate than the difference of temperature, so that it is nearly proportional to the square of the difference, as is shown by Blechynden's experiments, which will be described later. Rankine gives $q = \frac{(T-t)^2}{a}$, in which a is a coefficient whose value may be determined by experiment, and he gives its value as from 160 to 200. The method of deducing the value of a from data of experiments on steam-boilers will be given later; and it will also be shown that it is a function of other things besides the resistance of the metal to the transmission of heat.

Using this value of q we have

$$\frac{S}{cw} = a \int_{T_2}^{T_1} \frac{dT}{(T-t)^2} \dots \dots \dots (3)$$

Whence*

$$\frac{S}{cwa} = \frac{1}{T_2 - t} - \frac{1}{T_1 - t} = \frac{T_1 - T_2}{(T_2 - t)(T_1 - t)} \dots \dots \dots (4)$$

By combining equations (1) and (4) we may obtain

$$\frac{E_a'}{E_p} = \frac{(T_1 - t)^2 \div T_1}{(T_1 - t) + \frac{acw}{S}} = \frac{(T_1 - t)^2 \div T_1}{(T_1 - t) + \frac{acfF'}{S}} \dots \dots \dots (5)$$

in which equation T_2 has disappeared. (Appendix, note 2.) Let $\frac{T_1 - t}{T_1} = B$, and $\frac{acf}{T_1 - t} = A$; $acf = (T_1 - t)A$. Then (5) becomes

$$\frac{E_a'}{E_p} = \frac{(T_1 - t)B}{(T_1 - t) + (T_1 - t)\frac{AF'}{S}} = \frac{B}{1 + \frac{AF'}{S}} \dots \dots \dots (6)$$

$$BE_p = E_a' + E_a' \frac{AF'}{S}, = E_a' + \frac{E_a' AW'}{SE_a'}, \text{ since } F' = \frac{W'}{E_a'}$$

Hence
$$E_a' = BE_p - \frac{AW'}{S}, \dots \dots \dots (7)$$

which is the equation of a straight line if E_a' and $\frac{W'}{S}$ are variables. It shows that the evaporation per pound of fuel is a function of the rate

* See note 1, appendix to this chapter.

of evaporation per square foot of heating surface, and is affected by two coefficients, A and B .

B , being a function of the initial temperature of the gas T_1 , depends on the heating value of the fuel and on the volume of gas, that is, on the air-supply. Let K = heat-units per lb. of fuel burned, = T_1fc . Then

$$B = \frac{T_1 - t}{T_1} = \frac{\frac{K}{fc} - T}{\frac{K}{fc}} = \frac{K - tcf}{K}, \dots \dots (8)$$

and

$$A = \frac{acf}{T_1 - t} = \frac{ac^2f^2}{K - tcf}; \dots \dots \dots (9)$$

expressions from which we may find the value of A and B when the heating value of the coal, the temperature of the water in the boiler, the weight of gas per lb. of fuel, and the specific heat of the gas are known. The value of A , however, depends upon that of the experimental coefficient a .*

Values of the Coefficients B and A.

If in the equations $B = \frac{K - tcf}{K}$ and $A = \frac{ac^2f^2}{K - tcf}$, we substitute assumed numerical values as follows: K = 13,000, 14,000, and 15,000; t = 250 and 300; c = 0.24; f = 20, 30, and 40; a = 200, 300, and 400, we obtain values of B and A as follows:

$$\text{Values of } B = \frac{K - tcf}{K}.$$

| | | | | | | |
|--------------------|---------------------|------|------|------|------|------|
| | For $t = 250^\circ$ | 250° | 250° | 300° | 300° | 300° |
| | $f = 20$ | 30 | 40 | 20 | 30 | 40 |
| For $K = 13,000$, | $B = .91$ | .86 | .82 | .89 | .83 | .78 |
| = 14,000, | $B = .91$ | .87 | .83 | .90 | .85 | .79 |
| = 15,000, | $B = .92$ | .88 | .84 | .90 | .86 | .81 |

* Up to this point the treatment of this subject is based partly on that of Rankine ("Steam-engine," p. 262) and partly on that of Ha'e (Trans. A. S. M. E., vol. xviii. p. 330). What follows is original work of the author.

$$\text{Values of } A = \frac{ac^3f^2}{K - tcf}.$$

| | For $t = 250^\circ$ | 250° | 250° | 300° | 300° | 300° |
|--------------------------------|---------------------|------|------|------|------|------|
| | $f = 20$ | 30 | 40 | 20 | 30 | 40 |
| For $K = 13,000, a = 200, A =$ | .39 | .92 | 1.74 | .40 | .95 | 1.82 |
| | $= 300, A =$ | .59 | 1.39 | 2.61 | .60 | 1.43 |
| | $= 400, A =$ | .78 | 1.85 | 3.48 | .80 | 1.91 |
| For $K = 14,000, a = 200, A =$ | .36 | .85 | 1.59 | .37 | .87 | 1.66 |
| | $= 300, A =$ | .54 | 1.27 | 2.38 | .55 | 1.31 |
| | $= 400, A =$ | .72 | 1.70 | 3.18 | .73 | 1.75 |
| For $K = 15,000, a = 200, A =$ | .33 | .79 | 1.46 | .34 | .81 | 1.53 |
| | $= 300, A =$ | .50 | 1.18 | 2.19 | .51 | 1.21 |
| | $= 400, A =$ | .67 | 1.57 | 2.93 | .68 | 1.61 |

Graphical Interpretation of Formula (7).—On a system of rectangular co-ordinates, Fig. 47, lay out E_p and BE_p as ordinates and $\frac{W'}{S}$ as abscissa. From the end of the ordinate BE_p draw a straight line inclining downwards at an angle whose tangent is A . Then for any value of the abscissa $\frac{W'}{S}$ the corresponding value of E_a' will be the length of the ordinate drawn from the extremity of $\frac{W'}{S}$ to the inclined line. The inclined line can never reach the axis of abscissas, and the rate of evaporation $\frac{W'}{S}$ can never be as great as $\frac{BE_p}{A}$. (Appendix, note 3.)

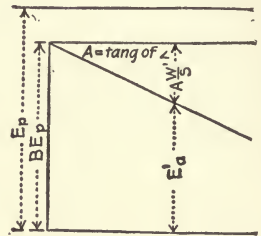

FIG. 47.

Radiation Considered.—In the above formulas no account has been taken of radiation into the atmosphere from the external walls of the boiler and furnace. For a given value of F and S radiation will tend to reduce the values of E_a' and W' . Let r = radiation expressed in units of evaporation per lb. of fuel, then total radiation per hour = rF , and radiation in U.E. per hour per sq. ft. of heating surface = $\frac{rF}{S} = R$.

$$E_a' = E_a + r. \quad W' = W + RS.$$

Formula (7) then becomes

$$E_a = BE_p - A \left(\frac{W}{S} + R \right) - r. \dots (10)$$

For a given temperature t of the water in the boiler and ordinary

furnace conditions, rF and R will be practically constant. They will represent but a small percentage of the heat generated in the furnace when the rate of driving is high, and a large percentage when the rate becomes very low.

Graphical Representation of Formula (10).—Formula (10) may be

expressed $E_a = BE_p - A\frac{W}{S} - AR - r$,

and it may be represented graphically as in Fig. 48, the height E_a of any point of the curved line above the base line representing the actual evaporation corresponding to a certain rate of evaporation W/S . In the equation there are three quantities which are subtracted from BE_p , and these are shown on the diagram: AR , a constant; $A\frac{W}{S}$, which increases directly as W/S ; and $r = RS/F$, which increases rapidly as W/S approaches 0. When W/S and $E_a = 0$, $r = BE_p - AR$.

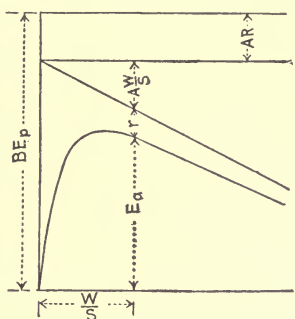

FIG. 48.

Efficiency when Radiation is Considered.—We have

$$r = \frac{RS}{F} = \frac{RSE_a}{W}, \quad \text{since } R = \frac{rF}{S} \quad \text{and} \quad F = \frac{W}{E_a}.$$

Substituting this value of r in eq. (10) it becomes

$$E_a = BE_p - A\left(\frac{W}{S} + R\right) - \frac{RSE_a}{W} = \frac{BE_p}{1 + \frac{RS}{W}} - A\frac{W}{S}. \quad (11)$$

(See Note 4, Appendix.)

$$\text{Efficiency} = \frac{E_a}{E_p} = \frac{B}{1 + \frac{RS}{W}} - \frac{AW}{SE_p}. \quad (12)$$

An Arithmetical Example.—Consider first the case in which radiation is so small that it may be neglected. We will suppose the following data to have been obtained in a test of a boiler, and assume that all the fuel is completely burned, the whole of the heat generated being first applied to raising the temperature of the gases of combustion before they come in contact with the heating surface:

Heating value of the fuel = $K = 13,570$ B.T.U. per lb.;

$$E_p = 13,570 \div 965.7 = 14.05 \text{ U.E. per lb. of fuel,}$$

$S = 1000$ sq. ft.; $F = 300$ lbs. per hour;
 $W = 75\%$ of $14.05 \times F = 10.538 \times 300 = 3161$ lbs. per hour;

$f = 24$ lbs. gas per lb. fuel; $c = 0.24$, specific heat;

$w = Ff = 7200$ lbs. gas per hour.

$T_1 = \frac{K}{fc} = \frac{13,570}{5.76} = 2356^\circ$ elevation above atmospheric temperature;

$\frac{T_1 - T_2}{T_1} = 75\%$ efficiency; $T_2 = 25\%$ of $2356 = 589^\circ$;

$t =$ temperature of water — atmospheric temperature,
 $= 341^\circ \text{ F.} - 60^\circ = 281^\circ$;

$T_1 - T_2 = 1767^\circ$; $T_1 - t = 2075^\circ$; $T_2 - t = 308^\circ$.

We now have all the values required for substitution in formula (4) except a .

Formula (4) is

$$\frac{S}{cwa} = \frac{1}{T_2 - t} - \frac{1}{T_1 - t} = \frac{T_1 - T_2}{(T_2 - t)(T_1 - t)}.$$

Substituting the values, we have

$$\frac{1000}{0.24 \times 7200 \times a} = \frac{1}{308} - \frac{1}{2075} = \frac{1767}{308 \times 2075}.$$

Whence $a = 209.3$.

Take now formula (7), $E_a' = BE_p - A \frac{W'}{S}$.

$$B = \frac{T_1 - t}{T_1} = \frac{2075}{2356} = 0.8807;$$

$$A = \frac{acf}{T_1 - t} = \frac{209.3 \times 0.24 \times 24}{2075} = 0.581$$

or, from eq. (8), $B = \frac{K - tcf}{K} = \frac{13,570 - 281 \times 0.24 \times 24}{13,570} = 0.8807$;

and eq. (9), $A = \frac{ac^2f^2}{K - tcf} = \frac{209.3 \times 0.24^2 \times 24^2}{13,570 - 1619} = 0.581$.

$$E_a' = BE_p - A \frac{W'}{S} = 0.8807 \times 14.05 - 0.581 \frac{3161}{1000} = 10.538.$$

$$\frac{E_a'}{E_p} = \frac{10.538}{14.05} = 75\% \text{ efficiency.}$$

2. We will now assume that radiation from the boiler and furnace amounts to 2% of the heating value of the fuel, reducing the efficiency to 73% instead of 75.

$$2\% \text{ of } E_p = 14.05 \times .02 = 0.281 = r.$$

$$R = \frac{rF}{S} = \frac{0.281 \times 300}{1000}$$

$$= 0.0843 \text{ U.E. per hour per sq. ft. of heating surface.}$$

$$W = W' - RS = 3161 - 84 = 3077.$$

$$\begin{aligned} \text{Formula (11), } E_a &= \frac{BE_p}{1 + \frac{RS}{W}} - A \frac{W}{S} = \frac{0.8807 \times 14.05}{1 + \frac{84.3}{3077}} - 0.581 \frac{3077}{1000} \\ &= 10.256 \text{ U.E. per lb. fuel.} \end{aligned}$$

$$\begin{aligned} \text{Formula (12), Efficiency, } \frac{E_a}{E_p} &= \frac{B}{1 + R \frac{S}{W}} - \frac{A W}{S E_p} \\ &= \frac{0.8807}{1 + \frac{84.3}{3077}} - \frac{0.581 \times 3077}{1000 \times 14.05} = 0.73. \end{aligned}$$

NOTE.—If the fuel contains hydrogen and water, the values of B and A should be obtained respectively from $\frac{T_1 - t}{T}$ and $\frac{acf}{T_1 - t}$ and not from eqs. (8) and (9), since the value of K in these equations, determined from the analysis, is the total heating value, the water in products of combustion being condensed and cooled to the atmospheric temperature. If the “available” heating value is used as the value of K , this should be computed on the basis of the superheated steam escaping from the furnace at the temperature of the furnace. It may be obtained more directly from the formula $K = T_1 f c$, T_1 being calculated from the formula given on page 29, viz.:

$$T_1 = \frac{616C + 2220H - 327O - 44 \text{ water}}{f + 0.02 \text{ water} - 0.18H}.$$

Example 2.—Required the efficiency of a boiler using moist wood as fuel, the wood having the composition given on pages 25 and 29, with $K = 6168$ B.T.U., $f = 15$, $T_1 = 1403^\circ$, $a = 200$, $\frac{W}{S} = 3$, $R = 0.081$, $t = 300$.

$$\text{Formula (11), } E_a = \frac{BE_p}{1 + R\frac{S}{W}} - \frac{AW}{SE_p}.$$

$$E_p = 6168 \div 965.7 = 6.387 \text{ U.E.}$$

$$B = \frac{T_1 - t}{T_1} = \frac{1403 - 300}{1403} = 0.786.$$

$$A = \frac{acf}{T_1 - t} = \frac{200 \times 0.24 \times 15}{1103} = 0.653.$$

$$\text{Efficiency} = \frac{E_a}{E_p} = \frac{0.786}{1 + \frac{0.081}{3}} - 0.653 \times \frac{3}{6.39} = 0.765 - 0.307 = 0.458.$$

$E_a = 0.458 \times 6.39 = 2.926$ lb. evaporated from and at 212° per lb. of wood.

$$\begin{aligned} \text{Or, from formula (12), } E_a &= \frac{BE_p}{1 + R\frac{S}{W}} - \frac{AW}{S} \\ &= \frac{0.786 \times 6.39}{1.027} - 0.653 \times 3 = 2.93 \text{ lb.} \end{aligned}$$

This example shows what very low efficiency may be obtained from moist fuels when the air-supply is excessive, even at moderate rates of driving.*

Example 3. Other conditions being the same as above, let $f = 10$ and $T_1 = 2020$.

$$B = \frac{T_1 - t}{T_1} = \frac{1720}{2020} = 0.851.$$

$$A = \frac{acf}{T_1 - t} = \frac{200 \times 0.24 \times 10}{1720} = 0.279.$$

$$\text{Efficiency} = \frac{E_a}{E_p} = \frac{0.851}{1.027} - 0.279 \times \frac{3}{6.39} = 0.698.$$

$$E_a = 0.698 \times 6.39 = 4.46 \text{ lbs. evaporation.}$$

* The air-supply for maximum economy is about 50% in excess of that required to burn the C to CO_2 and the H to H_2O , in order to insure that all the C is burned to CO_2 and none to CO. This corresponds to about 18 lbs. of air per lb. of combustible for anthracite and semi-bituminous coal, but to a much smaller quantity for fuels high in oxygen and moisture, say 9 to 12 lbs. for wood and lignite.

Calculation of the Values of A , B , and a from the Results of Boiler Trials.—From the report of the boiler trials at the Philadelphia Exhibition in 1876 we obtain the following data of the trials of the six boilers showing the highest results reached in the economy trials with anthracite coal, together with the similar data of the capacity trials of the same boilers:

| | Economy Trials. | | | Capacity Trials. | | |
|--------------------|-----------------|---------------|---------------|------------------|---------------|---------------|
| | E_a | $\frac{W}{S}$ | $\frac{S}{W}$ | E_a | $\frac{W}{S}$ | $\frac{S}{W}$ |
| Root..... | 12.094 | 2.586 | .387 | 10.441 | 3.207 | .312 |
| Firmenich..... | 11.988 | 1.932 | .518 | 11.064 | 2.287 | .437 |
| Lowe..... | 11.923 | 2.149 | .466 | 11.163 | 3.171 | .315 |
| Smith..... | 11.906 | 2.785 | .359 | 11.925 | 3.739 | .267 |
| Babcock & Wilcox.. | 11.822 | 2.791 | .358 | 10.330 | 3.840 | .260 |
| Galloway..... | 11.583 | 4.178 | .239 | 11.216 | 5.413 | .185 |

E_a = lbs. of water evaporated from and at 212° per lb. of combustible; W/S = U.E. per sq. ft. of heating surface per hour.

Many desirable data are lacking in the report of these trials, such as analyses of the fuel and of the chimney-gases, the temperature of the fire, the weight of the gases per pound of combustible, which might be calculated from the analyses, and an estimate of the loss by radiation. From the information available, however, reasonable assumptions may be made of the data that are lacking.

The coal was selected anthracite, and its heating value per lb. was probably not far from 14,800 B.T.U. per lb. of combustible. We take then $K = 14,800$, and $E_p = K \div 965.7 = 15.325$.

We may assume that the radiation per lb. of fuel was equal to 3% of E_p when the boilers were driven at the average rate, corresponding to a fuel consumption of 0.231 lb. of combustible per sq. ft. of heating surface. We have then

$$r = 0.03 \times 15.325 = 0.46, \quad \text{and} \quad R = r \frac{F}{S} = 0.106,$$

or, say,

$$R = 0.1$$

From the fact that the economy tests gave very high figures, it is not probable that the weight of gases per lb. of combustible greatly exceeded 20 lbs.; but we shall make two separate assumptions, for the purpose of illustration, viz., that $f = 20$ and 30 lbs., and make the calculations on both assumptions. The temperature of the steam due to the pressure used in the trials was about 316°, and taking the temperature of the atmosphere at 66° this gives $t = 250^\circ$.

Taking c , the specific heat of the gases at 0.24, we have

$$\begin{aligned} \text{for } f &= 20 && 30 \\ cf &= 4.8 && 7.2 \\ tcf &= 1200 && 1800 \\ B = \frac{K - tcf}{K} &= 0.919 && 0.878 \\ BE_p &= 14.08 && 13.46 \\ T_1 = \frac{K}{cf} &= 3083 && 2056 \end{aligned}$$

We cannot find A from the equation $A = \frac{acf}{T_1 - t}$, since a is as yet unknown. We therefore obtain it from eq. (11):

$$E_a = \frac{BE_p}{1 + RS/W} - A \frac{W}{S},$$

which gives $A = \left[\frac{BE_p}{1 + RS/W} - E_a \right] \frac{S}{W}.$

Making the computations, we obtain for the economy trials:

For $f = 20$:

| | Root. | Firm. | Lowe. | Smith. | B. & W. | Gal. |
|--------------------------------|--------|--------|--------|--------|---------|--------|
| $\frac{BE_p}{1 + RS/W} =$ | 13 554 | 13.387 | 13.453 | 13.581 | 13.582 | 13.751 |
| $E_a =$ | 12.094 | 11.988 | 11.923 | 11.906 | 11.822 | 11.583 |
| Difference = | 1.460 | 1.399 | 1.530 | 1.675 | 1.760 | 2.168 |
| Mult. by $\frac{S}{W}$, $A =$ | .565 | .725 | .713 | .601 | .630 | .518 |
| $a = \frac{A(T - t)}{cf} =$ | 333 | 428 | 421 | 355 | 372 | 306 |

And for $f = 30$:

| | | | | | | |
|---------------------------|--------|--------|--------|--------|--------|--------|
| $\frac{BE_p}{1 + RS/W} =$ | 12.963 | 12.800 | 12.868 | 12.989 | 12.989 | 13.150 |
| $A =$ | .336 | .421 | .439 | .389 | .418 | .374 |
| $a =$ | 132 | 165 | 173 | 153 | 164 | 147 |

Using the same values of K , f , and R for the capacity trials, we obtain:

For $f = 20$:

| | Root. | Firm. | Lowe. | Smith. | B. & W. | Gal. |
|-----------------------------|--------|--------|--------|--------|---------|--------|
| $\frac{BE_p}{1 + RS/W} =$ | 13.658 | 13.489 | 13.644 | 13.714 | 13.728 | 13.784 |
| $E_a =$ | 10.441 | 11.064 | 11.163 | 11.925 | 10.330 | 11.216 |
| Difference = | 3.217 | 2.425 | 2.481 | 1.789 | 3.398 | 2.568 |
| Mult. by $\frac{S}{W}, A =$ | 1.004 | 1.060 | .782 | .478 | .883 | .544 |
| $a =$ | 592 | 625 | 461 | 282 | 521 | 321 |

And for $f = 30$:

| | | | | | | |
|---------------------------|--------|--------|--------|--------|--------|--------|
| $\frac{BE_p}{1 + RS/W} =$ | 13.056 | 12.895 | 13.043 | 13.110 | 13.124 | 13.177 |
| $A =$ | .816 | .800 | .572 | .316 | .726 | .416 |
| $a =$ | 321 | 314 | 235 | 124 | 285 | 163 |

The calculated values of a are therefore, for the several cases and for the different assumptions, seen to vary between the wide limits of 124 and 625. The higher figures obtained in the capacity trials with f taken at 20 are improbable, since it is likely that with the stronger draft and the comparatively low economy obtained the air-supply was much greater than that corresponding to a value of $f = 20$.

The results of two tests reported by J. C. Hoadley in *Van Nostrand's Magazine* in 1882 give the data required for computation in more complete form, and leave less room for assumption.

In these tests the following data are given, or may be calculated from the data given:

| | Babcock and Wilcox Boilers. | Return Tubular Boilers. |
|--|-----------------------------|-------------------------|
| Heating value per lb. of combustible..... | $K = 14,344$ | |
| “ “ in evaporation units, $K \div 965.7$ | $E_p =$ | 15 |
| Water evap. from and at 212° per lb. combustible, $E_a =$ | 11.255 | 10.571 |
| Efficiency, $E_a \div E_p$per cent | 75.03 | 70.47 |
| Flue-gases per lb. combustible..... | $f =$ | 30.71 |
| Mean temperature of flue-gases..... | $T_2 + 60 =$ | 467 |
| Loss of efficiency due to heat in the flue-gases, per cent | 20.54 | 25.47 |
| All other losses, including radiation, per cent..... | 4.43 | 3.43 |
| Temperature of fire, calculated by Mr. Hoadley..... | | 1886° F. |
| “ found by pyrometer in hottest part of fire | | 2270° |
| Calculating the elevation of the temperature of the fire above that of the atmosphere (60°) by the formula | | |
| $T_1 = \frac{K}{cf}$ gives..... | 1946° | 1862° |
| Temp. of steam above atmosphere..... | 279° | 279° |
| Calculated value of $B = \frac{T_1 - t}{T_1}$ | .8566 | .8502 |
| $BE_p =$ | 12.849 | 12.753 |

| | | | |
|--|--------------|--------|--------|
| Water evaporated from and at 212° per sq. ft. heating surface..... | $W \div S =$ | 3.99 | 5.27 |
| Taking $R = 0.1$, we have $\frac{BE_p}{1 + RS/W} =$ | | 12.534 | 12.525 |
| Subtract E_a | | 11.255 | 10.571 |
| Gives $A \frac{W}{S} =$ | | 1.279 | 1.954 |
| From which $A =$ | | .321 | .371 |
| $a = A \frac{(T' - t)}{cf} =$ | | 72.6 | 76.3 |

These figures and the ones given above for the value of a indicate that it has a much wider range than that given by Rankine, viz., 160 to 200. The very low figures obtained from Hoadley's tests are, however, probably inaccurate, and the following may be given as a reason to account for them.

A high evaporative result, according to the formula, is consistent with a low value of either f or a . If a high result is obtained, and a high value of f is found from the analysis of the chimney-gases, then the value of a , the unknown quantity, which can be obtained only by computation, using the formula, will appear to be low. The formula, however, is based on the supposition that f is the weight of gas in the furnace per pound of combustible; but the weight of the gas in the chimney may be, and often is, very much greater, on account of leaks of air through the brick setting, between the furnace and the chimney. Hoadley gives the CO_2 in the chimney-gas as ranging from 7.00 to 8.00 per cent by volume; very low figures, probably much lower than that present in the gases just as they left the furnace. If the samples of gas for analysis had been taken from a point near the furnace, instead of from the flue leading to the chimney, higher figures for CO_2 might have been found, which would have made f lower and a higher.

Calculations of values of a obtained from the results of other boiler trials will be given in a later chapter.

General Formulas for Efficiency.—If in eq. (10),

$$E_a = \frac{BE_p}{1 + R \frac{S}{W}} - A \frac{W}{S},$$

we substitute the values of B and A , viz.,

$$B = \frac{K - tcf}{K} \quad \text{and} \quad A = \frac{ac^2f^2}{K - tcf},$$

we obtain

$$E_a = \frac{\frac{K - tcf}{K} E_p}{1 + R \frac{S}{W}} - \frac{ac^2 f^2}{(K - tcf)} \frac{W}{S}, \dots \dots \dots (13)$$

an equation in which, if we consider c , the specific heat of the flue-gases, as a constant, = 0.24, there are no less than six variables, viz., K , t , f , R , W/S , and a . For a given fuel and a given steam-pressure in the boiler K and t may also be taken as constants.

Since $E_p = K \div 966$, we may write

$$E_a = \frac{K - tcf}{966 \left(1 + R \frac{S}{W}\right)} - \frac{ac^2 f^2}{(K - tcf)} \frac{W}{S} \dots \dots \dots (14)$$

Also the efficiency

$$\frac{E_a}{E_p} = \frac{K - tcf}{K \left(1 + R \frac{S}{W}\right)} - \frac{966}{K} \frac{ac^2 f^2}{(K - tcf)} \frac{W}{S} \dots \dots \dots (15)$$

Interpretation of Equation (13).—For a given fuel, completely burned in the furnace, and a given steam-pressure, the evaporation per pound of combustibile will depend—

1. On the heating value of the combustibile, or K .
2. On the elevation of the temperature of the water in the boiler above the atmospheric temperature, or t .
3. On f , the weight of flue-gases per pound of combustibile, which depends on the force of the draft and on the thickness of the bed of fuel and other obstructions to the draft, such as choked air or gas passages, clinker on the grates, etc.
4. On the rate of driving W/S , which depends on the quantity of fuel burned per square foot of heating surface.
5. On the loss by radiation, which may be reduced to a small amount by diminishing the extent of radiating surface and by clothing it with non-conducting material.
6. On the value of the coefficient a , which is not merely a coefficient of the resistance to conduction of heat through the metal plates of the boiler, as it has hitherto been considered in theoretical discussions of the subject, but is also a function of the method in which the gases pass over the heating surface, and of the proportion of the whole heating

surface which is properly covered by the currents of hot gas as they pass from the furnace to the chimney-flue, not being "short-circuited" or covered by eddies of cool gas. If a boiler has its heating surface of moderate thickness, clean inside and out, and the water on one side has a circulation sufficient to sweep away steam or air-bubbles as fast as they form on it, the value of the coefficient a should be low; but if under these favorable conditions the gas-passages have such an arrangement or such proportions as to allow of the short-circuiting of the current of gas or the formation of eddies of cool gas, then the value of a may be high. It should be noted that the coefficient a as here used is not a "constant of nature" whose value is derived from direct experiments on heat transmission, but is only the result of computation of a complex formula (see Eq. 16) which contains six other variables. Any error in the observed data which affects the value of any of these variables will therefore affect the computed value of a .

Large values of f , R , and W/S indicate losses of heat due respectively to excessive supply of air, to excessive radiation, and to excessive rate of driving. A large value of a indicates a loss of heat which may be due to one or more of several causes, such as excessive thickness or defective conducting power of the metal, coatings of scale or grease on one side of the metal, or of soot or dust on the other, short-circuiting of the gases, or imperfect combustion. The multifariousness of this coefficient, therefore, may cause it to have a very wide range of values, say from 100 to 500, instead of the narrow range, 160 to 200, given by Rankine.

The Coefficient a as a Criterion of Boiler Performance.—If we have the following data obtained from the test of a boiler:

K = heating value per lb. of combustible;

W/S = evaporation per sq. ft. of heating surface per hour;

t = temperature of the steam;

E_a = evaporation from and at 212° per lb. combustible,

we may form an approximate estimate of whether or not the performance is high for the given rate of driving by the following method:

From formula (14) we obtain

$$a = \left[\frac{K - tcf}{966 \left(1 + R \frac{S}{W} \right)} - E_a \right] \div \frac{c^2 f^2}{(K - tcf)} \frac{W}{S} \dots \quad (16)$$

For a high evaporation with given values of K , t , and W/S it is necessary that f and R be low, say $f = 20$ and $R = 0.1$. Substitut-

ing these values in the above equation and taking $c = 0.24$, we obtain

$$a = \left[\frac{K - 4.8t}{966 \left(1 + 0.1 \frac{S}{W} \right)} - E_a \right] \div \frac{23.04}{(K - 4.8t)} \frac{W}{S} \cdot \cdot \quad (17)$$

If, on substituting in this equation the observed values of K , t , W/S , and E_a , the value of a comes between 200 and 400, the performance may be considered high; if much above 400, it is from fair to low. The cause of low performance may be low temperature of furnace, due either to imperfect combustion or to excessive air-supply; short-circuiting of the gases, rendering the heating surface ineffective; air-leaks into the setting; moisture in the coal or in the air; unclean heating surface; or excessive radiation.

Applying this formula to the data of the Centennial tests, we will obtain the same values for a as those already given on p. 216 for $f = 20$, $K = 14800$, $t = 250$, ranging from 306 for the Galloway boiler to 428 for the Firmenich in the six economy tests showing the best results.

Applying it to Hoadley's tests, we have:

B. & W. boilers:

$$\left[\frac{14344 - 4.8 \times 279}{966(1 + 0.1 \times 1/3.99)} - 11.255 \right] \div \frac{23.04 \times 5.99}{14344 - 4.8 \times 279} = 308.$$

Tubular boilers:

$$\left[\frac{14344 - 4.8 \times 279}{966(1 + 0.1 \times 1/5.27)} - 10.571 \right] \div \frac{23.04 \times 5.27}{14344 - 4.8 \times 279} = 283.$$

Effect on E_a of Variations of f , R , $\frac{W}{S}$, and a .—We shall now make some computations of different values of E_a , or the evaporation from and at 212° per pound of combustible, based on assumed constant values of K , t , and c , and various values of f , R , a , and W/S . Assume that the coal is anthracite, with a heating value of $K = 14,800$ B.T.U. per lb. combustible; that $t = 300^\circ$, corresponding to steam of 140 lbs. gauge pressure, and atmospheric temperature of 60° ; and c , the specific heat of the flue-gases, $= 0.24$. Then $tc = 72$;

$$E_p = 14,800 \div 966 = 15.321;$$

$$E_a = \frac{14,800 - 72f}{14,800} \times 15.321 - \frac{.0576af^2}{14,800 - 72f} \times \frac{W}{S}.$$

Now assume that $f = 20$ and $a = 200$, and with four different values of R , viz., 0, 0.05, 0.1, and 0.2, calculate the effect of radiation upon the values of the actual evaporation per lb. combustible, E_a , and the efficiency, $E_a \div E_p$, for different rates of driving, $W' \div S$. The results are as below:

Values of E_a and E_a/E_p with $K = 14,800$, $t = 300$, $f = 20$, $a = 200$.

| $W/S =$ | 1 | 2 | 3 | 4 | 6 | 8 |
|------------------------|--------|--------|--------|--------|--------|--------|
| $R = 0, E_a =$ lbs. | 13.485 | 13.140 | 12.795 | 12.450 | 11.761 | 11.071 |
| " $E_a/E_p =$ % | 88.01 | 85.76 | 83.51 | 81.26 | 76.76 | 72.26 |
| $R = 0.05, E_a =$ lbs. | 12.827 | 12.803 | 12.568 | 12.280 | 11.647 | 10.985 |
| " $E_a/E_p =$ % | 83.72 | 83.56 | 82.03 | 80.15 | 76.02 | 71.70 |
| $R = 0.1, E_a =$ lbs. | 12.228 | 12.482 | 12.350 | 12.113 | 11.534 | 10.901 |
| " $E_a/E_p =$ % | 79.81 | 81.47 | 80.61 | 79.06 | 75.28 | 71.15 |
| $R = 0.2, E_a =$ lbs. | 11.180 | 11.883 | 11.930 | 11.782 | 11.315 | 10.734 |
| " $E_a/E_p =$ % | 72.97 | 77.56 | 77.87 | 76.97 | 73.85 | 70.06 |

To determine the effect of various values of f , or the weight of dry chimney-gases per pound of combustible, upon the evaporation and efficiency, take $R = 0.1$, $a = 200$, and $f = 20, 25, 30$, and 35 . The computation gives the results below:

Values of E_a and E_a/E_p with $K = 14,800$, $t = 300$, $R = 0.1$,
 $a = 200$, $f = 20$ to 35 .

| $W/S =$ | 1 | 2 | 3 | 4 | 6 | 8 |
|----------------------|--------|--------|--------|--------|--------|--------|
| $f = 20, E_a =$ lbs. | 12.228 | 12.482 | 12.350 | 12.113 | 11.534 | 10.901 |
| " $E_a/E_p =$ % | 79.81 | 81.47 | 80.61 | 79.06 | 75.28 | 71.15 |
| $f = 25, E_a =$ lbs. | 11.681 | 11.710 | 11.363 | 10.916 | 9.915 | 8.863 |
| " $E_a/E_p =$ % | 76.24 | 76.43 | 74.17 | 71.25 | 64.71 | 57.85 |
| $f = 30, E_a =$ lbs. | 11.076 | 10.823 | 10.203 | 9.486 | 7.950 | 6.362 |
| " $E_a/E_p =$ % | 72.29 | 70.64 | 66.59 | 61.92 | 51.89 | 41.52 |
| $f = 35, E_a =$ lbs. | 10.407 | 9.808 | 8.853 | 7.805 | 5.608 | 3.361 |
| " $E_a/E_p =$ % | 67.93 | 64.02 | 57.78 | 50.54 | 36.60 | 21.94 |

In like manner, we obtain the effect of variations in the value of the coefficient a as follows:

Values of E_a and E_a/E_p with $K = 14,800$, $t = 300$, $R = 0.1$,
 $f = 20$, $a = 100$ to 400 .

| $W/S =$ | 1 | 2 | 3 | 4 | 6 | 8 |
|-----------------------|--------|--------|--------|--------|--------|--------|
| $a = 100, E_a =$ lbs. | 12.401 | 12.827 | 12.867 | 12.805 | 12.568 | 12.279 |
| " $E_a/E_p =$ % | 80.94 | 83.72 | 83.98 | 83.58 | 82.03 | 80.14 |
| $a = 200, E_a =$ lbs. | 12.228 | 12.482 | 12.350 | 12.113 | 11.534 | 10.901 |
| " $E_a/E_p =$ % | 79.81 | 81.47 | 80.61 | 79.06 | 75.28 | 71.15 |
| $a = 300, E_a =$ lbs. | 12.056 | 12.137 | 11.832 | 11.425 | 10.499 | 9.520 |
| " $E_a/E_p =$ % | 78.69 | 79.22 | 77.23 | 74.57 | 68.53 | 62.14 |
| $a = 400, E_a =$ lbs. | 11.883 | 11.792 | 11.316 | 10.734 | 9.464 | 8.141 |
| " $E_a/E_p =$ % | 77.56 | 76.97 | 73.86 | 70.06 | 61.77 | 53.14 |

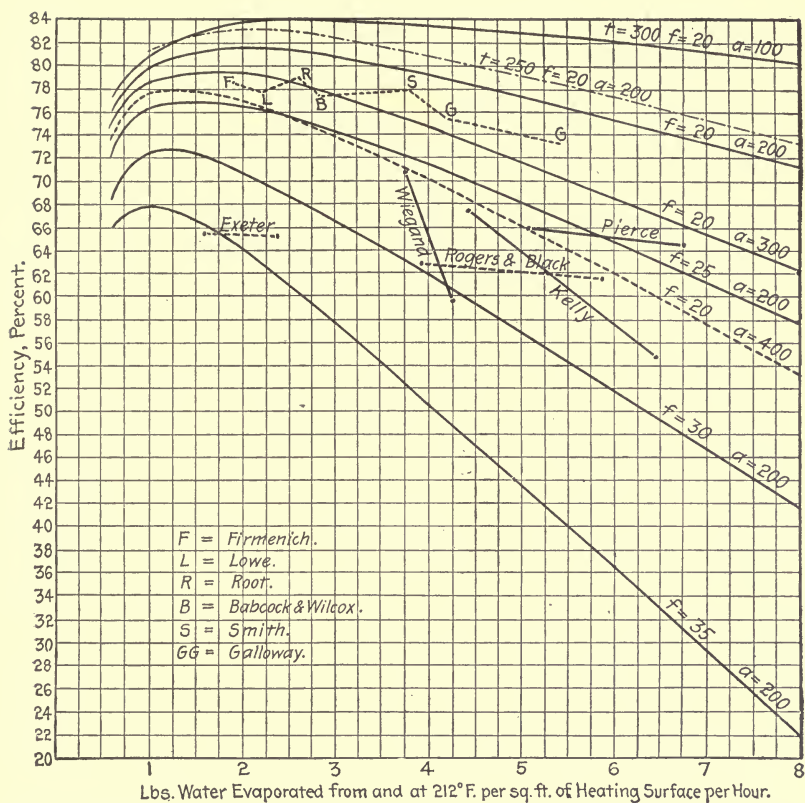

FIG. 49.—CURVES OF CALCULATED EFFICIENCIES FOR DIFFERENT RATES OF DRIVING, for $K = 14,800$, $R = 0.1$, $t = 300$ (except one curve, $t = 250$) $f = 20$ to 35, $a = 100$ to 400.

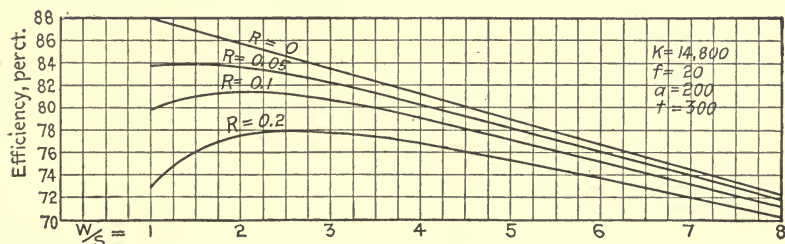

FIG. 50.—EFFECT OF RADIATION UPON EFFICIENCY.

The Effect of Variation in the Steam-pressure, giving different values of t , the elevation of the temperature of the steam above that of the atmosphere, is shown below:

Values of E_a and E_a/E_p with $K = 14,800$, $f = 20$, $R = 0.1$, $a = 200$, and $t = 150^\circ$, 250° , and 300° , corresponding respectively to steam-gauge pressures of 0, 65, and 142 lbs., and atmospheric temperature of 62° F.

| $W/S =$ | 1 | 2 | 3 | 4 | 6 | 8 |
|--------------------------------|--------|--------|--------|--------|--------|--------|
| $t = 150^\circ$, $E_a =$ lbs. | 12.924 | 13.227 | 13.124 | 12.911 | 12.375 | 11.778 |
| “ $E_a/E_p =$ % | 84.35 | 86.33 | 85.66 | 84.27 | 80.76 | 76.87 |
| $t = 250^\circ$, $E_a =$ lbs. | 12.460 | 12.721 | 12.613 | 12.380 | 11.814 | 11.195 |
| “ $E_a/E_p =$ % | 81.33 | 83.03 | 82.32 | 80.80 | 77.11 | 73.07 |
| $t = 300^\circ$, $E_a =$ lbs. | 12.228 | 12.482 | 12.350 | 12.113 | 11.534 | 10.901 |
| “ $E_a/E_p =$ % | 79.81 | 81.47 | 80.61 | 79.06 | 75.28 | 71.15 |

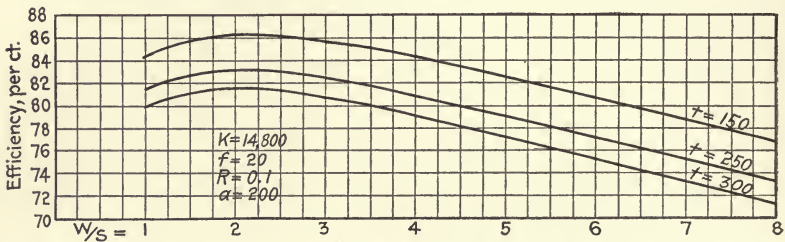

FIG. 51.—EFFECT OF STEAM-PRESSURE UPON EFFICIENCY.

Effect of Heating Value of Fuel on Efficiency.—The value of K , or B.T.U. per lb. combustible, may vary from about 20,000 for petroleum to about 6000 for wood. The formula (13) will not apply without modification to either of these fuels, since another term would have to be subtracted, representing the heat lost in the superheated steam in the chimney-gases, derived from the combustion of the hydrogen in both fuels and from the moisture in the wood. Neglecting this subtractive term and taking two hydrogenous coals, one with a heating value of 16,000 B.T.U. per lb. combustible, about the highest figure for semi-bituminous coal, and the other with 13,600 B.T.U., corresponding to a highly volatile Illinois coal, assuming $f = 20$, $a = 200$, $c = 0.24$, $t = 300$, and substituting these values in equation (13), we obtain the following:

Values of E_a and E_a/E_p corresponding to $K = 13,600$, 14,800, and 16,000, no allowance being made for heat lost in superheated steam in the chimney-gases.

| $W/S =$ | 1 | 2 | 3 | 4 | 6 | 8 |
|-----------------------------|--------|--------|--------|--------|--------|--------|
| $K = 13,600$, $E_a =$ lbs. | 11.065 | 11.231 | 11.045 | 10.765 | 10.108 | 9.402 |
| “ $E_a/E_p =$ % | 78.59 | 79.77 | 78.45 | 76.46 | 71.80 | 66.78 |
| $K = 14,800$, $E_a =$ lbs. | 12.228 | 12.482 | 12.350 | 12.113 | 11.534 | 10.901 |
| “ $E_a/E_p =$ % | 79.81 | 81.47 | 80.61 | 79.06 | 75.28 | 71.15 |
| $K = 16,000$, $E_a =$ lbs. | 13.886 | 13.722 | 13.638 | 13.439 | 12.926 | 12.353 |
| “ $E_a/E_p =$ % | 80.82 | 82.85 | 82.34 | 81.14 | 78.04 | 74.58 |

This table shows that, other conditions being equal, the highest efficiency may be obtained from the fuels of the highest heating value; also that the decrease of efficiency due to rapid rates of driving is greatest

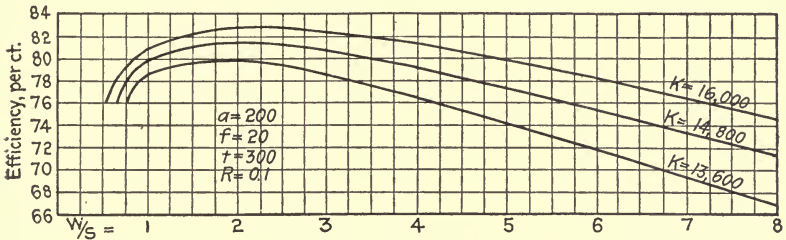

FIG. 52.—EFFECT OF HEATING VALUE OF COAL UPON EFFICIENCY.

with fuels of the lowest heating value. Since for hydrogenous fuels and fuels containing moisture some deduction, amounting usually to upwards of 3%, must be made from the possible efficiency calculated by the formula, on account of loss due to superheated steam in the chimney-gases, it is probable that the highest efficiency will be obtained from anthracite, although the semi-bituminous coals have a higher heating value than anthracite.

This will be shown by the following example:

Required the efficiency obtainable with Pocahontas semi-bituminous coal whose analysis is C, 84.22; H, 4.26; O, 3.48; N, 0.84; S, 0.59; ash, 5.85; moisture, 0.76, the dry chimney-gas being 20 lbs. per lb. of combustible = f ; $a = 200$, $R = 0.1$, $t = 300$. The theoretical elevation of the temperature of the fire, $T_1 = 3110^\circ$, as calculated on p. 30. The heating value, K , calculated from the analysis is 15,850 B.T.U. per pound of combustible.

$$E_p = 15,850 \div 966 = 16.408 \text{ lbs.} \quad T_1 - t = 3110^\circ - 300^\circ = 2810^\circ.$$

We have the formula (12), p. 211, for efficiency,

$$\frac{E_a}{E_p} = \frac{B}{1 + R \frac{S}{W}} - \frac{A W}{S E_p},$$

in which $B = \frac{T_1 - t}{T_1} = \frac{2810}{3110} = 0.9035,$

$$A = \frac{acf}{T_1 - t} = \frac{200 \times 0.24 \times 20}{2810} = 0.3416.$$

We have then for

| | | | | | | |
|---|-------|-------|-------|-------|-------|-------|
| $\frac{W}{S} = \dots\dots\dots$ | 1 | 2 | 3 | 4 | 6 | 8 |
| $E_a \div E_p = \text{per cent.} \dots\dots\dots$ | 80.06 | 81.89 | 81.20 | 79.81 | 76.37 | 72.58 |

The efficiency calculated by formula (13) for $K=16,000$ is, as above,

| | | | | | | |
|------------------|-------|-------|-------|-------|-------|-------|
| Per cent. | 80.82 | 82.85 | 82.34 | 81.14 | 78.04 | 74.58 |
| Difference. | 0.76 | 0.96 | 1.14 | 1.33 | 1.67 | 2.00 |

The efficiency calculated for $K = 14,800$, anthracite, is

| | | | | | | |
|------------------|-------|-------|-------|-------|-------|-------|
| Per cent. | 79.81 | 81.47 | 80.61 | 79.06 | 75.28 | 71.15 |
| Difference. | -0.25 | -0.42 | -0.59 | -0.75 | -1.09 | -1.43 |

Showing that but little higher efficiency can theoretically be obtained from semi-bituminous coal of a heating value of 15,850 B.T.U. per lb. of combustible, even assuming perfect combustion and neglecting the loss due to superheated steam, than from dry anthracite of a heating value of 14,800 B.T.U. With bituminous coals higher in hydrogen, oxygen, and moisture than the semi-bituminous still lower efficiencies are obtainable.

Let us calculate the loss of efficiency due to superheated steam in the chimney-gases.

The coal contains 4.26% H and the combustible 4.59%. This would make $9 \times 4.59 = 41.31$ lbs. of H_2O for each 100 lbs. of combustible. The water in the coal, 0.76%, or 0.82% of the combustible, adds 0.82 lbs. H_2O to the gases, making a total of 42.13 lbs. of superheated steam, or 0.4213 lbs. for each pound of combustible.

Each pound of this steam carries away its latent heat of evaporation at 212° , or 966 B.T.U.; the heat required to superheat it from 212° to the temperature of the escaping chimney-gases; and the heat required to raise 1 lb. of water from the atmospheric temperature to 212° , or say 150° . The temperature of the escaping gases, T_2 ,

may be calculated as follows: Formula (1), $\frac{E_a'}{E_p} = \frac{T_1 - T_2}{T_1}$, gives

$$T_2 = \left(1 - \frac{E_a'}{E_p}\right) T_1. \text{ But } E_a' \text{ is the evaporation including loss by}$$

radiation, or $E_a + r = E_a \left(1 + R \frac{S}{W}\right)$, whence

$$T_2 = \left(1 - \frac{E_a}{E_p} \left(1 + R \frac{S}{W}\right)\right) T_1.$$

This gives for $W/S = 1$, $T_2 = 370^\circ$, and for $W/S = 8$, $T_2 = 824^\circ$. The loss of heat due to the superheated steam then is:

for $W/S = 1$, $0.4213 (150 + 966 + 0.48 \times 370) = 545$ B.T.U. ;

for $W/S = 8$, $0.4213 (150 + 966 + 0.48 \times 824) = 637$ B.T.U.

The first result is 3.44%, and the second 4.02% of the heating value, 15,850 B.T.U. per pound combustible, reducing the efficiency calculated by the formula from 80.06 to 76.62, for $W/S = 1$, and from 72.58 to 68.56 for $W/S = 8$. The efficiencies thus reduced are respectively 3.19% and 2.59% below the corresponding efficiencies for anthracite.

The values of efficiency given in the tables on pages 222 and 224 are plotted on the diagrams accompanying them. In Fig. 49 there are also plotted the values of the highest results obtained at different rates of evaporation in the Centennial tests, and, for comparison, some of the lowest results at different rates of evaporation in the same tests.

A study of the diagrams leads to several important conclusions:

1. The results of seven Centennial tests, *F*, *L*, *R*, *B*, *S*, and *GG*, which are the highest reliable results ever obtained with anthracite coal for the rates of evaporation shown, lie a little below the curve of $R = 0.1$, $f = 20$, $a = 200$.

2. The curve of $R = 0.1$, $f = 20$, and $a = 100$ lies so much above the curve of these Centennial tests as to make the value $a = 100$ highly improbable, although the two tests by Hoadley above referred to give $a = 72.6$ and 76.3 for $f = 30.71$ and 32.10 . There is no apparent reason why a should be low when f is high, and a possible explanation of the very low values of a calculated from Hoadley's results has already been given.

3. The effect of radiation on the evaporation is comparatively small for values of R between 0.05 and 0.2 (which is probably as high a range as is found in practice when the boilers are well covered) when the rate of evaporation is over 3 lbs. per square foot of heating surface per hour, but it increases rapidly at low rates of evaporation.

4. The effect of variations of a within the limits of $a = 100$ and $a = 300$ increases rapidly with the increase of rate of evaporation; but the effect of increase of a is not nearly so important as the effect of increase of f .

5. The effect of increase of f , which is a measure of the air-supply per pound of combustible, is of extreme importance, especially at high rates of driving. With $R = 0.1$ and $a = 200$ the effect on E_a of increase of f with different values of W/S is shown in the following figures:

| | $f = 20$ | $f = 30$ | $f = 35$ |
|----------------------------------|----------|----------|----------|
| $W/S = 2, E_a = \dots\dots\dots$ | 12.48 | 10.83 | 9.81 |
| “ = 4, “ = $\dots\dots\dots$ | 12.11 | 9.49 | 7.81 |
| “ = 6, “ = $\dots\dots\dots$ | 11.53 | 7.95 | 5.61 |

A value of $f = 20$, corresponding to 19 lbs. of air supplied per pound of combustible, is about as low as can be obtained in practice without incomplete combustion of a part of the fuel, resulting in some CO in the furnace-gases. The rapid decrease in economy as the air-supply is increased shows how important it is to so regulate the thickness of the bed of coal, as related to the force of draft, as to keep the supply of air at or near 19 lbs. per lb. of combustible.

Value of c .—In all the above calculations we have taken c , the specific heat of the flue-gases, as constant, = 0.24. The actual specific heat of a mixed gas is found by multiplying the percentage by weight of each constituent by its specific heat, adding the products and dividing by 100. The specific heats of the constituents of flue-gases are: O, 0.2175; N, 0.2438; CO, 0.2479; CO₂, 0.217. The calculated specific heat of flue-gases usually ranges between 0.235 and 0.24. If 0.235 were used instead of 0.24 in computations of eq. (13), the results would be higher by about half of one per cent. It is probable, however, that the figures for the specific heat of the constituent gases given above, which are those given in most text-books as the specific heats of gases at ordinary atmospheric temperatures, are somewhat too low for hot gases. The figure 0.24 is therefore as accurate a one as can be had with our present knowledge, but the average figure, 0.237, calculated from ordinary compositions of furnace-gas is frequently used.

Practical Conclusions derived from the above Theoretical Discussion.—Many important deductions may be made from a study of the figures derived from equation (13) and of the diagrams plotted therefrom. It may be well first to restate the notation of that formula:

E_a = lbs. water actually evaporated from and at 212° (or U.E.) per lb. of combustible;

E_p = theoretically possible evaporation in U.E. per lb. of combustible, = $K \div 965.7$;

E_a/E_p = efficiency, usually expressed as a percentage;

K = heating value of the fuel, in B.T.U. per lb. combustible;

t = temperature of the water in the boiler, minus the temperature of the air-supply;

c = specific heat of the gases, taken as a constant = 0.24;

f = lbs. of gas per lb. of combustible;

R = radiation, in U.E. per sq. ft. of heating surface per hour;
 W/S = rate of driving, U.E. per hour per sq. ft. of heating surface;
 a = an experimental coefficient expressing the resistance of the plates and tubes of the boiler to the transmission of heat, together with certain losses of efficiency due to short-circuiting of the gases, to eddies of cool gas, etc.

The formula is

$$E_a = \frac{\frac{K - tef}{K} E_p}{1 + R \frac{S}{W}} - \frac{ac^2f^2}{(K - tef)} \frac{W}{S}$$

The first deduction from the study already made is that the efficiency of a boiler is an exceedingly variable quantity, depending on no less than six variable factors, K , t , f , R , W/S , and a . Only one of these factors, viz. a , is related to the construction of the boiler and to the condition of its heating surface, and this only partly, for to some extent it depends on the rate of driving, since short-circuiting of the currents of hot gas may be influenced by the rate of driving. The value of R depends upon the effectiveness of the protection of the boiler and furnace from loss by radiation. All of the other factors are functions of the conditions under which the boiler is operated.

The importance of the factor a upon the efficiency, as shown in the diagram Fig. 49, leads to the conclusion that, so far as possible, the metal of the heating surfaces should be thin; they should be kept clean inside and out; the gas-passages should be so constructed that the currents of hot gas will pass uniformly over the whole extent of heating surface, avoiding short-circuiting and eddies, or the passage at greater speed over some portions than over others; the circulation of water should be sufficient to wipe off bubbles of air or steam as fast as formed; and the combustion should be complete.

The effect of K on the efficiency, as shown in Fig. 52, indicates that the heating value of a fuel is not exactly a measure of its practical value. For a rate of driving $W/S = 3$ we have found, with $f = 20$ and $a = 200$:

| | | | |
|--|--------|--------|--------|
| For $K =$ | 13,600 | 14,800 | 16,000 |
| $E_a/E_p =$ per cent | 78.45 | 80.61 | 82.34 |
| $K \times E_a/E_p =$ | 10,669 | 11,930 | 13,174 |
| While the heating values are in the ratio..... | 91.9 | 100 | 108.1 |
| The practical values are in the ratio..... | 89.5 | 100 | 110.4 |

If coal of 14,800 B.T.U. per lb. is worth \$1 per ton, coal of 13,600 B.T.U. is worth, not 91.9 cents, but 89.5 cents, if the rate of driving

of the boiler is 3 lbs. per sq. ft. of heating surface per hour, and still less if the rate is greater.*

The effect of the rate of driving, W/S , shown in the diagrams, indicates that for practically all values of the other variables the evaporation and the efficiency are a maximum when the rate of driving is about 2 lbs. evaporation per sq. ft. of heating surface per hour; but that under fairly good conditions, as when $f = 20$, $a = 200$, the efficiency is but slightly less at 3 lbs. If 3000 lbs. of water per hour are to be evaporated, a boiler of 1000 sq. ft. of heating surface will be almost as economical of fuel as one of 1500 sq. ft., provided the boiler is well constructed, so that a may be 200 or less, the coal is of good quality, say $K = 14,800$, and the management of the fire and draft good, so that $f =$ about 20; but if these conditions are unfavorable, then the boiler of 1500 sq. ft. may be much more economical than one of 1000 sq. ft. When good operating conditions are obtainable the small saving in fuel by the larger boiler will probably be more than offset by its greater cost, so that practically boilers proportioned for a rate of driving of 3 lbs. per sq. ft. of heating surface per hour will give about the maximum economy of all costs, including interest on investment, depreciation, etc. When fuel is of very low cost, as near a coal-mine, or when a boiler is to be run at full capacity only a few hours per day, as in electric-lighting plants, boilers proportioned for a much higher rate of driving may be the most economical in total cost.

The effect of R on evaporation is seen to be very slight at all rates of driving above 2 lbs., but it increases rapidly at lower rates. When the rate is below $1\frac{1}{2}$ lbs., and there are two boilers in a plant, it will usually pay to shut down one of them, driving the other at a 3-lb. rate, thereby saving half of the loss due to radiation.

The effect of high values of f , or excessive air-supply, is seen to be more important than that of any other of the variable factors in the equation. It is therefore of the utmost importance to so regulate the draft and the firing that the air-supply shall be no more than sufficient to maintain complete combustion. A very high furnace temperature is the invariable indication of the best furnace conditions, and every effort should be made to secure and maintain this high temperature.

* The calculation is based on $f = 20$ in each case. The coal of $K = 13,600$ would be high in oxygen and water, and with it f might be less than 20 without causing CO in the gases. A lower value of f would cause the efficiency to be higher than the figure given in the table.

The effect of the temperature of the water in the boiler upon the efficiency is not important within the limits of ordinary steam-boiler practice; but a gain of about 8 per cent in the evaporation, when the rate of driving is about 3 lbs. per sq. ft. of heating surface per hour, might be effected if it were possible to have the water in the boiler of a temperature as low as 212° F. Boiler-tests have sometimes been made with the water evaporated at atmospheric pressure. Records of efficiency obtained in such tests are not a fair measure of the efficiency which would be obtained at customary steam-pressures. The Centennial tests were made with steam of 70 lbs. gauge pressure, corresponding to $t =$ about 250° . If they had been made with steam of 140 lbs., the evaporation per lb. of combustible would probably have been 0.25 lb. less in those tests which gave the highest results, reducing their record of about 12 lbs. from and at 212° per lb. combustible to about 11.75 lbs.

Results corresponding to $f = 20$ and $a = 200$, and an efficiency of 80 per cent are scarcely possible. The highest results obtained in the Centennial tests are shown on the plotted diagram, and no higher results with anthracite have ever been obtained in competitive tests made by disinterested experts since 1876: all fall below 80% efficiency, and considerably below the plotted line of $f = 20$, $a = 200$, and $t = 250^{\circ}$. It is possible to obtain a value of a as low as 200 in a boiler so designed and proportioned as to avoid all short-circuiting of the gases, and it is also possible to obtain nearly perfect combustion with f as low as 20 lbs. per lb. of combustible, but it is difficult to have both f and a at these low values at the same time. Boilers must be designed with flues or other gas-passages of ample area to insure against choking of the draft, and to allow of the boiler being driven beyond its normal rating, but large gas-passages are apt to lead to more or less short-circuiting, hence to inefficiency of some portions of the heating surface, corresponding to high values of a . The line on the diagram $f = 20$, $a = 200$, must therefore be considered as one which may sometimes, under the most favorable conditions, be nearly but never quite reached, and an efficiency of 80 per cent as a little beyond the best result that may be reached in practice. With semi-bituminous and bituminous coal there is a necessary loss of efficiency due to the hydrogen in the coal, and the consequent loss of heat in superheated steam in the chimney-gases. This loss is rarely less than 3%. We may therefore conclude that about 79% is the highest efficiency that can be reached in practice with anthracite coal and 76% with bituminous or semi-bituminous.

Much higher figures than these are sometimes published, but they are due either to errors in the boiler-test or to too low figures for the heating value of the coal.

The theoretical values of efficiency given in the foregoing tables and plotted on the diagrams are all based on the supposition that the combustion is perfect and that the air-supply and the furnace temperature are constant. It is impossible to realize these conditions with hand-firing, since the opening of the fire-door and the firing of fresh coal always chill the furnace. The fresh coal, if small in size, checks the air-supply to some extent and tends to make the combustion imperfect for a short time after it is fired. After the fresh coal has been partly burned away the air-supply is apt to be excessive. All these causes tend to make the efficiency less than that given by the theoretical calculation. With automatic stokers, however, it is possible to obtain greater uniformity of conditions, and consequently a closer approximation to the theoretical efficiencies.

Low Temperature of Furnace may cause High Flue Temperature.

—With high rates of driving and excessive supply of air per pound of fuel a large proportion of the heating value of the fuel is used in heating air which is carried into the chimney instead of in generating steam. Excessive air-supply causes not only a low temperature of the furnace, but it may also cause a high temperature of the chimney-gases, as is shown by the following calculation: Take from the above tables the case of $K = 14,800$, $c = 0.24$, $t = 300$, $a = 200$, and $W/S = 6$, with four different values of f , viz.,

| | | | | |
|---|--------|-------|-------|-------|
| $f =$ | 20 | 25 | 30 | 35 |
| $E_a =$ lbs | 11.534 | 9.915 | 7.950 | 5.608 |
| Efficiency, $E_a/E_p =$ per cent | 75.28 | 64.71 | 51.89 | 36.60 |
| Elev. of temp. of fire, $T_1 = K \div cf =$ | 3083° | 2467° | 2056° | 1762 |

We have $\frac{E_a'}{E_p} = \frac{T_1 - T_2}{T_1}$, whence flue temperature $T_2 = T_1 \left(1 - \frac{E_a'}{E_p}\right)$,

but E_a' is what the evaporation would be if there were no radiation. It differs from E_a , the actual evaporation, by the quantity

$$E_a' - E_a = BE_p - \frac{BE_p}{1 + \frac{RS}{W}} - A \frac{W' - W}{S} = \frac{BE_p}{1 + \frac{RS}{W}} - AR.$$

We have, therefore,

| | | | | |
|-----------------------------------|--------|--------|-------|-------|
| $E_a' - E_p =$ | 0.192 | 0.175 | 0.133 | 0.094 |
| $E_a' =$ | 11.726 | 10.090 | 8.083 | 5.702 |
| $E_a' \div E_p =$ per cent | 76.54 | 65.27 | 52.76 | 37.22 |
| $T_2 = T_1(1 - E_a'/E_p) =$ | 723° | 857° | 971° | 1105° |

The calculation assumes that there are no air-leaks through the setting between the furnace and chimney which would lower the temperature of the chimney-gases and decrease the efficiency.

At low rates of driving, excessive air-supply does not cause so great a rise in the flue temperature; thus for $W/S = 2$, and other conditions as above, we have:

| | | | | | | |
|-----------------|---|---------------|--------|--------|--------|--------|
| for f | = | | 20 | 25 | 30 | 35 |
| E_a | = | | 12.482 | 11.710 | 10.823 | 9.808 |
| $E_a \div E_p$ | = | per cent..... | 81.47 | 76.43 | 70.64 | 64.02 |
| T_1 | = | | 3083° | 2467° | 2056° | 1762° |
| $E_a' - E_p$ | = | | 0.590 | 0.530 | 0.459 | 0.376 |
| E_a' | = | | 13.072 | 12.240 | 11.282 | 10.184 |
| $E_a' \div E_p$ | = | per cent..... | 85.32 | 79.89 | 73.64 | 66.47 |
| T_2 | = | | 453° | 496° | 542° | 591° |

Relation of Furnace Temperature to Extent of Heating Surface

required for good Economy.—From the formulæ $E_a' = BE_p - A \frac{W'}{S}$,

$B = \frac{T_1 - t}{T_1}$, and $A = \frac{acf}{T_1 - t}$, it is evident that the actual evaporation

per pound of fuel, for a given rate of driving W'/S , depends on the furnace temperature T . This temperature depends not only on the quantity of air supplied per pound of fuel, but also on the thoroughness of the combustion effected by it, as well as on the dryness of the coal and air and on the amount of direct radiation. An air-supply of 19 lbs. per lb. of carbon, making nearly 20 lbs. of gas, will usually produce the maximum temperature, a lesser supply tending to make the combustion imperfect, and a greater causing excessive dilution of the gases, both of which diminish the temperature. With the proper supply of air, however, combustion may still be imperfect and the temperature low, on account of imperfect mixing of the air with the gas distilled from the coal, irregular firing, too small space for combustion in the furnace, or other causes.

1. Consider a case in which combustion is perfect, with $E_p = 15$, $T_1 = 3000^\circ$, $t = 300$, $a = 200$, $c = 0.24$, $f = 20$, $W'/S = 3$, and radiation negligible.

$$B = \frac{T_1 - t}{T_1} = \frac{3000 - 300}{3000} = 0.9;$$

$$A = \frac{acf}{T_1 - t} = \frac{200 \times 0.24 \times 20}{2700} = 0.356;$$

$$E_a' = BE_p - A \frac{W'}{S} = 0.9 \times 15 - 0.356 \times 3 = 12.432.$$

2. With other conditions the same as above let $T_1 = 2000^\circ$, being reduced by imperfect combustion. Then

$$B = \frac{2000 - 300}{2000} = 0.85; \quad A = \frac{960}{1700} = 0.565;$$

$$E_a' = 0.85 \times 15 - 0.565 \times 3 = 11.055.$$

3. Find the value of W'/S which with $T_1 = 2000^\circ$ will give an evaporation of 12.432.

$$E_a' = BE_p - A \frac{W'}{S}; \quad 12.432 = 0.85 \times 15 - 0.565 \frac{W'}{S};$$

whence $W'/S = 0.320 - 0.565 = 0.566$.

This means that in order to obtain the same capacity and the same economy combined from a boiler with a furnace temperature of 2000° as can be obtained with 3000° , under the conditions named, it would be necessary to increase the heating surface in the ratio of 3 to 0.566, or over five times. The case is still worse if radiation is taken into account, for the loss by radiation per pound of fuel burned is much greater at very low than at moderate rates of driving. Let r = loss by radiation, in units of evaporation per pound of fuel, then $E_a' - r = BE_p - A \frac{W'}{S}$. If r in the last case = 0.32, then $E_a' = 12.43 + 32 = 12.75 - 0.565 \frac{W'}{S}$, whence $W'/S = 0$; that is, the evaporation (including radiation) of 12.43 U.E. per lb. fuel could not be reached by any enlargement of heating surface whatever if the furnace temperature were as low as 2000° .

4. Suppose the furnace temperature is reduced not by imperfect combustion but by excessive air-supply. Let $f = 30$ lbs. and $T = 2000^\circ$.

$$B = 0.85 \text{ as before; } A = \frac{acf}{T_1 - t} = \frac{200 \times 24 \times 30}{1700} = 0.847;$$

$$E_a = 0.85 \times 15 - 0.847 \times 3 = 10.21 \text{ for } W'/S = 3.$$

5. With $f = 30$, required W'/S to make $E_p = 12.43$.

$$12.43 = 0.85 \times 15 - 0.847 W'/S;$$

$$W'/S = (12.75 - 12.43) \div 0.847 = 0.37,$$

a figure which would probably be reduced to 0 by radiation.

Examples 3 and 5 show that high furnace temperature is even a more important factor of economy than extent of heating surface.

A. Blechynden's Experiments on Transmission of Heat through plates from hot gases on one side, to water on the other.* In these experiments the water was contained in a cylindrical iron vessel of tinned iron plate, 24 W. G. in thickness, with the steel plate to be tested soldered in the bottom. The vessel, protected from radiation by air-spaces and asbestos felt, was placed above a fire-brick furnace, the lower half of which was filled with asbestos lumps or balls, covered with wire gauze. Jets of gas were burned among these balls, generating a high temperature in the products of combustion in the upper part of the furnace. The hot gases were allowed to escape through four small horizontal pipes at the top of the furnace, on four sides, so that the plate was exposed on its bottom surface to hot gas at a practically uniform temperature.

Experiments were made on five plates of different thicknesses, viz., plate A, originally 1.1875 in. thick, and reduced in four successive operations, by machining, to 0.125 in. thick; plate B, four thicknesses, from 0.4688 in. thick to 0.1562 in. thick; plate C, 0.8125 in.; plate D, 0.5 in.; plate E, 1.1875 in., and 0.1875 in. Plates A, B and D had one side machined, and the other side (that exposed to the fire) left with the natural surface, as it came from the mill. Plate C had both sides untouched, and plate E both sides machined.

The temperature of the furnace was determined by a Siemens copper-ball pyrometer. In some cases an iron ball was used instead. The specific heats of both were compared with that of a piece of platinum, and the temperatures recorded depend upon Pouillet's determination of the specific heat of platinum, as in the following table:

| Temp. C. | Temp. F. | Platinum, Sp. Ht. (Pouillet). | Iron, Sp. Ht. | Copper, Sp. Ht. |
|-------------------|------------|----------------------------------|------------------|--------------------|
| Between 0 and 100 | 32 and 212 | 0.0335 | 0.1095 | 0.0961 |
| " 0 " 300 | 32 " 572 | .0343 | .1189 | .0997 |
| " 0 " 500 | 32 " 932 | .0352 | .1279 | .1032 |
| " 0 " 700 | 32 " 1292 | .0360 | .1374 | .1068 |
| " 0 " 1000 | 32 " 1832 | .0373 | | melts. |
| " 0 " 1200 | 32 " 2192 | .0382 | | |

The following results were obtained in the experiments: $T - t$ being the difference between the temperature F , of the gas below the plate and the water above it, q , the quantity of heat transmitted in British thermal units per hour per square foot, and a , coefficient of transmission calculated from the formula

* Trans. Inst. Naval Architects, 1894; Also Donkin's "Heat Efficiency of Steam-boilers," p. 145.

$$q = \frac{(T-t)^2}{a}, \text{ or } a = \frac{(T-t)^2}{q}$$

PLATE A, 1.1875 IN. THICK.

| | | | | | | |
|---------------|--------|--------|--------|--------|--------|--------|
| $T-t =$ | 848 | 993 | 1,013 | 1,213 | 1,228 | 1,278 |
| $q =$ | 10,800 | 14,760 | 15,480 | 22,740 | 24,480 | 26,760 |
| $a =$ | 66.6 | 66.8 | 66.3 | 64.7 | 61.6 | 61.0 |

PLATE A, 0.75 IN. THICK.

| | | | | | | |
|---------------|-------|--------|--------|--------|--------|--|
| $T-t =$ | 626 | 788 | 913 | 1,053 | 1,233 | |
| $q =$ | 6,840 | 10,920 | 14,640 | 20,280 | 27,120 | |
| $a =$ | 57.2 | 56.9 | 56.9 | 55.2 | 56.1 | |

PLATE A, 0.562 IN. THICK.

| | | | | | | |
|---------------|-------|--------|--------|--------|--|--|
| $T-t =$ | 563 | 708 | 963 | 1,148 | | |
| $q =$ | 6,720 | 10,200 | 19,440 | 29,520 | | |
| $a =$ | 47.2 | 49.1 | 47.7 | 44.6 | | |

PLATE A, 0.25 IN. THICK.

| | | | | | | |
|---------------|-------|-------|--------|--------|--------|--------|
| $T-t =$ | 503 | 646 | 723 | 828 | 893 | 978 |
| $q =$ | 5,940 | 9,240 | 11,880 | 15,420 | 18,480 | 22,620 |
| $a =$ | 42.6 | 45.2 | 44.0 | 44.5 | 44.2 | 42.3 |

PLATE A, 0.125 IN. THICK.

| | | | | | | | | |
|---------|--------|--------|--------|--------|--------|--------|--------|--------|
| $T-t =$ | 738 | 908 | 993 | 1,083 | 1,123 | 1,133 | 1,138 | 1,318 |
| $q =$ | 12,180 | 18,840 | 24,000 | 27,600 | 30,600 | 30,900 | 31,320 | 45,120 |
| $a =$ | 44.7 | 43.7 | 41.1 | 42.5 | 41.2 | 41.5 | 41.3 | 38.5 |

PLATE B, 0.4687 IN. THICK.

| | | | | | | | | |
|---------|-------|-------|-------|--------|--------|--------|--------|--------|
| $T-t =$ | 413 | 638 | 643 | 993 | 1,028 | 1,123 | 1,128 | 1,148 |
| $q =$ | 4,260 | 9,180 | 9,360 | 23,520 | 25,500 | 30,420 | 30,840 | 31,920 |
| $a =$ | 39.8 | 44.3 | 44.2 | 41.9 | 41.4 | 41.1 | 41.2 | 41.3 |

PLATE B, 0.375 IN. THICK.

| | | | | | | | |
|---------|-------|--------|--------|--------|--------|--------|--------|
| $T-t =$ | 650 | 656 | 958 | 968 | 1,108 | 1,288 | 1,308 |
| $q =$ | 9,540 | 10,380 | 22,740 | 22,860 | 30,420 | 41,460 | 43,140 |
| $a =$ | 44.3 | 41.4 | 40.9 | 42.3 | 41.0 | 40.0 | 39.7 |

PLATE B, 0.25 IN. THICK.

| | | | | | | | | | |
|---------|-------|-------|--------|--------|--------|--------|--------|--------|--------|
| $T-t =$ | 373 | 513 | 773 | 823 | 848 | 855 | 1,108 | 1,128 | 1,268 |
| $q =$ | 3,595 | 6,560 | 14,700 | 17,220 | 18,310 | 19,020 | 31,380 | 33,150 | 43,800 |
| $a =$ | 38.7 | 40.1 | 40.7 | 39.3 | 39.3 | 38.4 | 39.1 | 38.4 | 36.7 |

PLATE B, 0.156 IN. THICK.

| | | | | | | | |
|---------|-------|--------|--------|--------|--------|--------|--------|
| $T-t =$ | 543 | 738 | 973 | 1,058 | 1,123 | 1,248 | 1,263 |
| $q =$ | 7,560 | 13,560 | 24,660 | 28,920 | 32,880 | 43,880 | 42,420 |
| $a =$ | 39.0 | 40.2 | 38.4 | 38.7 | 38.3 | 38.2 | 37.4 |

PLATE C, 0.8125 IN. THICK.

| | | | | | | |
|-----------|-------|--------|--------|--------|--------|--------|
| $T - t =$ | 652 | 763 | 773 | 778 | 778 | 848 |
| $q =$ | 7,740 | 10,860 | 11,400 | 10,440 | 11,160 | 12,480 |
| $a =$ | 54.9 | 53.6 | 52.4 | 58.0 | 54.2 | 57.6 |

PLATE D, 0.5 IN. THICK.

| | | | | | | | | |
|-----------|-------|--------|--------|--------|--------|--------|--------|--------|
| $T - t =$ | 439 | 755 | 738 | 744 | 768 | 847 | 879 | 910 |
| $q =$ | 4,260 | 13,200 | 13,080 | 13,560 | 13,980 | 16,200 | 18,720 | 20,400 |
| $a =$ | 45.2 | 43.2 | 41.6 | 40.8 | 42.2 | 44.3 | 41.3 | 40.6 |

PLATE E, 1.1875 IN. THICK.

| | | | | |
|-----------|-------|-------|-------|--------|
| $T - t =$ | 301 | 440 | 644 | 1,073 |
| $q =$ | 1,440 | 2,760 | 5,220 | 16,140 |
| $a =$ | 62.9 | 70.0 | 79.4 | 71.3 |

PLATE E, 0.1875 IN. THICK.

| | | | | |
|-----------|-------|-------|--------|--------|
| $T - t =$ | 322 | 559 | 743 | 1,128 |
| $q =$ | 1,980 | 6,000 | 10,320 | 24,900 |
| $a =$ | 52.4 | 52.1 | 53.5 | 51.1 |

AVERAGE VALUES OF THE COEFFICIENT a .

| | | | | | |
|--------------------|------------|----------|------------|----------|-----------|
| Plate A, Thickness | 1.1875 in. | 0.75 in. | 0.5625 in. | 0.25 in. | 0.125 in. |
| $a =$ | 64.5 | 56.5 | 47.1 | 43.8 | 41.9 |
| Plate B, Thickness | 0.4687 | 0.375 | 0.25 | 0.156 | |
| $a =$ | 41.9 | 41.4 | 39.0 | 38.6 | |
| Plate C, Thickness | 0.8125 | | | | |
| $a =$ | 55.1 | | | | |
| Plate D, Thickness | 0.5 | | | | |
| $a =$ | 42.4 | | | | |
| Plate E, Thickness | 1.1875 | 0.1875 | | | |
| $a =$ | 71.9 | 52.3 | | | |

Mr. Blechynden says: "The broad general fact is evident that the heat transmitted through any of the plates per degree of difference of temperature of the water and the fire is proportional to that difference; or in other words, the heat transmitted is proportional to the square of the difference between the temperature at the two sides of the plate, or

$$\frac{\text{Heat transmitted per sq. ft.}}{(\text{Difference of temperature})^2} = \text{a constant}$$

for each plate within the limits of the experiments."

Mr. Blechynden gives this constant, or modulus, for each plate. It is the reciprocal of the coefficient a , which has been calculated by the author from the average results, for the purpose of comparing it with the similar coefficient used by Rankine and others, and adopted in the preceding discussion on the efficiency of heating surface.



Mr. Blechynden further says: "The table shows that there is a general rise in the value of the moduli [a decrease of a] with decrease of thickness, but there are considerable irregularities in the curves joining the various points for each plate. This is perhaps no more than might be expected, because of the great difficulty of machining all the surfaces to the same degree of smoothness, and notwithstanding the precautions taken, the difficulty of maintaining the surfaces uniformly clean. It was found that the very slightest traces of grease caused a very large fall in the rate of transmission; even wiping the surface of the plate with a piece of rag or waste was sufficient to influence the result detrimentally. That the smoothness of the surfaces was an important factor will be readily seen when the position of the points for the plate E are compared with the others. The differences are due to A and B having the receiving surface as from the mill, while E was very smoothly machined.

"The results of these experiments certainly point to the conclusion that the thinner the plates forming part of the heating surface of a

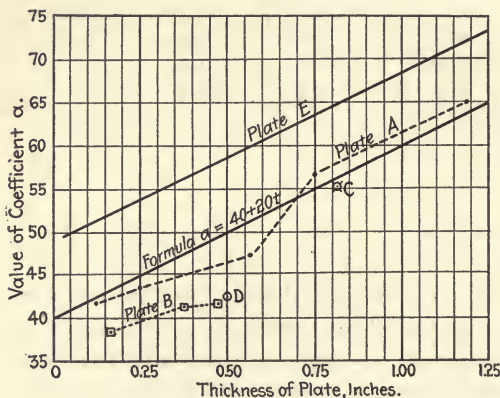

FIG. 53.—VALUES OF α , FROM BLECHYNDEN'S EXPERIMENTS.

boiler the higher should be the boiler efficiency, always provided that the plates are clean, but it will be evident that if the plates be coated with a covering of scale, or some bad conductor, then the less must be the influence of the thickness on the efficiency, while with a thick coat of oil the influence might become practically unimportant. The fact that the heat transmission is proportional to the square of the difference of temperature of the two sides of the plate shows the importance of high furnace temperatures."

The average values of the coefficient α obtained from Blechynden's experiments have been plotted in the adjoining diagram, Fig. 53. It will be seen that each plate has a law of rate of transmission of its own. Plates A and C have about the average values for the different thick-

nesses, and a line plotted from the formula $a = 40 + 20 t$ is near to all the values obtained from plate A. The formula $a = 40 + 20 t \pm 10$ covers the whole range of the experiments.

The very low values of a deduced from Blechynden's experiments, viz., 38.6 to 71.9, as compared with the values 200 to 400, commonly obtained in steam-boiler tests, are no doubt due to the exceptionally favorable conditions under which his experiments were made, all portions of the plate being clean and equally exposed to radiation and to contact with the hot gases, while in steam-boilers only a small fraction of the heating surface receives radiation from the incandescent fuel or from glowing fire-brick, the surface is apt to be more or less covered with soot, dust, scale, or grease, and the whole heating surface is not equally effective, part of it being short-circuited and in contact with eddies of comparatively cool gas.

Durston's Experiments on the Transmission of Heat through Plates.*—A. J. Durston describes some experiments made to determine the temperature of the hot side of a plate, exposed to hot gases, when the other side was covered with boiling water. The temperature was determined by the melting of fusible solders on the hot side of the plate. The following is a summary of the results:

1. Temperature of hot side of a clean plate exposed to gases at about 1500° F about 240° F.
2. Same with a layer of grease $\frac{1}{8}$ in. thick over inside of vessel... " 330°
3. Temperature at the centre of thickness of a plate.... between 290° and 336°
4. Loss of efficiency of heating surface of boiler-tubes due to a thin coating of grease, 8 to 15 per cent; mean of several experiments, 11%.
5. Temperature of hot side of plates where boiling water in an open vessel under various conditions; a flanged dish 2 ft. diameter, $2\frac{1}{2}$ in. deep, $\frac{1}{4}$ in. thick :

| | Temperature of Fire. | Temp. Hot Side of Plate. |
|---|-------------------------|-----------------------------|
| Clean fresh water..... | 2200° | 280° |
| Mineral oil gradually added up to 5%..... | 2300° | 310° |
| Fresh water with 2½% of paraffine..... | 2100° | 330° |
| Fresh water with 2½% of methylated spirits... | 2500° | 300° |
| A greasy deposit $\frac{1}{8}$ in. thick on the plate.... | 2500° | about 550° |

Other experiments with greasy deposits showed that the temperature varied greatly, depending on the nature and thickness of the deposit.

* (Trans. Inst. Naval Architects, 1893, also Donkin, "Heat Efficiency of Steam-boilers," p. 157.)

6. Temperature of plates when boiling water in a closed vessel at a higher temperature than 212° ; using clean water:

| | Temp. Hot Side of Plate. | Temp. of Water. | Difference. |
|-------------------------------|-----------------------------|--------------------|----------------|
| Over Bunsen burner..... | 430° | 363° | 67° |
| Do. blast forge, full blast.. | 430° | 344.5° | 85.5° |

7. Same, bottom of vessel coated with grease:

| | | | |
|--|---------------|---------------|---------------|
| Over forge-fire, grease $\frac{1}{8}$ in. thick..... | 510° | 359° | 151° |
| Over grease drier, or earthier | 550° | 351° | 199° |
| Do. and spreading the grease up the sides of the vessel.. | 617° | 80° | 537° |

8. Experiments to determine whether at higher steam-pressures there is any marked addition to the excess of temperature of the hot side of the plate over that of the water showed no marked addition.

Effect of Circulation upon Economy.—In the above discussions concerning the several conditions which have an influence on the economy of a steam-boiler, nothing has been said of the effect of circulation of the water. It is contended by some writers that some boilers have a more active circulation of water than others, and that the transmission of heat, and therefore the efficiency of the heating surface, is greater the more rapid the circulation; but the author is not aware that this view is supported by the results of trials of steam-boilers. It is well known that a steam-radiator used for heating air transmits a vastly greater quantity of heat when the air is blown upon it by a fan than when the air surrounding it is comparatively still—that is, merely moving upward at the velocity of the ascending column of heated air; also that a coil used for heating water is more effective when the water is given a rapid motion; the reason being that the rapid circulation of the air, or water, constantly removes from the heating surface the heated body and replaces it with a cool one, and the rate of transmission increases approximately as the square of the difference of temperature on the inside and outside of the coil. The case is entirely different with steam-boilers. There is in all modern forms of boilers a rapidity of circulation sufficient to keep all the water surrounding the heating surfaces at nearly the temperature of the steam, so that the difference of temperature on the two sides of a square foot of heating surface, with uniform furnace conditions, remains practically constant.

If there should be a film of steam, or a “steam-pocket,” on one side of the surface, keeping the water from wetting it, the transmission of heat would be greatly diminished, so that there might even be

danger of the plate becoming overheated; but this condition is unlikely to happen in boilers of any of the ordinary forms.

Upon this subject Charles Whiting Baker writes as follows :*

So far as the transmission of heat upon the boiler is making steam is concerned, the circulation of the water in boilers is of a good deal less consequence than has sometimes been claimed. I do not mean by this that it is not worth while to make proper provision for circulation. There are possibly some boilers worked with forced draft, such as the tube-plates of marine boilers, where it is so difficult for the steam-bubbles to get away fast enough that we have a mass of foam instead of water in contact with the plate. Under such conditions, of course, the plate is bound to be heated; but I know of no evidence that this is any other than a rare occurrence, even in boilers which are pushed most severely. . . . Let it be understood that I am referring to circulation only as affecting the transfer of heat and the consequent economy and capacity of the boiler. Good circulation is desirable to prevent unequal heating of the boiler, and consequent straining, and it may be desirable in preventing deposits of scale and mud in places where they are least desirable; but that it has any appreciable effect on economy and capacity is not proved, and probably cannot be.

Dr. Charles E. Emery, in a discussion on "Tubulous Boilers," says : †

Our original conception of "convection" or "circulation" is exemplified in all boilers of ordinary type. Multiplication and various arrangements of the tubes make this circulation more and more active without changing its nature until, with the very small tubes referred to by Mr. Thornycroft, the action becomes violent and somewhat intermittent, like a geyser.

We then have this progression: a boiler in which the circulation is like that in a kettle, with steam and water rising at the centre and water descending at the sides, will operate satisfactorily; so, also, special and sectional boilers provided with water up-takes and down-takes, from the heating surface to a separate drum, will circulate on the same principles and operate satisfactorily. Curiously, this will be the case whether the up-takes be large or considerably contracted. We know that vertical boilers will operate well when there is a large space around the tubes for circulation; but the naval launch boilers and Mr. Manning's modification of the same, where the shell is brought in close to the tubes till it acts like a corset to prevent free circulation, also operates well. So, also, a locomotive boiler, with plenty of room around the tubes, operates well, and it also operates well when there is very little room around the tubes; the fact being that, with a large area of down-take, a large quantity of water is moved at a slow velocity, while with less area a less quantity of water

* Trans. A. S. M. E., vol. xix. p. 579.

† Journal Am. Soc. of Naval Engineers, vol. ii. No. 3.

is moved, but at a higher velocity, produced by a greater head, due to the fact that less water is mixed with the steam during its upward movement and the density of the column is less. The extreme of this progression is a tube so long and narrow that, with solid water fed into the bottom, the greater part of the tube will be a mass of foam, and mixed steam and water be discharged continuously or spasmodically at the upper end. It is, moreover, found that the steam and water of which the foam is composed can be separated in smaller space than is required with less vigorous ebullition. In other words, contrary to our old ideas of large steam-space, large disengaging surface and quiet ebullition to prevent foaming, we can apparently obtain as good results in a boiler composed of long, narrow tubes, each of which foams vigorously, perhaps spasmodically, in true geyser style, though not foaming in the sense ordinarily understood where water is carried to the engine.

In ordinary boilers the steam passes upward and bubbles through the water at the disengaging surface, which plan operates satisfactorily but with the geyser type of boilers there are differences of opinion whether or not it is best to discharge the upward current of mixed steam and water under the surface of the water in the drum or entirely above it. Mr. Thornycroft advocates the latter, and this system is adopted with modifications in the Ward and Belleville boilers.

A gentleman discussing Mr. Thornycroft's paper claims, however, that it is better to discharge the water and steam from small tubes below the water-level in separating-drum. It may still be considered doubtful which system will carry least water to the steam-pipe. In the end it will probably be found that each mode of operation is adapted to a particular set of conditions.

Efficiency does not Depend on the Type of Boiler.—It will be shown in the chapter on Results of Trials of Steam-boilers that boilers of a great variety of types have all given practically identical economic results, approaching the maximum possible results when the operating conditions are favorable, but the following extract from the same discussion of Dr. Emery, quoted above, may be given here:

The economy of a boiler does not depend upon its type, or the particular way the water is circulated, but upon the simple principle that when there is proper circulation of both the water and the products of combustion, the economic result is a function of the average quantity of combustible burned per square foot of heating surface. It is important that there be proper circulation, not only of the water, but of the products of combustion. Many special boilers have large chambers and curious-shaped passages, so arranged that the products of combustion do not necessarily pass over all portions of the heating surface; the current takes the lines of least resistance, and while the surface actually passed over is very efficient, the average efficiency is low.

It being settled that the economy of the different types of boiler is

based on the same law, the efficiency is frequently very low, which is due generally to the improper distribution of the heated gases over the heating surfaces, whereby a large portion of the gases can take a short circuit to the stack. This difficulty is easily overcome in ordinary boilers by reducing the cross-area for draft, so that the whole heating surface becomes efficient, which can be done if the products of combustion either pass through fire-tubes or between water-tubes. With tubulous boilers it is more difficult, as all possibility of direct access must be given up if the tubes are massed closely together in a flue. In the writer's opinion, the best form of boiler for reasonable rates of combustion is one with inclined tubes connected by up-takes and down-takes to a chamber or drum above, as in many sectional boilers.

APPENDIX TO CHAPTER IX.

NOTE 1, p. 208.—The integration may be done as follows:
Let $(T - t) = x$, $d(T - t) = dT = dx$, t being a constant.

$$\frac{dT}{(T - t)^2} = x^{-2} dx; \quad \int_{T_2}^{T_1} x^{-2} dx = -\frac{1}{T_1 - t} + \frac{1}{T_2 - t};$$

$$\frac{S}{acw} = \frac{1}{T_2 - t} - \frac{1}{T_1 - t}.$$

After finding this formula Rankine proceeds as follows (“Steam-engine,” p. 265):

$$\text{Efficiency} = \frac{T_1 - T_2}{T_1 - t} = \frac{S(T_1 - t)}{S(T_1 - t) + cwa}.$$

Let H = expenditure of heat in raising the temperature of the hot gas above that of the water. Then $T_1 - t = H \div cw$, whence

$$\frac{T_1 - T_2}{T_1 - t} = \frac{SH/cw}{SH/cw + acw} = \frac{S}{S + ac^2w^2/H}.$$

Again, p. 293, Rankine says:

“Let E = theoretical evaporative power and E_1 = available evaporative power of 1 lb. fuel, in a boiler in which the area of heating surface is S . Then

$$\frac{E_1}{E} = B \cdot \frac{S}{S + ac^2w^2/H},$$

where B is a fractional multiplier to allow for various losses of heat, whose value is to be found by experiment. Now c^2w^2 is proportional to $F^2 V_0^2$, where F = lbs. of fuel burned in the furnace in a given time, and V_0 is the volume at 32° of the air supplied per lb. of fuel. Also $H \propto F \times$ a constant. Hence it may be expected that the efficiency of a furnace will be expressed to an approximate degree of accuracy by

$$\frac{E_1}{E} = \frac{BS}{S + AF},$$

where A is a constant to be found empirically, and is probably proportional approximately to the square of the quantity of air per lb. of fuel.”

This is Rankine's formula for efficiency as a function of the heating surface, which is often quoted, but it is not generally known that his so-called "efficiency," $\frac{E_1}{E} = \frac{T_1 - T_2}{T_1 - T}$, is quite different from the efficiency as defined by Hale and others, viz., $\frac{E_a'}{E_p} = \frac{T_1 - T_2}{T_1}$, which corresponds to what is commonly known as "the efficiency of a boiler." Suppose in a given case $T_1 = 2400$, $T_2 = 600$, $t = 300$. Then $\frac{E_a'}{E_p} = \frac{T_1 - T_2}{T_1} = \frac{1800}{2400} = 75$ per cent efficiency, while Rankine's formula would give $1800 \div 2100 = 85.7$ per cent. The coefficients A and B are given by Rankine as follows:

| | | |
|--|---------------|-----------|
| | <i>B.</i> | <i>A.</i> |
| Boiler Class I. The convection taking place in the best manner, either by introducing the water at the coolest part of the boiler and making it travel gradually to the hottest, or by heating the feed-water in a set of tubes in the up-take; the draft produced by a chimney..... | 1 | 0.5 |
| Boiler Class II. Ordinary convection, chimney draft..... | $\frac{1}{2}$ | 0.5 |
| Boiler Class III. Best convection, forced draft..... | 1 | 0.3 |
| Boiler Class IV. Ordinary convection, forced draft..... | $\frac{1}{2}$ | 0.3 |

No satisfactory reason is given for the adoption of these values. These coefficients of Rankine are quite different from the A and B of the formula (8) and (9) on page 209.

NOTE 2, p. 208.—To obtain formula (5) we have

$$\frac{E_a'}{E_p} = \frac{T_1 - T_2}{T_1} \quad \dots \quad (1) \quad \frac{S}{cwa} = \frac{T_1 - T_2}{(T_2 - t)(T_1 - t)} \quad \dots \quad (4)$$

$$T_1 E_a' = T_1 E_p - T_2 E_p; \quad T_2 = T_1 \frac{(E_p - E_a')}{E_p}$$

Substituting this value of T_2 in (4),

$$\begin{aligned} \frac{S}{cwa} &= \frac{T_1 - \frac{T_1 E_p - T_1 E_a'}{E_p}}{(T_1 - t) \left(\frac{T_1 E_p - T_1 E_a'}{E_p} - t \right)} = \frac{T_1 E_a'}{(T_1 - t) [(T_1 - t) E_p - T_1 E_a']} \\ &= \frac{T_1 E_a'}{(T_1 - t)^2 E_p - (T_1 - t) T_1 E_a'} \end{aligned}$$

Put $\frac{acw}{S} = P$, and $(T_1 - t) = T_3$.

Then $P = \frac{T_3^2 E_p - T_3 T_1 E_a'}{T_1 E_a'}; \quad (PT_1 + T_3 T_1) E_a' = T_3^2 E_p;$

$$\frac{E_a'}{E_p} = \frac{T_3^2}{PT_1 + T_3 T_1} = \frac{T_3^2 \div T_1}{T_3 + P} = \frac{(T_1 - t)^2 \div T_1}{(T_1 - t) + \frac{acw}{S}} \quad \dots \quad (5)$$

NOTE 3, p. 210.—*Interpretation of formula (7),* $E_a' = BE_p - A \frac{W'}{S}$.

—If $\frac{W'}{S} = 0$, $E_a' = BE_p$. That is, the evaporation per lb. of fuel will be the greatest when the evaporation per sq. ft. of heating surface is least. (This will not be true when radiation is considered.)

If $A \frac{W'}{S} = BE_p$, or $\frac{W'}{S} = \frac{BE_p}{A}$, $E_a' = 0$. This seems to be a paradox, for can there be any rate of evaporation at which the economy, or the evaporation per lb. of fuel, will be 0? Substituting for W' its value FE_a' , we have $E_a' = BE_p - \frac{AE_a'F}{S}$; and for $E_a' = 0$, $BE_p = \frac{AF \times 0}{S}$, which, if BE_p , A , and S are finite quantities, can only be true if $F = \infty$. That is, when $W'/S = BE_p/A$, a finite quantity, the fuel consumption is infinite, and any actual evaporation, as W , divided by infinite $F = 0$.

The conclusion is that a rate of evaporation per sq. ft. of heating surface equivalent to $W'/S = BE_p/A$ can never be reached until the fuel consumption F is so great that the final temperature of the gases T_2 equals their initial temperature T_1 , which can occur only with no transmission of heat through the heating surface, or with an infinite fuel consumption.

NOTE 4, p. 211.—*Development of equation (11).*

$$E_a = BE_p - A \left(\frac{W}{S} + R \right) - \frac{RS E_a}{W};$$

$$E_a + \frac{RS}{W} E_a = BE_p - A \left(\frac{W}{S} + R \right);$$

$$E_a = \frac{BE_p}{1 + \frac{RS}{W}} - \frac{A \left(\frac{W}{S} + R \right)}{1 + \frac{RS}{W}}.$$

The last term equals $A \frac{W}{S}$; therefore $E_a = \frac{BE_p}{1 + \frac{RS}{W}} - A \frac{W}{S}$.

CHAPTER X.

TYPES OF STEAM-BOILERS.

Evolution of Different Forms of Boiler.—The first stage in the development of steam-boiler construction beyond the plain cylinder boiler was the recognition of the fact that it is defective in providing too little heating surface for its first cost, for the ground space it

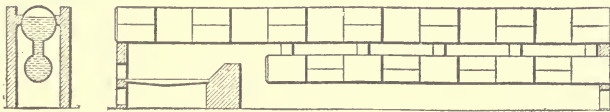

FIG. 54 —DOUBLE-CYLINDER BOILER.

occupies, and for the expense of its setting. Only about one-half of its whole shell surface is available as heating surface; the remainder serves only to hold the steam. Increase of its diameter involves increase of the thickness of its shell, and hence greater cost per square foot of heating surface, as well as increase of area occupied. Increase of its length involves equal increase of ground space and of cost of setting, besides increasing the difficulty of suspending it in such a manner as to avoid dangerous strains. Some radical change of form must then be found. In the United States the first departure from the plain cylinder boiler was made in two different directions in different localities. In blast-furnaces additional heating surface was provided by hanging one cylindrical shell below another, joining the two by short legs. Such a construction is shown in Fig. 54. The upper cylinder was generally made of larger diameter than the lower. On the Ohio and Mississippi rivers, steamboat boilers were made by enlarging the diameter of the cylinder and by putting two flues inside of it, the gases passing under the boiler and then returning through the two flues to the chimney, which was placed at the front of the boiler. This form is shown in Fig. 55. This boiler came into universal use on the western rivers, and into quite general use in the cities

and towns located along these rivers. About fifteen years ago scarcely any other kind of boiler was in use in the large iron-mills and in the mines in and around Pittsburg, such is the force of local custom and

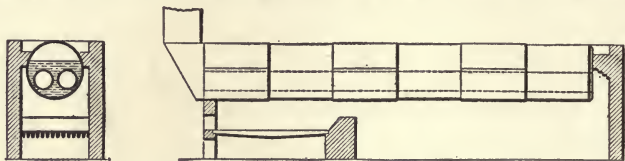

FIG. 55.—TWO-FLUE BOILER.

prejudice. Now, however, it is rapidly being displaced on land by modern water-tube boilers, although it still holds its own on the steamboats.

Evolution of the Steam-boiler in France and England.—In France the development from the plain cylinder boiler took a form similar to that of the double-cylinder boiler, but with two lower cylinders hanging from the upper one, as shown in Fig. 56. This boiler is commonly called the "elephant" boiler.

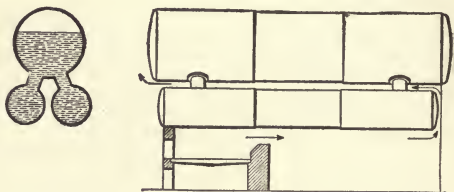

FIG. 56.—THE "ELEPHANT" BOILER.

In England the plain cylinder boiler developed into the Cornish boiler, in which the cylinder is made of larger diameter and a large central flue is built into it, in one end of which the grate is placed. This boiler is shown in Fig. 57. A modification of the Cornish boiler is the Lancashire, containing two internal furnaces and flues, shown in Fig. 58. Another modification is the Galloway boiler, in which the two internal furnaces lead into

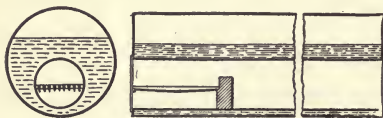

FIG. 57.—THE CORNISH BOILER.

one large flue, oblong in cross-section, crossed by a number of conical-shaped water-tubes, which circulate the water from the space below

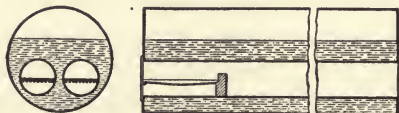

FIG. 58.—THE LANCASHIRE BOILER.



FIG. 59.—THE GALLOWAY BOILER.

to the space above the flue, baffle the course of the gases through the flue, and provide increased heating surface, as is shown in Fig. 59. The Lancashire boiler is now often built with Galloway tubes crossing

each of its flues, as shown in Fig. 60. This cut also shows, in cross-section, the common form of setting of Galloway and Lancashire boilers. The gases first pass through the internal flues, then return in the two external flues along each side, and finally pass through the single flue under the shell of the boiler. Sometimes the gases are made to pass to the front under one side of the shell and then return to the rear under the other side. All of the boilers above described are open, although to a smaller

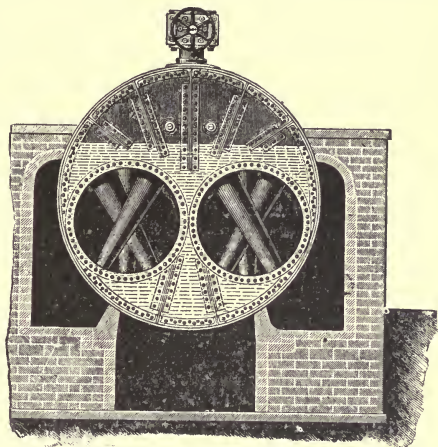

FIG. 60.—LANCASHIRE BOILER WITH GALLOWAY TUBES.

degree, to the same objection that has been raised against the plain cylinder boiler—that of providing too small an amount of heating surface for their cost and for the ground space occupied. The objection applies less to the Galloway than to the other forms.

The Horizontal Return Tubular Boiler.—The American two-flue externally fired boiler has developed through the stages of five and ten flues into the modern American horizontal multitubular externally fired fire-tube boiler, containing often 100 tubes or more, of 3 or 4 inches diameter, shown in Figs. 61 and 62.

Fig. 61 shows the most recent form of this boiler with butt and strap riveting on the longitudinal seams, adapted for high pressures. Fig. 62 shows an earlier form for moderate pressures, with the common style of setting. The steam-drum shown on this boiler is now generally abandoned, being considered a useless and even dangerous appendage.

In the return tubular boiler the objection of insufficient heating surface in proportion to space occupied, is removed to a greater extent than in any other boiler with the exception of some forms of water-tube boilers, and in regard to cost it is about the cheapest of all boilers for a given extent of heating surface. It is probably in more general use

in the United States than any other form of boiler. As already stated, it is practically not used at all in England, where there is a strong prejudice against it and in favor of the internally fired Lancashire and Galloway boilers. Its extensive introduction into this country is no doubt due to its low first cost. When well made of good material, when the water used is reasonably free from scale-forming substances,

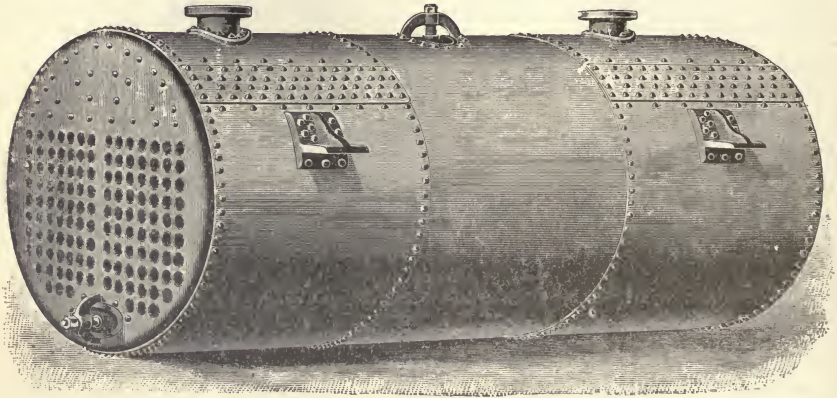

FIG. 61.—HORIZONTAL RETURN TUBULAR BOILER.

and when it is carefully handled and frequently inspected, it may give satisfaction for long periods of time, and so justify the favor in which it is held. This type of boiler is, however, very liable to explosion, and many lives are lost by its use every year. The shell of the horizontal tubular boiler being directly exposed to the fire, it is especially liable to be burned or weakened when there are deposits of scale or grease upon it. The circular rivet-seams, and the double thickness of plates at the seams being exposed to the fire, are also elements of weakness.

As to economy of fuel, the horizontal tubular boiler is subject to the same rules as all other boilers. Maximum economy may be obtained from it if the furnace is of a kind which will burn the coal thoroughly, if the extent of heating surface is sufficient for the amount of coal burned, and if the passages through the flues are so restricted in area that the gases traverse the upper and lower rows with approximately the same velocity. It is in this latter condition that the horizontal tubular boiler is usually defective. There is a tendency of the hot gases to pass through the upper rows of tubes instead of through all the tubes alike. This is easily proved by inserting a stick of wood,

say $1 \times 2 \times 10$ inches, set edgewise, in the end of each tube in a vertical row, nearest the chimney, and leaving it there for say half an hour. The sticks in the upper tubes will usually be found to be burned up, while those in the lower tubes will be only charred. This short-circuiting of the gases may be avoided by partially restricting the flow

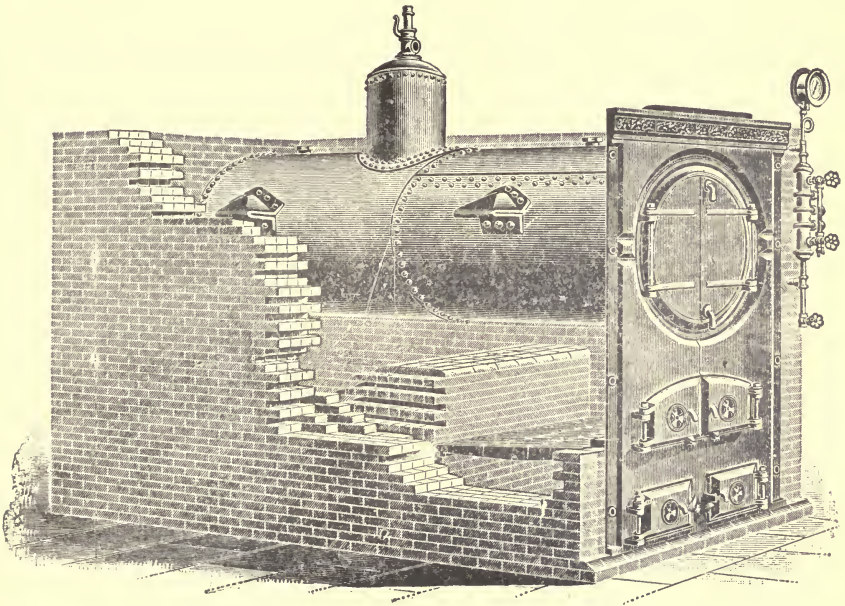

FIG. 62.—RETURN TUBULAR BOILER WITH SETTING.

through the upper tubes, but it would require considerable experimenting, by placing thermometers in several of the tubes, and varying the relative obstruction to the current in the different tubes until all of the thermometers showed the same temperature. Actual tests of tubular boilers show results varying all the way from about $11\frac{1}{2}$ lbs. of water from and at 212° per lb. of combustible, down to 8 pounds, or about 30 per cent, with no difference in the coal, the rate of combustion or the character of the firing to explain the variation. It is probable that in such cases some of the low figures are due to short-circuiting of the gases, which might be avoided by properly retarding the flow through the upper tubes.

The Vertical Tubular Boiler.—If a horizontal tubular boiler is filled with tubes, turned up on end and set over a furnace, it becomes

a vertical fire-tube boiler. It is more common, however, to build this type of boiler with an internal fire-box from 2 to 4 ft. in height. The annular space, 2 or 3 in. wide, between the fire-box and the shell, is known as the water-leg. The roof of the fire-box, a flat sheet into which the lower ends of the tubes are expanded, is called the crown-sheet, and the flat sheet on top of the boiler into which the upper ends of the tubes are expanded, is called the upper tube-sheet. The external appearance of such a boiler is shown in Fig. 63. The crown-sheet is just below the hand-hole plate seen in the front of the shell some distance above the fire-door.

This boiler is the most commonly used type of boiler in the United States for small powers, say 5 to 40 H.P. It is also the most dangerous form, and the one which explodes oftener than any other. As commonly built, the water-level is carried a considerable distance below the upper ends of the tubes, which are therefore apt to be overheated and unduly expanded, bringing severe strains on both the upper tube-sheet and the crown-sheet. The crown-sheet is apt to accumulate a thick layer of mud and scale, which is liable to cause the sheet to crack, and this may lead to an explosion.

Increased safety with this type of boiler is obtained by so constructing it that the upper ends of the tubes are submerged, and by providing facilities for inspection and for the removal of scale from the crown-sheet.

The vertical tubular boiler is usually not economical of fuel, on account of its being designed with too small an amount of heating surface for the amount of coal burned in its fire box, but it may be made as economical as any other boiler if properly designed and if driven at not too high a rate. The fire-box is usually too low to allow of complete combustion of the gases distilled from soft coal, even semi-bituminous, and the fire-tubes are too short to absorb the desired amount of heat from the hot gases. Recent designs are much better in these respects. Tubes are made as much as 18 or 20 ft. long, and fire-boxes as high as 8 ft. from the grate-bars to the crown-sheet have been built, with good results as to economy and smokelessness with semi-bituminous coal.

The **Webber Vertical Boiler**, Fig. 64, is set above a conical fire-brick furnace. The combustion-chamber is of the corrugated type, to allow of expansion and contraction, as well as to provide sufficient strength without the use of stay-bolts. The hot gases, after passing through the combustion-chamber and the short tubes of large diame-

ter above it, enter the brick-lined hood at the top of the boiler, and then pass downwards through the long tubes, of smaller diameter, around the outer circumference of the boiler, and are discharged into the annular flue at the bottom. The wall of the furnace is perforated with a number of small openings through which air may be admitted above the fire, in order to burn the smoky gases distilled

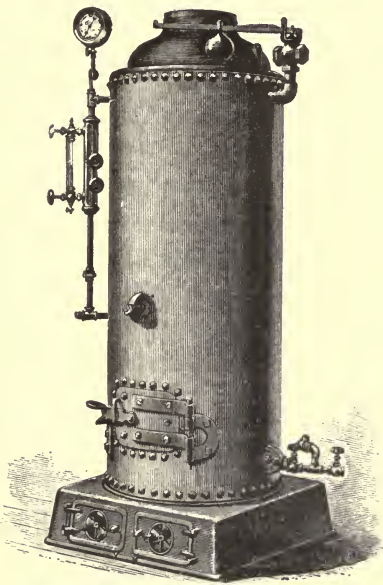

FIG. 63.—THE VERTICAL TUBULAR BOILER.

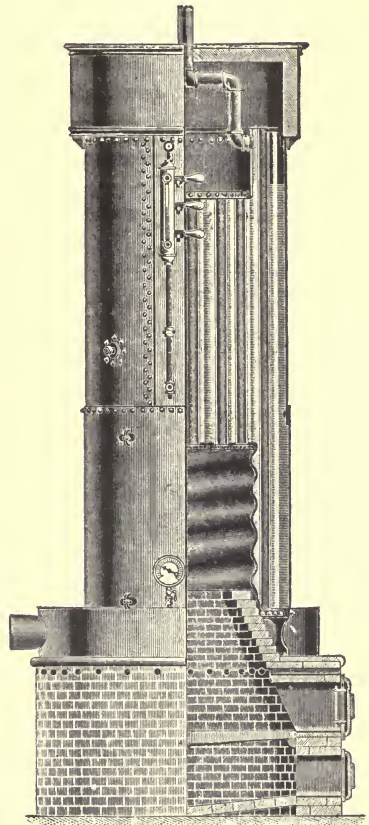

FIG. 64.—THE WEBBER VERTICAL BOILER.

from the coal. The great distance of the bottom flue-sheet from the grate-bars, together with the conical brick furnace, are calculated, when the firing is carefully done, to secure nearly perfect combustion.

The Manning Boiler, Fig. 65, is a modification of the vertical tubular boiler, with structural features peculiar to itself. It is largely used in the New England States. An especial merit claimed for it is economy of ground space. A boiler which has given 180 boiler horsepower is set on a space 8 ft. in diameter. The difference in expan-

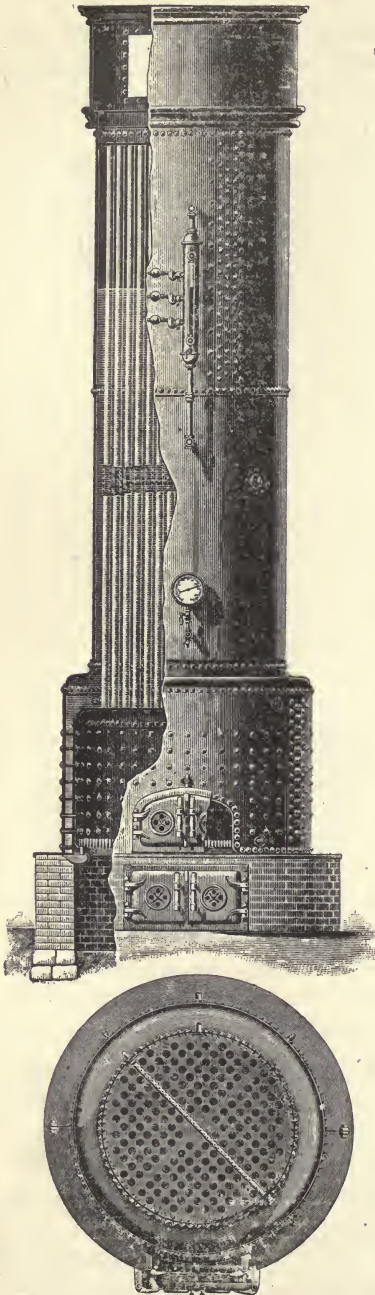

FIG. 65.—THE MANNING BOILER.

sion and contraction between the tubes and the outer shell is taken up in the double-flanged head connecting the barrel of the boiler with the outside of the fire-box, and forming an expansion joint. By means of this head the fire-box is enlarged so as to give the desired proportion of area of heating surface to grate surface. The crown is of such height to form a large combustion-chamber.

The outer fire-box shell is carried well up above the head, and hand-holes are placed exactly on a line with the crown-sheet. The tubes are placed in straight rows, and at right angles to one another extend two cleaning-channels of ample size. A bent tube may therefore be inserted, and the crown-sheet thoroughly washed and cleaned. In the water-leg also are placed a number of hand-holes and a cleaning chain by means of which any sediment that may accumulate may be stirred up and removed.

The Locomotive Boiler.—The peculiar merits of the ordinary form of locomotive boiler, as used in locomotives, are its allowing to be crowded into a limited space a great extent of heating surface, with a large fire-box, its being self-contained, requiring no external furnace, and its great strength, admitting of working pressure of 200 lbs. and over. To obtain these advantages many other things have to be sacrificed. It is expensive, difficult

to clean and to repair, is not durable, and must be driven with forced blast. It is also not economical when driven at the rate required for locomotive practice, the gases leaving the smoke-stack at high temperatures, and at rapid rates of combustion a considerable amount of unburned coal is carried out of the stack or into the smoke-box.

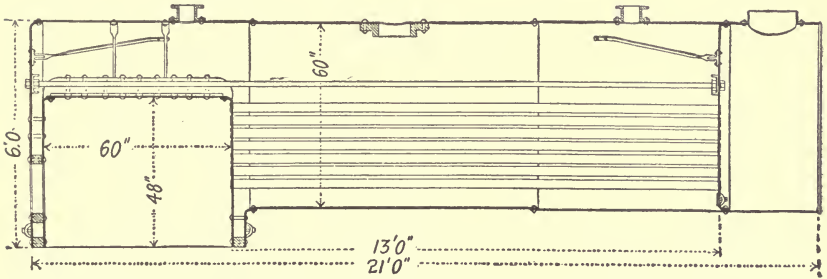

FIG. 66.—LOCOMOTIVE TYPE OF BOILER FOR STATIONARY SERVICE.

Nevertheless, the locomotive type of boiler is not uncommon in stationary practice, its chief field being for portable and semi-portable boilers. A common form of the type as used for stationary service is shown in Fig. 66.

The "Scotch" Marine Boiler.—Boilers for marine purposes are built in a great variety of types, including modifications of the externally fired horizontal fire-tube and water-tube boilers, and of the various forms of internally fired boilers, such as the vertical tubular, the locomotive, the Lancashire, etc.

Take the Lancashire boiler, Fig. 58, with its cylindrical shell and two internal furnaces, and substitute for the two smoke-flues a combustion-chamber, a tube-sheet, and a great number of small tubes, and we have the first stage of development of the Lancashire into a modern marine boiler. The next stage is to increase the diameter of the boiler and shorten its length, extending the combustion-chamber upwards and putting the nest of tubes above the furnace-flues instead of in their rear, causing the tubes to return the gases toward the front of the boiler. This makes what is known as the "Scotch" boiler, so called because it was first built on the Clyde. Increase the diameter to 14 or 15 ft., and put in three or four corrugated furnaces, and we have the latest form of the boiler shown in Fig. 67.

This boiler is often made "double-ended," that is, it is increased in length and furnaces are placed in both ends, delivering their gases into

a common combustion-chamber in the middle, from which the smoke-tubes extend to the chimney-flues at each end.

The Scotch boiler is now in almost universal use in large ocean-going merchant vessels, but in the most recent ships of war it has been displaced by the water-tube boiler.

The problem of designing a thoroughly satisfactory boiler for ocean service is one of great difficulty, and at best it offers but a choice

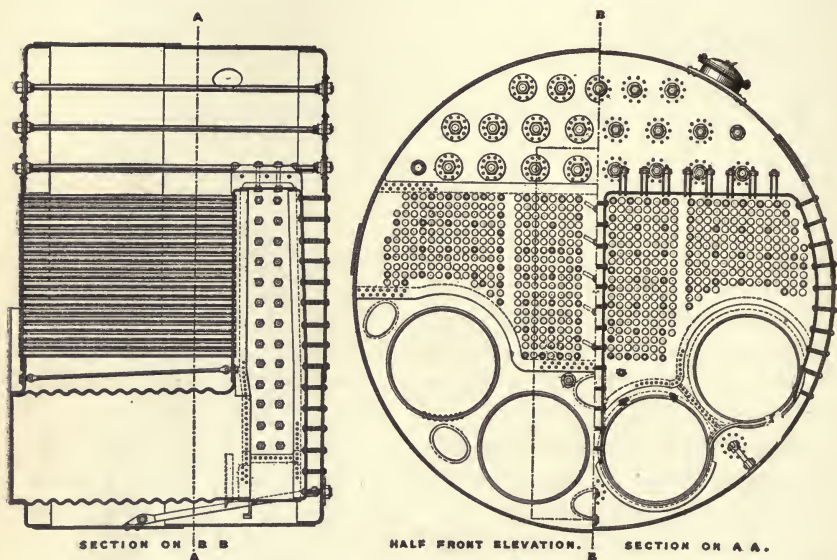

FIG. 67.—THE SCOTCH MARINE BOILER.

of evils. In stationary service, on land, a boiler to be satisfactory must have abundant grate surface, so that fires do not need to be forced; a large combustion-chamber, to help in the burning of the volatile gases, and plenty of heating surface to extract the heat from the gases. In marine service not one of these conditions can be provided, for space on board ship is too valuable. The problem may be stated thus: in a fire-room of so many square feet area and so many feet high construct boilers which shall have the greatest number of square feet of grate surface, and heating surface sufficient to absorb 65 or 70 per cent of the heating value of the coal when the coal is burned at the rate of 50 lbs. per hour per square foot of grate; at the same time the boiler must be strong, durable, easily cleaned and repaired, and must not weigh too much nor carry too much weight of water.

Until within recent years the Scotch boiler has been the one which most nearly filled these difficult requirements. It cannot fill them all, for it is heavy, both in metal and in water carried, is costly and difficult to repair.

The Water-tube Boiler.—In the water-tube steam-boiler the heating surface consists chiefly of tubes of small diameter, the water being contained in the inside of the tubes while the flame and gases of combustion are on the outside. The water-tube type of boiler forms a class broadly distinguished from the flue or tubular boiler, also called the fire-tube boiler, in which the water is contained in a large external shell and the gases pass through the flues or tubes. It is by no means a recent invention, since boilers of this type were made over a century ago, many forms of them being shown in standard treatises on boilers. It is only since the year 1870, however, that they have come into extensive use.

The great advantages of the water-tube type over all other forms of boiler, in point of safety from destructive explosions, ability to stand the highest pressures, perfection of circulation, compactness, economy of fuel, etc., were well understood many years ago, but it required a long course of development and experiment to discover what arrangement of parts and what mechanical details were necessary to combine these advantages with others not less essential, such as durability, and facility for cleaning and repair.

The form in which the water-tube boiler is now commonly made consists of a bank of tubes, usually 4 in. in diameter, and from 12 to 18 ft. long, inclined at an angle of about 15° from the horizontal, and surmounted by a horizontal water- and steam-drum, from 30 to 48 in diameter, of about the same length as the tubes. The tubes are expanded into boxes or "headers," at each end, and these are connected to the drum overhead by circulating tubes or other connections. The water-level is carried about the middle of the drum, which on account of its comparatively large diameter offers a large disengaging surface which tends to insure the production of dry steam. The furnace being placed under the bank of tubes (or better, when soft coal is used in a fire-brick oven built in front of the boiler) the flame circulates amongst them, being properly guided by suitable passages so as to cause it to give up as much of its heat as possible before being allowed to escape into the chimney.

There are now several different makes of these boilers in the market, to all of which the above description will apply. They differ,

however, in proportions of parts, in mechanical details, especially of the headers and their connection to the drum, in furnaces, in material, and in workmanship. The boiler type itself being good it still requires engineering skill and good judgment to determine what size of boiler, what kind of furnace, and what arrangement of flues and chimney should be adopted to give the best results, considering the character of work to be done, and the kind of fuel to be used.

The great success of the water-tube type of boiler is chiefly shown by the fact that it is now being most extensively adopted by the concerns which use the largest amount of power, such as electric light and power stations, cable roads, large sugar refineries, iron and steel works and the like, which require thousands of horse-power in one plant.

Early Forms of Water-tube Boilers.—Fitch & Voight's boiler, used by John Fitch in his steamboat on the Delaware River in 1787; Barlow's boiler, patented in France in 1793, and used by Robert Fulton in his steamboat experiments on the Seine, in France, in 1803, and

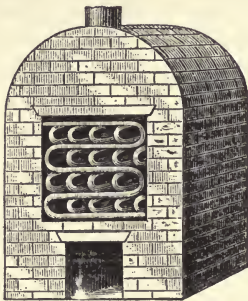

FIG. 68.—FITCH & VOIGHT, 1787.

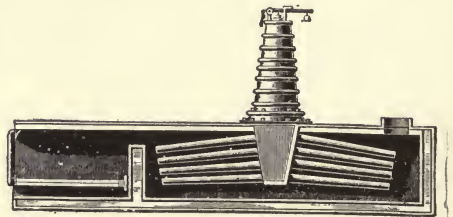

FIG. 69.—JOHN STEVENS, 1803.

John Stevens's boiler, used in his experimental twin-screw steamboat on the Hudson River in 1804, are three early forms. They are all described in Thurston's "Growth of the Steam Engine." Fitch's boiler was a "pipe-boiler," consisting of a small water-pipe winding backward and forward in the furnace, and terminating at one end at the point at which the feed-water was introduced and at the other uniting with the steam-pipe leading to the engine. Barlow's had a nest of horizontal tubes connected to water-legs at both ends. Stevens's had slightly inclined tubes, closed at one end and connected to a water-chamber at the other.

Some More Recent Forms.—The following notes, with accompany-

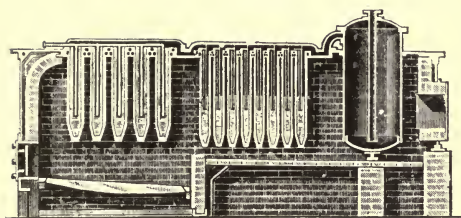

FIG. 70.—JOLY, 1857.

or arrangement of four elementary units, viz.: 1, a tube closed at one end; 2, a bent tube; 3, an aggregation of pipes and fittings; 4, a group of straight tubes connected with water-chambers at each end.

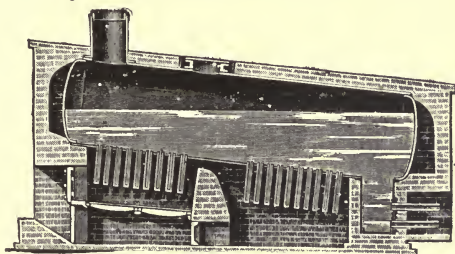

FIG. 71.—FIELD, 1866.

BOILERS WITH CLOSED-END TUBES.

Joly, 1857.—A sectional boiler with vertical drop-tubes, each fed by an in-ternal tube extending nearly to the bottom.

Field, 1866.—A cylinder boiler with radiating drop-tubes fitted to the lower side. Field also used circulating tubes inside of the drop-tube.

Fletcher, 1869.—A vertical fire-box boiler, with horizontal con-

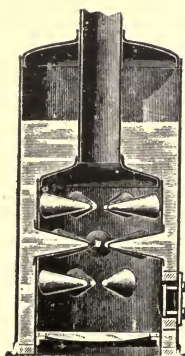

FIG. 72.—FLETCHER, 1869.

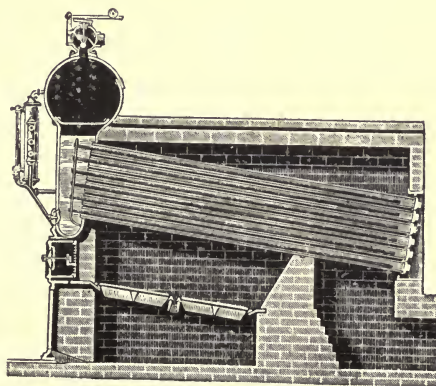

FIG. 73.—MILLER, 1870.

ing illustrations, are taken by permission from "Facts," a pamphlet published by The Babcock & Wilcox Co. in 1895. They show a few of a great number of designs of water-tube boilers that have been made by varying the form

shaped tubes radiating from the sides of the fire-box towards the centre.

J. A. Miller, 1870.—Cast headers, to which were fixed closed-end tubes, inclined about 15° from the horizontal, with inner circulating tubes.

Allen, 1871.—Cast-iron drop-tubes slightly inclined from the vertical, screwed into a horizontal tube at the top.

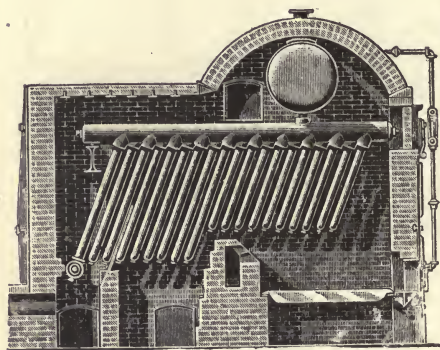

FIG. 74.—ALLEN, 1871.

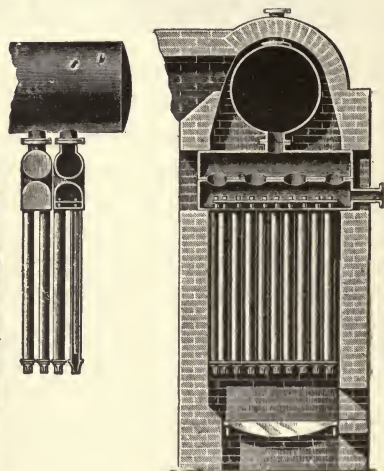

FIG. 75.—WIEGAND, 1872.

Wiegand, 1872.—Groups of vertical tubes, with inside circulating tubes, connected to an overhead steam- and water-reservoir. The lower ends of the tubes were closed by caps.

W. A. Kelly, 1876.—Similar to J. A. Miller's design of 1870, with

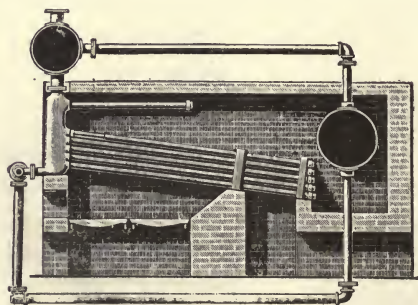

FIG. 76.—W. E. KELLY, 1876.

some additions, among them being superheating tubes for drying the steam.

Hazelton, 1883.—A vertical cylinder with radial tubes, commonly called the “Porcupine” boiler. The upper portion of this boiler is superheating surface.

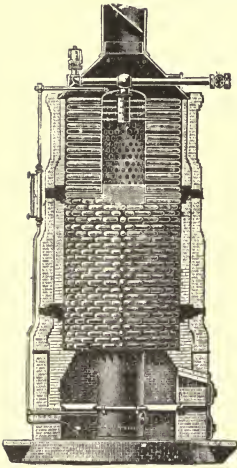

FIG. 77.—HAZELTON, 1883.

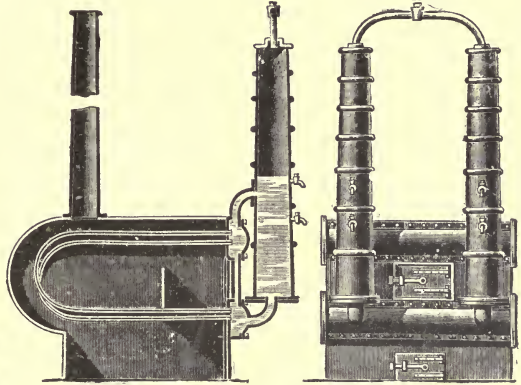

FIG. 78.—GURNEY, 1826.

BOILERS WITH BENT TUBES.

Gurney, 1826.—A pair of vertical steam- and water-reservoirs were connected at their bottom and about half way up their height by cross-pipes, from which a series of bent tubes were projected into the fire-box. The lower row of tubes served as a grate. This boiler was used in a steam road-carriage.

Church, 1832.—A locomotive fire-box with a vertical extension at one end, filled with bent tubes connecting the sides of the fire-box with the crown-sheet, and with side openings in the shape of fire-tubes extending through the shell at the top, for taking off the gases. This boiler was also used for a road-carriage.

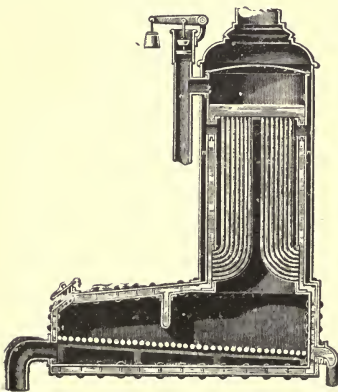

FIG. 79.—CHURCH, 1832.

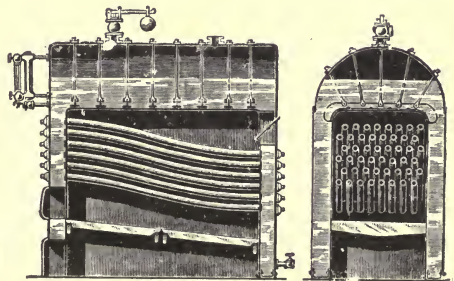

FIG. 80.—WILCOX, 1856.

Wilcox, 1856.—Stephen Wilcox was the first to use inclined tubes connecting water-spaces, front and rear, with an overhead steam- and water-reservoir. The tubes were bent with a slightly reversed curve extending nearly the whole length of the tube. In 1869 Mr. Wilcox, with his partner, George H. Babcock, bought out the Babcock & Wilcox boiler, with straight inclined tubes.

Rowan, 1865.—A series of units placed side by side, each unit consisting of an upper and a lower horizontal drum connected by a series of bent-ended heating-tubes, and at their ends, outside the setting, with down-take tubes of large diameter.

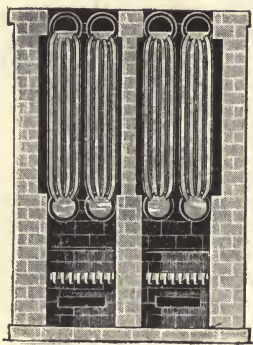

FIG. 81.—ROWAN, 1865.

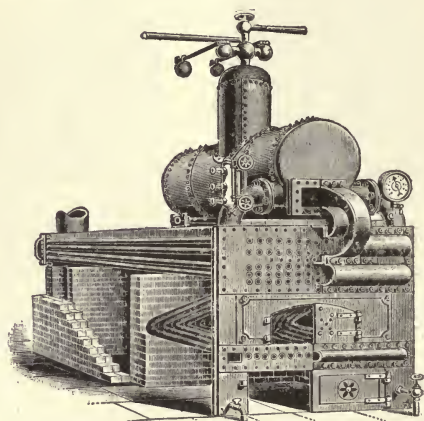

FIG. 82.—PHLEGER, 1871.

Phleger, 1871.—Gurney U tubes were used for fire-bars, with a second series added above for heating-tubes, and above them a large steam- and water-drum.

Rogers & Black, 1876.—A series of U tubes on the outside of a vertical shell, surrounded with a brick setting.

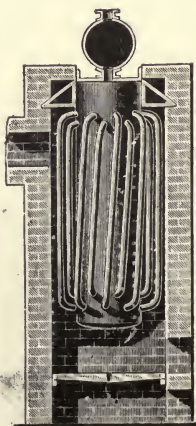

FIG. 83.—ROGERS & BLACK, 1876.

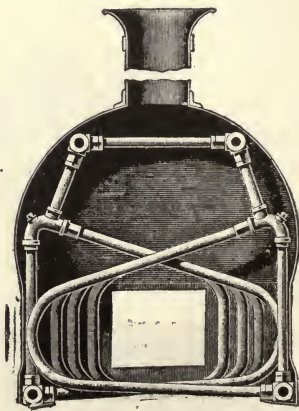

FIG. 84.—DANCE, 1833.

BOILERS BUILT OF PIPES AND FITTINGS.

Dance, 1833.—The lower tubes were used as grates. Up-flow and down-flow pipes, connected by special fittings. Steam and water capacity very small, and no provision for internal cleaning.

Belleville, 1865.—Bent U tubes screwed into return bends, a series of coils being placed vertically side by side, connected at the top to a separating-drum and at the bottom to a common feed-pipe.

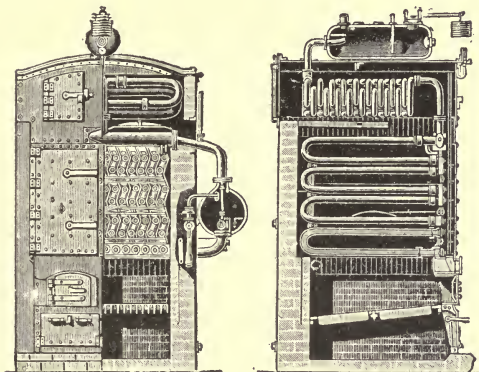

FIG. 85.—BELLEVILLE, 1865.

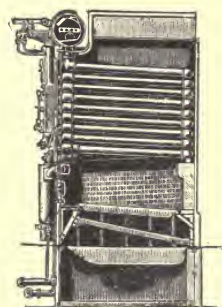

FIG. 86 —BELLEVILLE, 1877.

Belleville, 1877.—The bent pipe was discarded and return bends used on both ends of a series of straight tubes.

Kilgore, 1874.—Straight tubes with return bends, connected to cast-iron water-chambers. This boiler was introduced quite extensively in Pittsburg, but it had a very short life.

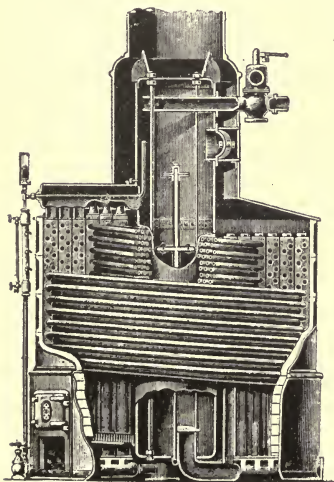

FIG. 88.—WARD, 1879.

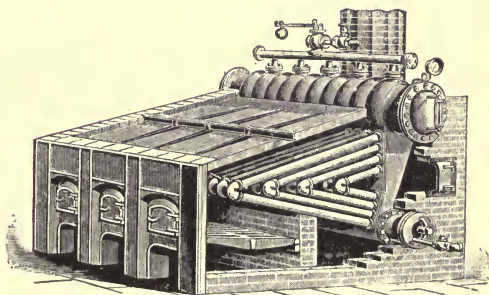

FIG. 87.—KILGORE, 1874.

Ward, 1879.—A vertical cylinder, surrounded by a series of concentric coils interrupted twice in their circumference, on opposite sides, by vertical manifolds. These manifolds on one side were connected by a radial pipe to the bottom of the cylinder, and at the other side to a circular pipe connecting near the top of the cylinder.

Roberts, 1887.—Straight pipes with return bends, with “down-take” pipes outside.

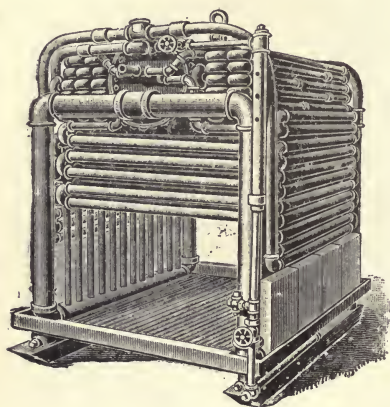

FIG. 89.—ROBERTS, 1887.

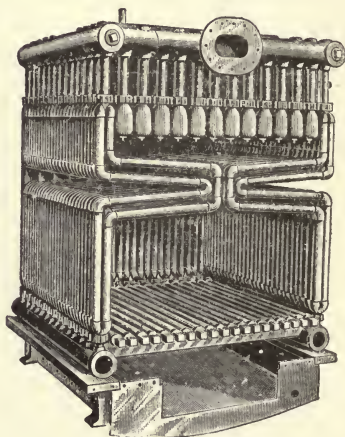

FIG. 90.—ALMY, 1890.

Almy, 1890.—Straight pipes connected with elbows and return bends to an overhead steam- and water-reservoir and bottom connecting pipes.

Herreshoff, 1890.—Straight tubes with return bends at each end.

BOILERS WITH STRAIGHT TUBES CONNECTED TO WATER-CHAMBERS AT BOTH ENDS.

Firmenich, 1875.—Flat-sided horizontal drums at top and bottom of a bank of straight tubes. Two such units were placed A-fashion, with the grates between them at the bottom, and surmounted with a steam-drum on top.

Wheeler, 1892.—Like the Firmenich, but with the tubes set vertically, and the lower water-drums directly over the grates.

Maynard, 1870.—A horizontal steam- and water-cylinder above a bank of tubes placed at a slight inclination from the horizontal; the

ends of the tubes expanded into round boxes having stayed heads connected to the horizontal drum.

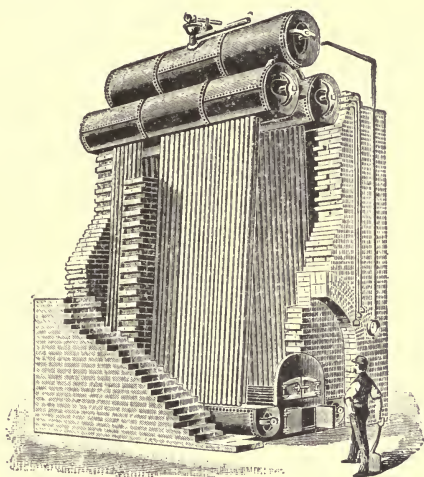

FIG. 91.—FIRMENICH, 1875.

Modern Forms of Water-tube Boilers.—The water-tube type of boiler did not come into any extensive use prior to 1870, probably

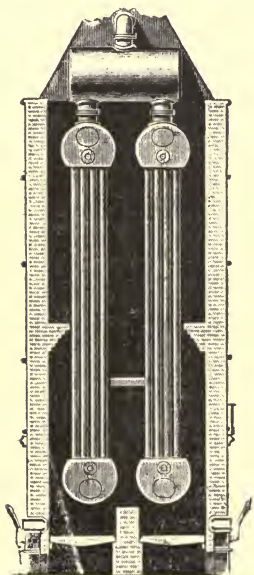

FIG. 92.—WHEELER, 1892.

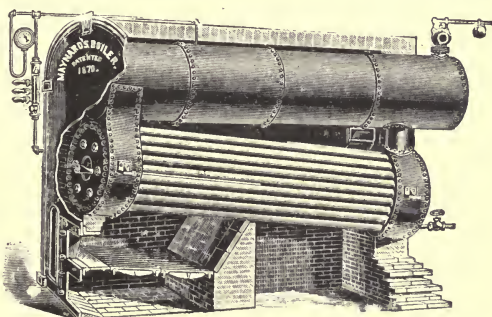

FIG. 93.—MAYNARD, 1870.

because inventors of the earlier forms did not appreciate the requirements of a thoroughly good boiler, such as facility for cleaning and repair, provisions for proper circulation of the water and of the gases of combustion, and for insuring dry steam—all of which are met in at least some of the modern forms of the water-tube boiler. In 1867 Mr. John

B. Root invented what is known as the Root boiler, and in 1869 the Babcock & Wilcox Company first put their boiler on the market. Both of these boilers have been improved in some respects since they were first brought out, the Babcock & Wilcox reaching practically its present form as early as 1873, and the Root boiler its present form about ten years later.

The **Babcock & Wilcox Boiler**, since the original patents have expired, has been extensively copied, with modifications more or less

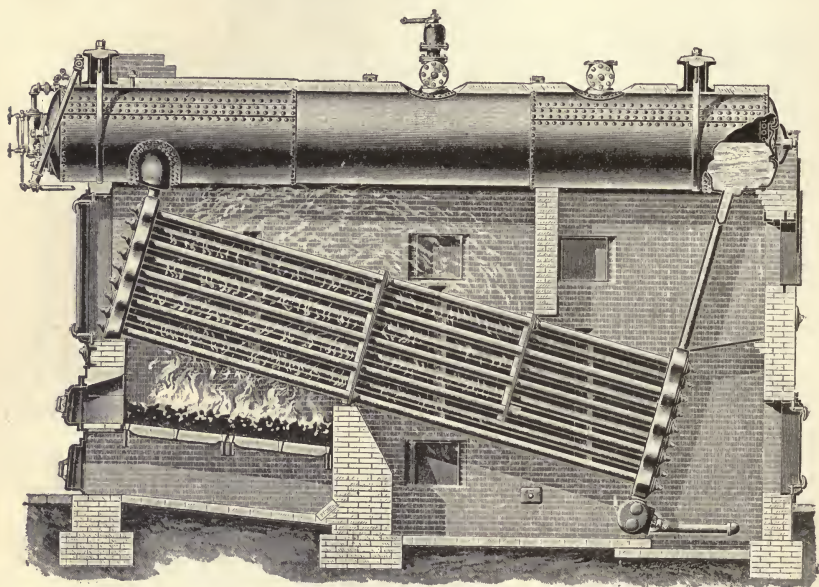

FIG. 94.—THE BABCOCK & WILCOX BOILER.

important, and its general form may now be considered a standard type of boiler, the leading features of which are a horizontal drum, usually about 36 in. diameter, the water-line being carried at the middle of the drum, and a "bank" of 4-in. tubes inclined about 15° from the horizontal, the tubes being usually laid parallel in horizontal rows across the boiler, the vertical rows being staggered. The tubes are expanded at each end into headers, which take different forms in different modifications of the general type. The front headers are connected with the drum by short pieces of tube, and the rear headers by tubes 4 to 6 ft. long.

In the most recent form of Babcock & Wilcox boiler, designed especially for high pressures, Fig. 94, the header is a long corrugated

box of forged steel, into which are expanded the tubes of one of the vertical staggered rows. Opposite the end of each tube there is a hand-hole plate, held to its seat by a bolt and nut. As the rear header, as well as the front header, is provided with similar hand-hole plates, the interior of the tube may be inspected by the boiler-owner himself, by having some one hold a candle at the hand-hole of the rear header while he looks in through the front header. The hand-holes are made of such a size that the tubes may be withdrawn or inserted through them whenever a tube requires to be replaced.

In the *National* and *Gill* boilers, the principal feature of difference from the Babcock & Wilcox boiler is the form of the headers. In the *National* boiler the header is of approximately a triangular shape, to take three tubes, while in the *Gill* boilers the headers are made, as shown in Fig. 95, to take four, five or six tubes. Each header-box is connected with the one above it by an expanded nipple.

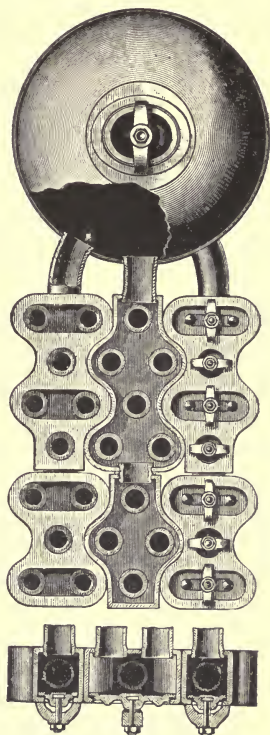

FIG. 95 — HEADERS OF THE GILL BOILER.

In the *Caldwell* boiler, Fig. 96, a departure has been made from the usual plan of staggering the vertical rows of tubes, and they are placed directly one above the other. In order to deflect the gases and cause them to completely envelop the tubes, specially shaped brick are laid across alternate spaces between the tubes as shown in Fig. 97.

The Root Boiler (Fig. 98) consists of an arrangement of 4-in. tubes, inclined about 20° from the horizontal and set in a staggered position vertically, surrounded by several horizontal steam- and water-drums about 15 ins. in diameter. The tubes are expanded into headers which with their connections form a vertical channel through which the water passes from the point where the lower tube enters them to the top. When the boiler is working, water fills the tubes, and also about half of each of the overhead drums, each one of which receives the water and steam from the vertical piles of tubes immediately below it.

In the rear of the boiler, at the end of the overhead water-drums, each drum has a vertical pipe terminating in a drum common to all

beneath it, which is placed at right angles to them; and through these vertical "down-take pipes" flows the water of circulation, which has parted with its bubbles of steam. In this cross-drum the down-flowing

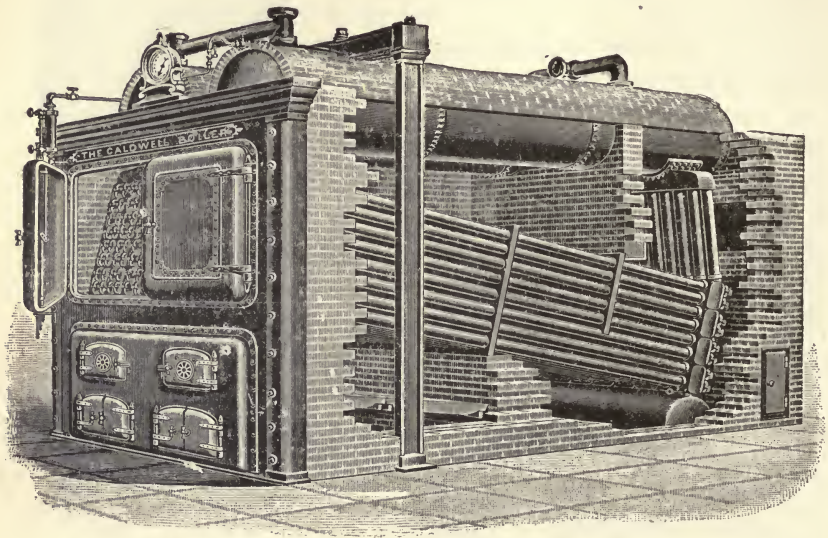

FIG. 96.—THE CALDWELL BOILER.

water meets the feed-water, which is introduced at this point, and warms it up to a temperature sufficiently high to prevent any trouble which might be caused by unequal expansion in the boiler parts from receiving feed-water at a low temperature. From this feed-drum, the mixture of feed and circulating water descends through the large vertical down-take pipes to the mud-drum beneath. After leaving the mud-drum, the water passes from the "goose-neck" connections into the extreme lower end of each one of the rear vertical sections of boiler-tubes; and then it rises up along the tubes, maintaining the constant upward flow which is always going on when the boiler is in operation.

The water, filled with its bubbles of steam, rises along the inclined tubes, and passes up along the front headers into the overhead water-drums. At the rear end of each drum the steam finds an opening into the steam-collecting multiple above, which is placed at right angles to all the drums, and from this multiple it passes along the two

connecting-pipes into the large steam and separating drum located above the water-drums about the centre of the boiler.

The details of the Root boiler are shown in Fig. 99.

No. 1 shows a "package" consisting of two tubes with a header expanded on each end. No. 2 shows these packages placed one upon the other, forming a section. Connecting-bends are also shown in place, through which a circulation of water is obtained from the bottom to the top of the section. A number of sections placed side by side go to form a complete boiler. No. 3 shows the method by which these bends are applied. Between the bend which is ready to drop in place and the header is seen the metallic packing-ring

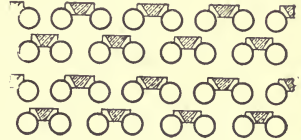

FIG. 97.—CALDWELL BOILER.

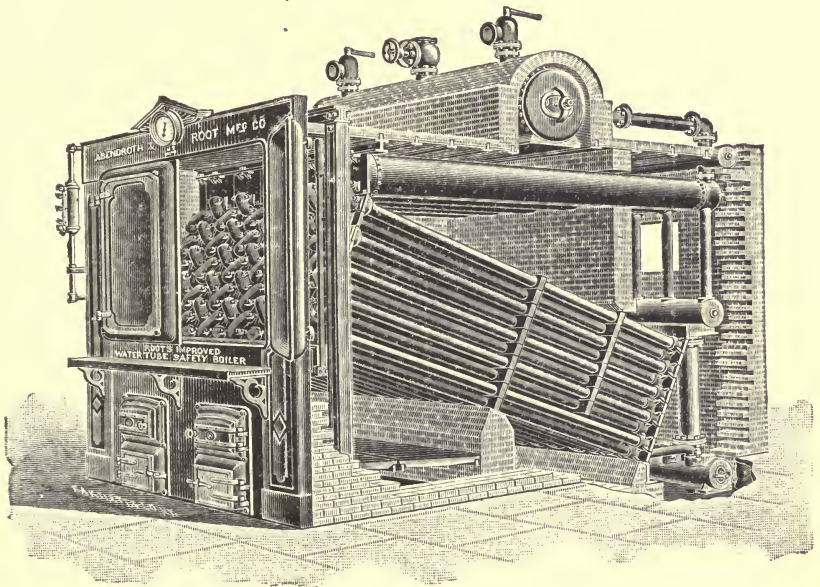

FIG. 98.—THE ROOT WATER TUBE BOILER.

which drops into the seat beneath it. This ring is shown in detail in No. 4. A sectional view, No. 6, shows it in place. All these seats are milled to exact size by special machinery, and the ring, which is made of an elastic bronze-like metal, is also finished to an exact size.

The tapered end of the connecting-bend is shown in the enlarged view, No. 5. When this plug is forced down into the tapered seat of the ring it causes the ring to expand in every direction radially, and so make a tight joint. This bend is drawn down into the seat by bolts. The heads of these bolts are ball-shaped and are received into similarly shaped sockets cast in the headers, which allow the screw-ends freedom to move in every direction.

All the water-tube boilers above mentioned, as well as many other variations of this general type, are known as sectional boilers, since they are built up of sections made by assembling a number of interchangeable parts. This sectional feature is a convenience in transportation and erection, and it facilitates the rapid making of repairs; a new section being easily substituted for an old one.

Other water-tube boilers are made which are not sectional. One of the best known is the *Heine* boiler, shown in Fig. 20, p. 165. The tubes are parallel with the drum, both being inclined at the same angle when the boiler is set up, and are connected with it at each end by large water-legs, made of plates stayed together. A hand-hole plate is opposite the end of each tube, through which the tube may be cleaned or replaced.

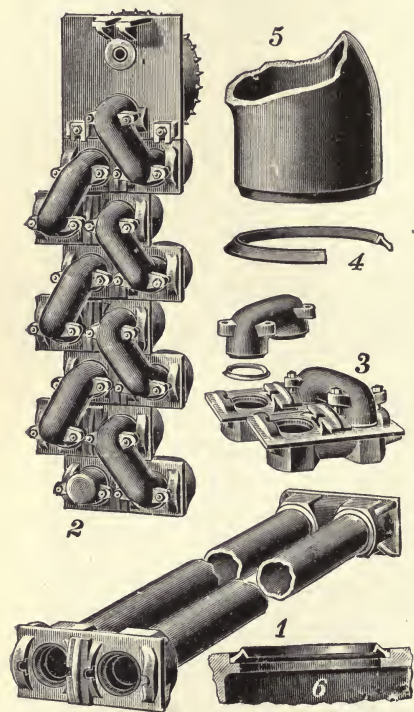

FIG. 99.—DETAILS OF THE ROOT BOILER.

It will be noticed that in the *Heine* boiler, Fig. 20, the passages for the gases of combustion are horizontal, or parallel with the tubes, while in the other boilers the gases pass transversely across the tubes three times. For anthracite coal the transverse passages are probably the best, and when properly fired this coal is thoroughly burned on the grates, and the direction of the gas-passages across the tubes offers every facility that can be desired for allowing the heating surface to

absorb the heat from the gases. With bituminous coal, the settings shown in Figs. 94 and 96 do not offer sufficient opportunity for the gases from the coal to be thoroughly burned before they reach the tubes, consequently a portion of the valuable heating gases is apt to go off unburned, since the tubes chill them below the temperature of ignition. The long horizontal passage under the lower row of tubes is better for insuring combustion of the gases, but the return passage enclosing the tubes requires to be carefully proportioned as to its sectional area, in relation to the amount of coal burned, so that the hot gases do not travel along the upper portion of the passage only, leaving the heating surface of the lower portion in effective. In adopting either one of these styles of setting, with bituminous coal, there is a choice of evils: in one style the gas may be imperfectly burned, in the other the heat from the burned gas may be imperfectly absorbed. With furnaces adapted to the complete combustion of the gases of bituminous coal, the transverse passages will usually be found preferable to the longitudinal.

The Cahall Vertical Water-tube Boiler, Fig. 100, is another non-sectional boiler. It consists, as shown, of a nest of nearly vertical water-tubes connecting a shallow water-drum at the bottom with a tall annular steam- and water-drum at the top, the size of which is sufficient for a man to walk around in it, and so be able to reach the inside of the tubes with a scraper. The coal is burned in a chamber lined with fire-brick, and the gases, after being caused to traverse the tubes in a circuitous manner, by the bafflers shown in the cut, escape out of the hole in the centre of the annular drum.

The external furnace of the Cahall boiler is well adapted to the burning of bituminous coal. There is no reason why an external oven

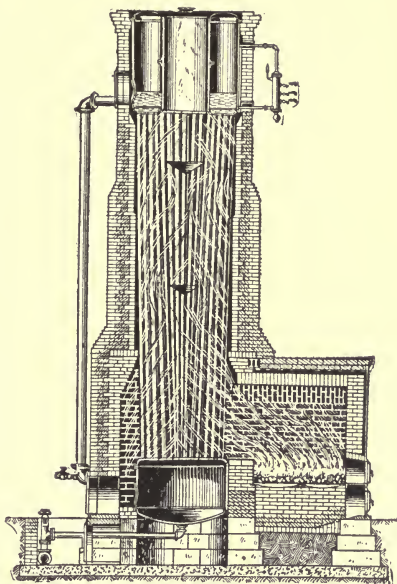

FIG. 200.—THE CAHALL VERTICAL BOILER.

or furnace cannot be used in connection with boilers of the Babcock & Wilcox type. In fact, such boilers are sometimes set with such an external furnace with advantageous results, and their more general adoption in future is probable. With the highly volatile coal mined west of the Allegheny Mountains the use of mechanical stokers, together with external furnaces, is also likely, with proper proportioning and careful handling, to improve economy.

The Stirling Boiler, Fig. 101, consists of three horizontal steam-

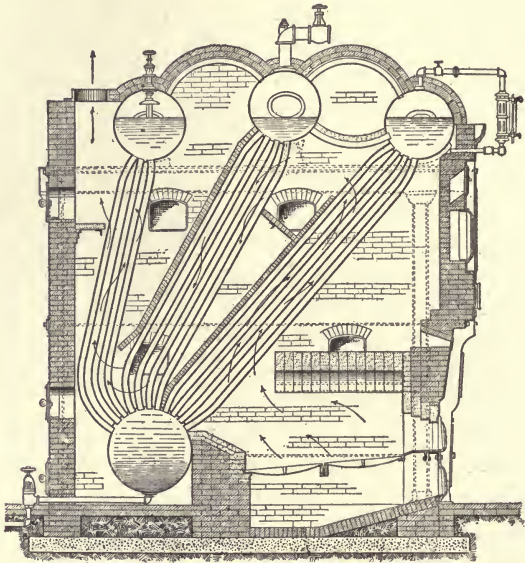

FIG. 101.—THE STIRLING BOILER.

and water-drums at the top, and a single water-drum at the bottom, connected by three sets of inclined and somewhat curved tubes. A fire-brick arch is built above the grate, and baffle-walls of fire-brick are placed above the upper rows of two of the sets of tubes, which give a proper direction to the heated gases.

The Wickes Boiler, Fig. 102, also consists of an upper and lower drum connected by vertical tubes. By building a thin wall of fire-brick between two adjoining middle rows of tubes, as shown in the cut, the passage for gas is caused to lead first upwards from the furnace and then downwards to the chimney-flue. An external furnace is used with this boiler.

out and a stop-tube, about 18 ins. long, with a welded end, is inserted in the hole from the inside of the central shell and expanded.

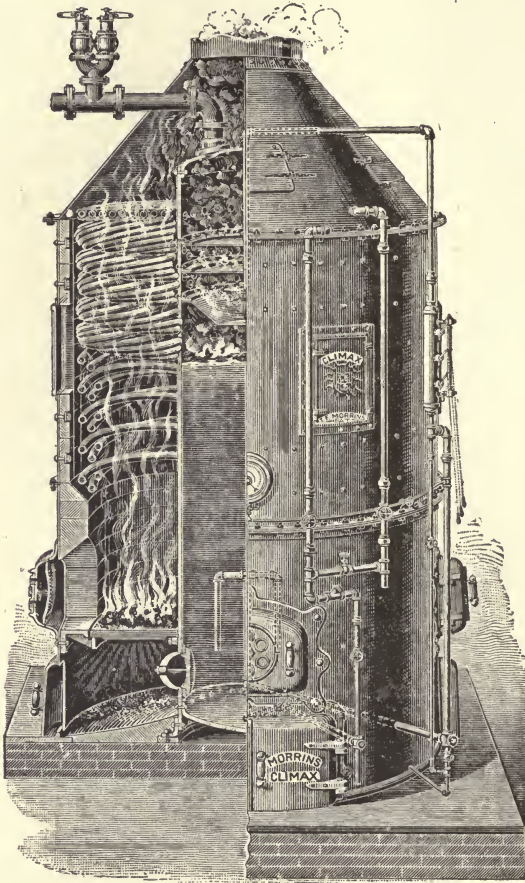

FIG. 103.—MORRIN'S CLIMAX BOILER.

Water-tube Marine Boilers.—Of the boilers built of pipes and fittings, briefly described on page 263, the Ward, Roberts, Almy and Herreshoff have been somewhat extensively used in steam-yachts and torpedo-boats. The Belleville, in its recent forms, has come largely into use in the French mercantile marine, and has been adopted in several ships of war, including large cruisers, in the British Navy. For descriptions and illustrations of many other forms of marine water-tube boilers see Bertin & Robertson on "Marine Boilers" and

W. S Hutton on "Steam-Boiler Construction." Three of these forms are described below.

The Thornycroft Boiler (Fig. 104). A large cylindrical steam-drum is connected to a lower water-drum by two groups of curved generating tubes of small diameter. The fire-grates are on each side of the water-drum. The two outer rows of tubes of each group are brought together, making a tube-wall, but so as to leave openings for the hot gases to pass between the tubes near their lower ends. The two inner rows of each group are in like manner brought together, except near their upper ends, where there are passages left between them. The gases thus pass from the combustion-chamber

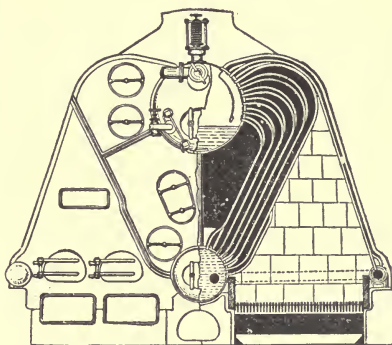

FIG. 104.—THORNYCROFT BOILER.

above the grates on each side into the flue between the outer and inner tube-walls, and thence into the heart-shaped central flue which leads to the funnel at the back of the boiler. The outer sides of the fire-box or combustion-chamber are formed by tube-walls leading from two small water-drums into the upper part of the steam-drum, these water-drums being connected by a cross-pipe at the back of the boiler. The generating tubes discharge a mingled mass of steam and water into the steam-drum, in which there are baffle-plates to separate the steam and the water. The steam passes into an internal steam-pipe through narrow slits, while the water falls to the bottom of the steam-drum and is thence conveyed by large central return-pipes to the water-drum at the bottom, thus insuring a rapid circulation. The following data of a large Thornycroft boiler are given by Hutton:

| | | |
|--|------------------|------|
| Tube surface..... | sq. ft. | 4020 |
| Fire-grate area..... | " " | 63.5 |
| Weight of the boiler and mountings, with water..... | tons | 18½ |
| Indicated horse-power on trial, with triple-expansion engines..... | | 2000 |
| Working pressure of steam..... | lbs. per sq. in. | 220 |

This boiler is known as the "Daring" type. Other and smaller boilers of the Thornycroft make are called the "Speedy" and the "Launch" types. The Thornycroft boiler is largely used in torpedo-boats and high-speed yachts, especially in Great Britain.

The Mosher Boiler (Fig. 105). Two steam- and water-drums communicate with lower water-chambers by a great number of curved tubes of small diameter, and also by two external down-take tubes, 4 inches in diameter. The front and back casings are lined with fire-brick covered with asbestos, and the upper part with a layer of soap-stone between layers of asbestos. This boiler is used in many high-speed American yachts.

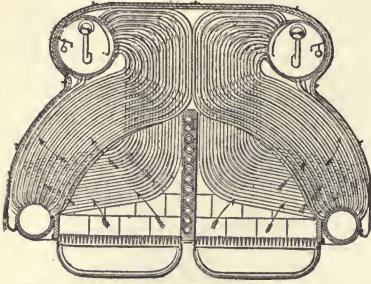

FIG. 105.—THE MOSHER BOILER.

The Babcock & Wilcox Marine Boiler of the latest form is shown

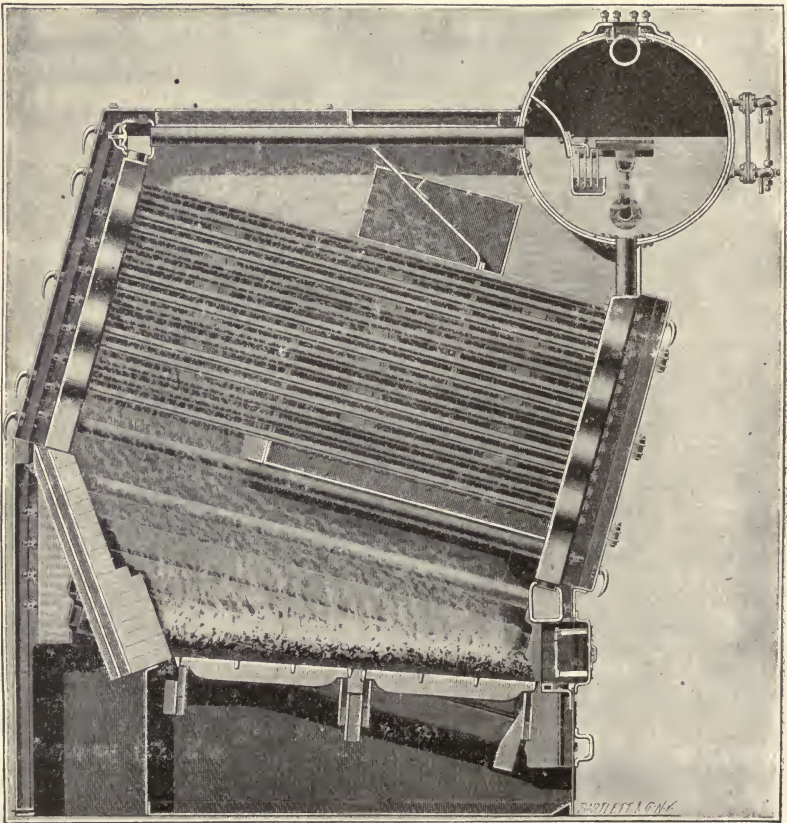

FIG. 106.—LONGITUDINAL SECTION OF BABCOCK & WILCOX MARINE WATER-TUBE BOILER, "ALERT" TYPE, SHOWING SIDE CASING REMOVED.

in Fig. 106, which represents one of the boilers of the U. S. cruiser *Cincinnati*. This boiler has been extensively adopted in the British and American navies for the largest war-vessels, and since 1895 it has been used with great success in the Wilson (British) line of merchant steamers. The chief features in which it differs from the land type of the Babcock & Wilcox boiler, Fig. 94, page 266, have been designed for the purpose, chiefly, of providing a very large area of grate and heating surface, together with relatively small weight of metal and water to be carried in the contracted space allowed in ocean steamers. The tubes in the lower row are 4 ins. diameter, all the others being 2 ins. The steam and water drum is set transversely to the direction of the tubes. The fire-box is roofed over by fire-brick supported by the lower row of tubes. The fire-door is placed at what would be called the rear of the boiler in the ordinary land boiler. A fuller description of this boiler, together with the record of a series of tests made by engineers of the U. S. Navy will be found in the chapter on Results of Steam-Boiler Trials.

Forms of Boiler used in Different Countries.—The average boiler-user is governed in his selection of a boiler largely by local custom and prejudice, and therefore different forms of boiler are the favorites in different parts of the world. To show how generally this is true, we have the following figures showing the percentage of various types of boilers used in Great Britain, France, Germany, Switzerland, and Austria, prepared by Mr. Hiller, of the National Boiler Insurance Co., of Manchester, England, and given by Mr. R. S. Hale in Circular No. 5, 1896, of the Steam Users' Association, Boston, Mass.:

PER CENT OF BOILERS OF VARIOUS TYPES USED IN EUROPE.

| | 1895. | 1893-4. | | | |
|---------------------------------|-----------------|---------|----------|--------------|----------|
| | United Kingdom. | France. | Germany. | Switzerland. | Austria. |
| Lancashire and similar types.. | 38.0 | 4.7 | 35.7 | 19.6 | * |
| Cornish and similar types ... | 23.7 | 8.2 | 15.3 | 40.8 | * |
| Externally fired cylindrical... | 46.8 | 57.3 | 14.8 | 15.5 | 41.0 |
| Externally fired multitubular. | | 13.4 | 5.2 | 3.5 | 7.5 |
| Locomotive..... | 11.0 | 5.1 | 17.3 | 5.7 | 10.5 |
| Small verticals..... | 16.6 | 3.6 | 5.0 | 13.5 | 6.1 |
| Water-tube..... | 1.8 | 5.7 | 4.6 | 1.4 | 3.8 |
| Other types..... | 2.1 | 2.0 | 2.1 | | 1.4 |

* Lancashire, Cornish, and similar types, 29.7. † Including "elephant" boilers.

We note from this table that the Lancashire, Cornish, and similar types form a majority of all the boilers in the United Kingdom, Ger-

many, and Switzerland; that the externally fired cylindrical, including the elephant boilers, are in the lead in France and Austria, and that the externally fired multitubular boiler, which is the most common boiler in the United States, does not appear to be used at all in Great Britain, and but to a small extent in other European countries. If the table had included boilers in the United States, it would probably put the externally fired multitubular boilers far in the lead of all the others, the elephant, the Cornish, and the Lancashire boilers would not appear at all, the externally fired cylindrical boilers to probably less than 5 per cent, the small verticals would probably have a larger percentage than in any country in Europe, large verticals, such as the Manning, which are not named in the European list, would appear with a small percentage, and water-tube boilers would probably have a higher percentage than anywhere in Europe.

It must be said in relation to this table, that it is not fairly representative of European practice in the purchase of new boilers at the present date, but is simply the percentage of boilers in use in 1895, including both old and new; many of them are no doubt forty years old, or more. If a table were prepared of the percentages of boilers of various types now sold, it would undoubtedly show a much higher percentage of water-tube boilers, which have within the last ten years become very common in Belgium, France, and Germany, and are rapidly increasing in favor in England as well as in the United States.

There is nothing in the steam-engine practice of different countries, nor in the character of fuel, or of water used, which will account for the great difference in boiler practice in the different countries, and the only explanation of it appears to be local custom, prejudice, and conservatism. The difference between American and European practice may be partly explained by financial considerations. In England, where manufacturing establishments are generally of many years' standing and provided with abundant capital, and where the interest on money is low, the first cost of a boiler-plant is usually a consideration of secondary importance. This has led to the general introduction of the Lancashire boiler, which is very high in first cost. In America, where most of the manufacturing concerns have grown from small beginnings, where capital for investment in manufacturing has been scarce and interest high, low first cost has been considered of chief importance, and on this account the horizontal multitubular boiler, which is almost unknown in England, has come into most extensive use. In recent years, however, in the United States, the increase of wealth, the decrease of the rate of interest, the growth of

manufacturing concerns into establishments of vast extent and abundant capital, the decrease of the margin of profit in manufactured goods, and intense competition, have all tended to bring about changes in the ideas and methods of manufacturers and other steam-users. They are now disposed to look more carefully into the questions of economy of fuel and of durability of steam-boilers, and are more willing than formerly to try boilers of higher first cost if they can be assured of an ultimate saving in annual expense.

CHAPTER XI.

BOILER HORSE-POWER—PROPORTIONS OF HEATING AND GRATE SURFACE—PERFORMANCE OF BOILERS.

The Horse-power of a Steam-boiler.—The term “horse-power” has two meanings in engineering: *First, an absolute unit or measure of the rate of work*; that is, of the work done in a certain definite period of time, by a source of energy, as a steam-boiler, a waterfall, a current of air or of water, or by a prime mover, as a steam-engine, a water-wheel, or a wind-mill. The value of this unit, whenever it can be expressed in foot-pounds of energy, as in the case of steam-engines, water-wheels, and waterfalls, is 33,000 foot-pounds per minute. In the case of boilers, where the work done, the conversion of water into steam, cannot be expressed in foot-pounds of available energy, the usual value given to the term horse-power is the evaporation of 30 lbs. of water of a temperature of 100° F. into steam at 70 lbs. pressure above the atmosphere. Both of these units are arbitrary; the first, 33,000 foot-pounds per minute, originally used by James Watt, being considered equivalent to the power exerted by a good London draft-horse, and the second, 30 lbs. of water evaporated per hour, being considered to be the steam requirement per indicated horse-power of an average engine.

The second definition of the term horse-power is an *approximate measure of the size, capacity, value, or “rating”* of a boiler, engine, water-wheel, or other source or conveyer of energy, by which measure it may be described, bought and sold, advertised, etc. No definite value can be given to this measure, which varies largely with local custom or individual opinion of makers and users of machinery. The nearest approach to uniformity which can be arrived at in the term “horse-power,” used in this sense, is to say, that a boiler, engine, water-wheel, or other machine, “rated” at a certain horse-power, should be capable of steadily developing that horse-power for a long period of time under ordinary conditions of use and practice, leaving to local custom, to the judgment of the buyer and seller, to written

contracts of purchase and sale, or to legal decisions upon such contracts, the interpretation of what is meant by the term "ordinary conditions of use and practice." (Trans. A. S. M. E., vol. vii. p. 226.)

Definitions of "Boiler Horse-power."—The question of defining the "commercial" horse-power of a steam-boiler was considered by the two committees on steam-boiler trials (1885 and 1899) of the American Society of Mechanical Engineers.* The second committee (1899) reported on this subject as follows :

The Committee recommends that, as far as possible, the capacity of a boiler be expressed in terms of the "number of pounds of water evaporated per hour from and at 212 degrees." It does not seem expedient, however, to abandon the widely-recognized measure of capacity of stationary or land boilers expressed in terms of "boiler horse-power."

The unit of commercial boiler horse-power adopted by the Committee of 1885 was the same as that used in the reports of the boiler-tests made at the Centennial Exhibition in 1876. The Committee of 1885 reported in favor of this standard in language of which the following is an extract :

Your Committee, after due consideration, has determined to accept the Centennial standard, and to recommend that in all standard trials the commercial horse-power be taken as an evaporation of 30 pounds of water per hour from a feed-water temperature of 100 degrees Fahr. into steam at 70 pounds gauge-pressure, which shall be considered to be equal to $34\frac{1}{2}$ units of evaporation; that is, to $34\frac{1}{2}$ pounds of water evaporated from a feed-water temperature of 212 degrees Fahr. into steam at the same temperature. This standard is equal to 33,305 thermal units per hour.

The Committee of 1899 accepted the same standard, but reversed the order of two clauses in the statement, and slightly modified them, so as to read as follows :

The unit of commercial horse-power developed by a boiler shall be taken as $34\frac{1}{2}$ units of evaporation per hour; that is, $34\frac{1}{2}$ pounds of water evaporated per hour from a feed-water temperature of 212 degrees Fahr. into dry steam of the same temperature. This standard is equivalent to 33,317 British thermal units per hour. It is also practically equivalent to an evaporation of 30 pounds of water from a feed-water temperature of 100 degrees Fahr. into steam at 70 pounds gauge-pressure. †

* Trans. A. S. M. E., vols. vi. and xxi.

† According to the tables in Porter's Treatise on the Richards' Steam-engine Indicator, an evaporation of 30 pounds of water from 100 degrees Fahr. into steam

The Committee also indorsed the statement of the Committee of 1885 concerning the commercial rating of boilers, changing somewhat its wording, so as to read as follows :

A boiler rated at any stated capacity should develop that capacity when using the best coal ordinarily sold in the market where the boiler is located, when fired by an ordinary fireman, without forcing the fires, while exhibiting good economy ; and further, the boiler should develop at least one-third more than the stated capacity when using the same fuel and operated by the same fireman, the full draft being employed and the fires being crowded ; the available draft at the damper, unless otherwise understood, being not less than $\frac{1}{2}$ inch water-column.

Measures for Comparing the Duty of Boilers.—The measure of the efficiency of a boiler is the number of pounds of water evaporated per pound of combustible, the evaporation being reduced to the standard of “from and at 212°” ; that is, the equivalent evaporation from feed-water at a temperature of 212° F. into steam at the same temperature.

The measure of the capacity of a boiler is the number of pounds of water evaporated from and at 212° F. per hour, or it is the amount of “boiler horse-power” developed, a horse-power being defined as the evaporation of $34\frac{1}{2}$ lbs. of water per hour from and at 212°.

The measure of relative rapidity of steaming of boilers is the number of pounds of water evaporated from and at 212° per hour per square-foot of water-heating surface.

The measure of relative rapidity of combustion of fuel in boiler-furnaces is the number of pounds of coal burned per hour per square foot of grate surface.

Proportions of Grate and Heating Surface required for a given Commercial Horse-power.—(1 H. P. = 34.5 lbs. from and at 212° F.)

Average proportions for maximum economy for land boilers fired with good anthracite coal :

| | |
|--|--------------|
| Heating surface per horse-power..... | 11.5 sq. ft. |
| Grate “ “ “ | 1/3 “ |
| Ratio of heating to grate surface..... | 34.5 “ |
| Water evap'd from and at 212° per sq. ft. H. S. per hour | 3 lbs. |
| Combustible burned per H. P. per hour..... | 3 “ |

at 70 pounds pressure is equal to an evaporation of 34,488 pounds from and at 212 degrees ; and an evaporation of $34\frac{1}{2}$ pounds from and at 212 degrees Fahr. is equal to 30,010 pounds from 100 degrees Fahr. into steam at 70 pounds pressure.

The “unit of evaporation” being equivalent to 965.7 thermal units, the commercial horse power = $34.5 \times 965.7 = 33,317$ thermal units.

| | |
|--|----------|
| Coal with 1/6 refuse, lbs. per H. P. per hour..... | 3.6 lbs. |
| Combustible burned per sq. ft. grate per hour | 9 " |
| Coal with 1/6 refuse, lbs. per sq. ft. grate per hour..... | 10.8 " |
| Water evap'd from and at 212° per lb. combustible..... | 11.5 " |
| " " " " " " " " coal (1/6 refuse).. | 9.6 " |

Heating Surface.—For maximum economy with any kind of fuel a boiler should be proportioned so that at least one square foot of heating surface should be given for every 3 lbs. of water to be evaporated from and at 212° F. per hour. Still more liberal proportions are required if a portion of the heating surface has its efficiency reduced by: 1. Tendency of the heated gases to short-circuit; that is, to select passages of least resistance and flow through them with high velocity, to the neglect of other passages. 2. Deposition of soot from smoky fuel. 3. Incrustation. If the heating surfaces are clean, and the heated gases pass over them uniformly, little if any increase in economy can be obtained by increasing the heating surface beyond the proportion of 1 sq. ft. to every 3 lbs. of water to be evaporated, and with all conditions favorable but little decrease of economy will take place if the proportion is 1 sq. ft. to every 4 lbs. evaporated; but in order to provide for driving of the boiler beyond its rated capacity, and for possible decrease of efficiency due to the causes above named, it is better to adopt 1 sq. ft. to 3 lbs. evaporation per hour as the minimum standard proportion.

Where economy may be sacrificed to capacity, as where fuel is very cheap, it is customary to proportion the heating surface much less liberally. The following table shows approximately the relative results that may be expected with different rates of evaporation, with anthracite coal:

| | | | | | | | | | | |
|--|------|------|------|------|------|------|------|------|------|------|
| Lbs. water evaporated from and at 212° per sq. ft. heating surface per hour : | | | | | | | | | | |
| 2 | 2.5 | 3 | 3.5 | 4 | 5 | 6 | 7 | 8 | 9 | 10 |
| Sq. ft. heating surface required per horse-power : | | | | | | | | | | |
| 17.3 | 13.8 | 11.5 | 9.8 | 8.6 | 6.8 | 5.8 | 4.9 | 4.3 | 3.8 | 3.5 |
| Ratio of heating to grate surface if ½ sq. ft. of G. S. is required per H.P. : | | | | | | | | | | |
| 52 | 41.4 | 34.5 | 29.4 | 25.8 | 20.4 | 17.4 | 13.7 | 12.9 | 11.4 | 10.5 |
| Probable relative economy : | | | | | | | | | | |
| 100 | 100 | 99 | 98 | 95 | 92 | 88 | 84 | 80 | 75 | 70 |
| Probable temperature of chimney-gases, degrees F. : | | | | | | | | | | |
| 450 | 450 | 470 | 490 | 520 | 580 | 650 | 710 | 770 | 850 | 930 |

The relative economy will vary not only with the amount of heating surface per horse-power, but with the efficiency of that heating surface as regards its capacity for transfer of heat from the heated gases

to the water, which will depend on its freedom from soot and incrustation, and upon the circulation of the water and the heated gases.

With bituminous coal the efficiency will largely depend upon the thoroughness with which the combustion is effected in the furnace.

The efficiency with any kind of fuel will greatly depend upon the amount of air supplied to the furnace in excess of that required to support combustion. With strong draft and thin fires this excess may be very great, causing a serious loss of economy. This subject has been fully discussed in Chapter IX.

Measurement of Heating Surface.—Authorities are not agreed as to the methods of measuring the heating surface of steam-boilers. The usual rule is to consider as heating surface all the surfaces that are surrounded by water on one side and by flame or heated gases on the other.

It has hitherto been the common practice of boiler-makers to consider all surfaces as heating surfaces which transmit heat from the flame or gases to the water, making no allowance for different degrees of effectiveness; also, to use the external instead of the internal diameter of tubes, for greater convenience in calculation, the external diameter of boiler-tubes usually being made in even inches or half inches. This method, however, is inaccurate in the case of a fire-tube boiler, for the true heating surface of a fire-tube is the side exposed to the hot gases, i.e., the inner surface. The resistance to the passage of heat from the hot gases on one side of a tube or plate to the water on the other consists almost entirely of the resistance to the passage of the heat from the gases into the metal, the resistance of the metal itself and that of the wetted surface being practically nothing.*

RULE for finding the heating surface of horizontal tubular boilers: Take the dimensions in inches. Multiply two-thirds of the circumference of the shell by its length; multiply the sum of the circumferences of all the tubes by their common length; to the sum of these products add two-thirds of the area of both tube-sheets; from this sum subtract twice the combined area of all the tubes; divide the remainder by 144 to obtain the result in square feet.

RULE for finding the heating surface of vertical tubular boilers: Multiply the circumference of the fire-box (in inches) by its height above the grate; multiply the combined circumference of all the tubes by their length, and to these two products add the area of the lower

* See paper by C. W. Baker, Trans. A. S. M. E., vol. xix. p. 571.

tube-sheet; from this sum subtract the area of all the tubes, and divide by 144: the quotient is the number of square feet of heating surface.

RULE for finding the square feet of heating surface in tubes: Multiply the number of tubes by the diameter of a tube in inches, by its length in feet, and by .2618.

Horse-power, Builder's Rating. Heating Surface per Horse-power.

—It is a general practice among builders to furnish from 10 to 12 square feet of heating surface per horse-power, but as the practice is not uniform, bids and contracts should always specify the amount of heating surface to be furnished. Not less than one-third square foot of grate surface should ordinarily be furnished per horse-power in order that the boiler may be able to develop from 30 to 50 per cent more than its stated power for short periods in emergencies; but a smaller proportion may be sufficient with free-burning coal and strong draft. See "Grate Surface," below.

Engineering News, July 5, 1894, gives the following rough-and-ready rule for finding approximately the commercial horse-power of tubular or water-tube boilers: Number of tubes \times their length in feet \times their nominal diameter in inches $\div 50 = nLd \div 50$. The number of square feet of surface in the tubes is $\frac{n\pi dL}{12} = \frac{nLd}{3.82}$, and the horse-power at 12 square feet of surface of tubes per horse-power, not counting the shell, $= nLd \div 45.8$. If 15 square feet of surface of tubes be taken, it is $nLd \div 57.3$. Making allowance for the heating surface in the shell will reduce the divisor to about 50.

Horse-power of Marine and Locomotive Boilers.—The term horse-power is not generally used in connection with boilers in marine practice, or with locomotives. The boilers are designed to suit the engines, and are rated by extent of grate and heating surface only.

Grate Surface.—The amount of grate surface required per horse-power, and the proper ratio of heating surface to grate surface are extremely variable, depending chiefly upon the character of the coal and upon the rate of draft. With good coal, low in ash, approximately equal results may be obtained with large grate surface and light draft and with small grate surface and strong draft, the total amount of coal burned per hour being the same in both cases. With good bituminous coal, like Pittsburg, low in ash, the best results apparently are obtained with strong draft and high rates of combustion, provided the grate surfaces are cut down so that the total coal burned per hour is not too great for the capacity of the heating surface to absorb the heat produced.

With coals high in ash, especially if the ash is easily fusible, tending to choke the grates, large grate surface and a slow rate of combustion are required, unless means, such as shaking-grates, are provided to get rid of the ash as fast as it is made.

The amount of grate surface required per horse-power under various conditions may be estimated from the following table:

| | Lbs. Water from and at 212° per lb. Coal. | Lbs. Coal per H.P. per hour. | Pounds of Coal burned per square foot of Grate per hour. | | | | | | | | | |
|--------------------------|---|------------------------------|--|------|-----|-----|-----|-----|-----|-----|-----|-----|
| | | | 8 | 10 | 12 | 15 | 20 | 25 | 30 | 35 | 40 | |
| | | | Sq. Ft. Grate per H.P. | | | | | | | | | |
| Good coal and boiler, | 10 | 3.45 | .43 | .35 | .28 | .23 | .17 | .14 | .11 | .10 | .09 | |
| | | | 9 | 3.83 | .48 | .38 | .32 | .25 | .19 | .15 | .13 | .11 |
| Fair coal or boiler, | 8.61 | 4 | .50 | .40 | .33 | .26 | .20 | .16 | .13 | .12 | .10 | |
| | | | 7 | 4.31 | .54 | .43 | .36 | .29 | .22 | .17 | .14 | .13 |
| Poor coal or boiler, | 6.9 | 5 | .62 | .49 | .41 | .33 | .24 | .20 | .17 | .14 | .12 | |
| | | | 6 | 5.75 | .63 | .50 | .42 | .34 | .25 | .20 | .17 | .15 |
| Lignite and poor boiler, | 5 | 6.9 | .72 | .58 | .48 | .38 | .29 | .23 | .19 | .17 | .14 | |
| | | | 3.45 | 10 | .86 | .69 | .58 | .46 | .35 | .28 | .23 | .22 |
| | | | 1.25 | 1.00 | .83 | .67 | .50 | .40 | .33 | .29 | .25 | |

In designing a boiler for a given set of conditions, the grate surface should be made as liberal as possible, say sufficient for a rate of combustion of 10 lbs. per square foot of grate for anthracite, and 15 lbs. per square foot for bituminous coal, and in practice a portion of the grate surface may be bricked over if it is found that the draft, fuel, or other conditions render it advisable. In earlier times, when plain cylinder and two-flue boilers were in common use, it was customary to have a ratio of say 1 to 20, or 1 to 25, of grate heating surface. With very slow rates of combustion these proportions gave a fair degree of economy, but as boilers were driven faster, the economy fell off, and the loss of heat in the chimney-gases became excessive. This was corrected by the introduction of horizontal tubular boilers, in which the grate surface remaining the same, the extent of heating surface was increased until the ratio of grate to heating surface became 1 to 30. When water-tube boilers came largely into use it was found that the highest economy could be obtained with a ratio of 1 to 40 or 1 to 50. In recent years it has become quite common to pile up heating surface on a given area of grate, so that ratios of 1 to 60 are not infrequent. The evident advantage of such a ratio is that it enables a given horse-power to be built on a smaller ground-space than before, and by using tubes 18

feet long instead of 14, and piling tubes 10 or 15 rows high instead of 7 or 8, the first cost of a given horse-power is reduced. With anthracite egg coal, or with semi-bituminous coal low in ash, and with a strong draft, no disadvantage results from this method of construction; but with poorer coals, such as pea, buckwheat, and rice, and the bituminous coals of Western States, high in moisture, sulphur, and ash, there is a most serious disadvantage, namely, that of cutting down the working capacity of the boiler. A water-tube boiler with 2300 sq. ft. of heating surface and 46 sq. ft. of grate surface, having a ratio of 50 to 1, and rated at 200 H.P., may easily be driven with semi-bituminous or with Pittsburg coal, the draft being sufficient, to over 300 H.P., while with a poor grade of Illinois coal, or with buckwheat anthracite, it would be difficult to drive the boiler up to its rating. With ordinary grates and hand-firing with such coals, increasing the draft beyond a certain amount does not increase the coal-burning capacity, for rapid driving only causes the ash to accumulate more rapidly and to fuse into clinker, choking the draft through the coal and necessitating frequent cleaning. Shaking-grates may remedy the trouble to some extent, but the best remedy is an increase of the area of grate surface and a slower rate of combustion.

In drawing specifications for bids upon boilers it is quite as essential that the extent of grate surface should be specified as the extent of heating surface, especially when the coal to be used is of a poor quality. When two competing boiler-makers offer boilers of the same type and the same extent of heating surface, that one should be preferred, other things being equal, which has the larger grate surface. It may be driven to a greater capacity than the other, to meet emergencies, or it will give the same capacity with a poor grade of coal that the other will give with better coal. Too large a grate surface is an evil that may easily be remedied, by shortening the grates, but too small grate surface necessitates the use of the higher priced coals, entails more labor in handling fires, more frequent cleaning of fires, and consequent loss of economy.

Boilers are usually sold on the basis of rated horse-power, from 10 to 12 square feet of heating surface being taken as equivalent to a horse-power, but of two boilers, each of the same rating on this basis, but one having say 40 sq. ft. of grate and the other 60, the latter, with a poor grade of coal, will develop almost 50 per cent greater power than the former and will give almost the same economy. With

a free-burning coal, low in ash, and ample draft, the boiler with 40 sq. ft. of grate may develop 30 or 40 per cent above its rating, and the one with 60 sq. ft. nearly 100 per cent above rating, but in this case, the boiler with large grate surface will show a great loss of economy, because it is overdriven.

Proportions of Areas of Flues and other Gas-passages.—Rules are sometimes given making the area of gas-passages bear a certain ratio to the area of the grate surface; thus a common rule for horizontal tubular boilers is to make the area over the bridge wall $\frac{1}{4}$ of the grate surface, the flue area $\frac{1}{8}$, and chimney area $\frac{1}{8}$.

For average conditions with anthracite coal and moderate draft, say a rate of combustion of 12 lbs. coal per square foot of grate per hour, and a ratio of heating to grate surface of 30 to 1, this rule is as good as any, but it is evident that if the draft were increased so as to cause a rate of combustion of 24 lbs., requiring the grate surface to be cut down to a ratio of 60 to 1, the areas of gas-passages should not be reduced in proportion. The amount of coal burned per hour being the same under the changed conditions, and there being no reason why the gases should travel at a higher velocity, the actual areas of the passages should remain as before, but the ratio of the area to the grate surface would in that case be doubled.

Mr. Barrus states that the highest efficiency with anthracite coal is obtained when the tube area is $\frac{1}{8}$ to $\frac{1}{10}$ of the grate surface, and with bituminous coal when it is $\frac{1}{8}$ to $\frac{1}{7}$, for the conditions of medium rates of combustion, such as 10 to 12 lbs. per square foot of grate per hour, and 12 square feet of heating surface allowed to the horse-power.

The tube area should be made large enough not to choke the draft, and so lessen the capacity of the boiler; if made too large the gases are apt to select the passages of least resistance and escape from them at a high velocity and high temperature.

This condition is very commonly found in horizontal tubular boilers where the gases go chiefly through the upper rows of tubes; sometimes also in vertical tubular boilers, where the gases are apt to pass most rapidly through the tubes nearest to the centre. It may to some extent be remedied by placing retarders in those tubes in which the gases travel the quickest.

Air-passages Through Grate-bars.—The usual practice is to make the air-opening equal to 30% to 50% of the area of the grate; the larger the better, to avoid stoppage of the air-supply by clinker; but,

with coal free from clinker, much smaller air-space may be used without detriment. See "Grate-bars," in Chap. VII. page 151.

Performance of Boilers.—The performance of a steam-boiler comprises both its capacity for generating steam and its economy of fuel. Capacity depends upon size, both of grate surface and of heating surface, upon the kind of coal burned, upon the draft, and also upon the economy. Economy of fuel depends upon the completeness with which the coal is burned in the furnace, upon the proper regulation of the air-supply to the amount of coal burned, and upon the thoroughness with which the boiler absorbs the heat generated in the furnace. The absorption of heat depends upon the extent of heating surface in relation to the amount of coal burned or of water evaporated, upon the arrangement of the gas-passages, and upon the cleanness of the surfaces. The capacity of a boiler may increase with increase of economy when this is due to more thorough combustion of the coal or to better regulation of the air-supply, or it may increase at the expense of economy when the increased capacity is due to overdriving, causing an increased loss of heat in the chimney-gases. The relation of capacity to economy is therefore a complex one, depending on many variable conditions.

Many attempts have been made to construct a formula expressing the relation between capacity, rate of driving, or evaporation per square foot of heating surface, to the economy, or evaporation per pound of combustible; but none of them can be considered satisfactory, since they make the economy depend only on the rate of driving (a few so-called "constants," however, being introduced in some of them for different classes of boilers, kinds of fuel, or kind of draft), and fail to take into consideration the numerous other conditions upon which economy depends. Such formulæ are Rankine's, Clark's, Emery's, Isherwood's, Carpenter's, and Hale's. A discussion of them all may be found in Mr. R. S. Hale's paper on "Efficiency of Boiler Heating Surface," in *Trans. Am. Soc. M. E.*, vol. xviii. p. 328. Mr. Hale's formula takes into account the effect of radiation, which reduces the economy considerably when the rate of driving is less than 3 lbs. per square foot of heating surface per hour. The author's formula, in which the efficiency is shown to be a function of six different variables, is given in the chapter on Efficiency of Heating Surface. (Formulas 13, 14, and 15, page 219.)

Range of Results Obtained from Anthracite Coal.—Selecting the

highest results obtained at different rates of driving with anthracite coal in the Centennial tests in 1876, and the highest results with anthracite reported by Mr. Barrus in his book on Boiler Tests, the two curves in the diagram, Fig. 107, have been plotted, showing the maximum results which may be expected with anthracite coal, the first

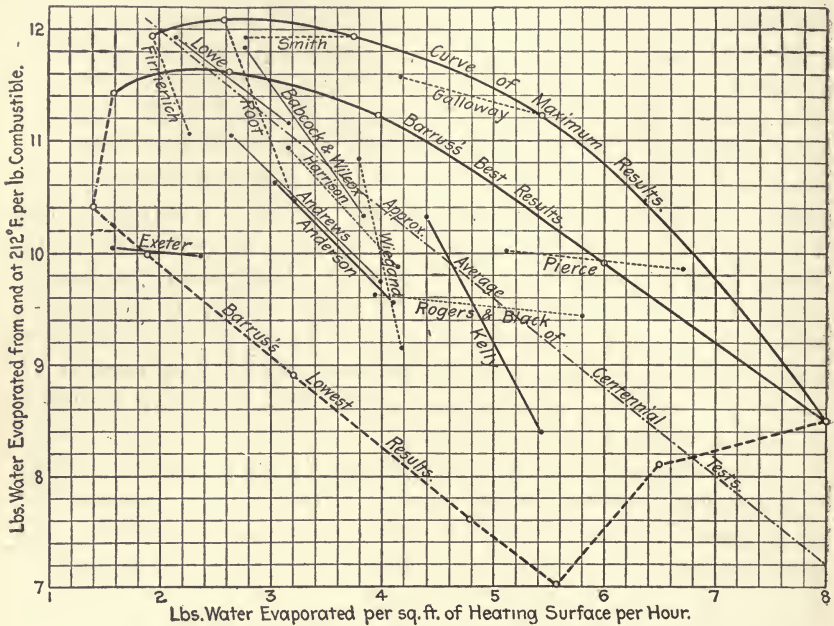

FIG. 107.—RESULTS OF TESTS WITH ANTHRACITE COAL.

under exceptional conditions, such as obtained in the Centennial tests, and the second under the best conditions of ordinary practice (Trans. Am. Soc. M. E., vol. xviii. p. 354). From these curves the following figures are obtained:

| | Lbs. water evaporated from and at 212° per sq. ft. heating surface per hour : | | | | | | | | | |
|------------------|---|-------|-------|------|-------|-------|-------|------|-----|-----|
| | 2 | 2.5 | 3 | 3.5 | 4 | 4.5 | 5 | 6 | 7 | 8 |
| Centennial..... | 12. | 12.1 | 12.1 | 12. | 11.85 | 11.7 | 11.45 | 10.8 | 9.8 | 8.5 |
| Barrus..... | 11.65 | 11.65 | 11.55 | 11.4 | 11.2 | 10.95 | 10.6 | 9.9 | 9.2 | 8.5 |
| Avg. Cent'l..... | 12.0 | 11.6 | 11.2 | 10.8 | 10.4 | 10.0 | 9.6 | 8.8 | 8.0 | 7.2 |

The figures in the last line are taken from a straight line drawn as nearly as possible through the average of the plotting of all the Centennial tests. The poorest results are far below these figures. It is evident that no formula can be constructed that will express the rela-

tion of economy to rate of driving as well as do the three lines of figures given above.

The following table gives the principal results obtained in the economy trials at the Centennial Exhibition, together with the capacity and economy figures of the capacity trials for comparison: *

| Name of Boiler. | Economy Tests. | | | | | | | | | | Capacity Tests. | | | |
|--------------------|---|---|--------------------------|---|---|------------------------|--------------------|------------------------|--------------|--------------|---|---|--|--|
| | Ratio Water-heating Surface to Grate-surface. | Coal Burned per sq. ft. Grate per Hour. | Per cent Ash and Refuse. | Water Evap. from and at 212° per sq. ft. H.S. per Hour. | Water Evap. from and at 212° p. lb. Comb'ble cor. for Quality of Steam. | Temperature in Uptake. | Moisture in Steam. | Superheating of Steam. | Horse-power. | Horse-power. | Water Evap. from and at 212° per lb. Combustible. | Water Evap. from and at 212° per sq. ft. H.S. per Hour. | | |
| | lbs. | p.ct. | lbs. | lbs. | deg. | p.ct. | deg. | H.P. | H.P. | lbs. | lbs. | | | |
| Root..... | 34.6 | 9.1 | 10.4 | 2.59 | 12,094 | 393 | | 41.4 | 119.8 | 148.6 | 10,441 | 3.21 | | |
| Firmenich..... | 64.3 | 12.0 | 10.4 | 1.93 | 11,988 | 415 | | 32.6 | 57.8 | 68.4 | 11,064 | 2.29 | | |
| Lowe..... | 30.6 | 6.8 | 11.3 | 2.15 | 11,923 | 333 | | 9.4 | 47.0 | 69.3 | 11,163 | 3.17 | | |
| Smith..... | 45.8 | 12.1 | 11.1 | 2.79 | 11,906 | 411 | 1.3 | | 99.8 | 125.0 | 11,925 | 3.74 | | |
| Babcock & Wilcox. | 37.7 | 10.0 | 11.0 | 2.79 | 11,822 | 296 | 2.7 | | 135.6 | 186.6 | 10,330 | 3.84 | | |
| Galloway..... | 23.7 | 9.6 | 11.1 | 4.18 | 11,583 | 303 | | 1.4 | 103.3 | 133.8 | 11,216 | 5.41 | | |
| do semi-bit. coal. | 23.7 | 7.9 | 8.8 | 3.68 | 12,125 | 325 | 0.8 | | 90.9 | 125.1 | 11,609 | 5.06 | | |
| Andrews..... | 15.6 | 8.0 | 10.3 | 2.67 | 11,039 | 420 | | 71.7 | 42.6 | 58.7 | 9,745 | 4.00 | | |
| Harrison..... | 37.3 | 12.4 | 8.5 | 3.16 | 10,930 | 517 | 0.9 | | 82.4 | 108.4 | 9,889 | 4.15 | | |
| Wiegand..... | 30.7 | 12.3 | 9.5 | 3.80 | 10,834 | 524 | | 20.5 | 147.5 | 162.8 | 9,145 | 4.19 | | |
| Anderson..... | 17.5 | 9.7 | 9.3 | 3.03 | 10,618 | 417 | | 15.7 | 98.0 | 132.8 | 9,568 | 4.11 | | |
| Kelly..... | 20.9 | 10.8 | 9.0 | 4.40 | 10,312 | | 5.6 | | 81.0 | 99.9 | 8,397 | 5.43 | | |
| Exeter..... | 33.5 | 9.3 | 11.4 | 1.59 | 10,041 | 430 | 4.2 | | 72.1 | 108.0 | 9,974 | 2.38 | | |
| Pierce..... | 14.0 | 8.0 | 11.0 | 5.11 | 10,021 | 374 | 5.2 | | 51.7 | 67.8 | 9,865 | 6.70 | | |
| Rogers & Black.... | 19.0 | 8.6 | 9.9 | 3.94 | 9,613 | 572 | 2.1 | | 45.7 | 67.2 | 9,429 | 5.80 | | |
| Averages..... | | | | 3.19 | 11,123 | | | | 85.0 | 110.8 | 10,251 | 4.23 | | |

The comparison of the economy and capacity trials shows that an average increase in capacity of 30 per cent was attended by a decrease in economy of 8 per cent, but the relation of economy to rate of driving varied greatly in the different boilers. In the Kelly boiler an increase in capacity of 23 per cent was attended by a decrease in economy of over 18 per cent, while the Smith boiler, with an increase of 25 per cent in capacity showed a slight increase in economy. The results are plotted on the diagram, Fig. 107.

For semi-bituminous and bituminous coals the relation of economy to the rate of driving follows the same general law that it does with anthracite, i.e., that beyond a rate of evaporation of 3 or 4 lbs. per sq. ft. of heating surface per hour there is a decrease of economy, but the figures obtained in different tests will show a wider range between maximum and average results on account of the fact that it is more difficult with bituminous than with anthracite coal to secure complete combustion in the furnace.

* Reports and Awards Group XX, International Exhibition, Phila., 1876; also, Clark on the Steam-engine, vol. i. p. 253.

CHAPTER XII.

“POINTS” OF A GOOD BOILER.

THE boilers which have been described and illustrated in chapter X include all the types which are extensively used in land practice in the United States. They offer enough variety to satisfy the ideas or prejudices of all classes of purchasers. Boilers of each of these types, more or less modified, with one or two exceptions, are made by more than one builder, the fundamental patents on all of them having expired, and competition between rival builders is so intense that any kind of boiler may now be purchased at a slight advance over its cost to the builder. The factory cost has also been greatly reduced by the introduction of improved machinery and by the reduced prices of raw material. It would be out of place here to recommend any one type of boiler as superior to any other, but some ideas may be given in regard to the good and bad “points” of boilers in general, which may be of assistance to an intending purchaser or an engineer who is confused by the conflicting statements of rival builders or salesmen.

Selecting a New Type of Boiler.—The problem of selecting a new form of boiler to replace one of an old type is, to the average steam-user, one of considerable difficulty on account of the vast variety of styles that are now offered in the market, and the conflicting statements of rival builders. The evolution of the steam-boiler has now reached a period of extreme confusion, in which diversity of form is the leading feature. In other lines of engineering we have reached standard types which are accepted the world over as being the best available. Thus there has been no radical change in the type of locomotive for fifty years. The Scotch boiler is in almost universal use for marine purposes. For transatlantic steamships and for high-duty pumping-engines, scarcely any other kind of an engine than a vertical triple-expansion engine would be thought of. The Corliss engine has

been accepted as the standard high-class engine for land purposes for forty years. But in land boilers we not only have the variety of styles shown in the table already given of percentages of different styles used in several countries of Europe, but in the United States there is a continual procession of new forms through the Patent Office, of which enough find builders and advertisers to continually add to the existing confusion.

The claims made for these new forms of boilers are generally in inverse ratio to their merits. The following are extracts from advertisements in a single issue of one trade journal in February, 1897:

No. 1.—We guarantee you a saving of from 10 to 25 per cent with equal horse-power, or an increase of horse-power of from 10 to 25 per cent with the same fuel if you use the —— steam-generator.

No. 2.—The circulation positively prevents scale.

No. 3.—The best boiler ever built, combining many points of merit not contained in any other boiler. Will evaporate the largest amount of water per pound of coal.

No. 4.—Is an efficiency of 30 per cent above all others of interest to you? Send for particulars.

No. 5.—An evaporation of 14.66 lbs. of water from and at 212° per pound of combustible.

It is worthy of note that none of the large boiler companies, who have reputations established for many years, advertise in this manner, and of the boilers which are advertised in the above extracts, not one has any exceptional merit which would warrant its being selected in preference to the best of the older and better-known boilers. It is simply impossible that any one of these new boilers can, in an accurate test, evaporate 14.66 lbs. of water, from and at 212° , per lb. of combustible (if coal is used as fuel, it might do this and more with petroleum), or that any one of them can show 10 per cent better economy than a well-proportioned boiler of older form, or that any kind of circulation can keep a boiler free from scale or from deposits of solid matter if the water contains scale-forming material.

The moral is this: Do not place any reliance in the advertisement of a boiler which claims that it is superior to all other boilers in fuel-economy or in prevention of scale. The largest and most successful boiler concerns, who make as good boilers as have ever been made, or are likely to be made for some years to come, do not advertise in this way.

Economy of Fuel.—Let it be assumed that all the boilers offered

for choice are built by makers of good repute, that the quality of material and workmanship is beyond question, and that the dimensions and arrangement of all the parts are so chosen that they are all equally safe to resist a bursting pressure. These essentials of good boiler construction may be secured with any of the types described, by having the specifications properly drawn and by rigid inspection of the material and workmanship. The economy of fuel which may be obtained with any boiler does not depend upon the type of boiler, but upon its proportions, such as the amount of heating and grate-surface furnished for a given horse-power, upon the kind of furnace used, and upon the arrangement of the gas-passages so as to cause the gas to give up as large a percentage of its heat as possible to the heating surface. These are matters of engineering design with any type of boiler, and any boiler may have them so arranged as to cause it to give as high an economy of fuel as is possible with any other boiler. Questions that arise under this head in regard to any boiler are: 1. Is the grate-surface sufficient for burning the maximum quantity of coal expected to be used at any time, taking into consideration the available draft, the quality of the coal, its percentage of ash, whether or not the ash tends to run into clinker, and the facilities, such as shaking grates, for getting rid of the ash or clinker? 2. Is the furnace of a kind adapted to burn the particular kind of coal used? 3. Is the heating surface of extent sufficient to absorb so much of the heat generated that the gases escaping into the chimney shall be reasonably low in temperature, say not over 400° F. with anthracite and 500° F. with bituminous coal? 4. Are the gas-passages so designed and arranged as to compel the gas to traverse at a uniform rate the whole of the heating surface, not being so large at any point as to allow the gas to find a path of least resistance or be short-circuited, or, on the other hand, so contracted at any point as to cause an obstruction to the draft?

These questions being settled in favor of any given boiler, and they may be answered favorably for boilers of any of the modern types already described, provided the furnaces and boilers are properly designed, the relative merits of the different types may now be considered with reference to their danger of explosion; their probable durability; the character and extent of repairs that may be needed from time to time, and the difficulty, delay, and expense that these may entail; the accessibility of every part of the boiler to inspection, internal and external; the facility for removal of mud and scale from every portion of the inner surface, and of dust and soot from the ex-

terior; the water- and steam-capacity; the steadiness of water-level; and the arrangements for securing dry steam.)

Each one of the points above referred to should be considered carefully by the intending purchaser of any type of boiler with which he is not familiar by experience. The several points may be considered more in detail.

Danger of Explosion.—All boilers may be exploded by over-pressure, such as might be caused by the combination of an inattentive fireman and an inoperative safety-valve, or by corrosion weakening the boiler to such an extent as to make it unable to resist the regular working pressure; but some boilers are much more liable to explosion than others. In considering the probability of explosion of any boiler of recent design, it is well to study it to discover whether or not it has any of the features which are known to be dangerous in the plain cylinder, the horizontal tubular, the vertical tubular and the locomotive boilers. (The plain cylinder boiler is liable to explosion from strains induced by its method of suspension, and by changes of temperature. Alternate expansion and contraction may produce a line of weakness in one of the rings, which may finally cause an explosion. A boiler should be so suspended that all its parts are free to change their position under changes of temperature without straining any part. The circulation of water in the boiler should be sufficient to keep all parts at nearly the same temperature. Cold feed-water should not be allowed to come in contact with the shell, as this will cause contraction and strain.) The horizontal tubular boiler, and all externally fired shell boilers, are liable to explosion from overheating of the shell, due to accumulation of mud, scale or grease on the portion of the shell lying directly over the fire; to a double thickness of iron, as at a lap-joint, together with some scale, over the fire; or to low water uncovering and exposing an unwetted part of the shell directly to the hot gases. (Vertical tubular boilers are liable to explosion from deposits of mud, scale or grease upon the lower tube-sheet, and from low water allowing the upper part of the tubes to get hot and cease to act as stays to the upper tube-sheet.) Locomotive boilers may explode from deposits on the crown-sheet, from low water exposing the dry crown-sheet to the hot gases, and from corrosion of the stay-bolts. Double-cylinder boilers, such as the French elephant boiler, and the boilers used at some American blast-furnaces, have exploded on account of the formation of a "steam-pocket" on the upper portion of the lower cylinder, the steam being prevented from escaping by

the lap-joint of one of the rings, thus making a layer of steam about $\frac{1}{4}$ inch thick against the shell which was directly exposed to the hot gases.

The above mentioned are only a few of the causes of explosions, but they are the principal ones that are due to features of design. These features should be looked for in any new style of boiler, and if they are found they should be considered elements of danger. Such questions as the following may be asked: Is the method of suspension of the boiler such as to allow its parts to be free to move under changes of temperature? Is the circulation such as to keep all parts at practically the same temperature? Is there a shell with riveted seams exposed to the fire? Is there a shell exposed to the fire which may at any time be uncovered by water or be covered with scale? Is there a crown-sheet on which scale may lodge? Are there sufficient facilities for the removal of scale? Are there vertical or inclined tubes acting as stays to an upper sheet, the upper part of which tubes may become overheated in case of low water? Are there any stayed sheets, the stays of which are liable to become corroded? Is there any chance for a steam-pocket to be formed on a sheet which is exposed to the fire?

In addition to the above-mentioned features of design, which are elements of danger, all boilers, as already stated, are liable to explosion due to corrosion. Internal corrosion is usually due to acid feed-water, or to very pure feed-water containing dissolved air, and all boilers are equally liable to it. External corrosion, however, is more liable to take place in some designs of boilers than in others, and in some locations rather than in others. If any portion of a boiler is in a cold and damp place, it is liable to rust out. For this reason the mud-drums of many modern forms of boilers are made of cast iron, which resists rusting better than either wrought iron or steel. If any part of a boiler, other than a part made of cast iron, is liable to be exposed to a cold and damp atmosphere, or covered with damp soot or ashes, or exposed to drip from rain or from leaky pipes, and especially if such part is hidden by brickwork or otherwise so that it cannot be inspected, that part is an element of danger.

Durability.—The question of durability is partly covered by that of danger of explosion, which has already been discussed, but it also is related to the question of incrustation and scale. The plates and tubes of a boiler may be destroyed by internal or external corrosion, but they may also be burned out. It may be regarded as impossible

to burn a plate or tube of iron or steel, no matter how high the temperature of the flame, provided one side of the metal is covered with water. If a steam-pocket is formed, so that the water does not touch the metal, or if there is a layer of grease or hard scale, then the plate or tube may be burned. In a water-tube which is horizontal, or nearly so, and in which the circulation of water is defective, it is possible to form a mass of steam which will drive the water away from the metal, and thus allow the tube to burn out. In considering the probable durability of a boiler, we may ask the same questions as those that have been asked concerning danger of explosion. There are, however, many chances of burning out a minor part of a boiler without serious danger, to one chance of a disastrous explosion. Thus the tubes of a water-tube boiler, if allowed to become thickly covered with scale, might be burned out without causing any further destruction than the rupture of a single tube. A new type of boiler should be questioned in regard to the likelihood of frequent small repairs being necessary, and as well in regard to its liability to complete destruction. We may ask: Is the circulation through all parts of the boiler such that the water cannot be driven out of any tube or from any portion of a plate, so as to form a steam-pocket exposed to high temperature? Are there proper facilities for removing the scale from every portion of the plates and tubes?

Repairs.—The questions of durability and of repairs are, in some respects, related to each other. The more infrequent and the less extensive the repairs, the greater the durability. The tubes of a boiler, where corroded or burnt out, may be replaced, and made as good as new. The shell, when it springs a leak, may be patched, and is then likely to be far from as good as new. When the shell corrodes badly it must be replaced, and to replace the shell is the same as getting a new boiler. Herein is the advantage of the sectional water-tube boilers. The sections, or parts of a section, may be renewed easily, and made good as new, while the shell, being far removed from the fire and easily kept dry externally, is not liable either to burning out or external corrosion. In considering the merits of a new style of boiler, with reference to repairs, we may ask what parts of the boiler are most likely to give out and need to be repaired or replaced? Are these repairs easily effected; how long will they require; and after they are made is the boiler as good as new? If a new style of boiler made up of special parts not procurable except from its builder, the

question may be asked : How long is the builder likely to remain in business and be able to furnish these special parts ?

Facility for Removal of Scale and for Inspection.—These questions have already been discussed to some extent under the head of durability. Some water-tube boilers, now dead and gone, were some years ago put on the market, which had no facilities for the removal of scale. It was claimed by their promoters that they did not need any, because their circulation was so rapid. Every few years boilers of these types are re-invented, and the same claim is made for them, that their rapid circulation prevents the formation of scale. The fact is that if there is scale-forming material in the water it will be deposited when the water is evaporated, and no amount or kind of circulation will keep it from accumulating on every part of the boiler and in every kind of tubes, vertical, horizontal, and inclined. The nearly vertical circulating tubes of a water-tube boiler, in which the circulation is nine times as fast as the average circulation in the inclined tubes, sometimes have been found nearly full of scale ; that is, a 4-inch tube had an opening in it of less than 1 inch diameter. This was due to carelessness in blowing off the boiler, or exceptionally bad feed-water, or both. If circulation would prevent scaling at all, it would prevent it here.

Water- and Steam-capacity.—It is claimed for some forms of boilers that they are better than others because they have a larger water- or steam-capacity. Great water-capacity is useful where the demands for steam are extremely fluctuating, as in a rolling-mill or a sugar-refinery, where it is desirable to store up heat in the water in the boilers during the periods of the least demand, to be given out during periods of greatest demand. Large water-capacity is objectionable in boilers for factories, usually, especially if they do not run at night, and the boilers are cooled down, because there is a large quantity of water to be heated before starting each morning. If “rapid steaming” or the ability to get up steam quickly from cold water, or to raise the pressure quickly, is desired, large water-capacity is a detriment. The advantage of large steam-capacity is usually overrated. It is useful to enable the steam to be drained from water before it escapes into the steam-pipe, but the same result can be effected by means of a dry pipe, as in locomotive and marine practice, in which the steam-space in the boiler is very small in proportion to the horsepower. Large steam-space in the boiler is of no importance for storing energy or equalizing the pressure during the stroke of an engine.

The water in the boiler is the place to store heat, and if the steam-pipe leading to an engine is of such small capacity that it reduces the pressure, the remedy is a steam-reservoir close to the engine or a large steam-pipe.

Steadiness of Water-level.—This requires either a large area of water-surface and volume of water, so that the level may be changed slowly by fluctuations in the demand for steam or in the delivery of the feed-pump, or else constant, and preferably automatic, regulation of the feed-water supply to suit the steam demand. A rapidly lowering water-level is apt to expose dry sheets or tubes to the action of the hot gases, and thus be a source of danger. A rapidly rising level may, before it is seen by the fireman, cause water to be carried over into the steam-pipe, and endanger the engine.

Large area of water-surface alone is not always sufficient to insure steadiness of water-level. Sudden fluctuations in the activity of the fire, such as take place when the gases from freshly-fired soft coal burst into flame, are apt to cause a sudden rise in the water-level. For this reason, boilers with horizontal water- and steam-drums, whether fire-tube or water-tube boilers, should preferably have drums not less than 30 ins. diameter, so that the water-level may be allowed to vary 5 or 6 ins. from its normal position without, on the one hand, endangering the burning out of the tubes, or, on the other, of making wet steam.

Dryness of Steam.—Most of the modern forms⁴ of both fire-tube and water-tube boilers give practically dry steam, that is, steam containing not over $1\frac{1}{2}$ % of moisture, when the water-level is not allowed to rise more than 5 or 6 ins. above its mean position, even when driven as much as 100 % beyond their rated capacity ; but boilers with vertical tubes, with small water-level area, are apt, sometimes, to have the water-level fluctuate violently, and they require to be provided with superheating surface and dry pipes, or steam separators, in order to insure dry steam. Alkaline feed-water is often a cause of “foaming,” causing wet steam.

Water-circulation.—Positive and complete circulation of the water in a boiler is important for two reasons : (1) To keep all parts of the boiler of a uniform temperature, and (2) to prevent the adhesion of steam-bubbles to the surface, which may cause overheating of the metal. It is claimed by some manufacturers that the rapid circulation of water in their boilers tends to make them more economical than others. We have as yet, however, to find any proof that increased

rapidity of circulation of water beyond that usually found in any boiler will give increased economy. We know that increased rate of flow of air over radiating surfaces increases the amount of heat transmitted through the surface, but this is because by the increased circulation cold air is continually brought in contact with the surface, making an increased difference of temperature on the two sides, which causes increased transmission. But by increasing the rapidity of circulation in a steam-boiler we cannot vary the difference of temperature to any appreciable extent, for the water and the steam in the boiler are at about the same temperature throughout. The ordinary or "Scotch" form of marine boiler shows an exception to the general rule of uniformity of temperature of water throughout the boiler, but the temperature above the level of the lower fire-tubes is practically uniform.

CHAPTER XIII.

BOILER TROUBLES AND BOILER-USERS' COMPLAINTS.

It is the experience of every large boiler-making concern that of all the boilers it sells, a certain proportion are, shortly after erection, complained of by the purchaser as being unsatisfactory. When such complaints are received, an expert in boiler-testing and management is usually sent to make an investigation, and, if possible, to remedy the trouble. In most cases he succeeds, after a great deal of difficulty, in satisfying the purchaser, either by improving the conditions of the running of the boiler or by showing that the boiler is not to blame for the trouble; but sometimes he fails, and the matter is finally adjusted by the boiler being taken out, by a reduction in the price, or by recourse to arbitration, or to a law-suit. In a law-suit the boiler-maker usually wins, for the reason that a boiler-maker, having had previous experience in such matters, is not apt to go to law unless he has a very strong case. The purchaser, of course, also thinks he has a strong case, but he is apt to be not well posted on the law of contracts, and his attorney is apt to be ignorant of the amount of evidence which the boiler-maker will bring forward on the trial, and therefore underrates the strength of the boiler-maker's side of the case. It is the object of this chapter to discuss, not the troubles and complaints concerning boilers in their relation to possible law-suits, but those that may be avoided or remedied by good engineering.

The complaints from boiler-users concerning new boilers may be divided into three general classes: 1, Low capacity; 2, Structural defects, such as leaks, burnt tubes and plates, etc.; 3, Poor economy. The last is not often a cause of complaint, because the great majority of boiler-users make no tests to determine economy, and therefore if their boilers should be deficient in economy, they are ignorant of it. But if a boiler does not give the amount of steam that is needed from it, or if it leaks, the trouble is apparent at once and complaint is made immediately.

The most common causes of complaints and troubles are the following:

1. Poor draft.
2. Insufficient grate surface.
3. Poor coal.
4. Furnace not adapted to kind of coal.
5. Bad setting of boiler.
6. Leaks of air through brickwork.
7. Improper firing.
8. Insufficient heating surface (boiler too small).
9. Bad water.

We will now discuss these causes of trouble, and their remedies, in the order named.

Poor Draft.—This is a relative term; what is poor draft for one set of conditions is ample draft for another. The proper force of draft for a given case, measured at a point between the damper in the flue and the boiler itself, may be as low as $\frac{1}{4}$ inch of water-column, and in another case over 1 inch may be required, depending on the type of boiler, on the area and the course of the draft-passage through the boiler, on the area of grate surface, on the style of grate-bars, and on the kind of coal. The immediate effect of poor draft is insufficient coal-burning capacity. The first test to be applied to discover whether or not the draft is insufficient is to weigh the coal burned in each hour during the period between two cleanings of the grates, and to compare the amounts burned each hour with the amount which a calculation shows should be burned to evaporate the desired amount of water. Thus, suppose that it is expected that the boiler should evaporate 3500 lbs. of water per hour, and the temperature of feed-water, the steam-pressure, and the quality of coal are such that 7 lbs. of water should be evaporated per pound of coal, then the coal-burning capacity should be not less than 500 lbs. during each hour between cleanings. If 200 lbs. is used in the first part of the test to build up the fire, and an equal amount is burned down at the close of the test, in order to have a thin bed of coal for cleaning, then a five-hours' record of coal fed between cleanings should show approximately 700, 500, 500, 500, and 300 lbs. If the record gave 600, 400, 400, 400, and 200 lbs. it would indicate insufficient draft for the kind of grate and the kind of coal. If, however, it should show 700, 500, 400, 300, 200 lbs., it would indicate that the draft itself was ample, but that the grates were being gradually choked by ashes and clinkers.

In the second case, in which the coal is burned steadily at the rate of 400 lbs. of coal per hour, when 500 lbs. is required, the remedy indicated is an increase of the draft. It will often happen that such remedy can easily be given by a slight change in the flue-connection between the boiler and chimney. Right-angled bends in this flue-connection are exceedingly common, and they frequently cut down the force of draft at the boiler to one-half of that in the chimney. Whenever possible they should be changed to long easy curves. When two or more adjoining boilers deliver their gases into one horizontal flue, the area of this flue should increase as it travels from the most distant boiler to the chimney, the connection from each boiler to the flue should be a curved one, and the flue itself should enter the chimney with an ascending curve. Before making the changes here suggested, the existing draft in the chimney, at various points in the flue, and at each boiler, should be tested by a U-tube draft-gauge. If there are no defects in the flue-connection, the next remedy to be applied is an increase in the height of the chimney. If this is not feasible, and a reference to a table of proportions of chimneys shows that the chimney has not sufficient area for the amount of coal to be burned, then a new chimney with larger area is required. In case it appears that the chimney is of sufficient area and its height cannot be increased, a remedy may be found in enlarging the area of grate-surface or in using a different kind of coal.

If the test of the coal-burning capacity shows a decreasing rate of burning, such as 700, 500, 400, 300, and 200 lbs. per hour, indicating a gradual choking of the grate by clinker, the most obvious remedy is the use of a shaking-grate, by which the accumulation of ashes and clinker may be prevented. Such a grate will sometimes increase the capacity of a boiler as much as 30 per cent, although its use may entail a loss of economy of 2 or 3 per cent due to the coal shaken into the ash-pit with the ashes. A change of coal from a clinkering to a non-clinkering variety will sometimes prove a sufficient remedy.

With a clinkering coal, increase of draft is sometimes of no benefit in increasing the capacity of a boiler, but rather the reverse; for when the fire is freshly cleaned, a strong draft with such coal causes at first a rapid combustion, resulting in high temperature and a fusing of the clinker, which soon obstructs the passage of air through the grates, checking the combustion. Enlargement of the grate surface and a slower rate of combustion per square foot of grate are then the proper remedies, and if these are impracticable, then shaking-grates should

be used. The tendency to form clinker may sometimes be lessened by blowing a little steam under the grate-bars, or by letting a little water run into the ash-pit. The evaporation of the water helps to cool the grate-bars.

Insufficient Grate Surface, and Poor Coal.—These two causes of trouble may be considered together as they are co-related. Insufficient grate surface for one grade of coal may be ample for another grade. By grade of coal here is meant its quality as regards amount of ash and kind of ash. If the percentage of ash in the coal is low, and it is low in iron and sulphur, which are the principal causes of clinker, a relatively small grate surface and a strong draft may be used, such, for instance, as to cause the burning of as much as 20 lbs. of anthracite, 25 or 30 lbs. of semi-bituminous, and 30 to 40 lbs. of bituminous coal per square foot of grate per hour; but if the ash is excessive, or if it forms clinker, then a large grate is needed, so that these rates of combustion may be reduced 30 to 50 per cent.

Furnace Not Adapted to Coal.—Thirty or forty years ago it used to be the custom to set boilers with the grate-bars near to the shell of the boiler, 12 to 15 ins. being a common distance, the idea being that there was a loss of radiant heat if the boiler was removed a greater distance from the grate. The idea was erroneous, as may be learned by considering the question “If the heat is lost, where does it go?” A pound of coal, in burning under a boiler, generates so many heat-units. A small fraction of them is lost through the side walls of the furnace. The heat radiated into the side walls is radiated back again to the fire, to the heating surface of the boiler, to the particles of carbon in the flame, and to gaseous products of combustion, and it finally all gets into the boiler except that which is carried out of the chimney or through the walls of the setting. With dry anthracite coal, which burns practically without flame, almost any kind of furnace is a good one, but a furnace in which the grate is 12 or 15 ins. from the boiler is entirely unsuited to the burning of bituminous coal. A distance of from 2 to 3 feet from the grate to the boiler is now common practice for bituminous coal. With very smoky coal, 4 feet is sometimes used; and 6 or 8 feet would be better.

A furnace for a steam-boiler is not adapted to the coal whenever the flame from the coal is extinguished by the comparatively cool surfaces of the boiler, and whenever it is not possible by skilful operation of the furnace to prevent smoke escaping from the chimney.

A smoky chimney is proof either of an improper furnace for the kind of coal or of unskilful firing, or both; usually of the former.

The loss of economy and the diminution of capacity of steam-boilers due to smoky chimneys is usually underestimated. It is stated that it has been found by experiment that the amount of soot actually present in smoke is less than one per cent of the weight of coal burned. Numerous experiments have shown also that when "smoke-consumers" are applied to a steam-boiler, while the smoke may be prevented, no gain in economy follows. This may be quite true, but the "smoke-consumers" referred to usually effect the smoke-prevention by means of an excessive supply of air, which involves waste of fuel, so that the failure to show a gain in economy is due to substituting the waste due to excessive air-supply for the waste due to imperfect combustion.

While it may be true also that the soot in smoke represents only one per cent of the fuel burned, this is not the only loss of fuel which attends the smoky chimney, for the smoke not only contains soot, but it may also contain invisible hydrocarbon gases distilled from the coal, and carbonic oxide produced in the furnace by imperfect combustion of the carbon.

Bad Setting of Boiler.—If the type of setting is one adapted to the kind of coal, it may still have errors of design or of construction which may lead to the loss of economy or of capacity, or of both. Examples of such errors are: (1) Boiler set too close to the grate. (2) Insufficient area through the flues, damper, or other passages for the gas. (3) Excessive area of gas-passages, so placed that the gases can find a path of least resistance along or across the heating surfaces, and thus be "short-circuited." The error of the boiler being set too close to the grate has already been discussed. Insufficient area of gas-passages acts to choke the draft and restrict the coal-burning capacity, just as do insufficient chimney area or height, and insufficient grate area. Whether or not the gas-passages are insufficient in area can usually be determined by inspection and comparison of their measurements with that of the chimney and grate. A draft-gauge should be applied at different points in the gas-passages, between the chimney and the furnace, in order to find whether there is any serious choke in the draft. This should be done when the fire is clean and burning brightly.

Whether or not the areas of the gas-passages are too large, or such as to allow of short-circuiting of the gases, is usually a rather difficult matter to determine. The error may be suspected to exist whenever

it is found by an evaporation-test that the boiler gives a lower result than should be expected under the conditions, and at the same time there is found a high temperature of the chimney-gases and a low rate of evaporation per square foot of heating surface. This same set of combined conditions, viz., low capacity, low economy, and high temperature of chimney-gases, may, however, be the result of imperfect combustion in the furnace and burning of the gases in the gas-passages between the furnace and the chimney. If there is no evidence of imperfect furnace-conditions and of the burning of gas in the passages, then short-circuiting of the gases is probably the cause of the observed results. After making the diagnosis of short-circuiting, another test of the boiler should be made, if sufficient draft is available, at a very much higher rate of combustion. If it is found that this test gives an increase of economy with no increase in the temperature of the chimney-gases, this would tend to prove that short-circuiting existed during the first test. The gases may short-circuit during the test at a low rate of driving and not during the other test because in the first test the volume of gases is relatively small, and in the second it is large, so that they completely fill the passages. The gas-passages may, therefore, be properly proportioned for a high rate of driving, but may be too large for a low rate.

Another kind of test which may be applied to determine whether or not there is short-circuiting of the gases, is the exploration of various portions of the gas-passages by an electric pyrometer, in order to discover if any portion is not swept by the current of hot gas. This instrument is of recent invention, and has not yet, to any great extent, been employed in boiler-testing, but its use is to be recommended in future scientific investigations of steam-boiler economy by boiler manufacturers and others. It is highly probable that many of the very low economic results sometimes obtained in boiler-tests, which are unexplained by the observed conditions, are due to this short-circuiting, the existence of which may be revealed by the electric pyrometer.

When short-circuiting of the gases is proved, the remedy is obviously to change the areas of the gas-passages, or to place baffle-plates or retarders in them, so as to partially obstruct those portions of the passages where the gases tend to travel with the greatest velocity, and compel them to travel at a uniform rate across or along the whole extent of heating surface.

Leaks of Air through Brickwork.—If there are any large air-leaks through the brickwork, they can usually be discovered by inspection.

There are two methods of making examinations for small leaks; first, passing the flame of a candle over all the joints of the brickwork and noting where it is drawn inwards by the draft; second, firing a few shovelful of smoky coal while the damper is shut. The smoke will then be driven out through any crevices that may exist. The existence of air-leaks in the brickwork beyond the furnace may be inferred from the results of a boiler-test, if these results show low economy together with low temperature of the chimney-gases and apparently good furnace-conditions, insuring complete combustion. If the coal is thoroughly burned in the furnace, then low economy is usually accompanied with high temperature of the chimney-gases, caused either by insufficient extent of heating surface or by short-circuiting of the gases, but if the temperature of the chimney-gases is low, economy also being low and furnace temperature high, this would indicate that the gases have been cooled by the cold air entering through leaks in the brickwork. Chemical analysis of the gases also furnishes a means of proving the existence of air-leaks. Samples of gas are taken simultaneously from a point near the furnace and from a point near the damper. If the latter sample shows on analysis a greater percentage of free oxygen than the former, it proves the admission of air into the gases between the points from which the two samples are taken.

If the supply of air to the coal in the furnace is sufficient to insure complete combustion, any additional supply, either in the furnace or through leaks in the brickwork into the gas-passages, tends to decrease the economy of the boiler. It cools the gases, decreasing the difference between the temperature of the gases and that of the water in the boiler, upon which difference the transmission of heat through the heating surface depends, and the excess of air-supply finally escapes at the temperature of the chimney-gases, thus causing a direct loss of heat. If, however, the supply of air in the furnace is insufficient to thoroughly burn the coal, a slight leak of air through the brickwork may be of actual benefit in supplying sufficient air to burn the unburned fuel gases in the gas-passages, although this air had better be introduced into the furnace itself.

In well-constructed brickwork settings, with all cracks in the joints carefully plastered, the amount of loss of heat due to leaks of air is probably very small, but large cracks may cause a serious loss of economy, and they should be looked for carefully and stopped if found.

Improper Firing.—Improper firing is probably the most common of all the many causes of poor economy of steam-boilers. Sometimes

the fact that an improper method of firing is used can be learned by simple observation, but oftener it can only be known after making a series of systematic experiments. There are some kinds of firing, practised by ignorant or negligent firemen, which any one who knows anything of the subject can say at once are wrong. Among them are: (1) Putting a large quantity of coal in the furnace at a time, covering the bed so thick that the air-supply is choked and incomplete combustion necessarily takes place. (2) Firing at irregular intervals and occasionally allowing the bed of coal to burn so low that a great excess of air passes through it. (3) Neglecting to cover the whole of the grate surface, and allowing holes to form in the bed of coal.

There are other errors of firing which are not evident on ordinary inspection, which may be practised by the most careful and intelligent firemen without any suspicion that they are wrong, and which can only be discovered by making a series of boiler-tests or by analysis of the chimney-gases. Such errors are the carrying of a bed of coal either too thick or too thin for the size of coal and the force of draft, and unskilful regulation of the draft. The best method of firing is such a method as will cause the chimney-gases to contain no carbonic oxide, hydrogen, or hydrocarbon gases, and at the same time to contain not more than about 8% of free oxygen. The presence of combustible gases, even in small quantity, in the chimney-gas is proof of imperfect combustion and consequent loss of economy. The presence of from 4 to 8 per cent of free oxygen in the chimney-gas is usually a necessary accompaniment of complete combustion, but a greater quantity of free oxygen means an unnecessarily large supply of air, and consequent unnecessary loss due to carrying the excess of heated air into the chimney. The percentage of carbonic acid in the gas is of itself not as good a criterion of the furnace-conditions as the percentage of oxygen. If the percentage of carbonic acid is 13% or upwards, there is rarely any carbonic oxide present and no great excess of air, and the furnace-conditions may then be considered as very good, but a lower percentage of carbonic acid is compatible either with the presence of carbonic oxide, indicating deficient air-supply, or with an excessive amount of oxygen, two conditions incompatible with each other but both of them indicating improper furnace-conditions.

Knowing that the best furnace-condition, the one that will give maximum economy, is one that will cause the chimney-gases to contain from 4 to 8 per cent of free oxygen, how is this condition to be secured ?

If anthracite coal is the fuel, there are at least three variables which enter into the problem: (1) The size of coal. (2) The thickness of bed. (3) The force of the draft. If we consider the size of the coal to be fixed by the condition of the market price or other circumstances, then there are two variables under control at the will of the fireman, viz., the thickness of bed, and the force of the draft. Sometimes the latter is beyond his control, as when the plant is being driven to its full capacity and the draft is limited by the size of the chimney, the damper area, the areas of other gas-passages, etc., but this is a fault in the plant which should not exist. The chimney ought always to have a capacity for giving a force of draft in excess of that ordinarily needed, so that the draft of each boiler may be regulated by its damper. If both the thickness of the bed and the force of draft are under control of the fireman, he may obtain good results with either thin, thick, or medium fires, provided the force of the draft is regulated in proportion to the thickness of the fire. No rule can be given for this regulation that will be of any service. Each engineer in charge of a plant must determine for himself, by experiment or observation, the conditions of thickness of fire and the force of draft that will give the best results with the kind of coal he is using.

One general principle may be laid down which it is important to remember: The best regulation of force of draft and of thickness of fire is that which makes the hottest fire. Deficient air-supply, causing imperfect combustion, and excessive air-supply, causing too great dilution of the gases of combustion, both tend to cool the furnace. The hottest fire that can be made is one in which the air is enough in excess to insure perfect combustion, but no more. The hottest fire also is obtained when the gases of combustion show by analysis from 4 to 8 per cent of free oxygen, so that analyses of the gases form an excellent check on the working of the furnace.

In a plant containing two or more boilers connected with a single horizontal flue leading to the chimney, unless the draft of each is carefully regulated by a damper, the force of draft at each of the different boilers may greatly vary. If the force of draft at the several boilers cannot be equalized, then the thickness of coal-bed under each boiler should be regulated in proportion to the draft of each.

The attention to the proper regulation of the thickness of the bed of coal to the force of the draft, which is here recommended, may seem to be an unnecessary refinement, involving more trouble than

any value that may be gained from it, but if a saving of only 1 or 2 per cent may be made thereby, is it not worth the trouble?

There are almost no records of experiments available to show the relative results obtained by different methods of firing anthracite coal, but there are hundreds of records of tests with anthracite coal showing differences of economy of over 20%, which differences are not satisfactorily explained by differences in the type or proportions of boiler, in kind of coal, rate of driving, or in anything else in the record. It is highly probable that many of the low results are due to improper regulation of the thickness of the fire. If such low results are obtained in boiler-tests, in which efforts are made to obtain good results, it is probable that much lower results are obtained in every-day practice, in which boilers are fired year in and year out without any tests being made to determine their economy.

A notable result of the loss due to improper firing is shown in the report of Prof. Walter R. Johnson of the tests he made for the United States Navy Department in 1842 and 1843.* He tested seven different anthracite coals, six of them giving an evaporation ranging from 11.15 to 11.59 pounds, averaging 11.42 pounds of water from and at 212° per pound of combustible, and the seventh, a Lehigh coal, only 10.26 pounds, or over 10% less than the average of the other six coals. Prof. Johnson, in his report, gives no hint of the real reason why the Lehigh coal gave such a low figure, but he gives an analysis of the chimney-gases which shows the extremely low figure of 4.57 for the percentage of carbonic acid, and the very high figure of 16.7 for the percentage of oxygen. From this analysis he calculates that 47.9 pounds of air were required to burn 1 pound of the fuel, an amount which is more than double that required to burn the other coals. He says that the large proportion of unchanged air in the chimney-gases is probably due in some degree to the obstruction which the air meets in arriving at the surface of the coal, from the coat of ashes which covers its surface during its combustion. He explains the existence of this coat of ashes forming on this coal more than on all others, as being due to the purity of the ashes themselves, which hinders their vitrification and flowing away.

The true reason of Prof. Johnson's low results with this Lehigh coal is no doubt that he used too thin a bed of coal on the grate for the amount of draft he had. The rate of combustion was very low,

* *Engineering and Mining Journal*, October 24 and 31, 1891.

6.52 to 7.71 pounds of coal per square foot of grate per hour, or only half of that commonly used in good modern practice. If he had attempted to increase the rate of combustion by increasing the draft, leaving the thickness of the bed the same, he might have chilled the fire so as to put it out, but if he had thickened the bed so as to offer more obstruction to the passage of air through it, he might have obtained from the Lehigh coal as good a result as he did with other coals, which themselves are not as high as those obtained in several of the tests with anthracite coal at the Centennial Exhibition.

The difficulties met with in obtaining the proper proportion of thickness of bed to force of draft with anthracite coal are increased when we have to deal with bituminous coal, since there are other variables in the problem besides those of size of coal, thickness of bed, and force of draft. Chief of these is probably the varying rate of distillation of moisture and volatile matter, which exists not only with different coals, but with the same coal during the intervals between firings. With the highly volatile coals of Illinois, when fired by hand, a perceptible change in the furnace conditions is made every minute. Immediately after firing, the supply of air through the grates is too little to burn the gases that are being distilled; a few minutes later, when the gases have all been driven off, the air-supply is apt to be excessive, and this supply increases the longer the time which elapses until the next firing. With such coals, burned in ordinary furnaces, with hand-firing, it is scarcely possible to obtain an efficiency as high as 60% of the heating value of the coal, while with anthracite coal 75% is not uncommon. By a series of experiments, checked by analyses of the chimney-gases, it is possible to arrive at almost ideal furnace conditions, and hence to discover the proper method of firing of anthracite coal, but with bituminous coal it is impossible; and hence, with this latter coal in ordinary furnaces all kinds of firing by hand are improper; some may be worse than others, but they are all bad. Millions of tons of coal are wasted every year in the bituminous coal districts by improper kinds of furnaces and improper firing. Remedies, however, are available in improved styles of furnace and in mechanical stoking.

Insufficient Heating Surface.—A common complaint made by the purchaser of a new steam-boiler is "The boiler does not make enough steam." The complaint requires an immediate investigation, and an evaporation test should be made to determine how much steam it actually makes. The boiler has probably been guaranteed to make a

certain amount, say 3 or 4 pounds per hour for each square foot of heating surface. If the test shows that it makes less than this amount, the trouble will usually be found to be not insufficient heating surface, but either deficient draft, insufficient grate surface for the kind of coal used and for the draft available, choking up the grate by clinker, or short-circuiting of the gases. The remedies to be applied are such as will insure the burning of sufficient coal and such an arrangement of the gas-passages as will prevent the short-circuiting. If, however, the boiler is found to be evaporating the amount of water guaranteed, the seller is relieved of his responsibility, and he may properly tell the purchaser that the heating surface is insufficient, or in other words that the purchaser bought too small a boiler. The purchaser may reply to this that he has other boilers which are evaporating from 6 to 8 pounds of water per hour per square foot of heating surface, and an evaporation test may show that his statement is correct. It is very apt to show also, however, that the boilers which are driven at this rate are wasting fuel by being overdriven. The purchaser then has the option of taking means, such as increasing the area of the grate surface and the force of draft, which will cause the new boiler to burn more coal and so drive it up to the rate of 6 or 8 pounds per hour per square foot of heating surface, thus wasting coal, or of buying additional boilers sufficient to give the required amount of steam at the rate of 3 or 4 pounds, and thus saving fuel. Whether he will do the one or the other will depend on the price of coal and whether the saving will warrant the extra investment. The general relation of rate of driving to economy of fuel varies so greatly with different circumstances that it is advisable in each case of the kind under consideration to make a series of tests to determine this relation for a particular plant before deciding whether to purchase additional boilers or to drive those already in place at a more rapid rate.

If a test is made of each boiler in the plant under regular working conditions it will sometimes be found that no two of the boilers are driven at the same rate, and that an equalizing or regulation of the draft at the several boilers will effect an important saving of fuel and may increase the total capacity so as to make the purchase of additional boilers unnecessary. The author once made a test of three boilers in the same plant. The first was a long distance from the chimney; it had a small grate and large heating surface, and the draft was insufficient to cause it to develop its rated capacity. The second had a very large grate surface, was close to the chimney, had a power-

ful draft, and was developing double its rating, while wasting 30% of the fuel as compared with the other boilers. The third was between the other two in location; the size of grate and draft were so related to each other that it developed a little more than its rating and gave a very high economy. The evident remedy in this case was to cut down the grate surface and check the draft in the second boiler, and to increase both the grate surface and the draft in the first boiler. The total horse-power developed by the three boilers would then be the same, but about 10% of the fuel would have been saved, and by then increasing the draft on all the boilers a greater horse-power could be developed with the original consumption of fuel.

Insufficient heating surface is a most serious evil, and it is often unsuspected if evaporation tests are not made. It is always the cause of waste of fuel, but if the boilers give all the steam that is desired, the grate surfaces, draft and quality of coal being such that the boilers may be driven far beyond their economical rating, their waste of fuel may never be discovered, because they are never tested.

Bad Water.—The troubles arising from the character of the water used for steam-boilers are of two different kinds: 1, corrosion; 2, incrustation, or scale. Sometimes both troubles exist at the same time.

Corrosion is due to the presence in the water of some oxidizing agent, such as air, carbonic acid gas, free acids, or dissolved salts, such as magnesium chloride, which have a corrosive action upon iron and steel. The purest waters, such as rain-water and melted snow, generally contain dissolved gases, and sometimes sulphuric acid, obtained from the atmosphere in localities where great quantities of coal containing sulphur are burned, and these waters if used in boilers, the inner surfaces of which are clean and unprotected by a coating of scale, may cause pitting of the plates, or more or less general corrosion. The corrosion produced by such waters may usually be prevented by occasionally adding a little milk of lime to the water, just enough to cause a very thin coating of scale upon the plates. Pitting, which is due to dissolved gases, occurs when the boiler is merely warm to a much greater extent than when it is hot and in service. When a boiler is to be kept out of service for any length of time, particular care should be taken to insure that the water in it, if it has any corrosive tendency, should be neutralized by the addition of milk of lime.

Distilled water, such as that obtained from the returns of steam-heating systems, in which exhaust steam is used, and from surface-

condensers, is also apt to be corrosive, due to the accumulation in it of fatty acids generated by the decomposition of the vegetable or animal oils, which are often used in "compounded" lubricating oils. When such water is used, the oil should be removed from it as much as possible before it enters the boiler, and the acid should be neutralized by the addition of a very small amount of alkali.

A much more important and more dangerous cause of corrosion than those above mentioned is the use of water containing free sulphuric acid, or acid salts, such as is often found in streams in the vicinity of coal-mines, or in streams polluted by the discharge into them of refuse from dye-works, chemical-factories, and other manufacturing establishments. When such water is the only kind available for a steam-boiler, then it is necessary, in order to prevent its corroding the boiler, to neutralize the acid by adding an alkali, such as carbonate of soda, to the water. The presence of acid in the water in a boiler may be tested by drawing a small sample from the bottom gauge-cock and inserting into it a piece of blue litmus paper, which may be obtained at a drug-store. If there is free acid in the water the blue color in the paper will be changed to red. By adding alkali to the acid water, drop by drop, and stirring thoroughly, the red color will be changed back to blue as soon as the alkali becomes in excess. In order to determine the quantity of carbonate of soda which should be added to acid feed-water to neutralize the acid, a pint of it may be taken from the supply-pipe (not from the boiler, as there the acid may have become concentrated by evaporation), and a strip of blue litmus paper be immersed in it for half its length, and allowed to remain a minute or two. The blue color of the wetted portion will change to purple if the water is very slightly acid, and to red if it is more strongly acid. Then add carefully a solution of carbonate of soda, say 1 ounce dissolved in a quart of water, until the purple color begins to change to blue or the red to purple. Measuring the quantity of the solution which has been required to effect the slightest change of color gives us a means of estimating the amount of carbonate of soda which is needed to neutralize the acid in a given amount of acid feed-water, and make it slightly alkaline. When the water is exactly neutral, it will not change the color of either red or blue litmus paper. When the proportion of alkaline water of a known strength required to neutralize the acid in the feed-water has thus been determined, it may be added to the water either in the supply-tank, or pipe, in the feed-water heater, or in the boiler, as may be most convenient. When a feed-

water heater is used the alkali should be added either in it or in the supply before the water reaches the heater, for if not added until after the water passes the heater, the acid will corrode the heater. It is better always to add the alkali in the supply-tank, for the acid is apt to corrode the pump and the pipes, as well as the heater and the boiler.

When the feed-water contains simply free acid without any important amount of scale-forming material, such as lime or magnesia, the treatment by carbonate of soda is usually all that is necessary, but if lime or magnesia or both are present, the treatment becomes a more complicated matter, and it is then most desirable to call in the services of a chemist who is expert in the treatment of bad feed-waters and take his advice as to the method of purification to be adopted. In such cases it will usually be necessary to use large settling-tanks, adding caustic lime or carbonate of soda, or both, for precipitating and settling out the hydrate or carbonate of lime formed by the chemical reaction, or else to use a live-steam feed-water heater, after neutralizing the water with carbonate or caustic soda, in which the scale-forming materials will be deposited. It is necessary always to avoid using an excess of soda or other alkali, for such excess is apt to cause foaming. As the quality of the water is apt to vary from time to time, the impurities diminishing in rainy seasons and increasing in times of drought, it is advisable to have tests of the water made frequently, and to vary the amount of reagents used in accordance with the results of these tests. Organic matter, contained in sewage or in water from swamps, peat-bogs, etc., is sometimes a cause of corrosion, which may be prevented by proper chemical treatment.

Kerosene oil, which is sometimes used as a scale preventive, is said to be sometimes a cause of corrosion, due to the fact that the oil may contain traces of the sulphuric acid which was used in its purification. Water containing chloride of magnesium is apt to be corrosive, since this salt decomposes at high temperatures, liberating free acid. The acid may be neutralized by carbonate of soda.

Weakening of the plates by corrosion is one of the greatest dangers to which boilers are liable, and it should be guarded against by frequent and thorough inspection of the interior by a competent inspector, and whenever it is found no expense should be spared to prevent its continuance. If the corrosion is trifling in amount, some simple remedy may usually be found, such as rendering the water slightly alkaline by lime-water or carbonate of soda.

Sometimes a remedy is found in hanging zinc plates in the water in the boiler, suspending them by wires or rods which are soldered to the upper part of the shell, so as to make an electric connection, the zinc, the steel plates of the boiler and the corrosive water thus forming a galvanic battery, the zinc being eaten away and the iron being thus protected.

The following note on the use of zinc is taken from a report by the Committee on Boilers of the Institution of Mechanical Engineers (1884):

Of all the preservative methods adopted in the British service, the use of zinc properly distributed and fixed has been found the most effectual in saving the iron and steel surfaces from corrosion, and also in neutralizing by its own deterioration the hurtful influences met with in water as ordinarily supplied to boilers. The zinc slabs now used in the navy boilers are 12 in. long, 6 in. wide, and $\frac{1}{2}$ in. thick; this size being found convenient for general application. The amount of zinc used in new boilers at present is one slab of the above size for every 20 I.H.P., or about one square foot of zinc-surface to two square feet of grate-surface. Rolled zinc is found the most suitable for the purpose. To make the zinc properly efficient as a protector especial care must be taken to insure perfect metallic contact between the slabs and the stays or plates to which they are attached. The slabs should be placed in such positions that all the surfaces in the boiler shall be protected. Each slab should be periodically examined to see that its connection remains perfect, and to renew any that may have decayed; this examination is usually made at intervals not exceeding three months. Under ordinary circumstances of working these zinc slabs may be expected to last in fit condition from sixty to ninety days immersed in hot sea-water; but in new boilers they at first decay more rapidly. The slabs are generally secured by means of iron straps 2 in. wide and $\frac{3}{8}$ in. thick, and long enough to reach the nearest stay, to which the strap is firmly attached by screw-bolts.

On the same subject *The Locomotive* says:

Zinc is often used in boilers to prevent the corrosive action of water on the metal. The action appears to be an electrical one, the iron being one pole of the battery and the zinc being the other. The hydrogen goes to the iron shell and escapes as a gas into the steam. The oxygen goes to the zinc.

On account of this action it is generally believed that zinc will always prevent corrosion, and that it cannot be harmful to the boiler or tank. Some experiences go to disprove this belief, and in numerous cases zinc has not only been of no use, but has even been harmful. In one case a tubular boiler had been troubled with a deposit of scale consisting chiefly of organic matter and lime, and zinc was tried as a preventive. The beneficial action of the zinc was so obvious that its continued use was advised, with frequent opening of the boiler and

cleaning out of detached scale until all the old scale should be removed and the boiler become clean. Eight or ten months later the water-supply was changed, it being now obtained from another stream supposed to be free from lime and to contain only organic matter. Two or three months after its introduction the tubes and shell were found to be coated with an obstinate adhesive scale, composed of zinc oxide and the organic matter or sediment of the water used. The deposit had become so heavy in places as to cause overheating and bulging of the plates over the fire.

If the corrosion is serious it may be necessary either to change the feed-water or, if this is not practicable, to treat it with chemicals in tanks and filter it before allowing it to enter the boiler.

Grooving or channelling is a kind of local corrosion, usually found adjacent to the seams of the shell of a boiler. It is commonly due to a combination of slightly acidulated water and of strains in the boiler-shell due to expansion and contraction, which cracks the scale off the shell and exposes the clean metal. It is an extremely dangerous form of corrosion, and calls for an immediate remedy.

Incrustation and Scale.—The formation of scale is the most common of all boiler troubles. It is due to the presence in the feed-water of various substances, some of which, such as clay and finely divided vegetable or organic matter, are carried in suspension and others are carried in solution. Of the substances that are held in solution, some, such as carbonate of lime, are precipitated by heating to a temperature of 212° ; others, such as sulphate of lime, are precipitated to some extent at higher temperatures. Still others, such as common salt, cannot be precipitated at all, but remain in solution until enough water is evaporated away to cause the solution to become saturated; that is, holding the greatest possible quantity of salt in solution, when the salt begins to crystallize, and it will then rapidly form a coating on the boiler-surfaces.

When the scale-forming material is, like common salt, incapable of being precipitated by heating, but capable of forming solid masses by concentration and crystallization, it may to some extent be prevented from forming scale by frequent blowing off, so as to keep the strength of the brine below the saturation-point. This was the old practice with marine boilers using sea-water, before surface-condensers and feed-water evaporators came into use. It is still the only method by which salt water can be used in a steam-boiler. Sea-water, however, contains sulphate of lime and other impurities which will be precipitated and make scale at high temperatures.

When the scale-forming material is carried in suspension in the water, whether in the original cold feed-water, as in the case of clay in muddy water, or in fine particles precipitated by heat in the feed-water heater or in the boiler, or by the addition of chemicals, the evaporation of the water in the boiler will cause this material to accumulate, and it will give rise to trouble unless it is removed. It is apt to take any one of three forms; sometimes all three of them may be formed from the same water. The first is scum, which floats on top of the water, and may be removed by a scum-collector and a surface blow-off. The second is soft mud, which, while it is in a very soft, almost liquid condition, may be blown out through the blow-off valve, or when the boiler is laid off for cleaning may be washed out with a jet of water from a hose. The third is solid scale, ranging from a soft chalk which may easily be broken by the fingers, to hard cement or a porcelain-like substance which it is difficult to break or cut by a hammer and chisel.

The scum, which at first floats on the surface, will, if allowed to accumulate, sink and be deposited on the tubes or shell of the boiler, and will become either mud or scale. The mud, which may be washed out of the boiler, may also become cemented by the other substances precipitated from the water, or may be baked on the shell. Scale attaches itself to all the metal surfaces of the boiler, including tubes, rivet-heads, braces, etc., as well as to the shell.

The effect of scale in a boiler ordinarily is to reduce both its steam-generating capacity and its economy, since it is not a good conductor of heat, and therefore diminishes the transmission of heat through the plates. It is also often highly dangerous, whenever it accumulates to such an extent, at a part of the shell which is exposed to flame, or to very hot gases, that the plates become overheated and weakened. A thin scale may form on the tubes, be cracked off by their expansion and contraction, or detached by the action of some "boiler compound," and may then be carried by the circulation and deposited in a thick mass on the shell over the fire. This may cause a "bagged" plate, or a crack and an explosion.

The amount of the loss of economy due to scale-deposit is often overestimated. We frequently see statements published to the effect that scale $\frac{1}{16}$ inch thick will increase the quantity of fuel required by a boiler 15 per cent, $\frac{1}{4}$ inch 60 per cent, etc., but there seems to be no experimental basis for this statement. It is probable that the de-

crease of heat transmitted depends upon the kind of scale as well as upon its thickness, and that it is not proportional to the thickness, but increases at a slower rate. If the scale is dense and hard, so as to be practically waterproof, a thin coating of it may be an effective non-conductor, and it may be a source of great danger as well as of loss of economy. If, however, it is porous, as many scales are, it will allow water to pass through it to the metal surfaces of the boiler, and the decreased transmission of heat will be very slight. The author once made a test of a water-tube boiler which had a coating of scale throughout its whole heating surface of about $\frac{1}{4}$ inch thick, and obtained practically the same evaporation as he obtained a few days later after the boiler had been cleaned. This is only one case, but the result is not unreasonable when it is known that the scale was very soft and porous, and was easily removed from the tubes by scraping.

The methods of treatment adopted for the removal or prevention of scale are numerous. The most common, perhaps, is to allow it to accumulate in the boiler until it is thought to be thick enough to be a source of danger, or of loss of economy, and then to remove it by mechanical means. This may be a good enough method in some cases, especially when the water is not very bad, so that it requires several months for a coating of objectionable thickness to form, when the scale is of such a nature that it does not detach itself and accumulate in thick patches over the fire, and when the boiler is of such a construction that it is possible to clean it thoroughly, such as a water-tube boiler with straight tubes.

Another method, commonly used, is to introduce periodically into the boiler a solution of some chemical, such as caustic soda, tannate, carbonate and phosphate of soda, etc., which will cause a change in the chemical composition of the scale-forming material, making a precipitate which may be easily removed and a soluble material which may be kept below the point of concentration by occasional blowing off.

These chemicals form the base of many of the "boiler compounds," some of which may cure the disease, while many will not, although they are sold at a very high price compared with the market value of the chemicals. In relation to these compounds Mr. Albert A. Cary says:

Never use any boiler compound unless you know positively just what it is composed of, and how it will affect the impurities in your boiler and the boiler itself. In the treatment of boiler-waters, always

start with a careful analysis of the water, made by a competent chemist who has experience in this line. Next, if you are thinking of using any chemical that has been offered for treatment of your boiler-water, let your chemist analyze it. If you are dealing with straightforward people, they will generally tell you the exact composition of their material, which your chemist can verify easily, after which he will be prepared to advise properly. (*Engineering Magazine*, June, 1897.)

In 1885 a report made by the Bavarian Steam-boiler Inspection Association gave a list of twenty-seven boiler compounds which had been analyzed. It commented on them as follows:

All secret compounds for removing boiler-scale should be avoided. Such secret preparations are either nonsensical or fraudulent, or contain either one of the two substances (soda or lime) recommended by the Association for removing scale, generally soda, which is colored to conceal its presence, and sometimes adulterated with useless or even injurious matter. These additions, as well as giving the compound some strange, fanciful name, are meant simply to deceive the boiler-owner and conceal from him the fact that he is buying colored soda, or similar substances, for which he is paying an exorbitant price.

Besides the methods of removing the scale after it has encrusted the boiler, and preventing its formation by means of chemicals introduced into the boiler and frequent blowing off, there are many ways of treating water to remove its scale-forming material before allowing it to enter the boiler. A common method, and for some kinds of water one of the best, is to heat the water in an open feed-water heater. If the scale-forming material is simply bicarbonate of lime, that is, mono-carbonate held in solution by carbonic-acid gas dissolved in the water, it may be almost entirely precipitated by continued heating to drive off the carbonic-acid gas. The insoluble carbonate thus precipitated will attach itself to the plates of the heater, which therefore needs to be cleaned frequently. Even sulphate of lime can be precipitated to a considerable extent by heating it to about 300° in a live-steam feed-water heater, such as the Hoppes.

When the water is very bad, the feed-water heaters may prove insufficient to purify it, and then recourse must be had to treatment of the water by chemicals in tanks, and subsequent slow settling or filtration to remove the sediment formed. Hydrate or milk of lime, carbonate of soda and caustic soda are the chemicals used. This method requires a somewhat expensive equipment, and great care in its operation. It should not be undertaken without competent expert advice together with chemical analysis.

Kerosene oil, and other refined petroleum oils, heavier than kerosene, are sometimes used with good effect in boilers to prevent the scale-forming materials attaching themselves to the boiler. These oils appear to rot the scale so that it may easily be removed. Crude oil should never be used, as it gives off inflammable vapors, and leaves a tarry residuum which may form with the scale a tough, greasy deposit on the plates over the fire and cause them to burn out.

A condensed summary of the various causes of incrustation, corrosion, etc., and their remedies, is given as follows in a paper by Messrs. A. E. Hunt and G. H. Clapp, in the Transactions of the American Society of Mechanical Engineers, vol. xvii. p. 338, and credited to Prof. L. M. Norton, as follows:

CAUSES OF INCRUSTATION.

1. Deposition of suspended matter.
2. Deposition of salts from concentration.
3. Deposition of carbonates of lime and magnesia by boiling off carbonic acid, which holds them in solution.
4. Deposition of sulphates of lime, because sulphate of lime is soluble in cold water, less soluble in hot water, insoluble above 270° F.
5. Deposit of magnesia, because certain magnesium salts decompose at high temperatures.
6. Deposition of lime-soap, iron-soap, etc., formed by saponification of grease.

METHODS OF PREVENTING INCRUSTATION.

1. Filtration.
2. Blowing off.
3. Use of internal collecting apparatus, or devices for directing the circulation.
4. Heating feed-water.
5. Chemical or other treatment of water in boiler.
6. Introduction of zinc in boiler.
7. Chemical treatment of water outside of boiler.

| Troublesome Substance. | Trouble. | Remedy or Palliation.* |
|---|---------------|--|
| Sediment, mud, clay, etc. | Incrustation. | Filtration; blowing off. |
| Readily soluble salts. | Incrustation. | Blowing off. |
| Bicarbonates of lime, magnesia, and iron. | Incrustation. | Heating feed; addition of caustic soda, lime, etc. |

* The author has taken the liberty of altering this table somewhat from the original.

| Troublesome Substance. | Trouble. | Remedy or Palliation. |
|-------------------------------------|--|--|
| Sulphate of lime. | Incrustation. | { Addition of carbonate of soda, barium hydrate, etc. |
| Chloride of magnesium. | Corrosion. | Addition of carbonate of soda, etc. |
| Carbonate of soda in large amounts. | { Priming. | Addition of barium chloride, etc. |
| Acid (in mine-water). | Corrosion. | Alkali. |
| Dissolved carbonic acid and oxygen. | { Corrosion. | { Feed milk of lime to the boiler, to form a thin internal coating. |
| Grease (from condensed water). | { Corrosion or incrustation. | } Different cases require different remedies. Consult a specialist on the subject. |
| Organic matter (sewage). | { Priming, corrosion, or incrustation. | |

The subject of the scientific treatment of bad feed-waters is a large and complex one, and the practical application of the proper methods is rather recent in this country. Those who are further interested in this matter should consult the paper of Messrs. Hunt and Clapp, from which the above summary is taken, and also Mr. Albert A. Cary's paper on Corrosion and Scale from Feed-waters, in the *Engineering Magazine* for March, April, May, and June, 1897. Accounts of the use of petroleum for preventing incrustation will be found in *Trans. Am. Soc. M. E.*, vol. ix. and xi., a statement of the method of purification used by the Solvay Process Company, Syracuse, N. Y., in vol. xiii. p. 255, and a description of the method used on the line of the Southern Pacific Railway in a paper by Mr. Howard Stillman, in vol. xix. p. 415.

The Use of Boiler Compounds.*—To the majority of steam-users, anything that is put into a boiler to lessen troubles due to the formation of scale, is a "boiler compound," and the fact that these various so-called compounds act differently in their endeavor to accomplish their purpose is not generally understood. Such nostrums may be divided into three classes:

First—Those attacking the scale-producing material chemically. These act as reagents and combine with the matter precipitated from the feed-water, forming a third substance different from either the original precipitated solids or the "reagent," the theory being that the new substance will not form into a hard, resisting scale, and therefore can be more easily removed by blowing off or by the cleaning-tools used after the boiler is opened.

Second—Those acting mechanically upon the precipitated crystals of scale-making matter soon after they are formed. Such "compounds" are of a glutinous, starchy or oily nature, and become attached to the surface of the newly formed crystals (precipitated from

* From an article by Albert A. Cary in *American Machinist*, Dec. 7, 1899.

the water) surrounding them, as the skin does an orange; and when these crystals fall together they are thus robbed of their cement-like action, which frequently occurs when they are allowed to come in immediate contact.

Third—Those acting both mechanically (as just described) and also as a solvent, the latter action partially dissolving scale already formed, and by this “rotting” effect (as it is often called) preparing the scale for easy removal.

The “compounds” under the first division (which act chemically upon the scale-forming matter) also frequently accomplish this same rotting effect upon scale formed previous to their use. Still other divisions or sub-divisions might possibly be made, but the above will suffice for a good general idea of the subject.

Taking up our first division of this subject, we find that the principal ingredients used in such “compounds” are soda ash (or carbonate of soda) and tannin matters, while we sometimes find caustic soda, sal soda, acetic acid, and numerous other active agents which are generally less efficient in their action on the scale-forming matter and more harmful to the boiler and its fittings.

In order to disguise these very cheap chemicals and help the “compound” vender get big prices for his powder or liquid, whichever it may be, there are often added other substances which generally render the active agents less efficient, and they frequently fall unchanged to the bottom of the boiler with the scale, thus increasing the deposit and aggravating the trouble.

Such added substances include clay, chalk, sand, etc., and sometimes coloring matter is used to disguise the original chemicals, such as tobacco-juice, iron scraps, lampblack, spent tan, etc.

The principal scale-making impurities precipitated in boilers are carbonate of lime (CaCO_3), carbonate of magnesium (MgCO_3), sulphate of lime (CaSO_4) and sulphate of magnesium (MgSO_4), and although there are generally other precipitates, notice of these alone will be sufficient for the present consideration.

The chemical action taking place when some of the above-named active agents are used may be traced as follows :

Soda ash is a dry impure carbonate of soda, from which the pure alkali is afterwards made.

The carbonate of soda (Na_2CO_3) is used to act upon the sulphate of lime and magnesia, as shown in the following chemical formulæ :

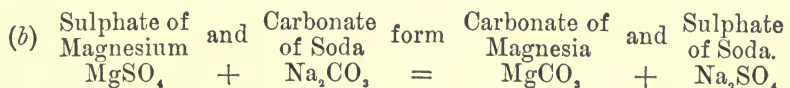
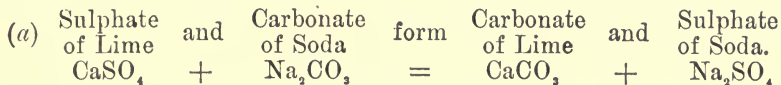

Both the carbonate of lime and carbonate of magnesia are held in solution through the presence of carbonic acid gas dissolved in the

water, which unites with them and changes the monocarbonates into bicarbonates (which are only known to exist in solution), as shown thus:

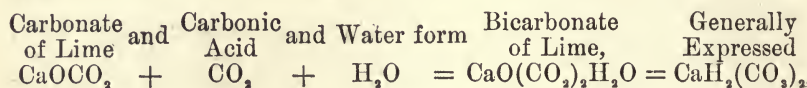

In a similar manner the bicarbonate of magnesium is formed from the monocarbonate thus:

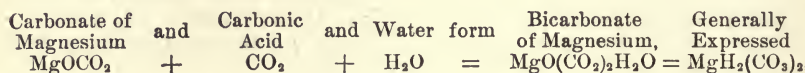

The monocarbonates (or single carbonates) of lime and magnesia are but slightly soluble in water, whereas the bicarbonates (or double carbonates) are very soluble in *cold* water, and this fact will account for the presence of the large quantities of lime and magnesia in boiler waters as carbonates.

When waters containing the bicarbonates are heated, the rise in temperature drives off the extra carbonic acid gas and leaves behind the practically insoluble monocarbonates, which are precipitated.

When a temperature of 180° Fahr. is reached, a considerable percentage of the bicarbonates is precipitated (as insoluble monocarbonates), and at 290° Fahr. (a temperature corresponding to 43 lbs. gauge-pressure) the precipitation is nearly completed, after a thorough boiling.

Scale formed from the monocarbonate of lime is seldom very troublesome, if not allowed to accumulate in too large a quantity, nor allowed to remain in the boiler for a long time; while the precipitated monocarbonate of magnesia gives slightly more trouble, due to the fact that it seldom is found in scale as a monocarbonate. All the contained carbonic acid (CO₂) is generally lost from the bicarbonate of magnesia (MgO(CO₂)₂H₂O) by the time it forms a crust, leaving behind the hydrate of magnesia (MgO + H₂O = MgO₂H₂), which acts as a cement and binds closely together (though not very strongly) whatever precipitated matter it may come in contact with.

This hydrate of magnesia is very fine and light when precipitated and requires a comparatively long time to settle.

The sulphates of lime and magnesia are very soluble, dissolving in water direct, without requiring the presence of carbonic acid or any other foreign agent.

The amount of sulphate of lime which can be dissolved in one United States gallon of water at different temperatures may be appreciated by examining the following table:

- At 32° Fahr., 120 grains per gallon.
- At 95° Fahr., 148 grains per gallon.
- At 212° Fahr., 127 grains per gallon.
- At 250° Fahr., 9 grains per gallon.
- At from 260° to 302° Fahr., it is practically insoluble.

This latter temperature (302°) corresponds to 55 lbs. gauge-pressure, and, therefore, when water is thoroughly boiled at this temperature, practically all of the sulphates will be precipitated. The crystals of sulphate of lime will be found to be long and needle-like, and also very heavy and possessing cement-like qualities, so they fall rapidly, and, mixing with the precipitated carbonates, they bind them together into a hard, resisting mass, difficult to remove with even hammer and chisel, if they form a considerable proportion of the scale.

It is here where the active agent in the compound is supposed to take effect, and by referring to the reaction given above—in the formulæ (a) and (b)—when the carbonate of soda is used, it will be seen that the sulphates of lime and magnesia are changed into carbonates, which are precipitated and form a scale varying from a more or less porous, friable crust to a “mush” or mud. The sulphate of soda, which is also formed by this reaction, is extremely soluble, remaining in solution at nearly all boiler temperatures and forming no scale, unless allowed to concentrate, and this is prevented by “blowing off” occasionally.

The tannin matters, referred to above, are obtained from various vegetable sources containing tannic acid, such as certain kinds of sumach, gallnuts, catechu (or cutch) bark, etc. Tannin is generally combined with soda to form the tannate of soda for use with boiler waters to keep the deposit soft or in suspension. Its action is supposed to be as follows:

The tannate of soda decomposes the carbonates of lime and magnesia as they enter the boiler, and tannates of lime and magnesia are precipitated in a light, flocculent, amorphous form and are long kept in suspension by the circulating currents of water, until they finally are deposited in a loose, mushy mass in that part of the boiler where the circulating currents are the weakest, or possibly in the mud-drum.

When the above reaction takes place the carbonate of soda is formed, which reacts with any sulphates that may be present, as has already been described.

The use of tannic acid in the boiler cannot be recommended unreservedly, as it will attack the iron as well as the carbonates (although, of course, more slowly), and anything that will corrode the boiler itself certainly cannot be desirable. To test this, any one can obtain a few cents' worth of tannic acid from the druggist, and by dissolving the crystals in a glass of water and adding some iron filings a very fair quality of ink can be made, due to the action of this acid on the iron.

In practice, the reaction of caustic soda ($\text{Na}_2\text{O}_2\text{H}_2$) with the sulphates seems to be more active than when the carbonate of soda is used, the probable reaction being as shown thus:

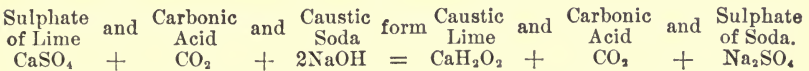

The carbonic acid used in this formula results from the precipita-

tion of the monocarbonates from the bicarbonates, as has been explained.

The secondary reaction from the result just arrived at is as follows:

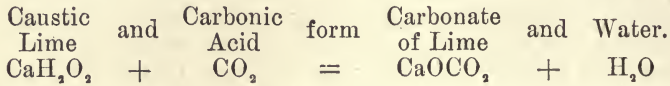

The use of caustic soda may be considered less desirable than the use of the carbonate of soda for several reasons.

In the first place this present in excess will cause violent foaming in the boiler, and with this foam often the light precipitated matter in the boiler will be carried along steam-pipes into valve-seats, gauge-glasses, etc. It will also attack and cause corrosion of the brass fittings, and it is also dangerous to handle, owing to its caustic qualities, burning the flesh painfully wherever it comes in contact.

An excess of carbonate of soda may also cause foaming in the boiler, but not as violent as when caustic soda is used.

Sal ammoniac (ammonium chloride, NH_4HCl) is most undesirable for use in a boiler, due to the liberation of hydrochloric acid (HCl) following its introduction into the boiler. This acid leaves the boiler in a vaporous form, with the steam, corroding the boiler, piping, and nearly everything it comes in contact with.

There are other "compounds" falling under this classification, of known chemical composition, which are more satisfactory than those named above, such as bisodium phosphate and trisodium phosphate, the latter being obtainable in both a hydrous and anhydrous state. The latter is less bulky and its reaction with the sulphate of lime is shown by the following formula:

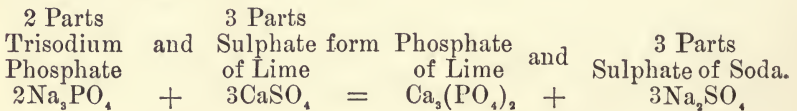

The phosphate of lime, after this reaction, falls, forming a slushy mud, making at the most a very weak crust, while the sulphate of soda remains in solution, as previously described.

The fluoride of sodium is another "compound" of known composition, which has also proved satisfactory, especially when much sulphate of magnesia is present; its reaction with the sulphate of lime being as follows:

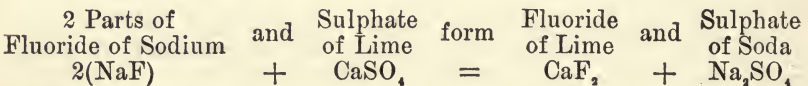

The fluoride of lime precipitated in the boiler behaves much like the phosphate of lime just described, while the remaining sulphate of soda is found in solution, as stated above.

The second division of compounds includes a class of materials

which are gradually falling into disuse, due to their proved undesirability. They thicken and foul the water in the boiler and coat its surfaces with non-conducting material, and occasionally the precipitated scale-making matter, along with this class of compound, will obstruct the passage of heat through the boiler-plates, so as to cause bagging and burning.

In this class we find slippery elm, ground bones, horns and hoofs, potatoes, dextrine, and starch, animal fats and animal or vegetable table oils.

As rapidly as the scale-forming crystals are precipitated from the feed-water, they fall into this sticky fluid and become coated with its filth, and they finally fall to the place of deposit, where they remain in a mushy, separated state until the organic matter chances to be burned out, when they will form into a loose, friable scale.

A surface blow-off or skimming device is most essential to reduce the evil, when this class of compound is used, and the bottom blow-off cock should also be opened very frequently.

The principal substances used for the third class of compounds are petroleum and kerosene.

Petroleum oil has much more of the enveloping quality described under the last (or third) classification than the kerosene. Besides producing this effect on the scale-matter, both have an active rotting effect on the scale already formed, the kerosene in this case being superior to the petroleum.

Crude oil should never be used, but a carefully refined oil, which has been deprived of its tar or wax, should be selected for this purpose, as these cause the formation of a tough, impervious scale productive of bagged sheets and collapsed flues. Petroleum or kerosene should be fed to the boiler with the feed-water, drop by drop, through a sight-feed apparatus similar to those used to feed oil to the cylinders of engines. Under no consideration should large amounts of these oils be fed to a boiler at one time, as it must be remembered that the more volatile portion of the petroleum will be quickly distilled off in the hot boiler, leaving the least efficient portion behind, while the more volatile kerosene will be vaporized very quickly, before it has time to thoroughly mix with the water.

Where hard scale has formed in a boiler, it is most effectually treated by giving it a coat of petroleum or kerosene, to partially dissolve or rot it. This may be applied with a brush or squirted on, but an easier method of application is to first fill the boiler with water above the line of scale-deposit and then pour the oil on the surface of this water and let the water gradually run out of the bottom of the boiler, thus leaving the oil behind clinging to the whole interior surface.*

* An effective method of cleaning a boiler which has become heavily coated with hard sulphate of lime scale, is to put in it a large quantity of caustic soda, say 50 lbs. for a large boiler, and boil it at atmospheric pressure, the safety-valve being opened, for several hours. This converts the hard scale into a soft substance which may be removed by a scraper, followed by thorough washing with cold water.—W. K.

As stated above, kerosene is the most effective in destroying the tenacity or coherence of this deposited scale, but this method of using either oil is not without attending danger, on account of the explosiveness of the vapor given off ; so great care must be taken to have no lights in the vicinity of the boiler under such treatment, as men have been seriously injured by this lack of prudence.

The treatment of feed-waters inside of the boiler has been a practice of many years' standing, but in the light of recent progress is not to be commended. A boiler certainly has all that it can reasonably be expected to do when it is generating steam without being called upon to perform the functions of a chemical laboratory.

The external method of treating feed-water, chemically or mechanically, is being adopted by many progressive plants in this country; but in this, Americans are far behind the English, French, Germans, Belgians, and Austrians, in whose countries the external treatment has been largely and most successfully practised for many years.

There are, of course, plants where the internal treatment of feed-water is an enforced necessity, owing to surrounding conditions or lack of funds necessary to install apparatus for external treatment, but as such apparatus has invariably proved to be an excellent investment, it should receive careful consideration from all steam-users.

External Corrosion is a frequent cause of dangerous weakening of a steam-boiler. It is most commonly due to dampness, and is therefore more liable to take place when a boiler is out of service and cold than when it is in use and constantly kept hot. The most active agent of corrosion is sulphurous acid gas, produced from the sulphur in the coal, which is converted into sulphuric acid in the presence of moisture in the cold. Mud-drums and other parts of a boiler which are farthest removed from the fire, and on which there is apt to be an accumulation of damp soot or dirt, are especially subject to external corrosion. The precautions to be taken to prevent this kind of corrosion are to have the boiler frequently inspected and to keep it clean, dry, and hot.

The Life of a Steam-boiler.—What is known as the "life" of a boiler generally depends upon the amount of corrosion to which it is subjected. With good feed-water which will neither corrode the metal nor cause the deposit of a dangerous scale, and with care to keep the outside surface perfectly dry, a life of forty years for a boiler is not uncommon. With slow corrosion its life may be reduced to five years or less, with the additional inconvenience that the pressure of steam which may be safely carried is continually being reduced during its life.

Besides corrosion other causes tending to shorten the life of a

boiler are: (1) Tendency to accumulation of scale, mud, or grease on the plates over or near to the fire, causing "bagging" of plates, leakage of seams, and sometimes explosions. (2) Overheating of riveted seams where they overlap, especially when they are covered with scale. (3) Hidden defects, due to strains or other causes, such as those described below.

Defects Discovered by Inspection.—*The Locomotive*, published by the Hartford Steam-boiler Inspection and Insurance Co., in its issue of February, 1900, gives the following statement showing the number and kind of defects discovered by the inspectors of that company during the year 1899:

During the year 1899 our inspectors made 112,464 visits of inspection, examined 221,706 boilers, inspected 85,804 boilers both internally and externally, subjected 9,371 to hydrostatic pressure, and found 779 unsafe for further use. The whole number of defects reported was 157,804, of which 12,800 were considered dangerous. A classification of the defects is given below:

SUMMARY, BY DEFECTS, FOR THE YEAR 1899.

| Nature of Defects. | Whole Number. | Dangerous. |
|---------------------------------------|---------------|------------|
| Cases of deposit of sediment..... | 11,974 | 740 |
| Cases of incrustation and scale | 29,052 | 817 |
| Cases of internal grooving..... | 1,602 | 140 |
| Cases of internal corrosion..... | 8,489 | 424 |
| Cases of external corrosion..... | 7,018 | 482 |
| Defective braces and stays | 2,166 | 809 |
| Settings defective..... | 3,990 | 304 |
| Furnaces out of shape | 4,820 | 238 |
| Fractured plates..... | 3,622 | 512 |
| Burned plates..... | 3,361 | 386 |
| Blistered plates..... | 1,952 | 74 |
| Defective rivets..... | 24,550 | 1,358 |
| Defective heads..... | 1,165 | 206 |
| Leakage around tubes..... | 31,583 | 3,403 |
| Leakage at seams..... | 4,783 | 313 |
| Water-gauges defective..... | 3,253 | 626 |
| Blow-outs defective..... | 2,059 | 581 |
| Cases of deficiency of water..... | 188 | 80 |
| Safety-valves overloaded..... | 972 | 433 |
| Safety-valves defective | 1,028 | 275 |
| Pressure-gauges defective..... | 4,947 | 394 |
| Boilers without pressure-gauges..... | 203 | 203 |
| Unclassified defects..... | 5,027 | 2 |
| Total..... | 157,804 | 12,800 |

Explosions Caused by Hidden Defects.—It is the common opinion that explosions are due to carelessness of handling by the firemen, or to negligence of inspectors in not discovering defects, but occasionally

an explosion takes place which is not due to either of these causes. On February 27, 1897, a disastrous explosion took place at the Acushnet Mills, New Bedford, Mass., wrecking a portion of the mills and killing and injuring several persons. The boiler that exploded was built in 1890. Examination showed that the break was almost identical with that of the explosion of a boiler at the Langley

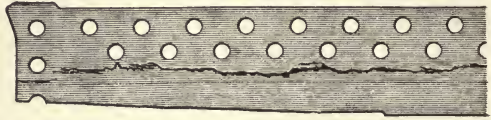

FIG. 108.—A HIDDEN CRACK.

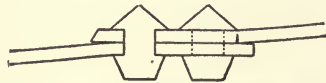

FIG. 109.—SECTION OF SEAM.

factory, Fall River, Mass., in June, 1895, which boiler was made by the same builders that made the boiler in New Bedford. The boiler parted in a horizontal seam of the middle sheet, close to the rivet-holes, and under the lap, and the fault was owing to a crack in the plates under the outer edge of the rivet-heads, as shown in the accompanying cuts, Figs. 108 and 109. *The Locomotive* speaking of this class of fractures says:

Most of the fractures of the plate are undoubtedly due to the bending of the plates in the rolls. From 30 to 40 per cent of the sectional area of the plate is removed along the line of the joint by punching or drilling the rivet-holes; and when the part that is thus weakened is passing through the rolls, the curvature of the plates at this point is sensibly increased. When the plates thus affected are brought into position for riveting they will not lie closely, but have to be knocked together with a sledge, or forced together hydrostatically, before the rivets can be driven. This means that there is a severe local strain left in the plates, the effects of which are likely to become visible at some time in the subsequent history of the boiler. When the joint has been riveted up, the parts of the plate that lie under the heads of the rivets are held together so firmly that the yielding action that occurs in every boiler, as the pressure and temperature vary, will not be felt at this point, but will be transferred to a line lying at, or just beyond, the edge of the rivet-heads. In the course of time these slight changes of form, when combined with the stress already existing along this line from the cause just described, are likely to develop a crack starting from the inside surface of the outer plate, at a place completely hidden from view, and extending insidiously outward, until the final rupture of the plate is accomplished, and the boiler gives way in a violent explosion.

Here is the record of an explosion due to a cause that had been concealed for seven years, and which cause was so hidden that it could not be found by either external or internal inspection.

It may be said that this accident and that at the Langley mill, in 1895, would not have happened if the boilers had been properly made,

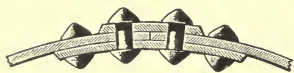

FIG. 110.—BUTT AND STRAP JOINT.

and if the riveted joint had been of the form shown in Fig. 110; but it must be remembered that the horizontal tubular boiler is favored chiefly on account of its low first cost, and low cost is generally not

compatible with the highest excellence of material and workmanship. If a cheap form of boiler is selected and the contract given to the lowest bidder, it is only to be expected that cheap material, cheap workmanship, and unskilled designers are likely to be employed in its construction.

The water- and steam-drum of a water-tube boiler being much smaller than the shell of a fire-tube boiler, and costing a much smaller percentage of its total cost, there is not the same temptation to make the drum cheap that there is with the shell boiler.

CHAPTER XIV.

EVAPORATION TESTS OF STEAM-BOILERS.

Object of an Evaporation Test.—The principal object of an evaporation test of a steam-boiler is to find out how many pounds of water it evaporates under a certain set of conditions in a given time, and how many pounds of coal are required to effect this evaporation. The test may be made for one or more of several purposes, viz:

1. To determine whether or not the stipulations of a contract between the seller and the buyer of a boiler (or of an appendage to the boiler, such as a furnace) have been performed.

2. To determine the relative economy of different kinds of fuel, of different kinds of furnace, or of different methods of driving.

3. To determine whether or not the boilers, as ordinarily run under the every-day conditions of the plant, are operated as economically as they should be.

4. To determine, in case the boilers either fail to furnish easily the quantity of steam desired, or else furnish it at what is supposed to be an excessive cost for fuel, whether any additional boilers are needed or whether some change in the conditions of running is a sufficient remedy for the difficulty.

For the first of the above-named purposes, it is necessary that the test should be made with every precaution to insure accuracy, such as those described in the Code of the Committee of the American Society of Mechanical Engineers, which is given below. Experts in boiler-testing should be employed, and the water fed to the boiler should be weighed, or measured in calibrated tanks, and not by a water-meter, which is apt not only to have an error at its average rate of running, but also an error which varies with every change in the rate. For the other three purposes, however, water-meters, if calibrated before and after the test by means of running water through them, at the average rate and pressure used in the test, into a tank set on a platform scale,

are sufficiently accurate, and the regular engineering force of the establishment should be capable of making the test.

In large plants, in which the yearly cost of coal amounts to some thousands of dollars, there are apt to be wastes of fuel, amounting to as much as 10 or 20 per cent of the total consumption, which are unsuspected until they are discovered by a series of tests. When several boilers discharge their gases into the same flue leading to the chimney, unless the draft conditions at each boiler are carefully equalized, one or more of the boilers is likely to be running under unfavorable draft conditions. If the boilers are of different types or different proportions of grate and heating surface, the draft and the method of firing which are best for one boiler may not be best for another. For these reasons it is important in designing and constructing a large boiler plant to arrange the feed-pipes so that a meter may at any time be placed in the feed-pipe of any one of the boilers, in order that a test of 24 hours, or a week, if desired, may easily be made. It is an easy matter to weigh all the coal used by the boiler during the test, and to keep hourly records of the coal- and water-consumption, the steam pressure, and the temperatures of the feed-water and the waste gases.

Besides the tests of each boiler in a plant, which ought to be made occasionally, say every two or three years, a continuous record of the performance of the plant may be made by having a large meter in the main feed-line, noting the water-consumption daily, weekly, or monthly, and comparing it with the monthly coal bills. In electric light and power stations the boiler-record should be compared with the record of the electric current given by the volt and ampere meters.

For all important tests, where the greatest accuracy is essential, the provisions of the Code, which is given below, should be followed.

RULES FOR CONDUCTING BOILER TRIALS. CODE OF 1899.*

I. *Determine at the outset* the specific object of the proposed trial, whether it be to ascertain the capacity of the boiler, its efficiency as a steam-generator, its efficiency and its defects under usual working conditions, the economy of some particular kind of fuel, or the effect of changes of design, proportion, or operation; and prepare for the trial accordingly.

II. *Examine the boiler*, both outside and inside; ascertain the dimensions of grates, heating surfaces, and all important parts; and

*From the report of the committee of the Am Soc. M. E. on the revision of the Society Code of 1885, relative to a standard method of conducting steam-boiler trials.

make a full record, describing the same, and illustrating special features by sketches. The area of heating surface is to be computed from the surfaces of shells, tubes, furnaces, and fire-boxes in contact with the fire or hot gases. The outside diameter of water-tubes and the inside diameter of fire-tubes are to be used in the computation. All surfaces below the mean water-level which have water on one side and products of combustion on the other are to be considered as water-heating surface, and all surfaces above the mean water-level which have steam on one side and products of combustion on the other are to be considered as superheating surface.

III. *Notice the general condition of the boiler and its equipment, and record such facts in relation thereto as bear upon the objects in view.*

If the object of the trial is to ascertain the maximum economy or capacity of the boiler as a steam-generator, the boiler and all its appurtenances should be put in first-class condition. Clean the heating surface inside and outside, remove clinkers from the grates and from the sides of the furnace. Remove all dust, soot, and ashes from the chambers, smoke-connections, and flues. Close air-leaks in the masonry and poorly fitted cleaning-doors. See that the damper will open wide and close tight. Test for air-leaks by firing a few shovels of smoky fuel and immediately closing the damper, observing the escape of smoke through the crevices, or by passing the flame of a candle over cracks in the brickwork.

IV. *Determine the character of the coal to be used.* For tests of the efficiency or capacity of the boiler for comparison with other boilers the coal should, if possible, be of some kind which is commercially regarded as a standard. For New England and that portion of the country east of the Allegheny Mountains, good anthracite egg coal, containing not over 10 per cent of ash, and semi-bituminous Clearfield (Pa.), Cumberland (Md.), and Pocahontas (Va.) coals are thus regarded. West of the Allegheny Mountains, Pocahontas (Va.) and New River (W. Va.) semi-bituminous, and Youghiogheny or Pittsburg bituminous coals are recognized as standards.* There is no special grade of coal mined in the Western States which is widely recognized as of superior quality or considered as a standard coal for boiler testing. Big Muddy lump, an Illinois coal mined in Jackson County, Ill., is suggested as being of sufficiently high grade to answer these requirements in districts where it is more conveniently obtainable than the other coals mentioned above.

For tests made to determine the performance of a boiler with a particular kind of coal, such as may be specified in a contract for the sale of a boiler, the coal used should not be higher in ash and in moisture than that specified, since increase in ash and moisture above a

* These coals are selected because they are about the only coals which possess the essentials of excellence of quality, adaptability to various kinds of furnaces, grates, boilers, and methods of firing, and wide distribution and general accessibility in the markets.

stated amount is apt to cause a falling off of both capacity and economy in greater proportion than the proportion of such increase.

V. *Establish the correctness of all apparatus used in the test for weighing and measuring.* These are:

1. Scales for weighing coal, ashes, and water.
2. Tanks, or water-meters for measuring water. Water-meters, as a rule, should only be used as a check on other measurements. For accurate work, the water should be weighed or measured in a tank.
3. Thermometers and pyrometers for taking temperatures of air, steam, feed-water, waste gases, etc.
4. Pressure-gauges, draft-gauges, etc.

The kind and location of the various pieces of testing apparatus must be left to the judgment of the person conducting the test, always keeping in mind the main object, i. e., to obtain authentic data.

VI. *See that the boiler is thoroughly heated* before the trial to its usual working temperature. If the boiler is new and of a form provided with a brick setting, it should be in regular use at least a week before the trial, so as to dry and heat the walls. If it has been laid off and become cold, it should be worked before the trial until the walls are well heated.

VII. *The boiler and connections* should be proved to be free from leaks before beginning a test, and all water-connections, including blow and extra feed-pipes, should be disconnected, stopped with blank flanges, or bled through special openings beyond the valves, except the particular pipe through which water is to be fed to the boiler during the trial. During the test the blow-off and feed-pipes should remain exposed to view.

If an injector is used, it should receive steam directly through a felted pipe from the boiler being tested.*

If the water is metered after it passes the injector, its temperature should be taken at the point where it leaves the injector. If the quantity is determined before it goes to the injector the temperature should be determined on the suction side of the injector, and if no change of temperature occurs other than that due to the injector, the temperature thus determined is properly that of the feed-water. When the temperature changes between the injector and the boiler, as by the use of a heater or by radiation, the temperature at which the water enters and leaves the injector and that at which it enters the boiler should all be taken. In that case the weight to be used is that of the water leaving the injector, computed from the heat-units if not

* In feeding a boiler undergoing test with an injector taking steam from another boiler, or from the main steam-pipe from several boilers, the evaporative results may be modified by a difference in the quality of the steam from such source compared with that supplied by the boiler being tested, and in some cases the connection to the injector may act as a drip for the main steam-pipe. If it is known that the steam from the main pipe is of the same pressure and quality as that furnished by the boiler undergoing the test, the steam may be taken from such main pipe.

directly measured, and the temperature that of the water entering the boiler.

Let w = weight of water entering the injector.

x = " " steam " " "

h_1 = heat-units per pound of water entering injector.

h_2 = " " " " " steam " "

h_3 = " " " " " water leaving "

Then, $w + x$ = weight of water leaving injector.

$$x = w \frac{h_3 - h_1}{h_2 - h_3}.$$

See that the steam-main is so arranged that water of condensation cannot run back into the boiler.

VIII. *Duration of Test.*—For tests made to ascertain either the maximum economy or the maximum capacity of a boiler, irrespective of the particular class of service for which it is regularly used, the duration should be at least 10 hours of continuous running. If the rate of combustion exceeds 25 pounds of coal per square foot of grate-surface per hour, it may be stopped when a total of 250 pounds of coal has been burned per square foot of grate.

In cases where the service requires continuous running for the whole 24 hours of the day, with shifts of firemen a number of times during that period, it is well to continue the test for at least 24 hours.

When it is desired to ascertain the performance under the working conditions of practical running, whether the boiler be regularly in use 24 hours a-day or only a certain number of hours out of each 24, the fires being banked the balance of the time, the duration should not be less than 24 hours.

IX. *Starting and Stopping a Test.*—The conditions of the boiler and furnace in all respects should be, as nearly as possible, the same at the end as at the beginning of a test. The steam-pressure should be the same; the water-level the same; the fire upon the grates should be the same in quantity and condition; and the walls, flues, etc., should be of the same temperature. Two methods of obtaining the desired equality of conditions of the fire may be used, viz.: those which were called in the Code of 1885 "the standard method" and "the alternate method," the latter being employed where it is inconvenient to make use of the standard method.*

X. *Standard Method of Starting and Stopping a Test.*—Steam being raised to the working pressure, remove rapidly all the fire from the grate, close the damper, clean the ash-pit, and as quickly as possible start a new fire with weighed wood and coal, noting the time and

*The committee concludes that it is best to retain the designations "standard" and "alternate," since they have become widely known and established in the minds of engineers and in the reprints of the Code of 1885. Many engineers prefer the "alternate" to the "standard" method on account of its being less liable to error due to cooling of the boiler at the beginning and end of a test.

the water-level * while the water is in a quiescent state, just before lighting the fire.

At the end of the test remove the whole fire, which has been burned low, clean the grates and ash-pit, note the water-level when the water is in a quiescent state, and record the time of hauling the fire. The water-level should be as nearly as possible the same as at the beginning of the test. If it is not the same, a correction should be made by computation, and not by operating the pump after the test is completed.

XI. *Alternate Method of Starting and Stopping a Test.*—The boiler being thoroughly heated by a preliminary run, the fires are to be burned low and well cleaned. Note the amount of coal left on the grate as nearly as it can be estimated; note the pressure of steam and the water-level. Note the time, and record it as the starting time. Fresh coal which has been weighed should now be fired. The ash-pits should be thoroughly cleaned at once after starting. Before the end of the test the fires should be burned low, just as before the start, and the fires cleaned in such a manner as to leave a bed of coal on the grates of the same depth, and in the same condition, as at the start. When this stage is reached, note the time and record it as the stopping time. The water-level and steam-pressures should previously be brought as nearly as possible to the same point as at the start. If the water-level is not the same as at the start, a correction should be made by computation, and not by operating the pump after the test is completed.

XII. *Uniformity of Conditions.*—In all trials made to ascertain maximum economy or capacity, the conditions should be maintained uniformly constant. Arrangements should be made to dispose of the steam so that the rate of evaporation may be kept the same from beginning to end. This may be accomplished in a single boiler by carrying the steam through a waste steam-pipe, the discharge from which can be regulated as desired. In a battery of boilers, in which only one is tested, the draft may be regulated on the remaining boilers, leaving the test-boiler to work under a constant rate of production.

Uniformity of conditions should prevail as to the pressure of steam, the height of water, the rate of evaporation, the thickness of fire, the times of firing, and quantity of coal fired at one time, and as to the intervals between the times of cleaning the fires.

The method of firing to be carried on in such tests should be dictated by the expert or person in responsible charge of the test, and the method adopted should be adhered to by the fireman throughout the test.

XIII. *Keeping the Records.*—Take note of every event connected with the progress of the trial, however unimportant it may appear.

* The gauge-glass should not be blown out within an hour before the water-level is taken at the beginning and end of a test, otherwise an error in the reading of the water-level may be caused by a change in the temperature and density to the water in the pipe leading from the bottom of the glass into the boiler.

Record the time of every occurrence and the time of taking every weight and every observation.

The coal should be weighed and delivered to the fireman in equal portions, each sufficient for not more than one hour's run, and a fresh portion should not be delivered until the previous one has all been fired. The time required to consume each portion should be noted, the time being recorded at the instant of firing the last of each portion. It is desirable that at the same time the amount of water fed into the boiler should be accurately noted and recorded, including the height of the water in the boiler, and the average pressure of steam and temperature of feed-water during the time. By thus recording the amount of water evaporated by successive portions of coal, the test may be divided into several periods if desired, and the degree of uniformity of combustion, evaporation, and economy analyzed for each period. In addition to these records of the coal and the feed-water, half hourly observations should be made of the temperature of the feed-water, of the flue-gases, of the external air in the boiler-room, of the temperature of the furnace when a furnace pyrometer is used, also of the pressure of steam, and of the readings of the instruments for determining the moisture in steam. A log should be kept on properly prepared blanks containing columns for record of the various observations.

When the "standard method" of starting and stopping the test is used, the hourly rate of combustion and of evaporation and the horse-power should be computed from the records taken during the time when the fires are in active condition. This time is somewhat less than the actual time which elapses between the beginning and end of the run. The loss of time due to kindling the fire at the beginning and burning it out at the end makes this course necessary.

XIV. *Quality of Steam.*—The percentage of moisture in the steam should be determined by the use of either a throttling or a separating steam calorimeter. The sampling nozzle should be placed in the vertical steam-pipe rising from the boiler. It should be made of $\frac{1}{2}$ -inch pipe, and should extend across the diameter of the steam-pipe to within half an inch of the opposite side, being closed at the end and perforated with not less than twenty $\frac{1}{8}$ -inch holes equally distributed along and around its cylindrical surface, but none of these holes should be nearer than $\frac{1}{2}$ inch to the inner side of the steam-pipe. The calorimeter and the pipe leading to it should be well covered with felting. Whenever the indications of the throttling or separating calorimeter show that the percentage of moisture is irregular, or occasionally in excess of 3 per cent, the results should be checked by a steam-separator placed in the steam-pipe as close to the boiler as convenient, with a calorimeter in the steam-pipe just beyond the outlet from the separator. The drip from the separator should be caught and weighed, and the percentage of moisture computed therefrom added to that shown by the calorimeter.

Superheating should be determined by means of a thermometer placed in a mercury-well inserted in the steam-pipe. The degree of

superheating should be taken as the difference between the reading of the thermometer for superheated steam and the readings of the same thermometer for saturated steam at the same pressure as determined by a special experiment, and not by reference to steam-tables.

For calculations relating to quality of steam and corrections for quality of steam, see Appendices XVIII. and XIX.

XV. *Sampling the Coal and Determining its Moisture.*—As each barrow-load or fresh portion of coal is taken from the coal-pile, a representative shovelful is selected from it and placed in a barrel or box in a cool place and kept until the end of the trial. The samples are then mixed and broken into pieces not exceeding one inch in diameter, and reduced by the process of repeated quartering and crushing until a final sample weighing about five pounds is obtained, and the size of the larger pieces are such that they will pass through a sieve with $\frac{1}{4}$ -inch meshes. From this sample two one-quart, air-tight glass preserving-jars, or other air-tight vessels which will prevent the escape of moisture from the sample, are to be promptly filled, and these samples are to be kept for subsequent determinations of moisture and of heating value and for chemical analyses. During the process of quartering, when the sample has been reduced to about 100 pounds, a quarter to a half of it may be taken for an approximate determination of moisture. This may be made by placing it in a shallow iron pan, not over three inches deep, carefully weighing it, and setting the pan in the hottest place that can be found on the brickwork of the boiler setting or flues, keeping it there for at least 12 hours, and then weighing it. The determination of moisture thus made is believed to be approximately accurate for anthracite and semi-bituminous coals, and also for Pittsburg or Youghioghenny coal; but it cannot be relied upon for coals mined west of Pittsburg, or for other coals containing inherent moisture. For these latter coals it is important that a more accurate method be adopted. The method recommended by the committee for all accurate tests, whatever the character of the coal, is described as follows:

Take one of the samples contained in the glass jars, and subject it to a thorough air-drying, by spreading it in a thin layer and exposing it for several hours to the atmosphere of a warm room, weighing it before and after, thereby determining the quantity of surface moisture it contains. Then crush the whole of it by running it through an ordinary coffee-mill adjusted so as to produce somewhat coarse grains (less than $\frac{1}{16}$ -inch), thoroughly mix the crushed sample, select from it a portion of from 10 to 50 grams, weigh it in a balance which will easily show a variation as small as 1 part in 1000, and dry in an air or sand bath at a temperature between 240 and 280 degrees Fahr. for one hour. Weigh it and record the loss, then heat and weigh it again repeatedly, at intervals of an hour or less, until the minimum weight has been reached and the weight begins to increase by oxidation of a portion of the coal. The difference between the original and the minimum weight is taken as the moisture in the air-dried coal.

This moisture test should preferably be made on duplicate samples, and the results should agree within 0.3 to 0.4 of one per cent, the mean of the two determinations being taken as the correct result. The sum of the percentage of moisture thus found and the percentage of surface moisture previously determined is the total moisture. (Appendix XI.)

XVI. *Treatment of Ashes and Refuse.*—The ashes and refuse are to be weighed in a dry state. If it is found desirable to show the principal characteristics of the ash, a sample should be subjected to a proximate analysis and the actual amount of incombustible material determined. For elaborate trials a complete analysis of the ash and refuse should be made.

XVII. *Calorific Tests and Analysis of Coal.*—The quality of the fuel should be determined either by heat-test or by analysis, or by both.

The rational method of determining the total heat of combustion is to burn the sample of coal in an atmosphere of oxygen gas, the coal to be sampled as directed in Article XV. of this code.

The chemical analysis of the coal should be made only by an expert chemist. The total heat of combustion computed from the results of the ultimate analysis may be obtained by the use of Dulong's formula (with constants modified by recent determinations), viz.:

$$14,600C + 62,000\left(H - \frac{O}{8}\right) + 4000S, \text{ in which C, H, O, and S refer}$$

to the proportions of carbon, hydrogen, oxygen, and sulphur respectively, as determined by the ultimate analysis.*

It is desirable that a proximate analysis should be made, thereby determining the relative proportions of volatile matter and fixed carbon. These proportions furnish an indication of the leading characteristics of the fuel, and serve to fix the class to which it belongs. As an additional indication of the characteristics of the fuel, the specific gravity should be determined.

XVIII. *Analysis of Flue-gases.*—The analysis of the flue-gases is an especially valuable method of determining the relative value of different methods of firing, or of different kinds of furnaces. In making these analyses great care should be taken to procure average samples—since the composition is apt to vary at different points of the flue. The composition is also apt to vary from minute to minute, and for this reason the drawings of gas should last a considerable period of time. Where complete determinations are desired, the analyses should be intrusted to an expert chemist. For approximate determinations the Orsat † or the Hempel ‡ apparatus may be used by the engineer.

* Favre and Silberman give 14,544 B.T.U. per pound carbon; Berthelot, 14,647 B.T.U. Favre and Silberman give 62,032 B.T.U. per pound hydrogen; Thomsen, 61,816 B.T.U.

† See R. S. Hale's paper on "Flue-gas Analysis," Transactions, vol. xviii. p. 901.

‡ See Hempel's "Methods of Gas Analysis" (Macmillan & Co.).

For the continuous indication of the amount of carbonic acid present in the flue-gases, an instrument may be employed which shows the weight of the sample of gas passing through it.

XIX. *Smoke Observations.*—It is desirable to have a uniform system of determining and recording the quantity of smoke produced where bituminous coal is used. The system commonly employed is to express the degree of smokiness by means of percentages dependent upon the judgment of the observer. The committee does not place much value upon a percentage method, because it depends so largely upon the personal element, but if this method is used, it is desirable that, so far as possible, a definition be given in explicit terms as to the basis and method employed in arriving at the percentage. The actual measurement of a sample of soot and smoke by some form of meter is to be preferred.

XX. *Miscellaneous.*—In tests for purposes of scientific research, in which the determination of all the variables entering into the test is desired, certain observations should be made which are in general unnecessary for ordinary tests. These are the measurement of the air-supply, the determination of its contained moisture, the determination of the amount of heat lost by radiation, of the amount of infiltration of air through the setting, and (by condensation of all the steam made by the boiler) of the total heat imparted to the water.

As these determinations are rarely undertaken, it is not deemed advisable to give directions for making them.

XXI. *Calculations of Efficiency.*—Two methods of defining and calculating the efficiency of a boiler are recommended. They are:

$$1. \text{ Efficiency of the boiler} = \frac{\text{Heat absorbed per lb. combustible}}{\text{Calorific value of 1 lb. combustible.}}$$

$$2. \text{ Efficiency of the boiler and grate} = \frac{\text{Heat absorbed per lb. coal}}{\text{Calorific value of 1 lb. coal.}}$$

The first of these is sometimes called the efficiency based on combustible, and the second the efficiency based on coal. The first is recommended as a standard of comparison for all tests, and this is the one which is understood to be referred to when the word "efficiency" alone is used without qualification. The second, however, should be included in a report of a test, together with the first, whenever the object of the test is to determine the efficiency of the boiler and furnace together with the grate (or mechanical stoker), or to compare different furnaces, grates, fuels, or methods of firing.

The heat absorbed per pound of combustible (or per pound coal) is to be calculated by multiplying the equivalent evaporation from and at 212 degrees per pound combustible (or coal) by 965.7.

XXII. *The Heat Balance.*—An approximate "heat balance," or statement of the distribution of the heating value of the coal among

the several items of heat utilized and heat lost may be included in the report of a test when analyses of the fuel and of the chimney-gases have been made. It should be reported in the following form:

HEAT BALANCE, OR DISTRIBUTION OF THE HEATING VALUE OF THE COMBUSTIBLE.
Total Heat Value of 1 lb. of Combustible.....B.T.U.

| | B.T.U. | Per Cent. |
|---|--------|-----------|
| 1. Heat absorbed by the boiler = evaporation from and at 212 degrees per pound of combustible $\times 965.7$. | | |
| 2. Loss due to moisture in coal = per cent of moisture referred to combustible $\div 100 \times [(212 - t) + 966 + 0.48 (T - 212)]$ (t = temperature of air in the boiler-room, T = that of the flue-gases). | | |
| 3. Loss due to moisture formed by the burning of hydrogen = per cent of hydrogen to combustible $\div 100 \times 9 \times [(212 - t) + 966 + 0.48 (T - 212)]$. | | |
| 4. * Loss due to heat carried away in the dry chimney-gases = weight of gas per pound of combustible $\times 0.24 \times (T - t)$. | | |
| 5. † Loss due to incomplete combustion of carbon = $\frac{\text{CO}}{\text{CO}_2 + \text{CO}} \times \frac{\text{per cent C in combustible}}{100} \times 10,150$. | | |
| 6. Loss due to unconsumed hydrogen and hydrocarbons, to heating the moisture in the air, to radiation, and unaccounted for. (Some of these losses may be separately itemized if data are obtained from which they may be calculated.) | | |
| Totals..... | | 100.00 |

XXIII. *Report of the Trial.*—The data and results should be reported in the manner given in either one of the two following tables, omitting lines where the tests have not been made as elaborately as provided for in such tables. Additional lines may be added for data relating to the specific object of the test. The extra lines should be classified under the headings provided in the tables, and numbered as per preceding line, with subletters *a*, *b*, etc. The Short Form of Report, Table No. 2, is recommended for commercial tests and as a convenient form of abridging the longer form for publication when saving of space is desirable. For elaborate trials, it is recommended that the full log of the trial be shown graphically, by means of a chart.

* The weight of gas per pound of carbon burned may be calculated from the gas analyses as follows:

Dry gas per pound carbon = $\frac{11\text{CO}_2 + 8\text{O} + 7(\text{CO} + \text{N})}{3(\text{CO}_2 + \text{CO})}$, in which CO_2 , CO , O , and N are the percentages by volume of the several gases. As the sampling and analyses of the gases in the present state of the art are liable to considerable errors, the result of this calculation is usually only an approximate one. The heat balance itself is also only approximate for this reason, as well as for the fact that it is not possible to determine accurately the percentage of unburned hydrogen or hydrocarbons in the flue-gases.

The weight of dry gas per pound of combustible is found by multiplying the dry gas per pound of carbon by the percentage of carbon in the combustible, and dividing by 100.

† CO_2 and CO are respectively the percentage by volume of carbonic acid and carbonic oxide in the flue-gases. The quantity 10,150 = No. heat-units generated by burning to carbonic acid one pound of carbon contained in carbonic oxide.

TABLE NO. 1.

DATA AND RESULTS OF EVAPORATIVE TEST.

Arranged in accordance with the Complete Form advised by the Boiler Test Committee of the American Society of Mechanical Engineers. Code of 1899.

Made by.....of.....boiler at.....to determine.....

Principal conditions governing the trial.....

Kind of fuel *.....

Kind of furnace.....

State of the weather.....

Method of starting and stopping the test ("standard" or "alternate," Art. X. and XI., Code).....

- 1. *Date of trial*.....
- 2. *Duration of trial*..... hours.

Dimensions and Proportions.

(A complete description of the boiler, and drawings of the same if of unusual type, should be given on an annexed sheet. (See Appendix X.)

- 3. *Grate-surface*.....width.....length.....area..... sq. ft.
- 4. Height of furnace..... ins.
- 5. Approximate width of air-spaces in grate..... in.
- 6. Proportion of air space to whole grate-surface..... per cent.
- 7. *Water-heating surface*..... sq. ft.
- 8. *Superheating surface*..... "
- 9. Ratio of water-heating surface to grate-surface..... — to 1.
- 10. Ratio of minimum draft area to grate-surface..... 1 to —

Average Pressures.

- 11. *Steam-pressure by gauge*..... lbs. persq. in.
- 12. *Force of draft between damper and boiler*..... ins. of water.
- 13. Force of draft in furnace..... " "
- 14. Force of draft or blast in ash-pit..... " "

Average Temperatures.

- 15. Of external air..... deg.
- 16. Of fire-room..... "
- 17. Of steam..... "
- 18. Of feed-water entering heater..... "
- 19. Of feed-water entering economizer..... "
- 20. *Of feed-water entering boiler*..... "
- 21. *Of escaping gases from boiler*..... "
- 22. Of escaping gases from economizer..... "

Fuel.

- 23. Size and condition.....
- 24. Weight of wood used in lighting fire..... lbs.
- 25. *Weight of coal as fired* †..... "
- 26. *Percentage of moisture in coal* ‡..... per cent.

* The items printed in italics correspond to the items in the "Short Form of Code."

† Including equivalent of wood used in lighting the fire, not including unburnt coal withdrawn from furnace at times of cleaning and at end of test. One pound of wood is taken to be equal to 0.4 pound of coal, or, in case greater accuracy is desired, as having a heat value equivalent to the evaporation of 6 pounds of water from and at 212 degrees per pound. (6 × 965.7 = 5794 B.T.U.) The term "as fired" means in its actual condition, including moisture.

‡ This is the total moisture in the coal as found by drying it artificially, as described in Art. XV. of Code.

| | |
|---|-----------|
| 27. Total weight of dry coal consumed..... | lbs. |
| 28. Total ash and refuse | “ |
| 29. Quality of ash and refuse..... | |
| 30. Total combustible consumed..... | lbs. |
| 31. Percentage of ash and refuse in dry coal..... | per cent. |

Proximate Analysis of Coal.

| | Of Coal. per cent. | Of Combustible. per cent. |
|---|-----------------------|------------------------------|
| 32. Fixed carbon..... | “ | “ |
| 33. Volatile matter..... | “ | “ |
| 34. Moisture..... | “ | “ |
| 35. Ash | “ | “ |
| | <hr/> | <hr/> |
| | 100 per cent. | 100 per cent. |
| 36. Sulphur, separately determined..... | “ | “ |

Ultimate Analysis of Dry Coal.

| | Of Coal. per cent. | Of Combustible. per cent. |
|---|-----------------------|------------------------------|
| 37. Carbon..... | “ | “ |
| 38. Hydrogen..... | “ | “ |
| 39. Oxygen..... | “ | “ |
| 40. Nitrogen..... | “ | “ |
| 41. Sulphur..... | “ | “ |
| 42. Ash | “ | “ |
| | <hr/> | <hr/> |
| | 100 per cent. | 100 per cent. |
| 43. Moisture in sample of coal as received..... | “ | “ |

Analysis of Ash and Refuse.

| | |
|------------------------|-----------|
| 44. Carbon | per cent. |
| 45. Earthy matter..... | “ |

Fuel per Hour.

| | |
|---|------|
| 46. Dry coal consumed per hour..... | lbs. |
| 47. Combustible consumed per hour..... | “ |
| 48. Dry coal per square foot of grate-surface per hour..... | “ |
| 49. Combustible per square foot of water-heating surface per hour.. | “ |

Calorific Value of Fuel.

| | |
|--|--------|
| 50. Calorific value by oxygen calorimeter, per lb. of dry coal..... | B.T.U. |
| 51. Calorific value by oxygen calorimeter, per lb. of combustible..... | “ “ “ |
| 52. Calorific value by analysis, per lb. of dry coal *..... | “ “ “ |
| 53. Calorific value by analysis, per lb. of combustible..... | “ “ “ |

Quality of Steam.

| | |
|---|-----------|
| 54. Percentage of moisture in steam..... | per cent. |
| 55. Number of degrees of superheating..... | deg. |
| 56. Quality of steam (dry steam = unity). (For exact determination of the factor of correction for quality of steam see Appendix XVIII.)..... | |

Water.

| | |
|--|------|
| 57. Total weight of water fed to boiler †..... | lbs. |
| 58. Equivalent water fed to boiler from and at 212 degrees..... | “ |
| 59. Water actually evaporated, corrected for quality of steam..... | “ |

* See formula for calorific value under Article XVII. of Code.
 † Corrected for inequality of water-level and of steam-pressure at beginning and end of test.

- 60. Factor of evaporation*..... lbs.
- 61. Equivalent water evaporated into dry steam from and at 212 degrees.† (Item 59 × Item 60.)..... “

Water per Hour.

- 62. Water evaporated per hour, corrected for quality of steam..... “
- 63. Equivalent evaporation per hour from and at 212 degrees†..... “
- 64. Equivalent evaporation per hour from and at 212 degrees per square foot of water-heating surface †..... “

Horse-power.

- 65. Horse-power developed. (34½ lbs. of water evaporated per hour into dry steam from and at 212 degrees, equals one horse-power) †..... H.P.
- 66. Builders' rated horse-power..... “
- 67. Percentage of builders' rated horse-power developed..... per cent.

Economic Results.

- 68. Water apparently evaporated under actual conditions per pound of coal as fired. (Item 58 ÷ Item 25.)..... lbs.
- 69. Equivalent evaporation from and at 212 degrees per pound of coal as fired. † (Item 61 ÷ Item 25)..... “
- 70. Equivalent evaporation from and at 212 degrees per pound of dry coal. † (Item 61 ÷ Item 27.)..... “
- 71. Equivalent evaporation from and at 212 degrees per pound of combustible. † (Item 61 ÷ Item 30.)..... “
(If the equivalent evaporation, Items 69, 70, and 71, is not corrected for the quality of steam, the fact should be stated.)

Efficiency.

- 72. Efficiency of the boiler; heat absorbed by the boiler per lb. of combustible divided by the heat-value of one lb. of combustible §..... per cent.
- 73. Efficiency of boiler, including the grate; heat absorbed by the boiler, per lb. of dry coal, divided by the heat-value of one lb. of dry coal..... “

Cost of Evaporation.

- 74. Cost of coal per ton of — lbs. delivered in boiler-room..... \$
- 75. Cost of fuel for evaporating 1000 lbs. of water under observed conditions..... \$
- 76. Cost of fuel used for evaporating 1000 lbs. of water from and at 212 degrees..... \$

Smoke Observations.

- 77. Percentage of smoke as observed..... per cent.
- 78. Weight of soot per hour obtained from smoke-meter..... ounces.
- 79. Volume of soot per hour obtained from smoke-meter..... cub. in.

* Factor of evaporation = $\frac{H - h}{965.7}$, in which *H* and *h* are respectively the total heat in steam of the average observed pressure, and in water of the average observed temperature of the feed.

† The symbol “U. E.,” meaning “Units of Evaporation,” may be conveniently substituted for the expression “Equivalent water evaporated into dry steam from and at 212 degrees,” its definition being given in a foot-note.

‡ Held to be the equivalent of 30 lbs. of water per hour evaporated from 100 degrees Fahr. into dry steam at 70 lbs. gauge-pressure. (See Introduction to Code.)

§ In all cases where the word “combustible” is used, it means the coal without moisture and ash, but including all other constituents. It is the same as what is called in Europe “coal dry and free from ash.”

Methods of Firing.

80. Kind of firing (spreading, alternate, or coking).....
 81. Average thickness of fire.....
 82. Average intervals between firings for each furnace during time
 when fires are in normal condition.....
 83. Average interval between times of levelling or breaking up.....

Analyses of the Dry Gases.

| | |
|---|---------------|
| 84. Carbon dioxide (CO ₂) | per cent. |
| 85. Oxygen (O)..... | " |
| 86. Carbon monoxide (CO)..... | " |
| 87. Hydrogen and hydrocarbons | " |
| 88. Nitrogen (by difference) (N)..... | " |
| | 100 per cent. |

TABLE NO. 2.

DATA AND RESULTS OF EVAPORATIVE TEST,

Arranged in accordance with the Short Form advised by the Boiler-test Committee of the American Society of Mechanical Engineers. Code of 1899.

| | |
|--|---------|
| Made by.....on.....boiler, at.....to determine..... | |
| Kind of fuel..... | |
| Kind of furnace | |
| Method of starting and stopping the test ("standard" or "alternate," Art. X. and XI., Code) | |
| Grate-surface..... | sq. ft. |
| Water-heating surface..... | " |
| Superheating surface..... | " |

Total Quantities.

| | |
|--|-----------|
| 1. Date of trial..... | |
| 2. Duration of trial..... | hours. |
| 3. Weight of coal as fired *..... | lbs. |
| 4. Percentage of moisture in coal *..... | per cent. |
| 5. Total weight of dry coal consumed..... | lbs. |
| 6. Total ash and refuse..... | " |
| 7. Percentage of ash and refuse in dry coal..... | per cent. |
| 8. Total weight of water fed to the boiler *..... | lbs. |
| 9. Water actually evaporated, corrected for moisture or super- heat in steam..... | " |
| 10. Equivalent water evaporated into dry steam from and at 212 degrees *..... | " |

Hourly Quantities.

| | |
|--|------|
| 11. Dry coal consumed per hour..... | lbs. |
| 12. Dry coal per square foot of grate-surface per hour | " |
| 13. Water evaporated per hour corrected for quality of steam.... | " |
| 14. Equivalent evaporation per hour from and at 212 degrees *... | " |
| 15. Equivalent evaporation per hour from and at 212 degrees per square foot of water-heating surface *..... | " |

* See foot-notes of Complete Form.

Average Pressures, Temperatures, etc.

- 16. Steam-pressure by gaugelbs. per sq. in.
- 17. Temperature of feed-water entering boiler..... deg.
- 18. Temperature of escaping gases from boiler.....
- 19. Force of draft between damper and boiler..... ins. of water.
- 20. Percentage of moisture in steam, or number of degrees of superheating.....per cent. or deg.

Horse-power.

- 21. Horse-power developed. (Item 14 ÷ 34½)*..... H.P.
- 22. Builders' rated horse-power "
- 23. Percentage of builders' rated horse-power developed..... per cent.

Economic Results.

- 24. Water apparently evaporated under actual conditions per pound of coal as fired. (Item 8 ÷ Item 3)..... lbs.
 - 25. Equivalent evaporation from and at 212 degrees per pound of coal as fired.* (Item 9 ÷ Item 3) "
 - 26. Equivalent evaporation from and at 212 degrees per pound of dry coal.* (Item 9 ÷ Item 5)..... "
 - 27. Equivalent evaporation from and at 212 degrees per pound of combustible.* [Item 9 ÷ (Item 5 - Item 6)]. "
- (If Items 25, 26, and 27 are not corrected for quality of steam, the fact should be stated.)

Efficiency.

- 28. Colorific value of the dry coal per pound..... B.T.U.
- 29. Colorific value of the combustible per pound..... " " "
- 30. Efficiency of boiler (based on combustible)*..... per cent.
- 31. Efficiency of boiler, including grate (based on dry coal)..... "

Cost of Evaporation.

- 32. Cost of coal per ton of — lbs. delivered in boiler-room..... \$
- 33. Cost of coal required for evaporating 1000 pounds of water from and at 212 degrees..... \$

* See foot-notes of Complete Form.

APPENDICES TO CODE OF 1899.*

* Greatly condensed from the original report. Many of the appendices in the report are omitted, and others are abridged. The initials signed to the appendices are those of the members of the committee by whom they were written, viz.: Charles E. Emery, Chas. T. Porter, Geo. H. Barrus, and William Kent; or of J. C. Hoadley, deceased, member of the committee of 1885.

APPENDIX I.

RELATIVE WEIGHTS OF WATER AND FUEL.

The elaborate directions and multiplicity of details provided for in the foregoing Code should not divert the minds of amateurs from the fact that the principal elements to be ascertained in a boiler test are the weight of water evaporated and the weight of the fuel required to produce such evaporation. If the Code be scanned closely with this thought in mind, it will be found that many of the elaborate provisions are intended to secure accuracy in determining these important elements. It is true that there are provisions embodied which do not refer directly thereto, but it is necessary that all available data be obtained so that comparisons can be made with the performances of other boilers, for the purpose of adjusting contracts, for general information, as a guide in the selection of fuel, or for improvements in the future.

C. E. E.

APPENDIX II.

OBJECT OF THE TEST.

In preparing for and conducting trials of steam-boilers, the specific object of the proposed trial should be clearly defined and steadily kept in view.

1. If it be to determine the efficiency of a given style of boiler or of boiler-setting under normal conditions, the boiler, brickwork, grates, dampers, flues, pipes, in short the whole apparatus should be carefully examined and accurately described, and any variation from a normal condition should be remedied if possible, and, if irremediable, clearly described and pointed out.

2. If it be to ascertain the condition of a given boiler or set of boilers with a view to the improvement of whatever may be faulty, the conditions actually existing should be accurately observed and clearly described.

3. If the object be to determine the relative value of two or more kinds of coal, or the actual value of any kind, exact equality of con-

ditions should be maintained if possible, or, where that is not practicable, all variations should be duly allowed for.

4. Only one variable should be allowed to enter into the problem; or, since the entire exclusion of disturbing variations cannot usually be effected, they should be kept as closely as possible within narrow limits, and allowed for with all possible accuracy.

J. C. H.

APPENDIX III.

GENERAL OBSERVATIONS.

All observations are to be made by the expert, either personally or by his assistants. No statement of any kind is to be received from the owner or persons in charge of the boiler. All possibility of anything that would falsify the results must be closely guarded against; all pipes not used must be taken away or blank flanges inserted.

A system of firing and a system of measuring the feed-water should be employed that will prove the correctness of the record, and, if errors are made, will clearly expose them.

If possible the steam generated should be condensed by passing it through a surface-condenser, where it is cooled by a strong current of water in a closed chamber. By this means the number of thermal units added may be ascertained with precision.

A boiler-test cannot be conducted properly when it is complicated by being combined with an engine-test.

C. T. P.

APPENDIX IV.

PRECAUTIONS TO BE OBSERVED IN MAKING A BOILER-TEST.

Boiler-tests are often undertaken with insufficient apparatus and assistance. It is possible for a single person to test one boiler, or even several in a battery, but it requires a great deal of labor to do so, and in many cases such person would be so fatigued as to be liable to make a simple error vitiating the results. He would, moreover, at no time be able to give proper oversight to the test, so as to prevent accidental or unauthorized interferences. It is very desirable, in fact almost indispensable, that an assistant be detailed to weigh the coal, and another to weigh or measure the water; if calorimeter tests are to be undertaken, still another assistant should be provided. The engineer in charge is then left free to oversee the work of all, and relieve either temporarily when necessary. Engineers are frequently called upon to make boiler-trials in connection with parties whose interests are antagonistic to a fair test, and frequently the voluntary assistance of busybodies is likely to produce errors in the results. It is therefore essential to have trustworthy assistants, and those of sufficient calibre not to be confused by interested parties, who will frequently en-

deavor, in the most plausible manner, to make out that a certain measure of coal has been already tallied, or that a certain tank of water has not been tallied.

In the first engine-trials at the American Institute Exhibition (1869), in the Centennial boiler-trials (1876), and since in private trials respecting performances of boilers as between the contractor and purchaser, the writer has arranged for both interests to take the data at the same moment, with instructions, if agreement could not be had, that the difference be at once referred to him.

In weighing the coal, the barrow or vessel used should be balanced on a scale and then filled to a certain definite weight. The laborer will soon learn to fill a vessel to the same weight within a few pounds by counting the number of shovels thrown in, when the change of a lump or two to or from a small box alongside the scale will balance it.

The water may be measured in one tank by filling it to one mark and pumping down to another, but this involves stopping the pump when filling the tank, thereby failing to maintain uniformity of conditions. Two tanks arranged so that each can be filled and emptied alternately are much better. A still better plan is to have a settling-tank to pump from and a measuring-tank which is emptied into it, and this plan is improved by setting the measuring-tank on a scale, and actually weighing the water. For large operations three tanks are necessary: a lower tank to pump from and two measuring-tanks, one of which is filling while the other is being emptied.

A simple tally should never be trusted. Nothing seems more reliable to an inexperienced observer than to mark 1, 2, 3, 4, with a diagonal cross mark for 5; but when there are waits of several minutes between the marks, and several operations performed after a tally is made, there will be confusion in the mind whether or not the tally has been actually made. The tallies both of weights of coal and of tanks of water should be written on separate lines, the time noted opposite each, and the records always made at the beginning or termination of some particular operation; for instance, in weighing coal at the time only when the barrel or bucket is dumped on the fire-room floor. It is desirable to have a number of coincident records of coal and water throughout the trial, so that in case of accident it may be held to have ended at one of such times. The uniformity of the operations may also be tested in this way from time to time. For this reason it will be found convenient to fire from a wheel-barrow set on a scale and to have a float or water-gauge connected with the tank from which the water is pumped; by which means the coal and water used may, in an evident way, be ascertained for any desired interval.

C. E. E.

APPENDIX X.

DESCRIPTION OF BOILER.

The report should include a complete description of the boiler, which, for special boilers, should be written out at length, but gener-

ally can conveniently be presented in tabular form substantially as follows:

Type of boiler; diameter of shell; length of shell; number of tubes; diameter of tubes; length of tubes; diameter of steam-drum; width of furnace; length of furnace; kind of grate-bars; width of air-spaces; ratio of area of grate to area of air-spaces; area of chimney; height of chimney; length of flues connecting to chimney; area of flues connecting to chimney.

Governing proportions: Grate-surface; heating surface (water, steam, total); area of draft through or between tubes; ratio grate to heating surface; ratio draft-area to grate; ratio draft-area to total heating surface; water-space; steam-space; ratio grate to water-space; ratio grate to steam-space.

C. E. E.

APPENDIX XI.

DETERMINING THE MOISTURE IN COAL.

Until recently two methods of determining moisture in coal have been in common use: first, the one usually adopted in boiler-testing, which consists in drying a large sample, fifty pounds or more, in a shallow pan placed over the boiler or flue; second, the method usually followed by chemists, of drying a one-gram sample of pulverized coal at 212° F., or a little above, for an hour, or until constant weight is obtained. Both methods are liable to large errors. In the first method, the temperature at which the drying takes place is uncertain, and there is no means of knowing whether the temperature obtained is sufficient to drive off the moisture that is held by capillary force or other attraction within the lumps of coal, which, at least in case of bituminous coals, seem to be as porous as wood, and as capable of absorbing moisture from the atmosphere. The second method is liable to greater errors in sampling than the first, and during the process of fine crushing and passing through sieves, a considerable portion of the moisture is apt to be removed by air-drying. In an extensive series of boiler-tests made by the writer in the summer of 1896, it became necessary to find more accurate means of determining moisture than either of those above described. It was found by repeated heating at gradually increasing temperatures from 212° up to 300° or over, and weighing at intervals of an hour or more, that the weight of coal continually decreased until it became nearly constant, and then a very slight increase took place, which increase became greater on further repeated heatings to temperatures above 250°. It has often been stated that if coal is heated above 212° F., volatile matter will be driven off; but repeated tests on seventeen different varieties of coal mined in western Pennsylvania, Ohio, Indiana, Illinois, and Kentucky invariably showed a gradual decrease of weight to a minimum, followed by the increase, as stated above, and in no single case was there any perceptible odor or other indication of volatile matter passing off below a tem-

perature of 350°. The fact that no volatile matter was given off was further proved by heating the coal in a glass retort and catching the vapor driven off in a bottle filled with water and inverted in a basin; the air displaced from the retort by expansion due to the heating displacing the water in the bottle. When the retort was cooled, after being heated to 350° in an oil bath, the air thus expanded contracted, and returned from the bottle to the retort, leaving the bottle full of water, as at the beginning of the heating, showing that no gas had been given off, except possibly such exceedingly small amount as might be absorbed by the water. The method described in Section XV. of the report was then adopted as the best available method of determining the moisture in these coals. Its accuracy was further checked by other methods.*

The new method of drying and its results were communicated by the writer to Prof. R. C. Carpenter of Cornell University, shortly after they were made, and he thereupon began experimenting with the method, and fully confirmed the writer's conclusions. In a letter dated May 18, 1897, he says: "We have investigated the moisture question, and find that in all the samples tested, some four or five in number, there is no appreciable loss between temperatures 250 and 350 degrees; at least the loss is less than our means of weighing." In his paper on "Hygrometric Properties of Coals," presented at the Hartford meeting (Transactions, vol. xviii. p. 948), he says:

"With the most volatile coals, there is no sensible loss of weight due to driving off the volatile matter under a temperature of 380° Fahr., and with anthracite coal there is no sensible loss under a temperature of 700° Fahr."

W. K.

APPENDIX XII.

PROXIMATE ANALYSES OF COAL.

For comparing the proximate analyses of different coals it is desirable that they should be reported in a uniform style. The four constituents determined by heating in a crucible should be given, and their sum should equal 100 per cent. When sulphur is determined it should be stated separately, and it should not be subtracted from the fixed carbon and the volatile matter (half from each as is the custom of some chemists, or 0.4 from one and 0.6 from the other, as is the custom of others), since it cannot be known what proportion of sulphur escapes from the crucible with the volatile matter and what proportion is burned with the fixed carbon. The carbon ratio, that is, the ratio of fixed carbon to volatile matter, should also be stated, preferably as percentages

*For scientific investigations in which extreme accuracy is desired, the author would suggest that the coal be dried in an atmosphere of nitrogen, to avoid oxidation, and that the moisture driven off be absorbed by chloride of calcium and weighed. The loss of weight by the coal should equal the gain of weight by the chloride of calcium if no volatile matter is driven off.

of their sum, thus: 40 per cent volatile matter, 60 per cent fixed carbon, which is equivalent to a carbon ratio of $1\frac{1}{2}$.

The proximate analysis is a most valuable means of identifying the general character of the coal. First, the amount of volatile matter, expressed as a percentage of the combustible, distinguishes between the anthracite, the semi-bituminous, and the bituminous coals. Second, among the bituminous coals the moisture is an important guide to the character of the coal. Third, the ash is also a criterion of the coal's value. Fourth, the sulphur taken in connection with the ash is also an indication of the value of the fuel, as high sulphur generally is found in a coal which clinkers badly, and with which it is difficult to obtain the rated capacity of a boiler.

W. K.

APPENDIX XV.

DETERMINATION OF THE MOISTURE IN THE STEAM.

The throttling steam calorimeter, first described by Professor Peabody in the *Transactions* vol. x. page 327, and its modifications by Mr. Barrus, vol. xi. page 790; vol. xvii. page 617; and by Professor Carpenter, vol. xii. page 840; also the separating calorimeter designed by Professor Carpenter, vol. xvii. page 608; which instruments are used to determine the moisture existing in a small sample of steam taken from the steam-pipe, give results, when properly handled, which may be accepted as accurate within 0.5 per cent (this percentage being computed on the total quantity of the steam) for the sample taken. The possible error of 0.5 per cent is the aggregate of the probable error of careful observation, and of the errors due to inaccuracy of the pressure-gauges and thermometers, to radiation, and, in the case of the throttling-calorimeter, to the possible inaccuracy of the figure 0.48 for the specific heat of superheated steam, which is used in computing the results. It is, however, by no means certain that the sample represents the average quality of the steam in the pipe from which the sample is taken. The practical impossibility of obtaining an accurate sample, especially when the percentage of moisture exceeds two or three per cent, is shown in the two papers by Professor Jacobus in *Transactions*, vol. xvi. pages 448, 1017.

In trials of the ordinary forms of horizontal shell and of water-tube boilers, in which there is a large disengaging surface, when the water-level is carried at least 10 inches below the level of the steam outlet, and when the water is not of a character to cause foaming, and when in the case of water-tube boilers the steam outlet is placed in the rear of the middle of the length of the water-drum, the maximum quantity of moisture in the steam rarely, if ever, exceeds two per cent; and in such cases a sample taken with the precautions specified in Article XIV. of the Code may be considered to be an accurate average sample of the steam furnished by the boiler, and its percentage of moisture as determined by the throttling or separating calorimeter

may be considered as accurate within one-half of one per cent. For scientific research, and in all cases in which there is reason to suspect that the moisture may exceed two per cent, a steam separator should be placed in the steam-pipe, as near to the steam outlet of the boiler as convenient, well covered with felting, all the steam made by the boiler passing through it, and all the moisture caught by it carefully weighed after being cooled. A convenient method of obtaining the weight of the drip from the separator is to discharge it through a trap into a barrel of cold water standing on a platform scale. A throttling or a separating calorimeter should be placed in the steam-pipe, just beyond the steam separator, for the purpose of determining, by the sampling method, the small percentage of moisture which may still be in the steam after passing through the separator.

The formula for calculating the percentage of moisture when the throttling calorimeter is used is the following:

$$w = 100 \times \frac{H - h - k(T - t)}{L},$$

in which w = percentage of moisture in the steam, H = total heat, and L = latent heat per pound of steam at the pressure in the steam-pipe, h = total heat per pound of steam at the pressure in the discharge side of the calorimeter, k = specific heat of superheated steam, T = temperature of the throttled and superheated steam in the calorimeter, and t = temperature due to the pressure in the discharge side of the calorimeter, = 212° Fahr., at atmospheric pressure. Taking $k = 0.48$ and $t = 212$, the formula reduces to

$$w = 100 \times \frac{H - 1146.6 - 0.48(T - 212)}{L}$$

W. K.

APPENDIX XVI.

CORRECTION FOR RADIATION FROM THROTTLING CALORIMETERS.

The formulæ usually given for determining moisture in a throttling calorimeter, including that given above by Mr. Kent, makes no allowance for radiation from the exterior surfaces of the instrument. It is true that this allowance is small and does not affect the results but a small fraction of 1 per cent; but it nevertheless exists, and should properly be taken into account. In my own work I have found that the radiation reduces the temperature of the wire-drawn steam some six degrees, and this represents about 0.3 of 1 per cent of moisture. My practice is to allow for the radiation by determining the normal for the instrument, as described in Appendix XVII.

It should be noted here that this normal can be readily determined when the calorimeter is attached to a horizontal section of the steam-

pipe, and the condensing surface immediately above the sampling-pipe is thus reduced to a minimum.

G. H. B.

APPENDIX XVII.

COMBINED CALORIMETER AND SEPARATOR.

The form of steam calorimeter which the writer uses is termed the "1895 pattern" universal steam calorimeter, and is a modification of the one described in the Transactions, vol. xi. page 790. It is illustrated in the accompanying cut, Fig. 111, which is reprinted from page

618, vol. xvii. in the Transactions. It consists of a throttling calorimeter and separator combined, the latter being attached to the outlet where the steam of atmospheric pressure is escaping. If the moisture is too great to be determined by the readings of the two thermometers, the separator catches the balance, and the total quantity of moisture is made up in part of that shown by the thermometers, and in part of that collected from the separator. The percentage of moisture shown by the thermometers is obtained by referring the indication of the lower thermometer to the normal reading of that thermometer with dry steam, and dividing the fall of temperature by the constant of the instrument for one per cent of moisture. The normal reading is determined by observing the indications when steam in the main pipe is in a quiescent state, and the constant is a quantity varying from 21° at 80 pounds pressure to 20° at 200 pounds pressure. The percentage of moisture, if any, discharged from the separator, is found by dividing its quantity corrected for radiation by the total quantity of steam and water passing through the instrument in the same time, as ascertained by experiment, and multiplying the result by 100.

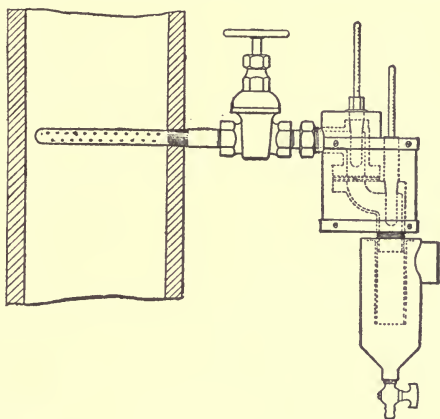

FIG. 111.—STEAM CALORIMETER.

for radiation by the total quantity of steam and water passing through the instrument in the same time, as ascertained by experiment, and multiplying the result by 100.

G. H. B.

APPENDIX XVIII.

CORRECTIONS FOR QUALITY OF STEAM.

Given the percentage of moisture or number of degrees of superheating, it is desirable to develop formulæ showing what we have termed "the factor of correction for quality of steam," or the factor

by which the "apparent evaporation" determined by a boiler-test is to be multiplied to obtain the "evaporation corrected for quality of steam." It has been customary to call the proportional weight of steam in a mixture of steam and water "the quality of the steam," and it is not desirable to change this designation. The same term applies when the steam is superheated, by employing the "equivalent evaporation," or that obtained by adding to the actual evaporation the proportional weight of water which the thermal value of the superheating would evaporate into dry steam from and at the temperature due to the pressure. "The factor of correction for quality of steam" in a boiler-test differs from the "quality" itself, from the fact that the temperature of the feed-water is lower than that of the steam.

- Let Q = quality of moist steam as described above;
 Q_1 = the quality of superheated steam as described above;
 P = the proportion of moisture in the steam;
 k = the number of degrees of superheating;
 F = the factor of correction for the quality of the steam when the steam is moist;
 F_1 = the factor of correction for the quality of the steam when the steam is superheated;
 H = the total heat of the steam due to the steam-pressure;
 L = the latent heat of the steam due to the steam-pressure;
 T = the temperature of the steam due to the steam-pressure;
 T_1 = the total heat in the water at the temperature due to the steam-pressure;*
 J = the temperature of the feed-water;
 J_1 = the total heat in the feed-water due to the temperature.*

Therefore, for moist steam:

$$Q = 1 - P, \dots \dots \dots (1)$$

$$P = 1 - Q, \dots \dots \dots (2)$$

$$Q + P = 1, \dots \dots \dots (3)$$

See also equation (6).

With both the condensing and throttling calorimeters the water and steam are withdrawn from the boiler at the temperature of the steam, and with a separator the water can only be accurately measured when under pressure, so that the difference between the steam and the moisture in the steam, as they leave the boiler, is simply that the former has received the latent heat due to the pressure and the latter has not. There is, however, imparted to the water in the boiler, not

* Most tables of the properties of steam and of water are based on the total heat of steam and water above 32 degrees Fahr. For such tables the total heat in the water at a given temperature is equal approximately to the corresponding temperature minus 32 degrees. Exact values should, however, be taken from the tables.

only the latent heat in the portion evaporated, but the sensible heat due to raising the temperature of all the water from that of the feed-water to that of the steam due to the pressure.

In equation (3) the proportional part Q receives from the boiler both the sensible and the latent heat, or the total heat above the temperature of the feed = $Q(H - J_1)$ thermal units, and the part P the difference in sensible heat between the temperatures of the steam and of the feed-water = $P(T_1 - J_1)$ thermal units. If all the water were evaporated, each pound would receive the total heat in the steam above the temperature of the feed, or $H - J_1$. "The factor of correction for the quality of the steam," when there is no superheating, is therefore

$$F = \frac{Q(H - J_1) + P(T_1 - J_1)}{H - J_1} = Q + P\left(\frac{T_1 - J_1}{H - J_1}\right). \quad (4)$$

The superheating of the steam requires 0.48 of a thermal unit for each degree the temperature of the steam is raised, so for k degrees of superheating there will be $0.48k$ thermal units per pound weight of steam and the "factor of correction for the quality of the steam" with superheating.

$$F_1 = \frac{H - J_1 + 0.48k}{H - J_1} = 1 + \frac{0.48k}{H - J_1}. \quad (5)$$

See also equation (7).

With the throttling calorimeter the percentage of moisture P , or number of degrees of superheating, are determined as explained in Appendices XV and XVI.

Since the invention of the throttling calorimeter (Appendix XV) the use of the original condensing, or so-called barrel, calorimeter is no longer warranted. Accurate results should, however, be obtained by condensing all the steam generated in the boiler and this plan has been followed in certain cases. It has, therefore, been thought desirable to add other formulæ applicable to condensing calorimeters. The following additional notation is required:

W = the original weight of the water in calorimeter, or weight of circulating water for a surface-condenser;

w = the weight of water added to the calorimeter by blowing steam into the water, or of "water of condensation" with a surface-condenser;

t = total heat of water corresponding to initial temperature of water in calorimeter;

t_1 = total heat of water corresponding to final temperature in calorimeter;

Evidently, then:

$W(t_1 - t)$ = the total thermal units withdrawn from the boiler and imparted to the water in calorimeter;

$\frac{W}{w}(t_1 - t)$ = the thermal units per pound of water withdrawn from the boiler and imparted to the water in calorimeter, from which should be deducted $T_1 - t_1$ to obtain the number of thermal units per pound of water withdrawn from the boiler at the pressure due to the temperature T .

Since only the latent heat L is imparted to the portion of the water evaporated, the quality Q , or proportional quantity evaporated, may be obtained by dividing the total thermal units per pound of water abstracted at the pressure due to the temperature T by the latent heat L . Hence,

$$Q \text{ and } Q_1 = \frac{1}{L} \left[\frac{W}{w}(t_1 - t) - (T_1 - t_1) \right]. \dots (6)$$

The value Q applies when the second term is less than unity; P may be derived therefrom by substitution in equation (2) and F from equation (4).

Q_1 applies when the second term of the above equation is greater than unity, which shows that the steam is superheated, and, as in this case, the heating value of the superheat has already been measured by heating the water of the calorimeter; the proportional thermal value of the same, in terms of the latent heat L , is represented directly by $Q_1 - 1$, and we have as the factor of correction for the quality of the steam with superheating:

$$F_1 = \frac{H - J_1 + L(Q_1 - 1)}{H - J_1} = 1 + \frac{L(Q_1 - 1)}{H - J_1} \dots (7)$$

See also equation (5).

When the quality is greater than 1, or equals Q_1 , the number of degrees of superheating:

$$k = \frac{L(Q_1 - 1)}{0.48} - 2.0833L(Q_1 - 1). \dots (8)$$

C. E. E.

APPENDIX XIX.

THE QUALITY OF SUPERHEATED STEAM.

The quality of the superheated steam is determined from the number of degrees of superheating by using the following formula:

$$Q = \frac{L + 0.48(T - t)}{L},$$

in which L is the latent heat in British thermal units in one pound of steam of the observed pressure; T the observed temperature, and

t the normal temperature due to the pressure. This normal temperature should be determined by obtaining a reading of the thermometer when the fires are in a dead condition and the superheat has disappeared; this temperature being observed when the pressure as shown by the gauge is the average of the readings taken during the trial. Observations being made by the same instrument, errors of gauge or thermometer are practically eliminated.

G. H. B.

APPENDIX XX.

EFFICIENCY OF THE BOILER.

The efficiency of the boiler, not including the grate (or the efficiency based upon combustible) is a more accurate measure of comparison of different boilers than the efficiency including the grate (or the efficiency based upon coal); for the latter is subject to a number of variable conditions, such as size and character of the coal, air-spaces between the grate-bars, skill of the fireman in saving coal from falling through the grate, etc. It is, moreover, subject to errors of sampling the coal for drying and for analysis, which affect the result to a greater degree than they do the efficiency based upon combustible, for the reason that the heating value per pound of combustible of any sample selected from a given lot, such as a car-load, of coal is practically a constant quantity and is independent of the percentage of moisture and ash in the sample; while the sample itself, upon the heating value of which the efficiency based on coal is calculated, may differ in its percentage of moisture and ash from the average coal used in the boiler-test.

When the object of a boiler-test is to determine its efficiency as an absorber of heat, or to compare it with other boilers, the efficiency based on combustible is the one which should be used; but when the object of the test is to determine the efficiency of the combination of the boiler, the furnace, and the grate, the efficiency based on coal must necessarily be used.

W. K.

APPENDIX XXI.

DISTRIBUTION OF THE HEATING VALUE OF THE FUEL.

In the operation of a steam-boiler the following distribution of the total heating value of the fuel takes place:

1. Loss of coal or coke through the grate.
2. Unburned coal or coke carried in the shape of dust or sparks beyond the bridge-wall.
3. Heating to 212° the moisture in the coal, evaporating it at that temperature, and evaporating the steam made from it to the temperature of the flue-gases, = weight of the moisture in pounds $\times [(212^{\circ} - t) + 966 + 0.48(T - 212)]$, in which T is the tempera-

ture (Fahr.) of the flue-gases and t the temperature of the external air.

4. Loss of heat due to steam which is formed by burning the hydrogen contained in the coal, and which passes into the chimney as superheated steam, = 9 times the weight of the hydrogen $\times [(212 - t) + 966 + 0.48(T - 212)]$.

5. Superheating the moisture in the air supplied to the furnace to the temperature of the flue-gases, = weight of the moisture $\times 0.48(T - t)$.

6. Heating of the gaseous products of combustion (not including steam) to the temperature of the flue, = their weight $\times 0.24(T - t)$.

7. Loss due to imperfect burning of the carbon of the coal and to non-burning of the volatile gases.

8. Radiation from the boiler and furnace.

9. Heat absorbed by the boiler, or useful work.

Item 1 depends upon the size of the spaces between the grate-bars; upon the kind of grate, as a plain, shaking, or travelling grate; upon the size of the coal; upon the character of the coal, as it requires to be more or less distributed on the grate in order to get a sufficient supply of air through it; upon the rate of driving of the furnace, rapid driving with some coals requiring more frequent shaking or cleaning of the grate than slow driving; and upon the skill of the fireman.

Item 2 depends upon the nature and fineness of the coal and upon the force of the draft. It is usually so small as to be inappreciable in its effect upon the results of the trial of a stationary boiler driven with natural draft, but in locomotives, with rapid rates of combustion, it often becomes quite important.

Item 3 depends upon the amount of moisture in the coal.

Item 4 depends upon the amount of hydrogen in the coal.

Item 5 depends upon the amount of moisture in the air. The moisture in the air may be obtained from its temperature and relative humidity, as determined by a wet-and-dry-bulb thermometer, by reference to hygrometric tables. The loss of heat due to the moisture in the air will rarely exceed 0.25 per cent of the heating value of the fuel, and it may usually, therefore, be neglected.

Item 6 depends chiefly upon the type and proportions of the boiler, and upon the rate at which it is driven. This item is usually the largest of all the heat-losses.

Items 3, 4, 5, and 6 depend also on the temperature of the flue-gases.

Item 7 depends upon the character of the coal and of the furnace, and upon the skill of the firemen. This loss may be very large, 20 per cent or more of the heating value of the coal, when highly bituminous coals are used in a furnace not adapted to them.

Item 8 depends chiefly upon the type, size, and setting of the boiler, and, when expressed as a percentage of the total heat of the fuel, upon the rate at which it is driven.

Item 9 is the heat absorbed by the boiler, or the useful work. It is also the difference between the total heating value of the coal and the sum of the losses of items 1 to 8 inclusive.

W. K.

APPENDIX XXV.

DISCREPANCY BETWEEN COMMERCIAL AND EXPERIMENTAL RESULTS.

The final result sought by manufacturers, in initiating tests of steam or other machinery in actual use, is the value of the work done measured in dollars and cents. In some cases the broad question is raised as to the saving that may be accomplished by installing improved boilers, engines, or other machinery; but more generally it is desired to ascertain what can be done to produce saving with the apparatus already in place under the actual conditions that prevail at the particular location. In both these cases it is necessary to ascertain the average cost of the work done commercially previous to the test. Frequently, in fact generally, this important fact will not be ascertained by an elaborate trial, for the reason that everything will be put in order for the test, and all details of the trial be conducted so carefully that the losses due to average carelessness or want of skill in the past will be eliminated, the engineer making the test will not receive proper credit, and the owners on seeing the report may conclude that they are already doing very well, and perhaps continue old methods with fancied security. If the cost of the output of the factory for a given time were ascertained in terms of the coal burned during the same time, and compared with the corresponding cost for the time of the trial, the latter would frequently be found to be one-eighth to one-third less than the former, and it might not be possible to tell what had caused the difference; for instance, whether it was due to putting in order the machinery prior to the tests, to greater care exercised by the fireman under the spur of careful watching, or whether, as is usually claimed, the coal was different, etc., etc. The losses are generally due in the main to the carelessness of the firemen. It follows, therefore, that the cost of the power under average conditions must be obtained in some quiet way preliminarily. Frequently the comparison of the output of the factory with the coal burned will not be sufficiently accurate, and it will be necessary to devise some corresponding check which will not interfere with the regular routine of the establishment. The work of the boilers may be checked by arranging a meter so as to continuously measure the feed-water; and its record, compared with the total weight of coal *purchased*, will frequently give the check desired. Such a check becomes more difficult when it is desirable to ascertain the performances of particular boilers, and the coal-supply is common to all boilers; but by assigning particular weighed car-loads of coal to the particular boilers, without any intimation to the firemen that they are being watched, it may be possible to ascertain the average performance of the boilers used for

the particular purpose. Preliminary experiments of this kind conducted without notice to employés, and continued through a long period, will furnish a basis for comparison with elaborate tests, and it will then be possible to point out clearly where the several losses have taken place, and the testing engineer will get the credit for the saving shown.

C. E. E.

APPENDIX XXVI.

RECORDING STEAM-GAUGE.

A good recording steam-gauge, Edson's or other, carefully adjusted, should be used and accurately compared with the steam-

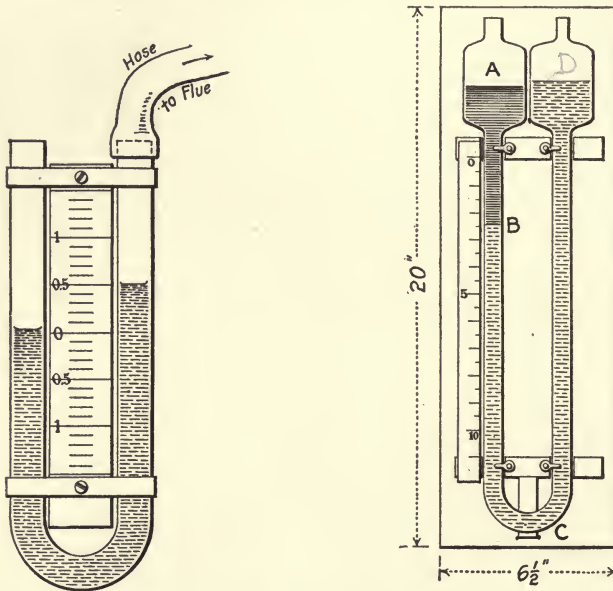

FIG. 112.—U-TUBE DRAFT-GAUGE, HALF SIZE.

FIG. 113.—BARRUS'S DRAFT-GAUGE, WITH MAGNIFIED READINGS.

gauge at stated intervals. Such an automatic record, nicely integrated, is a good check on the record of the steam-gauges.

J. C. H.

APPENDIX XXIX.

DRAFT-GAUGE.

The ordinary form of draft-gauge, consisting of the U tube (Fig. 112), containing water, lacks sensitiveness when used for measuring small quantities of draft. An instrument which the writer has used

satisfactorily for a number of years multiplies the ordinary indications as many times as desired. It consists of a U tube made of $\frac{1}{2}$ -in. glass, surmounted by two larger tubes, or chambers, having a diameter of $2\frac{1}{2}$ ins., as shown in Fig. 113. Two different liquids which will not mix, and which are of different color, are used, one occupying the portion *AB*, and the other the portion *BCD*. The movement of the line of demarcation is proportional to the difference in the areas of the chambers and of the U tube below. The liquids generally employed are alcohol colored red and a certain grade of lubricating oil. A multiplication varying from eight to ten times is obtained under these circumstances; in other words, with $\frac{1}{4}$ -in. draft the movement of the line of demarcation is some 2 ins.

The instrument is calibrated by referring it to the ordinary U-tube gauge.

G. H. B.

APPENDIX XXX.

DRAFT-GAUGE.

The accompanying sketch (Fig. 114) represents a very sensitive and accurate draft-gauge recently constructed by the writer. A light cylindrical tin can *A*, 5 ins. diameter and 6 ins. high, is inverted and suspended inside of a can *B*, 6 ins. diameter, 6 ins. high, by means of a long helical spring. Inside of the larger can a $\frac{1}{4}$ -in. tube is placed, with one end just below the level of the upper edge, while the other end passes through a hole cut in the side of the can, close to the bottom, solder being run around the tube so as to close the hole and make the can watertight. The can is filled with water to within about half an inch of the top, and the inner can is suspended by the spring so that its lower edge dips into the water, the height of the support of the spring being adjusted accordingly.

The small tube being open at both ends, the air enclosed in the can *A* is at atmospheric pressure, and the spring is extended by the weight of the can. The end of the tube which projects from the bottom of the can *B* is now connected by means of a rubber tube with a tube leading into the flue, or other chamber, whose draft or suction is to be measured, air is drawn out of the can *A* until the pressure of the remaining air is the same as that of the flue. The external atmosphere pressing on the top of the can *A* causes it to sink deeper in the water, extending the spring until its increased tension

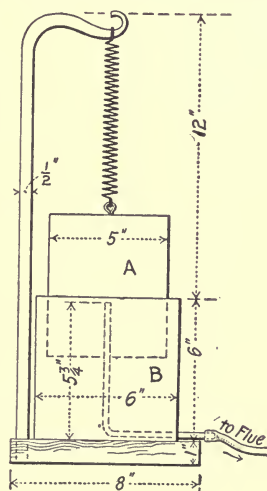

FIG. 114.—DRAFT-GAUGE FOR LIGHT PRESSURES.

just balances the difference of the opposing vertical pressures of the air inside and outside of the can. The product of this difference in pressure, expressed as a decimal fraction of a pound per square inch, multiplied by the internal area of the can in square inches, equals the tension of the spring (above that due to the weight of the can) in pounds or fraction of a pound. The extension of a helical spring being proportional to the force applied, the distance travelled downward by the can *A* measures the force of suction, that is, the draft. The movement of the can may conveniently be measured by having a celluloid scale graduated to 50ths of an inch fastened to the side of the can *A*, and a fine pointer fixed to the upper edge of the can *B*, almost touching the scale.

To reduce the readings of the scale to their equivalents in inches of water-column, as read on the ordinary U-tube gauge, we have the following formulæ:

Let *P* = force in pounds required to stretch the spring 1 in.;

E = elongation of the spring in inches;

A = area of the inner can in square inches;

d = difference in pressure or force of the draft in pounds per square inch;

D = difference in pressure in inches of water = 27.71*d*.

$$EP = Ad = \frac{AD}{27.71} = 0.0361AD,$$

$$D = \frac{27.71EP}{A},$$

$$E = \frac{0.0361AD}{P}.$$

The last equation shows that for a constant force of draft the elongation of the spring or the movement of the can may be increased by increasing the area of the can or by decreasing the strength of the spring. The strength of the spring may be increased, that is, its sensitiveness may be decreased, by increasing either its length or the diameter of the helix, or by decreasing the diameter of the wire of which it is made. We thus have at command the means of making the apparatus of any desired degree of sensitiveness.

Applying the above formulæ, let it be required to determine the movement of the can corresponding to a draft of 1 in. of water-column, the can *A* having a diameter of 5 ins. = 19.63 ins. area, and the spring of such a strength that 0.1 lb. elongates it 1 in. Here *P* = 0.1; *A* = 19.63; *D* = 1.

$$E = \frac{0.0361 \times 19.63}{0.1} = 7.09 \text{ inches.}$$

That is, the instrument multiplies the readings of the U tube 7.09 times. The precision of the instrument is, however, far greater than this figure would indicate; for in the U tube it is exceedingly difficult

to read with precision the difference in height of the two menisci, while with this apparatus readings in the scale may easily be made to $\frac{1}{50}$ in., which, with the multiplication of 7, is equivalent to $\frac{1}{350}$ of an inch of water-column. The instrument may also be calibrated by directly comparing its readings with those of an ordinary U-tube gauge.

W. K.

APPENDIX XXXI.

SAMPLING FLUE-GASES.

Very great diversities in the composition of flue-gases often exist in the same flue at the same time. To obtain a fair sample, it has been found sufficient to have one orifice to draw off gases through for each 25 sq. ins. of cross-section of flue. The pipes must be of equal diameter and of equal length. One-quarter-in. gas-pipes, all alike at the ends, and of equal lengths, answer well. Similar steel tubes will be still better (because smoother and more uniform). These should be secured in a box or block of galvanized sheet iron, equal in thickness to one course of brick, in such a manner that the open ends may be evenly distributed over the area of the flue *A* (Fig. 115), and their other open ends enclosed in the receiver *B*. If the flue-gases be drawn off from the receiver *B* by four tubes, *CC*, into a mixing-box *D* beneath, about 3-in. cube, a good mixture can be obtained. Two such "samplers," one above the other a foot apart, in the same flue, will furnish samples of gases which show by analysis the same composition.

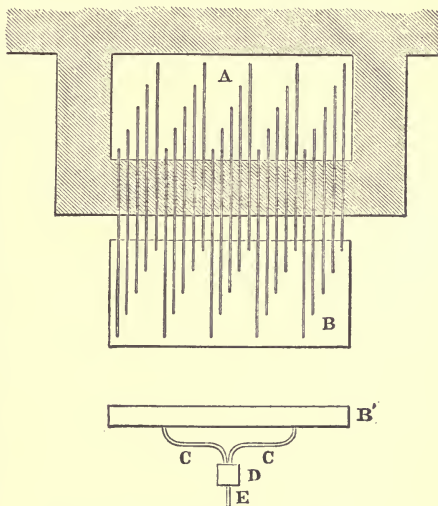

FIG. 115.—METHOD OF SAMPLING FLUE-GASES.

J. C. H.

APPENDIX XXXIII.

THE ORSAT APPARATUS FOR ANALYZING FLUE-GASES.*

The writer has made extensive use of the Orsat apparatus in his boiler-testing, and has found the work not only interesting, but exceedingly instructive and valuable. Its chief value lies in the guide which it affords in determining what kind of firing is most advantageous where the fuel is bituminous coal. In applying the results of analyses to working out the heat-balance of a boiler-test, the writer's results on various types of boilers and with various fuels have furnished a very satisfactory account of the distribution of the heat. The "unaccounted-for" quantity has ranged from 2.1 per cent up to 7 per cent in different cases. He has never found that quantity a minus one.

As to sampling the gases, the writer has found satisfactory results from using a single tube unperforated, which extends into the flue to a central point, care being taken to so locate the inlet end that it will receive what would be considered a fair sample. It is important that the connecting-tube between the flue and the instrument should be tight, and that care be taken to thoroughly exhaust the pipe of air before the sample is drawn. The connections and stop-cocks about the instrument itself should be tight and carefully manipulated. It is of the first importance that the absorbing liquids be in good condition. It is well for the engineer himself to make the cuprous chloride which is required for absorbing the carbonic oxide, and to frequently renew it in the apparatus.

The writer has found it desirable to locate the gas-apparatus on the boiler-room floor, near by the furnaces where the fires are being handled, and to carry the gases from the flue to the Orsat by means of a lead pipe of small bore. The apparatus can then be manipulated in plain view of all the operations going on in the fire-room, and in that way he can time the drawing of samples to good advantage. By using proper judgment as to when to draw the sample, satisfactory results can be obtained from analyses covering momentary drawings. For the purposes of the boiler-test and working of the heat-balance, it is preferred, however, that the drawings should cover the entire period which elapses between two successive firings.

The successful manipulation of the Orsat apparatus is not a thing which requires expert chemical knowledge, for it can be properly handled by any one, after a little practice, who is familiar with the operation of instruments of measurement.

G. H. B.

* In connection with this subject the student should read R. S. Hale's paper on "Flue-gas Analyses in Boiler Tests," with the discussion thereon, *Trans. Am. Soc. M. E.*, vol. xviii. p. 901. Consult also Gill's "Fuel and Gas Analyses," John Wiley & Sons, and Hempel's "Gas Analyses," Macmillan & Co.

W. K.

APPENDIX XXXIV.

SMOKE MEASUREMENTS.

In a series of competitive trials between two furnaces which the writer made in June, 1897, for the Detroit Water-works, a method of obtaining a continuous record of the quantity of smoke was introduced, which seems to him of great value in making specific what has heretofore been based upon the judgment of the person conducting the observations. The method referred to consisted simply in suspending, at a suitable point in the smoke-passage between the boiler and the flue, a smooth, flat, brass plate, having its face at right angles to the direction of the current. This plate served to collect a certain portion of the soot which was carried along by the waste gases, and indirectly furnished a means of sampling the gas in respect to its smokiness. The plate was 24 ins. long and $\frac{7}{8}$ in. wide, and it presented a surface amounting to 21 sq. ins. Being inserted through a hole in the top of the flue, and suspended by a wire, the hole being covered, the plate could be readily withdrawn from its place whenever desired, and the collection of soot removed by the use of a stiff brush. This was done every two hours during the progress of the trial. The quantity of soot which collected on this plate varied according to the type of the furnace and the character of the fuel, and also according to the conditions of the firing and the working conditions of the boiler. The records of the smoke-measuring device, and those of the ocular observations of the chimney, were in accord with each other. The quantity of soot which was collected, reduced to the hourly rate, varied in these tests from 9 to 184 milligrams. The method has not as yet been tried in the case of a flue carrying very dense smoke.

G. H. B.

APPENDIX XXXV.

THE RINGELMANN SMOKE-CHART.

Professor Ringelmann, of Paris, has invented a system of determining the relative density or blackness of smoke. In making observations of the smoke proceeding from a chimney, four cards ruled like those in the cut (Fig. 116), together with a card printed in solid black and another left entirely white, are placed in a horizontal row and hung at a point about 50 ft. from the observer and as nearly as convenient in line with the chimney. At this distance the lines become invisible, and the cards appear to be of different shades of gray, ranging from very light gray to almost black. The observer glances from the smoke coming from the chimney to the cards, which are numbered from 0 to 5, determines which card most nearly corresponds with the color of the smoke and makes a record accordingly, noting the time. Observations should be made continuously during

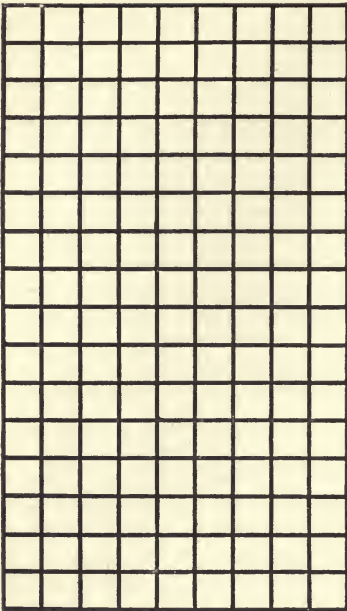

No. 1.

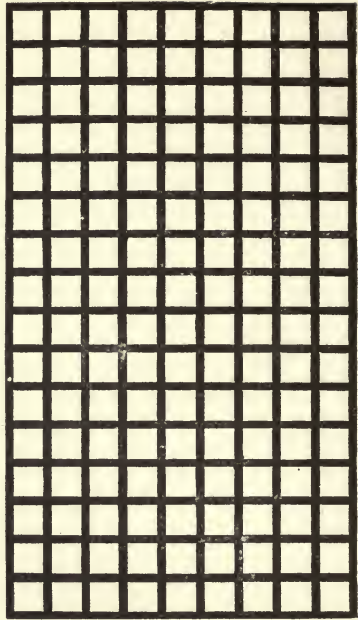

No. 2.

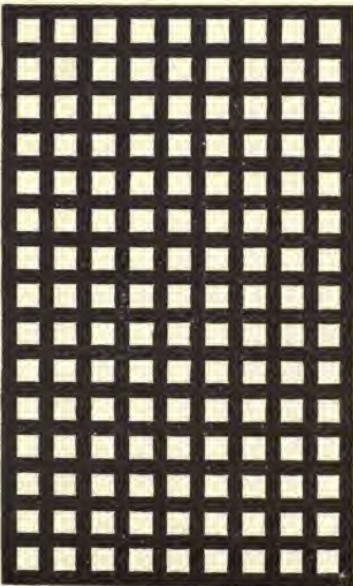

No. 3.

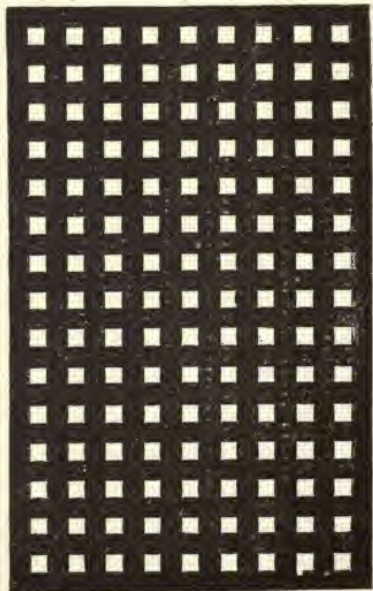

No. 4.

FIG. 116.—THE RINGELMANN SCALE FOR GRADING THE DENSITY OF SMOKE.

say one minute, and the estimated average density during that minute recorded, and so on, records being made once every minute. The average of all the records made during a boiler-test is taken as the average figure for the smoke density during the test, and the whole of the record is plotted on cross-section paper in order to show how the smoke varied in density from time to time. A rule by which the cards may be reproduced is given by Professor Ringelmann as follows:

Card 0—All white.

Card 1—Black lines 1 mm. thick, 10 mm. apart, leaving spaces 9 mm. square.

Card 2—Lines 2.3 mm. thick, spaces 7.7 mm. square.

Card 3—Lines 3.7 mm. thick, spaces 6.3 mm. square.

Card 4—Lines 5.5 mm. thick, spaces 4.5 mm. square.

Card 5—All black.

The cards as printed on the opposite page are much smaller than those used by Professor Ringelmann, but the thickness and the spacing of the lines are the same.

W. K.

APPENDIX XXXVI.

STARTING AND STOPPING A TEST.

Of the two methods of starting and stopping a test, the so-called "standard" method and the "alternate" method, the writer prefers the latter, believing that the errors in the estimation of the quantity and condition of the small amount of coal left on the grate after cleaning are less than the errors of the "standard" method, which are due: first, to cooling of the boiler at the beginning and end of the test; second, to the imperfect combustion of the fuel at the beginning; and third, to excessive air-supply through the thin fire while burning down before the end of the test.

A special caution is needed against a modification of the "alternate" method, which has been adopted by some testing engineers within the past few years. It consists in taking the starting and the stopping times each at a time subsequent to the cleaning, say after 400 lbs. of coal has been fired since the cleaning. There are two sources of serious error in this method, one causing an incorrect measurement of the coal, the other an incorrect measurement of the water. Suppose 200 lbs. of hot coke are left on the grate at the end of cleaning and 400 lbs. of fresh coal are added by the end of, say, half an hour after cleaning. If the coal left at the end of the cleaning, and the boiler-walls also, are very hot, and the coal is highly volatile and dry and the pieces of such size as not to choke the air-supply, the fire may burn so briskly that at the end of the half-hour the fuel-value of the partly-burned coal left out of the total 600 lbs. is equivalent only to 200 lbs. of coal. If, on the contrary, the hot coke on the grates at the end of the cleaning, and the boiler-walls, are considerably cooled, if the fresh coal fired is moist and of small

size, such as the slack of run-of-mine bituminous coal, which is often found in one portion of a pile in greater quantity than in another, the fire during the half-hour may burn so sluggishly that the coal and coke on the grate at the end of the half-hour may have a fuel-value equal to 400 lbs. of coal. If, in this case, it is assumed that the quantity and condition of the coal at the end of the half-hour after cleaning are the same at the starting and stopping time; and, if the fire burned briskly during the half-hour before starting and slowly during the half-hour before stopping, the boiler will be charged with more coal than was actually burned. If, on the contrary, the coal burns away more slowly during the half-hour after the cleaning before the starting time and more rapidly during the half-hour before the end of the test, the boiler is not charged with as much coal as was actually burned.

The error in water-measurement is due to the fact that the condition of the fire, and especially the quantity of flaming gases arising from it, influences the height of the water-level. A bright hot fire, or a fire with an abundance of burning gas proceeding from it, causes the water-level to rise; while anything that cools the furnace, such as freshly-fired coal, an open fire-door, or a check to the draft, causes the water-level to fall. A rise or a fall of several inches in a few seconds frequently occurs when bituminous coal is used. If the water-level is noted at the starting of the test, when it is raised by a bright fire, and at the end of a test, when it is depressed by the stoppage of violent ebullition or of rapid circulation, due to the cooling of the fire, the boiler will be credited with more water than was really evaporated, and *vice versa*.

The only correct times to be noted as the starting and the stopping times are when the smallest amount of fuel is on the grate and when it is in the most burned-out condition; that is, just before firing fresh coal after cleaning, and when the water-level is in its most quiet condition and the least raised by ebullition. The furnace-door has then been kept open for some time for cleaning and the furnace therefore is in its coolest state. This condition of fire and of water-level can be duplicated immediately after cleaning the fire; but there is no certainty of duplication of any condition when there is a bright fire and consequent rapid steaming.

These statements are not based upon theoretical considerations, but are the results of many experiments made by the writer to determine the best starting and stopping times. In a long series of tests with bituminous coals no less than six different times were recorded as starting times and as many as stopping times, and the coal apparently used and the water apparently evaporated recorded and calculated for each. These times were: *A*, before opening the first or right-hand door to clean the fire; *B*, after cleaning the first half of the furnace and just before firing fresh coal; *C*, after cleaning the second half of the furnace; *D*, after 200 lbs. of fresh coal had been fired; *E*, after 400 lbs.; *F*, after 600 lbs. By plotting the apparent

water-evaporation between *A* and *E*, both for starting and for stopping times, it was seen that there was nearly always an apparent negative evaporation between *B* and *D*, and sometimes between *B* and *C* and between *B* and *E*, due to the correction for height of observed water-level, the level rising rapidly, being much greater than the water fed by the pump. There was often no similarity of appearance of the plotted diagrams between *A* and *F* at the beginning and at the end of the same test. The possible error of water-measurement due to taking *A*, *D*, *E*, or *F* as the starting time was sometimes as much as 2000 lbs. of water, or about 3 per cent of the whole amount evaporated in a ten-hour test. The record of water evaporated between the stopping and starting times *C* occasionally differed considerably from that taken between the *B* start and stop, due to the fact that sometimes between *B* and *C* there was a sudden lighting up of the fresh coal on the cleaned side of the furnace, while at other times the fire would not light up brightly until after the *C* point had passed. It was therefore decided that the *B* time, when the furnace was the coldest and the water-level at the lowest, was the only time which could be accepted as the true starting and stopping time.

W. K.

APPENDIX XXXVII.

STARTING AND STOPPING A TEST.

Between the "standard" method and the "alternate" method of starting and stopping a test I believe the standard method, if properly followed, is the more reliable of the two for determining absolutely correct and unquestionable results. One of the important matters which the standard method determines accurately is the absolute quantity of ash and refuse. In the case of the alternate method it is extremely difficult to obtain the quantity of ash in such a way as to be positively reliable, for the reason that in cleaning the fire it is hardly possible to leave the same amount of ash, clinkers, and refuse mixed with the coal at one time as at the other. When the fire is started new with wood, and burned out at the end of the trial, as it is in pursuing the standard method of starting and stopping, there is absolutely no chance of making an error of this nature. The tendency of nearly all parties concerned in a boiler-test is to have the boiler make a good showing, and it is the rule rather than the exception that the fire at the end of the test is burned lower, if anything, than it was at the beginning, so as to surely give the boiler all the advantage to which it is entitled. With this tendency the cleaning of the fire at the end of the test is apt to be less thorough than at the beginning, so that in the first place no fuel will be lost, and in the second place that the bed of coal may not be reduced in thickness any lower than is absolutely necessary. The result is that the bed of coal at the end is apt to contain more waste material, which belongs with the ashes, than it does at the beginning, and this is one of the reasons

why the alternate method of starting and stopping a test is objectionable.

There appears to be confusion in the minds of some experts as to the facility with which a new fire can be started with wood. They appear to hold the belief that there is apt to be a great loss in getting a new fire started in this way, a loss which occurs not only in the matter of time, but also in the matter of combustion and heat. I have made a great many tests, using the standard method of starting and stopping, and my experience has been that, so far as facility of manipulation is concerned, it is perfectly easy and satisfactory to use the standard method. With a suitable quantity of dry pine-wood, preferably in the form of edgings, or 1-in. boards which have been

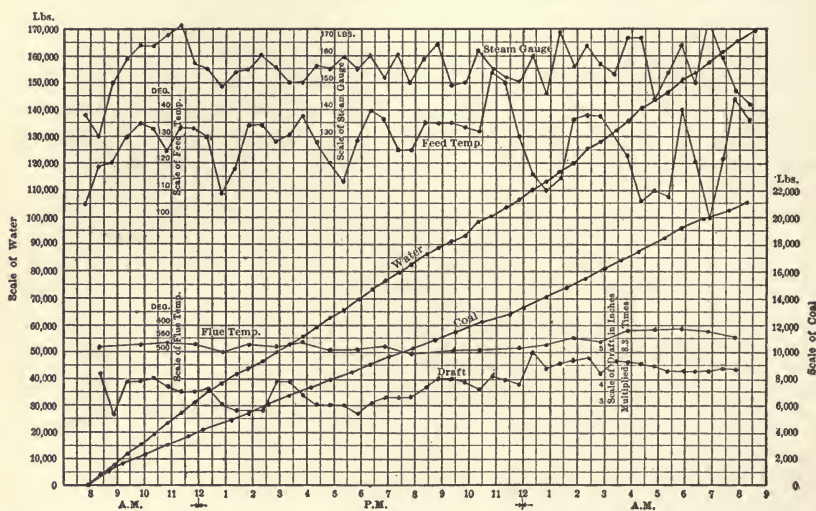

FIG. 117.—GRAPHIC RECORD OF A BOILER-TEST.

split into narrow pieces, it is quite feasible to draw the old fire, kindle a new one, and have the boiler under steam in practically a normal condition of running, with the coal selected (supposing this to be a good quality of bituminous or semi-bituminous coal) inside of 15 minutes' time. My opinion is that the objections which have been raised to starting with wood fires is due to the fact that suitable preparation has not been made in the matter of furnishing a proper kind of wood cut into proper shape. Certainly it is impossible to start a satisfactory new fire if the supply of wood contains any appreciable quantity of wet material or hard wood, or wood which is in thick pieces which do not readily ignite. I have myself had difficulty in starting a test under these circumstances, and I have no doubt that experts who have found the standard method objectionable have encountered the same obstacle and they probably base their objections largely at least on these unnecessary difficulties.

G. H. B.

APPENDIX XXXVIII.

CHART SHOWING GRAPHICALLY THE LOG OF A TRIAL.

The well-known method of plotting observations and data on cross-section paper, and making a chart applying to the test, is a useful means of representing the exact uniformity of conditions existing during a trial. Such a chart is illustrated in the appended cut (Fig. 117), in which the abscissæ represent times and the ordinates on appropriate scales the various observations and data.

G. H. B.

APPENDIX XXXIX.

CONTINUOUS DETERMINATIONS OF CARBONIC ACID IN FLUE-GASES.

Various forms of apparatus have been devised for showing continuously the percentage of carbonic acid in waste gases, and instruments of this kind, if reliable, serve a useful purpose in the management of the fires during the progress of a test. Among these instruments may be mentioned the "gas-balance" of Alphonse Custodis, the Arndt "econometer," and the Uehling & Steinbart "gas composimeter."

G. H. B.

APPENDIX XL.

MEASURING RADIATION FROM CERTAIN TYPES OF BOILERS.

(Contributed by Mr. R. S. Hale, Member of the Society.)

While the heat lost by radiation is only a small amount of the total heat if the boiler is well covered, yet it is important enough to be considered, and in the case of certain internally-fired boilers, such as the ordinary upright vertical, the Manning, the marine, the Thornycroft, etc., it can be easily determined by at least two methods. If the boiler is covered completely (or nearly so) with any boiler-covering for which the rates of flow of heat can be or have been determined, then the total loss of heat is easily computed. Thus, Norton's tests (Trans. Am. Soc. M. E., vol. xix. p. 729) give the flow per square foot per hour at various differences of temperature for many frequently-used coverings. Now if the temperature of the steam and of the air and the total exposed area is known, the loss from the whole boiler per hour is easily computed, and this loss divided by the total heat supplied in the same time gives the percentage loss by radiation. If the boiler is only partially covered, the loss from the covering and from the bare iron can be computed separately.

The second method of determining the radiation loss is, after drawing the fire, to shut all doors and dampers tight, and then to



note the time necessary for the steam-pressure to fall say 10 or 20 lbs. The fall in pressure gives the data from which the fall in temperature can be computed by means of the steam-tables, and the total loss of heat in thermal units is equal to the weight of iron and water multiplied by their respective specific heats and the fall of temperature. This divided by the time gives the total heat-units lost by radiation per hour, and the percentage loss by radiation is found as before by dividing by the total heat supplied.

It should be noted that the first method given does not apply unless the boilers are internally-fired. Neither does the second method apply if there is any brick in the furnace, or setting, since the method depends on the assumption that the temperature of the water and iron corresponds to the steam-pressure, which would not be true of the brick. The second method is also apt to give high results, as it is almost impossible to absolutely close the doors and dampers, and air leaking past them carries heat up the chimney, in addition to the true radiation.

APPENDIX XLI.

DETERMINATION OF THE MOISTURE IN STEAM FLOWING THROUGH A HORIZONTAL PIPE.

(Contributed by D. S. Jacobus, Member of the Society.)

In some cases it is impossible to place the sampling nozzle in a vertical steam-pipe rising from the boiler as recommended in Article XIV of the Code. When this is the case and it is possible to connect to a horizontal steam-pipe, the arrangement of throttling calorimeters shown in Fig. 118 gives satisfactory results.

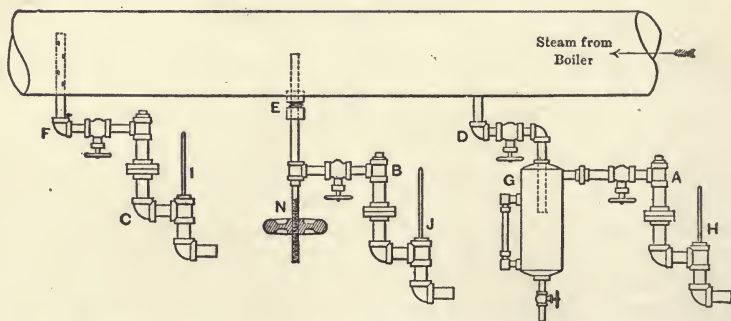

FIG. 118.—ARRANGEMENT OF THREE STEAM CALORIMETERS IN A HORIZONTAL PIPE.

The calorimeter *A* is attached to the separator *G*, which is in turn attached to the under side of the steam-pipe by the nipple *D*. The nipple *D* is made flush with the bottom of the pipe. The calorimeter *B* is attached to a nozzle having no side-holes, which passes through the stuffing-box *E*. This nozzle is adjustable so that the steam can

be drawn from any height in the pipe. When in its lowest position it is flush with the bottom of the pipe. The calorimeter *C* is attached to the perforated nipple *F*. The calorimeters are placed at some distance from an elbow or bend, so that if there is moisture in the steam it tends to run along the bottom of the pipe. This moisture will flow into the nipple *D* and collect in the separator *G*. Nearly all the moisture may sometimes be drawn out in this way, and if the calorimeters *B* and *C* indicate dry steam, the weight of moisture collected in *G* represents the entire moisture in the steam. The three calorimeters are all covered in the same way to diminish radiation, and the normal reading of the thermometers *I* and *J* used in the calorimeters *B* and *C* can ordinarily be obtained by placing them in the calorimeter *A*. The perforated nipple *F* serves to show that there is no moisture distributed through the steam, and in the case of a sudden belch of moisture it will indicate the same. Barrus calorimeters were used in our tests, and the calorimeter *A*, combined with the separator *G*, forms in reality a Barrus Universal Calorimeter. With a properly-constructed separator, the steam passing through the calorimeter *A* will be practically dry with as high as 60 lbs. of moisture drawn from the separator per hour, and, until this limit is exceeded, the normal readings of the thermometers used in the calorimeters *B* and *C* may be obtained by placing them in the calorimeter *A*, as has already been stated.

In some cases the calorimeter *C* is omitted and the amount of moisture is determined by means of the separator, with the adjustable nozzle at *E* and the separator and calorimeter *A*.

The percentage of priming *P* for the steam passing through the calorimeters *B* and *C* is given by the formula,

$$P = \frac{48}{L}(N - T),$$

where *P* = the percentage of priming;

N = the normal reading, in degrees Fahrenheit, obtained by placing the thermometers in *A*;

T = the reading when placed in either *B* or *C*;

L = the latent heat at the pressure of the steam in the steam-main in British thermal units per pound.

It is best to employ the normal reading, as Mr. Barrus recommends, in calculating the moisture corresponding to the readings of a throttling calorimeter, and not the formula given in Appendix XV of the Code; for if the formula given in Appendix XV is used, the mercury-thermometer used to measure the temperature of the steam, after passing through the orifice, must be corrected for the error produced in not heating the entire length of the stem, and must also be corrected to make the readings correspond with those that would be given by an air-thermometer. The radiation of the calorimeter must also be determined by a separate experiment, and allowed for. When the normal reading is taken, as Mr. Barrus recommends, all errors of radiation and corrections for the thermometers are eliminated.

The normal reading should be obtained either by connecting the calorimeter to a vertical nipple, with no side-holes, which projects upward in a horizontal steam-pipe, in which the steam is in a quiescent state, or it should be obtained by connecting the calorimeter to a separator, which is known to remove all the moisture. The normal reading should not be determined when the calorimeter is attached to a horizontal nipple with side-holes, placed in a vertical pipe, because should this be done the readings may be low on account of moisture, which may fall through the steam and cling to the nozzle, and, finally, be drawn into the calorimeter.

The results given by a throttling calorimeter cannot be relied on within one-fifth of 1 per cent, because experiments have shown that the quality of the "dead steam" used in obtaining the normal readings may vary by this amount.* As the quality of the "dead steam" may not be that of the steam used by Regnault in his experiments, there may be a still greater error. When the formula given in Appendix XV of the Code is used, the probable error is not eliminated, for a study of Regnault's Experiments shows that the value used in the formula for the specific heat of superheated steam may be slightly in error for the conditions involved in a throttling calorimeter. Experiments have shown that the two methods of computing the moisture agree within one-fifth of 1 per cent when the proper corrections are made for radiation and when the temperatures are reduced to the equivalents by an air-thermometer.† These experiments were made at the single pressure of 80 lbs. per sq. in. above the atmosphere, and it has not been shown that the two methods agree within this amount at all pressures, but as there should be no discrepancy provided the specific heat-factor remains constant for the conditions involved, it is probable that the two methods agree very nearly with each other at all pressures.‡

Computation of the Results of a Boiler-trial.—The following example shows a convenient method of making the calculations of the results of a trial from the observed data recorded at the trial.

The observed data used in the calculations are :

| | |
|--|------------------------------|
| a. Duration of the test..... | 10 hrs. 15 min. = 10.25 hrs. |
| b. Water apparently evaporated..... | lbs. 30,000 |
| c. Coal used..... | lbs. 3,000 |
| d. Feed-water temperature, average..... | 110° F. |
| e. Steam-pressure by gauge, average..... | lbs. 120 |
| f. Moisture in the coal..... | % 2 |
| g. Moisture in the steam..... | % 0.5 |
| h. Ash and refuse withdrawn from the fire..... | 6% = lbs. 180 |
| i. Grate-surface..... | sq. ft. 30 |
| j. Heating surface..... | sq. ft. 1,000 |

* Trans. Am. Soc. M. E., vol. xvi. p. 466.

† Trans. Am. Soc. M. E., vol. xvi. p. 460.

‡ It must not be inferred from this that the author considers the specific heat of steam to be the same at all pressures. On the contrary, he has made experiments which show that this is not the case.

The following results are calculated from these data :

- k . Factor of evaporation, from d and e , taken from table of factors, 1.15.
 b_1 Water evaporated, corrected for moisture in the steam = $b - gb = 30,000 - 150 = 29,850$ lbs.
 U.E. Water evaporated from and at 212° into dry steam = $b_1 \times k = 29,850 \times 1.15 = 34,327$ lbs.
 c_1 Dry coal = $c - f = 3000 - 60 = 2940$ lbs.
 c_2 Combustible = $c_1 - h = 2940 - 180 = 2760$ lbs.

USEFUL RESULTS.

- (1) $b \div c$ Water apparently evaporated per lb. coal, actual conditions $30,000 \div 3000 = 10$ lbs.
- (2) U.E. $\div c$ Water evaporated from and at 212° per lb. coal, $34,327 \div 3000 = 11.442$ lbs.
- (3) U.E. $\div c_1$ Water evaporated from and at 212° per lb. dry coal, $34327 \div 2940 = 11.676$.
- (4) U.E. $\div c_2$ Water evaporated from and at 212° per lb. combustible, $34,327 \div 2760 = 12.437$ lbs.
- (5) H.P. Horse-power = U.E. $\div a \div 34.5 = 34,327 \div 10.25 \div 34.5 = 97.1$ H.P.
- (6) Coal per sq. ft. grate-surface per hour, $c \div a \div i = 3000 \div 10.25 \div 30 = 9.76$ lbs.
- (7) U.E. per sq. ft. heating surface per hour, U.E. $\div a \div j = 34,327 \div 10.25 \div 1000 = 3.35$ lbs.
- (8) T. Temperature of the chimney gases, average 450° F.

Interpretation of the above results.—The results given in the last eight lines are the ones that give practically all the information that is required from any boiler-trial. All the observed data and all the computations are of use only for the purpose of obtaining these eight results. We will now consider what conclusions may be drawn by an engineer from these eight results alone, the figures themselves being accepted as correct.

1. From the result, 10 lbs. of water evaporated under actual conditions, nothing can be known concerning the efficiency of the boiler or the quality of the coal, unless the conditions of feed-water temperature, steam-pressure, and moisture in the coal and in the steam are also known. About the only use that can be made of this figure is in connection with estimates of the cost of steam-power. If the engine using the steam furnished by the boiler uses 20 lbs. of steam per horse-power per hour, then it will require $20 \div 10 = 2$ lbs. of coal per horse-power, the "actual conditions" under which the boiler is operated being the pressure of steam required by the engine and the temperature of water in the hot-well of the condenser or in the feed-water heater, both of which obtain their heat from the exhaust steam furnished by the engine.

2. The result, 11.442 lbs. evaporated from and at 212° per lb. of coal, is useful as a measure of the quality of the coal, provided the efficiency of the boiler is known. For tests of different coals with the same boiler and under the same conditions of rate of driving, kind of firing, etc., this figure is the one that will be used in comparing the relative values of the coals. It is a very high figure, and indicates both that the coal is of good quality and that the efficiency of the boiler is high.

3. The result, 11.676 U.E. per lb. of dry coal, is useful in connection with result 2, as a measure of the quality of the coal. The difference between the two results being 2% shows that that is the percentage of moisture in the coal, and this would indicate that the coal is not Western coal. The result would also be used in comparing tests of coals of one grade, but differing in surface-moisture, so as to reduce them all to the standard of dry coal. It is practically of no use in comparing coals of different grades, such as Pittsburg and Illinois coals, containing, respectively, say 2% and 12% of moisture.

4. The result, 12.437 U.E. per lb. of combustible, is the one used for comparing boiler efficiencies. If the grade of coal is known, and its heating value per lb. of combustible is either known as the result of a calorimetric test or by computation from analysis, or estimated from the average heating value per lb. combustible of coal of that grade, then the figure 12.437 divided by the quotient of the heating value of the coal divided by 965.7 will give the efficiency. The figure 12.437 being in excess of 12 lbs., which is practically the maximum value obtainable for anthracite, and beyond the maximum for bituminous coal, indicates both that the coal is semi-bituminous and that the boiler was operated with a very high efficiency. Taking the average heating value of semi-bituminous coal at 15,750 B.T.U. per lb. combustible, gives $\frac{12.437}{15,750 \div 965.7} = 76.26\%$ efficiency.

5. The result, 97.1 H.P., is the measure of the capacity of the boiler developed in the trial. This figure will be compared with the boiler's rated or nominal capacity.

6. The result, 9.76 lbs. of coal per sq. ft. of grate per hour, is the measure of rate of driving of the grate-surface. It is a rather low figure for semi-bituminous coal in average practice. Taken in connection with the high efficiency it indicates exceptionally good firing, very nice adjustment of the thickness of bed of coal on the grate to the force of the draft, and an excellent furnace, a combination of favorable conditions not often obtained.

7. The rate of driving, 3.35 U.E. per sq. ft. of heating surface per hour, is a little higher than that at which maximum economy is to be expected, but, with the exceptionally favorable conditions mentioned in the preceding paragraph, it may be the rate corresponding to maximum economy in this case.

8. The temperature of the chimney-gases, 450° F., is unusually low for semi-bituminous coal in ordinary practice. It indicates, when taken in connection with the high efficiency, which is inconsistent with air-leaks in the setting, a high furnace temperature and a clean boiler, both of which tend to produce a low chimney temperature.

CHAPTER XV.

RESULTS OF STEAM-BOILER TRIALS.

IN this chapter the results of trials of several different boilers will be given, together with comments which may be useful to students of the subject. Mere tables of results of individual boiler-tests are of little use until they are collated and compared with a view to discover the various causes or conditions which contributed to the results obtained.

Range of Economy found in Actual Practice.—In Donkin's "Heat Efficiency of Steam-boilers" there are fifty tables containing the results of 425 experiments on boilers of different types. The following table is a brief summary of the highest, lowest, and mean efficiencies obtained in 405 experiments with different boilers without economizers.

EFFICIENCY PER CENT.

| Type of Boiler. | Number of Experiments. | Mean of two best Results. | Lowest, one Experiment. | Mean of all Experiments. | Type of Boiler. | Number of Experiments. | Mean of two best Results. | Lowest, one Experiment. | Mean of all Experiments. |
|-----------------------------|------------------------|---------------------------|-------------------------|--------------------------|--------------------|------------------------|---------------------------|-------------------------|--------------------------|
| Water-tube* .. | 6 | 84.1 | 66.6 | 77.4 | Elephant | 7 | 70.8 | 58.9 | 65.3 |
| Locomotive . . . | 37 | 83.3 | 53.7 | 72.5 | Water-tube † . . | 49 | 77.5 | 50.0 | 64.9 |
| Lancashire . . . | 10 | 74.4 | 65.6 | 72.0 | Lancashire . . . | 40 | 73.0 | 51.9 | 64.2 |
| Two-story | 9 | 76.1 | 57.6 | 70.3 | Cornish | 3 | 65.9 | 60.0 | 62.7 |
| Two-story | 29 | 79.8 | 55.9 | 69.2 | Lancashire . . . | 107 | 79.5 | 42.1 | 62.4 |
| Dry-back | 24 | 75.7 | 64.7 | 69.2 | Dry-back | 6 | 73.4 | 54.8 | 61.0 |
| Return smoke-tube | 11 | 81.2 | 56.6 | 68.7 | Lancashire ‡ . . | 6 | 66.7 | 52.0 | 59.4 |
| Cornish | 25 | 81.7 | 53.0 | 68.0 | Elephant | 8 | 65.5 | 54.9 | 58.5 |
| Cornish | 9 | 81.0 | 55.0 | 67.0 | Lancashire . . . | 8 | 74.3 | 45.9 | 57.3 |
| Wet-back | 6 | 69.6 | 62.0 | 66.0 | Vertical | 5 | 76.5 | 44.2 | 56.2 |

* 1½-in. tubes. † 4-in. tubes. ‡ Three-flue.

About the only conclusions that may be drawn from this table are that with many different varieties of boiler there may be obtained efficiencies which are so high as to be scarcely credible; that with the same

types of boilers in other trials the results are so low that they can only be accounted for by improper firing or some other unfavorable condition; and that economy does not depend on the type of boiler. In 107 tests of Lancashire two-flue boilers the efficiencies varied from 79.5 down to 42.1 per cent, or all the way from nearly the highest possible figure down to the lowest one obtained in the whole series of tests.

In Mr. Geo. H. Barrus's book on Boiler Tests there are records of a great number of tests with different kinds of boilers, with different coals, and in different parts of the country. Selecting those tests of which complete records are given, we find the economy ranges as follows:

| Water Evaporated from and at 212° per lb. Combustible. | Number of tests Anthracite. | Number of tests Semi-bit. | Number of tests Bituminous. |
|---|--------------------------------|------------------------------|--------------------------------|
| over 12 lbs..... | .. | 6 | .. |
| 11.5 to 12 lbs..... | 2 | 6 | .. |
| 11 to 11.5 lbs..... | 10 | 5 | .. |
| 10.5 to 11 lbs..... | 20 | 3 | .. |
| 10 to 10.5 lbs..... | 11 | 5 | 1 |
| 9 to 10 lbs..... | 14 | 6 | 2 |
| 8 to 9 lbs..... | 8 | 3 | .. |
| 6 to 7 lbs..... | 1 | .. | .. |
| | 66 | 34 | 3 |

Out of 66 tests with anthracite, only two gave a result over 11.5 lbs., a figure which may be reached with any type of boiler, properly designed and set, by a good fireman using good coal. Twenty-three out of the 66 boilers gave a result below 10 lbs., or 20 per cent less than the highest figure attainable. In the semi-bituminous tests only six boilers out of 34 gave 12 lbs., a figure which may easily be obtained with any good form of boiler, properly proportioned, properly set, and properly fired.

Spence's Experiments on the Effect of Varying the Air-supply.*—

The experiments were made in 1887 with a "dry-back" type of marine boiler, 14 ft. 9 in. long, 6 ft. diameter, with 88 2½ in. smoke-tubes 5 ft. 9 in. long; heating surface, 446 sq. ft.; grate-surface, 14.6 sq. ft.; two internal furnaces, with top of grate-bars 1 ft. 3½ in. from crown of furnace. The experiments were all made with the same coal, fireman, and steam-pressure. The object of the first series, eleven tests, was gradually to increase the air-supply from 12¼ lbs. per pound of coal, an insufficient quantity, to a sufficient quantity of 17.3 lbs., 10.4 lbs. being theoretically required for complete combus-

* From Donkin's "Heat Efficiency of Steam-boilers," p. 65. Original in the Transactions of the Northeast Coast Engineers and Shipbuilders, vol. 4, 1888.

tion of the coal. Other conditions were kept nearly constant. The steam-pressure was 55 lbs. The heating value of the dry coal (Newcastle nut) was 13,620 B.T.U. per lb., and it contained from 1.2 to 3.5% ash, as shown by the boiler-tests.

The first set of experiments was made with natural draft. A second set of five tests was made with forced draft, the air per pound of coal being varied from 17.5 to 23.0 lbs.; and a third set of eight tests, also with forced draft, was made with the grate-bars lowered to 1 ft. 6½ in. below the crown-sheet, with the air-supply from 17.1 to 22.9 lbs.

The following are the principal results obtained:

| Number of Test. | Area of Grate. Sq. Ft. | Coal per Sq. Foot of Grate per Hour. Lbs. | Water Evaporated from and at 212°. | | Temperature of Gases at End of Boiler. | Efficiency.* Per cent. | Air per Pound Fuel. Lbs. |
|-----------------|------------------------|---|---|-------------------------|--|------------------------|--------------------------|
| | | | Per Sq. Ft. of Heating Surface per Hour.—Lbs. | Per Pound of Coal. Lbs. | | | |
| 1..... | 14.6 | 17.5 | 5.27 | 9.16 | 779° F. | 65.0 | 12.25 |
| 2..... | 14.6 | 18.1 | 5.5 | 9.26 | 815 | 65.7 | 13.1 |
| 3..... | 14.6 | 17.8 | 5.48 | 9.36 | 728 | 66.4 | 13.8 |
| 4..... | 14.6 | 18.6 | 5.74 | 9.28 | 768 | 65.8 | 14.0 |
| 5..... | 14.6 | 18.6 | 5.78 | 9.46 | 764 | 67.1 | 16.8 |
| 6..... | 14.6 | 18.8 | 5.95 | 9.63 | 757 | 68.2 | 16.6 |
| 7..... | 14.6 | 18.4 | 5.85 | 9.68 | 775 | 68.6 | 17.3 |
| 8..... | 14.6 | 18.5 | 6.07 | 10.01 | 748 | 71.0 | 18.2 |
| 9..... | 14.6 | 17.0 | 5.67 | 10.19 | 788 | 72.2 | 20.4 |
| 10..... | 14.6 | 17.5 | 5.93 | 10.33 | 767 | 73.2 | 17.3 |
| 11..... | 14.6 | 17.4 | 5.91 | 10.25 | 701 | 72.7 | 18.5 |

FORCED-DRAFT TESTS.

| | | | | | | | |
|---------|------|------|------|------|-------|------|------|
| 12..... | 10.1 | 42.7 | 8.79 | 9.06 | 1100° | 64.7 | 18.6 |
| 13..... | 7.5 | 40.4 | 6.5 | 9.57 | 919 | 67.8 | 26.6 |
| 14..... | 6.38 | 39.0 | 6.6 | 9.15 | 944 | 64.8 | 23.0 |
| 15..... | 8.25 | 31.1 | 5.4 | 9.43 | 872 | 66.8 | 20.7 |
| 16..... | 10.1 | 29.8 | 6.6 | 9.39 | 934 | 66.6 | 17.5 |

FORCED DRAFT—GRATE-BARS LOWERED 3 IN.

| | | | | | | | |
|---------|-----|------|-----|-------|------|------|------|
| 17..... | 7.2 | 39.5 | 6.0 | 9.41 | 760° | 66.7 | 17.1 |
| 18..... | 7.2 | 37.0 | 6.4 | 10.67 | 783 | 75.7 | 20.3 |
| 19..... | 7.2 | 37.7 | 6.3 | 10.39 | 764 | 73.6 | 20.3 |
| 20..... | 6.8 | 46.3 | 7.0 | 9.95 | 835 | 70.5 | 22.0 |
| 21..... | 9.3 | 36.3 | 7.0 | 9.29 | 834 | 65.9 | 20.0 |
| 22..... | 5.8 | 47.5 | 6.4 | 10.35 | 739 | 73.4 | 21.8 |
| 23..... | 6.2 | 36.8 | 5.4 | 10.65 | 741 | 75.5 | 22.9 |
| 24..... | 8.2 | 31.5 | 5.9 | 10.27 | 692 | 72.8 | 18.0 |

* The reported heating value, 13,620 B.T.U. per lb. dry coal, with from 1.2 to 3.5% ash, is probably much lower than the true value, and the reported efficiencies are therefore probably higher than the actual efficiencies.

The results are plotted on the accompanying diagram, Fig. 119. Studying the diagram we see that in the first set of tests, those with natural draft, there is a steady increase of efficiency as the air per pound of fuel increases from $12\frac{1}{2}$ to 18 lbs. In the second set, with forced draft, and with air-supply from 17.5 to 26.6 lbs. all the results are low, due, no doubt, to the combustion being imperfect on account of the insufficient room in the fire-box. In the third series the air-supply ranges only from 17.1 to 22.9 lbs., and the results are erratic, an air-supply of 20 lbs. per pound of coal giving both the lowest and the highest efficiency; or 65.9 and 75.7 per cent. The difference, 9.8 per cent, which is 13 per cent of the higher figure, is not accounted for by anything in the record. The lower figure was probably due to some error in the firing. The low figure in the second set of tests, 64.7 per cent, is partly accounted for by the rate of driving being much higher than in the other tests.

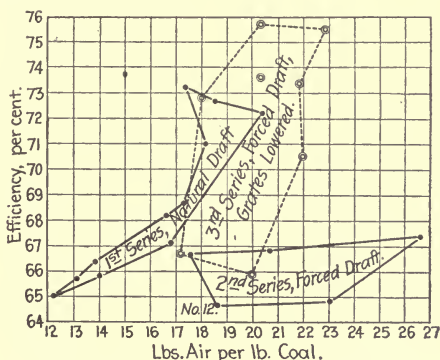

FIG. 119.—SPENCE'S EXPERIMENTS.

Results of Tests with Small Sizes of Anthracite Coal.—The table on page 384 gives the results of five tests with small sizes of anthracite coal reported by Eckley B. Coxe in *Trans. Am. Inst. Mining Engineers*, vol. xxii. 1893. All were made with the Coxe travelling grate, the first four with two Stirling water-tube boilers, and the fifth with a group of three cylinder boilers with two mud-drums underneath, set over a single furnace, with a cast-iron water-tube boiler in the flue, containing nearly as much heating surface as the cylinder boilers. The following remarks on these tests are made by Mr. Coxe:

The plant at Oneida No. 3 consists of two 150-H.P. Stirling boilers of the ordinary type to which this grate has been applied. In this case a fire-brick arch covers almost the whole of the grate and the gases from the entire grate mingle at the outlet. The result of having this fire-brick arch is to keep up an intense heat over the grate, giving a chance for most of the carbonic oxide to unite with the oxygen of the free air before the gases become cold by contact with the heated surface of the boiler. It appears probable that it will be an advantage

RESULTS OF TESTS OF PEA AND BUCKWHEAT WITH TWO TYPES OF BOILERS AND COXE TRAVELLING GRATE.

| | 1. Oneida Pea coal. | 2. Oneida No. 1 Buck- wheat.] | 3. Oneida No. 2 Buck- wheat. | 4. Oneida No. 3 Buck- wheat. | 5. Eckley No. 3 Buck- wheat. |
|---|---------------------------|---|--|--|--|
| KIND OF FUEL USED. | | | | | |
| Pounds of water evaporated from and at 212° F. per lb. dry coal.... | 8.56 | 7.94 | 8.60 | 8.65 | 8.74 |
| Pounds of water evaporated from and at 212° F. per lb. combustible | 10.14 | 10.06 | 10.57 | 11.12 | 11.10 |
| Pounds of water evaporated from and at 212° F. per hour per sq. ft. of heating surface..... | 3.70 | 3.21 | 3.13 | 3.13 | 3.06 |
| Pounds of coal per square foot of grate per hour | 13.63 | 13.58 | 11.40 | 11.34 | 9.44 |
| Average temperature of escaping gases, degrees F..... | 549 | 543 | 498 | 503 | 372 |
| Horse-power actually developed.... | 372.8 | 343 | 312.6 | 312.8 | 165 |
| Square feet heating surface per H.P. | 9.25 | 10.05 | 11.03 | 11.03 | 11.28 |
| Percentage over rated capacity.... | 24.26 | 14.33 | 4.20 | 4.28 | |
| Moisture in coal as fired..... | 2.63 | 4.06 | 8.62 | 6.53 | 4.93 |
| Per cent of ash..... | 15.60 | 20.10 | 18.71 | 22.27 | 21.3 |
| Carbon in ash, per cent..... | 15.85 | 12.35 | 9.33 | 31.90 | 29.63 |
| Pressure of steam, average..... | 139 lbs. | 134 lbs. | 133 lbs. | 124 lbs. | 94 lbs. |
| “ “ blast, in. of water..... | $\frac{3}{8}$ " | $\frac{1}{2}$ " | $\frac{5}{8}$ " | $1\frac{1}{2}\frac{1}{5}$ " | $1\frac{1}{8}$ " |
| Temperature of feed-water, average | 65 | 67 | 62 | 63 | 68 |
| ANALYSIS OF COAL. | | | | | |
| Water at 225° F..... | 2.15 | 2.00 | 2.10 | 2.05 | 2.50 |
| Volatile combustible matter..... | 5.10 | 4.90 | 5.45 | 5.42 | 5.00 |
| Ash..... | 12.55 | 17.35 | 15.50 | 12.90 | 13.97 |
| Fixed carbon..... | 80.20 | 75.75 | 76.95 | 79.63 | 78.53 |
| Specific gravity..... | 1.620 | 1.664 | 1.655 | 1.642 | 1.665 |
| SIZING TEST. | | | | | |
| Chestnut over $\frac{7}{8}$ " round mesh... .. | 8.44 | .98 | | | |
| Pea coal between $\frac{7}{8}$ and $\frac{9}{8}$ " r'd mesh | 60.65 | 6.85 | .31 | 1.50 | 1.21 |
| No. 1 buckwheat betw. $\frac{9}{8}$ " & $\frac{3}{2}$ " " | 21.70 | 57.72 | 4.76 | 4.58 | 2.60 |
| No. 2 " " $\frac{3}{2}$ " & $\frac{3}{16}$ " " | 3.68 | 28.74 | 66.57 | 17.75 | 31.94 |
| No. 3 " " $\frac{3}{16}$ " & $\frac{3}{32}$ " " | 1.40 | 2.39 | 19.87 | 45.95 | 49.56 |
| Between $\frac{3}{32}$ " & $\frac{1}{16}$ " | 4.13 | 1.49 | 2.39 | 19.79 | 6.31 |
| Dust—through $\frac{1}{16}$ " mesh (round).... | | 1.83 | 6.10 | 10.43 | 8.37 |
| | 100.00 | 100.00 | 100.00 | 100.00 | 100.00 |

to remove the heating surface of the boiler from the combustion-chamber so that the gases will not come in contact with the cooler iron surface until the carbonic oxide has been entirely burned and a thorough mingling of all the gases has taken place.

We have, we think, established one fact, and that is that the size of the coal does not materially affect the number of pounds of water

evaporated per pound of combustible.* It does affect the number of pounds of water evaporated per square foot of heating surface. The temperature at which the smaller coals burn is not as great as that developed by the larger coal, and therefore 1 sq. ft. of heating surface will not absorb as much heat when we use small coal as when we use large; but the economy (that is, pounds of water evaporated per pound of coal) appears to be about the same in all cases. Of course, the commercial value at present of No. 3 buckwheat is very much less than that of pea coal.

Dimensions and proportions: For tests Nos. 1, 2, 3, and 4, two Stirling water-tube boilers. Each boiler 4 drums, viz., one 42 ins. diam. and three 36 ins., each 105 $\frac{3}{4}$ ins. long; 155 3 $\frac{1}{4}$ -in. tubes; heating surface 1725 sq. ft.; builder's rating 150 H.P.; grate 6 ft. wide by 9 ft. 2 ins. long = 55 sq. ft.; ratio heating to grate-surface 31.4 to 1. For test No. 5, cylinder boilers with improved setting, consisting of 3 main drums 34 ins. \times 36 ft. and 2 mud-drums 34 ins. \times 20 ft. 4 ins. with 8 short connections, 4 14-in. and 4 10-in. diam.; heating surface of main drums 575 sq. ft., of mud-drums 393 sq. ft., of connections 21 sq. ft.; together with a cast-iron water-tube boiler in the flue, with tubes 2 $\frac{1}{2}$ ins. inside diameter, heating surface 873 sq. ft.; total heating surface 1862 sq. ft. Grate 7 ft. 6 ins. wide \times 9 ft. 2 ins. long = 68.75 sq. ft. Ratio of heating to grate-surface 27.¹ to 1.

Comments on the above Tests.—It appears that in test No. 1, with the pea coal, an evaporation of only 10.14 lbs. from and at 212° per lb. of combustible was obtained, as compared with 11.12 lbs. in test No. 4 with No. 3 buckwheat. The more rapid rate of driving, 3.70 lbs. per sq. ft. of heating surface per hour as compared with 3.13 lbs., is not sufficient to account for the difference, which is nearly 10 per cent. The higher temperature of the escaping gases, 549° as compared with 503°, would account for a loss of 5 per cent if the furnace temperature were 2300° in both cases, but with the same air-supply the furnace temperature should be lower with the buckwheat coal, since it contained 6.53 per cent moisture while the pea coal contained only 2.63 per cent, and the buckwheat coal, other conditions being equal, should therefore give lower economy than the pea. It is likely that the low economy in test No. 1 is due to excessive air-supply, and that a much higher result might have been obtained if the test had been repeated with a thicker bed of coal or with a better regulation of the air-supply.

Tests Nos. 4 and 5 show a very close agreement, in quality of coal, in rate of burning and of evaporation, and in economy. The great

* A different result appears to have been obtained in Mr. Barrus's tests with Stirling boilers, discussed later.

difference in these two tests is in the type of boiler, test No. 4 being with a Stirling water-tube boiler with a fire-brick arch furnace, and No. 5 with a cylinder boiler 34 ft. long supplemented by a cast-iron water-tube boiler in the flue. The advantage of the fire-brick arch in securing complete combustion of the volatile gases distilled from the coal and those formed by decomposition of its moisture is probably equalized by the long travel of the gases, 34 ft. under the cylinder boilers, which would also tend to secure complete combustion. The absorptive capacity of the heating surface of the two boilers seems to be equal, confirming the statement that the economy of a boiler does not depend upon the type, but upon the conditions under which it is operated.

Tests of Stirling Boilers with Anthracite Coal.*—In 1894 Mr. Geo. H. Barrus made a series of nine tests on two Stirling water-tube boilers at two collieries near Wilkes-Barre, Pa. From the reports of these tests the table and diagram on pages 387 and 388 have been prepared. Tests Nos. 1 and 2 inclusive were made on a 125-H.P. boiler at No. 5 shaft of the Lehigh and Wilkes-Barre Coal Co., and Nos. 8 and 9 were made on a 150-H.P. boiler at the Dorrance colliery of the Lehigh Valley Coal Co. The rating of the boilers is on the basis of $11\frac{1}{2}$ sq. ft. of heating surface to a horse-power. Forced draft was supplied by McClave steam-blowers. The coal used in the several tests differed in size and quality. The sizes were determined by passing samples through and over screens of different meshes and weighing the portions thus separated. The coal used in five of the tests was as follows, the figures being given in percentages:

| Sizes of Screen. | | Over $\frac{1}{8}$ in. | Through $\frac{1}{8}$ in. | Through $\frac{1}{4}$ in. | Through $\frac{3}{8}$ in. | Through $\frac{1}{2}$ in. |
|------------------|--------------------------------|------------------------|---------------------------|---------------------------|---------------------------|---------------------------|
| Test No. 3. | No. 2 buckwheat | 25 | 45 | 19 | 11 | |
| " " | 6. Culm, No. 5 shaft | | 3 | 11 | 86 | |
| " " | 7. Culm, No. 4 shaft | 18 | 24.1 | | 57.9 | |
| " " | 8. No. 2 buckwheat | | 2.5 | 65 | | 32.5 |
| " " | 9. No. 2 buckwheat | | 10.7 | 67 | | 22.3 |

A Study of the Results of the Stirling Tests.—For comparing the results of these tests they have been plotted on the accompanying diagram, Fig. 120, showing the relation of the water evaporated per pound of combustible, or the economy, to the rate of driving, or the

* From *Mines and Minerals*, December, 1897.

TESTS OF STIRLING BOILERS AT ANTHRACITE COAL-MINES.

| Number of Test..... | 1 | 2 | 3 | 4 | 5 |
|---|-------------|--|-------------|-------------|-------------|
| Test for capacity or economy..... | Capacity. | Capacity. | Economy. | Economy. | Capacity. |
| Kind of coal..... | Buck-wheat. | Culm $\frac{3}{4}$, Buck-wheat $\frac{1}{4}$. | Buck-wheat. | Buck-wheat. | Buck-wheat. |
| Ash and clinker, per cent..... | 12.0 | 25.9 | 12.0 | 12.0 | 12.6 |
| Area of grate, sq. ft..... | 45 | 45 | 45 | 38 | 38 |
| Ratio of grate to heating surface, 1 to | 31.9 | 31.9 | 31.9 | 37.8 | 37.8 |
| Draft-suction in stack, ins. of water | .16 | .16 | .16 | .16 | .16 |
| Draft-pressure in ash-pit, ins. | 1.00 | 1.00 | 0.20 | 0.30 | 1.00 |
| Steam used to run blowers, estimated H.P..... | 12.9 | | 7.2 | 6.7 | 13.3 |
| Coal burned per hour per square foot of grate, lbs..... | 29.3 | 14.55 | 13.17 | 14.84 | 28.28 |
| Water evaporated per hour per square foot heating surface, lbs. | 6.04 | 2.74 | 3.61 | 3.33 | 6.06 |
| Horse-power developed, H.P. | 289.3 | 131.3 | 172.8 | 159.6 | 290.2 |
| H.P. above boiler's rating, per cent | 131 | 5.0 | 38.2 | 27.7 | 132 |
| Average temperature of flue-gases, degrees F. about | 800 | 439 | 500 | 485 | 684 |
| Water evaporated from and at 212° per pound of coal, lbs..... | 7.563 | 6.910 | 9.955 | 10.075 | 9.310 |
| Water evaporated from and at 212° per pound of combustible..... | 8.594 | 9.325 | 11.324 | 11.449 | 10.052 |
| Number of Test..... | 6 | 7 | 8 | 9 | |
| Test for capacity or economy..... | Capacity. | Capacity. | Capacity. | Economy. | |
| Kind of coal..... | Culm No. 5. | Culm No. 4. | Buckwheat. | Buckwheat. | |
| Ash and clinker, per cent..... | 15.1 | 20.7 | 15.6 | 13.9 | |
| Area of grate, sq. ft..... | 45 | 45 | 47.3 | 47.3 | |
| Ratio of grate to heating surface, 1 to | 31.9 | 31.9 | 36.5 | 36.5 | |
| Draft-suction in stack, ins. of water | .16 | .16 | .12 | .10 | |
| Draft-pressure in ash-pit, ins. | 0.90 | 1.00 | 1.50 | 0.87 | |
| Steam used to run blowers, estimated H.P..... | 8.7 | 12.3 | 13.2 | | |
| Coal burned per hour per square foot of grate, lbs..... | 10.66 | 17.63 | 23.82 | 18.16 | |
| Water evaporated per hour per square foot heating surface, lbs. | 2.81 | 3.79 | 4.8 | 3.92 | |
| Horse-power developed, H.P. | 134.8 | 181.6 | 275.9 | 225.2 | |
| H.P. above boiler's rating, per cent | 7.8 | 45.3 | 83.9 | 50.1 | |
| Average temperature of flue-gases, degrees F. about..... | 462 | 543 | 560 | 524 | |
| Water evaporated from and at 212° per pound of coal, lbs..... | 9.122 | 7.889 | 8.437 | 9.046 | |
| Water evaporated from and at 212° per pound of combustible..... | 10.745 | 9.949 | 9.996 | 10.495 | |

water evaporated per square foot of heating surface per hour. For further comparison there are also plotted two dotted lines representing the maximum and the average results of tests with anthracite coal given in Mr. Barrus's book on "Boiler-tests," together with a line representing the maximum results obtained in the boiler-tests at the Centennial Exhibition. As the Centennial tests were made with egg coal of excellent quality and under the most favorable conditions, it is to be expected that their maximum results will be considerably above those obtained with buckwheat coal. Of the tests with buckwheat coal given in the above table, Nos. 3, 4, and 5 lie close to the line of Mr. Barrus's maximum results, Nos. 8 and 9 are near the line of his

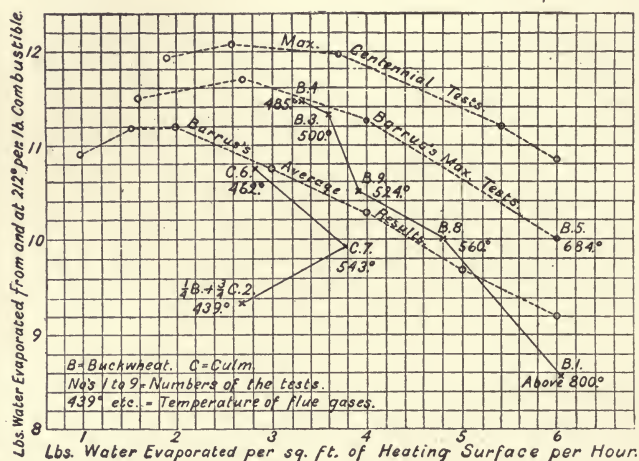

FIG. 120.—TESTS OF STIRLING BOILERS WITH ANTHRACITE BUCKWHEAT AND CULM COMPARED WITH TESTS RECORDED IN BARRUS ON "BOILER-TESTS" AND WITH THE CENTENNIAL TESTS.

average results, and No. 1 is considerably below the average line. Of the tests with culm, No. 6 is a little, and No. 7 considerably, below the average line, while test No. 2, with one-fourth buckwheat and three-fourths culm, is far below the average line. In explanation of these varied results we find on referring to Mr. Barrus's report that in tests Nos. 1, 2, and 3 the shaking grate-bars had their air-spaces, unevenly adjusted, causing an uneven distribution of air through the bed of coal. This may account to some extent for the low results of tests Nos. 1 and 2, but it does not seem to have had much effect in test No. 3, the result of which is very high. The three tests were made on three consecutive days, and possibly in test No. 1 the firing

was done unskillfully, for the temperature of the gases was beyond the range of the thermometer, or over 800°, and during the whole run the flame from the coal extended into the stack and during part of the time flame could be seen issuing from the top of the stack. Over-driving of the boiler does not sufficiently account for this, for in test No. 5 with the same coal (or nearly the same) as in No. 1 and with the boiler developing as great a horse-power the temperature of the flue-gases averaged only 684°. Test No. 2, with three-fourths culm and one-fourth buckwheat, gave a result over 12 per cent below test No. 6, all culm, the boiler in the two tests being driven at the same rate. This loss of 12 per cent may have been due to mal-adjustment of the grate-bars, but it was probably partly due to the mixing of two kinds of coal, which is generally believed to give poor results with anthracite coal, the fine sizes choking up the interstices between the larger sizes, and doing this irregularly on different portions of the grate, causing irregular burning, with excess of air-supply through some portions and deficient supply through others.

Tests Nos. 1 and 5, with the same coal and the same rate of driving of the boiler, show a remarkable difference of economy, the former being over 14 per cent below the latter. The differences of the conditions of these tests which may have caused the difference in results were: (1) Larger grate-surface in No. 1 than in No. 5; (2) bad adjustment of the air-spaces in No. 1; (3) possibly, unskilled firing in No. 1. The larger grate-surface in No. 1 is not likely to have been the cause, for test No. 3 with the same large grate-surface gave practically as high a result as No. 4, with the reduced grate-surface. The difference in tests Nos. 1 and 5 is instructive in showing what a wide difference in results is possible in the same boiler, with the same coal and the same rate of driving, due to what may appear to be slight causes, such as difference in the air-spaces through the grate-bars or in the skill of the firemen.

Tests Nos. 8 and 9 fall considerably below the line of tests Nos. 3, 4, and 5. These tests were made on a different boiler of the same make, but there was probably not any difference in the details of construction of the boiler or setting which would account for the difference in results. There was, however, considerable difference in the coal, as shown by the percentage of ash and by the table of sizes. The coal used in Nos. 8 and 9 was finer in size than that used in test No. 3, 66 per cent of it going through a $\frac{1}{4}$ -in. screen, while in the coal of test No. 3 only 30 per cent went through $\frac{1}{4}$ in. The coal of tests

Nos. 8 and 9 was of an intermediate size between that of test No. 3 and culm, and the diagram shows that the results given by it are also intermediate between those of the other coals.

The results plotted in the diagram are the pounds of water evaporated per pound of combustible and not per pound of coal. Since the combustible of all the coals used in these tests is practically of identical quality, it might be expected that all the coals would give the same result per pound of combustible, and that results per pound of coal would correspond, except as they are influenced by different percentages of moisture and ash. The plotted results show, however, that although the combustible portion of all the coals may be identical in quality, it gives different results when it is contained in coal of different sizes. Tests Nos. 3, 4, and 5, with the largest size of buckwheat coal, give the best results, test Nos. 8 and 9 with finer-sized buckwheat give results much lower, and tests Nos. 6 and 7, with culm, still lower results. Tests Nos. 1 and 2, both exceptionally low, may be neglected from the comparison, as they were influenced by unfavorable conditions, such as mixing of sizes and uneven adjustment of the air-spaces. The best results obtained with the large-sized buckwheat coal, also, are from 5 to 7 per cent below the best results obtained in the Centennial tests with egg coal.

A reasonable theory to account for the regular decrease in evaporation per pound of combustible as the size of the coal is made finer seems to be the following: When egg or other large-sized coal is used, a thick bed of it is carried on the grate, through which the air passes with comparative uniformity. The lumps of coal burn away slowly, from the surface; fresh coal is fired at long intervals of time, and the condition of the fire is always nearly the same. If the draft and the thickness of the bed are properly related to each other, and the boiler is well designed, the maximum economy possible with the coal may be obtained. With finer-sized coals, however, a thinner bed must be carried, relatively to the force of draft; air-holes are more likely to be formed in the bed, causing too great a supply of air to pass through some portions while an insufficient supply is furnished to other portions. Fresh coal is fired at frequent intervals, involving frequent openings of the doors and inrush of cold air; and the fresh coal for a short time after firing, being small in size, is apt to clog the fire and obstruct the air-supply, causing the burning of the coal to carbonic oxide instead of carbonic acid. The bed of coal being thin and the draft strong, if the fireman leaves the fire unattended to for a minute

or two after it is time to fire fresh coal, air-holes will form rapidly, while with egg coal a period of five minutes makes but little difference.

Mr. Barrus gives in his reports of these tests a statement of the "efficiency," or ratio of the heat absorbed by the boiler to the heating value of the coal, in the several economy tests, as follows:

| Test No. | 4 | 6 | 7 | 9 |
|---|-------------|-------------|-------------|-------------|
| Coal. | Buck-wheat. | Culm No. 5. | Culm No. 4. | Buck-wheat. |
| 1. Heating value of coal per lb. of combustible, B.T.U..... | 13,877 | 13,985 | 14,044 | 14,157 |
| 2. Water evaporation from and at 212° per lb. combustible, lbs..... | 11.449 | 10,745 | 9,949 | 10,495 |
| 3. Heat utilized (line 2 × 966) B.T.U.... | 11,080 | 10,360 | 9,611 | 10,138 |
| 4. Efficiency (line 3 ÷ line 1)..... | 79.6 | 74.2 | 68.4 | 71.6 |

The maximum range of variation of the heating values of the four coals is only 270 B.T.U. per pound, or less than 2 per cent. It is probable that all of these heating values are too low, due to imperfection of the calorimeter by which they were determined, or possibly to the fact that the samples used were not thoroughly dry (the heating value of anthracite calculated from the analysis is usually about 14,800 B.T.U. per pound of combustible), and that the efficiencies recorded are consequently too high, but the figures give relative values which may be accepted as correct. The reported efficiency in test No. 4 is 79.6 per cent and that in No. 7 only 68.4 per cent, although the boiler was driven at practically the same rate in the two tests. The falling off in efficiency of $(79.6 - 68.4) \div 79.6$, over 14 per cent, shows how much poorer a fuel practically the culm is than buckwheat, per pound of combustible, although the combustible itself in the two coals is of identical quality. The practical value of culm per pound of coal is further reduced by the greater percentage of ash and moisture it usually contains, as compared with buckwheat.

The results of these tests show that the efficiency of any given steam-boiler is not a constant quantity, that it varies not only with the rate of driving, but with the quality of the coal and even with the size of coal of the same quality.

Another useful lesson to be learned from these tests is in regard to the capacity. The three capacity-tests with buckwheat coal, Nos. 1, 5, and 8, gave a horse-power, respectively, 131, 132, and 84

per cent above the rated power of the boiler, and the highest economy was obtained when the boiler was driven 28 per cent above its rating. Whether any higher economy could have been obtained with this coal if the boiler had been driven at a lower rate cannot be said, for no test was made at a lower rate with buckwheat coal. The three capacity-tests with culm, Nos. 4, 6, and 7, gave respectively 5, 8, and 45 per cent above rating, although the force of draft was practically the same as in the tests with buckwheat coal. It appears then that a boiler will not develop the same horse-power from culm as from buckwheat unless the grate-surface or the draft, or both, are increased.

Comparative Trials on Three Two-flue Boilers with Pittsburg Coal.—These tests were made by the Shoenberger Steel Co., Pittsburg, Pa., in 1897, to determine the efficiency of the American Underfeed Stoker as compared with flat grates when applied to two-flue boilers.

Grate-surface, total of three boilers, 90 sq. ft.; water-heating surface, 1225 sq. ft.; ratio of heating to grate-surface, 13.6.

| | Hand-fire. | American Stoker. | |
|---|-------------|------------------|--------------|
| | | Economy. | Capacity. |
| Duration, hours..... | 8 | 8 | 7 |
| Steam-pressure by gauge, pounds..... | 101.2 | 101.09 | 99.24 |
| Temperature of escaping gases, °F..... | 816.3 | 735.1 | 828 |
| “ “ feed water, °F..... | 149.9 | 155.9 | 171.3 |
| Size of coal..... | Run of Mine | River Slack | River Slack |
| Quantity of coal consumed, pounds..... | 13,500 | 10,500 | 12,300 |
| Refuse, per cent..... | 12 | 9.49 | |
| Coal per square foot of grate per hour, lbs. | 18.7 | 14.5 | 19.4 |
| Total water actually evaporated, pounds. | 82,160 | 92,140 | 100,917 |
| Water per hour, equivalent from and at 212° F., pounds..... | 11,344 | 12,653 | 15,600.3 |
| Water per hour, per square foot heating surface, pounds..... | 9.26 | 10.33 | 12.73 |
| Evaporation, apparent per lb. of coal, lbs. | 6.086 | 8.775 | 8.204 |
| Evaporation, from and at 212° F., lbs.... | 6.72 | 9.640 | 8.877 |
| Horse-power developed..... | 327.8 | 360.7 | 452 |
| Builders' rating..... | 120 | 120 | 120 |
| Ratio of H.P. developed to builders' rating..... | 2.73 | 3.05 | 3.7 |
| Heating surface per horse-power, sq. ft. | 3.72 | 3.34 | 2.7 |
| Per cent increase of capacity by the use of stoker..... | | 11.6 | 37.5 |
| Per cent increase evaporation per pound of coal as shown by the American Stoker over hand-firing..... | | 44.5 | 32 |
| Efficiency assuming the heating value per lb. combustible at 15,000 B.T.U., per cent..... | 43.3 | 62.1 | 57.2 |

The results of these tests are of interest for many reasons. The hand-fired test is fairly representative of what was every-day practice with the two-flue boiler in the Pittsburg iron-mills until the general introduction of water-tube boilers and improved furnaces and methods of firing. In this test the boiler was driven at 2.73 times its rated power, the flue-gases escaped at 816° F., and the calculated efficiency is only 43.3 per cent. In the "economy" test, so-called, with the stoker, the boiler was driven at a still higher rate of evaporation, viz., 3.05 times its rated power, although less coal was burned under it, the temperature of the flue-gases was only 735°, and the efficiency was brought up to 62.1°. This is a very high efficiency for such a rate of driving, but it could no doubt have been brought up to 72 per cent if the rate of driving had been reduced about half and the temperature of the gases had thereby been reduced to below 500°. In the capacity-test with the stoker, still more coal per hour was burned than in the hand-fired test, and the rate of driving was the extraordinary figure of 12.73 lbs. from and at 212° per sq. ft. of heating surface per hour, or 3.7 times the rated power, yet the temperature of the flue-gases, 828°, was only a trifle higher than in the hand-fired test, while the efficiency, 57.2 per cent, was very much higher. The results of the test show the advantage gained by the short flame of very high temperature produced by the American stoker with its forced blast, over the long smoky flame of comparatively low temperature produced in the ordinary furnace by hand-firing and natural draft.

Applying to the results of these tests the "criterion" formula given in the chapter on Efficiency of Heating Surface, page 221, viz.,

$$a = \frac{K - 4.8t}{966(1 + 0.1S/W) - E_a} \div \frac{23.04}{(K - 4.8t)} \frac{W}{S},$$

we obtain, taking K as 15,000

| | | | |
|-----|--------------|-------|-------|
| for | $W/S = 9.26$ | 10.33 | 12.73 |
| | $E_a = 6.72$ | 9.64 | 8.877 |
| | $a = 457$ | 244 | 234 |

The last two values of a , 244 and 234, represent excellent performance. The high value of a , 457, represents poor performance, which is accounted for by incomplete combustion due to an unsuitable furnace.

Test of One of the Babcock & Wilcox Boilers for the U. S. Cruiser "Cincinnati."—In the Annual Report of the Chief of Bureau of Steam Engineering, for 1900, there is published a report of a test made on

one of the new boilers built by the Babcock & Wilcox Company for the *Cincinnati*, by a board composed of Lieutenant Commander A. B. Willits and Lieutenant B. C. Bryan, U. S. Navy. This test was made June 15 to 22, 1900, at the works of the builders, Elizabethport, N. J., and the following synopsis includes the most important data obtained:

Description of Boiler and Appurtenances.—The boiler is composed entirely of wrought steel, the point of difference between it and the older type of this make of boiler being in the arrangement of baffle-plates (as shown in the sectional view, Fig. 106, p. 276), which compel the products of combustion to pass three times across the tubes before entering the uptake. The small tubes are 2 ins. outside diameter, while the bottom tube in each section or element is 4 ins. outside diameter.

BOILER DATA.

Diameter of top drum, 42 ins. (inside).

Length of top drum, 12 ft.

Tubes: Number, 526; 2 ins. outside diameter; length, 8 ft. Also 40; 4 ins. outside diameter; length, 8 ft. $5\frac{1}{2}$ ins.

Grate-surface: Length, 6 ft. $8\frac{1}{2}$ ins.; width, 9 ft. $5\frac{1}{2}$ ins.; area, 63.25 sq. ft.

Grate-surface reduced to 5 ft. 6 ins. length, 52 sq. ft. area, in tests Nos. 5 and 6.

Heating surface: Area, 2640 sq. ft.; ratio to grate, 41.74: 1.

Smoke-pipe: Area, 7.876 sq. ft.; height, 48 ft. above grate; ratio to grate, 1: 8.03.

Weight of boiler and all fittings except uptakes and smoke-pipe:

| | |
|--|--------|
| Without water, lbs..... | 53,304 |
| With water, 5 ins. in glass; steam at 215 lbs., lbs..... | 62,803 |
| Total weight per sq. ft of grate-surface, lbs..... | 992.9 |
| Total weight per sq. ft. of heating surface, lbs..... | 23.79 |
| Weight of air-heater and ducts, lbs..... | 5,320 |

Blower fan: Sturtevant; diameter, 60 ins.; driven by belt from shop engines.

Area of blower inlet, 9.62 sq. ft.; outlet, 6.89 sq. ft.

Air-heater: Two-pass; 3-in. tubes. Area of surface, 495 sq. ft.

The boiler was erected in a wooden structure built especially for the test and having the following dimensions: Length, 29 ft. 2 ins.; width, 17 ft. $2\frac{1}{2}$ ins.; height, 21 ft. This was made as nearly air-tight as possible, but contained several windows that could be opened or closed to regulate the amount of draft-pressure. The blower was driven by belting from the main shop engines and ran continually. The air-heater consisted of 210 3-inch tubes 3 ft. long, spaced 4 ins. from centre to centre one way, and 5 ins. the other way. A vertical division-plate divided the tubes into two separate sets or nests, and a horizontal baffle-plate extended across from the outside of each nest to within 12 ins. of the division-plate. When the heater was in use, the air from the air-tight fire-room entered at the top, passed once across the tubes over the baffle-plate, and back under same to outlets leading to back of ash-pit, the front ash-pit doors being closed. When the air-heater was not to be used, the gases were by-passed by a damper, and the air entered the ash-pit through the front, the doors thereto being removed.

Description and Object of Tests.—Seven tests were made in all. Six of these consisted of three pairs in which the two tests of each pair were under similar conditions in every way except that of using the air-heater, one being with and the other being without this heater, in order to define the economy due to its use. The last or seventh test was for the maximum consumption, and was made without the air-heater and with full grate. Two pairs of tests, one at a consumption of about 20 lbs. of coal and the other at about 35 lbs. of coal per square foot of grate per hour, were made with the full grate service in use. These tests will be found in tables of results numbered 1, 2H, 3H, 4, the letter H signifying that the air-heater was in use during the tests. Tests 1 and 2H were of eight hours' duration, and tests 3H and 4 were of six hours' duration. The grate-surface was then reduced to 52 sq. ft. by a course and a half of bricks, seven courses in height, at back of furnace, and tests Nos. 5 and 6H, lasting four hours each, were made, burning about 50 lbs. of coal per sq. ft. of grate per hour. The bricks were then removed from the furnace and test No. 7, lasting three and one-third hours, was made, burning nearly 60 lbs. of coal per sq. ft. of grate per hour. The data and results of these tests will be found in the accompanying tables.

Coal and Firing.—The coal used was Pocahontas coal from Flat Top Mine. It contained considerable slate and clinkered badly. On tests Nos. 1 and 2H run-of-mine coal was used; on tests Nos. 3H, 4, 5, and 6H the coal was screened, using a screen with a 1-inch mesh. On test No. 7 the screenings from the former tests were run over a $\frac{3}{8}$ -inch mesh screen, and the coal thus screened was mixed with the screened coal used in other tests. The firing was good and very regular. Two alternate doors were fired in rapid succession. The other two sections of fires, in wake of the other two doors, were then levelled with a hoe, then sliced through the slicing door, and then coaled, the average time between coalings of the same two furnaces being from eight to ten minutes. The furnace doors were open about twenty-five seconds when coaling and about ten seconds in levelling. The coal made comparatively little smoke except when firing or working fires. The data in regard to smoke were taken by using Ringelmann charts.

Description of Apparatus.—The water was weighed in two tanks, each supported on a platform scale, and run into a third tank below, from which the feed-pumps drew water. All pipes were above ground and in plain sight, and wherever connected to other piping or boilers, plugs were left out of T connections to show that there was no leakage. The gross and tare of each tank was taken, and the temperature was taken at the lower tank just as each upper tank drained into it. The feed-water was heated by steam injection before entering the weighing-tanks.

The coal was weighed in barrows on platform scales in the fire-room and dumped on the floor. The time was taken when each lot of barrows were fired.

A sample shovelful of coal was taken from each lot of barrows and thrown into a barrel, and from this, mixed and quartered, the final samples for analyses, calorimeter and moisture determinations were

ANALYSES OF WASTE GASES MADE DURING TESTS OF U. S. S.
"CINCINNATI" BOILER, ELIZABETHPORT, N. J., JUNE, 1900.

| Date. | Time. | Condition of fire when sample was taken. | CO ² | O | CO | Pounds dry gas per Pound Carbon. |
|---------|--------------------------------|---|-----------------|-------|-------|----------------------------------|
| 1900. | | | | | | |
| June 15 | 4.58 | | 15.2 | 3.3 | 1.0 | 16.8 |
| | 5.15 | | 14.3 | 3.0 | 2.0 | |
| | 5.30 | Just before firing..... | 13.0 | 6.5 | 0.0 | |
| | 5.55 | One minute after firing..... | 12.5 | 6.7 | 0.8 | |
| | 6.16 | Just after raking..... | 14.3 | 3.7 | 1.0 | |
| | 6.27 | Two minutes after firing..... | 12.7 | 6.6 | 0.7 | |
| | 7.05 | Three minutes after raking and just before firing..... | 16.0 | 2.0 | 2.0 | |
| | Average..... | 14.0 | 4.5 | 1.1 | | |
| June 16 | 11.45 | | 13.4 | 6.4 | 0.0 | 19.1 |
| | 12.50 | Just after firing..... | 12.0 | 5.0 | 1.0 | |
| | 1.50 | Just after slicing..... | 12.0 | 6.6 | 0.2 | |
| | 3.50 | Just after slicing..... | 13.2 | 4.8 | 0.7 | |
| | Average..... | 12.7 | 5.7 | 0.5 | | |
| June 18 | 11.25 | One-half minute after firing..... | 12.3 | 3.4 | 2.7 | 17.3 |
| | 12.40 | While slicing..... | 14.2 | 4.0 | 0.1 | |
| | 12.50 | Just after slicing..... | 12.5 | 4.3 | 1.2 | |
| | 12.58 | Just before slicing..... | 13.0 | 4.0 | 3.4 | |
| | 1.03 | One minute after firing..... | 13.5 | 5.4 | 0.2 | |
| | Average..... | 13.1 | 4.2 | 1.5 | | |
| June 19 | 10.10 | While slicing..... | 15.0 | 3.2 | 1.2 | 18.8 |
| | 10.25 | While slicing (all samples except 11 o'clock collected through $\frac{3}{4}$ -inch iron pipe),... | 13.8 | 5.2 | 0.6 | |
| | 10.28 | Just after raking..... | 14.4 | 3.1 | 0.9 | |
| | 10.35 | One minute before firing..... | 13.2 | 5.6 | 0.4 | |
| | 11.00 | While slicing (sample collected through glass tube)..... | 13.0 | 5.6 | 0.6 | |
| | 2.20 | Just after raking..... | 10.2 | 8.3 | 0.5 | |
| | 2.40 | Just after firing..... | 10.2 | 9.0 | 0.3 | |
| | Average..... | 12.8 | 5.7 | 0.6 | | |
| June 20 | 10.25 | While slicing..... | 13.5 | 5.7 | 0.0 | 20.6 |
| | 11.00 | While slicing..... | 11.2 | 8.4 | 0.3 | |
| | 11.04 | Just after firing..... | 10.4 | 8.1 | 0.5 | |
| | 11.13 | Two minutes before raking..... | 9.2 | 9.9 | 0.0 | |
| | 12.25 | Just after raking..... | 12.1 | 5.4 | 0.7 | |
| | 12.36 | Just after raking..... | 14.2 | 4.0 | 0.8 | |
| | Average..... | 11.8 | 6.9 | 0.4 | | |
| June 21 | 11.00 | Just after raking..... | 15.7 | 4.6 | 0.1 | 17.3 |
| | 11.03 | One minute before raking..... | 13.0 | 6.0 | 0.0 | |
| | 11.13 | Just after firing..... | 15.4 | 3.0 | 0.6 | |
| | 11.50 | Just after raking..... | 13.6 | 5.6 | 0.1 | |
| | 11.55 | One minute before raking..... | 13.0 | 5.3 | 0.4 | |
| | 11.59 | Just before raking..... | 16.0 | 4.2 | 0.0 | |
| | Average..... | 14.5 | 4.8 | 0.2 | | |
| June 23 | 11.21 | Two minutes before firing..... | 14.3 | 4.2 | 1.1 | 18.6 |
| | 11.45 | Two minutes before firing..... | 11.0 | 9.0 | 0.0 | |
| | 12.38 | Just before levelling and firing..... | | | | |
| | 2.26 | Just after firing..... | 11.8 | 7.9 | 0.4 | |
| | 2.30 | Just after firing..... | 13.3 | 4.2 | 1.0 | |
| 2.43 | Two minutes before firing..... | 14.2 | 3.8 | 1.0 | | |
| | Average..... | 12.9 | 5.8 | 0.7 | | |
| June 25 | 10.16 | Just before firing..... | 15.3 | 4.1 | 1.0 | 18.5 |
| | 10.21 | One minute before firing..... | 13.0 | 6.0 | 1.0 | |
| | 11.10 | Just after levelling..... | 13.7 | 6.6 | 0.3 | |
| | 11.13 | Just after firing..... | 14.0 | 5.2 | 0.8 | |
| | 11.47 | Just after firing..... | 9.0 | 11.2 | 0.3 | |
| | Average..... | 13.0 | 6.6 | 0.7 | | |

taken. The gases for analyses were drawn from near the centre of the base of smoke-pipe by means of a pipe inserted therein connected with an aspirator and small Orsat instrument.

All draft-pressures were taken outside the building, pipes being led there from the different places where pressure-determinations were required.

Temperatures were taken at the back and front of uptake just above the heater; in front by a mercurial pyrometer, and at the back by a metallic pyrometer. When the air-heater was used the temperature was taken in addition just below the heater by means of a mercurial pyrometer.

The moisture in the steam was determined by a Barrus universal calorimeter. The steam was found practically dry in all cases. The steam was partly used in the shop and partly blown off into the atmosphere, the pressure being controlled by regulating a small stop-valve by hand.

Measurement of Water in Boiler, and Time of Getting Up Steam.—Before making test No. 6H, on June 21, all water was drained from the boiler and the contents of boiler noted for each 1-inch mark of the water-gauge, with the following results:

| Height of water in gauge. | Total water. | Difference. | Height of water in gauge. | Total water. | Difference. |
|------------------------------|-----------------|-------------|------------------------------|-----------------|-------------|
| <i>Inches.</i> | <i>Pounds.</i> | | <i>Inches.</i> | <i>Pounds.</i> | |
| 0 | 9,312 | | 5 | 10,368 | 231 |
| 1 | 9,498 | 186 | 6 | 10,672 | 304 |
| 2 | 9,662 | 164 | 7 | 10,943 | 271 |
| 3 | 9,912 | 250 | 8 | 11,175 | 232 |
| 4 | 10,137 | 225 | | | |

Fires were started in the boilers with light wood and blower in use at 9.40 A.M. Temperature of water in boiler, 72 degrees; height in glass, 1 inch.

The following is a record of time and pressures or temperatures:

| Time Elapsed. | | Steam Pressure. | Time Elapsed. | | Steam Pressure. |
|---------------|------|-----------------|---------------|------|-----------------|
| Min. | Sec. | | Min. | Sec. | |
| 0 | | Fires started | 11 | | 125 pounds |
| 5 | | Steam formed | 11 | 30 | 155 " |
| 6 | 30 | 25 pounds | 11 | 55 | 175 " |
| 8 | | 45 " | 12 | 20 | 195 " |
| 9 | | 65 " | 12 | 40 | 215 " |
| 10 | | 85 " | | | |

An examination of the boiler after this test showed no injury or change in its condition in any respect.

Tests of a Thornycroft Boiler.—Prof. A. B. W. Kennedy, in Proc. Inst. C. E., vol. xcix. p. 57, 1890, reports the results of four tests of a Thornycroft boiler. The principal figures are the following:

| Trial No. | 1 | 2 | 3 | 4 |
|--|-------|-------------|-------|-------|
| Heating surface, sq. ft. | 1837 | 1837 | 1837 | 1837 |
| Grate-surface " " | 26.2 | 30 | 30 | 26.2 |
| Ratio H.S. to G.S. | 70.1 | 61.2 | 61.2 | 70.1 |
| Steam-pressure, lbs. | 182 | 171 | 149 | 180 |
| Temperature of air. | 69 | 70 | 60 | 62 |
| Coal per sq. ft. of grate per hr., lbs. | 7.74 | 18.60 | 29.80 | 66.80 |
| Water per sq. ft. of H.S. per hr., lbs. | 1.24 | 3.20 | 4.70 | 8.50 |
| Temperature of gases in chimney. | 421 | 540 | 610 | 777 |
| Evaporation from and at 212° per lb. of coal.. | 13.4 | 12.48 | 12.00 | 10.29 |
| Efficiency of boiler | 86.8 | 81.4 | 78.2 | 66.6 |
| Analyses of gases, mean : | | | | |
| Carbon dioxide, CO ₂ | 11.74 | — | 11.68 | 12.60 |
| Carbon monoxide, CO..... | 0.10 | — | 0.62 | 2.30 |
| Oxygen..... | 7.71 | — | 7.41 | 4.45 |
| Nitrogen, by difference | 80.45 | — | 80.29 | 80.65 |
| Air used per lb. fuel, lbs..... | 18.14 | (est. 17.8) | 17.4 | 17.2 |
| Heat balance : | | | | |
| Heat absorbed by boiler..... | 86.8 | 81.4 | 78.2 | 66.6 |
| " lost in chimney-gases..... | 10.8 | 15.0 | 16.5 | 20.3 |
| " lost by formation of CO..... | 0.5 | 3.6 | 5.0 | 9.2 |
| " lost by radiation and unaccounted for | 1.9 | | | |
| | 100.0 | 100.0 | 100.0 | 100.0 |
| Analysis of the coal : | | | | |
| Moisture..... | | | | 0.96 |
| Ash..... | | | | 2.19 |
| Carbon | | | | 87.76 |
| Hydrogen..... | | | | 4.11 |
| Oxygen, nitrogen, and sulphur..... | | | | 4.98 |
| | | | | 100.0 |

Heating value of the coal by Prof. Kennedy's calculation from the analysis: 14,900 B.T.U. per lb.; by direct calorimetric determination, 15,450 B. T. U. per lb.

Comments on the Thornycroft and the Babcock & Wilcox Tests.—

By the use of formula (16), p. 220, viz.,

$$a = \left[\frac{K - tcf}{966(1 + RS/W)} - E_a \right] \div \frac{c^2 f^2}{(K - tcf)} \frac{W}{S};$$

the value of *a*, the coefficient of performance, has been calculated for each of the tests of the Thornycroft and the Babcock & Wilcox boilers, of which the records are given above. For the Thornycroft tests *K*, the heating value of the coal has been taken at 15,200 per lb., as the value per pound of combustible is not given in the record, and *E_a* is taken as the evaporation per pound of coal. *R*, the factor for radiation, is taken at the low figure of 0.05, since the boiler seems to have been unusually well protected from loss by radiation; and *t*, the temperature of the steam above the atmospheric temperature, has been taken at 300°. For the Babcock & Wilcox tests the value of *K* is taken as 15,750, the average heating value per pound of combusti-

ble of good Pocahontas coal. The value of t is taken as the difference between the temperature of the steam and the temperature of the air entering the ash-pit. It ranges from 289.9 in test No. 1 down to 132.1 in test No. 6H. R is taken at 0.1.

The values of a thus calculated, together with other data of the test, for reference, are given below.

THORNYCROFT TESTS.

| | | | | |
|------------------------------------|---------|-----------|-------|-------|
| Rate of driving, W/S | = 1.24 | 3.2 | 4.7 | 8.5 |
| Evaporation, E_a | = 13.4 | 12.48 | 12.00 | 10.29 |
| Efficiency, %..... | 86.8 | 81.4 | 78.2 | 66.6 |
| Lbs. dry gas per lb. C., f | = 21.24 | [est. 21] | 20.44 | 16.89 |
| Oxygen in the gas, %..... | 7.71 | — | 7.41 | 4.45 |
| Calculated value of a^* | 57 (?) | 244 | 255 | 403 |

BABCOCK & WILCOX TESTS.

| Test No. | 1 | 2 | 3 | 4 | 5 | 6 | 7 |
|------------------------------------|-------|-------|-------|-------|-------|-------|-------|
| Rate of driving, W/S | 5.18 | 5.57 | 8.42 | 8.75 | 10.07 | 9.58 | 13.67 |
| Evaporation, E_a | 12.19 | 12.70 | 11.47 | 11.50 | 11.43 | 11.12 | 10.52 |
| Efficiency, %..... | 74.8 | 77.9 | 70.4 | 70.6 | 70.1 | 68.2 | 64.5 |
| Lbs. dry gas per lb. C., f | 16.8 | 19.1 | 17.3 | 18.8 | 20.6 | 17.3 | 18.6 |
| Oxygen in the gas, %..... | 4.5 | 5.7 | 4.2 | 5.7 | 6.9 | 4.8 | 5.8 |
| Calculated value of a | 454 | 313 | 383 | 267 | 191 | 410 | 235 |

The relation of the efficiency to the rate of driving, in both sets

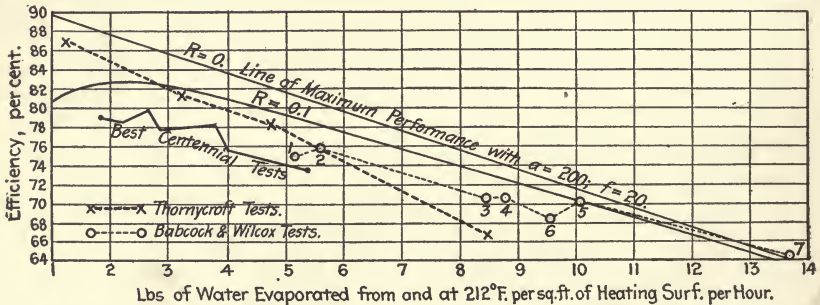

FIG. 121.—THORNYCROFT AND BABCOCK & WILCOX TESTS COMPARED.

of tests, is plotted in the diagram Fig. 121. There are also plotted, for comparison, a line representing the maximum theoretical performance of a boiler in which there is no loss by radiation, with f , or pounds of dry gas per pound of carbon = 20, $a = 200$, $t = 300$, and $K = 15,750$, no account being taken of the loss of heat due to super-

*The value of a obtained from the first test is so low as to indicate an error either in the record of the test itself or in the assumptions made in the calculation. If we assume no loss by radiation, making $R = 0$, the value of a becomes 294. At very low rates of driving a small difference in the assumed value of R makes a great difference in the computed value of a , but at high rates of driving it is of small importance.

heated steam in the chimney-gases; together with a line representing the same data but with a radiation factor of $R = 0.1$. The record of the seven best tests made at the Centennial Exhibition, taken from the diagram Fig. 49, p. 223, is also shown.

Comparing the results of the tests as plotted with the lines of theoretical maximum performance, it will be seen that the results lie remarkably close to the lines. The two tests that are farthest from the line, No. 1 of the Babcock & Wilcox tests and No. 4 of the Thornycroft tests, are those in which the quantity of gas per pound of carbon are the least, and the comparatively low results in these tests are therefore no doubt due to imperfect combustion.

These two sets of tests, taken together, form the best record of high performance at widely different rates of driving that has yet been published. The record is above that of the best records obtained in the Centennial tests with anthracite coal.

To account for these high results we have the analyses of the chimney-gases, which show that in the best tests the oxygen in the gas is over 5 per cent and the number of pounds of dry gas per pound of carbon from 17 to 21. The best results correspond to low values of the coefficient of performance, a . By plotting the computed

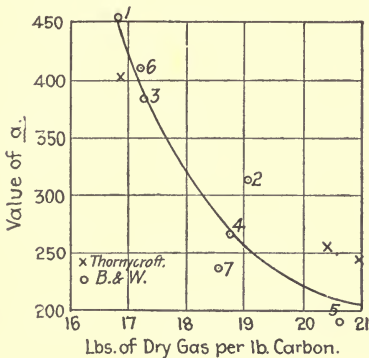

FIG. 122.—RELATION OF a TO LBS. OF GAS PER LB. C.

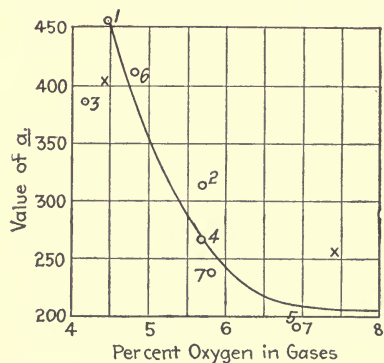

FIG. 123.—RELATION OF a TO OXYGEN IN THE GASES.

values of a with reference to the pounds of gas per pound of carbon, and to the per cent of oxygen in the gas, as in Figs. 122 and 123, we find that the minimum value of a seems to correspond to about 21 lbs. of gas per pound of carbon, and about 7 per cent oxygen in the gases. The rapid rise of the value of a with decrease of oxygen in the gases is to be expected, because the value calculated by the

formula (16) is based on the assumption of perfect combustion, and with oxygen less than 7 per cent there is almost always some carbonic oxide present, showing that the combustion is imperfect. When the pounds of dry gas per pound of carbon exceed 21 and the per cent of oxygen exceeds 8, the calculated value of a should be independent of these quantities.

Since high efficiency, according to formula (15), depends on both a and f being small, and since a is affected by f so as to increase rapidly when f is less than 20, it is evident that although a appears to have a minimum value when f is about or above 21, maximum efficiency will be obtained when a is at some value higher than its minimum value, and when f is somewhat less than 21. The Babcock & Wilcox test No. 7, with $a = 235$ and $f = 18.6$, gives a higher relative efficiency (as compared with the line of maximum theoretical performance) than test No. 5, with $a = 191$ and $f = 20.6$.

The record of the Thornycroft test No. 1, showing 86.8 per cent efficiency, probably contains some error. The test was only of five hours' duration, and only 1006 lbs. of coal was burned in the whole test. A slight error in the measurement of coal or water, and especially an error due to fluctuation of the water-level, would make an important error in the result at this very low rate of driving.

Tests with Anthracite at the Centennial Exhibition, 1876.—A brief summary of these tests has already been given on page 291, and the results are plotted on the diagram, Fig. 107, page 290. Some of the results are also plotted on the diagram, Fig. 49, page 223, for comparison with theoretical performance under certain assumed conditions. Of the fourteen boilers tested, illustrations of seven have already been given, as follows: Root, page 268; Firmenich, page 265; Babcock & Wilcox, page 266; Galloway, page 248; Wiegand and Kelly, page 260; Rogers & Black, page 262. The Root boiler used in the test differed from the one shown on page 268 in not having the series of horizontal longitudinal steam- and water-drums, a single transverse drum being used instead. The other seven boilers are illustrated and briefly described below.

The Lowe boiler, Fig. 124, is an ordinary cylindrical tubular boiler $4 \times 18\frac{1}{2}$ ft. with forty-six tubes 3 ins. \times 15 ft., with a chamber or connection in the front end of the boiler, the rear of which forms the front tube-sheet. The bridge-wall back of the grate is extended up to the shell. The heated gases pass through side openings through the water-space into the front chamber, thence through the tubes to the rear of the boiler, then through a return-flue along the lower half

of the shell to the rear of the bridge-wall, when they rise through two side flues, and circulating around the upper half of the shell and a superheating drum, escape to the uptake.

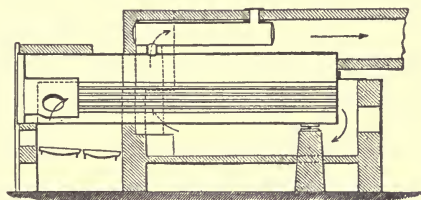

FIG. 124.—THE LOWE BOILER.

The Smith boiler, Fig. 125, is an ordinary return-tubular boiler, supplied with additional heating surface in the setting.

From the hollow cast-iron bridge-wall a number of pipes run horizontally under and back of the boiler and connect to short vertical tubes screwed into a larger horizontal pipe located back of the

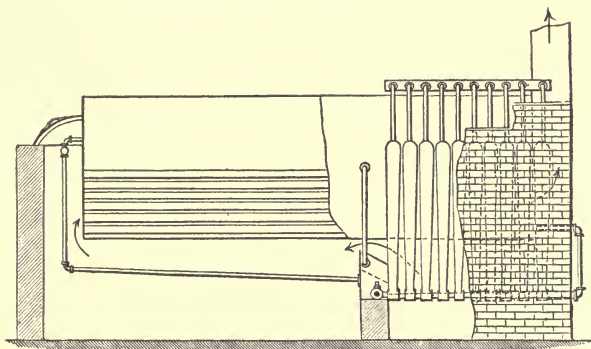

FIG. 125.—THE SMITH BOILER.

shell and connected thereto. In addition to the above, two cast-iron pipes run along either side of and below the grate and are connected with the water-space in the shell. In the latter are attached on either side a series of vertical conical castings, bulb-shaped at their tops, with

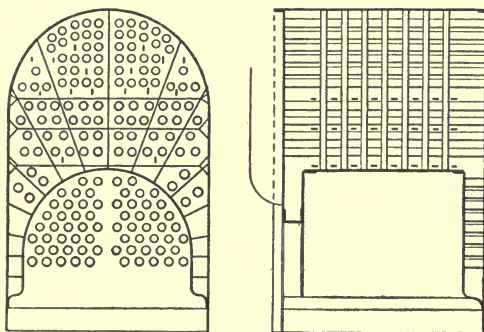

FIG. 126.—THE ANDREWS BOILER.

a small wrought-iron pipe in each as an outlet for steam, and the several small steam-pipes are connected together and to the steam-space of the main shell.

The Andrews boiler, Fig. 126, is of the double marine tubular type with internal furnace and external sheet-iron connections for directing the products of combustion from the lower set of tubes to the upper. The shell is rectangular with a semi-cylindrical top.

The Harrison boiler, Fig. 127, consists of sections of hollow cast-iron spheres, 8 ins. diameter, with curved necks, cast in groups of two and four and held together by bolts extending through the spheres and necks the entire length of the sections. The sections are set side by side at the angle shown.

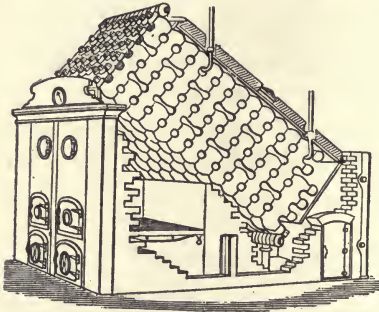

FIG. 127.—THE HARRISON BOILER.

The Anderson boiler, Fig. 128, is composed of sections, each containing nine wrought-iron tubes 3 ins. diameter and 10 ft. long, which are nearly horizontal and arranged in a vertical row. The four lower tubes are secured at their front ends to a cast-iron chamber and rise a little from front to rear. The front ends of the five upper tubes are similarly attached to an upper chamber, and slope a little from front to rear. The rear ends of all the tubes are united by a manifold. The lower front chambers are connected at their lower ends and the upper front chambers at their upper

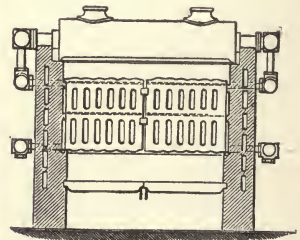
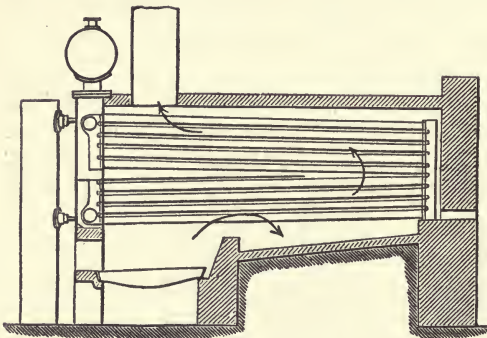

FIG. 128.—THE ANDERSON BOILER. FIG. 129.—THE EXETER BOILER.

ends. A horizontal partition is placed above the four lower tubes, so as to compel the gases to flow first along the four lower tubes and then along the five upper tubes.

The Exeter boiler, Fig. 129, consists of hollow, rectangular, cast-iron, slab-shaped sections set transversely, with twelve oblong openings in two horizontal flues through each section. Twenty-seven such sections are placed one in the rear of the other and connected through short side pipes to one steam- and one feed-pipe, thus forming a complete boiler. Two of these boilers are placed side by side over one grate. The gases from the grate pass to the rear of the boiler through the lower row of passages and return through the upper rows.

The Pierce boiler, Fig. 130, consists of a flat-ended cylinder directly above the fire-grate, revolving on trunnions. The heated gases envelop the cylinder and enter one end of an annular row of tubes in the shell, and after passing through them return through another row of tubes concentric with the first and thence escape to the chimney. Cups are secured around the tubes of the outer row, to

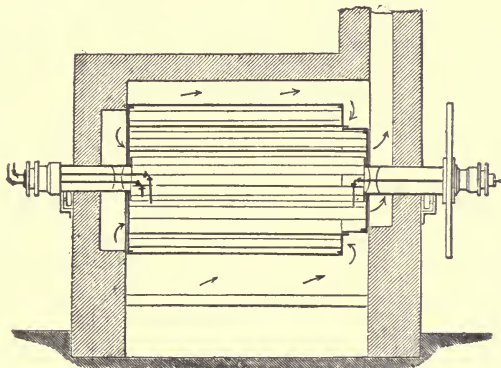

FIG. 130.—THE PIERCE BOILER.

catch the water whenever the tube is lifted above the water-line by the revolving of the shell, and thus prevent overheating of these tubes and of the shell. The feed-water is introduced through one trunnion and steam is taken out through the other.

Some of the conclusions which may be drawn from the results of the Centennial tests are the following:

1. The high results obtained by the first five boilers on the list, page 291, viz.: the Root, Firmenich, Lowe, Smith, Babcock & Wilcox, and Galloway boilers, constitute a standard of performance which has not been excelled since 1876 in any properly authenticated series of tests with anthracite coal.

2. These high figures being obtained with boilers of widely different types, it is evident that economy of fuel does not depend to any great extent on the type of boiler.

3. The low results obtained in the tests of all the other boilers are not explained by their design, or by anything in the record of their tests. Of the possible causes of low performance are excessive air-supply, especially at the higher rates of driving; short-circuiting of the gases; excessive loss by radiation. The lack of analyses of the chimney-gases prevents the drawing of any definite conclusions in regard to the air-supply.

CHAPTER XVI.*

PROPERTIES OF WATER AND OF STEAM—FACTORS OF EVAPORATION—CHIMNEYS.

WATER.

Weight of Water at Different Temperatures.—The weight of water at maximum density, 39.1°, is generally taken at the figure given by Rankine, 62.425 lbs. per cu. ft. Some authorities give as low as 62.379. The figure 62.5 commonly given is approximate. The highest authoritative figure is 62.425. At 62° F. the figures range from 62.291 to 62.360. The figure 62.355 is generally accepted as the most accurate.

At 32° F. figures given by different writers range from 62.379 to 62.418. Clark gives the latter figure and Hamilton Smith, Jr. (from Rosetti), gives 62.416.

Weight of Water at Temperatures above 212° F.—Porter (Richards' "Steam-engine Indicator," p. 52) says that nothing is known about the expansion of water above 212°. Applying formulæ derived from experiments made at temperatures below 212°, however, the weight and volume above 212° may be calculated, but in the absence of experimental data we are not certain that the formulæ hold good at higher temperatures.

Thurston, in his "Engine and Boiler Trials," gives a table from which we take the following (neglecting the third decimal place given by him):

| Temperature, deg. F. | Weight, lbs. per Cubic Foot. | Temperature, deg. F. | Weight, lbs. per Cubic Foot. | Temperature, deg. F. | Weight, lbs. per Cubic Foot. | Temperature, deg. F. | Weight, lbs. per Cubic Foot. | Temperature, deg. F. | Weight, lbs. per Cubic Foot. |
|----------------------|------------------------------|----------------------|------------------------------|----------------------|------------------------------|----------------------|------------------------------|----------------------|------------------------------|
| 212 | 59.71 | 280 | 57.90 | 350 | 55.52 | 420 | 52.86 | 490 | 50.03 |
| 220 | 59.64 | 290 | 57.59 | 360 | 55.16 | 430 | 52.47 | 500 | 49.61 |
| 230 | 59.37 | 300 | 57.26 | 370 | 54.79 | 440 | 52.07 | 510 | 49.20 |
| 240 | 59.10 | 310 | 56.93 | 380 | 54.41 | 450 | 51.66 | 520 | 48.78 |
| 250 | 58.81 | 320 | 56.58 | 390 | 54.03 | 460 | 51.26 | 530 | 48.36 |
| 260 | 58.52 | 330 | 56.24 | 400 | 53.64 | 470 | 50.85 | 540 | 47.94 |
| 270 | 58.21 | 340 | 55.88 | 410 | 53.26 | 480 | 50.44 | 550 | 47.52 |

Box on Heat gives the following:

| | | | | | | | | |
|--------------------------|-------|-------|-------|-------|-------|-------|-------|-------|
| Temperature F..... | 212° | 250° | 300° | 350° | 400° | 450° | 500° | 600° |
| Lbs. per cubic foot..... | 59.82 | 58.85 | 57.42 | 55.94 | 54.34 | 52.70 | 51.02 | 47.64 |

* This chapter is compiled from the author's "Mechanical Engineers' Pocket-book."

formula, with corrections for apparent errors, was published by the author in 1884, *Trans. A. S. M. E.*, vi. 90. (For heat-units above 212° see Steam Tables.)

STEAM.

The Temperature of Steam in contact with water depends upon the pressure under which it is generated. At the ordinary atmospheric pressure (14.7 lbs. per sq. in.) its temperature is 212° F. As the pressure is increased, as by the steam being generated in a closed vessel, its temperature, and that of the water in its presence, increases.

Saturated Steam is steam of the temperature due to its pressure—not superheated.

Superheated Steam is steam heated to a temperature above that due to its pressure.

Dry Steam is steam which contains no moisture. It may be either saturated or superheated.

Wet Steam is steam containing intermingled moisture, mist, or spray. It has the same temperature as dry saturated steam of the same pressure.

Water introduced into the presence of superheated steam will flash into vapor until the temperature of the steam is reduced to that due its pressure. Water in the presence of saturated steam has the same temperature as the steam. Should cold water be introduced, lowering the temperature of the whole mass, some of the steam will be condensed, reducing the pressure and temperature of the remainder, until an equilibrium is established.

Temperature and Pressure of Saturated Steam.—The relation between the temperature and the pressure of steam, according to Regnault's experiments, is expressed by the formula (Buchanan's, as

given by Clark) $t = \frac{2938.16}{6.1993544 - \log p} - 371.85$, in which p is the pressure in pounds per square inch and t the temperature of the steam in Fahrenheit degrees. It applies with accuracy between 120° F. and 446° F., corresponding to pressures of from 1.68 lbs. to 445 lbs. per sq. in. (For other formulæ see Wood's and Peabody's "Thermodynamics.")

Latent Heat of Steam.—The formula for latent heat of steam, as given by Rankine and others, is $L = 1091.7 - .695(t - 32^\circ)$.

Total Heat of Saturated Steam (above 32° F.).—According to Regnault's experiments, the formula for total heat of steam is $H = 1091.7 + .305(t - 32^\circ)$, in which t is temperature Fahr. and H the heat-units. (Rankine)

The total heat in steam (above 32°) includes three elements:

1st. The heat required to raise the temperature of the water to the temperature of the steam.

2d. The heat required to evaporate the water at that temperature, called internal latent heat.

3d. The latent heat of volume, or the external work done by the steam in making room for itself against the pressure of the superincumbent atmosphere. (or surrounding steam if inclosed in a vessel).

The sum of the last two elements is called the latent heat of steam. In Buel's tables (Weisbach, vol. ii, Dubois's translation) the two elements are given separately.

Density and Volume of Saturated Steam.—The density of steam is expressed by the weight of a given volume, say 1 cu. ft.; and the volume is expressed by the number of cubic feet in one lb. of steam.

Mr. Brownlee's expression for the density of saturated steam in terms of the pressure is $D = \frac{p^{0.941}}{330.36}$, or $\log D = 0.941p - 2.519$, in which D is the density, and p the pressure in pounds per square inch. In this expression, $p^{0.941}$ is the equivalent of p raised to the 16/17 power, as employed by Rankine.

The volume v being the reciprocal of the density,

$$v = \frac{330.36}{p^{0.941}}, \text{ or } \log v = 2.519 - 0.941 \log p.$$

Relative Volume of Steam.—The relative volume of saturated steam is expressed by the number of volumes of steam produced from one volume of water at 39° F. The relative volume is found by multiplying the volume in cu. ft. of one lb. of steam by the weight of a cu. ft. of water at 39° F., or 62.425 lbs.

Gaseous Steam.—When saturated steam is superheated, or surcharged with heat, it advances from the condition of saturation into that of gaseity. The gaseous state is only arrived at by considerably elevating the temperature, if the pressure remains the same. Steam thus sufficiently superheated is known as gaseous steam or steam-gas.

The Specific Heat of Gaseous Steam is 0.475, under constant pressure, as found by Regnault. It is identical with the coefficient of increase of total heat for each degree of temperature. [This is at atmospheric pressure and 212° F. He found it not true for any other pressures. Theory indicates that it would be greater at higher temperatures. (Prof. Wood.)]

Total Heat of Gaseous Steam.—Wood gives for the total heat (above 32°) of superheated steam $H = 1091.7 + 0.48(t - 32^\circ)$.

The Specific Density of Gaseous Steam is 0.622, that of air being 1. That is to say, the weight of a cubic foot of gaseous steam is about five-eighths of that of a cubic foot of air of the same pressure and temperature.

The density or weight of a cubic foot of gaseous steam is expressible by the formula

$$D' = \frac{2.7074p \times 0.622}{t + 461} = \frac{1.684p}{t + 461},$$

in which D' is the weight of a cubic foot of gaseous steam, p the total pressure in lbs. per square inch, and t the temperature Fahrenheit.

Identification of Dry Steam by Appearance of a Jet.—Prof. Denton (Trans. A. S. M. E., vol. x) found that jets of steam show unmistakable change of appearance to the eye when steam varies less than 1 per cent from the condition of saturation either in the direction of wetness or superheating.

If a jet of steam flow from a boiler into the atmosphere under circumstances such that very little loss of heat occurs through radiation, etc., and the jet be transparent close to the orifice, or be even a grayish-white color, the steam may be assumed to be so nearly dry that no portable condensing calorimeter will be capable of measuring the amount of water in the steam. If the jet be strongly white, the amount of water may be roughly judged up to about 2 per cent, but beyond this a calorimeter only can determine the exact amount of moisture.

Table of the Properties of Saturated Steam.—In the table of properties of saturated steam on the following pages the figures for temperature, total heat, and latent heat are taken, up to 210 lbs. absolute pressure, from the tables in Porter's "Steam-engine Indicator." The figures for weight per cubic foot and for cubic feet per pound have been taken from Dwelshauvers-Dery's table, Trans. A. S. M. E., vol. xi. The figures for relative volume are from Buel's table, in Dubois's translation of Weisbach, vol. ii. From 211 to 219 lbs. the figures for temperature, total heat, and latent heat are from Dwelshauvers's table; and from 220 to 1000 lbs. all the figures are from Buel's table.

WEIGHT OF 1 CUBIC FOOT OF STEAM IN DECIMALS OF A POUND. COMPARISON OF DIFFERENT AUTHORITIES.

| Absolute Pressure, lbs. per sq. in. | Weight of 1 Cubic Foot according to | | | | | Absolute Pressure, lbs. per sq. in. | Weight of 1 Cubic Foot according to | | | | |
|-------------------------------------|-------------------------------------|--------|--------|--------------|----------|-------------------------------------|-------------------------------------|--------|-------|--------------|----------|
| | Porter. | Clark. | Buel. | Dwelshauvers | Peabody. | | Porter. | Clark. | Buel. | Dwelshauvers | Peabody. |
| 1 | .0030 | .003 | .00303 | .00299 | .00299 | 120 | .27428 | .2738 | .2735 | .2724 | .2695 |
| 14.7 | .03797 | .0380 | .03793 | | .0376 | 140 | .31386 | .3162 | .3163 | .3147 | .3113 |
| 20 | .0511 | .0507 | .0507 | .0507 | .0502 | 160 | .35209 | .3590 | .3589 | .3567 | .3530 |
| 40 | .0994 | .0974 | .0972 | .0972 | .0964 | 180 | .38895 | .4009 | .4012 | .3983 | .3945 |
| 60 | .1457 | .1425 | .1424 | .1422 | .1409 | 200 | .42496 | .4431 | .4433 | .4400 | .4359 |
| 80 | .19015 | .1869 | .1866 | .1862 | .1843 | 220 | | .4842 | .4852 | | .4772 |
| 100 | .23302 | .2307 | .2303 | .2296 | .2271 | 240 | | .5248 | .5270 | | .5186 |

There are considerable differences between the figures of weight and volume of steam as given by different authorities. Porter's figures are based on the experiments of Fairbairn and Tate. The figures given by the other authorities are derived from theoretical formulæ which are believed to give more reliable results than the experiments. The figures for temperature, total heat, and latent heat as given by different authorities show a practical agreement, all being derived from Regnault's experiments. See Peabody's Tables of Saturated Steam; also Jacobus, Trans. A. S. M. E., vol. xii. 593.

PROPERTIES OF SATURATED STEAM.

| Vacuum Gauge, Inches of Mer- cury. | Absolute Pressure, lbs. per sq. inch. | Temperature, Fahrenheit. | Total Heat above 32° F. | | Latent Heat L. $H - h$ Heat-units. | Relative Volume. Volume of Water at 39° F. = 1. | Volume, Cu. ft. in 1 lb. of Steam. | Weight of 1 Cubic Foot of Steam, Pounds. |
|---|--|-----------------------------|---|---|--|---|---------------------------------------|--|
| | | | In the Water. <i>h</i> Heat-units. | In the Steam. <i>H</i> Heat-units. | | | | |
| 29.74 | .089 | 32 | 0 | 1091.7 | 1091.7 | 208080 | 3333.3 | .00030 |
| 29.67 | .122 | 40 | 8 | 1094.1 | 1086.1 | 154330 | 2472.2 | .00040 |
| 29.56 | .176 | 50 | 18 | 1097.2 | 1079.2 | 107630 | 1724.1 | .00058 |
| 29.40 | .254 | 60 | 28.01 | 1100.2 | 1072.2 | 76370 | 1223.4 | .00082 |
| 29.19 | .359 | 70 | 38.02 | 1103.3 | 1065.3 | 54660 | 875.61 | .00115 |
| 28.90 | .502 | 80 | 48.04 | 1106.3 | 1058.3 | 39690 | 635.80 | .00158 |
| 28.51 | .692 | 90 | 58.06 | 1109.4 | 1051.3 | 29290 | 469.20 | .00213 |
| 28.00 | .943 | 100 | 68.08 | 1112.4 | 1044.4 | 21830 | 349.70 | .00286 |
| 27.88 | 1 | 102.1 | 70.09 | 1113.1 | 1043.0 | 20623 | 334.23 | .00299 |
| 25.85 | 2 | 126.3 | 94.44 | 1120.5 | 1026.0 | 10730 | 173.23 | .00577 |
| 23.83 | 3 | 141.6 | 109.9 | 1125.1 | 1015.3 | 7325 | 117.98 | .00848 |
| 21.78 | 4 | 153.1 | 121.4 | 1128.6 | 1007.2 | 5588 | 89.80 | .01112 |
| 19.74 | 5 | 162.3 | 130.7 | 1131.4 | 1000.7 | 4530 | 72.50 | .01373 |
| 17.70 | 6 | 170.1 | 138.6 | 1133.8 | 995.2 | 3816 | 61.10 | .01631 |
| 15.67 | 7 | 176.9 | 145.4 | 1135.9 | 990.5 | 3302 | 53.00 | .01887 |
| 13.63 | 8 | 182.9 | 151.5 | 1137.7 | 986.2 | 2912 | 46.60 | .02140 |
| 11.60 | 9 | 188.3 | 156.9 | 1139.4 | 982.4 | 2607 | 41.82 | .02391 |
| 9.56 | 10 | 193.2 | 161.9 | 1140.9 | 979.0 | 2361 | 37.80 | .02641 |
| 7.52 | 11 | 197.8 | 166.5 | 1142.3 | 975.8 | 2159 | 34.61 | .02889 |
| 5.49 | 12 | 202.0 | 170.7 | 1143.5 | 972.8 | 1990 | 31.90 | .03136 |
| 3.45 | 13 | 205.9 | 174.7 | 1144.7 | 970.0 | 1846 | 29.58 | .03381 |
| 1.41 | 14 | 209.6 | 178.4 | 1145.9 | 967.4 | 1721 | 27.59 | .03625 |
| Gauge- pressure lbs. per sq. in. | 14.7 | 212 | 180.9 | 1146.6 | 965.7 | 1646 | 26.36 | .03794 |
| 0.304 | 15 | 213.0 | 181.9 | 1146.9 | 965.0 | 1614 | 25.87 | .03868 |
| 1.3 | 16 | 216.3 | 185.3 | 1147.9 | 962.7 | 1519 | 24.33 | .04110 |
| 2.3 | 17 | 219.4 | 188.4 | 1148.9 | 960.5 | 1434 | 22.98 | .04352 |
| 3.3 | 18 | 222.4 | 191.4 | 1149.8 | 958.3 | 1359 | 21.78 | .04592 |
| 4.3 | 19 | 225.2 | 194.3 | 1150.6 | 956.3 | 1292 | 20.70 | .04831 |
| 5.3 | 20 | 227.9 | 197.0 | 1151.5 | 954.4 | 1231 | 19.72 | .05070 |
| 6.3 | 21 | 230.5 | 199.7 | 1152.2 | 952.6 | 1176 | 18.84 | .05308 |
| 7.3 | 22 | 233.0 | 202.2 | 1153.0 | 950.8 | 1126 | 18.03 | .05545 |
| 8.3 | 23 | 235.4 | 204.7 | 1153.7 | 949.1 | 1080 | 17.30 | .05782 |
| 9.3 | 24 | 237.8 | 207.0 | 1154.5 | 947.4 | 1038 | 16.62 | .06018 |
| 10.3 | 25 | 240.0 | 209.3 | 1155.1 | 945.8 | 998.4 | 15.99 | .06253 |
| 11.3 | 26 | 242.2 | 211.5 | 1155.8 | 944.3 | 962.3 | 15.42 | .06487 |
| 12.3 | 27 | 244.3 | 213.7 | 1156.4 | 942.8 | 928.8 | 14.88 | .06721 |
| 13.3 | 28 | 246.3 | 215.7 | 1157.1 | 941.3 | 897.6 | 14.38 | .06955 |
| 14.3 | 29 | 248.3 | 217.8 | 1157.7 | 939.9 | 868.5 | 13.91 | .07188 |
| 15.3 | 30 | 250.2 | 219.7 | 1158.3 | 938.9 | 841.3 | 13.48 | .07420 |
| 16.3 | 31 | 252.1 | 221.6 | 1158.8 | 937.2 | 815.8 | 13.07 | .07652 |
| 17.3 | 32 | 254.0 | 223.5 | 1159.4 | 935.9 | 791.8 | 12.63 | .07884 |
| 18.3 | 33 | 255.7 | 225.3 | 1159.9 | 934.6 | 769.2 | 12.32 | .08115 |
| 19.3 | 34 | 257.5 | 227.1 | 1160.5 | 933.4 | 748.0 | 11.98 | .08346 |
| 20.3 | 35 | 259.2 | 228.8 | 1161.0 | 932.2 | 727.9 | 11.66 | .08576 |
| 21.3 | 36 | 260.8 | 230.5 | 1161.5 | 931.0 | 708.8 | 11.36 | .08806 |
| 22.3 | 37 | 262.5 | 232.1 | 1162.0 | 929.8 | 690.8 | 11.07 | .09035 |

PROPERTIES OF SATURATED STEAM.—Continued.

| Gauge-pressure, lbs. per sq. in. | Absolute Pressure, lbs. per sq. inch. | Temperature, Fahrenheit. | Total Heat above 3° F. | | Latent Heat L , $\frac{H-h}{H}$, Heat-units. | Relative Volume, Volume of Water at 39° F. = 1. | Volume, Cu. ft. in 1 lb. of Steam. | Weight of 1 Cubic Foot of Steam, Pounds. |
|-------------------------------------|--|-----------------------------|--|--|---|---|---------------------------------------|--|
| | | | In the Water. h Heat-units. | In the Steam. H Heat-units. | | | | |
| 23.3 | 38 | 264.0 | 233.8 | 1162.5 | 928.7 | 673.7 | 10.79 | .09264 |
| 24.3 | 39 | 265.6 | 235.4 | .9 | 927.6 | 657.5 | 10.53 | .09493 |
| 25.3 | 40 | 267.1 | 236.9 | 1163.4 | 926.5 | 642.0 | 10.28 | .09721 |
| 26.3 | 41 | 268.6 | 238.5 | .9 | 925.4 | 627.3 | 10.05 | .09949 |
| 27.3 | 42 | 270.1 | 240.0 | 1164.3 | 924.4 | 613.3 | 9.83 | .1018 |
| 28.3 | 43 | 271.5 | 241.4 | .7 | 923.3 | 599.9 | 9.61 | .1040 |
| 29.3 | 44 | 272.9 | 242.9 | 1165.2 | 922.3 | 587.0 | 9.41 | .1063 |
| 30.3 | 45 | 274.3 | 244.3 | .6 | 921.3 | 574.7 | 9.21 | .1086 |
| 31.3 | 46 | 275.7 | 245.7 | 1166.0 | 920.4 | 563.0 | 9.02 | .1108 |
| 32.3 | 47 | 277.0 | 247.0 | .4 | 919.4 | 551.7 | 8.84 | .1131 |
| 33.3 | 48 | 278.3 | 248.4 | .8 | 918.5 | 540.9 | 8.67 | .1153 |
| 34.3 | 49 | 279.6 | 249.7 | 1167.2 | 917.5 | 530.5 | 8.50 | .1176 |
| 35.3 | 50 | 280.9 | 251.0 | .6 | 916.6 | 520.5 | 8.34 | .1198 |
| 36.3 | 51 | 282.1 | 252.2 | 1168.0 | 915.7 | 510.9 | 8.19 | .1221 |
| 37.3 | 52 | 283.3 | 253.5 | .4 | 914.9 | 501.7 | 8.04 | .1243 |
| 38.3 | 53 | 284.5 | 254.7 | .7 | 914.0 | 492.8 | 7.90 | .1266 |
| 39.3 | 54 | 285.7 | 256.0 | 1169.1 | 913.1 | 484.2 | 7.76 | .1288 |
| 40.3 | 55 | 286.9 | 257.2 | .4 | 912.3 | 475.9 | 7.63 | .1311 |
| 41.3 | 56 | 288.1 | 258.3 | .8 | 911.5 | 467.9 | 7.50 | .1333 |
| 42.3 | 57 | 289.1 | 259.5 | 1170.1 | 910.6 | 460.2 | 7.38 | .1355 |
| 43.3 | 58 | 290.3 | 260.7 | .5 | 909.8 | 452.7 | 7.26 | .1377 |
| 44.3 | 59 | 291.4 | 261.8 | .8 | 909.0 | 445.5 | 7.14 | .1400 |
| 45.3 | 60 | 292.5 | 262.9 | 1171.2 | 908.2 | 438.5 | 7.03 | .1422 |
| 46.3 | 61 | 293.6 | 264.0 | .5 | 907.5 | 431.7 | 6.92 | .1444 |
| 47.3 | 62 | 294.7 | 265.1 | .8 | 906.7 | 425.2 | 6.82 | .1466 |
| 48.3 | 63 | 295.7 | 266.2 | 1172.1 | 905.9 | 418.8 | 6.72 | .1488 |
| 49.3 | 64 | 296.8 | 267.2 | .4 | 905.2 | 412.6 | 6.62 | .1511 |
| 50.3 | 65 | 297.8 | 268.3 | .8 | 904.5 | 406.6 | 6.53 | .1533 |
| 51.3 | 66 | 298.8 | 269.3 | 1173.1 | 903.7 | 400.8 | 6.43 | .1555 |
| 52.3 | 67 | 299.8 | 270.4 | .4 | 903.0 | 395.2 | 6.34 | .1577 |
| 53.3 | 68 | 300.8 | 271.4 | .7 | 902.3 | 389.8 | 6.25 | .1599 |
| 54.3 | 69 | 301.8 | 272.4 | 1174.0 | 901.6 | 384.5 | 6.17 | .1621 |
| 55.3 | 70 | 302.7 | 273.4 | .3 | 900.9 | 379.3 | 6.09 | .1643 |
| 56.3 | 71 | 303.7 | 274.4 | .6 | 900.2 | 374.3 | 6.01 | .1665 |
| 57.3 | 72 | 304.6 | 275.3 | .8 | 899.5 | 369.4 | 5.93 | .1687 |
| 58.3 | 73 | 305.6 | 276.3 | 1175.1 | 898.9 | 364.6 | 5.85 | .1709 |
| 59.3 | 74 | 306.5 | 277.2 | .4 | 898.2 | 360.0 | 5.78 | .1731 |
| 60.3 | 75 | 307.4 | 278.2 | .7 | 897.5 | 355.5 | 5.71 | .1753 |
| 61.3 | 76 | 308.3 | 279.1 | 1176.0 | 896.9 | 351.1 | 5.63 | .1775 |
| 62.3 | 77 | 309.2 | 280.0 | .2 | 896.2 | 346.8 | 5.57 | .1797 |
| 63.3 | 78 | 310.1 | 280.9 | .5 | 895.6 | 342.6 | 5.50 | .1819 |
| 64.3 | 79 | 310.9 | 281.8 | .8 | 895.0 | 338.5 | 5.43 | .1840 |
| 65.3 | 80 | 311.8 | 282.7 | 1177.0 | 894.3 | 334.5 | 5.37 | .1862 |
| 66.3 | 81 | 312.7 | 283.6 | .3 | 893.7 | 330.6 | 5.31 | .1884 |
| 67.3 | 82 | 313.5 | 284.5 | .6 | 893.1 | 326.8 | 5.25 | .1906 |
| 68.3 | 83 | 314.4 | 285.3 | .8 | 892.5 | 323.1 | 5.18 | .1928 |
| 69.3 | 84 | 315.2 | 286.2 | 1178.1 | 891.9 | 319.5 | 5.13 | .1950 |
| 70.3 | 85 | 316.0 | 287.0 | .3 | 891.3 | 315.9 | 5.07 | .1971 |

PROPERTIES OF SATURATED STEAM.—Continued.

| Gauge-pressure, lbs. per sq. in. | Absolute Press- ure, lbs. per Square Inch. | Temperature, Fahrenheit. | Total Heat above 32° F. | | Latent Heat L , $H - h$, Heat-units. | Relative Volume, Vol. of Water at 39° F. = 1. | Volume, Cubic Feet in 1 lb. of Steam. | Weight of 1 Cu. Foot of Steam, Pounds. |
|-------------------------------------|--|-----------------------------|--|--|---|---|---|--|
| | | | In the Water, h Heat-units. | In the Steam, H Heat-units. | | | | |
| 71.3 | 86 | 316.8 | 287.9 | 1178.6 | 890.7 | 312.5 | 5.02 | .1993 |
| 72.3 | 87 | 317.7 | 288.7 | .8 | 890.1 | 309.1 | 4.96 | .2015 |
| 73.3 | 88 | 318.5 | 289.5 | 1179.1 | 889.5 | 305.8 | 4.91 | .2036 |
| 74.3 | 89 | 319.3 | 290.4 | .3 | 888.9 | 302.5 | 4.86 | .2058 |
| 75.3 | 90 | 320.0 | 291.2 | .6 | 888.4 | 299.4 | 4.81 | .2080 |
| 76.3 | 91 | 320.8 | 292.0 | .8 | 887.8 | 296.3 | 4.76 | .2102 |
| 77.3 | 92 | 321.6 | 292.8 | 1180.0 | 887.2 | 293.2 | 4.71 | .2123 |
| 78.3 | 93 | 322.4 | 293.6 | .3 | 886.7 | 290.2 | 4.66 | .2145 |
| 79.3 | 94 | 323.1 | 294.4 | .5 | 886.1 | 287.3 | 4.62 | .2166 |
| 80.3 | 95 | 323.9 | 295.1 | .7 | 885.6 | 284.5 | 4.57 | .2188 |
| 81.3 | 96 | 324.6 | 295.9 | 1181.0 | 885.0 | 281.7 | 4.53 | .2210 |
| 82.3 | 97 | 325.4 | 296.7 | .2 | 884.5 | 279.0 | 4.48 | .2231 |
| 83.3 | 98 | 326.1 | 297.4 | .4 | 884.0 | 276.3 | 4.44 | .2253 |
| 84.3 | 99 | 326.8 | 298.2 | .6 | 883.4 | 273.7 | 4.40 | .2274 |
| 85.3 | 100 | 327.6 | 298.9 | .8 | 882.9 | 271.1 | 4.36 | .2296 |
| 86.3 | 101 | 328.3 | 299.7 | 1182.1 | 882.4 | 268.5 | 4.32 | .2317 |
| 87.3 | 102 | 329.0 | 300.4 | .3 | 881.9 | 266.0 | 4.28 | .2339 |
| 88.3 | 103 | 329.7 | 301.1 | .5 | 881.4 | 263.6 | 4.24 | .2360 |
| 89.3 | 104 | 330.4 | 301.9 | .7 | 880.8 | 261.2 | 4.20 | .2382 |
| 90.3 | 105 | 331.1 | 302.6 | .9 | 880.3 | 258.9 | 4.16 | .2403 |
| 91.3 | 106 | 331.8 | 303.3 | 1183.1 | 879.8 | 256.6 | 4.12 | .2425 |
| 92.3 | 107 | 332.5 | 304.0 | .4 | 879.3 | 254.3 | 4.09 | .2446 |
| 93.3 | 108 | 333.2 | 304.7 | .6 | 878.8 | 252.1 | 4.05 | .2467 |
| 94.3 | 109 | 333.9 | 305.4 | .8 | 878.3 | 249.9 | 4.02 | .2489 |
| 95.3 | 110 | 334.5 | 306.1 | 1184.0 | 877.9 | 247.8 | 3.98 | .2510 |
| 96.3 | 111 | 335.2 | 306.8 | .2 | 877.4 | 245.7 | 3.95 | .2531 |
| 97.3 | 112 | 335.9 | 307.5 | .4 | 876.9 | 243.6 | 3.92 | .2553 |
| 98.3 | 113 | 336.5 | 308.2 | .6 | 876.4 | 241.6 | 3.88 | .2574 |
| 99.3 | 114 | 337.2 | 308.8 | .8 | 875.9 | 239.6 | 3.85 | .2596 |
| 100.3 | 115 | 337.8 | 309.5 | 1185.0 | 875.5 | 237.6 | 3.82 | .2617 |
| 101.3 | 116 | 338.5 | 310.2 | .2 | 875.0 | 235.7 | 3.79 | .2638 |
| 102.3 | 117 | 339.1 | 310.8 | .4 | 874.5 | 233.8 | 3.76 | .2660 |
| 103.3 | 118 | 339.7 | 311.5 | .6 | 874.1 | 231.9 | 3.73 | .2681 |
| 104.3 | 119 | 340.4 | 312.1 | .8 | 873.6 | 230.1 | 3.70 | .2703 |
| 105.3 | 120 | 341.0 | 312.8 | .9 | 873.2 | 228.3 | 3.67 | .2724 |
| 106.3 | 121 | 341.6 | 313.4 | 1186.1 | 872.7 | 226.5 | 3.64 | .2745 |
| 107.3 | 122 | 342.2 | 314.1 | .3 | 872.3 | 224.7 | 3.62 | .2766 |
| 108.3 | 123 | 342.9 | 314.7 | .5 | 871.8 | 223.0 | 3.59 | .2788 |
| 109.3 | 124 | 343.5 | 315.3 | .7 | 871.4 | 221.3 | 3.56 | .2809 |
| 110.3 | 125 | 344.1 | 316.0 | .9 | 870.9 | 219.6 | 3.53 | .2830 |
| 111.3 | 126 | 344.7 | 316.6 | 1187.1 | 870.5 | 218.0 | 3.51 | .2851 |
| 112.3 | 127 | 345.3 | 317.2 | .3 | 870.0 | 216.4 | 3.48 | .2872 |
| 113.3 | 128 | 345.9 | 317.8 | .4 | 869.6 | 214.8 | 3.46 | .2894 |
| 114.3 | 129 | 346.5 | 318.4 | .6 | 869.2 | 213.2 | 3.43 | .2915 |
| 115.3 | 130 | 347.1 | 319.1 | .8 | 868.7 | 211.6 | 3.41 | .2936 |
| 116.3 | 131 | 347.6 | 319.7 | 1188.0 | 868.3 | 210.1 | 3.38 | .2957 |
| 117.3 | 132 | 348.2 | 320.3 | .2 | 867.9 | 208.6 | 3.36 | .2978 |
| 118.3 | 133 | 348.8 | 320.8 | .3 | 867.5 | 207.1 | 3.33 | .3000 |
| 119.3 | 134 | 349.4 | 321.5 | .5 | 867.0 | 205.7 | 3.31 | .3021 |

PROPERTIES OF SATURATED STEAM.—Continued.

| Gauge-pressure, lbs. per sq. in. | Absolute Pres- sure, lbs. per Square Inch. | Temperature, Fahrenheit. | Total Heat above 32° F. | | Latent Heat L , $= H - h$, Heat-units. | Relative Volume, Vol. of Water at 32° F. = 1. | Volume, Cubic Feet in 1 lb. of Steam. | Weight of 1 Cu. Foot Steam, Pounds. |
|-------------------------------------|--|-----------------------------|--|--|---|---|---|---|
| | | | In the Water, h Heat- units. | In the Steam, H Heat- units. | | | | |
| 120.3 | 135 | 350.0 | 322.1 | 1188.7 | 866.6 | 204.2 | 3.29 | .3042 |
| 121.3 | 136 | 350.5 | 322.6 | .9 | 866.2 | 202.8 | 3.27 | .3063 |
| 122.3 | 137 | 351.1 | 323.2 | 1189.0 | 865.8 | 201.4 | 3.24 | .3084 |
| 123.3 | 138 | 351.8 | 323.8 | .2 | 865.4 | 200.0 | 3.22 | .3105 |
| 124.3 | 139 | 352.2 | 324.4 | .4 | 865.0 | 198.7 | 3.20 | .3126 |
| 125.3 | 140 | 352.8 | 325.0 | .5 | 864.6 | 197.3 | 3.18 | .3147 |
| 126.3 | 141 | 353.3 | 325.5 | .7 | 864.2 | 196.0 | 3.16 | .3169 |
| 127.3 | 142 | 353.9 | 326.1 | .9 | 863.8 | 194.7 | 3.14 | .3190 |
| 128.3 | 143 | 354.4 | 326.7 | 1190.0 | 863.4 | 193.4 | 3.11 | .3211 |
| 129.3 | 144 | 355.0 | 327.2 | .2 | 863.0 | 192.2 | 3.09 | .3232 |
| 130.3 | 145 | 355.5 | 327.8 | .4 | 862.6 | 190.9 | 3.07 | .3253 |
| 131.3 | 146 | 356.0 | 328.4 | .5 | 862.2 | 189.7 | 3.05 | .3274 |
| 132.3 | 147 | 356.6 | 328.9 | .7 | 861.8 | 188.5 | 3.04 | .3295 |
| 133.3 | 148 | 357.1 | 329.5 | .9 | 861.4 | 187.3 | 3.02 | .3316 |
| 134.3 | 149 | 357.6 | 330.0 | 1191.0 | 861.0 | 186.1 | 3.00 | .3337 |
| 135.3 | 150 | 358.2 | 330.6 | .2 | 860.6 | 184.9 | 2.98 | .3358 |
| 136.3 | 151 | 358.7 | 331.1 | .3 | 860.2 | 183.7 | 2.96 | .3379 |
| 137.3 | 152 | 359.2 | 331.6 | .5 | 859.9 | 182.6 | 2.94 | .3400 |
| 138.3 | 153 | 359.7 | 332.2 | .7 | 859.5 | 181.5 | 2.92 | .3421 |
| 139.3 | 154 | 360.2 | 332.7 | .8 | 859.1 | 180.4 | 2.91 | .3442 |
| 140.3 | 155 | 360.7 | 333.2 | 1192.0 | 858.7 | 179.2 | 2.89 | .3463 |
| 141.3 | 156 | 361.3 | 333.8 | .1 | 858.4 | 178.1 | 2.87 | .3483 |
| 142.3 | 157 | 361.8 | 334.3 | .3 | 858.0 | 177.0 | 2.85 | .3504 |
| 143.3 | 158 | 362.3 | 334.8 | .4 | 857.6 | 176.0 | 2.84 | .3525 |
| 144.3 | 159 | 362.8 | 335.3 | .6 | 857.2 | 174.9 | 2.82 | .3546 |
| 145.3 | 160 | 363.3 | 335.9 | .7 | 856.9 | 173.9 | 2.80 | .3567 |
| 146.3 | 161 | 363.8 | 336.4 | .9 | 856.5 | 172.9 | 2.79 | .3588 |
| 147.3 | 162 | 364.3 | 336.9 | 1193.0 | 856.1 | 171.9 | 2.77 | .3609 |
| 148.3 | 163 | 364.8 | 337.4 | .2 | 855.8 | 171.0 | 2.76 | .3630 |
| 149.3 | 164 | 365.3 | 337.9 | .3 | 855.4 | 170.0 | 2.74 | .3650 |
| 150.3 | 165 | 365.7 | 338.4 | .5 | 855.1 | 169.0 | 2.72 | .3671 |
| 151.3 | 166 | 366.2 | 338.9 | .6 | 854.7 | 168.1 | 2.71 | .3692 |
| 152.3 | 167 | 366.7 | 339.4 | .8 | 854.4 | 167.1 | 2.69 | .3713 |
| 153.3 | 168 | 367.2 | 339.9 | .9 | 854.0 | 166.2 | 2.68 | .3734 |
| 154.3 | 169 | 367.7 | 340.4 | 1194.1 | 853.6 | 165.3 | 2.66 | .3754 |
| 155.3 | 170 | 368.2 | 340.9 | .2 | 853.3 | 164.3 | 2.65 | .3775 |
| 156.3 | 171 | 368.6 | 341.4 | .4 | 852.9 | 163.4 | 2.63 | .3796 |
| 157.3 | 172 | 369.1 | 341.9 | .5 | 852.6 | 162.5 | 2.62 | .3817 |
| 158.3 | 173 | 369.6 | 342.4 | .7 | 852.3 | 161.6 | 2.61 | .3838 |
| 159.3 | 174 | 370.0 | 342.9 | .8 | 851.9 | 160.7 | 2.59 | .3858 |
| 160.3 | 175 | 370.5 | 343.4 | .9 | 851.6 | 159.8 | 2.58 | .3879 |
| 161.3 | 176 | 371.0 | 343.9 | 1195.1 | 851.2 | 158.9 | 2.56 | .3900 |
| 162.3 | 177 | 371.4 | 344.3 | .2 | 850.9 | 158.1 | 2.55 | .3921 |
| 163.3 | 178 | 371.9 | 344.8 | .4 | 850.5 | 157.2 | 2.54 | .3942 |
| 164.3 | 179 | 372.4 | 345.3 | .5 | 850.2 | 156.4 | 2.52 | .3962 |
| 165.3 | 180 | 372.8 | 345.8 | .7 | 849.9 | 155.6 | 2.51 | .3983 |
| 166.3 | 181 | 373.3 | 346.3 | .8 | 849.5 | 154.8 | 2.50 | .4004 |
| 167.3 | 182 | 373.7 | 346.7 | .9 | 849.2 | 154.0 | 2.48 | .4025 |
| 168.3 | 183 | 374.2 | 347.2 | 1196.1 | 848.9 | 153.2 | 2.47 | .4046 |

PROPERTIES OF SATURATED STEAM.—Continued.

| Gauge-pressure, Pounds per Square Inch. | Absolute Pres- sure, lbs. per Square Inch. | Temperature, Fahrenheit. | Total Heat Above 32° F. | | Latent Heat L , $H - h$, Heat-units. | Relative Volume, Vol. of Water at 32° F. = 1. | Volume, Cubic Feet in 1 lb. of Steam. | Weight of 1 Cubic Foot Steam, lb. |
|---|--|-----------------------------|--|--|---|---|---|---|
| | | | In the Water, h Heat-units. | In the Steam, H Heat-units. | | | | |
| 169.3 | 184 | 374.6 | 347.7 | 1196.2 | 848.5 | 152.4 | 2.46 | .4066 |
| 170.3 | 185 | 375.1 | 348.1 | .3 | 848.2 | 151.6 | 2.45 | .4087 |
| 171.3 | 186 | 375.5 | 348.6 | .5 | 847.9 | 150.8 | 2.43 | .4108 |
| 172.3 | 187 | 375.9 | 349.1 | .6 | 847.6 | 150.0 | 2.42 | .4129 |
| 173.3 | 188 | 376.4 | 349.5 | .7 | 847.2 | 149.2 | 2.41 | .4150 |
| 174.3 | 189 | 376.9 | 350.0 | .9 | 846.9 | 148.5 | 2.40 | .4170 |
| 175.3 | 190 | 377.3 | 350.4 | 1197.0 | 846.6 | 147.8 | 2.39 | .4191 |
| 176.3 | 191 | 377.7 | 350.9 | .1 | 846.3 | 147.0 | 2.37 | .4212 |
| 177.3 | 192 | 378.2 | 351.3 | .3 | 845.9 | 146.3 | 2.36 | .4233 |
| 178.3 | 193 | 378.6 | 351.8 | .4 | 845.6 | 145.6 | 2.35 | .4254 |
| 179.2 | 194 | 379.0 | 352.2 | .5 | 845.3 | 144.9 | 2.34 | .4275 |
| 180.3 | 195 | 379.5 | 352.7 | .7 | 845.0 | 144.2 | 2.33 | .4296 |
| 181.3 | 196 | 380.0 | 353.1 | .8 | 844.7 | 143.5 | 2.32 | .4317 |
| 182.3 | 197 | 380.3 | 353.6 | .9 | 844.4 | 142.8 | 2.31 | .4337 |
| 183.3 | 198 | 380.7 | 354.0 | 1198.1 | 844.1 | 142.1 | 2.29 | .4358 |
| 184.3 | 199 | 381.2 | 354.4 | .2 | 843.7 | 141.4 | 2.28 | .4379 |
| 185.3 | 200 | 381.6 | 354.9 | .3 | 843.4 | 140.8 | 2.27 | .4400 |
| 186.3 | 201 | 382.0 | 355.3 | .4 | 843.1 | 140.1 | 2.26 | .4420 |
| 187.3 | 202 | 382.4 | 355.8 | .5 | 842.8 | 139.5 | 2.25 | .4441 |
| 188.3 | 203 | 382.8 | 356.2 | .7 | 842.5 | 138.8 | 2.24 | .4462 |
| 189.3 | 204 | 383.2 | 356.6 | .8 | 842.2 | 138.1 | 2.23 | .4482 |
| 190.3 | 205 | 383.7 | 357.1 | 1199.0 | 841.9 | 137.5 | 2.22 | .4503 |
| 191.3 | 206 | 384.1 | 357.5 | .1 | 841.6 | 136.9 | 2.21 | .4523 |
| 192.3 | 207 | 384.5 | 357.9 | .2 | 841.3 | 136.3 | 2.20 | .4544 |
| 193.3 | 208 | 384.9 | 358.3 | .3 | 841.0 | 135.7 | 2.19 | .4564 |
| 194.3 | 209 | 385.3 | 358.8 | .5 | 840.7 | 135.1 | 2.18 | .4585 |
| 195.3 | 210 | 385.7 | 359.2 | .6 | 840.4 | 134.5 | 2.17 | .4605 |
| 196.3 | 211 | 386.1 | 359.6 | .7 | 840.1 | 133.9 | 2.16 | .4626 |
| 197.3 | 212 | 386.5 | 360.0 | .8 | 839.8 | 133.3 | 2.15 | .4646 |
| 198.3 | 213 | 386.9 | 360.4 | .9 | 839.5 | 132.7 | 2.14 | .4667 |
| 199.3 | 214 | 387.3 | 360.9 | 1200.1 | 839.2 | 132.1 | 2.13 | .4687 |
| 200.3 | 215 | 387.7 | 361.3 | .2 | 838.9 | 131.5 | 2.12 | .4707 |
| 201.3 | 216 | 388.1 | 361.7 | .3 | 838.6 | 130.9 | 2.12 | .4728 |
| 202.3 | 217 | 388.5 | 362.1 | .4 | 838.3 | 130.3 | 2.11 | .4748 |
| 203.3 | 218 | 388.9 | 362.5 | .6 | 838.1 | 129.7 | 2.10 | .4768 |
| 204.3 | 219 | 389.3 | 362.9 | .7 | 837.8 | 129.2 | 2.09 | .4788 |
| 205.3 | 220 | 389.7 | 362.2 | 1200.8 | 838.6* | 128.7 | 2.06 | .4852 |
| 215.3 | 230 | 393.6 | 366.2 | 1202.0 | 835.8 | 123.3 | 1.98 | .5061 |
| 225.3 | 240 | 397.3 | 370.0 | 1203.1 | 833.1 | 118.5 | 1.90 | .5270 |
| 235.3 | 250 | 400.9 | 373.8 | 1204.2 | 830.5 | 114.0 | 1.83 | .5478 |
| 245.3 | 260 | 404.4 | 377.4 | 1205.3 | 827.9 | 109.8 | 1.76 | .5686 |
| 255.3 | 270 | 407.8 | 380.9 | 1206.3 | 825.4 | 105.9 | 1.70 | .5894 |
| 265.3 | 280 | 411.0 | 384.3 | 1207.3 | 823.0 | 102.3 | 1.64 | .6101 |
| 275.3 | 290 | 414.2 | 387.7 | 1208.3 | 820.6 | 99.0 | 1.585 | .6308 |
| 285.3 | 300 | 417.4 | 390.9 | 1209.2 | 818.3 | 95.8 | 1.535 | .6515 |
| 335.3 | 350 | 432.0 | 406.3 | 1213.7 | 807.5 | 82.7 | 1.325 | .7545 |

* The discrepancies at 205.3 lbs. gauge are due to the change from Dwelshauvers-Dery's to Buel's figures.

PROPERTIES OF SATURATED STEAM.—Continued.

| Gauge-pressure, Pounds per Square Inch. | Absolute pres- sure, lbs. per Square Inch. | Temperature, Fahrenheit, | Total Heat Above 32° F. | | Latent Heat L , $= H - h$, Heat-units. | Relative Volume, Vol. of Water at 32° F. = 1. | Volume, Cubic Feet in 1 lb of Steam. | Weight of 1 Cubic Foot Steam, lb. |
|---|--|-----------------------------|--|--|---|---|--|---|
| | | | In the Water, h Heat- units. | In the Steam, H Heat- units. | | | | |
| 385.3 | 400 | 444.9 | 419.8 | 1217.7 | 797.9 | 72.8 | 1.167 | .8572 |
| 435.3 | 450 | 456.6 | 432.2 | 1221.3 | 789.1 | 65.1 | 1.042 | .9595 |
| 485.3 | 500 | 467.4 | 443.5 | 1224.5 | 781.0 | 58.8 | .942 | 1.062 |
| 535.3 | 550 | 477.5 | 454.1 | 1227.6 | 773.5 | 53.6 | .859 | 1.164 |
| 585.3 | 600 | 486.9 | 464.2 | 1230.5 | 766.3 | 49.3 | .790 | 1.266 |
| 635.3 | 650 | 495.7 | 473.6 | 1233.2 | 759.6 | 45.6 | .731 | 1.368 |
| 685.3 | 700 | 504.1 | 482.4 | 1235.7 | 753.3 | 42.4 | .680 | 1.470 |
| 735.3 | 750 | 512.1 | 490.9 | 1238.0 | 747.2 | 39.6 | .636 | 1.572 |
| 785.3 | 800 | 519.6 | 498.9 | 1240.3 | 741.4 | 37.1 | .597 | 1.674 |
| 835.3 | 850 | 526.8 | 506.7 | 1242.5 | 735.8 | 34.9 | .563 | 1.776 |
| 885.3 | 900 | 533.7 | 514.0 | 1244.7 | 730.6 | 33.0 | .532 | 1.878 |
| 935.3 | 950 | 540.3 | 521.3 | 1246.7 | 725.4 | 31.4 | .505 | 1.980 |
| 985.3 | 1000 | 546.8 | 528.3 | 1248.7 | 720.3 | 30.0 | .480 | 2.082 |

FACTORS OF EVAPORATION.

The table on the following pages was originally published by the author in Trans. A. S. M. E. vol. vi., 1884. It gives the factors for every 3° of temperature of feed-water from 32° to 212° F., and for every two pounds pressure of steam within the limits of ordinary working steam-pressures.

The difference in the factor corresponding to a difference of 3° temperature of feed is always either .0031 or .0032. For interpolation to find a factor for a feed-water temperature between 32° and 212°, not given in the table, take the factor for the nearest temperature and add or subtract, as the case may be, .0010 if the difference is .0031, and .0011 if the difference is .0032. As in nearly all cases a factor of evaporation to three decimal places is accurate enough, any error which may be made in the fourth decimal place by interpolation is of no practical importance.

The tables used in calculating these factors of evaporation are those given in Charles T. Porter's Treatise on the Richards' Steam-engine Indicator. The formula is $\text{Factor} = \frac{H - h}{965.7}$, in which H is the total heat of steam at the observed pressure, and h the total heat of feed-water of the observed temperature.

| Gauge-pressures, Absolute press., | Lbs. | | | | | | | | | |
|--------------------------------------|-------------------------|------------|------------|------------|------------|------------|------------|------------|------------|------------|
| | 10 + 15 | 20 + 25 | 30 + 35 | 40 + 45 | 40 + 55 | 45 + 60 | 50 + 65 | 52 + 67 | 54 + 69 | 56 + 71 |
| Feed-water, Temp. | FACTORS OF EVAPORATION. | | | | | | | | | |
| 212° F. | 1.0008 | 1.0088 | 1.0149 | 1.0197 | 1.0237 | 1.0254 | 1.0271 | 1.0277 | 1.0283 | 1.0290 |
| 209 | 35 | 1.0120 | 80 | 1.0228 | 68 | 86 | 1.0302 | 1.0309 | 1.0215 | 1.0321 |
| 206 | 66 | 51 | 1.0212 | 60 | 99 | 1.0317 | 34 | 40 | 46 | 52 |
| 203 | 98 | 83 | 43 | 91 | 1.0331 | 49 | 65 | 72 | 78 | 84 |
| 200 | 1.0129 | 1.0214 | 75 | 1.0323 | 62 | 80 | 97 | 1.0403 | 1.0409 | 1.0415 |
| 197 | 60 | 46 | 1.0306 | 54 | 94 | 1.0412 | 1.0428 | 34 | 41 | 47 |
| 194 | 92 | 77 | 38 | 85 | 1.0425 | 43 | 60 | 66 | 72 | 78 |
| 191 | 1.0223 | 1.0308 | 69 | 1.0417 | 57 | 74 | 91 | 97 | 1.0503 | 1.0510 |
| 188 | 55 | 40 | 1.0400 | 48 | 88 | 1.0506 | 1.0522 | 1.0528 | 35 | 41 |
| 185 | 86 | 71 | 32 | 80 | 1.0519 | 37 | 54 | 60 | 66 | 72 |
| 182 | 1.0317 | 1.0403 | 63 | 1.0511 | 51 | 68 | 85 | 91 | 98 | 1.0604 |
| 179 | 49 | 34 | 95 | 42 | 82 | 1.0600 | 1.0616 | 1.0623 | 1.0629 | 35 |
| 176 | 80 | 65 | 1.0526 | 74 | 1.0613 | 31 | 48 | 54 | 60 | 66 |
| 173 | 1.0411 | 97 | 57 | 1.0605 | 45 | 63 | 79 | 85 | 92 | 98 |
| 170 | 43 | 1.0528 | 89 | 36 | 76 | 94 | 1.0710 | 1.0717 | 1.0723 | 1.0729 |
| 167 | 74 | 59 | 1.0620 | 68 | 1.0707 | 1.0725 | 42 | 48 | 54 | 60 |
| 164 | 1.0505 | 91 | 51 | 99 | 39 | 56 | 73 | 80 | 86 | 92 |
| 161 | 37 | 1.0622 | 82 | 1.0730 | 70 | 88 | 1.0804 | 1.0811 | 1.0817 | 1.0823 |
| 158 | 68 | 53 | 1.0714 | 62 | 1.0801 | 1.0819 | 36 | 42 | 48 | 54 |
| 155 | 99 | 84 | 45 | 93 | 33 | 50 | 67 | 73 | 80 | 86 |
| 152 | 1.0631 | 1.0716 | 76 | 1.0824 | 64 | 82 | 98 | 1.0905 | 1.0911 | 1.0917 |
| 149 | 62 | 47 | 1.0808 | 55 | 95 | 1.0913 | 1.0930 | 36 | 42 | 48 |
| 146 | 93 | 78 | 39 | 87 | 1.0926 | 44 | 61 | 67 | 73 | 79 |
| 143 | 1.0724 | 1.0810 | 70 | 1.0918 | 58 | 75 | 92 | 98 | 1.1005 | 1.1011 |
| 140 | 56 | 41 | 1.0901 | 49 | 89 | 1.1007 | 1.1023 | 1.1030 | 36 | 42 |
| 137 | 87 | 72 | 33 | 80 | 1.1020 | 38 | 55 | 61 | 67 | 73 |
| 134 | 1.0818 | 1.0903 | 64 | 1.1012 | 51 | 69 | 86 | 92 | 98 | 1.1104 |
| 131 | 49 | 34 | 95 | 43 | 83 | 1.1100 | 1.1117 | 1.1123 | 1.1130 | 36 |
| 128 | 81 | 66 | 1.1026 | 74 | 1.1114 | 32 | 48 | 55 | 61 | 67 |
| 125 | 1.0912 | 97 | 57 | 1.1105 | 45 | 63 | 79 | 86 | 92 | 98 |
| 122 | 43 | 1.1028 | 89 | 36 | 76 | 94 | 1.1211 | 1.1217 | 1.1223 | 1.1229 |
| 119 | 74 | 59 | 1.1120 | 68 | 1.1207 | 1.1225 | 42 | 48 | 54 | 60 |
| 116 | 1.1005 | 90 | 51 | 99 | 39 | 56 | 73 | 79 | 86 | 92 |
| 113 | 36 | 1.1122 | 82 | 1.1230 | 70 | 88 | 1.1304 | 1.1310 | 1.1317 | 1.1323 |
| 110 | 68 | 53 | 1.1213 | 61 | 1.1301 | 1.1319 | 35 | 42 | 48 | 54 |
| 107 | 99 | 84 | 45 | 92 | 32 | 50 | 66 | 73 | 79 | 85 |
| 104 | 1.1130 | 1.1215 | 76 | 1.1323 | 63 | 81 | 98 | 1.1404 | 1.1410 | 1.1416 |
| 101 | 61 | 46 | 1.1307 | 55 | 94 | 1.1412 | 1.1429 | 35 | 41 | 47 |
| 98 | 92 | 77 | 38 | 86 | 1.1426 | 43 | 60 | 66 | 73 | 79 |
| 95 | 1.1223 | 1.1309 | 69 | 1.1417 | 57 | 75 | 91 | 97 | 1.1504 | 1.1510 |
| 92 | 55 | 40 | 1.1400 | 48 | 88 | 1.1506 | 1.1522 | 1.1529 | 35 | 41 |
| 89 | 86 | 71 | 31 | 79 | 1.1519 | 37 | 53 | 60 | 66 | 72 |
| 86 | 1.1317 | 1.1402 | 63 | 1.1510 | 50 | 68 | 84 | 91 | 97 | 1.1603 |
| 83 | 48 | 33 | 94 | 41 | 81 | 99 | 1.1616 | 1.1622 | 1.1628 | 34 |
| 80 | 79 | 64 | 1.1525 | 73 | 1.1612 | 1.1630 | 47 | 53 | 59 | 65 |
| 77 | 1.1410 | 95 | 56 | 1.1604 | 44 | 61 | 78 | 84 | 90 | 96 |
| 74 | 41 | 1.1526 | 87 | 35 | 75 | 92 | 1.1709 | 1.1715 | 1.1722 | 1.1728 |
| 71 | 72 | 58 | 1.1618 | 66 | 1.1706 | 1.1723 | 40 | 46 | 53 | 59 |
| 68 | 1.1504 | 89 | 49 | 97 | 37 | 55 | 71 | 78 | 84 | 90 |
| 65 | 35 | 1.1620 | 80 | 1.1728 | 68 | 86 | 1.1802 | 1.1809 | 1.1815 | 1.1821 |
| 62 | 66 | 51 | 1.1711 | 59 | 99 | 1.1817 | 33 | 40 | 46 | 52 |
| 59 | 97 | 82 | 43 | 90 | 1.1830 | 48 | 64 | 71 | 77 | 83 |

| Gauge-press., lbs. 58+ | 60 + | 62 + | 64 + | 66 + | 68 + | 70 + | 72 + | 74 + | 76 + | |
|------------------------|-------------------------|--------|--------|--------|--------|--------|--------|--------|--------|--------|
| Absolute press ... 73 | 75 | 77 | 79 | 81 | 83 | 85 | 87 | 89 | 91 | |
| Feed-water Temp. | FACTORS OF EVAPORATION. | | | | | | | | | |
| 212° F. | 1.0295 | 1.0301 | 1.0307 | 1.0312 | 1.0318 | 1.0323 | 1.0329 | 1.0334 | 1.0339 | 1.0344 |
| 209 | 1.0327 | 33 | 38 | 44 | 49 | 55 | 60 | 65 | 70 | 75 |
| 206 | 58 | 64 | 70 | 75 | 81 | 86 | 91 | 97 | 1.0402 | 1.0407 |
| 203 | 90 | 96 | 1.0401 | 1.0407 | 1.0412 | 1.0418 | 1.0423 | 1.0428 | 33 | 38 |
| 200 | 1.0421 | 1.0427 | 33 | 38 | 44 | 49 | 54 | 59 | 65 | 69 |
| 197 | 53 | 58 | 64 | 70 | 75 | 80 | 86 | 91 | 96 | 1.0501 |
| 194 | 84 | 90 | 96 | 1.0501 | 1.0507 | 1.0512 | 1.0517 | 1.0522 | 1.0527 | 32 |
| 191 | 1.0515 | 1.0521 | 1.0527 | 33 | 38 | 43 | 49 | 54 | 59 | 64 |
| 188 | 47 | 53 | 58 | 64 | 69 | 75 | 80 | 85 | 90 | 95 |
| 185 | 78 | 84 | 90 | 95 | 1.0601 | 1.0606 | 1.0611 | 1.0616 | 1.0622 | 1.0626 |
| 182 | 1.0610 | 1.0615 | 1.0621 | 1.0627 | 32 | 37 | 43 | 48 | 53 | 58 |
| 179 | 41 | 47 | 52 | 58 | 63 | 69 | 74 | 79 | 84 | 89 |
| 176 | 72 | 78 | 84 | 89 | 95 | 1.0700 | 1.0705 | 1.0711 | 1.0716 | 1.0721 |
| 173 | 1.0704 | 1.0709 | 1.0715 | 1.0721 | 1.0726 | 32 | 37 | 42 | 47 | 52 |
| 170 | 35 | 41 | 46 | 52 | 57 | 63 | 68 | 73 | 78 | 83 |
| 167 | 66 | 72 | 78 | 83 | 89 | 94 | 99 | 1.0805 | 1.0810 | 1.0815 |
| 164 | 98 | 1.0803 | 1.0809 | 1.0815 | 1.0820 | 1.0825 | 1.0831 | 36 | 41 | 46 |
| 161 | 1.0829 | 35 | 40 | 46 | 51 | 57 | 62 | 67 | 72 | 77 |
| 158 | 60 | 66 | 72 | 77 | 83 | 88 | 93 | 98 | 1.0904 | 1.0908 |
| 155 | 92 | 97 | 1.0903 | 1.0909 | 1.0914 | 1.0919 | 1.0925 | 1.0930 | 35 | 40 |
| 152 | 1.0923 | 1.0929 | 34 | 40 | 45 | 51 | 56 | 61 | 66 | 71 |
| 149 | 54 | 60 | 66 | 71 | 77 | 82 | 87 | 92 | 97 | 1.1002 |
| 146 | 85 | 91 | 97 | 1.1002 | 1.1008 | 1.1013 | 1.1018 | 1.1024 | 1.1029 | 34 |
| 143 | 1.1017 | 1.1022 | 1.1028 | 34 | 39 | 44 | 50 | 55 | 60 | 65 |
| 140 | 48 | 54 | 59 | 65 | 70 | 76 | 81 | 86 | 91 | 96 |
| 137 | 79 | 85 | 91 | 96 | 1.1102 | 1.1107 | 1.1112 | 1.1117 | 1.1122 | 1.1127 |
| 134 | 1.1110 | 1.1116 | 1.1122 | 1.1127 | 33 | 38 | 43 | 49 | 54 | 59 |
| 131 | 42 | 47 | 53 | 59 | 64 | 69 | 75 | 80 | 85 | 90 |
| 128 | 73 | 79 | 84 | 90 | 95 | 1.1201 | 1.1206 | 1.1211 | 1.1216 | 1.1221 |
| 125 | 1.1204 | 1.1210 | 1.1215 | 1.1221 | 1.1226 | 32 | 37 | 42 | 47 | 52 |
| 122 | 35 | 41 | 47 | 52 | 58 | 63 | 68 | 73 | 78 | 83 |
| 119 | 66 | 72 | 78 | 83 | 89 | 94 | 99 | 1.1305 | 1.1310 | 1.1315 |
| 116 | 98 | 1.1303 | 1.1309 | 1.1315 | 1.1320 | 1.1325 | 1.1331 | 36 | 41 | 46 |
| 113 | 1.1329 | 34 | 40 | 46 | 51 | 57 | 62 | 67 | 72 | 77 |
| 110 | 60 | 66 | 71 | 77 | 82 | 88 | 93 | 98 | 1.1403 | 1.1408 |
| 107 | 91 | 97 | 1.1403 | 1.1408 | 1.1414 | 1.1419 | 1.1424 | 1.1429 | 34 | 39 |
| 104 | 1.1422 | 1.1428 | 34 | 39 | 45 | 50 | 55 | 60 | 65 | 70 |
| 101 | 53 | 59 | 65 | 70 | 76 | 81 | 86 | 92 | 97 | 1.1502 |
| 98 | 85 | 90 | 90 | 1.1502 | 1.1507 | 1.1512 | 1.1518 | 1.1523 | 1.1528 | 33 |
| 95 | 1.1516 | 1.1521 | 1.1527 | 33 | 38 | 43 | 49 | 54 | 59 | 64 |
| 92 | 47 | 53 | 58 | 64 | 69 | 75 | 80 | 85 | 90 | 95 |
| 89 | 78 | 84 | 89 | 95 | 1.1600 | 1.1606 | 1.1611 | 1.1616 | 1.1621 | 1.1626 |
| 86 | 1.1609 | 1.1615 | 1.1621 | 1.1626 | 32 | 37 | 42 | 47 | 52 | 57 |
| 83 | 40 | 46 | 52 | 57 | 63 | 68 | 73 | 78 | 83 | 88 |
| 80 | 71 | 77 | 83 | 88 | 94 | 99 | 1.1704 | 1.1710 | 1.1715 | 1.1720 |
| 77 | 1.1702 | 1.1708 | 1.1714 | 1.1719 | 1.1725 | 1.1730 | 35 | 41 | 46 | 51 |
| 74 | 34 | 39 | 45 | 51 | 56 | 61 | 67 | 72 | 77 | 82 |
| 71 | 65 | 70 | 76 | 82 | 87 | 92 | 98 | 1.1803 | 1.1808 | 1.1813 |
| 68 | 96 | 1.1802 | 1.1807 | 1.1813 | 1.1818 | 1.1824 | 1.1829 | 34 | 39 | 44 |
| 65 | 1.1827 | 33 | 38 | 44 | 49 | 55 | 60 | 65 | 70 | 75 |
| 62 | 58 | 64 | 69 | 75 | 80 | 86 | 91 | 96 | 1.1901 | 1.1906 |
| 59 | 89 | 95 | 1.1901 | 1.1906 | 1.1912 | 1.1917 | 1.1923 | 1.1927 | 32 | 37 |

| Gauge press., lbs., 78 + Absolute Pressures.93 | 80 + 95 | 82 + 97 | 84 + 99 | 86 + 101 | 88 + 103 | 90 + 105 | 92 + 107 | 94 + 109 | 96 + 111 | 98 + 113 | |
|---|------------|------------|------------|-------------|-------------|-------------|-------------|-------------|-------------|-------------|--------|
| FACTORS OF EVAPORATION. | | | | | | | | | | | |
| 212 | 1.0349 | 1.0353 | 1.0358 | 1.0363 | 1.0367 | 1.0372 | 1.0376 | 1.0381 | 1.0385 | 1.0389 | 1.0393 |
| 209 | 80 | 81 | 90 | 94 | 99 | 1.0403 | 1.0408 | 1.0412 | 1.0416 | 1.0421 | 1.0425 |
| 206 | 1.0411 | 1.0416 | 1.0421 | 1.0426 | 1.0430 | 35 | 39 | 43 | 48 | 52 | 56 |
| 203 | 43 | 48 | 52 | 57 | 62 | 66 | 71 | 75 | 79 | 83 | 88 |
| 200 | 74 | 79 | 84 | 89 | 93 | 98 | 1.0502 | 1.0506 | 1.0511 | 1.0515 | 1.0519 |
| 197 | 1.0506 | 1.0511 | 1.0515 | 1.0520 | 1.0525 | 1.0529 | 33 | 38 | 42 | 46 | 50 |
| 194 | 37 | 42 | 47 | 51 | 56 | 60 | 65 | 69 | 73 | 78 | 82 |
| 191 | 69 | 73 | 78 | 83 | 87 | 92 | 96 | 1.0601 | 1.0605 | 1.0609 | 1.0613 |
| 188 | 1.0600 | 1.0605 | 1.0610 | 1.0614 | 1.0619 | 1.0623 | 1.0628 | 32 | 36 | 40 | 45 |
| 185 | 31 | 36 | 41 | 46 | 50 | 55 | 59 | 63 | 68 | 72 | 76 |
| 182 | 63 | 68 | 72 | 77 | 81 | 86 | 90 | 95 | 99 | 1.0703 | 1.0707 |
| 179 | 94 | 99 | 1.0705 | 1.0708 | 1.0713 | 1.0717 | 1.0722 | 1.0726 | 1.0730 | 35 | 39 |
| 176 | 1.0725 | 1.0730 | 35 | 40 | 44 | 49 | 53 | 57 | 62 | 66 | 70 |
| 173 | 57 | 62 | 66 | 71 | 75 | 80 | 84 | 89 | 93 | 97 | 1.0801 |
| 170 | 88 | 93 | 98 | 1.0802 | 1.0307 | 1.0811 | 1.0816 | 1.0820 | 1.0824 | 1.0829 | 33 |
| 167 | 1.0819 | 1.0824 | 1.0829 | 34 | 38 | 43 | 47 | 51 | 56 | 60 | 64 |
| 164 | 51 | 56 | 60 | 65 | 69 | 74 | 78 | 83 | 87 | 91 | 95 |
| 161 | 82 | 87 | 92 | 96 | 1.0901 | 1.0905 | 1.0910 | 1.0914 | 1.0918 | 1.0923 | 1.0927 |
| 158 | 1.0913 | 1.0918 | 1.0923 | 1.0927 | 32 | 37 | 41 | 45 | 50 | 54 | 58 |
| 155 | 45 | 49 | 54 | 59 | 63 | 68 | 72 | 77 | 81 | 85 | 89 |
| 152 | 76 | 81 | 85 | 90 | 95 | 99 | 1.1004 | 1.1008 | 1.1012 | 1.1016 | 1.1021 |
| 149 | 1.1007 | 1.1012 | 1.1017 | 1.1021 | 1.1026 | 1.1030 | 35 | 39 | 43 | 48 | 52 |
| 146 | 38 | 43 | 48 | 53 | 57 | 62 | 66 | 70 | 75 | 79 | 83 |
| 143 | 70 | 74 | 79 | 84 | 88 | 93 | 97 | 1.1102 | 1.1106 | 1.1110 | 1.1114 |
| 140 | 1.1101 | 1.1106 | 1.1110 | 1.1115 | 1.1120 | 1.1124 | 1.1129 | 33 | 37 | 41 | 46 |
| 137 | 32 | 37 | 42 | 46 | 51 | 55 | 60 | 64 | 68 | 73 | 77 |
| 134 | 63 | 68 | 73 | 78 | 82 | 87 | 91 | 95 | 1.1200 | 1.1204 | 1.1208 |
| 131 | 95 | 99 | 1.1204 | 1.1209 | 1.1213 | 1.1218 | 1.1222 | 1.1227 | 31 | 35 | 39 |
| 128 | 1.1226 | 1.1231 | 35 | 40 | 45 | 49 | 53 | 58 | 62 | 66 | 71 |
| 125 | 57 | 62 | 67 | 71 | 76 | 80 | 85 | 89 | 93 | 98 | 1.1302 |
| 122 | 88 | 93 | 98 | 1.1302 | 1.1307 | 1.1311 | 1.1316 | 1.1320 | 1.1325 | 1.1329 | 33 |
| 119 | 1.1320 | 1.1324 | 1.1329 | 34 | 38 | 43 | 47 | 51 | 56 | 60 | 64 |
| 116 | 51 | 55 | 60 | 65 | 69 | 74 | 78 | 83 | 87 | 91 | 95 |
| 113 | 82 | 87 | 91 | 96 | 1.1401 | 1.1405 | 1.1409 | 1.1414 | 1.1418 | 1.1422 | 1.1426 |
| 110 | 1.1413 | 1.1418 | 1.1422 | 1.1427 | 32 | 36 | 41 | 45 | 49 | 53 | 58 |
| 107 | 44 | 49 | 54 | 58 | 63 | 67 | 72 | 76 | 80 | 85 | 89 |
| 104 | 75 | 80 | 85 | 89 | 94 | 99 | 1.1503 | 1.1507 | 1.1512 | 1.1516 | 1.1520 |
| 101 | 1.1506 | 1.1511 | 1.1516 | 1.1521 | 1.1525 | 1.1530 | 34 | 38 | 43 | 47 | 51 |
| 98 | 38 | 42 | 47 | 52 | 56 | 61 | 65 | 70 | 74 | 78 | 82 |
| 95 | 69 | 74 | 78 | 83 | 87 | 92 | 96 | 1.1601 | 1.1605 | 1.1609 | 1.1613 |
| 92 | 1.1600 | 1.1605 | 1.1609 | 1.1614 | 1.1619 | 1.1623 | 1.1628 | 32 | 36 | 40 | 45 |
| 89 | 31 | 36 | 41 | 45 | 50 | 54 | 59 | 63 | 67 | 72 | 76 |
| 86 | 62 | 67 | 72 | 76 | 81 | 85 | 90 | 94 | 98 | 1.1703 | 1.1707 |
| 83 | 93 | 98 | 1.1703 | 1.1707 | 1.1712 | 1.1717 | 1.1721 | 1.1725 | 1.1730 | 34 | 38 |
| 80 | 1.1724 | 1.1729 | 34 | 39 | 43 | 48 | 52 | 56 | 61 | 65 | 69 |
| 77 | 56 | 60 | 65 | 70 | 74 | 79 | 83 | 88 | 92 | 96 | 1.1800 |
| 74 | 8 | 91 | 9 | 1.1801 | 1.1805 | 1.1810 | 1.1814 | 1.1819 | 1.1823 | 1.1827 | 31 |
| 71 | 1.1818 | 1.1823 | 1.1827 | 32 | 36 | 41 | 45 | 50 | 54 | 58 | 62 |
| 68 | 49 | 54 | 58 | 63 | 68 | 72 | 77 | 81 | 85 | 89 | 94 |
| 65 | 80 | 85 | 89 | 94 | 99 | 1.1903 | 1.1908 | 1.1912 | 1.1916 | 1.1920 | 1.1925 |
| 62 | 1.1911 | 1.1916 | 1.1921 | 1.1925 | 1.1930 | 34 | 39 | 43 | 47 | 52 | 56 |
| 59 | 42 | 47 | 52 | 56 | 61 | 65 | 70 | 74 | 78 | 83 | 87 |

| Gauge-press lbs...100 + Absolute Press...115 | 105 + | 110 + | 115 + | 120 + | 125 + | 130 + | 135 + | 140 + | 145 + | 150 + | |
|---|--------|--------|--------|--------|--------|--------|--------|--------|--------|--------|--------|
| Feed- water Temp. | 120 | 125 | 130 | 135 | 140 | 145 | 150 | 155 | 160 | 165 | |
| FACTORS OF EVAPORATION. | | | | | | | | | | | |
| 212° | 1.0397 | 1.0407 | 1.0417 | 1.0427 | 1.0436 | 1.0445 | 1.0453 | 1.0462 | 1.0470 | 1.0478 | 1.0486 |
| 209 | 1.0429 | 39 | 49 | 58 | 67 | 76 | 85 | 93 | 1.0501 | 1.0509 | 1.0517 |
| 206 | 60 | 70 | 80 | 89 | 99 | 1.0508 | 1.0516 | 1.0525 | 33 | 41 | 48 |
| 203 | 92 | 1.0502 | 1.0511 | 1.0521 | 1.0530 | 39 | 48 | 56 | 64 | 72 | 80 |
| 200 | 1.0523 | 33 | 43 | 52 | 62 | 70 | 79 | 87 | 96 | 1.0604 | 1.0611 |
| 197 | 55 | 65 | 74 | 84 | 93 | 1.0602 | 1.0610 | 1.0619 | 1.0627 | 35 | 43 |
| 194 | 86 | 96 | 1.0606 | 1.0615 | 1.0624 | 33 | 42 | 50 | 58 | 66 | 74 |
| 191 | 1.0617 | 1.0627 | 37 | 47 | 56 | 65 | 73 | 82 | 90 | 98 | 1.0706 |
| 188 | 49 | 59 | 69 | 78 | 87 | 96 | 1.0705 | 1.0713 | 1.0721 | 1.0729 | 37 |
| 185 | 80 | 90 | 1.0700 | 1.0709 | 1.0719 | 1.0727 | 36 | 44 | 53 | 61 | 68 |
| 182 | 1.0712 | 1.0722 | 31 | 41 | 50 | 59 | 67 | 76 | 84 | 92 | 1.0800 |
| 179 | 43 | 53 | 63 | 72 | 81 | 90 | 99 | 1.0807 | 1.0815 | 1.0823 | 31 |
| 176 | 74 | 84 | 94 | 1.0803 | 1.0813 | 1.0821 | 1.0830 | 39 | 47 | 55 | 62 |
| 173 | 1.0806 | 1.0816 | 1.0825 | 35 | 44 | 53 | 61 | 70 | 78 | 86 | 94 |
| 170 | 37 | 47 | 57 | 66 | 75 | 84 | 93 | 1.0901 | 1.0909 | 1.0917 | 1.0925 |
| 167 | 68 | 78 | 88 | 97 | 1.0907 | 1.0915 | 1.0924 | 32 | 41 | 49 | 56 |
| 164 | 1.0900 | 1.0910 | 1.0919 | 1.0929 | 38 | 47 | 55 | 64 | 72 | 80 | 88 |
| 161 | 31 | 41 | 51 | 60 | 69 | 78 | 87 | 95 | 1.1003 | 1.1011 | 1.1019 |
| 158 | 62 | 72 | 82 | 91 | 1.1000 | 1.1009 | 1.1018 | 1.1026 | 35 | 43 | 50 |
| 155 | 93 | 1.1003 | 1.1013 | 1.1023 | 32 | 41 | 49 | 58 | 66 | 74 | 82 |
| 152 | 1.1025 | 35 | 44 | 54 | 63 | 72 | 81 | 89 | 97 | 1.1105 | 1.1113 |
| 149 | 56 | 66 | 76 | 85 | 94 | 1.1103 | 1.1112 | 1.1120 | 1.1128 | 36 | 44 |
| 146 | 87 | 97 | 1.1107 | 1.1116 | 1.1126 | 34 | 43 | 51 | 60 | 68 | 75 |
| 143 | 1.1118 | 1.1129 | 38 | 48 | 57 | 66 | 74 | 83 | 91 | 99 | 1.1207 |
| 140 | 50 | 60 | 70 | 79 | 88 | 97 | 1.1206 | 1.1214 | 1.1222 | 1.1230 | 38 |
| 137 | 81 | 91 | 1.1201 | 1.1210 | 1.1219 | 1.1228 | 37 | 45 | 53 | 61 | 69 |
| 134 | 1.1212 | 1.1222 | 32 | 41 | 51 | 59 | 68 | 76 | 85 | 93 | 1.1300 |
| 131 | 43 | 53 | 63 | 73 | 82 | 91 | 99 | 1.1308 | 1.1316 | 1.1324 | 32 |
| 128 | 75 | 85 | 94 | 1.1304 | 1.1313 | 1.1322 | 1.1331 | 39 | 47 | 55 | 63 |
| 125 | 1.1306 | 1.1316 | 1.1326 | 35 | 44 | 53 | 62 | 70 | 78 | 86 | 94 |
| 122 | 37 | 47 | 57 | 66 | 75 | 84 | 93 | 1.1401 | 1.1409 | 1.1417 | 1.1425 |
| 119 | 68 | 78 | 88 | 97 | 1.1407 | 1.1415 | 1.1424 | 32 | 41 | 49 | 56 |
| 116 | 99 | 1.1409 | 1.1419 | 1.1429 | 38 | 47 | 55 | 64 | 72 | 80 | 88 |
| 113 | 1.1431 | 41 | 50 | 60 | 69 | 78 | 86 | 95 | 1.1503 | 1.1511 | 1.1519 |
| 110 | 62 | 72 | 82 | 91 | 1.1500 | 1.1509 | 1.1518 | 1.1526 | 34 | 42 | 50 |
| 107 | 93 | 1.1503 | 1.1513 | 1.1522 | 31 | 40 | 49 | 57 | 65 | 73 | 81 |
| 104 | 1.1524 | 34 | 44 | 53 | 62 | 71 | 80 | 88 | 97 | 1.1605 | 1.1612 |
| 101 | 55 | 65 | 75 | 84 | 94 | 1.1602 | 1.1611 | 1.1620 | 1.1628 | 36 | 43 |
| 98 | 86 | 96 | 1.1606 | 1.1616 | 1.1625 | 34 | 42 | 51 | 59 | 67 | 75 |
| 95 | 1.1618 | 1.1628 | 37 | 47 | 56 | 65 | 73 | 82 | 90 | 98 | 1.1706 |
| 92 | 49 | 59 | 68 | 78 | 87 | 96 | 1.1705 | 1.1713 | 1.1721 | 1.1729 | 37 |
| 89 | 80 | 90 | 1.1700 | 1.1709 | 1.1718 | 1.1727 | 36 | 44 | 52 | 60 | 68 |
| 86 | 1.1711 | 1.1721 | 31 | 40 | 49 | 58 | 67 | 75 | 83 | 91 | 99 |
| 83 | 42 | 52 | 62 | 71 | 80 | 89 | 98 | 1.1806 | 1.1815 | 1.1823 | 1.1830 |
| 80 | 73 | 83 | 93 | 1.1802 | 1.1812 | 1.1820 | 1.1829 | 37 | 46 | 54 | 61 |
| 77 | 1.1804 | 1.1814 | 1.1824 | 34 | 43 | 52 | 60 | 69 | 77 | 85 | 93 |
| 74 | 35 | 45 | 55 | 65 | 74 | 83 | 91 | 1.1900 | 1.1908 | 1.1916 | 1.1924 |
| 71 | 67 | 77 | 86 | 96 | 1.1905 | 1.1914 | 1.1922 | 31 | 39 | 47 | 55 |
| 68 | 98 | 1.1908 | 1.1917 | 1.1927 | 36 | 45 | 54 | 62 | 70 | 78 | 86 |
| 65 | 1.1929 | 39 | 49 | 58 | 67 | 76 | 85 | 93 | 1.2001 | 1.2009 | 1.2017 |
| 62 | 60 | 70 | 80 | 89 | 98 | 1.2007 | 1.2016 | 1.2024 | 32 | 40 | 48 |
| 59 | 91 | 1.2001 | 1.2011 | 1.2020 | 1.2029 | 38 | 47 | 55 | 63 | 71 | 79 |

| Gauge pressures, 0+ Absolute press... 15 | Lbs. | | | | | | | | | |
|---|-------------------------|------------|------------|------------|------------|------------|------------|------------|------------|--------|
| | 10 + 25 | 20 + 35 | 30 + 45 | 40 + 55 | 45 + 60 | 50 + 65 | 52 + 67 | 54 + 69 | 56 + 71 | |
| Feed-water Temp. | FACTORS OF EVAPORATION. | | | | | | | | | |
| 56° F. | 1.1628 | 1.1713 | 1.1774 | 1.1821 | 1.1861 | 1.1879 | 1.1896 | 1.1902 | 1.1908 | 1.1914 |
| 53 | 59 | 44 | 1.1805 | 52 | 92 | 1.1910 | 1.1927 | 33 | 59 | 45 |
| 50 | 90 | 75 | 36 | 84 | 1.1923 | 41 | 58 | 64 | 70 | 76 |
| 47 | 1.1721 | 1.1806 | 67 | 1.1915 | 54 | 72 | 89 | 95 | 1.2001 | 1.2007 |
| 44 | 52 | 37 | 98 | 46 | 86 | 1.2003 | 1.2020 | 1.2026 | 32 | 39 |
| 41 | 83 | 68 | 1.1929 | 77 | 1.2017 | 34 | 51 | 57 | 64 | 70 |
| 38 | 1.1814 | 1.1900 | 60 | 1.2008 | 48 | 65 | 82 | 88 | 95 | 1.2101 |
| 35 | 45 | 31 | 91 | 39 | 79 | 96 | 1.2113 | 1.2119 | 1.2126 | 32 |
| 32 | 76 | 62 | 1.2022 | 70 | 1.2110 | 1.2128 | 44 | 51 | 57 | 63 |

| Gauge press., lbs. 58+ Absolute press.... 73 | Lbs. | | | | | | | | | |
|---|------------|------------|------------|------------|------------|------------|------------|------------|------------|--------|
| | 60 + 75 | 62 + 77 | 64 + 79 | 66 + 81 | 68 + 83 | 70 + 85 | 72 + 87 | 74 + 89 | 76 + 91 | |
| 56° | 1.1920 | 1.1926 | 1.1932 | 1.1937 | 1.1943 | 1.1948 | 1.1953 | 1.1958 | 1.1963 | 1.1968 |
| 53 | 51 | 57 | 63 | 68 | 74 | 79 | 84 | 89 | 94 | 99 |
| 50 | 82 | 88 | 94 | 99 | 1.2005 | 1.2010 | 1.2015 | 1.2021 | 1.2026 | 1.2031 |
| 47 | 1.2013 | 1.2019 | 1.2025 | 1.2030 | 36 | 41 | 46 | 52 | 57 | 62 |
| 44 | 44 | 50 | 56 | 61 | 67 | 72 | 78 | 83 | 88 | 93 |
| 41 | 76 | 81 | 87 | 93 | 98 | 1.2103 | 1.2109 | 1.2114 | 1.2119 | 1.2124 |
| 38 | 1.2107 | 1.2112 | 1.2118 | 1.2124 | 1.2129 | 34 | 40 | 45 | 50 | 55 |
| 35 | 38 | 43 | 49 | 55 | 60 | 65 | 71 | 76 | 81 | 86 |
| 32 | 69 | 75 | 80 | 86 | 91 | 97 | 1.2202 | 1.2207 | 1.2212 | 1.2217 |

| Gauge press., lbs.... 78 + Absolute Press.... 93 | Lbs. | | | | | | | | | |
|---|------------|------------|------------|-------------|-------------|-------------|-------------|-------------|-------------|-------------|
| | 80 + 95 | 82 + 97 | 84 + 99 | 86 + 101 | 88 + 103 | 90 + 105 | 92 + 107 | 94 + 109 | 96 + 111 | 98 + 113 |
| 56° | 1.1973 | 1.1978 | 1.1983 | 1.1987 | 1.1992 | 1.1996 | 1.2001 | 1.2005 | 1.2010 | 1.2014 |
| 53 | 1.2004 | 1.2009 | 1.2014 | 1.2018 | 1.2023 | 1.2028 | 32 | 36 | 41 | 45 |
| 50 | 35 | 40 | 45 | 50 | 54 | 59 | 63 | 67 | 72 | 76 |
| 47 | 66 | 71 | 76 | 81 | 85 | 90 | 94 | 98 | 1.2103 | 1.2107 |
| 44 | 98 | 1.2102 | 1.2107 | 1.2112 | 1.2116 | 1.2121 | 1.2125 | 1.2130 | 34 | 38 |
| 41 | 1.2129 | 33 | 38 | 43 | 47 | 52 | 56 | 61 | 65 | 69 |
| 38 | 60 | 64 | 69 | 74 | 78 | 83 | 87 | 92 | 96 | 1.2200 |
| 35 | 91 | 96 | 1.2200 | 1.2205 | 1.2209 | 1.2214 | 1.2218 | 1.2223 | 1.2227 | 31 |
| 32 | 1.2222 | 1.2227 | 31 | 36 | 41 | 45 | 49 | 54 | 58 | 62 |

| Gauge press., lbs. 100 + Absolute press... 115 | Lbs. | | | | | | | | | |
|---|--------------|--------------|--------------|--------------|--------------|--------------|--------------|--------------|--------------|--------------|
| | 105 + 120 | 110 + 125 | 115 + 130 | 120 + 135 | 125 + 140 | 130 + 145 | 135 + 150 | 140 + 155 | 145 + 160 | 150 + 165 |
| 56° | 1.2022 | 1.2032 | 1.2042 | 1.2051 | 1.2060 | 1.2069 | 1.2078 | 1.2086 | 1.2094 | 1.2102 |
| 53 | 53 | 63 | 73 | 82 | 91 | 1.2100 | 1.2109 | 1.2117 | 1.2126 | 34 |
| 50 | 84 | 94 | 1.2104 | 1.2113 | 1.2123 | 31 | 40 | 48 | 57 | 65 |
| 47 | 1.2115 | 1.2125 | 35 | 44 | 54 | 63 | 71 | 80 | 88 | 96 |
| 44 | 46 | 56 | 66 | 76 | 85 | 94 | 1.2202 | 1.2211 | 1.2219 | 1.2227 |
| 41 | 77 | 87 | 97 | 1.2207 | 1.2216 | 1.2225 | 33 | 42 | 50 | 58 |
| 38 | 1.2208 | 1.2219 | 1.2228 | 38 | 47 | 56 | 64 | 73 | 81 | 89 |
| 35 | 40 | 50 | 59 | 69 | 78 | 87 | 95 | 1.2304 | 1.2312 | 1.2320 |
| 32 | 71 | 81 | 90 | 1.2300 | 1.2309 | 1.2318 | 1.2326 | 35 | 43 | 51 |

Chimney-draft Theory.—The commonly accepted theory of chimney-draft, based on Peclet's and Rankine's hypotheses (see Rankine's Steam-engine), is discussed by Prof. De Volson Wood in Trans. A. S. M. E., vol. xi.

Peclet represented the law of draft by the formula

$$h = \frac{u^2}{2g} \left(1 + G + \frac{fl}{m} \right),$$

in which h is the "head," defined as such a height of hot gases as, if added to the column of gases in the chimney, would produce the same pressure at the furnace as a column of outside air, of the same area of base, and a height equal to that of the chimney;

u is the required velocity of gases in the chimney;

G a constant to represent the resistance to the passage of air through the coal;

l the length of the flues and chimney;

m the mean hydraulic depth, or the area of a cross-section divided by the perimeter;

f a constant depending upon the nature of the surfaces over which the gases pass, whether smooth, or sooty and rough.

Rankine's formula (Steam-engine, p. 288), derived by giving certain values to the constants (so-called) in Peclet's formula, is

$$h = \frac{\frac{\tau_0}{\tau_2} (0.0807)}{\frac{\tau_0}{\tau_1} (0.084)} H - H = \left(0.96 \frac{\tau_1}{\tau_2} - 1 \right) H;$$

in which H = the height of the chimney in feet;

τ_0 = 493° F., absolute (temperature of melting ice);

τ_1 = absolute temperature of the gases in the chimney;

τ_2 = absolute temperature of the external air.

Prof. Wood derives from this a still more complex formula which gives the height of chimney required for burning a given quantity of coal per second, and from it he calculates the following table, showing the height of chimney required to burn respectively 24, 20, and 16 lbs. of coal per sq. ft. of grate per hour, for the several temperatures of the chimney-gases given.

Rankine's formula gives a maximum draft when $\tau = 21/12\tau_2$, or 622° F., when the outside temperature is 60°. Prof. Wood says: "This result is not a fixed value, but departures from theory in practice do not affect the result largely. There is, then, in a properly constructed chimney, properly working, a temperature giving a maximum draft,* and that temperature is not far from the value given by Rankine, although in special cases it may be 50° or 75° more or less."

* Much confusion to students of the theory of chimneys has resulted from their understanding the words maximum draft to mean maximum intensity or pres-

| Outside Air. τ_2 | Chimney-gas. | | Coal per Square Foot of Grate per Hour, lbs. | | |
|--------------------------|-----------------------|-----------------------------|--|-------|------|
| | τ_1 Absolute. | Temperature, Fahrenheit. | 24 | 20 | 16 |
| | | | Height <i>H</i> , Feet. | | |
| 520° | 700 | 239 | 250.9 | 157.6 | 67.8 |
| Absolute, or | 800 | 339 | 172.4 | 115.8 | 55.7 |
| 59° F. | 1000 | 539 | 149.1 | 100.0 | 48.7 |
| | 1100 | 639 | 148.8 | 98.9 | 48.2 |
| | 1200 | 739 | 152.0 | 100.9 | 49.1 |
| | 1400 | 939 | 159.9 | 105.7 | 51.2 |
| | 1600 | 1139 | 168.8 | 111.0 | 53.5 |
| | 2000 | 1539 | 206.5 | 132.2 | 63.0 |

All attempts to base a practical formula for chimneys upon the theoretical formulæ of Peclet and Rankine have failed on account of the impossibility of assigning correct values to the so-called "constants" *G* and *f*. (See Trans. A. S. M. E., xi. 984.)

Force or Intensity of Draft.—The force of the draft is equal to the difference between the weight of the column of hot gases inside of the chimney and the weight of a column of the external air of the same height. It is measured by a draft-gauge, usually a U tube partly filled with water, one leg connected by a pipe to the interior of the flue, and the other open to the external air. (See Fig. 112, p. 359.)

If *D* is the density of the air outside, *d* the density of the hot gas inside, in lbs. per cu. ft., *h* the height of the chimney in feet, and 0.192 the factor for converting pressure in lbs. per sq. ft. into inches of water-column, then the formula for the force of draft expressed in inches of water is,

$$F = 0.192h(D - d).$$

The density varies with the absolute temperature (see Rankine).

$$d = \frac{\tau_0}{\tau_1} 0.084; \quad D = 0.0807 \frac{\tau_0}{\tau_2},$$

where τ_0 is the absolute temperature at 32° F., = 493, τ_1 the absolute temperature of the chimney-gases, and τ_2 that of the external air. Substituting these values the formula for force of draft becomes

$$F = 0.192h \left(\frac{39.79}{\tau_2} - \frac{41.41}{\tau_1} \right) = h \left(\frac{7.64}{\tau_2} - \frac{7.95}{\tau_1} \right).$$

To find the maximum intensity of draft for any given chimney, the heated column being 600° F., and the external air 60°, multiply the height above grate in feet by .0073, and the product is the draft in inches of water.

sure of draft, as measured by a draft-gauge. It here means maximum quantity or weight of gases passed up the chimney. The maximum intensity is found only with maximum temperature, but after the temperature reaches about 622° F. the density of the gas decreases more rapidly than its velocity increases, so that the weight is a maximum about 622° F., as shown by Rankine.

HEIGHT OF WATER-COLUMN DUE TO UNBALANCED PRESSURE IN CHIMNEY 100 FEET HIGH. (*The Locomotive*, 1884.)

| Temp. in the Chimney. | Temperature of the External Air—Barometer, 14.7 lbs. per Square Inch. | | | | | | | | | | |
|-----------------------|---|------|------|------|------|------|------|------|------|------|------|
| | 0° | 10° | 20° | 30° | 40° | 50° | 60° | 70° | 80° | 90° | 100° |
| 200 | .453 | .419 | .384 | .353 | .321 | .292 | .263 | .234 | .209 | .182 | .157 |
| 220 | .488 | .453 | .419 | .388 | .355 | .326 | .298 | .269 | .244 | .217 | .192 |
| 240 | .520 | .488 | .451 | .421 | .388 | .359 | .330 | .301 | .276 | .250 | .225 |
| 260 | .555 | .528 | .484 | .453 | .420 | .392 | .363 | .334 | .309 | .282 | .257 |
| 280 | .584 | .549 | .515 | .482 | .451 | .422 | .394 | .365 | .340 | .313 | .288 |
| 300 | .611 | .576 | .541 | .511 | .478 | .449 | .420 | .392 | .367 | .340 | .315 |
| 320 | .637 | .603 | .568 | .538 | .505 | .476 | .447 | .419 | .394 | .367 | .342 |
| 340 | .662 | .638 | .593 | .563 | .530 | .501 | .472 | .443 | .419 | .392 | .367 |
| 360 | .687 | .653 | .618 | .588 | .555 | .526 | .497 | .468 | .444 | .417 | .392 |
| 380 | .710 | .676 | .641 | .611 | .578 | .549 | .520 | .492 | .467 | .440 | .415 |
| 400 | .732 | .697 | .662 | .632 | .598 | .570 | .541 | .513 | .488 | .461 | .436 |
| 420 | .754 | .718 | .684 | .653 | .620 | .591 | .563 | .534 | .509 | .482 | .457 |
| 440 | .773 | .739 | .705 | .674 | .641 | .612 | .584 | .555 | .530 | .503 | .478 |
| 460 | .793 | .758 | .724 | .694 | .660 | .632 | .603 | .574 | .549 | .522 | .497 |
| 480 | .810 | .776 | .741 | .710 | .678 | .649 | .620 | .591 | .566 | .540 | .515 |
| 500 | .829 | .791 | .760 | .730 | .697 | .669 | .639 | .610 | .586 | .559 | .534 |

For any other height of chimney than 100 ft. the height of water-column is found by simple proportion, the height of water-column being directly proportional to the height of chimney.

The calculations have been made for a chimney 100 ft. high, with various temperatures outside and inside of the flue, and on the supposition that the temperature of the chimney is uniform from top to bottom. This is the basis on which all calculations respecting the draft-power of chimneys have been made by Rankine and other writers, but it is very far from the truth in most cases. The difference will be shown by comparing the reading of the draft-gauge with the table given. In one case a chimney 122 ft. high showed a temperature at the base of 320°, and at the top of 230°.

Box, in his "Treatise on Heat," gives the following table:

DRAFT POWERS OF CHIMNEYS, ETC., WITH THE INTERNAL AIR AT 552° AND THE EXTERNAL AIR AT 62°, AND WITH THE DAMPER NEARLY CLOSED.

| Height of Chimney in Feet. | Draft Power in ins. of Water. | Theoretical Velocity in Feet per Second. | | Height of Chimney in Feet. | Draft Power in ins. of Water. | Theoretical Velocity in Feet per Second. | |
|----------------------------|-------------------------------|--|------------------|----------------------------|-------------------------------|--|------------------|
| | | Cold Air Entering. | Hot Air at Exit. | | | Cold Air Entering. | Hot Air at Exit. |
| 10 | .073 | 17.8 | 35.6 | 80 | .585 | 50.6 | 101.2 |
| 20 | .146 | 25.3 | 50.6 | 90 | .657 | 53.7 | 107.4 |
| 30 | .219 | 31.0 | 62.0 | 100 | .730 | 56.5 | 113.0 |
| 40 | .292 | 35.7 | 71.4 | 120 | .876 | 62.0 | 124.0 |
| 50 | .365 | 40.0 | 80.0 | 150 | 1.095 | 69.3 | 138.6 |
| 60 | .438 | 43.8 | 87.6 | 175 | 1.277 | 74.3 | 149.6 |
| 70 | .511 | 47.3 | 94.6 | 200 | 1.460 | 80.0 | 160.0 |

Rate of Combustion Due to Height of Chimney.—Trowbridge's "Heat and Heat-engines" gives the following table showing the heights of chimney for producing certain rates of combustion per sq. ft. of section of the chimney. It may be approximately true for

| Heights in Feet. | Lbs. of Coal Burned per Hour per Square Foot of Section of Chimney. | Lbs. of Coal Burned per Square Foot of Grate, the Ratio of Grate to Section of Chimney being 8 to 1 | Heights in Feet. | Lbs. of Coal Burned per Hour per Square Foot of Section of Chimney. | Lbs. of Coal Burned per Square Foot of Grate, the Ratio of Grate to Section of Chimney being 8 to 1. |
|------------------|---|---|------------------|---|--|
| 20 | 60 | 7.5 | 70 | 126 | 15.8 |
| 25 | 68 | 8.5 | 75 | 131 | 16.4 |
| 30 | 76 | 9.5 | 80 | 135 | 16.9 |
| 35 | 84 | 10.5 | 85 | 139 | 17.4 |
| 40 | 93 | 11.6 | 90 | 144 | 18.0 |
| 45 | 99 | 12.4 | 95 | 148 | 18.5 |
| 50 | 105 | 13.1 | 100 | 152 | 19.0 |
| 55 | 111 | 13.8 | 105 | 156 | 19.5 |
| 60 | 116 | 14.5 | 110 | 160 | 20.0 |
| 65 | 121 | 15.1 | | | |

anthracite in moderate and large sizes, but greater heights than are given in the table are needed to secure the given rates of combustion with small sizes of anthracite, and for bituminous coal smaller heights will suffice if the coal is reasonably free from ash—5 per cent or less.

Thurston's rule for rate of combustion effected by a given height of chimney (Trans. A. S. M. E., xi. 991) is: Subtract 1 from twice the square root of the height and the result is the rate of combustion in pounds per square foot of grate per hour, for anthracite. Or rate $= 2\sqrt{h} - 1$, in which h is the height in feet. This rule gives the following:

| | | | | | | | | | | | |
|-------------------|-------|-------|-------|-------|-------|-----|-------|-------|-------|-------|-------|
| $h =$ | 50 | 60 | 70 | 80 | 90 | 100 | 110 | 125 | 150 | 175 | 200 |
| $2\sqrt{h} - 1 =$ | 13.14 | 14.49 | 15.73 | 16.89 | 17.97 | 19 | 19.97 | 21.36 | 23.49 | 25.45 | 27.28 |

The results agree closely with Trowbridge's table given above. In practice the high rates of combustion for high chimneys given by the formula are not generally obtained for the reason that with high chimneys there are usually long horizontal flues serving many boilers, and the friction and the interference of currents from the several boilers are apt to cause the intensity of draft in the branch flues leading to each boiler to be much less than that at the base of the chimney. The draft of each boiler is also usually restricted by a damper and by bends in the gas-passages. In a battery of several boilers connected to a chimney 150 ft. high, the author found a draft of $\frac{3}{4}$ -in. water-column at the boiler nearest the chimney, and only $\frac{1}{4}$ -in. at the boiler farthest away. The first boiler was wasting fuel from too high temperature of the chimney-gases, 900°, having too large a grate-surface for the draft, and the last boiler was working below its rated capacity and with poor economy, on account of insufficient draft.

The effect of changing the length of the flue leading into a chimney 60 ft. high and 2 ft. 9 ins. square is given in the following table, from Box on "Heat":

| Length of Flue in Feet. | Horse-power. | Length of Flue in Feet. | Horse-power. |
|-------------------------|--------------|-------------------------|--------------|
| 50 | 107.6 | 800 | 56.1 |
| 100 | 100.0 | 1,000 | 51.4 |
| 200 | 85.3 | 1,500 | 43.3 |
| 400 | 70.8 | 2,000 | 38.2 |
| 600 | 62.5 | 3,000 | 31.7 |

The temperature of the gases in this chimney was assumed to be 552° F., and that of the atmosphere 62°.

High Chimneys not Necessary.—Chimneys above 150 ft. in height are very costly, and their increased cost is rarely justified by increased efficiency. In recent practice it has become somewhat common to build two or more smaller chimneys instead of one large one. A notable example is the Spreckels Sugar Refinery in Philadelphia, where three separate chimneys are used for one boiler-plant of 7500 H.P. The three chimneys are said to have cost several thousand dollars less than a single chimney of their combined capacity would have cost. Very tall chimneys have been characterized by one writer as "monuments to the folly of their builders."

Height of Chimney required for Different Fuels.—The minimum height necessary varies with the fuel, wood requiring the least, then good bituminous coal, and fine sizes of anthracite the greatest. It also varies with the character of the boiler—the smaller and more circuitous the gas-passages the higher the stack required; also with the number of boilers, a single boiler requiring less height than several that discharge into a horizontal flue. No general rule can be given.

Size of Chimneys corresponding to Given Capacity of Boilers.—The formula given below, and the table calculated therefrom for chimneys up to 96 ins. diameter and 200 ft. high were first published by the author in 1884 (Trans. A. S. M. E., vi. 81). They have met with much approval since that date by engineers who have used them, and have been frequently published in boiler-makers' catalogues and elsewhere. The table is now extended to cover chimneys up to 12 ft. diameter and 300 ft. high. The sizes corresponding to the given commercial horse-powers are believed to be ample for all cases in which the draft areas through the boiler-flues and connections are sufficient, say not less than 20 per cent greater than the area of the chimney, and in which the draft between the boilers and chimney is not checked by long horizontal passages and right-angled bends.

Note that the figures in the table correspond to a coal consumption of 5 lbs. of coal per horse-power per hour. This liberal allowance is made to cover the contingencies of poor coal being used, and of the boilers being driven beyond their rated capacity. In large plants,

with economical boilers and engines, good fuel and other favorable conditions, which will reduce the maximum rate of coal consumption at any one time to less than 5 lbs. per H.P. per hour, the figures in the table may be multiplied by the ratio of 5 to the maximum expected coal consumption per H.P. per hour. Thus, with conditions which make the maximum coal consumption only 2.5 lbs. per hour, the chimney 300 ft. high \times 12 ft. diameter should be sufficient for $6155 \times 2 = 12,310$ horse-power. The formula is based on the following data:

1. The draft-power of the chimney varies as the square root of the height.

2. The retarding of the ascending gases by friction may be considered as equivalent to a diminution of the area of the chimney, or to a lining of the chimney by a layer of gas which has no velocity. The thickness of this lining is assumed to be 2 ins. for all chimneys, or the diminution of area equal to the perimeter \times 2 ins. (neglecting the overlapping of the corners of the lining). Let D = diameter in feet, A = area, and E = effective area in square feet.

$$\text{For square chimneys, } E = D^2 - \frac{8D}{12} = A - \frac{2}{3} \sqrt{A}.$$

$$\text{For round chimneys, } E = \frac{\pi}{4} \left(D^2 - \frac{8D}{12} \right) = A - 0.591 \sqrt{A}.$$

For simplifying calculations, the coefficient of \sqrt{A} may be taken as 0.6 for both square and round chimneys, and the formula becomes

$$E = A - 0.6 \sqrt{A}.$$

3. The power varies directly as this effective area E .

4. A chimney should be proportioned so as to be capable of giving sufficient draft to cause the boiler to develop much more than its rated power, in case of emergencies, or to cause the combustion of 5 lbs. of fuel per rated horse-power of boiler per hour.

5. The power of the chimney varying directly as the effective area, E , and as the square root of the height, H , the formula for horse-power of boiler for a given size of chimney will take the form H.P. = $CE \sqrt{H}$, in which C is a constant, the average value of which, obtained by plotting the results obtained from numerous examples in practice, the author finds to be 3.33.

The formula for horse-power then is

$$\text{H.P.} = 3.33 E \sqrt{H}, \quad \text{or} \quad \text{H.P.} = 3.33 (A - 0.6 \sqrt{A}) \sqrt{H}.$$

If the horse-power of boiler is given, to find the size of chimney, the height being assumed,

$$E = \frac{0.3 \text{ H.P.}}{\sqrt{H}}; = A - 0.6 \sqrt{A}.$$

For round chimneys, diameter of chimney = diam. of $E + 4$ ins.

For square chimneys, side of chimney = $\sqrt{E} + 4$ ins.

If effective area E is taken in square feet, the diameter in inches is $d = 13.54 \sqrt{E} + 4$ ins., and the side of a square chimney in inches is $s = 12 \sqrt{E} + 4$ ins.

If horse-power is given and area assumed, the height $H = \left(\frac{0.3 \text{H.P.}}{E} \right)^2$.

In proportioning chimneys the height is generally first assumed, with due consideration to the heights of surrounding buildings or hills near to the proposed chimney, the length of horizontal flues, the character of coal to be used, etc., and then the diameter required for the assumed height and horse-power is calculated by the formula or taken from the table.

CHAPTER XVII.

MISCELLANEOUS.

ECONOMIZERS.—APPARATUS FOR INDICATING FURNACE CONDITIONS.—THE ARNDT ECONOMETER.—FLUE-GAS ANALYSES AND THE HEAT BALANCE.—DESIGNING BOILERS FOR A STREET-RAILWAY PLANT.—LOSS OF FUEL DUE TO KEEPING UP STEAM-PRESSURE IN IDLE BOILERS.—COAL USED IN BANKED FIRES NOT A MEASURE OF RADIATION.—COST OF COAL PER BOILER HORSE-POWER PER YEAR.—BOILER-ROOM LABOR.—STEAM-BOILER PRACTICE OF THE FUTURE.

Economizers.—The Green economizer, Fig. 131, consists of a rectangular chamber of brickwork filled with a great number of vertical cast-iron water-tubes. The waste heat from the cylinder boiler is carried into this chamber before being allowed to enter the chimney, and heats the feed-water, which passes through the tubes under pressure, to a temperature approaching that of the steam generated in the boiler. This economizer is very commonly used in England with Lancashire boilers, and has been largely introduced in this country, especially in large plants such as sugar refineries. The advisability of its use in any particular case is a matter of close calculation, in which the factors are quantity of coal used and of water evaporated by the boilers, temperature of the feed-water, temperature of the waste gases from the boiler, cost of the economizer, annual cost for interest and probable repairs, and probable saving by the economizer.

Data for Proportioning a Green Economizer.—The Fuel Economizer Co. makes the following statement concerning the amount of heating surface to be provided in an economizer to be used in connection with a given amount of boilers, and concerning the results which may be expected from the economizer:

We have found in practice that by allowing 4 sq. ft. of heating surface per boiler horse-power ($34\frac{1}{2}$ lbs. of water evaporated from and at $212^{\circ} = 1$ H.P.), we are able to raise the feed-water 60° for every 100° reduction in the temperature, entering the economizer with gases from 450° to 600° .

With temperature entering the economizer at 600° to 700° we have allowed a heating surface of $4\frac{1}{2}$ to 5 sq. ft. of heating surface per

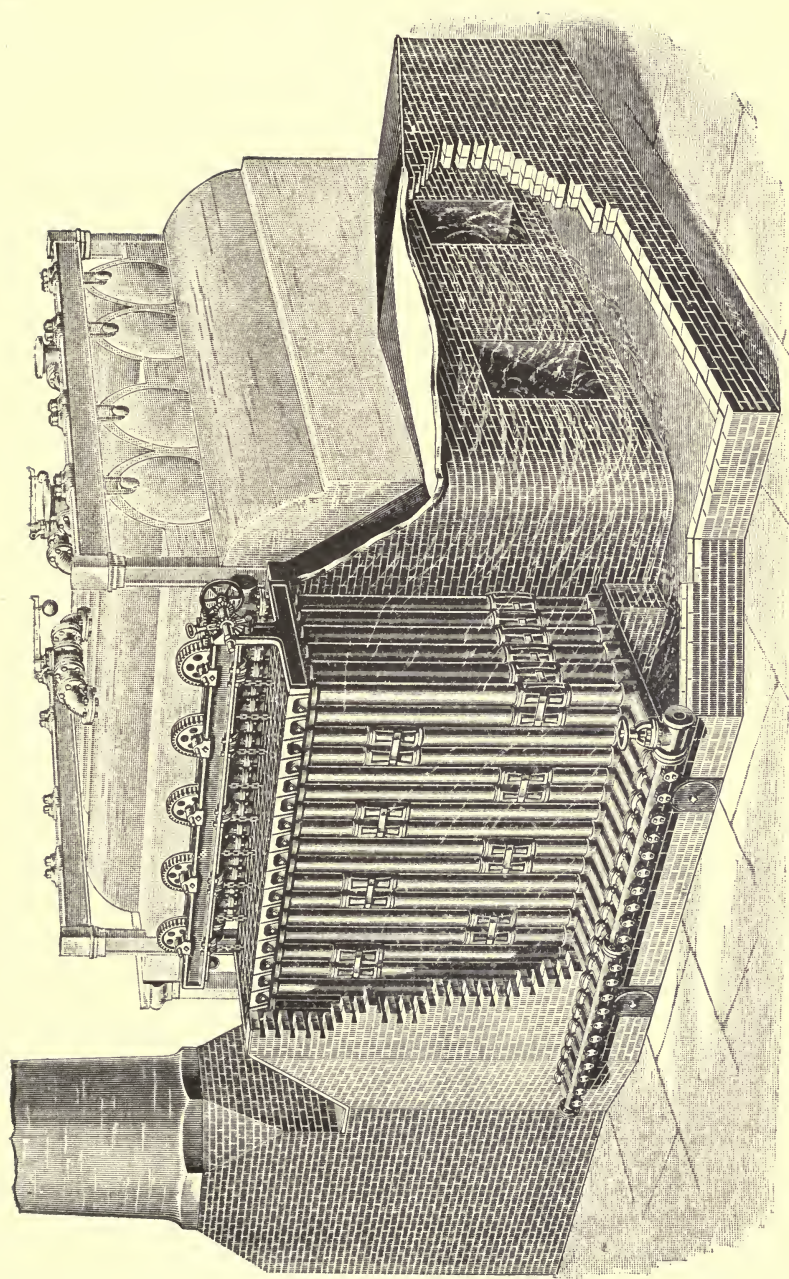

FIG. 131.—THE GREEN ECONOMIZER.

boiler horse-power, and for every 100° reduction of gases we have obtained about 65° rise in temperature of the water; the temperature of the feed-water entering averaging from 60° to 120°.

With 5000 sq. ft. of boiler heating surface (plain cylinder boilers) developing 1000 H.P., we should recommend using 5 sq. ft. of economizer heating surface per boiler H.P., or an economizer of about 500 tubes, and it should heat the feed-water about 300°.

Calculation of the Saving Effected by an Economizer.—If there were no loss by radiation from the economizer, and no leakage of air into its brick setting, the heat lost by the gases in passing through it, as measured by their difference in temperature on entering and leaving, would exactly equal the heat added by the economizer to the feed-water. The following calculation is based on this assumption:

Suppose the heating value of 1 lb. of fuel to be 14,400 B.T.U.; that it is thoroughly burned with about 24 lbs. of air, making 25 lbs. of gas per pound fuel; that the boiler absorbs 70 per cent of the heat generated, and the economizer 40 per cent of the remainder, making the efficiency of the boiler and economizer combined 82 per cent; and the loss of heat in the chimney-gases, including radiation from the boiler, 18 per cent.

| | | | |
|--|--|--------|------|
| Temperature * of the fire..... | $\frac{14,400}{25 \times 0.24} = 2400$ | | |
| Temperature * of gases leaving boiler..... | 2400×0.30 | | 720° |
| “ “ “ “ economizer..... | 720×0.60 | | 432° |
| | B.T.U. | U.E.† | % |
| Heating value of the fuel per lb..... | 14,400 | 14.90 | 100 |
| Absorbed by the boiler per lb. fuel.... | 10,080 | 10.43 | 70 |
| Absorbed by the economizer..... | 1,728 | 1.788 | 12 |
| Remainder, escapes into chimney..... | 2,592 | 2.682 | 18 |
| Useful effect, boiler and economizer..... | 11,808 | 12.218 | 82 |
| Temperature of feed-water entering economizer.... | 62°; B.T.U. above 32° | | 30 |
| Steam-pressure, 130 lbs. gauge; temperature..... | = 355°; “ “ | | 327 |
| Total heat of 1 lb. steam 1190.4 B.T.U.; latent heat, | 862 B.T.U. | | |
| Factor of evaporation 62° to 130 lbs. = 1.20 | | | |
| Water evaporated per lb. fuel, $12.218 \div 1.2 = 10.182$ lbs. | | | |
| $1728 \div 10.182 = 169.7$ B.T.U. added to each 1 lb. water by the economizer. | | | |
| $10,080 \div 10.182 = 990.0$ “ “ “ “ “ “ “ “ boiler. | | | |
| $169.7 + 30 = 199.7$ B.T.U. in 1 lb. water entering boiler, = 230° F | | | |

Of the 990 B.T.U. added to each 1 lb. water by the boiler, $327 - 199.7 = 127.3$ B.T.U. is used in raising its temperature from

* Temperatures measured above the atmospheric temperature.

† Units of Evaporation = lbs. evaporated from and at 212°.

230° to 355°, and 862.7 B.T.U. to evaporate it at that temperature.

The heat gained by the economizer is

$$\frac{12}{70} \quad \text{or} \quad \frac{169.7}{990} = 17.14 \text{ per cent.}$$

The saving of fuel is

$$\frac{12}{70 + 12} \quad \text{or} \quad \frac{169.7}{1160} = 14.63 \text{ per cent.}$$

Expressed in the shape of a formula:

$$\text{Saving of fuel} = \frac{\text{Heat added to each lb. of water by the economizer}}{\text{Heat added to each lb. of water by both boiler and economizer}}$$

The above is the usual method of calculating the saving of fuel due to the use of an economizer. It is a correct method when the problem to be solved is like the following: "What will the fuel saving be when a plant is provided with both boiler and economizer, giving a combined efficiency of 82 per cent, as compared with a plant provided with boilers alone, giving an efficiency of 70 per cent?"

It is incorrect, however, when the problem is of a different nature, such as the following: "A plant has boilers and economizers running as in the above example, the boiler utilizing 70 per cent and the economizer 12 per cent of the heating value of the fuel; what is the saving of fuel by the use of the economizer as compared with the fuel that would be used by the same boilers delivering the same amount of steam without the economizer?"

In this case it is evident that the boilers will be driven harder if they have to do the work of the economizer in addition to their own; more coal will be burned, the gases will escape at a higher temperature, and the efficiency of the boiler will be lower. It is necessary in this case to know the rate at which the efficiency of the boiler decreases with increased rate of driving, or the "efficiency curve" of the boiler. From the data in the above example, we may make an approximate estimate of the rate of decrease of efficiency, using a formula given in the chapter on "Efficiency of Heating Surface," neglecting the loss by radiation, as unimportant.

The formula is $E'_a = BE_p - A \frac{W'}{S}$, in which E'_a = evaporation per pound of fuel from and at 212°; E_p = possible evaporation = heating value of the fuel \div 965.7; W' = water evaporated per hour; S = square feet of heating surface; $B = (T_1 - t) \div T_1$; T_1 = temperature of the fire and t the temperature of the water and steam in

the boiler, both being measured above the atmospheric temperature; $A = acf \div (T_1 - t)$, a being the coefficient of efficiency of the heating surface, c the specific heat of the gases, and f the weight of gas per pound fuel. For the example given we have: $E_a' = 10.43$; $E_p = 14.90$; $T_1 = 2400$; $t = 293$; $B = 0.88$; $f = 25$; $c = 0.24$; $a = 200$, for good boiler practice; $A = 0.57$; $E_a' = BE_p - A \frac{W'}{S}$; $10.43 = 0.88 \times 14.90 - 0.57 \frac{W'}{S}$; whence $\frac{W'}{S} = 4.7$ lbs. water evaporated from and at 212° per sq. ft. of heating surface per hour. This is the rate of "equivalent evaporation" of the boiler when it has the economizer attached, and is utilizing 70 per cent of the heating-value of the fuel. Suppose now the economizer is disconnected and the boiler is required to do the whole work. Its equivalent evaporation must then be increased in the ratio of 82 to 70, or to $4.7 \times 82 \div 70 = 5.51$ lbs. Substituting this value of $\frac{W'}{S}$ in the formula we have $E_a = 14.90 \times 0.88 - 0.57 \times 5.51 = 9.97$ lbs., and the efficiency $E_a \div E_p = 9.97 \div 14.90 = 66.9$ per cent instead of 70 per cent obtained by the boiler when it was run with the economizer.

The saving by the use of the economizer in this case is $\frac{82 - 66.9}{82} = 18.41$ per cent, instead of 14.63 per cent, the result obtained in the first example.

Apparatus for Indicating Furnace Conditions.—It has been shown in Chapter IX that the efficiency of a steam-boiler depends largely upon the air-supply, or in other words upon the number of pounds of gases of combustion per pound of carbon. It is found by experiment that the highest efficiencies are obtained when the weight of gas is from 19 to 20 lbs. per pound of carbon. This corresponds approximately to a gas containing about 15 per cent CO_2 , 5 per cent O, 80 per cent N, and no CO. A smaller air-supply, giving fewer pounds of gas per pound of carbon, will not be sufficient to maintain complete combustion, and will cause more or less CO to be in the gas. A greater air-supply, increasing the weight of gas per pound of carbon, means a greater loss of heat in the chimney-gases, which will then be high in O and low in CO_2 . As has already been stated it is a matter of the utmost difficulty, with ordinary firing, to regulate the air-supply so as to maintain the gas at the proper composition.

Maximum economy, as far as the operation of the furnace is con-

cerned, is coincident with maximum furnace temperature, also with the gases of combustion containing from 14 to 16 per cent CO_2 and from 5 to 7 per cent O. If there could be a continuous record conveniently made either of the furnace temperature, or of the percentage of CO_2 or of O in the gases, so that the fireman could observe this record and know the condition of his furnace as easily and as accurately as he knows the steam-pressure by consulting his steam-gauge, the average boiler efficiency in ordinary practice might be raised 10 or 20 per cent, and a great saving of fuel thereby be made.

For measuring furnace temperatures there are now available the La Chatelier electrical pyrometer, the Uehling & Steinbart pneumatic pyrometer, and the Bristol air-thermometer.*

For continuously indicating the percentage of CO_2 in the gases

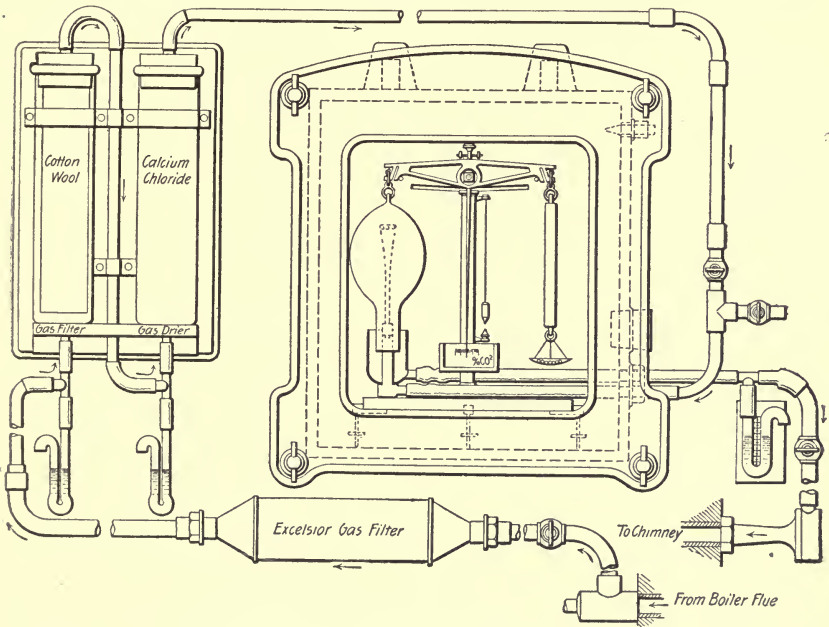

FIG. 132.—THE ARNDT ECONOMETER.

there are the Uehling & Steinbart gas composimeter and the Arndt econometer, a recent German invention.† A brief description of this instrument is given below, and it is illustrated in Fig. 132.

* For further information concerning these instruments consult the circulars of the manufacturers. The American agent of the electrical pyrometer is Chas. Engelhard, 41 Cortlandt Street, New York. Uehling & Steinbart's address is Carlstadt, N. J., and the Bristol Mfg. Co.'s is Waterbury, Conn.

† Joseph Wilckes, Agent, 106 Fulton Street, New York.

The Arndt Econometer.—This apparatus consists essentially of a delicate balance which continually weighs the flue-gases, and thus indicates their composition. Carbonic acid gas is 52 per cent heavier than air; the weight of the flue-gases thus depends upon the amount of carbonic acid gas they contain, and the weight is an index of the composition. The gas is drawn from the furnace-flue through a small-sized pipe and passes first through two gas-filters, a coarse and a fine. The purpose of these filters is to remove the dust, which, if allowed to pass on, would accumulate in the weighing apparatus and vitiate the results. The first filter is placed as near as may be to the boiler, in order to prevent the dust passing on and obstructing the pipes. After passing the second filter, the gas passes through a drier which is filled with calcium chloride to absorb the moisture. Passing from the drier through the connecting-pipes, the gas is finally discharged through a rose-head into the gas-holder, which is a balloon-shaped vessel of glass, its open mouth hanging within the glass cup. From the cup the gas is drawn through the connecting-pipe which connects with the chimney through an aspirator if necessary. There is thus a constant circulation of gas through the instrument, and the gas-holder is constantly filled with gas representing the product of the furnace. The gas-holder, as will be seen, is hung from one end of a delicate balance, whose pointer moves over a scale which is graduated so as to indicate directly the percentage of carbonic acid. The scale is mounted in a cast-iron box with a glass front which is airtight except for a small air-inlet. It is essential that the box be filled with atmospheric air, and the regulating cocks are so adjusted that the draft through the tube constantly draws the air from the case, and so insures that it shall be filled with air only.

A suitable supply of air gives from 12 to 15 per cent of carbonic acid in the flue-gas, and any deficiency in that percentage indicates that too much air is being admitted.

Flue-gas Analyses and the Heat-balance.—In the heat-balance computed from the results of a boiler-test—see Chapter XIV, pages 342 and 359—the heat which is “unaccounted for” sometimes amounts to quite a large percentage of the total heating value of the coal. In one case, with soft coal very high in moisture, the author found it to be more than 20 per cent, even after a liberal allowance had been made for radiation. Some probable causes of this shortage in the heat-balance are the following:

1. The calculations of heat lost in the chimney-gas are based on the supposition that the dry gas contains only CO_2 , CO , O , and N . The fact is that for a short period after each firing of fresh coal the gas may also contain H , formed by decomposing the moisture in the coal, and CH_4 , distilled from the coal, which are not burned because the furnace conditions were unfavorable. The gas may also contain some SO_2 and NO_2 , from the sulphur and the nitrogen in the coal. As much as 1.37 per cent of NO_2 has been found in chimney-gases by Dr. A. H. Gill.* This would indicate the possibility that a small

* *Engineering News*, Feb. 18, 1897, p. 107.

quantity of oxides of nitrogen may be produced from the nitrogen of the air in the boiler-furnace.

2. The gas analyzed may not be a fair average sample of the gas in the flue. The constitution of gas produced in an ordinary furnace is constantly varying; within a space of ten minutes it may vary from low CO_2 , high CO , and no O , through high CO_2 , no CO , and low O , to low CO_2 , no CO , and high O . The gas is also apt to vary in composition in different parts of the flue. See "Sampling Flue-gases," page 365.

3. The analysis for CO_2 , CO , O , and N (by difference) may be erroneous. Sometimes analyses are published which show the total of CO_2 , CO , and O to be only about 16 per cent. It is very improbable that the sum of these gases can ever be as low as 16 per cent in boiler practice, except possibly for a minute or so after firing fresh coal, when large volumes of H and of CH_4 may be given off. When carbon is thoroughly burned to CO_2 , either with or without excess of air, the sum of CO_2 and O should equal 20.9 per cent, and the N 79.1 of the volume of the gases. Carbon burned to CO only, without excess of air would give a gas containing 34.5 per cent CO and 65.5 per cent N . Hydrogen burned in air without excess would give a dry gas of 100 per cent N . The normal value of the sum of CO_2 and O being 20.9 per cent, and the production of CO by imperfect combustion tending to make the sum of CO_2 , CO , and O higher than this figure, it would require the burning of a large percentage of hydrogen, or the dilution of the gas by a large volume of hydrocarbons, to reduce the sum of CO_2 , CO , and O to as low a figure as 16. If the sum is below 19, an error in the analysis may be suspected.

Designing Boilers for a Small Street-railway Plant.*—In entering upon the studies preliminary to the design of the steam-boilers for a small or medium-sized electrical street-railway power-plant the engineer must take into consideration some peculiar features of the service required from the boilers which differ more or less from those which govern the design of boilers for other purposes, such as a factory. Such features are: the extreme variations of the load upon the engines from hour to hour, and the consequent variation in the quantity of steam to be furnished; the prime necessity of having the boiler-plant constantly in condition to furnish the maximum amount of steam required during the

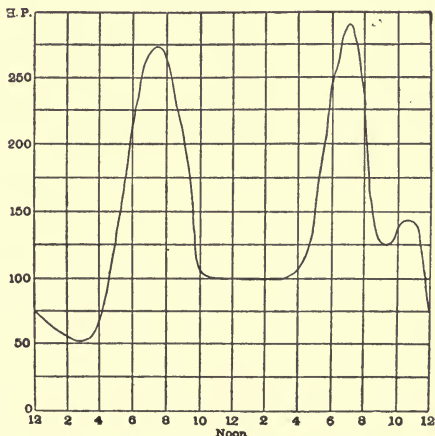

FIG. 133.—LOAD-DIAGRAM OF A STREET-RAILWAY PLANT.

* From an article by the author in *Street Railway Review*, February, 1899.

hours of heaviest load; the absence of holidays or slack seasons during which general repairs or alterations may be made; and the considerable uncertainty that exists before the plant is put in operation concerning the actual amount of power that may be required and the probable additions that may be needed as the road is extended or as traffic increases. The first considerations, therefore, in the design of the boiler-plant are certainty of operation under the severest load, and capacity for furnishing the maximum amount of steam that may be needed under the most adverse conditions, such as a combination of heaviest load, bad weather, poor coal, and a portion of the boiler-plant being laid off for cleaning or repairs.

To meet these requirements it is necessary not only to have the boilers of sufficient capacity to meet the greatest demand for steam, but also to have enough boilers to allow one of them to be laid off without curtailing the steam-supply below the maximum quantity that may at any time be required by the engines. In even the smallest-sized plant it is advisable to have not less than three boilers, any two of which are able to run the plant at the time of heaviest loading. In larger plants, four, five, or more boilers may be installed, and arranged that any one of them may be laid off at any time for cleaning or repairs without interfering with the operation of the others.

Assuming that the boiler-plant is to contain one boiler more than is sufficient to generate the steam required under the conditions of maximum load, the poorest coal being supplied that is ever expected to be used at the station, and the weather the most unfavorable as regards the draft and the amount of moisture in the air and in the coal, we proceed to consider the number, size, proportions, and style of the boilers to be selected.

The boiler-plant is usually one of the last of the divisions of the complete power-plant that are to be designed. Before designing it we must know the maximum quantity of steam that will be needed. The electrical engineer of the railway company will furnish data as to the electrical horse-power that will be required from the dynamos, and he will hand to the steam engineer a diagram something like the one shown in the accompanying cut, Fig. 133, giving the heaviest loads expected on the dynamos during twenty-four hours. From these data the steam-engines will be selected or designed, involving a long study of the relative advantages and disadvantages of horizontal and vertical, of simple and compound, of condensing and non-condensing engines, of their size and of their probable steam-consumption at different loads. The two "peaks" of the load-diagram will be carefully considered, and the question will be decided whether these peaks are to be taken care of by storage-batteries, by overloading the engines or dynamos, or by the use of a separate engine and dynamo to be operated during three or four hours of the day when the load is heaviest.

The steam-engine questions being decided, a careful calculation is

then made of the probable steam consumption per hour during the single hour or fraction of an hour of maximum load, having due consideration for the fact that an overloaded engine may be very wasteful of steam. How wasteful will depend on the type of engine. Not until this question is settled is it time to prepare the design of the boiler-plant.

The boilers, after one of them is reserved for cleaning or repairs, must be capable of furnishing sufficient steam to the engines during the time of the peak of the load, even when the coal is poor and the weather bad, and the engine not in its best condition as to steam-tightness and valve-adjustment; and to this consideration every other one, such as first cost of boilers, or economy of coal, must be made secondary.

The maximum number of pounds of steam per hour now being given, and the pressure of steam required by the engines and the probable feed-water temperature being known, we have the data with which to begin figuring on the boilers. By referring to a table of "factors of evaporation," we may reduce this number to the equivalent number of pounds per hour evaporated "from and at 212° F." Dividing this by $34\frac{1}{2}$ gives the number of "boiler horse-power." A slight allowance, say 1 per cent, may be added to cover loss of heat due to radiation from the steam-pipes.

Having the amount of work to be done by the boilers during the time of the peak of the load, we now consider how this capacity is to be obtained. The first essential in a boiler is its capacity to burn coal. No matter what its type or proportions, or the extent of its heating surface, it will not develop the required power unless it can burn enough coal. This qualification strictly does not belong to the boiler itself, but chiefly to the furnace under the boiler, and largely to the chimney, to the area of flues or gas-passages through or beyond the boiler, and to the quality of the coal. We must therefore proportion the furnace before we proportion the boiler, and to do this we must first find out how many pounds of coal are to be burned per hour during the time of maximum steam demand. This is rather a complex question, for it involves many variable elements, such as the quality of the coal, the kind of furnace, the rate of driving of the boiler, and the skill of the fireman.

The number of pounds of coal required per hour will be equal to the quotient obtained by dividing the equivalent evaporation from and at 212° per hour, in pounds by the number of pounds of water that may be evaporated from and at 212° by 1 lb. of coal. This latter number will vary anywhere from 12, when the best grade of semi-bituminous coal, low in ash, is used, in a furnace adapted to burn all the volatile part of the coal, with a boiler so proportioned as to be capable of absorbing 75 per cent of the heat generated in the furnace, and with skilful firing, down to 5 lbs. or less, with a poor grade of western bituminous coal, high in moisture, ash, and sulphur, burned in an ordinary furnace directly under the boiler, with no provision for burning the volatile matter or preventing smoke, with a boiler

having insufficient heating surface, and therefore overdriven, and with unskilful firing. With lignite, or lignitic coal, from Utah, a figure as low as 3.79 lbs. has been obtained. (Trans. A. S. M. E., vol. iv. p. 263.) The writer once obtained as low as 5.09 lbs. from a poor quality of Illinois coal, with expert firing, with the boiler driven 16 per cent below its rating, but with both the furnace and the grate-bars unsuited to the coal. (Trans. A. S. M. E., vol. iv. p. 267.)

It may be estimated that with any kind of coal the evaporation per pound of coal will be in the neighborhood of 15 per cent less with a rate of driving of 6 lbs. of water from and at 212° per square foot of heating surface per hour than at a rate of 3 lbs., the rate for maximum economy.

Extent of Heating Surface Required.—For factory boilers, or for any boilers that are to be driven at a uniform rate throughout the day, the boilers should be so proportioned that the rate of driving should not exceed 3 lbs. of water from and at 212° per square foot of heating surface per hour; the extra cost of coal for driving at a more rapid rate usually being greater than the interest on the extra investment necessary to secure a sufficient extent of heating surface over and above that required for more rapid rates of driving.

With boilers for electric street-railway service, however, the case is entirely different. The heavy load upon the boiler-plant lasts for only about two hours out of the twenty-four, and unless money is very cheap and coal very dear, it will usually pay to sacrifice say 15 per cent of economy during those two hours rather than go to the expense necessary to proportion the boilers so that they will be driven at their most economical rate during those two hours. It is also to be considered that the extra boiler which is to be put in the plant so that any one boiler may at any time be laid off for cleaning or repairs may be used most of the time, since repairs and cleaning are not required often, so that all the boilers may be in service during the time of the peak of the load for a large proportion of the days in the year, and the excessive rate of driving during the time of the peak of the load may thus be diminished.

It will therefore not be bad designing if the extent of heating surface is proportioned so as to allow of the boilers, after one is laid off for cleaning or repairs, to be driven at a rate of 6 lbs. of water evaporated from and at 212° per square foot of heating surface per hour during the time of the peak of the load, provided that no mistake has been made in estimating the quantity of steam needed during that time, due consideration being had to the fact that the engines are wasteful of steam when overloaded, as they are likely to be during that time, and provided also that sufficient coal-burning capacity is provided in the furnaces, so that enough coal may be burned, including the 15 per cent wasted by rapid driving, to supply this steam under the most unfavorable conditions of wet weather and of poor coal.

Assume that the steam engineer's estimates show that 600 I.H.P.

will be required to be furnished by the engines during the time of maximum load, that the engines are non-condensing, requiring 30 lbs. of steam per I.H.P. per hour at their economical load and 20 per cent more when overloaded so as to furnish the 600 I.H.P.; that the feed-water is furnished from a heater at 200° F., and that the steam-pressure is 125 lbs., we then make a calculation as follows:

| | | | |
|-------------|--------|--|--|
| | 600 | I H.P. | |
| | 30 | lbs. steam per I.H.P. per hour. | |
| | 18,000 | lbs. per hour. | |
| Add..... | 3,600 | 20 per cent for overloaded engines. | |
| | 21,600 | lbs. per hour. | |
| Mult. by... | 1.057 | factor of evaporation for feed at 200° and steam of 125 lbs. | |
| Product.... | 22,831 | lbs. equivalent evaporation from and at 212° per hour. | |
| Divide by.. | 6 | lbs. evap. per sq. ft. heating surface per hour. | |
| Quotient... | 3,805 | sq. ft. heating surface. | |

This is the very smallest amount of heating surface that should be provided for the given conditions. It may be divided among two boilers of not less than 1903 sq. ft. each, or three boilers of 1268 sq. ft. each, and in either case an additional boiler of the same size must be provided so that one boiler may be laid off. The plant will therefore contain either three boilers of 1903 sq. ft. each = 5709 sq. ft., or four boilers of 1268 sq. ft. each = 5172 sq. ft. It may be found that the three larger boilers including setting, valves, piping, etc., will cost little if any more than the four smaller boilers with their setting, etc., and it may also be considered advisable to have the three larger boilers, with their greater total extent of heating surface, to provide against the contingency of an increased amount of steam being needed by the engines.

A plant of three boilers is a favorite arrangement for a new street-railway plant, two of the boilers being set in one battery and the third singly, a space being left alongside of the third boiler for a fourth, completing two batteries, if ever it should be needed.

Now let us assume that the coal to be used is a rather low grade of Illinois coal, of a heating value of 14,300 heat-units per pound of combustible, and that it may be expected to contain occasionally as high as 18 per cent ash and 12 per cent moisture. The heating value per pound of coal will then be $14,300 \times .70 = 10,010$ heat-units. This divided by 965.7 gives 10.36 lbs. of water from and at 212° as the possible evaporation of the coal if it were completely burned and all the heat utilized by the boiler. But only a portion can be utilized, say 55 per cent, if the boiler is provided only with an ordinary setting, or say 65 per cent if it is set with a fire-brick oven, especially designed to burn the volatile gases, or if it is provided with a down-draft furnace or a mechanical stoker suitable for that grade of coal. The difference in economy between an efficiency of 55 per cent and one of 65 per

cent is not 10 per cent, as some may suppose, but $10 \div 65 = 15.4$ per cent.

We now make the following calculation:

| | Plain Furnace. | Special Furnace. |
|---|----------------|------------------|
| Heating value of 1 lb. of coal, equivalent evaporation from and at 212° | 10.36 | 10.36 |
| Efficiency of boiler and furnace | .55 | .65 |
| Product, lbs. from and at 212° | 5.698 | 6.734 |
| Deduct 15 per cent for loss due to driving the boiler at 6 lbs. per sq. ft. of heating surface per hour, or double its most economical rate | 855 | 1.010 |
| Lbs. water evaporated from and at 212°, per lb. coal. | 4.843 | 5.724 |
| Divide these figures into the figure already found for total water from and at 212° per hour. | 22,831 | 22,831 |
| Quotient, lbs. of coal per hour | 4,714 | 3,989 |

The difference, 725 lbs., is 15.4 per cent of 4714 lbs., which agrees with the economy of the more efficient furnace as above stated and checks the computation.

Extent of Grate-surface Required.—To calculate the extent of grate-surface required we must know how many pounds of coal may be burned per square foot of grate per hour. This will depend on the draft, on the kind of grate used, and on the nature of the coal as to free-burning quality and as to its clinkering on the grates and choking the air-supply. We may assume that a chimney 150 ft. high is provided, which after making allowances for bends in the flues from the boiler to the chimney will, under the most unfavorable conditions of weather, give a draft of at least 0.5 in. of water-column at the end of the boiler. The coal is free-burning, and will burn rapidly if supplied with enough air through the grate-bars, but it clinkers badly. With ordinary grates we cannot count on burning it at a faster rate than 25 lbs. per sq. ft. of grate per hour, but with shaking grates well handled, so as to keep the fire clear of clinker, a rate of 35 lbs. may be expected. We now calculate the grate-surface required as follows:

| | Plain Furnace. | Special Furnace. |
|--|----------------|------------------|
| Coal to be burned per hour, lbs. | 4,714 | 3,989 |
| Plain grates, 25 lbs. per hour, sq. ft. | 189 | 160 |
| Shaking grates, 35 lbs. per hour, sq. ft. | 135 | 114 |

With shaking grates and hard, steady firing, we may expect a loss through the grates of unburned coal amounting to about 2 per cent more than the loss through the plain grates, but as in a street-railway plant this hard firing will last only about two hours a day, we need make no change in our calculation on this account.

We thus have four different figures for the extent of grate-surface required, according to whether we use ordinary or special furnaces and ordinary or shaking grates. Dividing the heating surface already found, 3805, by these figures, we have for the ratio of heating to grate-surface the following:

| | Plain Furnace. | | Special Furnace. | |
|-------------------------------------|----------------|----------------|------------------|----------------|
| | Plain Grate. | Shaking Grate. | Plain Grate. | Shaking Grate. |
| Sq. ft. of grate..... | 189 | 135 | 160 | 114 |
| Ratio heating to grate-surface..... | 20.1 | 28.2 | 23.8 | 33.3 |

These figures for the ratio of heating to grate-surface are very much smaller than those provided in the common designs of modern boilers, especially those of the water-tube type. The ratio they give usually ranges from 35 to 50. The reason for this difference is that the data upon which the above calculations are based are very different from those upon which these boilers are designed. We have assumed a maximum rate of driving of 6 lbs. of water evaporated from and at 212° per square foot of heating surface per hour, with an intentional sacrifice of economy in order to save first cost of installation. We have also assumed a low grade of coal that clinkers on the grate, and in the case of the plain furnace a low efficiency. In the design of the ordinary water-tube boiler, especially for factory purposes, economy of coal is the first consideration. The heating surface is therefore made of such an extent that it does not require to be driven at a rate greater than 3 lbs. per sq. ft. per hour on an average, with a maximum of 4 or 4½ lbs. The boilers are by most builders rated in H.P. at the rate of 3 lbs. evaporation per square foot of heating surface per hour, and when evaporation tests are made to prove guarantees a good quality of coal is usually obtained and the boilers are driven at not above 4 lbs. per sq. ft. of heating surface per hour.

Another reason for the high ratios of heating to grate-surface in modern water-tube boilers is that when designed with a view to economy of first cost and of ground-space occupied they are made long, narrow, and high, so as to pile a great amount of heating surface on a small ground area. A narrow boiler means a narrow grate-surface, and as it is not easy for a fireman to handle with good results a grate over 7 ft. long, it means limited extent of grate-surface. This is all right for good semi-bituminous coal or for Pittsburg or Hocking Valley bituminous, which are both free-burning and low in ash. With these coals and strong draft and a ratio of heating to grate-surface of 45 or even 50 to 1, it is possible to drive the boiler to double its economical rate. For poor coals, however, whether anthracite or bituminous, such a ratio gives entirely too small a grate for rapid driving.

About three years ago, in a series of tests made by the writer on a water-tube boiler with a very poor quality of Illinois coal, with an ordinary furnace and plain grate-bars, and with a good draft, he found that only about 85 per cent of the capacity of the boiler could be developed even with expert firing. The chief troubles were the clinkering of the grates and the excessive amount of moisture in the coal, which retarded the combustion. With the same boiler provided with a fire-brick arch setting, with shaking grates, and with Hocking Valley lump coal the boiler was driven to over 170 per cent of its rating, or over 5.1 lbs. of water evaporated from and at 212° per square foot of heating-surface per hour. Had it been possible to double the extent of grate-surface when using the poor grade of coal it is quite likely that the capacity obtained could have been doubled.

Having made the calculation, as above shown, for the extent of grate-surface required under the four assumed conditions, we must next consider which one of the four results should be adopted in the design. Unless coal is very cheap it will pay to go to any reasonable expense to provide the special furnace, either a fire-brick oven built in front of the boiler with arrangements for burning the smoky gases, or a down-draft furnace, or a mechanical stoker. With any of these devices a saving of 15 per cent in fuel should be expected when the coal is a highly volatile bituminous. Shaking grates are also desirable in a street-railway plant using poor fuel, since they enable the grate to be kept free from clinker, and diminish greatly the grate-surface and therefore the ground area required.

Specifications for Bids.—Having fixed upon the extent of grate-surface that is necessary to burn the coal under the most unfavorable conditions of weather, moisture, etc., for the heaviest load, adding, of course, the grate-surface for the extra or reserve boiler, this should be entered in the specifications for bidders for boilers, and no bid should be considered which did not give the full extent called for. Many expensive mistakes have been made by purchasers of boilers who have accepted the guarantees of economy and capacity offered by builders, without reference to the extent of grate-surface. After erection the boilers may be proved to have fulfilled the guarantees, on an expert test, with good coal, but afterwards they fail to develop the additional capacity required of them in emergencies, or even their rated capacity when the coal is poorer than that used in the test. The remedy then usually is the costly one of obtaining additional boilers, and sometimes of building a new boiler-house. The purchaser is fortunate if he can, by a change in the style of furnace or of grates, or by building a taller chimney or by introducing forced draft, so increase the capacity of the boilers as to avoid the necessity of buying additional ones.

The extent of heating surface found by the calculation should also be entered in the specifications as the minimum to be bidden upon. Some bidders may not be able to furnish together with the specified extent of grate-surface as small an extent of heating surface as that called for, since their designs are not adapted for such small ratios of

heating to grate-surface as those given above, but there is no objection to their furnishing as much more as they choose, and among bidders offering the same grate-surface those offering the greater extent of heating surface should have the preference, other conditions being equal. Capacity for emergencies being obtained by extent of grate-surface, economy of coal will be obtained by extent of heating surface above that needed to give an evaporation at the rate of 6 lbs. per sq. ft. of heating surface per hour.

Bidders' Guarantees.—Guarantees of economy and capacity may be inserted in specifications, but they should be considered secondary as compared with dimensions of grate and heating surface, and no attention should be paid to guarantees of unusual economy offered by any bidder who does not give any more heating surface than other bidders, unless that guarantee is based upon the offer of a special furnace or stoker, which may reasonably be expected to give better economy than a plain furnace when soft coal is used.

Type of Boiler.—The calculations made as above described are applicable to any type of boiler. The selection of a type depends on other considerations than capacity or economy, for these depend upon proportions and not on type. These considerations are safety, durability, convenience, or facility for cleaning and making repairs, ground space occupied, ability to furnish dry steam when overdriven, and last of all, cost.

Loss of Fuel Due to Keeping Up Steam-pressure in Idle Boilers.—In a report by F. R. Low to the Committee on Data of the National Electric Light Association (*Electrical World*, June 12, 1897) some statistics were presented showing the amount of coal required to keep up pressure while no steam or water is being taken from the boiler. We quote from the report as follows:

When a boiler is laid off it becomes a drag, the coal used in maintaining the fire in a condition to be started counting for nothing, so far as steam-production is concerned. The engineer of a Philadelphia station on a test found that it required 1200 lbs. of buckwheat coal to keep up a pressure of 125 lbs. on two water-tube boilers, having each 59 sq. ft. of grate-surface. This was 0.424 lbs. per sq. ft. of grate-surface per hour.

A five-days' test of a horizontal tubular boiler showed a consumption of .35 lb. of coal per sq. ft. of grate. Another water-tube boiler in a five-days' test used 0.5 lb. per sq. ft. of grate.

A Lancashire boiler with mechanical stokers used only 0.2 lb. of coal per sq. ft. of grate on a seven-days' test.

Two other water-tube boilers, one on a seven-days' test and the other on a test of several days' duration, used, respectively, 0.7 and 0.5 lb. of coal per sq. ft. of grate.

In each of these cases the boiler was shut off from the main and no steam or water taken from it. The coal was used simply to maintain the pressure. A moderate rate of combustion is 12 lbs. per sq. ft. of grate per hour. Allowing 0.5 as the average consumption while

standing, the coal burned by a boiler in this way would be 4.17 per cent of that burned while running at 12 lbs. per sq. ft. of grate for the same length of time.

If a boiler runs sixteen hours a day at an average rate of 12 lbs. of coal per sq. ft. of grate per hour, and stands the other eight with a consumption of 0.5 lb. per sq. ft. of grate per hour, the coal used, while idle, will be 2.04 per cent of the whole. If it runs half the time, the expense in coal, while standing, will be 4.17 per cent of the total amount. The following table gives the percentages for different lengths of running and different rates of combustion:

| Hours Running. | Hours Standing. | Percentage of Total Coal Used in Idle Boilers at .5 of a Pound per Square Foot of Grate While Idle. | | | | |
|----------------|-----------------|---|------|------|------|------|
| | | Average Rate Combustion per Square Foot Grate While Running. | | | | |
| | | 12 | 15 | 18 | 20 | 24 |
| 23 | 1 | .18 | .15 | .12 | .11 | .10 |
| 22 | 2 | .38 | .30 | .25 | .23 | .19 |
| 21 | 3 | .59 | .47 | .40 | .36 | .28 |
| 20 | 4 | .83 | .66 | .55 | .50 | .41 |
| 19 | 5 | 1.08 | .87 | .66 | .65 | .55 |
| 18 | 6 | 1.37 | 1.10 | .92 | .83 | .69 |
| 17 | 7 | 1.69 | 1.35 | 1.13 | 1.02 | .85 |
| 16 | 8 | 2.04 | 1.63 | 1.37 | 1.23 | 1.03 |
| 15 | 9 | 2.44 | 1.92 | 1.64 | 1.48 | 1.23 |
| 14 | 10 | 2.89 | 2.33 | 1.99 | 1.75 | 1.44 |
| 13 | 11 | 3.40 | 2.73 | 2.30 | 2.07 | 1.70 |
| 12 | 12 | 4.00 | 3.23 | 2.70 | 2.44 | 2.04 |
| 11 | 13 | 4.69 | 3.79 | 3.18 | 2.87 | 2.40 |
| 10 | 14 | 5.51 | 4.46 | 3.75 | 3.38 | 2.83 |
| 9 | 15 | 6.50 | 5.26 | 4.42 | 4.00 | 3.35 |
| 8 | 16 | 7.69 | 6.25 | 5.26 | 4.76 | 3.85 |
| 7 | 17 | 9.19 | 7.41 | 5.96 | 5.79 | 4.87 |
| 6 | 18 | 11.11 | 9.09 | 7.69 | 6.98 | 5.88 |

Coal Used in Banked Fires not a Measure of Loss by Radiation.—

The heating value of the coal, used when the boiler is idle, averaging, according to Mr. Low's report, 4.17 per cent of that used when it is in operation and burning 12 lbs. of coal per sq. ft. per hour, is not to be considered a correct measure of the heat lost by radiation, since when the fire is banked or the draft nearly all shut off, the coal consumed is burned with an insufficient supply of air, and therefore develops less than its full heating value. The gases evolved from the smouldering fire, whether burned or unburned, escape into the chimney at about the temperature of the steam in the boiler. The coal burned while the boiler is idle therefore represents the sum of three different heat losses, viz., that due to imperfect combustion, the heat carried into the chimney, and the heat lost by radiation.

Assuming a ratio of heating to grate-surface of 40 to 1, a rate of driving of 3 lbs. of water per square foot of heating surface per hour and an evaporation of 8 lbs. of water per pound of coal, gives a rate of combustion of 15 lbs. of coal per square foot of grate per hour, a fair figure for water-tube boilers with anthracite coal. Taking the consumption per hour with banked fires as 0.5 lb. per square foot of grate, gives $3\frac{1}{3}$ per cent of the hourly coal consumption when running, a figure which covers all the losses of heat due to banking fires. The loss due to radiation should be considerably less than this figure.

Steam-boiler Economy in Electric-light Stations.*—The difference between the performance of boilers reported for long periods under widely varying capacities, and charged with all the coal used for banking, etc., and their normal efficiency under test conditions, is shown in the following table, where the "test duty" is the best result obtainable under the best conditions with the fuel used; the "actual duty" is the number of pounds of water evaporated in a long term of service, divided by the coal used in the same period. The third column is the ratio of the actual to the test efficiency, showing how badly the efficiency was impaired by the conditions of actual service.

With the exception of No. 11, the apparently low efficiency of which was due to a low grade of Western coal, these results are surprisingly high:

| No. | Test Duty. | Actual Duty. | Ratio Actual to Test. |
|-----|------------|--------------|-----------------------|
| 1 | 8.58 | 8.009 | 94.5 |
| 2 | 8.68 | 7.302 | 84.1 |
| 3 | 9.96 | 8.02 | 80.5 |
| 4 | | 7.5 | |
| 5 | 10.5 | 9.96 | 94.6 |
| 6 | | 10.00 | 95.24 |
| 7 | 7 | 6.14 | 87.71 |
| 8 | | 6.04 | |
| 9 | 11.2 | 9.83 | 87.71 |
| 10 | 10.8 | 9.85 | 97.72 |
| 11 | | 5.75 | |
| 12 | | 11.36 | |
| 13 | | 7.50 | |
| 14 | | 9.00 | |

Where the grate-surface is ample, a very cheap grade of fuel can be used with a considerable reduction of the cost, and it is suggested that an economical advantage may arise from using two grades of fuel in plants that run long hours with widely varying loads; a good steaming coal with which the boilers can be forced at the time of overload, and a cheap small coal which can be used to advantage on the otherwise spare grate-surface when the load is below the average.

* From a Report by F. R. Low to the Committee on Data of the National Electric-light Association. (*Electrical World*, June 12, 1897.)

Cost of Coal per Boiler Horse-power per Year.—Taking a commercial or boiler horse-power as an evaporation equivalent to 34½ lbs. of water from and at 212° per hour, the evaporation per pound of coal under actual conditions of feed-water temperature and steam-pressure at from 5 to 10 lbs., and the cost of coal per ton of 2240 lbs. at from \$1 to \$5, we obtain the following figures for cost of coal per horse-power per year of 3600 hours, or 12 hours per day for 300 days in the year, and per year of 8760 hours, or 24 hours per day for 365 days.

COST OF COAL PER BOILER HORSE-POWER PER YEAR.

| Water Evap. per lb. of Coal. | Coal per Boiler H.P. per hr. | Year of 3600 Hours.. Cost of Coal per Ton. | | | | | Year of 8760 hours. Cost of Coal per Ton. | | | | |
|------------------------------|------------------------------|---|-------|-------|-------|-------|--|-------|-------|--------|--------|
| | | \$1. | \$2. | \$3. | \$4. | \$5. | \$1. | \$2. | \$3. | \$4. | \$5. |
| lbs. 7 | lbs. | \$1. | \$2. | \$3. | \$4. | \$5. | \$1. | \$2. | \$3. | \$4. | \$5. |
| 10 | 3.45 | 5.94 | 11.09 | 16.63 | 22.18 | 27.72 | 13.49 | 26.98 | 40.48 | 53.97 | 67.46 |
| 9 | 3.83 | 6.16 | 12.32 | 18.48 | 24.64 | 30.80 | 14.99 | 29.98 | 44.97 | 59.96 | 74.96 |
| 8 | 4.31 | 6.93 | 13.86 | 20.79 | 27.72 | 34.65 | 16.86 | 33.73 | 50.59 | 67.46 | 84.32 |
| 7 | 4.93 | 7.92 | 15.84 | 23.76 | 31.68 | 39.60 | 19.27 | 38.55 | 57.82 | 77.10 | 96.37 |
| 6 | 5.75 | 9.24 | 18.48 | 27.72 | 36.96 | 46.21 | 22.49 | 44.97 | 67.46 | 89.95 | 112.43 |
| 5 | 6.90 | 11.09 | 22.18 | 33.27 | 44.36 | 55.45 | 26.98 | 53.97 | 80.95 | 107.94 | 134.92 |

Boiler-room Labor.—An investigation made in 1896 for the Steam-users' Association of Boston, Mass., by Mr. R. S. Hale, led to the following conclusions concerning the cost of boiler-room labor:

In plants containing 595 boilers the coal consumption was 8302 tons per week, or 700 tons per boiler per year of 50 weeks. The average cost of boiler-room labor per ton of coal handled was 48 cents, ranging from 26 to 74 cents.

The cost gradually decreases as the size of the plant increases, becoming, however, nearly stationary at 200 tons per week.

The men fire more coal (in the proportion of about 15 per cent) and receive more pay (about 10 per cent) in the plants that run twenty-four hours a day instead of ten hours a day, the result being a cost per ton about 5 per cent less. The difference is not quite so marked when comparing plants burning very large amounts of coal (200 tons a week).

The labor per ton of coal is about 10 per cent less for a steady load than for a variable load of any sort.

Handling coal should cost about 1.6 cents per ton per yard up to five yards, then about 0.1 cent per ton for each additional yard.

Cheap men do as much work as good men, so that the cost of labor is almost always less per ton of coal with cheap men. The quality of the work may not be the same, so that the cost per ton of steam is not necessarily less.

Wages of firemen and work done per man are about the same from Maine to Pennsylvania.

One man (besides night man) can run engine and fire up to about 10 tons per week.

One man (besides engineer and night man) can fire up to about 35 tons per week.

Two men (besides engineer and night man) can fire up to about 55 tons per week.

Three men (besides engineer and night man) can fire up to about 80 tons per week.

These figures assume that the night man does all he can of the banking, cleaning, and starting.

The figures are for average conditions. If the conditions are exceptional, as, for instance, a very long wheel or very variable load, proper allowance should be made.

Mechanical stokers save 30 to 40 per cent of labor in very large plants (over 200 tons per week), 20 to 30 per cent in medium-sized plants (50 to 150 tons per week), and save no labor in small plants.

Handling Coal and Ashes in Large Plants.—Mr. Hale's report gives no data of the cost of handling coal in large modern plants, such as electric-light and power-stations. In the best modern practice the coal received by car or boat is elevated and dumped in large storage-bins under the roof of the boiler-house by means of suitable hoisting and conveying machinery. From the bins it is led down by means of iron pipes and fed by gravity directly into the hoppers of the mechanical stokers. The ashes are dumped from the ash-pits of the several boilers into cars or storage-bins in a tunnel underneath. By such mechanical methods of handling both coal and ashes all shovelling is avoided, and the cost of boiler-room labor per ton of coal may thus be made much less than the lowest figure named in Mr. Hale's report.

Steam-boiler Practice of the Future.—Steam-boiler practice at the present day is in a rather chaotic state. There is a confusing multiplicity of types and of varieties of each type. With any given style of boiler and furnace there is a lack of uniformity in the capacity and economy obtained from boilers of the same size in different places. It is not uncommon to find two or three different styles of boilers in the same boiler-house. In a row of four or five boilers of the same size and style, the arrangement of the flues may differ, so that no two of them have the same draft, and consequently no two of them develop the same power or give the same economy.

Besides the variety in types and in the conditions of running of existing boilers, there is a tendency to change in the conditions. The pressure of steam required by engines is increasing. The small sizes of anthracite are being used instead of the larger sizes, and they require stronger draft, and larger grate-surfaces, and give more trouble

to handle ashes and clinker. Soft coal is in many places displacing anthracite, bringing with it smoky chimneys, and as the smoke nuisance increases new devices are continually being brought forth to suppress it. Real estate in cities is becoming more costly, and boilers are, therefore, designed to economize space, and they are being driven at more rapid rates. Rapid driving with bad water means more trouble from scale, and this enlarges the business of makers of feed-water purifiers, scale-extracting machinery, and "boiler compounds." This is the age of labor-saving, and in order to reduce the labor cost of steam-making automatic stokers and mechanical means of handling coal and ashes are introduced.

The changes above mentioned are now in progress, but the day when stationary steam-boiler practice shall reach a reasonable degree of uniformity, such as has been reached in locomotives and in marine engines and boilers, seems yet far distant. The fittest will survive at last, but the unfit lives a long time.

The following is a list of the leading types and varieties of boilers which still survive in stationary practice in the United States:

Internally Fired.—Galloway, Scotch marine, locomotive, vertical tubular.

Externally Fired.—Shell boilers: cylinder, two-flue, horizontal, and vertical tubular; water-tube boilers: inclined, vertical, and curved tubes; coil or pipe boilers.

Besides these there are numerous combined and nondescript types, and modifications of standard types, which usually have but a short life in the market.

There is no probability that any increased economy of fuel may be obtained by a change from any one type to another, if the conditions of driving remain the same. With any one of these types an efficiency of from 70 to nearly 80 per cent of the theoretically possible may be obtained from good anthracite or semi-bituminous coal, low in ash and moisture, and burned thoroughly in a properly designed furnace, the boiler being driven at its most economical rate, and proper provision being taken to lessen the losses from radiation and from leaks of air through the boiler-setting.

The Survival of a Type will Depend on Some Other Factor than Economy of Fuel.—The possible economy that may be obtained from all types being equal, the standard type or types of the future will be selected for other reasons than economy of fuel. Chief among these reasons are: (1) Safety from explosion. (2) First cost. (3) Durability.

(4) Facility for cleaning. (5) Cost of repairs and facility for making them. (6) Space occupied. (7) Possibility of driving at both low and high rates of evaporation without great loss of fuel economy. (8) Adaptability of the boiler and furnace to different kinds of coal, so that the coal may be changed as market-prices vary.

The seventh reason in this list may require some explanation. It is found in testing boilers at different rates of driving that the fuel-economy bears some relation to the rate of driving, but that the law of this relation varies with the type of boiler, and even in the same boiler when fired with different coal or under different circumstances. In Fig. 134 the upper line *A* shows the maximum economy obtained

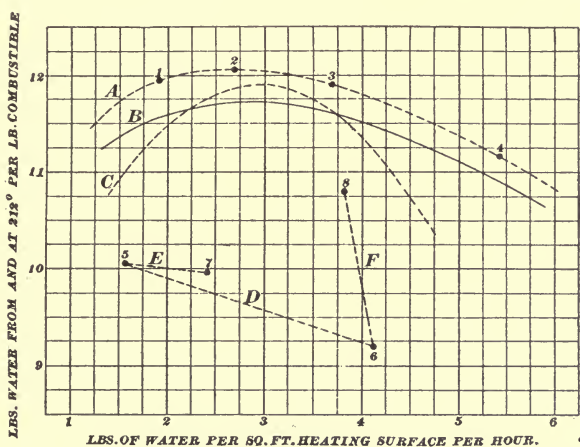

FIG. 134.—RELATION OF ECONOMY TO RATE OF DRIVING.

A, maximum results at the Centennial Exhibition; 1, Firmenich; 2, Root; 3, Smith; 4, Galloway; *B* and *C*, two hypothetical cases; *D*, minimum results at the Centennial Exhibition; *E*, 5, 7, Exeter; *F*, 6, 8, Wiegand.

at different rates of driving in tests of four boilers at the Centennial Exhibition, viz.: The economy of tests of the Firmenich and Root, and the capacity tests of the Smith and Galloway boilers. It is conceivable that there might have been a single boiler which would have given these four results, which would have been an extraordinary, but not impossible record. The line *D* joins the lowest results obtained in the Centennial tests at the rates of driving shown. The results of the other tests, if plotted, would fall inside of the area bounded by the lines *A* and *D*. The relation of rate of driving to economy of the Exeter boiler is shown by the line *E*, and that of the Wiegand boiler by the line *F*. The lines *B* and *C* represent the hypothetical cases of

two boilers tested at a number of different rates. While boiler *C* shows the highest economy, it is only for a limited range of the rate of driving that its economy is greater than that of *B*, the latter showing a higher economy over a wide range, and therefore it may be considered the better boiler, as far as economy of fuel is concerned, for widely varying loads, while *C* is the better for steady driving at a rate which corresponds to that of its maximum economy.

The Boiler Types of the Future.—There is not likely to be any important change in the existing types of boiler used in stationary practice, nor is any new type likely to be developed which will offer any advantages over the present types. New boilers or modifications of old ones will continue to be invented, and some of them, by dint of business enterprise and liberal advertising, may be sold in considerable numbers, but the farther these depart in their construction from the existing types the less likely are they to be permanently successful.

The survival of certain types in the struggle between those now on the market will depend not on economy of fuel, as has already been stated, nor on cheapness of first cost, for as the country increases in wealth, boiler users become more willing to pay fair prices for the best boilers. It will depend chiefly on the factors of durability and facility for cleaning and for repairs. Durability depends largely on the kind of water used in a boiler, and therefore a boiler may survive in New England, where the water is generally of excellent quality, while it may be condemned in many sections of the West, where the water contains large amounts of scale-forming material. The question of economy of space occupied will be an important factor in determining the type of boiler to be used in large plants in cities, where real estate is expensive.

Boiler Furnaces of the Future.—The greatest improvement which is to be made in average boiler practice is the adoption of furnaces for burning soft coal without smoke. In ordinary practice in the Western States an efficiency of 50 per cent or less is not uncommon, with the coal burned in ordinary furnaces. It is quite possible to raise this to 70 or even 75 per cent with automatic stokers, furnaces surrounded by fire-brick, and provision for securing the intimate admixture of very hot air with the distilled gases. The raising of the efficiency of boilers by these means from 50 per cent to 70 per cent would effect a saving of many millions of dollars per year, and it would at the same time abolish the smoke nuisance, which is an increasing one in all large cities.



INDEX.

- Acme stoker, 174
Air, heated, use of in furnaces, 163
 properties of, 18
 required for combustion, 19
 supply, calculation from analysis of
 gases, 32
 supply, effect of varying, 381
 supply, excess formula for, 34
 supply, experiments in varying, 381
Alabama coal-field, 67
Alaska coal-fields, 83
Allen water-tube boiler, 260
Almy water-tube boiler, 264
Alternate method of firing, 161
 of starting and stopping a test, 337,
 369
American underfeed stoker, 177
Analyses of coal, proximate, 352
 of different coals, *see* Coal.
 of gases, 340, 397
 of gases may be erroneous, 437
Analysis, proximate, relation to heating
 value, 103, 108
Anderson water-tube boiler, 404
Andrews boiler, 403
Anthracite, burning small sizes, 148
 in Pennsylvania, 53
 early use of, 54
 results obtained from, 289
Appalachian coal-field, 56
Apparatus for determining heating
 value of coals, 128
 for indicating furnace conditions, 434
Argand steam-blower, 154
Arizona coals, 80
Arkansas coals, 76
Arndt's econometer, 435
Ash, character of, 44

Babcock & Wilcox stoker, 172
 water-tube boiler, 266, 276, 393
Bagasse as fuel, 137
 burner, Cook's, 187
Banking fires, loss due to, 445
Belleville water-tube boiler, 263
Bidders' guarantees, 445

Bids, specifications for, 444
Blechynden's experiments on transmis-
 sion of heat, 235
Block coal, Ohio and Indiana, 68, 69
Blowers, steam- and fan-, tests of, 150
 the Argand, 154
Boiler, Andrews, 403
 Cornish, 248
 double cylinder, 247
 elephant, 248
 Exeter cast-iron, 404
 Galloway, 248
 Harrison cast-iron, 404
 Lancashire, 248
 locomotive, 255
 Lowe tubular, 403
 Manning vertical, 253
 Pierce rotating, 405
 plain cylinder, 188, 200
 plain cylinder, disadvantages of, 200
 practice of the future, 449
 return tubular, 250
 Scotch marine, 255
 Smith tubular, 403
 two-flue, 243
 types, evolution of, 247
 vertical tubular, 251
 Webber vertical, 252
Boiler, water-tube, Allen, 260
 Almy, 264
 Anderson, 404
 Babcock & Wilcox, 266, 276
 Belleville, 263
 Cahall, 271
 Caldwell, 267
 Church, 261
 Dance, 263
 Field, 259
 Firmenich, 265
 Fitch & Voight, 258
 Fletcher, 259
 Gill, 267
 Gurney, 261
 Hazelton, 261
 Joly, 259
 Kelly, 260

- Boiler, water-tube, Kilgore, 263
 Maynard, 265
 Miller, 259
 Morrin's Climax, 274
 Mosher, 276
 National, 267
 Phleger, 262
 Roberts, 264
 Rogers & Black, 262
 Root, 267
 Rowan, 262
 Stevens, 258
 Stirling, 272
 Thornycroft, 275
 Ward, 263
 Wheeler, 265
 Wickes, 272
 Wiegand, 260
 Wilcox, 261
- Boiler-compounds, 319, 322
 Boilers, forms used in different countries, 277
 Bomb calorimeter, Mahler's, 94
 British Thermal Unit, 3
 Briquettes, or pressed fuel, 131
 Brown coal and lignite, 43
 Buckwheat anthracite coal, tests with, 386
 Bunte, tests of German coals, 116
- Cahall water-tube boiler, 271
 Caldwell water-tube boiler, 267
 California coal, 81
 Calorimeter, coal-, Mahler's, 94
 steam-, 338, 353
 correction for, 354
 Calorimetric tests of coals, 87, 126
 Cannel coal, 43
 Capacity, depends on economy, 192
 elementary principles, 188
 of a boiler, 10
 of a plain cylinder boiler, 188, 200
- Carbon, 16
 monoxide due to heavy firing, 31
 monoxide formed from CO_2 , 12
- Centennial Exhibition tests, 290, 402
 Chain-grate stokers, 172
 Chemistry of fuel and combustion, 16
 of scale and scale-solvents, 323
 Chimney-draft theory, 422
 Chimney height for different fuels, 426
 table of sizes of, 428
 Church water-tube boiler, 261
 Circulation of water in boiler, 299
 effect of, on economy, 240
 Classification of coals, 42
 Grüner's, 87
 Climax water-tube boiler, 274
- Coal, analyses of, in various districts, 46, 54 to 83, 85, 87, 93, 104, 112, 114, 117
 Coal, analyses and heating value, 46
 and social progress, 38
 anthracite, in New Mexico, 56
 anthracite, in Pennsylvania, 53
 brown, and lignite, 43
 caking and non-caking, 43
 calorimetric tests, 87, 93
 cannel, 43
 classification of, 42, 87
 effect of weathering, 116
 formation of, 39
 graphitic, in Rhode Island, 52
 heating value of, 44
 hygrometric properties of, 36
 moisture in, 41
 production of, in U. S., 39, 40
 quality of, in relation to boiler capacity, 50
 sampling of, 339
 selection of, for steam-boilers, 119
 semi-anthracite, 54
 soft, how to burn, 155
 testing relative values of, 121
 valuing by test and analysis, 51
- Coal-dust as fuel, 132, 183
 burning, Wegener system, 183
 De Camp system, 182
- Coal-fields of the United States, 52
 bituminous and semi-bituminous, 56
- Coals, tests of heating value by Bunte, 116
 Hale & Williams, 113
 Johnson, 84
 Lord & Haas, 101
 Mahler, 92
 Scheurer-Kestner, 84
 Slosson & Colburn, 112
- Code of rules for boiler-trials, 333
 Coefficient of performance, "a," 220
 Coke, 131
 Coking system of firing, 159
 Colorado coals, 78
 Combustible, definition of, 12
 Combustion, chemistry of, 16
 heat produced by, 20
 heat of, 7
 of fuel, 8
 imperfect, 8
 rate of, due to height of chimney, 425
 complete, how to secure, 159
- Commercial and experimental results, 361
 Complaints concerning boilers, 301
 Connellsville coal, 46
 Corn as fuel, 144
 Cornish boiler, 248
 Corrosion, internal, 313
 external, 328
 Cost of coal per boiler horse-power, 448
 of labor in boiler-rooms, 448
 of handling coal and ashes, 449

- Coxe automatic stoker, 170
 Culm, anthracite, tests with, 386
 Cumberland, Md., coal, 46
 coal-field, 62

 Dance water-tube boiler, 262
 DeCamp powdered-coal system, 182
 Decomposition, heat absorbed by, 21
 Defects causing explosions, 329
 discovered by inspection, 329
 Definitions and principles, 1
 Designing boilers for a railway plant,
 437
 Distribution of the heating value of
 fuel, 360
 Down-draft furnace, 165
 Draft, due to height of chimney, 424
 forced, 179
 force or intensity of, 423
 gauge, 362
 induced, 180
 poor, 302
 Dulong's formula for heating value, 7,
 93, 103
 Durability, 296, 328
 Durston's experiments on transmission
 of heat, 239
 Dust-fuel, 132, 183

 Econometer, Arndt's, 435
 Economizers, 430
 saving effected by, 432
 Economy, calculation of, 191
 depends on rate of driving, 196
 elementary principles of, 188
 of boilers in electric stations, 447
 of fuel does not depend on type, 293
 range of found in practice, 380
 Efficiency, calculation of, 341
 does not depend upon type of boiler,
 242
 effect of various conditions on, 221
 general formula for, 219
 of a boiler, 11
 of boiler and grate, 359
 of the heating surface, 14, 205
 Electric-light stations, boilers in, 447
 Elephant boiler, 248
 Ellis & Eaves hot-air system, 182
 Equivalent evaporation, 11
 Evaporation, factors of, 416
 tests, 332
 Exeter cast-iron boiler, 404
 Experiments, see Tests.
 Explosion, danger of, 295
 Explosions caused by hidden defects,
 329

 Factors of evaporation, 416
 Feed-water, quality of, 313
 Field water-tube boiler, 259

 Firing, improper, 307
 mechanical, 166
 methods, with anthracite, 147
 with soft coal, 155
 Firmenich water-tube boiler, 265
 Fitch & Voight's water-tube boiler, 258
 Flame, 9
 Fletcher water-tube boiler, 259
 Flue-gas analysis, 366
 Forced draft, 179
 Fuel and combustion, 16
 Fuels other than coal, 131
 mixed, heating value of, 21
 Furnace not adapted to coal, 304
 Furnaces for anthracite coal, 147
 for bituminous coal, 155
 for burning tan-bark, 136, 187
 Hawley down-draft, 165
 Kent's wing-wall, 161
 location of, 145
 requirements of, 146
 use of heated air in, 163
 Walker, 160
 Future boiler and furnace practice, 449

 Galloway boiler, 248
 Gas analyses and the heat balance, 436
 Gases, weight and densities of, 20
 weight of, calculated, 32
 Gas-fuel, 142
 Georgia coals, 67
 German coals, Bunte's tests, 116
 Gill water-tube boiler, 267
 Graphic record of a test, 372
 Graphitic coal, in Rhode Island, 52
 Grate and heating surface required for
 given power, 282, 285
 bars, air-space through, 288
 bars, 151
 the McClave, 153
 Grates, shaking and dumping, 153
 Grate-surface, calculations of, 440
 large ratios of, 443
 insufficient, 304
 Grooving or channelling, 317
 Guarantees in bids, 445
 Gurney water-tube boiler, 261

 Harrison cast-iron boiler, 404
 Hawley down-draft furnace, 165
 Hazelton water-tube boiler, 261
 Heat, 2
 absorbed by decomposition, 21
 balance, 341, 360, 436
 latent, 4
 of combustion, 7
 quantity of, 6
 specific, 4
 transfer of, 10
 transmission through plates, 235, 239
 unit, definition of, 3

- Heated air, use of in furnace, 163, 181,
 Heating surface, calculations of, 440
 efficiency of, 205
 insufficient, 195, 311
 measurement of, 284
 required for given power, 283
 Heating value of coals, 84, 128
 available, of hydrogen, 22
 of hydrogenous fuels, 24
 relation to fixed carbon, 108, 110
 Heating values of pure fuels, 20
 of compound fuels, 21
 of various substances, 20
 Horse-power of a steam-boiler, 11, 280
 builder's rating, 285
 Hot-air system, Howden, 181
 Ellis & Eaves, 182
 Howden's hot-air system, 181
 Humidity, relative, 18
 Hydrogen, 16
 available heating value of, 22
 Hygrometric properties of coals, 36
- Illinois coal-basin, 69
 coals, 70
 Indiana coals, 69
 Incrustation and scale, 317
 Indian Territory coals, 77
 Inspection, facility for, 298
 Iowa coals, 74
- Johnson's tests of American coals, 84
 Joly water-tube boiler, 259
 Jones under-feed stoker, 179
- Kelly water-tube boiler, 260
 Kent's wing-wall furnace, 161
 Kentucky, eastern, coal-field, 65
 western, coal-field, 69
 Kilgore water-tube boiler, 263
- Lancashire boiler, 248
 Latent heat, 4
 of steam, 408
 Leakage of air through brickwork, 306
 Life of a steam-boiler, 328
 Lignite, 43
 Liquid fuel, see Petroleum, 137
 advantages of, 141
 Lord and Haas's tests of American coals,
 101
 Loss of fuel due to banking fires, 445
 Lowe horizontal tubular boiler, 403
- Mahler's coal calorimeter, 94
 tests of European coals, 92
 Manning vertical boiler, 253
 Marine boilers, 255, 275, 276
 Maryland semi-bituminous coal, 46, 62
 Maynard water-tube boiler, 265
- Measures for comparing duty, 282
 Megass, see Bagasse, 137
 Michigan or northern coal-field, 68
 Miller water-tube boiler, 259
 Missouri coal-basin, 74
 Moisture in coal, method of finding, 339,
 351
 in steam, 353
 in steam, determination of, 374
 Montana coals, 81
 Morrin water-tube boiler, 274
 Mosher boiler, 276
 Murphy automatic furnace, 176
- National water-tube boiler, 267
 Nevada coal, 81
 New Mexico, anthracite in, 56
 coals of, 80
 New River, W. Va., coal, 46
 Nitrogen, 17
 North Carolina coal, 64
 North Dakota coal, 81
- Ohio coals, 67, 105
 Oil, methods of burning, 184
 Oil, petroleum as fuel, 137
 versus coal, 141
 Operation of a steam-boiler, 12
 Oregon coals, 82
 Orsat apparatus for analyzing gases, 366
 Oxygen, 17
 required for combustion, 19
- Peat or turf, 133
 Pennsylvania anthracite, 46, 54
 bituminous coals, 46, 59
 Performance of boilers, 289
 Petroleum as fuel, 137
 methods of burning, 184
 Phleger water-tube boiler, 262
 Pierce rotating boiler, 405
 Pittsburg coal, 46, 104
 Playfor's stoker, 172
 Pocahontas coal-field, 63
 coal, 104
 Points of a good boiler, 292
 Powdered fuel, 132, 183
 Practical conclusions derived from
 theory, 228
 Precautions in boiler-testing, 349
 Pressed fuel, or briquettes, 131
 Principles and definitions, 1
 Producer-gas, 143
 Proportions of grate and heating sur-
 face, 282
 of flues and gas-passages, 288
 Pyrometers, 435
- Quality of steam, corrections for, 355
 superheated steam, 358
 Quantity of heat in a body, 6

- Radiation, effect of, on efficiency, 210
 method of measuring, 373
 loss due to, 446
- Railway plant, designing boilers for, 437
- Rating of boilers, 11
- Repairs of boilers, 297
- Report of a boiler-trial, forms for, 342
- Retarders, 181
- Rhode Island, graphitic coal in, 52
- Ringelmann's smoke-chart, 364
- Roberts water-tube boiler, 264
- Rogers & Black water-tube boiler, 262
- Roney mechanical stoker, 173
- Root water-tube boiler, 267
- Rowan water-tube boiler, 262
- Rules for conducting boiler-trials, 333
- Sampling flue-gases, 365
- Sampling of coal, 339
- Sawdust as fuel, 135
- Scale and incrustation, 317
 causes of, 321
- Scheurer-Kestner's tests of European
 coals, 84
- Scotch marine boiler, 255
- Selection of coal for steam-boilers, 116
- Selecting a new type of boiler, 292
- Semi-bituminous coal-fields, 56
 coal, analyses, 46, 59
- Setting of boiler, bad, 305
- Smith boiler, 403
- Smoke, how it may be burned, 8
 how to avoid, 156
 measurements, 364
 observations, 341
 preventing furnace, requirements of,
 158
 prevention, success of, 157
- Smoke-chart, Ringelmann's, 364
- Smoky chimneys not necessary, 156
- Specifications for bidders, 444
- Specific heat, 4
 heat of flue-gases, 228
- Spence's experiments in varying the air-
 supply, 381
- Standard method of starting a test, 336
- Starting and stopping a test, 336, 369
- Steam- and fan-blowers, tests with, 150
 calorimeter, use of, 338
 dry, identification of, 410
 dryness of, 299
 jets for preventing smoke, 164
 properties of, 408
 quality of, correction for, 355
 table, 410
 use of under-grates, 148
- Stevens water-tube boiler, 258
- Stirling water-tube boiler, 272
- Stokers, mechanical or automatic, 166
 Acme, 174
 American, 177
- Stokers, Babcock & Wilcox, 172
 Coxe, 170
 Jones under-feed, 179
 Murphy, 177
 Playford, 172
 Roney, 173
 Vicars, 169
 Wilkinson, 176
- Straw as fuel, 136
- Sulphur, 17
 heating value of, 35
 heating value of, in coal, 35
- Superheated steam, quality of, 358
- Superheating, how determined, 338
- Tan-bark as fuel, 136
- Temperature, 2
 due to burning carbon, 26
 " " " hydrogen, 24 and 27
 of the fire, 25
 theoretical, 26
- Tennessee coals, 66
- Test, graphic record of a, 372
- Testing relative value of coals, 121
- Tests, computation of results, 376
 evaporation, object of, 332, 348
 of a Babcock & Wilcox marine boiler,
 393
 of a Thornycroft boiler, 398
 of Stirling boilers with anthracite
 coal, 386
 of two-flue boilers with Pittsburg
 coal, 392
 rules for, 333
 with anthracite at the Centennial Ex-
 hibition, 290, 402
 with small sizes of anthracite coal,
 383
- Texas coals, 78
- Thornycroft marine water-tube boiler,
 275, 398
- Transfer of heat, 10
- Transmission of heat through plates,
 235, 239
- Trials, see Tests.
- Troubles and complaints, 301
- Turf or peat, 133
- Under-feed stokers, 177, 179
 Unit of evaporation, 4
- Urquhart oil-burner, 187
- Utah coals, 80
- Valuing coals by test and by analysis,
 51
- Vicars automatic stoker, 169
- Virginia anthracite, 55
 coal-fields, 63
- Ward coil-pipe boiler, 263
- Washington coal, 82

- Waste heat, method of saving, 202
Water, properties of, 406
 and steam-capacity, 298
 level, steadiness of, 299
Water, quality of feed-, 313
Water-tube boilers, 258
 using waste gases of a plain cylinder
 boiler, 202
Weathering of coal, 116
Webber vertical boiler, 251
Wegener powdered-coal system, 183
West Virginia coals, 64, 104
Wet tan-bark, furnaces for, 136, 187
Wheeler water-tube boiler, 265
Wickes water-tube boiler, 272
Wiegand water-tube boiler, 260
Wilcox water-tube boiler, 261
Wilkinson stoker, 176
Wood, analysis of, 41
 as fuel, 134
 heating value of, 135
Wyoming coal, 80
Youghiogeny coal, 46
Zinc, use of to prevent corrosion, 316

SHORT-TITLE CATALOGUE

OF THE

PUBLICATIONS

OF

JOHN WILEY & SONS,

NEW YORK.

LONDON: CHAPMAN & HALL, LIMITED.

ARRANGED UNDER SUBJECTS.

Descriptive circulars sent on application.

Books marked with an asterisk are sold at *net* prices only.

All books are bound in cloth unless otherwise stated.

AGRICULTURE.

| | | |
|---|-------|--------|
| Armsby's Manual of Cattle Feeding..... | 12mo, | \$1 75 |
| Budd and Hansen, American Horticulture Manual. (<i>In press.</i>) | | |
| Downing's Fruit and Fruit Trees..... | .8vo, | 5 00 |
| Grotenfelt's The Principles of Modern Dairy Practice. (Woll.) | | |
| | 12mo, | 2 00 |
| Kemp's Landscape Gardening..... | 12mo, | 2 50 |
| Maynard's Landscape Gardening..... | 12mo, | 1 50 |
| Steel's Treatise on the Diseases of the Dog..... | .8vo, | 3 50 |
| Stockbridge's Rocks and Soils..... | .8vo, | 2 50 |
| Woll's Handbook for Farmers and Dairy-men..... | 12mo, | 1 50 |

ARCHITECTURE.

| | | |
|---|-------|------|
| Berg's Buildings and Structures of American Railroads..... | 4to, | 5 00 |
| Birkmire's American Theatres—Planning and Construction..... | .8vo, | 3 00 |
| “ Architectural Iron and Steel..... | .8vo, | 3 50 |
| “ Compound Riveted Girders..... | .8vo, | 2 00 |
| “ Skeleton Construction in Buildings..... | .8vo, | 3 00 |
| “ Planning and Construction of High Office Buildings. | | |
| | .8vo, | 3 50 |
| Briggs' Modern Am. School Building..... | .8vo, | 4 00 |
| Carpenter's Heating and Ventilating of Buildings..... | .8vo, | 3 00 |

| | | |
|--|----------------|--------|
| Freitag's Architectural Engineering. | 8vo, | \$2 50 |
| " The Fireproofing of Steel Buildings | 8vo, | 2 50 |
| Gerhard's Sanitary House Inspection. | 16mo, | 1 00 |
| " Theatre Fires and Panics. | 12mo, | 1 50 |
| Hatfield's American House Carpenter. | 8vo, | 5 00 |
| Holly's Carpenter and Joiner. | 18mo, | 75 |
| Kidder's Architect and Builder's Pocket-book. | 16mo, morocco, | 4 00 |
| Merrill's Stones for Building and Decoration. | 8vo, | 5 00 |
| Monckton's Stair Building—Wood, Iron, and Stone. | 4to, | 4 00 |
| Wait's Engineering and Architectural Jurisprudence. | 8vo, | 6 00 |
| | Sheep, | 6 50 |
| " Law of Operations Preliminary to Construction in En- gineering and Architecture. | 8vo, | 5 00 |
| | Sheep, | 5 50 |
| Worcester's Small Hospitals—Establishment and Maintenance, including Atkinson's Suggestions for Hospital Archi- tecture. | 12mo, | 1 25 |
| * World's Columbian Exposition of 1893. | Large 4to, | 1 00 |

ARMY, NAVY, Etc.

| | | |
|--|--------------------------|-------|
| * Bruff's Ordnance and Gunnery. | 8vo, | 6 00 |
| Chase's Screw Propellers. | 8vo, | 3 00 |
| Cronkhite's Gunnery for Non-com. Officers. | 32mo, morocco, | 2 00 |
| * Davis's Treatise on Military Law. | 8vo, | 7 00 |
| | Sheep, | 7 50 |
| * " Elements of Law. | 8vo, | 2 50 |
| De Brack's Cavalry Outpost Duties. (Carr.). | 32mo, morocco, | 2 00 |
| Dietz's Soldier's First Aid. | 16mo, morocco, | 1 25 |
| * Dredge's Modern French Artillery. | Large 4to, half morocco, | 15 00 |
| * " Record of the Transportation Exhibits Building, World's Columbian Exposition of 1893. | 4to, half morocco, | 5 00 |
| Durand's Resistance and Propulsion of Ships. | 8vo, | 5 00 |
| * Fieberger's Field Fortification, including Military Bridges, Demolitions, Encampments and Communications. | Large 12mo, | 2 00 |
| * Dyer's Light Artillery. | 12mo, | 3 00 |
| * Hof's Naval Tactics. | 8vo, | 1 50 |
| * Ingalls's Ballistic Tables. | 8vo, | 1 50 |

| | | |
|--|--------------------|--------|
| Ingalls's Handbook of Problems in Direct Fire..... | 8vo, | \$4 00 |
| Mahan's Permanent Fortifications. (Mercur.)..... | 8vo, half morocco, | 7 50 |
| * Mercur's Attack of Fortified Places..... | 12mo, | 2 00 |
| * " Elements of the Art of War..... | 8vo, | 4 00 |
| Metcalf's Ordnance and Gunnery..... | 12mo, with Atlas, | 5 00 |
| Murray's A Manual for Courts-Martial..... | 16mo, morocco, | 1 50 |
| " Infantry Drill Regulations adapted to the Springfield Rifle, Caliber .45..... | 32mo, paper, | 10 |
| * Phelps's Practical Marine Surveying..... | 8vo, | 2 50 |
| Powell's Army Officer's Examiner..... | 12mo, | 4 00 |
| Sharpe's Subsisting Armies..... | 32mo, morocco, | 1 50 |
| Wheeler's Siege Operations..... | 8vo, | 2 00 |
| Winthrop's Abridgment of Military Law..... | 12mo, | 2 50 |
| Woodhull's Notes on Military Hygiene..... | 16mo, | 1 50 |
| Young's Simple Elements of Navigation..... | 16mo, morocco, | 2 00 |
| " " " " " first edition..... | | 1 00 |

ASSAYING.

| | | |
|--|----------------|------|
| Fletcher's Quant. Assaying with the Blowpipe.. | 16mo, morocco, | 1 50 |
| Furman's Practical Assaying..... | 8vo, | 3 00 |
| Kunhardt's Ore Dressing..... | 8vo, | 1 50 |
| Miller's Manual of Assaying..... | 12mo, | 1 00 |
| O'Driscoll's Treatment of Gold Ores..... | 8vo, | 2 00 |
| Ricketts and Miller's Notes on Assaying..... | 8vo, | 3 00 |
| Thurston's Alloys, Brasses, and Bronzes..... | 8vo, | 2 50 |
| Wilson's Cyanide Processes..... | 12mo, | 1 50 |
| " The Chlorination Process..... | 12mo, | 1 50 |

ASTRONOMY.

| | | |
|--|-------|------|
| Craig's Azimuth..... | 4to, | 3 50 |
| Doolittle's Practical Astronomy..... | 8vo, | 4 00 |
| Gore's Elements of Geodesy..... | 8vo, | 2 50 |
| Hayford's Text-book of Geodetic Astronomy..... | 8vo, | 3 00 |
| * Michie and Harlow's Practical Astronomy..... | 8vo, | 3 00 |
| * White's Theoretical and Descriptive Astronomy..... | 12mo, | 2 00 |

BOTANY.

| | | |
|---|------------|------|
| Baldwin's Orchids of New England..... | Small 8vo, | 1 50 |
| Thomé's Structural Botany..... | 16mo, | 2 25 |
| Westermaier's General Botany. (Schneider.)..... | 8vo, | 2 00 |

BRIDGES, ROOFS, Etc.

(See also ENGINEERING, p. 7.)

| | | |
|---|----------------|--------|
| Boller's Highway Bridges..... | 8vo, | \$2 00 |
| * " The Thames River Bridge..... | 4to, paper, | 5 00 |
| Burr's Stresses in Bridges.... |8vo, | 3 50 |
| Crehore's Mechanics of the Girder..... |8vo, | 5 00 |
| Du Bois's Stresses in Framed Structures..... | Small 4to, | 10 00 |
| Foster's Wooden Trestle Bridges |4to, | 5 00 |
| Greene's Arches in Wood, etc..... |8vo, | 2 50 |
| " Bridge Trusses..... |8vo, | 2 50 |
| " Roof Trusses..... |8vo, | 1 25 |
| Howe's Treatise on Arches |8vo, | 4 00 |
| Johnson's Modern Framed Structures..... | Small 4to, | 10 00 |
| Merriman & Jacoby's Text-book of Roofs and Bridges. | | |
| Part I., Stresses..... |8vo, | 2 50 |
| Merriman & Jacoby's Text-book of Roofs and Bridges. | | |
| Part II., Graphic Statics..... |8vo, | 2 50 |
| Merriman & Jacoby's Text-book of Roofs and Bridges. | | |
| Part III., Bridge Design..... |8vo, | 2 50 |
| Merriman & Jacoby's Text-book of Roofs and Bridges. | | |
| Part IV., Continuous, Draw, Cantilever, Suspension, and | | |
| Arched Bridges..... |8vo, | 2 50 |
| * Morison's The Memphis Bridge..... | Oblong 4to, | 10 00 |
| Waddell's De Pontibus (a Pocket-book for Bridge Engineers). | | |
| | 16mo, morocco, | 3 00 |
| " Specifications for Steel Bridges..... |12mo, | 1 25 |
| Wood's Construction of Bridges and Roofs..... |8vo, | 2 00 |
| Wright's Designing of Draw Spans. Parts I. and II.. | 8vo, each | 2 50 |
| " " " " " Complete..... |8vo, | 3 50 |

CHEMISTRY—BIOLOGY—PHARMACY—SANITARY SCIENCE.

| | | |
|---|-----------------|------|
| Adriance's Laboratory Calculations..... |12mo, | 1 25 |
| Allen's Tables for Iron Analysis..... |8vo, | 3 00 |
| Austen's Notes for Chemical Students..... |12mo, | 1 50 |
| Bolton's Student's Guide in Quantitative Analysis..... |8vo, | 1 50 |
| Boltwood's Elementary Electro Chemistry..... | (In the press.) | |
| Classen's Analysis by Electrolysis. (Herrick and Boltwood.) | 8vo, | 3 00 |

| | | |
|--|----------------------|--------|
| Cohn's Indicators and Test-papers..... | 12mo | \$2 00 |
| Crafts's Qualitative Analysis. (Schaeffer.)..... | 12mo, | 1 50 |
| Davenport's Statistical Methods with Special Reference to Biological Variations..... | 12mo, morocco, | 1 25 |
| Drechsel's Chemical Reactions. (Merrill.)..... | 12mo, | 1 25 |
| Erdmann's Introduction to Chemical Preparations. (Dunlap.)..... | 12mo, | 1 25 |
| Fresenius's Quantitative Chemical Analysis. (Allen.)..... | 8vo, | 6 00 |
| " Qualitative " " (Johnson.)..... | 8vo, | 3 00 |
| " " " " (Wells.) Trans. | | |
| 16th German Edition..... | 8vo, | 5 00 |
| Fuertes's Water and Public Health..... | 12mo, | 1 50 |
| " Water Filtration Works..... | (<i>In press.</i>) | |
| Gill's Gas and Fuel Analysis..... | 12mo, | 1 25 |
| Goodrich's Economic Disposal of Towns' Refuse.... | (<i>In press.</i>) | |
| Hammarsten's Physiological Chemistry. (Mandel.)..... | 8vo, | 4 00 |
| Helm's Principles of Mathematical Chemistry. (Morgan). | 12mo, | 1 50 |
| Hopkins' Oil-Chemist's Hand-book..... | 8vo, | 3 00 |
| Ladd's Quantitative Chemical Analysis..... | 12mo, | 1 00 |
| Landauer's Spectrum Analysis. (Tingle.)..... | 8vo, | 3 00 |
| Löb's Electrolysis and Electro-synthesis of Organic Compounds. (Lorenz.)..... | 12mo, | 1 00 |
| Mandel's Bio-chemical Laboratory..... | 12mo, | 1 50 |
| Mason's Water-supply..... | 8vo, | 5 00 |
| " Examination of Water..... | 12mo, | 1 25 |
| Meyer's Radicles in Carbon Compounds. (Tingle.)..... | 12mo, | 1 00 |
| Mixer's Elementary Text-book of Chemistry..... | 12mo, | 1 50 |
| Morgan's The Theory of Solutions and its Results..... | 12mo, | 1 00 |
| " Elements of Physical Chemistry..... | 12mo, | 2 00 |
| Nichols's Water-supply (Chemical and Sanitary)..... | 8vo, | 2 50 |
| O'Brine's Laboratory Guide to Chemical Analysis..... | 8vo, | 2 00 |
| Pinner's Organic Chemistry. (Austen.)..... | 12mo, | 1 50 |
| Poole's Calorific Power of Fuels..... | 8vo, | 3 00 |
| Richards's Cost of Living as Modified by Sanitary Science. | 12mo. | 1 00 |
| " and Woodman's Air, Water, and Food..... | 8vo, | 2 00 |
| Ricketts and Russell's Notes on Inorganic Chemistry (Non-metallic)..... | Oblong 8vo, morocco, | 75 |
| Rideal's Sewage and the Bacterial Purification of Sewage.. | 8vo, | 3 50 |
| Ruddiman's Incompatibilities in Prescriptions..... | 8vo, | 2 00 |
| Schimpf's Volumetric Analysis..... | 12mo, | 2 50 |
| Spencer's Sugar Manufacturer's Handbook.... | 16mo, morocco, | 2 00 |
| " Handbook for Chemists of Beet Sugar Houses. | 16mo, morocco, | 3 00 |
| Stockbridge's Rocks and Soils..... | 8vo, | 2 50 |
| *Tillman's Descriptive General Chemistry..... | 8vo, | 3 00 |

| | | |
|--|------------|--------|
| Van Deventer's Physical Chemistry for Beginners. (Boltwood.) | 12mo, | \$1 50 |
| Wells's Inorganic Qualitative Analysis..... | 12mo, | 1 50 |
| " Laboratory Guide in Qualitative Chemical Analysis. | 8vo, | 1 50 |
| Whipple's Microscopy of Drinking-water..... | 8vo, | 3 50 |
| Wiechmann's Chemical Lecture Notes..... | 12mo, | 3 00 |
| " Sugar Analysis..... | Small 8vo, | 2 50 |
| Wulling's Inorganic Phar. and Med. Chemistry..... | 12mo, | 2 00 |

DRAWING.

| | | |
|--|---------------|------|
| Hill's Shades and Shadows and Perspective..... | 8vo, | 2 00 |
| MacCord's Descriptive Geometry..... | 8vo, | 3 00 |
| " Kinematics..... | 8vo, | 5 00 |
| " Mechanical Drawing..... | 8vo, | 4 00 |
| Mahan's Industrial Drawing. (Thompson.)..... | 2 vols., 8vo, | 3 50 |
| Reed's Topographical Drawing. (H. A.)..... | 4to, | 5 00 |
| Reid's A Course in Mechanical Drawing..... | 8vo. | 2 00 |
| " Mechanical Drawing and Elementary Machine Design. | 8vo, | 3 00 |
| Smith's Topographical Drawing. (Macmillan.)..... | 8vo, | 2 50 |
| Warren's Descriptive Geometry..... | 2 vols., 8vo, | 3 50 |
| " Drafting Instruments..... | 12mo, | 1 25 |
| " Free-hand Drawing..... | 12mo, | 1 00 |
| " Linear Perspective..... | 12mo, | 1 00 |
| " Machine Construction..... | 2 vols., 8vo, | 7 50 |
| " Plane Problems..... | 12mo, | 1 25 |
| " Primary Geometry..... | 12mo, | 75 |
| " Problems and Theorems..... | 8vo, | 2 50 |
| " Projection Drawing..... | 12mo, | 1 50 |
| " Shades and Shadows..... | 8vo. | 3 00 |
| " Stereotomy—Stone-cutting..... | 8vo, | 2 50 |
| Whelpley's Letter Engraving..... | 12mo, | 2 00 |
| Wilson's Free-hand Perspective..... | 8vo, | 2 50 |

ELECTRICITY, MAGNETISM, AND PHYSICS.

| | | |
|---|-------|------|
| Anthony and Brackett's Text-book of Physics. (Magic.) Small | 8vo, | 3 00 |
| Anthony's Theory of Electrical Measurements..... | 12mo, | 1 00 |
| Barker's Deep-sea Soundings..... | 8vo, | 2 00 |
| Benjamin's Voltaic Cell..... | 8vo, | 3 00 |
| " History of Electricity..... | 8vo, | 3 00 |

| | | |
|---|----------------------|--------|
| Church's Notes and Examples in Mechanics | 8vo, | \$2 00 |
| Crandall's Earthwork Tables..... | 8vo, | 1 50 |
| " The Transition Curve..... | 16mo, morocco, | 1 50 |
| Davis's Elevation and Stadia Tables | Small 8vo, | 1 00 |
| Dredge's Penn. Railroad Construction, etc. Large 4to, | | |
| half morocco, \$10; paper, | | 5 00 |
| * Drinker's Tunnelling | 4to, half morocco, | 25 00 |
| Eissler's Explosives—Nitroglycerine and Dynamite..... | 8vo, | 4 00 |
| Frizell's Water Power..... | 8vo, | 5 00 |
| Folwell's Sewerage..... | 8vo, | 3 00 |
| " Water-supply Engineering..... | 8vo, | 4 00 |
| Fowler's Cofferdam Process for Piers..... | 8vo, | 2 50 |
| Fuertes's Water Filtration Works..... | (<i>In press.</i>) | |
| Gerhard's Sanitary House Inspection..... | 12mo, | 1 00 |
| Godwin's Railroad Engineer's Field-book..... | 16mo, morocco, | 2 50 |
| Goodrich's Economic Disposal of Towns' Refuse..... | (<i>In press.</i>) | |
| Gore's Elements of Geodesy..... | 8vo, | 2 50 |
| Hazlehurst's Towers and Tanks for Cities and Towns..... | (<i>In press.</i>) | |
| Howard's Transition Curve Field-book..... | 16mo, morocco, | 1 50 |
| Howe's Retaining Walls (New Edition)..... | 12mo, | 1 25 |
| Hudson's Excavation Tables. Vol. II..... | 8vo, | 1 00 |
| Hutton's Mechanical Engineering of Power Plants..... | 8vo, | 5 00 |
| " Heat and Heat Engines..... | 8vo, | 5 00 |
| Johnson's Materials of Construction | 8vo, | 6 00 |
| " Theory and Practice of Surveying..... | Small 8vo, | 4 00 |
| Kent's Mechanical Engineer's Pocket-book..... | 16mo, morocco, | 5 00 |
| Kiersted's Sewage Disposal..... | 12mo, | 1 25 |
| Mahan's Civil Engineering. (Wood.)..... | 8vo, | 5 00 |
| Merriman and Brook's Handbook for Surveyors... .. | 16mo, mor., | 2 00 |
| Merriman's Precise Surveying and Geodesy..... | 8vo, | 2 50 |
| " Sanitary Engineering..... | 8vo, | 2 00 |
| Nagle's Manual for Railroad Engineers..... | 16mo, morocco, | 3 00 |
| Ogden's Sewer Design..... | 12mo, | 2 00 |
| Patton's Civil Engineering..... | 8vo, half morocco, | 7 50 |
| " Foundations..... | 8vo, | 5 00 |
| Philbrick's Field Manual for Engineers..... | 16mo, morocco, | 3 00 |
| Pratt and Alden's Street-railway Road-beds..... | 8vo, | 2 00 |
| Rockwell's Roads and Pavements in France..... | 12mo, | 1 25 |
| Schuyler's Reservoirs for Irrigation | Large 8vo, | 5 00 |
| Searles's Field Engineering | 16mo, morocco, | 3 00 |
| " Railroad Spiral..... | 16mo, morocco, | 1 50 |
| Siebert and Biggin's Modern Stone Cutting and Masonry... .. | 8vo, | 1 50 |
| Smart's Engineering Laboratory Practice..... | 12mo, | 2 50 |
| Smith's Wire Manufacture and Uses..... | Small 4to, | 3 00 |
| Spalding's Roads and Pavements..... | 12mo, | 2 00 |

| | | |
|---|----------------|--------|
| Spalding's Hydraulic Cement | 12mo, | \$2 00 |
| Taylor's Prismoidal Formulas and Earthwork. | .8vo, | 1 50 |
| Thurston's Materials of Construction | .8vo, | 5 00 |
| Tillson's Street Pavements and Paving Materials | .8vo, | 4 00 |
| * Trautwine's Civil Engineer's Pocket-book. | 16mo, morocco, | 5 00 |
| * " Cross-section. | Sheet, | 25 |
| * " Excavations and Embankments. | .8vo, | 2 00 |
| * " Laying Out Curves. | 12mo, morocco, | 2 50 |
| Turneure and Russell's Public Water-supplies. | .8vo, | 5 00 |
| Waddell's De Pontibus (A Pocket-book for Bridge Engineers). | 16mo, morocco, | 3 00 |
| Wait's Engineering and Architectural Jurisprudence. | .8vo, | 6 00 |
| | Sheep, | 6 50 |
| " Law of Field Operation in Engineering, etc. | .8vo, | 5 00 |
| | Sheep, | 5 50 |
| Warren's Stereotomy—Stone-cutting. | .8vo, | 2 50 |
| Webb's Engineering Instruments. New Edition. 16mo, morocco, | | 1 25 |
| " Railroad Construction. | .8vo, | 4 00 |
| Wegmann's Construction of Masonry Dams. | .4to, | 5 00 |
| Wellington's Location of Railways. | Small 8vo, | 5 00 |
| Wheeler's Civil Engineering. | .8vo, | 4 00 |
| Wilson's Topographical Surveying. | .8vo, | 3 50 |
| Wolf's Windmill as a Prime Mover. | .8vo, | 3 00 |

HYDRAULICS.

(See also ENGINEERING, p. 7.)

| | | |
|---|-------------|------|
| Bazin's Experiments upon the Contraction of the Liquid Vein. (Trautwine.) | .8vo, | 2 00 |
| Bovey's Treatise on Hydraulics. | .8vo, | 4 00 |
| Church's Mechanics of Engineering, Solids, and Fluids. | .8vo, | 6 00 |
| Coffin's Graphical Solution of Hydraulic Problems. | 12mo, | 2 50 |
| Ferrel's Treatise on the Winds, Cyclones, and Tornadoes. | .8vo, | 4 00 |
| Folwell's Water Supply Engineering. | .8vo, | 4 00 |
| Frizell's Water-power. | .8vo, | 5 00 |
| Fuertes's Water and Public Health. | 12mo, | 1 50 |
| " Water Filtration Works. | (In press.) | |
| Ganguillet & Kutter's Flow of Water. (Hering & Trautwine.) | 8vo, | 4 00 |
| Hazen's Filtration of Public Water Supply. | .8vo, | 3 00 |
| Hazlehurst's Towers and Tanks for Cities and Towns. (In press.) | | |
| Herschel's 115 Experiments. | .8vo, | 2 00 |
| Kiersted's Sewage Disposal. | 12mo, | 1 25 |
| Mason's Water Supply. | .8vo, | 5 00 |
| " Examination of Water. | 12mo, | 1 25 |
| Merriman's Treatise on Hydraulics. | .8vo, | 4 00 |

| | | |
|---|------------|--------|
| Nichols's Water Supply (Chemical and Sanitary)..... | 8vo, | \$2 50 |
| Schuyler's Reservoirs for Irrigation..... | Large 8vo, | 5 00 |
| Turneure and Russell's Public Water-supplies..... | 8vo, | 5 00 |
| Wegmann's Water Supply of the City of New York..... | 4to, | 10 00 |
| Weisbach's Hydraulics. (Du Bois.)..... | 8vo, | 5 00 |
| Whipple's Microscopy of Drinking Water..... | 8vo, | 3 50 |
| Wilson's Irrigation Engineering..... | 8vo, | 4 00 |
| " Hydraulic and Placer Mining..... | 12mo, | 2 00 |
| Wolff's Windmill as a Prime Mover..... | 8vo, | 3 00 |
| Wood's Theory of Turbines..... | 8vo, | 2 50 |

LAW.

| | | |
|--|----------------|------|
| Davis's Elements of Law..... | 8vo, | 2 50 |
| " Treatise on Military Law..... | 8vo, | 7 00 |
| | Sheep, | 7 50 |
| Murray's A Manual for Courts-martial..... | 16mo, morocco, | 1 50 |
| Wait's Engineering and Architectural Jurisprudence..... | 8vo, | 6 00 |
| | Sheep, | 6 50 |
| " Law of Contracts..... | 8vo, | 3 00 |
| " Law of Operations Preliminary to Construction in En- gineering and Architecture..... | 8vo, | 5 00 |
| | Sheep, | 5 50 |
| Winthrop's Abridgment of Military Law..... | 12mo, | 2 50 |

MANUFACTURES.

| | | |
|--|----------------|-------|
| Allen's Tables for Iron Analysis..... | 8vo, | 3 00 |
| Beaumont's Woollen and Worsted Manufacture..... | 12mo, | 1 50 |
| Bolland's Encyclopædia of Founding Terms..... | 12mo, | 3 00 |
| " The Iron Founder..... | 12mo, | 2 50 |
| " " " " Supplement..... | 12mo, | 2 50 |
| Eissler's Explosives, Nitroglycerine and Dynamite..... | 8vo, | 4 00 |
| Ford's Boiler Making for Boiler Makers..... | 18mo, | 1 00 |
| Metcalf's Cost of Manufactures..... | 8vo, | 5 00 |
| Metcalf's Steel—A Manual for Steel Users..... | 12mo, | 2 00 |
| * Reising's Guide to Piece Dyeing..... | 8vo, | 25 00 |
| Spencer's Sugar Manufacturer's Handbook.... | 16mo, morocco, | 2 00 |
| " Handbook for Chemists of Beet Sugar Houses. 16mo, morocco, | | 3 00 |
| Thurston's Manual of Steam Boilers..... | 8vo, | 5 00 |
| Walke's Lectures on Explosives..... | 8vo, | 4 00 |
| West's American Foundry Practice..... | 12mo, | 2 50 |
| " Moulder's Text-book..... | 12mo, | 2 50 |
| Wiechmann's Sugar Analysis..... | Small 8vo, | 2 50 |
| Woodbury's Fire Protection of Mills..... | 8vo, | 2 50 |

MATERIALS OF ENGINEERING.

(See also ENGINEERING, p. 7.)

| | | |
|---|---------------|--------|
| Baker's Masonry Construction..... | 8vo, | \$5 00 |
| Beardslee and Kent's Strength of Wrought Iron..... | 8vo, | 1 50 |
| Bovey's Strength of Materials..... | 8vo, | 7 50 |
| Burr's Elasticity and Resistance of Materials..... | 8vo, | 5 00 |
| Byrne's Highway Construction..... | 8vo, | 5 00 |
| Church's Mechanics of Engineering—Solids and Fluids.... | 8vo, | 6 00 |
| Du Bois's Stresses in Framed Structures..... | Small 4to, | 10 00 |
| Johnson's Materials of Construction..... | 8vo, | 6 00 |
| Lanza's Applied Mechanics..... | 3vo, | 7 50 |
| Martens's Testing Materials. (Henning.)..... | 2 vols., 8vo, | 7 50 |
| Merrill's Stones for Building and Decoration..... | 8vo, | 5 00 |
| Merriman's Mechanics of Materials..... | 8vo, | 4 00 |
| " Strength of Materials..... | 12mo, | 1 00 |
| Patton's Treatise on Foundations..... | 8vo, | 5 00 |
| Rockwell's Roads and Pavements in France..... | 12mo, | 1 25 |
| Spalding's Roads and Pavements..... | 12mo, | 2 00 |
| Thurston's Materials of Construction..... | 8vo, | 5 00 |
| " Materials of Engineering..... | 3 vols., 8vo, | 8 00 |
| Vol. I., Non-metallic..... | 8vo, | 2 00 |
| Vol. II., Iron and Steel..... | 8vo, | 3 50 |
| Vol. III., Alloys, Brasses, and Bronzes..... | 8vo, | 2 50 |
| Wood's Resistance of Materials..... | 8vo, | 2 00 |

MATHEMATICS.

| | | |
|--|------------|------|
| Baker's Elliptic Functions..... | 8vo, | 1 50 |
| *Bass's Differential Calculus..... | 12mo, | 4 00 |
| Briggs's Plane Analytical Geometry..... | 12mo, | 1 00 |
| Chapman's Theory of Equations..... | 12mo, | 1 50 |
| Compton's Logarithmic Computations..... | 12mo, | 1 50 |
| Davis's Introduction to the Logic of Algebra..... | 8vo, | 1 50 |
| Halsted's Elements of Geometry..... | 8vo, | 1 75 |
| " Synthetic Geometry..... | 8vo, | 1 50 |
| Johnson's Curve Tracing..... | 12mo, | 1 00 |
| " Differential Equations—Ordinary and Partial. | Small 8vo, | 3 50 |
| " Integral Calculus..... | 12mo, | 1 50 |
| " " " Unabridged. Small 8vo. (<i>In press.</i>) | | |
| " Least Squares..... | 12mo, | 1 50 |
| *Ludlow's Logarithmic and Other Tables. (Bass.)..... | 8vo, | 2 00 |
| * " Trigonometry with Tables. (Bass.)..... | 8vo, | 3 00 |
| *Mahan's Descriptive Geometry (Stone Cutting)..... | 8vo, | 1 50 |
| Merriman and Woodward's Higher Mathematics..... | 8vo, | 5 00 |

| | | |
|--|--------------------------|--------|
| Merriman's Method of Least Squares | 8vo, | \$2 00 |
| Rice and Johnson's Differential and Integral Calculus, | | |
| | 2 vols. in 1, small 8vo, | 2 50 |
| “ Differential Calculus..... | Small 8vo, | 3 00 |
| “ Abridgment of Differential Calculus. | | |
| | Small 8vo, | 1 50 |
| Totten's Metrology..... | 8vo, | 2 50 |
| Warren's Descriptive Geometry..... | 2 vols., 8vo, | 3 50 |
| “ Drafting Instruments..... | 12mo, | 1 25 |
| “ Free-hand Drawing..... | 12mo, | 1 00 |
| “ Linear Perspective..... | 12mo, | 1 00 |
| “ Primary Geometry..... | 12mo, | 75 |
| “ Plane Problems..... | 12mo, | 1 25 |
| “ Problems and Theorems..... | 8vo, | 2 50 |
| “ Projection Drawing..... | 12mo, | 1 50 |
| Wood's Co-ordinate Geometry..... | 8vo, | 2 00 |
| “ Trigonometry..... | 12mo, | 1 00 |
| Woolf's Descriptive Geometry..... | Large 8vo, | 3 00 |

MECHANICS—MACHINERY.

(See also ENGINEERING, p. 7.)

| | | |
|--|--------------------------|------|
| Baldwin's Steam Heating for Buildings..... | 12mo, | 2 50 |
| Barr's Kinematics of Machinery..... | 8vo, | 2 50 |
| Benjamin's Wrinkles and Recipes | 12mo, | 2 00 |
| Chordal's Letters to Mechanics..... | 12mo, | 2 00 |
| Church's Mechanics of Engineering..... | 8vo, | 6 00 |
| “ Notes and Examples in Mechanics..... | 8vo, | 2 00 |
| Crehore's Mechanics of the Girder..... | 8vo, | 5 00 |
| Cromwell's Belts and Pulleys..... | 12mo, | 1 50 |
| “ Toothed Gearing..... | 12mo, | 1 50 |
| Compton's First Lessons in Metal Working..... | 12mo, | 1 50 |
| Compton and De Groodt's Speed Lathe..... | 12mo, | 1 50 |
| Dana's Elementary Mechanics | 12mo, | 1 50 |
| Dingey's Machinery Pattern Making..... | 12mo, | 2 00 |
| * Dredge's Trans. Exhibits Building, World Exposition. | | |
| | Large 4to, half morocco, | 5 00 |
| Du Bois's Mechanics. Vol. I., Kinematics | 8vo, | 3 50 |
| “ “ Vol. II., Statics..... | 8vo, | 4 00 |
| “ “ Vol. III., Kinetics..... | 8vo, | 3 50 |
| Fitzgerald's Boston Machinist..... | 18mo, | 1 00 |
| Flather's Dynamometers..... | 12mo, | 2 00 |
| “ Rope Driving..... | 12mo, | 2 00 |
| Hall's Car Lubrication..... | 12mo, | 1 00 |
| Holly's Saw Filing | 18mo, | 75 |

| | | |
|--|-----------------|--------|
| Johnson's Theoretical Mechanics. An Elementary Treatise. (<i>In the press.</i>) | | |
| Jones's Machine Design. Part I., Kinematics..... | .8vo, | \$1 50 |
| " " " Part II., Strength and Proportion of Machine Parts..... | .8vo, | 3 00 |
| Lanza's Applied Mechanics..... | .8vo, | 7 50 |
| MacCord's Kinematics..... | .8vo, | 5 00 |
| Merriman's Mechanics of Materials..... | .8vo, | 4 00 |
| Metcalf's Cost of Manufactures..... | .8vo, | 5 00 |
| *Michie's Analytical Mechanics..... | .8vo, | 4 00 |
| Richards's Compressed Air..... | .12mo, | 1 50 |
| Robinson's Principles of Mechanism..... | .8vo, | 3 00 |
| Smith's Press-working of Metals..... | .8vo, | 3 00 |
| Thurston's Friction and Lost Work..... | .8vo, | 3 00 |
| " The Animal as a Machine..... | .12mo, | 1 00 |
| Warren's Machine Construction..... | .2 vols., .8vo, | 7 50 |
| Weisbach's Hydraulics and Hydraulic Motors. (Du Bois.).. | .8vo, | 5 00 |
| " Mechanics of Engineering. Vol. III., Part I., Sec. I. (Klein.)..... | .8vo, | 5 00 |
| Weisbach's Mechanics of Engineering. Vol. III., Part I., Sec. II. (Klein.)..... | .8vo, | 5 00 |
| Weisbach's Steam Engines. (Du Bois.)..... | .8vo, | 5 00 |
| Wood's Analytical Mechanics..... | .8vo, | 3 00 |
| " Elementary Mechanics..... | .12mo, | 1 25 |
| " " " Supplement and Key..... | .12mo, | 1 25 |

METALLURGY.

| | | |
|---|------------|-------|
| Allen's Tables for Iron Analysis..... | .8vo, | 3 00 |
| Egleston's Gold and Mercury..... | Large 8vo, | 7 50 |
| " Metallurgy of Silver..... | Large 8vo, | 7 50 |
| * Kerl's Metallurgy—Steel, Fuel, etc..... | .8vo, | 15 00 |
| Kunhardt's Ore Dressing in Europe..... | .8vo, | 1 50 |
| Metcalf's Steel—A Manual for Steel Users..... | .12mo, | 2 00 |
| O'Driscoll's Treatment of Gold Ores..... | .8vo, | 2 00 |
| Thurston's Iron and Steel..... | .8vo, | 3 50 |
| " Alloys..... | .8vo, | 2 50 |
| Wilson's Cyanide Processes..... | .12mo, | 1 50 |

MINERALOGY AND MINING.

| | | |
|--|-------------------|------|
| Barringer's Minerals of Commercial Value.... | Oblong morocco, | 2 50 |
| Beard's Ventilation of Mines..... | .12mo, | 2 50 |
| Boyd's Resources of South Western Virginia..... | .8vo, | 3 00 |
| " Map of South Western Virginia.... | Pocket-book form, | 2 00 |
| Brush and Penfield's Determinative Mineralogy. New Ed. | .8vo, | 4 00 |

MISCELLANEOUS PUBLICATIONS.

| | |
|---|--------|
| Alcott's Gems, Sentiment, Language.....Gilt edges, | \$5 00 |
| Emmon's Geological Guide-book of the Rocky Mountains.. 8vo, | 1 50 |
| Ferrel's Treatise on the Winds.....8vo, | 4 00 |
| Haines's Addresses Delivered before the Am. Ry. Assn...12mo, | 2 50 |
| Mott's The Fallacy of the Present Theory of Sound..Sq. 16mo, | 1 00 |
| Richards's Cost of Living.....12mo, | 1 00 |
| Ricketts's History of Rensselaer Polytechnic Institute.... 8vo, | 3 00 |
| Rotherham's The New Testament Critically Emphasized. | |
| 12mo, | 1 50 |
| " The Emphasized New Test. A new translation. | |
| Large 8vo, | 2 00 |
| Totten's An Important Question in Metrology.....8vo, | 2 50 |

HEBREW AND CHALDEE TEXT-BOOKS.

FOR SCHOOLS AND THEOLOGICAL-SEMINARIES.

| | |
|---|------|
| Gesenius's Hebrew and Chaldee Lexicon to Old Testament. (Tregelles).....Small 4to, half morocco, | 5 00 |
| Green's Elementary Hebrew Grammar.....12mo, | 1 25 |
| " Grammar of the Hebrew Language (New Edition).8vo, | 3 00 |
| " Hebrew Chrestomathy.....8vo, | 2 00 |
| Letteris's Hebrew Bible (Massoretic Notes in English). | |
| 8vo, arabesque, | 2 25 |

MEDICAL.

| | |
|---|------|
| Hammarsten's Physiological Chemistry. (Mandel.)..... 8vo, | 4 00 |
| Mott's Composition, Digestibility, and Nutritive Value of Food. | |
| Large mounted chart, | 1 25 |
| Ruddiman's Incompatibilities in Prescriptions.....8vo, | 2 00 |
| Steel's Treatise on the Diseases of the Dog..... 8vo, | 3 50 |
| Woodhull's Military Hygiene.....16mo, | 1 50 |
| Worcester's Small Hospitals—Establishment and Maintenance, including Atkinson's Suggestions for Hospital Archi- tecture.....12mo, | 1 25 |



7 - 100 -

| | | |
|-----------|-----|-----------------|
| Temp oil | 1 - | } <u>guards</u> |
| Temp room | 2 - | |
| Temp feed | 3 - | |
| Temp in C | 4 - | |
| " L.C. | 5 - | |

Temp flux. ?

Draft gages

UNIVERSITY OF CALIFORNIA LIBRARY

THIS BOOK IS DUE ON THE LAST DATE
STAMPED BELOW

MAY 14 1914

NOV 3 1914

SEP 19 1917

NOV 8 1917

SEP 22 1920

JUN 5 4 1914 45

REC'D CIRC DEPT

JUN 18 '21

30m-6,'14

YC 12765

1 Kent

92386

TJ 285

A 3

