

STEAM BOILERS  
ENGINES & TURBINES

LIBRARY  
OF THE  
UNIVERSITY OF CALIFORNIA.

*Class*











STEAM BOILERS, ENGINES, AND  
TURBINES







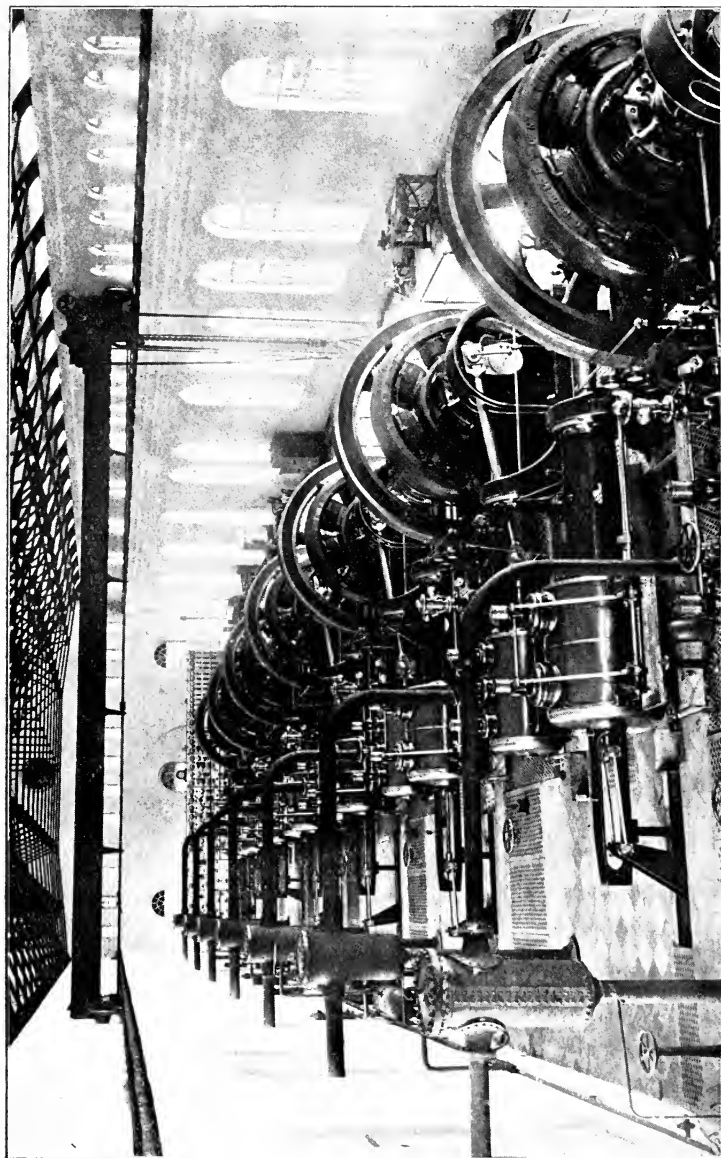

Modern Electricity Generating Station, consisting of Seven Sets of Marshall-Cross Compound Condensing Engines, with Continuous Current Generators mounted on the Crank-shafts. The Units are of 200 kilowatts, the Jet Condensers having Vertical Air Pumps worked by Tail-end Rocking Shafts, [Frontispiece.

# STEAM BOILERS, ENGINES AND TURBINES

BY

SYDNEY F. WALKER

M.I.E.E., M.INST.M.E., M.I.M.E., ASSOC.M.I.C.E., ETC.

AUTHOR OF "ELECTRICITY IN MINING," ETC.

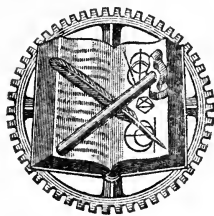

NEW YORK

D. VAN NOSTRAND COMPANY

23 MURRAY AND 27 WARREN STREETS

1908

TJWAS  
W2

GENERAL

## P R E F A C E

IN the following pages the author has endeavoured to set forth the principles and practice of steam, as they are understood by modern engineers, for the use of the student, using the term in its wide sense, viz. to include all those to whom a knowledge of steam and of steam-using apparatus will be of service. With the universal employment of power, a knowledge of the properties of steam is becoming daily of more and more importance to engineers of all branches, and to large numbers of business men and others who are not directly engaged in the practical application of steam appliances.

The author has endeavoured to set out, in simple language, and with the aid of only the very simplest forms of mathematics, the properties of water, of steam, of air, and of the gases that enter into the process of combustion, and he has also endeavoured to give a *resumé* of the latest practice in steam, and a description of the latest appliances for its economical generation and use. With the ever-increasing demands for power, and with the repeated warnings from scientists of the possible shortness of coal, and again with the steadily increasing cost of mining coal in the United Kingdom, sources of economy in the use of steam, it has appeared to the author, are of increasing importance; and he has endeavoured to give a clear and simple explanation of the different apparatus designed to produce economy, and of the leading forms on the market.

The book is divided into six chapters. In the first chapter the author has dealt with the underlying principles upon which the use of steam apparatus is based. In the second chapter he has described the principles and construction, and, as far as space has allowed, the working of the different forms of boilers on the market. In the third chapter he has dealt with the apparatus designed to effect economies in the consumption of fuel. In the remaining chapters

he has dealt with the construction, arrangement, and working of reciprocating engines, turbines, and condensers, and with the apparatus designed for economies in steam consumption, in the cost of condensing, etc. He trusts that the book may be of service to those for whom it is written, and may be an aid to the heavier books on steam, steam engines, etc.

SYDNEY F. WALKER.

1, BLOOMFIELD CRESCENT,  
BATH.



# CONTENTS

## CHAPTER I

### INTRODUCTORY

	PAGE
What heat is . . . . .	1
The ether . . . . .	1
Properties of heat waves . . . . .	2
Temperature . . . . .	4
Absolute temperature . . . . .	5
Measurement of temperatures . . . . .	5
The expansion pyrometer . . . . .	6
Thermo-electric pyrometers . . . . .	7
Entropy . . . . .	9
Transmission of heat . . . . .	9
Thermal conductivity of finely divided substances . . . . .	12
Specific heat . . . . .	13
The British thermal unit . . . . .	13
The mechanical equivalent of heat . . . . .	15
The rate of doing work . . . . .	15
Expansion of bodies in the presence of heat . . . . .	16
Latent heat . . . . .	16
The variation of the boiling-point . . . . .	18
The influence of dissolved substances upon the boiling-point of water . . . . .	21
Absolute pressure . . . . .	22
Variation of the latent heat with variation of pressure . . . . .	22
Properties of saturated steam . . . . .	24
Air . . . . .	25
Volume and weight of air at various temperatures . . . . .	26
Measuring the percentage of vapour in air . . . . .	28
Volume and pressure . . . . .	29
The specific heat of air . . . . .	29
Water . . . . .	31
Impurities in water . . . . .	33
Steam . . . . .	34
Superheated steam . . . . .	35
Specific heat of superheated steam . . . . .	36
Carnot's law of the efficiency of heat engines . . . . .	36
Fuel and combustion . . . . .	37
Calorific power . . . . .	38
Forms of fuel . . . . .	39
Coal . . . . .	39
Forms of coal . . . . .	40
Cannel coal . . . . .	41
The differences between coals . . . . .	42
Carbon and volatile matter in coals . . . . .	42
Calorimetry . . . . .	43

	PAGE
Wood . . . . .	44
Spent tan, straw, bagasse, corn stalks, and other organic refuse . . . . .	45
Liquid fuels . . . . .	46
Flash point and ignition point . . . . .	47
Gas tar as a fuel . . . . .	48
Burning liquid fuels . . . . .	49
Gaseous fuel . . . . .	49
Producer gas . . . . .	49
Blast furnace gas . . . . .	50
Coke oven gas . . . . .	51
Natural gas . . . . .	51
Gases found in collieries . . . . .	52

## CHAPTER II

*BOILERS*

The steam boiler . . . . .	53
Circulation in boilers . . . . .	54
Fire-tube boilers . . . . .	55
Galloway cone tubes . . . . .	59
The construction of Lancs. and Cornish boilers . . . . .	60
Lancs. and Cornish boiler flues . . . . .	63
Corrugated flues and furnaces . . . . .	64
Setting Cornish and Lancs. boilers . . . . .	68
Firing Lancs. and Cornish boilers from outside . . . . .	69
The Galloway boiler . . . . .	70
Multitubular boilers . . . . .	70
Forms of multitubular boiler . . . . .	72
The ordinary multitubular boiler . . . . .	72
The locomotive type of boiler . . . . .	73
The marine boiler . . . . .	73
The dry back boiler . . . . .	74
Combined Cornish and multitubular boilers . . . . .	76
Water-tube boilers . . . . .	77
An advantage claimed for water-tube boilers with high pressures . . . . .	79
Convenience of transport of water-tube boilers . . . . .	81
The water circulation in water-tube boilers . . . . .	81
The furnace of water-tube boilers . . . . .	82
Forms of water-tube boilers . . . . .	82
The Stirling water-tube boiler . . . . .	84
The Nesdrum water-tube boiler . . . . .	87
The Woodeson water-tube boiler . . . . .	88
Water-tube boilers with horizontal or nearly horizontal tubes . . . . .	90
Marshall's water-tube boiler . . . . .	91
Davey, Paxman's water-tube boiler . . . . .	91
The Wood water-tube boiler . . . . .	92
The Galloway water-tube boiler . . . . .	93
American boilers with straight, or nearly straight, horizontal tubes . . . . .	93
The Atlas water-tube boiler . . . . .	93
The water purifying apparatus of the Atlas boiler . . . . .	95
The Heine and the Detroit water-tube boilers . . . . .	95
Water-tube boilers with vertical tubes . . . . .	96
Water-tube boilers with curved tubes . . . . .	98
The Climax water-tube boiler . . . . .	98
Thornycroft water-tube boilers . . . . .	99
Thornycroft-Schultz boiler . . . . .	100
The Taylor water-tube boiler . . . . .	104
Small vertical boilers . . . . .	104
The Straker motor-wagon boiler . . . . .	105

## CHAPTER III

*BOILER ACCESSORIES*

	PAGE
Burning the fuel . . . . .	107
Special forms of furnace bars . . . . .	108
Apparatus for burning coal dust . . . . .	110
Apparatus for burning liquid fuel.—The Holden System . . . . .	111
Liquid fuel burners.—Marshall's Apparatus . . . . .	112
Burning town's refuse . . . . .	113
Meldrum's colliery refuse destructor . . . . .	114
Mechanical stokers . . . . .	115
Forms of mechanical stoker . . . . .	117
The grate bars of over-feed stokers . . . . .	120
The Auto stoker . . . . .	122
Vicars mechanical stoker . . . . .	123
Chain-grate stokers . . . . .	124
Under-feed stokers . . . . .	125
Providing the air for the furnace . . . . .	127
Chimney draught . . . . .	127
Sizes of chimneys and horse-power of boilers . . . . .	131
The factors ruling the height of a chimney . . . . .	133
Construction of boiler chimneys . . . . .	137
Forced draught . . . . .	139
Induced draught . . . . .	141
Induced draught combined with heating of the air for the furnace . . . . .	143
Forms of fans employed for mechanical draught . . . . .	145
Sizes of fan required . . . . .	146
Draught by means of steam jets . . . . .	147
Boiler dampers . . . . .	148
Automatic damper regulators . . . . .	149
The Lagonda damper regulator . . . . .	149
Boiler cleaners . . . . .	150
Turbine boiler-tube cleaners . . . . .	151
Boiler fittings . . . . .	151
Safety valves . . . . .	152
Atmospheric relief valve . . . . .	155
High and low water safety apparatus . . . . .	155
Combined stop and safety valve . . . . .	156
Heating the feed water for the boilers . . . . .	156
Economizers . . . . .	158
Green's Economizer . . . . .	160
Heating air and water by economizers . . . . .	162
Steam feed-water heaters . . . . .	163
The enclosed steam feed-water heaters . . . . .	163
Open steam feed-water heaters . . . . .	168
Feed-water pumps . . . . .	170
Ram pumps . . . . .	170
Special pumps . . . . .	170
The Pulsometer feed pump . . . . .	171
Electrically driven boiler feed pumps . . . . .	172
Donkey or wall pumps . . . . .	173
Injectors . . . . .	173
Feed-water regulators . . . . .	178
Purifying the feed water . . . . .	179
Other scale-forming substances . . . . .	181
Methods of removing foreign bodies, etc. . . . .	181

	PAGE
Water softeners . . . . .	182
The Archbutt-Deeley water softener . . . . .	183
The Criton water softener . . . . .	184
The Reisert water softener . . . . .	186
The Bruun Lowener water softener . . . . .	187
Guttman water softener . . . . .	188
Doulton's water softener . . . . .	188
The Kennicott water softener . . . . .	189
The Desrumeaux water softener . . . . .	190
The Arthur Koppel water softener . . . . .	191
Harris-Anderson water softener . . . . .	192
Removing the oil from the water . . . . .	193
Oil separators . . . . .	193
Cochrane vacuum oil separator . . . . .	195
Reid oil separators . . . . .	195
A steam exhaust head and oil catcher . . . . .	197
Special apparatus for removing oil . . . . .	197
Davis-Perrett's electrical emulsifier . . . . .	198
Superheating the steam . . . . .	199
Forms of superheating apparatus . . . . .	200
The Babcock Wilcox . . . . .	200
The Stirling superheater . . . . .	201
The Nesdrum Superheater . . . . .	202
The Sinclair Superheater . . . . .	203
The Galloway Superheater . . . . .	203
The Tinker Superheater . . . . .	203
Steam separators . . . . .	203
The Marriot Steam Separator . . . . .	203
Evaporators . . . . .	204
Apparatus for testing the flue gases in the chimney . . . . .	205
The Sarco automatic CO <sub>2</sub> recorder . . . . .	208
The Simmance and Abady CO <sub>2</sub> recorder . . . . .	211
The Orsat apparatus for flue gas analysis . . . . .	212

## CHAPTER IV

*THE STEAM ENGINE*

The reciprocating steam engine . . . . .	213
The mean effective pressure . . . . .	215
The work a steam engine will perform . . . . .	218
Indicated horse-power and brake horse-power . . . . .	219
Double-cylinder engines . . . . .	220
Compound Engines . . . . .	221
Triple-expansion engines . . . . .	226
Quadruple-expansion engines . . . . .	227
High- and low-speed engines . . . . .	227
The Ernest Scott and Mountain high-speed engine . . . . .	232
The Willans central valve engine . . . . .	232
Bunsted high-speed engine . . . . .	236
The Peache engine . . . . .	237
Vertical and horizontal engines . . . . .	239
Lancashire mill engines . . . . .	240
Reciprocating valves for engines . . . . .	242
The slide valve . . . . .	243
Giving motion to the slide valve . . . . .	246
Objections to the slide valve . . . . .	247
Lap and lead of slide valve . . . . .	248

# CONTENTS

xi

	PAGE
The piston slide valve . . . . .	248
Drop valves . . . . .	249
The piston drop valve . . . . .	250
Cornish valves . . . . .	250
The Corliss valve . . . . .	251
The Hill or Wheelock valve . . . . .	253
Stop valves . . . . .	254
The parallel slide stop valve . . . . .	256
Centre pressure stop valve . . . . .	257
Taking the power from the piston . . . . .	260
The government of engines . . . . .	265
The indicator . . . . .	270
Steam pipes . . . . .	273
Water hammer . . . . .	275
The arrangement of steam pipes . . . . .	278
Steam traps . . . . .	280
Brooke's steam trap . . . . .	281
Sirius steam trap . . . . .	282
The Lancaster steam trap . . . . .	283
The water-seal steam trap . . . . .	284
Steam traps operating by the expansion of a volatile spirit . . . . .	285
The Reservoir steam trap . . . . .	286
The Euston steam trap . . . . .	286
The Anderson trap . . . . .	286
Relief valves . . . . .	287

## CHAPTER V

### *THE STEAM TURBINE*

Classes of steam turbines . . . . .	288
Difference between pressure and impulse turbines . . . . .	291
Compounding in pressure turbines . . . . .	292
Forms of pressure turbine . . . . .	292
The Parsons Turbine . . . . .	292
Bearings of Parsons turbines . . . . .	295
Governor of Parsons turbines . . . . .	296
The Willans turbine governor . . . . .	300
Lubrication of the Willans-Parsons turbine . . . . .	300
The Brush-Parsons turbine . . . . .	300
The De Laval turbine . . . . .	301
Government of the De Laval turbine . . . . .	303
Transmitting the power of the De Laval turbine wheel . . . . .	305
The Curtis turbine . . . . .	309
Governing the Curtis turbine . . . . .	311
Test of a 1500 Kilowatt Curtis turbo generator . . . . .	313
Westinghouse turbine . . . . .	313
The Rateau turbine . . . . .	315
The A.E.G. steam turbine . . . . .	316
The Zoelly turbine . . . . .	317
The Hamilton Holzwarth steam turbine . . . . .	321
The forms of buckets and blades of steam turbines . . . . .	322
Turbines working with exhaust steam . . . . .	322
Turbines and condensing . . . . .	327
Turbines and superheated steam . . . . .	328

## CHAPTER VI

*CONDENSING PLANT*

	PAGE
The condenser . . . . .	330
Forms of condenser . . . . .	331
The surface condenser . . . . .	331
The evaporative surface condenser . . . . .	334
Fraser's evaporative condenser . . . . .	335
The Wheeler surface condenser . . . . .	336
Open tank surface condensers . . . . .	338
The Contraflo condenser . . . . .	338
Jet condensers . . . . .	340
The Mirrlees-Watson jet condenser . . . . .	341
The Worthington jet condenser . . . . .	341
The Ejector condenser . . . . .	343
The Barometric condenser . . . . .	344
Parsons vacuum augments . . . . .	347
Central condensing stations . . . . .	348
The quantity of cooling water required for condensing . . . . .	349
Mr. Richard Allen's experiments on condensers . . . . .	352
Prof. Weighton's experiments on condensers . . . . .	360
Pumps for condensers . . . . .	363
Air pumps . . . . .	365
Bucket air pumps . . . . .	366
Cooling the circulating water for condensers . . . . .	367
Cooling ponds . . . . .	368
Cooling ponds with nozzles . . . . .	369
Cooling towers . . . . .	370
Cooling towers without vertical draught . . . . .	371
Chimney cooling towers . . . . .	372
The cooling tower with fan draught . . . . .	375
Apparatus used in cooling towers . . . . .	376
A convex splash bar cooling tower . . . . .	378
Construction of cooling towers . . . . .	379
INDEX . . . . .	381



# LIST OF ILLUSTRATIONS

FIG.	PAGE
1. Diagram of connections of Crompton's thermo-electric pyrometer . . . . .	8
2. Crompton's thermo-electric pyrometer arranged for pipe . . . . .	8
3. Arrangement of Crompton's thermo-electric pyrometer for flue . . . . .	8
4. Bristol's thermo-electric pyrometer . . . . .	9
5. Sectional drawing of internally fired "Cornish" and multitubular boiler, made by Messrs. Marshall . . . . .	56
6. Sectional drawing of Lancs. boiler with cone tubes . . . . .	57
7. Section of Adamson original flange seam for Lancs. boiler flues . . . . .	63
8. Section of Adamson absorber flange seam for Lancs. boiler flues . . . . .	63
9. Sectional elevation and plan of Lancs. boiler with Adamson's flues . . . . .	64
10. Longitudinal and transverse sections of Messrs. Davey and Paxman's "Economic" boiler . . . . .	75
11. Sectional view of Robb-Mumford standard boiler . . . . .	77
12. Longitudinal and transverse section of the "Stirling" boiler, with super-heater . . . . .	85
13. Sectional drawings of "Woodeson" water-tube boiler, made by Messrs. Clarke, Chapman & Co. . . . .	89
14. "Wood" water-tube boiler, made by Messrs. Fraser and Chalmers . . . . .	92
15. Sectional drawings of "Suckling" water-tube boiler . . . . .	97
16. Internal view of Climax water-tube boiler, showing the tubes, vertical steam drum, etc. . . . .	98
17. Sections of Thorneycroft water-tube boiler, "Speedy" type . . . . .	101
18. Sections of Thorneycroft water-tube boiler, "Daring" type . . . . .	102
19. Sections of "Hay" water-tube boiler . . . . .	103
20. Sectional elevation of Straker boiler for steam driven vehicles . . . . .	105
21. Furnace grate with Neil's rocking fire bars . . . . .	109
22. Neil's furnace front, with baffle plate between the furnace and fire door . . . . .	109
23. Arrangement for burning coal dust in a Lancs. boiler, by the Schwartzkopff process . . . . .	110
24. Sectional drawings of Holden's apparatus for burning liquid fuel . . . . .	111
25. Marshall's apparatus for burning liquid fuel . . . . .	112
26. Korting's liquid fuel burning apparatus . . . . .	113
27. " " " applied to a Lancs. boiler . . . . .	113
28. Meldrum's interlocking fire bars for burning refuse fuel . . . . .	115
29. Sectional drawings of Messrs. Meldrum's low-grade fuel furnace . . . . .	116
30. Sections of Lancs. boiler fitted with Proctor's shovel mechanical stoker . . . . .	117
31. Sections of Henderson's mechanical stoker . . . . .	118
32. Section of ram and hopper of Meldrum's coker stoker . . . . .	119
33. Mechanism of Wilkinson mechanical stoker . . . . .	120
34. Sections of Hodgkinson's mechanical stoker . . . . .	121
35. Section of a mechanical stoker . . . . .	121
36. Sections of the "Auto" stoker . . . . .	122
37. Section of Lancs. boiler fitted with Vicars mechanical stoker . . . . .	124
38. Section of Underfeed mechanical stoker . . . . .	125
39. Section of Underfeed stoker, showing the ram . . . . .	126

FIG.		PAGE
40.	Diagram showing course of air and hot gases, with forced draught and an economizer . . . . .	140
41.	Diagram showing course of air and hot gases in a Lancs. or Cornish boiler with induced draught and an economizer . . . . .	142
42 and 43.	Sections of Ellis and Eaves system of air-heating for marine boilers . . . . .	144
44.	Section of Lancs. boiler, fitted with Meldrum's fire bars and steam jet . . . . .	148
45.	Automatic Hydraulic damper regulator, made by Messrs. Fraser and Chalmers . . . . .	150
46.	Complete steam gauge with dial and needle . . . . .	152
47.	Steam gauge shown in Fig. 46, with dial removed . . . . .	152
48.	Sections of Lancs. boiler, with Hopkinson's flue . . . . .	153
49.	Section of Eaves' dead-weight safety valve . . . . .	154
50.	Section of high-steam pressure and low-water safety valve . . . . .	156
51.	Elevation of Green's economizer . . . . .	157
52.	Sectional plan of Green's economizer . . . . .	157
53.	Section of Green's economizer, showing tubes and enclosing brickwork . . . . .	158
54.	Plan of three Lancs. boilers, with Green's economizers . . . . .	159
55.	Elevation and plan of scrapers employed by Messrs. Green on their economizers . . . . .	160
56.	Riblet steam feed-water heater . . . . .	164
57.	Hardwick steam feed-water heater . . . . .	164
58.	Royle's feed-water heater . . . . .	165
59.	Vertical transverse section of Messrs. Royle's feed-water heater . . . . .	165
60.	Wainwright's curves for the relative heating effect . . . . .	167
61.	Messrs. Holden and Brooke's live steam feed-water heater . . . . .	167
62.	Diagram showing course of steam and water, where condensed steam is employed for boiler feed . . . . .	169
63.	Diagram showing arrangement where circulating water from condenser is employed as feed-water for boiler . . . . .	169
64.	Sectional drawing of reverberatory steam injector . . . . .	174
65.	Section of Messrs. Davies and Metcalfe's injector . . . . .	174
66.	Section of Messrs. Holden and Brooke's injector, for live steam and exhaust steam . . . . .	175
67.	Messrs. Holden and Brooke's injector for exhaust steam . . . . .	175
68.	Section of Criton water softener . . . . .	185
69.	Vertical type of Bruun Lowener water softener . . . . .	187
70.	Mixing portion of Doulton's water softener . . . . .	189
71.	Section of Desrumeaux water softener . . . . .	190
72.	Diagram showing course of water to be purified in the Harris-Anderson apparatus . . . . .	193
73.	Drawing showing Harris-Anderson water purifying apparatus . . . . .	194
74.	Sections of Reid's oil separator . . . . .	196
75.	Messrs. Holden and Brooke's exhaust head . . . . .	197
76.	Diagram of Davis-Perrett's electrical emulsifier . . . . .	198
77.	Tinker's superheater, as fitted to a Lancs. boiler . . . . .	201
78.	Schmidt's superheater arranged for heating by boiler flue gases . . . . .	202
79.	Sections of Schmidt's superheater arranged for direct firing . . . . .	202
80.	The Sims steam separator, for fixing in a horizontal pipe . . . . .	204
81.	Sectional drawing of Weir's vertical evaporator . . . . .	206
82.	Curve showing percentage of fuel lost, with different percentages of CO <sub>2</sub> , in the flue gases . . . . .	207
83.	Sectional elevation of "Sarco" flue gas-testing apparatus, made by Messrs. Sanders, Rehder, and Co. . . . .	209
84.	Diagram of Simmance and Abady flue gas-testing apparatus . . . . .	210
85.	Charts taken by Simmance and Abady's flue gas-testing apparatus . . . . .	211
86.	Diagram showing course of steam, with non-condensing simple engine . . . . .	221
87.	Diagram showing course of steam in a non-condensing compound engine . . . . .	221
88.	Single-cylinder wall engine, made by Messrs. Ransome, Sims, and Jeffries . . . . .	222
89.	Single-cylinder horizontal engine with vertical boiler, made by H. Coltman and Sons. . . . .	223

# LIST OF ILLUSTRATIONS

xv

FIG.		PAGE
90.	Section of tandem compound engine, without receiver between . . . . .	223
91.	Horizontal tandem compound condensing engine, made by E. R. and F. Turner . . . . .	224
92.	Horizontal cross-compound condensing engine, made by Ransome, Sims, and Co. . . . .	224
93.	Compound vertical engine, unenclosed, with shaft governor . . . . .	225
94.	Diagram of course of steam in a non-condensing triple expansion engine . . . . .	226
95.	Sections of Allen's enclosed high-speed engines . . . . .	229
96.	Sections of compound Belliss high-speed enclosed engine . . . . .	230
97.	Sections of Browett-Lindley compound high-speed enclosed engine. . . . .	230
98.	Section of Bumsted double-acting compound enclosed engine . . . . .	236
99.	Section of Peache high-speed single-acting enclosed engine . . . . .	237
100.	Section of cylinder of Lancs. mill engine, with " Wheelock " valves . . . . .	241
101.	Section of one form of slide valve . . . . .	244
102.	Section of another form of slide valve . . . . .	244
103.	Section of cylinder with drop valve, made by Messrs. Marshall . . . . .	250
104.	Cylinder with drop valves and trip gear . . . . .	250
105.	Corliss valves with wrist plate, made by Fulton Co., of America . . . . .	251
106.	Section of single cylinder engine, with Corliss valves, made by Atlas Co. . . . .	252
107.	Double cylinder Corliss engine made by Fishkill Co. . . . .	253
108.	One form of stop valve, made by W. H. Willcox . . . . .	254
109.	Section of stop valve, made by Messes. Alley and Maclellan . . . . .	255
110.	Section of throttle valve, made by Messrs. Alley and Maclellan . . . . .	255
111.	Hopkinson's parallel slide stop valve . . . . .	256
112.	Hopkinson's centre pressure valve, shut . . . . .	258
113.	" " " , partly open . . . . .	258
114.	" " " , full open . . . . .	258
115.	Valve for reducing pressure of steam . . . . .	259
116.	Pickering governor . . . . .	265
117.	Section of Proell's governor . . . . .	266
118.	Wilson Hartnell's expansion governor . . . . .	267
119.	Expansion governor made by Messrs. Coltman . . . . .	268
120.	Proell governor, fixed on end of crank shaft . . . . .	269
121.	Expansion shaft governor for high-speed vertical engines . . . . .	269
122.	Crosby's steam-engine indicator . . . . .	270
123.	Examples of indicator cards taken from triple expansion engine . . . . .	271
124.	One form of planimeter made by Messrs. Crosby . . . . .	272
125.	Another form of Planimeter, ditto, ditto . . . . .	272
126.	" Wedgring " coupling for steam pipes . . . . .	280
127.	Sectional view of Brooke steam trap . . . . .	281
128.	Section of discharge end of Brooke steam trap . . . . .	281
129.	Inside view of " Sirius " steam trap . . . . .	282
130.	Longitudinal section of Lancaster steam trap . . . . .	283
131.	Transverse vertical section of Lancaster steam trap . . . . .	284
132.	Section of Parsons turbine . . . . .	293
133.	Willans' arrangement of rotor and stator blades . . . . .	293
134.	Section of Willans-Parsons steam turbine . . . . .	295
135.	Section of Parsons turbine . . . . .	296
136.	Sectional drawing of Parsons steam-turbine governor . . . . .	297
137.	Parsons turbo pump . . . . .	298
138.	Cross section and plan of Parsons turbines for steamship propellers . . . . .	299
139.	Section of nozzle of De Laval turbine . . . . .	302
140.	Governor of De Laval turbine . . . . .	304
141.	Section of steam valve controlled by governor . . . . .	304
142.	Sectional plan of De Laval turbine . . . . .	306
143.	De Laval turbine directly connected to a turbine pump . . . . .	307
144.	Parts of the De Laval turbine . . . . .	307
145.	Section of part of Curtis turbine, showing two stages . . . . .	310
146.	Sectional elevation of Curtis turbine . . . . .	312
147.	Elevation of a part of an electricity generating station with Curtis turbine, etc. . . . .	314

FIG.		PAGE
148.	Plan of portion of electricity generating station . . . . .	314
149.	Section of one form of Rateau turbine . . . . .	315
150.	Section of one form of the A.E.G. steam turbine . . . . .	317
151.	Drawing of Zoelly turbine . . . . .	318
152.	Runner of Zoelly steam turbine, in plan and elevation . . . . .	319
153.	Stationary blade of Zoelly turbine . . . . .	319
154.	Governor of Zoelly turbine . . . . .	320
155.	One form of Prof. Rateau's apparatus for storing heat . . . . .	323
156.	Another form of Rateau's heat-storage apparatus . . . . .	324
157.	Diagram of steam plant at Bruay Colliery, Pas de Calais . . . . .	326
158.	Sectional drawing of surface condenser and cooling tower . . . . .	333
159.	Ledward's evaporative surface condenser . . . . .	334
160.	Wheeler surface condenser . . . . .	337
161.	Sectional drawings of Contraflo condenser . . . . .	338
162.	Section of Worthington jet condenser and pump . . . . .	341
163.	Worthington jet condenser for 1500 H.P. with pump . . . . .	342
164.	Section of Ledward ejector condenser . . . . .	343
165.	Diagram of steam and water pipes, with Ledward's ejector condenser . . . . .	344
166.	Arrangement of pipes, pumps, etc., of Bulkeley barometric condenser . . . . .	345
167.	Sectional diagram of barometric tube condenser . . . . .	346
168.	Section of Parsons vacuum augments . . . . .	347
169.	Plan and vertical section of central condensing plant, with cooling tower . . . . .	350
170.	Allen's curves showing steam and coal consumption, etc., with different vacua . . . . .	353
171.	Allen's curves showing steam and coal consumption . . . . .	354
172.	Allen's curves showing coal saved, consumption of steam and condensing plant, etc. . . . .	355
173.	Allen's curves showing quantities of circulating water, with different vacua . . . . .	357
174 and 175.	Curves showing different quantities of circulating water . . . . .	358
176 and 177.	Curves similar to Figs. 174 and 175 . . . . .	359
178.	Curves showing results of Prof. Weighton's experiments . . . . .	362
179.	Curves showing results of Prof. Weighton's experiments . . . . .	362
180.	Curves showing cost in H.P. in circulating cooling water . . . . .	364
181.	Curves showing Prof. Weighton's experiments . . . . .	364
182.	Section of Edwards air pump . . . . .	366
183.	Diagram of course of water when cooling tower is used . . . . .	368
184.	Cooling tower for wind draught . . . . .	371
185.	Section of chimney cooling tower . . . . .	373
186.	Barnard chimney cooling tower . . . . .	373
187.	Another form of Barnard chimney cooling tower . . . . .	374
188.	Balcke fan-cooling tower . . . . .	376
189.	Worthington fan-cooling tower . . . . .	378

# LIST OF PLATES

PLATE	TO FACE PAGE
Modern electricity generating station, with Marshall's cross compound condensing engines . . . . .	48
	<i>Frontispiece.</i>
1A. Galloway Cornish boiler, with cone tubes . . . . .	48
1B. Battery of Lancashire boilers, Rushton, Proctor and Co. . . . .	48
2A. Galloway Lancashire boiler, with cone tubes . . . . .	64
2B. Battery of Galloway Lancashire boilers, adapted for burning low grade fuel . . . . .	64
2C. Galloway multitubular boiler, with external firing . . . . .	64
3A. Galloway boiler arranged for burning wood . . . . .	72
3B. Atlas externally fired multitubular boiler . . . . .	72
3C. Locomotive type of boiler, by Messrs. Marshall . . . . .	72
4A. Three furnace marine boiler, by Central Engineering Works . . . . .	80
4B. Thornycroft water-tube boilers . . . . .	80
5A. Babcock water-tube boiler . . . . .	88
5B. Marshall water-tube boiler . . . . .	88
6A. Atlas water-tube boiler . . . . .	96
6B. White boiler for steam cars . . . . .	96
7A. Meldrum's low-grade fuel furnace . . . . .	112
7B. Water-tube boiler fitted with chain-grate stokers . . . . .	112
8A. Proctor's mechanical stoker . . . . .	128
8B. Babcock's chain-grate stoker (front) . . . . .	128
8C. " " " " (back) . . . . .	128
9A. Hoppes' feed-water heater, and purifier . . . . .	160
9B. Deposit from Hoppes' feed-water heater . . . . .	160
9C. Hoppes' apparatus fitted to water-tube boiler . . . . .	160
10A. Evaporator by Central Engineering Works . . . . .	176
10B. Tangye single cylinder horizontal engine . . . . .	176
10C. Marshall's single cylinder horizontal engine . . . . .	176
10D. Tangye single cylinder vertical engine . . . . .	176
11A. Ruston's compound engine, tandem, with trip gear . . . . .	192
11B. Ditto " " " " " . . . . .	192
11C. Ditto " " " " " . . . . .	192
12. Adamson's Lancashire mill engine, horizontal, triple expansion . . . . .	208
13A. Galloway's vertical cross compound engine . . . . .	224
13B. Marshall's cross compound engine, horizontal . . . . .	224
13C. Marshall's tandem compound engine, horizontal . . . . .	224
14A. Ruston's tandem compound horizontal engine . . . . .	232
14B. Marshall's coupled compound condensing engine, with rope drive to dynamo . . . . .	232
15A. Triple expansion marine engine by Central Engineering Works . . . . .	240
15B. Single cylinder Corliss engine, by Atlas Co. . . . .	240
15C. Vertical compound enclosed engine with steam separator . . . . .	248
16. Bumsted single cylinder vertical encased engine . . . . .	248
17A. Horizontal cross-compound engine, with rope drive, for Lancashire mills . . . . .	256

PLATE		PAGE
17B.	Trip valve gear and governor, made by Easton and Bessemer . . . . .	256
18A.	Rotor of Brush-Parsons' steam turbine . . . . .	280
18B.	Half of stator of Brush-Parsons' turbine . . . . .	280
18C.	Brush-Parsons' turbine, connected to alternator and its excitor . . . . .	280
19A.	Parsons' turbine, with steam and oil connections, etc. by Richardson and Westgarth . . . . .	288
19B.	Richardson's Westgarth-Parsons' steam turbine, from steam end . . . . .	288
19C.	Richardson's Westgarth-Parsons' steam turbine, from generator end . . . . .	288
20A.	De Laval turbine, with gearing and pulleys by Greenwood and Batley . . . . .	296
20B.	De Laval turbine, with gearing directly connected to a 150 H.P. De Laval turbine pump . . . . .	296
21A.	De Laval turbine connected to a 60 H.P. De Laval turbine pump . . . . .	304
21B.	De Laval turbine connected to De Laval 15 H.P. turbine pump . . . . .	304
22A.	De Laval turbine directly connected to a fan . . . . .	312
22B.	A Zoelly turbine, made by Escher, Wyss, and Co. . . . .	312
23A.	Complete Contraflo condenser . . . . .	328
23B.	Contraflo condenser, with air pump . . . . .	328
24A.	Condensing plant for a pair of blowing engines . . . . .	336
24B.	Tangye duplex double-acting steam pump . . . . .	336
25A.	Pair of vertical double-acting pumps, by Mirrlees Watson Co. . . . .	344
25B.	Hall's vertical duplex steam pump . . . . .	344
25C.	Surface condenser, with two-cylinder Edwards' air pump . . . . .	344
25D.	Hall's single vertical steam pump . . . . .	344
26A.	Two-stage horizontal steam-driven slide-valve dry-air pump, by Mirrlees Watson Co. . . . .	352
26B.	Two-throw steam-driven slide-valve dry-air pumps, by Mirrlees Watson Co. . . . .	352
26C.	Three-throw Edwards' air pump, electrically driven . . . . .	352
27A.	Single-throw vertical Edwards' air pump, by Mirrlees Watson Co. . . . .	368
27B.	Three-throw vertical Edwards' air pump, by Mirrlees Watson Co. . . . .	368
27C.	Mirrlees Watson surface condensing plant . . . . .	368



# STEAM BOILERS, ENGINES, AND TURBINES

## CHAPTER I

### INTRODUCTORY

#### What Heat is

ACCORDING to the latest theory, and the only one so far as the author is aware that is at present in vogue, what we know as heat is a wave motion in the ether. The theory is known sometimes as the mechanical theory of heat, and sometimes as the wave theory.

Every one is familiar with the experiment that is mentioned in heat and light text-books, of a boy throwing a stone in the water, and the circles of waves which follow. Most of us also have watched the waves which are pushed out from the bow of a steamer, as it cleaves its way through the water. We have also, most of us, sat on the sea-shore and watched the waves come rippling up, one after the other, at our feet. We notice two or three characteristics about the circular waves. They are continually moving onward, and in the case of the waves created by a stone thrown in the water, with ever increasing diameter and ever decreasing force. We notice also that as a wave moves onward, the water rises as the wave meets it, falling afterwards, rising with the next wave, and so on, and we may notice that the water through which the wave passes, does not move on, though the wave does. A cork floating on the water bobs up and down, as it forms the crest or the trough of the wave, but remains practically stationary, unless it is carried on by a tide or river current.

#### The Ether

The ether is the substance which is supposed by scientists to pervade all space. It is the substance, the sea it may be termed, in

which our earth, our sun and the other planets, and the other worlds we call heavenly bodies, are all floating. Further, the ether is all pervading. It not only fills the space between the planetary and other celestial bodies, but it is present in every substance. Every substance, as we know, is more or less porous. We are familiar with the fact that a sponge holds water in its pores. All substances, and all bodies, are porous in a similar sense, to the ether. The waves by which heat is transmitted, and the waves by which the presence of heat is denoted, pass through the ether, not only in coming from the sun to us, but in the ether held in every substance. Thus, when we say that a body is heated to a certain temperature, as the author understands it, we mean that a certain wave motion is going on in the ether held in the ethereal pores of that body. According to the modern view, all heat comes to us from the sun. The earth itself contains a certain quantity of heat in its substance, but this also originally came from the sun, inasmuch as modern views suppose that the earth and the other planets originally formed parts of the body of the sun, and were thrown out by him at various times, the different portions that have since become different planets having gradually cooled as they whirled through space. A certain quantity of heat reaches us from the other planets of the solar system, and from the myriads of other worlds to be seen through a telescope, and the other myriads that are still invisible to the most powerful telescope; but the sum of the heat which reaches us from all of these is but a small fraction of that coming to us daily from the sun, and we may therefore say that, for practical purposes, all heat comes to us from the sun.

### Properties of Heat Waves

Heat waves have certain properties, and they are closely allied to light waves. If we take a diagram of the spectrum, in which the lengths of the waves of heat and different forms of light are shown, we shall notice that heat waves are longer than light waves, but in every other respect they are similar. What appears to our senses as white light, as we know, is made up of a number of colours, as shown in the rainbow, and that can be produced by passing a ray of light through a glass prism. As we know, in the rainbow and in the spectrum produced by the glass prism, the prismatic colours, as they are called, run from left to right as follows. Red on the extreme left, violet on the extreme right, yellow in the middle, orange, green, blue occupying intermediate positions. The wave lengths of the red rays are approximately twice that of the violet rays, and consequently the rate of motion of the violet rays is twice that of the red rays. The figures are  $\frac{1}{33000}$  inch for the red rays, and  $\frac{1}{66000}$  inch for the violet rays. Outside of the red rays,

still further to the left of the spectrum, heat rays are present, known sometimes as the infra red rays, and sometimes as the dark or invisible rays. They are the heat rays of which we are sensible when emanating from a black heated body, such as a hot kettle, or saucepan, or poker. The waves of these rays are longer than the red rays, and have a slower rate. To the right again of the violet rays, there is another large space occupied by invisible rays, whose wave length is shorter than that of the violet, and whose period is higher. These waves are known as the actinic, or chemical rays, from the properties which they possess. It is the violet and the ultra violet rays, as they are sometimes called, that are so useful in photography, and that are so troublesome to the housekeeper at times in destroying the colours of fabrics used in furniture. The waves comprised in the whole range of the spectrum, and the portions mentioned beyond the spectrum, have other important properties. They are capable of reflection, refraction, and polarization.

We all know what is meant by reflection. We all make use of it when we look in a mirror. The light rays impinge on our bodies, are reflected from them to the mirror, and reflected out again to our eyes, and we see the reflected image of ourselves in the mirror. Light rays are reflected by plane mirrors in this manner, and in accordance with a certain law, viz. the angle of incidence = the angle of reflection. That is to say, the angle which the impinging ray makes with the plane of the mirror is equal to the angle which the ray passing out makes with it.

Heat rays are reflected by plain metallic and certain other substances, in the same manner as light rays are reflected by mirrors, and follow the same laws.

Heat and light rays are also reflected by curved surfaces, the reflections following the same law that has been given above, the angle of incidence being equal to the angle of reflection, and this leads to the divergent rays impinging upon concave surfaces being brought together in one point known as the focus. This fact is of importance in certain cases.

Heat and light rays are also refracted. That is to say, they are bent in passing through different substances. Every substance offers a certain resistance to the passage of both heat and light rays, and this resistance apparently leads to alteration in the direction of the rays in different media. The alteration in the direction or the bending is different for the different waves. The waves of shorter length are bent less. The law is as follows. The incident and refracted rays are in the same plane as a normal to the surface upon which the ray impinges, and the sines of the angles of inclination of the two rays are in a constant ratio, for the same wave length, and the same media. This constant ratio is called the refractive index.

When a ray of heat or light passes from a rarer into a denser medium, the angle of refraction, the angle which the refracted ray makes with the normal to the common surface is less than the angle of incidence, the angle which the impinging ray makes with the normal to the surface, and *vice versa*.

**Polarization** need not trouble us ; it merely means the property which certain crystals have, when cut in a certain way, of stopping certain rays. The only point to note is that all the properties of reflection and polarization are common to both heat and light rays.

## Temperature

Temperature is in heat, what pressure is in mechanics, and in electricity. Heat passes from a higher to a lower temperature, just as electricity does from a higher to a lower pressure, and just as a weight falls from a higher to a lower level. There are three scales by which heat is measured, known respectively as the Fahrenheit, Centigrade, and Reaumur. The Reaumur scale is not now often seen or used in calculations, but Fahrenheit and Centigrade are in constant use. The Fahrenheit may be taken to be the scale employed more in everyday life ; the Centigrade, that used in scientific calculations. The Centigrade thermometer is also sometimes known as the Celsius—Celsius, Fahrenheit, and Reaumur being the introducers of the respective scales. All of the scales are based upon two well-known fixed points of temperature, viz. that at which ice commences to melt into water, and that at which water commences to form steam, both being at the barometric pressure, 29.96 inches, that is used in all standard calculations, and at sea-level. As will be seen later, the boiling-point of water, the temperature at which it commences to form steam, varies with the pressure to which it is subject. In the Centigrade scale, the temperature at which ice commences to melt, or the freezing-point of water, as it is usually expressed, is taken as  $0^{\circ}$ , and the temperature at which steam commences to form water is taken at  $100^{\circ}$  ; hence the name of the scale. In the Fahrenheit scale, the freezing-point of water is taken at  $32^{\circ}$ , and the boiling-point of water at  $212^{\circ}$ . In the Reaumur scale, the freezing-point is taken as  $0^{\circ}$ , and the boiling-point as  $80^{\circ}$ . In each of the scales the intervals between the two points are equally divided—in the Centigrade into 100 parts, in the Fahrenheit into 180—the scale being extended downwards to 0—and in the Reaumur into 80, each division in each scale being called a degree, though neither of the divisions of the thermometric scales have any connection with the divisions of a circle, which are also, it will be remembered, called degrees.

## Absolute Temperature

As will be seen when dealing with air and other gases, it is found that gases expand and contract at a certain definite rate for each degree of rise or fall of temperature, such that at a certain number of degrees below the freezing-point of water, if it could be produced, they would cease to exist, the volume being nil. This point, which is  $273^{\circ}$  below  $0^{\circ}$  on the Centigrade scale, or  $-273^{\circ}$  C., and  $493^{\circ}$  on the Fahrenheit scale below freezing-point, or  $461^{\circ}$  below  $0^{\circ}$ , or  $-461^{\circ}$  F., is known as the absolute zero, and all calculations are made from this point. In dealing with the working of gases, steam, etc., it will very often be necessary to refer to the absolute temperatures, as the expansions and contractions, the passages of heat from point to point, and from surface to surface are controlled by the difference in the absolute temperature. The absolute temperature is found in the two scales by adding 273 for Centigrade and 461 for Fahrenheit, to the readings of the scale. The following formulæ will be useful for converting Centigrade temperatures to Fahrenheit, and Fahrenheit to Centigrade :—

$$F. = 1.8 C. + 32 \qquad C. = \left(\frac{5}{9}\right) F. - 32$$

where C. is the number of degrees Centigrade and F. the number Fahrenheit.

## Measurement of Temperatures

For measurement of the lower temperatures, the mercurial thermometer, made in various forms, is sufficient, but for higher temperatures than  $500^{\circ}$  F., special forms of apparatus have to be employed, and in boiler work temperatures as high as  $3000^{\circ}$  F. may have to be measured. The mercurial thermometer made for ordinary domestic use is rarely arranged to read temperatures above  $120^{\circ}$ . It is only used for indicating the temperature of the air of rooms, or of water for baths. For Turkish baths and for the temperatures of boiling water under ordinary atmospheric pressure, the Fahrenheit, or preferably the Centigrade thermometer, graduated to a few degrees above boiling-point, answer all purposes. For higher temperatures again, up to  $500^{\circ}$  F., the Centigrade thermometer having a scale graduated up to  $500^{\circ}$  will answer the purpose. But mercury boils at  $676^{\circ}$  C., and at temperatures over  $500^{\circ}$  C. it is unsuitable for measurements, unless special arrangements are made. It can still be employed for temperatures up to  $800^{\circ}$  F. by the employment of a simple device, the utility of which will be recognized from what is said later in the book, about boiling-points and pressures to which the surfaces of the liquids are exposed. For the higher temperature mercurial

thermometer, a certain quantity of nitrogen gas is included in the tube above the mercury. Nitrogen, it will be remembered, has no chemical effect upon mercury. As the mercury rises, when expanding in the presence of heat, the rising column compresses the nitrogen gas above it, and producing thereby a gradually increasing pressure upon the surface of the mercury, raises the boiling-point of the latter, and so enables mercury to be employed up to 800° F. After 800° F. there are three methods that may be employed—the melting-points of different substances, the expansion pyrometer, and the thermo-electric pyrometer. In the following table the melting-points of different substances employed in the measurement of temperatures is given, and makers of thermometric and pyrometric apparatus supply sets of the substances, arranged in convenient forms for placing in the path of the gases or air, or in the space whose temperature is to be measured.

TABLE I.

APPROXIMATE MELTING-POINTS OF METALS (STIRLING BOILER CO.).

Wrought iron melts at about	. . . . .	2825° Fahr.
Steel (low carbon)	„ . . . . .	2600° „
„ (high carbon)	„ . . . . .	2400° „
Cast iron (white)	„ . . . . .	2200° „
„ (grey)	„ . . . . .	2000° „
Copper	„ . . . . .	1975° „
Gun-metal	„ . . . . .	1700° „
Zinc	„ . . . . .	764° „
Antimony	„ . . . . .	940° „
Lead	„ . . . . .	618° „
Bismuth	„ . . . . .	514° „
Tin	„ . . . . .	447° „
Platinum	„ . . . . .	3230° „
Gold	„ . . . . .	2056° „
Silver	„ . . . . .	1788° „
Aluminium	„ . . . . .	1172° „

## The Expansion Pyrometer

The expansion pyrometer depends upon the unequal expansion of brass and iron, that is referred to in dealing with the expansion of different substances in the presence of heat. The expansion of brass is approximately 50 per cent. greater than that of iron, the coefficients of linear expansion being for iron, from 0.00000556 to 0.00000648, and for brass, from 0.00000957 to 0.00001052. With low temperatures, though the difference in the rate of expansion of the two metals sometimes leads to inconvenience, the difference in any small length of the two is not great, but with high temperatures of 1500° F. and above, the difference is considerable, and this fact is taken advantage of in the construction of the expansion pyrometer. The apparatus consists

of an iron pipe closed at one end, and having a brass rod held inside the pipe, and fixed at the closed end. The other end of the brass rod is free to move, and is connected to multiplying gear, actuating a pointer moving over a dial, so that the difference in the expansion of the brass and iron, which measures the increase of temperature, is read off on the graduated dial, the dial being carefully calibrated for the purpose. The apparatus is not very much used, as it requires considerable skill, and is somewhat sluggish in action, and further, because the early indications obtained from it, with the first changes of temperature, are in the reverse direction to the changes of heat actually taking place, this being due to the fact that the iron pipe shields the brass rod to a certain extent—the air space between it and the brass rod being a bad conductor, the iron pipe becomes heated more quickly than the brass; and on the other hand, it cools more quickly than the brass rod when the temperature is falling, for the same reason, its surface being directly exposed to radiation.

### Thermo-electric Pyrometers

The thermo-electric pyrometer is rapidly taking the place of all others, for the measurement of all ranges of temperature, except those that are conveniently measured by the mercurial thermometer, and for which no particular accuracy is required. The apparatus is made in various forms, some depending on the principle that the electrical resistance offered by a given length of wire of a particular metal, increases in a definite ratio with every degree of increase of temperature; and others upon thermo-electricity. For the resistance apparatus, the metal usually employed is platinum, occasionally platinum alloyed with iridium, or one of the more refractory metals. It will be understood that whatever the apparatus employed is, it must itself be able to withstand the highest temperatures it is required to measure, without changing its physical condition in such a manner as to vitiate the measurements. A short length of a fine platinum or platinum-iridium wire is held in a convenient receptacle of highly refractory material, such as porcelain that has been fired at a very high temperature. The ends of the platinum wire are connected, outside of the heat zone, to copper wires leading to the electrical measuring apparatus. The measuring apparatus is usually arranged in the form of a dial, upon which the temperatures are read off directly, a pointer moving over the dial. The dial is really a galvanometer, forming part of an electric circuit, in which is included a battery of known pressure and resistance. The instrument is calibrated at a certain standard temperature, say 32° F., the temperature of melting ice. As the temperature to which the platinum wire is exposed increases, the resistance of the platinum wire also increases, and the

## 8 STEAM BOILERS, ENGINES, AND TURBINES

strength of the current passing in the electric circuit and through the coils of the galvanometer decreases, the pointer on the galvanometer

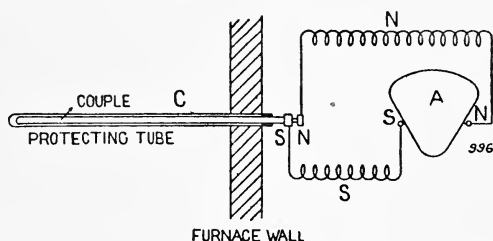

FIG. 1.—Diagram of the Connections of Crompton's Thermo-Electric Pyrometer. C is a Tube protecting the Thermo Couple of Nickel and Steel, a Nickel Rod being inside a Steel Tube, but not touching it. The two are connected together at the fire end and their ends connected to the Circuit, at the other end. N, N, N and S, S, S are connecting wires. A is the galvanometer.

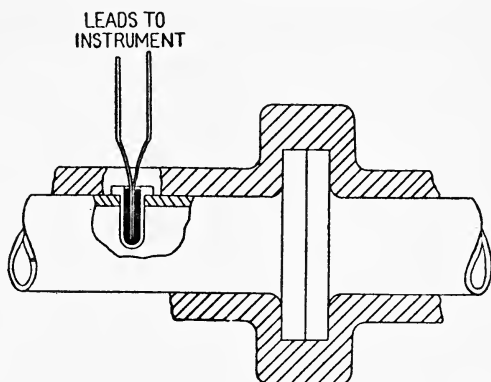

FIG. 2.—Crompton's Thermo-Electric Pyrometer arranged to be inserted in a Pocket in a Steam Pipe, to take the Temperature of the Steam in the Pipe.

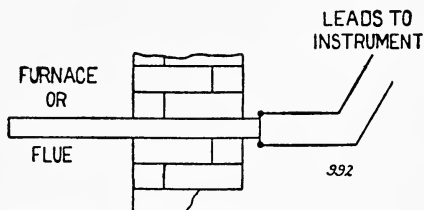

FIG. 3.—The arrangement of Crompton's Thermo-Electric Pyrometer for taking the Temperature of a Furnace or Flue.

moving over the dial in unison with the decrease of current passing through its coils, and the increase of temperature. Convenient points



are taken, say at  $212^{\circ}$ ,  $300^{\circ}$ ,  $400^{\circ}$  and so on, up to the highest temperature the apparatus is intended to measure. In the thermo-electric apparatus a thermo-electric couple takes the place of the resistance wire, one junction being in the refractory tube, and the other outside. The difference of electrical pressure created in the couple furnishes

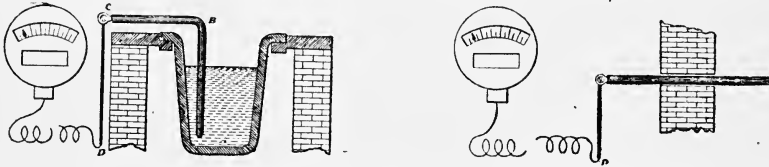

FIG. 4.—Bristol's Thermo-Electric Pyrometer as arranged for taking the Temperature of a Bath of Metal, or a Furnace or Flue.

the indications of temperature, which are read off on a sensitive voltmeter. Fig. 1 is a diagram of the connections of Crompton's thermo-electric pyrometer. Fig. 2 shows the apparatus arranged to take the temperature in a steam pipe, and Fig. 3 that for a furnace or flue. Fig. 4 shows the Bristol thermo-electric pyrometer.

## Entropy

The term "entropy" has only been introduced within recent years, and is not often used at the present time in calculations, except in scientific papers and articles. The author's view is that the measurement of heat and its operation has not sufficiently advanced to enable much use to be made of entropy. There is no law in connection with the measurement of heat similar to Ohm's law in electricity. Entropy, as the author understands it, is the second factor required to make up the energy expended, transmitted, or transformed, in any heat operation. The measurement of any form of energy requires two factors. A weight suspended at a height above the ground is possessed of potential energy, in virtue of its own weight and its height above the ground, and the kinetic energy, the work it will perform in falling to the ground, is the product of those two quantities. Similarly in electricity, the energy that a given generator will transmit is measured by the product of the current it is capable of furnishing, multiplied by the pressure at which the current is delivered to the cables employed in transmitting it. Similarly, it appears to the author, the energy involved in any operation where heat is employed is measured by the two quantities, temperature which is, as explained, virtually the pressure, and entropy.

## Transmission of Heat

It is usual to say that heat is transmitted by three processes, radiation, conduction, and convection. To the author's mind the

three are really different forms of the same thing—conduction, modified by the conditions under which the heat is being transmitted. Whenever any body is at a higher temperature than surrounding bodies, it attempts to deliver a portion of its heat to the surrounding bodies, and will continue to do so until their temperature is the same as its own, their temperature being raised, and its temperature being lowered in the process. It follows that a heated body suspended, say in air, sends out heat-waves in all directions, and this is what is known as radiation, a “ray” which was dealt with when explaining refraction and reflection, being a pencil consisting of a minute portion of a succession of waves, the ray extending in a straight line from the heated body. Conduction is known as the process by which heat is conveyed from a body, or a portion of a body, at a higher temperature, to the substances immediately in contact with it. The illustration usually given is that of a poker having one end in a fire. The end in the fire becomes heated, and transmits its heat from that portion in the fire to that next outside, this portion transmitting its heat in its turn to the portion next outside of it, and so on, the heat travelling through the length of the poker, and if time be given, the outer end of the poker becoming very hot, the heat in this case being transmitted through the successive portions of the poker by contact. Conduction also takes place from any heated body, such as a steam-pipe, or the outside of the cylinder of a steam-engine, to the air that is in contact with it, but the molecules of air being free to move among themselves, and being expanded when heat is delivered to them, tend to move away from the heated surface, under the forces of expansion, and the pressure of the colder molecules of air surrounding them, the result being that a fresh quantity of air reaches the heated surface, is heated and expanded in its turn, moves away, and gives place to another body of air, and so on. Practically the same action takes place with water, and is known as convection. It is the method by which heat is distributed in rooms and places where the air is in motion, and in boilers and other vessels where water or other liquids are being heated. It will be seen, however, that the process of convection is really conduction, with the subsequent action, caused by the expansion of the gas or water in contact with the heated body.

Air and gases are bad conductors of heat; the metals are all good conductors; and it is sometimes said that air is transparent to what is known as radiant heat. By radiant heat the author understands the heat-waves which pass outwards, or radiate, from a heated body, and as he understands the matter, air, nitrogen and oxygen are apparently transparent to the heat-waves, because they are very deficient in another property, viz. that of absorption of heat. All substances absorb heat when heat-waves are delivered to them, but

in very different ratios, and the gases of which air is composed have especially low absorbing values. According to the late Professor Tyndal, carbonic oxide and carbonic acid have absorbing values at the ordinary atmospheric pressure ninety times as great as that of either air, oxygen, or nitrogen. All substances vary in their ability to conduct heat in the sense given above, as illustrated by the heated poker. The metals are the best conductors, silver being the best of the metals, and copper standing very high. The following table gives the relative thermal conductivities of different metals.

TABLE II.

TABLE OF RELATIVE CONDUCTIVE POWERS OF METAL EMPLOYED IN STEAM APPARATUS, SILVER BEING TAKEN AS THE STANDARD.

Silver.	. 100.0	Zinc . . .	19.9	Steel . . .	12.0
Copper . .	77.6	Tin . . .	14.5	Lead . . .	8.5
Brass . . .	33.0	Iron . . .	17.0	Platinum . .	8.2

As in electricity, the substances naturally divide into thermal conductors and thermal insulators, the former being employed when it is required to transmit heat freely, as in the case of boiler-tubes and boiler-flues, where conduction is required from the hot gases to the water; the latter being employed when it is desired to prevent the escape of heat, as in the substances with which steam-pipes and boilers are covered. The following is a table of thermal insulators. The table given in this case is based on the number of B. Th. units transmitted per square foot of surface per hour exposed, with the insulating material 1 inch in thickness, for each 1° F. difference of temperature.

TABLE III. (LORENZ).

Plaster (ordinary) . . .	2.67	Quartz sand in powder . . .	2.18
„ (very fine) . . .	4.2	Brick dust. . . . .	1.12-1.33
Brick . . . . .	4.11-5.56	Chalk in powder . . .	0.694-0.870
Wood, fir (transmission perpendicular to fibres) . . .	0.75	Wood ashes . . . . .	0.484
Wood, fir (transmission parallel to fibres) . . .	1.37	Sawdust, mahogany . . .	0.524
Wood, oak (transmission perpendicular to fibres) . . .	1.70	Charcoal powdered . . .	0.637
Cork . . . . .	1.15	Coke powdered. . . . .	1.29
Indiarubber . . . . .	1.37	New calico . . . . .	0.403
Gutta percha . . . . .	1.39	Cotton or sheep's wool . . .	0.323
Glass . . . . .	6.05-7.10	Eider down . . . . .	0.315
		Mineral wool . . . . .	0.38-0.47
		Hair felt . . . . .	0.40

Thermal conductivity is defined by scientists as the ratio of rate of transmission of heat, through the substance in question, to the temperature gradient. The rate of transmission is proportional to the temperature gradient, and is the quantity of heat transmitted in unit time, through unit area of cross section of the substance, the

unit cross section being perpendicular to the lines of flow of the heat. By the temperature gradient is meant the gradual fall of temperature between the two surfaces, one of which is at a higher temperature than the other. The following formula is given for the rate of transmission of heat :—

$$\text{Rate of transmission } \frac{Q}{AT} = k(\theta' - \theta'')x$$

where  $Q$  is the quantity of heat transmitted through the sectional area  $A$  in time  $T$ , and  $k$  is the conductivity,  $x$  the thickness of the substance, and  $\theta' - \theta''$  the temperature gradient. For practical purposes the rate of transmission of heat between any two surfaces may be taken to be proportional to the difference of temperature between the two surfaces, to the area of the surfaces, and to the thermal conductivity of the substances interposed between them, or inversely to the thermal resistance of the interposed substance.

### Thermal Conductivity of Finely Divided Substances

It had better be noted here that the thermal conductivity of any substance, in a finely divided state, is very low. The reason is, as the author understands the matter, when the substance is in a finely divided state, as in a fine powder with its particles loosely in contact with each other, there are a very large number of minute air spaces between the particles, and the heat current, in passing through the substance, has to pass across these minute air passages, which offer a very high thermal resistance, providing that moisture is not present. Dry air, when absolutely motionless, is one of the best thermal insulators. It offers a very high thermal resistance. In addition to this, the resistance offered by a loose agglomeration of minute bodies to the passage of heat or electricity is always high, because there is always a resistance set up when any physical force passes from one substance to another. In electricity, what is known as contact resistance is always high, and the same thing rules in the transmission of heat.

The above is of particular importance in connection with steam-boilers and their accessories, because the finely divided particles of carbon, which are built up on the surfaces of flues, or on the surfaces of the tubes of water-tube boilers, and of economizers, and on the inside of chimneys, reduce the efficiencies of those apparatus. On the other hand, the property mentioned is of great value, where it can be applied, to prevent the egress of heat, say from steam-pipes, the surfaces of steam-boilers, etc. Many of the substances that are sold for insulating steam-pipes and steam-boilers, such as silicate

cotton, finely divided charcoal, and others, owe their thermal insulating value to these properties. The property occurs in another form, but with equal value, where it can be employed, in cork. Cork is built up of a number of very minute air cells, each enclosed in a fine membrane, and any heat passing through a mass of cork has to pass through the air-cells, and, as mentioned above, to pass in succession from the membrane to the air, from the air to the membrane again, and so on.

## Specific Heat

Specific heat is the ratio between the quantity of heat required to raise the temperature of 1 lb. of any substance  $1^{\circ}$  F., compared with that required to raise the temperature of 1 lb. of water at  $39^{\circ}$  F. to  $40^{\circ}$  F.,  $39^{\circ}$  F. being the greatest density of water.

**The British Thermal Unit.**—The specific heat of water is taken as 1, and what is known as the heat unit, or the B. Th. unit, is the quantity of heat required to raise the temperature of 1 lb. of water from  $39^{\circ}$  F. to  $40^{\circ}$  F. The table gives a list of the specific heats of a number of substances.

TABLE IV.

SPECIFIC HEATS OF VARIOUS SUBSTANCES (STIRLING BOILER Co.).

<i>Solids.</i>	
Copper . . . . .	0.0951
Gold . . . . .	0.0324
Wrought iron . . . . .	0.1138
Cast iron . . . . .	0.1298
Steel (soft) . . . . .	0.1165
„ (hard) . . . . .	0.1175
Zinc . . . . .	0.0956
Brass . . . . .	0.0939
Glass . . . . .	0.1937
Lead . . . . .	0.0314
Platinum . . . . .	0.0324
Silver . . . . .	0.0570
Tin . . . . .	0.0562
Ice . . . . .	0.5040
Sulphur . . . . .	0.2026
Charcoal . . . . .	0.2410
<i>Liquids.</i>	
Water . . . . .	1.0000
Alcohol . . . . .	0.7000
Mercury . . . . .	0.0333
Benzine . . . . .	0.4500
Glycerine . . . . .	0.5550
Lead (melted) . . . . .	0.0402
Sulphur (melted) . . . . .	0.2340
Tin (melted) . . . . .	0.0637
Sulphuric acid . . . . .	0.3350
Oil of turpentine . . . . .	0.4260

*Gases.*

	At constant pressure.	At constant volume.
Air (at freezing-point) . . . . .	0·2375	0·1685
Oxygen . . . . .	0·2175	0·1551
Nitrogen . . . . .	0·2438	0·1727
Hydrogen . . . . .	3·4090	2·4123
Superheated steam * . . . . .	0·4805	0·346
Carbon monoxide (CO) . . . . .	0·2479	0·1758
„ dioxide (CO <sub>2</sub> ) . . . . .	0·2170	0·1535
Olefiant gas . . . . .	0·4040	0·173
Blast-furnace gas . . . . .	0·2277	
Chimney gases (approx.) . . . . .	0·240	

The absolute unit of heat is the calorie. It is the unit based upon the centimeter-gramme-second system of units, and is the quantity of heat required to raise the temperature of 1 gramme of water from 4° C. to 5° C., and is equal to 0·00396 British Thermal Units. The British Thermal Unit is usually written B. Th. U.

In France and on the Continent, where the centimeter-gramme-second system is employed, another unit, the great calorie, is used. This is the quantity of heat required to raise 1 kilogramme (1000 grammes) = 2·2 lbs. of water from 4° C. to 5° C. The great calorie is = 3·968 B. Th. units.

The specific heat of most substances varies with the temperature, that of water increasing with the temperature; the specific heat of water increases from 1·0 at the point of greatest density, to 1·013 at 212° F., and to 1·0364 at 356° F., and 1·0568 at 446° F. But for all practical purposes the specific heat of water is taken as unity, throughout the range of temperature employed in boiler work. The following table gives the specific heats of the principal substances employed in connection with steam:—

TABLE V.

Aluminium . . . . .	0·2181	Coal (bituminous) . . . . .	0·2777
Antimony . . . . .	0·0508	„ (anthracite) . . . . .	0·2017
Brass . . . . .	0·0939	Glass . . . . .	0·1977
Copper . . . . .	0·0951	Olive oil . . . . .	0·3096
Iron (cast) . . . . .	0·1298	Air . . . . .	0·2669
„ (wrought) . . . . .	0·1138	Oxygen . . . . .	0·2361
Lead . . . . .	0·0314	Hydrogen . . . . .	3·2936
Nickel . . . . .	0·1086	Nitrogen . . . . .	0·2754
Steel . . . . .	0·1165	Carbonic acid . . . . .	0·2210
Tin . . . . .	0·0562	„ oxide . . . . .	0·2884
Zinc . . . . .	0·0955	Wood (oak) . . . . .	0·570
Brickwork . . . . .	0·20	„ (fir) . . . . .	0·650
Limestone . . . . .	0·2174		

\* The specific heat of superheated steam is variable.

## The Mechanical Equivalent of Heat

The first law of thermo-dynamics states that heat and mechanical work are interchangeable, and the classical experiments of Joule, confirmed later by numerous other experimenters, has shown that the B. Th. unit has a definite mechanical equivalent. That is to say, the energy present in, or delivered by, 1 B. Th. unit, has its definite equivalent in mechanical energy. Joule made the equivalent 772 foot lbs., but later experimenters—Rowland of Baltimore in particular—have made it 778 foot lbs., and the latter figure is that which is taken for calculation at the present time. The meaning of the mechanical equivalent of heat is, that when heat is delivered to water, in the process of converting it into steam, or is delivered to steam to raise it to a higher temperature, the ability is conferred upon the steam of performing mechanical work, just as the ability is conferred upon a weight of performing work, by raising it above the surface of the earth, and the work done by steam in cooling, is directly proportional to the heat it loses in the process, as measured by the mechanical equivalent.

## The Rate of doing Work

The unit of mechanical work is the foot lb., the work that 1 lb. will perform in falling to earth from a height of 1 foot, or any equivalent of this, such as the work that 2 lbs. will perform in falling from a height of 6 inches,  $\frac{1}{2}$  lb. in falling from a height of 2 ft., and so on. When work is performed at the rate of 33,000 foot lbs. per minute, or 550 foot lbs. per second, it is said to be at the rate of 1 H.P., that is to say, the engine that is able to do work at this rate is supposed to be working at the rate at which a horse would work, in drawing a load, or in any other way. The 33,000 foot lbs., or the 550 foot lbs. may be in any form in which the two factors, the weight and the distance through which it falls, will make up these figures when multiplied together. Thus a weight of 55 lbs. falling through a vertical distance of 10 ft. in 1 second, performs work at the rate of 1 H.P., and similarly  $5\frac{1}{2}$  lbs. falling through 100 ft. performs work at the same rate.

The B. Th. unit, it will be seen, is directly connected with the H.P. from the fact that it requires the expenditure of  $33,000 \div 778 = 42.4$  B. Th. units per minute to perform work at the rate of 1 H.P., on the supposition that the whole of the energy of the heat is converted into useful mechanical work. As will be seen later in the book, the whole of the heat energy delivered to the steam is never converted into useful mechanical work. There are several charges for conversion, etc., on the way.

## Expansion of Bodies in the Presence of Heat

Nearly all substances expand with increased temperature, in a certain definite ratio, with each degree of increase. The ratio is known as the coefficient of expansion. The coefficients of expansion of different substances are given in the following table:—

TABLE VI.

	Expansion per 1° F.	Expansion per 1° C.
Aluminium . . . . .	0·00001234	0·00002221
Brass . . . . .	0·00000957 to 0·00001052	0·00001722 to 0·00001894
Copper . . . . .	0·00000887	0·00001596
Iron (cast) . . . . .	0·00000556	0·00001001
„ (wrought) . . . . .	0·00000626 to 0·00000648	0·00001126 to 0·00001166
Steel . . . . .	0·00000636 to 0·00000689	0·00001144 to 0·00001240
Lead . . . . .	0·00001571	0·00002828
Platinum . . . . .	0·00000479	0·00000863
Tin . . . . .	0·00001163	0·00002094
Zinc . . . . .	0·00001407	0·00002532
Cement . . . . .	0·00000594 to 0·00000797	0·00001070 to 0·00001435
Concrete. . . . .	0·00000795	0·00001430
Glass . . . . .	0·00000397 to 0·00000499	0·00000714 to 0·00000897
Granite . . . . .	0·00000438 to 0·00000498	0·00000789 to 0·00000897
Brickwork . . . . .	0·00000256 to 0·00000494	0·00000460 to 0·00000890
Porcelain . . . . .	0·00000200	0·00000360
Slate . . . . .	0·00000577	0·00001038
Sandstone . . . . .	0·00000494 to 0·00000652	0·00000750 to 0·00001174
Wood (pine) . . . . .	0·00000276	0·00000496

Water also expands from the point of greatest density to the freezing-point, and also with increasing temperature, the relative volumes being at 212° F. 1·0466, at 300° 1·09563, at 400° 1·15056, and at 500° 1·2205, the volume at the point of greatest density being taken as unity. All liquids expand in different ratios.

Nearly all substances also contract on cooling, and this is the property that enables metals to be cast in different patterns. A few substances, such as bismuth, expand on cooling, and these are available for certain work. Water expands when frozen. One important point in connection with the expansion of different substances, is the relative rates at which different substances expand with the same increase of temperature. Where two metals, for instance, are employed together in a piece of machinery, and are exposed to heat, if they expand at different rates, the result may sometimes be serious; cracks, for instance, being formed in vessels containing hot substances, or explosive gases, leaks being caused in valves, etc.

## Latent Heat

A great many substances, experiment does not enable us to say whether all substances, may exist in one of three states—the solid, the



liquid, or the gaseous. In the solid state the molecules of the substance are very close together, and are not easily moved upon each other, force being required to separate them, the force varying with the substance; metals, and particularly iron and steel, requiring the largest expenditure of force to rend them. In the liquid state the molecules are also close together, though not as close as in the solid state, but they are able to move freely over each other, and require the expenditure of very little force to cause them to do so. In the gaseous state the molecules, according to the latest modern views, are very much more widely separated than in either the liquid or the solid state, and they are in constant motion. Gases and liquids are both called "fluids" in scientific language, many properties being common to both of them. The main difference between the solid, the liquid, and the gaseous state is the presence or absence of a certain quantity of heat. With a great many substances, if heat be applied to a body of the substance in the solid condition, its temperature will rise, and in many cases it will soften, as the heat is delivered to it; but at a certain temperature it will commence to pass into the liquid condition, the temperature remaining constant, till the whole of the substance to which the heat is being delivered, has become liquid. If heat is still applied, the temperature of the liquid will again increase, the liquid expanding, as explained in a previous paragraph, until at another certain temperature the liquid will commence to pass into the gaseous condition, the temperature again remaining constant until all the liquid has become gas. The most striking instance of this, and the one that is of most importance in connection with steam, is that of water. Water exists in the solid state as ice, in the liquid state as water, and may be made to exist in the gaseous state as steam. In the neighbourhood of the poles, it exists principally as ice. In the tropics and in the temperate zones, it exists principally as water, but it may be made to exist as steam, and it exists largely as vapour in all latitudes. If a block of ice weighing say 1 lb. be heated, it will be found that the temperature of the ice, which is usually below freezing-point if the ice is stable, will gradually rise to  $32^{\circ}$  F. or  $0^{\circ}$  C., and at that point the ice will begin to form water, and if a thermometer be placed in the melting mass, it should remain constant, at freezing-point, until the whole of the ice has become water. If a measurement of the quantity of heat delivered to the melting ice be taken, it will be found to be exactly 142.4 B. Th. units for 1 lb. of pure water ice melting to water. If heat is applied to the water, its temperature will rise steadily, until at  $212^{\circ}$  F. or  $100^{\circ}$  C., at standard barometric pressures and at sea-level, the water will commence to pass into the form of steam, and the temperature again will remain at  $212^{\circ}$  F., until all the water has become steam. If the quantity of heat again be measured, it will be found that 966 B. Th. units have

been absorbed in converting the 1 lb. of water at  $212^{\circ}$  into 1 lb. of steam. The heat required to convert 1 lb. of water into steam is called the *latent* heat of steam, and the quantity of heat required to convert 1 lb. of ice at  $32^{\circ}$  F. into water, is the *latent* heat of water, though the expression is not often used.

## The Variation of the Boiling-point

The boiling-point of every liquid, the temperature at which it will commence to pass from the liquid to the gaseous condition, varies with the pressure to which the surface of the liquid is exposed. For standard calculations, the standard atmospheric pressure is taken, this being 760 mm. or 29.962 inches at sea-level. Our earth, it will be remembered, is surrounded by an envelope of what we call atmospheric air, extending from the surface to a considerable height.

The atmosphere contains what we call air, consisting principally of the two gases, oxygen and hydrogen, and it also contains quantities of the vapour of water—as will be described more fully in dealing with air—and other substances, such as dust that rises from the earth, meteoric dust, the vapours of different substances that arise from the earth, particularly in manufacturing districts. The air and the other substances all have weight; a cubic foot of air at the standard atmospheric pressure, and at  $32^{\circ}$  F., weighs 0.08 of a lb.

The average weight of the column of air supported upon a surface of the earth 1 square inch in area is taken to be 14.7 lbs. The weight of the column of air above the earth's surface is known as the atmospheric pressure; 14.7 lbs. per square inch, is referred to as a pressure of one atmosphere. The atmospheric pressure is usually measured by the column of mercury that it will support, in the ordinary vertical mercurial barometer. The ordinary vertical mercurial barometer, which is familiar to every one, consists of a vertical tube, closed at the top, in which a quantity of mercury is placed, the lower end of the tube dipping into a vessel also containing mercury, and open to the atmosphere. The pressure of the atmosphere upon the mercury in the open vessel forces that in the tube upwards, and the height of the mercury in the barometric tube indicates from hour to hour the variation in the pressure of the atmosphere or in its weight. A glance at any barometric chart, such as those that are printed in the columns of the *Times* and other papers, will show that at any particular place the barometric pressure varies from day to day, often by large amounts on successive days, and even within a few hours. It also varies from place to place, this

variation being one cause of the winds which blow over different countries. The variation in the pressure of the atmosphere at any point on the surface is due to the variation in the weight of the atmosphere above that point, this being due again largely to the variation in the quantity of the vapour of the water present there. Every one is familiar with the saying, that when the glass—the barometer—is going down we shall probably have rain, and *vice versá*. When the indications of the barometer are low, it is due to the weight of the atmosphere at the point where the barometer is fixed being less than the normal, this again being due to the displacement of a certain portion of the air above by a certain quantity of the vapour of water, the vapour of water weighing considerably less than the air it displaces. Air and whatever it holds in suspension, being fluid, has one of the important properties of all fluids, it transmits pressures in all directions, wherever it is present. Thus we are all familiar with the fact that though we are subject to the average pressure of 14·7 lbs. per square inch, at every part of our bodies, and even of parts of our internal organisms, such as our lungs, and that if the total pressure on our bodies was summed up it would be somewhat considerable; yet we are absolutely unconscious of the fact, because, owing to the equal transmission of pressure everywhere, by the fluid air and whatever it may have absorbed the pressure is equal everywhere. Hence, in any vessel in which water is contained, for the purpose of being boiled, the pressure of the air, whatever it may be at the moment, is present at every part of the surface of the water, and in order that the water may boil, that is that it may throw out gas into the atmosphere, it must become possessed of sufficient energy, or rather must deliver sufficient pressure to the vapour it is throwing off, to overcome the pressure of the atmosphere. The operation of boiling, in fact, in the case of any liquid, consists of the formation of a gas, and the delivery to that gas at a pressure sufficient to enable it to escape into the atmosphere, notwithstanding the pressure exerted by the atmosphere upon the surface of the liquid from which the gas is escaping. The matter may be put in another way. All liquids evaporate at all temperatures, and this is particularly true of water. The vapour which is coming away from the surface of the liquid, exerts a certain pressure upon the atmosphere into which it is escaping, and when this pressure is equal to that of the atmosphere, the liquid becomes a gas very freely, and is said to boil. It will easily be understood from the above, that an increase or decrease of pressure on the surface of the liquid changes the temperature at which boiling takes place. It is a well known fact that water boils at a lower temperature on mountain tops, owing to the lower pressure of the atmosphere there.

The standard boiling-point of water is taken as 212° at sea-level,

with the barometer constant at 29·962. At the first floor of the Paris Observatory, which is 213 feet above sea-level, the standard barometric pressure is 29·69, and the boiling-point of water 211·5° F. At Moscow, at a height of 984 feet above sea-level, the standard barometric pressure is 28·82, and the boiling-point of water 210·2°. At Madrid, which is 1995 feet above sea-level, the standard barometric pressure is 27·72, and the boiling-point of water 208°. At the Hospice of St. Gothard, 6808 feet above sea-level, the standard barometric pressure is 23·07, boiling-point of water 199·2°. At Quito, in Peru, 9541 feet above sea-level, standard barometric pressure is 20·75, boiling-point of water 194·2°. Table VII. gives the boiling-points at different

TABLE VII.  
BOILING-POINT OF WATER AT VARIOUS ALTITUDES.

Boiling-point in degrees. Fahrenheit.	Altitude above sea-level. Feet.	Atmospheric pres- sure. Pounds per square inch.	Barometer. Inches.
184	15,221	8·19	16·79
185	14,649	8·37	17·16
186	14,075	8·56	17·54
187	13,498	8·75	17·93
188	12,934	8·94	18·32
189	12,367	9·13	18·72
190	11,799	9·33	19·13
191	11,243	9·53	19·54
192	10,685	9·74	19·96
193	10,127	9·95	20·39
194	9,579	10·16	20·82
195	9,031	10·38	21·26
196	8,481	10·60	21·71
197	7,932	10·82	22·17
198	7,381	11·05	22·64
199	6,843	11·28	23·11
200	6,304	11·52	23·59
201	5,764	11·76	24·08
202	5,225	12·01	24·58
203	4,697	12·25	25·08
204	4,169	12·51	25·59
205	3,642	12·77	26·11
206	3,115	13·03	26·64
207	2,589	13·29	27·18
208	2,063	13·57	27·73
209	1,539	13·84	28·29
210	1,025	14·12	28·85
211	512	14·41	29·42
212	Sea-level.	14·70	30·00

heights above sea-level. It may be noted incidentally that mountain sickness is largely due to the decreased atmospheric pressure; the

lungs and the stomach, which, it will be remembered, work together in the process of respiration, requiring some time to accommodate themselves to the lowered pressure at considerable heights.

On the other hand, an increased pressure raises the boiling temperature. From the table of properties of saturated steam that is given on p. 24, it will be seen that while the boiling-point with 14·7 lbs. pressure is 212° F., with 50 lbs. pressure it is 281°, with 80 lbs. pressure it is 312°, with 120 lbs. pressure it is 341°, and with 200 lbs. pressure 382°, while with lower pressures, such as are obtained when engines are working on a condenser with 10 lbs. pressure, the boiling-point is 193°, with 5 lbs. it is 162°, and with 1 lb. it is 102°.

## The Influence of Dissolved Substances upon the Boiling-point of Water.

Water, as is explained later, dissolves a very large number of substances, liquid, solid, and gaseous, and the act of solution changes the temperature of the boiling-points and of the freezing-points. Brine made with a solution of common salt, and of calcium chloride, is used with refrigerating apparatus, because it does not freeze at ordinary temperatures, and can be kept in circulation at practically any low temperature that may be desired, for cold stores, or for ice-making plant. On the other hand, the presence of salts in solution raises the boiling temperature. The increase has been measured for a large number of substances. Common salt is one of the substances of which the largest number of measurements have been taken, as it is, or it would be more correct to say was, so commonly employed in the boilers of steam ships. Three per cent. of salt raises the boiling point to 213·2° F., at standard atmospheric pressure; 6 per cent. raises it to 214·4° F.; 9 per cent. to 215·5° F.; 12 per cent. to 216·7° F.; and approximately it may be taken that each 3 per cent. of salt increases the boiling-point 1° F. Other substances, such as chloride of calcium, nitrate of soda, nitrate of ammonia, carbonate of soda, chloride of potassium, also raise the boiling-point in various proportions.

It should be noted that while the boiling-point of the solution is raised, the steam which is formed from the solution is of pure water, though it may contain minute portions of the salt, held in mechanical suspension. Bodies held in mechanical suspension in water, do not affect its boiling-point. Thus the finely divided substances that are taken up by water in its course over rocks, etc.,

have no effect upon the temperature at which the water holding it will boil.

### Absolute Pressure

The pressures given in the last paragraph are termed "absolute pressures," the pressure above zero. In the ordinary steam working, the steam gauge indicates pressure above the atmosphere, and in order to obtain figures for absolute pressure, it is necessary to add to the gauge pressure 14·7 lbs. Absolute pressures are usually employed in calculations, and the two pressures are distinguished, when talking or writing, by the names "absolute" and "gauge" pressures.

### Variation of the Latent Heat with Variation of Pressure

It has been explained above that the boiling-point varies with the pressure. It will be understood that immediately steam commences to be formed, in a closed vessel, such as a boiler, the pressure increases, and with it the temperature at which the water will form steam. In practice steam is allowed to continue to be formed, until the pressure reaches that with which the engines, turbines, etc., are working, and in good practice it is maintained approximately at this pressure, so long as the plant is working. Any increase of pressure however caused, say, by engines not taking steam for a time, increases the temperature at which the steam will be formed, and *vice versâ*. It will be understood, of course, that in any boiler in which steam is being formed, the temperature of the water and of the steam being formed from it, are the same, or at least that portion of the water that is directly in contact with the steam, and from which the steam is issuing. In addition to the temperature at which steam is formed increasing and decreasing with the rise and fall of pressure, the latent heat also changes, but inversely. As the pressure rises, the temperature rises, and the latent heat falls, and *vice versâ*. The matter may be looked upon in the following manner. Taking water at average temperature, say 60°, a certain quantity of heat is required to raise it to boiling-point. With standard pressure, 14·7 lbs. per square inch, 152 B. Th. units are required to raise every pound of water to boiling temperature, and 966 units are required to convert the pound of water into steam at the same temperature. With a pressure of 50 lbs. per square inch absolute, the boiling temperature being

281° F., 221 B. Th. units are required to raise the water to boiling temperature, but only 916·3 units are required to convert it into steam at that temperature, and so on with higher pressures. On the other hand, with lower pressures, such as are obtained by condensation of the exhaust steam from engines and turbines, the latent heat of the steam, the quantity of heat retained by the steam, as long as it remains steam, steadily increases. At 10 lbs. absolute pressure the latent heat has risen to 978·4 B. Th. units, at 5 lbs. absolute pressure it has risen to 1000·3 units, and at 1 lb. absolute pressure it is 1042·9 units. It will be seen that this is an important matter, when dealing with the work that is to be obtained from steam engines and steam turbines, because the useful work obtainable depends entirely upon the number of heat units that can be abstracted from the steam in the course of the performance of mechanical work. It should be noted, however, that the total quantity of heat required by each pound of water to raise it to boiling-point, and to convert it into steam at different pressures, steadily increases as the pressure increases. Taking water at 60°, with an absolute pressure of 1 lb. per square inch, 1084 heat units are required to bring it to boiling-point and to convert it into steam. At 10 lbs. absolute pressure the quantity has risen to 1112 units. At standard atmospheric pressure 14·7 lbs. per square inch, it has risen to 1118 units. At 50 lbs. absolute it is 1139 units. At 100 lbs. absolute it is 1153 units; and at 200 lbs. absolute it is 1170. It goes on increasing with higher temperatures and higher pressures up to approximately 466 lbs. per square inch absolute, when the boiling temperature is 460° F., the latent heat being 777·4 B. Th. units, and the total heat delivered to the water to raise its temperature and to convert it into steam from 60° is 1186, according to the experiments of Dr. de Laval. The latent heat of the steam steadily decreases as the pressure increases, but after the critical point is passed, the total quantity of heat required to produce the steam also steadily decreases. Table VIII. gives what are called the properties of saturated steam, the temperatures, corresponding to each pressure, the latent heat, volume of each pound of steam, etc.

TABLE VIII.  
PROPERTIES OF SATURATED STEAM.

Absolute pressure in lb. per sq. in.	Temperature or boiling point in degrees F.	Total heat in thermal units per lb. of steam from 0° F.	Latent heat in thermal units per lb.	Volume (cubic feet per lb.).	Weight of 1 cubic foot of steam in lb.	Cubic feet of steam from 1 cubic foot of water at 62° F.
1	102.0	1145.0	1042.9	330.36	0.0030	20,600
2	126.4	1152.2	1025.8	172.08	0.0058	10,730
4	153.1	1160.1	1006.8	89.62	0.0112	5,589
5	162.3	1163.0	1000.3	72.66	0.0138	4,580
8	183.0	1169.2	985.7	46.69	0.0214	2,911
10	193.3	1172.3	978.4	37.84	0.0264	2,360
12	202.0	1175.0	972.2	31.88	0.0314	1,988
15	213.1	1178.4	964.3	25.85	0.0387	1,611
18	222.5	1181.2	957.7	21.78	0.0459	1,357
20	228.0	1182.9	952.8	19.72	0.0507	1,229
22	233.3	1184.5	949.9	18.03	0.0555	1,123
25	240.5	1186.6	945.3	15.99	0.0625	996
30	250.5	1189.8	937.9	13.46	0.0743	838
35	259.4	1192.5	931.6	11.65	0.0858	726
40	267.0	1194.9	926.0	10.27	0.0974	640
45	274.5	1197.1	920.9	9.18	0.1089	572
50	281.0	1199.1	916.3	8.31	0.1202	518
55	287.1	1201.0	912.0	7.61	0.1314	474
60	292.6	1202.7	908.0	7.01	0.1425	437
65	298.0	1204.3	904.2	6.49	0.1538	405
70	302.8	1205.8	900.8	6.07	0.1648	378
75	307.5	1207.2	897.5	5.68	0.1759	353
80	312.1	1208.5	894.3	5.35	0.1869	333
85	316.1	1209.9	891.4	5.05	0.1980	314
90	320.3	1211.1	888.5	4.79	0.2089	298
95	324.0	1212.3	885.8	4.55	0.2198	283
100	327.7	1213.4	883.1	4.33	0.2307	270
105	331.2	1214.4	880.7	4.14	0.2414	257
110	334.6	1215.5	878.3	3.97	0.2521	247
115	337.9	1216.5	875.9	3.80	0.2628	237
120	341.1	1217.4	873.7	3.65	0.2738	227
125	344.2	1218.4	871.5	3.51	0.2845	219
130	347.2	1219.3	869.4	3.38	0.2955	211
135	350.1	1220.2	867.4	3.27	0.3060	203
140	352.9	1221.0	865.4	3.16	0.3162	197
145	355.6	1221.9	863.5	3.06	0.3273	190
150	358.3	1222.7	861.5	2.96	0.3377	184
155	361.0	1223.5	859.7	2.87	0.3484	179
160	363.4	1224.2	857.9	2.79	0.3590	174
165	366.0	1224.9	856.2	2.71	0.3695	169
170	368.3	1225.7	854.5	2.63	0.3798	164
175	370.8	1226.4	852.9	2.56	0.3899	159
180	373.0	1227.1	851.3	2.49	0.4009	155
185	375.3	1227.8	849.6	2.43	0.4117	151
190	377.5	1228.5	848.0	2.37	0.4222	148
195	379.6	1229.2	846.5	2.31	0.4327	144
200	381.8	1229.8	845.0	2.26	0.4431	141
210	385.8	1231.1	841.9	2.16	0.4634	135



## Air

Atmospheric air is a mixture of gases, principally oxygen and nitrogen, in the proportion approximately of 79 per cent. of nitrogen to 21 per cent. of oxygen. As mentioned in a previous paragraph also, atmospheric air nearly always contains a certain quantity of the vapour of water. Water is always being evaporated from the surfaces of oceans, rivers, and the land, the vapour so formed becoming the clouds we see in temperate and cold regions, the fogs we are unfortunately so familiar with in this country, and later becoming rain, sleet, and snow. Air has very much the same properties with regard to other gases, and to minute particles of solid matter, that water has. As explained above, gases and liquids are both fluids in scientific language, and have a great many properties alike. One property is the ability to absorb other vapours, and solid matter in a finely divided state, also the different bacilli, disease germs, and minute animalcules of all kinds. The quantity of the vapour of water that air can absorb varies with the temperature, but the law is a very peculiar one. It follows a parabolic curve. The percentage of the vapour of water that the air can absorb at low temperatures, is very small, amounting to  $1\frac{1}{4}$  grains per cubic foot at  $20^{\circ}$  F., and it increases very slowly up to a temperature of  $60^{\circ}$  F., when it increases more rapidly. The presence of the vapour of water in air has a very important bearing upon the feeding of the furnaces of steam boilers with air. When watery vapour is present in air, it is there at the expense of a portion of the volume that would otherwise be occupied by the air. Thus if 2 per cent of water is present in a cubic foot of air, it means that the actual quantity of air is only 1692.44 cubic inches, instead of 1728, and that therefore in place of 362.9 cubic inches of oxygen being delivered to the furnace, only 290.3 cubic inches are delivered.

As already explained also, air expands and contracts  $\frac{1}{273}$  of its volume for every degree C., and  $\frac{1}{461}$  for every degree F. This means that as the temperature of the air increases, the quantity of air present, and therefore the quantity of oxygen present, decreases in this proportion, so that when air of, say,  $80^{\circ}$  F. temperature is fed to a boiler furnace, it only delivers 0.01545 lb. weight of oxygen per cubic foot as against 0.01604 lb. weight per cubic foot at  $60^{\circ}$  F., and this is irrespective of the quantity of moisture the air may contain. These figures may seem small, but they become serious, when millions of cubic feet are dealt with. Table IX. gives the weight

TABLE IX.

VOLUME AND WEIGHT OF AIR AT VARIOUS TEMPERATURES, AND ATMOSPHERIC PRESSURE (STIRLING BOILER Co.).

Temperature in degrees Fahrenheit.	Volume of 1 lb. cubic foot.	Weight of 1 cubic foot in pounds.
50	12·840	0·077884
55	12·964	0·077133
60	13·090	0·076400
65	13·216	0·075667
70	13·342	0·074950
75	13·467	0·074260
80	13·593	0·073565
85	13·718	0·072894
90	13·845	0·072230
95	13·970	0·071580
100	14·096	0·070942
110	14·346	0·069698
120	14·598	0·068500
130	14·849	0·067342
140	15·100	0·066221
150	15·352	0·065140
160	15·603	0·064088
170	15·854	0·063072
180	16·106	0·062090
190	16·357	0·061134
200	16·606	0·060210
210	16·860	0·059313
212	16·910	0·059135
220	17·111	0·058442
230	17·362	0·057596
240	17·612	0·056774
250	17·865	0·055975
260	18·116	0·055200
370	18·367	0·054444
280	18·621	0·053710
290	18·870	0·052994
300	19·121	0·052297
320	19·624	0·050959
340	20·126	0·049686
360	20·630	0·048476
380	21·131	0·047323
400	21·634	0·046223
425	22·262	0·044920
450	22·890	0·043686
475	23·518	0·042520
500	24·146	0·041414
525	24·775	0·040364
550	25·403	0·039365
575	26·031	0·038415
600	26·659	0·037510
650	27·913	0·035822
700	29·172	0·034280
750	30·428	0·032865

and volume of air at different temperatures. If the air entering the boiler furnace is very moist, containing, say, 10 per cent. of watery vapour, and it is at a temperature of, say, 100° F., the weight of oxygen delivered to the furnace per cubic foot of air passing in, is only 0.0134 lb. instead of 0.01604 with dry air at 60°. The quantity of the vapour of water present in the air varies with the climate and with the seasons. In this country the largest proportion of the possible quantity of vapour is present in the air during the winter months, the proportion being, according to Box, 66.1 per cent. of the possible quantity in August, 68.5 in July, 71.0 in June, 81.0 in February, 85.8 in January, 85.6 in November, and 86.8 in December. On the other hand, the quantity of moisture the air can carry is highest during the hot summer months of July and August, and is lowest in the winter months. The quantity of moisture that the air can carry, as already explained, depends upon the temperature, in accordance with the law mentioned on p. 25, and it depends upon the elastic force of the vapour of water at that temperature. At 212° F. the elastic force of the vapour is 29.962, this being the point at which vapour comes away freely, as already explained, in the process of boiling, this figure and the following ones being for the standard atmospheric pressure. At 102° F. the elastic force of the vapour, or the vapour pressure, as it is often expressed, is = 2.036 inches of mercury, or 0.968 lb. per sq. in. At 92° F. it is = 1.501, or 0.736 lb. per sq. in.; at 82° it is 1.092, or 0.54 lb. per sq. in.; at 72° it is 0.785, or 0.39 lb. per sq. in.; at 62° it is 0.556, or 0.276 lb. per sq. in.; at 52° it is 0.388, or 0.194 lb. per sq. in.; at 42° it is 0.267, or 0.133 lb. per sq. in.; and at 32° it is 0.181, or 0.09 lb. per sq. in. It will be seen from the above figures, that though the percentage of the possible moisture that can be carried by the air is greatest in winter, the actual quantity may be smaller at the low temperatures prevalent. Thus, taking a temperature of 42° when the vapour pressure is 0.267, and taking a percentage of saturation 80 per cent., or the possible quantity of vapour that may be carried, the actual quantity present will represent a vapour pressure of 0.227 inch of mercury; while at 92°, with a percentage of 66, the actual quantity present will represent a vapour pressure of 0.99, or roughly  $4\frac{1}{2}$  times that present with the lower winter temperatures. In the experiments made by Mr. Gayley at Pittsburgh, when he was working out the arrangement for drying the air for the blast furnaces that he has since established, he found different quantities of vapour present in the air at different times, the variation following the rules given above very largely, but there being large variations from day to day, and from hour to hour.

It will be understood, from what has gone before, that the pressure of the air, as distinguished from the pressure of the combined mass of air and water in the atmosphere, will be the average

pressure at the height where the boiler and engine is fixed, less the pressure of the water vapour, and that the weight of air passing into a furnace, and therefore the weight of oxygen, will follow this law.

## Measuring the Percentage of Vapour in Air

The percentage of vapour present in air is measured by taking the difference in the readings between two thermometers, one of which is exposed to the ordinary temperature of the air, the other being exposed to the cooling effect of the evaporation of water. The usual method is—two thermometers are fixed side by side, one being exposed to the ordinary temperature of the air, and the other having some textile porous fabric, such as a piece of waste, or tow wrapped round its bulb, the waste dipping into a vessel containing water. The evaporation of the water contained in the waste extracts heat from the bulb of the thermometer, and lowers the reading shown by it, the evaporation being directly in proportion to the difference between the percentage of saturation of the air, and full saturation. From the difference between these two readings, the percentage of saturation may be obtained by a table that was worked out by Mr. Glaisher at Greenwich some years ago, and is given below.

TABLE X.

Temperature of the air.	Degrees of cold in the wet-bulb thermometer.																						
	1	2	3	4	5	6	7	8	9	10	11	12	13	14	15	16	17	18	19	20	21	22	23
	Degrees of humidity, saturation being 100.																						
32°	87	75	—	—	—	—	—	—	—	—	—	—	—	—	—	—	—	—	—	—	—	—	—
42°	92	85	78	72	66	60	54	49	44	40	36	33	30	27	—	—	—	—	—	—	—	—	—
52°	93	86	80	74	69	64	59	54	50	46	42	39	36	33	30	27	25	—	—	—	—	—	—
62°	94	88	82	77	72	67	62	58	54	50	47	44	41	38	35	32	30	28	26	—	—	—	—
72°	94	89	84	79	74	69	65	61	57	54	51	48	45	42	39	36	34	32	30	28	26	24	23
82°	95	90	85	80	76	72	68	64	60	57	54	51	48	45	42	40	38	35	33	31	29	27	26

The above method is known as that of the wet and dry bulb, but when carried out as described, it is open to grave objections, which affect its accuracy. When the two thermometers merely stand side by side, with the air not in motion about them, the full effect of the unsatisfied saturation of the air is not obtained, the effect of the air upon the wet bulb being masked to a large extent by the layer of still air immediately in contact with it. It will be understood, from

what has been explained about the saturation of air, that if the air immediately surrounding the bulb, becomes itself saturated, and is not moved away, evaporation from the fabric surrounding the bulb will then cease, and an apparent measurement will be taken, showing the hygrometric state of the atmosphere at a higher point of saturation than it really is. To meet this difficulty, two methods have been adopted. The air in the neighbourhood of the two thermometers may be simply agitated with a fan, so that the masking layer of still air is disturbed, and something like a convection current set up. A more satisfactory method, however, which the author believes comes to us from America, consists in mounting the two thermometers together on a handle arranged for whirling round the heat on the lines of some children's toys. One of the thermometers has its bulb surrounded by a moistened pad, as before, and the two are whirled rapidly round the head, in the body of the air whose hygrometric state is to be measured, for several seconds, and the readings then taken, and these are stated to be as correct as can be obtained.

## Volume and Pressure

The volume of air varies inversely with the pressure, in accordance with the following formula:  $pv = \text{a constant}$ . That is to say, the product of the two factors,  $p$  and  $v$ , representing respectively pressure and volume, is constant. If the pressure increases, the volume decreases in the same proportion. Thus, compressing air to double its previous pressure, reduces its volume to half, and *vice versa*.

This, again, is of importance when air is delivered to a furnace under pressure, as any pressure to which it is subject will reduce its volume. When air is compressed, heat is liberated in the air, the heat representing the energy expended upon the air in the act of compression, and the heat delivered to the air expands it in the proportion given above, so that any force which tends to compress the air, such as the apparatus employed in forced draught, or the increase of barometric pressure, tends at the same time to diminish the volume of the air by the increased pressure, and by liberating heat in the air, to increase the volume of the compressed air, and so to resist the act of compression.

## The Specific Heat of Air

The specific heat of air is usually given in two forms, under constant pressure, and under constant volume. The specific heat of air at constant pressure is usually taken as 0.238, and at constant volume, 0.169, water being taken as unity. It should be mentioned, however,



that the specific heat of air is often taken as unity for comparison with that of gases. When air and other gases are heated in closed vessels, so that expansion cannot take place, and the pressure is necessarily increased, a smaller quantity of heat will raise the temperature of the air by 1° F. than when the air is allowed to expand so as to maintain its volume constant. This is the explanation of the two figures given. In practice, air is never heated under constant pressure, and never so that it can maintain its volume constant, the conditions usually being that both pressure and volume are increasing, so that the actual specific heat of the air is somewhere between the two figures, and it will not be far wrong to take it as about 0.2. The following table gives the specific heat of the other gases that are met with in boiler work—

TABLE XI.

	Specific heat at constant pressure.	Specific heat at constant volume.
Oxygen gas . . . . .	0.2182	0.1542
Hydrogen gas . . . . .	3.4046	2.4200
Nitrogen gas . . . . .	0.244	0.1717
Carbonic acid . . . . .	0.2164	0.1617
„ oxide . . . . .	0.2479	0.1737
Vapour of water . . . . .	0.475	0.3624

The very high specific heat of hydrogen gas will be noted, and its great importance, if free hydrogen is present, in any process of combustion.

The specific heat of air varies also with the pressure, both with constant pressure and constant volume. The variations are given in the following table—

TABLE XII.

Pressure in inches of mercury.	Specific heat with pressure constant and volume variable.	Specific heat with volume constant and pressure variable.
1	1.303	0.9170
5	0.5827	0.4101
10	0.4121	0.2900
20	0.2914	0.2050
29.92	0.238	0.169
40	0.2061	0.145
60	0.168	0.1184
80	0.1457	0.1025
100	0.1306	0.0919
180	0.0971	0.0684
300	0.0752	0.0529

The importance of this table comes in with high pressures in the boiler, and with low pressures in the condenser. With high pressures, the air with which the gases formed by combustion are diluted, absorb a smaller quantity of heat to raise them to the furnace temperature, and in the condenser the air present will absorb a larger quantity of heat than at ordinary atmospheric pressures.

## Water

Water is a chemical compound of hydrogen and oxygen gases, the formula being  $H_2O$ , two molecules of hydrogen combining with one molecule of oxygen to form one molecule of water. By weight, 16 parts of oxygen combine with 2 parts of hydrogen. As already explained, water exists in all three states, in the solid state as ice and as snow; in the liquid state as water; in the gaseous state as steam, and in a not quite understood state as vapour. Water has the important property of dissolving almost every known substance, solid, liquid, and gaseous. Water comes to us originally from the clouds. As explained, evaporation is constantly taking place from the oceans, rivers, and the surface of the earth, the evaporation depending, at any instant, upon the temperature of the atmosphere, and upon the quantity of the vapour of water already present. Put in another way, the vapour which is issuing from the water on the earth's crust has a certain tension of its own, and the vapour which is present in the atmosphere has also a certain tension. When these two are equal no evaporation can take place; while when the tension of the vapour issuing from the water is greater than that of the vapour present in the air, evaporation goes on more or less freely, approximately in proportion to the difference between the two vapour tensions. When the tension of the vapour in the air is greater than that of the vapour issuing from the water, evaporation ceases, and some of the moisture present in the atmosphere is deposited upon the ground or upon the water.

As explained on p. 27, the tension of the vapour issuing from the water depends upon the temperature of the water, while the tension of the vapour already present in the atmosphere depends upon the temperature of the atmosphere, and the percentage of possible vapour, of possible saturation by vapour, that is present. If the water and the air are at the same temperature, and the air is saturated, neither evaporation nor deposit can take place. And the same conditions may rule if the temperature of the water is comparatively low, while the temperature of the air is comparatively high, and the percentage of saturation is large. The formation of dew at night is caused by the ground in any particular position

cooling by radiation after it has ceased to receive the sun's rays, the vapour issuing from it becoming considerably lowered in tension, while the vapour of the air above it may have a considerable tension, due to its higher temperature and to its state of saturation, and deposit then takes place.

The water evaporated from the earth forms into clouds, and afterwards descends as rain, falling first upon the high lands, the clouds also being driven before the winds that blow from time to time. The water that descends from the clouds, if in the form of rain, runs down the surface of the ground, forming rivulets, which deliver their water to streams, these again delivering their water to rivers, which deliver to larger rivers, and so on, the large rivers delivering to the oceans. But a considerable portion of the water which falls upon the surface of the ground sinks into it, some of it going to nourish the plants, etc., that are growing, and some falling upon what are called the water-bearing strata, which outcrop at the surface of the ground in various positions, and usually descend into the ground at an angle with the vertical. The water that is obtained by sinking wells, is that which has fallen upon the outcrop of the water-bearing strata, and has descended through it to different depths. Water-bearing strata are the porous rocks, such as sandstone, and the loose earths, such as gravels, and some kinds of sand.

The reservoirs that are made for the supply of water to towns, are formed by collecting all the streamlets running down the sides of the hills in the high lands above the towns over a considerable area, and preventing their running away in the streams, etc., as mentioned above, by fixing dams across convenient spots, such as the junctions of two or more valleys, where a considerable depth of water can be impounded, the water being carried from there by pipes into the town.

The water which runs down the sides of hills and mountains, and at the bottoms of valleys in streams and rivers, dissolves a certain portion of the substance of the rocks, etc., over which it runs, and also carries off a certain quantity, in a finely divided state, the friction of the running water loosening some of the particles of the rock or earth over which it is running, and the running stream carrying the particles along with it. The ability of water to dissolve portions of the rocks, etc., over which it runs, leads to the formation of the natural mineral springs that are found all over the world, having certain medicinal properties, and it also leads to the waters employed for boiler purposes containing the salts, mainly of lime, magnesium, and sodium, which confer on the water the property known as hardness.

Water has also the property of dissolving pretty well all gases and liquids, and there is a peculiar feature in connection with the



solution of gases in water. Gases, it will be remembered, exist in the gaseous state, because they are possessed of a certain quantity of latent heat. When a gas is dissolved in water, it delivers its latent heat to the water, in the process of solution, the water being heated by the liberated latent heat.

## Impurities in Water

As will be seen when dealing with boilers, the impurities which the water collects in its passage over rocks, etc., have a very serious effect upon the heating power of boilers, inasmuch as the substances carried by the water, whether in solution or mechanically, are deposited upon the water side of the heating surfaces, and gradually build up a scale that offers considerable resistance to the passage of the heat through the metal separating the water and the hot gases. The principal substances found in water are the carbonates and sulphates of calcium and magnesium,  $\text{CaCO}_3$  and  $\text{MgCO}_3$ ,  $\text{CaSO}_4$  and  $\text{MgSO}_4$ . Other substances that are found frequently are the carbonates of iron,  $\text{Fe}_2\text{CO}_3$ , and the chlorides of calcium, magnesium, potassium, and sodium,  $\text{CaCl}_2$ ,  $\text{MgCl}_2$ ,  $\text{KCl}$ ,  $\text{NaCl}$ . Sodium chloride is the principal foreign component of sea water.

The apparatus for dealing with impurities in the water with which boilers are to be fed, are dealt with in their section, on p. 182. They operate principally by the application of heat, and the addition of certain substances which render the dissolved salts in the water insoluble, and precipitate them before the water is allowed to enter the boiler. The carbonates are not soluble in water, but the bi-carbonates are. The carbonates are the salts given above, in which only one molecule of carbonic acid is present in combination, but the bi-carbonates have two molecules of carbonic acid, the addition of the second molecule rendering them soluble in water. The application of heat to the water drives off the additional molecule of carbonic acid, and the carbonate is then deposited. If the carbonic acid is removed from the water before it enters the boiler, and the carbonates are allowed to deposit in some vessel outside of the boiler, the water is rendered harmless so far as those salts are concerned; but if the water is allowed to enter the boiler with the bi-carbonates in solution, as the second molecule is driven off at a maximum temperature of  $290^\circ \text{F}$ ., or when the steam is at a pressure of 58 lbs. absolute, or 43 lbs. gauge, the carbonates remaining are deposited on the metal in the water space itself. The sulphates and chlorides are got rid of by the addition of carbonate of soda,  $\text{NaCO}_3$ , and caustic lime,  $\text{CaH}_2\text{O}$ , in proportions depending upon the quantity of the salts present.

The presence of the impurities in the water lead to other troubles, such as priming, etc., that will be dealt with when describing boilers and their working.

## Steam

As already explained, steam is water in the gaseous state, and is produced from water by the application of heat, different quantities of heat being required to evaporate a given quantity of water, according to the pressure to which the surface of the water is exposed, and according to the percentage of salts held in solution in the water.

Steam as it comes away from the surface of water in the boiler, is known as saturated steam. The term "saturated" means here, that the steam is of the maximum density at the particular temperature. In the table of the properties of saturated steam given on p. 124, it will be noted that the temperature, the latent heat, the total heat, the volume per cubic foot, the weight per cubic foot, and the quantity of steam produced from one cubic foot of water are given in the successive columns. The volume per cubic foot is, of course, only another name for its density, and it will be noticed that the volume steadily decreases, the density increasing in the same proportion as the pressure increases. Thus at 1 lb. per square inch absolute pressure, the volume is 330·4 cubic feet per pound, at 2 lbs. pressure it is only 172 cubic feet; at 10 lbs. it is 37·8 cubic feet; at 14·7 lbs., or atmospheric pressure, it is 26·37 cubic feet; at 50 lbs. it is 8·34 cubic feet; at 100 lbs. it is 4·34, and at 200 lbs. it is 2·26, and so on. Saturated steam has certain properties of its own, in particular, with reference to the transmission of heat through iron pipes. According to Professor Siebel, the authority on refrigeration, the rate of transmission of heat from saturated steam through an iron pipe to water on the other side of the pipe, is only one quarter that at which heat is transmitted from hot water in an iron pipe, to water on the other side of the pipe. Saturated steam, however, is very rarely pure steam. That is to say, taking steam to be a gas, and to have all the properties pertaining to gases, the steam from steam boilers carries in it the vapour of water, or finely divided globules of water, very much in the same way as air carries the vapour of water, as already explained. The vapour of water, or the globules of water held in suspension, introduce a source of loss in steam engines, owing to the facility with which on the steam meeting surfaces of slightly lower temperature than itself, the water carried in suspension condenses on those surfaces, being afterwards formed into steam at the expense of heat taken from the metal surfaces upon which they were condensed.

## Superheated Steam

To meet the above difficulty of the condensation of the water carried over from the boiler, it is now common to subject steam on its way to the engine, or turbine that is to use it, to a process known as superheating. Various forms of superheaters are described later in the book, but the object of all is, the heating of the steam, out of contact with the water from which it was formed, and the formation of all the watery globules, or watery vapour that is carried in suspension, into proper steam at the pressure and temperature of the steam which carries it. The process of superheating confers certain valuable properties upon the steam, that it does not possess in the saturated form. Superheated steam, according to Professor Siebel, transmits heat through an iron pipe, to water on the other side of the pipe, at only  $\frac{1}{40}$ th the rate that saturated steam does. It need hardly be pointed out what a very valuable property this is, in all apparatus where work is to be obtained from steam by its expansion, and by mechanical work obtained in the process of expansion. Any heat the steam loses by conduction to the cylinder or pipes through which it passes, robs it of a portion of the energy it would expend in driving the piston, or in turning the blade of a turbine wheel. In addition to the above, the specific heat of steam being only about 0.5, the steam produced from a pound of water will have its temperature raised in the proportion of 2 to 1, about, by the application to it of any definite quantity of heat. If the steam to be superheated is in a closed vessel, unable to escape, as when the engines are not taking steam, the application of heat in the process of superheating will raise the pressure of the steam, with the temperature, the pressure and temperature of steam going together in accordance with the figures given in Table 8. Where, as will more usually be the case, the steam is superheated on its way from the boiler to the engines, and is therefore free to expand, its volume will increase with the application of heat, in the same proportion as its pressure would if confined. In considering the question of superheating, it is important to know the quantity of vapour or watery globules present in the steam, and the superheating apparatus, whatever it may be, must provide sufficient heat during the passage of the steam through it, to raise the whole of the water present to the condition of proper steam, at the temperature to which the steam itself is raised. In practice, the maximum quantity of vapour that can be carried over by the steam, under ordinary working conditions, is found by test, and the superheating apparatus is arranged to furnish the necessary heat required for converting this maximum quantity of water into steam during the passage of the steam through the superheater.

## Specific Heat of Superheated Steam

The specific heat of superheated steam at atmospheric pressure is taken at 0.48, but according to recent measurements, the specific heat of steam, superheated to 100° F. above the saturated state, is 0.65, and with 200°, 0.75. It is frequently taken as 0.5 for calculations.

It should be noted that the remarks made above, with reference to the additional work to be got out of superheated steam, owing to the lower specific heat, applies to a large extent to steam generated in the boiler, at higher than ordinary atmospheric pressure. Modern practice has tended to gradually increasing steam pressures. In the early days of steam, the old Cornish pumping-engine worked at only a few pounds above atmospheric pressure, the vacuum produced by condensing under the piston being relied on very largely for the work done by the engine. Even as late as thirty years ago, steam pressures of 30 lbs. or thereabouts, were very common all over the United Kingdom. Gradually, however, the pressures used have increased, first to 50 lbs., then to 80 lbs., and now pressures of 250 lbs. per square inch are not uncommon, and the increased pressures all tend to economy in coal, partly for the reason given in connection with the superheating of steam, because the specific heat of steam is so much lower than that of water, and partly because, as mentioned in a previous paragraph, the latent heat of steam steadily decreases, as the pressure increases. And it is the latent heat which forms practically the great source of waste with steam. The more the latent heat can be reduced, the more economical is the use of steam, providing that the energy delivered to the steam is economically applied.

## Carnot's Law of the Efficiency of Heat Engines

The law of the efficiency of all heat engines, steam, gas, etc., which was enunciated by the French savant Carnot some eighty years ago, still rules in the heat-engine world. It is as follows:—

$$\text{The efficiency} = \frac{T_1 - T_2}{T_1}. \quad \text{The formula is sometimes written}$$

$$\frac{T - T_1}{T}.$$

Where  $T_1$  is the *absolute* temperature at which the heat is received by the engine, and  $T_2$  is the *absolute* temperature at which it is rejected.

In using this formula, another law of heat operation rules, viz. that the final result of successive changes of heat is irrespective of the method of the changes and the steps. In the case of steam, the

law may be applied separately to the boiler, to the engine, and to the condenser, or, as is more usual, it may be applied to the combination as a whole. It means that the greater the difference of temperature between the steam generated by the boiler, and that finally ejected from the exhaust of the engine, the higher is the efficiency of the plant as a whole, the greater the proportion of the heat delivered to the water that is recovered from the crank-shaft of the engine, or the shaft of the turbine. The law may be carried further back to the temperature of the furnace, and will be equally applicable, the higher the temperature of the furnace and the lower the temperature of the steam, finally ejected from the exhaust, the higher is the efficiency of the plant, and the lower the consumption of coal in the boiler furnace per B.H.P. at the steam motor-shaft should be.

It will be seen that this law explains a good many things that are at first somewhat puzzling, such as the very large increase of efficiency obtained from the steam turbine by increased vacuum, and the increased efficiency of any steam plant, with higher steam pressures. The above is subject to the steam and the heat being usefully applied. Any leakage of heat, such as radiation from the boiler surface, from the steam-pipes, and from the surface of the engine cylinders, which all go to increase the range of temperature, decrease the efficiency of the heat combination.

## Fuel and Combustion

In all boiler plant heat is obtained by the combustion of fuel in a furnace, either forming part of or attached to the boiler. By combustion is meant the chemical combination of certain components of coal, wood, oil, and other substances with oxygen. As the author understands the matter, gases exist in the gaseous state by virtue of the fact that they are possessed of a certain quantity of energy, enabling them to exist as gases; and in addition to this, every gas exists as that gas by reason of the possession of a certain quantity of energy peculiar to itself, as distinguished from its own latent heat. Put in another way, the energy possessed by gases of different forms varies very considerably. The energy possessed by hydrogen gas is apparently very much larger than that of any other gas. Oxygen possesses a large store of energy, while carbonic acid and carbonic oxide exist with a very much smaller quantity. Hence, when any substance, such as carbon, combines with oxygen, though a certain quantity of energy is demanded to convert the carbon to the gaseous state, the energy required to enable carbonic acid to exist as a gas, is so much less than that required for the existence of oxygen as a gas, that a certain quantity of energy is liberated in the

form of heat. The quantity of energy liberated by the combination of certain substances has been measured by different experimenters, as given below.

(1) Carbon oxidizing to carbonic oxide, 4500 B. Th. units, or 2416 calories.

(2) Carbon oxidizing to carbonic acid, 14,500 B. Th. units, or 8080 calories.

(3) Hydrogen combining with oxygen to form water, 62,000 B. Th. units, or 34,180 calories.

(4) Sulphur oxidizing to  $\text{SO}_2$ , 4000 B. Th. units.

The above figures for the calorific values are to be taken as approximate. They are near enough for all practical purposes, and the qualification just named is given because different experimenters appear to have obtained different results. All the results are in the close neighbourhood of the figures given.

The heat liberated by the combination of other elements with oxygen has also been measured, but carbon and hydrogen and sulphur are the only elements that concern us. All known fuels owe their useful calorific value to the presence of these elements. Sulphur occurs to a small extent in coal, but its combining value is not of great importance. It is always eliminated where possible.

## Calorific Power

By calorific power is meant the heat which is liberated by the combination of 1 lb. of the substance with oxygen. It is also frequently written as "calorific value." The meaning of either expression is, the comparative ability of the different substances to liberate heat, when a definite quantity of the substance combines with oxygen.

The calorific powers of the principal fuels have been determined by careful experiment. They all depend upon the quantity of carbon and hydrogen that are present in them, modified by the quantity of oxygen that is also present in nearly all of them. Hydrogen and oxygen have a strong affinity for each other, and will combine to form water whenever the opportunity occurs. In the great majority of fuels, while a certain quantity of hydrogen is present, a certain quantity of oxygen is also present, and before the calorific value of a fuel is determined theoretically, the quantity of hydrogen required to satisfy the quantity of oxygen present is deducted from the total quantity of hydrogen, the remainder being taken with the carbon. Thus, as hydrogen combines with eight times its own weight of oxygen,  $\frac{1}{8}$  of the weight of oxygen present may be deducted from the weight of hydrogen. Dulong's formula for calculating the calorific value of any fuel is as follows:—

$$\left. \begin{array}{l} \text{Calorific value per} \\ \text{pound of the fuel} \end{array} \right\} = 14,554 C + 61,524 \left( H - \frac{O}{8} \right) + 4000 S$$

where C, H, O, and S represent the proportionate parts of carbon, hydrogen, oxygen, and sulphur respectively.

## Forms of Fuel

The available fuels are: the different forms of coal, wood, the refuse from sugar-canes, cotton trees and similar things, peat, petroleum in its various forms, oils of various kinds other than petroleum, natural gas, blast furnace gas and producer gas, corn, maize, oak bark, sugar. Some forms of dried manure and other substances have all been used. Any substance, in fact, containing carbon, or carbon and hydrogen, may be employed as a fuel, providing that its temperature can be raised to ignition point, and that it can be supplied with oxygen.

## Coal

Coal is found at various depths in the earth's crust, ranging from 0, or the outcrop, as it is termed, down to depths of 1000 yards at present being worked, while deposits are also believed to exist at still greater depths. The coal has all been formed in the same manner, so far as is known at present. In the places where coal beds now exist, plants of a certain character grew in ages long gone by, probably millions of years ago. The plants apparently grew principally in clay soils, as most of the coals are underlaid by clay of various forms. The plants died, and by the succeeding operations to which the earth's crust was subject, they were buried by overlying strata, the sites where they had grown usually being submerged after the plants had died, and there has been a gradual accretion of overlying strata gradually pushing the coal seams lower and lower down beneath the surface. The coal seams occur in nearly every part of the world, and they vary in thickness from a very few inches up to as much as ten yards. In this country they lie in basins, spread out so that the edges of the seams come out to the surface on each side of the basin, and the seam itself is inclined to the vertical, and is found at lower and lower depths as it recedes from the outcrop. In other parts of the world—in China, for instance—the coal seams are stated to lie in large basins, almost horizontal. Volcanic action has been very busy wherever the coal seams have been formed, has disturbed the lay of the strata, and in addition has created a considerable amount of uncertainty as to what condition the coal

will be found in when it is reached, in different parts of each coal basin.

## Forms of Coal

Coal exists in very variable forms—brown coal or lignite, which is found in very large quantities in Bohemia, Italy, and other parts of the world, and in small quantity in Devonshire; bituminous or true coals, as they are sometimes called, semi-bituminous, or semi-anthracites, anthracite, and cannel.

Peat, though it is taken to be a distinct substance, is apparently the early form of coal. It is formed on the surface in marshy districts, very large quantities being found in Ireland, in the well-known peat bogs, and a considerable quantity in the low-lying parts of Somersetshire and elsewhere. Peat is formed from certain plants which die down, but which do not cease to grow after they have ceased to furnish vegetation upon the surface. At the same time, fresh plants are produced at the surface in each season, which in their turn die, and go to add to the mass of peat lying below them, with the result that the lower layers are subject to a certain amount of pressure, similar to, but very much smaller than the pressure to which the coal seams have been subject, and the nature of the lower layers is gradually altered, the colour of the top layers being light brown, while that of the lowest layers will be nearly black. And while the top layers consist of the tangled roots and stems of the plants, clearly distinguished, the lower layers have been pressed into a more or less compact mass, in which the stems and roots of the plants are not easily distinguishable. Peat contains a very large quantity of moisture, and the process of getting it consists in cutting the layers into square portions, and stacking them up something after the manner of haystacks, but with air spaces between the different layers, so that the air can penetrate and carry off the moisture in the same manner as in the water-cooling towers that will be described later on. Even when thoroughly dried, so far as it can be in this manner, peat still contains a large percentage of water held in suspension in its pores, and hence its value as a fuel is considerably reduced, since, as will be explained, the water which is present in the pores of a fuel, takes heat from that liberated by the combustion of the fuel, to convert itself into steam, and as all water takes in the neighbourhood of 1200 heat units per lb. to raise its temperature to boiling-point and convert it into steam, the loss may be a very serious one.

The composition of peat, leaving out water, which may be as much as 20 per cent after air-drying, ranges from 54 to 61 per cent. of carbon, 5 to 7 per cent. of hydrogen, from 28 to 32 per cent. of



oxygen, and from  $1\frac{1}{2}$  to  $2\frac{1}{2}$  per cent. of nitrogen, and from 2 to 10 per cent. of ash. Ash is the residue of incombustible matter that remains after the fuel is burned. It consists of the following substances: silica in the proportion of from 29 to 53 per cent. of the total amount of ash present, alumina and oxide of iron in the proportion of 35 to 87 per cent., and lime from 4 to 12 per cent., with small quantities of magnesia, anhydrous sulphuric acid, and phosphoric acid. The quantity of ash in different coal varies from 3 up to 15 per cent.

Both nitrogen and the incombustible ash lower the calorific value of the fuel, because neither of them bring any additional heat to the common stock, and both of them absorb heat while the process of combustion is going on, to raise themselves to the temperature of the remainder of the burning mass. It will be understood that in a furnace, or wherever fuel is in process of combustion, any substance that is present will assume the temperature of the remainder of the burning mass, if and as far as it is able to do so.

The coals, commencing with peat, appear to follow a regular gradation, approximately according to their age, and the pressure to which they have been subjected by the overlying strata. After peat come the brown coals or lignites, in which the carbon ranges from 46 up to 60 per cent., the volatile matter from 40 to  $54\frac{1}{2}$  per cent., the sulphur from 0 to 3 per cent., the ash from 1 to  $12\frac{1}{2}$  per cent., and the moisture from 1 to 25 per cent. Next come the bituminous coals, in which the carbon ranges from 50 to 75 per cent., the hydrogen from 4 to  $5\frac{1}{2}$  per cent., the oxygen from 3 to 20 per cent.

Next come the semi-bituminous, or as they are sometimes called, the semi-anthracite coals, which stand between the bituminous and the pure anthracites. Striking examples of these coals are the well-known smokeless steam coals of South Wales, and the Pochahontas coals of Western Virginia, U.S.A. In these coals the carbon ranges from 75 to 90 per cent., the hydrogen is in the neighbourhood of 5 per cent., and the oxygen from 5 to 7 per cent.

In the pure anthracite coals, the carbon ranges from 90 to 98 per cent., hydrogen and oxygen making up the remainder.

## Cannel Coal

Cannel coal is a distinct variety, which is of great value for making gas, as it contains such a large quantity of gaseous, or volatile matter. It is of great value commercially for gas making, but is not much employed for steam raising. The cannel coals contain from 26 to 55 per cent. of carbon, and from 42 to 64 per cent. of volatile matter, and from 2 to 14 per cent. of ash.

## The Differences between the Coals

As already explained, the principal difference between the coals, so far as steam raising is concerned, is the quantity of carbon and hydrogen, ash and moisture they contain respectively. But there are other distinguishing features. Thus bituminous coals are so called because on heating, in a closed vessel, liquid bituminous substances are given off. The bituminous coals are very largely used for raising steam, but they have not such a high value as the semi-bituminous and anthracite coals. The bituminous coals also contain considerable quantities of volatile matter in the form of hydrocarbons, and it is the hydrocarbons which largely go to make smoke, and which are therefore wasted when they appear as smoke. As will be explained later, one of the difficulties of the boiler maker and the boiler attendant, is the complete combustion of the volatile matter in some of the coals, notably the bituminous variety. Unless the whole of the volatile matter is completely burned, completely oxidized, it passes through the furnace and the boiler flues, doing very little good in the way of heating the water and the steam, and then passes out into the atmosphere, and gives rise to the smoke we are familiar with.

In the semi-bituminous coals the hydrocarbons, so largely present in the bituminous coals, are almost absent, and hence the claim for smokelessness raised by South Wales coal-owners. In Nature's laboratory, many hundred yards below the surface of the ground, the vegetable matter of the plants from which the coal is formed is gradually changed, the hydrocarbons being apparently first separated from the carbon, but held in the coal, ready to give way with a slight application of heat, and at a further stage the hydrocarbons are decomposed, the percentage of carbon being increased, and the gases which are found in such large quantities in semi-bituminous and anthracite coal seams are formed, and are held under very considerable pressure, within the pores of the coal, ready to give out immediately the pressure is lowered.

In the anthracite variety the process is complete, as far as Nature is able to carry it, and the coal consists almost entirely of carbon, with the gases mentioned held in its pores.

## Carbon and Volatile Matter in Coals

In referring to the different qualities of coal above, the term "volatile matter" was used, and it will be found in every description of coals that is met with. The meaning is as follows. There are

three methods of testing the calorific value of any fuel, known respectively as proximate analysis, ultimate analysis, and calorimetry. In the proximate analysis a small quantity of the fuel is subjected to a temperature of from 250° to 300° F. to expel any moisture that may be present, and it is then heated to redness, the volatile matter being driven off at this temperature. After the volatile matter has been expelled, the residue is further heated to a white heat, at which temperature the carbon present combines with oxygen, and passes off as carbonic acid. The residue is weighed after each operation. The percentage of the original sample remaining after heating to redness is given as a percentage of carbon. The difference between the weight of the sample before heating, and its weight after the moisture has been driven off, is evidently the weight of moisture present. The difference between this weight and that after heating to redness is the quantity of volatile matter. The difference between the weight remaining after heating to redness, and that after the carbon has all been oxidized, is the weight of carbon, and the remainder is the weight of ash. It is usual to express the quantities as percentages. The volatile matters are the hydrocarbons mentioned above.

In ultimate analysis the actual percentages of carbon, hydrogen, oxygen, nitrogen, sulphur of ash are accurately determined, and in estimating the heating value of a given fuel, it is these quantities that are employed, Dulong's formula, given above, being employed.

## Calorimetry

It will be evident, however, that neither the proximate analysis nor the ultimate analysis can give an accurate estimate of the heating value of a fuel, because neither of them show how the different elements are combined in the fuel, and their combination has a most important bearing upon their heating value. Combustion, as explained, is a chemical operation, and nearly all chemical operations in which heat is either liberated or absorbed, are made up of several subsidiary operations, some of which liberate heat, and some of which absorb heat, the final result being the algebraical sum of the whole of the operations. In the great majority of cases, when two substances combine, particularly when a solid combines with a gas, heat is liberated; and, on the other hand, when a compound is split up into its components, heat is absorbed. As the different elements contained in coal may be present, partly in combination with each other, partly in the free state, both the ultimate and proximate analyses can only give an approximate measurement of the calorific value of the fuel. A nearer estimate is obtained by the use of the

calorimeter, of which there are several forms. The principle of the calorimeter is the heating of a definite quantity of water by the combustion of a definite quantity of the fuel to be tested. The calorimeter consists of a vessel containing a definite quantity of water. In one form the quantity of water is 2 litres, equal to 3.52 pints. The vessel containing the water is carefully insulated thermally, from the ingress or egress of heat, and a smaller vessel, sometimes called a cartridge, in which the fuel is to be placed, is inserted in the vessel containing the water. The fuel is ground to a powder, sufficiently small to pass through a sieve of 100 meshes to the inch, and is dried before being placed in the cartridge. A thermometer is fixed in the vessel containing the water, its stem projecting above, so that its indications can be read, and the vessel containing the fuel is also arranged on pivots, so that it can be rapidly revolved. Different arrangements are made for igniting the fuel after everything is ready. The fuel is burned under the conditions named above, and the rise of temperature of the water is taken, this furnishing a definite measurement of the heating value of that particular fuel. The measured results by calorimeter, and the calculated results from Dulong's formula, do not vary to any great extent, if care is taken in the experiment. From a list of measurements taken with W. Thomson's calorimeter, as compared with the calculated values from the ultimate analysis of different English, Welsh, and Scotch coals, the differences range from 0.3 per cent. up to 10 per cent., the average of the cases taken being a difference of only 1 per cent.

## Wood

In certain parts of the world, notably California, large portions of Asia, Africa, and South America, there is no coal available, the cost of freight from the nearest coal field is very high, and consequently in those districts where wood is plentiful, it has been largely used as a fuel for raising steam. As will be seen when dealing with boilers, special arrangements are necessary for burning wood, and the wood itself has not the same calorific value as any of the forms of coal that have been mentioned, or peat. The composition of wood ranges from 48 to 50 per cent. of carbon, about 6 per cent. of hydrogen, from 39 to 44 per cent. of oxygen, a small quantity of nitrogen, and from 2 to 4 per cent. of ash, the calorific value ranging from 7800 B. Th. units, up to 9000. It will be noticed that the proportion of oxygen is very large, so that the hydrogen present is practically neutralized. Wood contains from 20 to 25 per cent. of moisture, even when it is what is known as air dried. In its natural condition when felled, the moisture present ranges from 30 to 50 per cent. by weight, this

amount being reduced to from 20 to 25 per cent. if the wood is exposed to an air current for a considerable time. The large percentage of moisture present seriously reduces the practical heating value of wood as a fuel, since the moisture has to be raised to the temperature at which steam is formed, and has also to be converted into steam at the expense of the heat liberated by the combustion of the remainder of the components. The net calorific value, therefore, of air-dried wood will not exceed 6500 B. Th. units per pound, and that of wood when first felled will be in the neighbourhood only of 4000 B. Th. units. The calorific values of the different woods vary very little among themselves, though the specific gravity varies very considerably, from 0.4 up to 1.0. Wood is sold by the cord in America, and by what is known as string measure in this country, and the comparative values of a certain quantity of wood will vary with its specific gravity. Thus any given quantity by measure of the lighter woods, such as pine, poplar, chestnut, sycamore, cedar, etc., will have only approximately half the calorific value of a similar quantity by measure of the heavier woods such as oak and hickory, while beech and ash will have about three parts the calorific value for the same quantity by measure.

### **Spent Tan, Straw, Bagasse, Corn Stalks, and other Organic Refuse**

There are several forms of fuel that are employed for steam raising that are the refuse from different industries, such as tanning, wheat and barley growing, sugar production, cotton growing, and others. All of them are organic substances, that is to say, they all contain carbon and hydrogen, as well as oxygen, nitrogen, and ash.

**Spent Tan** is the fibrous portion of oak bark that remains after the tan itself has been employed in the tanning industry. When perfectly dry it has a calorific value of about 6000 B. Th. units per pound, but it usually contains about 30 per cent. of moisture, and its calorific value thereby reduced to about 4000 B. Th. units per pound.

**Straw.**—The average composition of straw is as follows: carbon 36 per cent., hydrogen 5 per cent., oxygen 38 per cent., ash 5 per cent., a small quantity of nitrogen, and water about 16 per cent. The calorific value is in the neighbourhood of 5000 B. Th. units per pound when dry, but the net calorific value will not much exceed 4000 B. Th. units.

**Bagasse**, or as it is sometimes called, *Megasse*, is the husk of the sugar cane, from which the juice has been extracted. The usual process is, the canes are passed between rollers, the juice being squeezed out of them, as far as possible, and the husk, which consists

of woody fibre, is employed for raising steam. Bagasse has a two-fold value as a fuel. The woody fibre consists of carbon, hydrogen, etc., like the other substances that have been mentioned, and in addition, it is impossible with the methods employed, to extract all the juice of the sugar, and this has a calorific value of its own. From 8 to 15 per cent. of sugar remains in the bagasse after passing through the rolls, and its composition ranges from 40 to 50 per cent. of woody fibre, from 7 to 9 per cent. of sugar, and from 40 to 50 per cent. of moisture.

The calorific value of the woody fibre in the bagasse is in the neighbourhood of 8000 B. Th. units per pound of bagasse, and the calorific value of sugar and molasses is approximately 7000 B. Th. units per pound. The calorific value of bagasse therefore, apart from the presence of moisture, would be in the neighbourhood of 7500 B. Th. units per pound, but from this must be subtracted the heat required by the moisture, so that the net calorific value may be as low as 3750 B. Th. units. With excessive moisture, as where careless or inefficient milling rules, the calorific value of the bagasse will vary proportionately.

**Cotton.**—The stalks from the cotton trees have a calorific value of about 4000 B. Th. units when dry, any moisture that is present reducing the value, as already explained.

In America corn and maize have also been used as fuel in the outlying districts where these substances were very plentiful, and other fuel was not. The calorific value of corn is in the neighbourhood of 8000 B. Th. units.

Sawdust, dried manure, are also employed as fuel. It will be understood that special forms of furnace are required for burning these substances, in order that the proper quantity of air shall be delivered to them.

## Liquid Fuels

Petroleum, coal tar, water-gas tar, all have high calorific values, and are all employed for burning in boiler furnaces, to raise steam. Petroleum is known principally as the substance that is burned in oil lamps, and in oil engines, and in the form of a distillate in the engines employed for motor-cars. It is found in the liquid form in several parts of the world, in Russia and America principally, and it is also distilled from the shales that are found in Scotland and in other parts. The origin of petroleum is in dispute. One rather favourite theory is, that petroleum has been formed very much as coal has, but from marine plants. The composition of petroleum is similar to that of coal, but the carbon is less than in the anthracite forms of coal, while the hydrogen is very much greater, and the

oxygen very much less. The composition ranges from 80 to 87 per cent. of carbon, from 11·5 to 14 per cent. of hydrogen, and from 0 to 6 per cent. of oxygen. The specific gravity ranges from 0·786 to 0·938, and the calorific value from 18,000 to 22000 B. Th. units per pound. The petroleum which is found in the liquid form is usually reached by wells, sunk to the strata in which the petroleum is found, and from which it sometimes has to be pumped, and sometimes rises to the surface without pumping, owing to the pressure to which it is subject, just as water rises in some artesian wells. The oil is frequently diluted with water, and when sold, may contain any quantity from 1 to 50 per cent. At the oil wells, proper arrangements are made for separating the oil from the water, and best petroleum should not contain more than 1 per cent. of water. The same remarks that have been made with regard to the presence of moisture in wood and other fuels, apply equally to liquid fuels. Any water that is present, absorbs heat approximately in the ratio of 1200 B. Th. units for every pound of water.

The petroleums are divided into three groups, known respectively as the paraffin, asphalt, and olefine. The paraffin group are dark brown with a greenish tinge, and the oil is used principally for illumination. The asphalt group, found in California and Texas, vary in colour from reddish brown to jet black. The olefine group are found principally in Russia. The asphalt and olefine groups are used principally for fuel.

A gallon of petroleum weighs in the neighbourhood of 6½ lbs., the weight varying with the specific gravity of the substance. The petroleum, as it comes from the wells, is subject to a process of distillation, partly for the purpose of removing foreign matters, and partly to separate the various oils that are contained in the petroleum, and that are used for illuminating and other purposes, such as gasoline, benzine, and kerosene. These substances are formed into vapour at different temperatures, and hence can be separated from each other, and from the parent substance, by what is called fractional distillation, the different vapours, as they come away, being condensed in different vessels. It is the residuum, the substance remaining after the illuminating and other oils have been carried over, that is used for fuel; it is known sometimes as petroleum refuse.

## Flash Point and Ignition Point

There are two very important matters in connection with the handling of liquid fuels, the temperature at which the oil or fuel gives off an inflammable gas, and the temperature at which it ignites. The temperature at which an inflammable gas is given off

is known as the flash point, and the flash point is lower with the lighter oils—those whose specific gravity is low, and whose illuminating value is comparatively high—than with the oils and refuse of higher specific gravity.

The process of obtaining oil from the shales mentioned above, is very similar to that employed in separating the different oils found in the liquid petroleum. Shale is a substance somewhat similar in appearance to cannel coal. It is a solid, and it is distilled in vertical retorts, the products of distillation, the vapours which are formed, being condensed in the same manner as those from the liquid petroleum, and these being valuable for illuminating oils and for fuel.

### Gas Tar as Fuel

Another substance that is occasionally employed as fuel, is the tar that is a by-product in the generation of illuminating and other gases. When coal is distilled in the gas retorts for the production of illuminating gas, in addition to the gas itself, a product comes away, known generically as tar, from which the aniline dyes and other substances are afterwards produced. The tar is of too high a commercial value to be used as fuel, but it has its own calorific value, which is found from its composition. It contains approximately 89 per cent. of carbon, 5 per cent. of hydrogen, 4 per cent. of oxygen,  $\frac{1}{2}$  per cent. of sulphur, and a minute quantity of ash, and its calorific value is given as in the neighbourhood of 15,000 B. Th. units. Tar is also produced in the process of generation of the various producer gases, water gas, and others, and it is also present in blast furnace and coke oven gases. The tar is carefully separated from the illuminating gas before it is allowed to pass into the gas-holders for distribution to consumers, and the apparatus for its separation and for the purification of the gas forms a large portion of the plant at a modern gas works. Similarly the gas produced from gas producers is also separated from any tarry and other products that may be present, and for the reason that the gas engines in which producer and other gases are employed would soon have the working of their valves and cylinders seriously interfered with, if the tar was allowed to remain in the gas, as it would be deposited in valve passages on the inside of cylinders, and so on. The tar from gas producers and coke ovens, etc., has a slightly different position to that formed from illuminating gas, carbon being about 92 per cent., hydrogen 6 per cent., nitrogen 0.1 per cent., oxygen 0.7 per cent., sulphur 0.3 per cent., and a minute quantity of ash. The calorific value is given as about 17,000 B. Th. units.



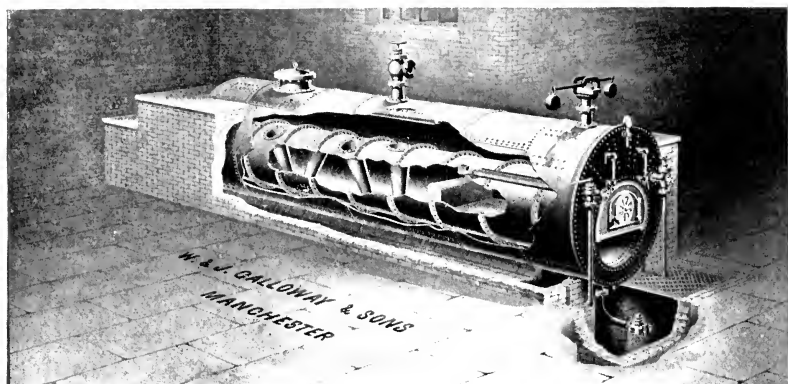

PLATE 1A.—Galloway Cornish boiler, with cone tubes. The single central inside flue and the outside brickwork flues are shown.

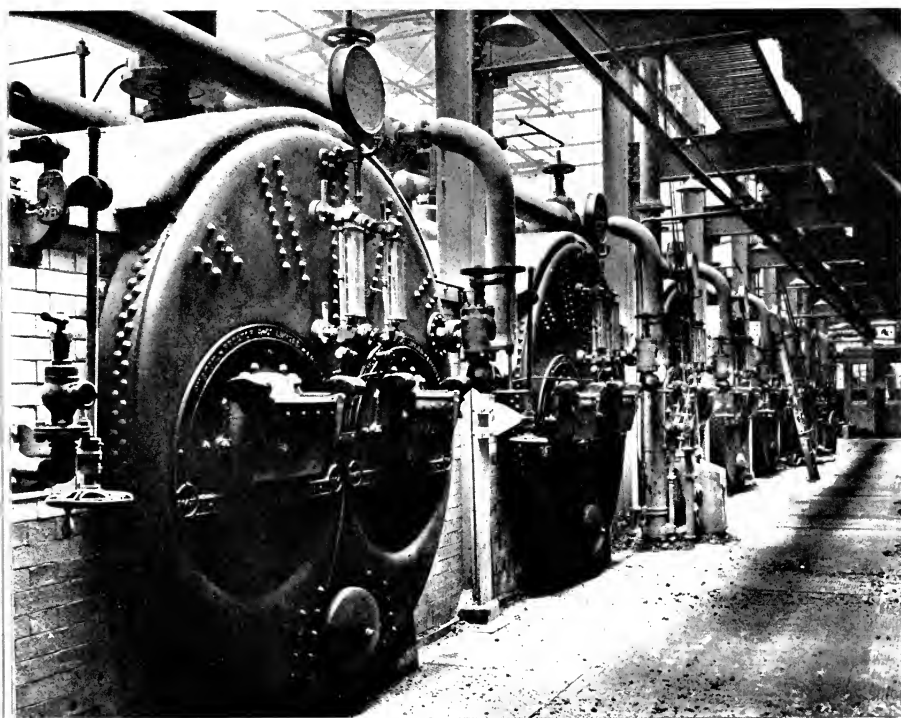

PLATE 1B.—Battery of Lancashire boilers, by Messrs. Ruston, Proctor & Co.  
[To face p. 48.]



## Burning Liquid Fuels

Special arrangements are necessary to enable liquid fuels to be burned, whether in the furnace of a boiler, or in the cylinder of an internal combustion engine. It is really the vapour which comes away from the surface of any oil, that is used either for heating or illuminating purposes, that is burned. It is not the oil itself, until it has been converted into vapour, and the apparatus required for enabling liquid fuel to be burned consists of arrangements for either breaking it up, or raising its temperature, so that it becomes vapour. Broadly, there are two methods of handling liquid fuel—by breaking it up into a very fine spray, and in that form mixing it with the air, each particle of the liquid seizing upon the quantity of oxygen it requires from the atmosphere surrounding it; and by raising the temperature of a certain portion of it to that at which it gives off vapour, the vapour as it comes away passing into a current of air.

The different methods employed will be described in connection with the boiler furnaces. It will be sufficient to mention here that all liquid fuels, oils and refuse of oils, and tars, require to be handled in this way.

## Gaseous Fuel

There are several forms of gaseous fuel employed for firing boilers. Ordinary illuminating gas may be employed for the purpose, if it is convenient in other ways, but it is usually more economical to burn it in the cylinder of an internal combustion engine. It should be mentioned incidentally that this remark applies to all gaseous fuels, but as the object of this book is to show all possible methods of generating steam, and utilizing it for power, the gaseous fuels used in boiler furnaces must be dealt with.

In addition to the ordinary illuminating gas, there are the producer gas referred to below, blast-furnace gas, coke-oven gas, and what is termed natural gas.

## Producer Gas

The producer gases are all made on somewhat the same lines. Either steam, or steam and air, are forced through a mass of incandescent fuel, preferably anthracite coal or coke, though bituminous coals are also employed for the purpose. The high temperature at which the fuel is maintained decomposes the water into its constituents, oxygen and hydrogen, the carbon of the fuel combining

with both of them, and with the oxygen of the atmosphere, if the air is employed as well, the result being the formation of a gas largely consisting of carbonic oxide. The composition of producer gas varies with the different methods of production, but it will be approximately as follows: carbonic oxide 24 per cent., hydrogen 8 per cent., carburetted hydrogen 2 per cent., carbonic acid 4 per cent., nitrogen 61 per cent., and a small quantity of oxygen. It is usual to express the calorific value of gaseous fuel in terms per cubic foot of the gas. The calorific value of producer gas ranges from 120 to 200 B. Th. units per cubic foot.

The gas produced by suction gas producers is not intended to be used with boiler firing, and cannot be employed unless special arrangements are made to imitate the sucking action of the internal combustion engines.

## Blast Furnace Gas

Blast furnace gas is formed in the process of smelting iron. What is known as pig iron, from which wrought iron, steel, etc., is afterwards made, is produced in the blast furnace, a large structure nearly cylindrical, its internal section being partly that of an inverted cone, and having a grate on the bottom of the cone, on which a fire is lighted. The furnace is fed with the iron ore to be smelted, which consists largely of iron and oxygen. A quantity of limestone is employed as a flux to enable the smelted iron to run freely, and a quantity of coke, whose combustion supplies the heat necessary for the melting of the iron and its separation from the oxygen and impurities. A powerful current of air is constantly forced through the furnace by means of powerful engines, the current of air being known as the blast, and hence the furnace being called a blast furnace. The carbon in the coke unites with the oxygen of the air in the blast, and also with some of the oxygen which is driven off from the iron ore, the result being the formation of a gas containing a large quantity of carbonic oxide, the gas coming away from the top of the furnace. A portion of the gas is employed in heating the air which is driven into the furnace, usually about half the total quantity of gas delivered by the furnace, but the remainder is available for use either in internal combustion engines, or for combustion in the furnaces of steam boilers. It is employed very largely at iron works for raising steam to drive the blast engine, though in later practice the blast engine is an internal combustion engine, and the gas is consumed in its cylinder. There is usually some gas remaining after the heating stoves for the blast and the requirements of the blast engine have been satisfied, that can be employed, if desired, for raising steam. The composition of blast furnace gas varies again, carbonic

oxide being the important constituent, and the one upon which the heating value of the gas as a fuel depends. The composition is as follows: carbonic oxide, from 24 to 34 per cent.; carbonic acid, from 1 to 12 per cent.; nitrogen, from 57 to 64 per cent.; hydrogen, from 0 to 5 per cent.; hydrocarbons, from 1 per cent. downwards. Its calorific value is from 120 to 150 B. Th. units per foot.

## Coke-oven Gas

Coke is made very largely at collieries where coking coals are produced, the process being very similar in many respects to that for producing ordinary illuminating gas. The coke is produced in coke ovens of various forms, from small coal that has been previously washed to cleanse it from ash, sulphur, and other impurities. The oven is filled with the small coal and then closed up, the mass being then heated, either by some of the gas produced from the coke itself passing through channels provided for it surrounding the oven, or by the heat liberated by the burning of the coal itself in the oven. In either case the production of the coke consists in driving off the volatile matter, the gases that are present in the coal, leaving a mass of nearly pure carbon. In the older forms of coke ovens, some of which may still be seen in various parts of the kingdom, and may be known by the flames they emit from the tops of the furnaces, the gas was allowed to pass away into the atmosphere. In the modern form of coke oven part of the gas is employed, as explained above, in heating the oven, and the remainder, usually about half that generated, is available for use in the furnaces of boilers or in the cylinders of internal combustion engines, or wherever heat is required. The calorific value of coke-oven gas is about 400 B. Th. units per cubic foot.

## Natural Gas

By natural gas is understood the gas that is found free in the ground, not much in this country, but well known and largely used in America, and that has been produced by natural forces, very much in the same manner as coal and petroleum have been produced. Possibly the natural gas may be emanations from the coal in process of natural distillation. In America natural gas is found at various depths below the surface, is pumped from wells to the points where it is to be employed, and is used there in the same manner as ordinary illuminating gas would be employed. Its composition varies with the locality, and its calorific value necessarily varies with its composition. One composition given is as follows:

marsh gas,  $\text{CH}_4$ , which is the gas found in coal mines, 72.15 per cent. ; olefiant gas,  $\text{C}_2\text{H}_4$ , which is one of the principal gases in ordinary illuminating gas, 0.66 per cent. ; ethane, another gas of the same series,  $\text{C}_2\text{H}_6$ , 4 per cent. ; carbonic oxide, 1 per cent. ; carbonic acid, 0.3 per cent. ; oxygen, 0.4 per cent. Its calorific value is given as over 900 B. Th. units per cubic foot.

## The Gases found in Collieries

There is another source of fuel that at present is both a nuisance and a danger, but which in time to come will probably be employed as a source of power, viz. the gas which is found in the coal measures, and which has been produced by the distillation of the organic substances contained in the plants from which the coal was formed, during the ages since the plants were buried. The gas consists almost entirely of that known as marsh gas, having the chemical formula  $\text{CH}_4$ . It is largely imprisoned in the pores of the coal itself, it is thought in the liquid, and possibly even in the solid, form, and under very great pressure, with the result that it comes away freely as the coal is worked and the pressure to which it is subject is reduced. One great reservoir of this form of natural gas is found in the coal fields of South Wales in the faults in the strata. It was explained, in dealing with the production of coal, that the coal seams or coal measures had been subject to great disturbing influences from upheavals of the strata, from the same causes that produce earthquakes and the eruptions of volcanos. The result has been that the strata has been broken and that the edges of the coal seams have been presented to the edges of other rocks, a very fine capillary space being present between them, and in this space the gas from the coal seam is apparently stored. On several of the colliery pit banks in South Wales may be seen jets of gas burning day and night, something on the lines of the flares that butchers favour on their stalls on Saturday nights, the gas issuing from the end of a pipe. These flames are produced by the gas carried by means of these pipes from the faults mentioned above, and it is merely a step from burning them wastefully, to storing them and using them for power. In one colliery in South Wales they have been used for some time, after scrubbing, for illuminating purposes.

## CHAPTER II

### BOILERS

#### The Steam Boiler

THE steam boiler is an apparatus designed for the conversion of water into steam by the aid of heat liberated by the combustion of one of the fuels that have been enumerated in the previous chapter. It is made in a very large variety of forms, all designed with the view of increasing its efficiency, or increasing the real efficiency of the steam plant as a whole, by decreasing the repairs and the attendants' bill. All of them must contain a space in which water is carried, and to which a continuous supply of water can be added as that present is converted into steam. They must also contain a space in which the steam that is generated can be stored until it is drawn away to the engines or turbines that use it. They must also have some arrangement for the burning of the fuel that is to be employed as the source of heat. The question of economical consumption of the fuel, and of the utilization of the largest proportion of the heat liberated by the combustion of the fuel, is responsible for the principal designs of the various boilers. When we examine the question of the combustion of any fuel—say, for example, that of coal in our domestic grates—we find that it is exceedingly wasteful. As explained in the first chapter, heat is liberated by the combination, principally of the carbon and hydrogen in the fuel, with the oxygen of the atmosphere that is supplied to the fuel, the mass of fuel and the air supplied to it being converted nearly all into gas, the more nearly the whole can be converted into gas the more economical being the process of combustion, and the more easily the furnaces in which the fuel is burned being worked. But it follows that the heat liberated by the burning fuel is almost entirely delivered to the gases that are formed from it and those of the air that are present but are not in combination; and in the case of the domestic fire-grate, as these gases pass directly up the chimney, the major portion of the heat liberated passes there also, only a small quantity of the

total heat passing out into the room, by radiation from the glowing coals, or from the flames that are produced as the coal burns. The enormous waste involved in the burning of coal in the ordinary fire-grate will be appreciated when it is pointed out that the combustion of 1 oz. of coal, measuring about 2 cubic inches, should be sufficient to raise half a gallon of water to boiling-point or to raise the temperature of the air of a room of 4000 cubic feet  $10^{\circ}$  F. We know perfectly well from our experience that the combustion of the ounce of coal, consisting of a small knob that we throw on the fire, will do nothing of the kind, and the reason is as stated above. In early forms of boilers something of the same kind of waste took place, but successive advances have been made, the object of all of which has been to utilize, as far as possible, the whole of the heat delivered to the gases. For this purpose the hot gases are not allowed to pass immediately to the chimney, but are taken to it, in all forms of boiler, by a more or less circuitous path, in the course of which they pass over metal surfaces, on the other side of which are placed bodies of water, to which the heat is transmitted, and from which steam is formed.

### Circulation in Boilers

Another important matter in connection with the heating of water, is that of the circulation of the water within the boiler. It was pointed out in the first chapter, that when liquids or gases are heated they expand, a given volume in contact with the heating surface, becoming lighter than the surrounding equivalent volumes, is pushed away from the heating surface, other portions of the liquid or the gas taking their places, and convection currents, as they are called, being thereby set up, enabling the mass of water or gas to be heated all over. In addition, it may be pointed out that when water is in contact with a metallic surface, on the other side of which is a source of heat, minute globules are formed on the heated surface, which, unless they are enabled to get away by the action of the convection currents mentioned, resist the passage of the heat from the metallic surface to the water beyond them. Hence it is of great importance that the water in a boiler should be kept continually in motion, and this requirement has caused the development of some of the designs of boilers that will be described. One point that had better be mentioned, as it is a very striking one, is that if heat is delivered to the whole body of the water, or to the upper portions, very little circulation takes place, and water being a poor conductor of heat when not assisted by convection currents, the heat does not easily reach the lower portions of the mass of water, and any arrangement of the kind must necessarily be very wasteful. This applies,



to a smaller extent, to heat applied to the sides of a mass of water. The best position for any source of heat applied to raising steam from water, is on the lower part of the body of water. The domestic tea kettle is the most striking instance of this. On the other hand, as will be explained, the structural requirements of the vessel, or groups of vessels, of which boilers are constructed, require the presence of water in certain parts of the boiler, where circulation is not easy. Instances of this are, the lower part of the Lancashire boiler below the furnace, and the back of the marine boiler, as used on board ship. These points will be explained more fully when describing the different boilers, but it may be mentioned here, that one of the most important matters in connection with the construction of a steam boiler, is to arrange for the expansions and contractions that take place in the metals of which the boiler is composed, the expansions being very great with the very high temperatures present in some parts of the boiler, and also to provide for the differences in expansion of different parts of the boiler, owing to the different temperatures to which they are exposed. Another important point in all boilers, is to ensure that water shall be present on the opposite sides of the surfaces that are exposed to the highest temperatures.

## Fire-tube Boilers

The earliest forms of boiler used in modern times were those now known as fire-tube, to distinguish them from the water-tube boilers that have come so largely into use during recent years. Fire-tube boilers may be divided into Cornish boilers, Lancashire boilers, and multitubular boilers, each of these forms being designed with the object of providing a path for the hot gases through them, of such a nature that the heat can be easily extracted from the gases, and delivered to the water, on their way to the chimney. The Cornish and Lancashire boilers are very similar in construction up to a certain point. In each there is a cylindrical shell forming a receptacle for the water and the steam. In the Cornish boiler a portion of the cylinder is taken for the provision of the space required for the furnace, and for the flue through which the furnace gases are to pass on their way to the chimney, and through which they are to deliver their heat to the water in the boiler. In the Lancashire boiler there are two such spaces taken out of the cylindrical vessel, for two furnaces and two flues. In both the Cornish and Lancashire boilers the spaces taken for the furnaces and flues are cylindrical, that for the Cornish boiler in the earlier forms being roughly double that of one of the Lancashire. In both forms of boilers the cylinders forming the flues have the

furnaces consisting of grate bars of various forms, fixed at one end, the grate bars being placed a little above the middle of the flue cylinder, and sloping slightly towards the other end, as shown in Fig. 5. At the end of the grate bars a fire-brick bridge is usually built, as shown in the figure, which becomes white hot from the passage of the hot gases over it, and assists in ensuring the complete combustion of the fuel. The hot gases formed by the combustion of the fuel and the air with which it combines, pass from the fire-grate over the bridge and through the flues in both the Cornish and Lancashire boilers, to the opposite end of the boiler, and from there are

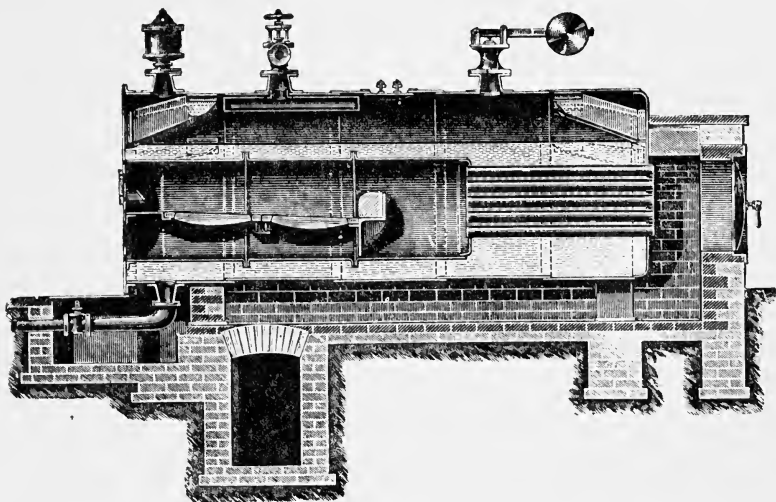

FIG. 5.—Sectional Drawing of internally fired "Cornish" and Multitubular Boiler, made by Messrs. Marshall. The Hot Gases pass from the Central Boiler Flue through the Tubes at the back, thence through the Under and Side Flues to the Chimney. A Section of the Furnace is shown, at the front of the Boiler, and it will be noticed how the Fire-bars slope inwards towards the Bridge.

usually brought under the lower surface of the boiler to the furnace end, and when a little way from the front are divided, half of the gases passing on each side of the outer shell of the boiler to the back end again, where they pass to the chimney. As shown in Figs. 5 and 6, and Plates 2A, 2B, and 2C, fire-brick flues are built round the outside of both Cornish and Lancashire boilers, the boiler shells being held between the edges of a row of fire bricks, and the remainder of the bricks being arranged to provide the external flues, through which the hot gases pass as described. In both Lancashire and Cornish boilers, it will be seen the hot gases pass three times from end to end of the boiler, from the furnace to

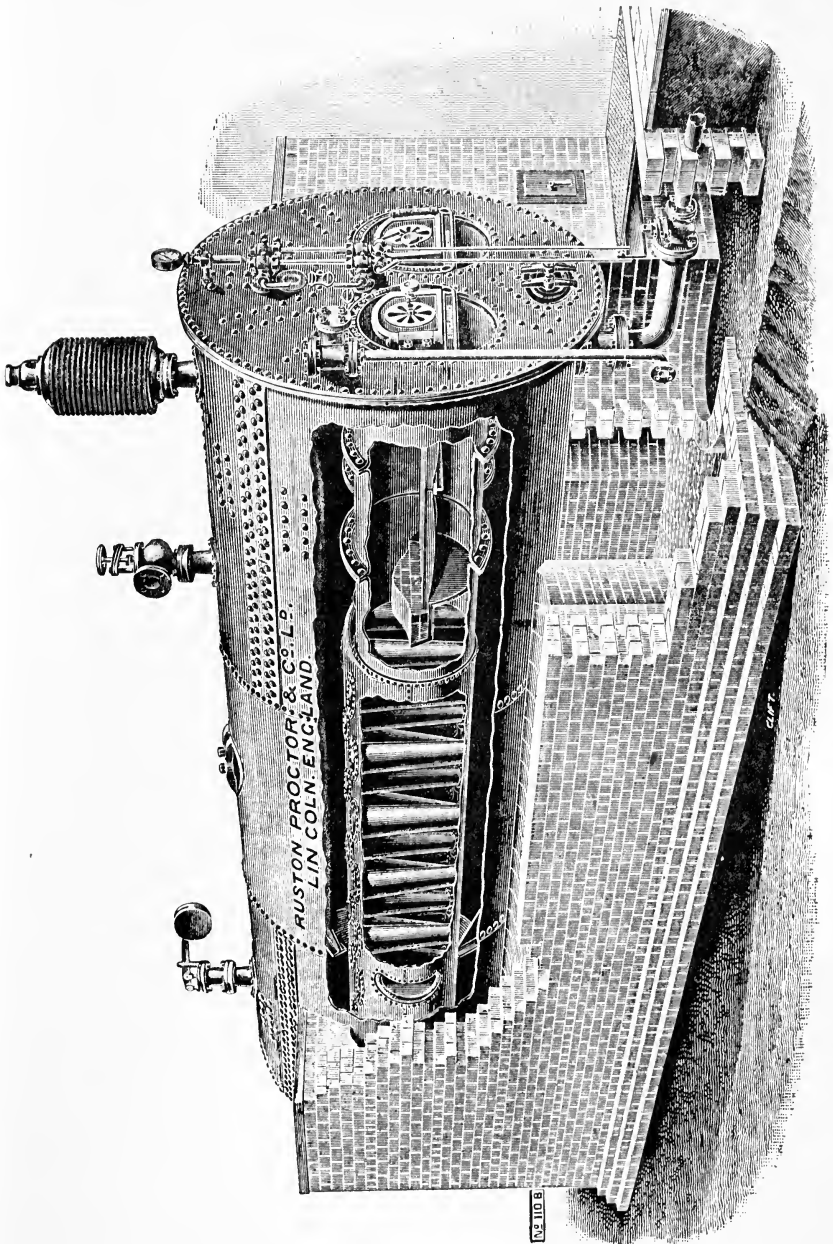

FIG. 6.—Sectional Drawing of Lancashire Boiler with Cone Tubes. The Brickwork is removed to show the Side and Under Flues.

the back end, from the back end to the front end under the boiler, and from the front end to the back end again by way of the side flues. It will be understood that the cylindrical vessels forming both the Cornish and Lancashire boilers, contain water up to a certain level, usually several inches above the tops of the flues, this being a very important point. The crowns of the furnaces in particular, as the upper portion of the cylinders forming the furnaces and flues are called, should always have a substantial quantity of water lying on them, so that the crowns themselves should not reach a dangerous temperature. The water lying on the furnace crowns carries off the heat as it is delivered to the furnace. Water lies all round the cylindrical flues, and it lies on the inside of the boiler where the bottom and side flues are built, and therefore the hot gases passing through the outside flues are able to transmit the heat they possess, through the outer metal surfaces to the water on the inside.

It will be noticed from the above, and it will be seen more clearly from the Figs. and Plates mentioned, that there is one part of the cylinders of both Cornish and Lancashire boilers over which the hot gases do not pass, viz. the segment forming the upper portion. It is that portion in which the steam generated is contained, and it is a rule in boiler construction, and boiler working, that the steam space is not to be exposed to the hot gases, and vessels containing steam are not to be exposed to heat, except in the case of the special arrangements, described later, for superheating the steam. This upper portion of the boiler should be covered with a thermal insulator, so that the heat present in the steam, which is communicated to the boiler shell, should not be lost by radiation, as it is if no protection is provided for it. The importance of covering this space with a thermal insulator, and of covering steam pipes, as will be explained later, will be seen from the fact that each square foot of boiler or pipe surface radiates when unprotected by thermal insulators, 2·812 B. Th. units per hour, for every degree difference of temperature between itself and the temperature of the surrounding atmosphere (Siebel). Taking the temperature of the atmosphere in this country as averaging 60° F., with steam of 150 lbs. gauge pressure, this would mean a radiation of 300 times, 2·812 B. Th. units for each square foot of surface exposed; or, again, taking the case of a Lancashire boiler 8 feet in diameter, and 30 feet long, the area exposed to radiation would be about 200 square feet, and this would mean, with average temperatures, a loss by radiation of 168,720 B. Th. units per hour, and with some winter temperatures, of much more. From Fig. 5, it will be seen that in the water lying on top of the furnace crowns receives the largest amount of heat, that lying on top of the flues beyond receiving the next largest, that by the side of the furnaces

and flues the next, while the remainder of the water in the boiler receives gradually less and less heat, as the temperature of the gases passing over the metal separating it from them decreases. It will be noticed also that portions of the water in the boiler are placed between two heating surfaces, that at the sides and between the flues and furnaces. But while the water at the bottom of the boiler is also between the bottom of the flues and the lower surface of the boiler, and is exposed to the hot gases as they pass from the back of the flues to the front, it receives very little heat from the furnaces and main flues. From the figures it will be seen that it can receive practically no heat from the furnaces, because the ash-pit, which forms about half of the area of the furnace, and which is occupied practically by hot air only, is interposed between the fire-bars on which the burning fuel rests, and the bottom of the furnace. In addition to this, the natural tendency of hot fluids, using the term in its scientific sense to mean liquids and gases, to rise when heated, keeps the hot gases in the flues to their upper portions, and therefore very little heat passes from them to the water below. As will be seen later on, this is not altogether an unmixed evil. As explained in the first chapter, the water available for boilers is only pure when it is evaporated specially for the purpose, or when the condensed exhaust steam is used again, and only then after it has been subjected to a process of purification. Hence it is of importance that there should be some part of the boiler where the foreign bodies present in the water can deposit, with as little harm as possible, and in the Lancashire and Cornish boilers the bottom of the boiler is the place where foreign matter falls. A mud hole, as it is called, as shown in Figs. 5 and 6, and Plates 1A, 2A, 2B, and 2C, and sometimes a mud drum, is fixed at a convenient part of the bottom of the boiler, usually at the back end, for the purpose of getting rid of all these foreign substances, the deposit being periodically blown out by the scum cock provided for the purpose.

On the other hand, the question of the circulation in the boiler is a very important one, and for that reason a number of adjuncts have been added to boiler plant, all aiming at carrying the water from the lower part of the boiler to the upper part, and that above to the lower part, the object of this being the more efficient working of the boiler, and the more even distribution of temperatures.

### **The Galloway Cone Tubes**

One of the earliest methods of increasing the circulation of the water in the boiler, and at the same time of increasing the extent of metal-heating surface in the boiler, was the Galloway tube.

It will have been noticed, in the description given above of the

path of the gases generated in the boiler furnace, that in both Lancashire and Cornish boilers one object endeavoured to be attained was, the exposure of the largest water surface to metal plates, on the other side of which the hot furnace gases were passing, every part of the boiler in which water is present, it will be remembered, being traversed by the hot gases before finally passing to the chimney. One advantage possessed by the Lancashire boiler over the Cornish boiler is, the fact that practically double the heating surface, as it is termed, the hot metal surface against which water presses, is present. The Galloway tube, which was introduced first as a simple cylindrical tube, and afterwards as one having the shape of a frustrum of a cone, was brought out as far back as 1849. It was made in conical form in 1851, and after passing through the usual developments, has finally settled down to the form at present employed, in which the diameter of the upper end is twice that of the smaller end, the figures being usually  $10\frac{1}{2}$  inches diameter at the top and  $5\frac{1}{2}$  inches at the bottom, and with very small flues 9 inches at the top and  $4\frac{1}{2}$  inches on the bottom. The Galloway cone tubes are now employed in large numbers of both Cornish and Lancashire boilers, and they are fixed in the flues beyond the furnace in varying numbers, according to the design of the different makers. Fig. 6, and Plates 1A, 2A, 2B and 3A, show the arrangement of the ordinary Cornish and Lancashire boilers, with the cone tubes. It will be understood from what has been said, that the cone tubes increase the space occupied by the water with any given size of boiler, and they also increase the metal surface exposed to the hot gases, having water on the other side. The presence of the cone tubes also furnishes paths for the water to pass from the bottom to the top, and *vice versa*, and so considerably aids the circulation, thereby increasing the efficiency of the boiler as a whole. In addition to this, the presence of the cone tubes materially strengthens the boiler flues. It will be understood from the sectional drawings in Figs. 5 and 6, and Plates 1A, 1B, 2A, 2B and 2C, that in both the Cornish and Lancashire boilers the outside vessel consists of a cylinder of a certain length, usually with flat ends, and carrying the one or two cylindrical tubes suspended inside the outer shell, and supported by the ends, and by the buoyancy of the water. Hence anything which tends to strengthen the flue as a whole, to enable it to resist the forces tending to its deformation, such as the heat from the hot gases, etc., tends to lengthen the life of the boiler, and to reduce the repairs bill.

## The Construction of Lancashire and Cornish Boilers

The construction of Lancashire and Cornish boilers is carried out on almost identical lines, the differences in the boilers being those

stated, the one having only one flue against the other's two. For the manufacture of all classes of boilers, it should be mentioned, elaborate and very powerful machinery has been worked out, to enable manufacturers to handle the large steel and iron plates dealt with, and to save labour in the manufacture. All classes of Lancashire and Cornish boilers have their shells made of Siemens Martin open-hearth steel, having a tensile strength of from 26 to 30 tons to the square inch, and one of the first things the boiler-maker sees to is that the steel plates that are delivered to him comply with this requirement, and also have a certain elasticity and ductility. Samples of the plates taken at random are tested in machines specially designed for the purpose, for their breaking strain and the elongation. The breaking strain must be from 26 to 30 tons to the square inch, and the elongation must be 20 per cent. in a length of 10 inches, without breaking.

The boiler shells are built up of a succession of circular rings, as will be seen from an inspection of a complete Lancashire boiler, as shown in Plate 1A, the size of each ring depending upon the diameter of the finished boiler, and the number of rings upon the length of the boiler. Each ring is made from a flat plate, which has had its edges planed to a bevel, and is bent round to a circle, usually by vertical plate-bending rolls. The two ends of the plate are united together to form the ring, either by lap joints or by butt joints, the latter being the more frequent arrangement. In the lap joint one edge of the plate is lapped over the other, and the two are bolted together by rivets. In the butt joint the two edges are butted together; the bevels, which are fullered by a special tool to enable them to bed well against each other, are brought together, and two short plates, one inside and one outside, are bolted across the butt by rivets. In days gone by it was common to punch holes in the steel and iron plates that are employed in boiler-making, with the twofold result that the holes were often not exactly in the position they should be, and special tools had to be employed to work the holes opposite each other, and to get the rivets in place, and a process of caulking the seam had to be resorted to after the boiler was complete. Further, it has been shown that the process of punching the plate deteriorates the substance of which it is composed, and hence the practice now is, that all holes required for rivets or other purposes in any part of the boiler shell, are either drilled or turned by proper machinery, that does not injure the material, and that will work truly in the modern sense. For the rings of boiler shells, it is usual to have a number of drills in one frame, standing vertically one above the other, and drilling several holes at the same time, this ensuring that the holes shall be truly in line, and enabling the work to be done rapidly. The ring to be drilled is mounted in a vertical

position, in a frame provided for it, which holds it rigidly, the drilling machines then being brought into position, and drilling the holes as described. Care is taken to break joint, as it is termed, in the successive longitudinal seams of the different rings. The seam of each ring comes opposite a space in the ring on each side of it, where there is no joint.

The ends of Lancashire and Cornish boilers are made of masses of sheet steel, of the same tensile strength as that from which the rings are made. They are turned to a complete circle, and at the same time the one or two holes required for the one or two flues are bored out of them, in the proper positions, by tools arranged for the purpose. The end plates are also drilled in very much the same manner as the shells of which the ring is composed, and they are secured to the end rings of the shell, either by flanges formed on the plate themselves, or by angle rings, and in other ways. The end plates are further held to the end rings of the shells by what are known as gusset stays, practically angle pieces secured to the end plates, and to the inside of the boiler shells.

In some forms of Lancashire and Cornish boilers the ends are made either egg-shaped or dish-shape, the object in these forms being the avoidance of the necessity of the gusset stays. With these forms the ends of the boilers are made just the size to fit inside the end ring of the shell, the two being then drilled and riveted together.

Riveting is nearly always done by hydraulic pressure. The operation requires two men, one standing inside the boiler to be riveted, and manipulating what is called a "dolly," or holder-up, which is practically a chock to take the thrust of the rivet. The rivet is placed in the hole, the hydraulic riveter brought against it, and its end expanded over the hole, in the same manner as cleating, the arrangement making a very sound and economical joint.

Cornish boilers are made usually for lower powers than Lancashire boilers, and in smaller sizes. The Cornish boiler is made from 3 feet 6 inches in diameter up to 7 feet in diameter, and from 9 feet in length up to 30 feet, the evaporative power ranging from 700 lbs. of water per hour up to 3500. The Lancashire boiler is made from 5 feet 6 inches in diameter up to 9 feet, and from 14 feet in length up to 32 feet.

The single flue of the Cornish boiler was originally larger than either of the two flues of the Lancashire boiler, but modern practice has settled down to flues of about the same size, and though they vary with different makers, they are approximately half the diameter of the boiler, the flues of the larger sizes of Lancashire boilers being rather less than this.

The Lancashire boilers evaporate from 1600 lbs. to 9000 lbs. of water per hour.



Cornish boilers are occasionally made with their flues eccentric to the outer shell.

## Lancashire and Cornish Boiler Flues

The Lancashire and Cornish boiler flues are constructed in several different ways. The simplest arrangement is, the flue is formed of successive lengths of rings, of the diameter the flue is to take. The rings are formed of mild steel plates, bent to the form of a cylinder, by bending rolls, in the same manner as described for the boiler shell, the ends of the plate being usually welded together. In some forms of boiler, and by some makers, the ends of the plates forming the rings, are drilled and riveted together, in the same manner as described for the boiler shell, but welding is far more common. The successive lengths are connected together in the simple form of flue, by flanged joints. A flange is formed in the end of each ring of the flue, and out of the ring itself, by a special flanging machine, the two flanges of successive rings being drilled and riveted together. The

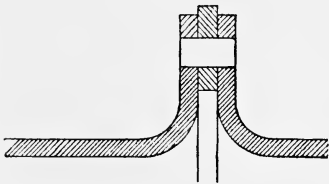

FIG. 7.—Section of the Adamson original Flange Seam for Lancashire Boiler Flues.

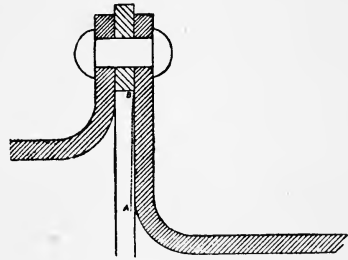

FIG. 8.—Section of the Adamson absorber Flange Seam for Lancashire Boiler Flues.

simple form of flue has, however, been departed from by many manufacturers, for the reason that the simple riveted flanged joint frequently gave way. One method that has been adopted is what is known as the Adamson joint, in which an additional ring is placed between the two flanges, as shown in Fig. 7, the whole being riveted together. Messrs. Daniel Adamson & Son have also since introduced another form of joint for the sections of boiler furnaces and flues. It is shown in Figs. 8 and 9, and is claimed to give increased strength and increased heating surface, and to automatically take up its own expansion and contraction with heating and cooling. As will be seen from Figs. 8 and 9, the difference between the new form of joint, named by the firm the "Adamson absorber flange seam" is, the successive rings of which the flue is built up are of different

diameters, this it is claimed giving the expansibility required. Another method of jointing the successive rings of the flues has been introduced by Messrs. Davey, Paxman & Co. One end of each of the sections is expanded by special tools, to a certain diameter,

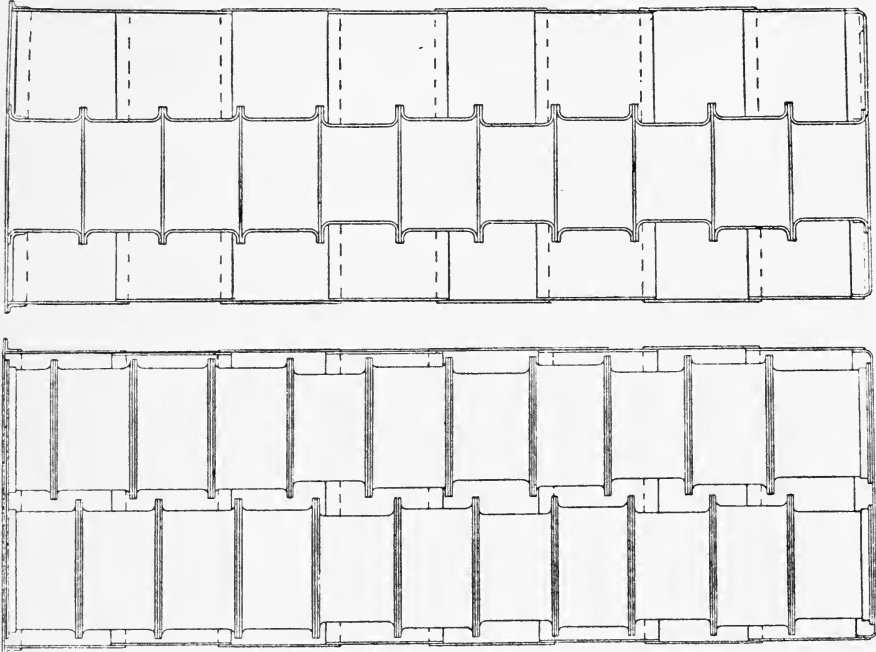

FIG. 9.—Sectional Elevation and Plan of a Lancashire Boiler, having its Flues fitted with Adamson's Absorber Flange.

and the end which is to unite with it of the next flue, is also expanded to a certain extent, but to a diameter that will enable it to just fit inside the end of the next section it is to engage with. The two flanges, when fitted together, are drilled by special drilling machines, and are then riveted by hydraulic rivets. It is claimed by Messrs. Davey, Paxman, that this arrangement provides for the expansion and contraction in the same manner as the Adamson joint.

### Corrugated Flues and Furnaces

Another form of furnace and flue that is made by several firms, is that known as the corrugated flue. As its name implies, the flue is built up of a succession of rings, as in the ordinary flue, but the rings are of the corrugated form. There are two forms of the

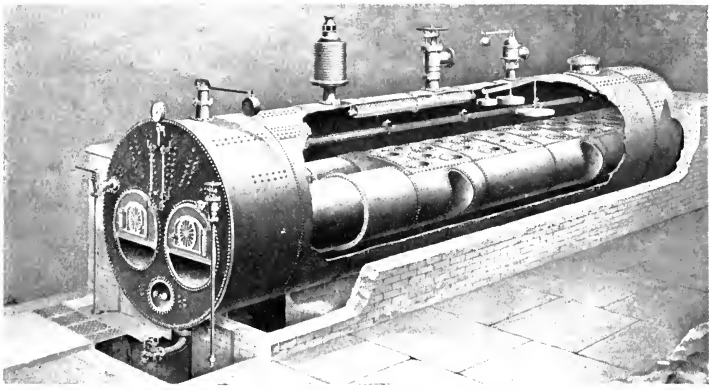

PLATE 2A.—Galloway Lancashire boiler, showing the cone tubes, and the special arrangement of the two flues behind adopted by Messrs. Galloway, also the pockets in the sides of the flues.

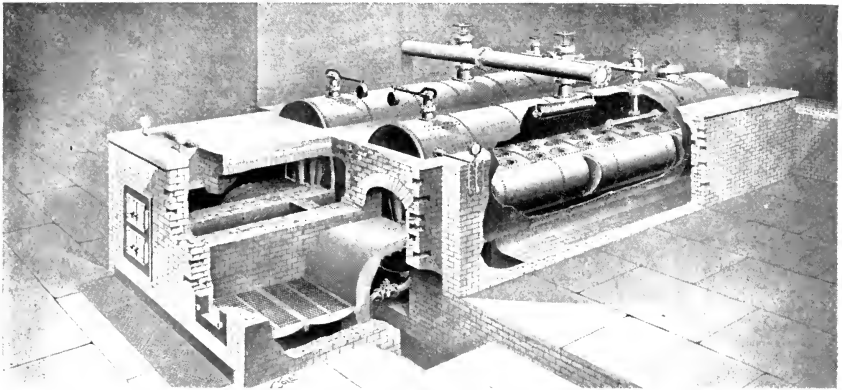

PLATE 2B.—Battery of Galloway Lancashire boilers, adopted for burning low grade fuels. The furnace is shown in front, with a connection to the boiler flues. The side flues and bottom flues are also shown.

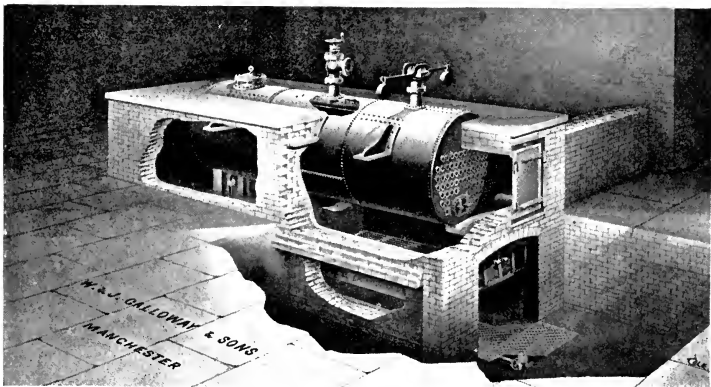

PLATE 2C.—Galloway multitubular boiler, with external firing, showing the furnace and the side flues. [To face p. 64.]



corrugated flue on the market. In the earlier form each successive ring is merely corrugated, very much on the lines of the well-known corrugated iron plates that are employed for building, etc. In later patterns the corrugation has taken a special form, in which there are ridges at definite distances along the length of the furnace, separated by valleys that are almost level, or only slightly raised in the centre. The object of the corrugated flue is to give greater strength to resist the pressures to which the flues and furnaces are subject. In some of the early furnaces that were made without any protection whatever, the furnace collapsed in places, owing to the extreme pressure brought to bear on it by the water and the steam above it. In addition to this, it often happens that there is a deposit from the water employed in the boiler on the top of the furnace crown, and this, especially when the deposit is of oil, such as is frequently brought over from the engine through the condenser, is such that a resistance is set up to the passage of heat from the burning fuel to the water lying on the top of the furnace, the result being that the crown of the furnace itself is raised to a high temperature, its tensile strength being then considerably reduced, and collapse resulting. The forms described give very much greater strength, it is claimed, to resist the pressure mentioned, and in addition they tend to reduce the tendency of the oil and other matters to deposit.

These forms of furnaces are made by the Leeds Forge Company, under the name of the Morrison Suspension Furnace, and one form of their furnace is arranged to be withdrawn from a marine boiler without dismantling the boiler itself. Messrs. John Brown & Co. also make two forms of the furnace, one of which they have named their Improved Furnace, and the other the Cambered Furnace, the difference between the two being the arrangement of the corrugations. Messrs. Deighton & Co. also make two forms, one in which the corrugations are simply hills and valleys, and the other in which the space between the hills is also slightly corrugated.

All of these firms have had tests carried out to meet the Board of Trade, Lloyds, and the Bureau Veritas requirements for furnaces that are employed on board ship, and the following formulæ are given for the working pressures for the different forms of corrugated furnaces, that is to say, the working pressure of the boiler to which the furnaces are applied.

The formulæ are as follows:—

$$\text{For the Board of Trade, W.P.} = \frac{14,000 \times T}{D}$$

$$\text{For Lloyds and the Bureau Veritas, W.P.} = \frac{1259 \times (T - 2)}{D}$$

$$\text{The British Corporation, W.P.} = \frac{1160 \times (T - 2)}{D}$$

TABLE XIII.

M	WORKING PRESSURES IN POUNDS PER SQUARE INCH.										M		
	3 in. 8 thick.	13 in. 32 thick.	7 in. 16 thick.	15 in. 32 thick.	1 in. 2 thick.	17 in. 32 thick.	9 in. 16 thick.	19 in. 32 thick.	5 in. 8 thick.	Least diameter of furnace inside corrugations.			
	* Lloyds B.of T. B.V.	* Lloyds B.of T. B.V.	* Lloyds B.of T. B.V.	* Lloyds B.of T. B.V.	* Lloyds B.of T. B.V.	* Lloyds B.of T. B.V.	* Lloyds B.of T. B.V.	* Lloyds B.of T. B.V.	* Lloyds B.of T. B.V.	* Lloyds B.of T. B.V.	† Lloyds B.of T. B.V.	† Lloyds B.of T. B.V.	Ft. Ins. 2 6
2 7	171	185	167	204	226	239	241	253	259	266	278	296	2 6
2 8	165	179	162	198	219	232	234	245	252	258	270	288	2 7
2 9	160	173	157	192	212	225	227	238	245	250	262	280	2 8
2 10	156	168	153	187	206	218	221	231	238	243	255	272	2 9
2 11	151	163	149	182	200	212	215	224	232	236	248	265	2 10
3 0	147	159	145	178	194	206	210	218	226	230	242	258	2 11
3 1	143	155	142	173	189	201	205	212	220	223	236	252	3 0
3 2	139	150	138	173	184	195	200	206	215	217	230	246	3 1
3 3	135	147	135	169	179	190	195	201	210	212	225	240	3 2
3 3	132	143	132	164	175	186	190	196	205	207	220	234	3 3

3	4	129	114	139	129	150	143	160	157	171	172	181	186	191	200	202	215	213	229	3	4
3	5	126	112	136	126	146	140	156	154	167	168	177	182	187	196	197	210	208	224	3	5
3	6	123	109	133	123	143	137	153	151	163	164	173	178	182	192	192	205	203	219	3	6
3	7	120	107	130	121	140	134	149	147	159	161	169	174	178	188	188	201	198	214	3	7
3	8	117	105	127	118	137	131	146	144	156	157	165	170	174	184	184	197	194	210	3	8
3	9	115	103	124	116	134	128	143	141	152	154	161	167	171	180	180	193	190	206	3	9
3	10	112	101	122	113	131	126	139	138	149	151	158	164	167	176	176	189	186	201	3	10
3	11	110	99	119	111	128	123	137	136	146	148	155	160	164	173	172	185	182	197	3	11
4	0	108	97	117	109	125	121	134	133	143	145	152	157	160	169	169	182	178	194	4	0
4	1	106	95	114	107	123	119	131	131	140	143	148	154	157	166	165	178	175	190	4	1
4	2	103	93	112	105	120	117	129	128	137	140	146	152	154	163	162	175	171	186	4	2
4	3	101	92	110	103	118	114	126	126	135	137	143	149	151	160	159	172	168	183	4	3
4	4	100	90	108	101	116	112	124	124	132	135	140	146	148	157	156	169	165	180	4	4
4	5	98	88	106	99	114	110	122	121	130	133	138	144	145	155	153	166	162	177	4	5
4	6	96	87	104	98	112	109	119	119	127	130	135	141	143	152	150	163	159	174	4	6

\* English Board of Trade Rules.

† Lloyds and Bureau Veritas Surveys.

In the above formulæ  $W.P.$  is the working pressure,  $T$  is the thickness of the plate from which the furnace is made in sixteenths of an inch for the Board of Trade,  $D$  is the greatest diameter of the flue in inches.

The Board of Trade, in the United Kingdom, has complete command over all that shall be done in the matter of steam appliances on British-owned ships, and their surveyors are constantly in evidence at seaports, to see that their rules are carried out. Lloyds and the British Corporation are insurance companies, who insure ships, and also keep their surveyors at every port to see that their requirements are carried out. The Bureau Veritas is a French company, similar to Lloyds in this country, and it keeps its surveyors in all ports. The table on pages 66 and 67 gives the working pressures of boilers to which the corrugated flues are fixed, according to the above formulæ, as allowed by the Board of Trade, and by Lloyds and the Bureau Veritas. The figures on the extreme left and the extreme right of the table, are the smallest internal diameters of the furnaces inside of the corrugations. The figures at the top of the tables,  $\frac{7}{16}$  inch,  $\frac{1}{3}\frac{5}{8}$  inch, and so on, are the thickness of the plates from which the furnaces are made, and the figures below each plate thickness are the pressures allowed respectively by the Board of Trade and Lloyds and Bureau Veritas, with the given thickness of plate, and the given size of furnace. It will be noticed, in glancing down the table, that the pressure allowed, though it varies between the Board of Trade and the insurance companies, follows in both cases two simple laws. The pressure that may be allowed increases with the thickness of the plate of which the furnace is composed, and nearly in proportion to that thickness, as expressed by the formulæ, where  $T - 2$  is one of the factors. The pressure that is allowed also decreases with all thicknesses of plate, as the diameters of the furnaces increase.

## Setting Cornish and Lancashire Boilers

It has been mentioned above that Cornish and Lancashire boilers have brickwork flues provided for the hot gases, underneath the boiler, and at its side. This entails, as will easily be understood, the formation of the brickwork setting, with which every one who has visited a boiler-house, is familiar. Two points should be noted in connection with the boiler brickwork. The brickwork should be so arranged as to efficiently support the boiler, and to provide flues that can easily be cleaned; but the support of the boiler, and the arrangement of the flues must be such that the brickwork does not carry off heat. To meet this requirement the support of the boiler



underneath should be by blocks of sections designed to offer a good support to the boiler, while at the same time offering a high thermal resistance, by small contact with the mass of the boiler. Further, the brickwork should be so arranged as to offer the highest possible resistance to the passage of heat through it. In America a firm known as the McLeod and Henry Company make what they call a steel mixture, which is employed for the purpose, and which is stated to be stronger and more durable, and to be more refractory than ordinary firebrick, the fusing-point of the mixture being given as 4000° F.

Messrs. McLeod and Henry advise the formation of a back arch for the connection between the boiler flues and the side flues, etc.

Another important point is, the brickwork should be quite airtight. One of the causes of loss of heat in boiler services where brick flues are employed is, air filters through the joints of the brickwork, and mingles with the hot gases passing through them, lowering their temperature by the absorption of heat from the hot gases to raise the temperature of the incoming air to that of the gases themselves. Every cubic foot of air passing in, absorbs about 20 B. Th. units.

## **Firing Lancashire and Cornish Boilers from Outside**

It will be understood that one of the important features of both the Cornish and Lancashire boilers is the internal firing, the furnace being completely surrounded by the water of the boiler, the whole of the heat liberated by the combustion of the fuel being delivered within the boiler, and therefore being in the best position for efficiency. With some forms of fuel, however, it is not possible to arrange this. As explained in the first chapter, with low grade fuels, such as the refuse from sugar-canes, cotton, saw mills, etc., which are very valuable as fuels in certain parts of the world, much larger quantities have to be consumed than is necessary with good coals, and hence a larger grate area, and a larger furnace generally must be provided, and this necessitates a furnace being placed outside of the boiler. This is the position the furnace occupied in the early days of boiler work, and it also occupies that position with several other forms of boiler. There are two methods that may be employed with external firing. The furnace may be carried underneath the bottom of the boiler, as shown in Plate 2c, the hot gases passing through a flue built for it under the boiler, returning through the flues on the inside of the boiler to the front, and thence by the side flues to the back and to the chimney. Or the furnace may be fixed

in front of the boiler, the boiler flues extending the whole length of the boiler shell, and the furnace gases passing straight into the flues from the furnace, and afterwards taking their usual course. A boiler furnace constructed on these lines, by Messrs. Galloway, is shown in Plate 2B, and a special form for cane refuse, etc., in Plate 3A. Messrs. Meldrum have also adopted this plan in the furnace they have arranged for burning colliery and other refuse.

### The Galloway Boiler

As already mentioned, the Galloway cone tube has been very largely adopted, and is fitted to the flues of Lancashire and Cornish boilers by all makers. Messrs. Galloway themselves have evolved a boiler of their own, of the Lancashire type, which has been developed around the experiments that have been made with their cone tube, and which differs in several respects from the ordinary Lancashire boiler. The first difference is, while the two furnaces are kept separate, the two flues into which the furnaces open are made into one.

The joint flue was first developed of an elliptical section, but has since been altered to one in which the upper and lower walls of the flue are parts of concentric circles, the two arcs being set up with different radii from one centre, and the cone tubes are inclined radially towards each other. The result of this is stated to be the production of a very successful boiler, and a good circulation through the cone tubes.

In addition to the above, Messrs. Galloway form pockets in the sides of the flues, the object of this being to increase the heating surface, and to aid in strengthening the flue. These points are shown in Plates 2A and 2B.

### Multitubular Boilers

In describing the Lancashire and Cornish boilers, it was mentioned that the arrangement of the flues was designed to provide as large a heating surface as possible, that is to say, to divide up the water in the boiler as much as possible, and to bring as many parts of it as possible in contact with some hot plate having hot gases on its other side. The multitubular boiler, in its somewhat various forms, is designed to still further accomplish this, and any one of the boilers made on this pattern will furnish a given quantity of steam from a boiler of very much smaller size than either the Lancashire or Cornish, designed for the same work.

In the multitubular boiler, as its name shows, the single flue of the Cornish boiler and the two flues of the Lancashire boiler are displaced by a large number of very much smaller tubes, generally ranging from 3 to 4 inches in diameter, running usually from end to end of the boiler. The hot gases pass through these tubes, the water lying all around the tubes in the space not occupied by them.

The principal reason why multitubular boilers are not more employed than they are, seeing the greater steaming capacity for a given weight and size, is the difficulty of cleaning them. In every boiler there are two surfaces upon which deposit takes place, both of which tend to offer resistance to the passage of heat from the hot gases to the water—viz. the surface in contact with the gases, on which finely divided carbon, or soot, is apt to collect, and the surface in contact with the water, upon which the salts carried by the water are also apt to deposit. In the case of tubular boilers, it is not very difficult usually to clean the tubes, but it is exceedingly difficult to clean the water space between them, more particularly as the substances which are deposited upon the metal there are very clinging. The salts that are carried by the water are often combined with some of the oil that has been employed for lubricating the engine, and that has been carried as vapour, or in a finely divided state, into the condenser, and has found its way back from the condenser into the boiler. The substance formed by the oil and the salts is particularly tenacious, and offers a very high resistance to the passage of heat through it.

In the multitubular boiler, which is usually fired from a furnace below the bottom of the boiler, the hot gases pass from the back of the boiler through the tubes to the front, and thence by the side flues to the chimney. The gases, it will be seen, split up at the back of the boiler into small sections, each section passing through its own tube, the whole reuniting at the front and passing to the sides, as explained. The heating surface, the quantity of metal plate in the multitubular boiler, acting as a separator between the hot gases and the water, is enormously increased, and in addition, the mass of the hot gases being so divided, the gases themselves very much more readily part with their heat to the metal tubes surrounding them, because there is a smaller core of gas in each of the tubes. It will be understood that when hot gases are passing through the flues of Lancashire or Cornish boilers, the gases that are in contact with the shells of the flues are doing the most work, because the gases themselves do not conduct heat very readily, and therefore the heat from the inside mass cannot easily reach the metal plates of which the flues are composed. This is one of the reasons why the Galloway cone tube so increases the efficiency of the Lancashire and Cornish boilers, because it breaks up the hot gases, as well as providing

heating surface, and in the multitubular boiler, it will be seen, the process is carried very much further.

## Forms of Multitubular Boiler

There are several forms of multitubular boilers, known by various names, and having slightly different construction, according to the purpose for which they are employed. They are known as the Marine boiler, the Locomotive boiler, the Dry-Back boiler, and simply the Multitubular boiler. In all of them there is the nest of tubes through which the hot gases pass. In the marine boiler, the dry-back boiler, and the ordinary multitubular boiler, the hot gases pass from the back of the boiler through the tubes to the front. In the locomotive boiler they may pass from the front—that is, directly from the fire-box to the back of the boiler. In the case of the locomotive employed on railways, the fire-box is at the rear of the boiler, in the direction the train is running, and in that case it would be proper to say that the hot gases pass from the rear to the front; but they pass directly from the fire-box into the fire-tubes, without changing their direction, and thence to the smoke-box and up the chimney, while in the remaining forms of multitubular boiler, the direction of flow of the gases is reversed after leaving the fire-box or the combustion chamber beyond. Plate 3B shows a multitubular boiler made by the Atlas Co. of America.

## The Ordinary Multitubular Boiler

The ordinary multitubular boiler has been partially described above. As made by Messrs. Davey, Paxman & Co., it takes two principal forms, known as the English and American pattern. The English pattern consists of a short cylinder, with tubes occupying the lower portion, the furnace being fixed below the boiler, which is set in brickwork in the usual way, and a mud drum is fixed below the boiler, and at right angles to it, with an entrance into the back of the boiler, to receive the deposit from the water, as explained in previous sections, the boiler being set in brickwork. The course of the gases in this form is from the furnace, past the fire-brick bridge at the end of the furnace, to the combustion chamber at the back, thence through the tubes to a brick smoke-box in the front, thence through the side flues to the chimney. In the American pattern made by this firm, the chimney is at the front, where it opens from a cylindrical smoke-box, and the boiler is supported from iron girders standing upon iron columns, instead of by the brickwork, the boiler

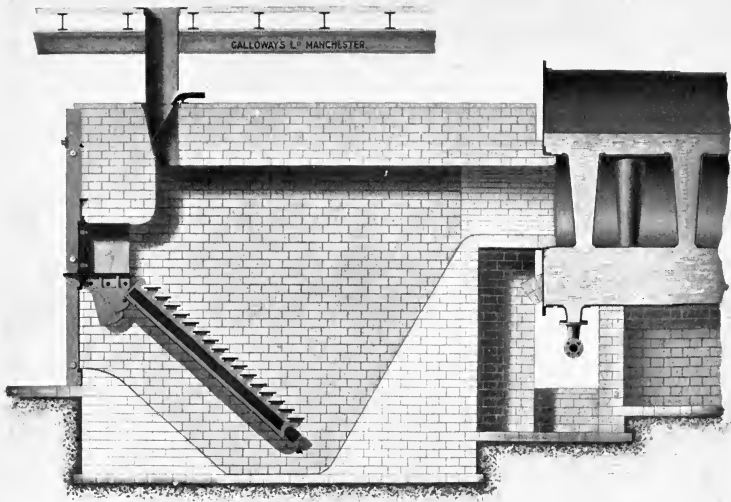

PLATE 3A.—Furnace and part of flues of Galloway boiler arranged for burning wood, gas coal, etc. The fuel falls down the steps shown, as it consumes, and the hot gases pass up into the boiler flues.



PLATE 3B.—Externally fired multitubular boiler, as made by the Atlas Co.

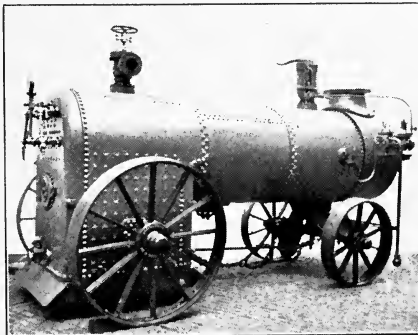

PLATE 3C.—Locomotive type of boiler, as adopted for portable engines by Messrs. Marshall. [To face p. 72.]



itself being built in by brickwork, something on the lines of the water-tube boiler, explained later, and the gases pass over the whole of the outside shell of the boiler, and through the tubes to the front. There is also a cylindrical drum fixed above the iron girders, for the reception of the steam.

## The Locomotive Type of Boiler

The locomotive type of boiler is very much employed for portable boilers, carrying engines above or below them, such as those used for traction purposes, and for agricultural purposes, driving thrashing machines, etc. It is also used largely for semi-portable boilers, for temporary work, such as contractor's work on docks, waterworks, railways, etc., the reason being that it is easily and quickly set up, and easily and quickly removed when required. In the locomotive type of boiler, only as much of the heat of the flue gases can be transmitted to the water, as will pass across from the tubes to the water surrounding them. Use cannot be made of the outer shell of the boiler, in the manner in which it is made use of in the Lancashire and Cornish boilers; and it is necessary that water shall be present on the inside of the boiler shell everywhere, except, of course, in the fire-box, and as far as possible round that also. With the multi-tubular boiler, as will be understood from what has been said before, the absence of the side and bottom flues does not make anything like as much difference to the economy of the boiler as it would in the case of the Lancashire and Cornish boilers, because the flue gases being so thoroughly divided up by the fire-tubes, the heat is very much more taken from them in passing through the tube, than through the Lancashire or Cornish flues. In the portable engines that are used for agricultural and traction work, the tubes are made very small, but they are easily cleaned, as the smoke-box into which the tubes open at the funnel end is closed by a large iron door, and when this door is open, the ends of the fire tubes are exposed and are easily reached. It is not so easy, however, to clean the spaces between the tubes in which the water lies, and in which deposit occurs, and therefore in all boilers of this kind the water should be as soft as possible. Plate 3c shows a portable boiler of this type made by Messrs. Marshall.

## The Marine Boiler

In the marine boiler quite another set of conditions has to be fulfilled. The boiler, it will be remembered, is fixed on board ship,

as near the middle of the ship as possible. It has to be practically self-contained, and all the heat that is extracted from the gases must be obtained without the aid of brick or similar flues. Further, conditions of safety for the remainder of the ship demand that there shall be a mass of water for the hot gases to impinge against as they issue from the furnace, and for that reason the marine boiler is known as the "Wet-Back" boiler. Its construction is as follows: It may be circular or rectangular in section. It carries one, two, and sometimes three furnaces at its lower part, the furnaces being fixed internally, in a similar manner to those of the Lancashire and Cornish boilers, and the space above the furnace is filled with a nest of tubes, as shown in Plate 4A. The hot gases pass from the furnace into a vertical space provided for them at the back of the boiler, thence through the fire-tubes, which are fixed horizontally, to a smoke-box in front, and thence to the funnel, this occupying, as usual, a position in the centre of the ship. At the back of the combustion chamber, into which the furnace gases pass, is the chamber containing water, which communicates with the space surrounding the fire-tubes, and also extends to the space surrounding the furnaces. Where the boiler is of the cylindrical form, it resembles a Lancashire or Cornish boiler to a certain extent, as will be seen from Plate 4A, but it is very much shorter, and the space usually occupied by the free body of water and steam is occupied by the tubes with the steam space above them. The arrangement of the furnaces of marine boilers varies somewhat, some of them being known as "dry bottom," and others "wet bottom," the difference being, with the dry bottom there is very little water below the furnaces, and in the wet bottom there is a fairly considerable quantity.

### The Dry-Back Boiler

The dry-back boiler is really a form of the ordinary multitubular boiler, or it may be considered a form of the marine boiler, from which it is distinguished by having no water space at the back of the boiler, beyond the combustion chamber into which the flue gases empty. The dry-back boiler is made by nearly all the large firms; in particular, Messrs. Davey, Paxman & Co. have made a speciality of one which they call their "Economic" boiler. In this form of boiler the furnaces are carried in the boiler, or, as it is expressed, the boiler is internally fired, just as the Lancashire and Cornish boilers are, and the hot gases pass into a combustion chamber at the back of the boiler, thence through the nest of tubes mentioned, to a smoke-box on the front, thence to side flues formed from brickwork, in a similar manner to the Lancashire and Cornish boiler, and thence to the



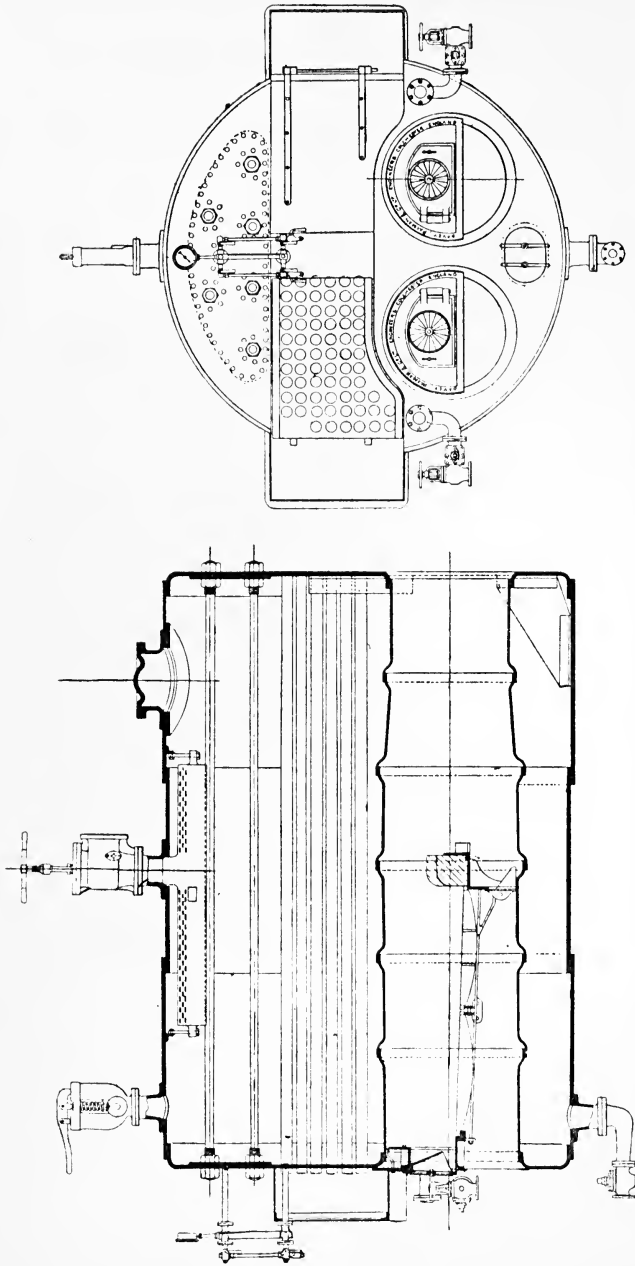

FIG. 10.—Longitudinal and Transverse Sections of Messrs. Davey & Paxman's "Economic" Boiler, in which a number of Fire-tubes are employed, on Similar Lines to the Marine Boiler.

chimney. The boiler, like all multitubular boilers, is much shorter than the Lancashire and Cornish boiler, and is of about the same diameter, for the same evaporative power, and is set in brickwork in a similar manner to the Lancashire and Cornish boilers. It is shown in Fig. 10.

### Combined Cornish and Multitubular Boilers

Another form of boiler, that is made by several firms in this country, and in America, is the Combined Cornish and Multitubular boiler. It is made in several forms according to the fancy of the makers. In one form made by Messrs. Galloway, there are two distinct boilers, or rather two distinct cylinders, standing one above the other, connected by steam pipes, both built in by brickwork. The lower cylinder is the Cornish boiler with its single flue and furnace, inside the boiler shell as before; and the upper cylinder is shorter, and forms the multitubular boiler. Above the latter again stands a smaller cylinder forming the steam drum. The hot gases pass through the internal flue of the Cornish boiler, up at the back of the boiler to the multitubular portion, through the tubes to the front, back by the side flues of the multitubular portion to the back of the boiler, then from the side flues of the multitubular to the side flues of the Cornish portion, from the back to the front end, thence into the bottom flue of the Cornish portion to the back end and to the chimney.

Messrs. Fraser & Chalmers also make what they call Compound Cornish Multitubular boilers, the ordinary Cornish single flue occupying the front portion of the fire space, the rear portion of the space usually occupied by the flue being filled with tubes. The hot gases pass from the furnace over the fire-brick bridge, to the combustion chamber at the back, thence through the tubes to the back of the boiler, and thence by the usual paths under the boiler, and by the side flues to the chimney. Messrs. Marshall make a boiler of this kind, as shown in Fig. 5.

In the American form, known as the Robb-Mumford boiler, a section of which is shown in Fig. 11, there are two cylinders, as in the Galloway pattern, connected together by steam and water pipes, but the office of the upper cylinder is merely to hold the water and for circulation. The lower cylinder is slightly inclined to the horizontal, the back end being above the furnace end. The furnace occupies a large portion of the lower cylinder, and the tubes open directly from the furnace, very much as in the case of the locomotive boiler. Both cylinders are enclosed, sometimes in brickwork, and sometimes by steel plates. The hot gases after passing through the

tubes, return to the chimney, which opens from a smoke-box in front, passing over the surfaces of both the lower and upper cylinders.

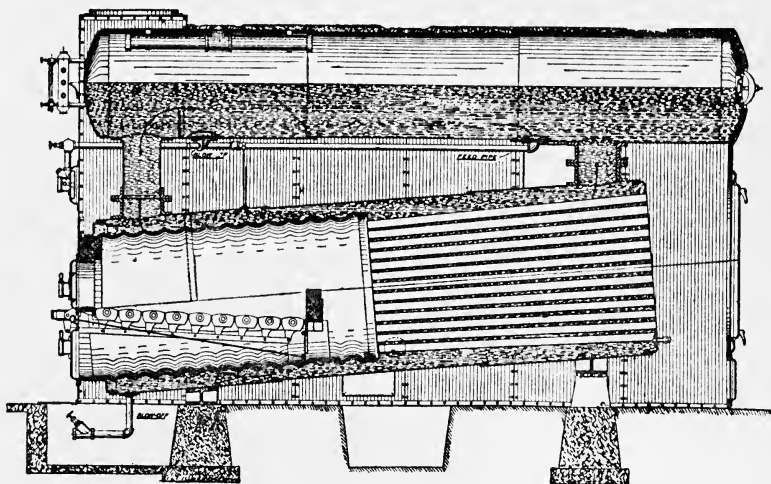

FIG. 11.—Sectional View of Robb-Mumford Standard Boiler.

## Water-tube Boilers

In water-tube boilers, as their name implies, the conditions ruling with the fire-tube boilers are reversed—the water is held in tubes connected to drums, the steam rising from the tubes and passing into the drums, where a steam space is left, and the hot gases play all round the tubes, and the under surface of the drums. The construction of water-tube boilers varies quite as much as that of fire-tube boilers, but all are on certain main lines. All of them must have, as in the case of fire-tube boilers, a space sufficient to hold a certain quantity of water, another space sufficient to hold a certain quantity of steam, an arrangement for delivering water to the water space, as a portion is converted into steam, an arrangement for carrying the steam away from the steam space when it is formed, and when it is to be used. It must also contain some arrangement for burning the fuel that is to be employed to furnish the heat, and for directing the hot gases over the tubes and the drums, in such a manner that all the heat is extracted from them that is not required to furnish draught. The fuel is burned in very much the same manner as in the fire-tube boiler, though the furnaces, as will be explained, are rather different, and there is the same problem, the hot gases passing from the surface of the burning fuel having a temperature

of approximately 2400° F. and being required to be cooled down before leaving the boiler to about 600°, or where forced draught is employed, to considerably less. The whole construction of water-tube boilers necessarily differs entirely from that of fire-tube boilers, in the majority of forms, because the arrangements are quite different. In the fire-tube boilers, it will be remembered, there is a shell holding water, and hot gases are passed through flues, tubes, etc., piercing the water, and round the sides and bottom of the shell. In the water-tube boiler the water is held very largely in tubes, with drums or cylinders or some similar arrangement above, to assist in the circulation, and to form a receptacle for the steam. It will be understood that steam, when it is formed, being so much lighter than water, rises, and if it is not condensed before it reaches the surface, comes away from the water, and enters the space provided for it. One of the advantages claimed for the arrangement of the Lancashire boiler, with the hottest portion of the gases in direct contact with a small depth of water, is the fact that the steam formed there has only a short distance to rise to the steam space. As will be seen, in the water-tube boiler the steam has frequently a very long distance to pass before entering the steam space, and it may happen, and does, that steam formed in one part of the boiler, in one part of the tubes, may become water again by passing through a body of water at a comparatively low temperature. It by no means follows that this renders the boiler inefficient, inasmuch as in order that the steam may become water again, it must give up its latent heat to the water, and in doing so, must raise the temperature of the water very considerably.

It will be remembered that in dealing with the Lancashire boiler, one of the points that was mentioned as of considerable importance was the setting of the boiler, so that it should be well supported, but without the supports carrying off much heat, the supports being in the form of fire-bricks moulded to a special form. In the majority of water-tube boilers, though brickwork enters very largely into the arrangement, it does not support any portion of the boiler. A favourite arrangement, employed by the Babcock & Wilcox, and by the Stirling Boiler Company, and others, is: A space of rectangular section is formed by iron pillars supporting iron girders, the space being afterwards closed in by fire-bricks on the inside, and glazed tiles on the outside, leaving spaces for the furnace doors, and the doors required for getting at the tubes, etc. The girders supported by the pillars themselves form the supports for the drums, tubes, etc., and the rest of the apparatus, and as girders and supporting pillars can be multiplied as much as may be desired, within certain limits, the limits being the ability of the supports to carry off heat, a very substantial structure results, that is largely independent of expansions and contractions, so far as supports are concerned. The form and

arrangement of water-tube boilers vary very considerably, as do most engineering appliances, according to the ideas of the inventors and the manufacturers who work out the inventors' ideas, but the great majority of them take the form indicated above, in which there are one or more drums occupying the upper portion of the apparatus, and resting or supported by the girders, and supported partially by the brickwork surrounding them, the space below being occupied partly by the tubes, which have various forms, and partly by the furnace. The tubes are of various forms, and various sizes, from very small in the Thornycroft and Yarrow torpedo-boat boilers, up to four inches in the Babcock and other boilers of the same type.

The arrangement for extracting the heat from the hot gases formed by the combustion of the fuel, is necessarily different from that in the Lancashire and Cornish and multitubular boilers. For practical purposes the whole of the rectangular box, that usually forms the lower portion of the boiler space, takes the place of the flues in the fire-tube boilers. Instead of the hot gases passing through the different flues in succession, or in series, as electrical engineers would express it, they to a certain extent find their own way between the surfaces of the tubes containing the water, guided usually by baffles of incombustible material, arranged to give them a circuitous path, and to ensure that every part of every tube shall be licked by the gases on their way to the chimney. In some forms of water-tube boiler, particularly in such forms as the Climax, described on p. 98, and two of the forms of Messrs. Thornycroft's boiler, the hot gases have simply to find their way between interstices left between pipes in which water is circulating, the pipes being curved in various forms.

Nearly all forms of water-tube boiler have a mud drum placed at the bottom of the rectangular space mentioned, where the boiler is of the rectangular form, the mud drum having the same office as the mud hole in Lancashire boilers, and the mud drum described in connection with some forms of multitubular boilers.

### **An Advantage Claimed for Water-tube Boilers with High Pressures**

One reason for the increase in the use of water-tube boilers during recent years is the increase of the steam pressures that has been referred to in the first chapter. In the formulæ given for the working pressure of boilers with different patterns of furnaces on p. 65 it will be remembered that the diameter of the furnace formed the denominator of the fractions comprising the formulæ. A similar

formula is employed for the working pressure allowable with Cornish or Lancashire boilers, for the boilers themselves.

In both formulæ the working pressure allowable with any given thickness of boiler plate and other construction depends inversely upon the diameter of the boiler. The larger the diameter of the boiler, the thicker must be the steel plate of which the boiler is composed for a given pressure, and it will easily be understood that as boiler pressures increase, the sizes of the boilers must either be limited or the thickness of the boiler plate must be increased considerably, and with it the cost of working, the cost of the material itself, and the efficiency of the boiler will be reduced, from the fact that the increased thickness of the plate will allow only a smaller quantity of heat to pass from the hot gases through the boiler shell to the water at the sides and bottom. So far, makers of Lancashire boilers have had no difficulty in constructing boilers for pressures of 200 lbs., which is rather higher than most steam users care to go at the present time, except for steamships and special cases. There is also no difficulty whatever in arranging batteries of boilers, and this is merely a continuation of the plan that was necessarily adopted in low-pressure days, because, as already explained, much more steam was required with low pressures than with high. On the other hand, there can be no doubt that the increase of steam pressures has increased the strain upon the boiler shells in the case of the Lancashire and Cornish boilers. It will be remembered that with all fluids, liquids, and gases the pressure communicated to any part of a body of fluid is transmitted through the fluid equally in all directions, and this applies to the case of the mixed fluids, the water and steam in Lancashire and Cornish boilers. When water only is in the boiler, as when it is first filled up for steam raising, the only pressure upon any part is that due to the weight of the water. When steam is formed, however, the pressure acquired by the steam is transmitted through the body of the steam in the steam space and through the body of the water in the water space to every part of the boiler, and particularly to the boiler shell, the pressure so transmitted acting radially upon the rings of which the boiler is built up, and tending to force the seams open, or to burst a plate if there is any flaw in it. The pressure in pounds exerted upon any ring of the boiler is found by multiplying the total surface of the ring in inches by the pressure of the steam in pounds. Thus, taking a ring 6 feet in length and a boiler of 8 feet in diameter and a steam pressure of 200 lbs., the total force exerted by the steam tending to open the joint of the ring, or to rupture the plate of which the ring is formed, is found by the formula—

$$F = P \times D \times L \times \pi$$

where P is the steam pressure in pounds, D is the diameter of the

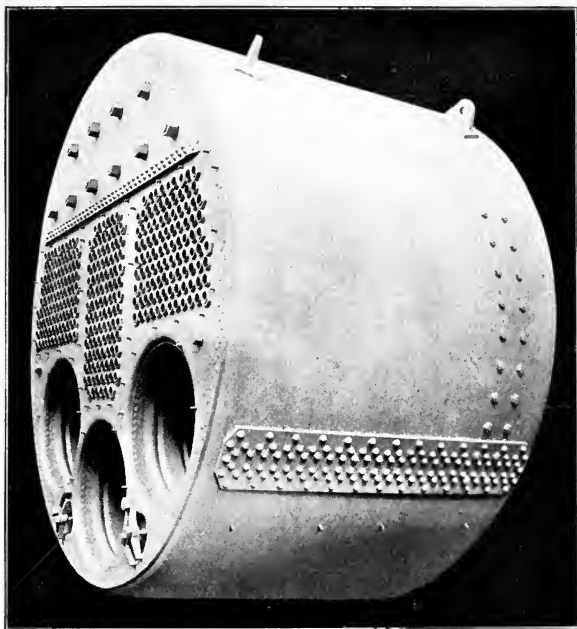

PLATE 4A.—Three-furnace marine boiler, made by the Central Engineering Works, Hartlepool.

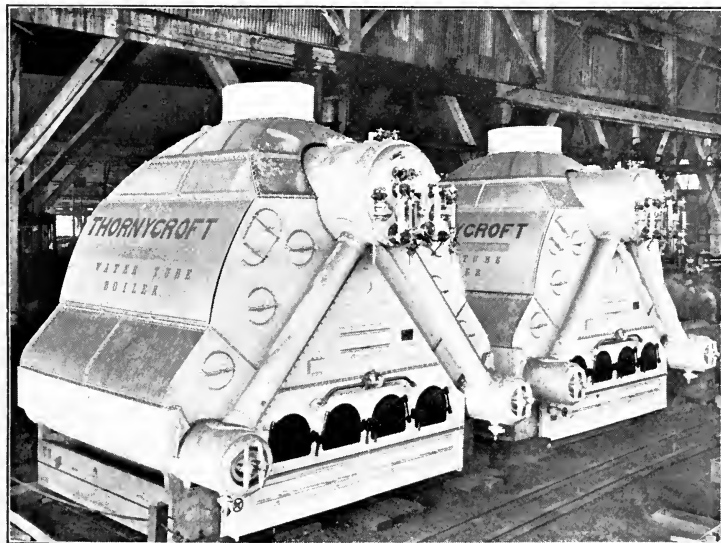

PLATE 4B.—Thornycroft water-tube boilers, arranged for ship work. The steam drums are seen at the top, the furnaces below, the tubes being inside the casing.  
[To face p. 86.]





boiler in inches,  $L$  is the length of the ring in inches. For the case mentioned,  $P$  is 200,  $D$  is 96,  $L$  is 72, and  $F$  will therefore = about 188 tons.

Though there is no difficulty whatever in providing material to resist this strain, nor to make joints in the material of which the boiler is composed also to resist the strain, it will be seen at once that if, as in the case of all water-tube boilers, the largest diameter of any vessel exposed to steam pressures is reduced to, say, 3 feet the chance of rupture of the shells of which the vessels are composed is enormously reduced, and hence higher pressures can be employed with greater confidence where boilers are in the hands of men who are not always as careful as they might be; and, again, it is possible to economise in the material of which the boilers are constructed.

It will be noted also that in the water-tube boiler, the major portion of the apparatus is exposed to very much smaller strains than those to which the larger portion of Cornish and Lancashire and multitubular boilers are exposed.

### **Convenience of Transport of Water-tube Boilers**

Another undoubted advantage that is claimed for water-tube boilers is their great convenience for transport and for fitting-up. For transporting machinery to the Colonies or to foreign countries, it is a great convenience to be able to take machines apart into portions that are handled and packed easily, and the packages of which can be handled by the cranes, etc., on dock sides. It will be seen from the descriptions which follow, that water-tube boilers render themselves very conveniently to this: the headers, the tubes, the drums, the furnace, the uprights, the girders all being able to be taken apart and remounted with the aid of a proper plan, where they are to be used.

And there are other cases even in this country where this convenience is of great service. In London and many of our large towns, factories and establishments, such as hospitals, hotels, etc., have grown up in the middle of populous districts, and have been gradually built in, with the result that, if it has been necessary either to fix boilers or change them for larger ones, it has been absolutely impossible to get in a Lancashire or Cornish boiler without pulling down a portion of the wall of the building. With the water-tube boiler the difficulty is very much reduced.

### **The Water Circulation in Water-tube Boilers**

The question of the circulation of water in a boiler has been dealt with generally in the first chapter, and in connection with

Cornish and Lancashire boilers on p. 54. It is claimed for water-tube boilers that their construction renders water circulation very much more easily accomplished, and very much more efficient. In all forms of water-tube boiler, as will be seen from the descriptions which follow, a certain portion of the tubes in which the water lies is exposed to the hottest portion of the hot gases, other portions of the tubes being exposed to cooler parts of the gases, and still other parts to still colder portions; the result being that there is a considerable difference in the quantity of heat transmitted through the tubes to the water lying in them in one part of the bank of tubes than in the others, this leading to the greater expansion of the water in that portion of the tubes, and therefore to the rise of the water exposed to the greater heat, its place being taken by water from the part exposed to a cooler portion of the gases, which in its turn has been forced away by heat from its own place, and so on, the result being a continuous motion of the water through the tubes and through the drums on the top provided for it.

## The Furnace of Water-tube Boilers

Practically the whole of the space under the lowest bank of tubes in the front portion of the rectangular space enclosed by the brick walls described forms the furnace, the whole width being filled with fire-bars extending from front to back for the usual distance (about 6 feet), the bars being supported in the centre of their length in the usual way. The fire-bars form a platform for the fuel, extending the whole width of the boiler. There must be one or two furnace doors and one or two ash-pit doors, as shown in the various drawings.

## Forms of Water-tube Boilers

**The Babcock.**—As mentioned above, the forms of water-tube boilers are very numerous. The Babcock and Wilcox boiler is one of those best known in this country and in America. It is shown in section in Plate 5A, and, as will be seen, it comprises a number of tubes, usually of about 4 inches in diameter, arranged at an angle of  $30^\circ$  with the horizontal, the tubes sloping downwards from the front towards the back of the boiler. The tubes are arranged in vertical banks, each of a certain number, eight being a favourite, and a certain number of vertical rows are arranged side by side, according to the work the boiler is to perform. At the front and back of the boiler the tubes are expanded into what are termed headers, which are practically boxes arranged to enable the tubes to be reached for

cleaning, and which also receive the steam from the tubes, and the water from the drum above, conveying the steam to the drum, and the water back to the tubes. The headers are fixed at right angles to the tubes, the front headers being connected by short tubes with the under side of the steam drum, the back headers being also connected with the rear part of the steam drum by long tubes, as shown. The steam drum or drums (there are more than one for large sizes of boilers) are placed longitudinally over the tubes, and the circulation of the water and steam is, from the front end of the tubes through the front headers to the steam drum, through the water in the steam drum to the tubes leading to the back headers, and thence to the back headers and the tubes again.

The rectangular space forming the furnace and combustion chamber is divided by a fire bridge of fire-brick at the back of the furnace, somewhat similar to the usual bridge at the back of the furnace of Lancashire and Cornish boilers, but the bridge is extended upwards to a rather greater height than is usual in Lancashire and Cornish boilers, and from its top a fire-brick baffle extends through the nest of tubes, being fixed at right angles to them, to the under side of the steam drum, or, where one is used, to the under side of the superheater, as will be explained later. At the back of the rectangular space, as will be seen from Plate 5A, the bottom header is met by a fire-brick bridge and baffle, and there is a third fire-brick baffle about halfway between that, connected to the furnace bridge and the back headers. From the illustration it will be seen that the front portion of the tubes, comprising half their length, is exposed to the radiation from the glowing fuel on the grate-bars, and to the hot gases at their highest temperature. It will be understood that the hot gases thread themselves between the tubes, licking round the tubes as flames do, then passing upwards to the lower part of the steam drum, down over the portion of the tubes between the two middle baffles, up through the rear portion of the tubes, across the back headers, and the tubes connecting them to the boilers, and thence down to the flue leading to the chimney.

When a superheater is employed of the Babcock and Wilcox type, as seen in Plate 5A, it is fixed in the upper portion of the rectangular space forming the heating chamber, and receives the hot gases as they pass. The Babcock and Wilcox Company also manufacture a special form of their water-tube boiler for use on board ship. The principal difference between the marine type of Babcock boiler and the land type is really the form and arrangement of the tubes. They are arranged as in the other boiler, at a slight inclination with the vertical, but there are a very much larger number of them; they are smaller, and fixed very much more closely together.

In fact, the arrangement reproduces the multitubular marine type boiler described on p. 70, but with the tubes arranged to hold the water, and with the hot gases playing around them, in place of as in the fire-tube boiler, the gases passing through the tubes, and the water being round them. The steam drum is fixed directly above the tubes, connected to the front headers by very short tubes, and to the back headers by longer ones, the drum itself being fixed at right angles to the line of the tubes, instead of parallel with them. As on board ship, it is not convenient to have brickwork in the same manner as on shore; the sides of the furnace only are lined with fire brick, and the whole structure is surrounded by a removable wrought-iron casing.

### The Stirling Water-tube Boiler

In the Stirling water-tube boiler the tubes are arranged very differently from the Babcock. Longitudinal and transverse sections of the boiler are shown in Fig. 12. There is the same arrangement for supporting the drums and tubes, and the same rectangular heating chamber; but the tubes, which are in three separate banks, are fixed at a very different angle to those in the Babcock boiler. There is one drum, the mud drum referred to above, fixed at the back of the boiler, and the three banks of tubes are fixed between the three drums above, and the mud drum below. This necessarily leads to the inclination of the different banks of tubes with the vertical, being different. As will be noticed from the drawing, the rear bank is very nearly vertical, and its tubes are curved round slightly towards the bottom, to enable them to enter the mud drum in a convenient manner. This bank of tubes is fixed between the rear drum above and the mud drum. The next bank of tubes is fixed between the middle drum above and the mud drum, and is slightly more inclined with the vertical, its lower ends also being slightly curved, where they enter the mud drum. The front bank of tubes is still more inclined to the vertical, and connects the front upper drum with the mud drum. The furnace is fixed in the front, in a similar position to that in the Babcock boiler. There is only a small bridge at the back of the furnace, but there is a roof of fire-brick over the front of the furnace, and extending for three-quarters of the length of the furnace bars, this roof tending to form a combustion chamber. As in the Babcock and other water-tube boilers, there are fire-brick baffles fixed in the Stirling boiler, arranged to direct the course of the hot gases over the whole length of the tubes before passing to the chimney. There is a baffle behind the front bank of tubes, extending for three-quarters of their length from the mud drum upwards, so that the hot gases are obliged

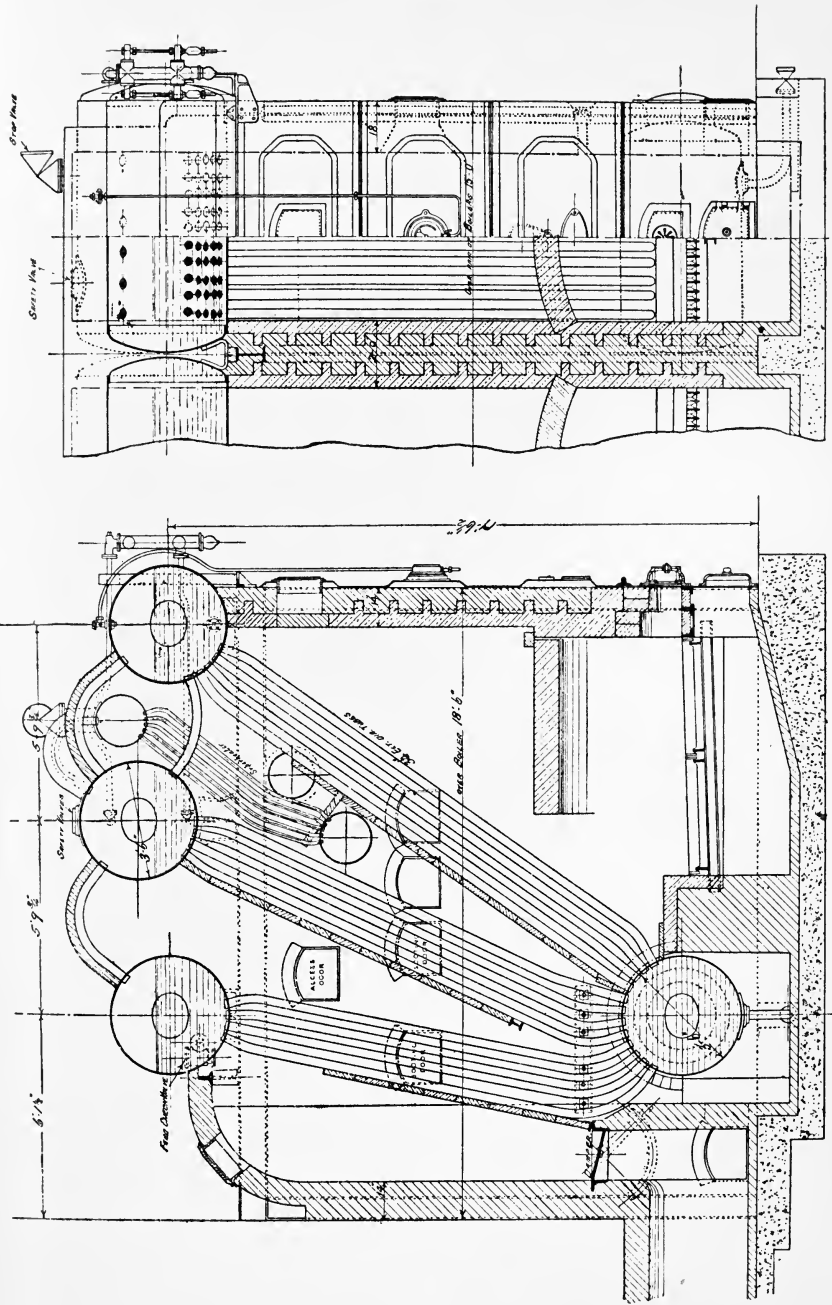

FIG. 12.—Longitudinal and Transverse Section of the "Stirling" Boiler, with Superheater.

to pass longitudinally along the tubes until they reach nearly to the front steam drum.

The second bank of tubes have a baffle fixed behind them, extending from the middle steam drum downwards for three parts of their length, so that the hot gases, after passing through the length of the front bank, pass across to the top of the second bank, longitudinally down their full length, and thence across to the rear bank. The rear bank is protected partly by a fire-brick wall, forming part of the flue leading to the chimney, and partly by a baffle fixed behind them, extending upwards for about three parts of their length, the hot gases therefore being obliged to pass along the rear bank longitudinally, and thence passing into the space that will be seen behind them, and downwards to the chimney flue. There is the same arrangement in the Stirling boiler for making the boiler of any capacity up to a certain size. The tubes are arranged in rows or stacks, of a certain number, six or eight, reckoning from front to back, and as many vertical rows are fixed side by side as may be required for the evaporation the boiler is to furnish. The Stirling Boiler Company also provide a superheater, which is fixed, as will be seen in the drawing, between the two front banks of tubes, a baffle below the lower end of the superheater ensuring that the hot gases pass over the superheater tubes.

The drums of the Stirling boiler are all fixed at right angles to the front of the boiler, as shown in Fig. 12. The three upper drums have their steam spaces connected by pipes, as shown, and the two foremost drums have their water spaces connected by tubes.

The feed water is supplied to the rear drum, and it is claimed by the Stirling Company that the vertical arrangement of the rear tubes, and the fact that they are subject to the gases at comparatively low temperature, heats the water sufficiently to allow it to deposit any foreign substances in the mud drum at the bottom, from which it can be removed by the pipe shown in the drawing. The circulation of the water then is from the rear steam drum, downwards to the mud drum, upwards through the two banks of tubes to the two upper drums. It will be noticed that the rear drum and the front drum are shown as having a greater depth of water than the middle drum. It is from the middle drum that the steam is taken. On the other hand, the front bank of tubes receive the greatest amount of heat, and it may be supposed that the largest portion of the steam is produced in them, the steam bubbles rising through the water in the tubes, into the water in the front drum, thence passing into the steam space in the front drum, and thence by the connecting pipe to the steam space of the middle drum. Steam is also produced in the middle bank of tubes, and takes its course through the length of the tubes and the water in the bottom of the middle drum to its steam space.

## The Nesdrum Water-tube Boiler

This boiler, made by Messrs. Richardson, Westgarth & Co., presents several novel features, but the main principles of its construction are the same as those of the boilers already described. There is the same rectangular space enclosed by fire-brick and glazed bricks, built in round the boiler tubes and drums, the steam drum and the banks of tubes to be described being supported by a girder, fixed on iron pillars, as in the other forms of boiler. There is only one steam drum, and there are three or four banks of tubes, according to the size of the boiler. But the banks or nests of tubes are arranged in a peculiar manner: several tubes of a given diameter are expanded into cylindrical headers, which are really small drums. There is one nest of tubes standing vertically at the back of the boiler, with a comparatively large cylinder at its top and bottom. Near the front of the boiler are two or three nests of tubes, according to the size of the boiler, each having a large header cylinder at the top, and a small one at the bottom. These two or three nests are arranged parallel with each other, and slightly inclined to the vertical. The steam drum proper is fixed between the upper header of the rear bank of tubes, and that of the rear of the three front banks. The steam drum itself and the upper cylinders of the banks of tubes, all act as steam drums. They are all usually filled partly with water and partly with steam. They all have their steam and water spaces connected together by pipes. The banks of tubes are protected by fire-brick baffles, in a similar manner to those of the Stirling boiler, the front bank having a baffle behind the tubes, extending from the rear header about two-thirds of the length of the tubes. The next bank has a baffle behind its tubes, extending from the upper header about halfway down the length of the tubes; the third bank, where there is one, has a baffle behind its tubes, extending from the lower header about two-thirds of its length. There is a horizontal baffle between the top of the baffle on the third bank, meeting the rear vertical bank about one-third of the way down. Where there are only two front banks of tubes, a baffle is carried from between the bottom headers of the rear vertical bank, and the second inclined bank upwards, and then horizontally to meet the vertical bank, at about one-third of its length from the top. There is another baffle fixed horizontally behind the rear vertical bank of tubes, and there is yet another baffle in front of the lower part of the rear bank of tubes.

The furnace is fixed in the front of the boiler, as in the other cases. There is a low fire-brick bridge at the back of the furnace bars, and the hot gases pass up the front of the front bank of tubes, curl over the upper portion of the front bank, down between the

two front banks, across the body of the second bank, up between the second and third banks, where there is a third bank, across the body of the top of the third bank, across the body of the top of the rear bank, back into the body of the rear bank, and vertically downwards along the rear bank to the flues.

A superheater is fixed in the heating chamber, between the rear bank of tubes and the last of the inclined banks. The boiler is also arranged on the same lines as the Babcock, Stirling, and others, to be built up to any size within certain limits, by fixing two or more nests in each row, side by side.

The bottom header of the rear bank acts as the mud drum for the boiler, the feed water being supplied to the upper header of the same bank, and the circulation being very much as in the Stirling. The water passes first down the rear bank of tubes, then from the rear header to the other lower headers, and from them up the inclined banks to their headers, as it is formed, passing up through the water into the steam spaces in each header, and thence to the steam space in the steam drum. Circulation of the water in all of these forms of boiler is from the water in the steam drum, and through the tubes as explained, round and round. The steam drum in the Nesdrum boiler is fixed at right angles to the line of the front of the boiler.

## The Woodeson Water-tube Boiler

This boiler, which is made by Messrs. Clarke, Chapman & Co., of Gateshead, is somewhat similar to the Nesdrum. There are three drums above, and three below, the upper drums being the steam drums, and the lower water drums, and the three pairs of drums are connected, as shown, by banks of tubes, the tubes connecting the rear drums being vertical, those connecting the middle drums a little inclined to the vertical, and those connecting the front drums still more inclined. The three upper drums are connected by cross tubes as shown, in the steam and water spaces, and the three lower drums are also connected by cross tubes. The drums are all fixed at right angles to the line of the boiler front. There is a steam dome or receiver fixed above the upper drums, and it is from this that the steam is taken. The arrangement of the masonry, etc., is very similar to that of the boilers that have been described, iron girders standing upon iron uprights supporting the upper drums, upon which they rest, and the lower drums being supported by the tubes to which they are connected, the rectangular space formed by the uprights and girders being built in with fire-brick in the usual way, the steam drums standing above. The furnace occupies its usual position in front, and there are baffles behind the tubes,



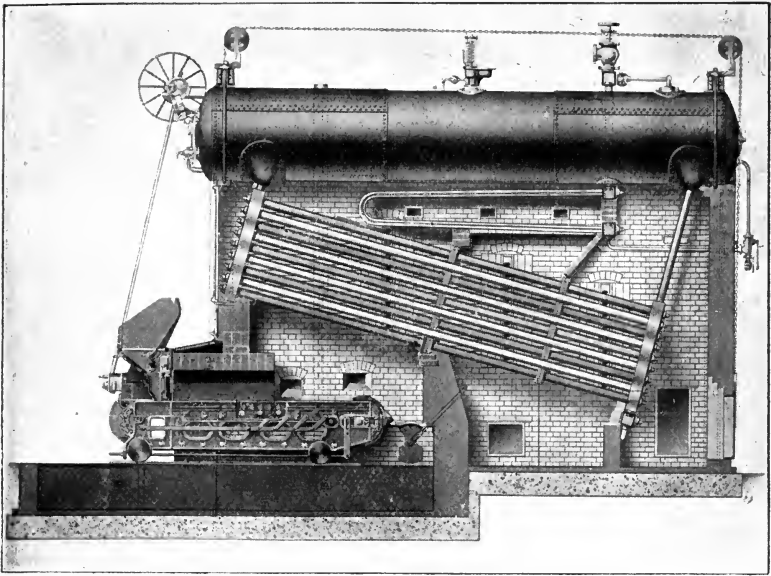

PLATE 5A.—Babcock and Wilcox Boiler, with Chain Grate, Stoker and Superheater, with brickwork removed to show the Tubes, Furnace, etc.

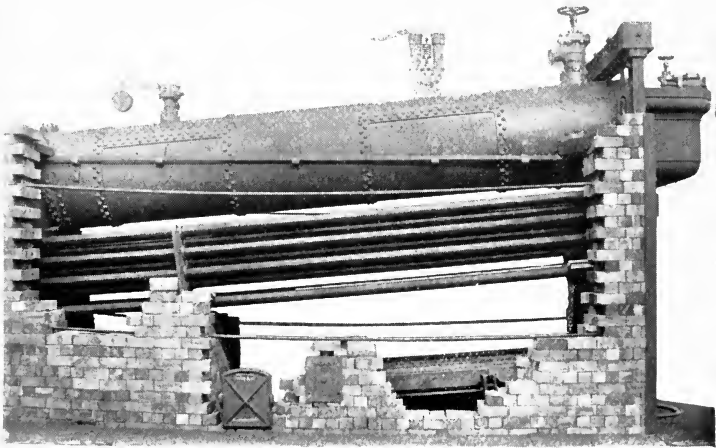

PLATE 5B.—Water-tube Boiler made by Messrs. Marshall, with a portion of the enclosing brickwork removed to show the Tubes.

[To face p. 88.]



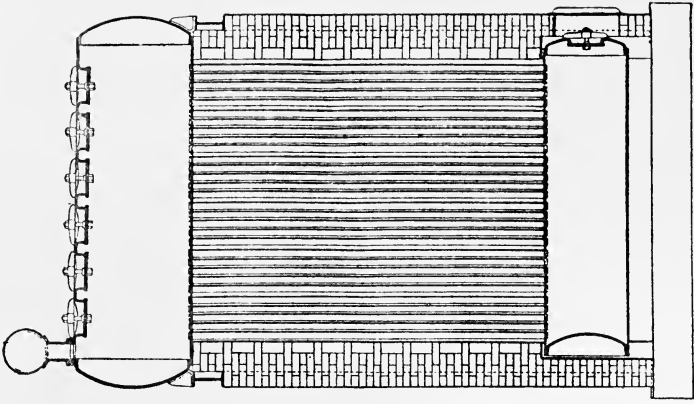

Fig. 2.

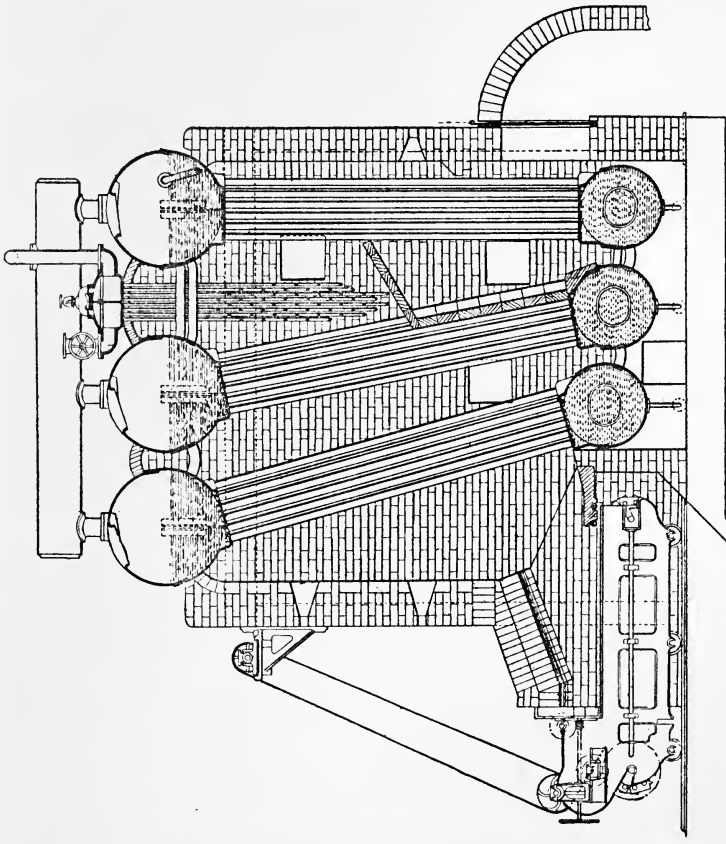

Fig. 1.

FIG. 13.—Longitudinal and Transverse Sectional Drawings of the "Woodeson" Water-tube Boiler, made by Messrs. Clarke, Chapman & Co. The Superheater is shown between the two rear banks of Tubes.

arranged to direct the course of the hot gases over the tubes and the under side of the drums in succession. The boiler is shown in section in Fig. 13. The superheater, when employed, is fixed between the rear banks of tubes, and is of the form shown.

The groups of tubes are expanded into flat discs, which form part of the upper side of the mud drums, and the lower side of the steam drums, and above the steam drums are arranged hand holes, by which any of the tubes may be reached. The feed water is carried into the rear steam drum, and passes down the bank of tubes to the rear mud drum.

It is claimed that the large area of the mud drums ensure the complete removal of foreign matter from the water in the boiler.

It will be noticed also that in this form of boiler, provision is made for expansion and contraction, by the fact that the lower drums are free to move in any direction.

## Water-tube Boilers with Horizontal, or Nearly Horizontal Tubes

There are a number of forms of water-tube boilers on the market, in which the tubes are horizontal, or nearly so. The general construction of all of them is very much on the lines of that of the Babcock-Wilcox, but each one of them has some special feature of its own, for which special advantages are claimed. There are two portions of the apparatus in which the different forms of this type of boiler differ from each other, and from the Babcock, viz. in the form and arrangement of the headers, and in the course of the hot gases over the tubes. In all forms of this type of boiler, and practically in all forms of water-tube boiler, the tubes are staggered, that is to say, alternate tubes of the same vertical row are slightly displaced to the right or left, so that the gases have an easy passage between them, and between the successive horizontal rows. This arrangement, it will be seen, necessitates a special method of connecting the tubes at the headers. In the Babcock-Wilcox, the headers of each vertical row of tubes is separated from the remainder, the header itself being curved to meet this requirement. In several of the other forms of this type of boiler, the headers, both back and front, are formed into one water leg, as it is termed. Practically the headers in these cases are formed of boxes and tanks, closed at the bottom, and opening at the top into the steam drum, the tubes being expanded into one side of them. It should be mentioned, *en passant*, that in all these forms of boiler, arrangements are made for getting at each individual tube easily, for cleaning, or for plugging up in case of the tube being damaged. For this purpose the outside covers and

the headings, the covers away from the tubes, are all pierced with holes opposite to each tube, the holes being closed by means of various forms of covers, plugs, etc., that are easily removed, when the tube is to be got at.

In the Babcock header hand holes are made in each header, as shown, and in the other forms, where there is a water leg, they are made in the side of the tank forming the water leg.

### Marshall's Water-tube Boiler

Messrs. Marshall & Sons of Gainsborough make a water-tube boiler, shown in Plate 5B, in which it will be seen the steam drum is fixed parallel with the tubes, both being slightly inclined to the horizontal. There are water legs at each end, into which the tubes are expanded, as explained on p. 90, riveted at the top end to the steam drums, openings being cut in the drum to provide for the connection, the joint being strengthened with plates on either side, on the lines of the butt joint described in connection with the Lancashire boiler. The front and back plates of each of the water legs are tied together by hollow steel screwed stays, the tubes formed by these stays being employed when the boiler is fixed in its place, for inserting a steam jet pipe to clean off the soot from the outside of the tubes. The furnace of the boiler is arranged for burning practically any kind of fuel. The tubes are of solid drawn steel. The course of the hot gases is as follows. There is a fire-brick arch under the lower bank of tubes, over the furnace, the arch extending to a little beyond the fire bridge. There are baffles also above the upper row of tubes, extending from the back header, three-quarters of the way to the front header. The hot gases pass from the furnace over the fire bridge, up over the rear end of the tubes, along the tubes longitudinally from back to front, over the front end of the upper tubes, along the under side of the steam drum, and from the rear of the steam drum by a down-take flue to the chimney.

### Davey, Paxman's Water-tube Boiler

Messrs. Davey, Paxman & Co.'s water-tube boiler has two sets of tubes, the under set inclined slightly to the horizontal, and dipping away from the front end, the upper set inclined also slightly, but rising from the front end. The headers are in the form of water legs, the back header being longer in a vertical than the front header, and both are connected directly to the steam drum, very much in the same way as Marshall's. There is also a mud drum at the rear

of the boiler, to which a circulating tube is carried from the steam drum. The tubes are solid welded, and there are the usual hand holes in the headers opposite each tube, the covers of the hand holes being made with Messrs. Davey, Paxman's metallic joint.

### The Wood Water-tube Boiler

This boiler is made by Messrs. Allis, Chalmers & Company in America, and Messrs. Fraser & Chalmers in this country. The

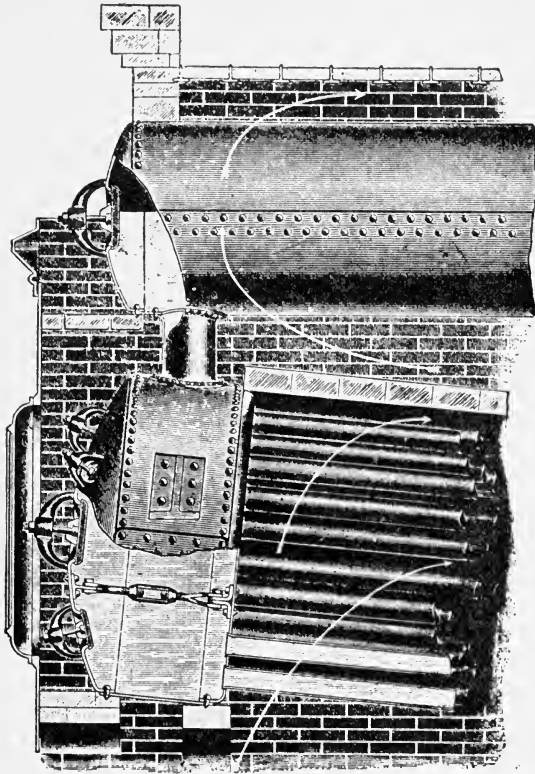

FIG. 14.—Showing a portion of the "Wood" Water-tube Boiler, made by Messrs. Fraser and Chalmers, with part of the Brickwork and of the Header cut away.

steam drum is fixed parallel with the axis of the tubes. The arrangement of the tubes and headers present some special features. They are shown in Fig. 14. The arrangement of the tubes and headers is somewhat similar to those of the Nesdrum and Woodeson boilers, but there are a very much larger number of tubes in a nest, and the tubes and their headers are arranged slightly out of the horizontal, instead of slightly out of the vertical, as in the Nesdrum. The headers in the Wood boiler are in the form of short cylinders with dished outer ends, the tubes being expanded into the inner ends, as in other forms, the front header having hand holes in the dished surface. There

is also a manhole in the centre of the front header,  $11\frac{1}{2}$  inches by 15 inches. The hand holes are arranged, not one for each tube, but so that several tubes can

be reached from each hole. The holes are elliptical in shape. The tubes with their headers forming a complete vessel, are inclined a little out of the horizontal, dipping away from the front, and connection is made with the steam drum by large pipes at the back and front. The course of the hot gases in this boiler is a little out of the usual. The tubes are surmounted by a brick arch, and the bridge at the back of the furnace extends close up to the bottom row of tubes, and the front of the bridge is slightly inclined. The hot gases pass from the furnace up over the front portion of the tubes, which are immediately above the back of the furnace, then longitudinally along the tubes, then they pass around the under side of the back header, the baffle preventing the gases from escaping at that point, thence they pass up round the back of the back header, along the under side of the steam drum, through a flue at the front end of the steam drum, along the flue shown above the drum, and thence to the chimney.

### **The Galloway Water-tube Boiler**

Messrs. Galloways make a water-tube boiler in which the steam drum runs parallel from front to back, and the tubes are slightly inclined to the horizontal. The headers at front and back are divided into sections, each section taking two sets of tubes, each of the sections of the headers being connected with the steam drum by two sets of tubes. Special cross boxes are provided for the headers.

### **American Boilers with Straight, or Nearly Straight, Horizontal Tubes**

There are several forms of boiler made in America, in which the tubes are nearly horizontal, and each of which has some special features of its own.

### **The Atlas Water-tube Boiler**

In the Atlas boiler, which is shown in Plate 6A, the tubes dip slightly from the front to the rear of the boiler, and the headers are the water legs, or tanks, that have been described on p. 90. The special feature of the boiler is the three drums shown in the figure. The drum at the rear of the boiler receives the feed water, and, it is claimed, purifies it, as explained below, extracting all foreign matter,

and thereby rendering the mud drum provided in other boilers, unnecessary. The front drum corresponds to the steam drum usually carried by water-tube boilers, but there is a third drum, shown between the other two, and which is slightly smaller, and which is the steam drum proper. In addition, as will be seen from the illustration, there are another set of tubes connecting the front and rear drums, and there is a third set of tubes connecting the front drum and the middle drum, and a fourth set, short tubes, connecting the middle drum with the rear drum. The lower tubes, which are expanded into the inner plates of the water legs in the usual way, are the steam generators proper, and the hot gases are directed over successive sections of them by vertical baffles, very much as in the Babcock, the front ends of the tubes receiving the first lot of hot gases which pass over and down over a middle section, and then upwards again, and over a rear section. In addition to this, however, the hot gases pass upwards to the upper set of tubes, on the upper side of which are fire-brick baffles, enclosed by masonry. The tubes connecting the front and rear drums are merely for circulating the water. The water in the front portion of the lower tubes being heated, expands, some of it forming steam, the steam and water passing into the front header, and thence into the front drum, where the steam is separated, rising into the steam space, which should occupy about half the area of the drum. The water passes on through the horizontal tubes to the rear drum, where it meets the feed water, and passes down through the rear header, entering the back of the generating tubes, and from thence commencing its passage again. A phenomenon is worth noting here, that is common to all of the water-tube boilers, with tubes arranged in this manner, and with the hot gases passing over the tubes in sections, viz. :— that the water entering the tubes meets first the colder gases, and has its temperature raised to a certain degree, then passing on to the next section, its temperature is still further raised, and then passing on to the front section it receives the full force of the hottest gases. This is in accordance with the latest modern practice, wherever heat is to be transferred from water to gas, from gas to air, from water to water, etc., either in raising steam, in condensing, in heating air, in cooling air, or in any other change. The hottest portion of the substance receiving heat, or from which heat is being extracted, is always nearest the hottest portion of the substance from which it is to receive heat, or to which it is to deliver heat.

The steam separated from the water in the front drum, passes along the upper range of tubes to the steam drum proper, and it is claimed that in this bank of tubes the steam is subject to superheating and drying, and that the boiler thence supplies perfectly dry steam. The amount of superheat is not great, from  $10^{\circ}$  to  $30^{\circ}$ , but



it is claimed that it is sufficient to dry the steam. Any water remaining in the steam, it is intended should pass by the tubes shown, from the middle drum to the rear drum.

### **The Water-Purifying Apparatus of the Atlas Boiler**

The water-purifying apparatus of this boiler is worth separate notice. As mentioned above, it is claimed that the apparatus separates foreign substances, that will afterwards deposit on the inside of the tubes, from the water before it leaves the rear drum. The purifier consists of a semi-conical vessel with closed ends, but with open top. The feed-water pipe discharges into one end of the purifier, and at the other end there is a blow-off cock, to the outside of the boiler. The purifier vessel is immersed in the water contained in the rear drum, and is supported from the upper portion of the drum by loose straps. It is claimed that the water in the purifier being subject to the heat of the water and steam in the rear drum, has its temperature raised to from 250° to 275° F., while in the purifier, and that it is gradually caused to overflow from the purifier vessel, at the end near which it entered at this temperature, it then passing down with the water already in the rear drum into the rear water leg, and thence to the tubes.

There is the usual provision of hand-holes in the water legs for cleansing the tubes, and of doors in the sides of the masonry, which encloses the whole apparatus; and it will be noticed that the drums are at right angles to the line of the tubes.

### **The Heine and the Detroit Water-tube Boilers**

These are two boilers very similar in other respects to those that have been described, but they have one feature in common, in which they differ from the arrangement of other boilers, viz. the course of the hot gases over the tubes. In the Detroit boiler there is a brick arch over the furnace, extending back under the tubes, for about three parts of their length. There is the usual fire-brick bridge at the back of the furnace, and the fire-brick arch over the furnace creates a combustion chamber for the hot gases. The hot gases pass along under the fire-brick arch, turn up over the rear end of the tubes, and along the tubes longitudinally to the front end. They are prevented from passing up through the tubes to the upper part of the boiler, at the rear end, by a tile baffle extending for about two-thirds of the length of the tubes. The hot gases pass round the end of this baffle

and over its top, under the lower part of the steam drum, which is fixed parallel with the line of the tubes, and thence to the chimney at the rear end, the steam drum being covered by brickwork.

## Water-tube Boilers with Vertical Tubes

Apart from the vertical boilers that will be described later, and that are principally of a smaller type, used for small work, there are two forms of water-tube boilers in which the tubes are arranged vertically, or nearly so, they are the Suckling boilers, made by Messrs. E. R. and F. Turner, of Ipswich, and the Sinclair boiler, made by Messrs. George Sinclair & Sons, Leith. In the Sinclair there are two drums, one below for water and the other above for steam. In the Suckling three, as shown. The upper drum corresponds to the steam drum of other water-tube boilers, and the drums in both boilers stand longitudinally from front to rear of the boiler. In the Sinclair boilers the upper and lower drums are connected by vertical tubes, but in the Suckling, as will be seen, the three drums are connected by tubes slightly curved and nearly vertical. In the Suckling boiler, which is shown in section in Fig. 15, the two lower drums are slightly inclined from the horizontal, dipping from the front end of the boiler, and are fixed above the furnace. The drums are connected by water legs, as shown, and the vertical tubes are expanded into the drums above and below them. The rear portion of the lower drum in the Suckling boiler is protected from the furnace gases by a fire-brick arch, this arch forming, with the usual fire-brick bridge, a combustion chamber, in which it is claimed complete combustion of the hydrocarbons, etc., is obtained. As will be seen from the drawing, the hot gases pass over the fire bridge, and thence vertically upwards over the surfaces of the two lower drums and connecting tubes. The feed-water pipe, as will be seen from the drawing, enters the upper drum at the rear, and passes a certain distance down the lower connecting pipe between the two drums. There is a small drum above the boiler for the steam, in addition to the other three. It stands at right angles.

In the Sinclair boiler the lower drum stands practically on the ground, the furnace being fixed in the front of it, and the vertical tubes are fixed in the upper and lower drums, in special landings provided for them. Vertical baffles are also fixed between the tubes, dividing them into five sections, and the hot gases pass from the furnace over the fire bridge, vertically upwards over the front bank of tubes, between the first baffle and the brick wall enclosing the boiler, over the upper end of the baffle, down over the next lot of tubes to the end of the next baffle, up over the next lot, and so on, passing

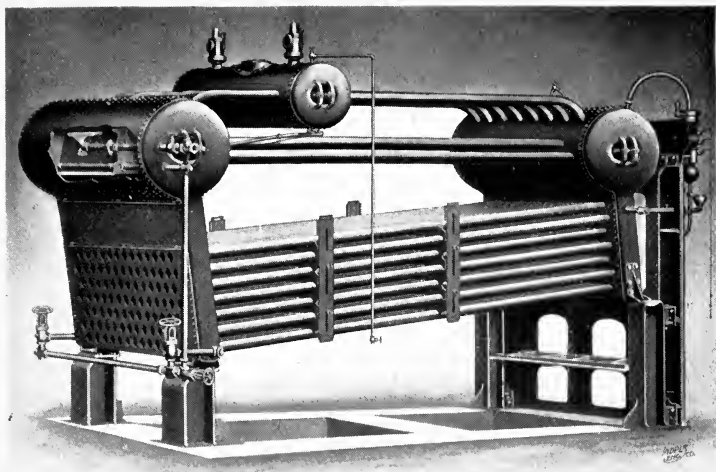

PLATE 6A.—Atlas Co.'s Water-tube Boiler, with brickwork removed.

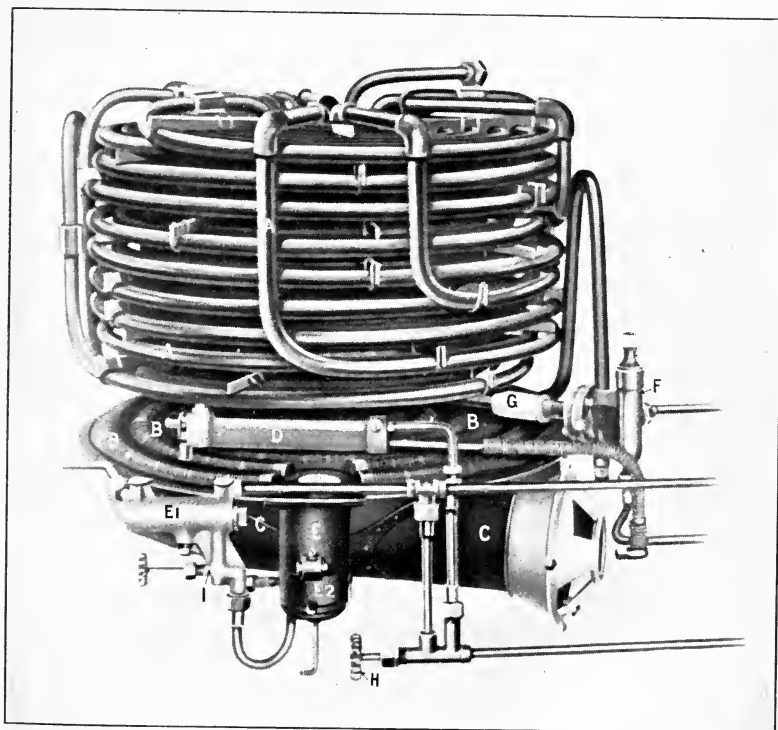

PLATE 6B.—Boiler used in the White Steam Cars. The water circulates through the Tubes, heat being supplied by the Petrol Burner shown below.

[To face p. 96.]



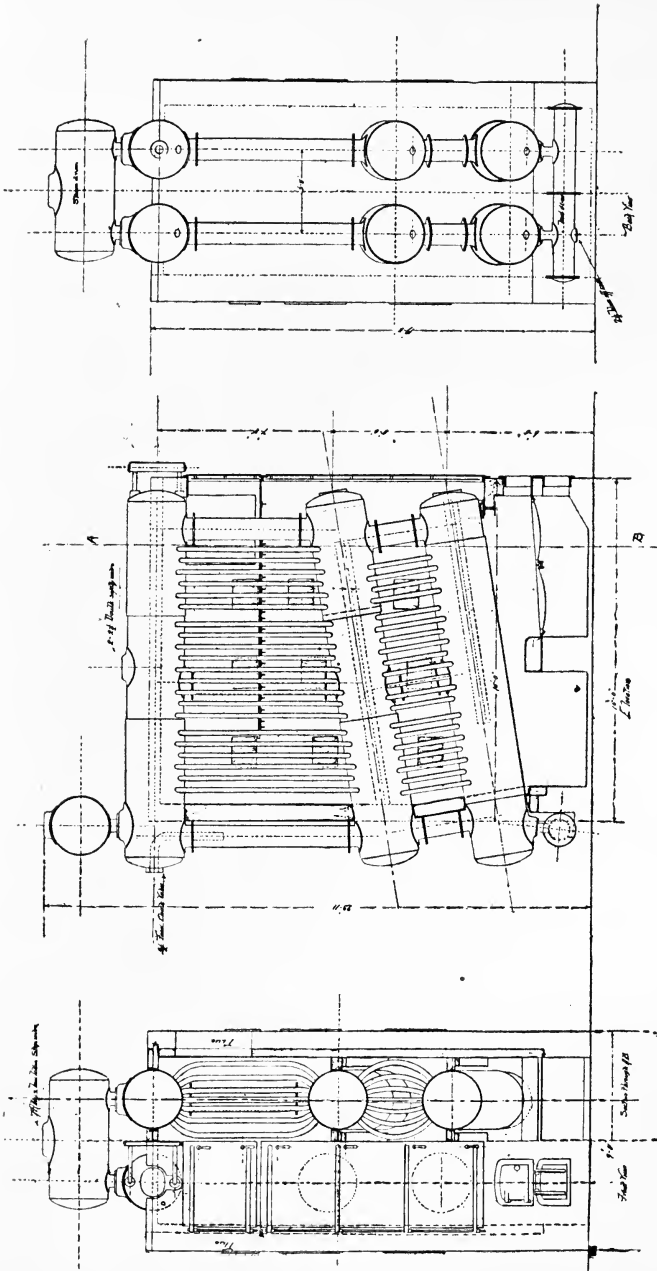

FIG. 15.—Transverse and Longitudinal Sectional Drawings of the "Suckling" Water-tube Boiler.

from the last bank of tubes through a down take, in which a super-heater is fixed, to the chimney.

### Water-tube Boilers with Curved Tubes

Several forms of water-tube boilers have been worked out, in which the tubes are given various curved forms, and are usually of smaller

size than is common in those that have been described above.

#### The Climax Boiler.

—The most striking form of boiler with curved tubes is the Climax, made in this country by Messrs. B. R. Rowland & Co. It is shown in Fig. 16. The principal feature of the boiler is the small floor space it occupies, the apparatus being arranged vertically instead of horizontally. The arrangement of the water tubes also is peculiar to itself and, so far as the author is aware, is not like any other boiler. Further, the whole arrangement is unique. There is the usual steam drum, containing water and steam, as generated, but it is fixed vertically in the centre of the boiler. The water tubes look very much like a coil of rope, or one of the coils of taper that used to be used for sealing-wax in days gone by. There are a very large number of tubes, and they are bent into

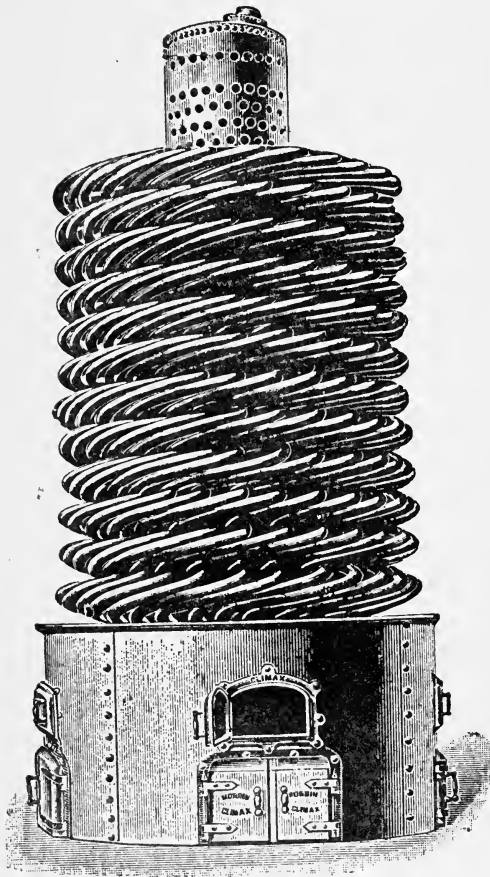

FIG. 16.—Internal View of Climax Water-tube Boiler, showing the Tubes, Vertical Steam Drum, etc.

the form of a loop, of a somewhat irregular shape, the form being necessary, as will be seen from Fig. 16, because each tube has to be

threaded in with the others. Each tube commences and ends in the central drum, but one end of each is always at a higher level than the other, and it will be understood that the water in the tubes is continually passing from each tube into the central drum, out into another tube, back to the drum, and so on. The upper portion of the central cylinder has also a series of diaphragms, which it is claimed form a series of superheating chambers, through which the steam is compelled to pass in its passage through successive loops of the tubes. The tubes are surrounded on the outside by a thermal insulating wall, and outside of that again is an iron casing enclosing the whole apparatus, the upper part of which is coned, its centre joining the chimney. The central cylinder descends right to the bottom of the structure, the bottom providing a space to which any sediment in the water can fall, and this portion of the cylinder being accessible by means of a manhole door. The water tubes are supported simply by their connection with the central steam drum, which is made of the usual steel of high tensile strength, welded longitudinally, in place of being riveted. Space is left below the lowest tube, sufficient for four furnaces, as shown in the figure, which are of the usual construction, with fire bridge, etc., at the back, and the hot gases from the furnace pass straight up between the interstices of the tubes, and over the surface of the central cylinder. The upper portion of the central cylinder is made dome-shaped, and forms the steam space, the steam pipe being connected to it. The conical space above the tubes is also made use of for the purpose of holding a feed-water heater, of somewhat novel construction.

The feed-water heater consists of a coil of pipe 100 to 300 feet in length, according to the size of the boiler, the pipe being from  $1\frac{1}{2}$  inch to 3 inches in diameter, and welded. This coil of pipe is fixed inside the conical space, above the water tubes. It surrounds the upper part of the central cylinder, and is therefore exposed to the heat of the hot gases as they pass to the chimney above. The feed water is passed into this coil of tube, and from thence to the lower part of the central cylinder, from which it passes to the lower tubes, thence circulating through successive layers of the tubes, becoming hotter as it passes upwards, steam being formed and disengaged in the central cylinder as the water passes into it from each tube in succession.

## The Thornycroft Water-tube Boilers

Messrs. Thornycroft's boilers have been designed principally for torpedo-boats, steam-launches, and similar work, but they are also used on shore. The principal feature in connection with them, is

the small size of the tubes, and the special arrangements that have been made for securing a large heating surface, and the passage of the hot gases over the whole length of the tubes. There are two principal forms made by the firm, known respectively as the Thornycroft-Marshall, and the Thornycroft-Schultz. In the Thornycroft-Marshall boiler, there are a number of tubes slightly curved, fixed to a header at the back, something on the lines of the central cylinder in the Climax, successive lengths of tube being connected together by connecting pieces at the front, two lengths forming together a loop, somewhat similar, though different in form, to the loop of the Climax boiler, and with a steam drum at the top in front, the drum being fixed at right angles to the line of the boiler. The tubes are staggered, and the furnace is below the lowest tube, the hot gases passing up simply through the interstices of the tubes to the chimney at the top, the water circulating in the tubes very much as in the Climax, steam being disengaged in the back header, and rising to the steam drum. This boiler is made also with straight tubes, arranged in a similar manner, in loops, as the curved tubes. It is also made in what is termed the sectional form. The tubes in the sectional form are all straight, one set of tubes of a section being inclined to the horizontal in one direction, and the other set of the same section being inclined to the horizontal in the opposite direction. Each set of tubes of a section are expanded into a front header, one below the other. The two sets of tubes are connected together by junction pieces at the back, in a similar manner to the tubes of the other boilers of this type. The furnace is below the lowest tubes, as before, the hot gases passing up between the tubes, and the steam drum being fixed in front of the boiler, at right angles to the line of the tubes, and connected to the header of the tubes which rise towards it.

### Thornycroft-Schultz Boiler

The Thornycroft-Schultz boiler, one form of which is shown in Plate 4B, was introduced by Mr. Thornycroft specially for marine work, and in particular for small craft, such as torpedo-boats, and torpedo-boat destroyers, where it is important to have the ability to raise a comparatively large quantity of steam in a small space, and to be able to raise steam very quickly. It is made in several forms, according to the vessel in which it is to be employed. The earliest form, shown in Fig. 17, was known as the "Speedy" type, and has three drums running fore and aft, two placed below, as will be seen, and the third above. The lower drums are for water, and the upper one is the steam drum. The upper drum is connected with the lower drums by a bank of small tubes, 1 to 1½ inch in



diameter, curved as shown. In the later forms of this boiler the tubes are only slightly curved, sufficiently to allow space between them, and make a nearly direct connection between the two drums, a large portion of the tubes entering the water space in the steam drum, and only a small portion entering it in the steam space. The steam drum is also connected to each of the water drums by the two large pipes shown. The small tubes are for the generation of steam, and the large tubes are for water circulation, to return any water carried into the steam drum back to the water drums, and also to convey the feed water, which is delivered into the lower part of the steam drum, to the water drums. The generating tubes are enclosed in a steel casing, as shown, lined with asbestos. This means that the whole of the boiler, except the front, where the large tubes are placed, is enclosed

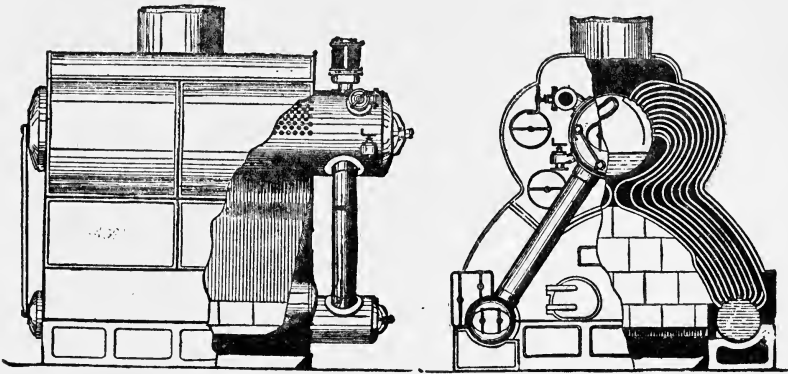

FIG. 17.—Longitudinal and Transverse Sections of the Thornycroft Water-tube Boiler, "Speedy" type.

within the casing. A small portion of the generating tubes also are formed into a sort of water-tube wall, the tubes being placed very close together, near the casing, and so enclosing the hot gases. The chimney rises from the middle of the casing, and the furnace is placed in the middle of the space at the bottom between the water drums, the hot gases, rising from the furnace, pass between the interstices in the tubes, round the steam drum, and thence to the chimney.

In the second form of this type of boiler, known as the "Daring" type, from the torpedo-boat destroyer in which it was first introduced, there are two drums, also standing fore and aft, but placed vertically one above the other, the upper one, which is much larger than the lower, is the usual steam drum, in which steam and water are present, and the lower drum is for water only. The boiler is shown

in Fig. 18. The two drums are connected by eight or nine large tubes, of about 4 inches in diameter, arranged practically in a vertical line between the two, and also by two sets of smaller generating tubes, curved in the forms shown, a portion of the generating tubes being placed close together, and forming a water-tube wall, as in the "Speedy" type. The whole is enclosed in a steel case as before, and there are two sets of furnaces, one on each side of the water drum, and the chimney rises from the rear of the boiler. The hot gases rise from the furnace, play over and through the generating tubes, and under and around the steam drum, and pass out by the chimney.

The launch type of boiler is described by Messrs. Thornycroft, as half a "Daring" type. There are the same two drums, the steam drum above, and the water drum below, connected by the large

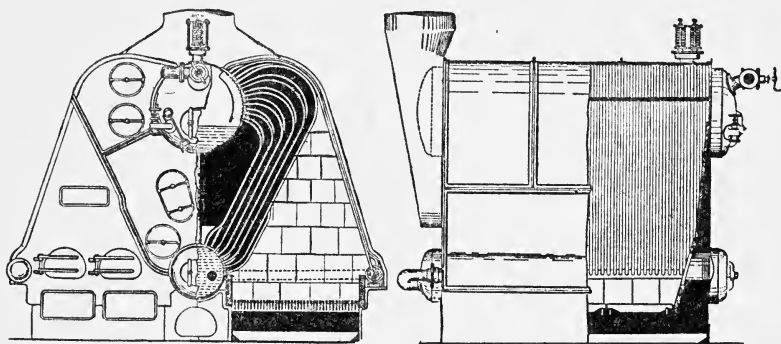

FIG. 18.—Transverse and Longitudinal Sections of the Thornycroft Water-tube Boiler, "Daring" type.

tubes, and by the two curved sets of small tubes, with the space between the two curved sets for the furnace, and for the hot gases to play. The whole is enclosed as before in a steel case, the chimney rising from the middle.

In the Schultz form of boiler proper there are four drums, one large steam drum above, and three water drums below, one immediately under the steam drum, and one on each side, and the steam drum is connected to the three water drums by curved tubes, a water-tube wall being formed on the outside of the outer bank of tubes, as in the others, and two furnaces being fixed between the centre water drum and the drum on each side of it. The whole is encased in a steel case, the chimney rising from the centre, as before, and the hot gases passing up from the furnaces playing round the generator and other tubes, and passing out to the chimney.

FIG. 2.

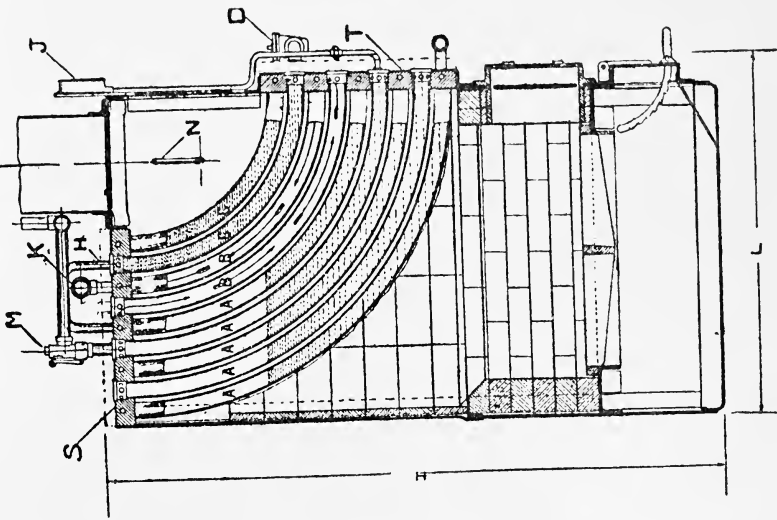

FIG. 1.

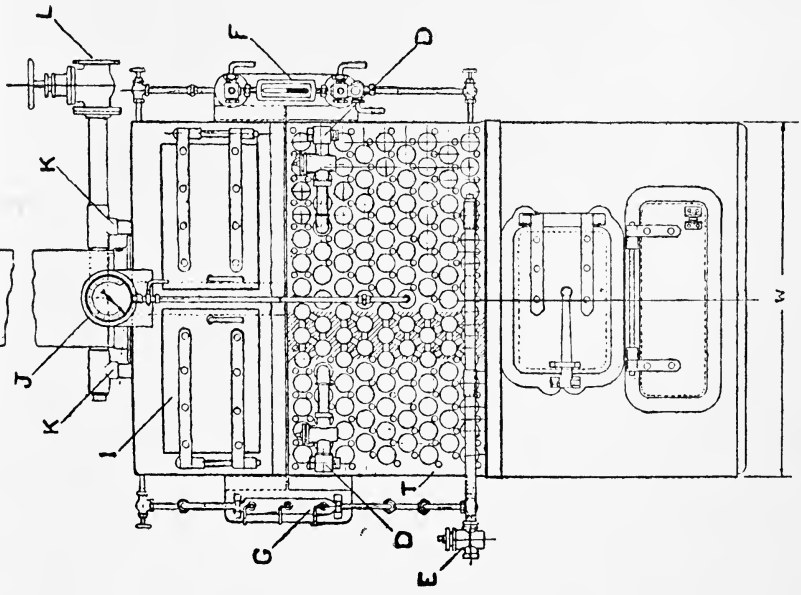

FIG. 19.—Transverse and Longitudinal Sections of the "Hay" Water-tube Boiler. A are Steam and Water-tubes; B, Drying and Superheating Tubes; C, Feed-water Heating-tubes; H, Pipes from Feed-heater to Boiler; S, Top-header; P, Bottom-header; K, Steam Collecting Pipe; N, Steam Jet.

## The Taylor Water-tube Boiler

This boiler, which is American, is made for marine engines, and, it is claimed, exposes a very large heating surface to the hot gases. The water tubes are of  $1\frac{1}{4}$  inch in diameter, and they are built into a rectangular form. They are formed into rectangular boxes by short lengths of vertical tubes, ending in horizontal headers, formed of pipes of larger section. The furnaces are underneath the lower bank of tubes, and the hot gases rise through the rectangular spaces, and play all round the walls of the tubes. Above the topmost box of tubes is the usual steam drum, and the whole is enclosed inside steel casing, the chimney rising from the centre.

Fig. 19 shows a transverse and longitudinal section of the Hay water-tube boiler that has recently been introduced, and is intended principally for marine work. Its principal feature is the curve given to the tubes, as seen in the figure, some of the tubes being used for steam, others for water.

## Small Vertical Boilers

There is a class of boilers made for small work, consisting usually of a vertical cylinder, made from open-hearth steel, in the same manner as the Lancashire boiler. They are used for portable and semi-portable engines, the engines being mounted on a bed plate, or on a wheel base by the side of the boiler, and are also used for those many cases where steam is employed for small industries, and in which very low pressure, 5 lbs., etc., are employed. They are made on both the water-tube and fire-tube plan. In both forms there are tubes fixed, sometimes horizontally across the boiler, sometimes vertically between the water and steam spaces. The furnace occupies the lower part of the cylinder, the grate bars being fixed sufficiently above the ground to allow for an ashpit underneath, and the chimney sometimes rises from the centre of the cylinder, and sometimes from the side. In either case the hot gases pass around the tubes, when they are water tubes, and through them when they are fire tubes, and find their way to the chimney.

Boilers for motor-cars, motor-waggons, etc., steam-driven waggons, lorries, etc., have special forms. They are sometimes fired with coal, preferably anthracite, but more frequently with either petrol, paraffin, or one of the oils obtained from the distillation of petroleum.

The Thornycroft Steam Waggon Company, and Messrs. Straker, have both worked out forms of boilers for use with anthracite or

coke. The Straker boiler, which is shown in Fig. 20, is a water-tube boiler, constructed something on the lines of the Climax, but without the curved tubes that are such an important feature in that boiler. There are four concentric tubes fixed vertically, and between two of them, as shown, are fixed cross tubes radially, and slightly

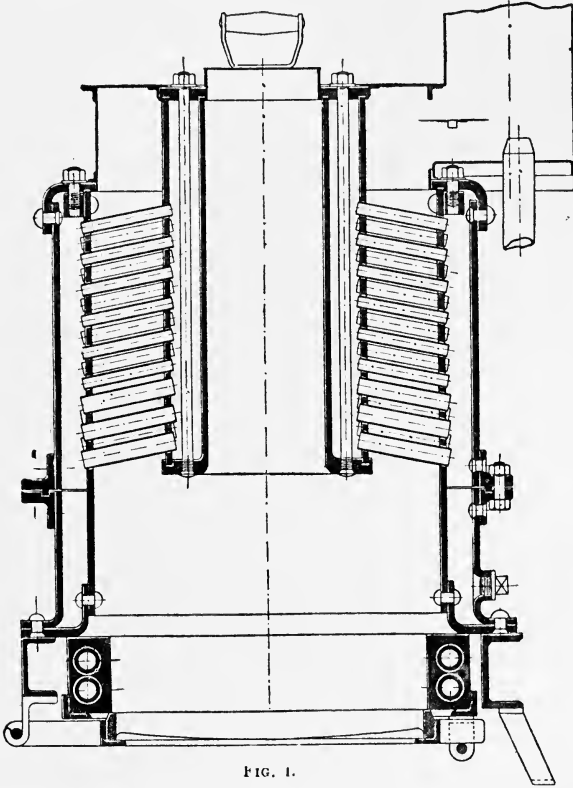

FIG. 1.

FIG. 20.—Sectional Elevation of the Straker Boiler for Steam-driven Vehicles. The water is in the tubes, and the hot gases pass up between them.

inclined from the centre outwards. The bottom portion of the apparatus forms the fire-box, with an ashpit below, and it is fed from above, by way of the central tube; the radial tubes are placed in echelon, the effect being the same as the staggering of the tubes in ordinary water-tube boilers, and the hot gases pass up through the spaces between the tubes, and thence find their way to the chimney.

The Thornycroft boiler is also of the water-tube type. It consists

of two annular chambers, fixed horizontally one above the other, the two being connected by a number of small straight steel tubes. The furnace is below, as in the Straker, and the hot gases pass from it round the tubes, and the underside of the upper annular ring, and find their way to the chimney. Of the oil-fired boilers for motor-cars, waggons, etc., the White, an American apparatus, is perhaps the best known. The arrangement of the boiler is shown in Plate 6B. The boiler, it will be seen, consists of a coil of tubes, the burner being of the ring form, with a special arrangement for carburizing the oil as it comes from the burners. The action of the burner is very similar to that of the ordinary gas-ring burner, so well known, with the addition of a provision for warming the oil on its way to the burner, for the purpose of vapourizing it. The water for the boiler is fed into the upper end of the coil, passing downwards from section to section, and before it has reached the point at which it is taken off to the engine, it has become steam, and has been thoroughly dried and superheated, this being one of the special features which enables the boiler to be worked successfully.

In the Turner-Miesse, which is made in England, the boiler, or generator, as the makers of motor-cars prefer to call it, consists of layers of zigzag coils of pipe, fixed at right angles to each other, inside a casing, and with a burner underneath. The water in this case enters the boiler in the lower layers, but after being converted into steam, is brought down again to some of the intermediate layers, those at right angles to the water layers, where it is dried and superheated before being passed to the engine.

## CHAPTER III

### BOILER ACCESSORIES

#### Burning the Fuel

**The Furnace Grates.**—Except in the case of some special boilers where liquid fuel is burned, and of some others that will be described, the grates of all boilers are very much alike. They are merely horizontal platforms, built of sectional pieces of iron, arranged to hold the fuel in such a manner that air can pass up from the ashpit into the fuel, and the ashes can pass down into the ashpit. The usual length of the fire grate from back to front is 6 feet, and it is generally formed of two sets of fire bars made of cast-iron, supported in front by bars resting on the dead plate, and at the back by other bars resting on the bridge, the supporting bars having slots into which the ends of the fire bars fit. At the middle of the furnace the fuel bars are supported in a similar manner by a bearing bar.

In nearly all furnaces there is the fire-brick bridge at the back, that has been referred to so often in the course of the previous chapter, the office of which is to enable the fire to be built of a certain thickness, to form a sort of holder for the front portion of the fire, and by itself becoming white hot, to assist in the combustion of the hydrocarbon gases, the finely divided carbon, etc., that so often comes away from the fuel unburned.

In the Lancashire and Cornish boilers, the marine boiler, and in those multitubular boilers which are internally fired, the fire grates occupy the front portions of the flues. In the water-tube boilers the fire grates occupy the front of the large rectangular space enclosed by the brickwork, as described. In the Lancashire and Cornish and other internally fired fire-tube boilers, the lower portion of the flues, in which the fire grates are fixed, form the ashpits, and it is through these that air enters the boiler, and through them that the ashes, clinker, etc., are drawn out.

In the water-tube boilers the ashpit is practically on the ground,

protected from fire, etc., and the back portion of the rectangular space enclosed by the brick and steel structure is often employed as a combustion chamber, and it is sometimes arranged that the ashes fall over the back of the furnace, into the space below, or into a chamber provided for them.

The fronts of all furnaces are closed by one or two fire doors, the ashpits being sometimes closed and sometimes not. As will be explained, with what are termed natural and induced draught, the ashpit is left open for the air to pass in under the fire bars, and thence through the fuel. With one form of forced draught the ashpit is closed, and the air is forced into it through a pipe provided for the purpose.

The furnace doors are sometimes single and sometimes double. They sometimes swing on hinges, and sometimes slide along the face of the boiler, in a similar manner to bulkheads on board ship, the two doors opening and closing together, and being kept in position by balance weights.

### • Special Forms of Furnace Bars

Several special arrangements of furnace grates have been introduced, with the object of cleaning the fires quickly, without opening the furnace doors, and to maintain a more constant draught than is sometimes possible with the ordinary bar.

It will be understood that with the ordinary bar, built into a grate, with practically all kinds of fuel, the spaces between the bars are gradually filled up by the incombustible clinker that is formed from the coal, and this results, first in a reduction of the draught, or, to put it more correctly, in an increase of the resistance to the passage of the air into the fuel, and later on, to the necessity for cleaning out the fires in order to get rid of the clinker; as, if the clinkering is allowed to go on, the apertures between the bars will be completely stopped up. It is to avoid this that the moving bars in all forms of mechanical stokers are employed, the clinker, as described later on, being automatically carried to the back of the furnace. The special forms of furnace bars to be described aim at accomplishing the same object, without the automatic feeding which constitutes the special feature of mechanical stokers. In Fig. 21 Neil's rocking fire bars are shown in a complete grate 6 feet long by 3 feet wide, built up of two sets of fire bars, longitudinally, each set comprising five bars fixed side by side. The *modus operandi* is as follows. The fuel is fed on to the fire bars in the usual way, and is allowed to burn for a certain time, and when the boiler-attendant considers it necessary—this point is, of course, determined by experience—the handle shown



on the left is moved, and the whole of the bars rock quickly on their axes, allowing the clinker to fall into the ashpit below. Mr. Neil also makes a fire grate with a special furnace door, as shown in Fig. 22, leaving a baffle plate between the furnace front proper and the front of the grate, the dead plate being in front of the baffle plate. The object of the baffle plate is to protect the furnace door, and its brackets, from the flames of the furnace, and also to heat auxiliary air that may be allowed to pass over the fuel for the purpose of quenching smoke. It will be seen that any air which passes through the furnace door has to pass through the holes in the hot baffle plate before reaching the furnace. It will be noticed that there are air spaces in the fire bars, the adjacent bars being fitted very closely together.

In another form of rocking fire grate, made by the E. Keeler Company of Williams Port, Pennsylvania, the fire bars are arranged in rows, at right angles to the line of the furnace. Each fire bar is in the form of a crescent, fitting on the spindle common to its row, and the whole of

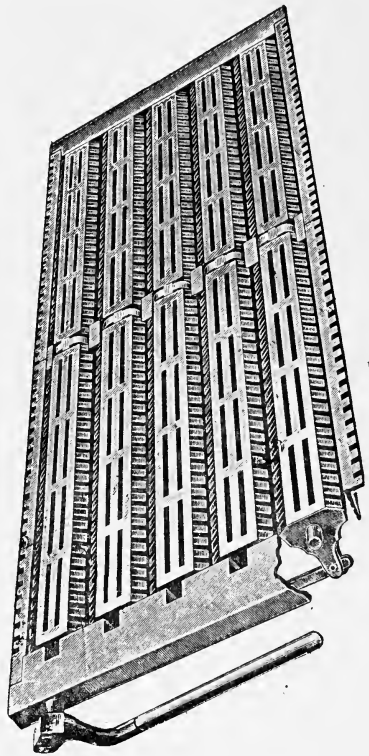

FIG. 21.—Furnace Grate with Neil's Rocking Fire Bars.

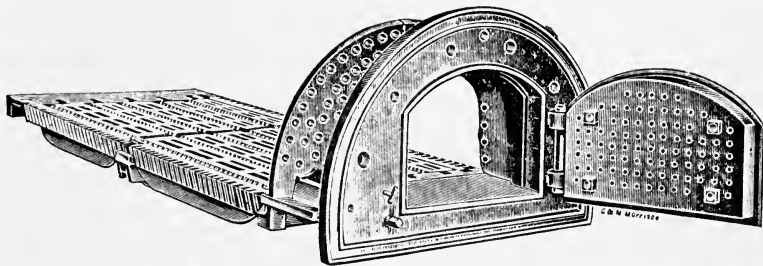

FIG. 22.—Neil's Furnace Front, with Baffle Plate between the Furnace and Fire Door.

back, so that the clinker is automatically thrown downwards by the

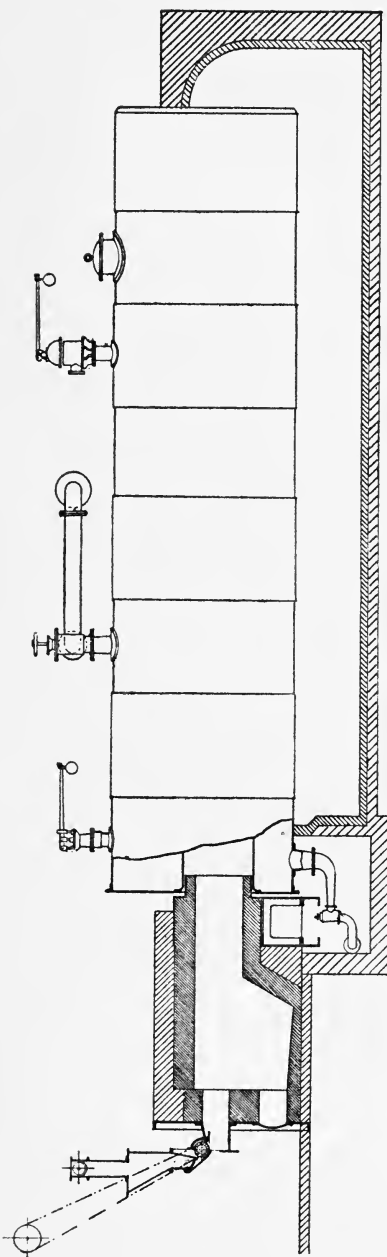

Fig. 23.—Sectional View of Arrangement for burning Coal Dust, in a Lancashire Boiler, by the Schwartzkopff Process. The Hopper is shown on the Left, and the Revolving Brush which delivers the Coal Dust into the Furnace below it.

action. The Keeler Company also make a grate bar, built up of a number of V-shaped bars, held between two parallel sides, the whole being cast in one, the spaces between the V's allowing air to pass up into the fuel.

There is another form of rocking fire bar, made by Messrs. Neemes Bros., of Troy, New York, that is very similar to the Keeler, but with a space between the bars.

### Apparatus for Burning Coal Dust

Coal dust may be burnt in Messrs. Meldrum's furnace, described on p. 114, or it may be burnt by special apparatus, such as that worked out by Mr. Schwartzkopff and that known as the Cyclone apparatus. With either of these apparatus the coal is first reduced to a very fine powder by the aid of machinery designed for the purpose, and is then delivered to the furnace in the form of a fine spray, similar to the spray formed from petrol in motor engines. The object to be attained, in both cases, is the division of the substance into very fine particles and the spreading of the particles into the air that is supplied to the furnace, so that each particle

of dust can seize upon the oxygen it requires to complete its combustion.

In the Schwartzkopff apparatus, which is shown in section in Fig. 23, the coal dust is taken to a hopper above the entrance to the furnace, and is led down into the furnace by a revolving brush, as shown, which spreads the dust out, and delivers it in a fine cloud into the furnace, very much as petrol and air are delivered to the cylinder of a motor-car engine. Induced draught is employed with the apparatus, and the combined operation of the brush and the sucking action of the induced draught provides a continual supply of air and fuel to the furnace.

In the Cyclone apparatus the coal dust is taken to a hopper, as with the Schwartzkopff, but it is delivered to the furnace solely by the aid of the fan that is employed to furnish the draught, forced draught being used.

## Apparatus for Burning Liquid Fuel

**The Holden System.**—In the Holden apparatus, which is arranged for burning liquid fuel, either separately or in conjunction

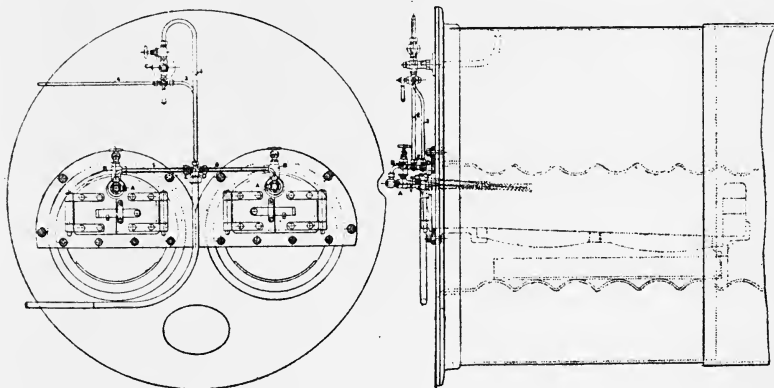

FIG. 24.—Sectional Drawings of Holden's Apparatus for Burning Liquid Fuel, as applied to a Lancashire Boiler.

with solid fuel of an inferior quality, and for burning the fuel in the strictly liquid form, or in the form of the pasty mass known as refuse, a steam injector is employed. The apparatus is applicable to all kinds of boilers, though it was worked out originally for use with the boilers of locomotive engines. The liquid fuel is held in any convenient receptacle near, and is led to the fire-box by a pipe, as shown in Fig. 24, and is forced into the fire-box, or combustion

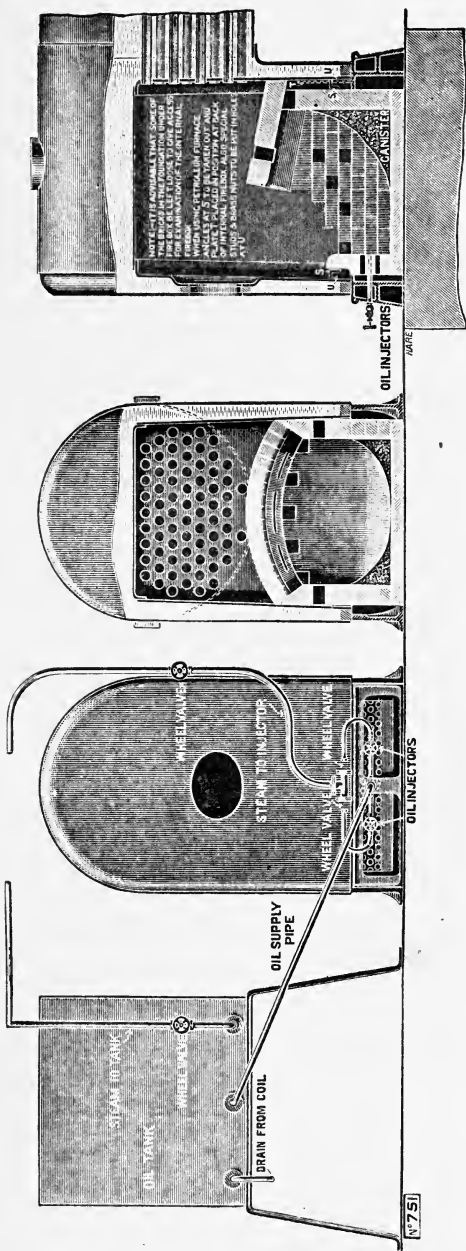

FIG. 25.—Marshall's Apparatus for Burning Liquid Fuel, as applied to a Multitubular Boiler. The Two Figures to the left show the Oil Tank and its connection to the Ashpit; the other Two Figures are Transverse and Longitudinal Sections of the Boiler, showing how the Oil Feed and Steam Jet are applied.

chamber, in the form of a fine spray, by the aid of a steam injector. The injector forces the fuel into the fire-box in the same manner as water is forced into the boiler.

Where a low-grade fuel is employed in addition to liquid fuel, a thin layer of the fuel is laid on the fire bars, and the jet of liquid fuel is directed on to it.

In this apparatus, as in other forms of liquid fuel burning apparatus, the furnace forms a combustion chamber, the fire bars merely being employed to supply the necessary air to combine with the carbon and hydrogen of the fuel.

The apparatus is applied to Lancashire and other boilers, by merely cutting a hole in the door of the furnace, and inserting the pipe and injector nozzle. Proper cocks regulate the supply of fuel and steam. Steam for the injector is taken from the boiler.

### Liquid Fuel Burners

Marshall's Apparatus.—Messrs. Marshall & Sons, of

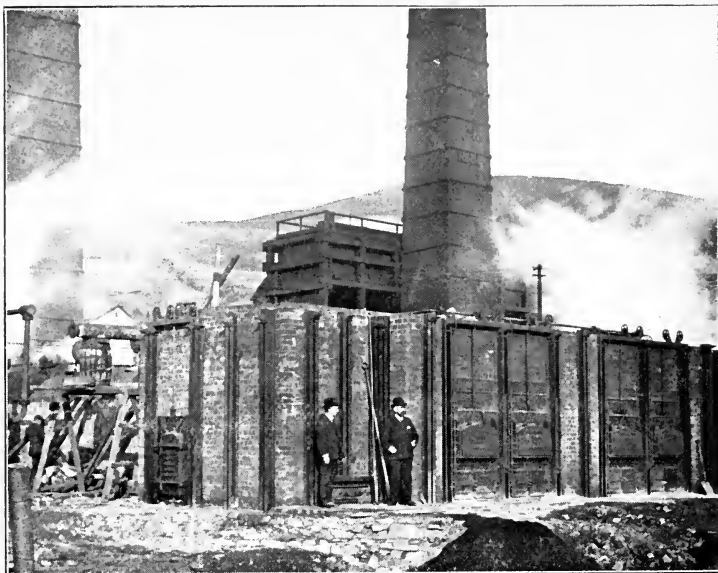

PLATE 7A.—Outside View of Medrum's Furnaces for Low-grade Fuels, as fitted at a Colliery. The Boilers are at the back, their Flues being connected to the Furnaces.

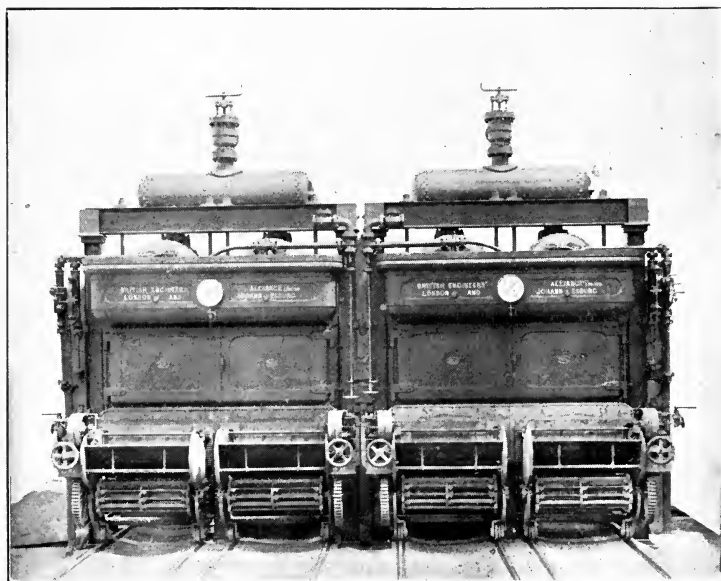

PLATE 7B.—A Pair of Water Tube Boilers, with Chain Grate Stokers.  
[To face p. 112.]



Gainsborough, have also worked out an apparatus for burning liquid fuel that can be applied to boilers of any type. The fuel is carried in a galvanized iron tank, standing near the boiler in which it is to be consumed, and the tank is warmed by a copper coil, through which steam passes from the boiler, the condensed steam being carried off in the usual way. Warming the fuel renders it more easily handled, and enables the pasty substances mentioned to be handled as liquids.

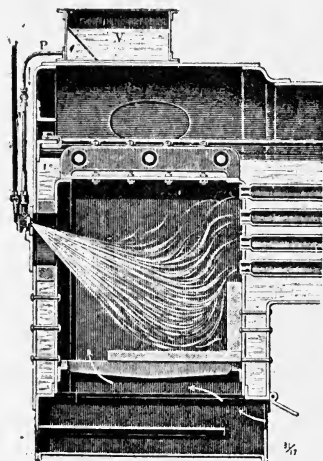

FIG. 26—Korting's Liquid Fuel Burning Apparatus, applied to a Locomotive.

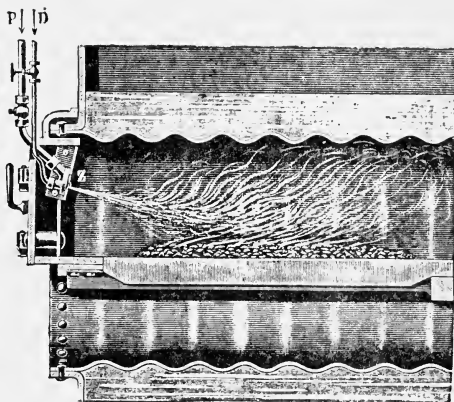

FIG. 27.—Shows its application to a Lancashire Boiler.

The fuel is driven into the furnace, under the fire bars, in a manner very similar to that described with the Holden apparatus, by means of an injector. As shown in Fig. 25, a pipe from the fuel tank leads to the ashpit of the boiler, and a steam pipe from the boiler leads there also, the injector driving in the fuel into the furnace in a fine spray, as already described. Figs. 26 and 27 show Korting's liquid fuel burning apparatus.

## Burning Town's Refuse

Town's refuse has a small calorific value, since a large portion of the material of which it is composed contains a certain quantity of carbon, though there is also a very large proportion of incombustible material. Its average evaporative value is about 1 lb. of refuse to 1 lb. of water evaporated from, and at 212° F. the average evaporative duty of coal being 8 lbs. Refuse, it will be easily understood,

varies very considerably, some of it in certain districts having a value only half the average, and some in other districts having a value of twice the average.

There are several refuse destructors on the market, all on certain lines, with the usual variations. In all of them there is a furnace—a modification of the ordinary boiler furnace—with usually some arrangement for drying the green refuse, the freshly deposited refuse, before it is pushed on to the furnace bars proper. There is also in all forms of the apparatus either a chamber or a special flue, whose walls are maintained at a very high temperature, so that the green gases, as they are called, the gases which are produced by the first combustion of the refuse, are submitted to a temperature of 1500° to 2000° F. in this chamber or flue. The reason for this is, unless this is done, the smoke and gases that are emitted from the chimney may be a nuisance to the neighbourhood, as they contain substances that will form, with the bacilli in the neighbourhood, noxious products that give rise to disease, etc. In addition, in all forms of the apparatus, there is some arrangement for creating forced draught, and usually for warming the air before it enters the furnace, a steam jet being a favourite form of draught-producing apparatus, and the hot gases, after passing through the high-temperature chamber mentioned being caused to warm the air passing to the furnace by a system of pipes similar to those described on p. 162 in connection with Green's apparatus. In all of them also some appliance is necessary for depositing the large quantities of dust that are formed in the process of combustion, and preventing them passing out to the atmosphere outside. In the Horsfall apparatus there is a whirling chamber at the base of the chimney, in which the dust is carried into side-depositing chambers by centrifugal force. In Meldrum's and other apparatus there are settling chambers of different forms. The hot gases, after passing through the combustion-chambers mentioned, are led to boiler flues in the usual manner, the refuse-destructor combustion chamber being directly connected to the boiler flues or the space for the gases in the water-tube boiler.

### Meldrum's Colliery Refuse Destructor

Messrs. Meldrum, who have fitted up a number of refuse destructors for town's refuse, have also worked out a modification of their refuse destructor for burning the inferior fuel that is so often found in collieries on the margin of the coal seams and sometimes between them. The substances mentioned are unsaleable on the market, as their calorific value is so low, but when applied in the manner described, they answer very well for raising steam.



In Messrs. Meldrum's apparatus, an external view of one of which is shown in Plate 7A, the principal feature is the grate, in which the bars are made very thin, and placed very close together, as shown in Fig. 28, and the draught is produced by Messrs. Meldrum's method of steam injection, as explained on p. 147.

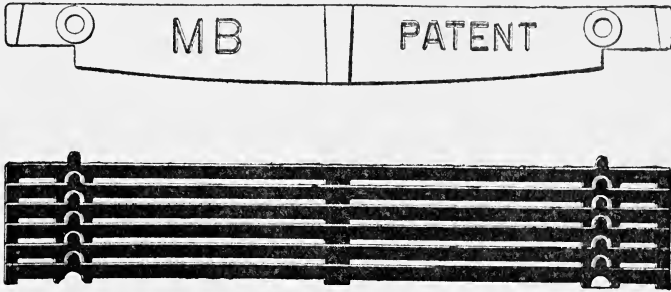

FIG. 28.—Section and Plan of Meldrum's Interlocking Fire Bars, for burning refuse fuel. The bars are thin and very close together.

At the back of the furnace is a combustion chamber, very much on the lines of that employed in town's refuse destructors, in which the hydrocarbons and all combustible matter coming over from the furnace are burned, and this is directly connected with the boiler flues or the gas space of the water-tube boiler by a special flue connection. The whole arrangement is shown very clearly in Fig. 29.

## Mechanical Stokers

The object of the mechanical stoker is to perform the work that is done by the human stoker more uniformly, and, in addition, without the continual opening of the furnace doors that are necessary with hand firing. It was explained in previous pages that the air entering a furnace above that required for actual combustion has to be raised to the temperature of the hot gases, abstracting a certain quantity of heat from the hot gases in the process. When the furnace door is frequently opened a certain quantity of cold air passes into the furnace each time, and this air not only has to be heated to the same temperature as the other gases, but it has the same effect, in a minor degree, as throwing water upon burning fuel—it tends to damp the fire. Hence properly designed mechanical stokers should avoid the undoubted heat losses from this cause. It is found also that with mechanical stokers very much lower grades of fuel can be employed; and further, when combined with one of the systems of

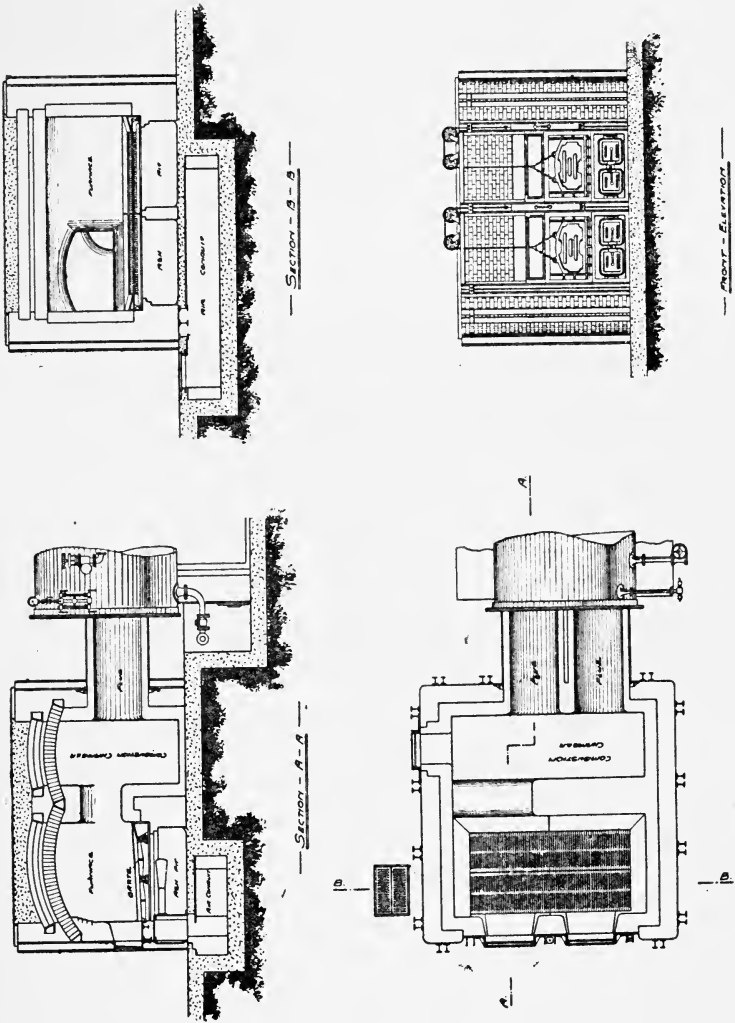

FIG. 29.—Sectional Drawings showing Messrs. Meldrum's Low Grade Fuel Furnace. The longitudinal section AA and the plan show the general arrangement of the Furnace, Combustion Chamber, and the Flues connecting the latter with the Boiler Flues. The front elevation shows its appearance from the Boiler House, or Firing Platform, and BB is a transverse section.

mechanical draught, a larger quantity of fuel can be burned in a given time. It is also claimed for mechanical stokers that they provide smokeless combustion. The ordinary rate of combustion with chimney draught is in the neighbourhood of 15 lbs. of fuel per square foot of grate area. With mechanical stokers and with mechanical draught, it is claimed that the rate of combustion can be raised to as much as 60 lbs. per square foot of grate area. It must be understood, however, that the rate of combustion will vary with the class of fuel, and that increased draught, and the absence of admission of cold air, will increase the rate of combustion of every class of fuel.

### Forms of Mechanical Stoker

Mechanical stokers may be divided broadly into two classes, known as over-feed and under-feed. The names practically describe

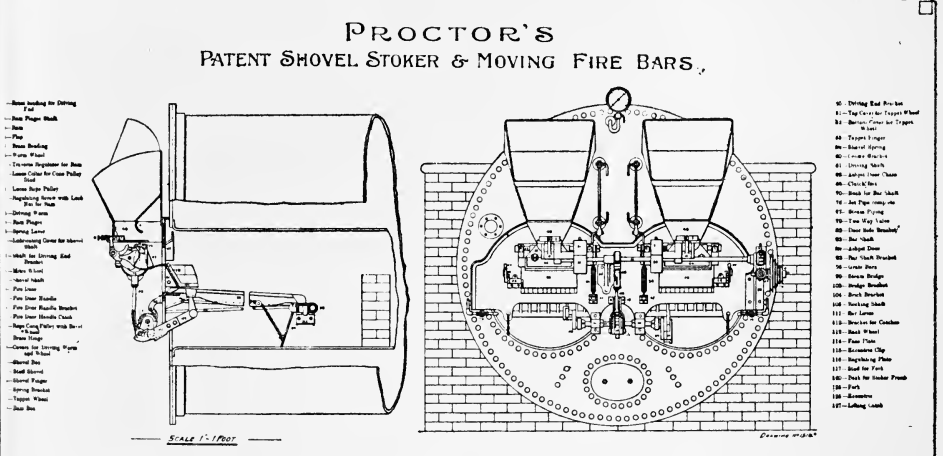

Fig. 30.—Longitudinal and Transverse Section of Lancashire Boiler fitted with Proctor's Shovel Mechanical Stoker. The Coal is fed from the Hoppers into the Boxes below, and is thence ejected on to the Fire Bars by the action of the Swing Shovel.

them. In the over-feed stoker the fuel is delivered from above, on to the upper surface of the furnace bars. In the under-feed stokers, the fuel is brought from below, and is worked up through openings between the bars, as will be explained, on to their upper surfaces. All over-feed mechanical stokers also are broadly divided into two classes, known as coking and sprinkling. Some forms combine the two. The broad distinction, however, is, in the coking stoker the

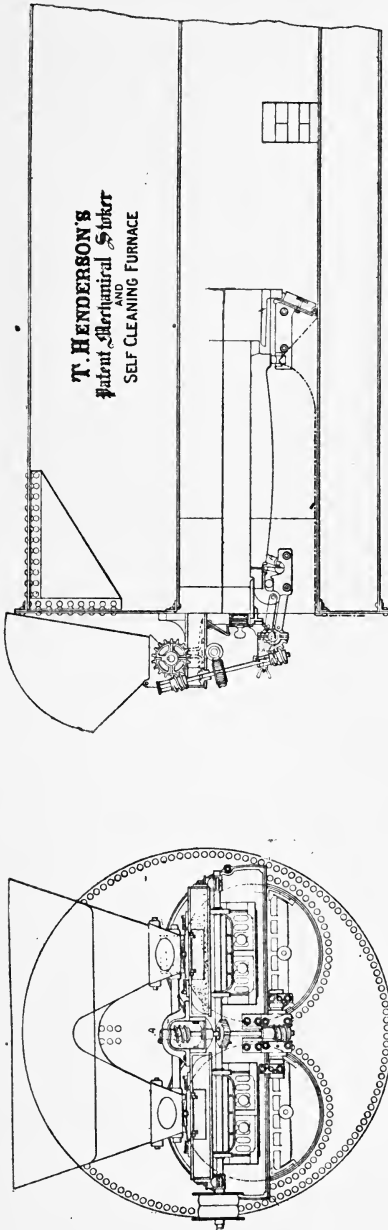

FIG. 31.—Transverse and Longitudinal Section of Henderson's Mechanical Stoker.

fuel is delivered in small quantities periodically on to the dead plate, or the front of the furnace bars, and is there allowed to form into a pasty mass, coking together very much in the same manner as small coal does in a coke oven. After it has coked, it is pushed forward on to the front of the furnace bars, another charge taking its place at the coking position, and it is gradually pushed forward as each charge enters the furnace, and finally is usually ejected into a chamber at the back of the furnace.

In the sprinkler stoker, small quantities of fuel are thrown on to the furnace bars at intervals, the fuel being sprinkled over the whole width of the bars, and the whole burning mass being gradually worked forward by motions of the furnace bars.

In all forms of mechanical stokers there is a hopper holding about 3 cwts., conveniently fixed in front of the furnace, at different heights, according to whether the stoker is over-feed or under-feed, and the fuel is delivered into the hoppers by conveyors, and occasionally by hand. The bottoms of the hoppers all have valves, or other arrangements controlling the admission of fuel to the

furnace. In the sprinkler stoker the fuel is cast on to the fire bars by the action of what is termed the shovel. One form is shown clearly in Fig. 30, which is a section of the Proctor mechanical stoker. The shovel, it will be seen, is a plate hinged above, and worked either by a spring or a cam, or other arrangement. A charge of fuel is delivered in front of the shovel, and at stated intervals, which can be regulated from the front of the boiler, the shovel plate moves quickly forward, and throws the fuel in a shower on to the furnace bars. In the Proctor stoker the shovel moves radially. In other forms it moves merely horizontally. In one form, the Henderson, there is a revolving shovel, shown in Fig. 31. In all forms of sprinkler stokers it is arranged that the fuel shall be thrown to different parts of the furnace, by varying the throw of the shovel, this being accomplished by the action of the gearing on the outside. Thus, taking the grate bars as six feet in length, one throw would be nearly to the end of the bars, another one to about  $4\frac{1}{2}$  feet, another to about 3 feet, and so on. Plate 8A shows a Proctor's mechanical stoker complete.

The coker stokers are all fitted with some form of ram, or pusher, as it is sometimes called, which pushes the fuel usually from the dead plate on to the front of the bars, the moving bars carrying it forward.

It is claimed for the coker stoker, that the green gases, as they

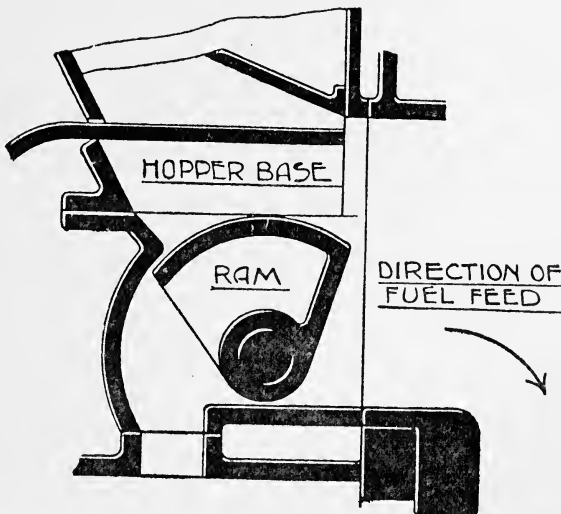

FIG. 32.—Section of Ram and Hopper of Meldrum's Coker Stoker.

are termed, the hydrocarbons, and the coal dust which comes away freely from freshly fed coal, has to pass over the mass of burning

coal in front of it, and is consumed, and therefore there is no tendency for it to make smoke. Fig. 32 shows a section of the ram and hopper of Meldrum's coker stoker.

## The Grate Bars of Over-Feed Stokers

The grate bars of over-feed stokers are arranged on two main lines. In one form—in which are included the Bennis, the Proctor,

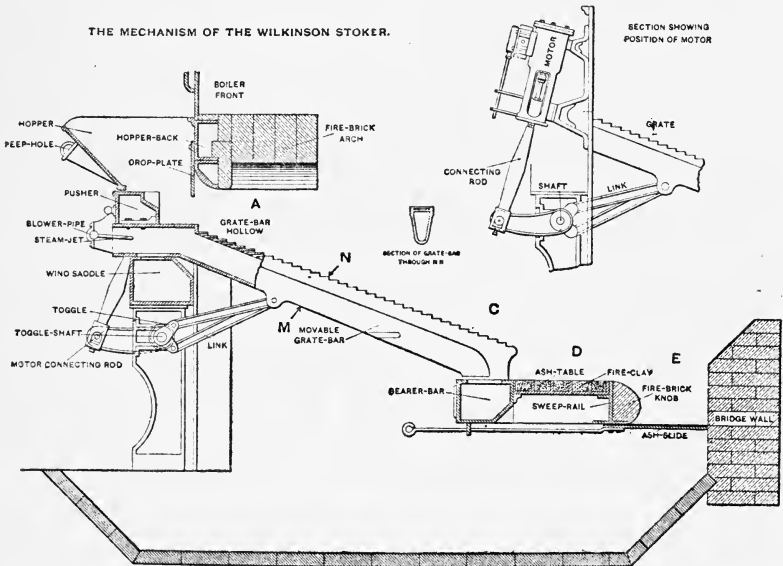

FIG. 33.—Mechanism of the Wilkinson Mechanical Stoker. The Bars are arranged as Steps, as shown, Steam passing out through the ends of the Bars.

the Vicars, the Hodgkinson—the bars stand side by side, and alternate bars are moved upwards and forwards at intervals, returning to their normal positions when the other bars move forward, this motion of the bars giving the forward motion to the fuel. In another type of the straight-bar stokers, the bars are given a jerking motion at intervals, which has the same effect.

The furnace bars are also sometimes all moved forward together, and withdrawn singly, and in other forms moved forward singly, and withdrawn together. In some forms of stoker also—notably the Bennis, and the Wilkinson, an American stoker—the grate bars, or a portion of them, are made hollow, and a steam jet is fixed at the front of each bar, the air supply to the furnace being furnished by

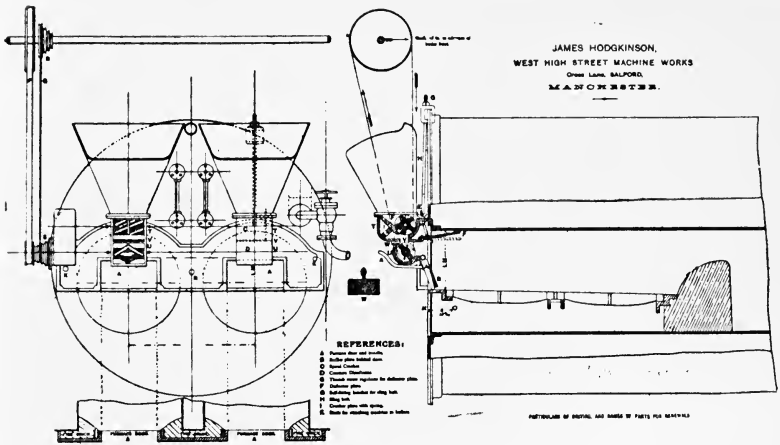

FIG. 34.—Transverse and Longitudinal Section of Hodgkinson's Mechanical Stoker.

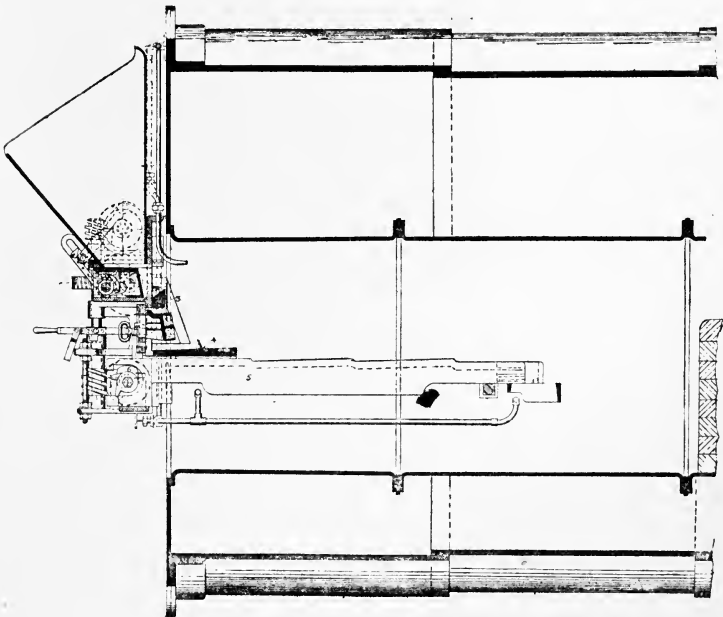

FIG. 35.—Longitudinal Section of a Mechanical Stoker fitted to a Lancashire Boiler.

the steam jets, and therefore the bars themselves. It is claimed for this arrangement, that the bars can be fixed very close together, so that very small fuel can be burned, and that the draught is evenly distributed over the whole of the furnace, and is under control, by the steam jets. In some forms of this apparatus the steam jet is automatically controlled by the output of the boiler. When the boiler is furnishing steam rapidly, the steam jet passes a comparatively large quantity of steam, and *vice versâ*.

In the Wilkinson Stoker also, as will be seen from Fig. 33, the fire bars are made in the form of steps, inclined downwards towards the back of the furnace, alternate bars being moved to and fro, as explained above, and the fuel is carried down from step to step, to an ash table at the bottom, where the whole of its combustible matter is finally consumed, and the remainder then passes over on to the ash slide shown, between the ash table and the fire bridge, and is allowed to fall into the ashpit periodically, by withdrawing the slide. In this furnace also there is a fire-brick arch over the front portion.

In the Bennis stoker the bars are inclined upwards towards the back of the furnace, and the fuel travels up the incline, and is then tipped over into the chamber at the back, as explained. Fig. 34 shows the Hodgkinson's mechanical stoker, and Fig. 35 another form.

## The Auto Stoker

This apparatus, which presents certain features that are of interest, and is made by the Union Ironworks Co. of Ashton-under-

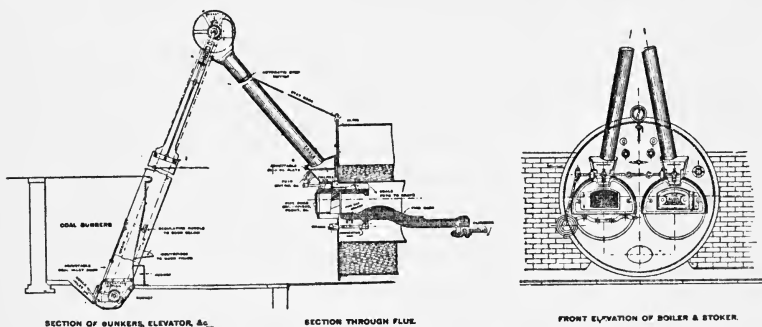

FIG. 36.—Longitudinal and Transverse Sections of the "Auto" Stoker.

Lyne, is shown in Fig. 36. There are the usual hoppers over the furnaces, from which the coal passes on to the fire bars, but the hoppers are supplied from bunkers in the boiler-room, by the bucket



elevators shown, which deliver the coal to the shoots above the hoppers.

The bunkers are placed in the position where coal is usually heaped for hand firing, and, as will be seen, if anything happens to the automatic gearing, hand firing can be immediately resorted to, the bunkers having the slides shown, at the foot, through which coal can be taken by the firemen.

The fire bars are of the special form shown, and the coal is first pushed by the ram from the feed box on to the convex portion of the bars. From the convex portion of the bars, the fuel passes forwards, carried by the motion of the bars, and a mass of fuel at a very high temperature is formed in the concave portion just beyond, the hydrocarbons and dust brought in with the fuel having to pass over this hot zone, and, it is claimed, being completely burnt.

The ashes and clinkers are pushed over the ledge at the back of the furnace, in the manner described in connection with other forms of mechanical stokers.

All the fire bars move to and fro, but only four of the bars in each apparatus receive motion directly from the driving shaft. The remaining bars are keyed to the four driving bars, and receive motion from them.

The four bars are driven by short connecting rods from a crank shaft in front of the boiler.

## Vicars Mechanical Stoker

In the Vicars mechanical stoker, a sectional drawing of which is shown in Fig. 37, there are the usual hoppers, and the coal passes from them into boxes, usually two for each flue of a Lancashire boiler, from which it is pushed by reciprocating plungers or rams, working alternately, on to the dead plate, where it is allowed to remain for a short time, to facilitate coking. From the dead plate it is pushed on to the moving fire bars, where it is carried forward in the usual way by their motion. The arrangements at the back of the furnace are a little different to those in some of the other stokers: the fire-brick bridge is built a little distance back from the ends of the fire bars, and the fuel is allowed to fall over in a mass on the bottom of the flue, as shown in the drawings, so that no air can pass from the under side of the bars to the front of the furnace. The space between the bridge and the front of the fire bars forms the usual combustion chamber, and the clinkers are removed at intervals. The whole of the fire bars move forward together, and alternate bars are moved backwards at intervals, it being claimed that this action is best for carrying the fuel forward.

For water-tube boilers the arrangement is slightly different. There is a second set of inclined bars, on to which the fuel falls from the end of the fire bars, and it is gradually pushed from them forward into the pit below, a mass of burning fuel accumulating there, preventing the passage of any air past it to the front of the furnace, from below, and providing the combustion chamber.

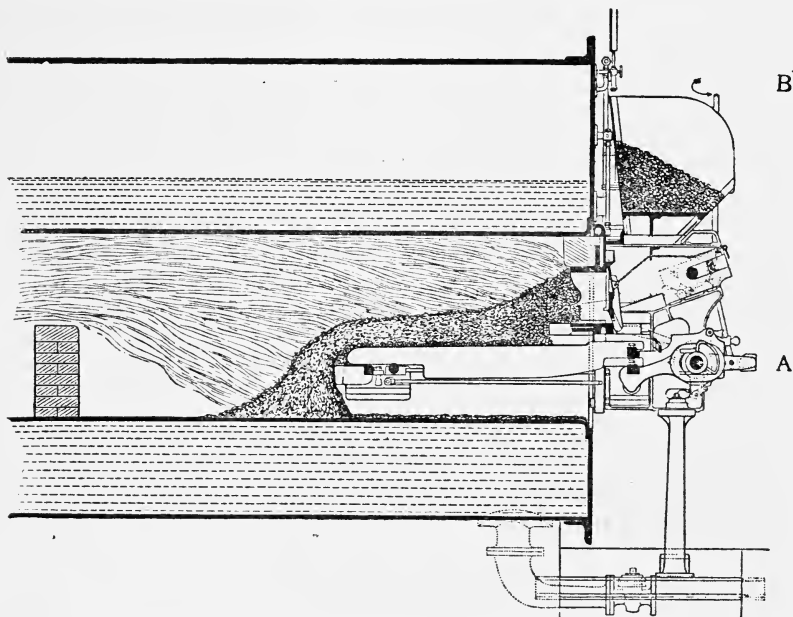

FIG. 37.—Longitudinal Section of Lancashire Boiler fitted with Vicars Mechanical Stoker.

The stroke of the plungers forming the feed can be regulated from the front of the boiler at will, and also the stroke of the fire bars. The whole of the feeding plant is supported from the floor, and not from the front of the boiler.

### Chain-Grate Stokers

In the other type of over-feed stoker, the furnace bars are made in the form of an endless chain, the bars forming links of the chain, and the chain itself passing over drums at the front and back of the furnace. The chain is kept continually in motion by the revolution of the front drum, this causing the forward motion of the fuel. The fuel is delivered from the hopper on to the furnace bars immediately

below it, over the whole width, the amount of the feed being regulated by valves or doors at the bottoms of the hoppers, lifting vertically at certain periods, as with the other forms. The fuel travels slowly forward as the grate moves, and the ash and clinker is delivered to a chamber at the back, as in other forms. The front drum is driven by worm and wheel gearing, with a ratchet and pawl attachment, by means of which the rate of travel of the grate can be adjusted, and the height to which the valve or lifting fire door moves, can also be adjusted.

In the Babcock and Wilcox chain-grate stoker which is shown in Plates 8B and c, the whole apparatus is arranged to run on rails into the furnace space in the Babcock boiler. The rails which are shown in the illustrations, accommodate the wheels of the truck forming the carriage of the stoker, and the whole thing can be run out at any moment for repair and quickly run in again. It is claimed that repairs can be made to the grate, however, without moving the stoker out of its place, by merely running the chain back till the defective bar is exposed. Plate 7B shows a pair of water-tube boilers fitted with another form of chain grate stokers, in which the links are half the width of the stoker.

## Under-Feed Stokers

In the under-feed stoker, as explained, the fuel is contained in a magazine or reservoir, as shown in Figs. 38 and 39, carried under the

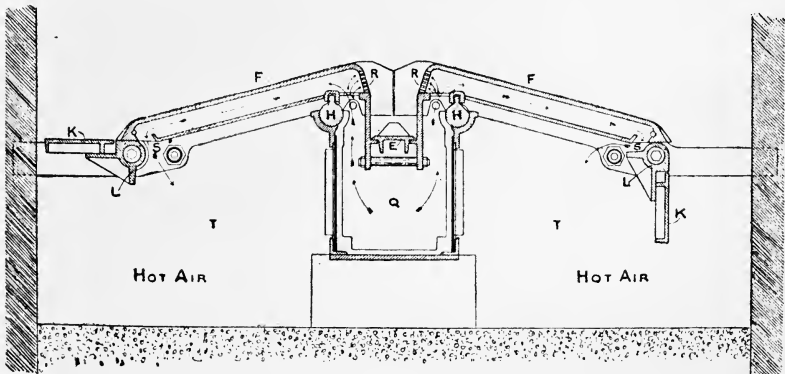

FIG. 38.—Transverse Section of Underfeed Mechanical Stoker. Q is the Magazine for the Fuel; PP are Hot-air Channels; SS are the passages for the Air under the Fire Bars, FF. The Fuel is forced up at RR on to the Bars.

apparatus corresponding to the furnace grate in other forms of furnace, and communicating with the hopper, as shown in Fig. 39. The

furnace bars are different from those usually employed, and one firm of makers of under-feed stokers claims that they have no grate. There is, however, in both forms on the market an apparatus corresponding to a grate type, and the fuel is forced out through spaces between the bars, of which the grate or its equivalent is composed, on to the sides, and the ash is carried off in the usual way. There are two methods employed for forcing the fuel up through the furnace bars. In the "Erith" grateless under-feed stoker a ram is employed, combined with a rod attached to the front of the ram, and carrying wedge-shaped blocks, designed to give a lifting movement to the fuel. The ram is moved forward periodically by the steam

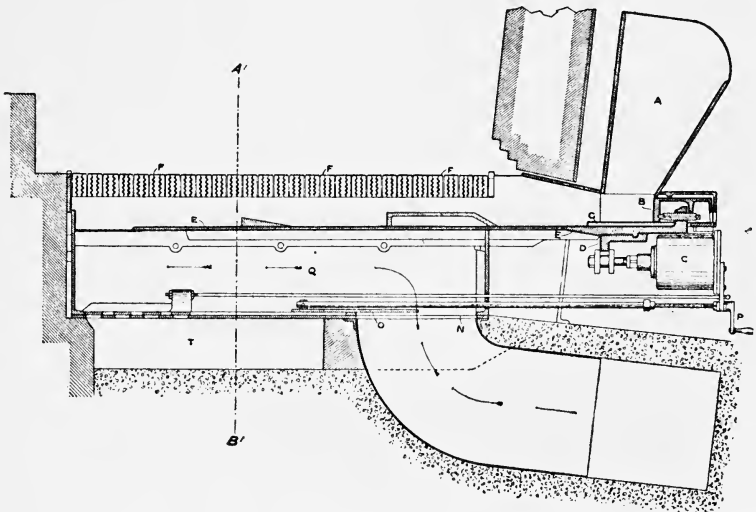

FIG. 39.—Longitudinal Section of Underfeed Stoker, showing the Ram, which forces the Fuel up between the Bars, also the Air Duct and the Hopper. A is the Hopper; F, the Fire Bars; Q, the Fuel Magazine.

piston in the engine cylinders to which it is attached, a certain quantity of fuel being pushed on to the furnace bars, or the dead plates, as the Erith Company prefer to call them, at each stroke. In one form of the Under-Feed Stoker Co.'s apparatus, the fuel is carried forward by an Archimedean screw, the screw being worked by gearing from any convenient source of power, or by a motor or steam cylinder, and in another form by a ram, as shown in Fig. 39. The continuous motion of the Archimedean screw forces the fuel forwards, and at the same time upwards through the furnace bars. In both forms of under-feed stokers, air is admitted to the fuel from underneath, by means of what are virtually tubes, or tuyeres, in the

furnace bars themselves. In the Erith stoker there is an air-chamber underneath the fuel magazine, to which air is brought by fan, or other means, and it is passed from it through the hollows in the dead plates, up into the fuel. In the Under-Feed Stoker Co.'s apparatus, the lower portion of the magazine itself forms an air-chamber, and the air is forced up between the grate bars. It is claimed in both cases that the air consumption and fuel consumption are under complete control, from the front of the boiler, in the usual way.

## Providing the Air for the Furnace

There are four methods of providing the air that is required by the furnace—by chimney draught, by forced draught, by induced draught, and by the aid of steam jets. All of the methods are simply variations of the same thing. In all of them a certain force is applied to the air, to drive it through the fire bars, the fuel lying on them, and the flues, etc., beyond. With forced and induced draught the air is under much greater control. With chimney draught the only method of control is by closing or opening the damper, more or less throttling the supply of air.

## Chimney Draught

Chimney draught is caused by the difference in the weight of the column of hot gases in the chimney, and that of a similar column of air on the outside of the chimney. Perhaps the matter will be more easily understood by reference to the case of the ventilation of a coal mine. At the present time furnace ventilation is not often found in coal mines, but thirty years ago it was very common. Now the furnace has been almost entirely displaced by fans, very much in the same way that chimney draught for boilers is gradually being displaced by one or other of the methods mentioned. In a coal mine there are two vertical shafts, from the surface to the coal seam, a short distance apart, and at the bottom of the shafts there are roads extending into the mine from each of the shafts, the roads being connected by cross-roads, working places, etc., and for ventilation the air has to pass down one of the shafts, called the down-cast, along the road leading from it, through the cross-roads, working faces, to the road leading to the other shaft, known as the up-cast, and through the up cast to the surface again. In the days of furnace ventilation, a large furnace was kept continually burning, near the bottom of the up-cast shaft, the furnace being very similar to that of a boiler furnace, but without boiler flues, etc., and its office was to heat the

return air from the mine, and to provide a column of hot air in the up-cast shaft, the difference between the weight of this column of air and that of the column of air in the down-cast shaft, which was at the temperature of the outside atmosphere, providing what was called the motive column.

Air, it will be remembered, has weight, and when it passes over the surface of the flues, through fire bars, the interstices of coal, etc., it creates friction, and this necessitates the expenditure of a certain force to move it. Further, the weight of a given volume of air varies directly with its absolute temperature. At  $32^{\circ}$  F., 1 lb. of air occupies approximately  $12\frac{1}{2}$  cubic feet; at double the absolute temperature, or about  $525^{\circ}$  F., the same weight of air would occupy 25 cubic feet. The absolute temperature corresponding to  $32^{\circ}$  F., it will be remembered, is  $493^{\circ}$  F., absolute zero being  $461^{\circ}$  F. below the zero of Fahrenheit's scale; consequently double the absolute temperature at  $32^{\circ}$  F. is  $986^{\circ}$  absolute Fahrenheit, corresponding to  $525^{\circ}$  gauge temperature Fahrenheit.

With the arrangements of a boiler furnace, flues, chimney, etc., the property of fluid pressure that has been referred to in a previous portion of this chapter comes into play. It will be remembered that in a fluid any pressure communicated to any part of the fluid is transmitted through the fluid in all directions. In the case of the boiler furnace, the air passes through the ashpit and the fire bars into the coal, and it is the weight of the column of air above the entrance to the ashpit which causes the air to move into and through the furnace. If the hot gases met a similar column of air on the other side of the boiler, the pressure on the two sides would be equal, and there would be no force tending to move the air and the gases through the furnace. But by the provision of a column of hot gases, such as exists in a boiler chimney, and whose weight is less than that of the column of air pressing against the ashpit entrance, there is a force tending to cause the air to pass into the ashpit, and thence through the fire and flues, etc., this force being measured by the difference between the weight of the column of hot gases in the chimney, and that of the equivalent column of air outside the ashpit.

It will be evident from the above, that the larger the area of the chimney, and the greater the height of the chimney, the greater is the force tending to move the air into the furnace, and to move the hot gases through the furnace flues. Further, it is evident that the higher the temperature of the hot gases in the chimney, the greater is the difference between their weight and that of the column of air outside, and therefore the greater is the force moving the air and hot gases or, as it is expressed, creating a draught. On the other hand, it will easily be understood that whatever quantity of heat is left in the hot gases, when they enter the chimney, is wasted, so far as

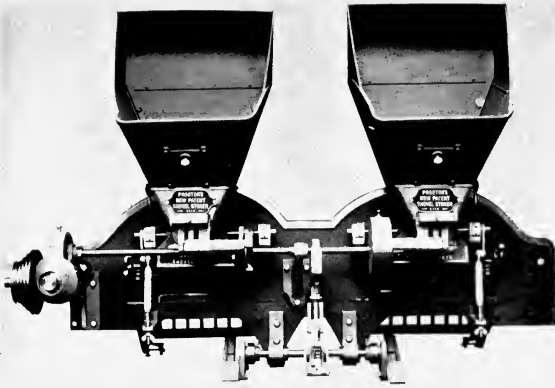

PLATE 8A.—Front View of Proctor's Mechanical Stoker, as fitted to the Two Furnaces of a Lancashire Boiler.

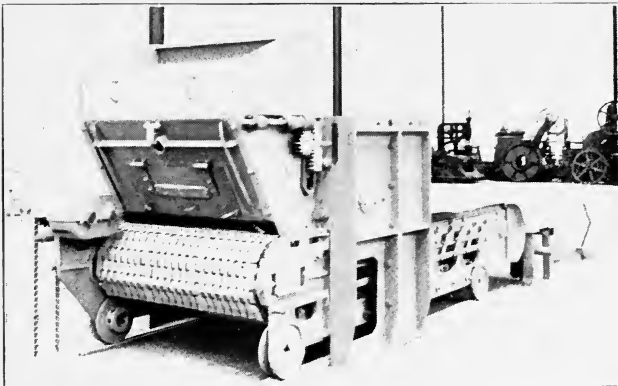

PLATE 8B.—Front View of Babcock & Wilcox Chain Grate Stoker.

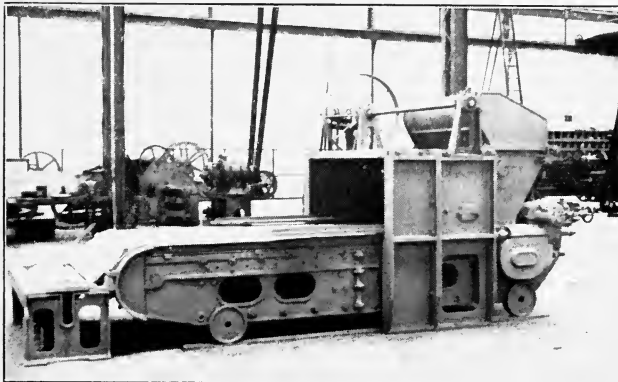

PLATE 8C.—View of Babcock & Wilcox Chain Grate Stoker from the back.  
[To face p. 128.]





heating the water and the steam in the boiler is concerned. The standard temperature at which the hot gases are usually delivered to the chimney is in the neighbourhood of 600°. There is a limiting value to the temperature at which the hot gases are delivered to the chimney, for the following reason. Though the density of the gases decreases in direct proportion to the absolute temperature, the velocity at which they pass through the chimney increases as the square root of the absolute temperature, and the limiting value—the economic temperature—is found to be 550° F. above the temperature of the atmosphere. As the average in this country is in the neighbourhood of 60°, this means that the limiting temperature is in the neighbourhood of 600° F. It is the velocity at which the gases pass up the chimney, which controls the intensity of the draught. The force required to drive the air through the boiler furnace, and to drive the hot gases through the boiler flues and up the chimney, because some force is expended even in overcoming the friction of the hot gases on the walls of the chimney, both in mines and in boiler furnaces, is measured by a special apparatus, known as a water-gauge, the force being described as so many inches of water-gauge. One inch of water-gauge corresponds to 0·578 oz. pressure per square inch, and is arrived at in the following manner. The weight of a cubic foot of water is 62·355 lbs., at 62° F., and consequently that is the pressure exerted by a cubic foot of water upon an area of one square foot. The weight of a mass of water 1 square foot in area and 1 inch in depth is  $\frac{62\cdot355}{12} = 5\cdot197$  lbs., and the weight of a cubic inch of water will be the weight of this last quantity—5·197 lbs. divided by 144 (the number of square inches in a square foot) = 0·578 oz., and this is therefore the pressure which 1 square inch of water exerts upon the square inch base it stands upon, and is the value of the inch water-gauge.

NOTE.—The inch water-gauge must not be confused with the miner's inch, which is something quite different, and has nothing to do with pressures.

The water-gauge usually consists of a **U**-tube, having a scale representing the difference of level between the two legs, reduced to inches of water. The two legs are arranged to be open to the two atmospheres, or the atmosphere and the body of gas, the difference of pressure between which it is desired to measure. There are different methods of accomplishing this, rubber tubes slipped over the ends of the legs of the tube, being a simple and favourite one. One simple arrangement is, the **U**-tube is fixed on a piece of board, or in any convenient position, in one body of gas, say in the atmosphere, and a short tube is led from the end of one leg, through an aperture provided for the purpose, in a partition dividing the two bodies of

gas, into the other body, the second leg being open to the atmosphere where the gauge is fixed.

Evidently the difference between the pressures of the two vessels, or the two air passages, or an air passage and the atmosphere, will be measured by the height of the water in the gauge. It is of course not necessary that the water shall be 1 square inch in section. It may be of any sectional area, provided it is graduated accordingly.

For ordinary boiler work, pressures up to  $2\frac{1}{2}$  inches water-gauge are employed, and of the total pressure required, the fuel takes from 0.2 up to 1.8 inch of water-gauge, according to the substance. The following table, given by Mr. Hutton, shows the draught required for the different kinds of fuel. As will be seen, straw, wood, and the free burning coals require the smallest pressure to drive the air through them, large coal also requires a small pressure compared with small coal, and the anthracites require the largest pressure of all.

TABLE XIV.

Kind of fuel.	Pressure required in inches, water-gauge.
Straw. . . . .	0.2
Wood. . . . .	0.3
Sawdust . . . . .	0.35
Peat (light) . . . . .	0.4
„ (heavy) . . . . .	0.5
Sawdust mixed with small coal . . . . .	0.6
Steam coal (round) . . . . .	0.4 to 0.7
Slack (ordinary). . . . .	0.6 „ 0.9
„ (very small) . . . . .	0.7 „ 1.1
Coal dust . . . . .	0.8 „ 1.1
Semi-anthracite coal . . . . .	0.9 „ 1.2
Mixture of breeze and slack . . . . .	1.0 „ 1.3
Anthracite (round) . . . . .	0.2 „ 1.4
Mixture of breeze and coal dust . . . . .	1.2 „ 1.5
Anthracite slack . . . . .	1.3 „ 1.8

It was mentioned in the first chapter, that a certain quantity of oxygen is required for the complete combustion of every kind of fuel, and it may be mentioned that the minimum quantity of air required to furnish the oxygen for the complete combustion of 1 lb. of carbon, oxidizing to carbonic acid, is approximately 12 lbs. In practice, however, it is never possible to work to exactly these conditions, and it is usual to reckon upon a supply of 24 lbs. of air to each pound of the fuel to be consumed.

The volume of the gases produced from the combustion of carbon, providing that it is completely oxidized to carbonic acid, is the same as that of the air, before the carbon combined with the oxygen, at the same temperature. The volume of the nitrogen, at any given temperature, remains unchanged of course; and the volume of the carbonic acid formed by the combination of the carbon with the

oxygen, is practically the same as that of the oxygen before it entered into combination, always providing the temperatures are the same. Hence the volume of the hot gases is practically the same as the volume of the air supplied to the furnace, and the whole of the gases, consisting of the carbonic acid formed, the unchanged nitrogen and oxygen, have to be raised to the same temperature, the result being that the temperature at which the hot gases leave the burning fuel is never greater than about 2400° F., instead of being in the neighbourhood of 4000° F.

Chimneys are required for two purposes—to furnish the necessary draught, and also to carry off the products of combustion, the hot gases, etc., and to deliver them to the atmosphere at a height where they will do little harm. When the chimney is employed only for delivering the products of combustion harmlessly into the neighbouring atmosphere, it is evident that the height of the chimney may be very much less in a great many instances, than where it is also required to furnish the necessary draught, and one reason why chimney draught is being superseded by the other forms of draught, in places where comparatively low chimneys may be fixed, is because the cost of the chimney itself is often a serious item in the outlay, and because the chimney demands, for furnishing the draught, something like 25 per cent. of the total energy delivered to the hot gases at the furnace. It will be understood that the heat carried by the hot gases is measured by the product of their weight into their temperature, and into their specific heat, and as they set out with a temperature of 2400° F., and are delivered to the chimney at 600° F., 25 per cent. of their energy is used in the chimney; whereas if the chimney was merely an apparatus to deliver the hot gases harmlessly, the only expenditure of energy necessary in the chimney would be that required to overcome the friction of the hot gases on the sides of the chimney. The waste involved in delivering the gases to the chimney at 600° F. may be better appreciated by converting the heat units which they carry into mechanical energy. There is hardly space to reproduce the calculation involved, but remembering that each unit represents 778 foot-lbs. of work, and that each pound of the gas carries off approximately 143 heat units, the enormous amount of energy passing up a chimney will easily be understood. It has been computed that the actual work done by the hot gases, in creating the draught, is only 0.00056 of the amount of energy contained in the gases themselves.

### **Sizes of Chimneys and Horse-Power of Boilers**

The chimney designed to furnish draught for a boiler, or battery of boilers, has two sets of dimensions, both of which are equally

important. Its sectional area must be sufficient to allow the whole of the gases delivered by the boiler, or battery of boilers, to escape freely through the chimney, without throttling. In addition, if the chimney is also to furnish the draught necessary for the boilers, it must be of a sufficient height to furnish the required motive column described on p. 128. The total energy present in the gases passing through the chimney will depend on both of these factors. The larger the area of the chimney, and therefore the larger the volume of the gases passing through it, the greater the energy present in a column of a given height; and also the greater the height of the chimney, the greater the energy present for a given area. The H.P. of the boiler, as it is sometimes expressed, or the battery of boilers, determines the sectional area of the chimney, and this is quite independent of the height of the chimney. The modern method of describing the capacity of the boiler, as able to evaporate a certain quantity of water per hour to steam at a certain pressure, is very much more accurate, and more scientific. For it will be evident that the H.P. furnished by the steam generated in any boiler will vary with the engine in which the steam is used. Thus, taking the consumption of non-condensing engines at from 30 to 40 lbs. of steam per H.P. per hour, simple engines condensing at from 24 to 30 lbs., compound engines at from 18 to 25, and triple expansion engines at from 15 to 20, the H.P. of a boiler, or battery of boilers, could be stated in very different figures, and would be furnishing a very different number of H.P., according to the type of engine to which it was furnishing steam.

From what has been stated on previous pages, it will be understood that, in order that a certain quantity of water shall be raised to a certain temperature, and converted into steam, a certain number of heat units must be delivered to it, and this requires, in each kind of boiler, the consumption of a certain quantity of fuel, again varying with the composition of the fuel, this again requiring a certain quantity of air, and furnishing a certain volume of heated gases. This again implies the presence of a certain grate area in the furnace, or furnaces, in which the fuel is consumed. Hence it will be evident that the area of the chimney will depend upon the area of the grate or grates on which the fuel is burned, to furnish the hot gases that are to pass through the chimney. Professor Thurston gives as a standard for chimneys of 200 feet high and upwards, a sectional area of 2 square inches for each pound of fuel consumed on the grates supplying the chimney; and he gives as a further standard, the sectional area of the chimney as from  $\frac{1}{7}$  to  $\frac{1}{8}$  of the grate area.

It should be mentioned *en passant*, that this last standard will be subject to modification where the chimney is only employed for carrying the gases off harmlessly. As will be explained, with all the

methods known generically as mechanical draught, very much higher rates of consumption of fuel are obtained with a given grate area than are usual with chimney draught, and as this produces a larger quantity of hot gases, if they are not to be throttled by the chimney the sectional area of the latter must be increased in proportion. On the other hand, where the chimney is only employed to get rid of the hot gases, these will be at a much lower temperature than is usual with chimney draught, and therefore their volume will be less from that cause than it would have been where the hot gases create the draught.

### The Factors ruling the Height of a Chimney

It has been explained that the chimney is required to carry a column of hot gases of sufficient size to furnish the necessary motive column. The weight of the column of gases in the chimney, however, will depend inversely upon their absolute temperature. Further, the velocity of the gases have an important bearing upon the matter, as will be seen. The velocity at which the gases pass through the chimney rules the velocity with which they pass through the boiler tubes, or the space around the tubes, flues, etc., and this again rules the rate at which air is admitted to the furnace, and at which combustion takes place. Hence the velocity of the gases in the chimney rules the rate of combustion, this again being ruled by the difference in the pressure between the ashpit and the furnace. Again, the velocity of the gases is ruled by the difference of pressure between the column of the atmosphere, and the column of hot gases in the chimney. The pressure exerted by the motive column is known as the head, and is usually denoted by the letter  $H$ , and the head of any motive column is equivalent to the height through which the gases composing that column would have fallen in acquiring the velocity at which the gases are moving. The velocity at which the gases are moving is found from the formula  $v = \sqrt{2gh}$ , where  $v$  is the velocity of the gases,  $h$  is the height of the motive column, under which they are moving, and  $g$  is the accelerating force of gravity, taken usually as 32.2 feet per second. The formula will be recognized as that which is applied to all falling bodies. It will be seen from it, however, that the velocity of the gases, the accelerating force of gravity being constant, varies as the square root of the head of the motive column. In mining work this is expressed by saying that the velocity of the air varies inversely as the square root of the water-gauge, and this may be applied equally to boiler-work. The height of any column of any fluid required to furnish a given pressure depends directly upon the pressure, and inversely upon the density of the fluid.

Here, in connection with chimney draught, a very important matter comes in, viz. the temperature of the air outside of the chimney. In the accompanying table, which is taken from the Sturtevant Company's book on "Mechanical Draught," the pressures in inches of water-gauge, with different temperatures of the gases in the chimney, and different temperatures of the outside air, are given, the chimney temperatures from 200° to 500° F., and the outside temperatures from 0° to 100°. It will be noted, from an inspection of the table, what a very wide difference of pressure a difference in the temperature of the outside air makes, as, say, between a cold winter atmosphere and a hot summer one. The figures given are for a chimney of 100 feet in height. With the chimney temperature at 500° F., it will be noted that with the temperature of the outside air at 30°, the water-gauge produced is 0.73 inches, while with the same chimney temperature, and with an outside temperature of 100°, the water-gauge is only 0.534, or a reduction of 0.196, sufficient to furnish the pressure for driving the gases through the chimney itself. With a chimney 200 feet high, the above figures would be doubled, and there would be a difference such as would easily occur, say, in Canada, or other countries subject to wide variations of temperature, of 0.392 inches water-gauge.

TABLE XV.

TABLE OF PRESSURES IN INCHES OF WATER-GAUGE, WITH DIFFERENT TEMPERATURES IN CHIMNEY AND OUTSIDE ATMOSPHERE.

Temperature in chimney.	Temperature of external air.										
	0°	10°	20°	30°	40°	50°	60°	70°	80°	90°	100°
200°	0.453	0.419	0.384	0.353	0.321	0.292	0.263	0.234	0.209	0.182	0.157
220°	0.488	0.453	0.419	0.388	0.355	0.326	0.298	0.269	0.244	0.217	0.192
240°	0.520	0.488	0.451	0.421	0.388	0.359	0.330	0.301	0.276	0.250	0.225
260°	0.555	0.528	0.484	0.453	0.420	0.392	0.363	0.334	0.309	0.282	0.257
280°	0.584	0.549	0.515	0.482	0.451	0.422	0.394	0.365	0.340	0.313	0.288
300°	0.611	0.576	0.541	0.511	0.478	0.449	0.420	0.392	0.367	0.340	0.315
320°	0.637	0.603	0.568	0.538	0.505	0.476	0.447	0.419	0.394	0.367	0.342
340°	0.662	0.638	0.598	0.563	0.530	0.501	0.472	0.443	0.419	0.392	0.367
360°	0.687	0.653	0.618	0.588	0.555	0.526	0.497	0.468	0.444	0.417	0.392
380°	0.710	0.676	0.641	0.611	0.578	0.549	0.520	0.492	0.467	0.440	0.415
400°	0.732	0.697	0.662	0.632	0.598	0.570	0.541	0.513	0.488	0.461	0.436
420°	0.753	0.718	0.684	0.653	0.620	0.591	0.563	0.534	0.509	0.482	0.457
440°	0.774	0.739	0.705	0.674	0.641	0.612	0.584	0.555	0.530	0.503	0.478
460°	0.793	0.758	0.724	0.694	0.660	0.632	0.603	0.574	0.549	0.522	0.497
480°	0.810	0.776	0.741	0.710	0.678	0.649	0.620	0.591	0.566	0.540	0.515
500°	0.829	0.791	0.760	0.730	0.697	0.669	0.639	0.610	0.586	0.559	0.534

This is one of the reasons why mechanical draught has made its

way. It will be seen that where the outside atmosphere is subject to changes of temperature of any magnitude, as all atmospheres are, even in temperate climates, and still more so on large continental areas, such as North America, etc., it is necessary to provide a chimney of such dimensions, that the motive column is always present, even in the very hottest weather, and this means that the cost of the chimney is very much greater in consequence, and that there is a very much larger waste of energy in the hot gases passing up the chimney than would otherwise rule.

The height of the chimney is also ruled indirectly by the necessity of providing for a certain definite velocity in the gases. As explained above, a certain velocity in the hot gases is necessary in order that the air from which they are formed may enter the furnace in proper proportion, and this velocity is only obtained by a certain definite motive column or height of chimney. Hence the chimney is obliged to be higher in some cases than would be otherwise necessary, and than would apparently be necessary from an examination of the height and area of the chimney, in order to provide for this velocity. The final solution of the problem is somewhat troublesome, and as usual it has been left to the practical engineer to work out. Mr. William Kent, the author of the "Standard Mechanical Engineers' Pocket Book" in America, has produced the table on p. 136.

The table is based upon a consumption of 5 lbs. of fuel per H.P. per hour. Modern engines work with considerably less than that, as explained above, but the differences in the temperature of the outside atmosphere, and also changes that may take place in the resistance offered to the draught, both within the boiler and in the chimney, have led Mr. Kent to provide very liberally in calculating for the horse-power.

It will be noted that, in the table, the diameters of different chimneys are given, from 18 inches up to 12 feet, these being for circular chimneys, and the equivalent sizes for square chimneys, and, in addition, what is termed the effective area in square feet.

By effective area is meant, the actual space within the chimney, operating to produce the required velocity of the gases. As already explained, the gases, in passing through the chimney, create friction upon the sides of the chimney, and, to meet this friction, the actual area through which the gases pass is taken as so much less than the total area of the chimney itself.

The formula upon which this is calculated is as follows:—

$$E = A - 0.6 \times \sqrt{A}$$

The height of chimneys are given in feet, from 50 feet up to 300 feet, and it will be noted that the chimneys of smaller diameter are given smaller heights, the heights increasing with the sectional areas.

TABLE XVI.  
KENT'S TABLE OF CAPACITY IN HORSE-POWER OF CHIMNEYS FOR STEAM BOILERS.

Diameter in inches.	Side of equivalent square in inches.	Effective area $E = A - 0.6\sqrt{A}$ in square feet.	Height of chimney in feet.																
			50	60	70	80	90	100	110	125	150	175	200	225	250	300			
18	16	0.97	23	25	27	29	—	—	—	—	—	—	—	—	—	—	—	—	—
21	19	0.47	35	38	41	44	—	—	—	—	—	—	—	—	—	—	—	—	—
24	22	2.08	49	54	58	62	66	—	—	—	—	—	—	—	—	—	—	—	—
27	24	2.78	65	72	78	83	88	—	—	—	—	—	—	—	—	—	—	—	—
30	27	3.58	84	92	100	107	113	119	—	—	—	—	—	—	—	—	—	—	—
33	30	4.48	—	115	125	133	141	149	156	—	—	—	—	—	—	—	—	—	—
36	32	5.47	—	141	152	163	173	182	191	204	—	—	—	—	—	—	—	—	—
39	35	6.57	—	—	183	196	208	219	229	245	—	—	—	—	—	—	—	—	—
42	38	7.76	—	—	216	231	245	258	271	289	316	—	—	—	—	—	—	—	—
48	43	10.44	—	—	—	311	330	348	365	389	426	—	—	—	—	—	—	—	—
54	48	13.51	—	—	—	—	427	449	472	503	551	—	—	—	—	—	—	—	—
60	54*	16.98	—	—	—	—	536	565	593	632	692	748	—	—	—	—	—	—	—
66	59	20.83	—	—	—	—	—	694	728	776	849	918	—	—	—	—	—	—	—
72	64	25.08	—	—	—	—	—	835	876	934	1023	1105	1181	1253	—	—	—	—	—
78	70	29.73	—	—	—	—	—	—	1088	1107	1212	1310	1400	1485	1565	—	—	—	—
84	75	34.76	—	—	—	—	—	—	1214	1294	1418	1531	1637	1736	1830	1905	—	—	—
90	80	40.19	—	—	—	—	—	—	—	1496	1639	1770	1893	2008	2116	2234	2354	2473	2594
96	86	46.01	—	—	—	—	—	—	—	1712	1876	2027	2167	2298	2423	2554	2694	2834	2974
102	91	52.23	—	—	—	—	—	—	—	1944	2130	2300	2459	2609	2750	2902	3054	3206	3358
108	96	58.83	—	—	—	—	—	—	—	2090	2399	2592	2771	2939	3098	3258	3418	3578	3738
114	101	65.83	—	—	—	—	—	—	—	—	2685	2900	3100	3288	3466	3657	3855	4053	4251
120	107	73.22	—	—	—	—	—	—	—	—	2986	3225	3448	3657	3855	4053	4251	4449	4647
132	117	89.18	—	—	—	—	—	—	—	—	3637	3929	4200	4455	4696	4937	5178	5419	5660
144	128	106.72	—	—	—	—	—	—	—	—	4352	4701	5026	5351	5676	6001	6326	6651	6976

For pounds of coal burned per hour for any given size of chimney, multiply the figures in the table by 5.



It will be noted also that the possible H.P. of a chimney of a given sectional area increases with the height, a chimney of 18 inches diameter, for instance, when 50 feet high, being equal to the service of 23 H.P.; at 60 feet high of 25 H.P., and so on. The reason for this is, the increased height furnishes the increased motive column, and therefore the increased velocity of the gases, and the increased passage of air through the furnace, and therefore increased combustion.

It should be mentioned that what is called the intensity of the draught, or the pressure available for driving the air and gases through the furnace in the chimney, varies as the square root of the height of the chimney, and this is because the height of the chimney varies with the velocity of the gases.

### Construction of Boiler Chimneys

Boiler chimneys may be constructed of iron or steel, or of brickwork, and in modern plant are often constructed of the two combined, the chimney being built of steel, lined for the whole, or more frequently a portion, of its length with brickwork. For small boilers, such as those of portable engines and small boilers in positions where the smoke is not of consequence, simple iron and steel cylinders, formed from iron plates bent round and riveted together, and riveted to the shell of the boiler where the flue ends, are sufficient. For larger boiler plants, and particularly where the flue gases have to be delivered at a height where they will not be a nuisance, up till recently the common plan was to build brick chimneys, which were sometimes circular in section, sometimes octagonal, and sometimes square. The circular section is undoubtedly the best form, because the whole of the inside of the chimney is employed in carrying the gases; while with the square and octagonal forms the corners often give rise to eddies, which reduce the draught, and would also form pockets for the passage of the soot. The form, however, has also an important bearing upon the question of wind pressure. One of the problems in connection with the building of chimneys is providing sufficient strength for them to withstand the pressure under all conditions, and for this the circular chimney, for the same weight of material, exposes only half the surface to any particular wind that may be blowing; or put it in another way, a chimney that is to be of a given height and a given sectional area may be half the weight if it is circular in section of that required if it is square, and the proportion between the circular and octagonal chimneys is as 4 to 5 for the same conditions.

Another very important point in connection with the building of

chimneys—perhaps *the* most important point—is the foundation. The foundation of the chimney must be of a certain definite depth and width, in proportion to its height and sectional area.

In the building of brick chimneys it is of great importance that the bricks should be of a very high class, and that very much greater care should be taken in laying the bricks than with ordinary building. In fact, chimney building is a special art in itself.

Special forms of bricks have been designed for the building of chimneys, and amongst them may be noted the perforated radial bricks made by the Alphons Custodis Construction Company. The chimney is designed on paper, exactly as a machine is, and the bricks for the chimney are also designed to occupy their proper sectorship of the cylinders they go to make up. It is claimed for chimneys built with these bricks that they stand better, and that better provision is made for expansion, while the chimney itself is more of a solid structure than can be obtained with the ordinary brick. With the ordinary brick, it will be understood, the angles formed by laying the bricks together to form a cylinder must be filled in with mortar; while with radially designed bricks the bricks themselves form the cylinder, the only office of the mortar being to hold the bricks together. It is usual to build an outer protective shell with ordinary bricks, though it is claimed that this is not necessary with the perforated radial bricks. It is sometimes arranged to fix water tanks about halfway up the chimney, the tank taking an annular form, the lower portion being inclined to the vertical, and being supported by special ledges of bricks, a cover being provided for the water above. This arrangement has the advantage of a water tower at a considerable height above the ground, with only a small expense for the support of the tank, where the ordinary water tower would be a somewhat expensive matter.

Steel chimneys are now built very much on the lines of steel boilers, except that, as they have not so much pressure to withstand, it has not been found necessary to take such great care in the formation of the cylinders, the joints, etc. The chimney is built up in sections, each section being made of sheets from 8 to 10 feet in length, the sheets being riveted together in the usual way, the rivet-holes being punched instead of drilled. Steel chimneys are made either to be supported by guys, or to be self-supporting. Where there is a difficulty in obtaining a good foundation, it is necessary to support the chimneys at two or three portions of their height by guys or stays in all directions, the stays consisting of wire ropes, ending in rods attached to anchors in the ground. Where a good foundation is obtainable, the chimney is made self-supporting, by giving it a broad, deep foundation, and by anchoring its base by means of bolts.

## Forced Draught

By forced draught is understood the passage of air under pressure through the boiler furnace, and it may be accomplished in two ways. The stoke-hold may be closed, and the air that is to pass into the furnace may be forced into the stoke-hold under a certain pressure, the ashpits, etc., being left in the ordinary conditions. The stoke-hold may be left under ordinary conditions, and the ashpit may be closed and the air for the fires delivered under pressure to each ashpit. The closed ashpit system is necessarily the most convenient for the great majority of boilers on shore, but on board ship the closed stoke-hold system, or, as it is called in America, the closed fire-room system, has also been adopted, particularly in the case of men-of-war. The objection to the closed stoke-hold system is the fact that the men working in it are exposed to the air pressure, and that it is more difficult to maintain a large space, such as the stoke-hold, closed, than the smaller space formed by the ashpit. One objection to the closed ashpit system is the number of connections that have to be made from the pipe bringing the air to the different furnaces, and the difficulty of delivering the air uniformly to all parts of the furnace. There is a tendency to blow holes in the fuel, and to cause larger heating at certain grate-bars than at others, and to blow out the ashes, etc., into the boiler-room. In the case of the closed stoke-hole system, providing that the air pressure is not high, the arrangement is good, inasmuch as it provides ventilation for the stoke-hold as well as air for the furnaces.

Whichever system is adopted, whether the closed ashpit system or the closed fire-room system, the air pressure is produced by means of a fan placed conveniently to the fire- or boiler-room, and having a duct or other arrangement leading to a supply of fresh air, the fan drawing the air from the fresh supply, and passing it either directly into the stoke-hold or into a pipe leading to the different ashpits.

A modification of the forced-draught system provides for heating the air on its way into the ashpit or boiler-room. It will be obvious that the system is not applicable to the case of the closed stoke-hold, inasmuch as the men would be subject to higher air temperatures than they are at present. The economy of the system is, however, considerable.

It will be understood that with forced draught the fan is required to produce the necessary pressure to drive the air into the furnace, through the fuel and the hot gases which are formed, through the boiler flues, or their equivalent in water-tube boilers, and also to force the hot gases up the chimney. A portion of the necessary pressure will be provided, wherever there is a chimney of any appreciable

height, by the motive column furnished by the difference between the weight of the hot gases in the chimney and the equivalent column outside, and in those cases the fan has really only to provide the pressure that is not furnished by the chimney. On the other hand, with a fan forcing air into the furnace, it is not necessary to provide that the gases ascending the chimney shall have any appreciable temperature at all if the heat which they carry can be economically absorbed before they reach the chimney, and this is one of the advantages of forced draught even where a chimney is already in existence. It will be remembered that it is the common practice to deliver the hot gases to the chimney at about 600° F., because this is about the temperature up to which an increased pressure is obtained, and that with a furnace temperature of 2400° F., this means that 25 per cent. of the heat units are lost. When forced draught is applied, the temperature of the hot gases may be reduced to any figure the engineer pleases, providing that he

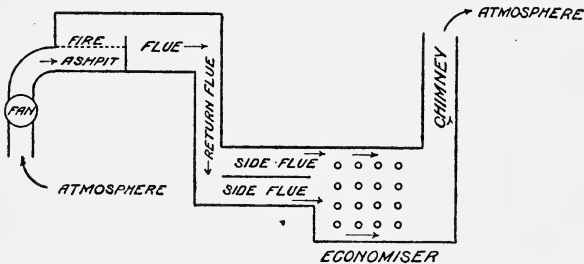

FIG. 40.—Diagram showing the course of the Air and Hot Gases, with Forced Draught and an Economiser.

can get them away comfortably to the outer atmosphere. It is quite common now to take out 300° of temperature from the hot gases by means of economisers, and to deliver them to the chimney at 300° only, this meaning that a further 12½ per cent. of the heat units delivered to the hot gases in the furnace are usefully employed. It appears to the author, subject to practical considerations, that where forced draught is employed this might be carried very much further.

Fig. 40 shows diagrammatically the course of the air and hot gases, in a Lancashire or Cornish boiler, with forced draught, where an economizer is used.

In addition to enabling a larger percentage of the heat delivered to the hot gases to be usefully employed, forced draught enables a higher pressure to be maintained in the boiler furnace, and hence enables a thicker fire to be employed, the fuel lying on the grate-bars in larger quantities, and therefore a larger combustion to be obtained from a given grate area; and further, the quantity of air supplied to

the furnace to be considerably reduced. It was pointed out on p. 130, that the common practice is to supply double the quantity of air to the furnace that is required to furnish the quantity of oxygen necessary to oxidize the whole of the carbon to carbonic acid. This is due to the fact that with chimney draught, which is limited, except where the chimney itself has been built on very liberal lines—and even then sometimes in hot weather—the fuel is usually laid on the furnace bars very thinly, so that the air may easily pass through, and the proper draught be maintained. If a thick fire was maintained, the draught would be checked, and the combustion would be imperfect. With fan draught, as practically any pressure the engineer chooses can be maintained, these conditions disappear. The additional pressure necessary to drive the air through the greater thickness of fuel can easily be provided, and as then a larger mass of incandescent fuel is produced, combustion is very much better, and the quantity of air necessary in order to provide the required quantity of oxygen is reduced to  $1\frac{1}{2}$  times, and in special cases to  $1\frac{1}{3}$  times the theoretical quantity. This means that a further economy is obtained, because the 6 or 9 lbs. of air per pound of fuel that is dispensed with sets free the heat units which they would have absorbed for raising the temperature of the fire itself, and thence increasing the radiation from the surface of the fire, which has a very important effect in the heating of the water in the boiler; and, in addition, the hot gases, starting at a higher temperature, deliver their heat more readily to the metal-heating surfaces with which they come in contact, and thence the heat is more readily transmitted to the water on the other side of the heating surfaces, and the whole efficiency of the boiler is raised.

On the other side of the question have to be placed the charges for driving the fan to produce the necessary quantity of air, and the interest upon the fan and engine (or motor), ducts, etc., but against these may be placed, in the case of new plant, the difference in the cost of the chimney, a smaller chimney being able to do the same work with forced draught as the large one did with chimney draught.

### Induced Draught

By induced draught is meant, sucking or exhausting the air through the furnaces, flues, etc., by means of a fan placed at the back of the boilers, in the path of the hot gases on their way to the chimney, as shown diagrammatically in Fig. 41, with an economizer. In this case the hot gases pass through the fan, and the arrangement of the fan must be such that it will withstand the high temperatures at which the gases are delivered to it, and an arrangement must also be made for getting rid of the deposit of

finely divided carbon, or soot, that is deposited from the hot gases everywhere, as they pass from the boiler to the atmosphere.

One important point must be noted in connection with induced draught, as distinguished from forced or pressure draught, viz. the volume of gases that have to be dealt with. With forced draught it is the air entering the furnace which is at the ordinary temperature of the atmosphere, or if preheated, at whatever temperature it may be heated to, that has to pass through the fan. With induced draught the gases have to pass through the fan at the temperature at which they are delivered to the chimney, and their volume is that due to that temperature, and is proportional to the absolute temperature. At 600° F. their volume would be approximately double that at 60°, the average temperature of air in this country. This means that the power employed for driving the fan will be increased. The power will not be doubled. It will be increased approximately,

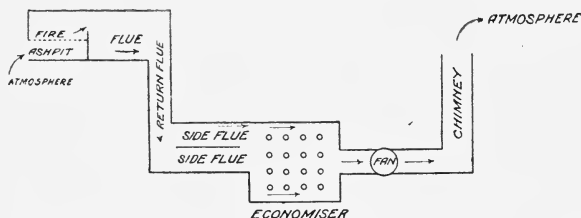

FIG. 41.—Diagram showing the course of Air and Hot Gases in a Lancashire or Cornish Boiler, with induced Draught and an Economiser.

with proper arrangements, about 50 per cent. If the air supplied to the furnace by a pressure fan is raised to 300°, the difference will only be about half that. But, again, if the hot gases are reduced to 300° F., the power for the fan is reduced in proportion.

Another point that must be borne in mind in connection with fans employed for induced draught, is that of the bearings. All parts of the fan will necessarily assume a temperature closely approaching that of the gases that are passing through it, and hence provision must be made for lubricating the bearings of the fan at this temperature. This is not a difficult matter, but it is one of those practical points that must be attended to.

It is claimed for induced draught, that it is a more convenient method of supplying the air than forced draught, because it does not tend to blow holes in the fuel, and the air should be as evenly distributed through the fuel on the furnace grate as with chimney draught. Induced draught is, in fact, the same as chimney draught. Chimney draught is really induced draught, produced by a chimney instead of by a fan.

It is claimed also that the trouble which sometimes arises from the hot gases being blown outwards through the furnace doors, or other openings, into the boiler-room with forced draught, is absent with induced draught. On the other hand, leakage of air, which is common to all forms of draught, is all inwards with induced draught, and with chimney draught; but this merely means that a larger quantity of air is present in the chimney gases, robbing them of a portion of the heat delivered to them, and thereby reducing the efficiency of the boiler as a whole. It will be evident that with increased pressure, the leakage will increase, and in proportion to the increased pressure, and an allowance must be made for this in considering the question of the provision of draught.

Leakage, it will be remembered, takes place between the bricks employed in boiler settings, and this is merely a matter of care in setting, of selection of bricks, and of care in supervision after the brickwork has been set. It is stated that with some boiler settings, there is a quite appreciable passage of leakage air through the joints and the brickwork, into the side flues in the case of Lancashire boilers, and into the furnace and combustion chambers in the case of water-tube boilers.

With induced draught, the fan is usually placed in a separate passage, leading from the end of the boiler flue, or the economizer chamber to the chimney, the ordinary passage being closed by a damper when the fan is working, and allowed to remain open if anything happens to the fan, and the chimney draught has to be relied on.

## **Induced Draught Combined with Heating of the Air for the Furnace**

It has been mentioned on p. 39, in connection with forced draught, that the air is sometimes heated before it enters the furnace. This plan is also adopted in connection with induced draught. In particular, Messrs. John Brown & Co., of Sheffield, have worked out the Ellis and Eaves system of induced draught with air heating, principally for use on board ship, but they have also adapted it to land boilers. The arrangement for use on board ship is shown in section in Figs. 42 and 43, one of which is a cross section, and the other a longitudinal section, through a marine boiler of the ordinary multitubular type. The air heating arrangement is fixed in the front of the boiler, where, it will be remembered, the uptake for the hot gases leading to the funnel is fixed. The air-heating arrangement consists of a number of tubes fixed vertically, as shown, in the uptake, so that the hot gases passing to the funnel are obliged to pass through them, and

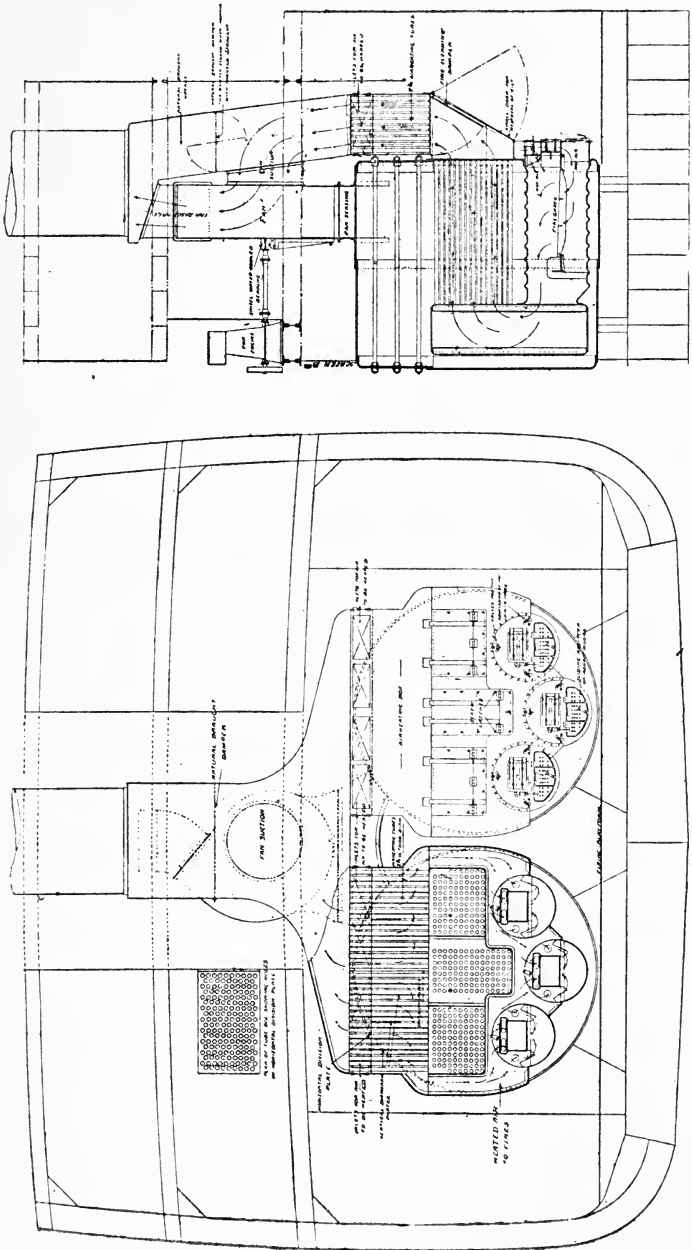

Figs. 42 and 43.—Transverse and Longitudinal Section of Ellis and Eaves system of Air-heating for Marine Boilers, with induced draught. The Air-heating Tubes are shown above the Boiler Tubes, and in front of the Boiler.



the air to be heated passes around the tubes, and is then conducted to the stoke-hold. The course of the air and of the flue gases, is shown by the arrows in the longitudinal section. The fan is fixed above the boiler, and is driven by its own engine fixed behind, with a long shaft, the bearings of the fan being water cooled. For land boilers a somewhat similar arrangement is made. The apparatus has also been fixed to Babcock and Wilcox boilers. As in the marine boiler, a number of tubes are placed vertically above the boiler, and in the path of the hot gases on their way to the chimney, and the air to be heated passes over the outside of the tubes, and is conducted thence by means of pipes provided for the purpose, to the ashpit. As will be recognized, this arrangement is an adaptation to air heating of the principle that is employed for heating feed water by means of the hot gases and exhaust steam. It will be understood, of course, that the chimney will not produce as great an intensity of draught, that is to say, as high a water-gauge, when any air or water heating apparatus is interposed between the boiler and the chimney, or when any further quantity of heat is taken out of the gases, above that taken out in the boiler itself; but, as already explained, where there is a fan draught, this does not matter, and the loss of water-gauge is more than compensated for by the economy in coal produced by heating the air. In the Ellis and Eaves system, the air is heated to about 300° F., and it is claimed that the air heating and fan combined, produce an economy of from 10 to 15 per cent. in the coal consumed in the furnace. That is to say, the coal saved by heating the air, less the coal required to be burned to make the steam for driving the fan engine, amounts to from 10 to 15 per cent. of the coal consumed with chimney draught.

## Forms of Fans Employed for Mechanical Draught

There are two kinds of fans made, known as the propeller and the centrifugal fan. Only the centrifugal fan is of any use for furnishing draught to boilers. The propeller fan is merely a screw, similar in construction, though smaller, to the screw of a steam ship, and it screws the air from one side of it to the other, just as the water is screwed from one side of the propeller to the other; so that, if a fan of the kind is placed in a partition, such as the outer wall of a room, when revolved, it will cause a passage of the air either from outside into the room, or from the room to the outside, according to the direction in which it is turned.

Its blades, or areas, are really sections of a screw. This form of fan can only be employed where the pressure required is *very* small

indeed. It is used for ventilating buildings, but even there only where the system of ducts is so arranged that the total resistance offered to the passage of the air requires the expenditure of only a small fraction of an inch water-gauge to overcome it. At the Birmingham General Hospital, for instance, where 2,000,000 cubic feet of air pass through the building per minute, the pressure is only  $\frac{1}{20}$  inch water-gauge, and a number of large fans of the propeller type are able to deal with it.

In the centrifugal fan the air is carried outwards from the centre to the periphery of the fan by centrifugal action. Centrifugal fans vary very much in construction, but all are on certain main lines. In all of them there is a central circular aperture, forming the inlet for the air, and a number of blades, usually held between two discs, and a number of openings at the circumference. As the fan is revolved, the air lying between the blades is propelled outwards by centrifugal force, and this creates a difference of pressure between the inlet aperture and each of the outlets. The air from the outside atmosphere, or the atmosphere to which the inlet is connected, rushes into the space where the lowered pressure rules, the result being a continual passage of air through the fan. The outlets to the fan are arranged to pass in front of a chimney, or duct of some kind, at a certain period of the revolution, and to discharge their air into it. In some forms of fan the chimney or duct is given what is called an *evasé* form, the object being to reduce the velocity of the air as it leaves the fan.

Strictly speaking, the fans for forced draught, and for induced draught, should be differently constructed, but in practice any fan may be employed for either, providing that it will furnish the necessary pressure, and accommodate the gases, or air, that has to pass through it. For forced draught the inlet is open to the outside atmosphere, the outlet or duct being connected either to the stokehold, or to the duct leading to the ashpits. For induced draught the inlet is connected to a duct leading to the boiler flues, and the outlet to a duct leading to the chimney.

### Sizes of Fan required

As with chimneys, so with fans, there are two requirements. The fan must be wide enough, in a direction measured at right angles to the radius, to accommodate the whole of the air or gases without throttling them. It must also furnish a sufficient pressure to overcome the resistance of the furnace, boiler flues, and chimney.

The volume of air or gases any fan will accommodate, depends directly on its width. The pressure the fan will create depends

directly upon the square of the speed at which its blade tips are travelling, and the power absorbed in moving the air depends directly upon the cube of the speed of the fan. The power required to move a given quantity of air, is given by the formula  $W = p \times a \times v$ , where  $W$  is the work performed in moving the air,  $p$  is the pressure under which it is moved,  $a$  is the area in square feet over which it is moved, and  $v$  is the velocity of the air in feet per second. The formula may be reduced to the following:—

$$W = \frac{d a v^3}{2g}$$

in which  $W$ , as before, is the work performed in moving the air or gases,  $d$  is the density compared with air at standard pressure,  $a$  is the area in square feet over which it is moved, and  $v$  is the velocity.

From this it will be seen that the power varies as the cube of the velocity, and as the velocity of the air depends directly upon the velocity of the fan, the power required depends directly upon the cube of the speed of the fan.

The power required to move any given quantity of air, with any given water, is given by the formula.

The power required to be delivered to the fan shaft, in order to provide the given velocity of air with the given pressure, is found by equating the power found from the last formula, with the efficiency of the fan. The efficiency of the fan may be taken as 40 to 50 per cent.

## Draught by means of Steam Jets

This method is really a form of induced draught, and it operates on the same principle as the injector. It has various forms, but in all of them a tube is inserted in the side of the boiler, under the grate bars, and a steam pipe, ending in a nozzle, is fixed centrally in this tube, the steam passing from it under and up through the fire bars, and by creating a difference of pressure between the inner end of the tube and the outer atmosphere, drawing the air after it, the air passing up between the fire bars, through the fuel and so on. Fig. 44 shows the form of Messrs. Meldrum's furnace in which draught is induced by steam jets, and also the form of the jet and air inlet. It is arranged that the steam jet, which is taken from the boiler, is superheated, by passing through a pipe above the furnace before entering the nozzle. It is claimed that the steam jet keeps the furnace bars cool by condensing on them and being re-evaporated afterwards.

There is the usual controversy between advocates of steam-jet

draught, and fan draught; but, as usual, all of the forms are applicable to certain cases. The steam-jet method has the advantage of lower

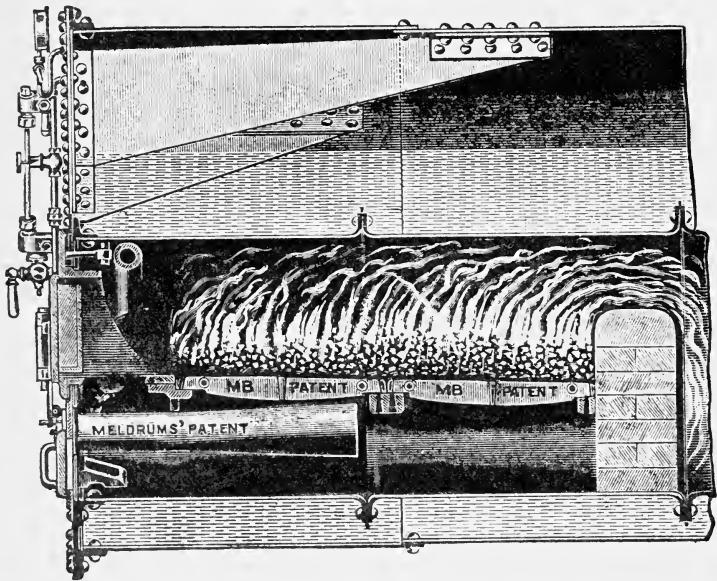

FIG. 44.—Longitudinal Section of a Lancashire Boiler, fitted with Meldrum's Fire Bars and their Steam Jet. The Steam Jet is fixed inside the Trumpet shown in the Ash-pit, the Steam being taken from the Boiler and superheated by being passed through the Tube shown, in the front of the Furnace.

first cost, and the absence of moving parts. It is also easily applied to existing boilers.

Messrs. Grainger make an adjustable nozzle for steam-jet draught.

## Boiler Dampers

Dampers are fitted to all boiler flues, to enable a certain control to be obtained over the draught. Even where forced, or induced draught is employed, dampers are always fixed. They are virtually gas valves, controlling the passage of the hot gases, and thence the air entering the boiler furnaces, and consist of doors arranged to completely fill up the flues in which they are placed. Their position is controlled by a system of levers and chains from the front of the boiler, operated by the stoker. Closing the dampers prevents all passage of the hot gases, and nearly prevents the admission of air to the furnace. If there were no air leakage it would do so. Partially

closing the damper throttles the supply of air, just as partially closing a steam valve throttles the passage of steam.

## Automatic Damper Regulators

The dampers are sometimes controlled automatically by the pressure of the steam, the damper being partially closed when the steam pressure rises, and opened when it falls. One apparatus designed for this is the Patterson hydraulic damper regulator, made at Baltimore in America. The apparatus is designed to work the damper by a hydraulic motor, which moves a chain up and down, the chain passing over pulleys which move the damper up and down. The hydraulic motor is operated by a balance controlled by a small steam cylinder, to which the pressure of the boiler is admitted, a steelyard enabling the time at which the apparatus comes into operation to be varied at will. As the steam pressure rises or falls, the admission of the water under pressure to the hydraulic cylinder is controlled, and the damper is moved up and down.

## The Lagonda Damper Regulator

This is another apparatus intended to automatically control the motion of the damper in accordance with variations of the steam pressure. It consists of a steelyard, on which a balance weight is suspended, the position of which can be varied, according to the will of the engineer, the steelyard being moved up, against the pull of the balance weight, by the pressure of water upon a diaphragm enclosed in a cylindrical space. The entrance of water into the cylinder containing the diaphragm is controlled by a second lever, with a balance weight, opposing a second cylinder with a diaphragm. The pipe leading to the first diaphragm and the cylinder containing the second diaphragm are full of water under ordinary conditions, and the pressure of the water maintains the damper in the position in which the engineer wishes it to remain. If the steam pressure rises, the pressure inside the first diaphragm is increased, and the lever to which it is attached, moves in the direction for closing the damper. On the other hand, if the steam pressure falls, the lowered pressure is made to allow a portion of the water to run out, to lower the pressure under the diaphragm controlling the damper lever, this causing motion in the direction for opening the damper. There is a valve in connection with the second diaphragm, which controls the admission of water and steam in accordance with the requirements of the service.

Messrs. Fraser & Chalmers also make an automatic damper regulator, the details of which are shown in Fig. 45. They are very

(Locke's Patent.)

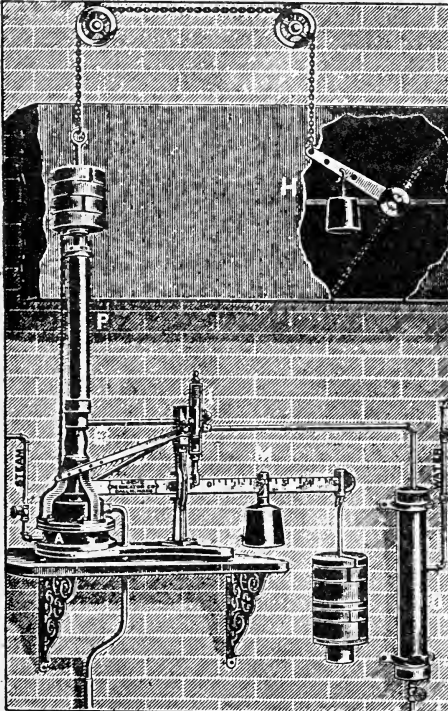

FIG. 45.—Automatic Hydraulic Damper Regulator, made by Messrs. Fraser and Chalmers. The Hydraulic Cylinder is shown on the right. Regulation is effected by it, in connection with the Steel Yard shown in the centre and the Steam Cylinder on the left.

similar to those described above, the hydraulic cylinder on the right controlling the apparatus. Water at a pressure of 20 lbs. per square inch is required.

## Boiler Cleaners

The deposit of foreign matter and the formation of scale upon the water surface of boilers, has been referred to, and the different devices explained for preventing a deposit. In spite of all that has been done in that direction, sometimes owing to imperfect attendance, and from other causes, it is found that scale is still formed, and in the case of the tubes of water-tube boilers, the matter may become very serious, as the bore of the tubes is considerably reduced, and in addition, as explained so frequently, the resistance offered to the passage of heat from the hot gases to the water is considerably increased. To meet this,

several apparatus have been designed for the purpose of removing the scale.

The Weinland mechanical boiler-tube cleaner, designed specially for water-tube boilers, has a head shaped very much like a screw point, which is intended to bore its way into the scale, and behind the head are a number of conical steel cutters, gradually increasing in size, and increasing the bore, as the machine moves forward. Behind the conical cutters are two sets of cylindrical cutters, carried on pins, and revolving freely. The action of the apparatus is very

much like that of a milling machine, after the screw head has bored its way in, the cutters being practically milling tools, arranged to cut the scale instead of metal. The apparatus is held at the end of a rod, long enough to allow it to go right through the boiler tube to be cleaned, and is revolved by a strap, from any convenient source of power, or by an electric motor. For curved tubes, such as those of the Stirling and other boilers, a special arrangement is made, enabling the cleaner to go round the curves. The apparatus is employed for cleaning out filter tubes, economizer tubes, feed-water heater tubes, and in fact anywhere that deposit may form.

### **Turbine Boiler-Tube Cleaners**

The self-acting turbine driven pipe cleaner is an apparatus well known to water-works engineers, and very much employed by them for cleaning off the scale that forms on the inside of water pipes. It consists of a small turbine, of sufficient size to drive the cleaning apparatus, carried on an axle, to which are also attached usually three or more cutting tools, revolving on their own axes. In cleaning the tubes of water works, the force of the water current is made to drive the apparatus by the aid of the turbine, and the same arrangement is made use of for driving turbine boiler-tube cleaners, water being supplied from any convenient source for the purpose. The Weinland turbine boiler-tube cleaner, made by the Lagonda Manufacturing Company, is on these lines.

A steam jet is a very favourite device for cleaning the tubes of water-tube boilers, the steam being delivered at the entrance of each tube into its header by means of a flexible metallic tube and a nozzle. The pressure of steam breaks up the deposit, and the injector action assists.

### **Boiler Fittings**

The fittings required for a boiler consist of a stop valve, a safety valve, feed pipe, and check valve, scum pipe and cock, and, in addition, gauge cocks and steam- and water-gauges. Gauge cocks are not so often now fitted as in the earlier days of steam. Where they are used there are three—one in the water space, one in the steam space, and one on the level where water and steam should come together. When the lower one is turned on, water issues; when the upper one is opened, steam issues; and when the middle one, water and steam. Gauge cocks are only intended to be used when the proper gauges are not working. The proper water-gauge has two cocks, one fixed in the water space and the other in the

steam space, with a substantial glass tube connecting them, the tube being protected by brass fittings, in modern practice. When the two cocks are open, the position of the water in the gauge corresponds with that in the boiler. The water-gauge is drained by a small pipe.

In addition, a steam-gauge is always fixed on the front of the boiler. It consists of a shallow cylindrical case, with a glass front, and a dial behind the glass, over which a needle pointer sweeps. The pointer is pivoted at its centre in the usual way, and is moved by a toothed wheel, gearing into a rack, forming a sector of a circle, and attached to the end of a small metal tube, the other end of which is connected by a pipe to the steam space, whose pressure is to be gauged. The motion of the pointer is resisted by a spiral spring, coiled round the pivot upon which the pointer moves. The

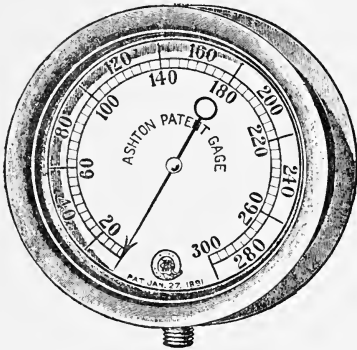

FIG. 46.—A complete Steam Gauge, with Dial and Needle.

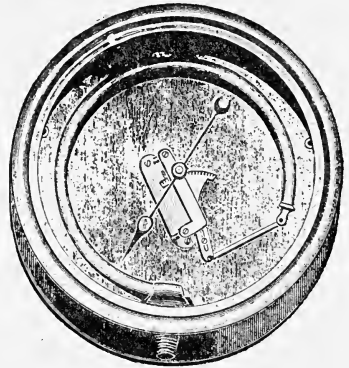

FIG. 47.—The Steam Gauge shown in Fig. 46, with Dial removed, showing the Tube upon which the Steam acts and the Gearing giving motion to the Pointer.

heat delivered to the pipe by the steam causes it to expand, and its free end turns the pointer round, in opposition to the spring mentioned, the dial being graduated in accordance. It is usual in steam boilers to mark the positions on the dial of safe-working steam pressure. Figs. 46 and 47 show one form of steam-gauge, and Fig. 48 shows a Lancashire boiler with all fittings.

## Safety Valves

The safety valve has become almost a proverb. It is an absolute necessity in the case of all steam work, and by Board of Trade regulations is obliged to be fixed upon all boilers. The object of the



safety valve is to relieve the boiler, should the pressure within it rise above a certain figure. All boilers, as explained, are constructed of materials that are calculated to resist strains from within, of several times the maximum they should meet with under ordinary conditions. But there are cases, by no means so common now as in days gone by, where steam accumulates, it not being used by the engines, and the fires remaining burning, the pressure of the steam continuing to increase, in which, unless some relief were made, the boiler would burst, and steam and boiling water would be forced out into the boiler-room, scalding, and probably killing, those present. As it is, even, when boilers are allowed to become weak, their shells being eaten away gradually in places, and nothing being known of the fact, the pressure of steam the boiler is allowed to furnish not being decreased, a day comes when a little increase of pressure breaks through one of the weak spots, and disaster is the result.

No safety valve can possibly provide for carelessness of the kind last

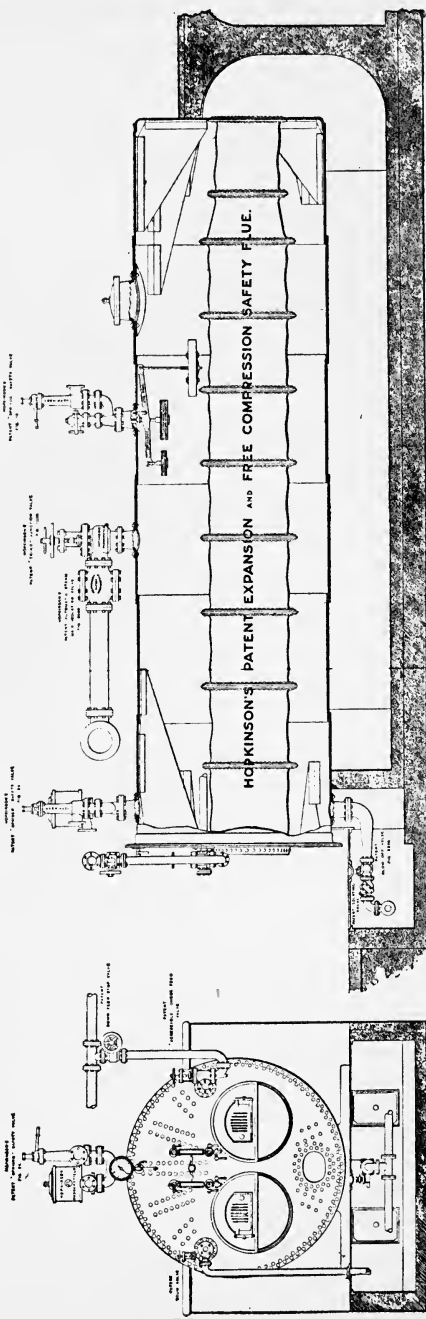

Fig. 48.—Transverse and Longitudinal Section of a Lancashire Boiler, with Hopkinson's Flue, and complete Boiler Fittings. The Drawings also show the Bottom and Side Flues.

mentioned, but it can and does provide for accidental accumulation of steam, and therefore the increase of pressure beyond a safe limit. Safety valves are arranged to open, and to allow the steam to escape, if the pressure rises above a certain fixed point, for which the valve is set.

There are three forms of safety valves on the market, that may be described as lever valves, spring valves, and dead-weight valves.

The earliest form of the safety valve was the lever valve. The valve itself may be of any one of the well-known types of valves, the moving portion of which is controlled by a vertical rod, attached to a lever

of the second order, the lever having a movable weight upon its arm. The position of the weight rules the pressure of steam at which the valve will open, and the weight itself is proportional to the difference between the arms of the lever. Thus, if the safety valve has an area of 2 square inches, and the rod controlling its motion is 2 inches from the fulcrum, while the weight is 12 inches from the fulcrum, if the valve is required to open with, say, a pressure of 80 lbs. per square inch, the weight must equal  $\frac{80 \times 2}{9} = 23.3$  lbs.,

say 24 lbs., and the pressure at which the valve opens can be increased or decreased by sliding the weight along the rod.

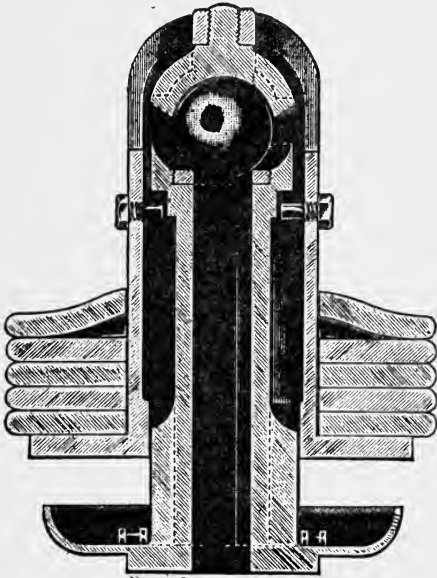

FIG. 49.—Section of Eaves' Dead-weight Safety Valve.

In spring valves, a spiral spring takes the place of the lever and weight described in the last form. The tension of the spring can be regulated by a nut above it in the usual way, and the pressure of steam at which the valve opens is regulated by the position of the nut.

In the dead-weight valve, which is gradually coming into general use, the vertical member controlling the opening of the valve has a horizontal collar over which are slipped rings, forming the weight required. Steam passes up through the central opening, and when the pressure exceeds that for which the valve is set, it lifts the whole thing bodily.

In Eaves' dead-weight safety valve, which is made by Messrs. John Brown and Co., and which is shown in Fig. 49, the action is twofold. The valve itself, it will be seen, is a spherical ball, and when the pressure in the boiler exceeds that for which the valve is weighted, the outside portion lifts, and allows the steam to escape by the side passages. If the steam does not immediately go down, a further action takes place, the central portion lifting, and allowing a further escape of steam.

### Atmospheric Relief Valve

The atmospheric relief valve is not much heard of now, but it was of considerable importance in the early days of steam work. If a boiler was allowed to become cold, its furnaces to go out, and its steam to condense, it happened in the early days of steam that at times the pressure of the atmosphere was greater than the pressure inside the boiler, the result being that portions of the boiler were forced inwards. To meet this the early boilers were fitted with atmospheric valves, which opened inwards, in the same manner as the safety valve opens outwards, admitting air, and equalizing the pressure within and without the boiler. The increased pressures employed, and the consequently increased tensile strength of the materials of which boilers are composed has rendered the atmospheric valve unnecessary.

### High and Low Water Safety Apparatus

In addition to the ordinary safety valve, relieving the pressure on the boiler when it exceeds a certain figure, the modern boiler is further protected by apparatus designed, in some cases, to sound an alarm whistle if the level of the water is too high or too low in the boiler, and in other cases to open a safety valve, sometimes arranged specially for the purpose, and sometimes forming the ordinary safety valve of the boiler. The arrangement is shown in Fig. 50, from which it will be seen that there are two floats, suspended from opposite arms of a lever—one the low-water float, and the other the high-water float. The high-water float is always out of the water, except when it rises above a certain depth. The low-water float is always in the water, and its weight is always taken by the water, except when the water falls to a certain depth. In that case the low-water float commences to bring weight upon its end of the lever, and if the water continues to fall, it either blows the whistle, or opens the valve, allowing steam to escape. It will be understood that there

is great danger in allowing a boiler to run dry, while it is still making steam.

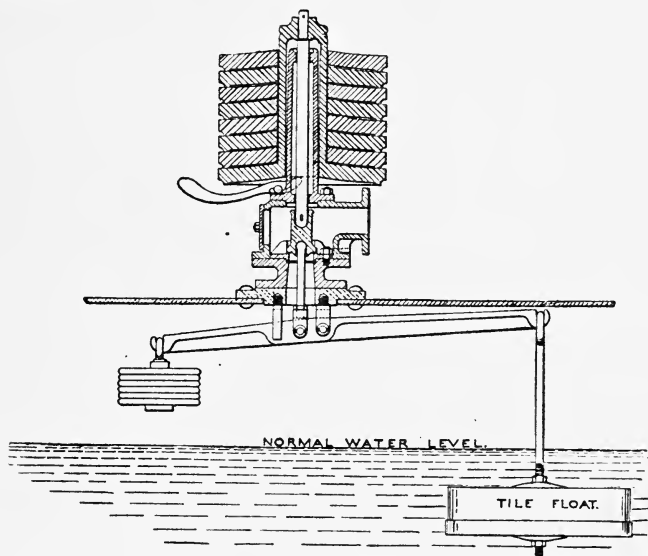

FIG. 50.—Section of High-steam Pressure, and Low-Water Safety Valve fitted to a Lancashire Boiler, as made by Messrs. Alley and McLellan.

## Combined Stop and Safety Valve

For economy it is sometimes arranged to combine the safety valve and the stop valve in one. It is opened by hand in the usual way, and opens with an excess pressure of steam.

Stop valves are described on p. 254. The stop valves used for disconnecting a boiler from service is of the same form, etc., as that used for connecting and disconnecting an engine.

## Heating the Feed Water for the Boilers

It has been pointed out in the previous chapter that it is advantageous to heat the feed water entering the boiler to as nearly the temperature of the water from which steam is being produced as possible, because of the effect upon the circulation. It has also been pointed out that there is a considerable waste in the hot gases when delivered to the chimney at  $600^{\circ}$  F., and that while  $600^{\circ}$  F., or thereabouts, is the limit at which increased draught is obtained, there is

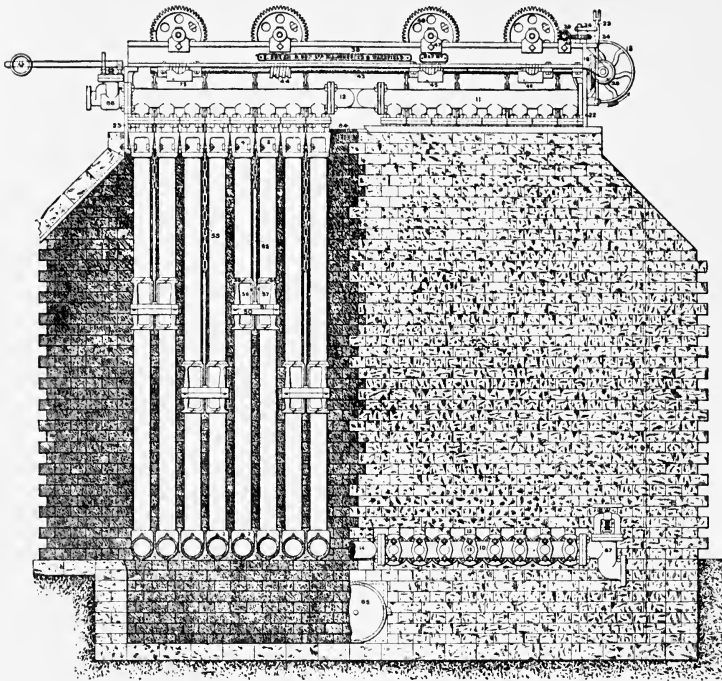

FIG. 51.—Elevation of Green's Economizer, with part of the Brickwork removed, to show the Tubes.

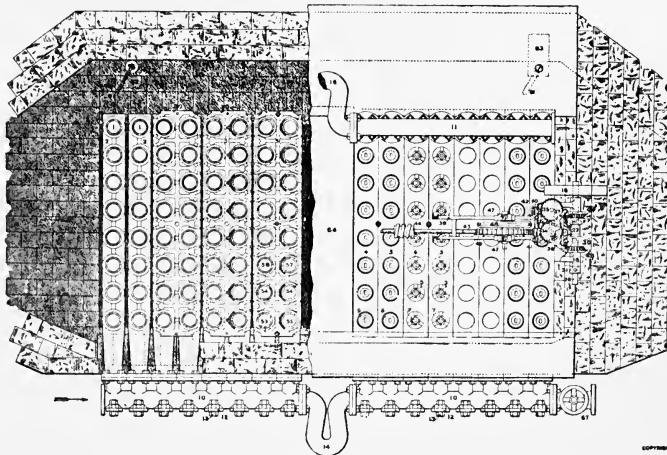

FIG. 52.—Sectional Plan of Green's Economizer.

very little difference between the draught obtained at 300° F., and that at 600° F. In connection with this, however, the fact of the variation in the temperature of the outside air, and its effect upon the intensity of the draught, with any given temperature of fuel gases in the chimney, must not be lost sight of, and therefore it is not wise, if chimney draught is depended upon, to reduce the temperature of

the chimney gases below 400° F. This, however, leaves 200° F. under ordinary working conditions, that may be usefully employed, and in a great many cases where furnace gases arrive at the chimney at a much higher temperature than 600° F., it leaves a very much wider margin.

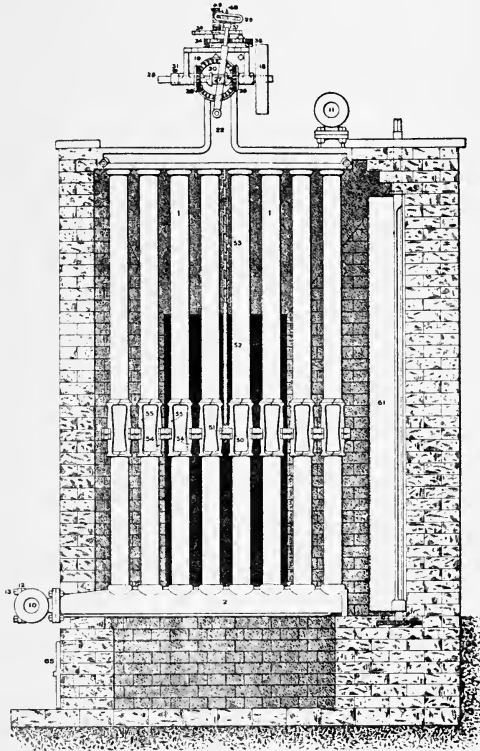

FIG. 53.—Transverse Section of Green's Economizer, showing the Tubes and enclosing Brick-work.

## Economizers

This margin of temperature is made use of to heat the feed water in an apparatus known as an economizer, on its way to the boiler, the usual arrangement, of which there are several variations, being as follows. There are a number of iron tubes fixed vertically, as shown in Figs. 51, 52, and 53, in a brick chamber built for them at the back of the boilers, the chamber being so arranged that

the flue gases can be obliged to pass through it, or can be allowed to pass by a flue avoiding the economizer, or bye-pass, directly to the chimney, as shown in Fig. 54. The water to be heated is made to circulate through the vertical pipes, and the hot gases are made to pass over the outside of the pipes, delivering their heat to them. Two difficulties arise in connection with this arrangement: the hot gases, as they are cooled by delivering up their heat to the economizer tubes, deposit

the finely divided carbon known as soot, and which is usually deposited as a lining to the chimney, upon the outside surface of the tubes. Carbon in the finely divided state is a very poor conductor of heat, for the reason that has been explained in an earlier portion of the book, that there are a number of small air spaces between the particles of carbon, which offer a very high resistance to the passage of heat currents. Hence, unless the deposit of soot is periodically removed from the pipes, the efficiency of the economizer and the heat delivered to the feed water would very speedily be reduced. To accomplish this, all economizers have scrapers provided on the

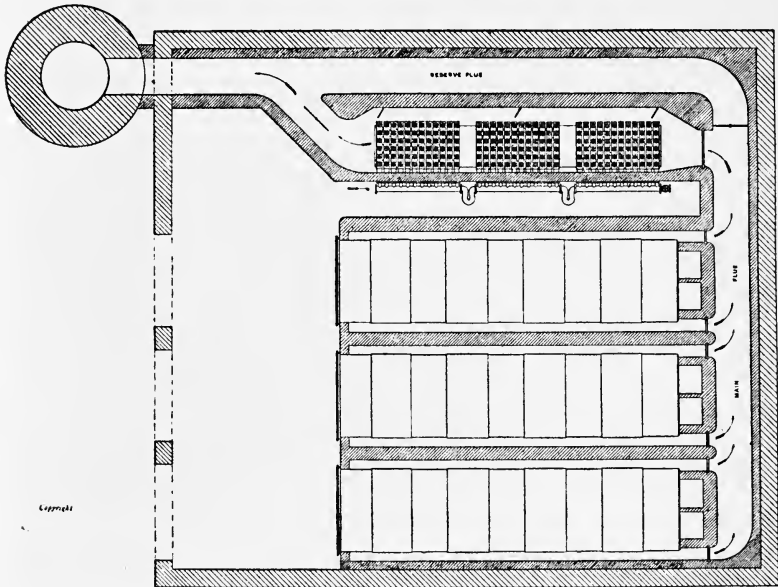

FIG. 54.—Plan of three Lancashire Boilers, with Green's Economizers, in three groups of Tubes, together with the Chimney and the Bye-pass, or Reserve Flue.

outside of the tubes, one form of which is shown in Fig. 55, and the scrapers are kept continually moving up and down the surface of the tubes, constantly removing the deposit of soot, and ensuring that the hot gases have free access to the metal surface, the soot falling to the bottom of the economizer pit, or, in some forms of economizer, into a box provided for it, and being removed periodically. The scrapers for the whole of the tubes in an economizer are worked by chains or rods actuated by gearing fixed above the tubes, as shown in Fig. 51, the gearing being driven by a small engine fixed for the purpose, or by an electric motor, the latter being a favourite plan in

electricity generating works, or wherever there is an electricity supply on the ground. The other trouble is the deposit of the salts, that are carried in the feed water, on the inside of the tubes. This is provided for usually by removing the salts, by means of water softeners, or other methods, before the water enters the economizer. If the salts are not removed, a crust will be formed on the inside of the tubes, similar to that which is formed on the water surface of boilers, that must be removed from time to time, by special appliances.

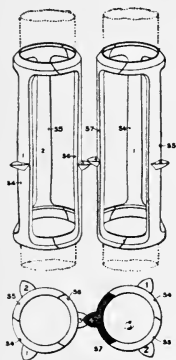

FIG. 55. — Elevation and Plan of the Scrapers employed by Messrs. Green on their Economizers. The Scrapers fit closely on the outside of the Tubes, and are kept continually moving up and down, scraping off the Soot.

**Green's Economizer.**—In Green's economizer, which is the best known, and which is shown in Figs. 51 to 54, the tubes are all made to one standard, 9 feet in length, and  $4\frac{9}{16}$  inches internal diameter. The tubes are built into sections, and the sections built into batteries, according to the quantity of water that the economizer is to deal with, sixteen tubes being the unit. The capacity of each tube is  $6\frac{1}{4}$  gallons, and it is recommended by Messrs. Green that the whole of the tubes should be emptied every hour; or, to put it in another way, that the velocity of the water through the tubes should be at the rate of  $6\frac{1}{4}$  gallons per hour, or about  $\frac{1}{10}$  of a gallon per minute. This rule enables the size of the economizer required to deal with the water evaporated by any boiler, or battery of boilers, to be easily estimated, by the following formula:—

$$N = W \times 6\frac{1}{4}$$

where  $N$  is the number of tubes required, and  $W$  is the number of gallons of water per hour evaporated by the boiler, or battery of boilers.

In Messrs. Carter's economizers, the tubes are made in a special form. Two tubes of a special section are cast in one, with a connecting passage at the bottom, and an opening at the top, for connection to the box.

In the Green's economizer, the tubes forming a section are forced by hydraulic pressure into the top and bottom "boxes," which are tubular castings, having connecting pieces, for the entrance of the tubes.

In all forms of economizers, the rule which applies to all cases of this kind, where it can be adhered to, is adopted, viz. the flue gases and the water to be heated pass through the apparatus in opposite directions, the hottest water meeting the hottest gases, and the coldest water meeting the coldest gases. The water enters the



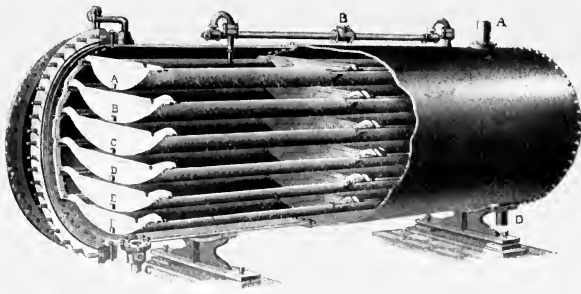

PLATE 9A.—Internal View of Hoppes Feed-water Heater and Purifier. The Water passes down over the Trays shown, in succession, depositing Foreign Matter in them.

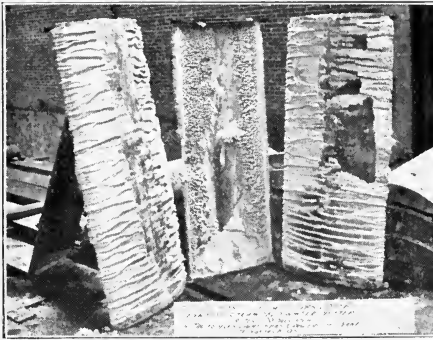

PLATE 9B.—Deposit taken from a Hoppes 3000 H.P. Feed-water Heater, after thirty days' run.

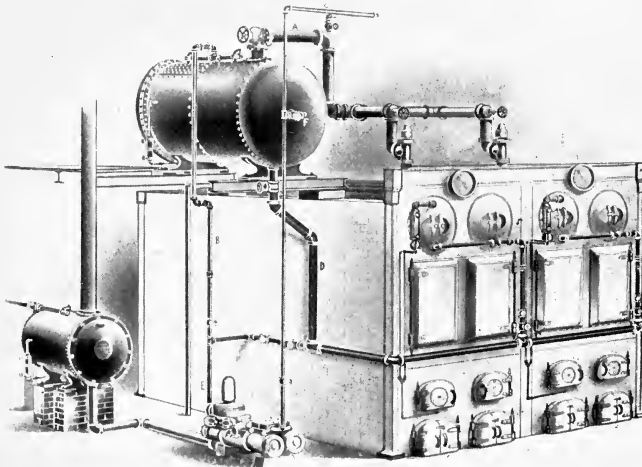

PLATE 9C.—Water Tube Boiler, fitted with Hoppes Feed-water Heater. The Feed-water Heater is shown above the Boiler, the Water from it entering the Boiler below water level. The Tank shown below keeps the Heater supplied with Water. [To face p. 160.]



economizer at the end where the flue gases pass to the chimney, after having given up a large portion of their heat to the water in the tubes, and the water leaving the economizer at the point where the flue gases coming directly from the boiler, enter the chimney in which the tubes are fixed.

There appears to be a difference of opinion between the makers of economizers as to the advantage of keeping the water in the tubes in circulation. Messrs. Carter have designed their special form of apparatus distinctly with the object of keeping the water in circulation; and, in addition, it is made to run in a thin stream over a thin metal surface, on the opposite side of which are the flames of the hot flue gases. Messrs. Green, on the other hand, state that they have gone very carefully into this matter, and that they do not find any advantage from keeping the water in circulation. It should be mentioned that the water is maintained in circulation through the economizers by the feed pump, but, as the author understands it, Messrs. Carter provide an additional circulation, within the economizer itself, and break up the mass of water very much more than Messrs. Green do. In Messrs. Green's apparatus, each tube contains a cylindrical column of water of about  $4\frac{1}{2}$  inches in diameter, while in Messrs. Carter's the water is only in a very thin stream.

In all forms of economizer it is now usual to take out about  $300^{\circ}$  of the heat of the flue gases, leaving  $300^{\circ}$  to  $350^{\circ}$  for the working of the chimney. As explained in connection with forced draught, it should be possible to considerably reduce this, if the heat could be economically employed, and improvement would appear to be in the direction of a larger absorption of the heat of flue gases, where economizers are employed, and the employment of a smaller number of tubes.

A point that should be noted in connection with economizers is given by Messrs. Green. Their economizer should never be supplied with water at a lower temperature than  $90^{\circ}$  F. As will be seen later, the difficulty is easily overcome by interposing a steam feed-water heater in the path of the feed water on its way from the supply to the economizer. Where this cannot be arranged, Messrs. Green provide a modification of their apparatus in which the water entering the economizer is heated by a small quantity of water from the hottest water of the economizer itself.

The objection to supplying the economizer with feed water at less than  $90^{\circ}$ , is, condensation of the steam that is present in the hot gases, and of the gases themselves, take place if water below this temperature is allowed to enter the tubes.

## Heating Air and Water by Economizers

It was mentioned in connection with the Ellis and Eaves system of forced draught, that air for the boiler furnaces is heated by the flue gases. In a modification of the economizer by Messrs. Green, it is arranged to heat air and water from the same set of gases on their way to the boiler. Two economizers are interposed between the backs of the boilers and the chimney, one for heating the water, and the other for heating the air. There is a reserve flue, or bye-pass, at the back of the two economizers, leading directly from the main flue at the back of the boiler to the chimney, that can be employed when the economizers are not in use. The two economizers are very similar in construction, but water passes through the tubes of one, and air through those of the other, the hot gases passing on the outside of both sets of tubes in succession, the water heater receiving the hot gases first, and they then passing to the air heater. A fan draws the air through the economizer tubes and delivers it to the ashpit or the stoke-hold. The air can be heated to any desired temperature, according to the quantity of heat that can be abstracted from the hot gases, but in Messrs. Green's practice it appears to be usual not to heat the air more than 200°. It must be remembered that if air and water are heated by economizers, unless a larger quantity of heat is abstracted from the flue gases, the temperature to which the water is raised must be less than that to which it would be if air heating was not resorted to as well, and as in other cases, it becomes a question as to which is most economical. Fifty-five cubic feet of air can have its temperature raised 100° for 100 heat units, while only 1 lb. of water will have its temperature raised the same number of degrees for the same number of heat units. The problem is rather a practical one, and has to be worked out in each case.

Certain care is necessary in using economizers. In frosty weather, for instance, if the economizer is in an exposed position, where the cold will penetrate to the tubes, they should not be left full of water when they are not in use, as otherwise the tubes will be cracked by the expanding ice in the process of formation.

Dampers are provided at each end of the bye-pass, and at each end of the economiser, enabling the economisers to be shut off when required, and they should be shut off when steam is not being taken from the boilers, and when steam is being got up, say at the beginning of a working day. Messrs. Green recommend that the draught of the boilers should be regulated by the main damper at the outlet end of the economizer, when economizers are employed, and not by the boiler damper, and that the outlet valve between the economizer and the boilers should not be closed when raising steam, nor during the

night, or at meal times, and that the boilers should be fed constantly, the boiler feed valves being kept open, and the feed being regulated by the inlet valve of the economizer. They also recommend that cold air should on no account be allowed to enter the economizer chamber. Unfortunately, as mentioned in connection with draught, air leakage is only too common through the brickwork of boiler flues, and it is only probable that the same thing will apply to the brickwork of the economizer chambers. If air leakage does occur, it will lower the efficiency of the economizer by lowering the temperature to which the feed water or the air is raised, because the leakage air passing into the economizer chamber will rob the flue gases of a portion of the heat that would otherwise pass to the economizer tubes, the air being itself raised to the temperature of the flue gases, and there being that much less heat available for heating the feed water, or the air for the boiler furnace. Remembering, again, that 55 cubic feet of air raised  $100^{\circ}$  in temperature, robs the flue gases of 100 heat units, and that it is quite possible to have a good many lots of 55 cubic feet entering the economizer chamber through cracks in the brickwork and imperfect mortaring, etc., and it will not be difficult to see how easily losses can arise.

## Steam Feed-Water Heaters

The apparatus to be described here are known generically as feed-water heaters, but the author prefers to call them steam feed-water heaters, in order to distinguish them from the economizer, which, it will be seen, is also a feed-water heater. There are two types of steam feed-water heater, the enclosed and the open type.

### The Enclosed Steam Feed-Water Heaters

The arrangement of the enclosed type of feed-water heater is very similar to that of the economizer, but very much smaller, and steam is used in the place of the hot gases. The apparatus consists usually of a cylinder, or in some cases of a rectangular box, with a number of tubes held between tube plates inside, and a space at each end. There is a space all round the tubes, and also between them. The arrangement of feed-water heaters varies. In the majority of cases the water to be heated passes through the tubes, while the steam that is to heat it passes through the space surrounding them. In some cases the reverse arrangement rules, the steam passing in the tubes, and the water passing on the outside. Exhaust steam from the engines or turbines is sometimes employed for heating the feed

water, either on its way to the condenser, or to the atmosphere, but more commonly that from steam pumps or other auxiliaries. It is a disputed question whether the exhaust steam from condensing engines should be employed for heating the feed water, the objection being that the steam will be throttled and a back pressure set up in the steam cylinder or the turbine. Messrs. Royle of Irlam, and other firms, recommend that feed-water heaters should be employed between the low-pressure cylinder and the condenser, and they claim that no back pressure will be produced, providing that the steam-way is sufficiently large; and in their apparatus they state that the area of the steam passages within the heater is several times that of the steam pipe.

Live steam from the boiler is also frequently employed where exhaust steam is not available, as it is found that, though additional coal must be burned to furnish the steam required to heat the feed water, and it looks as though it should be more economical to burn the coal to heat the

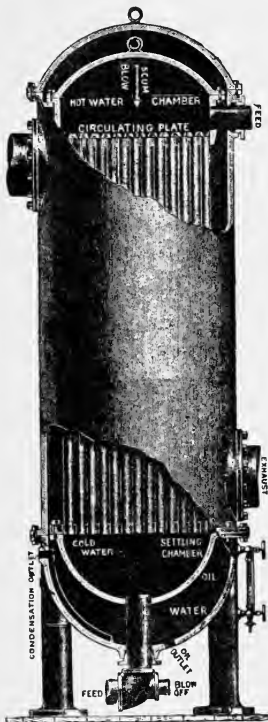

FIG. 56.—The Riblet Steam-feed Water Heater. The Water passes through the Tubes and the Steam on the outside.

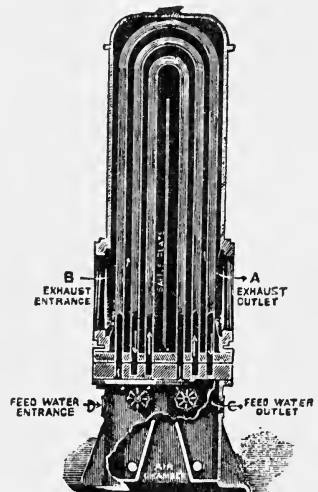

FIG. 57.—The Hardwick Steam-feed Water Heater. The Water passes through the Tubes as shown.

water directly in the boiler itself, the losses arising from defective circulation, if cold feed water is pumped into the boiler, are so great that the economy is on the side of the live steam heater.

In addition, where high boiler pressures are employed, as from 150 to 200 lbs. per square inch, and the engines or turbines are

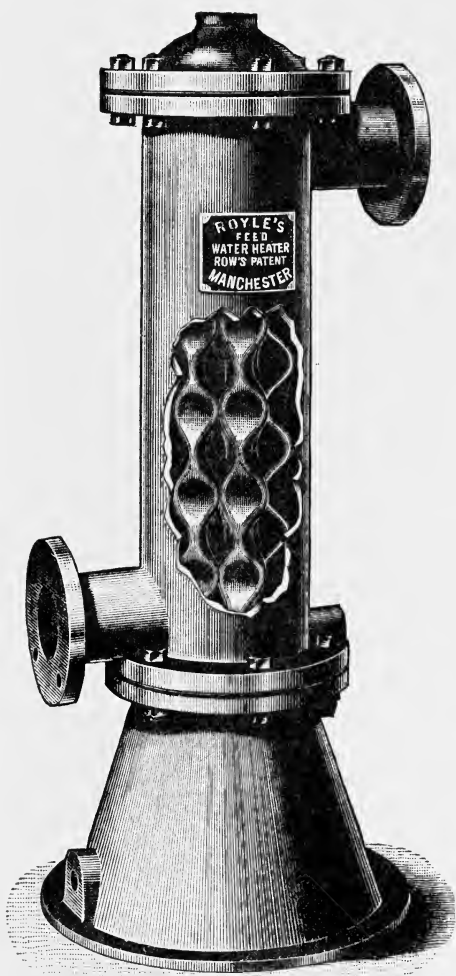

FIG. 58.—Royle's Feed-water Heater.

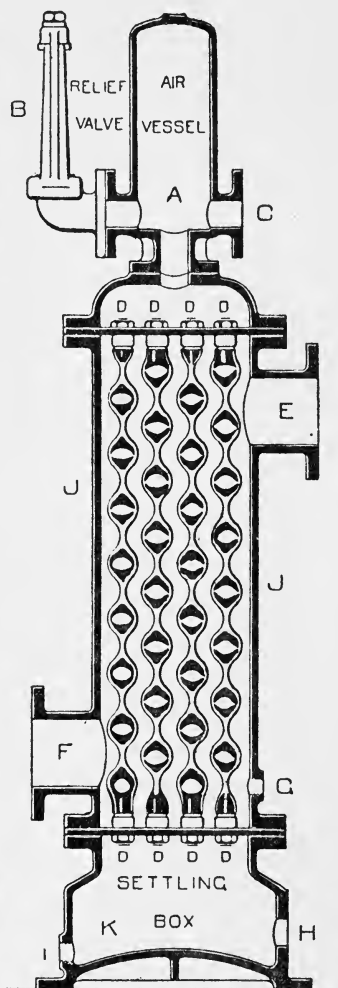

FIG. 59.—Vertical Transverse Section of Messrs. Royle's Feed-water Heater, showing the specially formed Tubes employed.

worked to the best advantage expansively, the exhaust steam has not sufficient heat remaining in it to raise the temperature of the feed

water to that of the water in the boiler. Thus, according to Messrs. Holden & Brooke's experience, with a boiler pressure of 150 lbs., while the temperature of the water in the boiler is 365° F., the temperature of the feed water heated by the exhaust steam is only 180°, and in these cases if only feed-water heaters are employed live steam must be used. If, however, economizers are employed, it will be evident that the feed-water heater is a useful auxiliary to the economizer, raising the temperature of the water considerably above the minimum temperature at which it should enter the economizer.

Some forms of feed-water heaters are shown in Figs. 56 to 61. The arrangement of the tubes in the feed-water heaters are various. Vertical tubes are very much in favour, as shown in Figs. 56 and 57, but horizontal coils of tubes are also employed, and are made by the National Pipe Bending Company of Newhaven, Connecticut.

The tubes also are various in form. The "Row" tube, made by Messrs. Royle of Irlam, Manchester, is shown in Figs. 58 and 59. As will be seen, it is an ordinary tube indented at equal distances throughout its length, alternate indentations being at right angles to each other, and each indentation being the same on opposite sides of the tubes. The indentations produce a very flexible tube, and it is claimed by Messrs. Royle that the surface over which the water passes being larger, the transmission of heat from the steam to the water is more rapid with their tube than with the ordinary vertical or coiled tube.

Another form of tube for feed-water heaters is the Wainwright corrugated tube, made by the Alberger Condenser Company of New York. In Fig. 60 is given heat-absorption curves with plain tubes, and Wainwright corrugated tubes, showing the claims made by the Alberger Company on its behalf. Messrs. Holden & Brooke make a special form of feed-water heater for use with live steam. It is shown in section in Fig. 61, and the special feature is a system of concentric tubes arranged so that the feed water passing through the apparatus has to flow in a very thin stream through the annular space between the concentric tubes, steam being present on each side of the annular space. From the figure it will be seen that there is the usual cylindrical main body with two sets of tube plates, the longer tubes being held by the top and bottom plates and the shorter tubes by the intermediate plates. There is also a diaphragm between the two lower tube plates. As will be seen from the drawing, the water enters by the inlet on the right, and is obliged to pass up through the annular spaces shown, down again through the annular space in another set of tubes, and so on, passing out by the outlet on the left, after having flowed through all the spaces between the concentric tubes. It will be seen also that there is only a live steam inlet but no outlet, the full latent heat being taken out of the steam, and it



being condensed after it has done its work, the condensed water being allowed to flow away by the drain at the bottom.

The feed-water heater acts to a certain extent as a purifier for the feed water, inasmuch as a certain portion of the substances that are held in suspension in the feed water are thrown down when the water

HEAT ABSORPTION CURVES

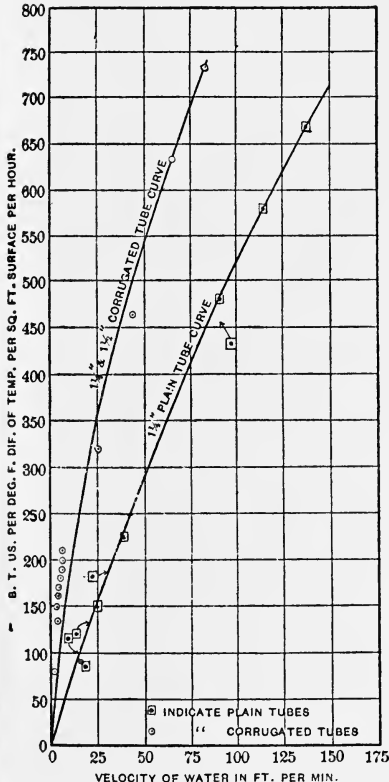

FIG. 60.—Wainwright's Curves for the Relative Heating Effect realized with Plain and with Corrugated Tubes.

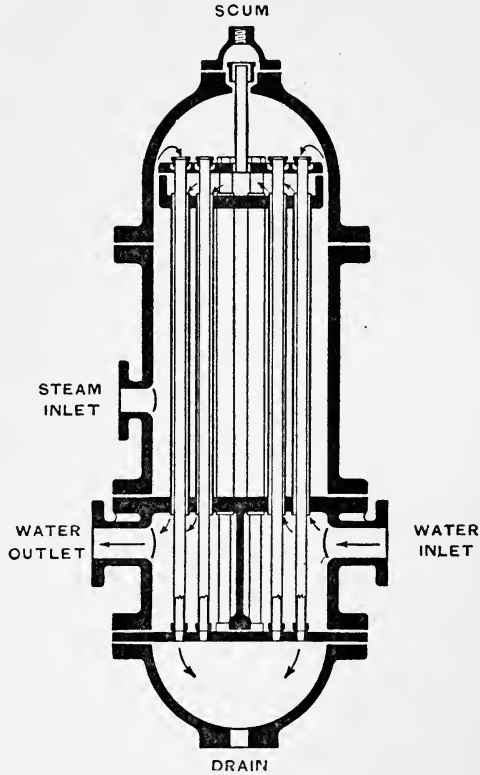

FIG. 61.—Messrs. Holden & Brooke's Live Steam-feed Water Heater. The Water passes in the annular space between the two sets of Tubes shown, the Steam passing on both sides.

is raised to a certain temperature, also some of the salts which cause what is known as the hardness in water are also thrown down; and in the best forms of feed-water heaters, arrangements are made in the water spaces for the deposit of the solid matters that are thrown down, and their removal from time to time through an aperture provided for the purpose. The usual arrangement is that shown in

Fig. 56, where the deposit falls to the bottom of the water space in the base of the apparatus, and is drawn off by the cock shown.

## Open Steam Feed-Water Heaters

The open feed-water heater is something on the lines of the jet condenser, to be described later on. It consists primarily of a vessel into which the water to be heated is delivered, usually in the form of a spray, and there it meets the exhaust steam, the latter giving up its latent heat to the water and raising its temperature. It will be understood that this apparatus is more economical in heat than the closed form of the feed-water heater, because the whole of the heat of the steam is delivered to the water in this form, whereas only a portion is delivered in the case of the closed heater. The objection to its use is that which is mentioned later in connection with the purification of feed water—the fact that the steam from reciprocating engines always carries a certain quantity of oil in a finely divided state, and this being delivered to the feed water is carried over into the boiler unless means are taken to separate it afterwards. On the other hand, some firms advise the use of this form, or of the closed form of heater in which the steam passes through the tubes, where the feed water contains considerable quantities of foreign matter or other impurities. This, however, has led to the development of special classes of combined feed-water heaters and purifiers, of which the Hoppes, made by the Hoppes Manufacturing Company of Springfield, Ohio, is one of the best known. In the Hoppes apparatus, which is shown on Plate 9A, there is the usual containing cylinder, fixed horizontally, and containing trough-shaped trays, or pans of thin sheet steel, placed one above the other. The water to be purified and heated is pumped into the upper tray. It is allowed to fill the upper tray and then trickle over the edge of the tray down the outside, and from the lowest part of the tray into the next one, which it gradually fills, trickling down the outside of the second tray into the third, which it fills, and so on. Exhaust steam or live steam is led to the cylinder, heating the water in the same manner as with other heaters, the water, after it has been heated being usually allowed to descend by gravity to the boiler it is feeding, and being led into the boiler below the water level. It is stated that Mr. Hoppes took the idea of the apparatus from the well-known action, so often seen in caves, by which stalactites and stalagmites are built up. The salts and other foreign substances contained in the water are deposited upon the steel troughs, upon which they gradually grow, the water passing on purified and heated. Plate 9B shows the deposit taken from a Hoppes feed-water heater fitted to a 3000 horse-power plant after thirty days' run. Plate 9C

shows the arrangements for fixing the Hoppes apparatus to a water-tube boiler.

The Simms Company of Erie, Pennsylvania, also make an open feed-water heater, somewhat resembling the Hoppes purifier, with which a filter is combined. It consists of the usual vertical cylinder, having trays in the upper portion, the trays being slightly inclined to the horizontal, and the water being made to pass over the trays in succession as it descends. The trays are heated by steam. The water, after passing over the trays and being heated, and to a certain extent purified, passes through a coke filter at the bottom, and from thence is taken to the boiler. It should be noted that where feed-water heaters are connected to pumps there should be an air vessel attached and a relief valve. The air vessel provides a cushion against the stroke of the pump, and the relief valve prevents the apparatus being subject to too high a pressure.

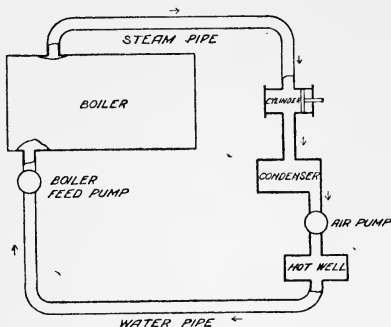

FIG. 62.—Diagram showing the Course of the Steam and Water, where the Condensed Steam is employed for the Boiler Feed.

The question of what water shall be employed in the feed-water heater is often an important one. In some cases the condensed steam water from a hot well, into which it is discharged from the condenser, is employed, and in others a portion of the circulating water from the surface condensers, which has already been heated to a certain extent, is used. The objection to the condensed water from the hot well is

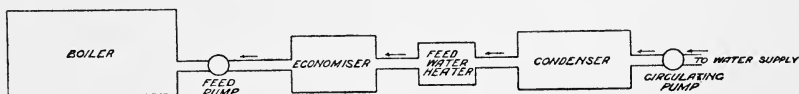

FIG. 63.—Diagram showing the arrangement where a portion of Circulating Water from the Condenser is employed as Feed Water for the Boiler, after being heated by Exhaust Steam and the Flue Gases. The remainder of the Circulating Water is allowed to run away, or is carried to the Cooling Tower.

that already mentioned—with reciprocating engines the exhaust steam contains oil. This does not apply to exhaust steam from turbines nor to the water that has been used in a surface condenser. Fig. 62 is a diagram showing the course of the water and steam where the condensed steam is used to feed the boiler, without any intervening apparatus; Fig. 63 the arrangement where a portion of the circulating

water from the condenser is used for the feed, and is heated by passing through feed waters and economizers.

## Feed-Water Pumps

The feed water, it will be understood, has to be forced into the boiler against the pressure of the steam in the boiler, which, it will be remembered, is communicated through the water and the steam in every direction, and therefore some form of pump or other apparatus has to be employed that will produce a pressure sufficient to overcome the boiler pressure. Broadly, feed-water pumps are on two lines. The ordinary ram or plunger pump of the two or three throw type is often employed, driven by its own engine or by an electric motor; and, again, special forms of feed pumps have been worked out by different firms, designed especially for the work. Injectors, described on p. 173, are also being used in place of feed pumps.

## Ram Pumps

In the ram or plunger pump there are one or more cylinders; usually, in the case of feed pumps, three cylinders, which may be fixed either vertically or horizontally, as convenient, each cylinder having a ram or plunger, which is virtually a piston moving to and fro inside the cylinder, just as the piston of a steam engine moves in its cylinder. As the plunger rises, the suction valve in the bottom of the cylinder opens inwards and allows the water from the suction pipe to pass into the cylinder. On the return stroke of the plunger, the weight of the water above it closes the suction valve, and the force exerted by the plunger opens the delivery valve, which opens outwards into the feed pipe, leading either directly to the boiler or to the feed-water heater or economizer. Messrs. Frank Pearn also make a double-acting boiler feed ram pump. The plungers of the ram pumps are moved by rods attached to them, similar to piston rods, the other ends of the rods being fixed to a crank forming part of a shaft, to which a pulley is attached, or that is directly connected to the revolving shaft of a steam engine or electric motor. When there are two or more cylinders the cranks of the cylinders are arranged with two, either  $90^\circ$  or  $180^\circ$  apart, and with three  $120^\circ$  apart, so that the effort made by the engine is evenly distributed throughout the revolution.

## Special Pumps

Special feed pumps are of various forms, designed principally to occupy small space and to work automatically. The Worthington is

one of the best known. It is a steam-driven pump; that is to say, there is a steam cylinder and a water cylinder fixed on one bed-plate, the two cylinders forming part of one casting, and the piston of the steam cylinder and the plunger of the pump being connected by one piston-rod. The steam cylinder receives steam from the boiler, or when steam is first being raised, from the auxiliary or donkey boiler. The pump cylinder is usually arranged double-acting, as it is called. It draws in water into one portion of the pump cylinder as the ram moves it in one direction, and at the same time forces water that was drawn in at the previous stroke through the delivery valve of the other portion. As the piston of the steam cylinder returns, the water that was drawn in on the out-stroke is forced out through the delivery valve on that side, and water is drawn in to the other portion of the pump chamber. In the Worthington pump there are two complete sets of steam and water cylinders, standing side by side, and it is arranged by means of a swinging rod that the action is automatic: the rod of one pump actuates the valve on the steam cylinder of the other pump, causing reversal of motion at the proper time, the steam cylinders being fitted with slide valves. The slide valve is explained in the chapter on "Steam Engines."

### The Pulsometer Feed Pump

The pulsometer pump is quite different from the usual run of pumps. It contains two chambers side by side, opening on to one steam pipe at the top, and having suction and delivery valves at the bottom. The connection between each of the chambers and the steam pipe is closed or opened by the motion of a spherical ball. When the ball is on the left, say, the admission of steam to the left-hand chamber is cut off, while the steam is free to enter the right-hand chamber, and the action of the apparatus is as follows:—Supposing the ball to be on the left and the left-hand chamber to be empty, a partial vacuum having been created by the condensation of the steam with which the chamber was previously filled, the water that is to be pumped runs into the chamber up to a certain height. Meanwhile steam has been entering the right-hand chamber and forcing the water that was in the chamber out through the delivery valve, and when the level of the water has reached the entrance to the delivery valve, the steam above is condensed and the ball at the top then rolls over and shuts off the supply of steam to the right-hand chamber, the steam then entering the left-hand chamber, forcing the water in front of it through the delivery valve, the suction valve having closed immediately the pressure of steam commenced. When the water reaches the level of the delivery valve,

the steam in the left-hand chamber rapidly condenses, the lowered pressure resulting causing the ball to roll over to that side, shutting off the steam on that side, the steam now entering the other side, which has meanwhile been filled up with water. The action of the apparatus goes on continuously as long as steam is supplied to it. It is of great service where the water contains foreign matter, as the valve does not clog as the valves of some pumps do. The ball valve as it rolls over and over, maintains itself and its seat in proper order, and keeps the steam passages as they should be.

There are two or three other pumps that have been designed on the lines of the pulsometer, known by various names, that are also available for boiler work. The pulsometer can be used in positions where it would sometimes be difficult to use other pumps, such as on a dockside and by the side of a river, and so on, being able to work when completely immersed.

### Electrically driven Boiler Feed Pumps

The great objection to some forms of steam feed pumps is the large quantity of steam they consume—as much as 200 to 250 lbs. per indicated horse-power in the steam cylinders. The same complaint in a minor degree is made against the engines driving three-throw feed pumps, since all small steam engines are wasteful in steam consumption, and this has led to the adoption, wherever electrical power is available, of the electric drive. On the other hand, some engineers do not like the electric drive, especially in electricity generating works, because if there is a large demand for current, leading to a certain fall of pressure in the generating station, the feed pumps are apt to feel it and to slow up more or less, while the boilers require feeding more energetically in order to keep up the supply of steam. It is possible, of course, to provide for this by suitable arrangements at the switch-board. Another objection made by engineers of works that are stopped at night and from Saturday to Monday is—the electrically driven pump cannot run until sufficient steam is made to drive a generator, while the steam pump can nearly always be driven from a small auxiliary boiler. On board ship what is called a “donkey” boiler is always carried for this very purpose, and for use when the ship is in dock. It is a small boiler, sometimes of the vertical type, something on the lines of a multitubular land boiler, in which steam can be got up very quickly, and which is employed for handling cargo, winches, etc., and its steam is, of course, available for anything, such as steam pumps, that may require it. In the electrically driven boiler-feed pump an electric motor is mounted on the frame of the pump, and its axle is geared to that of

the pump by spur and pinion gearing in the required ratio. The motor is supplied with current from the main switch-board, and its speed can be regulated by varying the current passing in its field magnet coils.

## Donkey or Wall Pumps

The wall pump, or the "donkey" pump, as it is sometimes called, is a very favourite form of boiler-feed pump, because it can be fixed in some convenient position out of the way.

As its name implies, it is fixed against the wall of the building, and usually carries the steam and water cylinders on one casting, which also forms the bracket or bed-plate by which it is secured to the wall, and there is also usually a small flywheel. In one form, made by Messrs. Pearn, the steam cylinder is above, with its slide valve, the water cylinder being below, and the air vessel required with pumps is between the cylinders and the suspending bracket, the crank shaft and the fly-wheel being supported by a loop from the junction of the steam and water piston rods.

## Injectors

The injector is another apparatus used for delivering the feed water to the boiler. It acts as pump and feed-water heater. It operates upon what is known as the injector principle, the most familiar example of which is the scent spray. Whenever air, steam, or gas is forced across the surface of a pipe containing either water, air, or gas, the friction of the air, or steam, on the surface of the water, or air in the pipe, causes a small portion to be drawn out of the pipe and to be forced along in the direction in which the stream of air or steam is passing. The passage outwards of the small quantity of air or water causes a lowered pressure within the pipe, this again causing the water or the air in the pipe to rise, and a small portion again to follow the first portion, and so a continuous stream is set up as long as the air or steam is passing across the mouth of the pipe. Similarly, if a stream of air, or steam, or gas, is forced through a passage in which it is surrounded either by air, water, or steam, a similar action takes place, the water or the air following the original stream, and a continuous stream being set up. The steam jets that have been described as inducing currents of air for furnace draught act on this principle. The jet of steam draws a small quantity of the air by which it is surrounded along with it in the direction in which it is going, that lowering the pressure behind it, and the pressure of the atmosphere outside forcing a continuous current of air along mingling

with the steam jet. In the case of the steam injector, which is understood to mean an apparatus for delivering a stream of water, a steam jet passes through a nozzle, as shown in Fig. 64, and the nozzle is surrounded by water, as seen. The passage of the steam jet causes a small quantity of air to accompany it in the direction in which it is going, this lowering the pressure in front of the water surrounding the steam nozzle. The pressure behind the water then forces the water around the nozzle forwards to take the place of the air which has moved forwards, and a continuous stream of water mixed with the steam, and therefore heated by the steam is the result.

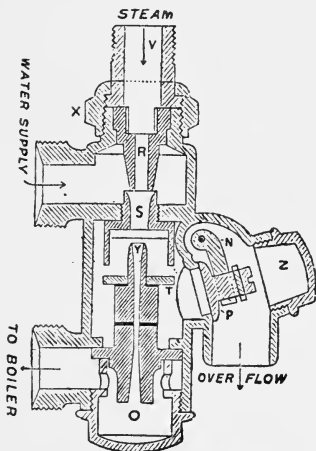

FIG. 64.—Sectional Drawing of Reverberatory Steam Injector. **R** is the Steam Nozzle, **S** the Cone through which the Water is drawn by the Steam. The Steam Nozzle is surrounded by the Water Stream.

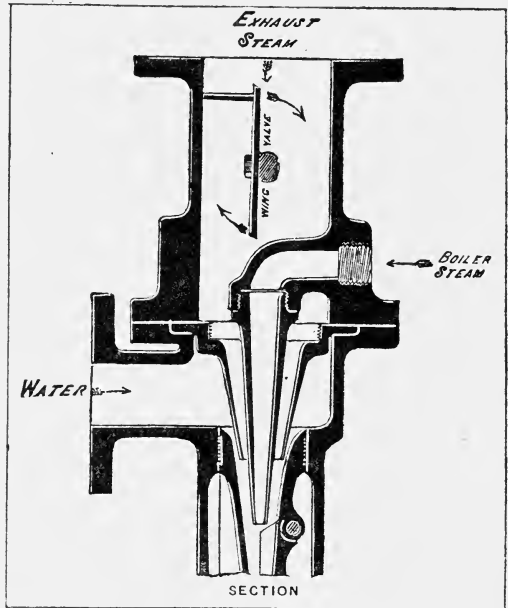

FIG. 65.—Section of Messrs. Davies & Metcalfe's Injector in which Exhaust Steam and Live Steam from the Boiler are employed. There are Two Steam Cones, one inside the other, both surrounded by the Outer Cone.

The pressure in the boiler against which the steam injector is able to work may be very much greater than that of the pressure of the steam passing in the nozzle of the injector, the reason of this being that a portion of the energy carried by the steam in the nozzle, in the form of velocity head, is converted, on meeting the stream of water, into pressure head, and in that way the pressure available for forcing the water into the boiler is considerably increased. With exhaust steam, for instance, at only atmospheric pressure, the injector is made



to feed into boilers working at as much as 95 lbs. per square inch, while with the assistance of a small jet of live steam from the boiler itself, as will be explained, the feed is accomplished up to pressures as great as 300 lbs. per square inch.

It will be understood that this is another case of the conversion of energy from one form to another. The apparatus, sections of which are shown in Figs. 64, 65, 66, and 67, consists of two cones, one carrying steam nozzle and the other being arranged as a combining chamber,

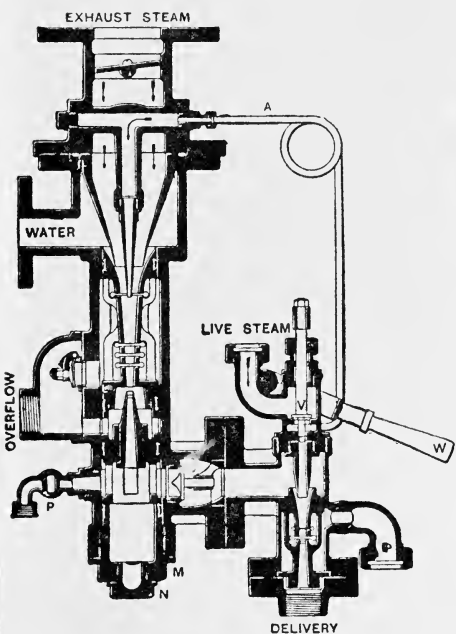

FIG. 66.—Section of Messrs. Holden and Brooke's Injector for Live Steam and Exhaust Steam.

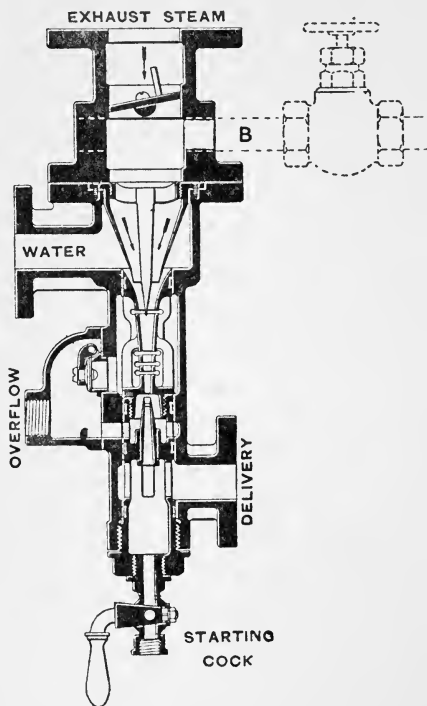

FIG. 67.—Messrs. Holden and Brooke's Injector for Exhaust Steam, in which both Water and Steam are controlled by One Handle.

where the steam and water join to pass on to the delivery port. The water inlet, as will be seen, surrounds the cone carrying the steam nozzle, and it is arranged, when the injector is started, that steam is admitted at the same time as a certain flow of water is also admitted, and a stream of water, heated by the steam and passing to the delivery port, is gradually formed. It will be noticed that there is an overflow aperture shown in the drawings. This is for the purpose of allowing the passage of the water which first passes

through the apparatus, and which is not heated and has not come under the influence of the moving jet of steam, to pass harmlessly away. When the stream is set up, the overflow ceases, and should the steam jet fail from any cause, and therefore the stream of water passing to the boiler be broken, the water coming from the water inlet passes by way of the overflow.

It will be understood that, as usually arranged, there are two pipes leading to the injector, one bringing steam and the other bringing the water, as shown, and a third leading to the boiler, carrying the heated feed water, the steam and water pipes having their own controlling cocks. In some forms of apparatus, however, the whole arrangement is combined in one, with one controlling handle or regulator, the steam nozzle and the water supply being connected together by a coarse-pitched thread, both of which are moved by the regulator handle, as shown in Fig. 67. As explained above, the injector is worked by exhaust steam, where that is available, but it is also worked by live steam directly from the boiler, and, as mentioned, also by a combination of live steam and exhaust steam. In one form of the latter, made by Messrs. Davies & Metcalfe, shown in Fig. 65, there is a second steam nozzle, inside the first, and of very much smaller bore, this smaller nozzle being supplied with live steam from the boiler, and its office is to act as an injector upon the exhaust steam, just as the ordinary steam jet acts upon air or water through which it is passing. The small jet of live steam causes a larger quantity of exhaust steam to be carried into the apparatus, this enabling the water to be forced into the boiler at a higher pressure than would otherwise be possible. Messrs. Holden & Brooke also make an apparatus in which live steam is used as a supplementary injector. It is shown in section in Fig. 66, and from the drawing it will be seen that the delivery passage of the exhaust-steam injector forms the inlet for the auxiliary live-steam injector, the live steam forcing the already heated water from the exhaust-steam injector into the boiler at a higher pressure, and with a higher temperature.

In practically all forms of injector, the regulation of the water supply is carried out by the position of the steam nozzle. In Messrs. Holden & Brooke's combined apparatus, the steam nozzle carries a conical valve, which closes the passage to the combining cone, and when the regulating handle is turned this valve lifts and allows steam and water to pass into the combining cone. In other forms of their apparatus, and also in Messrs. Davies & Metcalfe's, the quantity of water is regulated by merely pushing the steam nozzle forwards, or withdrawing it, by moving the regulating handle, the water passage being decreased or increased by this.

With exhaust steam it is claimed that water can be delivered to the boiler up to a temperature of 190° F.; while with the addition of

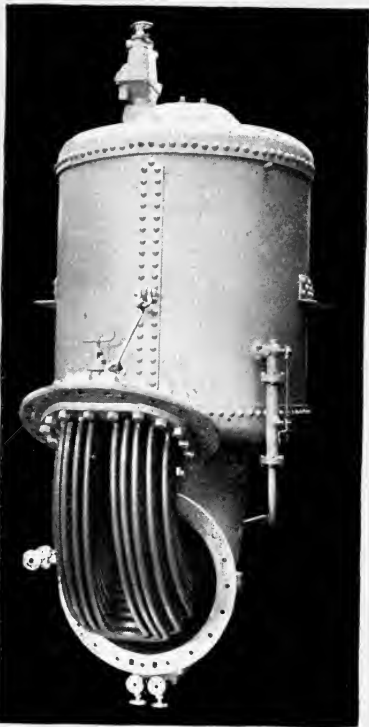

PLATE 10A.—Evaporator made by the Central Engineering Works, Hartlepool.

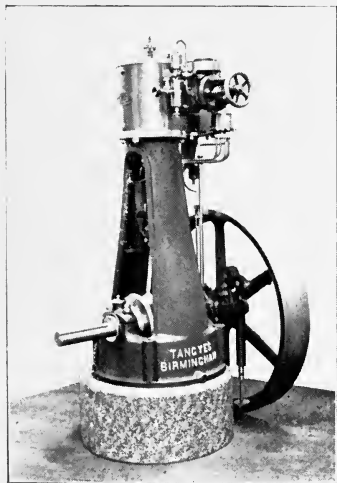

PLATE 10D.—Single Cylinder Vertical Engine, made by Tangey.

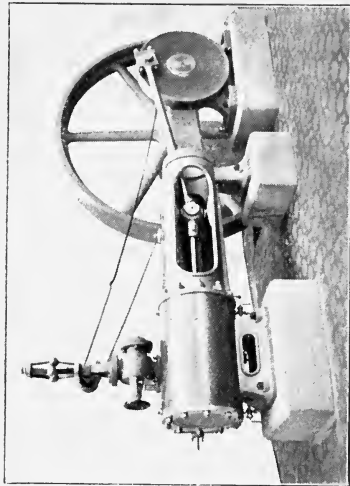

PLATE 10b.—Tangey Single Cylinder, Horizontal Engine, with Pickering Governor.

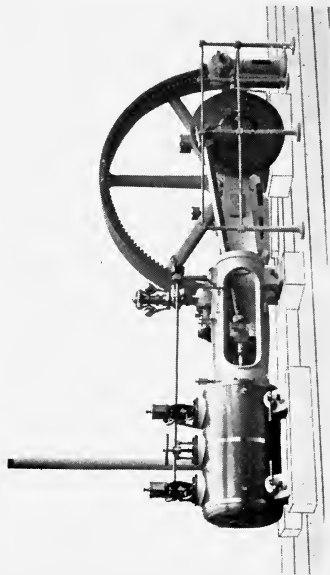

PLATE 10c.—Marshall's Single Cylinder Horizontal Engine, with their Trip Valve Gear.



live steam, as explained, it may be introduced at any temperature desired.

The injector may be made to take water from a tank at a higher level, the water flowing by gravity into the injector, and thence being forced into the boiler; or it may lift water from a tank or any supply at a lower level, and then force it into the boiler, but in that case the quantity of water the injector can deliver is reduced. Thus, when the water has to be lifted 6 feet, the quantity the injector is able to deliver is reduced about 10 per cent.; with a lift of 12 feet, it is reduced 25 per cent.; and with 18 feet, 35 per cent.

The quantity of water the injector can deliver depends directly upon the pressure of steam behind it, but the following table, given by Messrs. Babcock & Wilcox for their live steam injector, will show the matter pretty clearly. The injectors, it will be seen, are made to deliver from 122 gallons per hour with a boiler pressure of 120 lbs., up to nearly 12,000 gallons per hour with a boiler pressure of 200 lbs., the quantity that can be delivered increasing with the boiler pressure, but not in proportion to it.

TABLE XVII.

QUANTITIES OF WATER THAT INJECTORS WILL DELIVER AT DIFFERENT PRESSURES

Size.	Size of pipes and fittings.	Pressure of steam.				
		120 pounds.	140 pounds.	160 pounds.	180 pounds.	200 pounds.
Maximum delivery in gallons per hour.						
Inches.	Inches.					
2½	½	122	131	141	149	158
3	½	196	211	227	241	257
4	1	348	376	408	426	453
5	1	545	587	630	666	703
6	1½	783	846	905	953	1,020
7	1½	1067	1152	1,232	1,304	1,389
8	1½	1393	1505	1,607	1,705	1,820
9	1½	1763	1905	2,037	2,159	2,302
10	2	2177	2352	2,512	2,738	2,991
11	2	2633	2846	3,041	3,258	3,507
12	2	3136	3387	3,620	3,840	4,098
13	2½	3680	3975	4,250	4,506	4,807
14	2½	4267	4610	4,928	5,226	5,576
15	2½	4900	5292	5,656	5,998	6,320
16	3	5575	6022	6,435	6,825	7,283
17	3	6291	6798	7,680	7,728	8,244
18	3	7055	7633	8,148	8,636	9,208
19	3	7861	8492	9,096	9,792	10,584
20	3	8710	9410	10,048	10,952	11,964

The temperature at which the water is delivered to the injector

affects the quantity the injector will force into the boiler. The higher the temperature at which the water is delivered to the injector, the smaller the quantity the injector can handle. The following table, given by Messrs. Holden & Brooke, shows the effect of higher temperature of water upon the delivery. It will be seen that with a boiler pressure of 100 lbs. per square inch, the injector, according to their experience, ceases to work reliably when the feed water is delivered to the injector at over 120° F. There is a critical temperature with every boiler pressure at which the injector ceases to work reliably, the temperature falling as the pressure rises.

TABLE XVIII.

## EFFECT OF HOT FEED WATER ALONE UPON CAPACITY.

Example showing the diminution in capacity of injectors caused by the use of hot feed water. The figures refer to an injector fixed non-lifting and working with and against a boiler-pressure of 100 pounds per square inch.

Temperature of feed water entering the injector. Degrees Fahr. )	50°	60°	70°	80°	90°	100°	110°	120°	125°	130°
Percentage of diminution of delivery. )	0	1½	3	5	7½	10½	13½	19½	24	100

The following table, given by Messrs. Holden & Brooke, shows the temperatures up to which their injectors will receive feed water.

TABLE XIX.

## CRITICAL TEMPERATURES OF FEED WATER, WITH DIFFERENT PRESSURES.

Boiler pressure. Pounds.	Temperature at which injector will take feed water (fixed non-lifting).
25 } . . . . .	150° Fahrenheit
30 } . . . . .	150°    ,,
35 . . . . .	135°    ,,
80 . . . . .	125°    ,,
100 . . . . .	105°    ,,
150 . . . . .	80°     ,,
250 . . . . .	

## Feed-Water Regulators

One of the troubles in connection with boiler plant is the efficient control of the feed. If the feed water enters the boiler in too great

quantity, the steam pressure must go down; and, on the other hand, if it is insufficient in quantity, steam cannot be maintained. The flow is regulated by the "check valve," worked by hand, but devices have been arranged for controlling the supply automatically. One of these shown is made by the Williams Gauge Company of Pittsburg, U.S.A. It consists practically of a float, carried inside a vessel containing water, fixed on the front of the boiler, and in which the water will be at the same level as in the boiler. It is practically the water-gauge of the boiler. The water-gauge is carried on its front, and the gauge cocks at the side. It is arranged that as the level of the water rises and falls, the float rises and falls with it, and closes or opens the steam admission valve that is working the feed supply. It is also arranged that, should the pump fail, the feed-water regulator sounds a whistle until attention is called; and should the regulator itself fail, an alarm is sounded when the water is at the maximum height it is designed to work with.

## Purifying the Feed Water

From what has been said in previous portions of this and the first chapter, it will be understood that the purity of the water that is employed in boilers for raising steam is of enormous importance. As explained in the first chapter, water has the important, and, so far as boiler work is concerned, the troublesome property of not only dissolving portions of the rocks, earths, etc., over and through which it flows, but also of carrying minute portions of them in mechanical suspension. Every one is familiar with the worn surfaces of rocks in river beds. Part of the wearing is due to solution of the substances of which the rocks are composed, and part again is often due to attrition, to the wearing away and carrying off of minute particles of the substances in the same chemical condition as they existed when forming portions of the rocks. In addition to this, all water supplies that are available for boiler feed are liable to the presence of organic matter. The water supply of towns is obliged to be filtered from this cause, and water-works engineers know that at certain times of the year, such as in spring and early summer, and again in autumn, large quantities of vegetable matter find their way into the springs and rivers from which water supplies are taken, and a considerable quantity remains, even after filtration. Prof. Thurston estimates that from water that is considered to be very pure, a 100 H.P. boiler will receive as much as 90 lbs. of foreign matter per hour; while from other sources not as pure, as much as 1 ton per hour is sometimes carried in, and has to be got rid of.

In addition to the matter held in suspension, as described, the water has also salts of calcium and magnesium, which go to give it what is termed "hardness."

The term "hard water" is familiar as applied to water that does not lather with soap in the ordinary way, and the relative degree of hardness of different kinds of water is measured by the quantity of soap which it absorbs uselessly before it commences its work of cleansing, etc. The hardness of water is measured in degrees, though the measurement is a very arbitrary one, and the degrees are to be understood as something quite different from those used in connection with circles, etc. A degree of hardness in water means that a gallon of the water contains sufficient salts in solution to decompose as much soap as would be decomposed by one grain of carbonate of lime (chalk). Thus water is said to have 10° or 15° or 20° of hardness, as the case may be, when it contains the quantities of salts per gallon that will decompose the same quantities of soap as 10, 15, or 20 grains of chalk.

Hardness of water again is divided into temporary hardness and permanent hardness. Temporary hardness is caused principally by the presence of the bi-carbonates of lime and magnesia. By the bi-carbonate is meant the salt which contains two chemical equivalents of carbonic acid to one of lime or magnesia, the carbonate containing only one chemical equivalent of carbonic acid combined with one chemical equivalent of lime or magnesia. Temporary hardness is got rid of by raising the temperature of the water in which the bi-carbonates are dissolved to 320° F., or by the addition of lime, the lime combining with the second equivalent of carbonic acid and forming carbonate. At the temperature mentioned, one of the equivalents of carbonic acid is driven off as a gas, leaving the remaining salt in the form of the carbonate, which is not soluble in water, and which is therefore deposited, if suitable means are provided for it, in the vessel in which the operation takes place. Permanent hardness is caused by the presence of the chlorides and sulphates of lime and magnesia, and some of these are not driven off by raising the temperature, but are usually got rid of by chemical action. If the chlorides and sulphates and carbonates are not removed from the water before it enters the boiler, they are deposited upon the water side of the heating surfaces, the outsides of the flues, furnaces, etc., in the Lancashire boilers, and the inside of the boiler shell, and on the inside of the tubes of water-tube boilers, with the result that a scale is built up, as already explained, which resists the passage of heat through it.

The sulphates and chlorides are removed by the addition of carbonate of soda, a carbonate of lime being formed, which, as explained, is deposited, and a sulphate of soda which does not form



a scale. There are several forms of what are called water softeners, the principal of which are described below.

### **Other Scale-forming Substances**

In addition to the organic and other matters held in suspension, and to the salts held in solution, there are other matters which have a very serious effect upon the working of the boiler, and upon the formation of scale. As will be seen later, when describing engines and their working, it is necessary to employ oil for the lubrication of reciprocating engine cylinders, and a small quantity of the oil is continually carried over with the exhaust steam to the condenser and to the feed-water heater, where these are employed, with the result that, unless means are taken to prevent it, a very difficult matter if the condensed water is used for feeding the boiler, a portion of the oil remains in the feed water and works its way back into the boiler. It has been found that a very thin layer of oil on the surface of the furnace crown, for instance, offers such a high resistance to the passage of heat from the furnace gases to the water above them, that the crowns of the furnaces often become very dangerously heated indeed, the heat not being able to escape to the water, and serious trouble sometimes resulting. In addition to this, the minute quantities of oil combine with the sulphates and carbonates, and sometimes with the organic matter, if it is allowed to remain in the water, the scale so formed being of great tenacity and hardness, and giving considerable trouble to remove.

Another source of trouble in boilers is electrolytic action. The different parts of the boiler, it will be remembered, are subject to the action of the hot gases at different temperatures, and consequently the metal portions of the boilers at these points are themselves at different temperatures, and this leads to the formation of a galvanic battery, there being a difference of electrical pressure between the iron or steel at the higher temperature and that at the lower temperature. This, together with the presence of water, particularly when the water contains salts in solution, leads to the passage of electric currents from one part of the boiler to the other, through the water, and to the eating away of the boiler at those portions, generally the hotter portions, from which the current sets out.

### **Methods of Removing Foreign Bodies, etc.**

The case of the feed-water heater has been mentioned above, in which provision is made for removing the foreign bodies that are

thrown down into the chamber provided for them, also in describing several of the boilers, mud drums and scum cocks were also mentioned. The mud drums are for the reception of all the matter held in suspension, and all that can be arranged to be held in suspension, by the action of the boiler, and are fixed at the lowest point, and often well below the boiler, in order that all of these substances may gravitate there. In Lancashire boilers the lower part of the boiler below the furnace is the spot to which these substances usually gravitate. Scum cocks are fitted to the lower part of the front of the Lancashire boiler, and to the lower part of the mud drums of water-tube and other boilers. When the scum cock is opened, the pressure of steam in the boiler, which, it will be remembered, is communicated by the law governing pressures in fluids, to all parts of the fluids in the boiler, forces the semi-solid substances—the scum, in fact—out through the scum cock into receptacles provided for it.

## Water Softeners

Water softeners are practically constructed all on the same lines, with the usual variations by different inventors. The common practice in all of them is to add to the water to be softened a definite quantity of hydrate of lime, and carbonate of soda. Success in removing the substances which make water hard, depends very largely upon the reagents, as they are called, the lime and carbonate of soda being added in proper proportions, and therefore the manufacturers of all water-softening apparatus ask, as a preliminary, that the water shall be submitted to them for analysis, so that they may know the proper proportion of the reagents to add. If too little of the reagents are added to the water to be softened, it will be evident that a portion of the substances causing the hardness will remain; and, further, there is always the possibility of chemical action taking place between the new substances formed and the remainder of the sulphates or chlorides, in the presence of heat, and in the presence of the oil and organic matter that is sometimes found there. On the other hand, if too much of the reagent is added, there will be a surplus of it in the water, and in some cases this will have a deleterious effect. In all of the apparatus made, therefore, one portion is devoted to measuring definite quantities of the reagents, against definite quantities of the water to be softened. A second equally important requisite in the water softener is the thorough mixing of the reagents with the water to be softened. It will be quite evident to any one who has observed the action of the solution of different substances in water, that time is always necessary for

complete solution to be accomplished, though the time may be considerably lessened by stirring, and other methods; and, consequently, in all of the apparatus some form of stirrer or mixer occupies a prominent position.

The next important part of the apparatus is that in which the separation of the new substances that have been formed, and that are purposely made insoluble in the water, takes place.

In nearly all of the apparatus a filter forms an important feature in the last part of the operation. The filter is usually formed of wood wool.

In some of the water-softening apparatus, steam is used to heat the water, and to throw off the carbonic acid, as explained on p. 180, while others claim that the whole process is carried on without the addition of heat. In one apparatus, the Archbutt-Deely, made by Messrs. Mather and Platt, the water is also charged to a small extent with carbonic acid, after it has been softened. In one apparatus also, the Harris-Anderson, which is intended to remove the oil from the water, as well as to soften it, sulphate of alumina and carbonate of soda are added to the water in place of lime and carbonate of soda.

## The Archbutt-Deeley Water Softener

The Archbutt-Deely apparatus, which has been worked out by the engineers of the Midland Railway, is intended mainly for dealing with large quantities of water. It consists of two tanks which are used alternately, the water to be softened being treated in one tank, while the softened water is being drawn off from the other. In the lower part of the tanks are two sets of steam pipes, and above the main tanks is a small tank for chemicals, in which definite quantities of quicklime and carbonate of soda are boiled by means of live steam, the proportion of the chemicals being regulated according to the hardness of the water. The tank to be operated upon is filled by means of a pump, and then by the aid of steam the prepared chemical solution is forced into the water, a current being set up in the water in the tank, and the chemical solution being gradually drawn down through a pipe provided for it, from the tank in which it was prepared, and being drawn into the circulating current in the main water tank, and gradually mixed with the water to be softened. One special feature of the Archbutt-Deely apparatus is the method by which precipitation of the foreign substances is obtained. The mud, as it is called, from previous bodies of water that have been treated, is allowed to remain on the bottom of the tank, and when the chemical solution has thoroughly mixed with the

water, the mud precipitate is stirred up by means of air bubbles, forced from the lower row of pipes in the tank by the aid of steam. The disturbance of the old precipitate is stated to greatly accelerate the precipitation of the new matter that has been thrown out of the hard water by the chemical reagents, and that is in a very finely divided state, and will take a long time to settle unless means are taken to assist it. When the old precipitate, which consists of coarse particles, is stirred up, the fine particles of the new precipitate attach themselves to the coarse particles, and the whole subsides to the bottom by gravity, in the usual way. After the air has been operating for a few minutes, the time varying with different waters, the steam is turned off, and the precipitate is allowed to settle. It is found that the whole will settle to the bottom, and that the water, even to a depth of 6 feet from the surface, is clear and pure, and does not contain more than one grain of suspended matter per gallon. After the water has settled, the clear portion is drawn off and carbonated by means of fuel gas, from a coke stove, the gas being blown into the water by the aid of a steam nozzle, and being caused to mix with the water by means of baffles. Messrs. Archbutt & Deely state that uncarbonated softened water is liable to form a deposit in pipes, and especially in the feed apparatus of steam boilers, and it is for this reason they adopt the carbonating process. The mud is removed from the tanks from time to time, through mud doors, or by steam lifters.

### The Criton Water Softener

In the Criton water softener, made by the Pulsometer Company, no heat is employed. The apparatus is shown in section in Fig. 68. It will be noticed that there is a tank for lime water on the left, with a ball cock for filling it, and an overflow trough. Also that there is a tank above, marked syphon tank, and alongside of it another marked soda tank. The pipe bringing the hard water is seen dipping into the syphon tank, and a float, dipping into the syphon tank also, controlling by means of a system of levers a plunger, called in the drawing a displacer, in another small vessel below the soda tank. It will be noticed also that there is a plunger, also called a displacer, in the upper portion of the lime-water tank. On the right of the drawing will be noticed a larger vessel, marked settling tank, with a vessel at the top, open above, and having a pipe leading from the bottom to the bottom of the settling tank. Pipes will be noticed also leading from below the syphon tank, and from the small tank at the side of the soda tank, into the vessel above the

settling tank, which is called the mixer. The operation of the apparatus is as follows. The syphon tank is filled from the water inlet, the lime-water tank having also been filled from the same source, and having a quantity of lime dissolved in it. As the level of the water in the syphon tank rises, it raises the float shown, this depressing the plunger in the small tank by the side of the soda tank, and causing a quantity of the soda solution, which has been made in the soda tank, to pass into the mixer. At the same time the plunger in the lime-water tank is pushed downwards, causing a certain quantity of lime water to flow over the trough shown into the mixer, the hard water from the syphon tank flowing also through the pipe shown, the whole mixing together, and passing downwards through the pipe in the settling tank to the bottom. A large portion of the impurities that have been displaced by the chemical action are claimed to settle on the bottom of the settling tank, and are removed from time to time through the tap shown on the right. The water rises in the settling tank, passes out through the pipe shown at the top, into the filter, and down through the filter to the outlet. The filter is arranged to be cleaned, without removal, by a reverse current of water through the valves shown.

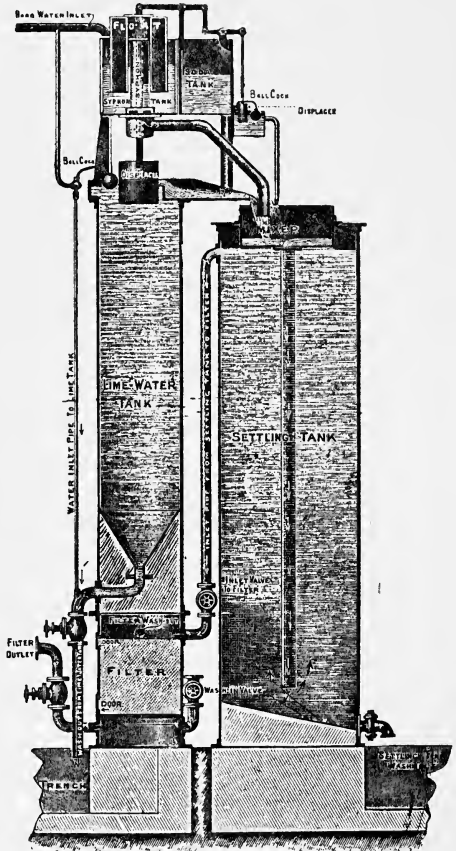

FIG. 68.—Section of Criton Water Softener. The Syphon Tank which receives the Water to be softened is seen at the top, where the Soda Tank is also fixed, the Lime-water Tank and the Filter and Settling Tank being below.

## The Reisert Water Softener

In this apparatus, which is made by Messrs. Royle of Irlam, there is the usual cylindrical main chamber, with a tank above, and a conical-shaped vessel on the right. The water to be softened enters the tank at the top, which is divided into three chambers, one for lime slaking, one for making a soda solution, and a third for the water by itself. The conical-shaped chamber is called the lime saturator, and its office is to prepare the solution of lime water to be employed in the softening process. Water enters the lime saturator from the middle chamber of the water tank, through a micrometer valve marked, and it passes directly down a central pipe, to the bottom of the chamber, the slaked lime being delivered some little distance from the bottom of the chamber, by a pipe and funnel from the lime chamber. The water delivered from the bottom of the central pipe passes upwards, its velocity gradually decreasing as the diameter of the chamber increases, and it is claimed that by this method the water becomes thoroughly saturated with lime, any undissolved lime particles falling to the bottom. On the left there is a similar chamber, but of rectangular shape, into which the solution of soda is delivered by a pipe and cock, water passing into another chamber at the same time, through another micrometer valve in the central water chamber, and the pipe attached to it. Small pipes lead from the top of the lime saturator, and from the soda solution chamber to a distributing tank, which is held inside of the main cylinder, the water to be softened also passing to the same chamber through the micrometer valve, in the central portion of the tank above, and the pipe attached to it. The water to be softened and the solutions of lime and soda that are to soften it are delivered in definite quantities into the middle chamber of the water tank, passing down through it, and up through the body of the liquid which fills the main cylindrical chamber, and from there the mixed water passes down a central pipe to the under side of the filter at the bottom. After passing through the filter the water is delivered to a tank on the left. There is in addition, a syphon tube, on the right, connected with the tank on the left by the small pipe, and one of the features claimed in connection with the Reisert apparatus is, the automatic cleaning of the filter. It will be understood that a certain amount of precipitation takes place in the lower part of the main cylinder, and that any precipitates remaining are absorbed by the filter, whose pores gradually become filled up. As the passage of the water through the filter is checked, as the pores become filled, the liquid rises, and when the resistance offered by the filter reaches a certain figure, a syphon is formed, reversing the

direction of the water through the filter, cleansing the filter, and carrying off the precipitate by a cock provided for it.

For locomotive and tubular boilers, in the Reisert water softening apparatus, lime is used in conjunction with carbonate of barium.

## The Bruun Lowener Water Softener

This apparatus is made in this country by Messrs. Lassen and Hjort. It is shown in Fig 69. The water is led into one of two

chambers of the oscillating receiver C, which is pivoted over the vessel B in which the principal action takes place.

Above the oscillator is a semi-cylindrical tank, in which the reagents are held, consisting of lime milk and carbonate of soda.

The makers state that the lime milk that is used has a strength of 10 per cent., and that it is made from freshly burned lime.

The chemicals are kept in constant motion within the semi-cylindrical vessel by means of the agitator shown.

At the bottom of the vessel carrying the chemicals is a valve, which is opened by a system of levers at every turn of the oscillator.

When one of the vessels of the oscillator is full, it tips over, and empties its contents into the mixing chamber B below, and at the same time a definite quantity of the lime milk and

carbonate of soda, thoroughly mixed together, are delivered to the mixing chamber. The water and the reagents are kept in motion

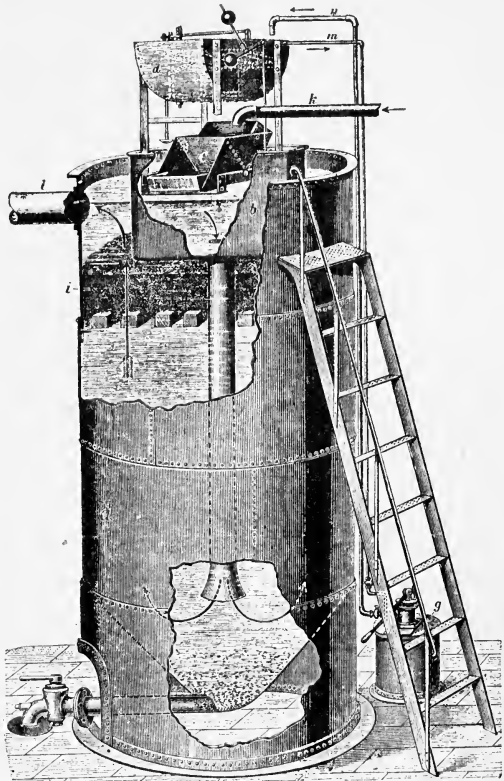

FIG. 69.—Vertical type of Bruun Lowener Water Softener, with Parts of the Containing Vessel cut away to show the interior. *c* is the Oscillator; *b* the Mixer; *i* is the Filter, at the top.

in motion

within the mixing chamber by means of a plate fixed to the bottom of the oscillator. From the mixing chamber the water passes to a heating chamber, and which is provided with a steam nozzle, the temperature of the water being raised to 130° F. Some of the foreign matters are precipitated in the heating chamber. From the heating chamber the water passes into the settling tank, where precipitation of the foreign substances takes place, and from thence it passes up through the filter I, which is made of wood wool, and thence to the boiler or feed pump, etc.

### **Guttman Water Softener**

In the Guttman apparatus, which is made by Messrs. Babcock and Wilcox, there is a chemical tank at the top of the apparatus, into which the quantity of the usual chemicals, sufficient for the day's work, is put, the tank then being filled with water. Below the chemical tank stands the mixing or reaction tank, into which the water to be softened is carried, a certain quantity of the solution of the reagents also passing into it from the chemical tank, the admission of water and reagents being controlled by valves. The water and solution in the reaction tank are raised to boiling-point by the aid of steam delivered to the tank by means of injectors, the whole being thoroughly agitated at the same time. The water flows from the reaction tank into the filter tank, which is arranged in steps, the bottom of each step forming a filter, and the water being caused to take a zigzag course by the division plates being arranged to leave spaces for the water alternately at the top and bottom. A certain amount of precipitation takes place as usual in the reaction tank, and the remainder is carried out in the filter tank, by successive steps, as explained. From the filter tank the water passes into the storage tank, where it should be ready for use.

### **Doulton's Water Softener**

The special feature of Messrs. Doulton's apparatus is the arrangement for mixing the chemicals with the water to be softened. This portion of the apparatus is shown in Fig. 70. The hard water is led in through the pipe at the top of the tank on the left, into the tank shown, which contains a float W, which by means of the lever L, and the cocks F and N, control the supply of the chemicals from the tank Y on the right. When the tank G on the left has been filled to a certain height, and the float W has thence been raised to a certain height, the lever L opens the cocks in the pipe leading



from the tank Y, and a certain definite quantity of the reagents pass into the mixing chamber, shown between the two tanks. At the same time the hard water from the tank G is discharged through the shoot Q into the mixing chamber, where it is given a whirling motion, this motion causing the required mixing of the reagents with

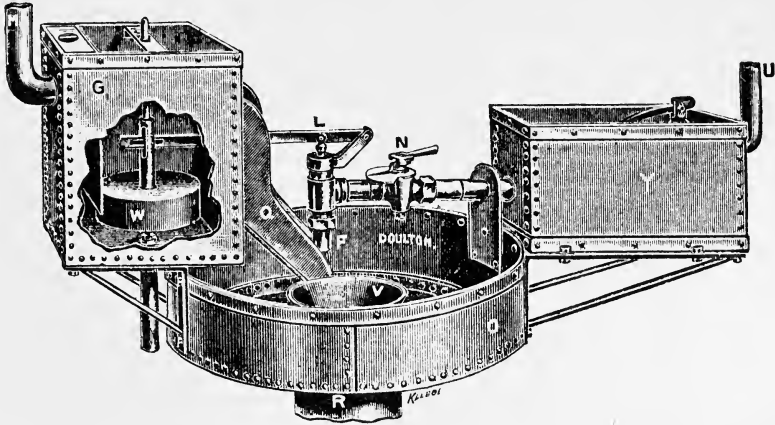

FIG. 70.—Mixing portion of Doulton's Water Softener. Y is the Chemical Tank; G the Tank receiving the Water to be softened.

the water. When mixing has been effected, the water and reagents pass through the funnel V, down to the bottom of a settling tank, at the bottom of which precipitation takes place, the water then rising through a filter at the top and passing on.

## The Kennicott Water Softener

In the Kennicott water softener there is a cylindrical steel tank, having a water wheel at the top, over which the water to be softened passes, the power delivered by the water being made use of to raise the reagents to the top of the tank. Tanks containing the reagents are also fixed above the main tank. The reagents pass into the water wheel, with the water to be softened, thence down through a pipe in the centre of the apparatus, to the bottom of the chamber, from which they turn and rise through a series of inclined perforated baffle plates, any precipitate which has not been left at the bottom of the tank being caught by these plates, from which it falls off to the bottom of the tank. The water finally passes through a wood-fibre filter at the top of the tank.

## The Desrumaux Water Softener

In this apparatus there are two tanks, one called the saturator, in which a portion of the water to be softened is saturated with lime,

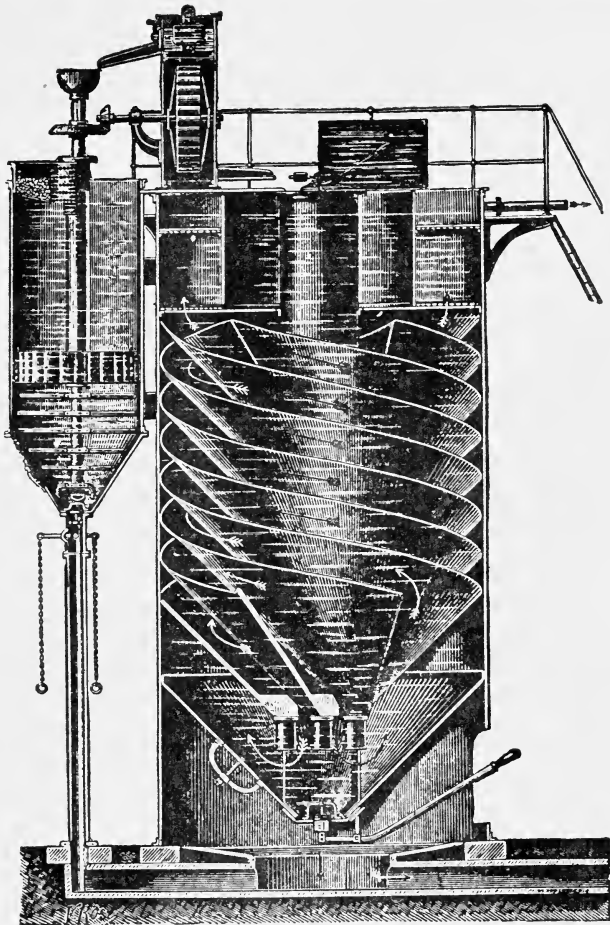

FIG. 71.—Section of the Desrumaux Water Softener. The Saturator is shown on the left, with the Water-wheel Stirrer. The Water Wheel at the top of the Main Chamber will be noted, also the Spiral Baffle Plates.

a revolving wheel ensuring that the mixing is complete. The remainder of the water to be softened passes over the water wheel,

the power delivered to the wheel being employed to drive the stirrer in the saturator. The water from the saturator flows into the centre of the main chamber, after it has been thoroughly saturated, and there meets the water to be softened and a certain quantity of a solution of soda, from a rectangular tank above. The water and the reagents pass through a central chamber or tube, to the bottom of the main tank, where precipitation takes place as usual, the water then rises to the top, around spiral baffle plates, which arrest any precipitate that has not been left at the bottom, the matter so caught finding its way to the bottom of the main tank. At the top of the main tank the water passes through a filter in the usual way.

### **The Arthur Koppel Water Softener**

In this apparatus the precipitating tank may be either cylindrical, rectangular, or any convenient shape. The chemical tank above the precipitating tank may also be cylindrical or rectangular. One of the special features of the apparatus is the arrangement for delivering the required quantity of each reagent to the water to be softened. It is accomplished by bucket conveyors. There is a tank for each of the reagents, and a bucket conveyor dipping into each, and both conveyors are worked by oscillating apparatus. The oscillating vessel is on somewhat similar lines to some of those that have been already described. It has two compartments, and the water that is to be softened flows into one of them, tips it over when full, allowing the water that has been poured into it to pass down to the mixing chamber, while the other half of the apparatus comes under the water pipe. The oscillation of the tipples is made to work the elevators bringing the reagents by means of a ratchet wheel and pawl. The quantity of the reagent carried upwards by the bucket of the conveyor, is tipped over at the top into a small chamber, from which it flows down through a pipe into the mixing chamber. There is a novel form of steam heating apparatus in the chamber into which the water is tipped from the oscillator, consisting of a number of plates over which the water flows, it being arranged that the water is obliged to flow over the length of each plate in succession, and the plates are heated by a steam jet passing up from an exhaust steam pipe, the steam passing up over the under surfaces of the plates, from plate to plate, in the opposite direction to that in which the water is flowing, the water thus being heated as it passes over them. From the heating chamber the water passes down through a pipe into the mixing chamber, where it is further heated by live steam, and agitated by a blast of air. The complete lower chamber is divided into three chambers, the division being in the form of an inverted Y; and the water flows down round

the ends of the division plates, and then up through the filters and out to the feed pipe, the foreign matters depositing at the different points, and finally settling down to the bottom of the tank, and being removed by opening a valve at the bottom.

### Harris-Anderson Water Softener

In the Harris-Anderson apparatus, carbonate of soda and lime are sometimes used in conjunction, as in other apparatus, and sometimes lime is used alone. In the apparatus employing carbonate of soda, the mixing of the reagents is carried out by special apparatus, quite different to any of those that have been described. 0.5 per cent. by volume of the reagents are always supplied to the water to be softened, no matter what its composition may be, and for this purpose a special apparatus, known as a distributor, is employed, in which two compartments receive  $\frac{1}{2}$  per cent. of the total flow, and two others 49 $\frac{1}{2}$  per cent. The proportion of the water received in the  $\frac{1}{2}$  per cent. compartments, is taken to an apparatus called the solutioner, consisting of four cylinders, one inside the other, with a wire gauze cage fixed in the top of the inner cylinder. The cylinders are so arranged that the water to be softened circulates in the annular spaces between them, taking up the reagent in the wire gauze cylinder on its way, and they are further arranged so that their position can be altered at will, so that the speed of flow can be changed. Following the distributor and the apparatus for mixing the solutions of the reagents, comes that for mixing the water with the solutions of the reagents. For this purpose three pairs of concentric tubes are provided, one for each half of the water and the solution of reagents, and the third for the two halves of the water and reagents together. One half of the water and the one half of the prepared solution of reagents is passed down the centre of one set of tubes, and up through the annular space between them, the two streams from the two halves then join, and pass down the central tube of the third set, and up the annular space between the two. It is claimed that by this system of concentric tubes, complete mixing of the solution of the reagents in the first place, and complete mixing of the water with the solutions in the second place, is carried out very thoroughly.

After the mixing tubes there are treatment vessels, consisting of tanks of various forms, according to convenience, through which the liquid is obliged to pass in a circuitous course, by the aid of baffles provided for the purpose, the usual precipitation taking place in this vessel. From the treatment vessel the softened water passes successively through two sets of wood-wool filters. It is claimed that the primary filter, as it is called, through which the water first passes,

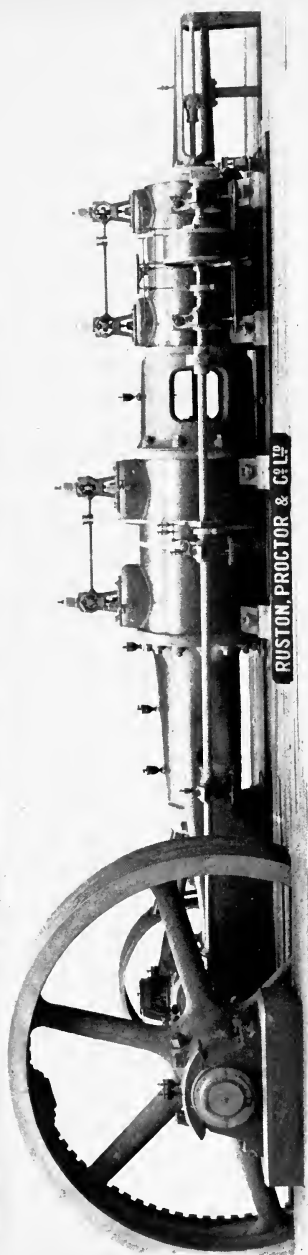

PLATE 11A.—Ruston & Proctor's Tandem Compound Engine, with Trip Valve Gear, and "downstairs" Condenser, the Air Pump being worked by the Rod shown, connected to the Tail Shaft.



PLATE 11B.—Another View, from left rear, of the Engine shown in Plate 11A.



PLATE 11C.—Right rear View of Engine shown in Plate 11A. [To face p. 192.]



clarifies it thoroughly, but a second filter is added to make sure. The filters require cleaning, the primary once every 24 hours, and the secondaries twice a week. The fact that cleaning is required is known by the increased pressure required to make the water pass through the filter. Fig. 72 shows diagrammatically the course of the water to be purified, and Fig. 73 is a drawing of the apparatus, showing the different vessels through which the water passes.

When lime alone is used, one compartment of the distributor is arranged with a movable wall, enabling the quantity dealt with to be varied at will. The water from this compartment of the distributor is carried to the bottom of a tank, of moderate depth, charged with a mixture of slaked lime and water, kept in motion by a blower of air. The lime is slaked in a separate vessel, and run into the lime tank as milk of lime, the spent lime having been previously removed. The remainder of the arrangement is similar to that already described.

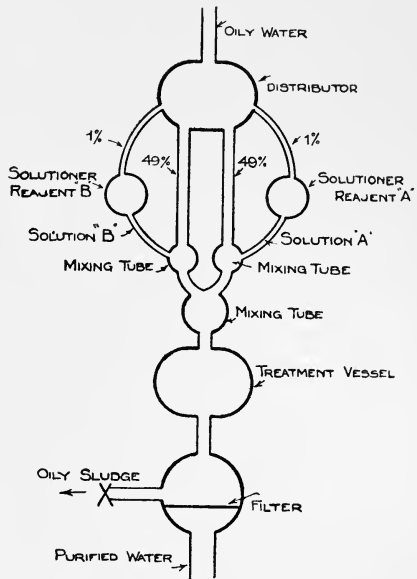

FIG. 72.—Diagram showing the course of the Water to be purified in the Harris-Anderson Apparatus.

## Removing the Oil from the Water

Removing the oil from the water is a very much more difficult matter. It is partly accomplished by the use of oil separators, of which descriptions are given below, the oil separated being filtered and used again.

### Oil Separators

There are several patterns of oil separators, all of which are constructed on very much the same lines. They usually consist of a cylindrical tank, into which the steam is allowed to enter on its way to the condenser. Within the tank the steam is usually given a more or less circuitous and whirling motion, and is made to pass

through perforated baffle plates, each of which arrests some of the oil as the steam passes through, and it is claimed that all oil is removed by the process.

Fletcher's oil separator, made by Messrs. Royle, consists of the usual cylindrical vessel, with an inlet for the steam on the left, and

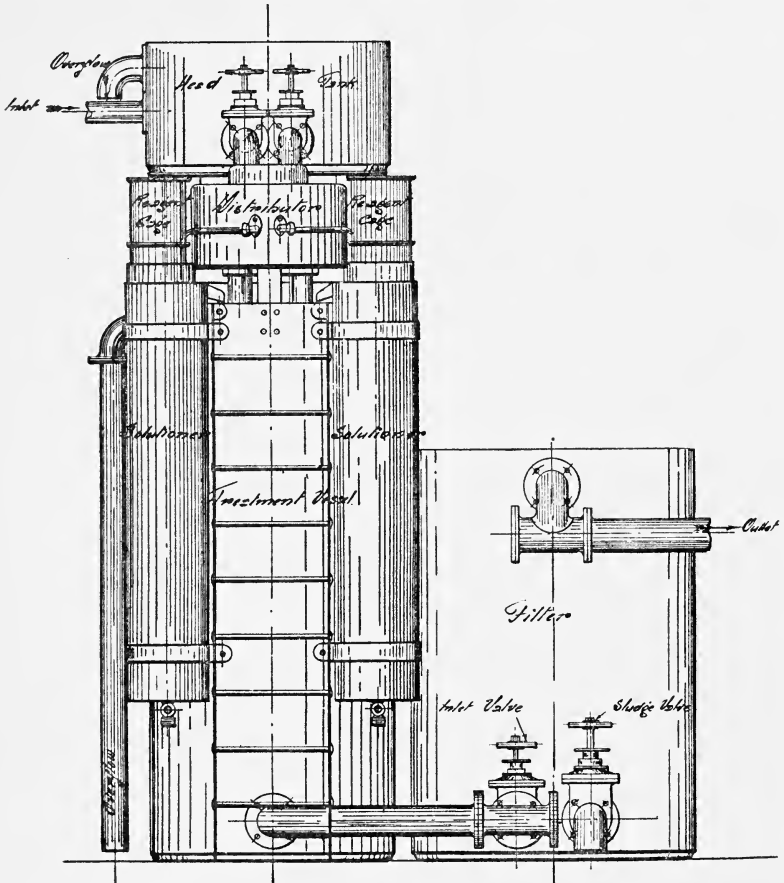

FIG. 73.—Drawing showing the Harris-Anderson Water-purifying Apparatus.

an outlet on the right. The space is divided by a horizontal tube-plate just below the line of the main steam pipes, and again by a vertical division extending from the top to within a short distance of the tube plate, and by another vertical division between the tube plate and the top of the apparatus. There are tubes passing down



from nearly the top of the apparatus through the tube plate into the tank below, which is nearly on the bottom of the apparatus. In the right-hand portion there are also tubes held by the tube plate, leaving a free space above and below them. The steam entering is accompanied, it is found in the inventor's experience, by oil and water, these keeping to the lower portion of the entrance pipe, and being carried over into a tube on the left of the apparatus, which carries them to the bottom. This, it is claimed, is a preliminary separation of the oil and steam, the remainder of the apparatus having only to deal with the oil carried over *in* the steam. The steam passes from the inlet down through the tubes in the left-hand portion into the water in the tank, where, it is claimed, the steam is further cleansed from oil. The steam then bubbles up through the water, passes up on the outside of the tubes through which it descended, over the top of the partition between the two compartments, down over the outside of the tubes in the right-hand compartments, up through the tubes in that compartment, and thence to the outlet. It is claimed that the steam spaces within the apparatus being large compared with the steam pipe, the steam is not throttled in any way.

### Cochrane Vacuum Oil Separator

In this apparatus, which is made by the Erith Engineering Co., the oil is caught in its passage through a vessel, whose area is large in proportion to the pipe that brings the steam to it, by a baffle plate occupying the centre of the area, and fitted with ribs, a sufficient annular space being provided all round the baffle plate to allow of the passage of the steam without throttling. The apparatus is made both for fixing in vertical and horizontal pipes, and the idea in its construction is that the heavier oil globules will be caught by the central baffle plate, while the lighter steam will pass by the annular passage at the side.

### Reid Oil Separators

In the Reid oil separator, sectional drawings of which are shown, in Fig. 74, there is the usual iron cylinder, the steam entering through the central pipe, which is at first slightly contracted, and then opens out into a bell mouth. The depositing chamber is at the bottom of the cylinder, and there is a battery of corrugated iron plates, arranged radially, suspended vertically between two dished plates, occupying an annular space above the depositing chamber. The

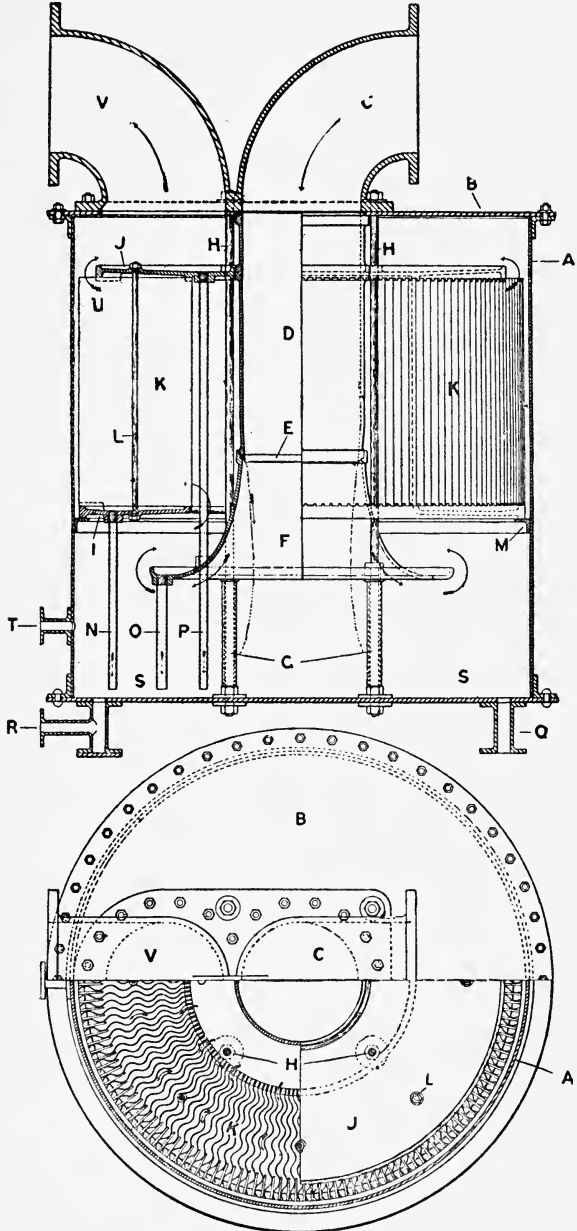

FIG. 74.—Vertical and Transverse Section of Reid's Oil Separator. The Steam enters at C, passes through D to F, and then up between the corrugated plates K.

steam passes up between the corrugated plates and through an outlet pipe. The action of the apparatus is as follows: The velocity of the steam being reduced by the bell-mouthed enlargement of the entry pipe, while the velocity of the oil or grease particles is not so much affected, the latter are thrown forward on to the bottom of a depositing chamber. This cleanses the steam to a large extent from oil particles, it is claimed, and the remaining particles are removed by the passage of the steam over the surfaces of the corrugated plates. The inventor claims that the action of the corrugated plates upon the steam is similar to that of the scrubber in a gas-making plant. The oil particles are caught by the plates and run down into the depositing chamber, from which they are drained off in the usual way.

### A Steam Exhaust Head and Oil Catcher

It is sometimes necessary to provide some means of preventing the exhaust steam, where engines do not work with condensers, and which would usually be delivered in the open air, from being thrown down on the roofs of adjacent buildings, accompanied by the oil that has been carried over from the engine cylinders, and also to reduce the noise of the exhaust steam at each stroke of the engines, that is sometimes objectionable. There are various forms of exhaust heads. One is shown in section in Fig. 75, made by Messrs. Holden and Brooke, the course of the steam being shown by the arrows. It will be seen that the steam enters by the inlet pipe at the bottom, passes round the outside of the cup-shaped vessel in the centre, and out through the outlet at the top, the oil and condensed steam being deposited upon the different surfaces over which it passes.

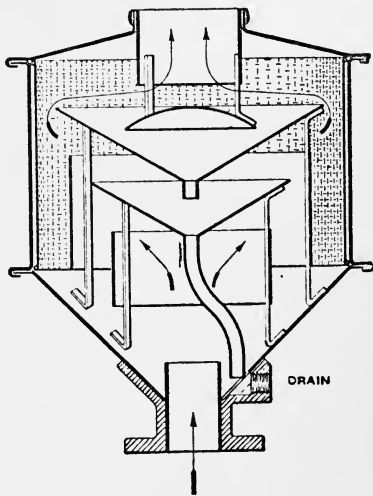

FIG. 75.—Messrs. Holden & Brooke's Exhaust Head for preventing fine particles of Oil being carried out to the neighbourhood.

### Special Apparatus for Removing Oil

There are two kinds of apparatus at present on the market for removing the oil from exhaust steam, the best known of which is the

Harris Anderson. The Harris Anderson apparatus for removing oil is very similar in every respect to that for softening water, except that the reagents employed are carbonate of soda and sulphate of alumina. The inventor of the Harris Anderson apparatus states that he has found, by careful microscopic examination of condensed water that has been subjected to the usual separation treatment by gravity, that globules of oil are floating about in the water, and that even the filtration by the very closest filtering material does not remove them. After oily water has been treated, the inventor finds that the globules

of oil are drawn together. The inventor claims that, by the addition of his reagents, and by the working of his process, the oil globules are caused to coalesce, and can then be dealt with by the filters in the ordinary way. The working of the apparatus is practically the same as that of the water softener.

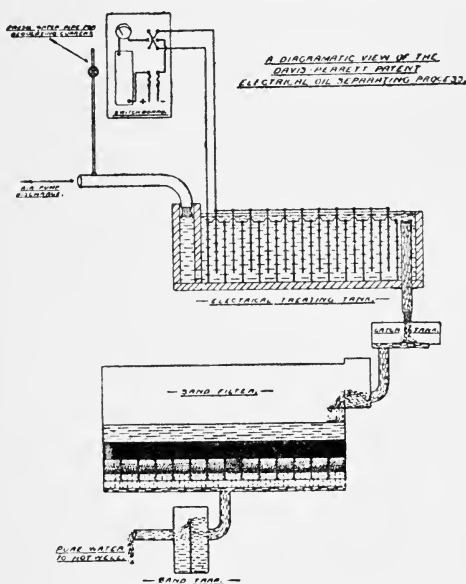

FIG. 76.—Diagram of Davis-Perrett's Electrical Emulsifier. The Water to be purified is passed through the Electrolytic Tanks and then through the Filter.

principal portion consists of a number of wooden tanks, similar to those employed for electro-plating, in which a number of iron or other metallic plates are suspended, and the water to be purified is caused to pass through the tanks in succession, being given a circuitous path, so that it is obliged to pass over a large area of the plates. The electric current splits up the water and the oily substances mixed with it, by the well-known property of electrolysis, and a flocculent precipitate is formed from the components, combined with the oxides of the metals over which the water has passed, the precipitate being easily removed afterwards by a filter.

## Davis-Perrett's Electrical Emulsifier

In this apparatus completely new ground has been taken, the oil being separated from the water by the aid of electricity. In the apparatus, a diagram of the connections of which is shown in Fig. 76, the

There is the usual preliminary settling tank provided with the Davis-Perrett apparatus, in which a certain quantity of the grosser oil particles separates out by gravitation and is recovered, the remainder of the water then flowing to the electrolytic tanks. After the electrolytic tank, the treated water flows first into a catch tank, where a certain further precipitation takes place, and then to a sand filter. Other forms of filter are also provided where it is necessary, and the water then flows from the bottom of the filter, through a sand trap, as shown in the diagram, to the hot well. The makers prefer a sand filter, as it is easily cleaned by removing the upper layer of sand. The plates in the electrolytic tank are cleaned automatically by reversing the direction of the current through them. It will be understood that the electrolytic action takes place principally upon one set of the plates, and when these become foul the reversal of the current looses the scum upon them, causing it to float to the surface, where it can be removed by skimming in the usual way. The following are the spaces occupied by apparatus for treating different quantities :—

For 1000 gallons per hour	100 square feet floor space	× 15 feet to 20 feet high					
" 2000	"  "  "	120	"  "	"  "	"  "	"  "	"  "
" 4000	"  "	225	"  "	"  "	"  "	"  "	"  "
" 8000	"  "	290	"  "	"  "	"  "	"  "	"  "

## Superheating the Steam

Superheaters perhaps belong properly to the domain of steam engines, but they are usually combined directly with boilers, and therefore will be described here, and their use discussed. It was explained in the first chapter that when steam is formed from the water in a boiler, it carries over with it into the steam space minute particles of water. The water so carried forward is sometimes in the form of vapour, sometimes simply in the form of finely divided water, but in all cases has absorbed a very much smaller quantity of heat than the steam by which it is held in suspension. The water particles and the vapour particles are held in suspension in the steam, very much as dust is held in the air, and as the mechanical particles mentioned are held in water. When the steam containing these particles of water enters a steam cylinder, the temperature of the walls of which are lower than that of the steam itself, if the engine is working expansively, as will be explained, the temperature of the whole of the steam being lowered, its ability to hold the water in suspension is lowered, and the particles of water are deposited upon the walls of the cylinder, taking heat from them at a later portion of the stroke, to the disadvantage of the efficiency of the engine.

To avoid this, the steam after it has left the steam space in the

boiler, and therefore when it is out of contact with the water from which it was formed, is exposed to further heating, either from the hot gases of the boiler furnace itself, or from the hot gases of a separate furnace arranged for the purpose. In either case the steam is made to pass through a number of small pipes, between which the steam is split up, the outside of the pipes being exposed to the heat of the hot gases, and the result is the steam is dried. That is to say, the particles of water and watery vapour that are held in suspension, are converted into steam at the same temperature as that in which they are held, and the steam passes on to the engine free from the presence of any watery vapour, if the superheating, as it is called, has been properly done.

The amount of superheat arranged in different cases varies from  $100^{\circ}$  F. to  $300^{\circ}$  F.,  $150^{\circ}$  F. being a common figure, and it is understood that the whole of the steam passing through the superheater has its temperature raised by that number of degrees, the water and watery vapour carried in suspension being raised to steam at the final temperature. The quantity of heat required to perform the operation of superheating evidently depends upon the quantity of water and watery vapour present. This has been determined by the principal boiler makers, and their superheaters are constructed to furnish the largest quantity of heat that may be required, under the worst conditions of moisture present. It should be mentioned incidentally that watery vapour is more readily carried over with the steam when boilers are forced, and that it is claimed by advocates of Lancashire and similar boilers that water-tube boilers, though they will raise steam very readily, are subject to this action of priming when the boilers are forced. The quantity of watery vapour present in the steam is estimated by means of an apparatus designed for the purpose, called a calorimeter, the operation of which consists either in separating the water carried by the steam from it, in a sensitive apparatus arranged for the purpose; or in estimating the moisture present in a measured quantity of steam by forcing it through a small passage, leading from a higher to a lower pressure, and measuring the degrees of superheat given to the steam. When moisture is present the superheating will be less by the heat absorbed by the moisture.

## Forms of Superheating Apparatus

**The Babcock Wilcox.**—The Babcock Wilcox superheater, which is shown in Plate 5A, in connection with the boiler, consists of a number of U-tubes fixed horizontally, immediately below the steam drum. As will be seen, there is a baffle below the lower

portion of the superheater, and it is exposed to the full force of the hot gases rising directly from the furnace.

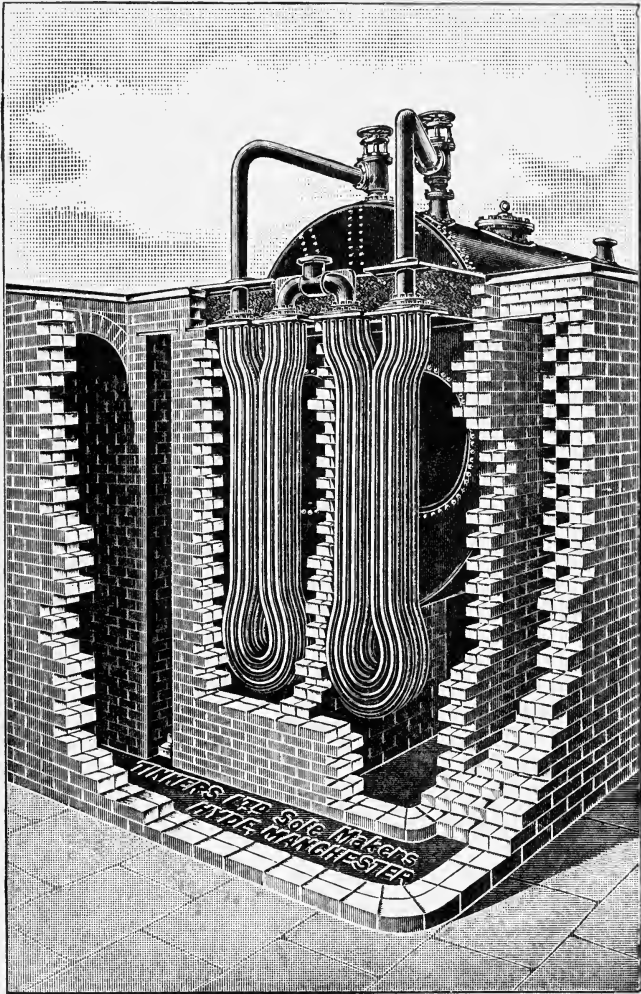

FIG. 77.—Tinker's Superheater, as fitted to a Lancashire Boiler. The Steam to be heated passes through the Coils of Pipes shown, the Pipes being fixed in the Path of the Hot Gases from the Boiler Flues to the Chimney.

**The Stirling Superheater.**—The Stirling superheater is shown in Fig. 12, and, as will be seen, consists of a number of tubes, fixed

between two smaller drums, the tubes lying in the space between the foremost and second bank of the boiler tubes, so that they are subject to the hot gases in the earlier portion of their travel.

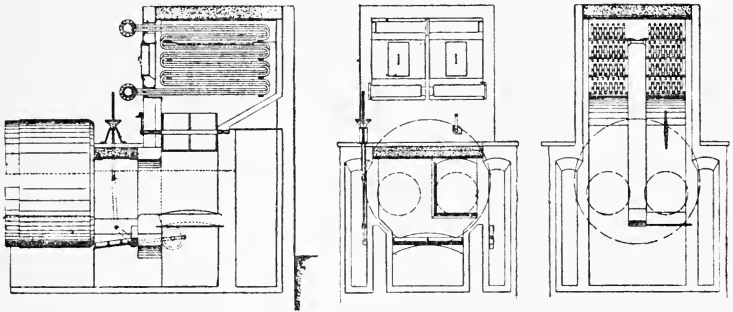

FIG. 78.—Schmidt's Superheater arranged for heating by Boiler Flue Gases. It is shown at the back of a Lancashire Boiler.

**The Nesdrum Superheater.**—The Nesdrum superheater consists of a number of tubes of a zigzag form, fixed between the steam

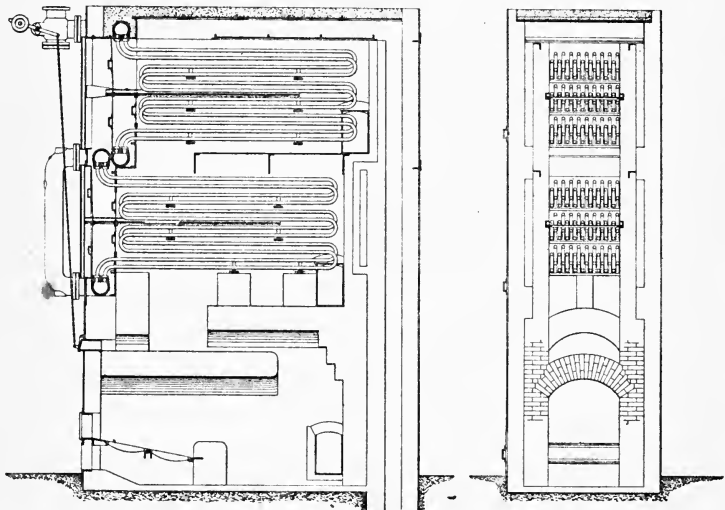

FIG. 79.—Longitudinal and Transverse Section of Schmidt's Superheater, arranged for direct firing. The Furnace for the Superheater is shown below.

drum and the exit steam pipe, the tubes lying in the rear space between the vertical tubes and the next bank in front of them.



**The Sinclair Superheater.**—The Sinclair superheater consists of **U**-tubes, fixed vertically in a space provided for them at the back of the boiler, on the way to the chimney, by means of a baffle in front of the rear wall. They receive heat from the hot gases after they have done their work upon the whole of the boiler tubes.

**The Galloway Superheater.**—The Galloway superheater is arranged to be fixed in the downtake at the back of Galloway and other Lancashire boilers, so that it is subjected to the hot gases immediately after they leave the main boiler flues. It consists of a number of **U**-tubes, connected to a top plate, to which the steam is led from the boiler, and from which it is taken after having passed through the tubes.

**The Tinker Superheater.**—The Tinker superheater, which is shown in Fig. 77, consists of two banks of tubes, approximately of **U** form, fixed vertically in the downtake of Lancashire boilers, the steam passing through the two sets in succession, and the superheater pipes being subjected to the hot gases in a similar manner to the Galloway. The Schmidt superheater, made by Easton and Co., is arranged for heating from the flue gases, as shown in Fig. 78, or for separate firing, as shown in Fig. 79. It consists of grids of pipes fixed horizontally, the flue gases passing up between the pipes.

## Steam Separators

The steam separator is another auxiliary apparatus that has been introduced for the purpose of drying the steam, when superheaters are not employed, and also for removing any watery vapour that may be present in other positions, and preventing it going into the steam engine. They are all arranged on something the same lines, the principle of which is, the bringing into play the force of gravity, acting upon the greater weight of the watery particles, and causing them to be deposited. Steam separators are very similar in many respects to some of the oil separators that have been described. They consist usually of a vessel, into which the steam is carried, and in which it is given a more or less circuitous, and sometimes a whirling path, and in which there are a certain number of baffle plates, these latter arresting the watery particles while the steam passes on, the water draining to the bottom of the vessel and being removed by a cock provided for it.

**The Marriot Steam Separator.**—In this apparatus, which is intended for separating oil, water, dirt, and grease from the steam, there is the usual vertical cylinder, surmounted by a cylindrical casting, with inlet and exit pipes for the steam. In the central portion of the upper vessel, and the chamber below, a number of

iron rods of various sections are fixed vertically, and the idea of the inventor is, that the steam passing through the apparatus will be diverted by the outer edges of the rods, and that a cushion of steam will be left in the concave spaces into which water, oil, and other impurities will be thrown, the steam escaping past them to the outlet, and the water and oil, etc., trickling down to the bottom of the vessel, where they are run off in the usual way. Fig. 80 shows the Sims

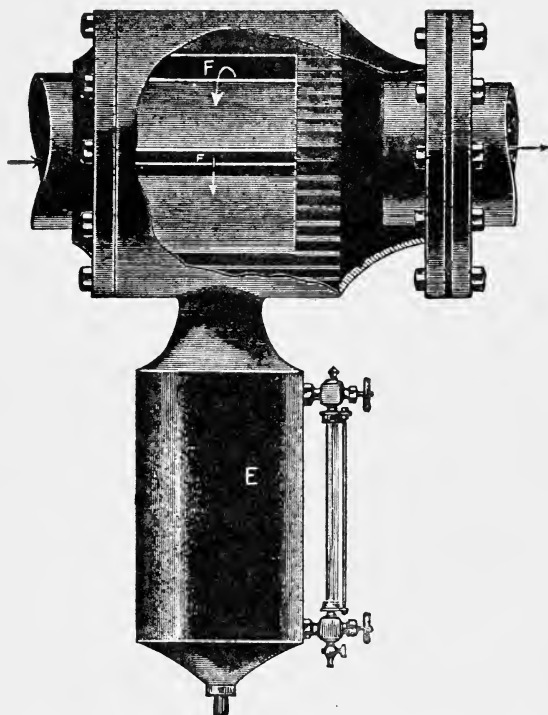

FIG. 80.—The Sims Steam Separator, for fixing in a Horizontal Pipe. F is a Deflector arranged for the Steam to be thrown against, and E is a Well into which the separated Water drains.

steam separator, an American apparatus. The steam is given a whirling motion inside the apparatus, and is thrown up against the deflectors shown, the water being left there, and draining down into the well below.

## Evaporators

The evaporator is another auxiliary apparatus, employed principally on board ship, where it is of such great importance that the

feed water shall be absolutely pure, to make up the waste. In steam engine practice, where condensers are employed, the water from which the steam was generated in the boiler again becomes water in the condenser, as explained later, and is used in many cases, nearly always on board ship, for feeding the boiler. But there is always a certain small loss between the steam which leaves the boiler and the water which re-enters it after having done its work in the engine, and been condensed. There is nearly always a certain amount of leakage of steam at different parts of the engine system. There is also a certain amount of loss by condensation, the water so formed being drained off by steam traps provided for the purpose, and being lost so far as the steam system is concerned. Hence a certain quantity of fresh water is required to make up the loss, and this is provided in modern steamships by the aid of an evaporator. Evaporators are of various forms, but all conform to certain conditions. In all of them there are two parts to the apparatus, one in which sea water, or the water that is to be employed for making up, is caused to evaporate at very low pressure, and the other in which the vapour so formed is recondensed into water and carried off to the hot well or to the boiler.

High-pressure steam is employed as the heating agent in that portion in which the water is evaporated. In one such apparatus, made by Messrs. Royle, steam is passed through tubes, while the water surrounds them, and is formed into vapour. The upper portion of the apparatus is a condenser, to which the vapour formed in the evaporator rises, and where it passes through tubes, around which cold water is circulated, the vapour being then formed into distilled water.

The apparatus is also employed for distilling water for drinking, etc., on board ship, if the supply gives out. Plate 10A shows an evaporator made by the Central Engineering Co., Hartlepool. Fig. 81 is a sectional diagram of Weir's vertical type of evaporation.

## Apparatus for Testing the Flue Gases in the Chimney

In recent years sources of economy in steam and coal have been considerably multiplied, but it has been felt that some means is necessary for checking the results. Thus, good boilers, mechanical stokers, good draught, and everything that is necessary to economy may be provided, and yet from certain causes the results may not be as economical as would be hoped, and every means of testing the results, and every means of testing from point to point of the steam system, is of value. In modern plant the coal is all weighed into

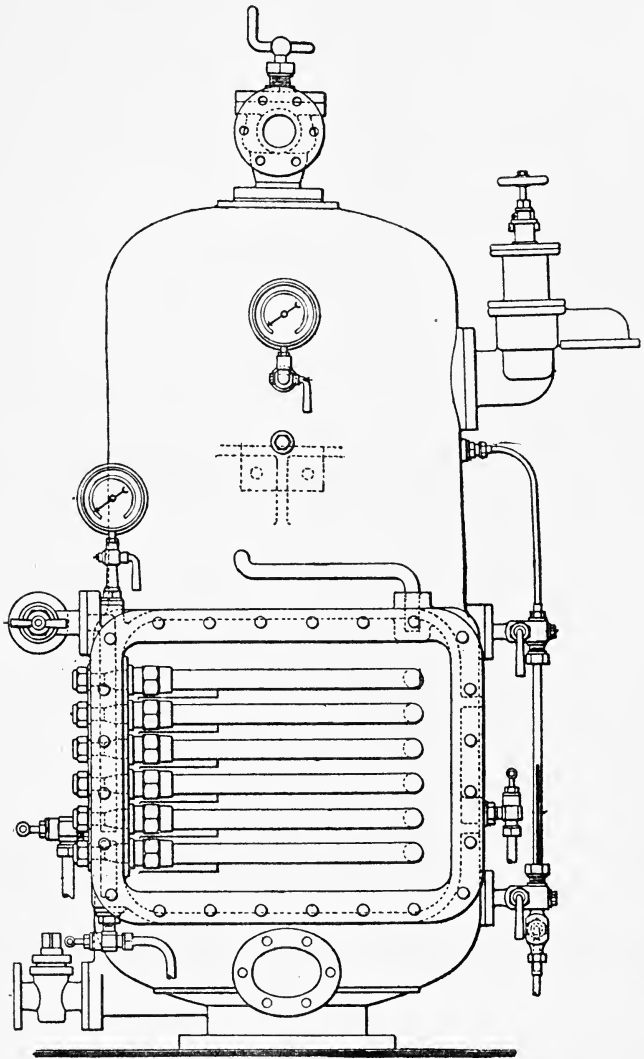

FIG. 81.—Sectional Drawing of Weir's Vertical Evaporator, with the lower portion open. The Water is evaporated in the lower portion and recondensed in the upper portion.

the hopper of the boiler furnace, the water is usually measured, so that a check is kept upon the consumption, and, in addition, the apparatus to be described has been designed for testing the fuel gases in the chimney. It was explained in the first chapter that a certain quantity of air must be supplied for each pound of fuel that is to be burned, because that quantity of air—12 lbs. at average temperatures—will furnish the necessary quantity of oxygen to completely oxidize the pound of carbon to carbonic acid. It follows from this that if exactly the right quantity of air is furnished, and if the whole of the oxygen combines with the whole of the carbon, assuming that only carbon is present, the resultant gases must consist of nitrogen and carbonic acid, in the same proportion as the air consisted of nitrogen and oxygen, or the carbonic acid present must be 21 per cent. of the resultant gases. It was also pointed out that it is not possible to work with the exact quantity of air that will furnish the correct quantity of oxygen. More frequently double the quantity of air is provided, and, in addition, coal is not all carbon. It often contains some uncombined hydrogen; and it also contains other substances, known generically as ash. It is found, however, that a test of the fuel gases, to show what percentage of carbonic acid is present, is also an approximate test of

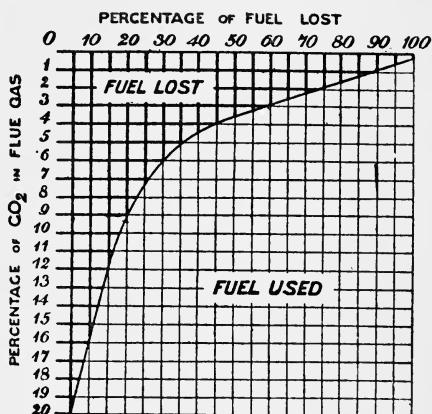

FIG. 82.—Showing the percentage of Fuel lost, with different percentages of CO<sub>2</sub> in the Flue Gases.

the way in which combustion is going on in the boiler furnace. With all the carbon combined with oxygen, and with no surplus air, and with no other substances present, the fuel gases should show 21 per cent. of carbonic acid. At the other end of the scale, if none of the carbon combines with oxygen no carbonic acid will be formed. Obviously, between these two there are various degrees, and in the curve shown in Fig. 82 the various possible percentages of CO<sub>2</sub> present in the fuel gases have been plotted, and with them the percentages of loss of fuel. The ordinates represent percentages of CO<sub>2</sub>, and the abscissae represent percentages of fuel lost. At the origin no fuel is lost, and at the end of the curve of course the whole of the fuel is lost. It will be noticed that the curve, which is parabolic, rises very steeply for a certain portion, and then turns

rather rapidly, the meaning of this being that the percentages of loss of fuel increase very slowly with decreased percentages of carbonic acid, down to 12 per cent. of  $\text{CO}_2$ , after which the losses increase rapidly. It is stated that a loss of 12 per cent. of fuel, corresponding to a percentage of 15 per cent. of  $\text{CO}_2$ , is the best result obtainable in practice, while results such as from 7 to 8 per cent. of  $\text{CO}_2$ , meaning losses of from 22 to 25 per cent. of fuel, are very common.

### The Sarco Automatic $\text{CO}_2$ Recorder

The Sarco apparatus is intended to note on a chart provided for the purpose, the percentage of  $\text{CO}_2$  in the fuel gases from hour to hour, so that the actual working of the boilers, and the attention the furnaces have received, can be checked from time to time.

There are two forms of the apparatus, one worked by water and the other by the fuel gases themselves. Both are arranged to furnish a definite quantity of the fuel gases at certain definite intervals, as may be arranged by the engineer. In both there is a pipe connecting the end of the flue, or the beginning of the chimney, at any convenient point, with the apparatus, the connection being made by a piece of flexible gas tube, and there is practically a pump worked either by the fuel gases or by water, drawing a certain quantity of the gases passing at the moment into the apparatus, the connection to the flue being closed as soon as the required quantity has been drawn off, and automatically reopened as soon as measurement has taken place. The measurement, as explained, is of the percentage of  $\text{CO}_2$  in the flue gases, and it is accomplished by the absorption of the  $\text{CO}_2$  contained in the sample of the gases drawn off at each stroke of the pump, the amount absorbed being measured on a scale, and at the same time a pencil marking the quantity on a chart, in the form of a vertical line, as shown. The pump in which flue gases are employed is very similar to one of the forms of pump used for compressing illuminating gas for use in high-pressure burners. It consists of a cylinder with a second cylinder fixed concentrically inside it, the cylinder and the annular space being filled with water to a certain height, and a bell, similar to that employed in gasometers but very much smaller, dipping into the water, forming the usual water seal. From the top of the bell a rope passes over a pulley above, and is secured to a counter-weight, the counter-weight also being attached on its under side to a bottle filled with glycerine and water, and forming a part of the testing apparatus. A tube is connected to the inside of the bell, and by means of a pipe, forming part of it, to the flue gases, the connection being made by a flexible tube. The pressure in the flue being less, it will be remembered,

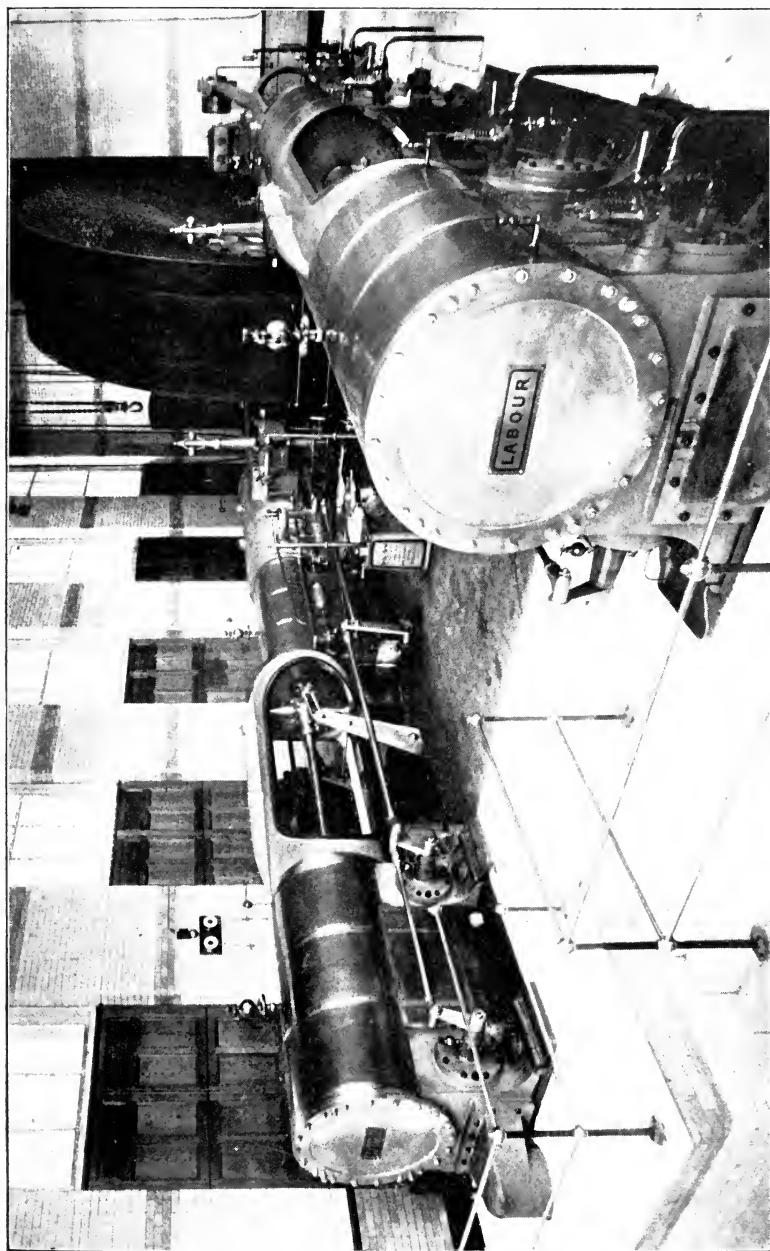

PLATE 12.—Horizontal Triple Expansion Lancashire Mill Engine, with “Wheelock” Valves, made by Messrs. Daniel & Adamson. [To face p. 208.





than the atmosphere outside, when connection is made between the inside of the bell and the flue, the air in the bell is drawn out, the bell then sinking in the containing vessel,

and drawing down the counter-balance weight and revolving the pulley above. The pulley carries two studs, which are alternately brought into contact with a lever just below the pulley, which controls a valve, closing and opening the connection between the flue and the bell.

When the bell has fallen to a certain depth, connection with the flue is shut off, and air is admitted to the bell, causing it to rise, the pulley revolving in the opposite direction, bringing the other stud into contact with the lever, throwing open the valve leading to the flue gases, shutting off the atmosphere, and opening a passage to the flue. The bell now falls again, and so on. On the right of the apparatus, as shown in Fig. 83, are two smaller pumps, worked by one rope, passing over a smaller pulley carried on the same axle as

the pulley moved by the bell, and also over the two guide pulleys, as shown. The two smaller pumps are arranged on the same lines as the larger one, but they have oil seals instead of water seals, and

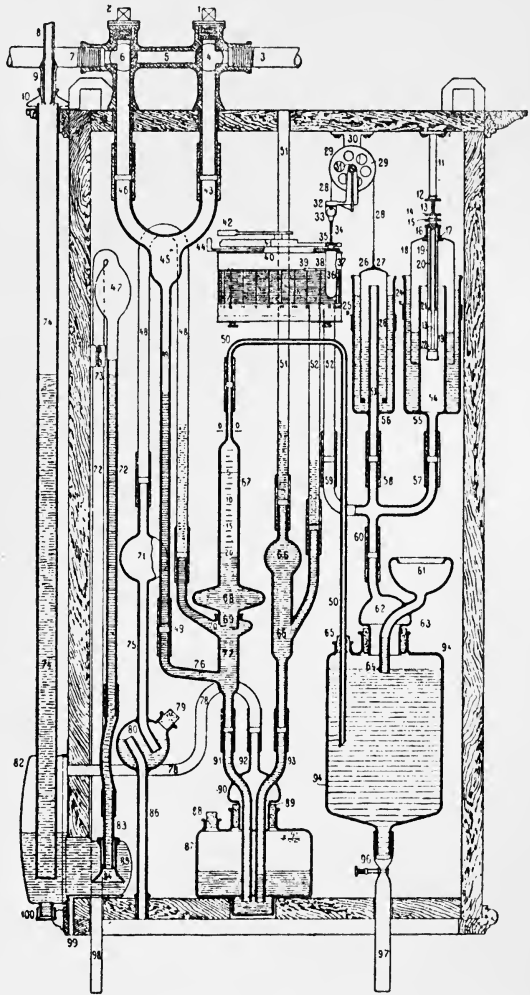

FIG. 83.—Sectional Elevation of "Sarco" Flue Gas Testing Apparatus, made by Messrs. Sanders, Rehder & Co.

their office is to pump gas from the flue into the measuring apparatus shown in the diagram in Fig. 83. The measuring apparatus consists of a system of tubes, in connection with the lower part of a bottle containing glycerine and water that is carried by the counter-balance weight. As the pump rises and falls, and the small pumps rise and fall, the gas is pumped alternately into these tubes, from which it passes over into a conical vessel filled with caustic potash.

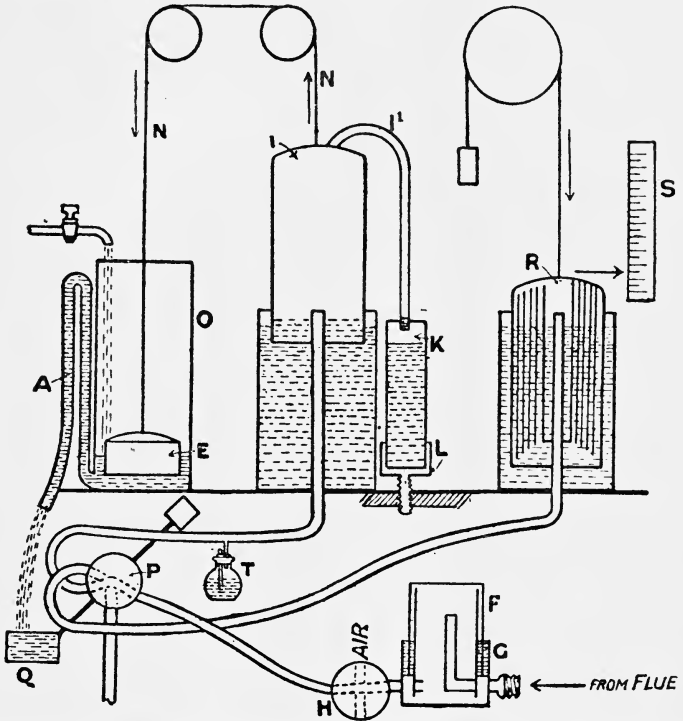

FIG. 84.—Diagram of the Simmance and Abady Flue Gas-testing Apparatus.

Caustic potash has the property of absorbing  $\text{CO}_2$ , and evidently the quantity of gas present will be less by the amount of  $\text{CO}_2$  absorbed. The tubes mentioned, and another, are arranged so that a definite quantity of the gases—100 cubic centimetres—are taken for measurement at each stroke of the pump, and the quantity of  $\text{CO}_2$  present is shown by the position of a small tube, which works a lever, at one end of which is a counter-balance, and at the other end a rod carrying a pencil, which moves up and down over the chart. The chart

is revolved in the usual way by clock-work, and the indications are merely straight lines, whose edges form a curve.

In the Sarco apparatus, known as type B, which is the form shown in Fig. 83, the arrangement is very similar, but rather more compact, and the pump is worked by water. Clean water is required, though, providing it is clean, any kind of water will do; and from 2 to 5 gallons per hour are required to drive the machine, according to the speed at which it is operated. The water must have a head of about 2 feet in order to operate the apparatus, and may be used over and over again.

### The Simmance and Abady CO<sub>2</sub> Recorder

In this apparatus, which is made by Messrs. Alexander Wright & Co., a diagram of which is shown in Fig. 84, the arrangement is very similar in principle, but the motor which pumps the flue gases into the apparatus is always worked by water, and the general arrangement is rather simpler than that of the Sarco. The quantity of flue gas taken from the flues is measured, as in the Sarco apparatus, by filling a vessel of a certain capacity at each stroke of the pump, the working of the apparatus being automatic. The analyzer, as it is termed by the inventors, is different from that in the Sarco. It is shown at R in the figure, and consists of an inverted cylinder,

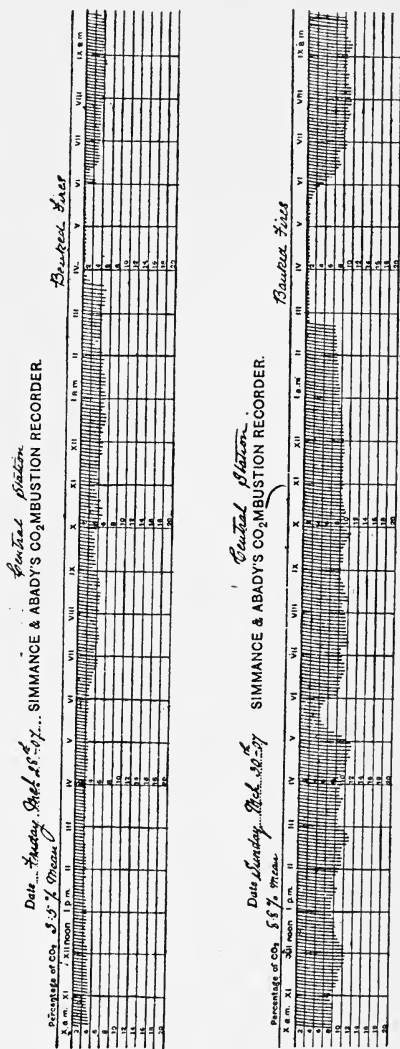

FIG. 85.—Charts taken by Simmance and Abady's Flue Gas-testing Apparatus.

passing into a tank filled with caustic potash, this forming the usual seal, and the bell contains a number of concentric tubes in communication with each other, their surfaces being wetted with the caustic potash solution. The flue gases to be measured are made to pass into the bell, and over the whole of the surfaces of the concentric tubes, and the quantity of  $\text{CO}_2$  absorbed is measured by the amount the bell falls, this being marked on the scale S, shown on the right, and also by a line on the chart, as with the Sarco. Fig. 85 shows two charts taken with the Simmance and Abady apparatus.

### The Orsat Apparatus for Flue Gas Analysis

This apparatus is designed for a more accurate analysis of the flue gases, but it does not give a continuous record, as the others that have been described do. It has three absorbing apparatus, designed to absorb carbonic acid, oxygen, and carbonic oxide, the absorption of these forming a complete analysis of the flue gases. It will be evident that while the apparatus that have been described for giving a continuous record of the carbonic acid present in the flue gases, forms a very valuable check upon the stoking and the working of the boilers generally, it is not so complete as the analysis which gives the full percentage of the other gases present. In the vessel that is to absorb carbonic acid, a solution of caustic potash is held, made by dissolving one part by weight of caustic potash in  $2\frac{1}{2}$  parts of water; in that for oxygen, pyrogallol, made by dissolving one part by weight of pyrogallic acid in two parts of hot water, and three parts of the caustic potash solution made for the absorption of  $\text{CO}_2$ . In the vessel for absorbing carbonic oxide, a solution of cuprous chloride is held, made by dissolving one part by weight of cuprous chloride in seven parts of hydrochloric acid, adding two parts of copper clippings, allowing to stand for twenty-four hours, and then adding three parts of water.

As in the other apparatus described, exactly 100 cubic centimeters of the flue gases are drawn for examination, and are passed into a graduated measuring burette. The measuring burette is surrounded by a vessel of water, so that the temperature of the gas in the burette may be maintained constant. The lower part of the burette is connected to a bottle by a flexible tube, and the gases are drawn into the burette, and thence forced into the absorption vessels in succession, by raising and lowering the bottle, and opening the cocks leading to the different vessels in succession. For rapid work, an aspirator must be employed to draw the gas into the apparatus.

## CHAPTER IV

# THE STEAM ENGINE

## The Reciprocating Steam Engine

THE term "reciprocating" is employed to distinguish what was previously known simply as the steam engine from the turbine, which is also a steam engine, but in which the moving parts do not reciprocate. In the reciprocating engine, as usually understood, there are one or more hollow cylinders, closed at each end, in each of which a solid short cylinder, called the piston, reciprocates, or moves to and fro, the reciprocating motion being communicated from the piston to a rod, fixed in its centre, and projecting through a hole provided for it in one end of the cylinder, and from it usually to a crank shaft. In nearly all forms of reciprocating engines, the steam is admitted alternately on each side of the piston. When admitted on one side of the piston, the piston is forced forward to the other end of the cylinder, carrying the piston-rod with it, and on its arrival there, steam is admitted to the other side, and it is then forced back to the end of the cylinder from which it started, steam being then admitted to the side against which it first pressed, and so on; the to and fro movement continuing as long as the steam is available, the admission valves are working properly, and the work in front of the engine is not greater than the steam can accomplish.

There are a few forms of single-acting, reciprocating engines, a notable example being the Willans, which is described on p. 232. In the old Cornish pumping engines also, which held their own for economy in steam against other forms of engines employed for pumping up till very recently, the steam was admitted only on the under side of the piston, the cylinder being fixed vertically, and the piston being moved upwards by the force of the steam, and being allowed to descend by the force of gravity, aided by the fact that the steam under the piston was condensed, and therefore the pressure below the piston was reduced considerably below that of the atmosphere. As the cylinders were made very large, 6 and 8 feet in diameter, the

effect of the difference between the pressure of the atmosphere and that of the partial vacuum under the piston, was considerable.

In the early forms of steam engines, the steam was admitted to the cylinder without any attempt at what is called working expansively. Practically the action of the steam in those days, and in some old engines even up to the present, is the same as that of water in a reciprocating water engine.

The steam was continuously generated in the boilers, and as long as the "stop valve" leading to the steam chest of the engine was open, the steam merely pushed the piston from one end of the cylinder to the other, and back again. This arrangement holds even yet in some forms of steam pumps, but for the majority of steam engines, expansive working has been introduced, and gradually increased. It will easily be understood that if the steam cylinder is open to the boiler, during the whole of its stroke, it will use a cylinder full of steam, less the space occupied by the piston, at each stroke; while the steam which is ejected from the cylinder on the return stroke, will contain a large portion of the energy with which it entered the cylinder, and unless it is condensed, will offer a considerable resistance to the return of the piston, so that there is a waste of steam, and of coal, from both causes. If in place of allowing the valve controlling the entrance of the steam on each side of the piston to be open during the whole of the stroke, it is closed when the piston has made half the stroke, it will be evident that if the steam is able to complete the stroke of the piston, the work will have been accomplished by the use of only half the quantity of steam, and the pressure resisting the return of the piston, will be considerably decreased. In expansive working, this is what is done. The entrance of the steam to the cylinder is cut off at varying points of the stroke, at  $\frac{3}{4}$ ,  $\frac{1}{2}$ ,  $\frac{3}{8}$ ,  $\frac{1}{4}$ , down to  $\frac{1}{20}$ . The steam is expanded as many times in the passage of the piston to the end of the stroke, as the cut-off is proportionate to the whole of the stroke. Thus, with cut-off at half stroke, the steam is expanded twice, or to twice its volume. With steam cut off at  $\frac{1}{4}$ , it is expanded four times, with cut-off at  $\frac{1}{10}$  it is expanded ten times, and so on. As explained, the remaining work of forcing the piston to the end of its stroke is performed by the expansion of the steam. It will be remembered that with gases—and for this purpose steam may be considered as a gas—the equation  $pv = a$  constant, rules. That is to say, if the volume is increased, the pressure is decreased in the same proportion. Thus, when the steam is cut off at half stroke, and the space occupied by the steam at the end of the stroke is double that occupied when cut off, the pressure at the end of the stroke will be half that at which it was cut off. When the steam is cut off at  $\frac{1}{4}$  stroke, the pressure will be  $\frac{1}{4}$  that figure at the end of the stroke,

and so on. But the working pressure, that operating to force the piston through the remainder of the stroke, after steam is cut off, will, it is evident, be a gradually decreasing one, as the pressure gradually decreases as the volume of the steam increases, and the pressure operating through the remainder of the stroke will be a mean of all the pressures the steam passes through during that portion.

### The Mean Effective Pressure

By the mean effective pressure is meant, the mean of all the pressures through which the steam passes from the moment of its entry into the cylinder, to the end of the stroke. In the case of very late cut-offs, the mean effective pressure will be very nearly that of the pressure at which the steam entered, because that pressure will be effective for a large portion of the stroke, and the final average will not be greatly reduced. On the other hand, with very early cut-offs, the initial pressure of the steam being only present during a very small portion of the stroke, will have only a small effect upon the final average.

In Table XX. the mean effective pressures are given for different steam pressures, and for different cut-offs, from  $\frac{1}{10}$  of a stroke upwards, and from 0 absolute pressure up to 200 lbs. per square inch.

It was pointed out in Chapter I. that considerable advantage was obtained by working with steam at higher pressures than ruled in the early days of steam working, because the quantity of heat required to produce a pound of steam decreased as the pressure increased, and therefore if the whole of the pressure could be effectively employed in the engine, economy must result. When the steam is admitted to the steam cylinder for the full stroke, it is evident that no economy can result from the use of higher pressures, and, in fact, the higher pressure must lead to increased coal consumption; but if the steam can be employed expansively, as by cutting it off at a small portion of the stroke, a considerable economy is obtained. Thus, from the table of Mean Pressures, it will be seen that with a gauge pressure of 105 lbs. per square inch, and with a cut-off at  $\frac{1}{10}$  of the stroke, the mean pressure behind the piston is 39.64 lbs. per square inch, or practically the same as would have been obtained if the steam had been allowed to enter the cylinder during the whole of the stroke with an initial pressure of 40 lbs., while only  $\frac{1}{10}$  part of the steam is employed.

But with the use of higher and higher pressures, a difficulty arises, owing to what is known as cylinder condensation. It will be remembered that the temperature of the steam varies with the pressure. Thus, taking the case just quoted, that of steam at 105 lbs.

TABLE XX.  
TABLE OF MEAN ABSOLUTE STEAM PRESSURES.

Absolute initial pressure in pounds per sq. inch.	Cut-off and ratio of expansion.															
	10	8	6	5	4	3.33	3	2.5	2	1.66	1.5	1.43	1.33	1.25	1.14	1.11
10	3.303	3.848	4.648	5.218	5.965	6.609	6.989	7.664	8.465	9.037	9.366	9.489	9.654	9.784	9.921	9.946
15	4.954	5.774	6.980	7.827	8.947	9.913	10.49	11.49	12.69	13.55	14.05	14.28	14.48	14.67	14.88	14.92
20	6.606	7.697	9.297	10.43	11.93	13.21	13.98	15.32	16.98	18.07	18.73	18.98	19.30	19.56	19.84	19.89
25	8.255	9.620	11.63	13.04	14.91	16.52	17.48	19.16	21.16	22.59	23.41	23.72	24.13	24.46	24.80	24.86
30	9.909	11.54	13.96	15.65	17.90	19.82	20.99	22.99	25.39	27.11	28.10	28.46	28.96	29.35	29.76	29.84
35	11.56	13.47	16.28	18.26	20.87	23.13	24.48	26.82	29.64	31.62	32.78	33.21	33.79	34.24	34.72	34.81
40	13.21	15.39	18.59	20.87	23.86	26.43	27.98	30.65	33.86	36.15	37.43	37.95	38.61	39.13	39.68	39.78
45	14.86	17.32	20.94	23.48	26.84	29.74	31.48	34.48	38.09	40.66	42.14	42.70	43.44	44.02	44.64	44.75
50	16.51	19.24	23.26	26.09	29.82	33.04	34.96	38.32	42.32	45.18	46.82	47.44	48.27	48.92	49.60	49.73
60	19.81	23.09	27.92	31.31	35.79	39.65	41.98	45.98	50.79	54.22	56.20	56.93	57.92	58.70	59.52	59.67
70	23.10	26.94	32.55	36.53	41.75	46.26	48.96	53.65	59.25	63.26	65.56	66.42	67.57	68.48	69.44	69.62
80	26.42	30.79	37.21	41.74	47.72	52.87	55.96	61.31	67.72	72.87	74.86	75.91	77.23	78.27	79.37	79.56
90	29.73	34.64	41.88	46.96	53.68	59.48	62.97	68.97	76.18	81.34	84.28	85.40	86.88	88.05	89.28	89.50
100	33.03	38.48	46.51	52.18	59.65	66.08	69.92	76.64	84.65	90.36	93.64	94.89	96.54	97.84	99.21	99.46
110	36.33	42.34	51.17	57.40	65.61	72.70	76.94	84.30	93.11	99.40	103.0	104.4	106.2	107.6	109.1	109.4
120	39.64	46.18	55.84	62.62	71.58	79.31	83.96	91.96	101.6	108.4	112.4	113.8	115.8	117.4	119.0	119.3
130	42.94	50.08	60.47	67.83	77.54	85.91	90.92	99.63	110.0	117.5	121.7	123.3	125.5	127.2	128.9	129.3
140	46.23	53.88	65.13	73.05	83.51	92.52	97.94	107.3	118.5	126.5	131.1	132.8	135.1	136.9	138.8	139.2
150	49.54	57.73	69.80	78.27	89.47	99.13	104.9	114.9	126.9	135.5	140.5	142.3	144.8	146.7	148.8	149.2
200	66.06	76.97	93.05	104.4	119.3	132.2	139.9	153.3	169.3	180.7	187.3	189.8	193.0	195.6	198.4	198.9



initial pressure, with a cut-off at  $\frac{1}{10}$  of the stroke, the temperature of the steam at that pressure is  $341^{\circ}$  F. Assuming the final pressure of the steam to be about that of the atmosphere, the temperature is only  $212^{\circ}$ . The cylinder walls naturally follow these changes, cooling as the steam expands, and its temperature lowers, warming up again with the fresh steam that enters on the following stroke. Further, it will be remembered, where the engine is working with a condenser, the temperature of the steam in front of the piston may be as low as about  $100^{\circ}$  F., and the cylinder walls and the cylinder cover at that end will follow this temperature, as explained. This means that the cylinder cover and the portion of the cylinder walls at that end, where the fresh steam is to enter, will have been exposed to a temperature of only, say,  $100^{\circ}$ , just previously to the entrance of steam at  $341^{\circ}$ . It has been pointed out, in dealing with the question of superheating, and in discussing the properties of steam in Chapter I., that the steam contains a quantity of vapour, unless it has been superheated, and the effect of the impingement of the steam upon the comparatively cool surfaces in the cylinder into which it enters is, the condensation of this vapour, and also sometimes the lowering of the temperature of the whole body of the steam, certainly of all of it which comes into contact with the metal surfaces of the cylinder, these actions leading to loss of heat, which has to be made up in the furnace of the boiler later on. The vapour which is condensed upon the inner surface of the cylinder is reformed into steam at a later portion of the stroke, when these surfaces have been warmed up at the expense of the entering steam, the conversion of the condensed vapour into steam absorbing a considerable quantity of heat from the cylinder walls and cover, and tending to lower their temperature towards the end of the stroke, in addition to the lowering which takes place from the expansion of the steam. This difficulty has been met in three ways.

(1) By superheating the steam so that it carries no watery vapour on entering the cylinder, and that it also carries a sufficient excess of heat to raise the temperature of the cylinder walls without lowering its own temperature below that at which it left the boiler.

(2) By fitting the cylinders with jackets, through which live steam is passed, either on its way into the cylinder, or by a special jet, which is allowed to condense and is drained off.

(3) By dividing up the range of expansion over several cylinders, the engines so constructed being known as compound, triple expansion, and quadruple expansion engines.

Superheating has already been dealt with. The question of steam jackets will be dealt with later on, and also the construction and working of compound, triple, and quadruple-expansion engines.

Meanwhile, it may be noted that, provided that cylinder

condensation can be got rid of, considerable economies are obtainable by the use of higher steam pressures in single cylinders, and that cylinders of a certain size may be made to do more work by using higher steam pressures than they would have with lower pressures.

### The Work a Steam Engine will Perform

The work a steam engine will perform depends directly upon the sectional area of the cylinder, upon the mean effective steam pressure working upon the piston, and upon the distance the piston travels in a given time. It will be remembered that 1 H.P. represents 33,000 foot lbs., and the work that steam cylinders are capable of performing is measured in H.P., the number of foot pounds being obtained by the formula—

$$\text{H.P.} = \frac{2PLAN}{33,000}$$

Where H.P. is the horse-power the cylinder will furnish, P is the mean effective pressure exerted on the piston, L is the length of the stroke of the piston in feet, the distance over which it travels when moving from one end of the cylinder to the other, and N is the number of revolutions of the crank shaft, or of double strokes of the engine per minute. A is the area of the piston in square inches.

The mean effective pressure is the mean pressure behind the piston, less the mean pressure in front of the piston. It has been explained that on the return stroke the piston has to drive out the steam from the cylinder that was employed in pushing the piston on the previous stroke. If the engine exhausts only to the atmosphere, the back pressure, as it is called—the pressure in front of the piston—will be that of the atmosphere, plus that remaining in the steam, and will be gradually decreasing as the piston reaches the end of the stroke. Whatever the mean of all the back pressure is, that has to be subtracted from the mean of all the pressures in front of the piston, and the result is the figure to be employed in the formula given above. This pressure, when multiplied by the number of square inches in the surface of the piston that is exposed to the steam pressure, gives the total pressure acting upon the piston—that is the total average pressure throughout the stroke; and this multiplied by the distance through which the piston travels in a minute, gives the number of foot pounds of work done by the piston. Thus, taking a piston having a diameter of 12 inches, its area will be 113 square inches, and if the mean effective pressure was, say, 40 lbs., the total pressure acting upon the piston is 4520 lbs. If the stroke of the engine is 12 inches, and it runs at 300 revolutions, or 300 double

strokes per minute, the travel will be 600 feet per minute, and the total work done in foot pounds will be 2,712,000, or about 82 H.P., as follows—

$$\text{H.P.} = \frac{40 \times 113 \times 2 \times 1 \times 300}{33,000} = 82.18 \text{ H.P.}$$

A point that perhaps may be as well mentioned here is, the steam cylinder is often fixed in a horizontal position, and even when it is fixed vertically, only one of the strokes is lifting, while we understand the rate of doing work as so many pounds *lifted* so many feet per minute. The explanation is, though the engine may be fixed horizontally, the motion of its piston is communicated to a crank shaft, or may be, and if a pulley be fixed upon the end of the shaft, and a rope be arranged to wind up on the pulley, the end of the rope being carried over a pulley at any given height and attached to a weight on the ground, or below the ground, it will do work in lifting the weight, just as if the power had been applied directly, the work done upon the weight being that delivered by the piston, less the charges for friction, etc.

## Indicated Horse-power and Brake Horse-power

Another point that had also better be explained, is what is meant by "indicated" horse-power, as distinguished from "brake" horse-power, and again from "nominal" horse-power. By indicated horse-power is meant the total power, or work, that the piston will perform, taking the horse-power at 33,000 foot lbs. per minute, or 550 foot lbs. per second, and it is found by the use of the formula given above for horse-power, the mean effective pressure being found by means of an apparatus called the indicator. It has been mentioned that the steam pressure falls gradually as the steam expands, after the entry port is closed, and that the pressure in front of the piston also falls gradually as the steam escapes. A little apparatus, to be described later, is arranged to measure this fall on each side of the piston, exactly as it takes place. The indicator draws a curved line upon a paper provided for the purpose, rolled on a cylinder, the height of the curved line above the horizontal line measures the steam pressure at each portion of the stroke, and the mean is taken of all of these lines, this being the mean pressure behind the piston. The same thing is done for the mean pressure in front of the piston, and the one is subtracted from the other. In some cases the two sets of pressure are taken on the same diagram, and they are then easily subtracted one from the other.

By "brake" horse-power, or as it is sometimes expressed, "actual"

horse-power, is meant the power that is actually available, or the work that can be actually done by the crank shaft of the engine, to which the piston delivers its power, and it is found by actual measurement, by a brake designed specially for the purpose, to absorb the power that is being measured, and it equals the indicated horse-power, less the power absorbed by the engine itself in friction, etc.

“Indicated” horse-power is not often referred to now, as engines vary very much in their efficiency.

The *efficiency* of the engine is the brake horse-power, divided by the indicated horse-power, and may range from 80 up to 95 per cent. In small engines, and in engines where lubrication is not properly attended to, or that are allowed to get dirty, the efficiency may be considerably lower than this; but large well-made engines should always give as much as 90 per cent. efficiency.

Where there is more than one cylinder, as in double cylinder engines, and in compound, triple expansion engines, etc., each cylinder is indicated by itself, and the total indicated horse-power of the engine is the sum of the horse-powers of each cylinder, using the indicated effective mean pressure in each.

“Nominal” horse-power is a term rapidly going out of use. It has no real meaning. It was a term adopted in the very early days of steam-engine work, by different makers, as a rough guide of what an engine would do. The indicated horse-power of an engine is very often from four to six times the nominal horse-power.

## Double=Cylinder Engines

Double-cylinder, or twin-cylinder, engines are not so common now as they were some years ago, because, with the increase of steam pressures, the second cylinder is now usually arranged on the compound principle. The twin-cylinder engine forms a very convenient arrangement for putting double the power within a small space, and for obtaining a more even turning moment on the crank shaft. It will be understood that the pressure upon the piston, varying as it does, as described, the turning effort conveyed by the piston to the crank shaft will also vary, and that with a single cylinder there will be a considerable variation, particularly where the engine is working very expansively, between the entrance of the steam and the end of the stroke. With two cylinders, having their crank shafts fixed either  $90^\circ$  or  $180^\circ$  apart, this difference is lessened; and, as will be seen with larger engines working very expansively, it is arranged to distribute the turning effort more and more evenly round the circle in which the crank shaft moves by increasing the number of cylinders, and by arranging the cranks evenly round the circle. •

## Compound Engines

The compound engine, as mentioned above, consists of two cylinders, through which the steam passes in succession, the cylinders being known as the high pressure (H.P.) and the low pressure (L.P.). The two cylinders are arranged to deliver their power to the same crank shaft, sometimes by being fixed side by side and having two cranks arranged either  $90^\circ$  or  $180^\circ$  apart, and sometimes, particularly with the high-speed engines to be described, the two cylinders are

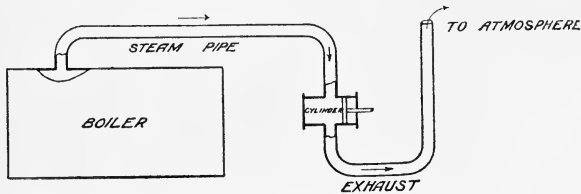

FIG. 86.—Diagram showing the course of the Steam, with a Non-condensing Simple Engine, from the Boiler to the Atmosphere.

placed one above the other, the same piston rod carrying the two pistons, and passing through the two cylinders. The two cylinders are always arranged to perform exactly the same work, that is to say, to furnish exactly, or as nearly as possible, the same amount of

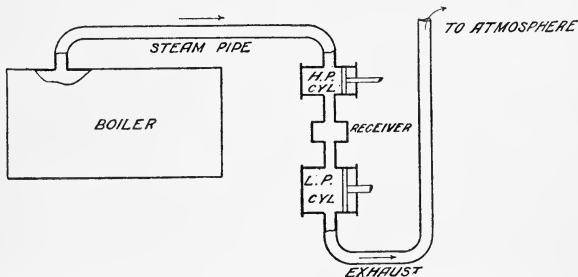

FIG. 87.—Diagram showing the course of the Steam, in a Non-condensing Compound Engine, between the Boiler and the Atmosphere.

energy. This means that the diameter of the low-pressure cylinder is larger than that of the high-pressure cylinder, because as the stroke of the two pistons must be exactly the same, and the pressure at which the steam is delivered to the low-pressure cylinder is considerably less than that at which it is delivered to the high-pressure cylinder, the only way in which the work done by the low-pressure can be made equal to that done by the high-pressure cylinder, is by

increasing the area of the piston. The same formula applies, but as the length and number of strokes are the same, the total pressure is made the same by increasing the area. The proportion between the cylinders varies with the conditions under which the expansion is

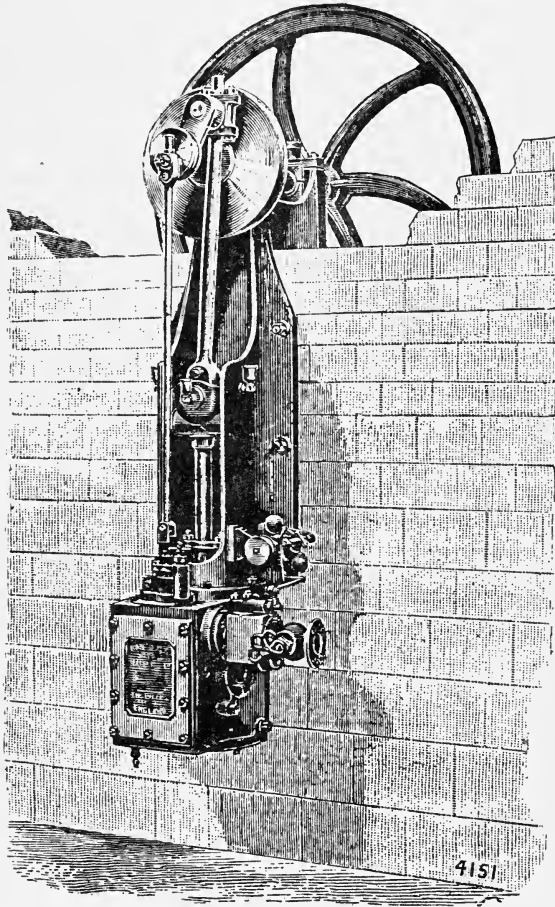

FIG. 88.—Single-cylinder Wall Engine, made by Ransome, Sims, and Jeffries. The bracket shown, bolted to the wall, supports the Engine.

carried out between 1 for the high-pressure and  $2\frac{1}{2}$  to  $4\frac{1}{2}$  for the low-pressure.

It will be understood that the steam passes first into the high-pressure cylinder, and from its exhaust valve to a receiver, and thence to the entry valve of the low-pressure, passing from the

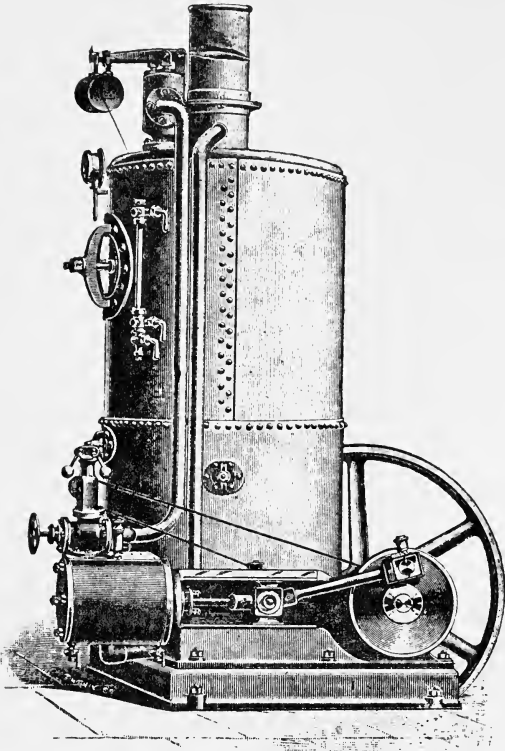

FIG. 89.—Single-cylinder Horizontal Engine, mounted with Vertical Boiler, made by H. Coltman & Sons.

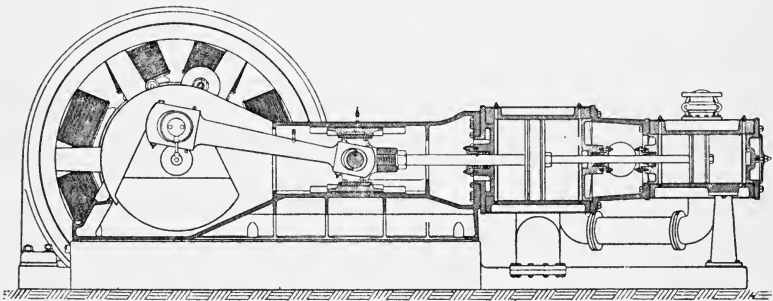

FIG. 90.—Longitudinal Section of a Tandem Compound Engine, without Receiver between. The high pressure is the rear Cylinder.

exhaust valve of the low-pressure either to the atmosphere, or to the condenser. It is very common now for the exhaust steam from the high-pressure cylinder to be reheated on its way to the low-pressure cylinder, the object being the same as that sought to be

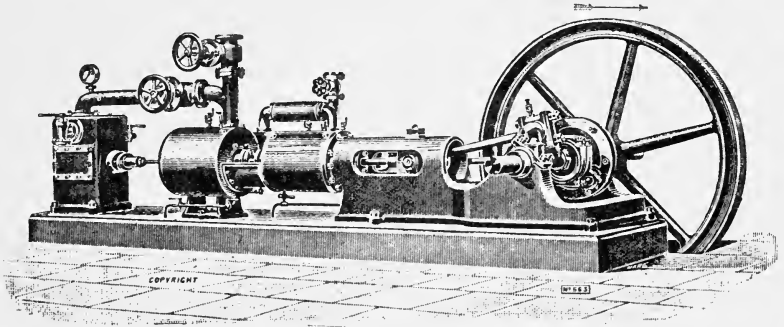

FIG. 91.—Horizontal Tandem Compound Condensing Engine, made by E. R. and F. Turner. The Condenser is mounted on the same Bed-plate as the Engine, and the Air-pump is worked from the Tail Shaft. The High-pressure Cylinder is in front in this case.

attained by superheating the steam, the prevention of the formation of vapour, and its condensation on the walls of the low-pressure cylinder.

Reheaters are of various forms, but mainly on the lines of the feed-water heater. In the reheater, the steam passing to the low-

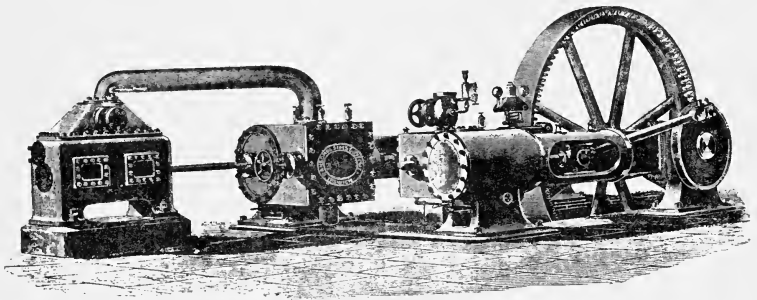

FIG. 92.—Horizontal Cross-compound Condensing Engine, made by Ransome, Sims & Co. The Condenser is mounted separately, and its Air-pump driven from the Tail Shaft.

pressure cylinder is carried through tubes, and a certain quantity of live steam through the space surrounding them. The reheater forms the receiver between the high- and low-pressure cylinders. The receiver between the two cylinders is the source of steam





PLATE 13A.—Galloway's Vertical Cross Compound Engine.

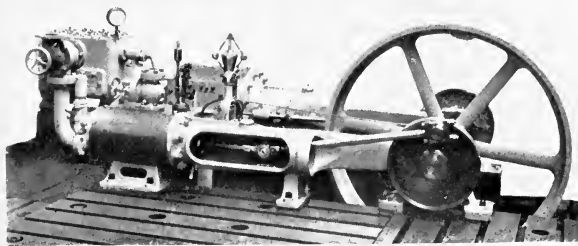

PLATE 13B.—Marshall's Horizontal Coupled Compound Condensing Engine, with Slide Valves.

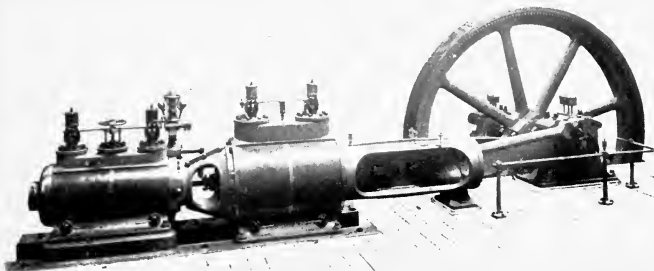

PLATE 13C.—Marshall's Horizontal Tandem Compound Engine, with Trip-gear Valves. [To face p. 224.]



for the low-pressure cylinder, just as the boiler, or steam range, is for the high-pressure. Figs. 86 and 87 show, diagrammatically, the course of the steam, from the boiler to the atmosphere, with simple and compound engines. Where condensers are employed, the steam

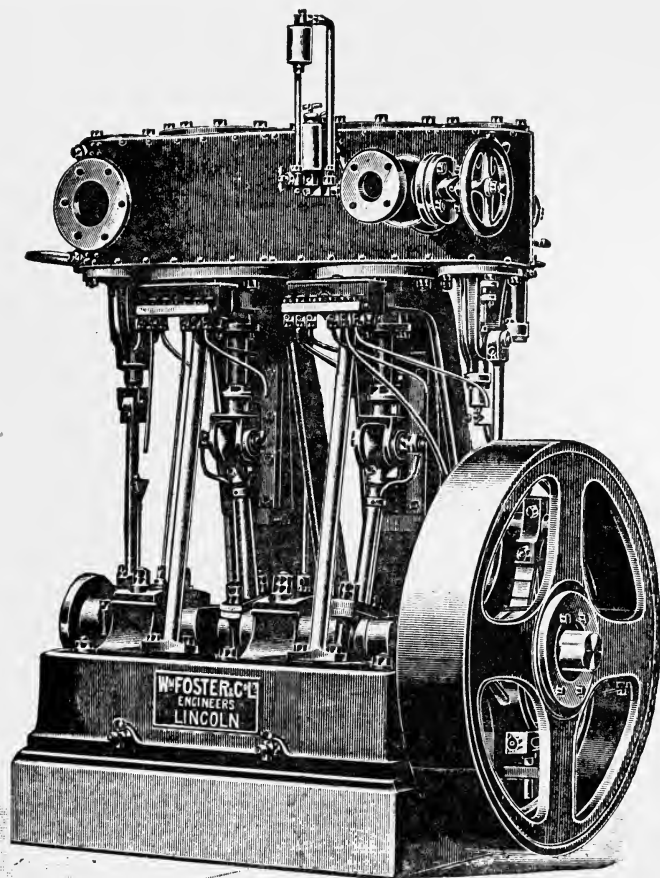

FIG. 93.—Compound Vertical Engine, unenclosed, with Shaft Governor.

passes from the low-pressure cylinder to the condenser, instead of to the atmosphere. Figs. 88 and 89, and Plates 10B, 10C, and 10D, are examples of simple engines of ordinary type, Figs. 90, 91, 92, and 93, and Plates 11A, 11B, and 11C, 13A, 13B, and 13C, and 14A and 14B, show various forms of compound engines.

## Triple-Expansion Engines

The triple-expansion engine may have three or four cylinders, known respectively as the high pressure (H.P.), the intermediate pressure (I.P.), and the low pressure (L.P.).

The low pressure is sometimes divided into two, the steam passing first to the high-pressure cylinder, then to the intermediate pressure, and then dividing between the two low-pressure cylinders. The reason of this arrangement is, in the case of the very high pressures that are used, in large steamships, for instance, and the large amount of power required, the low-pressure cylinder would be very large if arranged as a single cylinder; and, in addition, the fourth cylinder

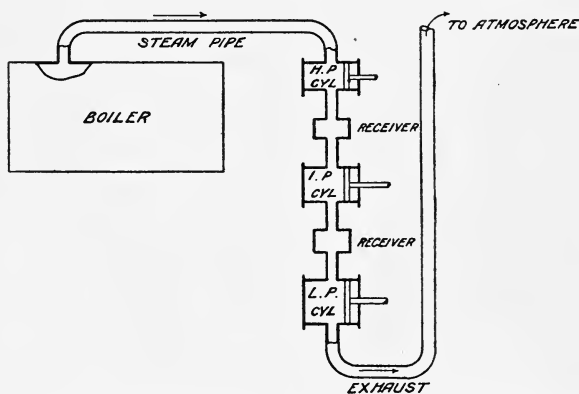

FIG. 94.—Diagram of the course of the Steam in a Non-condensing Triple Expansion Engine, from the Boiler to the Atmosphere.

gives another crank on the propeller shaft, and tends to give a more even turning moment.

The three cylinders, or the three sets of cylinders, must conform to the same rules as the two cylinders in the case of the compound engine. The high pressure, the intermediate pressure, and the low pressure, whether the last be of one or two cylinders, must furnish exactly the same horse-power. The horse-power furnished by each cylinder, or set of cylinders, should be that delivered to the crank shaft, as it will be evident that the friction of the different cylinders will not be the same.

The three cylinders, or sets of cylinders, are arranged in different ways. For ocean steamships, whether there are three or four cylinders, they usually stand side by side, vertically above the crank shaft, to which each of their pistons is connected. Plate 15A shows

one of these made by the Central Engineering Works. In high-speed engines employed on land work, and particularly in those forms used for driving electricity generators, various arrangements rule. In some cases the three cylinders are fixed one above the other, one piston rod answering for the three, and one crank shaft. In those cases it is not uncommon for the work the engine is to do to be split up between two or more sets of cylinders, so as to have two or more cranks. The arrangement of cylinders vertically one above the other is convenient for manufacturing purposes, since a simple engine becomes a compound engine by fixing an additional cylinder above, and a compound engine becomes a triple-expansion engine by fixing a third smaller cylinder above the other two. Receivers are used between the high-pressure and intermediate-pressure cylinders, and between the intermediate-pressure and low-pressure, and reheating is carried out in various ways.

### Quadruple-Expansion Engines

Quadruple-expansion engines may consist of four, five, or six cylinders. In fact, there is no reason that both of the two lower-pressure cylinders should not be divided up as convenient. They are known as high pressure (H.P.), first intermediate (First I.P.), second intermediate (Second I.P.), and low pressure (L.P.). Quadruple-expansion engines are only employed, so far as the author is aware, in ocean steamships. The same rules with regard to the power delivered by each cylinder, or set of cylinders, apply that have been mentioned for compound and triple-expansion engines, and the same arrangements are employed for receiving and reheating the steam between the different cylinders.

The four, five, or six cylinders are usually arranged side by side, vertically over the crank shaft.

### High- and Low-Speed Engines

By "high-speed engines" are understood those which make a large number of revolutions per minute, 300 and upwards; while "low-speed engines" are understood to be those which make a small number, 100 and under, per minute. There is an intermediate class of engines that have speeds ranging from 150 to 250 revolutions per minute, of which the engine shown in Fig. 93 is an example. The names are really incorrect. The proper classification of engines, so far as speed is concerned, is by the speed of the piston. Twenty-five and thirty years ago, 300 feet per minute was taken as the standard piston speed, and conservative engineers preferred a speed

a little less. To-day, 600 feet per minute is a fair standard, though some very large engines are run at lower speeds. It will be evident that the piston speed will be the same, of an engine running, say, at 400 revolutions per minute, if its stroke is 9 inches, and that of an engine running at 100 revolutions per minute, if its stroke is 3 feet. The term "quickly-revolving engines," was introduced by the late Mr. Morcom, of Belliss and Morcom, some years ago, but it does not appear to have been taken up, and the terms "high speed" and "low speed" are still used, the term "high speed" meaning those engines which have a short stroke and a large number of revolutions per minute; and "low speed," those which have a long stroke and a small number of revolutions per minute.

Examined from another point of view, also, the terms appear to be wrong, because while the piston speeds may be the same, the peripheral speeds of the flywheels of the so-called slow-running engines are often very much higher than those of the flywheels of the so-called high-speed engines.

The high-speed engine, to use the term commonly employed, is gradually making its way, though the engineers who have been developing it have had a great many difficulties in their way. Old engineers viewed with great concern the apparently quickly moving parts of the high-speed engine, and it may be stated that their concern was quite justified, as some of the early engines did as prophesied for them, and knocked themselves to pieces. The main difficulty was, however, that of lubrication, and this has now been completely overcome by the systems of splash lubrication adopted in the Willans and other engines, and the forced lubrication adopted in the Belliss and others. The high-speed engines are always enclosed, that is to say, their crank shafts, piston rods, etc., are enclosed inside a casing, in which the lubricating arrangements are carried on. The casing provides a chamber in the case of the splash lubricating methods for the lubricant, and it is also found convenient with the other forms of lubrication. The intermediate speed engines are not enclosed.

By splash lubrication is meant, the crank shaft runs in a fluid formed of a lubricant mixed with water, and, as it turns round, it churns the mixture up, throwing it over all parts of the crank shaft, piston rod, etc., and keeping everything fairly cool. One of the reasons, it will be easily understood, for enclosing the space in which the crank shaft, the piston rod, etc., work, where splash lubrication is employed, is to prevent the lubricant from being thrown all over the engine-house, and this applies more or less to all forms of high-speed engine.

There are several forms of high-speed engines on the market, all of them having certain parts common. In all there is the enclosure of the crank shaft mentioned, with doors on both sides provided for

examination and repair of the machinery inside, the enclosures being constructed in various ways. Messrs. W. H. Allen & Co. call their enclosure a cast-iron trunk. The cylinders, which are always above the crank shafts, are supported from the top of the enclosed space by distance pieces, usually of cast iron, which also, in some forms, act as guides for the piston cross heads. Fig. 95 shows longitudinal and transverse sections of a compound enclosed engine, made by this firm. Fig. 96 shows a compound enclosed Belliss engine, and Fig. 97 a compound enclosed Browett-Lindley. The Willans engine differs from the other high-speed engines in this respect, that it is completely enclosed from the top to the bottom.

In the double-acting high-speed engines made by Messrs. Belliss

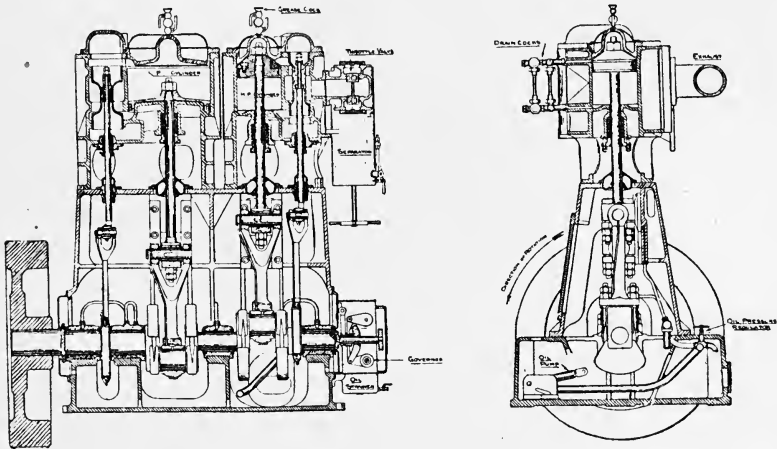

FIG. 95.—Longitudinal and Transverse Sections of Allen's Enclosed High-speed Engines.

& Morcom, W. H. Allen & Son, Browett & Lindley, Brotherhood, and others, the valves providing for the entry and egress of steam to and from the cylinder, are of the piston slide-valve type, or, as they are usually called, the piston type. In the Belliss engine, with compound engines, one piston valve, worked by one eccentric, distributes the steam to the two cylinders, the cranks of the two engines being arranged  $180^\circ$  apart, so that steam is entering one cylinder above the piston, and the other cylinder below the piston; this, it is claimed, tending to balance the strains upon the crank shaft, bearings, etc. With triple-expansion Belliss engines, there are two eccentrics and two piston valves, one supplying steam to the intermediate and low-pressure cylinders, and the other supplying steam to the high-pressure cylinder.

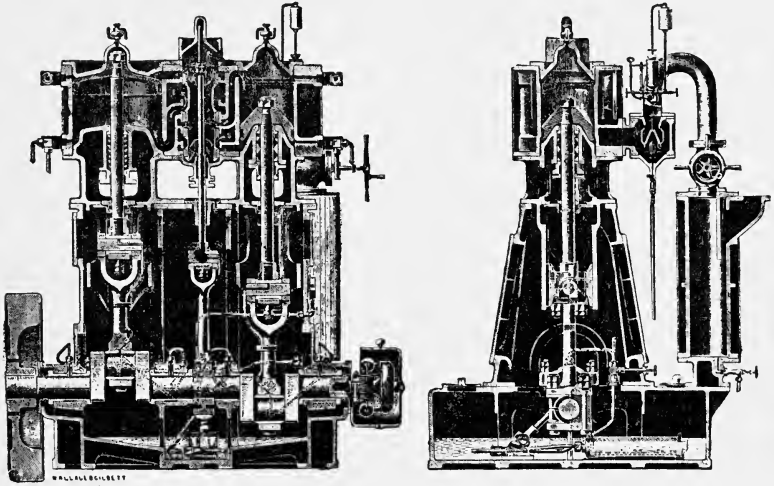

FIG. 96.—Transverse and Vertical Section of a Compound Belliss High-speed Enclosed Engine.

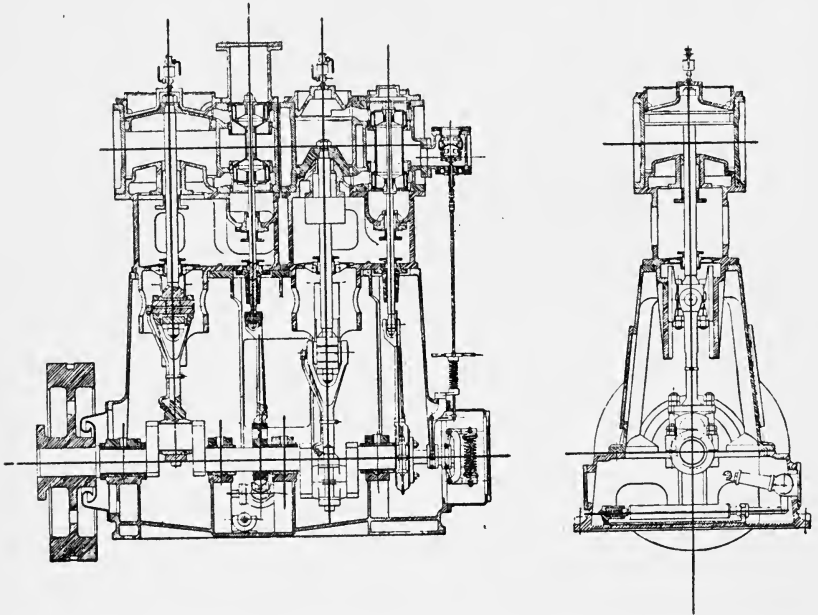

FIG. 97.—Longitudinal and Transverse Section of a Browett-Lindley Compound, High-speed Enclosed Engine.



In the Allen, the Browett, and the Brotherhood engines, piston valves are also employed, but there is one to each cylinder, and an eccentric to each valve.

In all of the double-acting high-speed engines mentioned, the bottom of the crank case is used as a reservoir for the oil into which it drains, after having been forced through the different bearings, etc., and it is taken from this reservoir by means of a valveless pump, the suction of the pump being protected by a strainer from any matter that may have got into the crank chamber. In the Belliss engine the oil pump is of the oscillating type, the oscillations enabling the apparatus to be worked without valves, that require to be opened and closed mechanically, etc. In all of them also the piston rods, connecting rods, etc., are provided with oil scrapers, intended to throw the oil from the rods down into the crank chamber. Any water that is formed in the cylinders also is allowed to drain into the crank chamber, and is removed from time to time.

The cylinders of high-speed engines are made of close-grained cast iron, machined all over. In the Brotherhood the iron is cast from selected scrap and cold blast pig, and the surfaces are strongly ribbed. The pistons are usually of cast iron. In the Brotherhood they are made of forged steel, with packing rings of hard cast iron. In the Browett the high-pressure piston is of cast iron, the intermediate and low pressure pistons of pressed steel with packing rings. The piston valves are usually of cast iron, with special packing rings.

All of the double-acting high-speed engines mentioned are controlled by throttle governors, worked from the crank shaft, the valve itself being moved by vertical rods, as shown in the drawings, leading up from the governor. The governors are of various forms, the two balls revolving on a spindle being a favourite one; but in the case of the Browett, the governor is carried on a disc, the governor balls being carried by arms pivotted on the disc. In all of the engines mentioned, the working parts of the governor are supplied with forced lubrication from the same supply as the bearings and other parts of the engine.

The question of the lubricant is a very important one in high-speed engines, and all of the makers recommend that a high class mineral oil should be employed. Messrs. Allen recommend that dry steam should be employed, and that superheating from 50° to 150° F. is an advantage; but they point out that with dry steam, it is necessary to supply additional internal lubrication to the cylinder, because the moisture contained in the ordinary saturated boiler steam acts as a lubricant.

## The Ernest Scott and Mountain High-speed Engine

Messrs. Ernest Scott & Mountain make two forms of engines, enclosed and non-enclosed, the enclosed engines, as explained, running at a higher speed than the non-enclosed.

The enclosed engines are made with two and three cranks, simple engines being made with two equal cylinders, compound engines with the usual differential cylinders, and three-crank compound engines being made with one high-pressure, and two low-pressure cylinders, the high-pressure cylinder being in the middle. A special feature of the engine is, the central valve that is employed to control the steam admission to the two cylinders, where two are employed, whether compound or simple. The steam-distributing valves are of the piston type, with the usual entrances to the steam cylinders, similar to those of the slide valve, one eccentric controlling the admission of steam to and the exit from both cylinders, by the position of the two piston valves. The piston valves are fitted with piston rings, with renewable cast-iron liners, claimed to ensure accurate opening and closing of the steam ports, and allowing for alteration of the cut-off if necessary.

The cylinders are supported from the crank case by the usual distance pieces, and the lubrication of all the parts is by oil under pressure, delivered by one or two pumps, at an approximate pressure of 20 lbs. per square inch.

## The Willans Central Valve Engine

In the Willans engine, which was one of the earliest of the high-speed engines to do really practical work, the late Mr. Willans, having carried out numerous experiments upon the working of steam in high-speed engines, a very special arrangement of valves rules, the piston rod performing the double office of carrying the power from the pistons to the crank shaft, and also of carrying the steam into, the different cylinders. The cylinders are arranged vertically above the crank shaft, and the crank shaft works in an enclosed crank chamber, as described on page 228, partially filled with a lubricant, the lubricant usually consisting of oil and water, and the crank shaft, as it moves round, splashing the liquid up upon the different parts of the apparatus. The steam chest communicates with the space at the top of each cylinder. As mentioned, the piston rod performs the office of distributing the steam, and in order to enable it to do so, it is made in the form of a tube or trunk. There is a rod

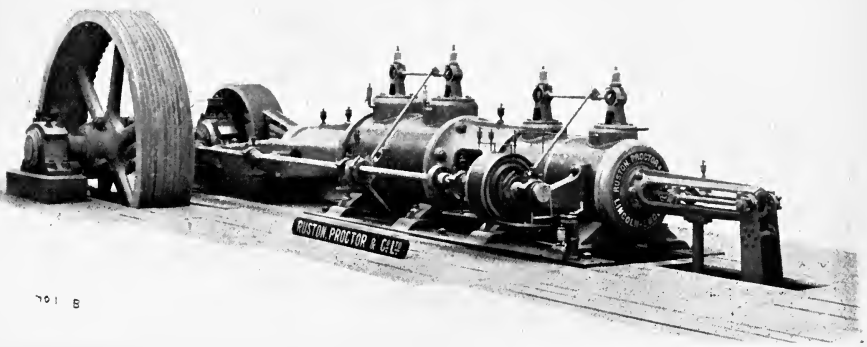

791 B

PLATE 14A.—Another View of Engine shown in Plate 11A.

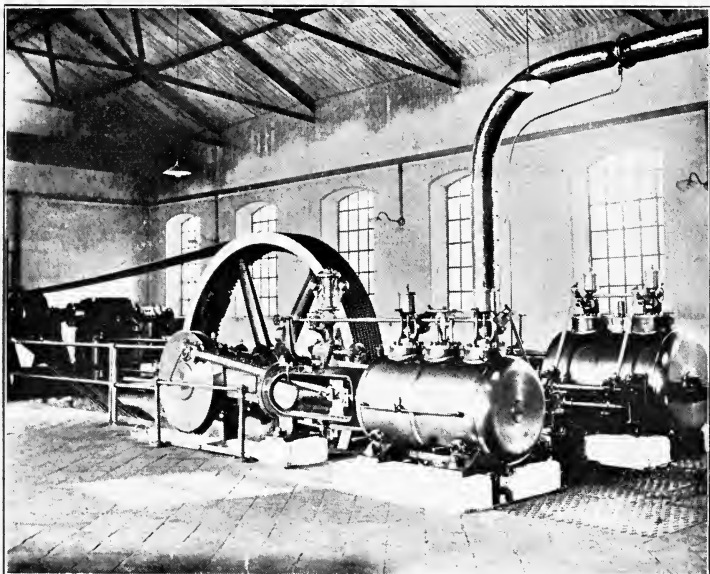

PLATE 14B.—Marshall's Coupled Compound Condensing Engine, driving a Dynamo by Ropes; the Cylinders have Trip Valve Gear. [To face p. 232.]



inside of the hollow piston trunk, carrying rings. These are the valves, and both the piston rod and the valve rod move, so that the positions of the valves change with reference to the ports in the piston trunk. The valve rod is moved by an eccentric, attached to, and worked by the crank, the end of the valve rod being secured to the crank-pin. The motion of the eccentric and of the piston give the requisite variation between the positions of the valves, relatively to the ports in the hollow piston trunk. The piston trunk itself ends in a guide piston, working inside an air chamber, formed by a cylinder closed at the top, the piston trunk passing through an aperture provided for it in the top. When the steam is first admitted to either engine it passes into the cylinder by way of the hollow piston trunk, when the ports are uncovered. Thus, when certain ports marked are uncovered, steam passes from the steam chest into the piston trunk, and when other ports are uncovered, the steam passes out of the piston trunk into the steam cylinder, driving the piston downwards. As the piston and the valve rod move, a valve first closes the entry ports, thereby preventing the admission of steam to the piston trunk, and later the exit ports are closed, preventing the passage of steam from the piston trunk into the cylinder. Later again, just before the completion of the stroke, the exit port and another are open, the steam then passing from the cylinder into the piston trunk, and from the piston trunk into the chamber under the piston.

It has been mentioned that the Willans engine is one of the few single-acting engines at present on the market. Steam is only admitted to the cylinder while the piston is moving downwards, the up stroke being obtained in each engine by the revolution of the crank shaft, this being accomplished by the fact that when one piston is ascending, the other piston is descending, the engines always being made in pairs, the two crank shafts being  $180^\circ$  apart on the crank. In the simple engine the steam passes from the chamber under the piston, into which it is delivered, directly to the exhaust. As the piston commences its return stroke, the guide piston, and the cushion or air cylinder immediately above it, come into operation. When the piston is at the lowest point of its stroke, two apertures in the air cylinder are open to the atmosphere, and are filled with air at atmospheric pressure. On the commencement of the up stroke, the air apertures are covered by the guide piston, and the air in cylinder immediately above the guide piston is compressed. The object of this arrangement is, to carry out the system of keeping the brasses of the cranks, etc., always in compression. It will be evident that as the steam pushes the piston downwards, the brasses between the connecting rod and the crank shaft will be forced downwards, and that there

will be compression between the connecting rod and the crank shaft. As the piston rises, the same action takes place, owing to the compression of air which is being carried out in the air cylinder. The work expended upon the compression of the air in the air cylinder, is not lost. It is converted into heat, and in the case of a heat engine, it is not necessary that the heat should be lost. The major portion of the work done in compressing the air is returned to the guide piston, and thence to the piston trunk, on the down stroke, when the air expands.

It was claimed by the inventor, and is by the makers, that any water in the cylinders is carried directly into the exhaust with the steam on the up stroke.

The simple engine is sometimes made with three cranks and three cylinders, the cranks being arranged at  $120^\circ$  apart on the crank shaft, and working in the same manner as described for the two cylinders.

With compound engines which consist of simple engines with the addition of smaller cylinders above, the action is exactly the same as in the simple engine. There are two more ports in the hollow trunk of the piston rod. The valve rod is extended, and carries two more valves, and the steam enters the high-pressure cylinder by first passing into the piston trunk by a valve, and out into the cylinder behind the piston by a port, the exhaust steam passing out of the cylinder by way of the piston trunk into the space underneath the high-pressure piston. There is the slight difference between the simple engine and the compound engine, that the exhaust space into which the steam passes, after doing its work in the high-pressure cylinder, forms the receiver for the steam that is to be employed in the low-pressure cylinder.

With triple-expansion engines, which Messrs. Willans & Robinson have named H.H.P. for convenience in fitting-shop work, there are again two smaller cylinders mounted above the high-pressure cylinders in the compound engine, the piston trunk extending up through the H.H.P. cylinder, and the valve rods also, the steam passing into the H.H.P. cylinder, by way of the piston trunk, and passing out to the exhaust space under the H.H.P. piston, through the piston trunk, the exhaust space, as before, forming the receiver for the steam that is to enter the H.P. cylinder.

It will be noted that with simple Willans engines, the steam only remains in the engine during one revolution of the crank shaft as in the ordinary reciprocating double-acting engine, during half of the revolution the steam being employed in driving the piston, and during the other half it being engaged in escaping out of the engine. In the compound engine the steam remains within the body of the engine, during two revolutions. That is to say, the steam entering

the high-pressure cylinder drives the high-pressure piston to the end of the down stroke, and during the up stroke, is engaged in passing into the receiver or steam chest for the low-pressure cylinder. During the next revolution the steam which worked the high-pressure cylinder during the first revolution, moves the piston of the low pressure cylinder, during the down stroke, escaping to the condenser, or the atmosphere, during the up stroke. With the triple-expansion engine, the steam remains within the body of the engine during three revolutions. During the first revolution it is employed in driving the H.H.P. piston, and in passing into the H.P. receiver. During the second revolution it is driving the H.P. piston and escaping to the low-pressure receiver, and during the third revolution it drives the low-pressure piston, and escapes to the atmosphere or the condenser. The lubricant for the crank chamber is filled into it through an oil funnel.

The Willans engine is controlled by a throttle governor, worked from the crank shaft. It consists of the usual pair of governor balls, revolving with the crank shaft, opposed by a spring, and working by the aid of a lever and a vertical rod, the entry valve to the steam chest. The steam enters by a pipe from the steam supply, passing through a valve leading from the pipe to the steam chest, in proportion to the amount the valve is open. The quantity of steam consumed by the engine is controlled entirely by the throttle valve, under ordinary circumstances, but apparatus are added when required to enable expansive working to be employed as well. The cut-off is controlled by the position of the gland rings, through which the piston trunk passes at the top of each cylinder, their position being arranged by the aid of distance pieces.

There are valves between the H.H.P. distribution valve and the H.P. valve, and also between the H.P. distribution valve and the L.P. distribution valve.

The low-pressure cylinders of all Willans engines, and the high-pressure cylinders of a certain size, are fitted with internal relief valves, consisting of gun-metal plugs, screwed into the top of the cylinders. The plugs are pierced with holes, and are covered by gun-metal discs. When the discs are raised, as when the pressure in the cylinder is above a certain figure, there is free communication and free passage for the steam between the cylinder in which the plug is fixed, and the receiver or steam chest above them. The discs are kept down under ordinary working conditions by the excess of the pressure in the receiver, or the steam chest, above that in the cylinder, a spring assisting. It is stated by the makers that the arrangement forms a perfect automatic relief, in case there is water present in the cylinder.

## Bumsted High-Speed Engine

The Bumsted high-speed engine, made by Messrs. Bumsted and Chandler, was made only single acting up to a few years ago, now however two patterns are made, single acting for sizes up to 300 H.P., and double acting for sizes up to 600 H.P. Both forms of engine are made with one, two, or three cranks, and for simple and compound

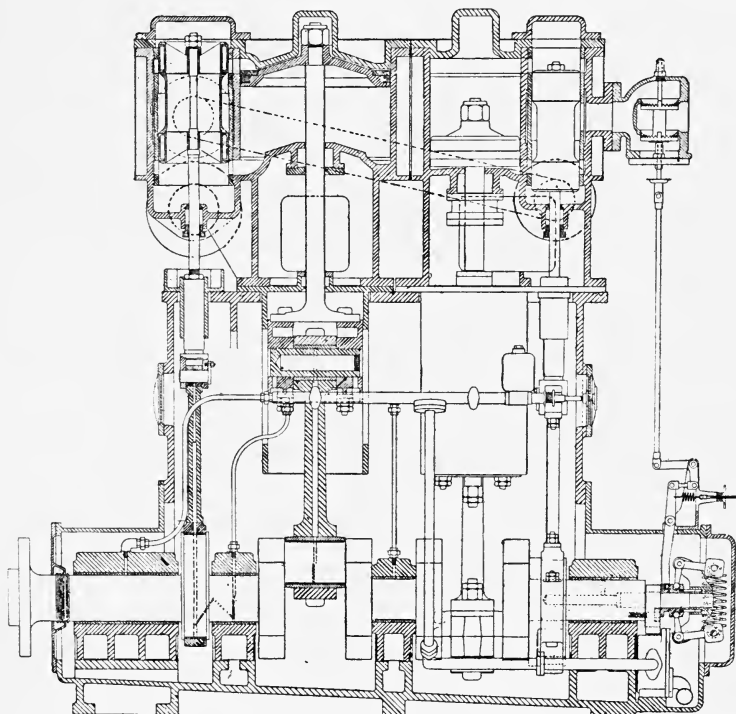

FIG. 98.—Longitudinal Section of Bumsted Double-acting Compound Enclosed Engine, with Shaft Governor.

engines, the double-acting engine being also made for triple expansion. In both forms of engine the valves are of the piston type.

In the single-acting engine the steam is worked in a very similar manner to the Willans engine. It passes first into the high-pressure cylinder, driving the high-pressure piston to the end of its stroke, then passes to the lower side of the high-pressure piston, this space acting as a receiver; and at the next stroke it enters the low-pressure cylinder above the piston, drives the piston to the end of its stroke, and then escapes to the exhaust. The lubrication of the crank and



working parts is effected on the splash system, the crank shaft revolving in a bath of oil and water.

In the double-acting engine, the bottom of the crank pit is used as an oil reservoir, as in the other engines that have been described, a valveless oil pump delivering the oil under pressure to the bearings and working parts. The governor is of the throttle type, worked from the crank shaft. Fig. 98 is a sectional drawing of a double-acting Bumsted compound enclosed engine, and Plate 16A shows a single cylinder Bumsted enclosed engine, Plate 16B a compound enclosed engine made by Easton and Bessemer.

## The Peache Engine

The Peache high-speed engine, which is made by Messrs. Davey, Paxman & Co., is also single acting, and it has several important distinguishing features.

It is nearly always made with three cranks, and with two cylinders, high- and low - pressure, above each crank. A transverse sectional drawing of the engine is shown in Fig. 99. The crank shaft works in a bath of oil and water, as in the other cases, and it has the special feature, that in place of being fixed directly below the centre line of the cylinders, it is out of line, a little to the front of the engine, the makers claiming that this gives a nearly straight connecting rod during the downward working stroke, and keeps a pressure on the back cross-head slide. The valves also are special to the engine. They stand behind the engine, and are not worked by eccentrics, as is usually the case, but by the

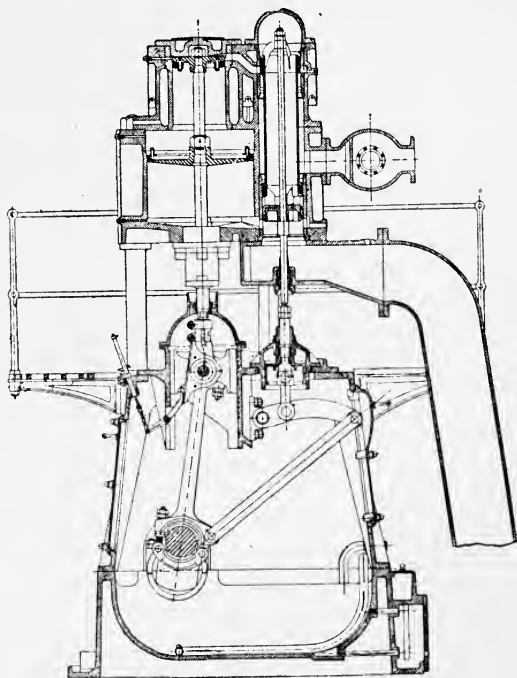

FIG. 99.—Transverse Section of Peache High-speed Single-acting Enclosed Engine.

rocking lever shown in Fig. 99, working from a rod attached to and receiving motion from the connecting rod. As will be seen, the valve rod is fixed vertically, and works vertically, and moves the two valves, that controlling steam to the high-pressure cylinder, and that controlling steam to the low-pressure cylinder, by one operation. In addition, there is an air-buffer cylinder, that will be seen just above the rocking lever, which is employed to overcome the inertia of the valve at certain portions of the stroke, air being compressed at other portions, and giving up the energy delivered to it to overcome the inertia of the valve when required. As will be seen from the drawing also, the high- and low-pressure cylinders are virtually one, merely divided by the piston, and they are caused to act as high- and low-pressure cylinders by the distribution valves. The steam enters by the throttle valve, which is shown on the right in Fig. 99, into the space surrounding the valves, which forms the steam chest. From this it passes under the edge of the high-pressure valve, to above the high-pressure piston, and after it has forced the high-pressure piston to the end of its stroke, it is exhausted over the top of the high-pressure valve, down through the main body of the valve, and over the top of the low-pressure valve, to the *under side* of the low-pressure piston, forcing the low-pressure piston upwards, the high-pressure piston going with it, since, as will be seen, the high- and low-pressure pistons are on one piston rod. The space between the high- and low-pressure pistons is called the controlling cylinder, and is arranged to be connected and disconnected by the motion of the high-pressure piston, from the space above the high-pressure piston. Hence, this space is alternately filled with steam at the same pressure as exists above the high-pressure piston, the steam is expanded, and is compressed by the upward motion of the low-pressure piston; the object of the action in the controlling cylinder being to balance the upward inertia of the pistons, cross head, connecting rod, etc., on the up stroke, so as to keep a slight excess of pressure in a downward direction throughout the up stroke. The work done in compressing the steam in the controlling cylinder on the up stroke, is given out again on the down stroke, by the expansion of the steam, it acting upon the low-pressure piston, at the same time as the steam from the steam chest is acting upon the high-pressure piston. It is claimed that the arrangement of the valves behind the cylinders enables the space occupied by the eccentrics in other engines to be dispensed with, making the engine more compact. The engine has its crank chamber enclosed, with doors for access, the cylinders being supported from the crank chamber by steel pillars. It will also be noticed that the connecting rod works in a gland above the crank chamber, the gland forming the end of a dome-shaped cover, which prevents oil, etc., from passing upward.

The valve motion described is made for cut-offs from 0·4 to 0·5, from 0·5 to 0·6, and from 0·6 to 0·7 in the high-pressure cylinders, these are fixed cut-off gears. The engines are also made for adjustable cut-offs by automatic governors. The governor of the Peache engine acts on the throttle valve, as in the other cases.

## Vertical and Horizontal Engines

Engines are arranged with their cylinders either in a vertical or horizontal position. The older forms, the slow-speed, and a large number of the intermediate speed engines, are arranged with their cylinders horizontal, the cylinders and the crank shaft being fixed on one casting, forming a bed plate. The high-speed engines, as mentioned, are nearly always arranged with their cylinders vertical and inverted, that is to say, the cylinder stands above the crank shaft, the piston rod projecting below the cylinder, and the crank shaft being carried by a casting specially arranged for it, from which pillars rise to support the cylinders and the walls of the enclosing chamber. The intermediate speed engines are also often arranged with their cylinders vertical, and inverted above the crank shaft.

Where there are two cylinders, as in the case of compound engines, or twin-cylinder engines, it is very common to carry a fly-wheel on the crank shaft between the engines, the cylinders being carried on separate castings, when of the horizontal type, and in one casting when of the vertical type. As already explained, the high- and low-pressure cylinders of compound and triple-expansion engines, are sometimes carried side by side in the vertical type, and sometimes one over the other. A similar arrangement rules with horizontal engines, the high, low, and intermediate cylinders are sometimes carried in one line, tandem, on the same bed plate, and sometimes side by side. Examples of these are shown in Plates 11 to 14, and Figs. 90 to 92. Double compound engines of the horizontal type are somewhat common, especially for pumping plant, two compound engines being carried on each side of a flywheel, the two cylinders of each of the engines being sometimes one behind the other, and sometimes side by side.

For driving electricity generators, and compressed air machinery, and, in fact, any machine in which a uniform speed and a uniform turning moment is of importance, it is necessary to have a flywheel, and this is sometimes carried, as explained, between the cylinders, in some cases being made to form part of the electricity generator, while in other cases, as in the Belliss, Morcom and other engines, the flywheel is carried between the end of the engine shaft and the dynamo shaft.

One of the difficulties that has arisen in connection with the lubrication of high-speed engines, now that the initial difficulty of lubricating continuously has been overcome, is the tendency of the lubricant to work outwards from the enclosing chamber by every path that is open to it. Thus, where high-speed engines are connected to electricity generators, it is sometimes found that the lubricant of the engine finds its way over into the armature or revolving portion of the dynamo, and gives rise to some trouble.

## Lancashire Mill Engines

Lancashire mill engines have long had the reputation of being the most economical engines, so far as the consumption of steam and coal is concerned, that are to be found anywhere. The Lancashire mill consists usually of a large high building, on each floor of which are a very large number of spinning machines, all driven from shafting, and the whole of the shafting on all the floors is driven from a primary shaft, which in its turn is driven by ropes from a heavy flywheel pulley, worked by a pair of engines, between which the pulley is fixed. The engines are sometimes compound, and sometimes triple expansion, there being the usual controversy as to which is the better arrangement.

The rope drive, however, is gradually being displaced in the mills that are now being put down, and in some of the older mills, by the electric motor drive, the main engines being employed to drive a generator in the engine-house, and a motor being fixed either on each floor, or more than one on each floor, taking current from the main generator, and driving the shafting, which in its turn drives the spinning machinery. As an illustration of the horizontal triple-expansion condensing engines that have done such good work, the following made by Messrs. Daniel Adamson, of Dukinfield, will probably be interesting. The engine is shown in Plate 12. There are two cylinders on each side of the driving pulley, the low-pressure cylinder being divided into two, as explained on a previous page. On one side is the high-pressure cylinder, and one low-pressure cylinder, and on the other side is the intermediate and the other low-pressure cylinder. The high-pressure cylinder is 14 inches diameter, the intermediate 24 inches, and the two low-pressure cylinders each 26 inches, the common stroke being 4 feet, and the engine running at 70 revolutions per minute, and delivering 600 I.H.P. with an initial steam pressure of 160 lbs. per square inch. It will be noticed incidentally that the piston speed is 560 feet per minute, which is practically the same as that of the so-called high-speed engines. The pistons of the high-pressure and

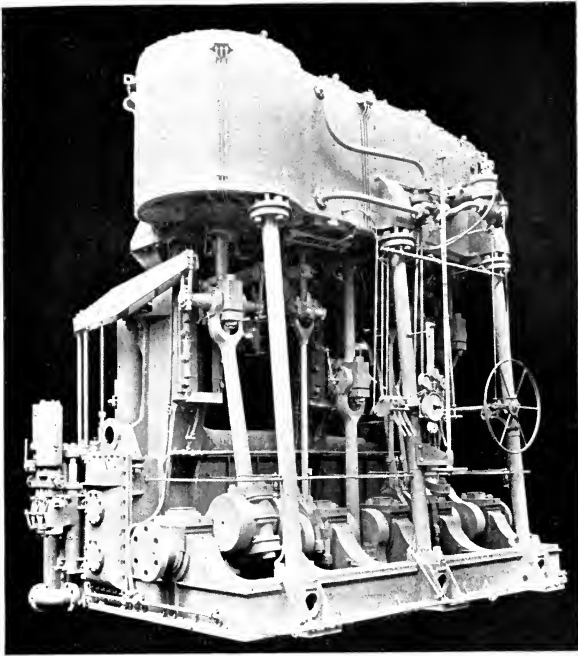

PLATE 15A.—Triple Expansion Marine Engine, made by the Central Engineering Works, Hartlepool.

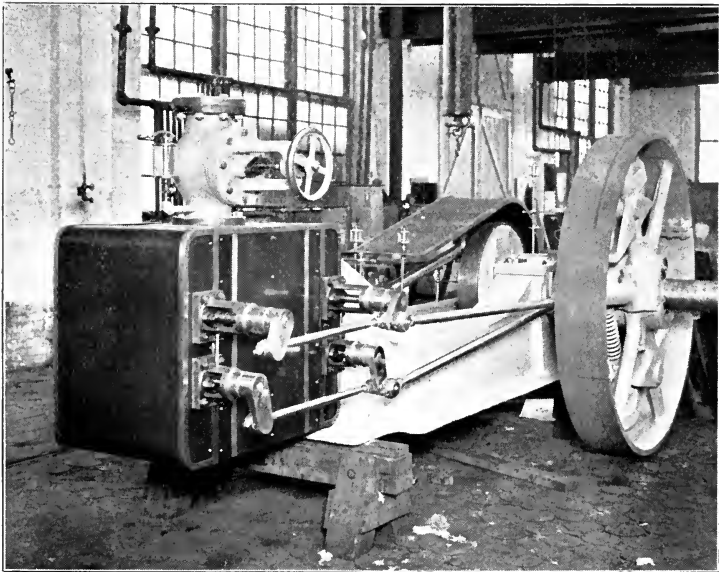

PLATE 15B.—Single Cylinder Corliss Valve Engine, with Shaft Governor, made by the Atlas Co. [To face p. 240.]



low-pressure are attached to one piston rod, and deliver by one connecting rod to one crank shaft on one side of the driving pulley, the pistons of the intermediate and low-pressure cylinders being also on one piston rod, and delivering by one connecting rod to a crank shaft on the other side of the driving pulley. Each pair of engines has its own governor, its own condenser, air pump, and boiler-feed pump. The high and intermediate cylinders, and the working parts of the engine, are fixed on trunk girders, and the two engines are provided with distance pieces, the low-pressure cylinders being fixed on separate cast-iron bed-plates, secured to the foundations, provision being made for the feet of the cylinders to slide freely, so as to

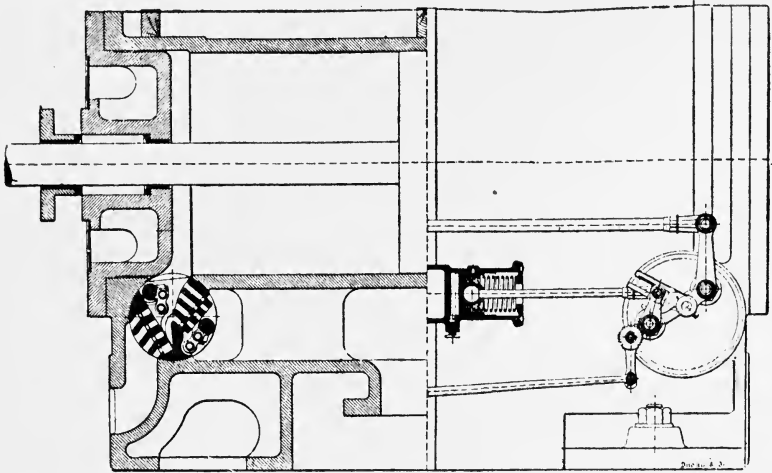

FIG. 100.—Section of Cylinder of Lancashire Mill Engine, with "Wheellock" Valves. The Valve is seen in section below the Cylinder, on the left. It controls the entry and exit of the Steam, and is claimed to combine the advantages of the Slide and Corliss Valves. The Expansion Gear is shown on the right.

accommodate themselves to the expansions and contractions of the engines. The condensers are fixed underneath the main frames of the engines, the air pumps and boiler-feed pumps being also fixed there. The air pumps are driven direct from the main engine cross head by steel plate levers and links provided for the purpose, and the boiler feed pumps are driven from the air-pump levers.

The driving pulley is 18 feet in diameter, and is grooved to take twenty  $1\frac{5}{8}$  inch ropes, the speed of the ropes being 3960 feet per minute, and the drum being built up in segments.

The high and intermediate cylinders are each fitted with automatic expansion gear controlled by their own governors, the expansion gear being of the Wheelock type, the general arrangement of

which is shown in Fig. 100. The valves also are of the type B Wheelock pattern, and the gridiron arrangement is clearly shown in the sectional drawing. The automatic expansion gear is claimed to give control of the expansion from zero up to 75 per cent. of the piston's stroke while retaining complete control of the periods of release and compression. It is claimed that the arrangement of a toggle joint between the valve grids and spindles gives almost instantaneous opening and closing, with great ease of action under extreme pressures. Instantaneous opening and closing, it will easily be understood, is of great importance, inasmuch as it gives the engineer practically complete control of his engine. Plate 17A shows a horizontal cross compound with engine, made by Messrs. Galloway.

### Reciprocating Valves for Engines

It has been explained that the piston is caused to move to and fro in the cylinder of the engine by the admission of steam alternately on each side of it, and one of the problems which engine builders have had to solve has been the construction of a valve that would accomplish this. There are the following forms :—

*The slide valve.*

*The Corliss valve.*

*The Cornish valve.*

*The trip, or drop, valve.*

*And special forms of valves, such as the central valve employed in the Willans engine and others.*

The slide valve was the earliest form. The problem, it will be understood, is to bring the supply of steam, which is usually contained in a part of the engine called the steam chest, into connection with the end of the cylinder, to which steam is to be admitted at the moment, and to bring each end of the cylinder into connection with the exhaust later. It should, perhaps, be mentioned first that the cylinder of the steam engine nearly always forms part of a casting in which the entry valves, as the valves controlling the admission of steam are called generically, are arranged to work, and also with a space or chamber, called the "steam chest," into which the steam is admitted from the steam pipe, and from which it passes through ports at each end of the cylinder into the cylinder at the proper moment. What is called a "stop valve," which controls the admission of steam from the steam pipe to the steam chest, is fixed between the steam pipe and the casting forming the cylinder. The governor, which also controls the admission of steam to the steam chest, is frequently carried by the cylinder casting. The stop valve is an arrangement consisting of fixed portions and a moving portion, which is moved usually by turning a hand wheel. As the wheel is turned in one direction, a small opening is made between the



parts of the valve, through which the steam enters and passes to the steam chest. As the valve wheel is screwed back more and more, the space through which the steam passes is increased until the valve is wide open and the sectional area of the space available for the steam is equal to that of the steam pipe supplying the engine. When there is a governor also carried by this part of the engine, it is of the throttle type, that is explained further on, and it performs exactly the same operation automatically, in obedience to changes of rate of motion received from the crank shaft, as the stop valve does when moved by hand. It will be understood that the supply of steam to the engine can be controlled by the stop valve, and that when the engine is only required to do small work the stop valve is only open a small distance, and when more work is put on it, the stop valve is opened wider, and so on. With properly governed engines, it is usual, in a great many forms of work, to throw the stop valve wide open when once the engine has taken its load, and leave the governor, as will be explained, to control the supply of steam. On the other hand, in some cases the control afforded by the stop valve is of great service. Such a case is that of alternate current electricity generators, driven by steam engines, at the moment when a particular generator is being brought to synchronism with the others already at work. One of the factors in the problem of synchronism is the speed of the generator, and this is controlled most easily by the stop valve. When an alternating current generator is to be connected to the bus bars, the engine driver gradually brings it up to about its proper speed by gradually opening the stop valve, and he and the switch-board attendant bring it to synchronism, by alternately moving the stop valve and changing the exciting current of its field magnets. Similarly, when any engine is being started from rest, it is brought gradually up to speed by gradually opening the stop valve. One reason for this is, the engine being cold, condensation will take place very rapidly, and give some trouble unless the cylinders are warmed up. They are warmed by the admission of a small quantity of steam through the stop valve, the drain cocks, which are fitted to all cylinders, being opened to allow any water that is formed by condensation, or that may have been present, to be driven out by the steam. The stop valve, as explained on page 256, is itself warmed before being put in operation, by steam passing through a small bypass arranged for the purpose.

### The Slide Valve

The slide valve, as its name implies, slides upon a planed surface provided for it, usually on the side of the cylinder. Sections and

forms of slide valves are shown in Figs. 101 and 102. In its simplest form, it consists of a metal box of rectangular section without a cover,

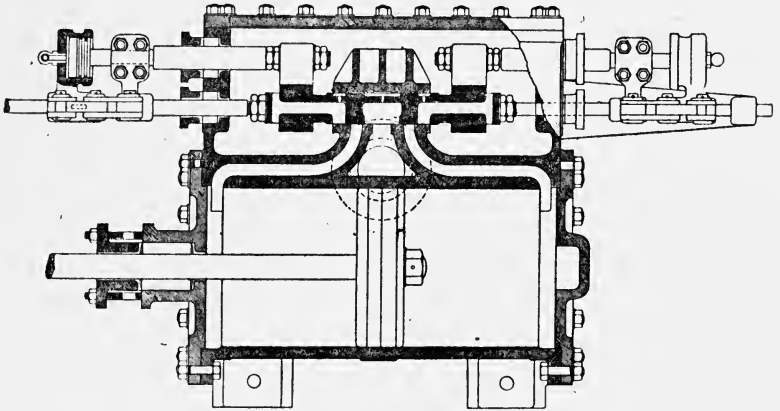

FIG. 101.—Section of one form of Slide Valve.

the hollow portion being placed against the surface of the cylinder upon which it slides. It is sometimes fitted with projections, laps as

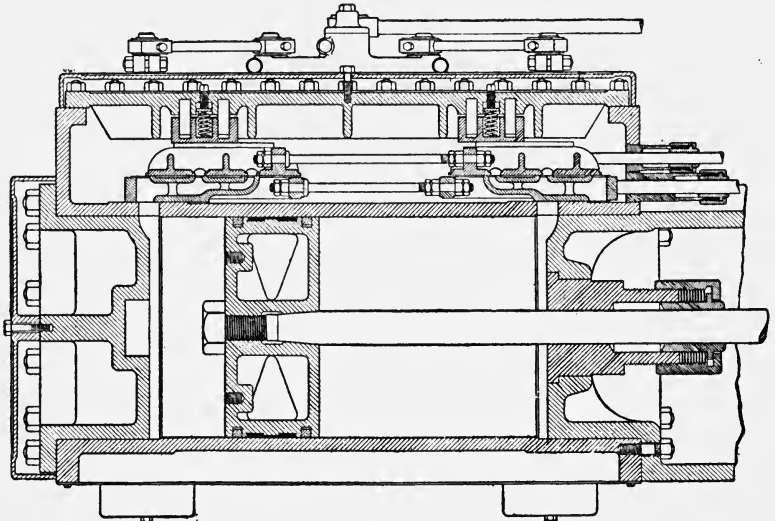

FIG. 102. Section of another form of Slide Valve.

they are called, on each side of the walls of the box. The box moves to and fro inside a slide case forming the steam chest, to which steam

is admitted, as shown in the figures, and the steam passes into the cylinder through either of the ports leading to either side of the piston, when the slide valve uncovers that port and leaves it open to the steam present in the steam chest. The *modus operandi* is as follows: With the valve in its middle position, both of the ports leading into the cylinder are closed by the slide valve standing over them. As the valve moves to the right the cylinder entry port on the left is gradually uncovered, the steam then passing from the slide jacket through that entry port behind the piston, which then, as explained, is moved to the right in the cylinder. At a certain period of the stroke, arranged, as will be explained, by the aid of the eccentric controlling the travel of the slide valve, the valve commences to return, and gradually closes the entry port to the cylinder on the left. After the valve has travelled a certain distance, the entry port on the left is not only closed to the space behind the valve but is open to the hollow space in the middle of the valve, and this is open to the exhaust by the passage shown. At the same moment, though sometimes a little later, and again sometimes a little earlier, according to the conditions of working, the wall of the slide valve on the right commences to uncover the entry port into the steam cylinder on the right, the steam then passing into the cylinder behind the piston, which is now at the right hand of the cylinder, the piston now commencing to travel from right to left. At a certain portion of the stroke, the slide valve again commences to return, gradually closing the entry port on the right, and then opening the entry port to the hollow space in the middle of the slide and thence to the exhaust, the entry port on the left then commencing to be uncovered, and so on.

For large engines, however, the simple slide valve is not found satisfactory, because it would be obliged to be made too large and to have a very long travel. To meet this, double-ported slide valves are employed, in which the entry ports to the engine cylinder are larger than with the simple slide valve, and there are two spaces leading into them which are swept over by two portions of the surface of the slide valve. The slide valve, again, is divided up, the central portion and the portion surrounding the two additions on the right and left making connection with the exhaust, while the back of the slide, where the steam chest is, is in communication with the additional portions to right and left. Taking the valve in its central position, with all ports closed, and suppose it to move to the right, the left-hand portion of the left-hand entry port will be uncovered by the main body of the slide, while the right-hand portion of the same entry port will be placed in communication with the hollow part of the left-hand addition to the slide, which is also in communication with the steam chest, the steam then passing through both

portions of the entry port into the steam cylinder to the left and behind the piston, forcing it over to the right. At a certain portion of the stroke, the slide valve commences to return and to gradually close the two portions of the entry port, and, later, to open both portions, one to the hollow space in the centre of the slide, and the other to the space on the left leading to the same hollow space, and both leading to the exhaust. The action of the double-ported slide is exactly the same in other respects as that of the single-ported. As the slide moves again to the left, the steam is admitted to the right-hand entry port behind the piston which is now at the right-hand end of the cylinder, and commences to move it to the left, and again, at a certain portion of the stroke, the slide commences to close both portions of the right-hand entry port, and a little later to open both to the hollow portion of the valve, and thence to the exhaust.

### Giving Motion to the Slide Valve

Motion is given to the slide valve by means of a rod worked from the crank shaft, the to and fro motion being obtained by what are termed eccentrics. It is well understood that when a disc is pivoted at its centre, any rod attached to its periphery will have a to and fro motion exactly the same in each direction, just as the crank shaft has; in fact, in some cases, a disc is employed in place of a crank shaft. A disc, however, has the advantage, by proper arrangement, that the amount of the to and fro motion can be regulated. Thus, if a rod is connected to the periphery of a disc 12 inches in diameter, the total travel of the rod will be 12 inches, while if it is connected to a point only 1 inch from the centre, its travel will be only 2 inches, and so on in proportion. The rod which gives motion to the slide is connected to a certain point on a disc, the disc working on the crank shaft, the travel of the crank shaft, or the throw of the eccentric, depending upon the distance of the attachment of the rod to the disc from the centre of the crank shaft. In expansion governors, as will be explained, it is arranged to increase or decrease the throw of the eccentric by the increase or decrease of speed of the engine.

The object of this is to increase or decrease the time during which the entry port of the cylinder is open to the steam chest. It will be understood that as the slide valve moves across the cylinder, it gradually exposes a portion of the cylinder entry port to the steam chest. As it moves onward in the same direction, the space opened gradually increases until, if it is allowed to do so, the entry port is fully exposed to the steam chest. This is the case explained on a previous page, where the engine is not worked expansively, and

where the steam merely pushes the piston to the end of its stroke. It was explained, however, that for economy the steam is only allowed to enter for a certain portion of the stroke, usually from half of the stroke downwards to as low as one-tenth, and this is accomplished in the case of the slide valve by only allowing it to travel  $\frac{1}{2}$ ,  $\frac{1}{4}$ , or  $\frac{1}{10}$ , as the case may be, of the stroke before it commences to return, the amount of travel being arranged so that the port only remains open altogether for the proportion of the stroke decided upon. This variable length of travel of the slide is accomplished by varying the position of the pin upon which the eccentric rod works in the disc which carries it round the crank shaft. For reversing the engine two eccentrics are employed, one taking charge of the slide when the engine is running in its normal direction, and the other taking charge of it when the engine is running in the reverse direction. It will be understood that the direction of motion of the engine can be reversed by admitting steam to the opposite side of the piston to that at which it would be admitted to move it in the direction in which it would travel if running normally, and this is accomplished by what is called link motion, and which is arranged to change the eccentric controlling the motion of the slide rod from that which moves the slide, so that steam enters the cylinder normally, to that which moves the slide, so that it enters on the opposite side of the piston. The link motion consists of a link or arc of a circle, to which the rod moving the slide is attached in such a manner that the pin connecting it to the link can move along from one end of the arc to the other. To the ends of the arc are attached the two rods connected to the two eccentrics, one at each end of the arc. When the slide rod is midway between the two eccentric rods there is no motion of the slide rod at all, and when it is pulled to one end of the arc it forms a continuous rod with one of the eccentric rods, that eccentric then controlling the slide motion, the other one being out of gear. To reverse the direction of motion, the slide valve is moved through the arc to the other end, where it forms a line with the other eccentric rod which then controls the slide motion.

### Objections to the Slide Valve

There are several objections to the slide valve, which have gradually caused it to fall into disuse. One is, that considerable leakage of steam often takes place, owing to the valve surfaces becoming worn, and providing a space through which the steam escapes. If the slide valve is to accurately control the admission of steam to the engine, there must be no possibility of the steam escaping, say, along the face of the slide to the exhaust valve; but

this is what takes place, unfortunately, when the slide is worn, the steam so passing being lost for useful purposes, and increasing the amount of coal consumed in the boiler furnace uselessly. Further, the steam which passes through the cracks so formed tends to increase them, and thereby to increase the leak. On the other hand, there are complaints that very great friction is often set up between the face of the slide valve and the surface of the cylinder upon which it works, owing to the pressure of the steam behind the slide, this friction leading to wear and to leakage. This has led to various forms of what are known as balanced-slide valves, in which smaller slide valves are placed behind the main valve, and are so arranged as to relieve the pressure of the steam upon the back of the valve, and facilitate its comparatively easy motion.

### Lap and Lead of Slide Valve

The surface of the slide valve that is in contact with the surface of the cylinder over which it moves, extends beyond the actual cover forming the port through which the steam passes to the cylinder and to the exhaust, and these extensions at either end, it will be easily understood, tend to change the time during which the entry port is open to the steam chest; and, again, during which the other entry port is open to the exhaust. These extensions are known as lap and lead, and they can be arranged to effect, permanently, what is effected by the variation in the throw of the eccentric.

### The Piston Slide Valve

In the piston slide valve the admission of steam to the cylinder, and the egress of steam from the cylinder to the exhaust pipe, are controlled by valves having the form of short solid cylinders, similar in form to engine pistons, and known as piston valves. They perform exactly the same office as the slide valve does, and in very much the same way. There is the same steam chest, or valve case, the same entry ports leading to the steam cylinder, and the surfaces of the piston valve perform the same office of closing the entry ports leading to the steam cylinder, as the walls of the slide valve do. The body of the piston valve is cut away in the centre, this forming a hollow, corresponding to the hollow space formed by the ordinary slide valve. The action of the valve is exactly the same. Assuming the valve to be in its central position, when both entry ports are closed by the larger portion of the piston valve at each end, and suppose the valve to move upwards, the entry port leading

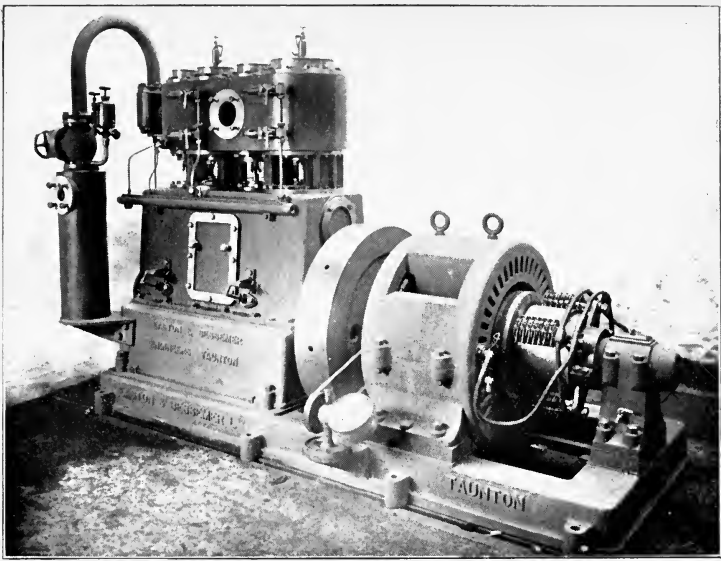

PLATE 15C.—Vertical Compound Enclosed Engine, with Steam Separator, and driving a Dynamo, made by Easton & Bessemer.

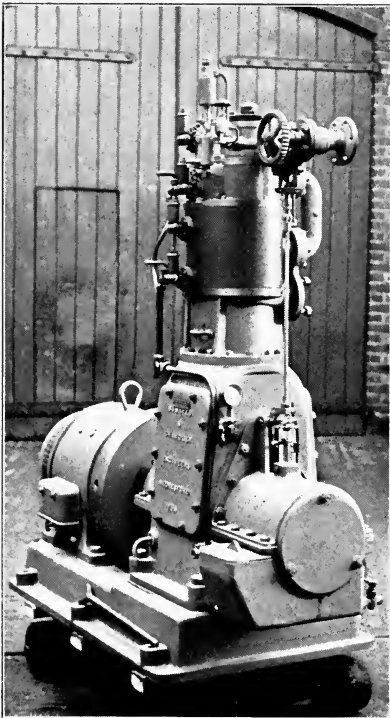

PLATE 16A.—Bumsted Single Cylinder Vertical Encased Engine, driving a Dynamo.  
[To face p. 248.]





to the lower part of the steam cylinder will gradually be uncovered, steam entering the steam cylinder from the steam chest, through it, and driving the piston upwards. At the same time a portion of the hollow space in the centre of the piston valve will come opposite the upper entry port of the steam cylinder, and the steam will flow out from the upper part of the cylinder into the hollow space, and thence to the exhaust. At a certain portion of the stroke, as with the slide valve, the piston valve will commence to move downwards, gradually closing the lower entry port of the steam cylinder, and gradually closing the opening between the upper entry port and the exhaust. As the valve continues to move downwards, the upper entry port will be gradually opened in the steam chest, and the lower entry port to the hollow space in the middle of the piston valve, and to the exhaust, and so on.

The piston valve receives motion from the crank shaft by means of rods worked by eccentrics, just as the slide valve does.

It will be seen that with this form of valve there is not so much danger of leakage of steam past the valve into the exhaust, and it is more commonly employed for high pressures, while there is also not the same pressure forcing it against the surface of the cylinder as in the ordinary slide valve. Several forms of high-speed engines use this valve.

## Drop Valves

The drop valve, one form of which is shown in section in Fig. 103, has been adopted by Messrs. Robey, Messrs. Marshall, and others, for some of their engines. The valve which is shown at A in the drawing is in equilibrium, that is to say, the pressure of the steam is the same on each side of it, and it is arranged for the steam to pass into the cylinder when the valve is lifted. Attached to the engine is an arm shown with an eccentric on it, taking motion by bevelled gear from the crank shaft, and working the eccentric rod K, which gears with a rod marked B in the drawing, pivoted as shown, the other end of which engages with the vertical rod supporting the valve. As the eccentric moves round, the eccentric rod K describes an arc, in the course of which it depresses the end of the lever B, raising the rod attached to the valve rod, and opening it, the steam then entering the cylinder. As the eccentric rod moves on, as the stroke proceeds, the tripping gear attached to the end of the rod is disengaged from the lever B, and the spring above the valve A immediately closes it. It is arranged that the eccentric rod shall engage with the lever B, just before the commencement of the stroke, and the disengagement is controlled either by the governor, or by screws provided for the purpose. Fig. 103 also shows the same valve

arranged for the exhaust, a second eccentric rod being carried as shown below the other one, and opening the exhaust valve in the lower part of the cylinder, through which the steam passes to

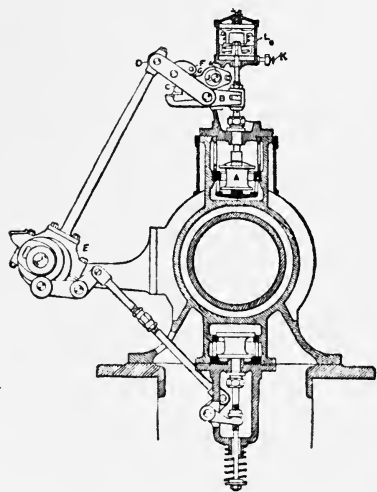

FIG. 103.—Transverse Section of Cylinder with Drop Valve, with Trip Gear, as made by Messrs. Marshall.

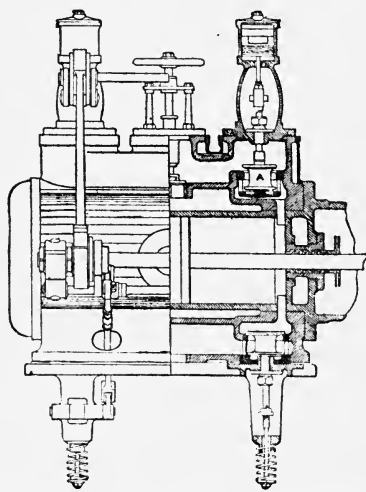

FIG. 104.—Longitudinal of Cylinder, with Drop Valves and Trip Gear for Steam Entry and Exhaust.

the exhaust pipe and to the condenser, etc. It will be seen by the drawing in Fig. 104, showing a complete cylinder, that there are drop valves for each side of the piston for entry, and also for exhaust. Plate 17B is a view of a cylinder fitted with trip gear and the governor.

## The Piston Drop Valves

The piston drop valve, made by Messrs. Collyer, Marchent, and Morley of Bradford, is worked in a similar manner to the drop valves previously described, but the body of the valve is a solid cylinder, and not of the usual mushroom form employed.

## Cornish Valves

The Cornish valve is really a drop valve. It is very much used in winding engines for mines, and was also used in the old Cornish pumping engines. It is an equilibrium valve, like the drop valves described. The valve is usually fixed in its own valve box, forming

part of the engine casting, and is lifted by a lever, worked by the eccentric rod from the crank shaft, it being lifted off its seat at the proper moment, and dropped back and forced into its seat at the point of cut off by weights fixed on the valve rod above.

## The Corliss Valve

The Corliss valve, which is an American design, is in the form of a hollow cylinder, but in place of rising and falling in a port

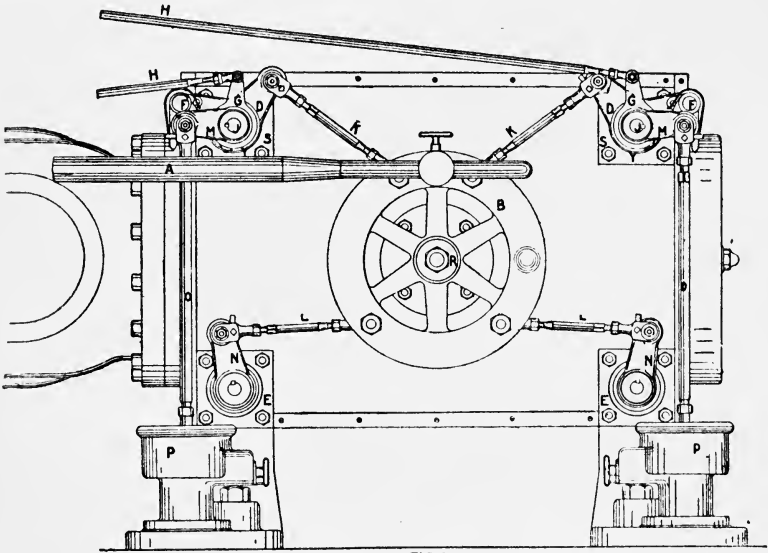

FIG. 1

FIG. 105.—Arrangement of Corliss Valves, with Wrist Plate, as made by the Fulton Co. of America. **S S** are the Chambers for Steam Entry; **E E** those for Exhaust; **B** is the Wrist Plate; **K K** and **L L** the Levers transmitting Motion from it to the Levers **D D**, **N N** which move the Valves; **A** is the eccentric Rod moving the Wrist Plate; **H H** are Rods connected with the Governors actuating the cut off; **P P** are Dash Pots.

provided for it, it revolves within the port. Fig. 105 shows the arrangement of the valve. The valve is usually fitted to horizontal engines, and that there are four such valves placed around the cylinder, and worked by the system of rods shown, from the crank shaft. The cylinders forming the valves have portions cut away, and the casting forming the side of the cylinder, in which the valves work, has ports leading from the steam chest to the steam cylinder, and when a space in the valve is opposite to two spaces in the cylindrical aperture in which it works, steam passes

through it, from the steam chest to the cylinder. Fig. 106 is a sectional drawing of a single cylinder engine with Corliss valves, in which the forms of the valves are clearly shown. Again, when portions cut away in the valve are opposite the entry port to the cylinder, and a port leading to the exhaust, the steam passes through the valve from the cylinder to the exhaust pipe. The valve is rotated as shown by rods from the crank shaft, and is usually brought back by springs. It will be understood that the time during which steam is admitted to the cylinder on either side of the piston, can be controlled by the time during which the cut away portions in the valves are opposite the passages leading to the steam cylinder, and this is controlled by devices to be explained. The four valves are worked by four rods from a disc known as a wrist plate, which is

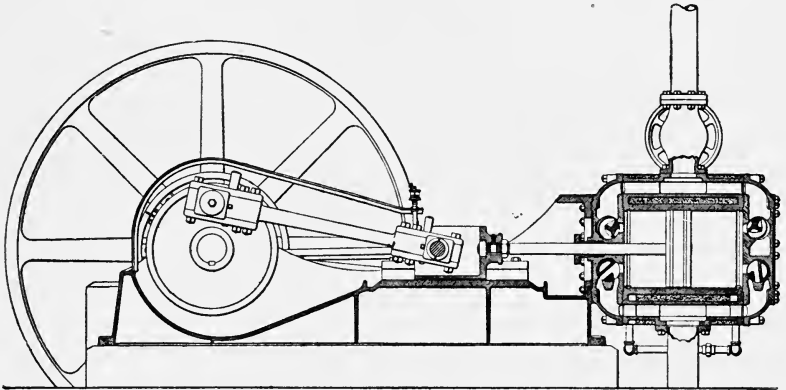

Fig. 106.—Section of Single Cylinder Engine, with Corliss Valves, made by the Atlas Co. The form of the Entry and Exhaust Valves are clearly shown.

pivoted, as shown in Fig. 105, on the side of the engine cylinder, to which the four rods are attached, and a rod leading to an eccentric on the crank shaft. The eccentric rod moves the wrist plate to and fro upon its central pivot, and the plate moves the rods to and fro in their order, the rods moving the valves. Assuming the piston to be at the left of the cylinder, the entry valve at the top left-hand corner is opened by its rod, remaining open for a certain time, and is then closed, and at the end of the stroke, or slightly before, or again a little after, as may be arranged, the valve on the lower left-hand corner is opened by its rod, the steam passing into the cylinder when the upper valve is opened, during the time it remains open, and passing out to the exhaust when the lower valve is opened. When the piston arrives at the right-hand end of the cylinder, or a little before, as may be arranged, the entry valve at the right-hand top

corner is opened, steam passing into the cylinder, the exhaust valve at the right-hand lower corner being opened at the end of the stroke, and so on, these motions corresponding to the motions of the slide valve. The working of the valves themselves, by the rods from the wrist plate, is not quite so simple. The steam entry valves are also under the control of the governor, as shown in Fig. 105, being allowed to remain open a longer or shorter time as with the slide. The Corliss valve is liked because it enables economical steam working to be

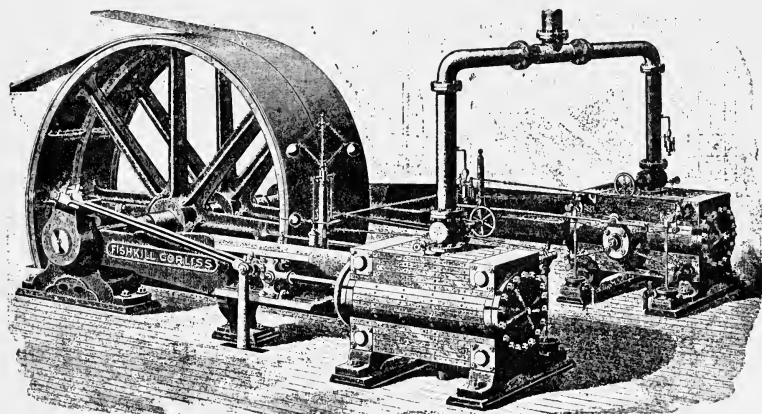

FIG. 107.—Double Cylinder Corliss Engine, made by the Fishkill Co., of America.

obtained, there being little friction, compared with the slide valve, and smaller chance of leakage, since the entry and exhaust valves are not together. Fig. 107 shows a double cylinder, and Plate 15B a single cylinder Corliss engine.

### The Hill or Wheelock Valve

The Hill or Wheelock valve, which is made by Messrs. Adamson in this country, comes to us from America, and it is claimed to have certain advantages over the Corliss valve, which it resembles in some features. Two types of the valves are made, known respectively as A and B. Both types of valves are fixed in castings provided for them, forming the steam chests for the cylinders. Type A is slightly conical, and works in a bore of the same shape, in the casting provided for it. It is suspended on trunnions, and has a semi-rotating movement, something on the lines of the Corliss valve, motion being given to it by an eccentric rod. In type A there is a valve for the entrance of the steam to each side of the cylinder, and another valve for the egress of the steam, but both are worked by one eccentric, the exhaust

valve spindles being connected directly to it, and the entry valve spindles being worked from the exhaust valve spindles, by latch links.

In the type B valve, the exhaust and entry valves are in one. The arrangement is similar to that of type A, up to a certain point, the valves being fixed in the casting below the cylinder, as shown in Fig. 100, and being slightly conical, and working in bores of similar form in the casting. The inside of the valves, however, are flat grid-irons, one for the exhaust and one for the entry, each coming opposite to its proper port at the proper time, the whole being worked by an eccentric rod from the crank shaft.

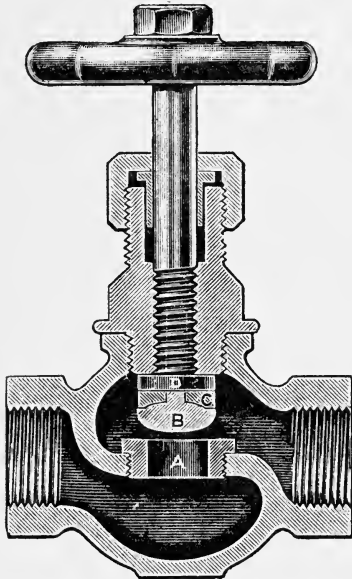

FIG. 108.—One form of Stop Valve, made by W. H. Willcox, which shows the principle of the apparatus very clearly. The Valve would be inserted between the Pipe leading to the Steam Chest and that coming from the Boiler. Steam enters from the Boiler, through the aperture on the left, and when the Valve is open, passes up through the Valve Seat **A**, and out to the right, to the Engine. When the portion **B** is forced down on to **A**, the passage of Steam is prevented, and its flow can be regulated by leaving **B** closer to or farther from **A**. In this Valve **B** and **A** are renewable.

## Stop Valves

The stop valve is the entry valve, allowing the steam to pass from the steam pipe, through which it arrives from the boiler, into the steam chest of the engine, and also for admitting the steam from the boiler to the steam pipe. The stop valve is usually a casting of one of the forms shown, with flanges for bolting to a corresponding flange on the steam pipe, and another on the steam inlet port of the engine, or the outlet port of the boiler, and it contains a space, sometimes spherical, sometimes elliptical, and of other forms, in which the valve mechanism moves. The casting, as a whole, is merely a continuation of the steam pipe. It is a passage for the steam from the pipe into the engine, and it is provided with some

arrangement by which a barrier can be introduced in the path of the steam, wholly or partially preventing its passage. Fig. 108 shows the action very clearly. In the sectional drawings, shown in Figs. 109 and 110, of valves made by Messrs. Alley & Maclellan, Fig. 109 is a stop valve with equilibrium moving member, and Fig. 110 is a

throttle valve on something the same lines. The moving member in the throttle valve is actuated by a rod from the governor, instead of by hand. There are two forms of valves, known as the globe and the angle. In the globe valve, projections are made on the inside of the casting, from the bottom of the inlet and the top of the outlet, the two having a space between them, in which a circular casting called the valve seat is fixed, and the valve itself moves up and down in the valve seat. When the valve is closed down, as shown in Figs. 109 and 110, the steam cannot pass through. The valve is lifted by the hand wheel shown at the top, which will be familiar to every user of an engine, and to every one who has seen an engine. When

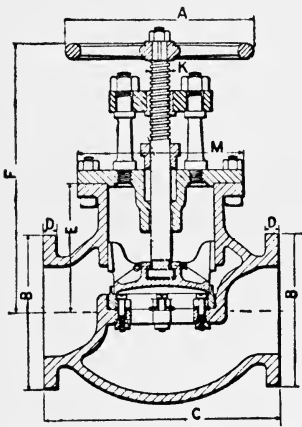

FIG. 109.—Section of a Stop Valve made by Messrs. Alley & Maclellan. The moving portion is of the equilibrium type. Steam passes from one side of the Valve to the other when the moving member is raised.

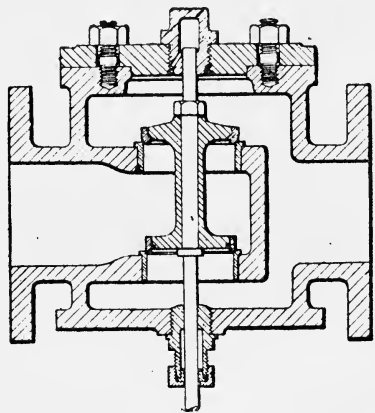

FIG. 110.—Section of Throttle Valve with equilibrium moving member, made by Messrs. Alley & Maclellan.

the hand wheel is turned, the screw shown in the drawing lifts the valve off its seat, and the steam is allowed to pass through, in proportion to the space provided for it. In the angle valve, the valve seat is fixed in the entry port of the casting, the steam turning at right angles, as it passes through the valve, the other arrangements being the same.

The stop valve may be fixed in any convenient position, and is always arranged so that the engine man can handle the wheel conveniently. A favourite position is, the valve casting being fixed vertically, and the wheel standing out at the rear of the engine.

The stop valve is often made of the equilibrium type, as in

Figs. 109 and 110, that is to say, the valve is in two halves, so that there is no pressure of the steam keeping the valve closed, and therefore there is no difficulty in opening and closing it.

The valve body is usually of cast iron, and the valve seat of gun-metal. It is complained that with the usual arrangement in which the valve seat is driven into a recess in the cast-iron body of the valve, unequal expansion and contraction with the different ranges of temperature to which the apparatus is exposed, lead to leakage of the steam through the valve, and this has led to the design of several forms of valves arranged to overcome the difficulty.

As mentioned also, in a previous portion of the chapter, the parts of the stop valves themselves should be warmed up before the valve is put in operation, so that condensation shall not take place in the valve, or the steam pipe beyond it.

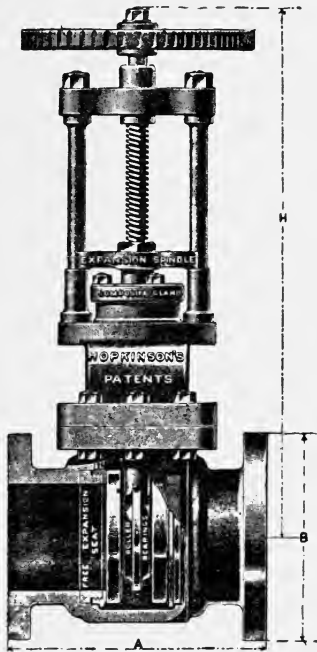

Fig. 111. — Hopkinson's Parallel Slide Stop Valve.

## The Parallel Slide Stop Valve

One of the forms designed to overcome the defects of the ordinary stop valve is the parallel slide stop valve, made by Messrs. Hopkinson & Co., of Huddersfield, as shown in Fig. 111. The arrangement is claimed to be a considerable advance upon the ordinary stop valve, and it is also claimed that all sources of leakage from unequal expansion have been eliminated. There are two valve seats, as will be seen, one on each side of the pipe

forming the bore of the valve, the valve seats being specially arranged so that they are free to expand, without creating leakage. The valve is closed by the central portion sliding in between the two valve seats, and completely filling up the steam way. The moving portion of the valve consists of two discs, forced outwards from each other by strong springs, the discs moving over the faces of the valve seats, on roller bearings. The valve, as a whole, is drawn back bodily, parallel with the valve seats, into the space shown above in the drawing, provided for it, by the usual wheel and screw, as shown. When the valve is to be closed, it is forced forward in



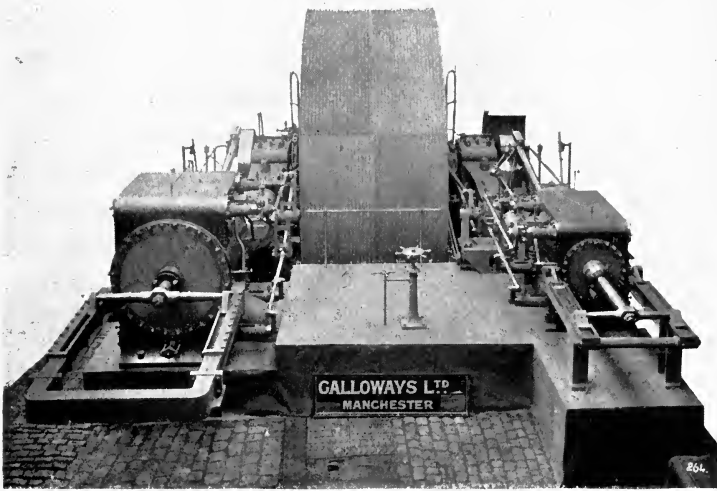

PLATE 17A.—Horizontal Cross-compound Engine, with Rope Drive, for Lancashire Mills.

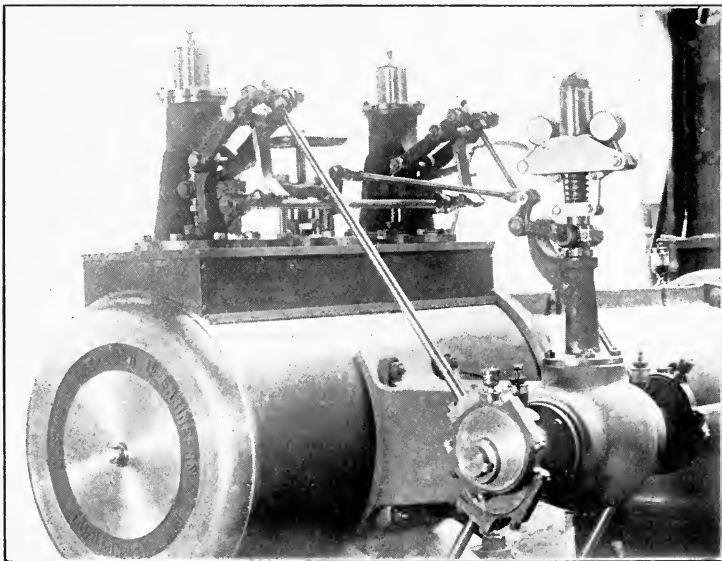

PLATE 17B.—Trip-valve Gear and Governor, made by Easton & Bessemer.  
[To face p. 256.]



the same way. It is claimed, in addition to the absence of leakage mentioned, that when the valve is wide open, there is a full bore for the steam, equal to the steam pipe, unchecked by any projections, such as those employed in the usual form of stop valve. When the valve is partially open, the passage for steam is crescent shaped. In addition to the valve seats being arranged to prevent leakage, the stuffing box or gland of the valve is also specially constructed, to provide against leakage. The passage through the top of the valve box is bored to a conical form for a short distance, as shown, and then the usual cylindrical form is resumed. The conical portion is filled with a bush of a special material, which is claimed to resist the action of water and high-pressure steam. The space immediately above it is filled with a preparation of asbestos and plumbago, the whole being closed by the metallic gland. The screw spindle which operates the valve, is also made on the well-known compensation principle, by which variations of temperature are provided for.

A modification of the parallel slide stop valve is the Hopkinson-Ferranti valve, in which the inlet and outlet portions of the valve are coned, the valve itself being fixed in a throat between the two cones. The steam enters the valve through a converging nozzle, passing into the valve with a high velocity, and passing out through a diverging nozzle, in which the velocity is lowered to the normal.

### Centre Pressure Stop Valve

Another form of valve made by Messrs. Hopkinson, which it is claimed accomplishes practically the same object, is shown in section in Figs. 112, 113, and 114, the figure on the left showing the valve shut, that in the middle showing it partially opened, and that on the right fully opened. In this form of valve there is a casting very similar to that of the ordinary stop valve, with two projections, one from the lower portion, and the other from the upper portion, having the cylindrical space between them, as in the ordinary form of valve; and in this cylindrical space two distinct valve seats are fixed, on the lines of the valve seats described in connection with the parallel slide valve. The moving portion of the valve is in two parts, one moving upwards in closing in the lower space, and coming against the lower portion of the lower valve seat; and the other moving downwards in closing, and coming against the upper portion of the upper valve seat. The two valves are separately controlled by the system of spindles shown above the valve casing, both of them being worked by the wheel and screw, in the usual way. The upper valve is the main valve, and it is always opened

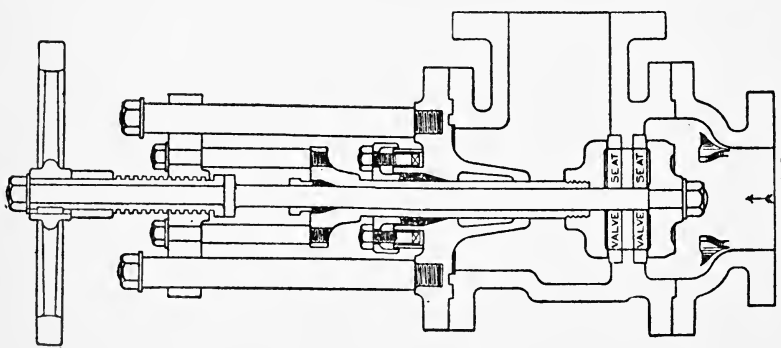

FIGURE 112.

Shut Position, showing lower valve held to its seat by boiler pressure.

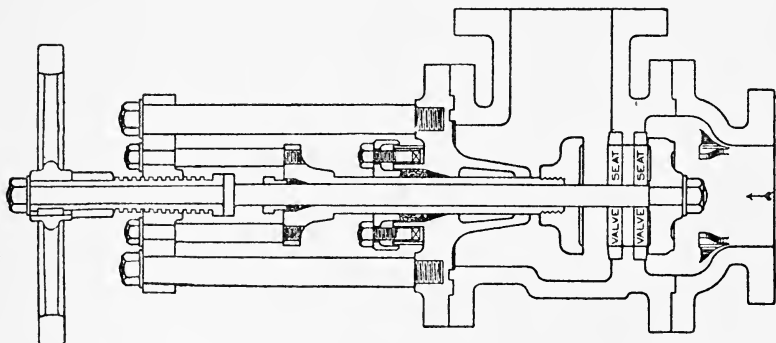

FIGURE 113.

Opening Position, shewing method of protecting the main valve and seat.

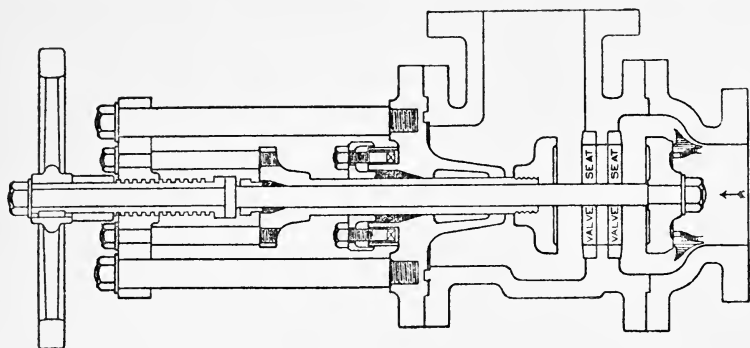

FIGURE 114.

Full open, for passage of steam.

Figs. 112, 113, 114, showing Hopkinson's Centre Pressure Valve, shut, partly open, and full open.

first, and closed last. When the valve is to be opened, the upper valve is raised from its seat, as shown in the middle drawing, the lower valve still preventing the passage of steam through. When the upper valve has been fully opened, the lower valve is lowered, as shown in the figure on the right, and the steam then passes freely through. When the valve is to be closed, the lower valve is first drawn up to its seat, thus shutting off the steam, the main valve then not having the steam pressure against it, is easily closed. The double action is obtained by the aid of the floating bridge above, which is

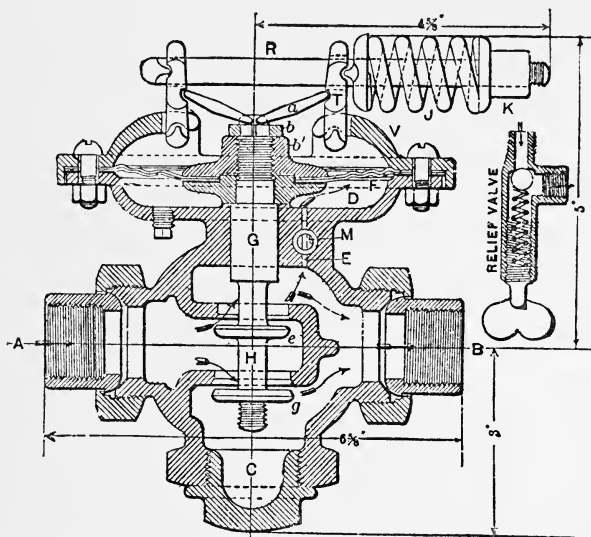

FIG. 115.—Valve made by Messrs. W. H. Bailey & Co. for reducing the pressure of Steam, from that of the service, to what the Engine, or other apparatus, can conveniently handle. The Steam is throttled in passing through the Valve, issuing at a lower pressure.

drawn upwards when the hand wheel is turned counter clockwise, and which draws up the carrier attached to the main valve. When the main valve is fully opened, the floating bridge engages with stops provided for it, and then becomes a fixed nut, the screw revolving in it, and the central spindle which is attached to the lower valve, then moving the latter downwards, the reverse operation taking place when the valve is to be moved upwards. Another valve that is useful at times is the reducing valve, one form of which is shown in Fig. 115. It enables steam to be taken from a high-pressure service and used in low-pressure apparatus.

## Taking the Power from the Piston

It has been explained that the energy delivered to the water in the boiler is delivered by the steam that is formed from the water to the moving pistons, in the cylinders of reciprocating engines. The next problem is, the delivery of the power from the piston to the machine or apparatus that is to be worked. In the early Cornish pumping engines, the arrangement was a very simple one, the steam cylinder stood under one end of a long lever, and the pump stood under the other end. A rod, or system of rods, connected the piston with one end of the lever or beam, and another rod or system of rods connected the other end of the beam with the pump buckets. As the piston moved upwards in the cylinder, it forced that end of the beam up, the opposite end being depressed, and driving the pump buckets down into the pump in the suction stroke. When the piston descended, as explained in a previous part of the book, when the steam underneath it was condensed, it pulled down the end of the beam above it, the opposite end ascending, and pulling up the pump buckets, with their load of water, and delivering it to the delivery pipe. With this arrangement a certain amount of play is necessary between the ends of the pump rods and the beam, and also between the end of the rods connecting the piston with the beam. This play is provided for by a loose joint, allowing the ends of the rods to move round the ends of the lever.

For a large portion of the work of the steam engine, however, it is necessary to convert the to and fro motion of the piston into rotary motion, and this is done by the aid of a crank shaft and connecting rods. In a great many instances, power is conveniently taken from a continuously revolving shaft, such as a crank shaft, and is converted to to and fro motion, where required, in the machine to be driven, by other mechanism; but for a great many purposes, and particularly with the modern tendency to electrical driving, rotary motion is the most convenient. Rotary motion is obtained from the to-and-fro motion of the piston, by attaching to the end of the piston rod a second rod, called the connecting rod, by a loose joint, and attaching the other end of the connecting rod to the apparatus known as a crank. The piston rod is attached rigidly to the centre of the piston, and moves through a gland or stuffing box in the end of the cylinder, and is made only sufficiently long to project outside of the cylinder, when the piston is at the opposite end of the stroke. The crank consists really of two radii of a circle, connected together by a cross piece, the two radii being attached to the two portions of the shaft to which the crank is to give motion. In some smaller engines the crank is displaced by a disc, the connecting rod being

attached to a point of the disc, near its periphery. When the piston is at the commencement of its stroke, and is at the end of the cylinder farthest from the crank shaft, the crank, connecting rod, and piston rod, are all in one line. As the piston moves forward, the piston rod pushes the connecting rod forward, and as the only way in which the connecting rod can move is upwards, it takes a position in which the two radii forming the two sides of the crank are slightly inclined to the horizontal. As the piston moves forward, the piston rod moves on, the connecting rod following, and the two sides of the crank shaft making a gradually increasing angle with the horizontal. At half stroke the two sides of the crank shaft make an angle of  $90^\circ$  with the horizontal; and as the piston and connecting rod move still further forward, the sides of the crank shaft commence to decrease the angle with the horizontal on the other side, till at the end of the stroke, the crank is again in the horizontal position, and the piston rod, connecting rod, and crank shaft, are again in one line. The two points when the piston rod, connecting rod, and crank, are in one line, are called the dead points, and it is the rule, whenever an engine is stopped, that the piston should not be left in the position in which the crank is on either of its dead points. It should be as near the intermediate position, where the crank is at an angle of  $90^\circ$ , as possible.

It will be seen that the linear distance through which the crank pin—as the cross piece connecting the two radii of the crank is called—travels, is the same as that through which the piston travels. In fact, when it is required to know the stroke of an engine, it may be measured by measuring the length of the radii of the crank, and doubling it.

With double-cylinder engines—whether they are twin simple cylinders, or compound—it is usual to arrange the cranks either  $90^\circ$  apart on the crank shaft, or  $180^\circ$ . There are the usual differences of opinion as to the advantages of the two positions. When the crank shafts are  $90^\circ$  apart, it is impossible that both engines can be on their dead points together, and therefore there is no difficulty in starting. On the other hand, where the crank shafts are  $180^\circ$  apart, the turning effort is delivered more uniformly to the crank shaft.

With three cylinders, as in triple-expansion engines, the crank shafts are arranged  $120^\circ$  degrees apart, and it will be seen that there must always be one engine at least in a position to commence the turning movement of the shaft, while the turning effort is more evenly distributed through the revolution.

The crank shaft receives the power from all the pistons forming one engine, no matter how they may be arranged. Even in those cases where the engine cylinders are arranged one above the other, or one behind the other, the effort of all the cylinders is delivered to

the crank shaft, and the crank shaft is the source of power for everything that is worked by the engine, including its own valves, governor, etc. As already explained, the admission and exhaust valves of the engine are always worked by eccentrics, and these take their motion from the crank shaft. Other valves take their motion indirectly from the crank shaft, by means of rods working bevelled gear, which operate trip mechanisms at proper intervals, but again it is the crank shaft from which the motion emanates.

Again, it is the crank shaft from which power is taken to drive the machines or apparatus the engine is to work, and this may be done by directly connecting the end of the crank shaft with the end of the shaft of the machine to be driven, as in the case of direct-driven electricity generators, or the power may be taken from the crank shaft to the apparatus to be driven, by the aid of gearing, as in the case of winding and hauling engines for mines, and other apparatus. In these cases the end of the crank shaft may carry either the pinion of a system of spur and pinion wheels, where the speed of the driven machine is to be less than that of the driving engine, or it may carry the spur wheel, where the speed of the driven machine is to be greater; and, again, it may carry worm gearing with a wheel on the shaft of the driving machine, where worm and wheel driving is employed.

The power may also be taken from the crank shaft by the aid of belts or ropes. In these cases a pulley is fixed on the end of the crank shaft, and one of similar width on the end of the shaft of the machine to be driven, and the diameters of the two pulleys must be in the proportion of the speeds of the driven machine, to that of the engine. Thus, if the engine is running at 400 revolutions per minute, and the driven machine is to run at 100 revolutions, the pulley on the crank shaft of the engine must be one quarter the diameter of that on the driven machine. On the other hand, if the engine is running at 100 revolutions, and the machine is to run at 400, the diameter of the pulley on the end of the crank shaft of the engine will be four times that of the pulley on the driven machine.

Pulleys for belt driving are merely hollow cylinders, with a bush of the size of the shaft on which they are to be fixed, their surfaces being smooth all over, and slightly rounded towards the edges. They may be fixed to the shafts to which they are attached by keys driven in between the shaft and the boss of the pulley, or by screws holding them. The power is transmitted from the crank shaft of the engine to the shaft of the driven machine, by friction between the belt and the two pulleys. The friction between the pulley on the crank shaft and the belt lying on its surface, causes the belt to move in the direction in which the crank shaft is revolving, the rotary motion of the pulley being converted into linear motion in the belt, each portion



of the belt travelling from the pulley on the crank shaft to the pulley on the driven machine, and back again. On the driven machine, the friction between the belt and the pulley causes the surface of the pulley to turn in the direction in which the belt is running, this causing rotary motion of the pulley and of the shaft to which it is attached, and of anything the shaft is driving. There is always a tight side of a belt and a loose side. With many machines it is better practice to have the tight side of the belt the lower one. That is to say, the belt travels from the under side of the pulley of the machine to be driven to the under side of the pulley on the crank shaft of the engine, that piece of the belt which is between the two pulleys transmitting the power from the engine to the machine, the remainder of the belt merely acting to bring successive portions of the belt into the driving position. Where the lower side of the belt is the driving or tight side, the tendency of the pull is to keep the driven machine down on to its foundations, and in addition, the weight of the loose portion of the belt, lying over the two pulleys on the non-driving side, adds to the grip of the belt on the pulleys, and improves the drive.

If a belt is wet, or if it is not equal to the power it is intended to transmit, it is very apt to slip, and then the speed of the driven machine is less than it should be, according to the proportions of the two pulleys, and the speed of the driving engine. A belt will also slip with a badly made joint, and if it is not sufficiently tight between the two pulleys. When slipping occurs, it will be known by the heating of the pulleys over which it runs, and, in particular, that of the smaller pulley. When a belt is running properly, and transmitting power as it should do, there is no appreciable heating, either of the belt or of either of the pulleys; but immediately slipping commences, the additional friction between the belt and the surfaces of the pulleys causes heating which may easily be observed. As a temporary measure, where a belt is slipping, resin thrown between the belt and the pulley will get over the trouble, but the source should be sought immediately the opportunity offers.

There is a certain size belt for a certain quantity of power delivered, with a certain speed, and this is given from the formulæ—

$$\text{H.P.} = \frac{(T - t)V}{33,000}$$

This gives the H.P. any belt will deliver at any velocity,  $T$  being the strain in pounds on the tight side of the belt,  $t$  that on the slack side, and  $V$  the speed of the belt in feet per minute.  $t$  is usually taken as half  $T$ , as an average, and single belts will stand from 60 to 120 lbs. per square inch, double belts 135 to 160 lbs., so that taking an average the formulæ for the size of a single belt becomes—

$$W = \frac{33,000 \times \text{H.P.}}{45 \times V}$$

and for a double belt—

$$W = \frac{33,000 \times \text{H.P.}}{75 \times V}$$

W being the width of the belt in inches in each case, and 45 lbs. and 75 lbs. the average values of  $T - t$ .

When rope driving is employed, the surfaces of both the driving and driven pulleys are grooved out, and a number of ropes from two upwards, according to the power to be transmitted, are laid in the grooves, between the pulleys, very much as the belts are. There are two methods of arranging rope driving. In one a single rope is employed, carried continuously round all the pulleys, but this method is now very rarely seen. In the other method, which is most frequently employed, there are as many endless ropes as there are grooves on the pulleys, the sizes of the ropes varying from  $2\frac{1}{2}$  inches circumference to  $6\frac{1}{4}$  inches circumference. Ropes are measured by their circumference, but it is always easy to reduce them to approximate diameters by dividing the circumference by three. Thus a 3-inch rope is approximately 1 inch in diameter. It will be remembered that the circumference is  $3\frac{1}{2}$  times the diameter nearly.

Each rope takes a portion of the load, and the power is transmitted from the driving to the driven pulleys by friction between the ropes and the pulleys, just as by belts. A complaint is frequently made against ropes, that the individual ropes rarely take their proper share of the load, sometimes one rope having more than the others, and again, the one that has been taking the heavier load, losing a portion of it, and so on. This, it appears to the author, is strictly true in all but very rare instances. If a system of driving by ropes be examined, it will always be seen that some of the ropes are tighter than others, and these are taking the major portion of the load. It is, the author believes, almost impossible to ensure that each rope shall take its own share of the load, no more no less at all times; but the remedy for any trouble that may arise, appears to be the old one—to have more ropes than would be necessary if it could be ensured that all of them take their proper share of the load, and then the action appears to be as follows. Some of the ropes take more than their share of the load for a certain time, and become gradually elongated in consequence, and then the other ropes that have not been subject to so much strain, gradually assume the load, those which took it in the first instance being gradually released. The ropes which take the load after the first lot have stretched become stretched in their turn, others take it up, and so on, the whole of the ropes really taking their share of the work in

turn in this manner, but it being necessary that the individual ropes shall be stronger than would be necessary if all took their proper share of the load.

It is stated also that the efficiency of the rope drive is very low, as low as 90 per cent., while belt drive is as high as 98 per cent., and spur gearing the same. On the other hand, rope driving has the great advantage of being very smooth, and very silent, and if a little power is wasted in transmitting the energy, the increased cost of coal is probably made up in other directions. The formula given shows the sizes of rope for transmitting any given power.

$$\text{H.P.} = \frac{\text{NPV}}{33,000}$$

where N is the number of ropes, P the driving force in pounds, V the speed of the ropes in feet per minute.  $P$  (the driving force) =  $C^2 \times x$ , where C is the circumference of the rope and  $x = 6.6$  for horizontal, 3.3 vertical, and 9.4 for ropes at an angle of  $45^\circ$  (Kemp).

Worm-and-wheel driving was, up till recently, very inefficient, but with the advance of manufactures, and in particular with the advance in the working of machine tools, and with better understanding of the problem, the efficiency of worm gearing has been considerably increased within recent years. Worm gearing is claimed now to have efficiencies up to 90 per cent., and it is perhaps one of the most convenient methods of transmitting power, where a great reduction of speed is required, that is available.

## The Government of Engines

There are broadly two forms of engine governors, known respectively as the throttle governor and the expansion governor. Both are worked either directly or indirectly from the crank shaft. The governor always consists of a pair of steel balls, attached to a central rod around which they revolve, when they receive motion from the crank shaft, and they are arranged to give motion to the rod around which they move, so as to either close or open a valve, or to decrease or increase the time during which a valve is open. The throttle governor, as explained previously, always acts upon the valve controlling the supply of steam to the steam chest. A common

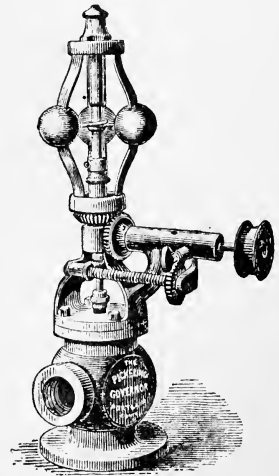

FIG. 116.—Pickering Governor.

form of it is shown in Fig. 116. It is one that is employed principally for small engines, but it illustrates the principle of the apparatus very clearly. It is known as the Pickering governor. It will be seen that it is mounted on the top of the box containing the stop valve, which is arranged to be fixed between the steam supply pipe and the steam chest. A vertical spindle rises from the top of the valve box, and carries at its head three flat springs, on which are three steel balls,

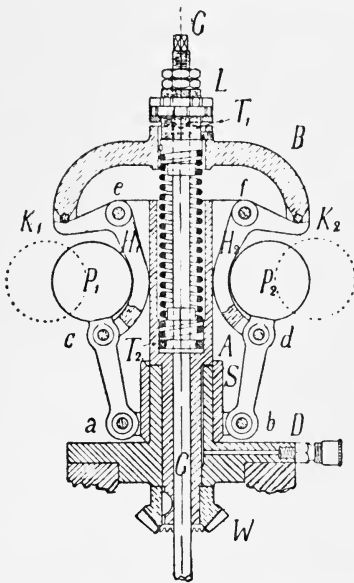

FIG. 117.—Section of Proell's Governor, made by Messrs. Isaac Storey.  $P_1$   $P_2$  are the Governor Balls, held, when at rest, in the Hanging Straps,  $H_1$   $H_2$ .  $G$  is the Valve Spindle, and  $A$  a Tube in which the Spiral Spring is enclosed. When the Engine is working,  $G$  revolves, carrying  $H_1$   $H_2$  and  $P_1$   $P_2$  round.  $P_1$   $P_2$  fly out, forcing  $S$  up and compressing the Spiral.

tending to push the spindle down, and to partially close the valve, decreasing the pressure of the steam in the steam chest. On the other hand, if the speed of the engine is lowered, owing, say, to an increased load, the balls revolving at a lower speed fall inwards towards the spindle, this causing the valve to rise, and to let more steam into the steam chest, increasing the pressure behind the piston. Fig. 117 shows the Proell governor, in

the three springs being also attached at their lower ends, so that they can slide up the spindle. The spindle at its lower end in the box controls the motions of the valve, allowing steam to pass to the steam chest. The valve can also be controlled by the valve wheel, as usual. In other forms of governor there is a spiral spring on the central spindle, against which the balls, as they revolve, have to work. The small pulley shown in the Pickering governor, on which a strap from a pulley on the crank shaft runs, gives motion to the spindle, and through it to the steel balls. As the balls revolve they move outwards by centrifugal force, and as they move out, they tend to depress the central spindle, this tending to close the valve. When the engine is running at its normal speed, the steel balls revolve round the spindle at a certain distance, the flat springs being bent to a certain curve. If the engine increases its speed, as say when the load is decreased, the balls move at an increased speed, and move further outwards, owing to the increased centrifugal force, this

which a spiral spring opposes the centrifugal force of the governor balls.

It has been shown by the exhaustive experiments of Captain Sankey and others, that the throttle valve is only economical under certain conditions, as with very light load, and when the load is beyond a certain proportion of the possible full load. Between these the expansion governor, to be described, more accurately controls the

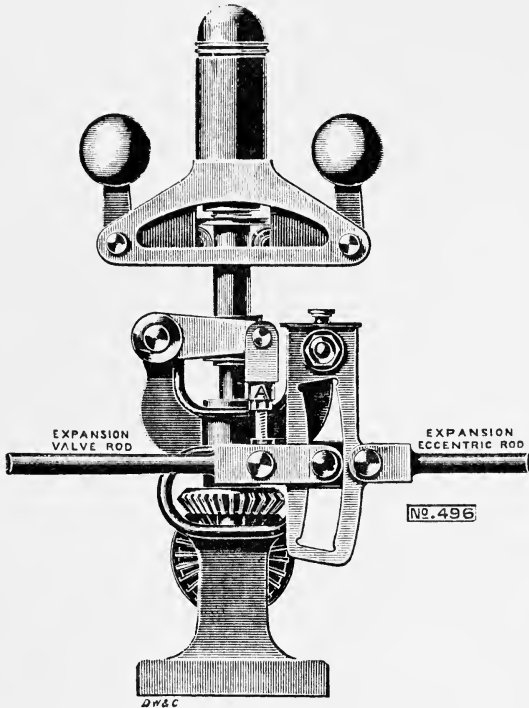

FIG. 118.—Wilson Hartnell's Expansion Governor, made by Messrs. Marshall. The link motion, described on page 247, is seen on the right. The position of the Governor Balls controls the position of the Expansion Valve Rod, with reference to the Eccentric Rod, and through it the time the Slide Valve is open.

supply of steam to the engine, in accordance with the work the engine is doing.

It will be understood that the supply of steam to the engine is controlled, in both cases, after an increase or decrease of load has taken place. The object of the governor is to accurately proportion the supply of steam in the engine to the work the engine is performing. Thus, if the engine is only working at half load, it should only

take a little more than half the steam it would at full load, the increase with the half load being due to the larger proportion which the steam, required to overcome the friction of the engine itself, bears to that required for half the load, than to that required for full load.

Throttle governing differs from expansion governing in that the throttle governor controls the pressure at which the steam enters the steam chest, but does not attempt to control the time during which the entry valve to the steam cylinder is open. The pressure of the steam entering the steam chest is controlled by opening the valve more or less. With the valve partially closed, not so much steam

can pass through, and therefore steam does not enter the steam chest at the same rate, other conditions being the same, and the effect is a lowered pressure. The result of partially closing the valve is the same so far as pressure is concerned, as of interposing a length of steam pipe between the supply pipe and the engine.

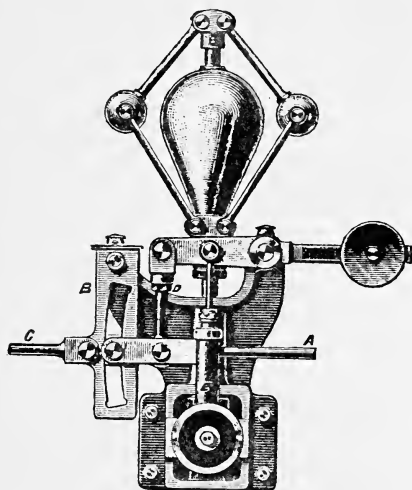

FIG. 119.—Expansion Governor made by Messrs. Coltman. C is the Eccentric Rod; A is the Slide Valve Rod; B is the Arc of the link motion.

In the expansion governor, the pressure of steam entering the steam chest is not controlled at all, but the portion of the stroke during which steam enters the cylinder is controlled according to the load the engine is doing.

In the expansion governor, of which Fig. 118, the governor introduced by Mr. Wilson Hartnell, is a good example,

there is the same pair of balls, though they are usually much heavier than those in the throttle governor for the same sized engine, but the rod, which is much stronger with the throttle governor, is made to control the travel of the slide valve, as shown in Fig. 118. The action of the governor is very similar to that of the throttle governor. It receives motion by means of a strap, or in some cases by a rod and bevel gearing from the crank shaft, and its balls move outwards by centrifugal force, just as the throttle governor's balls do, and it moves its vertical rod more or less as the balls move out or in, these again moving in accordance with the increase or decrease of speed of the engine, but the motion of the rod controls the position of the valve

rod controlling the travel of the slide with reference to the eccentric rod, by moving the arc of the link motion. With increased speed of the engine, the travel of the slide is reduced, the steam only entering the cylinder for a smaller portion of the stroke, and with decreased speed of the engine the travel of the slide is increased, giving steam for a longer portion of the stroke. Fig. 119 shows another form

of expansion governor, by Messrs. H. Coltman, in which the action of the governor on the link motion is very clearly shown.

Both expansion and throttle governors are often fixed directly on the crank shaft itself. In those cases there is usually a disc

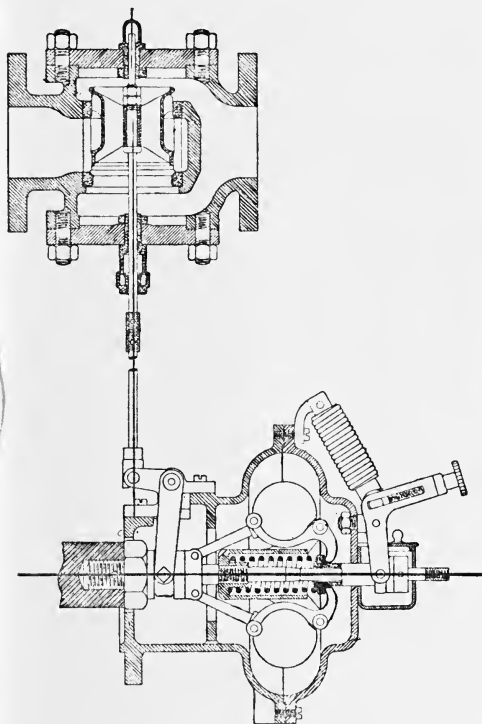

FIG. 120.—Proell Governor, made by Messrs. Isaac Storey, fixed on the end of the Crank Shaft, and controlling the Throttle Valve above, by means of the Vertical Rod shown.

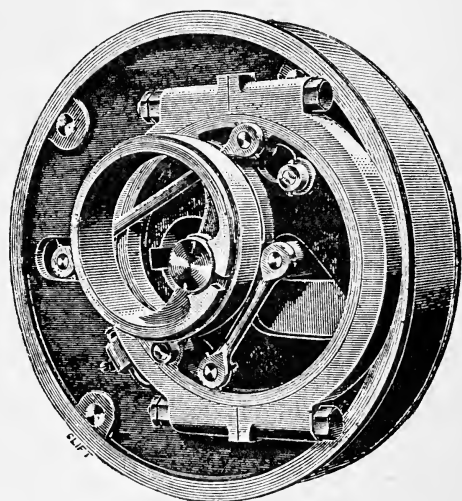

FIG. 121.—Expansion Shaft Governor, made by Messrs. Ransome, Sims, & Co., for High-speed Vertical Engines. The parts of the Governor are enclosed in the Box shown.

carried by the crank shaft, on which the governor balls or their equivalent are mounted, and from which motion is conveyed to the eccentric controlling the slide valve by gearing. In the governor, which is worked in conjunction with the drop valve expansion gear described on page 250, the time during which the eccentric rod K, in Fig. 103, engages with the lever opening the steam entry valve is controlled by the governor in the same manner as in the slide-valve expansion governor. With increased speed the eccentric rod engages

for a shorter time with the valve lever, the valve thence being open for a shorter time, and with decreased speed, the rod being longer in contact. Fig. 120 shows a Proell governor driven from the crank shaft and controlling a throttle valve above. Fig. 120 shows a governor fixed on the end of the crank shaft, and controlling the expansion.

## The Indicator

The indicator is the apparatus employed to find the mean effective pressures in engine cylinders. Fig. 122 shows one form of it, made

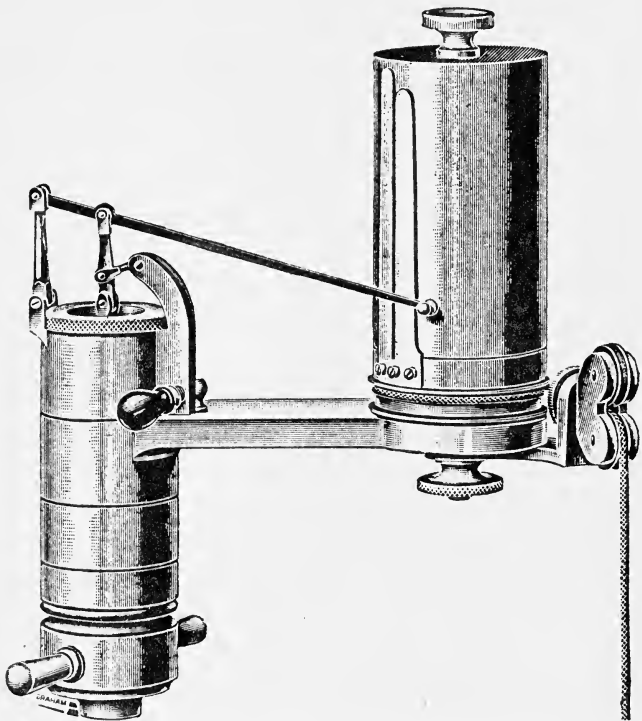

FIG. 122.—Crosby's Steam-engine Indicator. The Cylinder on the left repeats the Steam Pressure in the Engine Cylinder, and that on the right carries the Paper.

by Messrs. Crosby. It consists of a small cylinder with a small piston, and a piston rod inside, and another cylinder arranged to revolve on its axis once in the time occupied by one stroke of the engine that is being indicated, and at exactly the same speed, and the piston



and the cylinder together reproduce what is going on in the engine cylinder, though in a different manner. On the outside of the small revolving cylinder is wrapped a piece of paper, squared for preference, as it renders the measurements easier, and a pencil attached to an arm worked by the piston bears on the surface of the paper. As long as the pressure in the steam indicator cylinder is constant, as when it is open to the atmosphere, the pencil merely runs round the cylinder, making a line that is straight when the paper is unrolled, but when the pressure in the piston in the indicator cylinder varies, the position of the pencil varies in unison with it, the result being a curved and sometimes irregular line. The indicator cylinder is connected by a small steam pipe to the engine cylinder, small cocks being provided in the cylinder walls for the purpose, and when connection is made, the pressure of the steam in the engine cylinder is reproduced in the indicator cylinder. The piston of the indicator cylinder does

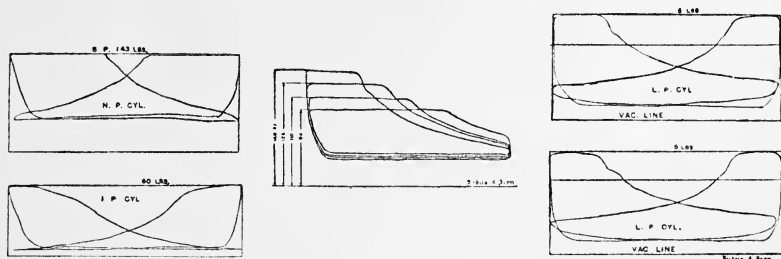

FIG. 123.—Examples of Indicator Cards taken from a Triple-expansion Engine. The Cards show the pressures in the High-pressure, One-pressure, and two Low-pressure Cylinders, also the action of the Cut-off at different parts of the Engine. The Cards in the middle show the pressure, with different Cut-offs.

not move in the same way as the piston of the engine cylinder does. It takes up a position within its own cylinder in accordance with the pressure behind it. The motion of the piston is opposed by a coiled spring on the piston rod, and the motion allowed to the piston is exactly proportional to the pressure exerted by the steam. When an engine is to be indicated, connection is made to the steam space in the engine cylinder behind the piston, and arrangements are also made to revolve the paper carrying cylinder in unison with the motion of the engine piston, usually by a string attached to some moving part of the engine and to the indicator cylinder. The revolution of the indicator cylinder is also opposed by a spring. When all is ready, the engineer first obtains his atmospheric line upon the indicator paper by revolving the cylinder, with the pencil bearing against the paper, and with the indicator cylinder open to the atmosphere. Connection is then made to the engine cylinder, and the apparatus is allowed to

work. The piston is forced outwards in the indicator cylinder when the stroke commences, and gradually recedes as the pressure falls, the pencil making a line upon the paper in accordance with this. The pencil follows pressure behind the piston of the engine right to the end of the stroke, and during the return stroke, the line formed on the paper giving the pressure of the steam inside the cylinder, above or below atmospheric pressure, at each instant. The steam and paper cylinders are in one in the older forms of indicators.

Fig. 123 show indicator cards, as they are called, taken from various engines. In some, it will be seen, the return pressure is

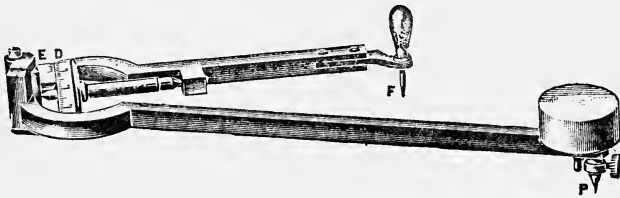

FIG. 124.—One form of Planimeter made by Messrs. Crosby.

below the atmospheric line. This means that the engine was working with a condenser. In others the return stroke shows pressures appreciably above the atmospheric line. This shows back pressures appreciably above the atmosphere. In all cases the mean of all the pressures throughout the stroke is taken, and the result is the figure used in the calculations given on p. 218.

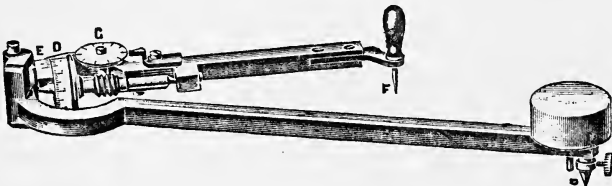

FIG. 125.—Another form of Planimeter made by Messrs. Crosby.

It will be noticed that the first portion of the line representing the pressure is parallel with the atmospheric line. This represents the portion of the stroke during which the cylinder was open to the pressure of the steam chest; and in late cut-offs, it will be seen, the length of this portion is large, compared to the whole stroke, while in early cut-offs it is small. To an expert the indicator tells nearly everything he wants to know about the engine, how it is working, what steam it is using, etc. Figs. 124 and 125 show planimeters, instruments for transferring the curves of indicator cards to larger paper, and measuring the quantities easily and quickly.

## Steam Pipes

Pipes are employed for conveying the steam from the boiler to the engine, and from the engine to the condenser, or to the exhaust. Steam pipes are made usually of wrought iron or steel, and they must be of a certain size in order that they may convey the steam from the boiler to the engine without throttling, and also from the engine to the exhaust. The remarks that have been made about the friction of fluids upon the walls of pipes through which they are passing, apply equally to steam. The passage of steam through steam pipes causes friction upon the walls of the pipe, and in so doing, robs the steam of a portion of the pressure that was delivered to it in the boiler. Further, the friction depends directly upon the surface over which the steam rubs, this depending upon the length of the pipe and the internal surface, and it also depends upon the square of the velocity of the steam. The same thing applies here as has been mentioned before. If the steam is confined in too small a pipe, its velocity is increased, and though the internal surface of the pipe is less than with a larger pipe, the increased friction, owing to the increased velocity, is very much greater. Hence it is of importance that the pipe should be of sufficient diameter to carry the steam without undue friction. The distribution of steam in steam pipes has been compared, not inaptly, to the distribution of electricity by means of cables. Steam has been used for a great many more years than electricity, and therefore it looks a little strange for steam phenomena to be illustrated by the aid of practice in electricity; but the arrangements for distributing electricity are so much simpler, as a rule, than for distributing steam, and have been so much more fully worked out, that the comparison is not at all inapt. On the other hand, it should be noted that the differences between heat and electricity are strongly accentuated in the matter of the distribution of steam, as against that of electricity. The loss of pressure when steam passes through a steam pipe has been compared to the loss of pressure which takes place when an electric current passes through a cable; but although this comparison is strictly correct up to a certain point, it has the very important difference that the energy lost in the conductor, owing to the resistance of the conductor, is actually lost so far as the useful application of the electric current is concerned, while there is no loss of energy due to the friction of the steam in the pipes. If there is a loss of one volt, or five volts in an electrical distribution service, or whatever it may be, there is that much less electrical energy to use for lighting, or power, or whatever the electricity may be employed for. And the reason for this is, that the energy absorbed by the resistance of the electrical

conductor is converted into heat, which not only plays no useful part in the distribution of the current, but actually adds to the resistance of the conductor, and may lead to other troubles, such as deterioration of the insulating envelope. On the other hand, though the friction of the steam on the walls of the steam pipe, and on the steam passages of valves, etc., also generates heat, it involves no loss. It is merely a transference of heat from the steam, in the form of pressure, to heat in the steam pipe and in the steam itself, and it is claimed by steam engineers that the heat so liberated tends to superheat the steam. Put in another way, the energy is lost as pressure, the steam expanding in accordance with the laws given in the first chapter, but the energy is regained in the form of heat delivered to the steam of the lower pressure in the form of superheat. At the same time, it will be understood that there is a limit to the size to which the steam pipes may be reduced, and, as usual, practice has determined it by the velocity of the steam that is found most economical in practice. A velocity of steam of 6000 feet per minute, equal to 100 feet per second, is that usually employed, though in marine work, velocities up to 150 feet per second are often usefully employed. For the first velocity named, 100 feet per second, the loss of pressure has been worked out by Prof. Unwin and others, and is given by—

$$p = 0.04839K \left(1 + \frac{3.6}{D_1}\right) \frac{w^2 L}{D d_1^5}$$

where  $p$  is the loss in pressure of the steam in pounds per square inch due to the friction of the steam through the pipes,  $K$  is the coefficient of friction given as 0.0026 and 0.0027 for steam,  $D$  is the weight of steam per cubic foot,  $d_1$  is the diameter of the pipe in inches,  $w$  is the flow of steam in pounds per minute, and  $L$  is the length of the pipe in feet.

Substituting the value of  $K$ , 0.0027, the formula becomes—

$$p = 0.000131 \left(1 + \frac{3.6}{D_1}\right) \frac{w^2 L}{D d_1^5}$$

And the weight of steam passing with a difference of pressure,  $p$ , between the two ends of any pipe, is given by the formula—

$$w = 87 \left( \frac{p D d_1^5}{\left(1 + \frac{3.6}{D_1}\right)^4} \right)^{\frac{1}{2}}$$

The weight of steam per minute that passes through pipes of given size has been calculated, and is given in the tables on pages 276 and 277, for a loss of pressure in the pipe of 1 lb. per square inch

As will be seen, the figures are given for different sizes of pipes, and for lengths of each pipe equal to 240 diameters of the pipe itself, also with different initial steam pressures.

Elbows in pipes, globe valves, and square-ended entrances to pipes, all offer resistance to the passage of steam, and it is convenient to reckon the resistance offered by these as equal to that of a certain length of pipe of the diameter of the steam way through the valve, or elbow, or fitting. For globe valves, and the resistance offered by the entrance to a pipe, it is usual to take a resistance equal to that of a pipe of the same diameter, and of a length sixty times the diameter, and, for an elbow, forty times the diameter. The discharge of steam in pounds per minute through any pipe, with a given drop in pressure, has been calculated, and also the drop in pressure in pounds per square inch, corresponding to any given drop, have also been calculated, and they are given in the annexed tables.

On the other hand, one of the great evils to which steam is exposed in its passage through steam pipes is the loss of heat owing to radiation from the external surface of the pipe, and this, it will be evident, will depend directly upon the extent of the surface of the pipe, and will increase in direct ratio to the diameter. Hence, it is a disadvantage to employ too large a pipe, because the loss of heat leads to condensation of some part of the steam, and this leads to a double evil—loss of the steam itself as a useful agent for power, and presence of water in the steam system that must be got rid of, or that will lead to serious trouble.

## Water Hammer

By water hammer is meant the effect that is produced in steam cylinders, and in steam pipes, by the presence of water, the water being driven forward by a rush of steam. Thus, in a steam cylinder, if water is present, and steam is suddenly allowed to pass into the cylinder in a large quantity, the water, which is practically incompressible, acts exactly as a hammer driven with great violence against the end of the cylinder, and has often been known to drive off the cylinder cover. Similarly, when engines are standing, and steam is present in the steam pipes connecting them with the boiler, and steam be suddenly allowed to drive through the steam pipes, if water be present in them, it is driven up against the surfaces of the pipes and against any projecting surfaces, as where pipes make a bend, and so on, the result being that joints are seriously weakened and pipes are sometimes burst. The water being practically incompressible, is driven forward at the velocity of the steam, hence the enormous energy expended.

TABLE XXI.  
FLOW OF STEAM THROUGH PIPES.

Diameter of pipe in inches. Length of pipe equals 240 diameters.

Initial gauge pressure—pounds per square inch.	Diameter of pipe in inches.																	
	3	1	1½	2	2½	3	4	5	6	8	10	12	15	18				
1	1.16	2.07	5.7	10.27	15.45	25.38	46.85	77.3	115.9	211.4	341.1	502.4	804	1177				
10	1.44	2.57	7.1	12.73	19.15	31.45	58.05	95.8	143.6	232.0	422.7	622.5	996	1458				
20	1.70	3.02	8.3	14.94	22.49	36.94	68.20	112.6	168.7	307.8	496.5	731.3	1170	1713				
30	1.91	3.40	9.4	16.84	25.35	41.63	76.84	126.9	190.1	346.8	559.5	824.1	1318	1930				
40	2.10	3.74	10.3	18.51	27.87	45.77	84.49	139.5	209.0	381.3	615.3	906.0	1450	2122				
50	2.27	4.04	11.2	20.01	30.13	49.48	91.34	150.8	226.0	412.2	665.0	979.5	1567	2294				
60	2.43	4.32	11.9	21.38	32.19	52.87	97.60	161.1	241.5	440.5	710.6	1046.7	1675	2451				
70	2.57	4.58	12.6	22.65	34.10	56.00	103.37	170.7	255.8	466.5	752.7	1108.5	1774	2596				
80	2.71	4.82	13.3	23.82	35.87	58.91	108.74	179.5	269.0	490.7	791.7	1166.1	1866	2731				
90	2.83	5.04	13.9	24.92	37.52	61.62	113.74	187.8	281.4	513.3	828.1	1219.8	1951	2856				
100	2.95	5.25	14.5	25.96	39.07	64.18	118.47	195.6	293.1	534.6	862.6	1270.1	2032	2975				
120	3.16	5.63	15.5	27.85	41.93	68.87	127.12	209.9	314.5	573.7	925.6	1363.3	2181	3193				
150	3.45	6.14	17.0	30.37	45.72	75.09	138.61	228.8	343.0	625.5	1009.2	1486.5	2378	3481				

Weight of steam per minute in pounds, with 1 lb. loss of pressure.

TABLE XXII.  
FLOW OF STEAM THROUGH PIPE.

LENGTH OF PIPE ONE THOUSAND FEET.

Discharge in pounds per minute corresponding to drop in pressure on right for pipe diameters in inches in top line.

Diameter ...	12 ins.	10 ins.	8 ins.	6 ins.	4 ins.	3 ins.	2½ ins.	2 ins.	1½ ins.	1 in.
Discharge	2328	1443	799	371·0	123·0	55·9	28·8	18·1	6·81	2·52
„	2165	1341	742	344·0	114·6	51·9	27·6	16·8	6·52	2·34
„	1996	1237	685	318·0	106·9	47·9	26·4	15·5	6·24	2·16
„	1830	1134	628	292·0	97·0	43·9	25·2	14·2	5·95	1·98
„	1663	1031	571	265·0	88·2	39·9	24·0	12·9	5·67	1·80
„	1580	979	542	252·0	83·8	37·9	22·8	12·3	5·29	1·71
„	1497	928	514	239·0	79·4	35·9	21·6	11·6	5·00	1·62
„	1414	876	485	226·0	75·0	33·9	20·4	10·9	4·72	1·53
„	1331	825	457	212·0	70·6	31·9	19·2	10·3	4·43	1·44
„	1248	873	428	199·0	66·2	23·9	18·0	9·68	4·15	1·35
„	1164	722	400	186·0	61·7	27·9	16·8	9·03	3·86	1·26
„	1081	670	371	172·0	57·3	25·9	15·6	8·38	3·68	1·17
„	908	619	343	159·0	52·9	23·9	14·4	7·74	3·40	1·08
„	915	567	314	146·0	48·5	21·9	13·2	7·10	3·11	0·99
„	832	516	286	132·0	44·1	20·0	12·0	6·45	2·83	0·90
„	748	464	257	119·0	39·7	18·0	10·8	5·81	2·55	0·81
„	665	412	228	106·0	35·3	16·0	9·6	5·16	2·26	0·72
„	582	361	200	92·6	30·9	14·0	8·4	4·52	1·98	0·63

TABLE XXIII.  
FLOW OF STEAM THROUGH PIPE.

LENGTH OF PIPE ONE THOUSAND FEET.

Drop in pressure in pounds per square inch corresponding to discharge on left; densities and corresponding absolute pressures per square inch in first two lines.

Density ...	0·208	0·230	0·284	0·328	0·401	0·443	0·506	0·548
Pressure ...	90	100	125	150	180	200	230	250
Drop	18·10	16·4	13·3	11·1	9·39	8·50	7·44	6·87
„	15·60	14·1	11·4	9·60	8·09	7·33	6·41	5·92
„	13·3	12·0	9·74	8·18	6·90	6·24	5·47	5·05
„	11·1	10·0	8·18	6·88	5·76	5·21	4·56	4·21
„	9·25	8·36	6·78	5·69	4·80	4·34	3·80	3·51
„	8·33	7·53	6·10	5·13	4·32	3·91	3·42	3·16
„	7·48	6·76	5·48	4·60	3·88	3·51	3·07	2·84
„	6·67	6·03	4·88	4·10	3·46	3·13	2·74	2·53
„	5·91	5·35	4·33	3·64	3·07	2·78	2·43	2·24
„	5·19	4·69	3·80	3·19	2·69	2·44	2·13	1·97
„	4·52	4·09	3·31	2·78	2·34	2·12	1·86	1·72
„	3·90	3·53	2·86	2·40	2·02	1·83	1·60	1·48
„	3·32	3·00	2·43	2·04	1·72	1·56	1·36	1·26
„	2·79	2·52	2·04	1·72	1·45	1·31	1·15	1·06
„	2·31	2·09	1·69	1·42	1·20	1·08	0·949	0·877
„	1·87	1·69	1·37	1·15	0·97	0·878	0·769	0·710
„	1·47	1·33	1·08	0·905	0·762	0·690	0·604	0·558
„	1·13	1·02	0·828	0·695	0·586	0·531	0·456	0·429

## The Arrangement of Steam Pipes

The arrangement of the pipes of a steam system must be such as will provide for getting rid of the water that is formed by condensation and, as explained below, for the expansion and contraction of the pipes. The usual arrangement is, a steam pipe rises from the top of each boiler, and is connected to the common steam main, by a proper flanged steam-tight joint, a stop valve being fixed between the boiler and the steam main. It is of advantage to arrange that the stop valve between the boiler and the main shall close automatically, in case anything happens to the steam connection, to prevent the rush of steam into each particular boiler in case of accident. The engines are supplied by pipes from the steam main, and these should always be taken from the upper side of the main, and steam separators should be fixed between the branch steam pipes and each engine. Provision must be made for draining the steam system, and this may conveniently be done by extending the main steam pipe a little beyond the engines to be supplied, by a pipe specially for the purpose, ending in a steam trap, and a pipe from this steam trap may be carried back to the boiler below the water-line, and the steam separators from all the engines may drain into this pipe and any other traps that are in the system.

Pockets in the steam piping and places such as the top of valves where condensed water may settle must be avoided as much as possible, because, though the water may remain in the pocket quiescent under ordinary working conditions, when the engines beyond the pocket call for a sudden increase of steam, the action that has been described, of any gas passing over a body of water, will draw up the condensed water in the pocket and will carry it before the steam at the velocity of the steam, and possibly deliver it into the engine, with the attendant troubles. Lodgment on the top of valves leads to danger of a similar kind when the valves are opened.

The steam pipe should slightly incline in the direction in which the steam is to travel, so that any condensed water that is formed will drain naturally towards the steam trap at the end of the system, and will keep, when not disturbed, to the lower part of the pipe. When it is necessary to raise the pipe to supply a certain engine, a steam trap should be fixed at the lowest part of the portion which rises, so that any water that is formed may be drained away.

Steam pipes are jointed by the aid of flanges cast on their ends, the two flanges of adjacent pipes being butted together, and bolted closely with some substance between the two flanges that will prevent the egress of steam. Substances that are employed for this purpose are rubber rings, lead rings, rings formed of asbestos



and rubber, and rings formed of corrugated metal. It is important that the pipes shall be properly supported, so that their weight shall be taken off the joints. It will be understood that the weight of a large pipe constantly upon the bolts upon which the joints between the two lengths of pipes depends, will tend to pull the flanges away from each other in one part of the pipe, and to crush the material used for the joint at another part of the pipe, the result being a possible leakage of steam. Steam pipes are supported by brackets fixed to the walls or hangers from beams, or in any convenient way, the supports being merely rings made in two halves so that they can be clasped around the pipe, the ring being held by rods from above or by the brackets from the sides, or in any convenient way.

The ring main system of steam pipes was at one time introduced into some of the electricity generating stations, but has now been practically abandoned. The idea of the arrangement was similar to that of the ring system of electrical distribution employed by some of the earlier electricity supply companies in London, and which ensured two chances of supply to any particular group of consumers. A ring of steam pipes was taken round the boilers and the engines, which were fixed back to back, and it was supposed that in case of anything happening, there were two chances of getting steam to the engines. Practice has shown, however, that the two chances are of breakdown rather than of increased service, and, meanwhile, the more than double length of steam main gives more than double the loss by radiation.

There is another important matter in connection with steam pipes, and that is that they are exposed to the expansion and contraction that has been mentioned in connection with all apparatus that is exposed to heat. When the system is under steam, every part through which the steam passes assumes a temperature equal to, or nearly equal to, that of the steam, and expands with it; and when the system is at rest, with no steam passing through it, or even when steam remains in the system, but with engines not working, and therefore the steam is at rest, cooling takes place, the pipes following the lower temperature and contracting with it. In a long length of pipe, such as that connecting a range of boilers to a range of engines, as in an electricity generating station, and, again, long pipes connecting boilers to engines at a distance, the expansion and contraction will often be considerable, especially with steam at high pressures. The difficulty is met by fixing expansion bends, as they are called, in the range of steam pipes, the bend moving, altering its shape, taking up the increased length due to the expansion, and giving back the increased length it received, when contraction takes place. This is the more modern method of providing for expansion and contraction,

but arrangements on the lines of that shown in Fig. 126, known as jointing rings, are also employed. It will be seen that the ends of

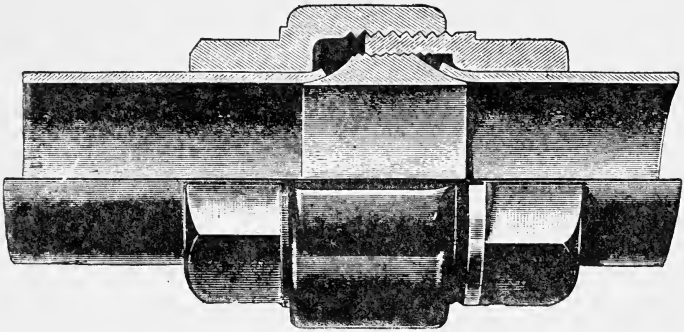

FIG. 126.—“Wedgring” Coupling for Steam Pipes, made by the British Steam Specialities Co.

the pipes are held by the couplings shown, the expansion and contraction being taken up by the middle portion of wedge section, whose shape makes provision against leakage of steam.

## Steam Traps

An apparatus, of which there are various forms, and which is very necessary in all steam systems, is the steam trap, to collect the water formed from condensed steam in, say, a long range of pipes or where bends, etc., occur. As explained, it is a very serious matter for water to pass into an engine cylinder, or to be driven violently against a dead end.

There are two main lines upon which steam traps are worked—by the expansion and contraction of a tube or rod opening and closing a valve, allowing the water to pass out of the pipe to be drained; and by the action of gravity, the weight of the water that is drained from the steam pipe closing the aperture through which it has passed. The trap is always, or should be, connected to the lowest part of the steam pipes to be drained, and it should contain, or discharge into, a vessel from which the condensed water gathered by it can be delivered to the hot well, or wherever the feed water for the boiler is taken from. The amount of condensed water collected by steam traps on a large service of steam pipes is considerable throughout the day, and should, in many cases, effect some economy in steam working if collected.

In all cases the action of the steam trap is, or should be, automatic. It is connected to the pipe by drilling a hole, or the

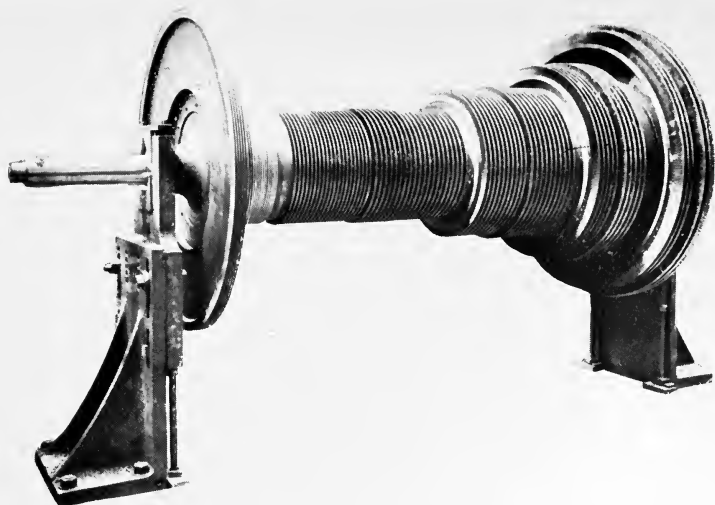

PLATE 18A.—Rotor of Brush and Parsons' Steam Turbine.

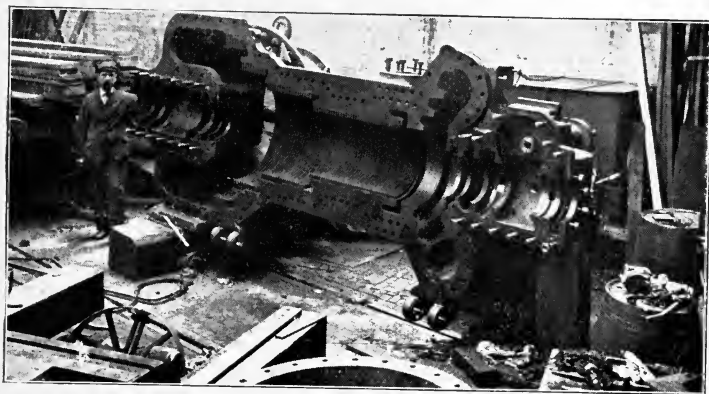

PLATE 18B.—Half of Stator of Brush & Parsons' Turbine.

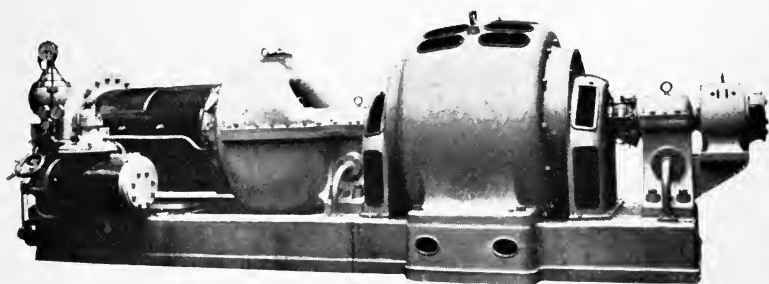

PLATE 18C.—Brush & Parsons' Turbine directly connected to Alternator and its Excitor.

[To face p. 280.]



equivalent, and screwing the connecting pipe of the steam trap into it, and the usual arrangement is, the steam in the steam pipe forces out the water that has been condensed in front of it through the connecting pipe, into the trap and discharges it, and then closes the valve through which the water was forced, until a further quantity is collected. Steam traps are made to lift the condensed water which they drain off, to a certain height, the box in which the trap is contained being made to withstand higher steam pressures than where it is merely to act as a water holder, and the pressure of the steam inside being made to force the water out.

The following are a few examples of different forms of steam traps.

**Brooke's Steam Trap.**—In this apparatus, which is shown in Figs. 127 and 128, the expansion and contraction of a metal tube, which

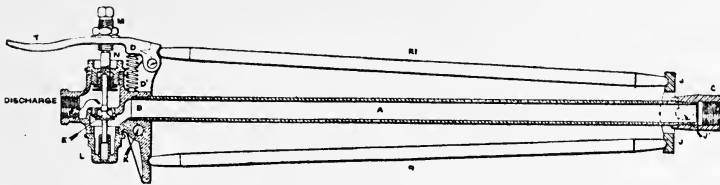

FIG. 127.—Sectional view of the Brooke Steam Trap. **A** is the Steam Pipe to be drained; **E** is the Valve, which is opened and closed by the lever **D**, actuated by the expansion and contraction of **A**.

is open to the steam from the pipe the trap is intended to drain, actuates a valve, which automatically discharges the water that has collected. In Fig. 127, in which the whole of the apparatus is shown in section, **A** is the tube connected to the steam pipe, into which the steam enters, and it is held in a pair of rod guides, **R** and **R1**, the upper one of which actuates the lever **D**, which, in its turn, opens or closes the valve **E** shown below.

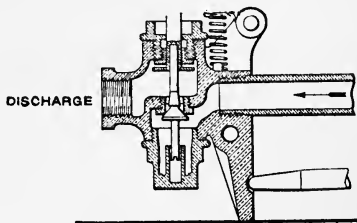

FIG. 128.—Section of Discharge End of Brooke's Steam Trap. Steam enters by the Pipe shown, in the direction of the Arrow, and when Water also enters, the cooling effect contracting the Steam Pipe actuates the Levers operating the Valve shown, opening it, the reverse operation closing it.

In Fig. 128, in which the valve and the parts connected with it are shown larger, and in section, the valve with its vertical rod will be noticed, as also the discharge pipe on the left and the connection between the steam pipe through which the water enters, and the space leading to the discharge, which is opened when the valve rises. When water enters the tube **A**,

driven into it by the steam behind it in the steam pipe, the presence of the water lowers the temperature of the tube, causing it to contract, and to compress the guide rods R, R1. The upper guide rod, as explained, then works the lever D, depressing the valve E, opening a passage between the tube A and the discharge opening, the water present in the tube then being driven out. Immediately the water has been driven out, a certain portion of the steam which drove it out follows. The temperature of the tube A then being raised, it elongates, carrying with it the guide rods R and R1, the guide R then operating the valve rod of the valve E in the opposite direction, closing the valve and shutting the discharge pipe.

In the arrangement recommended by the makers of the Brooke steam trap for draining boiler steam pipes, the trap is connected to

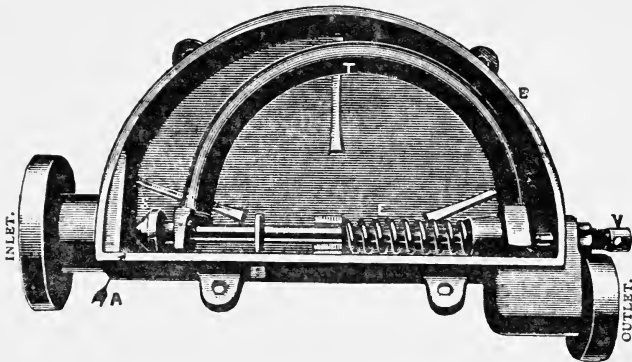

FIG. 129.—Inside view of "Sirius" Steam Trap. The semicircular Tube expands and contracts and moves the Rod to and fro, closing or opening the Valve on the left.

the boiler pipe immediately outside of the stop valve, and it has a cock inserted in the pipe leading to the trap, by which the trap can be shut off by hand. The trap is made for pressures up to 200 lbs. per square inch, and a special form up to 300 lbs.

**Sirius Steam Trap.**—This apparatus, which is also made by Messrs. Holden & Brooke, is shown in Fig. 129. As will be seen, the principle of the apparatus is very much the same as that of the Brooke trap, but the expanding tube is in the form of a semi-circle. Also, in place of the working parts of the trap being in the open, as in the Brooke trap, they are all enclosed within the semi-cylindrical case shown. The case with the inlet and outlet pipes forms a complete path for the steam when the trap is open. When at rest, that is to say when the trap is cold, when no steam is passing, the trap is open, and therefore when steam is turned on, it passes

through the trap case, full bore. As the trap warms up, the semi-circular tube expands and closes the entry valve on the left. As will be seen, the expansion and contraction of the tube moves the rod, which forms the diameter of the semi-circle, to and fro, compressing and elongating the spring upon the rod. The semi-circular tube in this case does not receive steam on the inside. It responds to the heat of the steam in the vessel in which it is enclosed. When water collects in the trap, the cooling effect causes the semi-circular tube to contract and to pull back the sliding rod and opening the valve, allowing the water to be blown out by the steam, after which the trap is again warmed up and the semi-circular tube expands and closes it.

**The Lancaster Steam Trap.**—The Lancaster steam trap is a good example of the other form of trap mentioned—that in which

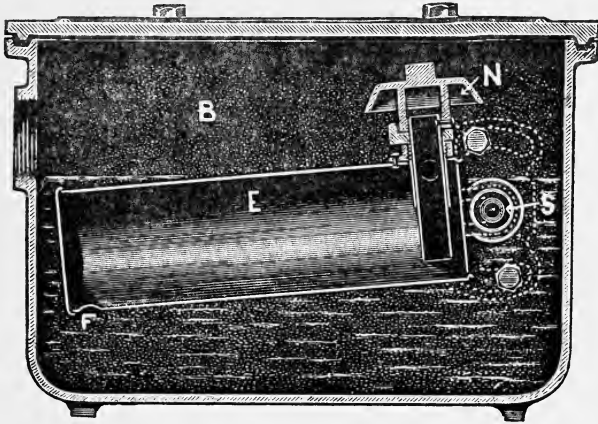

FIG. 130.—Longitudinal Section of Lancaster Steam Trap. **B** is the Box; **E** the Float; **S** the Axle upon which the Float turns.

a float is employed to open and close the valve discharging the water. Sections of the valve are shown in Figs. 130 and 131. The trap consists of the box shown in Fig. 130, in which the float **E** moves up and down, pivotted upon an axle, its rising and falling being controlled by gravity, as it becomes full of water or discharges it. When at rest, the float is at the bottom of the box. Connection is made to the trap through the pipe which forms the hollow steel spindle marked **S** in Figs. 130 and 131, upon which the float **E** moves. When the trap is open to a steam pipe, any water that may be present is driven by the steam through the hollow spindle **S** into the float **E**, gradually causing the latter to fall. The float has a hole at the bottom of the end removed from the

spindle, and the water which is delivered into the float passes through the hole F into the body of the box forming the trap. The float then

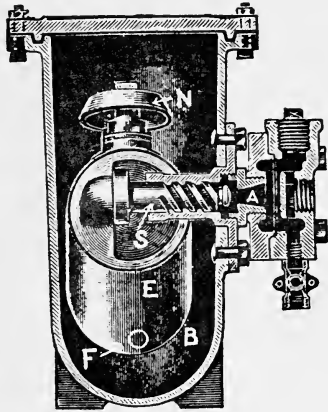

FIG. 131.—Transverse Vertical Section of the Lancaster Steam Trap shown in Fig. 130. The letters refer to the same parts.

becoming buoyant, rises and closes the admission valve. The steam drives the water out through the valve marked N. As the steam left in the float condenses, water from the box flows into it, when it again falls, opens the valve, the steam that enters driving the water out, and so on. It is claimed that as long as the trap is connected to any source of steam supply, it will continue to work to and fro in the manner described, discharging the water that has been brought over as long as any is present. It is also claimed that the valve, having a twisting motion, automatically grinds itself steam-tight. It is claimed also that the adjustable air valve N at the top of the float over-

comes the trouble that sometimes arises from the re-evaporation of the water that is brought over with the steam.

**The Water-Seal Steam Trap.**—The water-seal steam trap is claimed to be a steam separator and a steam trap as well. The apparatus has the usual steam inlet and outlet, and is arranged to be connected in the steam service in place of being merely tapped on to it. The steam enters on one side of a short casting and leaves by the other; but in passing through a spherical portion of the casting it is claimed that any water present is separated from the steam, which issues dry on the outlet side, the water being carried down into a sphere at the bottom. The head may also be simply connected to a steam service, instead of being inserted *in* the steam service. The inlet and outlet of the head are of the same diameter as the pipe the apparatus is to drain, but the spherical portion is usually double the diameter. On the steam entering the head, it is claimed that the water on the lower portion of the entry pipe falls directly into the globe below, to which the head is connected. The comparatively dry steam is made to follow a somewhat circuitous course, on the usual lines of the steam separator, in its passage from the inlet to the outlet ports, and during this passage it is claimed that the remainder of the water is separated.

What is termed a sensitive tube, which is of a diameter not less than that of the steam pipe that is being drained, and which varies



in length from 8 to 16 inches, is fixed to the lower side of the head, and this tube performs the usual office of opening and closing the water discharge valve by its expansion and contraction. A spherical vessel is attached to the lower portion of the sensitive tube, and inside of the sensitive tube is a smaller discharge tube leading to the discharge valve, and extending nearly to the bottom of the lower sphere. The sphere at the bottom is called the water-seal chamber, and its office is to cover with water the open end of the internal discharge tube, so that no steam can pass that way. There are two rods rising from the lower globe leading to levers, which operate the discharge valve. As the sensitive main tube rises and falls, the side rods open and close the discharge valve and allow the water that has collected in the lower spherical chamber to be blown out by the steam, the valve being closed when the water has been blown out, and reopened later by the admission of water, and so on.

### **Steam Traps Operating by the Expansion of a Volatile Spirit**

There is a line of steam traps made by the Steam Fittings Co., in which the usual arrangement of an expanding and contracting metal rod or tube, is replaced by expansion and contraction of a volatile spirit, moving a diaphragm, to which a tube is attached, whose motion opens and closes the trap. In the form known as the Midget, there is a hollow chamber at the top of the apparatus, in which a flexible diaphragm is stretched, the volatile liquid mentioned being enclosed in the space above the flexible diaphragm, and the tube which opens and closes the valve being attached to the lower part. Steam enters at an inlet on the left, and when the central tube is raised, it passes through the apparatus, and out by an outlet on the right, driving any water that may be present before it. The rising and falling of the flexible diaphragm, is controlled by the heat of the steam when present, and the cooling of the water when any is brought over. When the spirit is condensed, in the chamber above the diaphragm, the central tube rises, and allows the steam and water to pass through. When steam passes up into the central tube, having driven all the water present through the apparatus, the heating effect of the steam causes the volatile spirit to evaporate, the pressure created forcing the central tube down, and closing the trap, this operation going on continuously, as long as the connection is made to the steam pipe to be drained, and there is water to be carried away. It is recommended that the trap should be fixed as close as possible to the apparatus to be drained.

### The Reservoir Steam Trap

The reservoir steam trap is a modification of the Midget, intended for larger work. There is the same chamber, with an inner chamber formed by flexible diaphragms, controlling the valve of the apparatus, but it is below the entry pipe in place of above, as in the Midget. The rising and falling of the valve is controlled by the evaporation and condensation of the volatile liquid in the flexible chamber, as before, but the water that passes in to the apparatus is allowed to fill the chamber, and to overflow to the outlet through a tube in the centre, connecting to the outlet port. The reservoir is a copper dome, and it is the cooling of the copper dome which cools the flexible diaphragm chamber, by conduction, that leads to the closing of the pipe.

### The Euston Steam Trap

This is another apparatus made by the Steam Fittings Co., in which the arrangement of the valve is very similar to that of the diaphragm controlled valves described above, but the expanding tube itself forms the portion of the valve which opens and closes, and is itself operated directly by the heat of the steam, and the cooling effect of the water. The tube forming the valve, and which responds to the change of temperature, has an inner tube, whose position can be regulated by a screw at the top of the apparatus. The water that is brought over by the steam, in the process of draining, is forced through the annular space between the two tubes, and in its passage cools the outer tube, causing it to contract, thereby rising and opening the valve for the passage of the water straight through.

### The Anderson Trap

This is an apparatus made in America, in which the opening and closing of the valve is controlled by the rising and falling of a ball, very much on the lines of the ordinary ball cock employed for household water supply, the expansion and contraction of the ball opening and closing the valve, in place of the rising and falling of the water. One feature of the trap is, the sediment chamber at the bottom, into which any grit, etc., that comes over falls, it being claimed that this prevents the valve itself being choked by the grit. The valve of the trap is sealed with 3 or 4 inches of water, and it is claimed that this prevents the loss of steam.

## Relief Valves

Relief valves are fitted to various portions of the steam system, such as the cylinder, the main steam pipe, etc., and they are made in various forms, a favourite one being a spring-loaded valve, which opens when the tension of the spring is overcome by the pressure of the steam in the space the valve is intended to protect.

Valves are also arranged to cut off boilers, should the steam main burst, or should a tube in one of the boilers burst. The arrangement consists of a differential valve, kept in balance so long as the system is working properly, and coming into operation, and closing the valve, should the steam main or one of the tubes of any particular boiler burst.

## CHAPTER V

### THE STEAM TURBINE

THE steam turbine differs from the reciprocating engine, in the very important point that the direction of motion of its moving parts is never reversed. In the reciprocating engine, as has been explained, the piston, which receives energy from the steam and converts it into mechanical energy, moves to and fro, and is consequently subject to all the disadvantages that have been mentioned in connection with to-and-fro motion. The steam, for instance, has to be pushed out of the cylinder, after it has done its work, and different arrangements have to be made to ensure that the full work of the cylinder of steam is obtained, and so on. In the turbine, in all forms, there is an axle, upon which are mounted apparatus designed to give rotary motion to the shaft directly, and without the intervention of any converting apparatus, such as a crank shaft, and the motion so obtained is continuous, so long as the steam is passing through the apparatus, and is always in the same direction. All forms of turbine have a closed vessel, in which the moving axle is carried, on bearings, just as a crank shaft is carried, the enclosed chamber being sufficiently large to accommodate the apparatus that is to receive the energy from the steam, and to convert it into rotary motion.

#### Classes of Steam Turbines

There are two classes of steam turbines, known respectively as the pressure turbine and the velocity turbine, the latter being sometimes called the impulse turbine. Their names are taken from the fact that the one receives the steam at the full pressure, just as a reciprocating engine does, and allows it to expand down to the lowest pressure obtainable by the aid of a good condensing apparatus; while the other receives the steam at the lowest pressure that can be produced, under the conditions, whether that be atmospheric or condenser pressure, and the energy of the steam is converted into

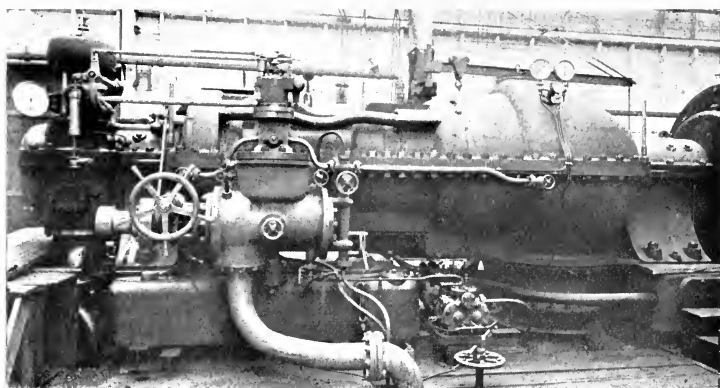

PLATE 19A.—Parsons Turbine, made by Messrs. Richardson & Westgarth, showing Steam and Oil connections, Governor, etc.

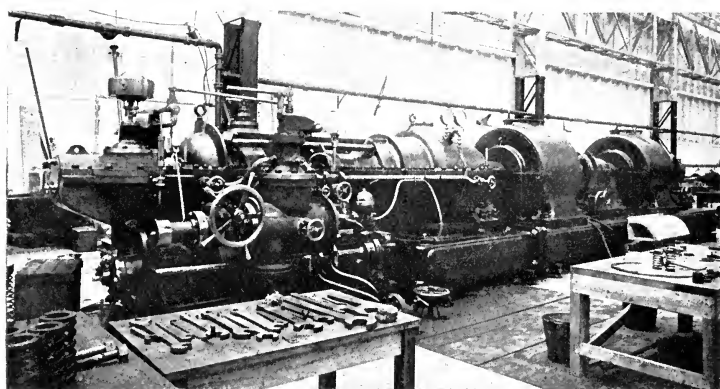

PLATE 19B.—Richardson's, Westgarth's, and Parsons' Steam Turbine directly connected to two Electricity Generators, as viewed from the Steam end.

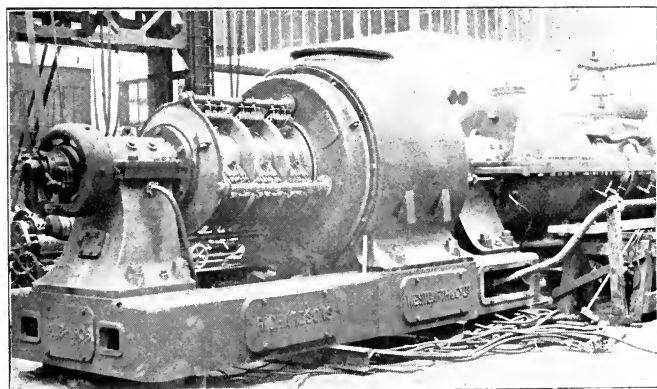

PLATE 19C.—Richardson's, Westgarth's, and Parsons' Steam Turbine directly connected to a Tube, whose Alternator and its Excitor are seen from the Generator end.  
[To face p. 288.]



mechanical energy, by the passage of the steam through the apparatus at a high velocity. The two forms are also sometimes called, reaction (pressure), and action (velocity) turbines.

There is an intermediate group of turbines, in which the steam is expanded down to the exhaust pressure by stages, each stage forming a velocity turbine in itself, but the different stages being arranged with regard to each other, very much as the different cylinders of a compound or triple-expansion reciprocating engine are, and the pressure of the steam being gradually lowered at each stage.

It will be understood from what has been stated in previous portions of this book, that the steam possesses energy in virtue of the heat which has been imparted to it in the boiler, part of it being the latent heat causing it to change its physical condition from water to steam, and the other part being energy imparted to it after its conversion into steam, by the continuous delivery of heat to it, the continuous generation of steam in the boiler, and by the consequent increased pressure upon the steam already there. Energy may be either in the potential or kinetic form. By potential energy is meant, the ability to perform work, if certain things are done to the object possessing the potential energy. Thus, a rock poised at the top of a mountain peak, possesses potential energy in proportion to its weight and to its height above the plain below, or the sea level, if it is able to reach it; and it will accomplish the work represented by its potential energy if its supports are removed, say by its being loosed from its bed, forced over the precipice, and so on. Similarly, a column of water in a pipe, extending from a reservoir at a height above a river in a valley below, possesses potential energy, which is measured by the weight of the water in the pipe, and the vertical height through which it would fall in passing to the river, or to the sea, when it finally reached it.

Immediately potential energy is released, it becomes converted into kinetic energy. Thus, in the case of the column of water, when it is made to move a turbine near the bottom of the valley, the kinetic energy possessed by the moving water is delivered to the turbine, and is there converted into mechanical energy. Similarly with steam, the steam present in the boiler possesses potential energy, in proportion to its pressure, and to its quantity. Its potential energy is converted into kinetic energy immediately it commences to move, whether it is driving the piston of a reciprocating engine, or the moving member of a turbine. It will be remembered also that, as was explained in Chapter I., the volume of the steam, and of any gas, varies inversely with the pressure to which it is subject, in accordance with the formula—

$$pv = \text{a constant}$$

It will be evident, therefore, that given a certain body of steam, at a certain pressure, if it is allowed to expand to lower pressures without losing or receiving heat from any source, adiabatically as it is called, the larger volume of the steam will be possessed of the same amount of energy as the smaller volume, and will deliver its energy to any apparatus that can receive it, provided that arrangements can be made to utilize the energy possessed by the steam at the lower pressure without loss. And this is what is done in the velocity turbine. The steam is expanded down to the lowest pressures obtainable by condensation, in the latest apparatus, as will be explained, about 1 lb. pressure absolute, and the energy of the enormously increased volume of the steam is utilized by driving it through the turbine at a very high velocity. In the table given below, taken from a paper read by Mr. Konrad Andersson before the Institution of Engineers and Shipbuilders in Scotland, the different velocities, kinetic energies, and horse-powers are given for steam at different initial pressures, when opposed to different counter pressures.

TABLE XXIV.

THE VELOCITY OF OUTFLOW AND THE WORKING CAPACITY OF DRY SATURATED STEAM.

Initial steam pressure. Pounds per square inch.	Counter-pressure 1 atm.			Counter-pressure 2·4 lbs. per square inch absolute corresponding to 25 inch vacuum.			Counter-pressure 0·93 lbs. per square inch absolute corresponding to 28 inch vacuum.		
	Velocity of outflow of steam. Feet per second.	Kinetic energy. Ft.-pounds per second.	H.P. of 550 ft.-pounds per second.	Velocity of outflow of steam. Feet per second.	Kinetic energy. Ft.-pounds per second.	H.P. of 550 ft.-pounds per second.	Velocity of outflow of steam. Feet per second.	Kinetic energy. Ft.-pounds per second.	H.P. of 550 ft.-pounds per second.
		Per pound of steam per hour.			Per pound of steam per hour.			Per pound of steam per hour.	
60	2421	25·29	0·046	3320	47·57	0·087	3680	58·44	0·106
80	2595	29·06	0·053	3423	50·56	0·092	3793	62·08	0·113
100	2717	31·86	0·058	3520	53·47	0·097	3871	64·66	0·118
120	2822	34·37	0·062	3596	55·80	0·101	3940	66·99	0·122
140	2913	36·62	0·066	3661	57·84	0·105	3999	69·01	0·125
160	2992	38·63	0·070	3718	59·65	0·108	4045	70·61	0·128
180	3058	40·35	0·073	3764	61·14	0·111	4091	72·22	0·131
200	3115	41·87	0·076	3810	62·64	0·114	4127	73·50	0·134
220	3166	43·26	0·079	3852	64·08	0·116	4159	74·64	0·136
280	3294	46·83	0·085	3962	67·74	0·123	4229	77·18	0·140

It will be understood that in the steam turbine, as in the reciprocating engine, the steam, after passing through the turbine, is either exhausted to the atmosphere, or into a condenser, and that it has to force its way out against the pressure of the atmosphere, or that of the condenser, and that the velocity with which the steam passes



through the turbine, is reduced by the counter pressure. Thus, it will be seen that while with 60 lbs. initial pressure, the velocity of outflow of the steam is 2421 feet per second when exhausting to the atmosphere, it becomes 3320 feet per second with a vacuum of 25 inches, and 3680 feet per second with a vacuum of 28 inches, the velocity of steam at 200 lbs. pressure being increased from 3115 feet per second when exhausting to the atmosphere, to 3810 feet per second with 25 inches of vacuum, and 4127 per second with 28 inches of vacuum. A very striking point will be noted here, viz. that the velocity of the steam and its kinetic energy and horse-power is greater with 60 lbs. initial pressure and a 25-inch vacuum, than with 200 lbs. initial pressure and exhausting to the atmosphere. Also, that with 60 lbs. initial pressure and 28-inch vacuum, the velocity of the steam and the horse-power is greater than with 140 lbs. initial pressure and the 25 inches of vacuum. This was explained fully in the first chapter, it being due to the larger quantity of heat that is set free at the lower pressures.

### Difference between Pressure and Impulse Turbines

It will probably be difficult for the student to grasp the difference between pressure and impulse turbines, or, as the author prefers to call them, pressure and velocity turbines, because, as will be seen from the descriptions given further on in the book, of the different forms of turbines, the construction of the two forms is almost identically alike. The fundamental difference may be taken to be as follows:—In the velocity or impulse turbine, there are one or more closed chambers, into which the steam that is to drive the turbine wheel is expanded, and it drives the wheel purely by its velocity—by the speed at which the steam passes through the wheel. In the pressure turbine there are no closed chambers, the expansion of the steam is continuous from its entry to its exit. It expands at each of the guide rings, as they are termed, the rings of blades separating the rings of blades on the moving member of the turbine, and it also expands as it passes through the blades on the moving member itself. Further, the steam can pass, not only through the guide blades, but round them, and not only through the blades on the moving member, but also round them, in the small space between their ends and the enclosing chamber.

As explained above, the later forms of impulse turbines are really combinations of pressure and velocity apparatus. That is to say, the steam is expanded from the initial boiler pressure to a certain low pressure in the first stage, then to a further lower pressure in the second stage, and so on.

## Compounding in Pressure Turbines

The different sizes of rings of blades in the pressure turbine, correspond to the different sizes of cylinders with reciprocating engines, the steam being gradually expanded as it passes through the apparatus from the entry port to the exhaust port, but with the great advantage over the reciprocating engine, that the expansion is continuous right through the apparatus. Thus the steam entering at the smaller end of the enclosing cylinder, passes through the first ring of blades, then through a ring attached to the casing, then through another ring on the axle, through a second ring attached to the casing, and so on. In passing through each ring of blades, whether attached to the axle or to the casing, the steam parts with a certain portion of its energy, and with a certain portion of its heat, its pressure becoming lower in accordance with the lowered temperature, as explained in Chapter I. The energy it parts with is delivered to the blades, and a certain portion of it acts radially, to give motion to the axle. It will be remembered that every force can be resolved into two forces at right angles to each other, and in this case the force acting upon each inclined blade, is resolved into two forces, one acting longitudinally, and tending to force the whole of the rotor against its end bearings, and the other tending to cause the rotor to revolve. As the steam passes through successive rings of blades, its pressure and temperature being lowered, the rings of blades, it will be seen, are increased in diameter, so that the turning moment given to the axle is maintained constant throughout the length of the turbine; this, it will be understood, being a very important point in connection with the apparatus.

## Forms of Pressure Turbine

**The Parsons Turbine.**—The earliest form of pressure turbine is the well-known Parsons, the invention of Hon. Charles Parsons. Sections of this turbine are shown in Figs. 132, 134 and 135, and also of the modifications of it made by Messrs. Willans and Robinson. The apparatus consists, as will be seen, of a long, cylindrical chamber, enclosing the axle mentioned on a previous page, the axle carrying a number of blades, slightly inclined to the radius. The blades are held within enclosing rings, which in Messrs. Willans' apparatus are of the form shown in Fig. 133, the inner end of the blade being dovetailed into a recess provided for it in the axle, and the outer end held by the enclosing ring. The rotor and stator of a Brush-Parsons turbine are shown in Plates 18A and 18B, and complete turbines by

the Brush Co. and Messrs Richardson's Westgarth, in Plates 18c, and 19A, 19B, and 19C. As will be seen from the figures, a number of blades are assembled together to form a complete ring, surrounding the axle, but the blades being slightly inclined to the radius of the

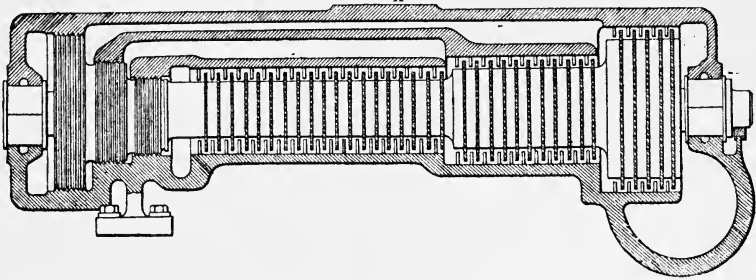

FIG. 132.—Section of Parsons Turbine, showing the Equalizing Pressure Rings at the Steam End.

apparatus, there is a space between adjacent blades. Rings of blades are placed on the axle, between similar rings fixed on the inside of the case, which in the Willans form are built up in exactly the same manner, one end of each blade being dovetailed into the case

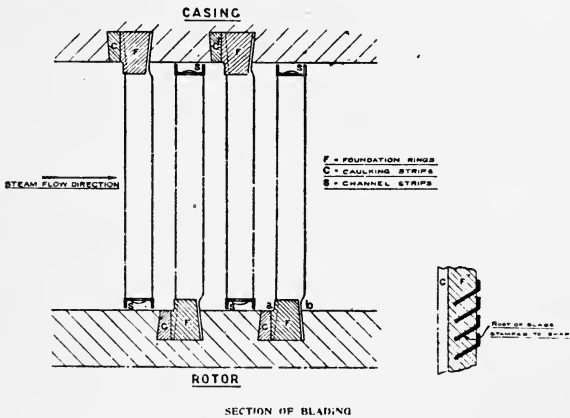

FIG. 133.—Willans' arrangement of Rotor and Stator Blades, with their Containing Rings, and the Joints to Shaft and Casing.

in a slot provided for it, and the other held by the enclosing ring. In all pressure turbines the rings of blades extend from the axle very nearly to the inside of the outer case, and the rings of blades fixed to the cylinder extend almost to the axle. As will be seen from

the Plates 18A and 18B, there are successive rings of blades increasing in size, and the diameter of the enclosing cylinder also increases in size from one end to the other. It will be noticed in Plate 18A, which represents the rotor, or moving member, of a Brush-Parsons turbine, that the rings of blades extend only a small distance radially outwards from the axle at the left-hand end, and that their size increases from left to right. The rings of blades fixed to the inside of the cylinders follow the same increase. The sizes of the blades, the length of the turbine, the number of the rings of blades, and so on, depend upon the horse-power that is to be developed by the turbine, the pressure of steam that it is to work with, and the quantity of steam that has to pass through it. It will be understood that with higher pressures of steam, the numbers of sections of rings of blades will be more than with lower pressures, and that where the turbine has to accommodate a large quantity of steam, it must be made larger in diameter than where it has only to accommodate a smaller quantity. Thus, with a comparatively low pressure of steam, the turbine would be shorter longitudinally, and larger in diameter than with higher pressure steam, for a given horse-power. On the other hand, it should be noted that the work done by any steam turbine is so largely at the low-pressure end of the steam scale, where high vacua can be obtained, that there is not a very great difference between the sizes of turbines for high and low pressure working.

There is another exceedingly important point in connection with the pressure turbine, and that is, the matter of the end thrust just mentioned. It was mentioned above, that the force applied to the inclined blades was resolved into two forces, at right angles to each other, one of them acting in the direction in which the steam is moving, and tending to force the shaft longitudinally against its end bearings. In some of the early machines, it was found that this was a somewhat serious matter, and Mr. Parsons overcame the difficulty by providing a dummy axle, forming an extension of the axle proper, beyond what would be the end bearing, the dummy axle having three discs, which were exposed to the pressure of steam at different portions of the rotating apparatus. In an earlier form of Parsons turbine also, the difficulty was overcome by making the turbine in duplicate, having two turbines in one casing, and on one axle, and admitting the steam to the centre between the two. This is only used for small sizes, because the efficiency of the steam turbine increases very rapidly with the size, and consequently when the work was divided between two small turbines, in place of one large one, the consumption of steam was considerably increased. In all later forms of Parsons turbine, as shown in Figs. 132 and 134, rings are fixed on the rotor axle behind the steam inlet, which are exposed to

different pressures of steam, and so balance the pressure due to the action that has been described. In Fig. 134, which is a section of a Willans-Parsons turbine; the enclosing case is shown shaded, and the different steam spaces, etc., are marked by different letters. Thus, A', A'', are the spaces in which the blades of the rotor revolve, and in which the stationary rings of blades are also fixed, the spaces being larger as the steam inlet is receded from. J is the entry port for the steam, C is a disc on the axle immediately behind the entry port, and exposed to the full steam pressure which enters there, and D is another disc fixed on the axle, still further behind the entry port, and exposed to steam acting upon the intermediate blades in the space A', connection between these spaces and the disc D being made by the pipe E. The pipe H which is seen below, and which communicates with the back of the disc, or balance

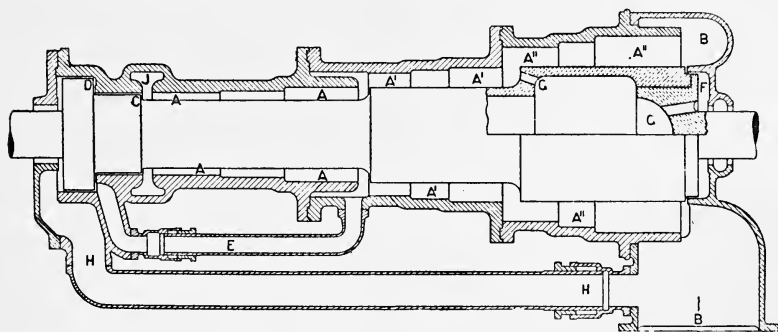

FIG. 134.—Section of Willans-Parsons Steam Turbine. AA, A'A', A''A'' are the several Steam Spaces; J is the Steam-entry port; C and D are the Balance Discs receiving pressure from the Steam Spaces by the passages E and H, H being connected to the Exhaust.

piston D, is in connection with the exhaust B, and tends to keep the apparatus in equilibrium.

In addition to the steam connections mentioned for balancing the end thrust of the rotor, connections are arranged to admit steam of full pressure to the intermediate sections of the turbine on special occasions, to enable it to pull with a temporary overload. This is the equivalent, in turbine work, of the practice that is sometimes employed, of admitting high-pressure steam into intermediate or low-pressure cylinders with reciprocating engines, to give high starting torque.

**The Bearings of the Parsons Turbine.**—The bearings of turbines are necessarily of very great importance, since the rotors and their axles revolve at very high speeds. In the Parsons turbine the

bearing is built up of four concentric cylinders having spaces between them, which are filled with oil under pressure. The inner cylinder forms the bearing proper and consists of the usual gun-metal sleeve, prevented from turning by a loose-fitting dowel, and the object of the three other sleeves is to enable the shaft to run about its axis of gravity instead of its geometric axis, the journal itself running slightly eccentric. It is claimed that this form of bearing fulfils the same office as the flexible shaft employed in the De Laval turbine described further on. The four cylinders forming the bearing are held in an outer cast-iron sleeve, and in all forms of turbine the bearings are very long. In the Parsons turbine there is an oil reservoir under the bearing at the steam end, as shown in Fig. 135, into which the oil from the bearings drains after it has done its work,

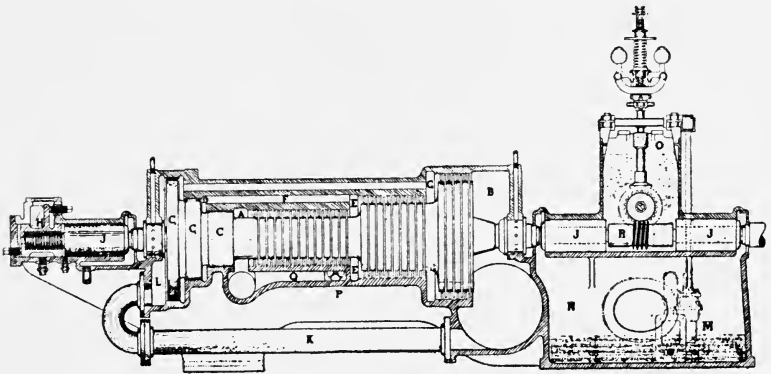

FIG. 135.—Section of Parsons Turbine, with Bearings, Lubricating Arrangement, and Governor.

and from which it is pumped to a chamber above the bearings at that end, from which it runs to the bearings by gravity, the necessary head being formed in the chamber. The oil pump is worked by worm-wheel gearing, taking motion from the main shaft.

**The Governor of Parsons Turbines.**—In Parsons turbines the steam is admitted to the containing cylinder in gusts, the quantity of steam admitted to the turbine at each gust being regulated by the time the admission valve is open, and this being controlled by a relay valve worked by the governor. The arrangement of the governor is shown in Figs. 135 and 136. It receives motion from worm gearing on an extension of the main shaft, and has the usual revolving balls, as shown, with the spiral spring opposing their outward motion. The vertical rod giving motion to the governor also acts as a fulcrum, at a point below the governor, for the system of



PLATE 20A.—De Laval Turbine, with Gearing and Pulleys arranged for two Drives from the same Machine. Made by Greenwood & Batley.

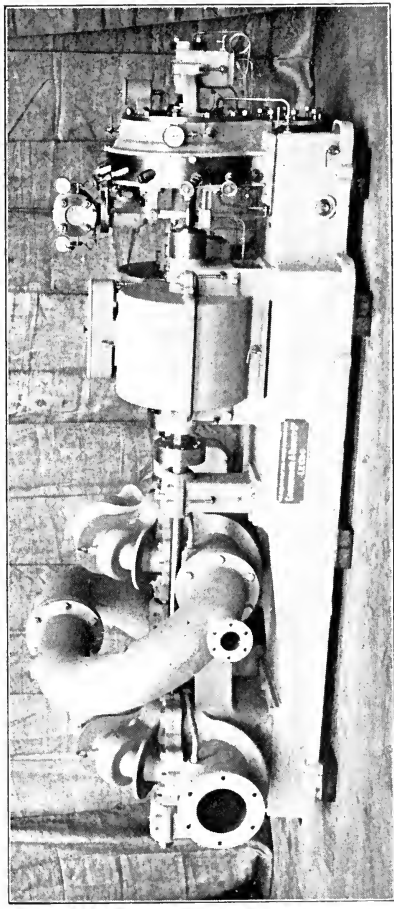

PLATE 20B.—De Laval Turbine, with Gearing directly connected to a 150 Horse-power De Laval Turbine Pump, the Pumps being in series. [To face p. 296.





levers shown in Fig. 136. In the figure the upper portion of the main steam admission valve is shown, and also the relay valve controlling it, and it will be seen that the relay valve is worked by the system of levers mentioned, the levers receiving motion from an eccentric on the main shaft, the levers, the eccentric and the governor together controlling the relay, and the relay controlling the time the main valve is open, at each gust. The governor controls the motion by varying the plane of oscillation of the relay valve, this causing the main admission valve to remain open a longer or shorter time. It will be seen that this arrangement is the equivalent of the admission

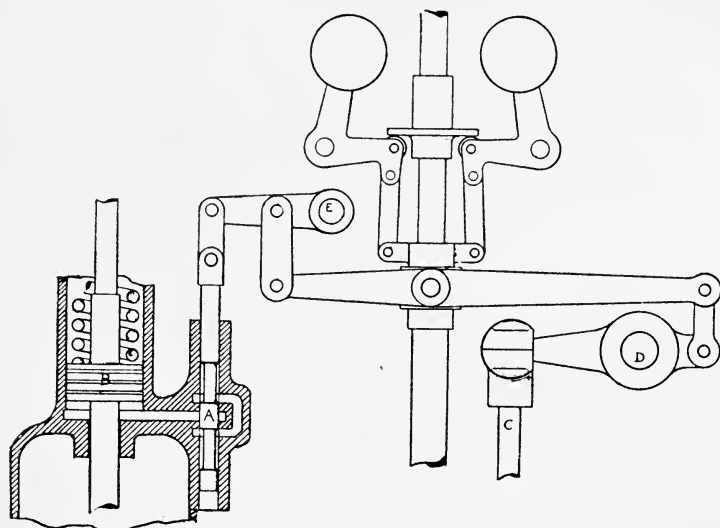

FIG. 136.—Sectional Drawing of Parsons Steam-turbine Governor. **A** is the Relay Valve.

valve of a reciprocating engine with variable cut-off, but with the advantage that the passage of steam into the cylinder is always in the same direction, and is practically continuous.

For governing the turbines employed for driving electricity generators, Mr. Parsons employs an electrical apparatus, consisting of a solenoid with shunt and main windings, the relay operating the main admission valve being controlled by the pull of the solenoid, and this, again, being controlled by the work the generator is being called upon to perform. When the load on the generator increases, the main winding of the electric governor receives an increased current, the shunt winding having its current slightly decreased, and the admission valve in consequence being open longer at each gust,

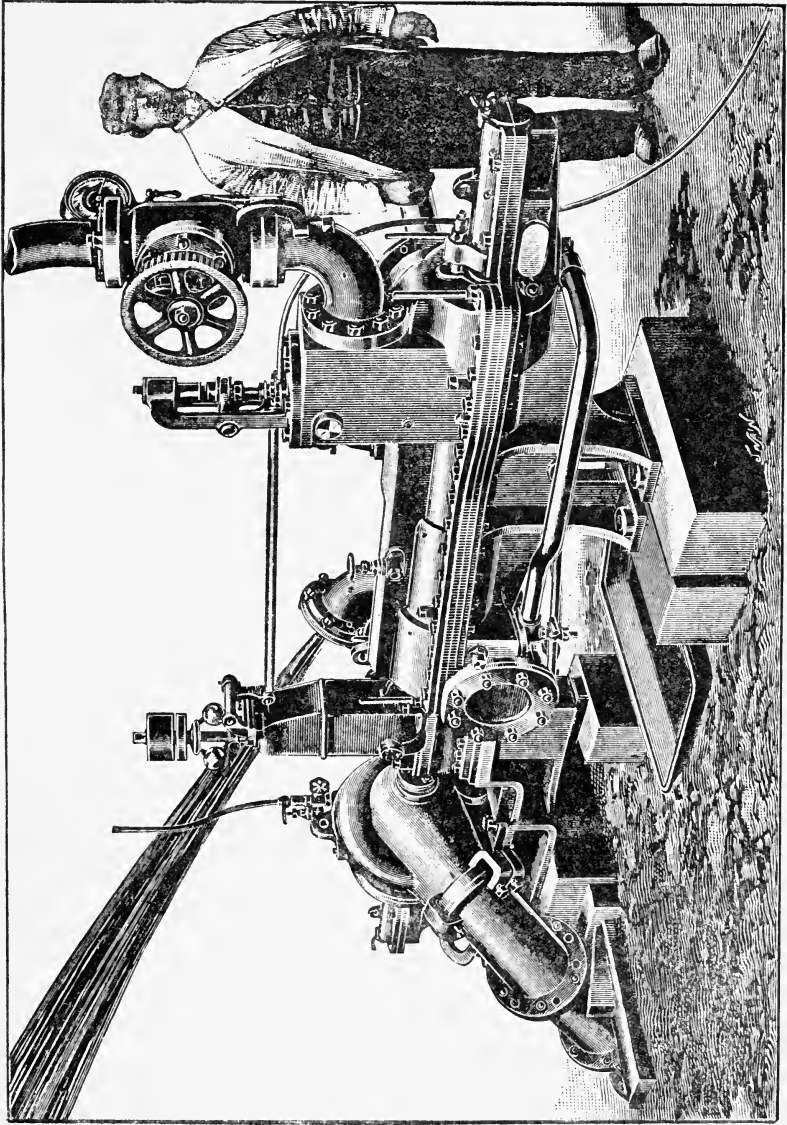
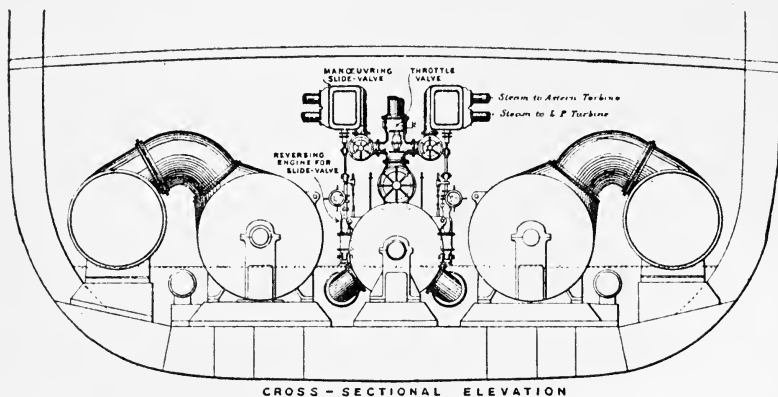
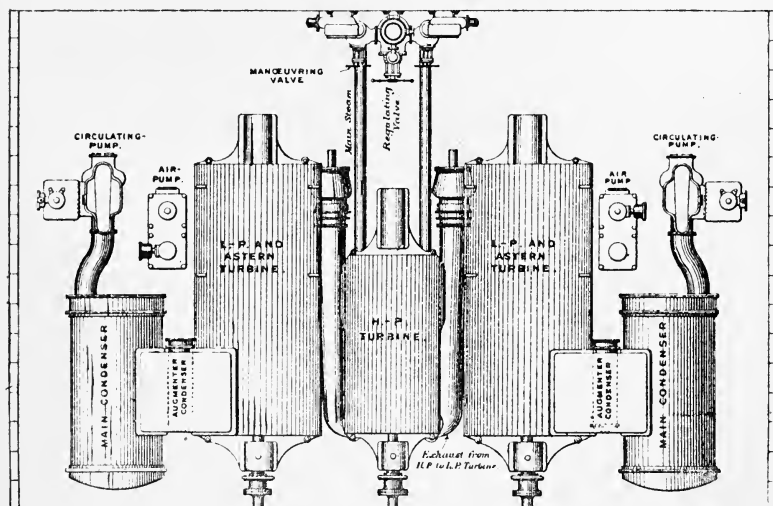

Fig. 137.—Parsons Turbo Pump.

while, when the load is decreased, the main winding loses a portion of its pull owing to the decreased current passing in its coils, and the shunt winding has its current increased, and the admission valve



CROSS-SECTIONAL ELEVATION



PLAN

FIG. 138.—Cross Section and Plan of one arrangement of Parsons Turbines for Steamship Propellers.

is not open for so long. Figs. 137 and 138 show interesting applications of Parsons turbine. Fig. 137 is a turbo pump, and Fig. 138 the arrangement of turbines for driving the propellers of steamships.

## The Willans Turbine Governor

In the Willans apparatus the governor is practically the equivalent of the throttle governor employed in the Willans central valve engine. It is a very powerful centrifugal governor driven by worm gearing from an extension of the main turbine shaft at the steam end, the working parts moving in ball bearings, and the governor merely opens or closes the admission valve more or less, the passage of steam into the turbine being continuous, subject to the amount the valve is open.

A secondary governor is arranged in the Willans apparatus to automatically close the throttle valve should the speed of the turbine exceed a predetermined limit. It should be mentioned that in several forms of turbines, automatic arrangements are provided for preventing the rotor from exceeding its normal speed by more than 10 per cent. It will be understood that at the high speeds at which turbine rotors run, centrifugal force increases very rapidly, and therefore some provision of this kind is necessary to prevent the apparatus being wrecked.

## Lubrication of the Willans-Parsons Turbine

In the Willans-Parsons turbine there is an oil tank under the bearings at the steam end as in the Parsons apparatus, and continuous circulation of oil through the bearings is maintained by a rotary pump driven direct from the turbine shaft. It is claimed that the pump, being always flooded, ensures a complete supply of oil to all the bearings immediately the turbine commences to move. A hand pump is also fitted in the Willans apparatus by which the bearings can be flushed before starting the turbine. It should be mentioned that the question of lubrication of the bearings before starting is an exceedingly important one, and that great care must be exercised to see that the bearings are thoroughly well lubricated before the turbine is started.

## The Brush-Parsons Turbine

The Brush Electrical Engineering Company, who have been engaged in electrical work in the construction of electricity generators, and prime movers for them, since the advent of the Brush machine in the very early days of the electric light, have taken up the manufacture of steam turbines on the lines of the Parsons apparatus. The construction is very similar to that of the Willans-Parsons and that

made by Mr. Parsons' own company. The rotating axle is made of forged steel, machined all over, and the blades are securely held in grooves turned in the axle. In large-sized turbines the axle consists of a cast steel tube. The blades are of hard drawn metal, and those near the steam entry port, which are exposed to high-pressure steam, are specially designed to stand high temperatures.

The control of steam to the turbine is very similar to that in the Parsons. There is an ordinary centrifugal governor, driven by worm and wheel from the main shaft, controlling a small steam relay actuating an equilibrium valve, which is opened for a certain period with each oscillation of the governor. A separate emergency governor is provided, which shuts off the steam when the speed exceeds a certain limit.

The bearings are on the same lines as those of Parsons. For sizes up to 500 K.W. (670 H.P.) the bearing proper is of solid gun-metal, with a series of concentric tubes fitting loosely round it with oil in between. Above 500 K.W. the bearings are of brass lined with white metal. The Brush-Parsons turbine is shown in Plates 18A, 18B, and 18C.

## The De Laval Turbine

The De Laval turbine was the earliest of the velocity turbines. It consists of a disc held upon an axle and having buckets fixed all round the edge of the axle, the whole being enclosed in a case. One side of the case is connected to a condenser, with the aid of which the highest possible vacuum is obtained, and the steam is brought to the other side of the turbine case and is expanded right down to the vacuum pressure, and is allowed to pass through the buckets on the periphery of the disc at the high velocity due to the low pressure, the large volume of steam passing from the other side of the disc to the condenser and turning the disc in the process. The steam is expanded down to the pressures named in the nozzles shown in section in Fig. 139. It will be noticed that the nozzle gradually expands from the throat just beyond its connection to the steam pipe to the edge of the disc. The pressure in the steam pipe behind the nozzle being 200 lbs. per square inch, the pressure at the throat of the nozzle is 110 lbs. per square inch, this being the economical pressure at that point.

The volume of the steam is now increased from 2.8 to 3.5 cubic feet per pound, and its velocity in the throat is 1500 feet per second. At the widest part of the nozzle, where the pressure corresponds to 28 inches of vacuum, the volume of the steam has increased to 256.8 cubic feet per pound, and its velocity to 4127 feet per second. The nozzle continuously diverges from the throat, and the steam is

presented to the wide surface of the disc shown. Several nozzles are fixed to each turbine, and it is arranged to use one, two, or more according to the power the turbine is to deliver. Further, as seen in Fig. 139, which is a complete section of the nozzle and steam entry valve, the admission of steam to the nozzle can be controlled very much as the admission of steam is controlled to an ordinary steam engine.

The velocity of the turbine wheel for high efficiency should be 34 per cent. of the velocity of steam impinging upon the turbine disc, the absolute velocity of the steam when leaving the buckets would then be 34 per cent. of the initial velocity of the steam. It is found in practice, however, impossible to run the turbine discs at the high speeds demanded by this law. With steam entering the turbine case at a velocity of 4000 feet per second, the speed of the turbine wheel should be 1880 feet per second for higher economy. At present

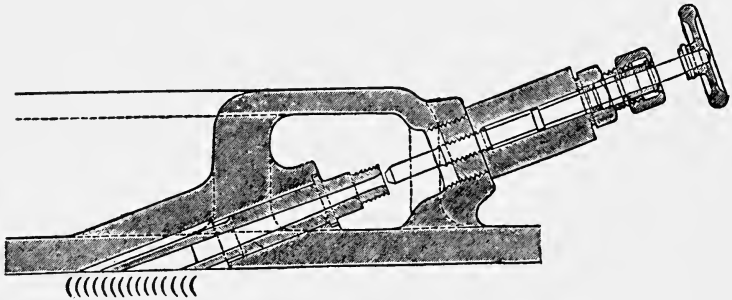

FIG. 139.—Section of Nozzle of De Laval Turbine.

however, the peripheral speed of the turbine wheel does not exceed 1380 feet per second. The difference between the speed of highest efficiency and the highest practical speed makes a difference in theoretical steam consumption of 0.7 lb. per horse-power. That is to say, with the turbine wheel running at the speed of highest efficiency, the theoretical steam consumption per horse-power per hour should be 9.1 lbs., and with the wheel revolving at 1380 feet per second the theoretical steam consumption should be 9.8 lbs. per horse-power hour. These figures are not obtained in practice. The theoretical steam consumptions, it will be understood, are never obtained in actual practice, but the above shows the difference made by the speed of the turbine. Another point in connection with the high speed of the turbine is the matter of balancing. No matter how carefully a high-speed turbine wheel may be turned and balanced, it is practically impossible, so it is found by the makers, to bring the centre of gravity of the wheel exactly in the geometrical centre round which the wheel

revolves, and with the ordinary arrangement of shaft, the vibrations so caused, increasing as they would with the speed, would render it impossible to maintain any bearings, no matter what lubrication was employed, with the high speeds at which the wheel runs. There is, however, a peculiar feature about the apparatus which has enabled the difficulty to be overcome. In place of, as in almost every other kind of revolving apparatus, arranging for the shaft upon which the turbine wheel revolves to maintain its axial line rigid, the shaft is made flexible, by being smaller than would be usual under similar conditions for other work. The vibrations caused by the out-of-balance of the turbine wheel occur with the flexible shaft, and increase with the number of revolutions of the wheel, but at a certain speed, known as the critical speed of the wheel, the vibrations suddenly disappear and the shaft runs smoothly in its bearings. The inventors and makers of the apparatus have termed the phenomenon "the settling of the wheel," and they explain by the fact that at the critical speed the wheel takes a new centre of rotation very near to the centre of gravity, the shaft springing out and allowing it. It is stated that the phenomenon has not been investigated scientifically, but the probable explanation is that, at the critical speed, the number of vibrations and the number of revolutions are equal. The following formula is given for calculating the critical speed:—

$$n = C \sqrt{\frac{P}{Q}}$$

Where P is the force required to bend the shaft a certain distance, Q is the weight of the turbine wheel, and C is a constant. It is stated that the critical speed is from one-sixth to one-eighth of the standard number of revolutions of the wheel.

It will be understood that the speed of the turbine wheel being so very great, the power developed in each individual revolution is very small, and therefore the size of the shaft is enabled to be small, and the flexibility mentioned is thereby provided for. The shaft of a 300 H.P. turbine wheel is only  $1\frac{5}{16}$  inches, and that of a 150 H.P. wheel 1 inch.

## Government of the De Laval Turbine

The De Laval turbine is governed by a sensitive centrifugal governor, mounted horizontally on the end of the gear wheel shaft, with the usual revolving balls, opposed by a spring, and controlling the valve through which admission is obtained by the steam to the steam chest, from which the nozzles that have been described obtained their supply. The governor is practically a throttle governor, and is

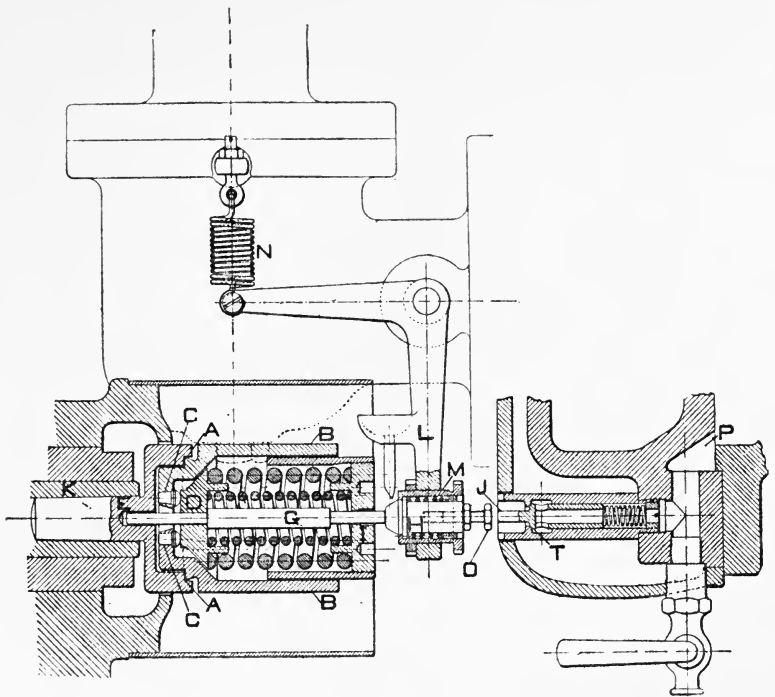

FIG. 140.—Governor of De Laval Turbine. **B B** are the usual weights, which move outwards, compressing the Spring shown, and pushing the Rod **G** over to close the Steam Valve on the right.

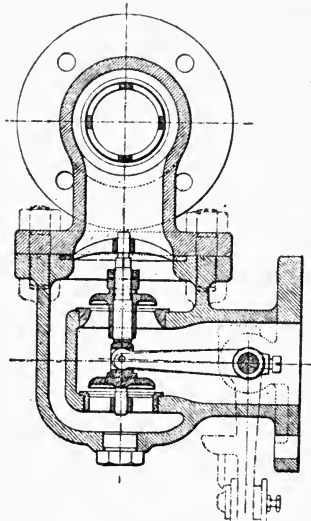

FIG. 141.—Section of Steam Valve controlled by the Governor.



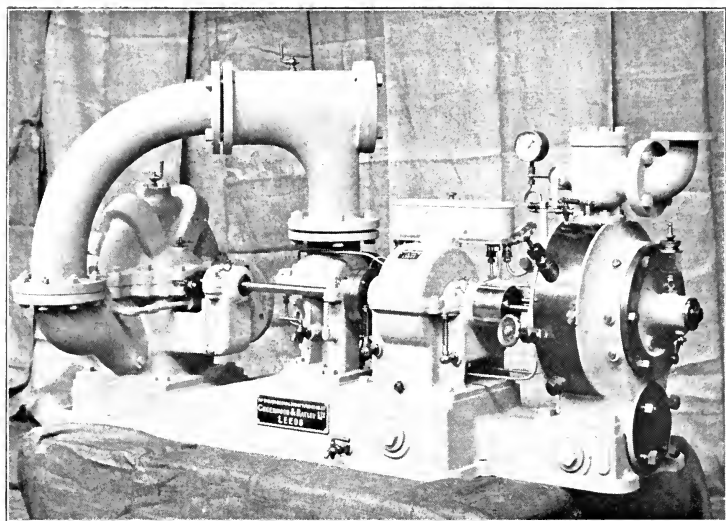

PLATE 21A.—De Laval Turbine directly connected to a 60 Horse-power De Laval Turbine Pump, used for Boiler Feed.

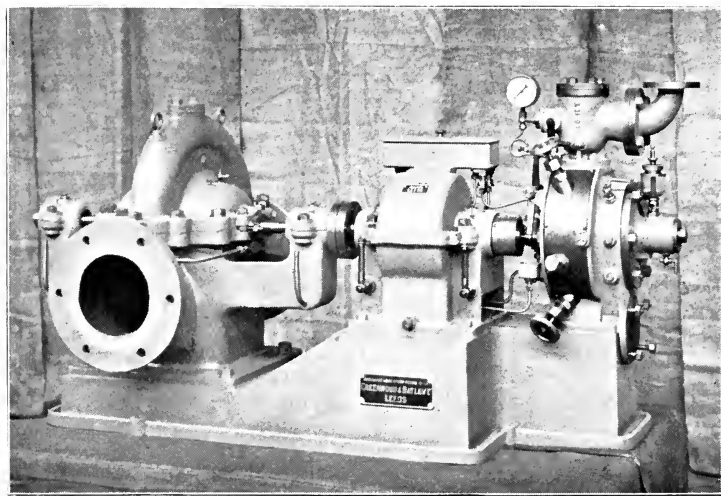

PLATE 21B.—De Laval Turbine directly connected to a De Laval 15 Horse-power Turbine Pump. [To face p. 304.]



stated to maintain the speed between full load and no load within from 2 to 3 per cent. It is shown in Fig. 140, and the valve it controls in Fig. 141.

## Transmitting the Power of the De Laval Turbine Wheel

It will easily be understood that at the very high speeds at which the De Laval turbine wheels run, which are given in the table below, that it is practically impossible to gear them directly to any machine to which the power is to be applied, and therefore the turbine wheel is always sent out with the gearing wheels attached, as shown in Fig. 142, reducing the speeds down to any figure that may be desired. The shaft of the spur wheel of the gearing may carry a pulley for driving any apparatus by belt or ropes, or it may be geared, as shown in Fig. 143, directly to a dynamo, pump, or other apparatus. In Fig. 142 and Plate 20A the turbine is shown transmitting power to two axles, the pinion on the shaft of the turbine engaging with a spur wheel on each side of it.

Plates 20B, 21A, 21B, and 22A show applications of the De Laval turbine to the driving of various apparatus, and Fig. 144 shows the various parts of the turbine.

TABLE XXV.

SPEEDS OF THE TURBINE WHEELS.

Size of turbine.	Middle diameter of wheel.		Revolutions per minute.	Peripheral speed. Feet per second.
	Mm.	Inches.		
5 H.P.	100	4	30,000	515
15 "	150	6	24,000	617
30 "	225	8 $\frac{7}{8}$	20,000	774
50 "	300	11 $\frac{3}{4}$	16,400	846
100 "	500	19 $\frac{3}{4}$	13,000	1115
300 "	760	30	10,600	1378

A very interesting series of tests of a 50 H.P. De Laval steam pump is given in Table XXVI., and further tests of De Laval Turbines with different loads is given in Table XXVII.

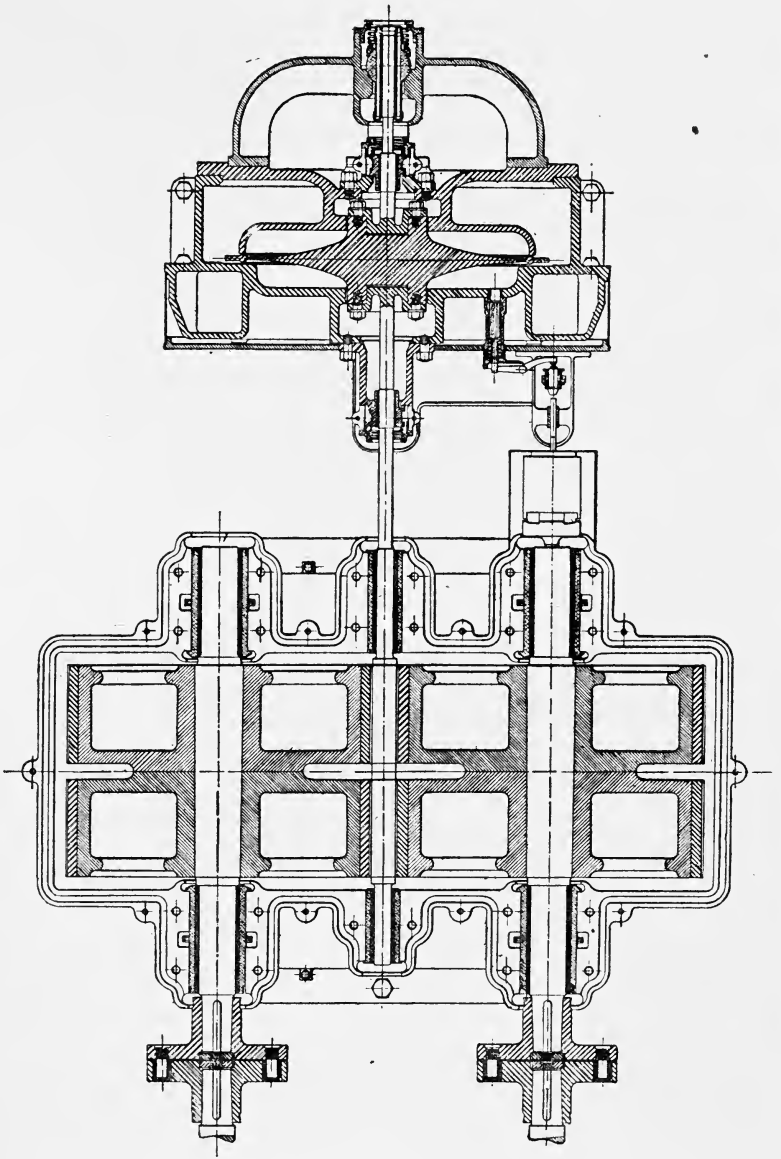

FIG. 142.—Sectional Plan of De Laval Turbine, its Shaft, and two sets of Reducing Gear Wheels, the Spur Wheels being on the two Driving Shafts shown.

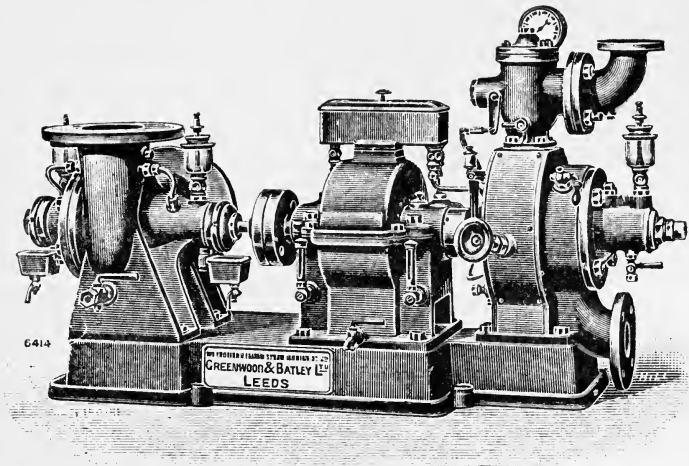

FIG. 143.—De Laval Turbine directly connected to a Turbine Pump.

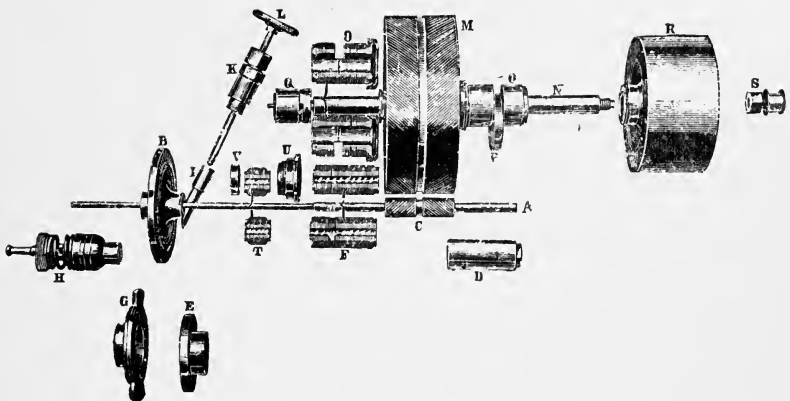

FIG. 144.—Parts of the De Laval Turbine. **B** is the Turbine Wheel; **I** the Nozzle; **A** the Shaft; **M** Gear Wheel, etc.

# 308 STEAM BOILERS, ENGINES, AND TURBINES

## TABLE XXVI.

RESULTS OF TESTS WITH DE LAVAL STEAM TURBINE PUMPS.

Type of turbine pump.	Revolutions per minute.	Height of suction in feet.	Height of delivery in feet.	Quantity of water delivered per second.	Water H.P.	Brake H.P.	Efficiency.
50 H.P. duplex pump coupled in parallel } }	1500	16.4	16.4	Gallons.	37.87	50.3	0.753
				63.5			
50 H.P. duplex pump coupled in parallel. Constructed for larger head of water than the previous } }	1500	16.4	29.53	46.3	38.66	48.0	0.805
50 H.P. duplex pump coupled in series } }	2200	19.7	137.8	123.0	35.22	50.3	0.700
20 H.P. duplex pump coupled in series } }	2315	9.84	85.3	82.5	14.27	20.0	0.713

## TABLE XXVII.

RESULTS OF TESTS WITH DE LAVAL STEAM TURBINES AT DIFFERENT LOADS.

Turbine machine.	Pressure of admission steam. Pounds per square inch.	Vacuum inches of mercury.	Number of nozzles open.	Electrical H.P.	Pounds of steam per electrical H.P. per hour.	Remarks.
50 H.P. turbine dynamo. The test made in April, 1895 } }	113.8	26.3	6	49.4	24.6	Work for condensing included.
	113.8	26.3	5	40.2	25.2	
	93.9	26.9	4	25.0	27.9	
	74.0	27.5	3	12.7	32.5	
100 H.P. turbine dynamo. The test made in June, 1897 } }	103.7	25.8	5	92.7	22.6	Work for condensing not included.
	103.8	26.4	3	55.6	22.7	
	107.4	26.8	2	35.0	24.7	
	106.7	27.9	2	15.5	27.8	

TABLE XXVII. (continued).

Turbine machine.	Pressure of admission steam. Pounds per square inch.	Vacuum inches of mercury.	Number of nozzles open.	Brake H.P.	Pounds of steam per brake H.P. per hour.	Remarks.
150 H.P. turbine motor. The trial made in Nov., 1897	113·8	26·4	7	163·0	17·6	Work for condensing not included.
	116·9	25·9	6	138·4	18·2	
	113·8	26·2	5	114·5	17·9	
	114·3	26·5	4	88·3	18·7	
	112·4	27·0	3	64·1	19·0	
	116·2	25·7	2	37·5	22·3	
300 H.P. turbine motor. The test made in Dec., 1899	192·7	27·3	7	303·6	14·1	Work for condensing not included.
	196·3	27·6	6	255·5	14·7	
	196·3	27·6	5	216·9	14·4	
	196·3	27·6	4	172·6	14·5	
	190·6	27·8	3	121·6	14·9	
	196·3	28·1	2	74·2	17·2	
	213·3	28·5	1	31·5	21·6	
300 H.P. turbine motor. The test made in June, 1900	126·6	26·98	8	337·45	15·68	Work for condensing not included.
	126·4	26·99	7	293·7	15·76	
	125·0	27·24	6	249·1	15·92	
	125·0	27·62	4	162·7	16·25	
	125·0	27·91	3	118·9	16·70	
	125·0	28·16	2	73·5	18·00	
	125·0	28·25	1	30·4	21·77	

Messrs. Greenwood & Batley, the makers of the De Laval turbine, recommend the ejector condenser for use with their apparatus, and when a central condenser is employed, they require that a vacuum governor shall be inserted in the pipe between the condenser and the turbine.

### The Curtis Turbine

The Curtis turbine is a modification of the De Laval, arranged primarily to reduce the speed of the revolving wheel. It consists really of several turbines, usually fixed vertically, one above the other, each turbine consisting of moving and stationary discs, both carrying buckets on their peripheries similar in form to those of the De Laval apparatus. The separate stages, as they are called, are divided by diaphragms, through which the steam passes, each diaphragm having a set of steam nozzles, somewhat similar to those of the

De Laval, the steam nozzles of the upper stage, where the steam first enters the apparatus, being directly in connection with the steam chest. The steam passes through the buckets of the upper disc in each stage, and then through the buckets of the stationary disc. From Fig. 145, which shows two stages, it will be seen that the steam passes from the nozzles directly into the moving buckets, without changing its curves appreciably, on entering; that it passes out as the buckets move on, also with little appreciable change of course; that on reaching the stationary buckets it enters them also without changing its course, but that its course is reversed in passing

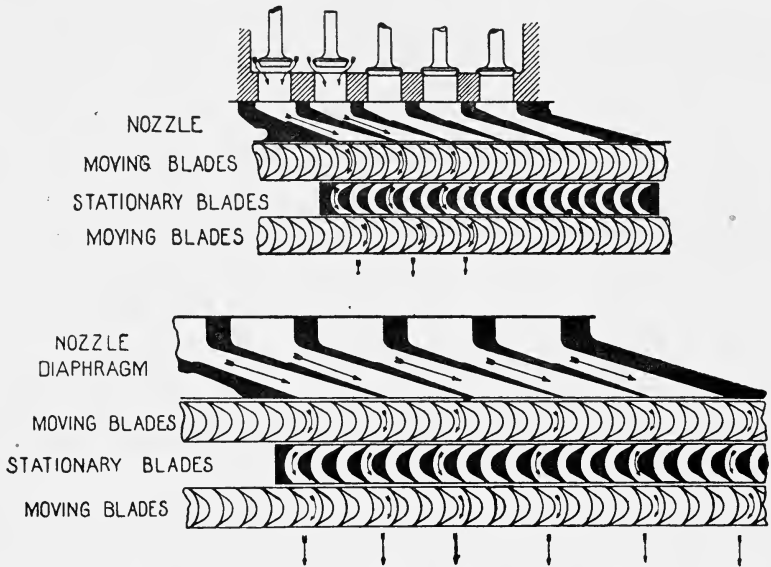

FIG. 145.—Section of Part of Curtis Turbine, showing two Stages. The Nozzles are shown inclined, the stationary buckets dark and the moving blades light.

through the stationary buckets, and that it is then presented to the moving buckets of the next disc in the proper direction to enter them without change of course.

The steam is brought comparatively to rest after passing through the last moving bucket of each stage before passing on to the next stage. The diaphragms between the stages are steam-tight, except where the nozzles open into them as shown.

The early forms of Curtis turbine were made with horizontal shafts, but all the later ones have been made vertical; and the usual arrangement now is: The turbine is mounted above the condenser, a



vertical shaft passing through the whole apparatus, on to a footstep bearing, consisting of two bearing blocks, one of which rotates with the shaft, the other being fixed to the foundation. Water is forced up through a hole in the stationary part of the bearing out between the two surfaces in contact in a thin film, and it afterwards passes upwards to lubricate a guide bearing, and thence passes into the turbine base, from which it is removed with the condensed steam. The water for the bearing is supplied by a small pressure pump and hydraulic accumulator, the power used being stated to be 1 H.P. for a 1000 H.P. set, and 2 for a 2000 H.P. set. The upper bearings are lubricated by a small oil pump worked from the shaft of the water pressure pump, the oil being returned to an oil tank from the bearings, and used over and over again. It will be evident that the upper bearings being merely guides, so long as the apparatus is in balance, lubrication of them does not present so difficult a problem as that of horizontal shafts.

### Governing the Curtis Turbine

The governor of the Curtis turbine is practically a throttle governor of the usual centrifugal type, with moving balls, etc. An emergency governor is also provided for cutting off the steam if the turbine exceeds a certain figure.

The governor is connected to an electrical controller, which opens or closes a series of electro magnets, operating pilot valves, which open or close the main steam valves, the latter being of the balance type.

Where the Curtis turbine is employed for driving dynamo machines, it is usual to fix the dynamo above the turbine, as shown in Fig. 146, and, as explained, the condenser below, the vertical shaft being practically continuous throughout the apparatus.

The makers of the Curtis turbine recommend surface condensers, and with sets of 500 K.W. (670 H.P.) and upwards, that the condenser shall occupy the space below the turbine, the pumps being worked from the turbine shaft.

Several claims are made for the Curtis turbine, one of which, in particular, is the fact that very much smaller floor space is required. As against this, makers of horizontal turbines and of reciprocating engines point out that the foundations must be stronger, and usually, therefore, carried down much deeper than is necessary with horizontal apparatus, either reciprocating or turbine.

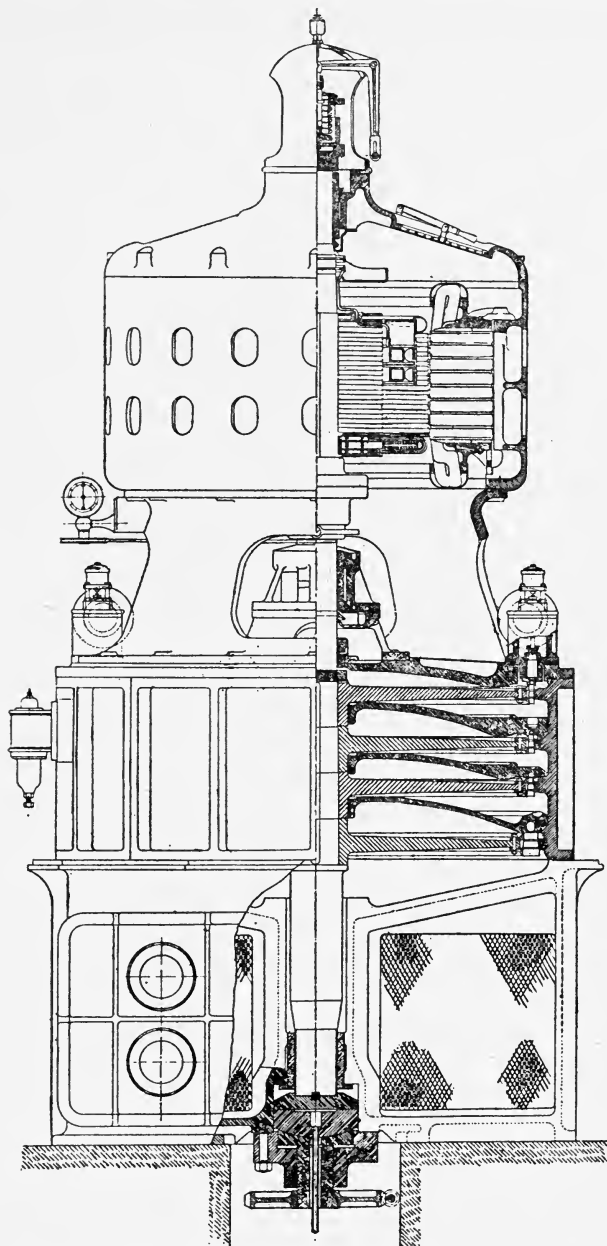

FIG. 146.—Sectional elevation of Curtis Turbine, with Dynamo above and Condenser below.

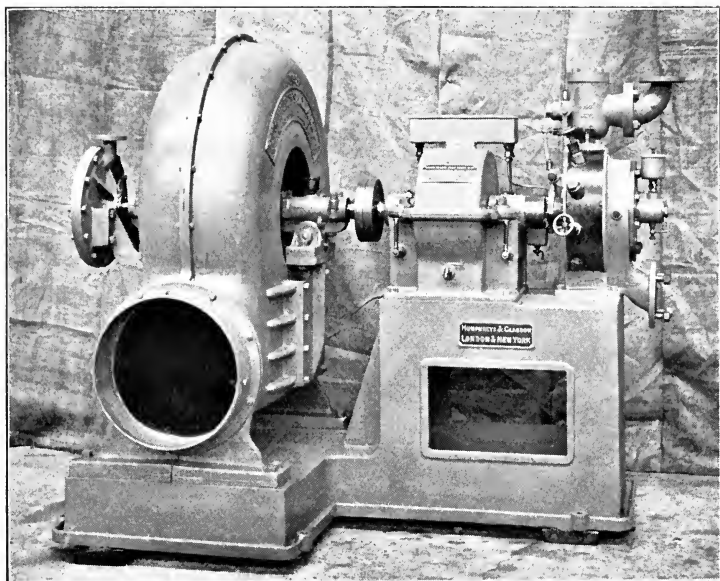

PLATE 22A. —De Laval Turbine directly connected to a Fan.

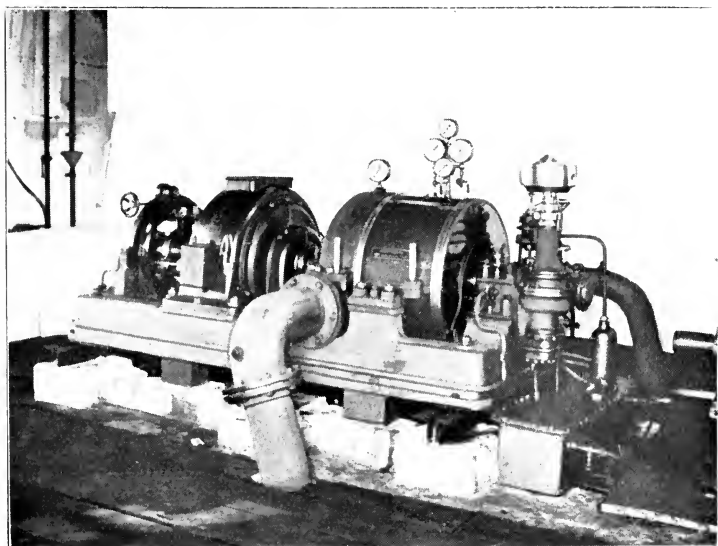

PLATE 22B.—A Zoelly Turbine, made by Escher, Wyss, & Co.  
[To face p. 312.]



## Test of a 1500 Kilowatt Curtis Turbo Generator

The following test of a 1500 K.W. Curtis turbo generator, made for the Corporation of London Electric Supply Company, will probably be interesting. The turbines were of the four-stage type, the condenser occupying the space below the turbine, and the dynamos being fixed above, the overall height from the condenser base to the governor above the dynamo being 19 feet 6 inches, and the floor space 15 feet  $\times$  14 feet. A portion of the apparatus was fixed below the engine-room floor, so that the height from the engine-room floor to the top of the governor was 14 feet 6 inches. The condenser was of the surface type, and had a cooling surface of 4000 square feet, the air pumps being of the three-throw type, with 15-inch cylinders by 8-inch stroke, driven by a 15 K.W. electric motor. The centrifugal pump was driven by a 30 K.W. motor. The turbine footstep bearing was provided with water from the well at a pressure of 400 lbs. per square inch by three-row bucket pumps, driven by 2 K.W. motors. The steam pressure was 150 lbs. per square inch, the steam was superheated 60° F, and the vacuum was 29 inches, with a barometer at 30.15 inches. The consumption of steam was 17 $\frac{1}{4}$  lbs. per K.W. hour, at full load, and 20 lbs. per K.W. hour at a third of full load; or 12.44 lbs. per horse-power hour at full load, 15 lbs. per horse-power hour at one-third load.

The steam taken by the auxiliaries brought the total consumption up to 13.32 lbs. per horse-power hour at full load. It will be seen that the Curtis turbine, though it is strictly a velocity turbine, is also partly a pressure turbine, inasmuch as the expansion of the steam is performed within the turbine itself. Figs. 147 and 148 show the apparatus tested.

## Westinghouse Turbine

The Westinghouse Company, as the author understands, make two forms of turbines, one on the lines of the Parsons turbine, and as made by the other makers that have been described, and the other apparatus which is a combination of the Curtis and Parsons turbine. The latter form is fixed at the Lots Road generating station on the Metropolitan District Railway in London, and is arranged for furnishing 5500 K.W. (7330 H.P.) each, driving three-phase generators.

The turbines are arranged with their shafts horizontal, and the steam is delivered to the middle of the apparatus. The Curtis portion of the turbine receives the steam first, and the Parsons apparatus afterwards. There is only one stage of the impulse turbine on each side of the entry port, the steam entering at 160 lbs.

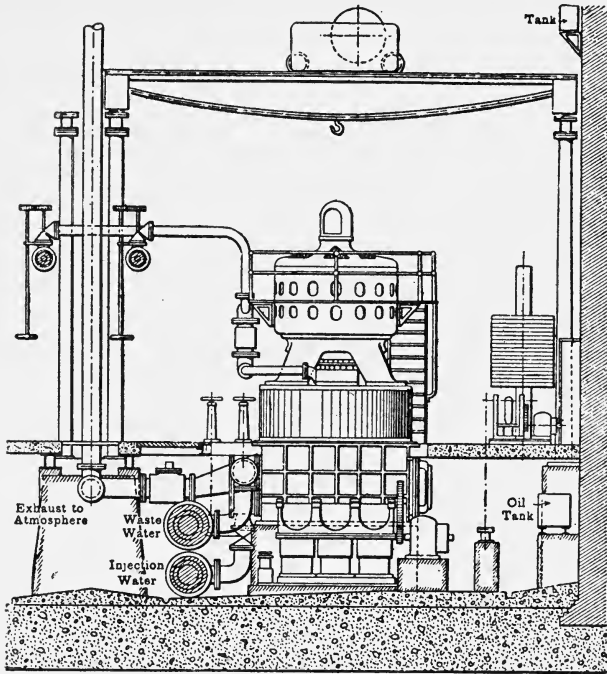

FIG. 147.—Elevation of a Part of an Electricity Generating Station, with Curtis Turbine, Dynamo, Condenser, and Accessories.

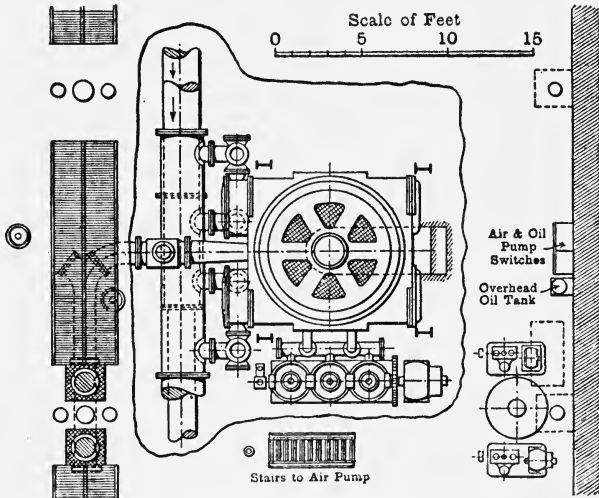

FIG. 148.—Plan of the Portion of Electricity Generating Station shown in Fig. 147.

pressure, and being expanded down to 60 lbs. before entering the pressure turbine. The impulse turbines consist of nozzles for expanding the steam, then rows of guide buckets and revolving buckets, the steam then passing on to a receiver, for the remaining portion of the turbine, in which it is expanded down to condenser pressure. There are in the pressure portion of the turbines three rows of turbine wheels, with brass vanes, and with the usual stationary vanes between on each side. The arrangement enables the whole apparatus to be made very much shorter for the power that is employed, than is usual in the ordinary form of Parsons, or impulse turbines.

The difference between working with the condenser and without at Lots Road is, the author understands, 60 per cent.

### The Rateau Turbine

The Rateau turbine, made by Messrs. Fraser & Chalmers, is also a velocity or impulse turbine, but like the Curtis, it also has a

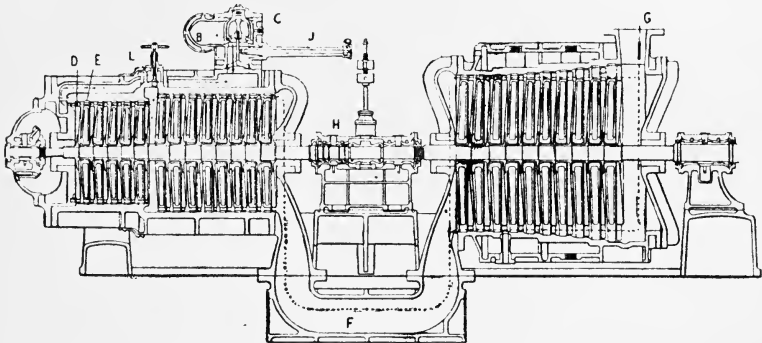

FIG. 149.—Section of one Form of Rateau Turbine. Steam enters on the left and is gradually expanded down, as it passes through the different stages.

number of moving, and of fixed elements, the expansion of the steam being performed partly in the turbine itself. The apparatus consists of a containing cylinder, usually fixed horizontally, and somewhat similar to those that have been described in connection with the Parsons turbine. The moving and stationary portions of the apparatus are also constructed something on the lines of the Willans. The vanes are mounted on the peripheries of steel discs, the moving discs being fixed directly on the axle, and the stationary discs being fixed on the inside of the containing cylinder, and closely

embracing the shaft, which passes through them in collars of anti-friction metal. The fixed discs are called diaphragms, and their office is said to be the distribution of the steam to the moving discs. The steam passes first through the vanes of the diaphragms, and is directed by them on to the vanes on the moving discs, so that the direction of the steam is not changed on meeting them, the steam then passing from the moving disc to the vanes of the next diaphragm, where its course is directed so as to meet the vanes of the next moving disc in the proper direction, and so on. There is a distance of about  $\frac{3}{16}$  inch between the moving and fixed portions of the Rateau turbine, this construction having been adopted to reduce chances of dangerous friction, and the possibility of breakdown. It is claimed that there is no longitudinal thrust on the moving part, and therefore there is no necessity for apparatus to balance that thrust. The Rateau turbine is sometimes made in two portions, as shown in Fig. 149, the high-pressure steam entering at one end, as shown, passing through the first portion of the apparatus, which, it will be seen, is divided, very much as in the early Parsons turbine, and afterwards passing through the low-pressure apparatus, as shown in the figure.

The governor is of the usual centrifugal type, controlling the admission valve to the steam chest.

### The A.E.G. Steam Turbine

The A.E.G. steam turbine is an impulse or velocity turbine, with two stages only, and its axle runs horizontally. Its construction is shown in Fig. 150, in which the two stages and the revolving wheels can be seen. The steam enters the turbine by the main throttle valve, passing through a steam separator into the steam chest, then through nozzles of a form similar to those that have been described on to the first stage of the moving buckets. After passing through the first lot of the moving buckets, it passes through a ring of fixed buckets, its direction being arranged in passing through them, so as to enter a second set of moving buckets at the proper angle. After passing through the second moving wheel it enters an intermediate receiver, passing from there through a second set of nozzles, and through the moving buckets, and guide buckets of the second stage.

When running non-condensing, it is arranged that only part of the steam enters the second stage of the turbine, the remainder being exhausted directly to the atmosphere.

The turbine wheels are constructed of specially selected steel, and the buckets of a special bronze. The buckets are dovetailed into the turbine wheels, and the turbine casing is made of cast iron.



The steam is expanded to about atmospheric pressure in the first stage, and down to condenser pressure in the second stage.

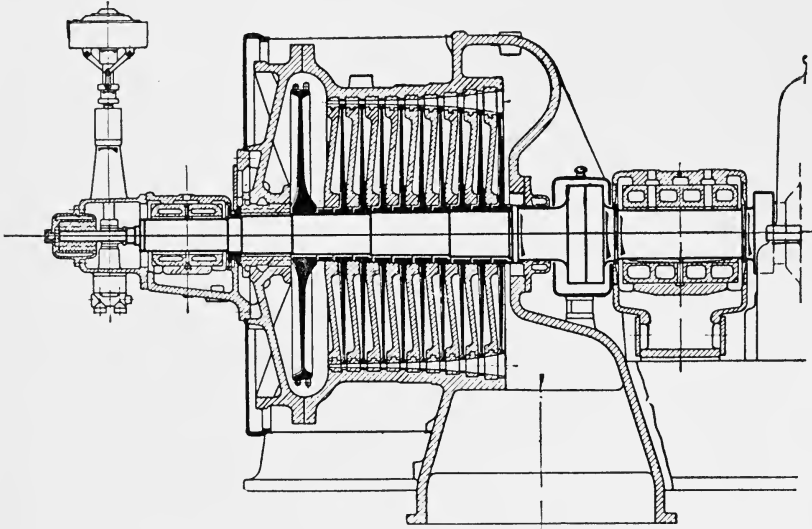

FIG. 150.—Section of one Form of the A.E.G. Steam Turbine.

## The Zoelly Turbine

The Zoelly turbine is also an impulse or velocity turbine, but with a number of stages, the inventors claiming that better results are obtainable by dividing up the work into a number of stages, as it enables the velocity of the steam to be reduced, and thereby reduces the wear upon the turbine blades. The Zoelly turbine for large sizes is made in two portions, as shown in Fig. 151 with a bearing between the two, the high-pressure portion being at one end and the low pressure at the other. The whole apparatus is arranged horizontally, the turbine wheels rotating in vertical planes. Each half of the apparatus is also divided longitudinally into two, the upper half lifting off, so that the wheels can be got at for inspection. There are the usual guide wheels, dividing the turbine up into chambers, as in the Rateau and others that have been described. The guide wheels consist of discs fixed to the inside of the containing cylinders, and with vanes fixed near their peripheries, for the guidance of the steam in the usual manner. The moving wheels or runners consist of wrought-steel discs, accurately turned and balanced and

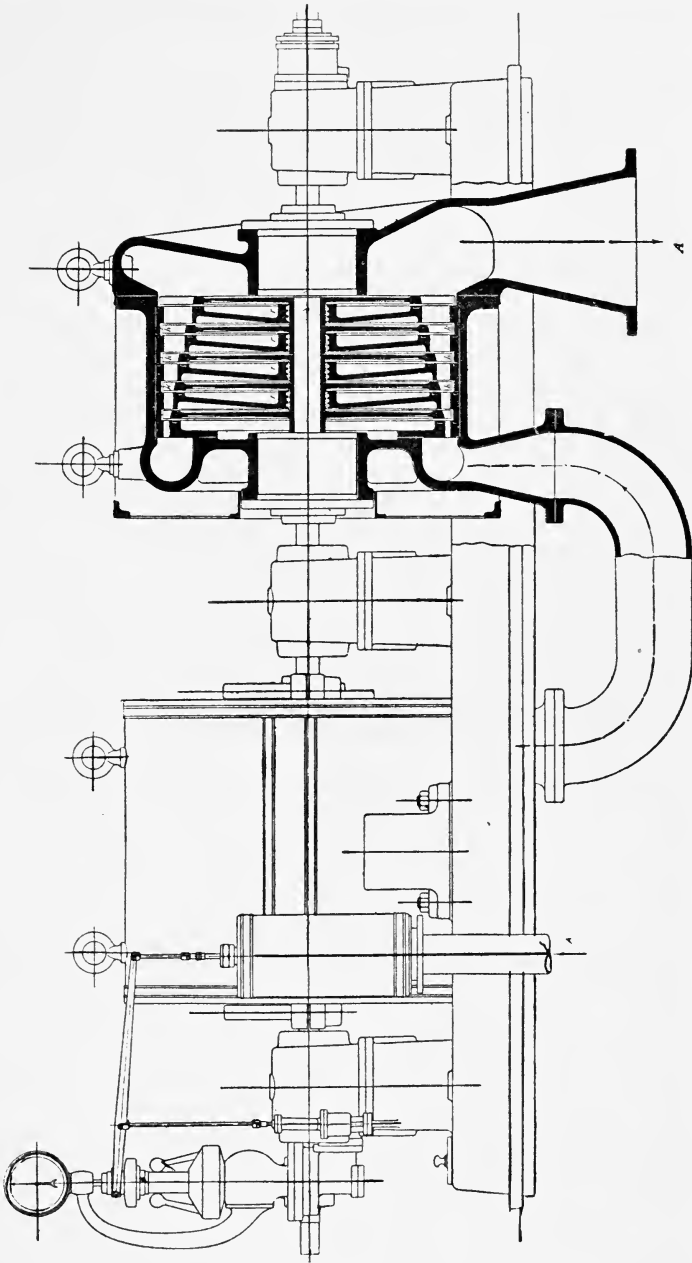

FIG. 151.—Drawing of the Zoelly Turbine, as made in the larger sizes, in two Parts. Steam enters on the left, where the Governor is shown. The Low-pressure Portion, on the right, is shown in Sectional Elevation.

machined all over, provided with a groove in their peripheries, in which their blades are fixed. They are shown in Figs. 152, 153.

As in the other forms of impulse turbines, the runners revolve in the chambers formed by the guide blades, the latter directing the steam on to the vanes of the runners in the proper direction.

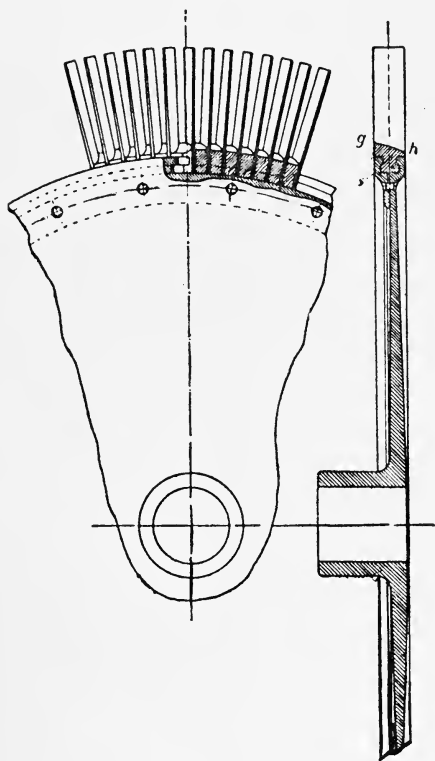

FIG. 152.—Runner of Zoelly Steam Turbine, in Plan and Elevation.

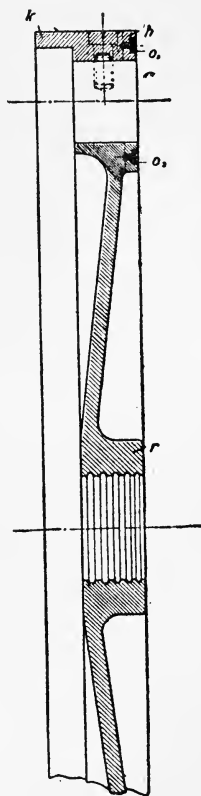

FIG. 153.—Stationary Blade of Zoelly Turbine.

The clearance between the rotating and stationary parts of the apparatus, in the larger sizes, is  $\frac{1}{4}$  inch.

The bearings, as will be seen in Plate 22B, are supported by the bed plate, and are claimed not to be subject to heating from the steam casing. As in other forms of impulse turbines, the axle is supported throughout its length by the collars in the centres of the guide-rings.

The governor, a section of which is shown in Fig. 154, consists of an oil relay, working with a pressure of oil of 90 lbs. per square inch, which works the main steam valve, and which is itself controlled by a smaller valve, shown to the left in the figure, worked by the governor. In the drawing the governor is seen on the extreme left, with the usual balls arranged to rotate in the usual manner, and giving motion as they rise and fall to one end of a lever, to which are attached rods, moving the small controlling valve of the oil system, and the oil relay and main steam valve. As the governors rise and fall, oil

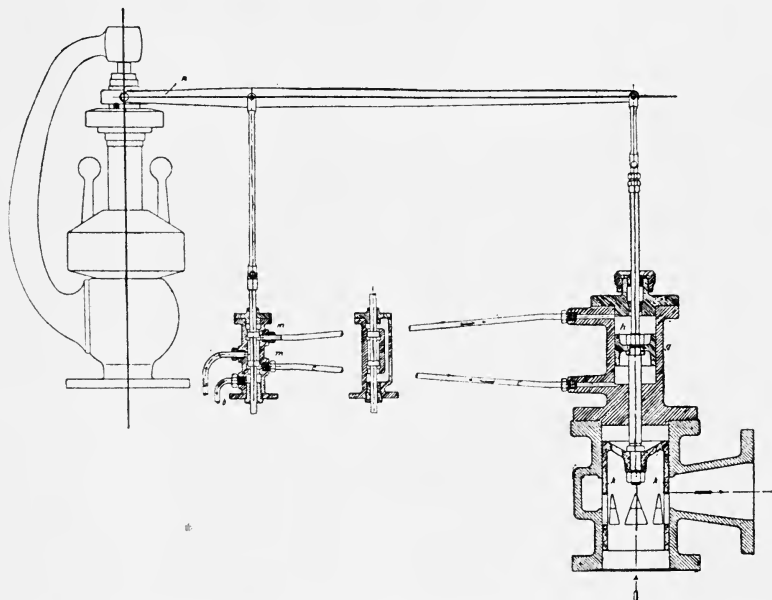

FIG. 154.—The Governor of the Zoelly Turbine. The rising and falling of the Governor Spindle moves the Arm of the Lever shown, up and down, its other Arm working the Oil Relay, which in its turn moves the Valve below. A Transverse Section of the Oil Relay is shown in the middle of the figure.

is admitted through the small controlling valve, to the oil relay, lifting it, and with it opening the steam valve, or closing it, according to the load that is on the turbine. The oil, after passing through the relay, returns to the oil tank, through the small control valve, and is pumped up again.

The steam passes continuously into the turbine, the steam valve being opened to a certain definite distance, corresponding to each load on the turbine.

There is an emergency governor, which shuts off the steam if the speed exceeds 10 per cent. above the normal.

There is also an overload valve arranged to obtain additional power for temporary purposes, and to obtain full power when the turbine is working non-condensing, by the admission of full-pressure steam to the later stages of the turbine.

## The Hamilton Holzwarth Steam Turbine

This apparatus, which is made by the Hooven Owens, Rentschler Co., of Hamilton, Ohio, U.S.A., has certain special features that are of interest. For apparatus of 1000 H.P. and upwards the turbine is divided into two portions, for high- and low-pressure steam. For apparatus below 1000 H.P. the turbine is in one casing. The turbine casings, pedestals for bearings, and for the electricity generator, when the turbine is employed for driving it, are fixed upon a bed plate of the box pattern, very much on the lines of the Zoelly, and on the lines adopted in the case of Lancashire mill engines, and other large engines of that type. All steam, oil and water piping, including the steam inlet and bye-pass valves, are carried in the bed plate below the level of the turbine. A steam separator is fixed in the bed plate, and the steam passes through it to the main inlet valve, from which it passes through a regulating valve to the high-pressure turbine. The turbine is on the lines of the Parsons, the stationary wheels being held on the inside of the cylinders, as usual, and extending very nearly to the axle. The stationary discs are fixed in grooves in the turbine casing, the vanes being riveted to the discs, and being of drop forge steel, fixed in grooves, on the outside peripheries of the discs. The running wheels are built up, it is claimed, of great strength. Cast-steel hubs are fixed on the axle, steel discs being riveted to both sides of the hubs, forming circumferential ring spaces in which vanes are held by means of rivets, the outer edge of the vanes being held by a thin steel band.

The bearings are of the ordinary split pattern, lubricated by oil under pressure. The governor is of a special form, driven directly by worm gearing from the turbine shaft, and it actuates a double-seated poppet valve.

The governor shuts off the supply of steam, if the angular velocity reaches a point  $2\frac{1}{2}$  per cent. above the normal, and opens it more or less in proportion to the steam required for the work in front of the turbine.

Lubrication is very similar to that in the Parsons turbine. A portion of the bed plate is formed into an oil tank, and an oil pump, driven by worm gearing from the turbine shaft, forces the oil through the bearings, from which it flows back to the tank, a valve enabling the pressure of oil to be regulated.

## The Forms of Buckets and Blades of Steam Turbines

There is not space within the limits of this book to give full particulars for the mathematical calculation of the forms, sizes of buckets and vanes of steam turbines, but the following may be of service. The design of both buckets and vanes must follow certain lines. One is, the steam—and the same rule applies more forcibly with water—must impinge on the bucket or vane without shock. If steam or water impinges upon a surface in such a manner as to be thrown back, or broken up by the impact, a large portion of the work it is capable of doing is lost, and therefore all forms of buckets or vanes are designed so that the water or the steam glides into them, and passes through them, with as little friction or shock as possible, passing out of them in the same manner, but with as small an amount of energy remaining, that is to say, with as low a velocity as possible. This applies, of course, where the whole of the energy is to be taken out of a moving stream of water or steam by one ring of buckets or vanes. Where the steam is to pass through a succession of rings or buckets or vanes, each ring is designed to take out its own particular portion of energy, passing the steam on to the next ring, and so on.

In order that the steam or water may follow the above rules, it should enter the bucket or vane tangentially, and leave it tangentially. Put in another way, the direction in which the steam enters the bucket or vane should be a tangent to the curve formed by the bucket or vane at the point where the steam or water enters, and the direction in which it leaves the bucket or vane should be a tangent to the curve of the bucket or vane at the point of exit. It must not be forgotten, of course, that the bucket and the vane are both moving, and that the line of the curve of either is not the same when the steam or water enters, as it is when it leaves. These points have all to be calculated, or set off by graphic methods.

Another point in connection with both water and steam is, as mentioned above, the velocity or the energy possessed by the steam on leaving should be as small as possible. On the other hand, a certain amount of energy is necessary to be left in the case of water, or it cannot get away from the turbine wheel; and in the case of steam, a certain amount of energy remains, because the whole of the energy cannot be taken out of the steam by any known method.

### Turbines Working with Exhaust Steam

To Professor Rateau is due the credit of the idea of working steam turbines by the exhaust steam from engines that are working

intermittently, such as the winding engines at collieries, the rail-mill engines at iron works, and others; but other makers of turbines have taken up the idea, and there is no reason, so far as the author is aware, that any one of the turbines on the market should not be applied to the same use, provided that proper arrangements are

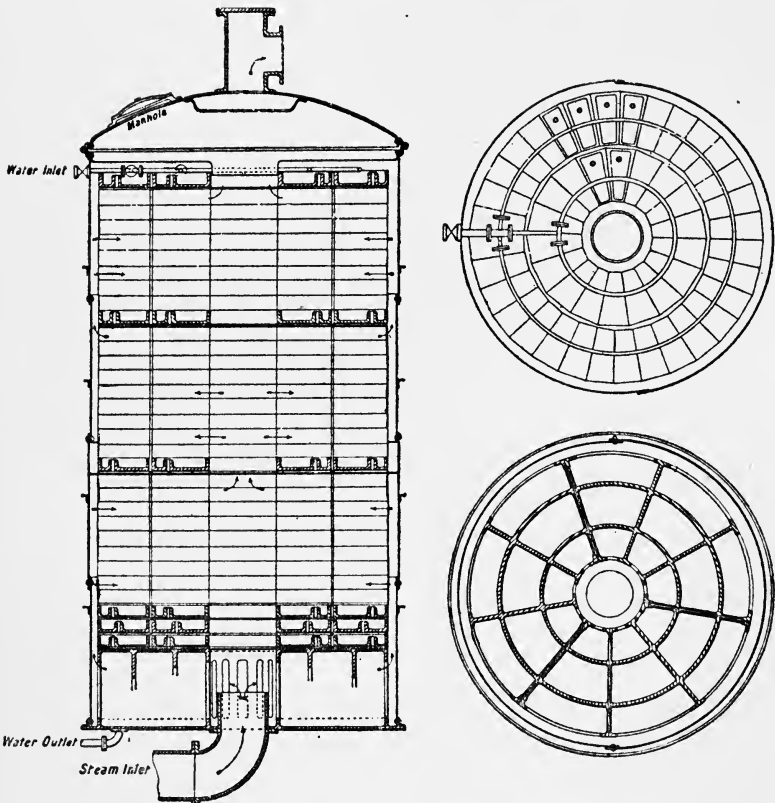

FIG. 155.—One form of Professor Rateau's apparatus for storing the heat from the Exhaust Steam of irregularly running Engines, for use in Turbines. The Cast-iron Traps, shown on the right, are held inside the Vertical Cylinder, shown on the left.

made. The Zoelly turbine, for instance, has been adopted for work of the kind at Rombach near Metz, where two 900 B.H.P. turbines are running electricity generators, fed with exhaust steam.

The reason of the adaptability of turbines for working with exhaust steam, is the fact pointed out several times already, that the largest portion of their work is obtained on the lower part of

the steam scale. As the exhaust steam from intermittently working engines is irregular, it is necessary that some arrangement shall be provided for storing the steam, or the heat present in the steam, during the times of large exhaust, so that the surplus at those times can be utilized to make up for the deficiency during the times when the engines are standing. The turbines can, of course, be employed for working with exhaust steam from regularly running engines, such as fan engines, the blast engines of blast furnaces, and others; and it is a question, in those cases, whether more is gained by employing the exhaust steam in a turbine, or sending it to the condenser directly. Where condensation is not practicable from one of the causes that have been mentioned, there can be hardly any doubt of the economy of utilizing the exhaust in a low-pressure turbine.

Professor Rateau has worked out several methods of storing the heat of the surplus steam, some of which are shown in Figs. 155 and

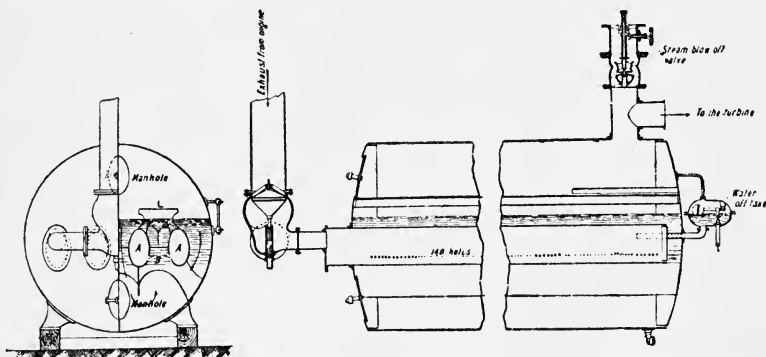

FIG. 156.—Another form of Rateau's Heat-storage Apparatus. The Steam passes into the Water surrounding the Elliptical Pipes shown, through holes in the Pipes, causing circulation of the Water, etc.

156. The apparatus are really heat accumulators, and the arrangements are all designed to store the whole of the surplus heat coming over in the exhaust steam, and to give it up readily when the engines, from which the exhaust is taken, are standing. One form consists of a number of cast-iron trays, with water in them, standing in a vertical cylindrical chamber. This arrangement is shown in section in Fig. 155. The exhaust steam enters at the bottom of the apparatus, and the steam that is required for the turbine that is working from it leaves at the top. Water is supplied to the apparatus, when required, by the pipe shown, and can be run off as required.

Another arrangement consists of a cylindrical shell, such as that of an old Lancashire boiler, usually fixed horizontally, partially



filled with old iron rails. The exhaust steam from the engines enters the old boiler, as in the other case, passing out at the opposite end to the turbine, and any steam that is not required for the turbine gives up its heat to the iron rails. In another method, one or more cylinders are arranged horizontally, about two-thirds full of water, and have elliptical-shaped pipes, as shown in Fig. 156, arranged inside of them, very much on the lines of the flues of a Lancashire boiler, the pipes being pierced with a large number of holes. The exhaust steam passes into these pipes, and from them to the turbine, a quantity of the steam, however, passing out through the holes in the pipes, and causing a violent circulation of water within what is practically a steam boiler.

In either arrangement the heat is stored in the water or the iron, the temperature of the water and the iron being raised in consequence, and the water being prevented from evaporating by the steam pressure within the accumulator, so long as there is plenty of steam to feed the turbine. When the supply of steam from the exhaust of the engines fails, the pressure of the steam within the accumulator being lowered, the temperature of evaporation of the water is also lowered, as explained in Chapter I., steam comes away, passes to the turbine, and provides the necessary supply to keep it running.

It will be evident that it is not possible to obtain the full value of the whole of the exhaust steam, since some must be kept for storage, but a large percentage is obtained, and results in considerable economy. The apparatus has been applied to several collieries and iron works on the Continent, and to a few collieries in the United Kingdom. The impulse turbine of Professor Rateau is claimed to be better for this purpose than the pressure turbine of the Parsons type, but it appears to the author that, providing the turbine is constructed for the lower pressures, either apparatus should answer equally well.

An adjunct of the arrangement that has been adopted in some cases, is a connection to the boiler furnishing steam for the engines, the steam from the boiler being automatically turned on to the turbine, should the quantity of steam available in the accumulator fall below a certain figure. The arrangement includes a thermostat working a differential valve, the valve remaining closed so long as the pressure on the turbine side of it reaches a certain figure, viz. that sufficient to keep the turbine going. Should the pressure on the turbine side of the differential valve be lowered to such a point that the turbine would tend to slow, the differential valve comes into operation, and opens the connection directly to the boiler, the turbine then working directly with live steam until the accumulator has sufficient storage to keep it going. It is a question whether it is more economical to work the arrangement in this manner. By the aid of the supply from the boiler, the heat accumulator can be

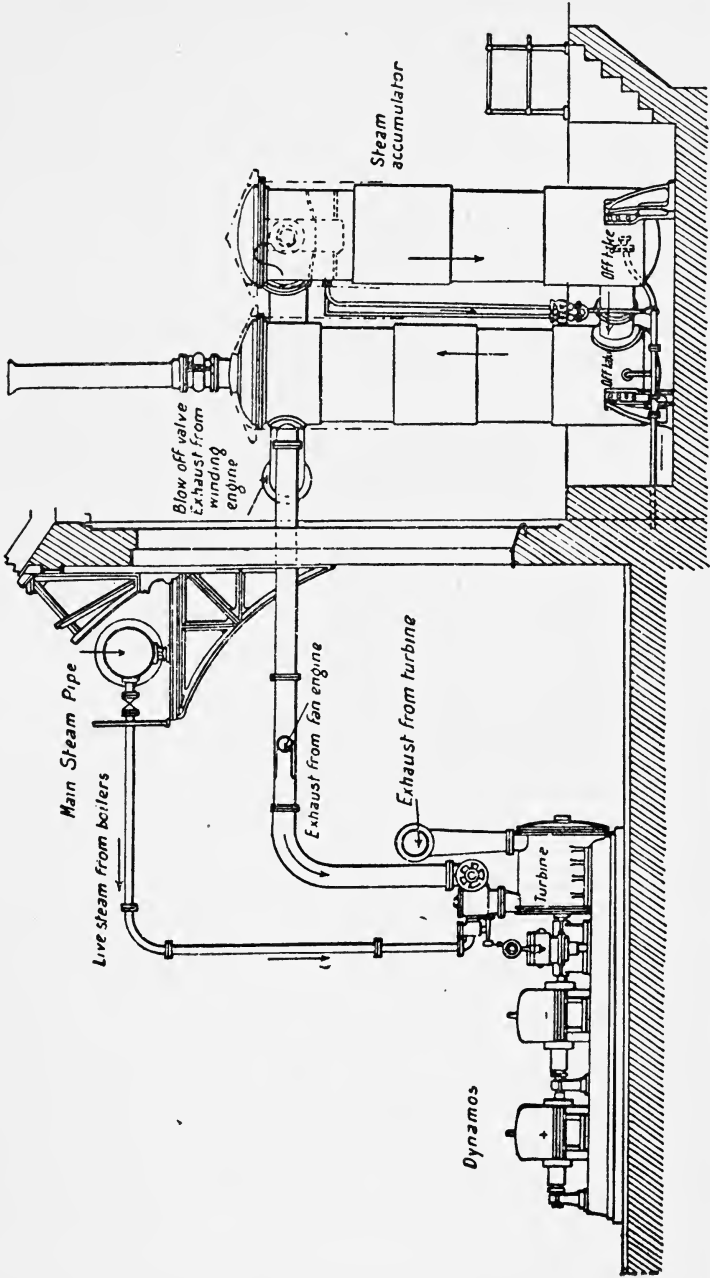

FIG. 157.—Diagram showing the arrangement of Steam Plant, at Bruay Colliery, Pas de Calais, in which Professor Rateau's thermal storage method is employed. The Exhaust Steam from the Winding Engines is used in a Turbine to drive a couple of Dynamos, assisted by live Steam from the Boilers when required.

of smaller size than when it is to provide the whole of the steam required, and the whole of the exhaust steam can be used. It is again a question of the balance sheet, as in all these cases. There is the cost of the additional steam taken from the boiler, the interest on the additional apparatus required, the cost of looking after the apparatus, as against the cost of the additional size of the accumulator.

It appears to the author, also, that Mr. Druitt Halpin's system of thermal storage should be applicable in this case. Mr. Halpin's apparatus consists of a boiler shell, without tubes or furnaces, partially filled with water, the exhaust steam or the surplus live steam from any boiler plant being taken to the thermal storage tank, where it is turned into the water, heating it to a temperature corresponding to that of the steam, the water being used afterwards for feeding the boilers. It will be obvious that the same arrangement as rules with Professor Rateau's apparatus, would rule in Mr. Halpin's, if proper arrangement is made. There is always a steam space within the boiler shell, as in Professor Rateau's arrangement, and it should be easy to take steam from the thermal storage tank in place of water. As the water would be raised to a temperature considerably above that of the low-pressure steam employed in the velocity turbine, this, it appears to the author, should be able to be obtained by any arrangement providing for storage of steam and water, in which the temperature of the water was raised above the ordinary temperature at which steam evaporates under ordinary atmospheric pressures.

## Turbines and Condensing

As explained in Chapter I., the heat that can be extracted from the steam is as large between the ordinary atmospheric pressure and 29-inch vacuum, as between a pressure of 83 lbs. absolute and atmospheric pressure. In reciprocating engines, as explained, the full steam scale cannot be utilized, because the volume of the steam increases so very rapidly, after atmospheric pressure is passed, and particularly on the lower portions of the scale, that the engine cylinders to make use of it would have to be so very large that the advantage would be lost. In reciprocating engines, 25-inch vacuum is the limit at which condensation is economical, and then only providing the other points that have been mentioned are favourable. With turbines, however, it is a very simple matter to increase the size of the cylinder in which the turbine revolves, and the turbine rotor, and therefore the steam can be utilized at as low a pressure, and as large a volume, as can be obtained. Hence, condensing is of great importance in steam turbine work, because, as will be seen, the larger portion of the work is done by the steam at below atmospheric

pressure. The advantages of high vacua with steam turbines have been questioned by reciprocating engine builders, because of the increased quantities of cooling water that are required. This is dealt with in the chapter upon condensers. It may be mentioned, however, that Mr. Parsons claims that while there is a gain of 4 per cent. by the higher vacua obtained by his special apparatus, the cost of obtaining the vacua is only 1 per cent. of the total output.

## Turbines and Superheated Steam

The question of superheated steam has been fully dealt with in a previous part of the book, but more particularly with reference to reciprocating engines. The conditions ruling with steam turbines are quite different, as explained, to those ruling in reciprocating engines, and there should be no cylinder condensation, or anything corresponding to it. The containing cylinder of the turbine, when once warmed up by the entering steam, remains at a certain temperature, corresponding approximately to the temperature of the steam that is passing through it, and there should be no tendency for any portion of the steam or vapour to condense, by coming in contact with metals at a lower temperature. On the other hand, however, superheating of steam is a distinct advantage with steam turbines, but mainly for another reason. Even with steam turbines having all their parts, while working, at certain definite temperatures, it is better for the steam to enter dry, without the vapour it brings over from the boiler, as water loose in any steam system is always troublesome. In addition to that, however, superheated steam has a distinct advantage over saturated steam, in that it does not so readily part with its heat to the objects with which it comes in contact, as the blades of the turbine, the blades or buckets or diaphragms of the turbine, the containing cylinder, etc. According to Professor Siebel, the great authority on refrigeration, superheated steam has a less tendency to part with its heat to objects with which it comes in contact than saturated steam, in the proportion of one to forty; hence the use of superheated steam is a distinct advantage. In addition, there is very little trouble in arranging that the working parts of the steam turbine that are exposed to the high temperatures of superheated steam, shall be able to withstand those temperatures. Further, as no lubrication is necessary on the inside of the steam turbine case, such as is necessary in the reciprocating engine, to overcome the friction of the piston, the problem of a lubricant to stand the high temperatures which arises in connection with the lubricating of reciprocating cylinders in which superheated steam is employed, does not arise here.

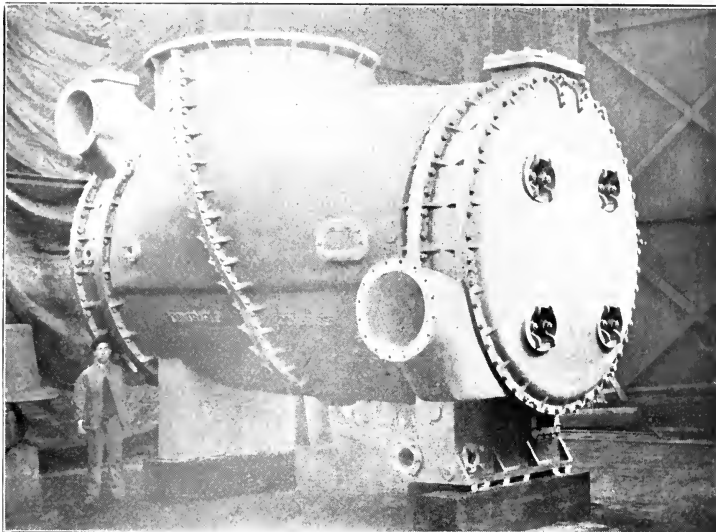

PLATE 23A.—Complete Contraflo Condenser.

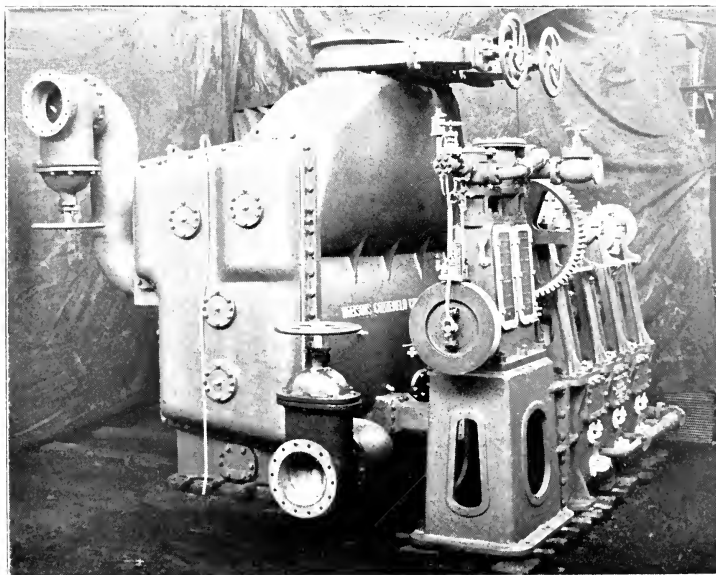

PLATE 23B.—Contraflo Condenser, with Air Pump. [To face p. 328.



Incidentally it may be mentioned, that it is claimed for steam turbines, that the exhaust steam is not contaminated with oil from the steam turbine, as it is from the cylinder of a reciprocating engine, and therefore can be used for feeding the boilers without the use of oil separators. It is stated even that the condensed water from the exhaust of steam turbines is used for certain purposes where distilled water is usually employed.\*

## CHAPTER VI

# CONDENSING PLANT

### The Condenser

THE condenser is the apparatus in which the steam which has done its work in the engine or the turbine is reconverted into water, and it is of very great importance in the economy of steam working. As was described in connection with the working of reciprocating steam engines, after the piston has completed its stroke, and when the steam enters on its other side to cause it to make its return stroke, the steam which remains in the cylinder from the previous stroke offers a certain resistance to the return of the piston, this being known as back pressure. Where the steam is allowed simply to discharge into the atmosphere, this back pressure will be that of the atmosphere, plus something in addition, the unused pressure of the steam itself, the back pressure gradually decreasing as the steam gets away. It can be seen, however, that even if the steam offers no back pressure to the piston, if the atmospheric pressure or a portion of it can be removed, the work the piston is enabled to do at each stroke is increased, and this is what is accomplished by condensing, the pressure in front of the piston being reduced in the latest modern plants to as low as 1 lb. per square inch.

With steam turbines, also, as explained, a largely increased duty is obtained by lowering the pressure at the exhaust, and allowing a larger range of the heat scale to be used.

To accomplish this the heat must be removed from the steam, and the steam reconverted to water. It will be remembered that the energy present in the steam is proportional to the heat that has been delivered to it, and that as the steam expands, doing work on the piston, or on the turbine, its temperature lowers, but even when the pressure is lowered to the very low figures mentioned above, the steam still contains a large quantity of heat in the latent form, and this must be removed before it can be reconverted to water.

The condenser is practically the reverse of the steam feed-water



heater. In the feed-water heater, it will be remembered, the heat of the steam is passed to the water through pipes, or directly, the temperature of the water being raised for the purpose of feeding the boiler. In the condenser the heat of the steam is again passed to the water, the temperature of which is raised, but it is for the purpose of condensing the steam and of depriving it of all its latent heat.

## Forms of Condenser

There are three forms of condenser, known respectively as the "Surface condenser," the "Jet condenser," and the "Ejector condenser."

### The Surface Condenser

There are two forms of surface condenser, the "enclosed" and the "evaporative." The enclosed surface condenser is practically the reverse of the enclosed feed-water heater, is constructed on very much the same lines, and is sometimes combined with it. There is an iron box, which may be of any convenient form, cylindrical or rectangular in section, the cylindrical form is a favourite; and there are tube plates at each end of the box, arranged to hold the ends of the tubes, which are of brass or gun-metal, according to the fancy of the maker, and the water with which it is likely to have to deal. The water enters at one end of the box, passes through the tubes, and out at the other end, the steam entering somewhere near the middle of the box on one side, passing over the outer surface of the tubes, and out at the other side, the steam being condensed to water in the process, and being drawn off by the air pump, as will be explained.

As with feed-water heaters, the reverse of this arrangement sometimes holds, the steam passing through the tubes, and the water passing on the outside, but the more frequent arrangement is for the water to pass through the tubes.

Two pumps are required to complete the surface condenser plant, in addition to the apparatus just described, a pump to circulate the cooling water through the tubes, and a pump to withdraw the condensed steam, and the air which comes over with the steam from the body of the apparatus. The latter is called the air pump, and it is of the utmost importance that it shall be thoroughly efficient. In fact, the extraction of the air from the space in which the steam is condensed forms one of the greatest difficulties in the matter of condensation, especially with very low pressures, or, as it is usually expressed, high vacua. Mr. Charles Parsons, who has worked at the

problem in connection with his steam turbine, has found that the presence of air in the condenser "blankets" the particles of steam, as he expresses it. That is to say, particles of air surround particles of steam, and prevent the transmission of heat from the steam to the cooling water, or cooling surface, and thereby increase the difficulty of the formation of the vacuum.

It will be remembered that at atmospheric pressure the steam has a pressure of 14.7 lbs. to the square inch, and by the action of an efficient condenser this pressure is gradually reduced to, in the cases of very efficient apparatus, as low as 1 lb. per square inch. As the pressure of the atmosphere balances the pressure of steam at atmospheric pressure, and as the pressure of the atmosphere is measured by the column of mercury 29.96 inches; as the pressure of steam is lowered, the column of mercury that it would balance is also lowered, and it is usual to express the work done in a condenser in terms of inches of vacuum. Thus, if the whole of the pressure of the steam can be removed, the vacuum would be expressed as 29.96 inches at sea level. On the other hand, the gradual lowering of the pressure is expressed by gradual increase of the vacuum in inches. Thus, it is usual to talk of 10 inches, 20 inches, 25 inches of vacuum, and so on, 29.96 inches being the highest possible under normal conditions at sea level, and 29 inches being practically the highest vacuum that has yet been obtained in ordinary work. Twenty-five inches was considered a high vacuum with reciprocating engines, it corresponding approximately to a lowering of the pressure of the steam by  $12\frac{1}{2}$  lbs. per square inch; but since the advent of the turbine, and the improvements that have been made in apparatus for producing good vacuum by Mr. Parsons and others,  $28\frac{1}{2}$  inches is very common.

In the production of a good vacuum the air pump plays a very important part indeed. The usual form of the air pump is described later. If the air pump does not pull out all the air as well as the condensed steam, the vacuum is not as perfect as it otherwise would be.

The circulating pump is also of considerable importance, though it is necessarily much simpler than the air pump. It will be understood that in order to extract the heat from the steam it is necessary to pass a certain quantity of water through the condenser, and that the quantity of water required will depend inversely upon its own temperature and directly upon the inches of vacuum required, the quantity increasing very rapidly with high vacua, as explained more fully on pages 351, *et seq.* It will be understood that the cooling water can only be raised to a certain temperature in its passage through the condenser. In practice,  $150^{\circ}$  F. is usually the limit, though on occasion cooling water is sometimes raised to as much as

175° F.; but it is not economical to do so. This being so, and as every gallon of water absorbs 10 heat units for every degree F. of increase of temperature, it will be evident that the lower the temperature at which the water enters, the smaller will be the total quantity required. Thus, with the water at 50° F., each gallon passed through the condenser should absorb 1000 heat units, while if only water of 100° is available, each gallon will only absorb 500 units, and double the quantity must be employed. Hence will be seen the reason for

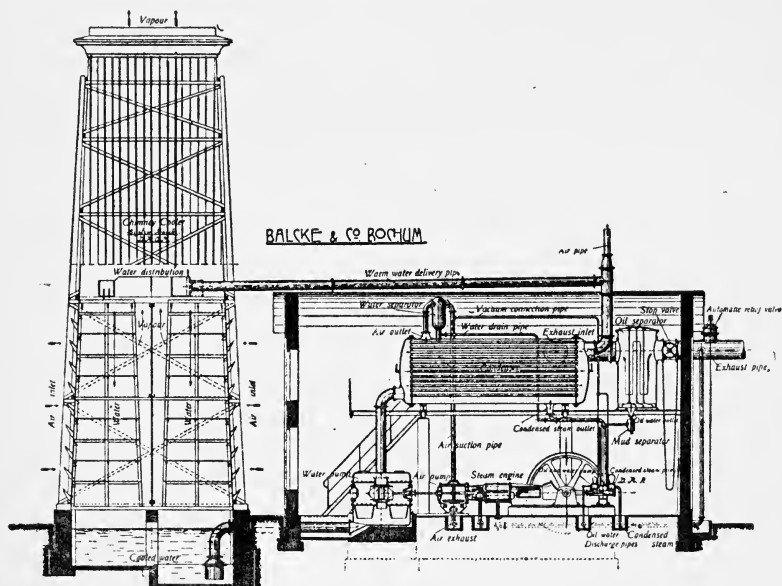

FIG. 158.—Sectional drawing of Surface Condenser and Cooling Tower, with Accessories.

employing cooling towers and other apparatus for the circulating water.

As explained in dealing with the heating of feed water, the cooling water from the condenser is frequently used for the boiler feed, since it is not impregnated with oil, etc., but this can only be where cooling water is plentiful, as where the boiler is fixed close to a river or canal, from which unlimited water may be taken. In a great many instances, unfortunately, water is very expensive, so expensive in some cases that the saving in coal from the lowered pressure in front of the piston is more than balanced by the cost of the water and other expenses for cooling. In these cases, where condensation is carried out, some form of cooling appliance is employed, the cooling water being used over and over again. Fig. 158 is a sectional

drawing of a surface condenser with a cooling tower. The quantities of cooling water employed with the ordinary condensers are given further on.

### The Evaporative Surface Condenser

In the evaporative condenser the property possessed by air of absorbing the vapour of water is made use of to reduce the quantity of the cooling water. In this apparatus the steam to be condensed passes through a grid of pipes, as shown in Fig. 159, which is one of Ledward's evaporative condensers, and a stream of water is made to

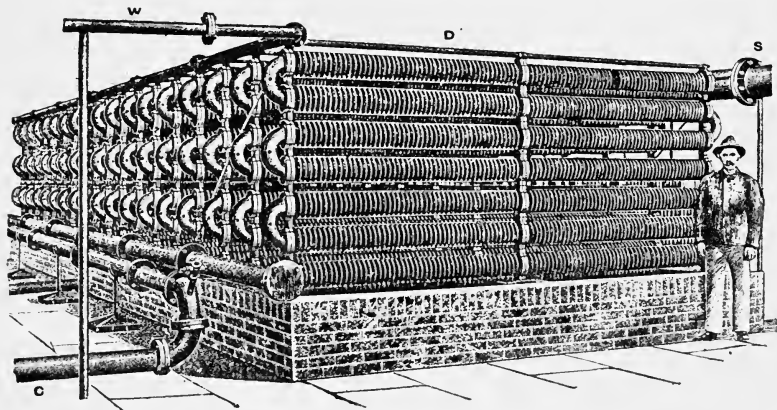

FIG. 159.—Ledward's Evaporative Surface Condenser. **S** is the Exhaust Steam Pipe; **W** the Cooling-water Pipe; **C** the Condensed Steam Pipe.

trickle down over the outside surface of the pipes, the steam being condensed on the inside, and being withdrawn by the air pump, as in the enclosed surface condenser. The usual arrangement is: A pipe having perforations on its under side is fixed above each of the rows of pipe forming the grid, and a trough is fixed below the whole of the grids, so as to catch all the water that is not evaporated, after it has passed over the pipes. The water is forced out of the perforations in the upper pipe in the form of very fine jets, and it is made to trickle over the outside of the condenser pipes in a very thin stream, so that it may be exposed to the full action of the atmosphere. The cooling action is twofold. The water absorbs a certain quantity of heat from the pipes over which it passes in raising its own temperature, but a very much larger quantity of heat is extracted from the water, and through it from the pipes, and thence from the steam by the evaporation of a small quantity of the cooling water. Each pound

of water in forming vapour will absorb in the neighbourhood of 900 units, and this is taken almost entirely from the pipes and the condensed steam, hence the quantity of water required is very much less than with the enclosed form. The cooling effect of the evaporative condenser depends upon the temperature at which the water is first delivered to the pipes, also upon the temperature and degree of humidity of the atmosphere, and upon the force of the wind. It is usual to fix evaporative condensers in positions where the pipes and the water will feel the force of any wind that may be blowing, but so that the water will not be blown away to any extent. The cooling effect of the water itself, by reason of its rise of temperature, forms only a small portion of the total cooling. The cooling effect of the evaporation depends upon the humidity of the atmosphere, as explained in Chapter I., upon the tension of the vapour issuing from the water, and upon that present in the atmosphere. The ability of the atmosphere to absorb moisture increases with the temperature, as already explained in Chapter I.; but, on the other hand, the atmosphere is often so full of moisture on the days that we call muggy, that it is unable to absorb any more. In those cases there may be even deposit from the atmosphere in the cooling water. The action of the wind has a most important bearing upon the quantity of water required, because, it will be understood, each cubic foot of air, at a certain temperature and a certain humidity, is able to absorb a certain quantity of vapour, and therefore the rapid passage of an air current across the grid of pipes over which the water is passing increases the cooling effect due to the atmosphere alone. The author has been told of cases of evaporative condensers exposed to cold winds where the cooling water was colder after it had passed over the condenser than before it was delivered to it.

The quantity of water used with evaporative condensers varies from fifteen times the weight of steam condensed with dry, warm air, such as would rule in parts of America and Canada during the summer, to forty times with very muggy air. A certain quantity of the cooling water is lost by evaporation, the amount varying with the conditions.

### Fraser's Evaporative Condenser

This is an apparatus in which the principle of cooling by evaporation is carried out in a novel manner. The apparatus is enclosed in place of being open to the atmosphere, as in the case of the evaporative condensers described above. The pipes through which the steam passes are fixed inside a case, arranged in a stack in the usual way. The cooling water is pumped to the top by a centrifugal pump, and

is discharged over the top of the condenser tubes by spraying nozzles 1 inch in diameter, the water falling over the outside of the tubes as in other forms of evaporative condenser; but in place of depending upon atmospheric air for the evaporation, fans are fixed at the base of the apparatus, and these drive a current of air up through the tubes, meeting the spray of water descending over them, and causing evaporation in the same manner as in the open evaporating condenser. It is claimed that this arrangement is an improvement on the open evaporative condenser, as the tubes are not exposed to the dust, etc., that is in the atmosphere, and that is often deposited upon them, leading to the formation of a scale that resists the passage of heat through them, in the same manner as has been explained in connection with boiler tubes. The tubes are of brass,  $\frac{3}{4}$ -inch external diameter, similar to those employed in marine condensers, fixed in tube plates by brass ferrules and tape packing; and it is claimed that the expansion and contraction of the tubes causes any scale that is formed upon them owing to hardness of water, to crack and be thrown off, leaving the tubes clean. It is also claimed that, being enclosed, this condenser is not affected by the direct rays of the sun, nor by winds, and is comparatively independent of variable atmospheric conditions. It is also claimed that the power required to drive the fans is very small, as very little obstruction is caused by the water falling over the tubes, the water-gauge being, it is stated, under  $2\frac{1}{2}$  tenths of an inch; and, further, that the condenser does not make itself a nuisance in the neighbourhood by throwing out spray.

In connection with this condenser a double-acting air pump, specially designed, is employed.

## The Wheeler Surface Condenser

In the Wheeler condenser, a sectional drawing of which is shown in Fig. 160, and which is made either in circular or rectangular form—preferably rectangular,—the condenser vessel, as seen, is divided into two portions, the water passing through the two in succession. The steam, as will be seen, enters at the top, the condensed steam leaving at the bottom, and the cooling water enters by the inlet at the bottom on the right, passes through the lower bank of tubes, then through the upper bank of tubes, and out at the water outlet at the top on the right. It will be noticed that the principle upon which all apparatus in which heat passes from one fluid to another are constructed, is observed in this, the hottest steam passing over the tubes in which the hottest water is circulating, and the coolest steam or the condensed water meeting the coldest water as it enters.

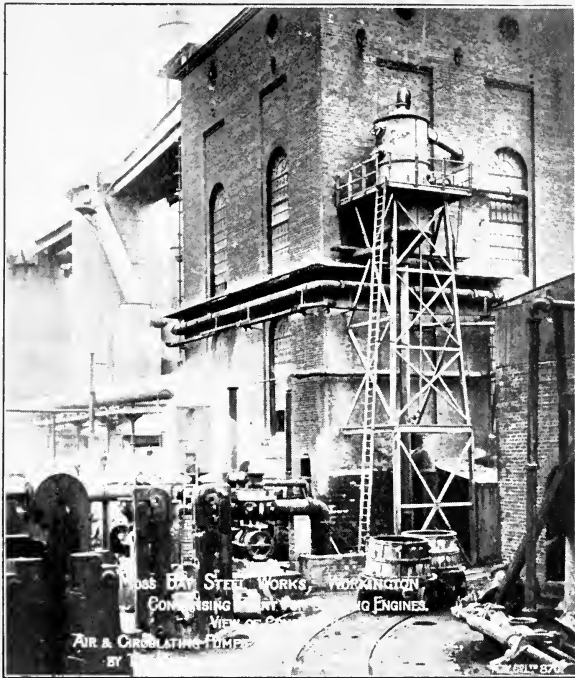

PLATE 24A.—Condensing Plant for a Pair of large Blowing Engines at a Steel Works. The Condenser is seen on the Wall of the Engine-house.

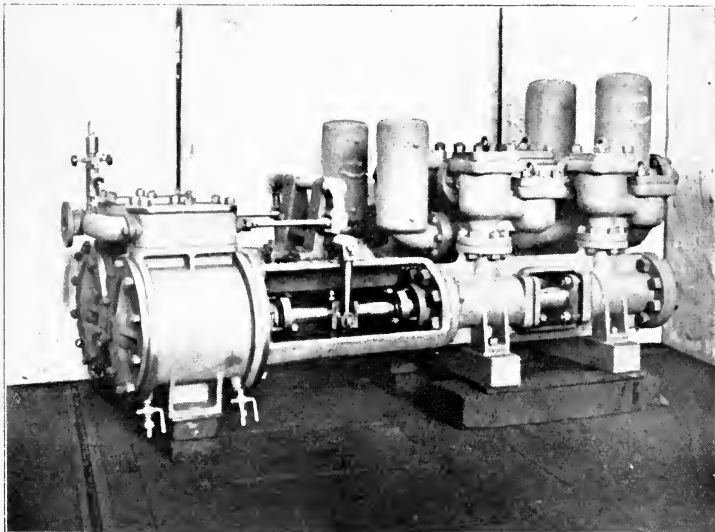

PLATE 24B.—Tangey Duplex Double-acting Steam Pump.

[To face p. 336.]





In the Wheeler condenser also, the tubes are sometimes held between tube plates, and sometimes are arranged on the double-tube system, the tubes in that case only being held at one end, and being free to expand and contract.

In one form of the apparatus the condenser, the air pump, and the circulating water pump are mounted together upon one bed plate, the inlet tube for the water and the outlet tube for the steam forming practically the supports of the condenser chamber. A single steam cylinder drives both the water and the air pump pistons.

In another apparatus the Wheeler Company have combined the feed-water heater with the condenser. The vessel forming the combined apparatus is divided into two, which are constructed practically alike, with tubes held between tube plates, the feed water for the boiler circulating through the tubes in the upper portion, while the cooling water for the

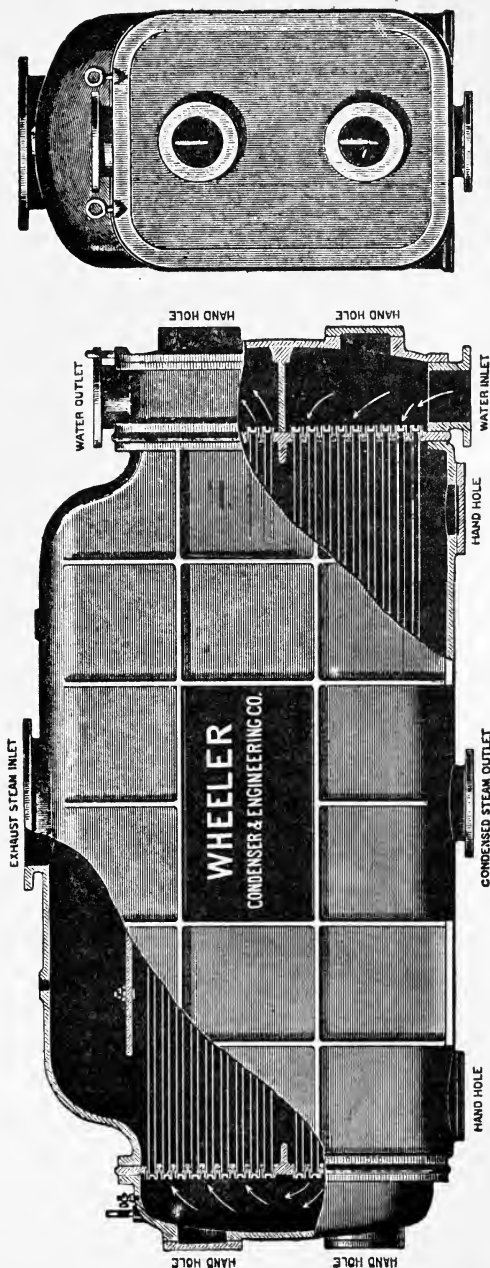

Fig. 160.—Wheeler Surface Condenser. The Tubes are in two portions, the Water passing in the lower half from right to left, and in the top half from left to right.

condenser itself circulates in the lower portion, passing through the banks of tubes in succession. The exhaust steam enters at the top, and is guided by baffles to the right and left of the entry, then passing over the feed-water tubes and the condenser tubes in succession. Where some of the circulating water is employed as feed water, it will be seen that the arrangement can be carried out very conveniently.

## Open Tank Surface Condensers

The Klein Engineering Company, the Balcke Company, and others, construct a modified surface condenser, in which the steam circulates inside the tubes in place of outside, the tubes being built into stacks, and placed in open brickwork tanks, the cooling water being caused to pass slowly through the tanks and around the tubes by the circulating pump in the usual way.

A modification of this is made by the Klein Co. for laying in the beds of streams. A brickwork tank is built in the bed of the stream, and the water is allowed to circulate through the tank under the force of the stream.

## The Contraflo Condenser

This is a form of surface condenser introduced within the last few years by Messrs. Richardson, Westgarth & Co., in which

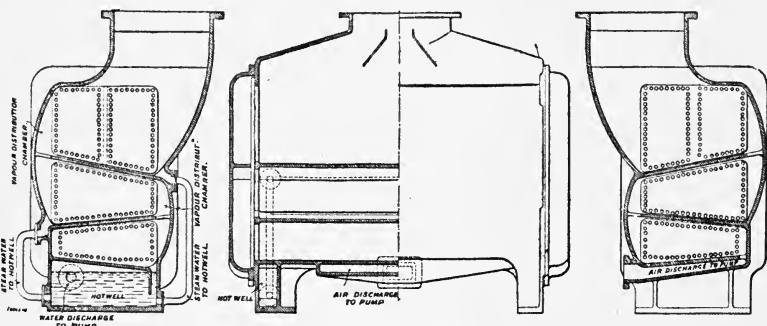

FIG. 161.—Sectional drawings of Contraflo Condenser, showing the divisions of the Condenser, the Hot Well, etc.

certain novel features are introduced that are claimed to increase the efficiency of the apparatus. The complete apparatus is shown in Plates 23A and 23B, and sections of it in Fig. 161. From the sectional

drawings it will be seen that it is practically three separate condensers, each fitted with pipes for the water to circulate in, on the lines of the ordinary surface condenser, but the three condensers are arranged in series, that is to say, the steam passes through the three, one after the other, the condensed water finally finding its way to the hot well shown at the bottom. In addition, each of the separate condensing chambers is drained of its water by separate pipes communicating with the hot well. The steam enters by the steam pipe at the top, passes over and between the condensing pipes in the upper chamber, then it passes by the vapour-distribution chamber, as it is termed, shown on the left in the transverse vertical section on the left of Fig. 161, into the second condensing chamber. It passes over the pipes in the second condensing chamber, and thence by way of the vapour-distribution chamber on the right, to the third and lowest condensing chamber. The vapour-distribution chambers, as will be seen, are really communications between the different condensing chambers. The idea in the mind of the inventor of the Contraflo condenser is, that the major portion of the condensation takes place in the neighbourhood of the upper condensing pipes, where the first cooling takes place, and that if the condensed water formed there can be drained away, there is less chance of any portion of it being re-evaporated. One of the difficulties in connection with condensers is, any water that is formed by condensation when the steam enters a condenser may be re-evaporated into steam, and have to be recondensed if the conditions are favourable. It was explained in the first chapter that the formation of steam depends upon the heat present, and upon the pressure to which the surface of the water from which steam is to be made is exposed. Lowering the pressure allows steam to be formed at a lower temperature than with higher pressure, and as it is a necessity of the case that the pressure in the condenser shall be continually lowered by the air pump, it follows that the conditions favourable for the reformation of steam may occur during the later portion of the passage of the condensed steam through the condenser.

The usual counter current arrangement is adopted in the Contraflo condenser. That is to say, the cooling water enters the pipes of the lowest portion of the condenser, and is forced upwards, passing to and fro in successive lengths of pipes, finally issuing at the top; the steam, passing downwards from the top, and issuing into the hot well. Thus, the hottest water, that which has already done work in cooling the steam and water below it, meets the hottest steam, and the coldest steam or condensed water meets the coldest cooling water.

## Jet Condensers

The jet condenser is practically the reverse of the open feed-water heater, but the apparatus is designed primarily for condensing the steam, and not for heating the water, though the water is necessarily heated in the process. The jet condenser consists of a vessel of various forms, into which the steam is brought, and also into which the cooling water is brought in the form of a spray. The steam meeting the water, gives up its heat to the water, is condensed, and the two are pumped out together by the air pump, just as in the surface condenser.

There are two methods of arranging the jet condenser, known as the parallel-current and counter-current apparatus. In the parallel-current apparatus the steam and water enter more or less opposite each other, and flow in a parallel direction through the condenser vessel, the two mixing, and the water being condensed on the way. In the counter-current condenser, the steam enters from one side, and the water from the other, and the two flowing in opposite directions, mix as before. The vessel into which the steam and water enter has various forms. Usually with the counter-current design, it is fixed in a horizontal position, and consists of a cylinder, the steam entering from one end, the water from the other, and the condensed water being pumped out from the end at which the water enters. In one form of the counter-current jet condenser, made by Messrs. Balcke, the main condensing vessel consists of a horizontal cylinder, the steam entering it by a steam pipe on the left, and the water entering through a dome above the right-hand portion of the condenser. The object of the dome is to separate the air that comes in with the steam from the water, and the operation of the condenser is as follows: The steam entering the main condensing vessel meets the large body of water below, and nearly the whole of it is condensed. A portion, however, passes onward and enters the dome, where it meets the cold spray produced in the dome, and is condensed, the air and incondensable gases passing upwards and being pumped out by the air pump connected to a pipe at the top. The condensed water is pumped out through a pipe at the bottom by a pump, and is delivered to the air cooler, the cooling water for the condenser being taken from a tank on the one side of the cooling tower, into which the water from the bottom of the tower overflows.

It is claimed that with the combined arrangement of jet condenser and cooling tower, the water lost by evaporation in the process of cooling is made up by that condensed from the exhaust steam.

Two pumps are required for the jet condenser, the air pump which will be of a similar form to that employed with the surface

condenser, but a little larger, as it has to deal with the cooling water as well as with the water formed from condensed steam, and a pump to deliver the cooling water itself, which must be arranged in the form of a spray.

The jet condenser is more efficient than the surface condenser, so far as the quantity of water required for cooling is concerned, but it is not as well liked as the surface condenser.

### The Mirrlees-Watson Jet Condenser

In this apparatus a new departure has been struck. The condenser vessel contains a number of trays, fixed one above the other, and the water enters the condenser at the top, and is broken up by falling over the trays, very much after the manner of the arrangements made in some cooling towers. The steam enters at the bottom, and is obliged to pass through the trays. The air is drawn out from the upper part of the condenser, and is therefore at its minimum volume, this applying to other forms of jet condenser where this arrangement rules, while the condensed water is pumped out at the bottom.

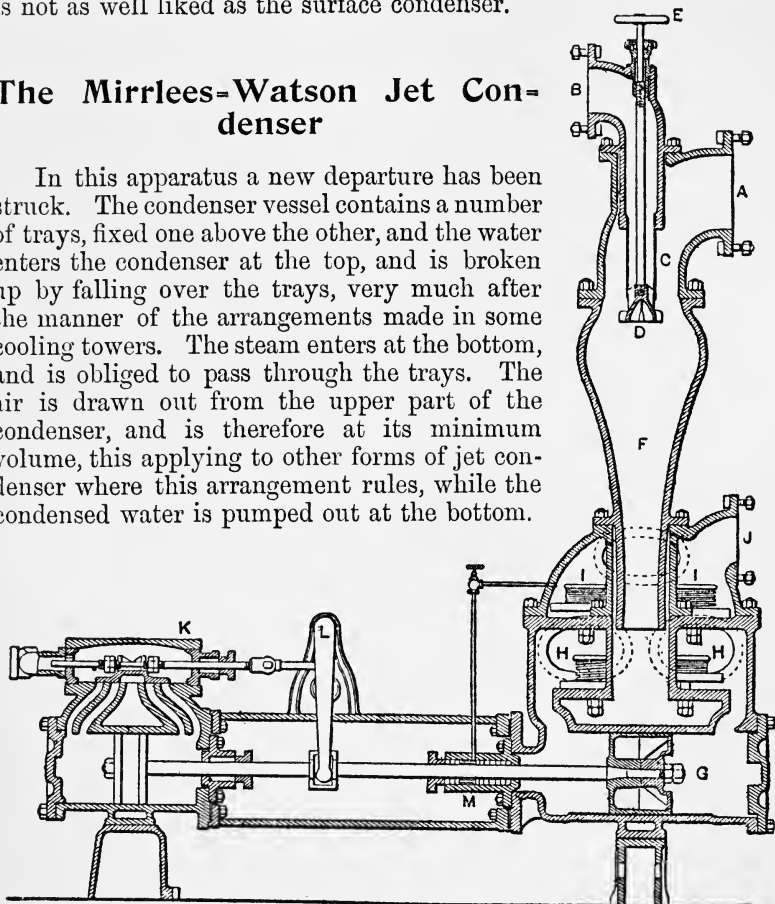

FIG. 162.—Section of Worthington Jet Condenser and Pump.

### The Worthington Jet Condenser

The Worthington jet condenser, with its pump, is shown in section in Fig. 162, and fully in Fig. 163. It will be seen that the condensing

vessel is cone-shaped, the exhaust steam entering by the pipe A on the right, and the cooling water by the pipe B on the left. The entrance B must not be more than 20 feet above the surface of the water supply

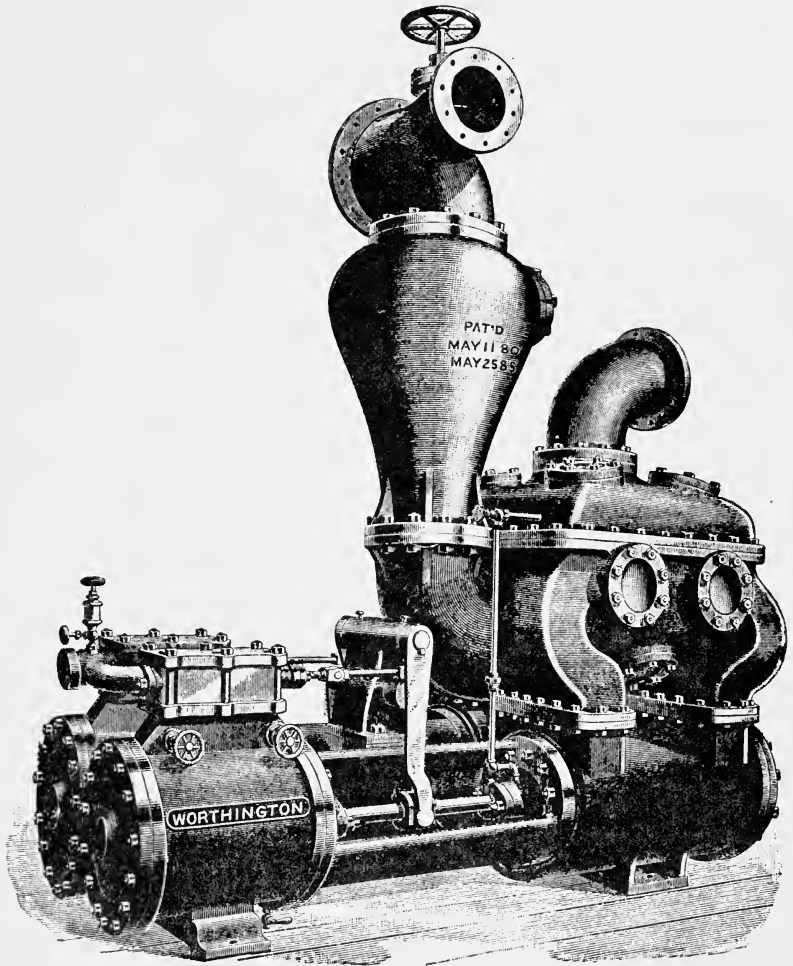

FIG. 163.—Worthington Jet Condenser for 1500 H.P., with Pump.

when used with steam engines. The water jet is broken up into a fine spray before it enters the condensing vessel by means of the spray pipe C, into which the pipe B enters, and the spraying cone D. The pump shown is of the piston type, driven by the steam cylinder

K, and constructed generally on the lines of the Worthington pumps. The Worthington jet condenser pump is sometimes worked by a compound or triple-expansion steam cylinder, on the lines of the Worthington pumping engines of those types, the piston rod of the high-pressure cylinder being connected to the pump rod, which also carries a cross head, through which connection is made to the low-pressure piston, the low-pressure and intermediate-pressure pistons being connected by one rod.

The pump described above is the air pump of the condenser, and it is claimed that it performs the office of air pump quite as well as those specially designed for the purpose, the pump being specially arranged to deal with the air and water. The water cylinders are lined with composition, and the glands and the stuffing boxes and the valve seats, etc., are of the same material.

The velocity with which the steam enters the cone F of the condenser, it is claimed, carries with it the water and all the air or uncondensable vapour that has come over with it, the air and water being fully dealt with by the piston pump, and being discharged through the valves shown at H and I, and the pipe J, in Fig. 162.

## The Ejector Condenser

In the ejector condenser, forms of which are shown in Figs. 164 and 165, the action is somewhat similar to that of the injector, but reversed. In the ejector condenser a stream of water is kept continually pouring through a vessel, as shown, into which the exhaust steam is delivered. The passage of the stream of water

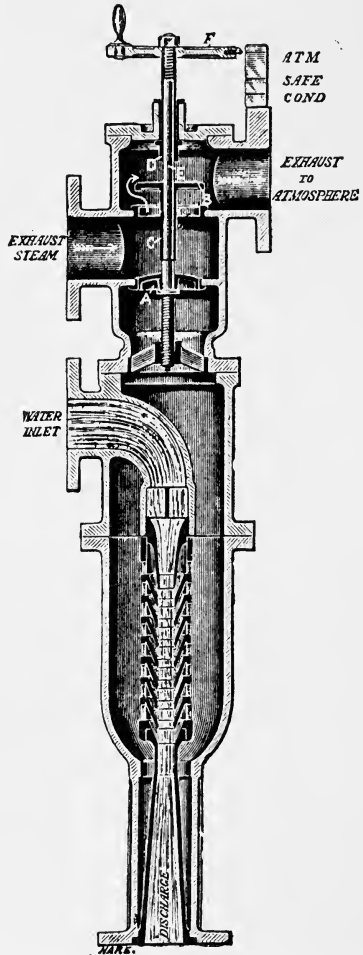

FIG. 164.—Section of Ledward Ejector Condenser, with three-way automatic Valve, providing for exhausting to the atmosphere if required.

through the apparatus draws the exhaust steam after it, in the well-known injector manner, and the steam meeting the water, is immediately condensed and passes off with it. The ejector condenser has the great advantage of being exceedingly simple. Only one

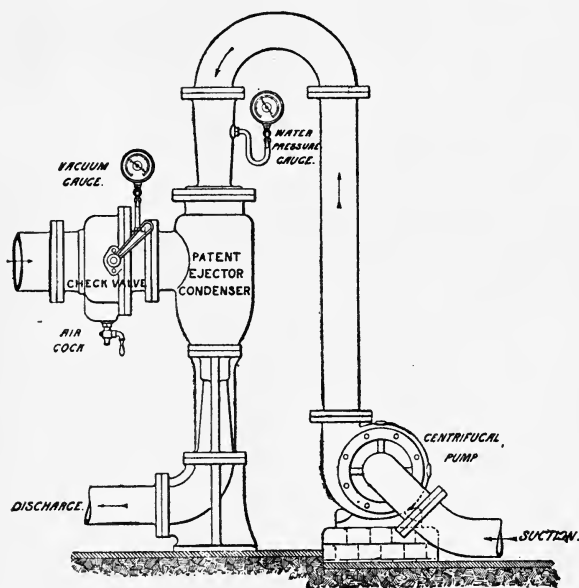

FIG. 165.—Diagram of arrangement of Steam and Water Pipes, with Ledward's Ejector Condenser.

pump is required, that for providing the stream of cooling water, which is allowed to run away, or is used over again, as may be arranged.

## The Barometric Condenser

The barometric condenser is practically a modification of the ejector condenser. The arrangement is shown in Fig. 166, and the condenser vessel in section in Fig. 167. It takes its name from the fact that a column of water of the height equivalent to the mercurial barometer—that is, giving the same pressure, 14.7 lbs. to the square inch, or as the ordinary 29.96 inches of the mercurial barometer—is employed to do the work that is performed in other types of condenser by the air pump. The condenser itself is fixed at the top of a pipe about 30 feet high, and the exhaust steam is led



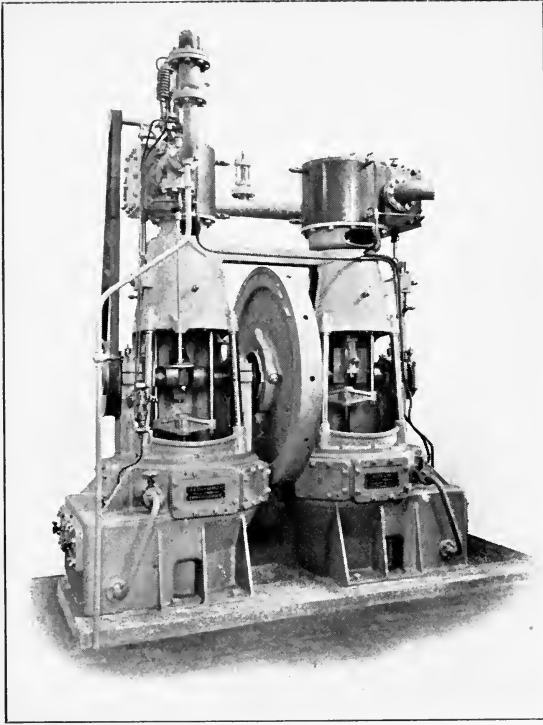

PLATE 25A.—A Pair of Vertical Double-acting Pumps for circulating the Condensing Water, by the Mirrlees Watson Co.



PLATE 25B.—  
Hall's Vertical  
Duplex  
Steam Pump.

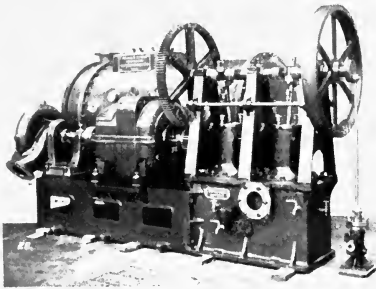

PLATE 25C.— Surface Condenser with Two-  
cylinder Edwards' Air Pump, Centri-  
fugal Circulating Pump, both driven by  
one Electric Motor, and all on one bed-  
plate.



PLATE 25D.—  
Hall's Single  
Vertical Steam  
Pump.  
[To face p. 344.]



up another pipe, standing by the side of the condenser pipe, to a point a few feet above the condenser. The top of the exhaust-steam pipe is provided with a relief valve, and usually an exhaust

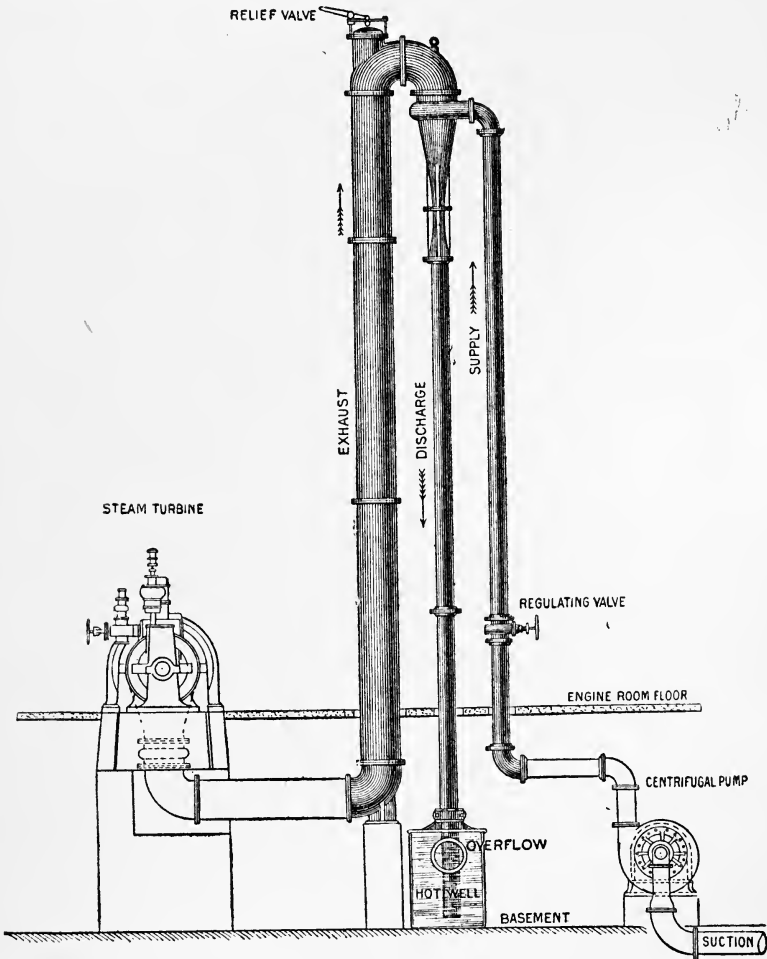

FIG. 166.—Arrangement of Pipes, Pumps, etc., of Bulkley Barometric Condenser, connected to a Steam Turbine.

head, on something the lines that have been described with other exhaust heads. The bottom of the condenser pipe is carried nearly to the bottom of a vessel called the hot well, into which the condensed steam and the condensing water is delivered, and from which

it overflows into any receptacle that may be provided for it. The hot well is usually covered, and it is required to be waterproof, that is to say, no other water must come into it, except that delivered from the condenser. The cooling water may be delivered to the condenser from a tank at a height that will allow the water to run into the condenser by gravity, or, where that is not available, it may

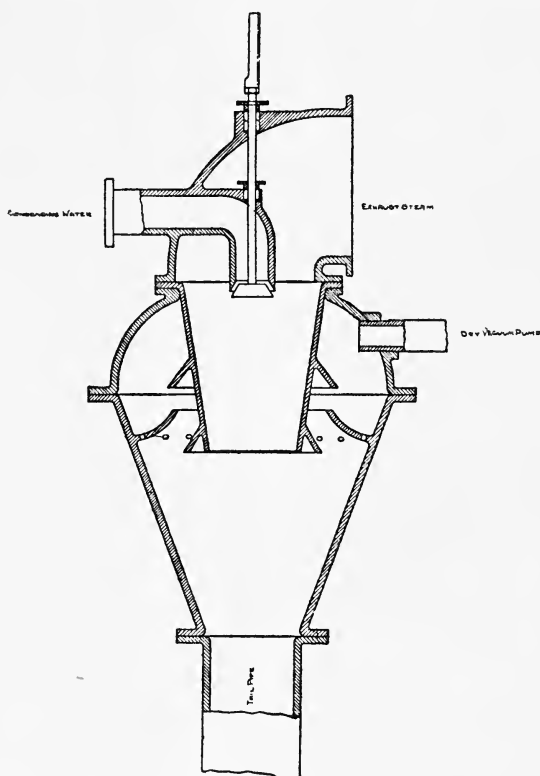

FIG. 167.—Sectional Diagram of the Barometric Tube Condenser, made by Williamson Bros., of Philadelphia.

be pumped up by any convenient pump, centrifugal or otherwise, driven by any convenient source of power. The pump, though it has to deliver the water to the condenser at about 30 feet above the hot well, has not really to lift the water that height, the partial vacuum in the condenser pipe assisting the lift in the pump delivery pipe to the extent usually of about 22 feet, so that the lift of the pump is only about 7 or 8 feet. The water is carried into the condenser

in the form of a hollow cylindrical sheet or jet, and the steam is delivered in the middle of the water jet by a cone, in the well-known injector manner. The passage of the water down the tube draws the steam up the exhaust and down the barometric condenser tube, the steam combining with the water, and the velocity acquired by the water in falling being sufficient to draw down the air which comes over with the steam, as well as the exhaust steam itself. It will be seen that the great advantage obtained by the use of the barometric condenser is the extinction of the air pump.

In some forms of the apparatus an air pump is employed as well.

### Parsons Vacuum Augmenter

The importance of a high vacuum for steam turbines has been mentioned in another portion of the book. The difficulty of obtaining

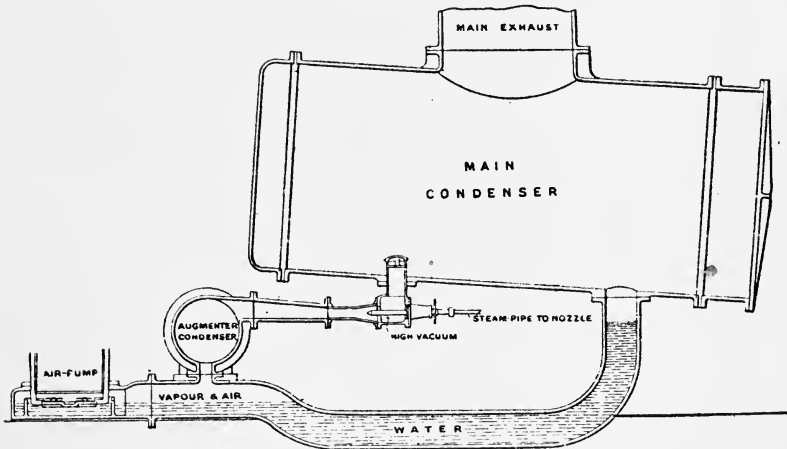

FIG. 168.—Section of Parsons Vacuum Augmenter.

high vacua is dealt with later. It requires a considerably increased quantity of cooling water, a larger surface in the condenser, in proportion to the quantity of steam to be condensed, and a higher velocity of the cooling water. In addition, a larger air pump is also required, as when high vacua are reached, the air is more important than at any part of the condensing cycle. With all these arrangements, however, it was till recently only possible to obtain a vacuum of from  $27\frac{1}{2}$  to 28 inches of mercury, and to meet the case, Mr. Parsons has worked out an apparatus, shown in section in Fig. 168, which he has called a "vacuum augmenter," by which he is enabled

to obtain the vacuum named,  $27\frac{1}{2}$  to 28 inches, without any other alteration to the plant, or higher vacua with the increase of circulating water, etc., mentioned. The apparatus is an ingenious application of the injector principle, applied to draw off the air and vapour from the lower portion of the condenser into an auxiliary condenser, marked in the drawing, "augmenter condenser." The auxiliary condenser has from 2 to 3 per cent. of the cooling surface of the main condenser, and its office is to cool the air, and partially condense the vapour it draws off before it enters the air pump. It will be remembered that the lower the temperature of any quantity of air that has to be dealt with, the smaller its volume, and therefore the work the air pump has to do is lessened. The main pipe leading from the condenser to the air pump, is shown leaving the right of the condenser in the drawing, and, as will be seen, the auxiliary condenser delivers its air and water to this pipe just before it enters the air pump. The consumption of steam in the steam jet is stated not to exceed  $1\frac{1}{2}$  per cent. of the total steam dealt with at normal load in the main condenser.

## Central Condensing Stations

The idea of distributing power by means of electricity from one generating station has led to the idea of condensing the whole of the steam from a group of engines within a certain range by one condensing plant, the same reasoning which makes the central generating plant economical also making the central condensing plant economical, providing that the arrangements are properly carried out. A central generating plant is rendered economical from the fact that a smaller plant can be employed to furnish power for a given number of machines or works than would be necessary in the aggregate if each works or each machine was provided with its own plant. In any works, or in any group of works, there are always some machines which are temporarily idle from various causes. If we take a fitting shop, for instance, containing lathes, planing machines, drilling machines, and so on, it is very rarely that the work any one machine is doing commences and ends at the same time as that of all the other machines. The work is necessarily variable, the men attending the machines are variable, and the times of stopping and starting machines to put in new work, or to attend to the machine for one of the numerous causes from which it requires it, necessarily varies, and hence it follows that approximately not more than 40 per cent. of the machines are working at any one time. If, again, we take a group of engines, say, at a colliery, a steel works, or some works of the kind, consisting of winding engines, hauling engines, pumps,

rail-mill engines, blowing engines, and so on, it will be found that some of the engines are always stopped. Thus, winding takes place at certain intervals, the cage requiring to be unloaded and reloaded while the engine stops; hauling, though it is less liable to stop on the endless rope system than on some others, is still liable to it; rail mills can only run when the billets are ready for them, and so on, and it follows that as these engines are working more or less intermittently, the steam which they exhaust is also delivered intermittently, and the total quantity of steam to be condensed is considerably less, and can be dealt with by a condensing plant of smaller capacity than would be necessary if each engine had its own condenser. There is the objection, of course, that anything which upsets the working of the central condensing plant, upsets the working of the engine; but this is not really serious, as it should always be arranged that the exhaust can be turned on to the atmosphere temporarily and quickly in case of accident. A central condensing plant has been fixed by the Mirrlees Watson Company for the Scottish Co-operative Society, and arranged for condensing the steam from three sets of engines, each of 530 H.P., and one of 330 H.P., all of the high-speed type, the steam being supplied by four water-tube boilers working at 150 lbs. pressure per square inch. The plant is of the barometric jet condenser type, the steam being delivered from the exhaust of all the engines to one large pipe, which is carried vertically up to the condenser. The water pumps and the air pumps stand side by side at the bottom, and the cooling tower at the top. The injection water is pumped to the condenser, and passes from the condenser down to the hot well in the usual way, the air being pumped out of the top of the condenser by the air pump, and being cooled and separated from the water on its way by passing through an air cooler and water separator. The condenser is of the type described on p. 341, fitted with trays for breaking up the water.

Fig. 169 shows a central condensing plant fixed by the Klein Engineering Co., in which open-surface condensers are employed with cooling towers.

## The Quantity of Cooling Water Required for Condensing

The quantity of cooling water required for condensing steam varies with the form of condenser, and with the initial temperature of the cooling water, the velocity at which the water is passed through the condenser, and the cooling surface exposed in the

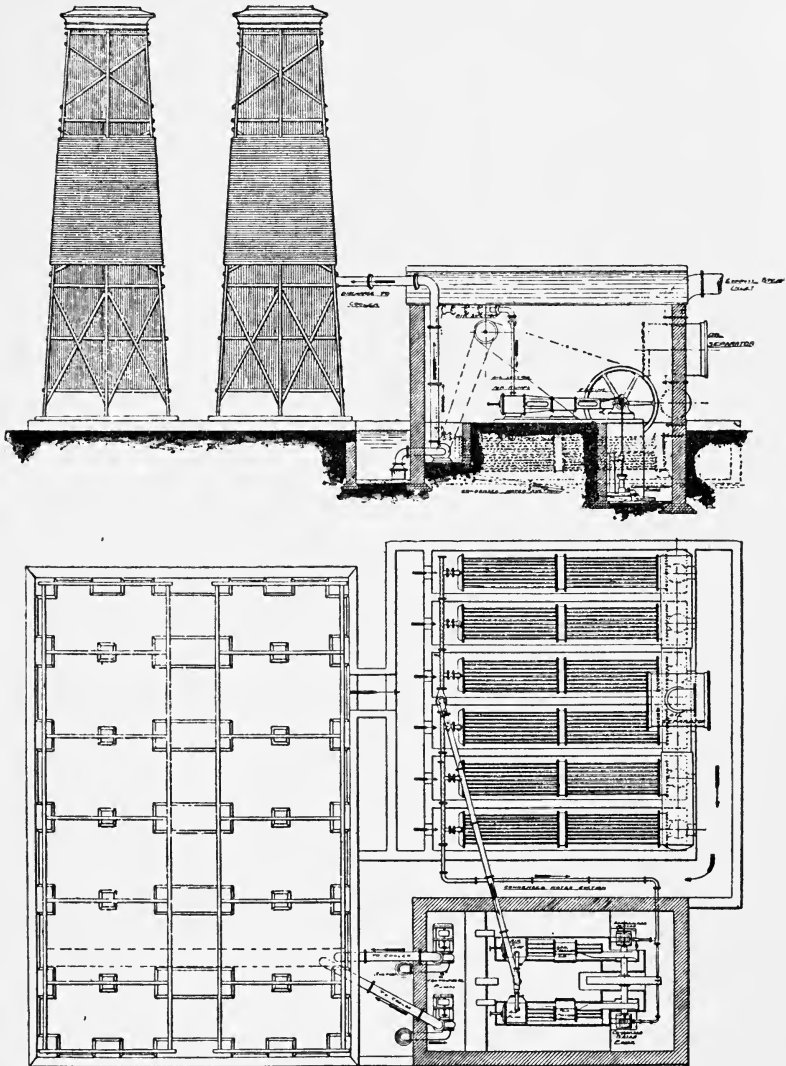

FIG. 169.—Plan and Vertical Section of Central Condensing Plant, with Cooling Tower, made by the Klein Engineering Co. The Condensers are of the open surface type described on page 339.



condenser. It has been explained in Chapter I. that water will absorb heat from any heated surface, directly in proportion to the difference of temperature between the water and the surface it is in contact with, and therefore it will easily be understood that the lower the initial temperature of the water, the larger capacity it has for absorbing heat under all conditions. It will be understood also that in the surface condenser, the tubes through which the water passes are virtually heating surfaces for the water, just as the tubes in a water-tube boiler are. It will be understood, also, that the quantity of heat that any body of water, say a gallon, can abstract from the steam it is to cool, will depend directly upon the difference between the initial and final temperatures, and here comes in a difference between the injector and surface condensers. With the surface condenser the temperature of the cooling water cannot possibly leave the condenser at the same temperature as the steam. In practice there is a difference of from 15° to 20° F. between the two, while with the jet condenser the water is raised to the temperature of the steam itself, providing the water is in the proper proportion. Hence it is claimed that the jet condenser has an advantage over the surface condenser under any given conditions of about fifteen times the weight of steam. That is to say, with surface condensers the cooling water required is in the neighbourhood of forty times the weight of steam it is to condense, whilst with the jet condenser it need only be twenty-five times. With either form of condenser, however, and knowing the initial temperature of the cooling water, and the temperature to which it can be raised in its passage through the condenser, the calculation for the quantity of water per pound of steam is a very simple one, and is found from the following formula—

$$Q = \frac{S \times L}{T - t}$$

where Q is the number of pounds of water required, S is the number of pounds of steam to be condensed, L is the latent heat of steam at the condenser pressure, T being the initial and the final temperature of the cooling water; or if the quantity is required in gallons, the formula becomes—

$$Q = \frac{S \times L \times 10}{T - t}$$

When high vacua are to be obtained, the conditions are more severe than with low vacua. Above a vacuum of 26 inches the latent heat of the steam is increased, as will be remembered, and in addition, the volume of the steam is also very largely increased. Thus, approximately, the steam doubles its volume between vacuum of 26 and 28

inches, and again more than doubles it between 28 and 29 inches. The result of this is, as explained in connection with the Parsons vacuum augmenter, the quantity of cooling water is considerably increased. Mr. Parsons found that, with a condenser having an allowance of 1 square foot of surface per indicated H.P., a vacuum of 26 to 27 inches could be obtained by the circulation of a quantity of cooling water 30 times that of the steam to be cooled, the initial temperature of the cooling water being 70° F. For higher vacua he found that it was necessary to increase the condenser surface to 1½ square feet per indicated H.P., and to increase the velocity of the cooling water from the tubes, to from 4 to 7 feet per second. He also found that it was necessary to construct the condenser with the tubes spaced wider apart than is usual, so that the steam could have an easy flow among them, and to submerge the lower tubes in the condensed water, before the water was carried off by the air pump, this being done by providing a weir at the bottom of the condenser, which held up the condensed water, so as to cover two or three rows of tubes. It should be mentioned that this arrangement has been frequently adopted by other makers.

It should be mentioned also that the velocity at which the cooling water passes through a surface condenser has an important bearing upon its cooling effect, up to a certain critical figure. Apparently there is a certain minimum time for the cooling water to be in contact with the condenser tubes, in order that it may absorb the fullest amount of heat from them, and this forms the critical speed. A speed which does not allow of this minimum time in contact, should not give as high a cooling effect with any given surface, and with any given difference of temperature between the inlet and outlet of the cooling water, as should be obtained if the proper minimum time is allowed. This would be the case of too high a velocity. On the other hand, up to the critical velocity, the water does no good by remaining in contact with the heating surface longer than is necessary for it to abstract the maximum amount of heat.

### **Mr. Richard Allen's Experiments on Condensers**

Mr. Richard Allen, of the firm of W. H. Allen & Son, who have made a speciality of surface-condensing plants for some time, carried out some experiments upon surface condensers a couple of years ago, which are exceedingly interesting, and which throw a very important light upon the question of the quantity of cooling water required under different conditions, and with different vacua. The curves shown in Figs. 170 to 177 which are taken from the paper contributed by Mr. Allen to the Institution of Civil Engineers, and the extracts from his paper, are reproduced with the permission of the Institution and

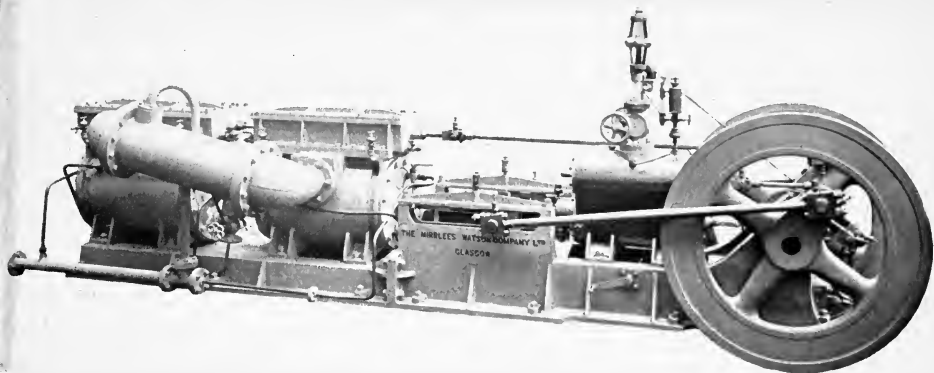

PLATE 26A.—Two-stage Horizontal Steam-driven Slide-valve Dry-air Pump, by the Mirrlees Watson Co., specially designed for high vacua.

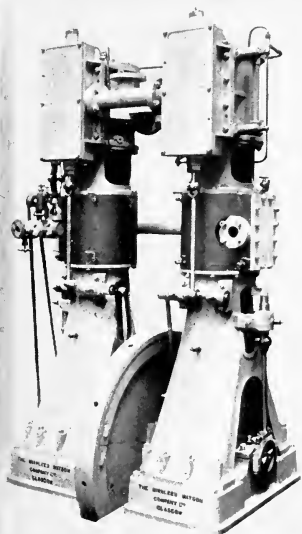

PLATE 26B.—Two-throw Steam-driven Slide-valve Dry-air Pumps, made by Mirrlees Watson Co. The Air Pumps are seen above the Steam Cylinders.

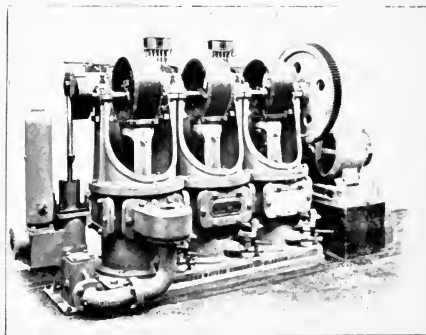

PLATE 26C.—Three-throw Edwards' Air Pump, Electrically Driven, with single acting Hot-well Pump, shown on the left, driven from the Air-pump Shaft. [To face p. 352.]



of the author. The first set of curves also throw a very interesting light upon the steam consumption and of coal consumption, with one

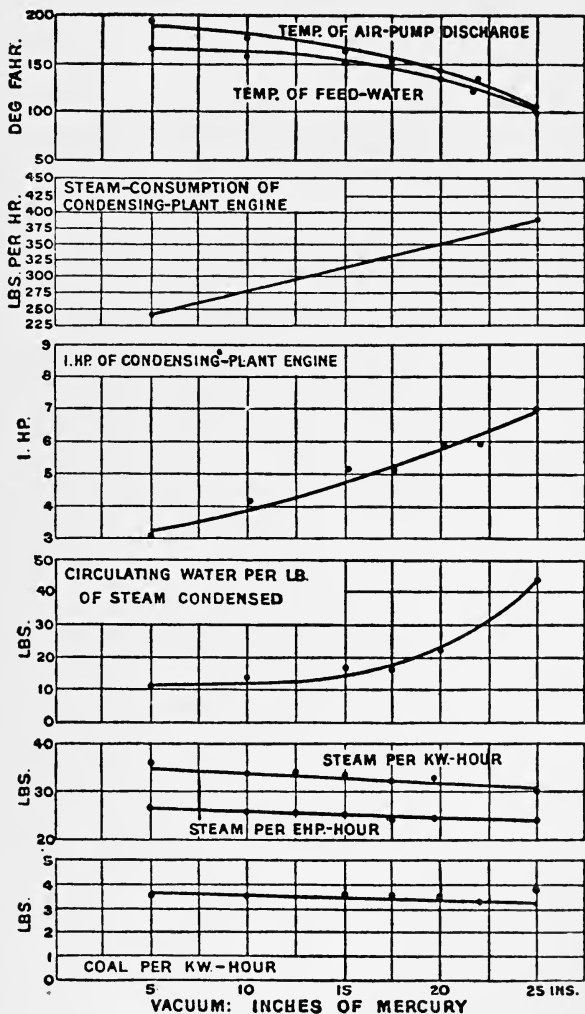

FIG. 170.—Curves showing Steam and Coal Consumption, etc., from 5" to 25" Vacuum, with one engine working, in Mr. Richard Allen's experiments. (*Trans. Inst. C.E.*)

engine working with increasing vacuum, from 5 up to 25 inches. In Fig. 170 is given the steam consumption per K.W. hour, and per

electrical H.P. hour, also the coal consumption per K.W. hour, with the engine employed on the tests, and with vacua from 5 up to 25

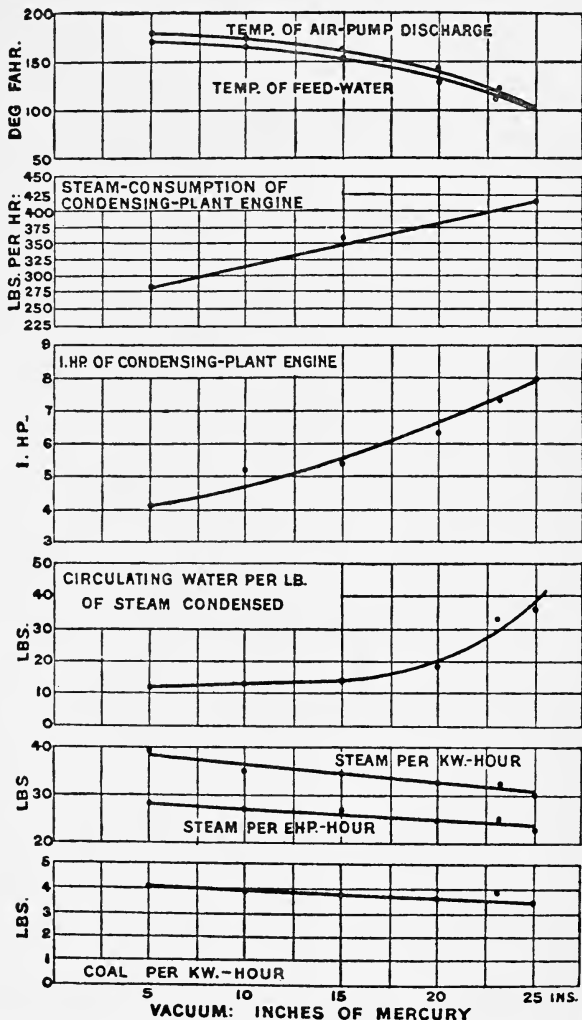

FIG. 171.—Curves showing Steam and Coal Consumption, etc., in Mr. Richard Allen's experiments, with Vacua varying from 5" to 25", and with two Engines running. (*Trans. Inst. C.E.*)

inches. It will be noticed that both the steam and coal consumption steadily decrease, as shown by the inclination of the curve, which is

practically a straight line in the three cases, as the vacuum increases, and Mr. Allen draws the conclusion from it, that while it is probable that if condensing with high-speed reciprocating engines were carried to a higher vacuum, further economies would result, but that as this would mean increase in size of engines, increased loss by radiation, and so on, he is of opinion that a vacuum of 25 to 26 inches of mercury

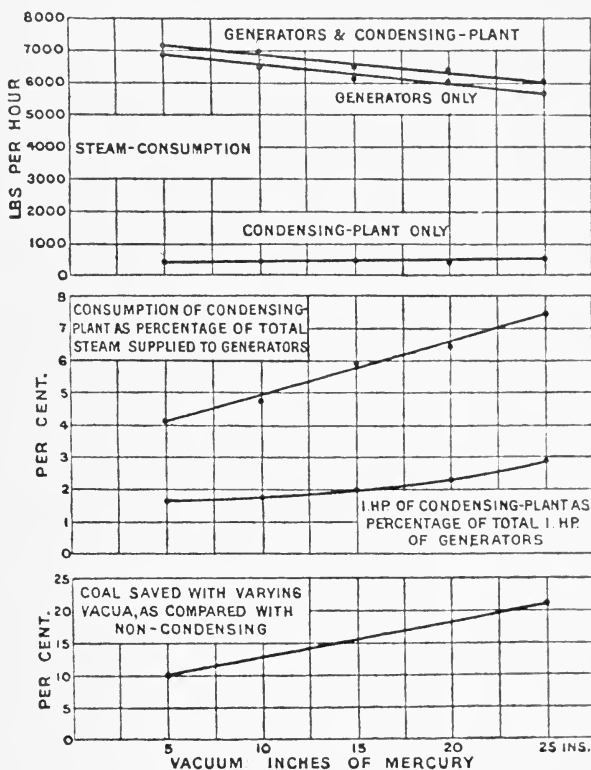

FIG. 172.—Curves showing Coal saved, and consumption of Steam and Condensing Plant, in Mr. Richard Allen's experiments with two Engines working. (*Trans. Inst. C.E.*)

is about the economic limit. This is the conclusion that practically the whole of the engineering world who are engaged in the manufacture of reciprocating engines have come to. In Fig. 170 is also given the quantity of circulating water per pound of steam condensed, from 5 up to 25 inches vacuum, and, as will be seen, it increases from about 11 lbs. at 5 inches up to 45 lbs. at 25 inches. Fig. 171 shows curves

for the steam consumption per K.W. hour, and per E.H.P., and the coal consumption per K.W. hour, with two engines working, and with vacua from 5 to 25 inches of mercury. It will be noticed that the decrease in steam and coal consumption is more marked with the two engines than with the one. Fig. 171 gives the circulating water per pound of steam condensed with the two engines working, and it will be seen that the result is rather more favourable than with a single engine. Fig. 172 shows the indicated H.P. of condensing plant, and the consumption of steam by the condensing plant, with varying vacua, as percentages of the total steam and total power supplied to the test engines, which were employed in driving electricity generators and the percentage of coal saved, with varying vacua, as compared with the coal that would be consumed when not condensing. It will be seen that the consumption of steam by the condensing plant increases from 4 per cent. with 5 inches of vacuum, to  $7\frac{1}{2}$  per cent. with 25 inches, while the indicated H.P. taken by the condensing plant, increases from about  $1\frac{2}{3}$  per cent. to nearly 3 per cent., the coal saved being 10 per cent. with 5 inches of vacuum, and about 21 per cent. with 25 inches of vacuum.

It will be understood, of course, that these economies apply to the special apparatus under test, which consisted of two compound engines, 12- and 21-inch cylinders by 9-inch stroke, driving electricity generators of 165 and 137.5 K.W., but the author believes the tests to be fairly representative. Fig. 173 shows the variation in the quantity of cooling water, with its initial temperature for the different vacua shown.

Mr. Allen estimates that for vacua of 25 to 26 inches, with the barometer at 30 inches, the tube surface in the condenser for circulating water having a temperature not exceeding  $65^{\circ}$  F. at inlet, should be from  $\frac{1}{9}$  to  $\frac{1}{10}$  square foot per pound of steam condensed, and with circulating water at higher temperature, from  $\frac{1}{8}$  to  $\frac{1}{9}$  square foot per pound of steam. It will be noticed that these figures agree practically with those given by Mr. Parsons. Further, Mr. Allen estimates that for the vacuum mentioned the volumetric capacity of the air pumps measured by the number of cubic feet displaced by the piston, should not be less than 0.6 cubic foot per pound of steam handled.

Mr. Allen also carried out a further series of tests, with the object of estimating the cooling water required to obtain higher vacua, with different initial temperatures, and with different condenser surfaces. The tests were carried out on the same condenser, different quantities of steam being passed through the condenser in the same time, to vary the quantity dealt with per square foot. Thus 1500 lbs. of steam per hour were passed through, giving 5 lbs. of steam per square foot of tube surface, 2000 lbs. per hour, 2500 lbs. per hour, and 3000 lbs. per hour, the quantity of steam dealt with per square foot of tube surface



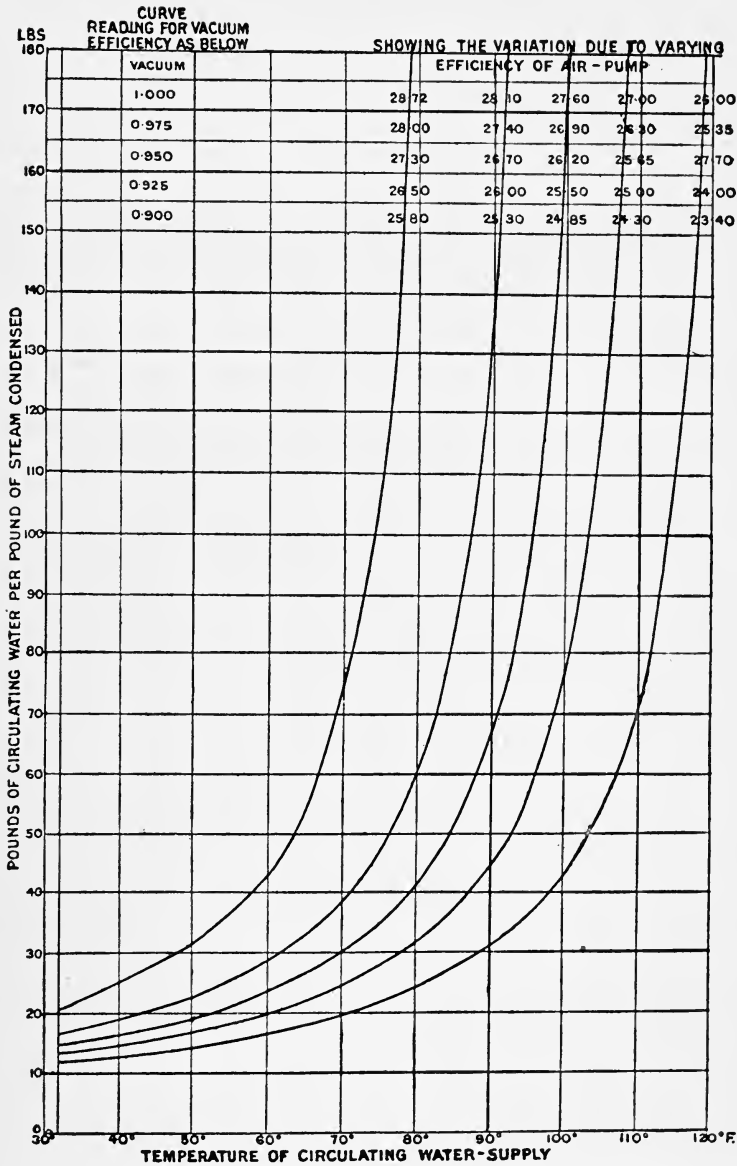
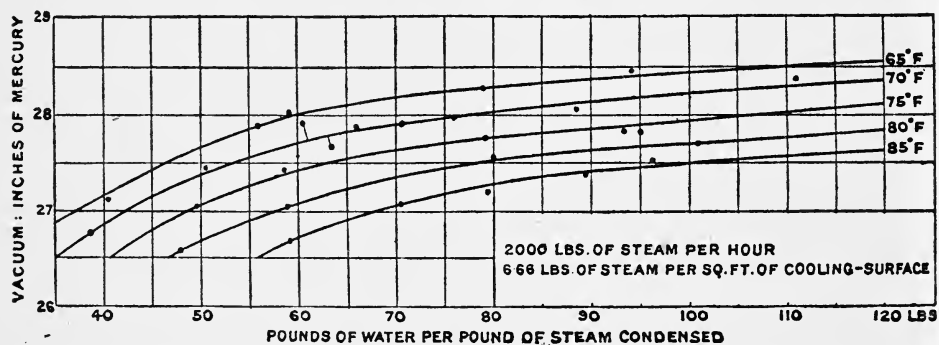
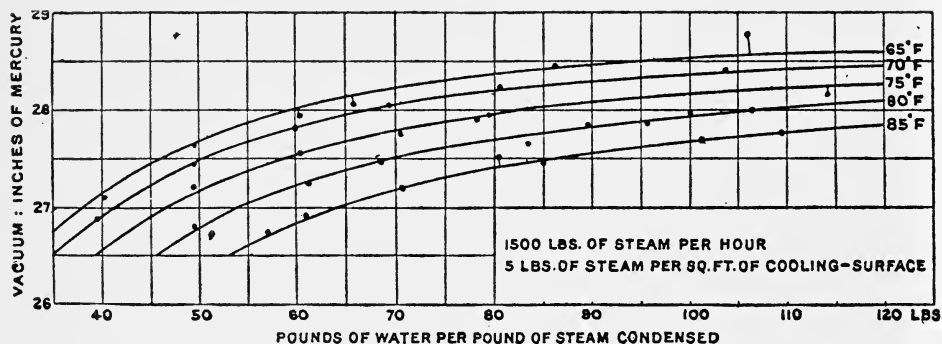

FIG. 173.—Curves showing the quantities of Circulating Water, with different Vacua, and different Initial Temperatures, in Mr. Richard Allen's experiments. (*Trans. Inst. C.E.*)

being in proportion to these figures. The curves given in Figs. 174 and 175, 176 and 177 show the quantities of circulating water at initial temperatures of 65°, 70°, 75°, 80° and 85° F., and with vacua ranging from 26½ inches up to about 28·6 inches of mercury. It will be noticed in Fig. 174, in which 5 lbs. of steam was dealt with by each square foot of cooling surface, that the quantity of cooling water with an initial temperature of 65° F. increases from 35 lbs. per pound of steam condensed with 26½ inches vacuum, to 70 lbs. with about



Figs. 174 and 175.—Curves showing the different quantities of Circulating Water, with different Initial Temperatures and different Vacua, in Mr. Richard Allen's experiments. (*Trans. Inst. C.E.*)

28½ inches, to 95 lbs. with 28½ inches, and to 120 lbs. with about 28·7 inches. With water at 70° F. initial temperature, the quantity rises from 35 lbs. with 26½ inches vacuum, to 120 lbs. with about 28·4 inches vacuum, no higher vacuum apparently being obtainable with the water available at that temperature. With smaller proportion of cooling surface, or what amounts to the same thing, larger quantities of steam dealt with per square foot of cooling surface, the results are very accentuated, and again the results are more accentuated with

cooling water of higher initial temperatures. Thus with 10 lbs. of steam per square foot of cooling surface, the quantity of cooling water with an initial temperature of 65° F. is about 37 lbs., and it increases to 70 lbs. with 28 inches vacuum, and to 120 lbs. with 28.3 inches, which is the highest vacuum apparently obtainable. With water having an initial temperature of 85° F., 64 lbs. about are required for 26½ inches vacuum, and 78 lbs. with 27 inches, 120 lbs. with 27.3 inches, the highest obtainable. These figures appear to the author

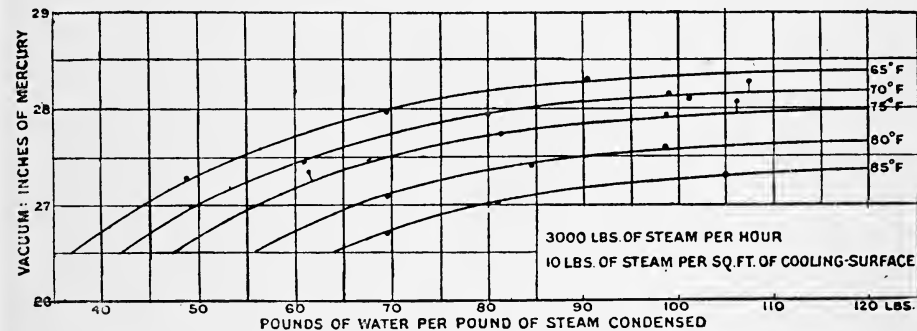
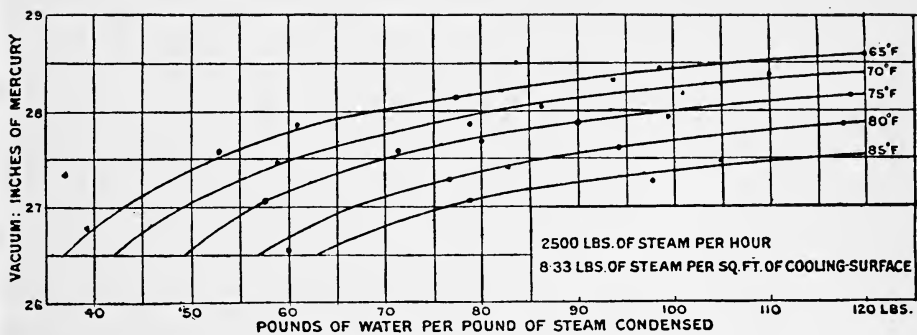

FIGS. 176 and 177.—Curves similar to Figs. 174 and 175, but with smaller Tube surface per pound of Steam condensed. (*Trans. Inst. C.E.*)

to be very striking and very instructive, because it must not be forgotten that in addition to the quantity of water that must be provided, for the higher vacua, and with the higher temperature, and the cost of providing the water, as apart from the cost of driving it through the condenser, the charges for pumping will increase very rapidly with the larger quantities. It will be remembered that with a given set of tubes the frictional charge for driving the water through them, increases as the square of the velocity, which means,

of course, that the frictional charge will increase with the square of the quantity of water passing through the condenser in a given time.<sup>1</sup>

### Prof. Weighton's Experiments on Condensers

Professor R. L. Weighton, of the Armstrong College, Newcastle-on-Tyne, has carried out a very interesting series of experiments in the engineering department of the Armstrong College, designed primarily to compare the efficiency of the Contraflo condenser with the ordinary form of surface condensers. Incidentally, however, the experiments, which are very much on the lines of those carried out by Mr. Richard Allen, throw a very important light upon the question of the efficiency of surface condensers generally, and upon the quantity of water required, with varying initial temperatures, varying final temperatures, and varying vacua. In addition to comparing the old form of condenser with the Contraflo, Professor Weighton carried out some experiments upon the Contraflo condenser, with solid wooden cores of triangular section inserted in the condenser tubes. The condenser tubes were of the usual form,  $\frac{3}{4}$  inch external diameter by 4 feet long, the tubes being  $1\frac{1}{8}$  inches apart from centre to centre, in the Contraflo form, and  $1\frac{7}{16}$  inches in the old form. The wooden cores were about 2 inches longer than the tubes, and were merely inserted in the tubes without any fastening whatever. The effect of the wooden core was to reduce the available space for the passage of the water in the tubes, and therefore to reduce the quantity of water passing under any given pressure. It will be noted that this experiment is on the lines of what has been mentioned in several parts of this book, as the ideal condition for the transmission of heat from one fluid to another, when the two fluids are separated by a metal diaphragm, the ideal condition being that a thin stream of each fluid shall pass on opposite sides of the diaphragm in opposite directions. The effect, however, of the cores inserted in the tubes was, in addition to decreasing the available space for the passage of the water, to increase somewhat considerably—to nearly double in fact—the frictional charge for the passage of the water through the tubes. It will be remembered that the frictional charge depends directly upon the extent of the surface over which the water runs, and it will be seen that this surface is increased by the three sides of the equilateral triangle formed by the cores. It appears to the author that the results obtained by Professor Weighton point to a different form of tube, viz. one having the same area as the reduced area in the tubes, but without the increased surface, and that this might be obtained by either an elliptical or plainly flat tube. There are, of course,

<sup>1</sup> Mr. Allen informs the author that since the above experiments were made, his firm have succeeded in reducing the quantity of circulating water for high vacua.

constructional difficulties in the way of adopting a form of tube of this kind, but it appears to the author that something of the kind might be tried. Professor Weighton found that the temperatures of the water in the hot well, for all degrees of vacua exceeding 26 inches, were from  $10^{\circ}$  to  $15^{\circ}$  lower with the old type of condenser than with the Contraflo, and he points out that there is no advantage in having the temperature of the water in the hot well lower than is necessary, that, in fact, the lower the temperature, the lower is the efficiency of the steam system as a whole; because if the water from the condenser has to be used for boiler feed, every degree of lower temperature has to be made up at the expense of a heating from the boiler furnace. Professor Weighton found that an air pump capacity of 0.7 cubic feet per pound of steam condensed was as large as was necessary, providing that the leakage of air into the condensing system was prevented. On the other hand, he found that with air leakage, the air pump power required was increased very rapidly. He also found by using a dry air pump, a considerable economy of condensing water was obtained, but at the cost of increased pump capacity. He sums up the conclusions at which he arrived from his experiments as follows:—

(1) Efficiency is increased in a surface condenser by the removal of the condensed water immediately it is formed.

(2) Condenser efficiency is obtained with a minimum condenser capacity consistent with the necessary surface.

(3) Efficiency is obtained by fairly high speed of circulating water.

(4) The temperature of the condensing water at the discharge may be equal to, or slightly higher than the temperature due to the vacuum.

(5) The temperature of the hot well may be from  $3^{\circ}$  to  $5^{\circ}$  higher than the temperature due to the vacuum.

(6) That with a reasonably air-tight system, an air pump capacity of 0.7 cubic feet per pound of steam is sufficient, up to close upon 29 inches vacuum.

(7) With dry air pumps, a vacuum of  $28\frac{1}{2}$  inches may be obtained at a condensation rate of 20 lbs. of steam per square foot of condenser surface per hour, and with 24 times the quantity of cooling water at an inlet temperature of  $50^{\circ}$ .

(8) With dry air pumps, a condensation rate of 36 lbs. of steam per square foot of condenser surface per hour can be obtained with condensing water 28 times that of the steam condensed, with a vacuum of  $28\frac{1}{2}$  inches, at an inlet temperature of  $50^{\circ}$ .

Figs. 178 and 179 give some of the curves obtained by Professor Weighton, and they show, as explained above, the effect of the initial temperature of cooling water, the speed of the cooling water, and the vacuum obtained.

It will be noticed that Professor Weighton uses cooling water of temperatures from 45° to 70° F., while Mr. Richard Allen used cooling

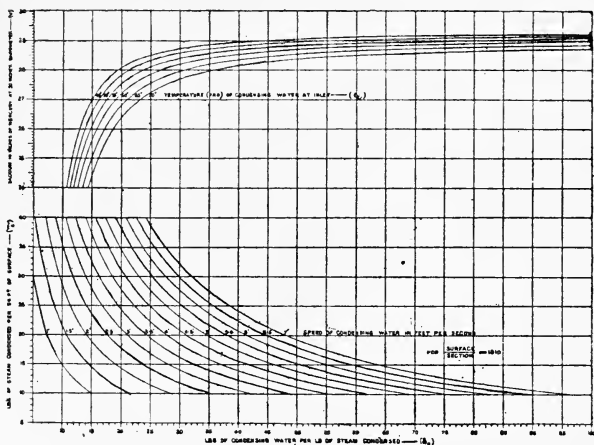

FIGS. 178.—Curves showing the results of Prof. Weighton's experiments, in quantity of Circulating Water required, and speed of the Circulating Water, with cores in the Condenser Tubes. (*Trans. Inst. N.A.*)

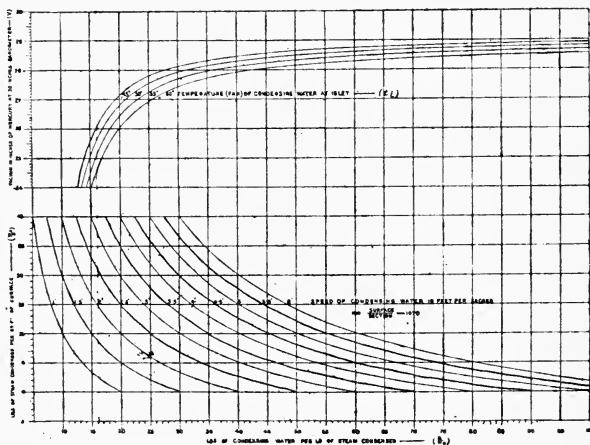

FIG. 179.—Curves showing the results of Prof. Weighton's experiments, in quantity of Circulating Water required, and its speed, without cores in Condenser Tubes. (*Trans. Inst. N.A.*)

water of temperatures from 65° to 85°. Professor Weighton's curves showing the quantity of water required for different vacua are much steeper in the early portion than those of Mr. Allen, but this arises from

the fact that his curves commence with a vacuum of 22 inches, while Mr. Allen's commence with  $26\frac{1}{2}$  inches, and it will be seen that the curves are of practically the same form, after  $26\frac{1}{2}$  inches, though differing in position on the diagram, as Mr. Allen's.

With No. 3 condenser, with which the greater portion of the experiments were carried out, and with cores in the tubes, and which apparently was best suited for the quantity of steam delivered by the experimental engine, the quantity of water required, with an initial temperature of  $45^{\circ}$ , rises from 12 lbs. per pound of steam condensed at 24 inches vacuum, to 15 lbs. at 27 inches, to 18 lbs. at 28 inches, and after that increases very rapidly, as the vacuum rises. The effect of the cores in the tubes is fairly marked, as will be seen from the different curves.

In Fig. 180 Professor Weighton has given the cost in circulating water H.P. of the attainment of given vacuum, under different conditions, from which it will be seen that the pump H.P. rises very rapidly after 28 inches vacuum is reached.

Fig. 181 gives the limit beyond which the power absorbed in pumping exceeds that given to the engine by the higher vacuum.

## Pumps for Condensers

As indicated above, two pumps are required for nearly every form of condenser, one to supply the cooling water, and the other to remove the condensed products. For the cooling water almost any form of pump may be employed, a favourite form being the centrifugal pump, arranged for a low head, which may be driven conveniently by an electric motor, or a high-speed engine of any convenient form, or again by a belt or gearing from the shaft of the engine. Plunger pumps are also employed for the circulating water, and they may be of single, double, or triple barrel, and driven by an electric motor, or any convenient source of power again. As the quantity of circulating water varies with the load that is on the engine the condenser is working with, the circulating pump should be capable of having its speed varied, within certain limits, unless it is also arranged that the engine is always working at a certain proportion of its full power, a condition that very rarely occurs. Variation of speed of the pump may be accomplished in the case of the electric motor by varying the excitation of the field magnets, and in the case of the steam engine by varying the pressure of steam, by the aid of the stop valve. The quantity of water may also be varied by the use of one of the pumps with variable stroke, on the market, keeping the speed of the pump itself constant. With plunger pumps the quantity of water thrown by each plunger can be varied by varying the length of the stroke

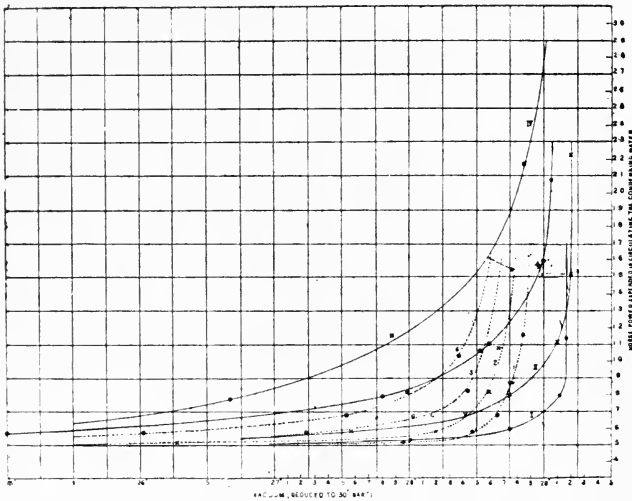

FIG. 180.—Curves showing the cost in H.P. in circulating the Cooling Water, with varying Vacua, and with cores in Condenser Tubes and without, as given by Prof. Weighton's experiments. (*Trans. Inst. N.A.*)

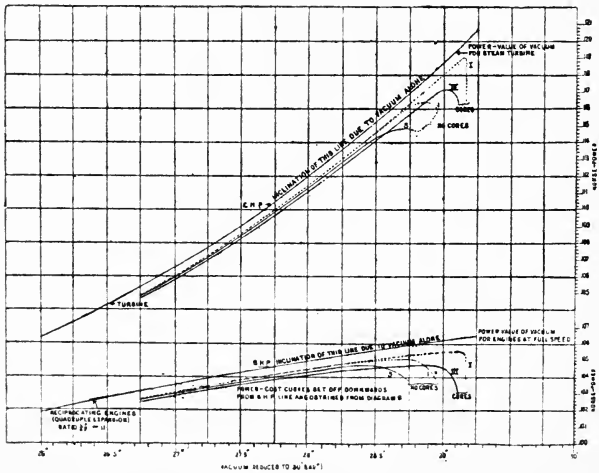

FIG. 181.—Curves showing, by Prof. Weighton's experiments, the limit beyond which the power expended in pumping the Circulating Water exceeds that conferred by the higher Vacuum. (*Trans. Inst. N.A.*)



and keeping the speed constant, or by varying the speed keeping the length of stroke constant. Up till recently the universal method was varying the speed, but with the advent of the variable stroke pumps introduced by Messrs. Mather & Platt and Hayward, Tyler & Co., the speed can be maintained constant, while the stroke is varied. This arrangement is very convenient for driving with electric motors, and it is also convenient for driving by means of steam engines, as it enables the self-governing property of the electric motor to be made use of, and also in the case of the steam engine, enables the governor to be set for a certain speed, and allows the governor to take charge of the engine. Plate 24A shows the condenser of a set of large blowing engines at a steel works; Plate 24B a large double-acting horizontal steam pump; 25A a pair of Mirrlees Watson vertical steam pumps; 25B and 25D, two of Hall's vertical steam pumps; and 25C a surface condenser, with air and circulating pumps.

## Air Pumps

The air pump is a different apparatus to the circulating pump. It is called the air pump because, though it also in the majority of cases removes the condensed water from the condenser, the volume of air which comes over with the steam, and which it is of the greatest importance to remove, in order that vacuum may be obtained, is so much greater than that of the water.

There are practically two forms of air pumps, one designed to remove the air only, and the other designed to remove the air and water, the two forms being employed in the cases for which they are adapted, the dry air pump as it is called being used where no water is present, and the wet air pump where condensed water has to be removed as well as air.

The dry air pump, the pump which removes air only from the condensing plant, is really an air compressor. It withdraws air from the condenser by suction, just as an air compressor draws air from the atmosphere by suction, and it delivers the air to the atmosphere after compressing it to a certain figure, just as the air compressor delivers the compressed air to a receiver. The dry air pump consists of a cylinder with a piston, and driven by any convenient source of power, usually its own engine. The dry air pump is often worked in two stages, very much as air compressors are, the air being drawn into the first stage merely, then cooled, and ejected in the second stage. Forms of dry air pumps are shown in Plates 26A and 26B. The value of the arrangement is due to the fact that, with high vacua, the air pump has to force the condensed products out against the pressure of the atmosphere, and the work is more easily accomplished

where the second stage shields the first, and where the volume of the air and incombustible gases is reduced by cooling before being ejected.

## Bucket Air Pumps

**Edwards Air Pump.**—In the Edwards air pump, a section of which is shown in Fig. 182, and which is

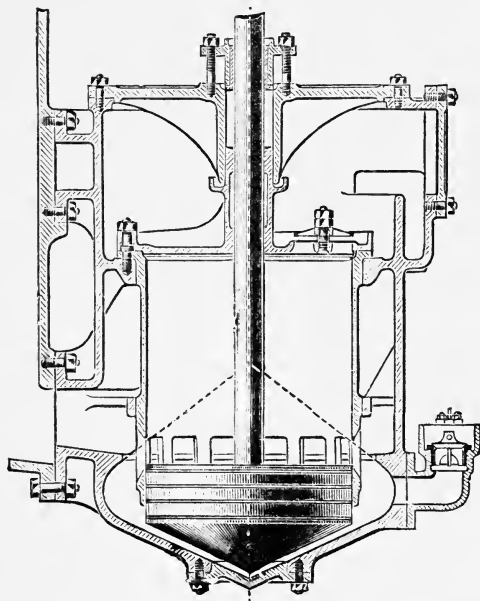

FIG. 182.—Section of Edwards Air Pump, showing the Form of the Piston.

used very largely for condensing purposes, it is claimed that the arrangement has been very much simplified by the removal of bucket and foot valves that were employed in the earlier forms of air pumps. As will be seen from the drawing, the moving portion of the pump, that which corresponds to the piston in other pumps, is shaped conically in the lower part and cylindrically above, and the bottom of the pump vessel is also conically shaped to fit the bucket. The bucket, or piston, moves up and down in the central barrel shown, and the condensed water and air flow into the bottom of the pump chamber through the aperture on the left, when the bucket is off the bottom.

As the bucket descends, it forces the air and water up into the barrel above the bucket, through the ports, which are exposed, immediately above the cylindrical portion of the bucket. When the bucket has completed its downward stroke and has expelled all the water in the chamber below, having forced it into the circular chamber above, it commences its up stroke, closing the ports through which the water and air entered, as it rises, then forcing the whole of it upwards, and discharging them through the valve at the top of the barrel. It will be understood that the problem of forcing air and water out is very much more difficult, that is to say, it requires very much more accurate working between the pump bucket and the stationary parts

of the pump than one in which merely water is to be handled. If the air is to be expelled, the pump must work air-tight, and this is what is claimed for the Edwards air pump. It is also claimed that the Edwards pump, dealing with the water mechanically, does not depend upon the pressure in the condenser to drive it into the pump, and secondly an increase of speed does not impair its efficiency. The question of the elimination of back pressure in the engine cylinders is closely bound up with the working of the air pump, and consequently it is claimed that the Edwards pump accomplishes this. In the Edwards pump the speed at which the water is propelled is necessarily the same as that of the bucket which forces it. Plates 26C, 27A and 27B show forms of Edwards air pump made by Mirrlees Watson, and Plate 27C a complete standard surface condensing plant, with air and circulating pumps.

## Cooling the Circulating Water for Condensers

As already explained, the question of the use of condensers with steam engines is one of relative economy, in which a balance-sheet should be made out. On the one hand, by condensing the exhaust steam, a certain amount of coal is saved, owing to the lessening of the back pressure in front of the piston on its return stroke, and a further saving is often effected by utilizing the condensed water, which is at a comparatively high temperature for feeding the boilers. On the other hand, as explained, condensers require circulating pumps for forcing the water through the condensers, whatever the form may be, unless there happens to be a supply of water at a sufficient height to force it through the condenser, a thing that will not often happen. In nearly every form of condenser also an air pump is necessary, and this also absorbs a certain amount of power.

With an abundant supply of cheap water, the economy of condensing in the great majority of cases is very marked. It has been estimated that the saving in coal and water by condensation ranges from 25 per cent. with steam at 150 lbs. pressure, to 35 per cent. with 70 lbs. pressure, and this does not represent the whole of the saving, as less steam being required, owing to the absence of back pressure, smaller boiler plant may also be used, effecting a saving in the capital account. Condensing plant is also estimated to take from 1 to 7 per cent. of the power furnished by the engine to drive the circulating and air pumps, the power required varying with the conditions. But all of this economy may easily be neutralized in a very large number of cases by the heavy cost of circulating water. Towns water is *always* too expensive for economical condensing. Waterworks engineers are faced with greater and greater demands for water in all

the large towns for the ordinary domestic consumption, and are being obliged to lay out more and more ambitious schemes to provide it, and they do not want, and will not have if they can avoid it, any consumption, especially large consumption, such as would rule with condensing plant, outside of domestic consumption. Hence charges for water from towns supply are always prohibitive. It often happens also that the cost of pumping from a river which is at a distance, or from springs at a distance, is considerable and in those cases it is often an open question whether condensation is economical, while the condensing plant is an additional apparatus to be looked after. But the trouble can usually be completely overcome, and is overcome in a great number of instances, by the adoption of cooling apparatus for the circulating water. The circulating water in passing through the condenser has its temperature raised  $20^{\circ}$  F. and upwards, and if it can be reduced again to the initial temperature, or by a substantial

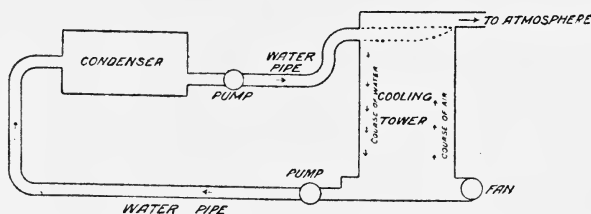

FIG. 183.—Diagram showing the Course of the Water when a Cooling Tower is used, in connection with a Condenser.

number of degrees, it may be employed over and over again, with a small loss in the process of cooling; with proper appliances, the cost of the cooling water then being the cost of the water required to make up the loss by evaporation, plus the interest on the cooling plant and the cost of running it. Fig. 183 shows diagrammatically the arrangement of a condenser and a cooling tower. The diagram applies to any form of cooling appliance, if the fan is omitted.

## Cooling Ponds

The simplest form of cooling apparatus is that which is employed so largely in Lancashire, in connection with the cotton mills, viz. a pond in the neighbourhood of the engine house, into which the cooling water is discharged after passing through the condenser, and from which the circulating pump takes its suction. It has been estimated that cooling ponds used for the purpose must have a store of 450 gallons per indicated H.P. and that they should have a surface

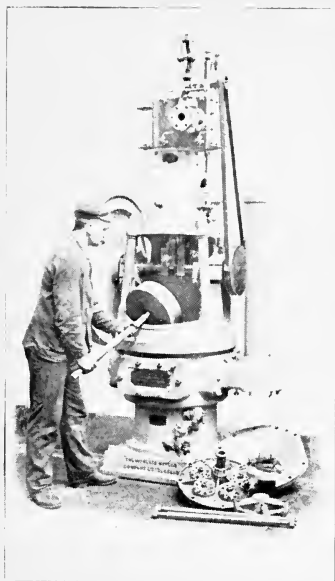

PLATE 27A.—Single-throw Vertical Edwards' Air Pump, by Mirrlees Watson, with working parts being taken out for inspection.

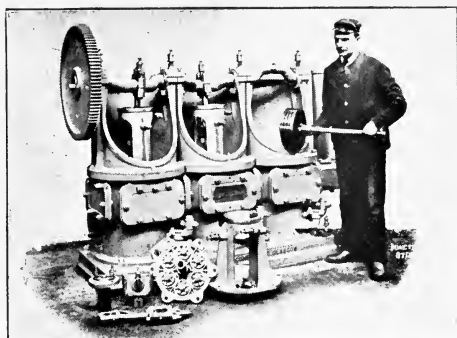

PLATE 27B.—Three-throw Vertical Edwards' Air Pump, with working parts exposed. Made by the Mirrlees Watson Co.

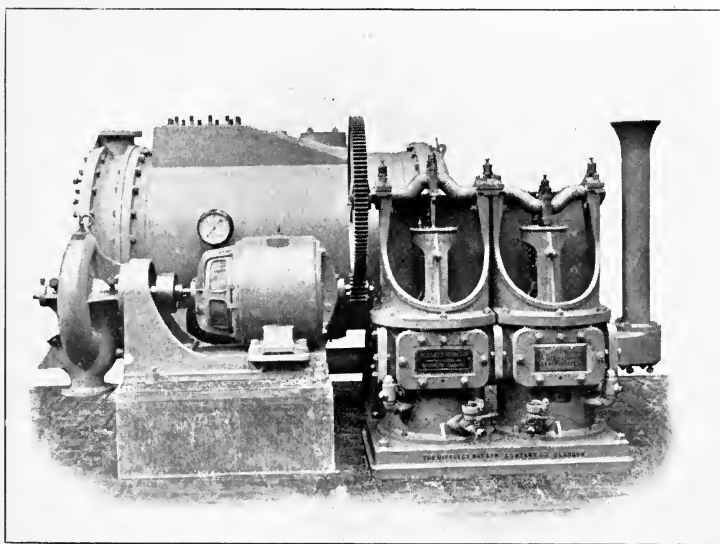

PLATE 27C.—Mirrlees Watson standard arrangement of Surface Condensing Plant, with Two-throw Edwards' Air Pump and Centrifugal Circulating Pump, the two Pumps driven by one Electric Motor, as shown. [To face p. 368.]



of 26 square feet per indicated H.P. for day running only, and 52 square feet for day and night running. The pond or reservoir should be divided into sections, if possible, or at any rate it should be arranged that the suction water for the condenser shall be taken from a point as far as possible from that at which the heated water from the condenser is delivered, and where possible, baffles or other obstructions should be introduced to prevent the passage of the heated water directly to the suction pipe of the circulating pump.

The cooling of the water in the cooling pond is effected by the evaporation which takes place from the surface of the pond, and it will be greatest in hot weather, providing that the atmosphere is not heavily impregnated with moisture. Evaporation takes place from the surface of any body of water, directly in proportion to the surface of the water exposed, and also directly in proportion to the difference of tension of the vapour issuing from the water, and that already present in the atmosphere. When the atmosphere contains only a small proportionate quantity of moisture, the tension of its vapour will be comparatively low, and evaporation will go on comparatively freely, the cooling effect being approximately 10,000 heat units for every gallon of water evaporated. In the muggy weather we are familiar with, and which is sometimes common in summer, the mugginess of which is due to the saturation of the atmosphere with moisture, the tension of the vapour in the atmosphere is high, and it may be so high in comparison to that of the vapour emanating from the surface of the pond, that no evaporation takes place, and even that deposit of vapour takes place in the pond from the atmosphere. It is estimated that with a good reservoir and pipes, one gallon of water per indicated H.P. hour is lost by evaporation from the pond while the engines are running.

### Cooling Ponds with Nozzles

An extension of the simple cooling pond is a pond in which pipes are stretched across, slightly above the surface of the pond, usually at right angles to each other, nozzles being placed at intervals above the pipes, and the water to be cooled being driven through the nozzles, carried up a certain distance into the atmosphere in the form of a spray, and falling down to the surface of the water. The nozzles may give a simple spreading motion, similar to that of the rose of a watering-pot, or they may give a whirling motion by passage through a nozzle having a screw section, the whirling motion being claimed to give an increased spreading to the spray, as it issues from the nozzle. The object of spraying the water is to break it up and to expose the individual particles, as far as possible to the action of the air in the neighbourhood. Air has a

certain capacity for moisture, as already explained, but it can exercise this capacity, and can abstract moisture only from the surface of any body of water with which it is in contact. Thus, in the case of a pond, evaporation can only take place from the water on the surface, while when the water is formed into the fine spray, mentioned, a certain amount of evaporation may take place from each of the particles into which it is broken up, provided that the air in the neighbourhood is not already saturated. It will be understood, of course, that evaporation is going on from the surface of the pond, above which the nozzles project, as well as from the spray into which the issuing water is formed, and the result should be that a smaller pond should be able to do the work.

A further extension of the pond and spraying nozzle method, which is sometimes employed is, the water is carried in pipes to a height of about 6 feet above the surface of the pond, and is there sprayed, and allowed to fall in jets on to the surface of the pond. One of the objections to spraying water in the manner described, which applies more particularly to the method in which the water is carried to a considerable height above the surface of the pond, is that when any wind is blowing, a somewhat serious percentage of the water is carried off by the wind. It has been mentioned that the air absorbs moisture, and when air is travelling, as when a wind is blowing, it carries the moisture it absorbs away with it. The moist south-west winds that we are so familiar with in nearly every part of these islands, are striking instances of this, the wind having absorbed moisture from the sea over which it has passed, and delivering it to the earth when it arrives. The difficulty may be overcome, and is in later forms of cooling apparatus, arranged upon these lines, by enclosing the pond by a system of louver boards, fixed between uprights, and so arranged that they can be opened or closed at will. Louvre boards are similar to venetian blinds. They consist of thin boards, held between uprights, and arranged to move from a horizontal position, when air passes freely between them, to the position in which they lie close together, like slates upon a roof, and when very little air can pass. By fixing louver boards all round the pond, or on those sides against which the prevailing winds blow, and arranging to move the boards as required, the cooling plant can be controlled, and the loss minimized.

## Cooling Towers

Another method of cooling the circulating water is by the aid of what are termed cooling towers. They are towers of various forms, and of various designs, but all have the one thing in common, that



the water to be cooled is pumped, either to the top of the tower, or to a point at a considerable height above the ground, and is there allowed to find its way down to the surface of the ground, but in doing so is broken up into as fine particles as possible, and during the course of its descent is exposed to a current of air, the air absorbing moisture in the form of vapour from the descending water, the heat necessary to convert the water into vapour being taken largely from the water itself.

## Cooling Towers without Vertical Draught

The simplest form of cooling tower is that in which the action of the wind is depended upon entirely for the evaporative and cooling

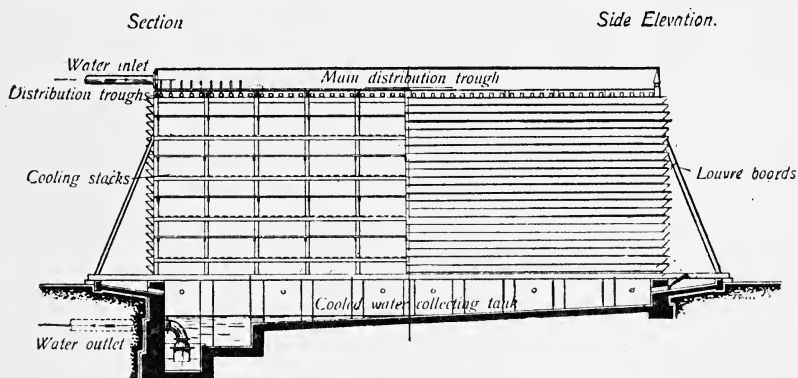

FIG. 184.—Cooling Tower, for Wind Draught, made by Messrs. Balcke & Co. The Boards over which the Water drips are shown on the left of the Figure, the Louvre Boards on the right.

effect. In this form of tower the apparatus for breaking up the water into fine drops, descriptions of which are given below, is built usually on top of a building, where such space is available, in a rectangular form, and in the later patterns is surrounded by walls of louvre boards, as explained in connection with cooling ponds. The louvre boards are opened and closed, according to the force of the wind, and evaporation takes place by the action of the wind, passing through the laths, etc., used for breaking up the water into fine drops, just as in the case of the pond with spraying apparatus. The objection to this form of apparatus is similar to that ruling with chimneys. In order that it may be under the control of the engineer, it must be made large enough to cool the necessary quantity of water for condensing purposes, under the conditions of

largest power service, and also under the conditions of lowest evaporating effect in the atmosphere. It is doubted by many engineers, whether the additional cost rendered necessary to meet these conditions, combined with the comparative uncertainty of the control of the evaporative effect, especially where wind is frequently changing, does not more than neutralize the additional cost of other plant. Fig. 184 shows one of these cooling towers.

In the more frequent arrangement of cooling towers a draught is provided, carrying the air through the body of the tower, very much in the same manner as a draught is provided for a boiler furnace, and, as in that case, there are two methods of providing the draught. It can be furnished by a chimney, or by fans. Chimney draught is less expensive to maintain, and also usually involves a smaller capital outlay, but it has the same limitations as chimney draught for boiler furnace. It is not possible to increase the draught, if it should be necessary to do so, beyond the capacity of the chimney to furnish the draught, and it is also subject to the further drawback, common with the furnace chimney, that the state of the atmosphere outside of the chimney, will change the draught inside the chimney.

### Chimney Cooling Towers

As explained above, the chimney cooling tower provides for the passage of air through the body of the tower, and therefore provides the necessary air to cause evaporation of the water that is to be cooled, by creating a difference of pressure between the bottom of the tower and the outlet at the top of the chimney, and this difference of pressure is created as in the boiler chimney, by the difference in weight between the column of air in the chimney, plus that in the body of the tower itself, and the equivalent column of air outside of the chimney. In the case of the cooling tower, there is not the high temperature available that exists in the boiler furnace, and it is not possible to produce a volume of hot gases, as is done in that case, but the equivalent is obtained by the air which has passed through the body of the tower, and which has come in contact with the water that is being cooled, having its temperature raised, and further, by a portion of the volume previously occupied by the air being now occupied by the vapour of water. It was explained in the first chapter, that the different heights at which the barometer stands, and which weather-wise people have come to regard as indicating fine or wet weather, is due to the fact that when moisture is present in the atmosphere, it displaces an equivalent portion of air, within any given space, and therefore the column of air and moisture standing above any particular point on the surface of the earth, where a

barometer may be fixed, will decrease as the percentage of moisture it contains, increases, and as the percentage of moisture increases, the probability of rain also increases. The same thing applies to the cooling tower, the increased quantity of moisture present in the air within the tower, causes it to be lighter than the equivalent column of air outside of the tower, and this creates the necessary difference of pressure to force

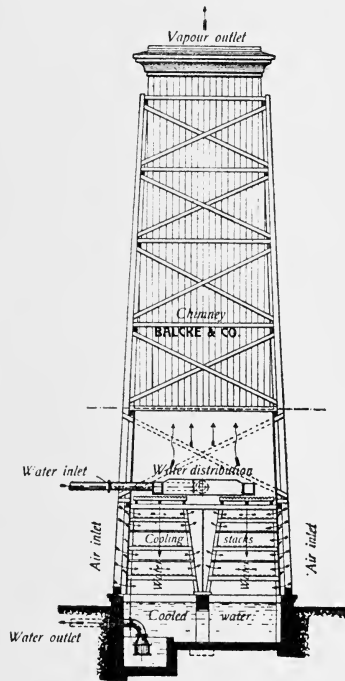

FIG. 185.—Section of Chimney Cooling Tower, made by Messrs. Balcke. The Air Current is in the opposite direction to the Water Current. The Chimney is of Wood.

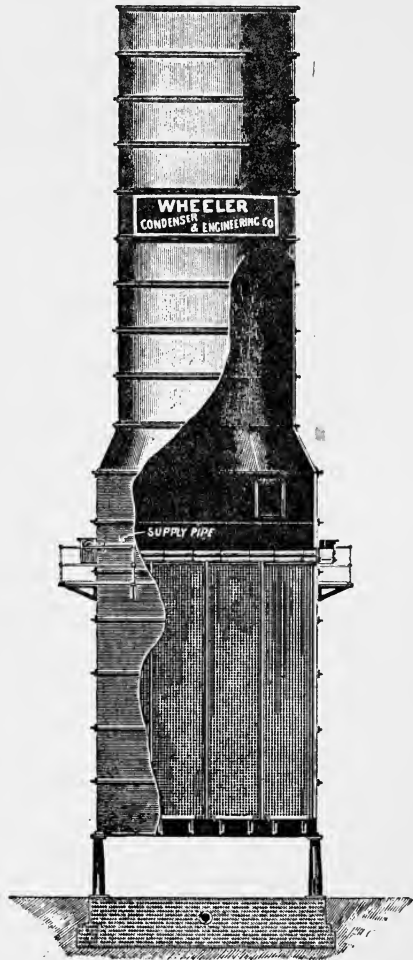

FIG. 186.—Barnard Chimney Cooling Tower. The Cooling Appliances consist of Galvanised Iron Mats, arranged vertically, and the Chimney is of Iron.

the air through the tower. The difference of pressure in the chimney cooling tower is usually not great. It will not exceed 0.5 inch

water gauge, because the resistance offered by the cooling tower is comparatively small, if properly designed. A frequent arrangement with chimney cooling towers is—The body of the tower where the water is being sprayed is comparatively large, it is spread out so as to cover a comparatively large area, while the chimney has a smaller area.

Chimney towers vary in form, but are built on very much the

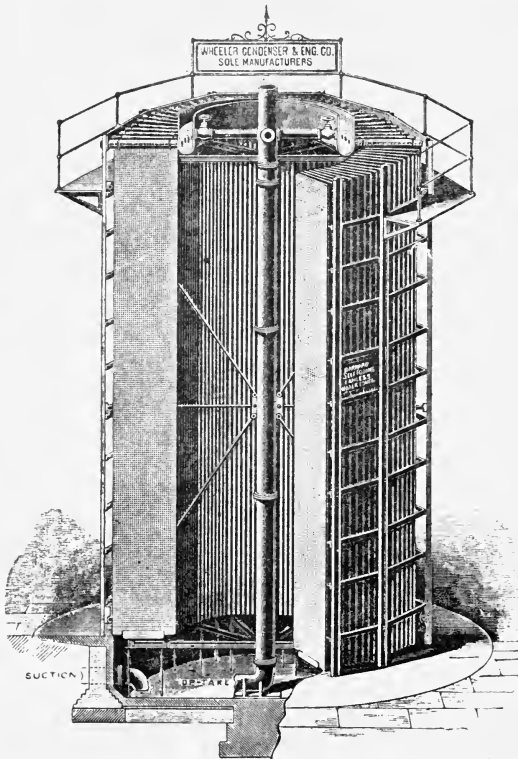

FIG. 187.—Another form of Barnard Chimney Cooling Tower. The Air passes up through the Centre and out at the Sides, the Water trickling over the Mats, which are arranged radially round the Centre.

same lines. The tower proper, as indicated above, in which the apparatus is held, that is employed to spray the water, occupies the lower part of the tower, being carried up to a sufficient height, and occupying a sufficient space to provide for treating the largest quantity of water that may be wanted to be handled, under the most severe conditions of work. Above the cooling tower proper is the

chimney, and the water to be cooled is led into the cooling tower at the base of the chimney, being broken up, and caused to trickle down to the bottom, as already explained. At the bottom of the tower are entrances for the air, and it passes up through the spaces between the apparatus employed for breaking up the water, and at the top of the cooling portion, passes into the chimney, and away to the atmosphere. Fig. 185 shows a section of a chimney cooling tower by Messrs. Balcke. Figs. 186 and 187 show Barnard chimney cooling towers.

It will be evident that the height and size of the chimney must be such that under the very worst conditions, both of working and of the outside atmosphere, the difference of pressure created between the top and bottom of the cooling tower, is sufficient to cause the necessary quantity of air to pass through the tower, to evaporate the necessary quantity of water. It should be mentioned that this is one of the difficulties that has sometimes arisen in connection with the use of cooling towers. The engineer who has been responsible for the design and fixing of the cooling tower, has not worked as he should have done, to the worst conditions he will have to meet, and consequently in muggy weather, for instance, when the outside atmosphere is comparatively light, the draught through the cooling tower has not been sufficient to cause the necessary evaporation, and the cooling water has not been sufficiently lowered in temperature, the vacuum in the condenser has gone back, and the engines have not been able to do as much work as they should have done.

## The Cooling Tower with Fan Draught

The cooling tower with fan draught is the equivalent of the boiler furnace with forced draught. The tower is constructed in the usual way, and draught is provided by one or more fans, fixed near the base of the tower, driven by any convenient source of power, an electric motor being a favourite one in electricity generating works, but a small engine, either gas, oil or steam, or a strap from any convenient running shaft will also answer the purpose. The fan draught tower is more expensive to instal, and it is necessarily more expensive to work, because of the power employed in driving the fan; but it has the great advantage that it is completely under the control of the engineer, within the limits of the capacity of the fan, and even if a given fan proves not to be sufficiently powerful to furnish the necessary draught, it is not a great matter, in the majority of cases, to remove it, and fix a larger one. Fig. 188 shows a Balcke fan-cooling tower.

## Apparatus used in Cooling Towers

The arrangements inside cooling towers vary very considerably, according to the ideas of the different inventors, but as already

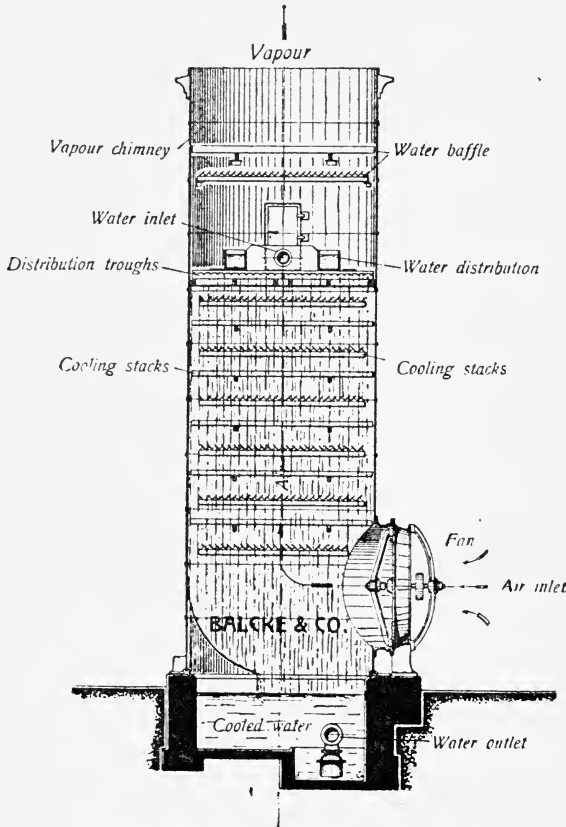

FIG. 188.—Balcke Fan-cooling Tower.

explained, all of them are intended to accomplish the same object—the thorough breaking up of the water to be cooled, into the smallest possible particles. A favourite form consists of a number of **V**-shaped channels, formed something like the gutters that are employed to carry off the rain on the outside of buildings, the gutters being placed one under the other, and the water being allowed to fall gently into the top gutter, to very gently overflow the edge of

the gutter, trickling down the outside of the laths of which the gutter is composed, from there passing on to the inside of the next gutter, gradually filling that, overflowing down the outer sides on to the next, and so on, the idea being that by overflowing on to the outside of each gutter, and trickling down as described, the water is broken up into fine drops.

In another form, a number of wooden gratings are placed one above the other, sometimes horizontally, and sometimes at a slight inclination, the water being sprayed gently on to the upper grating, passing through the holes, and overflowing the sides, trickling on to the undersides of the first grating, thence passing to the second, trickling over it, and so on to the bottom. To be of service, the holes in the gratings in this form of apparatus must be small, and if the water contains any deposit of any kind, it tends to fill up the the holes, and to reduce the ability of the gratings to break the water up into small particles.

Another form consists of iron plates, with very small holes, the water being allowed to trickle gently over the plates, and through the holes, the plates being placed one above the other, and a variation of this is a series of wire gratings placed either horizontally or nearly horizontally, the mesh of the gratings being fairly close, and the water trickling over and through them, the bars of the gratings tending to break it up.

A further modification of this, used in the Barnard cooling tower, consists of a number of galvanized iron mats, plaited, so as to present a large surface, with a number of holes in them, the mats being suspended vertically in the tower, in rows, the rows being placed under each other, as shown in Figs. 186 and 187, but with the tops of the second row opposite the space between the first row, successive rows at right angles, and so on, the water in this case trickling over the surfaces of the mats, and passing from one mat to the other, down to the bottom of the tower.

Another arrangement consists of corrugated or fluted iron plates, sometimes pierced with holes, arranged as a succession of inclined planes, leading from side to side of the tower, the upper plate, say, inclining from left to right, the second one from right to left, and so on. The water is delivered gently to the top of the upper plate, over whose surface it trickles, part of it passing through the holes, and the remainder passing to the bottom of the plate, and all of it passing on to the second inclined plate over which it trickles, part passing through it, and so on.

Another method, employed by the Worthington Pump Co., consists of a series of short hollow-glazed earthenware cylinders, similar to those employed for drain pipes, stacked in rows one above the other, and so arranged that the edges of one row are over the middle

of the next row, and so on, the water being delivered to the edges of the topmost row, and trickling down over the surfaces of the pipes, and being broken up as it passes, to the bottom of the tower. Fig. 189 shows a Worthington fan-cooling tower made on these lines.

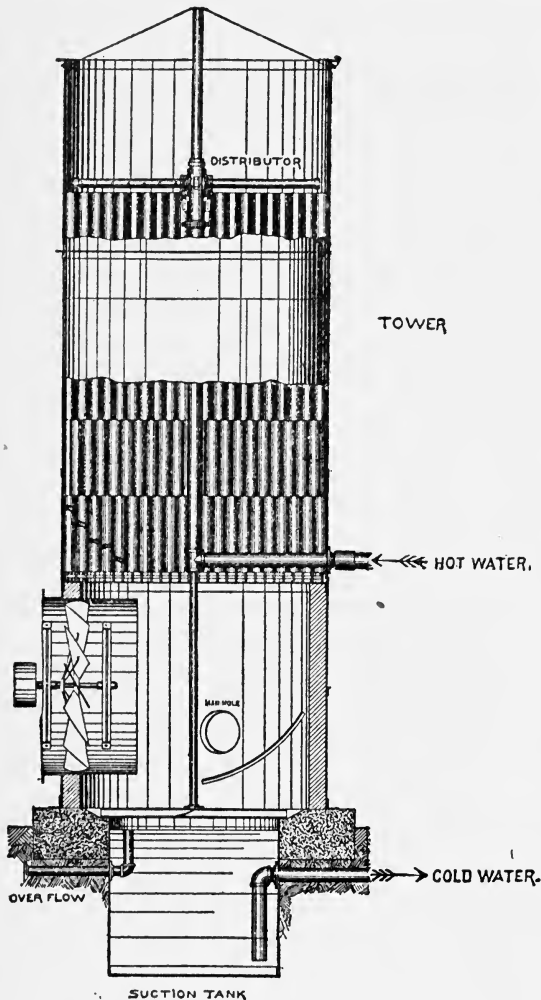

FIG. 189.—Worthington Fan-cooling Tower, showing the Earthenware Pipes used for breaking up the Water to be cooled.

### A Convex Splash Bar Cooling Tower

Messrs. Richardson, Westgarth & Co. have adopted a new form of apparatus for breaking up the water into very fine spray, in the manner described above, which they have called their convex splash bar. From experiments which they have made, they state that when a drop of water falls on to an inclined flat bar, the division of the drop into spray is comparatively slight. They say further, that they find that a drop of water falling on to a horizontal flat bar, tends to break up best, but that as the bar soon becomes wet, and holds a certain quantity of the water on its surface,

a bed or cushion is formed for the later falling water, which tends to neutralize any breaking up effect. To meet this they have designed a bar that has a convex surface, and the makers claim that



the drops of water falling on the convex surface, are broken up as much as by falling on a flat surface, on which there is no cushion, and that the convex surface prevents the cushion being formed.

The natural draught cooling towers made by this firm are about 70 feet in height, the chimney portion being about 45 feet high, the water being delivered at a height of 25 feet to the distributing troughs.

### Construction of Cooling Towers

The early cooling towers were constructed of wood, mainly, the author believes, because it was desired not to spend more money than could be avoided, in what was in those days experimental work. Now that the cooling tower has thoroughly established itself, it is still sometimes constructed of wood, but iron, steel, and even stone and brickwork are largely taking the place of wood. Wood, when exposed to the conditions ruling in a cooling tower, wet, wind, weather, and sometimes if the tower is out of use for a time to drying, does not last, unless the wood itself is carefully chosen, has been well seasoned, and is of a special quality that will withstand all these changes. Further, wood, if the tower is to be made sufficiently strong, to continue in work for the time the works are running, must occupy a considerable space. That is to say, in order to provide the same strength as with iron, steel, or even stone or brick, the masses of wood employed must be very much larger, very much more clumsy, and must occupy considerably larger space. In out-of-the-way places, where appearance is not of importance, and where the works are not likely to run for a considerable time, as in the case of a mine that may be worked out at any moment, the wood cooling tower is all that can be desired, and is probably the most economical. But for the cases of electricity-generating stations and other works, where cooling of the condensing or other water is carried out by the aid of towers, and where appearance is of importance, and, still more, where space is of importance, stone or brick towers, and still more steel or iron towers are very much more economical and more substantial.

Cooling towers are made sometimes rectangular in section, sometimes circular, sometimes of other forms. The circular section, as in every other case, is probably the most convenient, and the most efficient, though it is very difficult to construct when the tower is of wood, hence the fancy for rectangular sections in wooden towers. When the tower is of iron or steel, it is built up very much in the same manner as the shell of a Lancashire boiler, or an iron or steel chimney, of rings made of one or more iron or steel plates, riveted together, the successive rings being riveted to each other, the lowest

rings being arranged with a flange to bolt to the foundations, and the whole being fixed very much on the lines of a very large chimney. An aperture is cut in one portion of the side of the tower, in which the fan is placed.

When the tower is constructed of stone or brick, it is built very much on the lines of a large low chimney. In some cases the lower portion of the tower is built of stone or brick, and the upper portion of iron or steel.

The different portions of the tower must be stayed, in the usual way, and provision must be made for fixing the different cooling arrangements inside, and for the pipes for delivering the water, etc.

A somewhat favourite form of cooling tower with wood, and sometimes with iron structures, is of rectangular section, with a vertical partition dividing the tower into two portions, and with two separate fans or other provisions for furnishing the necessary draught. This arrangement allows for heavy loads, or for a lowered efficiency of the tower under the atmospheric conditions that have been named. Thus one half of the tower can be employed under ordinary working conditions, and both halves under special conditions, the two halves being used alternately to keep them in working order. It will be noticed that in all arrangements of cooling towers where vertical draught rules, the air current and the water current are in opposite directions. This, as already explained, is the rule in all cases where it is possible, where heat is to be abstracted from any moving body. The coldest air entering the tower at the bottom meets the coldest water that has been subjected to the cooling effect of the evaporation that has been taking place during its descent through the tower, while the hottest water meets the warmest air as it enters the tower. It will be understood that, as with the cooling ponds, a certain quantity of water is lost by evaporation, and is carried off by the draught and delivered to the outside atmosphere. It has been estimated that with properly proportioned cooling towers, the loss of water varies from 1.2 to 2.5 gallons per indicated H.P. per hour, according to the force of draught employed. It will be understood again that the quantity of water evaporated, and therefore the cooling effect produced, varies directly with the velocity of the air current passing through the tower, that is to say, directly as the draught. Each cubic foot of air properly applied absorbs a certain quantity of watery vapour, and therefore the higher the velocity of the air, the greater is the absorption of vapour. This, however, only applies up to a certain point, though the actual limit has not yet been determined.

# INDEX

## A

- Absolute pressure, definition of, 22  
Absolute temperature on Centigrade scale, 5  
Absolute temperature on Fahrenheit scale, 5  
Absolute unit of heat, 14  
Absorber flange seam boiler flues, Adamson, 63  
Absorption of heat, 10  
Absorption of water vapour by air, 25  
Action of steam in pressure turbine, 292  
Action of steam on water in pockets, 278  
Action steam turbine, 289  
Actinic rays, 3  
Adamson absorber flange seam boiler flues, 63  
Adamson joint, boiler flues, 63  
Adamson, Daniel, triple-expansion mill engine, 240  
Adaptability of turbines for exhaust steam, 323  
Adiabatic expansion of steam, 290  
Adjustable nozzle for steam jet draught, 148  
Admission of steam to intermediate sections of turbine, 295  
Advantages claimed for corrugated boiler furnaces, 65  
Advantages claimed for Fraser's condenser, 336  
Advantages claimed for steam jets, 147  
Advantages of circular chimneys, 137  
Advantages of ejector condenser, 344  
Advantages of induced draught, 143  
Advantages Lancs. boiler over water-tube, 78  
Advantages of mechanical stokers, 115  
Advantages of multitubular boilers, 71  
Advantages of parallel slide stop valve, 257  
Advantages of superheated steam in turbines, 328  
Advantage of water-tube boilers with high pressures, 79  
Advantages of vacuum augments, 347  
A.E.G. turbine, construction of, 316  
A.E.G. turbine, course of steam in, 316  
Air, composition of, 25  
Air and absorption of water vapour, 25  
Air and the economizer chamber, 163  
Air and heat conduction, 10  
Air and heat absorption, 11  
Air at various temperatures, volume and weight of, 26  
Air cells in thermal insulators, 13  
Air cylinder in Willans engine, 233  
Air, effect of, in surface condenser, 332  
Air, expansion and contraction with temperature, 25  
Air for the furnace, methods of providing, 127  
Air heating with forced draught, 139  
Air heating and induced draught, 143  
Air leakage and boiler brickwork, 69  
Air leakage in boiler flues, 143  
Air leakage and induced draught, 143  
Air, power required to move, 147  
Air, properties of, 25  
Air pumps, bucket, 366  
Air pump capacity for condenser, Richard Allen, 356  
Air pump capacity for condenser, Prof. Weighton, 361  
Air pumps, dry, two stage, 365  
Air pumps for condenser, 365  
Air pump, Edwards, operation of, 366  
Air pump with Fraser's condenser, 336  
Air pump for jet condenser, 340  
Air pump for surface condenser, 331  
Air required for combustion of fuel, 130  
Air required with forced draught, 141  
Air, saturation by water vapour, 27  
Air, specific heat of, 29  
Air supply with Fraser's condenser, 336  
Air, temperature outside and chimney draught, 134  
Air and water heating economisers, arrangement of, 162  
Air, weight of, 18  
Allen's high-speed engines, construction of, 229

- Allen, Richard, condenser experiments, 352
- Alphonse Custodis chimneys, 138
- Alternating current generators, use of stop valve in driving, 243
- Analysis, flue gas apparatus, Orsat, 212
- Analysis of water and water softening, 182
- Anderson steam trap, construction of, 286
- Angle of incidence, 4
- Angle of refraction, 4
- Angle stop valves, 255
- Anthracite coals, properties of, 42
- Apparatus for burning coal dust, 110
- Apparatus for burning liquid fuel, 49, 111
- Apparatus, Davis-Perrett, sizes of, 199
- Apparatus, Orsat, for flue gas testing, 212
- Apparatus for removing oil, Harris-Anderson, 198
- Apparatus, special, for removing oil, 197
- Apparatus used in cooling towers, 376
- Apparatus, water safety, 155
- Approximate analysis of fuel, 43
- Archbutt-Deely apparatus, carbonating water in, 184
- Archbutt-Deely apparatus, mud precipitate, 184
- Archbutt-Deely apparatus, operation of, 184
- Archbutt-Deely apparatus, special feature of, 183
- Archbutt-Deely water softener, 183
- Area grate of furnace required, 132
- Arrangement of air and water heating economizers, 167
- Arrangement of central condensing stations, 348
- Arrangement of cranks with ram pumps, 170
- Arrangement of cranks, Willans engine, 233
- Arrangement of Curtis turbine, 311
- Arrangement of cylinders, quadruple-expansion engines, 227
- Arrangement of cylinders in triple-expansion engines, 226
- Arrangement of cylinders in Willans engine, 232
- Arrangement of fan with induced draught, 141
- Arrangement of Holden liquid fuel apparatus, 112
- Arrangement of rings of boiler shells, 62
- Arrangement of steam pipes, 278
- Arrangement of steam and water pipes in ejector condenser, 344
- Arrangement of triple-expansion engines, 226
- Arrangement of tubes, Thornycroft-Schultz boiler, 101
- Arrangement of worm gearing, 265
- Ash, effect of, on calorific value, 41
- Ashpit in Lancs. boilers, 59
- Ashpits in water-tube boilers, 82, 107
- Asphalt, 47
- Atlas boiler, course of hot gases, 94
- Atlas boiler, drums in, 93
- Atlas boiler, feed water, 93
- Atlas boiler, headers in, 93
- Atlas boiler, superheating, 94
- Atlas boiler, water purifying apparatus, 95
- Atlas water-tube boiler, 93
- Atmosphere, composition of, 18
- Atmosphere, gases in, 18
- Atmosphere, variation in pressure of, 19
- Atmosphere and water vapour, 18
- Atmospheric line on indicator cards, 272
- Atmospheric pressure and mercurial barometer, 18
- Atmospheric pressure, specified heat of superheated steam at, 36
- Atmospheric pressure, standard, 18
- Atmospheric relief valve, 155
- Augmenter, Parsons, vacuum, 347
- Automatic CO<sub>2</sub> recorder, Sarco, 208
- Automatic damper regulators, 149
- Auto stoker, construction of, 122
- Auto stoker, fire bars in, 123
- Axle of Brush-Parsons turbine, 301

## B

- Babcock boiler, construction of, 82
- Babcock boiler, course of hot gases in, 83
- Babcock boiler, headers in, 83
- Babcock boiler, steam drums in, 83
- Babcock boiler, superheater, 83
- Babcock chain-grate stoker, construction of, 125
- Babcock marine boiler, 83
- Babcock superheater, 200
- Babcock water-tube boiler, 82
- Back pressure, mean in cylinder, 218
- Bagasse, calorific value of, 45
- Bailey's reducing valve, 259
- Balanced slide valves, 248
- Balancing discs in steam turbine, 295
- Balcke's chimney cooling tower, 373
- Balcke's fan cooling tower, 376
- Balcke's jet condenser, 340
- Barnard chimney cooling tower, 373
- Barometer indications and water vapour in atmosphere, 19
- Barometer, mercurial, 18
- Barometric condenser, 344
- Barometric condenser, Bulkley, 345

- Barometer condenser, cooling water for, 346
- Barometric condenser, course of steam in, 345
- Barometric condenser, operation of, 344
- Barometric condenser, pump for, 346
- Bars, furnace, special forms of, 108
- Bearings of Brush-Parsons turbine, 301
- Bearings of Curtis turbine, 311
- Bearings of Hamilton Holzwarth turbine, 321
- Bearings of Parsons turbine, construction of, 295
- Bearings of Zoelly turbine, 319
- Beds of streams, surface condensers for, 336
- Belliss engines, construction of, 229
- Belt, double, formula for, 264
- Belt drive, efficiency of, 265
- Belt driving and crank shaft, 262
- Belt driving, pulleys for, 262
- Belt, driving side of, 263
- Belt, how power is transmitted by, 262
- Belt pulleys, heating of, 263
- Belt, size of, formula for, 263
- Belt, slipping of, 263
- Belt, tight side and loose side, 263
- Bennis mechanical stoker, 122
- Bi-carbonates, temperature at, when splitting up, 33
- Bituminous coals, composition of, 42
- Bituminous coals, properties of, 41
- Blades of Willans turbine, construction of, 293
- Blast furnace gas, calorific value of, 51
- Blast furnace gas, composition of, 51
- Blast furnace gas, production of, 50
- Blast furnace gas, use of, 50
- Board of Trade formula for boiler furnaces, 65
- Board of Trade, powers of, 68
- Bodies in mechanical suspension in water and boiling point, 21
- Boiler, Babcock, course of hot gases, 83
- Boiler, Babcock, superheater, 83
- Boilers and brickwork, 68
- Boiler brickwork and air leakage, 69
- Boiler brickwork, McLeod and Henry, 69
- Boiler for burning refuse, Galloway, 70
- Boiler chimneys, construction of, 137
- Boiler chimneys, forms of, 137
- Boiler cleaners, construction of, 150
- Boiler cleaners, reason for, 150
- Boilers, Cornish, setting, 68
- Boiler, dry back, 72
- Boilers, electrolytic action, 181
- Boiler feed and exhaust from turbines, 329
- Boiler feed pumps, electrically driven, 172
- Boiler feed and scale forming substances' 181
- Boiler feed, use of cooling water for, 333
- Boiler fittings, enumeration of, 151
- Boiler flues, absorber flange seam, Adamson, 63
- Boiler flues, Adamson joint, 63
- Boiler flues, air leakage with, 143
- Boiler flues, construction of, 63
- Boiler flues, Cornish, 63
- Boiler flues, corrugated, 64
- Boiler flue dampers, 148
- Boiler flues, joints of, 63
- Boiler flue joint, Davey-Paxman, 64
- Boiler flues, Lancs., 63
- Boiler furnace cambered, John Brown, 65
- Boiler furnace, colliery refuse, Meldrum, 70
- Boiler furnaces corrugated, 64
- Boiler furnaces corrugated, advantages claimed for, 65
- Boiler furnaces, doors of, 108
- Boiler furnaces, effect of water vapour in air, 27
- Boiler furnaces, formula, Board of Trade, 65
- Boiler furnace formula, British Corporation, 65
- Boiler furnace, formula, Bureau Veritas, 65
- Boiler furnaces formula, Lloyd's, 65
- Boiler furnace improved, John Brown, 65
- Boiler furnace, methods of providing air for, 127
- Boiler furnace, Morrison suspension, 65
- Boiler furnace, pressure of air creating draught, 28
- Boiler furnaces, sizes of, with working pressures, 67
- Boiler furnace, steam jets, arrangement of, 147
- Boiler furnaces, tests of, 65
- Boilers, heating feed water for, 156
- Boilers, horse power of, discussed, 132
- Boilers, Lancs., setting, 68
- Boiler, locomotive, 72
- Boiler, locomotive, construction of, 73
- Boiler, marine, 72
- Boiler, marine, Babcock, 83
- Boiler, motor-wagon, White, 106
- Boiler plate punching, 61
- Boiler, Robb-Mumford, construction of, 76
- Boiler shells, building up, 61
- Boiler shells, butt joints, 61
- Boiler shells, drilling, 61
- Boiler shells, joints in, 61
- Boiler shells, lap joints, 61
- Boiler shells, riveting, 62
- Boiler, Stirling drums of, 86

- Boiler, Stirling, superheater, 86  
 Boiler, Thornycroft-Marshall, 100  
 Boiler, Thornycroft-Schultz, 100  
 Boiler-tube cleaners, turbine, 151  
 Boiler-tube cleaner, Wynland, 150  
 Boiler-tube cleaning by steam jet, 151  
 Boilers, vertical, small, 104  
 Boiler water gauge, construction of, 151  
 Boiler, water-tube, Atlas, [93]  
 Boiler, water-tube, Babcock, 82  
 Boiler, water-tube, brickwork, 78  
 Boilers, water-tube, circulation, 81  
 Boiler, water-tube, Climax, 98  
 Boilers, water-tube, convenience for transporting, 81  
 Boiler, water-tube, Davey-Paxman, 91  
 Boilers, water-tube, furnace of, 82  
 Boiler, water-tube, Galloway, 93  
 Boilers, water-tube, with horizontal tubes, 90  
 Boiler, water-tube, Marshall, 91  
 Boiler, water-tube, Nesdrum, 87  
 Boiler, water-tube, Stirling, 84  
 Boiler, water-tube, Taylor, 104  
 Boiler, water-tube, Thornycroft, 99  
 Boiler, water-tube, Wood, 92  
 Boiler, water-tube, Woodeson, 88  
 Boiler, wet back, 74  
 Boiler, working, effect of scale upon, 181  
 Boiler work, pressure required for, 130  
 Boiling, operation of, 19  
 Boiling-point on Centigrade scale, 4  
 Boiling-point and effect of pressure on surface of liquid, 19  
 Boiling-point on Fahrenheit pressure, 4  
 Boiling-point on Reaumur pressure, 4  
 Boiling-point, standard level for, 18  
 Boiling-point, standard pressure for, 18  
 Boiling-point, variation of, 18  
 Boiling-point of water and bodies in mechanical suspension, 21  
 Boiling-point of water and dissolved substances, 21  
 Boiling-point of water at various altitudes, 20  
 Boiling temperature, increase of, with pressure, 21  
 Brake horse-power, 219  
 Brake horse-power, measurement of, 220  
 Brass and iron, expansion of, 6  
 Brasses in compression, Willans engine, 233  
 Brickwork with water-tube boilers, 78  
 Bridge in furnace grates, 107  
 Bristol's thermo-electric pyrometer, 9  
 British Corporation, explanation of, 68  
 British Corporation formula boiler furnace, 65  
 British thermal unit, definition of, 13  
 British thermal unit and the horse-power, 15  
 Brooke's steam trap, construction of, 281  
 Brooke's steam trap, operation of, 281  
 Brotherhood engines, construction of, 229  
 Browett engines, construction of, 229  
 Brown coals, composition of, 41  
 Brown, John, cambered boiler furnace, 65  
 Brown, John, improved boiler furnace, 65  
 Brunn-Lowener water softener, construction of, 187  
 Brush-Parsons turbine, 300  
 Brush-Parsons turbine bearings, 301  
 Brush-Parsons turbine, control of steam to, 301  
 Bucket air pumps, 366  
 Bucket in Edwards air pump, 366  
 Buckets of steam turbines, forms of, 322  
 Building up boiler shells, 61  
 Bulkley barometric condenser, 345  
 Bumsted engine, double acting, 237  
 Bumsted engine, forms of, 236  
 Bumsted engine, lubrication of, 236  
 Bumsted engine, single acting, 236  
 Bumsted high speed engine, 236  
 Bureau Veritas formula, boiler furnace, 65  
 Bureau Veritas, powers of, 68  
 Burning liquid fuel, apparatus, 49, 111  
 Burning refuse, boiler, Galloway, 70  
 Burning town's refuse, 113  
 Burning town's refuse, draught with, 114  
 Butt joints boiler shells, 61
- C
- Calorie, 14  
 Calorific power, explanation of, 38  
 Colorific value of bagasse, 45  
 Colorific value of blast furnace gas, 51  
 Colorific value of coke-oven gas, 51  
 Colorific value of corn, 46  
 Colorific value of cotton, 46  
 Colorific value, effect of nitrogen on, 41  
 Colorific value, explanation of, 38  
 Colorific value formula, Dulong, 39  
 Colorific value of gas tar, 48  
 Colorific value of natural gas, 52  
 Colorific value of producer gas, 50  
 Colorific value of spent tan, 45  
 Colorific value of straw, 45  
 Colorific value of town's refuse, 113  
 Colorific value of wood, 45  
 Calorimeter, Thomson's, 44  
 Calorimeters, description of, 44  
 Calorimetry, explanation of, 44  
 Cannel coal, composition of, 41  
 Capacity of air for water vapour, law of, 25

- Carbon and oxygen, combustion, 37  
 Carbonates and bi-carbonates in water, 33  
 Carbonate of calcium in water, 33  
 Carbonate of magnesium in water, 33  
 Carbonating water in Archbutt-Deely apparatus, 184  
 Carbonic acid and heat absorption, 11  
 Carbonic acid, heat liberated in forming, 38  
 Carbonic acid and water, 33  
 Carbonic oxide and heat absorption, 11  
 Carbonic oxide, heat liberated in formation of, 38  
 Care of economizers in frosty weather, 162  
 Carnot's law of heat engines, 36  
 Carter's economizer, construction of, 160  
 Cause of waste in domestic fire grate, 54  
 Celsius scale, 4  
 Centigrade scale, divisions of, 4  
 Centigrade scale, limits of, 4  
 Central condensing plant with cooling tower, 350  
 Central condensing stations, 348  
 Central condensing stations, operation of, 349  
 Central Engineering Co.'s evaporator, 205  
 Central pressure stop valve, Hopkinson, 257  
 Central pressure stop valve, operation of, 257  
 Central valve engine, Willans, 232  
 Centrifugal fan, construction of, 146  
 Centrifugal fan, pressure in, how produced, 146  
 Centrifugal pump for condenser, 363  
 Chain-grate mechanical stokers, 124  
 Chart of Simmance recorder, 211  
 Chemical action in combustion, 37  
 Chemical rays, 3  
 Chimney cooling tower, Balcke, 373  
 Chimney cooling tower, Barnard, 373  
 Chimney cooling towers, forms of, 374  
 Chimney cooling towers, height of, 375  
 Chimney cooling towers, operation of, 372  
 Chimney cooling tower, pressure in, 373  
 Chimney cooling towers, sizes of, 375  
 Chimney draught, explanation of, 127  
 Chimney draught and motive column, 128  
 Chimney draught, seasons, effect of, 135  
 Chimney draught and temperature of outside air, 134  
 Chimney gases, temperature of, with forced draught, 140  
 Chimney, height of, and intensity of draught, 137  
 Chimney pressure, with different temperatures outside, 134  
 Chimney, temperature of hot gases in, 129  
 Chimney, testing flue gases in, 205  
 Chimneys, Alphonse Custodis, 138  
 Chimneys, boiler, construction of, 137  
 Chimneys, boiler, forms of, 137  
 Chimneys, circular, advantages of, 137  
 Chimneys, circular and other forms, 137  
 Chimneys, effective area of, 135  
 Chimneys, foundations of, 138  
 Chimneys, height of, 132  
 Chimneys, height of, Kent's table for, 135  
 Chimneys, loss of energy in, 131  
 Chimneys and radial bricks, 138  
 Chimneys, requirements of, 131  
 Chimneys, sectional area of, 132  
 Chimneys, standard for, Prof. Thurston, 132  
 Chimneys, steel, construction of, 138  
 Chimneys and water tanks, 138  
 Chlorides and water, 33  
 Circular chimneys, advantages of, 137  
 Circular and other forms of chimney, proportion between, 137  
 Circulating pump for surface condenser, 331  
 Circulating pump, variation of speed for condenser, 363  
 Circulating water for condensers, cooling, 367  
 Circulating water, velocity of, Prof. Weighton, 362  
 Circulation in boilers by convection currents, 54  
 Circulation in boilers, explanation of, 54  
 Circulation in boilers, importance of, 54  
 Circulation of water, Climax boiler, 99  
 Circulation in water-tube boilers, 81  
 Classes of steam turbine, 288  
 Cleaning deposit from economizer tubes, 159  
 Cleaning of filter in Reiser water softener, 186  
 Clearance in Rateau turbine, 316  
 Clearance in Zoelly turbine, 319  
 Climax boiler, construction of, 98  
 Climax boiler, course of hot gases, 99  
 Climax boiler, feed water heater, 99  
 Climax boiler, steam drum, 99  
 Climax boiler, water circulation, 99  
 Climax boiler, water tubes of, 98  
 Climax water-tube boiler, 79, 98  
 Closed ashpit system of forced draught, 139  
 Closed ashpit system, objections to, 139  
 Closed fire room system of forced draught, 139  
 Closed stoke-hole system of forced draught, 139  
 Clouds, formation of, 32  
 Coal, description of, 39  
 Coals, differences between, 42  
 Coal dust burning apparatus, 110

- Coal dust burning apparatus, Cyclone, 111  
 Coal dust burning apparatus, Schwartzkopf, 111  
 Coal dust furnace, Meldrum, 110  
 Coal, forms of, 40  
 Coals, gradation of, 41  
 Coal saved by condensing, Richard Allen, 355  
 Coals, volatile matter, 42  
 Cochrane vacuum, oil separator, 195  
 Coke oven gas, calorific value of, 51  
 Coke oven gas, production of, 51  
 Coker mechanical stokers, rams of, 119  
 Coker mechanical stokers, shovels of, 119  
 Coker stoker, Meldrum, 119  
 Coking mechanical stokers, 117  
 Colliery refuse destructor, Meldrum, 114  
 Colliery refuse, furnace, Meldrum's, 70  
 Column of air above the earth, weight of, 18  
 Combination of exhaust and live steam, 325  
 Combined boiler, construction of, 76  
 Combined condenser and pump plant, Wheeler, 337  
 Combined Cornish and multitubular boiler, 76  
 Combined stop and safety valve, 156  
 Combustion, chemical action, 37  
 Combustion, combination of carbon and oxygen, 37  
 Combustion in domestic fire grate, 53  
 Combustion fuel in furnace, 37  
 Combustion, volume of gases produced by, 130  
 Comparison of mean pressures with varying cut-offs, 215  
 Composition of bituminous coals, 41  
 Composition of blast furnace gas, 51  
 Composition of brown coals, 41  
 Composition of cannel coal, 41  
 Composition of gas tar, 48  
 Composition of natural gas, 52  
 Composition of peat, 40  
 Composition of petroleum, 46  
 Composition of producer gas, 50  
 Composition of semi-bituminous coals, 41  
 Composition of wood, 44  
 Compound condensing engine, tandem horizontal, 224  
 Compound Cornish boiler, Fraser and Chalmers, 76  
 Compound engines, arrangement of, Willans engine, 234  
 Compound engine, course of steam with, 221  
 Compound engines described, 221  
 Compound engines, horizontal, arrangement of, 239  
 Compound engine, proportion of cylinders in, 221  
 Compound engine, tandem, horizontal, 223  
 Compound pressure turbines, construction of, 292  
 Compound vertical engines, arrangement of, 239  
 Compound vertical engine, unenclosed, 225  
 Compounding in pressure turbines, 292  
 Compressed air, and heat in Willans engine, 234  
 Compressed air machinery, engines for driving, 239  
 Compressing air, work in Willans engine, 234  
 Condensation in cylinder, with expansive working, 215  
 Condensation of water vapour, 34  
 Condensed water for feed, objection to, 169  
 Condenser, air pump capacity, Richard Allen, 356  
 Condenser, barometric, cooling water for, 346  
 Condenser, barometric, course of steam in, 345  
 Condenser, barometric, course of water in, 345  
 Condenser, barometric, operation of, 344  
 Condenser, centrifugal pump for, 363  
 Condensers, circulating water for, cooling, 367  
 Condenser, Contraflo, 338  
 Condenser, cooling surface, and I.H.P., 352  
 Condenser, cooling surface, Richard Allen, 356  
 Condenser, counter-current, jet, 340  
 Condenser, dry air pump for, 365  
 Condenser efficiency, Prof. Weighton, 361  
 Condenser, ejector, operation of, 343  
 Condenser employed by Prof. Weighton, 360  
 Condenser experiments, Richard Allen, 352  
 Condensers, experiments on, Prof. Weighton, 360  
 Condenser, evaporative, Fraser, 335  
 Condensers fixed in Lancs. mill engines, 241  
 Condenser, jet, air pump for, 340  
 Condenser, jet, Balcke, 340  
 Condenser, jet, counter current, 340  
 Condenser, jet, Mirrlees-Watson, 341  
 Condenser, jet, parallel current 340  
 Condenser, jet, pumps for, 340  
 Condenser, jet, versus surface, 341



- Condenser, jet, Worthington, velocity of steam in, 343  
 Condenser, operation of, 330  
 Condenser, plunger pumps for, 363  
 Condensers, pumps for, 363  
 Condenser, pump and electric motor, 363  
 Condenser and pump plant combined, Wheeler, 337  
 Condenser with solid wooden cores, 360  
 Condensers, surface, for the beds of streams, 338  
 Condenser, surface, construction of, 331  
 Condenser, surface, evaporative, construction of, 334  
 Condensers, surface, open tank, 338  
 Condenser, surface, Wheeler, 336  
 Condenser, use of, 330  
 Condenser for use with De Laval turbine, 309  
 Condenser, velocity of circulating water in, Prof. Weighton, 362  
 Condenser, velocity of cooling water in, 352  
 Condensing, coal saved by, Richard Allen, 355  
 Condensing cooling water, quantity of, 349  
 Condensing, cooling water required for, Prof. Weighton, 361  
 Condensing, economy of with different steam pressures, 367  
 Condensing engine, cross-compound, horizontal, 224  
 Condensing plant, central, with cooling tower, 350  
 Condensing plant, power absorbed by, 367  
 Condensing plant, steam consumption, Richard Allen, 355  
 Condensing stations, central, arrangement of, 348  
 Condensing stations, central, operation of, 349  
 Condensing, triple-expansion mill engine horizontal, 240  
 Condensing and turbines, 327  
 Conditions of matter explained, 17  
 Conduction of heat, 9  
 Conductive powers of metal, 11  
 Conductivity, thermal, definition of, 11  
 Conductivity thermal, of finely divided substances, 12  
 Connection of trap to steam service, 280  
 Constant ratio of refraction, 3  
 Consumption of steam, De Laval turbine, 302  
 Consumption, steam, with different vacua, Richard Allen, 353, 354  
 Consumption of steam in vacuum aug-  
 menter, 348  
 Contraction and expansion of steam  
 pipes, 279  
 Contraflo condenser, course of cooling  
 water in, 339  
 Contraflo condenser, course of steam in,  
 339  
 Contraflo condenser, operation of, 339  
 Contraflo condenser, vapour distribution  
 chambers in, 339  
 Control of air by flue dampers, 148  
 Control of steam for Brush-Parsons tur-  
 bine, 308  
 Control of steam supply by governor, 243  
 Control of steam supply by stop valve, 243  
 Convection currents, 9  
 Convection currents in boilers, 54  
 Convenience water-tube boilers for trans-  
 porting, 81  
 Conversion of potential into kinetic  
 energy, 289  
 Convex splash bars for cooling towers,  
 378  
 Cooling circulating water for condensers,  
 367  
 Cooling the cooling water, 333  
 Cooling effect of evaporation of water,  
 335  
 Cooling of furnace bars by steam jets, 147  
 Cooling ponds, evaporation from, 369  
 Cooling ponds and Lancs. cotton mills,  
 368  
 Cooling ponds, louvre boards for, 370  
 Cooling ponds with nozzles, 369  
 Cooling surface in condenser per I.H.P.,  
 352  
 Cooling surface in condenser, Richard  
 Allen, 356  
 Cooling towers, 370  
 Cooling towers, apparatus used in, 376  
 Cooling tower and central condensing  
 plant, 350  
 Cooling tower, chimney, Balcke, 373  
 Cooling tower, chimney, Barnard, 373  
 Cooling tower, chimney, height of, 375  
 Cooling tower, chimney, size of, 375  
 Cooling towers, construction of, 379  
 Cooling towers, convex splash bars for,  
 378  
 Cooling towers, corrugated iron plates  
 in, 377  
 Cooling towers, course of air in, 380  
 Cooling towers, course of water in, 380  
 Cooling towers, duplicate, 380  
 Cooling tower with fan draught, 375  
 Cooling towers, forms of, 379  
 Cooling towers, galvanized iron mats in,  
 377  
 Cooling towers, iron for, 379  
 Cooling towers, iron plates in, 377  
 Cooling tower and jet condenser, 340

- Cooling towers, loss of water in, 380  
 Cooling towers, operation of, 371  
 Cooling towers without vertical draught, protection of, 371  
 Cooling towers, wood for, 379  
 Cooling towers, wooden gratings in, 377  
 Cooling tower, Worthington Co., 377  
 Cooling water for barometric condenser, 346  
 Cooling water for condensing, quantity of, 349  
 Cooling water, heat absorbed by, 333  
 Cooling water with high vacua, 351  
 Cooling water, limiting temperature of, 332  
 Cooling water required with condensers, formula for, 351  
 Cooling water required for condensing, Prof. Weighton, 361  
 Cooling water required with different vacua, Richard Allen, 356  
 Cooling water required and initial temperature, 351  
 Cooling water velocity in condenser, 352  
 CO<sub>2</sub> recorder, Sarco, 208  
 CO<sub>2</sub> recorder, Simmance, 210  
 Cork, properties of, 13  
 Corliss valve, 242  
 Corliss valve, description of, 251  
 Corliss valve and eccentric rod, 252  
 Corliss valve, operation of, 251  
 Corliss valve, wrist plate of, 252  
 Corn, calorific value of, 46  
 Cornish boilers, construction of, 60  
 Cornish boilers, description of, 55  
 Cornish boilers, ends of, 62  
 Cornish boilers, external furnaces, 69  
 Cornish boilers, firing, 69  
 Cornish boiler flues, 56, 63  
 Cornish boilers, furnace grates, 107  
 Cornish boilers, hot gases, passage of, 56  
 Cornish boilers, setting, 68  
 Cornish boilers, sizes of, 62  
 Cornish boilers, steam space, 58  
 Cornish boilers, water in, 58  
 Cornish and multitubular boiler, 76  
 Cornish pumps, driving, 260  
 Cornish pumping engines, 213  
 Cornish valve, 242  
 Cornish valves, description of, 250  
 Cornish valve, operation of, 251  
 Cornish *versus* Lancs. boiler, 60  
 Corrugated boiler flues, 64  
 Corrugated boiler furnaces, 64  
 Corrugated boiler furnaces, advantages claimed for, 65  
 Corrugated iron plates in cooling towers, 377  
 Corrugated tube, Wainwright, 166  
 Cost of circulating water, Prof. Weighton, 363  
 Cost of producing forced draught, 141  
 Cost of water for condensing, 368  
 Cotton, calorific value of, 46  
 Counter-current jet condensers, 340  
 Cranks, arrangement of, Willans engine, 233  
 Crank, construction of, 260  
 Crank, dead points of, 261  
 Cranks and double-cylinder engines, 261  
 Crank, length of radius of, 261  
 Crank, operation of, 261  
 Crank shaft and belt driving, 262  
 Crank shaft and direct driving, 262  
 Crank shaft, governors on end of, 269  
 Crank shaft and piston rod, 260  
 Crank shaft and rope driving, 262  
 Crank shaft, source of power, 261  
 Crank shaft, use of, 260  
 Crank shaft, steam valves worked from, 262  
 Crank shaft works eccentrics, 262  
 Cranks, and three-cylinder engines, 261  
 Critical speed of De Laval turbine 303  
 Critical temperature of steam, 23  
 Critical temperature of water with injector, 178  
 Criton softener, measurements of reagents in, 184  
 Criton water softener, construction of, 184  
 Criton water softener, filter in, 185  
 Criton water softener, operation of, 185  
 Criton water softener, reagents used in, 184  
 Criton water softener, settling tank, 185  
 Crompton's thermo-electric pyrometer, 8  
 Crosby steam-engine indicator, 270  
 Cross compound condensing engine, horizontal, 224  
 Curtis turbine, arrangement of, 311  
 Curtis turbine, bearings of, 311  
 Curtis turbine, construction of, 309  
 Curtis turbine, course of steam in, 310  
 Curtis turbine, electric controller with, 311  
 Curtis turbine, form of, 311  
 Curtis turbine, governor of, 311  
 Curtis turbine, lubrication of, 311  
 Curtis turbine, separate stages in, 309  
 Curtis turbo generator, test of, 313  
 Curved surfaces, reflection by, 3  
 Cut off with steam engines, 214  
 Cyclone coal dust burning apparatus, 111  
 Cylinder, air, Willans engine, 233  
 Cylinders, arrangement of triple-expansion, Willans, 234  
 Cylinders of compound engines, Willans engine, 234

- Cylinder condensation with expansive working, 215  
 Cylinder condensation, methods of curing, 217  
 Cylinders, proportion of, in triple-expansion engines, 226  
 Cylinders, steam, warming, on starting up, 243  
 Cylinders in triple-expansion engines, 226  
 Cylinder walls, temperature with expansive working, 217
- D
- Dampers, boiler flue, 148  
 Damper regulators, automatic, 149  
 Damper regulator, Lagonda, 149  
 Damper regulator, Locke's, 150  
 "Daring" type boiler, construction of, 101  
 "Daring" type boiler, course of hot gases in, 102  
 "Daring" type boiler, drums in, 102  
 "Daring" type Thornycroft-Schultz boiler, 101  
 Davey-Paxman boilers, headers in, 91  
 Davey-Paxman boiler, mud drum, 91  
 Davey-Paxman joint, boiler flues, 64  
 Davey-Paxman multitubular boiler, 72  
 Davey-Paxman's water-tube boiler, 91  
 Davies and Metcalfe's injector, 176  
 Davis-Perrett apparatus, sizes of, 199  
 Davis-Perrett's electrical emulsifier, 198  
 Dead points of a crank, 261  
 Dead-weight safety valve, 154  
 Decreased pressure, increase of latent heat, 23  
 Definition of absolute pressure, 22  
 Definition of British thermal unit, 13  
 Definition of gauge pressure, 22  
 Definition of specific heat, 13  
 Degree of hardness, explanation of, 180  
 Degrees of humidity of air, 23  
 Degree of superheat, 200  
 De Laval turbine, condenser for use with, 309  
 De Laval turbine, construction of, 301  
 De Laval turbine, consumption of steam, 302  
 De Laval turbine, critical speed, 303  
 De Laval turbine disc, velocity of steam impinging on, 302  
 De Laval turbine, expansion of steam in, 301  
 De Laval turbine, flexible shaft in, 303  
 De Laval turbine, gearing of, 305  
 De Laval turbine, government of, 303  
 De Laval turbine, nozzles in, 301  
 De Laval turbine pumps, tests of, 303  
 De Laval turbine, settling of the wheel, 303  
 De Laval turbine, speeds of, 305  
 De Laval turbines, tests of at different loads, 303  
 De Laval turbine, transmitting power, 305  
 De Laval turbine wheel, speed of, 302  
 Deposit on economizer tubes, 159  
 Deposit of salts in economizer tubes, 160  
 Description of calorimeters, 44  
 Description of coal, 39  
 Description of compound engines, 221  
 Description of Cornish boilers, 55  
 Description of Cornish valves, 250  
 Description of double-cylinder engines, 220  
 Description of eccentrics, 246  
 Description of Lancashire boilers, 55  
 Description of peat, 40  
 Description of slide valve, 243  
 Description of steam boiler, 53  
 Description of Wheelock valve, 242  
 Desrumaux water softener, construction of, 190  
 Desrumaux water softener, operation of, 191  
 Desrumaux water softener, revolving wheels in, 190  
 Detroit boiler, construction of, 95  
 Detroit water-tube boiler, 95  
 Dew, formation of, 31  
 Diagrams, Bristol's thermo-electric pyrometer, 9  
 Diagrams, Crompton's thermo-electric pyrometer, 8  
 Diaphragms in Rateau turbine, 316  
 Differences between coals, 42  
 Difference in construction of economizers, 161  
 Difference between expansion and throttle governing, 268  
 Difference between pressure and impulse turbines, 291  
 Difference of temperature and efficiency of boiler, 37  
 Difference of temperature and efficiency of plant, 37  
 Difference between water- and fire-tube boilers, 77  
 Difficulties of lubrication of high-speed engines, 240  
 Direct driving and crank shaft, 262  
 Disadvantages of multitubular boilers, 71  
 Dissolved substances and boiling-point of water, 21  
 Dissolved substances and freezing-point of water, 21  
 Distilled water and exhaust from turbines, 329

- Distributing valves of high-speed engines, 231  
 Distributing valve, Willans engine, 232  
 Distribution of steam by pipes, 273  
 Dividing up cylinders for expansion, 217  
 Division of load between ropes, 264  
 Domestic fire-grate, cause of waste, 54  
 Domestic fire-grate, combustion in, 53  
 Domestic fire-grate, waste of heat in, 54  
 Domestic tea kettle, 55  
 Domestic thermometer, 5  
 Donkey boiler for feed pumps, 172  
 Doors of boiler furnaces, 108  
 Double-acting Bumsted engine, 237  
 Double belt, formula for, 264  
 Double-cylinder engines and cranks, 261  
 Double-cylinder engines described, 220  
 Double ported slide valve, construction of, 245  
 Double-ported slide valve, operation of, 245  
 Double tubes in surface condenser, 337  
 Doulton's water softener, construction of, 188  
 Doulton's water softener, operation of, 189  
 Drainage of steam pipes, 278  
 Draught in burning towns refuse, 114  
 Draught, fan, and cooling towers, 375  
 Draught, forced, explanation of, 139  
 Draught, regulation of, with economizers, 162  
 Draught, pressure of air creating, in boiler furnace, 28  
 Dried manure as fuel, 46  
 Drilling boiler shells, 61  
 Driving early Cornish pumps, 260  
 Driving expansion governor, 268  
 Driving pulley of Lancs. mill engines, 241  
 Driving ropes of Lancs. mill engines, 241  
 Driving side of belt, 263  
 Drop valves, 242, 249  
 Drop valves, operation of, 249  
 Drop valves, piston, 250  
 Drop valves, tripping gear for, 249  
 Druitt Halpin's thermal storage, 327  
 Drums in Atlas boiler, 93  
 Drums in "Daring" type boiler, 102  
 Drums in Sinclair boiler, 96  
 Drums of Stirling boiler, 86  
 Drums in Suckling boiler, 96  
 Drums in Thornycroft-Schultz boiler, 100  
 Dry air pump for condenser, 365  
 Dry air pumps, two stage, 365  
 Dry air as a thermal insulator, 12  
 Dry-back boiler, 72  
 Dry-back boiler, construction of, 74  
 Dry steam and lubrication, 231  
 Dulong's formula for calorific value, 39  
 Duplicate cooling towers, 380  
 Dust coal burning apparatus, 110  
 Dust settling apparatus, towns' refuse, 114
- E
- Early forms of steam engines, 214  
 Eaves' dead-weight safety valve, 155  
 Eccentrics, description of, 246  
 Eccentrics and expansion governors, 246  
 Eccentrics and link motion, 247  
 Eccentrics and slide valve, 246  
 Eccentric, operation of, when working expansively, 247  
 Eccentrics for reversing engine, 247  
 Eccentric rod and Corliss valve, 252  
 Eccentrics worked from crank shaft, 262  
 Economic boiler, construction of, 74  
 Economizers, care of, in frosty weather, 162  
 Economizer chamber and air, 163  
 Economizers, construction of, 158  
 Economizer, course of gases and water, 160  
 Economizers, difference in construction of, 161  
 Economizer, Green's, arrangement of, 160  
 Economizer, Green's, capacity of tubes, 160  
 Economizer, heat taken out of gases in, 161  
 Economizers, heating air by, 162  
 Economizers, regulation of draught with, 162  
 Economizer, temperature of water delivered to, 161  
 Economizer tubes, cleaning deposit from, 159  
 Economizer tubes, deposit on, 159  
 Economizer tubes, deposit of salts in, 160  
 Economizer tubes, scrapers for, 159  
 Economy of air- and water-heating economizers, 162  
 Economy claimed with Ellis & Eaves apparatus, 145  
 Economy of condensing with different steam pressures, 367  
 Economy of forced draught, 141  
 Edwards air pump, form of bucket in, 366  
 Edwards air pump, operation of, 366  
 Effect of air in surface condenser, 332  
 Effect of ash on calorific value, 41  
 Effect of initial temperature on cooling water, 358  
 Effect of nitrogen on calorific value, 41

- Effect of oxygen on calorific value in fuels, 38
- Effect of pressure on surface of liquid on boiling-point, 19
- Effect of scale upon boiler working, 181
- Effect of seasons upon chimney draught, 135
- Effect of temperature of water on injector, 178
- Effect of tension of water vapour, 31
- Effect of water vapour in air on boiler furnace, 27
- Effective area of chimneys, formula for, 135
- Effective pressure, mean, in steam engines, 215
- Effective pressures with varying cut-offs, compared, 215
- Efficiency of belt drive, 265
- Efficiency of boiler and difference of temperature, 37
- Efficiency of chimneys, 131
- Efficiency of condenser, Prof. Weighton, 361
- Efficiency of engine explained, 220
- Efficiency and leakage of heat, 37
- Efficiency of plant and difference of temperature, 37
- Efficiency of rope drive, 265
- Efficiency of spur gearing, 265
- Efficiency of worm gearing, 265
- Egg-shaped Lancs. boilers, 62
- Ejector condenser, advantages of, 344
- Ejector condenser, arrangement of steam and water pipes, 344
- Ejector condenser, Ledward, 343
- Ejector condenser, operation of, 343
- Elbows, loss of steam pressure in, 275
- Electric controller with Curtis turbine, 311
- Electric governor for Parsons turbine, 297
- Electric motor and pump for condenser, 363
- Electrical distribution and steam compared, 273
- Electrical emulsifier, Davis-Perrett, 198
- Electrically driven boiler-feed pumps, 172
- Electrically driven feed pumps, objection to, 172
- Electricity generators, engines for driving, 239
- Electrolytic action in boilers, 181
- Ellis and Eaves air heating with induced draught, 143
- Ellis and Eaves apparatus, course of air in, 145
- Ellis and Eaves apparatus, economy claimed with, 145
- Ellis and Eaves apparatus, temperature of air, 145
- Emergency governor in Zoelly turbine, 329
- Employment of fan with forced draught, 140
- Emulsifier, electrical, Davis-Perrett, 198
- Enclosed feed-water heaters, construction of, 163
- Enclosed surface condenser, construction of, 331
- Enclosure of high-speed engines, 228
- Ends of Cornish boilers, 62
- Ends of Lancs. boilers, 62
- End thrust in turbine, 294
- Energy, kinetic, conversion from potential, 289
- Energy, kinetic and potential, 289
- Energy, loss of in chimneys, 131
- Engine, central valve, Willans, 232
- Engine, compound, proportion of cylinders in, 221
- Engine governor, construction of, 265
- Engine, high-speed, Bumsted, 236
- Engine, Peache, course of steam in, 238
- Engine, Peache, valves of, 237
- Engine, reversing, by eccentrics, 247
- Engine, steam, reciprocating, 213
- Engine, steam, work will perform, 218
- Engines, Belliss, construction of, 229
- Engines, Brotherhood, construction of, 229
- Engines, Browett, construction of, 229
- Engines, compound, described, 221
- Engines, compound, vertical, arrangement of, 239
- Engines, double-cylinder, described, 220
- Engines for driving compressed air machinery, 239
- Engines for driving electricity generators, 229
- Engines, government of, 265
- Engines, high-speed, 227
- Engines, intermediate-speed, 227
- Engines, low-speed, 227
- Engines, mill, Lancs., 240
- Engines, piston speed of, 227
- Engines, pumping, Cornish, 213
- Engines, quadruple expansion, 227
- Engines, quickly revolving, 228
- Engines, reciprocating valves for, 242
- Engines, steam, early forms, 214
- Engines, steam, expansive working with, 214
- Engines, steam, working without expansion, 214
- Engines, triple-expansion, 226
- Engines, twin-cylinder, arrangement of, 239
- Engines, use of flywheels with, 239

- Engines, vertical and horizontal, 239  
 Entropy, explanation of, 9  
 Enumeration of boiler fittings, 151  
 Erith underfed mechanical stoker, 126  
 Ether and heat, 2  
 Ether all pervading, 2  
 Ether and planetary space, 2  
 Ether, what it is, 1  
 Euston steam trap, construction of, 286  
 Evaporation from cooling ponds, 369  
 Evaporation and humidity of atmosphere, 335  
 Evaporation from spraying nozzles, 370  
 Evaporation, variation of, with weather, 369  
 Evaporation of water, cooling effect of, 335  
 Evaporation, water lost by, 335  
 Evaporative condenser, Fraser, 335  
 Evaporative condenser, water used with, 335  
 Evaporative surface condenser, construction of, 334  
 Evaporator, Central Engineering Co., 205  
 Evaporators, construction of, 205  
 Evaporators, Royle, 205  
 Evaporators, use of, 205  
 Evaporators, Weir, 205  
 Exhaust and live steam, combination of, for turbines, 325  
 Exhaust from turbines and boiler feed, 329  
 Exhaust from turbines and distilled water, 329  
 Exhaust steam, adaptability for turbines, 323  
 Exhaust steam for feed-water heaters, 164  
 Exhaust steam and injector, 175  
 Exhaust steam, storage of, for turbines, 324  
 Exhaust steam, turbines working with, 322  
 Exhaust steam and Zoelly turbine, 323  
 Expansion bends in steam pipes, 279  
 Expansion of bodies with heat, 16  
 Expansion of brass and iron, 6  
 Expansion and contraction of air with temperature, 25  
 Expansion and contraction of steam pipes, 279  
 Expansion, division of cylinders for, 217  
 Expansion governor, construction of, 267  
 Expansion governor, driving, 268  
 Expansion governors and eccentrics, 246  
 Expansion governor, operation of, 267  
 Expansion governor, Wilson Hartnell, 267  
 Expansion pyrometer, 6  
 Expansion, quadruple engines, 227  
 Expansion of steam adiabatically, 290  
 Expansion of steam in De Laval turbine, 301  
 Expansion of steam for velocity turbine, 290  
 Expansion and throttle governing, difference between, 268  
 Expansion, triple engines, 226  
 Expansion of water in freezing, 16  
 Expansive working and cylinder condensation, 215  
 Expansive working in steam engines, 214  
 Expansive working, temperature of cylinder walls with, 217  
 Expansive working and water vapour, 217  
 Experiments, condenser, Richard Allen, 352  
 Experiments on condensers, Prof. Weighton, 360  
 External furnaces, Cornish boilers, 69  
 External furnaces, Lancashire boilers, 69
- F
- Fahrenheit scale, 4  
 Fan, arrangement of, with induced draught, 141  
 Fan centrifugal, construction of, 146  
 Fans for mechanical draught, 145  
 Fan, power required to drive, 147  
 Fan, propeller, use of, 146  
 Fan draught and cooling towers, 375  
 Feed of underfed mechanical stokers, 126  
 Feeding mechanical stokers, 118  
 Feed-pumps and donkey boiler, 172  
 Feed-water heaters and air vessels, 169  
 Feed-water heater, Climax boiler, 99  
 Feed-water heaters and exhaust steam, 164  
 Feed-water heaters and live steam, 164  
 Feed-water heater, live steam, Holden & Brooke, 166  
 Feed-water heaters, open steam, arrangement of, 168  
 Feed-water heater as purifier, 167  
 Feed-water heater, Royle, 166  
 Feed water in Atlas boiler, 93  
 Feed water in Stirling boiler, 86  
 Feed water, matter contained in, Prof. Thurston's estimate, 179  
 Feed water, methods of removing foreign bodies from, 181  
 Feed water, objection to condensed water for, 169  
 Feed-water pumps, forms of, 170

- Feed water purifying, 179  
Feed-water regulators, 178  
Feed water, substances contained in, 179  
Feed water, temperature obtainable with exhaust steam, 166  
Feed water, use of hot gases for, 156  
Ferranti-Hopkinson stop-valve, 257  
Filter cleaning in Reiser water softener, 188  
Filter in Bruun-Lowener water softener, 188  
Filter in Criton water softener, 185  
Filters and water softeners, 183  
Finely divided charcoal, properties of, 13  
Finely divided substances in water and boiling-point, 21  
Finely divided substances, thermal conductivity, 12  
Fire bars in Auto stoker, 123  
Fire bars, interlocking, Meldrum, 115  
Fire bars, movement of, in Vickers stoker, 123  
Fire bar, rocking, Neemes, 110  
Fire bars, rocking, Neil, 108  
Fire bars, water-tube boilers, 82  
Fire grate, Neil, 109  
Firing Cornish boilers, 69  
Firing Lancs. boilers, 69  
Fire-tube boilers, description of, 55  
Flash point of liquid fuels, 47  
Fletcher's oil separator, construction of, 194  
Flexible shaft in De Laval turbine, 303  
Flow of steam through pipes, table of, 276, 277  
Flow of water in injector, 175  
Flue dampers, operation of, 148  
Flues of Cornish boilers, 56  
Flues of Lancashire boilers, 56  
Flue gases, object of testing, 205  
Flue gases, percentage of  $\text{CO}_2$  and loss of fuel, 207  
Flue gas testers, principle of, 207  
Flue gas testing apparatus, Orsat, 212  
Flywheel speeds of high and low speed engines, 228  
Flywheels, use of, with engines, 239  
Forced draught, air required with, 141  
Forced draught, with air heating, 139  
Forced draught, closed ashpit system, 139  
Forced draught, closed fire-room system, 139  
Forced draught, cost of producing, 141  
Forced draught, economy with, 141  
Forced draught, explanation of, 139  
Forced draught, higher pressure obtained with, 140  
Forced draught, temperature of gases with, 140  
Formula for calorific value, Dulong, 39  
Formula of Carnot's law, 36  
Formula for converting Centigrade to Fahrenheit, 5  
Formula for cooling water required with condensers, 351  
Formula for double belt, 264  
Formula for effective area of chimney, 135  
Formula for Fahrenheit to Centigrade, 5  
Formula for Green's economizer, 160  
Formula for horse-power of steam engine, 218  
Formulae for loss of pressure in steam pipes, 274  
Formula for power to move air, 147  
Formula for pressure in boilers, 80  
Formula for rate of transmission of heat, 12  
Formula for size of belt, 263  
Formula for sizes of rope, 265  
Formula for velocity of gases in chimney, 133  
Formula for volume and pressure of gas, 289  
Foundations of chimneys, 138  
Foundations for Lancs. mill engines, 241  
Fraser and Chalmers compound Cornish boiler, 76  
Fraser's condenser, advantages claimed for, 336  
Fraser's evaporative condenser, 335  
Freezing-point on Centigrade scale, 4  
Freezing-point on Fahrenheit scale, 4  
Freezing-point on Reaumur scale, 4  
Freezing-point of water and dissolved substances, 21  
Friction of slide valve on cylinder, 248  
Friction of steam in pipes, heat generated by, 274  
Fuel, air required for combustion of, 130  
Fuel, approximate analysis of, 43  
Fuel, dried manure, 46  
Fuel, gaseous, 49  
Fuel, liquid, burning apparatus, 111  
Fuel, loss of, and percentage of  $\text{CO}_2$ , 207  
Fuel, saw-dust, 46  
Fuel, ultimate analysis of, 43  
Furnace bars, special forms of, 108  
Furnaces, boiler, doors of, 108  
Furnace, combustion of fuel, 37  
Furnace draught by steam jets, 147  
Furnace gases, course of, in locomotive boiler, 73  
Furnace gases, course of, in marine boiler, 74  
Furnace gases, splitting up, in multi-tubular boilers, 71  
Furnace grates, Cornish boilers, 107  
Furnace grates in Lancs. boilers, 107

Furnace grates, marine boilers, 107  
 Furnace grates, water-tube boilers, 107  
 Furnaces of Lancs. boilers, 56  
 Furnace, methods of providing air for, 127  
 Furnace in Nesdrum boiler, 87  
 Furnace of Stirling boiler, 84  
 Furnace of Woodeson boiler, 88  
 Furnace ventilation in mines, 127  
 Furnace ventilation, motive column for, 128

## G

Galloway boiler for burning refuse, 70  
 Galloway boiler, construction of, 70  
 Galloway cone tubes, description of, 59  
 Galloway cone tube, early form, 60  
 Galloway cone tube, modern form, 60  
 Galloway superheater, 203  
 Galloway water-tube boiler, 93  
 Galvanized iron mats in cooling towers, 377  
 Gas, solution of, in water, 33  
 Gas tar, calorific value of, 48  
 Gas tar, composition of, 48  
 Gas tar as fuel, 48  
 Gas tar, production of, 48  
 Gases in atmosphere, 18  
 Gases found in collieries, description of, 52  
 Gases, specific heats of, 14, 30  
 Gases, volume of, produced by combustion, 130  
 Gases and water, course of, in economizer, 160  
 Gaseous condition, 17  
 Gaseous fuel, 49  
 Gauge cocks, explanation of, 151  
 Gauge pressure, definition of, 22  
 Gearing of De Laval turbine, 305  
 Giving motion to the slide valve, 246  
 Globe stop valves, 255  
 Governor, control of steam supply by, 243  
 Governor of Curtis turbine, 311  
 Governors on end of crank-shaft, 269  
 Governor of Hamilton Holzwarth turbine, 321  
 Governors of high-speed engines, 231  
 Governor of Parsons turbine, 296  
 Governor of Peache engine, 239  
 Governor, Pickering, 265  
 Governor of Rateau turbine, 316  
 Governor of steam engine, use of, 242  
 Governor and stop valve, 255  
 Governor of Willans engine, 235  
 Governor of Zoelly turbine, 320  
 Government of De Laval turbine, 303  
 Government of engines, 265

Gradation of coals, 41  
 Grate area of furnace required, 132  
 Grate area, proportion to chimney, 132  
 Grate bars of over-feed stokers, 120  
 Grate bars, Neil, 109  
 Great Calorie, 14  
 Green's economizer, arrangement of, 160  
 Green's economizer, formula for, 160  
 Guttman water softener, construction of, 188  
 Guttman water softener, operation of, 188

## H

Halpin, Druitt, thermal storage, 327  
 Hamilton Holzwarth turbine, bearings of, 321  
 Hamilton Holzwarth turbine, construction of, 321  
 Hamilton Holzwarth turbine, governor of, 321  
 Hamilton Holzwarth turbine, lubrication of, 321  
 Hard water, explanation of, 180  
 Hardwick feed-water heater, 164  
 Harris-Anderson apparatus, course of water and re-agents in, 193  
 Harris-Anderson apparatus for removing oil, 198  
 Harris-Anderson water softener, construction of, 192  
 Harris-Anderson water softener, mixing tubes, 192  
 Harris-Anderson water softener, operation of, 192  
 Harris-Anderson water softener, treatment vessels, 192  
 Headers in Atlas boiler, 93  
 Headers in Babcock boiler, 83  
 Headers in Davey-Paxman boiler, 91  
 Headers in Wood boiler, 92  
 Heat absorbed by cooling water, 333  
 Heat absorption and Prof. Tyndal, 11  
 Heat applied to bi-carbonates, 33  
 Heat in compressed air, Willans engine, 234  
 Heat conduction and air, 10  
 Heat conduction and metals, 10  
 Heat contained in the earth, 2  
 Heat and convection, 9  
 Heat engines, Carnot's law, 36  
 Heat and expansion of bodies, 16  
 Heat from other planets, 2  
 Heat from the sun, 2  
 Heat generated by friction of steam in pipes, 274  
 Heat liberated by carbon-forming carbonic oxide, 38



- Heat liberated by solution of gas in water, 33  
 Heat liberated, formation of  $\text{SO}_2$ , 38  
 Heat liberated in forming carbonic acid, 38  
 Heat liberated when hydrogen combines with oxygen, 38  
 Heat radiation, 9  
 Heat rays from a black body, 3  
 Heat rays reflected, 3  
 Heat taken out of gases in economizer, 161  
 Heat, theory of, 1  
 Heat, transmission, 9  
 Heat waves, lengths of, 2  
 Heat waves, properties of, 2  
 Heat, what it is, 1  
 Heating air by economizers, 162  
 Heating of belt pulleys, 263  
 Heating curves with plain and corrugated tubes, Wainwright, 167  
 Heating feed-water for boilers, 156  
 Heating of water in Bruun Lowener water-softener, 188  
 Height of chimney cooling towers, 375  
 Height of chimney and intensity of draught, 137  
 Height of chimney and velocity of gases, 133  
 Height of chimneys, Kent's table for, 135  
 Heine boiler, construction of, 95  
 Heine water-tube boiler, 95  
 Henderson mechanical stoker, 119  
 High- and low-speed engines, piston speed of, 228  
 High latent heat, effect on size of steam engines, 23  
 High pressure and Lancs. boilers, 80  
 High pressures, strain on boiler shell, 80  
 High-speed engine, Bumsted, 236  
 High-speed engines, difficulties of lubricating, 240  
 High-speed engines, distributing valves of, 231  
 High-speed engines, enclosure of, 228  
 High-speed engines, governors of, 231  
 High-speed engines, iron used in, 231  
 High-speed engines, lubricant of, 231  
 High-speed engines, lubrication of, 228  
 High-speed engines, lubrication working out from, 240  
 High-speed engines, oil pumps for, 232  
 High-speed engine, Scott & Mountain, construction of, 232  
 High vacua and cooling water, 351  
 High-water safety apparatus, 155  
 Higher pressure obtained with forced draught, 140  
 Highest efficiency speed, De Laval turbine, 302  
 Hodgkinson mechanical stoker, 122  
 Holden & Brooke's feed-water heater for live steam, 166  
 Holden & Brooke's injectors, 176  
 Holden liquid fuel apparatus, arrangement of, 112  
 Hopkinson central pressure stop valve, 257  
 Hopkinson central pressure valve, construction of, 257  
 Hopkinson-Ferranti stop valve, 257  
 Hopkinson's parallel-slide stop valve, 256  
 Hopkinson stop valve, central pressure, 257  
 Hoppes feed-water heater and purifier, 163  
 Horizontal compound engines, arrangement of, 239  
 Horizontal cross-compound condensing engine, 224  
 Horizontal engine and vertical boiler, 223  
 Horizontal tandem compound condensing engine, 224  
 Horizontal tandem compound engine, 223  
 Horizontal triple-expansion condensing mill engine, 240  
 Horizontal triple - expansion engines, arrangement of, 239  
 Horizontal and vertical engines, 239  
 Horse-power, 15  
 Horse-power of boilers discussed, 132  
 Horse-power, brake, measurement of, 220  
 Horse-power and the British thermal unit, 15  
 Horse-power of engine with multiple cylinders, 320  
 Horse-power, indicated, 219  
 Horse-power of steam engine, formula for, 218  
 Hot gases in chimney, pressure of, 133  
 Hot gases, course of, in Atlas boiler, 94  
 Hot gases, course of, in Nesdrum boiler, 87  
 Hot gases, course of, in Stirling boiler, 84  
 Hot gases, course of, with forced draught, 140  
 Hot gases, limit to use of, for feed-water heating, 158  
 Hot gases, limiting temperature in chimney, 129  
 Hot gases, passage of, in Cornish boilers, 56  
 Hot gases, passage of, in Lancs. boilers, 56  
 Hot gases, temperature of, in boiler furnace, 131  
 How power is transmitted by belt, 262  
 Humidity of air, degrees of, 28  
 Humidity of atmosphere and evaporation, 35

Hutton's table of pressures for different fuels, 130  
 Hydrogen in atmosphere, 18  
 Hydrogen combining with oxygen, heat liberated, 38

## I

Ignition point of liquid fuels, 48  
 I.H.P. and cooling surface in condenser, 352  
 Importance of circulation in boilers, 54  
 Importance of mixing reagents in water softeners, 182  
 Impurities in water and priming, 34  
 Inches and pounds, vacuum in, 332  
 Incidence, angle of, 4  
 Inclination of steam pipes, 278  
 Increase of boiling temperature with pressure, 21  
 Increase of efficiency of steam turbine by increased vacuum, 37  
 Increase of pressure on surface of liquid, 19  
 Increase of velocity of steam in De Laval turbine, 301  
 Increase of velocity of steam with lowered pressure, 291  
 Increased pressure, decrease of latent heat, 23  
 Indicated horse power, 219  
 Indications of the barometer explained, 19  
 Indicator cards, atmospheric line on, 272  
 Indicator cards, planimeter for, 272  
 Indicator cards, pressures shown on, 272  
 Indicator cards from steam engine, 271  
 Indicator for steam engine, 219  
 Indicator, steam engine, operation of, 271  
 Induced draught, advantages of, 143  
 Induced draught and air heating, 143  
 Induced draught and air leakage, 143  
 Induced draught, arrangement of fan with, 141  
 Induced draught, course of gases and air with, 142  
 Induced draught, explanation of, 141  
 Induced draught, power required with, 142  
 Induced draught, volume of gases with, 142  
 Infra red rays, 3  
 Initial temperature and cooling water, 358  
 Initial temperature and cooling water required, 351  
 Injector, construction of, 174  
 Injector and critical temperature of water, 178

Injector, Davies & Metcalfe, 176  
 Injector, effect of temperature of water on, 178  
 Injector with exhaust steam, 175  
 Injector, flow of water in, 175  
 Injectors, Holden & Brooke's, 176  
 Injector lift and quantity, 177  
 Injector with live and exhaust steam, 175  
 Injector, operation of, 174  
 Injector, pipes connected to, 175  
 Injector, pressure, can work against, 174  
 Injector, principle of, 173  
 Injector, quantity of water delivered by, 176  
 Injector, supply of water for, 177  
 Injector, temperature of feed with, 176  
 Insulators, thermal, 11  
 Intensity of draught and height of chimney, 137  
 Interlocking fire bars, Meldrum, 115  
 Intermediate-speed engines, 227  
 Intermediate turbines, 289  
 Invisible heat rays, 3  
 Iron for cooling towers, 379  
 Iron plates in cooling towers, 377  
 Iron used in high-speed engines, 231  
 Iron-work for water tube boilers, 78

## J

Jacketing steam cylinders for condensation, 217  
 Jet condenser, air pump for, 340  
 Jet condenser, Balcke, 340  
 Jet condenser and cooling tower, 340  
 Jet condenser, Mirrlees Watson, 341  
 Jet condensers, parallel current, 340  
 Jet condenser, pumps for, 340  
 Jet condenser *versus* surface condensers, 341  
 Jet condenser with water trays, 341  
 Jet condenser, Worthington, pump for, 343  
 Jet condenser, Worthington, velocity of steam in, 343  
 Jet condenser, Worthington, water jet in, 342  
 Jointing rings for steam pipes, 280  
 Jointing of steam pipes, 278  
 Joints of boiler flues, 63  
 Joints in boiler shells, 61  
 Joule's equivalent, 15

## K

Keeler rocking fire grate, 109  
 Kennicott water softener, construction of, 189  
 Kent's table for the height of chimneys, 135

Kinetic energy, conversion from potential energy, 289  
 Kinetic energy and potential energy, 289  
 Koppel, Arthur, water softener, construction of, 191  
 Koppel, Arthur, water softener, operation of, 191  
 Koppel, Arthur, water softener, steam heating apparatus in, 191  
 Korting's liquid-fuel burning apparatus, 113

## L

Lagonda damper regulator, 149  
 Lancaster steam trap, construction of, 283  
 Lancs. boilers, ash pit, 59  
 Lancs. boilers, construction of, 60  
 Lancs. boilers, description of, 55  
 Lancs. boilers, egg shape, 62  
 Lancs. boilers, ends of, 62  
 Lancs. boilers, external furnaces, 69  
 Lancs. boilers, firing, 69  
 Lancs. boiler flues, 56, 63  
 Lancs. boilers, furnaces of, 56  
 Lancs. boilers, furnace grates, 107  
 Lancs. boilers and high pressure, 80  
 Lancs. boilers, hot gases, passage of, 56  
 Lancs. boilers, mud hole, 59  
 Lancs. boilers, radiation from, 58  
 Lancs. boilers, setting, 68  
 Lancs. boilers, sizes of, 62  
 Lancs. boiler, Tinker's superheater fitted to, 201  
 Lancs. boilers, water below furnace, 59  
 Lancs. boilers, water in, 58  
 Lancs. cotton mills and cooling ponds, 368  
 Lancs. mill engines, condensers fixed in, 241  
 Lancs. mill engine, driving pulley of, 241  
 Lancs. mill engine, driving ropes of, 241  
 Lancs. mill engines, foundations for, 241  
 Lancs. mill engines and rope drive, 240  
 Lancs. mill engines, speed of driving ropes, 241  
 Lancs. mill engines, Wheelock expansion gear for, 241  
 Lancs. *versus* Cornish boiler, 60  
 Lap joints, boiler shells, 61  
 Lap of slide valve, 248  
 Largest diameters of vessels in water-tube boilers, 81  
 Latent heat, 16  
 Latent heat, decrease of, with increased pressure, 23  
 Latent heat of steam, 17  
 Latent heat and variation of pressure, 22

Latent heat of water, 17  
 Launch type Thornycroft boiler, 102  
 Law of capacity of air for water vapour, 25  
 Law, Carnot, heat engines, 36  
 Laws of reflection, 3  
 Laws of refraction, 3  
 Law of successive changes of heat, 36  
 Lead of slide valve, 248  
 Leakage of heat and efficiency, 37  
 Leakage of steam and slide valve, 247  
 Ledward ejector condenser, 343  
 Length of radius of crank, 261  
 Length of turbine, 294  
 Lever safety valve, 154  
 Lift of injector and quantity, 177  
 Lifting of water by steam traps, 281  
 Light waves, lengths of, 2  
 Lignites, composition of, 41  
 Limit for circulating water employed, Prof. Weighton, 363  
 Limiting temperature of cooling water, 332  
 Limiting temperature of hot gases in chimney, 129  
 Limit to use of hot gases for feed-water heating, 158  
 Link motion for eccentrics, 247  
 Link motion and slide valve, 247  
 Liquid condition, 17  
 Liquid fuels, 46  
 Liquid fuel apparatus, Holden, 111  
 Liquid fuel burning apparatus, Korting, 113  
 Liquid fuel burning apparatus, Marshall, 112  
 Liquid fuels, flash point, 47  
 Liquid fuels, ignition point, 48  
 Liquids, specific heats of, 13  
 Live steam and feed-water heaters, 164  
 Lloyd's, explanation of, 68  
 Lloyd's formula boiler furnaces, 65  
 Locke's damper regulator, 150  
 Locomotive boiler, construction of, 73  
 Loss of energy in chimneys, 131  
 Loss of heat by radiation from steam pipes, 275  
 Loss of pressure in steam pipes, formulæ for, 274  
 Loss of steam pressure in elbows, 275  
 Loss of steam pressure in valves, 275  
 Loss of water in cooling towers, 380  
 Loss of water with spraying nozzles, 370  
 Louvre boards for cooling ponds, 370  
 Low pressures, high latent heat, 23  
 Low-speed engines, 227  
 Low steam pressures and size of steam engines, 23  
 Low-water safety apparatus, 155  
 Low-water safety valve, 155

- Lowered pressure, increase of velocity of steam with, 291  
 Lubricant for high-speed engines, 231  
 Lubrication of Bumsted engine, 236  
 Lubrication of Curtis turbine, 311  
 Lubrication and dry steam, 231  
 Lubrication of Hamilton Holzwarth turbine, 321  
 Lubrication of high-speed engines, 228  
 Lubrication in Parsons turbine, 296  
 Lubrication of Peache engine, 237  
 Lubrication and superheated steam, 231  
 Lubrication and superheated steam in turbines, 328  
 Lubrication of Willan's turbine, 300  
 Lubrication working out from high-speed engines, 240
- M
- Marine boiler, 72  
 Marine boiler, Babcock, 83  
 Marine boiler, construction of, 74  
 Marine boilers, furnace grates, 107  
 Marriott steam separators, construction of, 203  
 Marshall's boiler, steam drums, 91  
 Marshall's boiler, water legs, 91  
 Marshall's liquid fuel burning apparatus, 112  
 Marshall's water-tube boiler, 91  
 Marshall's water-tube boiler, construction of, 91  
 Marshall's water-tube boiler, course of hot gases, 91  
 Matter, three states of, 16  
 McLeod's and Henry's boiler brickwork, 69  
 Mean back pressure in cylinder, 218  
 Mean effective pressure explained, 215, 218  
 Mean effective pressure in steam engines, 215  
 Mean pressures, table of, 216  
 Measurement of brake horse-power, 220  
 Measurement of reagents in Bruun-Lowener water softener, 187  
 Measurements of reagents in Criton softener, 184  
 Measurement of reagent in Reisert water softener, 186  
 Measurement of ropes, 264  
 Measurement of temperatures, 5  
 Measurement of vapour in air, improved method, 29  
 Measurement of wood, 45  
 Measuring percentage of water vapour in air, 28  
 Mechanical draught, fans for, 145  
 Mechanical draught, rates of combustion with, 133  
 Mechanical draught, sizes of fan for, 146  
 Mechanical equivalent of heat explained, 15  
 Mechanical stokers, advantages of, 115  
 Mechanical stoker, Bennis, 122  
 Mechanical stokers, chain grate, 124  
 Mechanical stokers, coking, 117  
 Mechanical stokers, feeding, 118  
 Mechanical stoker, Henderson, 119  
 Mechanical stoker, Hodgkinson, 122  
 Mechanical stokers, overfeed, 117  
 Mechanical stokers, rate of combustion with, 117  
 Mechanical stokers, requirements of, 115  
 Mechanical stoker, sprinkler, 118  
 Mechanical stokers and steam jets, 122  
 Mechanical stoker, underfeed, Erith, 126  
 Mechanical stokers underfeed, feed of, 126  
 Mechanical stoker, Underfeed Stoker Co., 126  
 Mechanical stoker, Wilkinson, 122  
 Mechanical Theory of Heat, 1  
 Megasse, calorific value of, 45  
 Meldrum's coal-dust furnace, 110  
 Meldrum's coker stoker, 119  
 Meldrum's colliery refuse destructor, 114  
 Meldrum's furnace for colliery refuse, 170  
 Meldrum's interlocking fire bars, 115  
 Meldrum's refuse destructor grate, 115  
 Meldrum's steam jet furnace draught, 147  
 Melting points of metals, 6  
 Mercurial barometer, 18  
 Mercurial thermometer to 800° F., 5  
 Metals and heat conduction, 10  
 Methods of curing cylinder condensation, 217  
 Methods of providing air for the furnace, 127  
 Methods of removing foreign bodies from feed water, 181  
 Metropolitan District Railway, Westinghouse turbine, 313  
 Midget steam trap, construction of, 285  
 Mill engines, Lancs., 240  
 Mirrlees Watson jet condenser, £41  
 Mirror, reflected image in, 3  
 Mixing of reagents and water in Bruun-Lowener water softener, 187  
 Mixing tubes in Harris-Anderson water softener, 192  
 Modern form Galloway tube, 60  
 Modern practice, steam pressures used, 36  
 Morrison suspension boiler furnace, 65  
 Motive column and chimney draught, 128  
 Motive column of furnace ventilation, 128  
 Motive column, reasons for, 128

Motor boiler, Turner-Miesse, 106  
 Motor-wagon boilers, Thornycroft, 105  
 Motor-wagon boiler, White, 106  
 Mountain sickness, 20  
 Movement of-fire bars in Vickers stoker, 128  
 Movement of stoker, grate bars, 120  
 Mud drum in Davey-Paxman boiler, 91  
 Mud drum in Nesdrum boiler, 88  
 Mud drums in Stirling boiler, 86  
 Mud drums, use of for removing foreign bodies, 182  
 Mud drums, Woodeson boiler, 90  
 Mud hole in Lancs. boilers, 59  
 Mud precipitate in Archbutt-Deely apparatus, 184  
 Multiple cylinders, horse-power of engine with, 220  
 Multitubular boilers, advantages of, 71  
 Multitubular boilers, construction of, 70  
 Multitubular boiler, Davey-Paxman, 72  
 Multitubular boilers, disadvantages of, 71  
 Multitubular boiler, forms of, 72  
 Multitubular and Cornish boiler, 76

## N

Natural gas, calorific value, 52  
 Natural gas, composition of, 52  
 Natural gas, production of, 51  
 Natural mineral springs, 32  
 Neemes rocking fire bar, 110  
 Neil's fire grate, 109  
 Neil's rocking fire bars, 108  
 Nesdrum boiler, construction of, 87  
 Nesdrum boiler, furnace in, 87  
 Nesdrum boiler, hot gases, course of, 87  
 Nesdrum boiler, mud drum, 88  
 Nesdrum boiler, steam drum, 88  
 Nesdrum boiler, superheater, 88  
 Nesdrum boiler, tubes in, 87  
 Nesdrum boiler, water circulation, 88  
 Nesdrum superheater, 202  
 Nesdrum water-tube boiler, 87  
 Nominal horse-power explained, 220  
 Nozzles for cooling ponds, 369  
 Nozzle in De Laval turbine, 301  
 Nozzles, spraying, evaporation from, 370

## O

Oil catcher and steam exhaust head, 197  
 Oil pumps for high-speed engines, 231  
 Oil pumps in Parsons turbine, 296  
 Oil relay in Zoelly turbine governor, 320  
 Oil removing, apparatus for, Harris-Anderson, 198  
 Oil removing, special apparatus for, 197

Oil separators, construction of, 193  
 Oil separator, Fletcher, construction of, 194  
 Oil separator, Reid, construction of, 195  
 Oil separator vacuum, Cochrane, 195  
 Oil from water, removing, 193  
 Olefine, 47  
 Open steam feed-water heaters, arrangement of, 168  
 Open tank surface condensers, 338  
 Origin of petroleum, 46  
 Orsat apparatus, construction of, 212  
 Orsat apparatus for flue gas testing, 212  
 Orsat apparatus, operation of, 212  
 Overfeed mechanical stokers, 117  
 Overfeed stokers, grate bars of, 120  
 Overload valve in Zoelly turbine, 321  
 Oxygen in atmosphere, 18  
 Oxygen, effect of in calorific value in fuels, 88  
 Oxygen for furnace, effect of water vapour in air, 27

## P

Paraffin, 47  
 Parallel current jet condensers, 340  
 Parallel slide stop valve, advantages of, 257  
 Parallel slide stop valve, construction of, 256  
 Parallel slide stop valve, operation of, 257  
 Parsons dummy axle in turbine, 294  
 Parsons early duplicate turbine, 294  
 Parsons turbine, bearings of, 295  
 Parsons turbine blades, 294  
 Parsons turbine, construction of, 294  
 Parsons turbine electric governor, 297  
 Parsons turbine, governor of, 296  
 Parsons turbine governor, relay valve, 297  
 Parsons turbine, lubrication in, 296  
 Parsons turbine, oil pump in, 296  
 Parsons turbine and ship propellers, 299  
 Parsons turbo pump, 298  
 Parsons' vacuum augmentor, 347  
 Peache engine, construction of, 237  
 Peache engine, course of steam in, 238  
 Peache engine, governor of, 239  
 Peache engine, lubrication of, 237  
 Peache engine, valves of, 237  
 Peache engine, valve motion, range of, 239  
 Pearn's wall pump, 173  
 Peat, composition of, 40  
 Peat, description of, 40  
 Percentage of CO<sub>2</sub> in flue gas and loss of fuel, 207  
 Percentage of water vapour in air, measuring, 28

- Period steam remains in engine, Willans engine, 234  
 Permanent hardness in water, explanation of, 180  
 Petroleum, composition of, 46  
 Petroleum, forms of, 46  
 Petroleum, groups of, 47  
 Petroleum, origin of, 46  
 Petroleum, production of, 47  
 Petroleum from shales, 48  
 Petroleum, weight of, 47  
 Pickering governor, operation of, 266  
 Pipes connected to injector, 175  
 Pipes, distribution of steam by, 273  
 Pipes, friction of steam in, heat generated by, 274  
 Pipes, steam, 273  
 Pipes, steam, arrangement of, 273  
 Pipes, velocity of steam in, 274  
 Piston drop valves, 250  
 Piston, power from, 260  
 Piston rod and crank shaft, 260  
 Piston slide valve, 248  
 Piston slide valve, construction of, 248  
 Piston slide valve, operation of, 249  
 Piston speed of high and low-speed engines, 228  
 Piston speed of engines, 227  
 Planimeter for indicator cards, 272  
 Plunger pumps for condenser, 363  
 Plunger pumps with variable stroke, 365  
 Pochahontas coals, 41  
 Pockets in steam pipes, 278  
 Polarization, 4  
 Ponds, cooling, with nozzles, 368, 369  
 Ponds, sizes of, for cooling condensing water, 369  
 Potential energy and kinetic energy, 289  
 Pounds and inches, vacuum in, 332  
 Power absorbed by condensing plant, 367  
 Power from the piston, 260  
 Power required to drive fan, 147  
 Power required to move air, 147  
 Power required with induced draught, 142  
 Power taken from the crank shaft, 261  
 Power, transmitting, De Laval turbine, 305  
 Power varies as cube of velocity, 147  
 Pressure of air for boiler furnace and water vapour, 28  
 Pressure of air creating draught in boiler furnace, 28  
 Pressure of the atmosphere, variation of, 19  
 Pressure back in cylinder, 218  
 Pressure in boilers, formula for, 80  
 Pressure in centrifugal fan, how produced, 146  
 Pressure in chimney cooling tower, 373  
 Pressures in chimney with different temperatures outside, 134  
 Pressure of column of hot gases in chimney, 133  
 Pressure corresponding to 1-inch water gauge, 129  
 Pressure, effective, mean in steam engines, 215  
 Pressures, effective, with varying cut-offs, 215  
 Pressure of fan for mechanical draught, 146  
 Pressure and impulse turbines, difference between, 291  
 Pressure, increase of, and boiling temperature, 21  
 Pressure, increase on surface of liquid, 19  
 Pressure injector can work against, 174  
 Pressures required for boiler work, 130  
 Pressures required for different fuels, 130  
 Pressures shown on indicator cards, 272  
 Pressure, steam, loss of in elbows, 275  
 Pressure, steam, loss of in valves, 275  
 Pressure steam turbine, 288  
 Pressure and superheating, 35  
 Pressure and temperature, 4  
 Pressure turbine, action of steam in, 292  
 Pressure turbines, compounding in, 292  
 Pressure turbine, course of steam in, 291  
 Pressure of vapour from surface of water, 19  
 Pressure and volume, 29  
 Pressure and volume of gas, formula for, 289  
 Priming, and impurities in water, 34  
 Prismatic colours, 2  
 Proctor's mechanical stoker, construction of, 117  
 Producer gas, calorific value of, 50  
 Producer gas, composition of, 50  
 Producer gas, production of, 49  
 Proell governor, construction of, 266  
 Proell governor, operation of, 266  
 Prof. Rateau and exhaust steam working, 322  
 Prof. Thurston's estimate of matter in feed water, 179  
 Prof. Thurston's standard for chimneys, 132  
 Prof. Tyndal and heat absorption, 11  
 Prof. Weighton, air pump capacity for condenser, 361  
 Prof. Weighton, condenser employed by, 360  
 Prof. Weighton, cost of circulating water, 363  
 Prof. Weighton's experiments on condensers, 360  
 Prof. Weighton, limit for circulating water employed, 363

- Propeller fan, construction of, 145  
 Propeller fan, use of, 146  
 Protection of cooling towers without vertical draught, 371  
 Pulleys for belt driving, 262  
 Pulsometer feed pump, construction of, 171  
 Pulsometer, operation of, 171  
 Pumps, air, for condenser, 365  
 Pump, air, for jet condenser, 340  
 Pump for barometric condenser, 346  
 Pump, centrifugal, for condenser, 363  
 Pumps for condensers, 363  
 Pumps, Cornish, driving, 260  
 Pumps for jet condenser, 340  
 Pumps, oil, for high-speed engines, 231  
 Pumps, plunger, with variable stroke, 365  
 Pumps, rods for, 260  
 Pumps for surface condenser, 331  
 Pump for Worthington jet condenser, 343  
 Pumping engines, Cornish, 213  
 Punching boiler plate, 61  
 Pure anthracite coals, composition of, 41  
 Purification of water by feed-water heaters, 167  
 Purifying the feed water, 179  
 Pyrometer, expansion, 6  
 Pyrometer, thermo-electric, 7  
 Pyrometer, thermo-electric, Bristol, 9  
 Pyrometer, thermo-electric, Crompton, 8
- Q
- Quadruple expansion engines, arrangement of cylinders, 227  
 Quickly revolving engines, 228
- R
- Radial bricks for chimneys, 138  
 Radiation of heat, 9  
 Radiation from Lancs. boilers, 58  
 Radiation from steam pipes, 275  
 Rainbow, 2  
 Rain, formation of, 32  
 Rams of coker mechanical stokers, 119  
 Ram pumps, construction of, 170  
 Ranges of valve motion, Peache engine, 239  
 Rateau methods of steam storage, 324  
 Rateau steam storage apparatus, operation of, 325  
 Rateau turbine, clearance in, 316  
 Rateau turbine, construction of, 315  
 Rateau turbine, diaphragms in, 316  
 Rateau turbine, governor of, 316  
 Rates of consumption with mechanical draught, 133  
 Rate of combustion with mechanical stokers, 117  
 Rate of doing work, 15  
 Rate of transmission of heat, formula, 12  
 Reading steam engine indicator cards, 272  
 Reagents, importance of mixing in water softening, 182  
 Reagents, measurement in Criton water softener, 184  
 Reagent, measurement of, in Reisert water softener, 186  
 Reagents used in Criton water softener, 184  
 Reaumur scale, 4  
 Receivers steam, with triple-expansion engines, 227  
 Reciprocating engine and steam turbine compared, 288  
 Reciprocating engines, vacuum with, 327  
 Reciprocating steam engine, 213  
 Reciprocating valves for engines, 242  
 Recorder, CO<sub>2</sub>, Sarco, 208  
 Recorder, CO<sub>2</sub>, Simmance, 210  
 Reducing valve, construction of, 259  
 Reflection, laws of, 3  
 Refraction, laws of, 3  
 Refuse destructor, colliery, Meldrum's, 114  
 Refuse destructor grate, Meldrum's, 115  
 Refuse, towns', burning, 113  
 Regulators, damper, automatic, 149  
 Regulators, feed water, 178  
 Re-heaters for compound engines, construction of, 224  
 Re-heating steam between cylinders, 224  
 Reid oil separator, operation of, 197  
 Reisert water softener, construction of, 186  
 Relative conductive property of thermal insulators, 11  
 Relay valve in Parsons' turbine governor, 297  
 Relief valve, atmospheric, 155  
 Relief valves, steam, 287  
 Relief valves, Willans engine, 235  
 Removing oil from water, 193  
 Removal of solid matter in feed-water heaters, 167  
 Resistance, thermo pyrometer, 7  
 Reservoir steam trap, construction of, 286  
 Reservoirs for water, 32  
 Reversing engine, by eccentrics, 247  
 Revolving wheels in Desrumaux water softener, 190  
 Riblet feed-water heater, 164  
 Rings of boiler shells, arrangement of, 62

- Ring system of steam pipes, 279  
 Riveting boiler shells, 62  
 Robb-Mumford boiler, construction of, 76  
 Rocking fire bars, Neil, 108  
 Rocking fire bar, Neemes, 110  
 Rocking fire grate, Keeler, 109  
 Rod for pumps, 260  
 Ropes, division of load between, 264  
 Rope drive, efficiency of, 265  
 Rope driving and crank shaft, 262  
 Rope drive and Lancs. mill engines, 240  
 Rope pulleys, construction of, 264  
 Ropes, measurement of, 264  
 Rope, sizes, formula for, 265  
 Rotary motion, production of, 260  
 Row flexible water tube, 166  
 Rowland's mechanical equivalent of heat, 15  
 Royle's feed-water heater, 166  
 Royle's evaporators, 205  
 Runners in Zoelly turbine, 319
- S
- Safety and stop valve combined, 156  
 Safety valve, dead weight, 154  
 Safety valve, dead weight, Eaves, 155  
 Safety valves, forms of, 154  
 Safety valve lever, 154  
 Safety valve, low water, 155  
 Safety valve, operation of, 154  
 Safety valves, reason for, 152  
 Safety valve spring, 154  
 Salts, deposit of, in economizer tubes, 160  
 Sarco automatic CO<sub>2</sub> recorder, 208  
 Sarco recorder, construction of, 208  
 Sarco recorder, operation of, 209  
 Saturated steam, properties of, 24, 34  
 Saturated steam, Siebel, 34  
 Saturation of air by water vapour, 27  
 Sawdust as fuel, 46  
 Scale formed by impurities in water, 33  
 Scale forming substances in boiler feed, 181  
 Scales of temperature, 4  
 Schmidt's separately fired superheater, 202  
 Schmidt's superheater for Lancs. boiler, 202  
 Schultz boiler, construction of, 102  
 Schwartzkopff coal-dust burning apparatus, 111  
 Scott and Mountain high-speed engine, construction of, 232  
 Scrapers for economizer tubes, 159  
 Scum cocks and foreign bodies for boilers, 182  
 Season, effect of, on chimney draught, 135
- Secondary governor for Willans turbine, 300  
 Sectional area of chimneys, 132  
 Semi-anthracite coals, composition of, 41  
 Semi-bituminous coals, composition of, 41  
 Semi-bituminous coals, properties of, 42  
 Separate stages in Curtis turbine, 309  
 Separators, oil, construction of, 193  
 Separator, oil, Fletcher, construction of, 194  
 Separator, oil, Reid, construction of, 195  
 Separator, steam, construction of, 203  
 Separator, steam, Simms, 204  
 Setting Cornish boilers, 68  
 Setting Lancs. boilers, 68  
 Settling tank in Criton water softener, 185  
 Settling of the wheel in De Laval turbine, 303  
 Shaft, crank, 260  
 Shales, description of, 46  
 Shales, petroleum from, 48  
 Ship propellers and Parsons turbine, 299  
 Shovels of coker mechanical stokers, 119  
 Siebel and saturated steam, 34  
 Siebel and superheated steam, 35  
 Silicate cotton, properties of, 121  
 Simmance and Abady CO<sub>2</sub> recorder, 210  
 Simmance recorder, construction of, 211  
 Simmance recorder, operation of, 212  
 Simms feed-water heater and purifier, 169  
 Simms steam separator, 204  
 Simple engine, steam, course of, with, 221  
 Sinclair boiler, course of hot gases, 96  
 Sinclair boiler, drums in, 96  
 Sinclair superheater, 203  
 Sinclair water-tube boiler, 96  
 Single acting Bumsted engine, 236  
 Single acting Willans engine, 233  
 Sirius steam trap, construction of, 282  
 Sirius steam trap, operation of, 282  
 Slide valves balanced, 248  
 Slide valve, description of, 243  
 Slide valve, double ported, construction of, 245  
 Slide valve, doubled ported, operation of, 245  
 Slide valve and eccentrics, 246  
 Slide valve and friction, 248  
 Slide valve, giving motion to, 246  
 Slide valve, lap and lead, 248  
 Slide valve and linkage of steam, 247  
 Slide valve and link motion, 247  
 Slide valve, objections to, 247  
 Slide valve, operation of, 245  
 Slide valve, operation of, by eccentric, 246  
 Slide valve, piston, operation of, 248, 249  
 Slipping of belt, 263



- Small vertical boilers, construction of, 104
- Smokeless steam coals of South Wales, 41
- SO<sub>2</sub> formation, heat liberated, 38
- Solid condition, 16
- Solid wooden cores in condenser tubes, 360
- Solids, specific heats of, 13
- Solution of gas in water, 33
- Solution of gases by water, 32
- Solution of rocks by water, 32
- Source of heat, best position of, 55
- South Wales smokeless steam coals, 41
- Specific heat of air, 29
- Specific heat of air with varying pressure, 30
- Specific heat at constant pressure, explanation of, 30
- Specific heat at constant volume, explanation of, 30
- Specific heat, definition of, 13
- Specific heats of gases, 14, 30
- Specific heats of liquids, 13
- Specific heats of solids, 13
- Specific heat of substances used with steam, 14
- Specific heat of superheated steam at atmospheric pressure, 36
- Specific heat and temperature, 14
- Specific heat of various substances, 13
- Spectrum, 2
- Speeds of De Laval turbine, 305
- Speed of De Laval turbine wheel, 302
- Speed of driving ropes, Lancs. mill engine, 241
- Speed of Edwards' air pump, 367
- Speed of highest efficiency, De Laval turbine, 302
- "Speedy" type Thornycroft boiler, 100
- Spent tan, calorific value of, 45
- Spiral baffle plates in Desrumaux water-softener, 190
- Splash bars, convex, for cooling towers, 376
- Splash lubrication explained, 228
- Splitting up of furnace gases in multi-tubular boilers, 71
- Spraying nozzles, evaporation from, 370
- Spraying nozzles, loss of water with, 370
- Spring safety valve, 154
- Sprinkler mechanical stoker, 118
- Spur gearing, efficiency of, 265
- Standard atmospheric pressure, 18
- Standard boiling point of water, 19
- Standard level for boiling point, 18
- Standard pressure for boiling point, 18
- Steam, action of on water in pockets, 275
- Steam adiabatic expansion of, 290
- Steam boiler, description of, 58
- Steam chest of steam engine, 242
- Steam consumption of condensing plant, Richard Allen, 355
- Steam consumption with different vacua, Richard Allen, 353-354
- Steam, course of with compound engine, 221
- Steam, course of in enclosed surface condenser, 331
- Steam, course of, in evaporative condenser, 334
- Steam, course of in simple engine, 221
- Steam, course of in triple expansion engine, 226
- Steam, course of in Willans engine, 233
- Steam cylinders, warming, on starting up, 243
- Steam distribution, Willans engine, 232
- Steam drums in Babcock boiler, 83
- Steam drum, Climax boiler, 99
- Steam drum in Marshall's boiler, 91
- Steam drum, Nesdrum boiler, 88
- Steam and electrical distribution compared, 273
- Steam engines, cut off with, 214
- Steam engines, early forms, 214
- Steam engines, expansive working with, 214
- Steam engine, governor, use of, 242
- Steam engine indicator, 219
- Steam engine indicator, cards, 271
- Steam engine indicator cards, reading, 272
- Steam engine indicator, construction of, 270
- Steam engine indicator, Crosby, 270
- Steam engine indicator, operation of, 271
- Steam engine, reciprocating, 213
- Steam engine, steam chest, 242
- Steam engine, stop valve of, 242
- Steam engine, wall, 222
- Steam engines, water hammer in, 275
- Steam engine, work will perform, 218
- Steam engines, working pressure in, 215
- Steam engines working without expansion, 214
- Steam exhaust head and oil catcher, 197
- Steam, exhaust, turbines working with, 322
- Steam, expansion of in De Laval turbine, 301
- Steam expansion for velocity turbine, 290
- Steam feed pumps, objection to, 172
- Steam feed pumps, waste of steam in, 172
- Steam feed-water heaters, 163
- Steam, flow of through pipes, table of, 276, 277
- Steam gauge, construction of, 152

- Steam heating apparatus in Arthur Koppel water softener, 191  
 Steam jacketing cylinders for condensation, 217  
 Steam jets, advantages claimed for, 147  
 Steam jets, arrangement of, in boiler furnace, 147  
 Steam jet and boiler tube cleaning, 151  
 Steam jets, cooling of furnace bars, 147  
 Steam-jet draught, adjustable nozzle for, 148  
 Steam jets and furnace draught, 147  
 Steam jets and mechanical stokers, 122  
 Steam, latent heat of, 17  
 Steam pipes, arrangement of, 278  
 Steam pipes, drainage of, 278  
 Steam pipes, expansion bends in, 279  
 Steam pipes, expansion and contraction of, 279  
 Steam pipes, formula for loss of pressure in, 274  
 Steam pipes, inclination of, 278  
 Steam pipes, jointing of, 278  
 Steam pipes, jointing rings for, 280  
 Steam pipes, loss of heat by radiation from, 275  
 Steam pipes, pockets in, 278  
 Steam pipes, radiation from, 275  
 Steam pipes, ring-main system of, 279  
 Steam pipes, substance, are made of, 278  
 Steam pipes, support of, 279  
 Steam pipes, water hammer in, 275  
 Steam pressure, loss of in elbows, 275  
 Steam pressure, loss of in valves, 275  
 Steam pressures used in modern practice, 36  
 Steam pressures used thirty years ago, 36  
 Steam pressures, various, economy of condensing with, 367  
 Steam receivers with triple-expansion engines, 227  
 Steam reheating between cylinders, 224  
 Steam relief valves, 287  
 Steam saturated, 34  
 Steam saturated, properties of, 24  
 Steam separator, construction of, 203  
 Steam separator, Marriott, construction of, 203  
 Steam separator, Simms, 204  
 Steam service, connection of steam trap to, 280  
 Steamships, triple-expansion engines, 226  
 Steam, sizes of pipes for, 273  
 Steam storage in Cornish boilers, 58  
 Steam storage, Rateau's methods of, 324  
 Steam, superheating, 199  
 Steam superheating for condensation, 217  
 Steam trap, Anderson, operation of, 286  
 Steam trap, Brooke, construction of, 281  
 Steam traps, construction of, 280  
 Steam trap, Euston, construction of, 286  
 Steam trap, Euston, operation of, 286  
 Steam trap, Lancaster, construction of, 283  
 Steam trap, Lancaster, operation of, 283  
 Steam traps, lifting of water by, 281  
 Steam trap Midget, operation of, 285  
 Steam traps operated by volatile spirit, 285  
 Steam trap reservoir, construction of, 286  
 Steam trap reservoir, operation of, 286  
 Steam trap, Sirius, construction of, 282  
 Steam trap, Sirius, operation of, 282  
 Steam traps, use of, 280  
 Steam trap water seal, construction of, 284  
 Steam trap water seal, operation of, 284  
 Steam turbine action, 289  
 Steam turbine, balancing discs in, 295  
 Steam turbine, classes of, 288  
 Steam turbine, construction of, 288  
 Steam turbines, forms of buckets, 322  
 Steam turbines, forms of vanes, 322  
 Steam turbine, increased vacuum, increased efficiency, 37  
 Steam turbine, pressure, 288  
 Steam turbine reaction, 289  
 Steam turbine and reciprocating engine compared, 288  
 Steam turbine, velocity, 288  
 Steam valves worked from crank shaft, 262  
 Steam, velocity of, in Worthington jet condenser, 343  
 Steam, volume of, 34  
 Steam and water vapour, 34  
 Steel for boilers, testing, 61  
 Steel chimneys, construction of, 138  
 Steel chimneys, supporting, 138  
 Steel, tensile strength for boilers, 61  
 Stirling boiler, construction of, 84  
 Stirling boiler, course of hot gases, 84  
 Stirling boiler, drums of, 86  
 Stirling boiler, feed-water, 86  
 Stirling boiler, furnace of, 84  
 Stirling boiler, mud drum, 86  
 Stirling boiler, superheater, 86  
 Stirling superheater, 201  
 Stirling water-tube boiler, 84  
 Stirring and water softeners, 183  
 Stoker, chain grate, Babcock, 125  
 Stoker grate bars, movement of, 120  
 Stokers mechanical, 115  
 Stokers mechanical, chain grate, 124  
 Stokers mechanical, overfeed, 117  
 Stokers mechanical, underfeed, 125  
 Stoker mechanical, Wilkinson, 122  
 Stokers, overfeed, grate bars of, 120  
 Stop and safety valve combined, 156

- Stop valves, angle, 255  
 Stop valve body, construction of, 256  
 Stop valve, central pressure, operation of, 259  
 Stop valves, construction of, 242, 254  
 Stop valve, control of steam supply by, 243  
 Stop valves, globe, 255  
 Stop valves and governor, 255  
 Stop valve, Hopkinson-Ferranti, 257  
 Stop valves, operation of, 255  
 Stop valve, parallel slide, construction of, 256  
 Stop valve parallel slide, Hopkinson's, 256  
 Stop valve of steam engine, 242  
 Stop valves, warming, before opening, 243  
 Storage of exhaust steam for turbines, 324  
 Storage, steam, Rateau's methods of, 324  
 Strain on boiler shell with high pressures, 80  
 Straker boiler, construction of, 105  
 Straker boiler and motor waggons, 105  
 Straker boiler, use of, 105  
 Straw, calorific value of, 45  
 Specific heat of superheated steam, 35  
 Successive changes of heat, law of, 36  
 Suckling boiler, course of hot gases, 96  
 Suckling boiler, drums in, 96  
 Suckling boiler, water legs, 96  
 Suckling water-tube boiler, 96  
 Sulphate of calcium in water, 33  
 Sulphate of magnesium in water, 33  
 Sun, heat from, 2  
 Superheat, degree of, 200  
 Superheat required, quantity, 35  
 Superheated steam and lubrication, 231  
 Superheated steam, Siebel, 35  
 Superheated steam, specific heat, 35  
 Superheated steam and turbines, 328  
 Superheated steam in turbines, advantage of, 328  
 Superheated steam in turbines and lubrication, 328  
 Superheated steam, use of, 35  
 Superheater, Babcock, 200  
 Superheater in Babcock boiler, 83  
 Superheaters, construction of, 199  
 Superheater, Galloway, 203  
 Superheater, Nesdrum, 202  
 Superheater in Nesdrum boiler, 88  
 Superheaters, operation of, 200  
 Superheater, Schmidt's for Lancs. boiler, 202  
 Superheater separately fired for Lancashire boiler, 202  
 Superheater, Sinclair, 203  
 Superheater, Stirling, 201  
 Superheater, Stirling boiler, 86  
 Superheater, Tinker, construction of, 203  
 Superheater, Tinkers, fitted to Lancashire boiler, 201  
 Superheater, Woodeson boiler, 90  
 Superheating in Atlas boiler, 94  
 Superheating and pressure, 35  
 Superheating the steam, 199  
 Superheating steam for condensation, 217  
 Superheating and volume, 35  
 Superheating and watery vapour, 200  
 Supply of water for injector, 177  
 Surface condenser, air effect in, 332  
 Surface condenser, air pump for, 331  
 Surface condensers for the beds of streams, 338  
 Surface condenser, circulating pump for, 331  
 Surface condenser, construction of, 331  
 Surface condensers, double tubes in, 337  
 Surface condenser, enclosed, construction of, 331  
 Surface condenser, enclosed, course of steam in, 331  
 Surface condenser, evaporative, construction of, 344  
 Surface condensers, open tank, 338  
 Surface condenser, pumps for, 331  
 Surface condensers *versus* jet condensers, 341  
 Surface condenser, Wheeler, 336  
 Surface, cooling in condenser and I.H.P. 352
- T
- Table of flow of steam through pipes, 276, 277  
 Table of mean pressures, 216  
 Table of pressures for different fuels, Hutton, 130  
 Table of working capacity of steam with velocity, 290  
 Taking power from the piston, 260  
 Tandem compound, horizontal engine, 223  
 Tandem compound condensing engine horizontal, 224  
 Taylor water-tube boiler, 104  
 Temperature and pressure, 4  
 Temperature of the air with Ellis & Eaves apparatus, 145  
 Temperature at which bicarbonates split up, 33  
 Temperature of cylinder walls with expansive working, 217  
 Temperatures of combustion of towns refuse, 114  
 Temperature of feed with injector, 176  
 Temperature of gases in chimney with forced draught, 140

- Temperature gradient, definition of, 11  
 Temperature of hot gases in boiler furnace, 131  
 Temperature of hot gases in chimney, 129  
 Temperature, initial, and cooling water required, 351  
 Temperature limiting of hot gases in chimney, 129  
 Temperatures, measurement of, 5  
 Temperature by melting points of different substances, 6  
 Temperature of outside air and chimney draught, 134  
 Temperature, scales, 4  
 Temperature and specific heat, 14  
 Temperature of water delivered to economizer, 161  
 Temperature to which feed water can be heated with exhaust steam, 166  
 Temporary hardness in water, explanation of, 180  
 Tensile strength steel for boilers, 61  
 Tension of water vapour, 31  
 Testing steel for boilers, 61  
 Testing flue gases in chimney, 205  
 Tests of boiler furnaces, 65  
 Test of Curtis turbo generator, 313  
 Tests of De Laval turbines at different loads, 308  
 Tests of De Laval turbine pumps, 308  
 Thermal storage, Druitt Halpin, 327  
 Theory of heat, 1  
 Thermal conductivity, definition of, 11  
 Thermal conductivity of finely divided substances, 12  
 Thermal insulators, 11  
 Thermal insulators and air cells, 13  
 Thermal insulator, dry air, 12  
 Thermo-electric pyrometer, 7  
 Thermometer, domestic, 5  
 Thermometer, mercurial, 5  
 Thermometer, wet and dry bulb, use of, 28  
 Thomson's calorimeter, 44  
 Thornycroft boiler, launch type, 102  
 Thornycroft Marshall boiler, 100  
 Thornycroft motor wagon boilers, 105  
 Thornycroft-Schultz boiler, 100  
 Thornycroft boiler, "Speedy" type, 100  
 Thornycroft water-tube boiler, 99  
 Three-cylinder engines and cranks, 261  
 Throttle and expansion governing, difference between, 268  
 Tight side and loose side of belt, 263  
 Tinker superheater, fitted to Lancs. boiler, 201  
 Tinker superheater, construction of, 203  
 Towers, cooling, 370  
 Towers, cooling, chimney, 372  
 Towers, cooling, construction of, 379  
 Towers, cooling, without vertical draught, 371  
 Towns' refuse, burning, 113  
 Towns' refuse, burning, draught with, 114  
 Towns' refuse, calorific value of, 113  
 Towns' refuse destructors, construction of, 114  
 Towns' refuse, dust-settling apparatus, 114  
 Transmission of heat, 9  
 Transmitting power, De Laval turbine, 305  
 Transporting water-tube boilers, 81  
 Trap, steam connection of, to steam service, 280  
 Trap, steam, Brooke, construction of, 281  
 Trap, steam, water seal, construction of, 284  
 Traps, steam, use of, 280  
 Trays for water in jet condenser, 341  
 Treatment vessels in Harris-Anderson water softener, 192  
 Tripping gear for drop valves, 249  
 Triple expansion engines, 226  
 Triple expansion engines, arrangement of cylinders in, 226  
 Triple expansion condensing mill engine, horizontal, 240  
 Triple expansion engines, proportion of cylinders in, 226  
 Triple expansion engine receivers, steam, 227  
 Triple expansion engine, Willans, 234  
 Trip valve, 242  
 Tubes, arrangement of, Woodeson boiler, 90  
 Tubes, capacity in Green's economizer, 160  
 Tubes in Nesdrum boiler, 87  
 Tubes in Thornycroft Marshall boiler, 100  
 Tubes in Wheeler surface condenser, 337  
 Tubes in Wood boiler, 92  
 Turbine, admission of steam to intermediate sections, 295  
 Turbine, A.E.G., course of steam in, 316  
 Turbine blades, Parsons, 294  
 Turbine boiler tube cleaners, 151  
 Turbines and condensing, 327  
 Turbine, Curtis; construction of, 309  
 Turbine, De Laval, highest efficiency speed, 302  
 Turbine, early duplicate, Parsons, 294  
 Turbine, end thrust in, 294  
 Turbine governor relay valve, Parsons, 297  
 Turbine governor, Willans, 300  
 Turbine, Hamilton Holzwarth, construction of, 321  
 Turbines, intermediate, 289  
 Turbine, length of, 294  
 Turbines, Parsons, bearings of, 295

Turbine, Parsons, construction of, 292  
 Turbines, pressure and impulse, difference between, 291  
 Turbines, pressure, compounding in, 292  
 Turbine pumps, De Laval, tests of, 308  
 Turbine, Rateau, diaphragms in, 316  
 Turbine, steam, balancing discs in, 295  
 Turbines, steam, forms of buckets, 382  
 Turbines and superheated steam, 328  
 Turbines, vacuum with, 332  
 Turbine, Westinghouse, construction of, 313  
 Turbine, Willans Parsons, construction of, 292  
 Turbines working with exhaust steam, 322  
 Turbine, Zoelly, construction of, 317  
 Turbine, Zoelly, governor of, 320  
 Turbo pump, Parsons, 298  
 Turner-Miesse motor boiler, 106  
 Twin-cylinder engines, arrangement of, 239  
 Two-stage dry air pumps, 365

## U

Ultimate analysis of fuel, 43  
 Ultra violet rays, 3  
 Underfeed mechanical stokers, 125  
 Underfeed mechanical stoker, Erith, 126  
 Underfeed Stoker Co.'s mechanical stoker, 126  
 Unit of heat absolute, 14  
 Unit of mechanical work explained, 15  
 Use of blast furnace gas, 50  
 Use of condenser, 330  
 Use of cooling water for boiler feed, 338  
 Use of the crank shaft, 260  
 Use of hot gases to heat feed water, 156  
 Use of propeller fan, 145  
 Use of reducing valve, 259  
 Use of steam traps, 280  
 Use of stop valve in driving alternating current generators, 243  
 Use of Straker boiler, 105  
 Use of superheated steam, 35  
 Uses of small vertical boilers, 104

## V

Vacua, different, cooling water required with, Richard Allen, 356  
 Vacua, high, and cooling water, 351  
 Vacuum augmenter, advantage of, 347  
 Vacuum augmenter, consumption of steam in, 348  
 Vacuum augmenter, operation of, 348  
 Vacuum augmenter, Parsons, 347

Vacuum in inches and pounds, 332  
 Vacuum oil separator, Cochrane, 195  
 Vacuum with reciprocating engines, 327, 332  
 Vacuum with turbines, 327, 332  
 Valve, Corliss, 242  
 Valve, Corliss, description of, 251  
 Valve, Corliss, operation of, 251  
 Valve, Corliss, wrist plate of, 252  
 Valve, Cornish, 242  
 Valves, Cornish, description of, 250  
 Valves, distributing, of high-speed engines, 231  
 Valve, drop, 242, 249  
 Valves, loss of steam pressure in, 275  
 Valve motion, range of, Peache engine, 239  
 Valves, operation of, Peache engine, 238  
 Valves of Peache engine, 237  
 Valves, reciprocating for engines, 242  
 Valves, relief, steam, 287  
 Valve, slide, 242  
 Valve, slide, piston, 248  
 Valve, stop, construction of, 254  
 Valve, stop, Hopkinson-Ferranti, 257  
 Valves, stop, operation of, 255  
 Valve, trip, 242  
 Valve, Wheelock, construction of, 253  
 Vanes of steam turbines, forms of, 322  
 Vapour in atmosphere and barometer indications, 19  
 Vapour distribution chambers in Contraflo condenser, 339  
 Vapour from surface of water, pressure of, 19  
 Vapour, water and steam, 34  
 Variable-stroke plunger pumps, 365  
 Variations of arrangement of tubes, water-tube boilers, 79  
 Variation of the boiling-point, 18  
 Variation of evaporation with weather, 369  
 Variation in pressure of the atmosphere, 19  
 Variation of pressure and latent heat, 22  
 Variation of speed of circulating pump for condenser, 363  
 Various substances, specific heats of, 13  
 Velocity of circulating water, Prof. Weighton, 362  
 Velocity of cooling water in condenser, 352  
 Velocity of gases and height of chimney, 133  
 Velocity of steam impinging on De Laval turbine disc, 302  
 Velocity of steam, increase of, in De Laval turbine, 301  
 Velocity of steam, increase of, with lowered pressure, 291

- Velocity of steam in pipes, 274  
 Velocity of steam in Worthington jet condenser, 343  
 Velocity steam turbine, 288  
 Velocity turbine, steam expansion for, 290  
 Ventilation by furnace in mines, 127  
 Vertical boiler and horizontal engine, 223  
 Vertical boilers, small, 104  
 Vertical compound engines, arrangement of, 239  
 Vertical engine unenclosed, compound, 225  
 Vertical and horizontal engines, 239  
 Vickers' mechanical stoker, construction of, 123  
 Vickers stoker, feed of, 124  
 Vickers stoker, movement of fire bars, 123  
 Vickers stoker for water-tube boilers, 124  
 Volatile matter in coals, 42  
 Volatile spirit, operating steam traps, 285  
 Volume of gases with induced draught, 142  
 Volume of gases produced by combustion, 130  
 Volume of gases and width of fan, 146  
 Volume and pressure, 29  
 Volume and pressure of gas, formula for, 239  
 Volume of steam, 34  
 Volume and superheating, 35  
 Volume and weight of air at various temperatures, 26
- W
- Wainwright corrugated tube, 166  
 Wainwright's heating curves with plain and corrugated tubes, 167  
 Wall pumps, arrangement of, 173  
 Wall pump, Pearn, 173  
 Wall steam engine, 222  
 Warming steam cylinders on starting up, 243  
 Warming stop valves before opening, 243  
 Waste of heat in domestic fire grate, 54  
 Waste of heat in steam feed pumps, 172  
 Water-bearing strata, 32  
 Water below furnace in Lancs. boilers, 59  
 Water and carbonates, 33  
 Water and chlorides, 33  
 Water circulation, Climax boiler, 99  
 Water circulation in Nesdrum boiler, 88  
 Water, composition of, 31  
 Water for condensing, cost of, 368  
 Water cooling, 333  
 Water cooling, heat absorbed by, 333  
 Water in Cornish boilers, 58  
 Water, course of, in evaporative condenser, 334  
 Water, course of water in enclosed surface condenser, 331  
 Water to be employed for feed, 179  
 Water employed for feed, course of, 169  
 Water, evaporation of, 31  
 Water, evaporation, cooling effect of, 335  
 Water, expansion of, 16  
 Water, expansion in freezing, 16  
 Water- and fire-tube boilers, difference between, 77  
 Water and gases, course of in economizer, 160  
 Water in the gaseous state, 31  
 Water gauge, boiler, construction of, 151  
 Water gauge, construction of, 129  
 Water gauge, explanation of, 129  
 Water gauge 1-inch pressure, corresponding to, 129  
 Water hammer in steam engines, 275  
 Water hammer in steam pipes, 275  
 Water jet in Worthington jet condenser, 342  
 Water in Lancs. boilers, 58  
 Water, latent heat of, 17  
 Water legs in Marshall's boiler, 91  
 Water legs in Suckling boiler, 96  
 Water in the liquid state, 31  
 Water lost by evaporation, 335  
 Water, oil, removing from, 193  
 Water in pockets, action of steam on, 278  
 Water purifying apparatus of Atlas boiler, 95  
 Water and reagents, course of in Harris-Anderson apparatus, 193  
 Water safety apparatus, 155  
 Water seal steam trap, construction of, 284  
 Water seal steam trap, operation of, 284  
 Water softener, Archbutt-Deely, 183  
 Water softener, Bruun-Lowener, construction of, 187  
 Water softeners, construction of, 182  
 Water softener, Criton, construction of, 184  
 Water softener, Desrumaux, construction of, 190  
 Water softener, Doulton, construction of, 188  
 Water softeners and filters, 183  
 Water softener, Guttman, construction of, 188  
 Water softener, Harris-Amderson, construction of, 192  
 Water softeners, importance of mixing reagents, 182

- Water softener, Kennicott, construction of, 189
- Water softener, Arthur Koppel, construction of, 191
- Water softener for locomotive boilers, Reisert, 187
- Water softener, Reisert, construction of, 186
- Water softeners and stirring, 183
- Water softening and analysis, 182
- Water in the solid state, 31
- Water and sulphates, 33
- Water surface in Cornish boiler, 60
- Water surface in Lancs. boiler, 60
- Water tanks on chimneys, 138
- Water, temperature of, delivered to economizer, 161
- Water trays in jet condenser, 341
- Water tubes of Climax boiler, 98
- Water-tube boilers, advantage with high pressures, 79
- Water-tube boilers, ashpits in, 82, 107
- Water-tube boiler, Atlas, 93
- Water-tube boiler, Babcock, 82
- Water-tube boilers, brickwork, 78
- Water-tube boilers, circulation, 81
- Water-tube boiler, Climax, 98
- Water-tube boilers, construction of, 77
- Water-tube boiler, Davey-Paxman, construction of, 91
- Water-tube boiler, Detroit, 95
- Water-tube boilers, fire bars, 82
- Water-tube boilers, furnace of, 82
- Water-tube boilers, furnace grates, 107
- Water-tube boiler, Galloway, 93
- Water-tube boiler, Heine, 95
- Water-tube boilers with horizontal tubes, 90
- Water-tube boilers, iron work for, 78
- Water-tube boilers, largest diameters of vessels in, 81
- Water-tube boiler, Marshall, 91
- Water-tube boiler, Nesdrum, 87
- Water-tube boiler, Sinclair, 96
- Water-tube boiler, Stirling, 84
- Water-tube boiler, Suckling, construction of, 96
- Water-tube boiler, Taylor, 104
- Water-tube boiler, Thornycroft, 99
- Water-tube boilers, transporting, 81
- Water-tube boilers, various arrangements of tubes, 79
- Water-tube boilers, Vickers stoker, 124
- Water-tube boiler, Wood, 92
- Water-tube boiler, Woodeson, 88
- Water-tube boilers, working of, 79
- Water vapour and air, 25
- Water vapour in air and blast furnaces, 27
- Water vapour in air in different months, 27
- Water vapour in atmosphere, 18
- Water vapour, condensation of, 34
- Water vapour and cylinder condensation, 217
- Water vapour, elastic force of, 27
- Water vapour and expansive working, 217
- Water vapour and steam, 34
- Water vapour, tension of, 31
- Water from wells, 32
- Water, where it comes from, 31
- Watery vapour and superheating, 200
- Wave theory of heat, 1
- Waves, characteristics of, 1
- Weight of air, 18
- Weight of column of air above the earth, 18
- Weight of petroleum, 47
- Weight and volume of air at various temperatures, 26
- Weighton, Prof., experiments on condensers, 360
- Weir's evaporators, 205
- Wells for water, 32
- Westinghouse turbine, construction of, 313
- Westinghouse turbine, course of steam in, 315
- Westinghouse turbine on Metropolitan District Railway, 313
- Wet back boiler, 74
- Wet and dry bulb thermometer, use of, 28
- Wheeler combined condenser and pump plant, 337
- Wheeler surface condenser, tubes in, 337
- Wheelock expansion gear for mill engines, 241
- Wheelock valve, construction of, 253
- Wheelock valve, description of, 242
- White boiler, construction of, 106
- White light, composition of, 2
- White motor-waggon boiler, 106
- Width of fan for mechanical draught, 146
- Wilkinson mechanical stoker, 122
- Willans central valve engine, 232
- Willans engine, air cylinder, 233
- Willans engine, arrangement of cranks, 233
- Willans engine, arrangement of cylinders in, 232
- Willans engine, arrangement of cylinders, compound, 234
- Willans engine, brasses in compression, 233
- Willans engine, compressed air, heat in, 234
- Willans engine, course of steam, 233
- Willans engine, distributing valve, 232
- Willans engine, governor of, 235
- Willans engine relief valves, 235

- Willans engine, single acting, 233  
 Willans engine, steam distribution, 232  
 Willans engine, work in compressing air, 234  
 Willans-Parsons turbine, construction of, 292  
 Willans triple-expansion engine, arrangement of, 234  
 Willans turbine blades, construction of, 293  
 Willans turbine governor, 300  
 Willans turbine, lubrication of, 300  
 Willans turbine, secondary governor, 300  
 Williams feed-water regulator, construction of, 179  
 Wilson Hartnell's expansion governor, 267  
 Wires used in thermo-electric pyrometer, 7  
 Wood boiler, construction of, 92  
 Wood boiler, course of hot gases in, 93  
 Wood boilers, headers in, 92  
 Wood boiler, tubes in, 92  
 Wood, calorific value of, 45  
 Wood, composition of, 44  
 Wood for cooling towers, 379  
 Wood, measurement of, 45  
 Wood water-tube boiler, 92  
 Wood wool filter in Bruun Lowener water softener, 188  
 Wooden cores in condenser tubes, 360  
 Wooden gratings in cooling towers, 377  
 Woodeson boiler, arrangement of tubes, 90  
 Woodeson boiler, construction of, 88  
 Woodeson boiler, furnace of, 88  
 Woodeson boiler, mud drums, 90  
 Woodeson boiler, superheater, 90  
 Woodeson water-tube boiler, 88  
 Work in compressing air, Willans engine, 234  
 Work steam engine will perform, 218  
 Working pressure in steam engines, 215  
 Working of water-tube boilers, 79  
 Worm gearing, arrangement of, 265  
 Worm gearing, efficiency of, 265  
 Worthington boiler feed pump, construction of, 171  
 Worthington Co.'s cooling tower, 377  
 Worthington jet condenser, water jet in, 342  
 Wrist plate of Corliss valve, 252  
 Weinland boiler tube cleaner, 150  
 Weinland turbine boiler tube cleaner, 151

## Z

- Zoelly turbine, bearings in, 319  
 Zoelly turbine, clearance in, 319  
 Zoelly turbine, construction of, 317  
 Zoelly turbine, emergency governor in, 320  
 Zoelly turbine and exhaust steam, 329  
 Zoelly turbine, governor of, 320  
 Zoelly turbine governor, oil relay in, 320  
 Zoelly turbine, overload valve in, 321  
 Zoelly turbine, runners in, 319

THE END



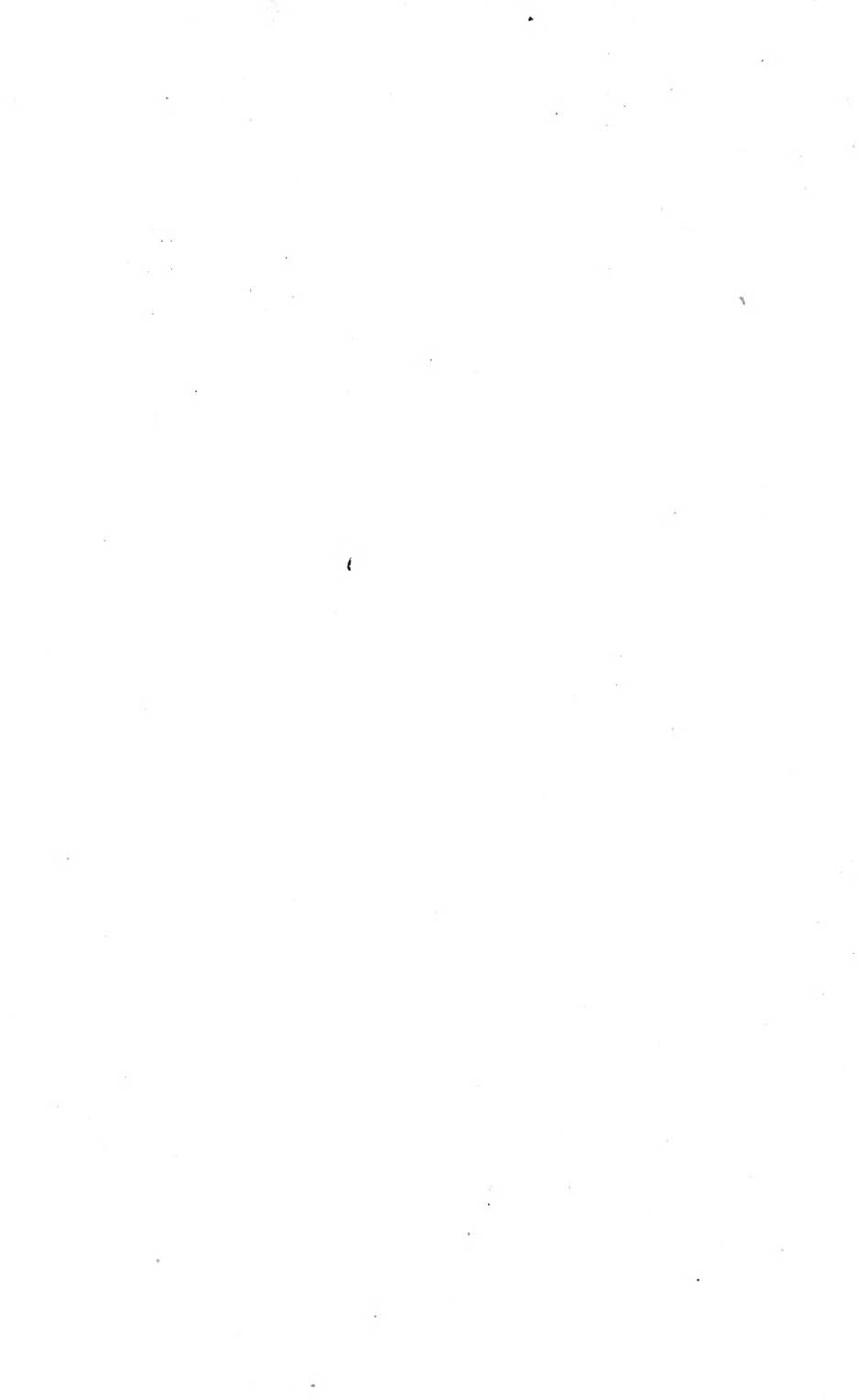

THIS BOOK IS DUE ON THE LAST DATE  
STAMPED BELOW

AN INITIAL FINE OF 25 CENTS  
WILL BE ASSESSED FOR FAILURE TO RETURN  
THIS BOOK ON THE DATE DUE. THE PENALTY  
WILL INCREASE TO 50 CENTS ON THE FOURTH  
DAY AND TO \$1.00 ON THE SEVENTH DAY  
OVERDUE.

OCT 22 1943

OCT 23 1943

Dec 29 '49 RF

APR 24 1967 7 6

RECEIVED

APR 24 '67 - 3 P 1

LOAN DEPT.

AUG 2 1967 1

RECEIVED

SEP 8 '67 - 2 PM

FEB 17 1970

REC'D LD FEB 3 '70 - 2 PM

K9

LD 21-100m-7,'89(402s)

post w  
ues      ues



TJZ75  
W2

181025

Walker

