

**STEAM-ENGINE
PRINCIPLES AND PRACTICE**
TERRELL CROFT, EDITOR

CONTRIBUTORS

The following have contributed manuscript or data or
have otherwise assisted in the preparation of this work:

EDMUND SIROKY
H. C. CROFT A. J. DIXON E. R. POWELL
Terrell Croft Engineering Company

BOOKS BY
TERRELL CROFT

PUBLISHED BY

McGRAW-HILL BOOK COMPANY, INC.

THE AMERICAN ELECTRICIAN'S HANDBOOK,
Flexible Leather, $7 \times 4\frac{1}{4}$, 823 Pages, 897
Illustrations.

WIRING OF FINISHED BUILDINGS,
Cloth, $8 \times 5\frac{1}{2}$, 275 Pages, 234 *Illustrations.*

WIRING FOR LIGHT AND POWER,
Flexible Cover, Pocket Size, 507 Pages,
428 *Illustrations.*

ELECTRICAL MACHINERY,
Cloth, $8 \times 5\frac{1}{2}$, 318 Pages, 304 *Illustrations.*

PRACTICAL ELECTRIC ILLUMINATION,
Cloth, $8 \times 5\frac{1}{2}$, 225 Pages, 170 *Illustrations.*

PRACTICAL ELECTRICITY,
Cloth, $8 \times 5\frac{1}{2}$, 646 Pages, 583 *Illustrations.*

CENTRAL STATIONS,
Cloth, $8 \times 5\frac{1}{2}$, 332 Pages, 310 *Illustrations.*

STEAM BOILERS,
Cloth, $8 \times 5\frac{1}{2}$, 412 Pages, 518 *Illustrations.*

STEAM POWER PLANT AUXILIARIES AND ACCESSORIES,
Cloth, $8 \times 5\frac{1}{2}$, 447 Pages, 411 *Illustrations.*

STEAM ENGINE PRINCIPLES AND PRACTICE,
Cloth, $8 \times 5\frac{1}{2}$, 495 Pages, 548 *Illustrations.*

OFFICE OF
THE ATTORNEY GENERAL

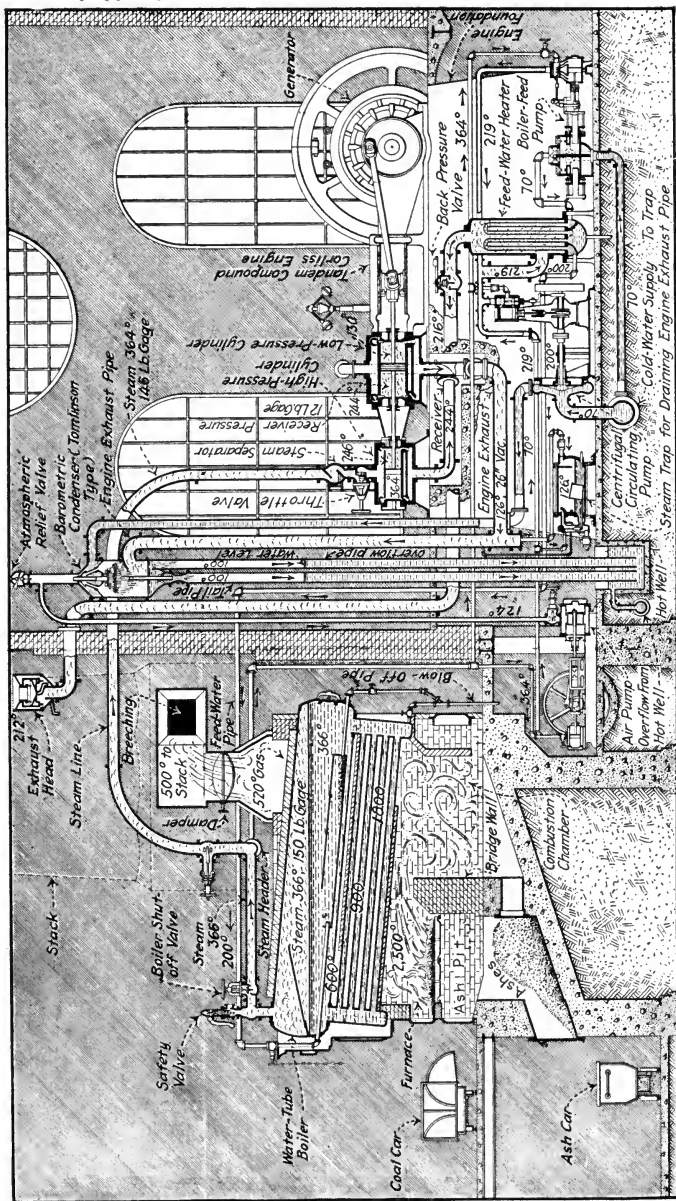

Frontispiece.—Temperature variations through a boiler and engine. (Sectional view of the apparatus and piping of a typical reciprocating engine plant, operating condensing, showing the variation of temperature of the boiler gases and variation of the temperature and pressure of the steam during the course from the boiler through the engine and auxiliaries and back to the boiler. This is intended to show temperatures rather than a recommended arrangement and design of a power plant. Based on a supplement to *Power*, Feb. 17, 1914.)

STEAM-ENGINE PRINCIPLES AND PRACTICE

TERRELL CROFT, EDITOR

CONSULTING ENGINEER. DIRECTING ENGINEER, TERRELL CROFT ENGINEERING CO.
MEMBER OF THE AMERICAN SOCIETY OF MECHANICAL ENGINEERS.
MEMBER OF AMERICAN INSTITUTE OF ELECTRICAL ENGINEERS.
MEMBER OF THE ILLUMINATING ENGINEERING SOCIETY.
MEMBER AMERICAN SOCIETY TESTING MATERIALS.

FIRST EDITION
FIRST IMPRESSION

McGRAW-HILL BOOK COMPANY, Inc.
NEW YORK: 370 SEVENTH AVENUE
LONDON: 6 & 8 BOUVERIE ST., E. C. 4

1922

TO THE
ADMINISTRATOR

TJ 465
C7

Engineering
Library

COPYRIGHT, 1922, BY TERRELL CROFT

Mechanics Dept.

PREFACE

STEAM-ENGINE PRINCIPLES AND PRACTICE has been very carefully prepared to satisfy what is thought to have been a long-felt need for a "practical" book which would contain the information that an operating engineer or a plant superintendent requires concerning steam engines. Although there exists a popular impression that, since the advent of the steam turbine, the steam engine is no longer of any consequence in the generation of mechanical energy (power), nothing could be more erroneous. Under certain conditions, the steam engine is still—and probably always will be—a very desirable and economical prime mover.

No attempt has been made to include in this book anything which pertains to the design of steam engines. The treatment has been directed toward what may be termed the "use" of the engines. That is, the aim has been to supply such information as will enable the reader to wisely select, operate, care for, and repair steam engines and to make a study of and where possible to improve their economy. No "higher mathematics" is employed; a working knowledge of arithmetic should enable one to understand all which is presented.

Drawings for all of the 548 illustrations were made especially for this work. It has been the endeavor to so design and render these pictures that they will convey the desired information with a minimum of supplementary discussion.

Throughout the text, principles which are presented are explained with descriptive expositions or with worked-out arithmetical examples. Also, at the end of each of the 16 divisions there are questions to be answered and, where justified, problems to be solved by the reader. These questions and problems are based on the text matter in the division just preceding. If the reader can answer the questions and solve the problems, he then must be conversant with the subject matter of the division. Detail solutions to all of the problems are printed in an appendix in the back of the book.

As to the general order of treatment:—First the function and principle of the steam engine are considered. These are

followed by a division on nomenclature and classification. Next follows a treatment of indicators and their many uses. Then the two most important functioning parts of the engine—the valves and the governor—are fully treated under the division titles of: slide valves and their adjustment, Corliss and poppet valves and their adjustment, fly-ball steam-engine governors, and shaft steam-engine governors.

The economics of the use of condensers with steam engines and of employing multi-expansion engines are next considered and are followed by a division on steam-engine efficiencies and how to increase them. The material in the next division, on steam engines of modern types, concerns the distinctive features, economics and costs of engines of the present day. The testing of steam engines is then treated. Following this are divisions on the management, operation and repair of reciprocating engines and on the use of superheated steam in engines which, it is hoped, will be of great value to the engineer.

Next, the selection of steam engines is discussed from a purely but broadly economic standpoint. Finally, a thorough treatment of lubrication is presented which, although it relates specifically to steam engines, should prove of general value also as it applies to other machinery.

With this, as with the other books which have been prepared by the editor, it is the sincere desire to render it of maximum usefulness to the reader. It is the intention to improve the book each time it is revised and to enlarge it as conditions may demand. If these things are to be accomplished most effectively, it is essential that the readers cooperate with us. This they may do by advising the editor of alterations which they feel it would be desirable to make. Future revisions and additions will, insofar as is feasible, be based on such suggestions and criticisms from the readers.

Although the proofs have been read and checked very carefully, it is possible that some undiscovered errors may remain. Readers will confer a decided favor in advising the editor of any such.

TERRELL CROFT.

UNIVERSITY CITY,
ST. LOUIS, MO.,
July, 1922.

ACKNOWLEDGMENTS

The editor desires to acknowledge the assistance which has been rendered by various engine manufacturers of the United States. Among them are the: *Allis-Chalmers Manufacturing Company; Ames Iron Works; Chuse Engine and Manufacturing Company; C. & G. Cooper Company; Erie Ball Engine Company; Erie City Iron Works; Fulton Iron Works; Harrisburg Foundry and Machine Works; Nordberg Manufacturing Company; Ridgway Dynamo and Engine Company; Vilter Manufacturing Company.*

Furthermore, certain of the text material appeared originally as articles in certain trade and technical periodicals among which are: *National Engineer, Power, Power Plant Engineering and Southern Engineer.*

Numerical values for tables and graphs have, in certain instances, been taken from engineering textbooks of recognized high standing. In such cases acknowledgment is made at the places in the text where the values are used.

Special acknowledgment is hereby accorded Edmond Siroky, Head Mechanical Engineer of The Terrell Croft Engineering Company, who has been responsible for the technical accuracy of the book.

Other acknowledgments have been made throughout the book. If any has been omitted, it has been through oversight and, if brought to the author's attention, it will be incorporated in the next edition.

TERRELL CROFT.

CONTENTS

STEAM-ENGINE PRINCIPLES AND PRACTICE

BY

TERRELL CROFT

	PAGE
FRONTISPIECE	iv
PREFACE.	vii
ACKNOWLEDGMENTS	ix
LIST OF SYMBOLS	xii
DIVISION 1.—FUNCTION AND PRINCIPLE OF THE STEAM ENGINE.	1
DIVISION 2.—STEAM-ENGINE MECHANISMS AND NOMENCLATURE	19
DIVISION 3.—STEAM-ENGINE INDICATORS AND INDICATOR PRACTICE	40
DIVISION 4.—SLIDE VALVES AND THEIR SETTING	84
DIVISION 5.—CORLISS AND POPPET VALVES AND THEIR SETTING	146
DIVISION 6.—FLY-BALL STEAM-ENGINE GOVERNORS, PRINCIPLES AND ADJUSTMENT	192
DIVISION 7.—SHAFT STEAM-ENGINE GOVERNORS, PRINCIPLES AND ADJUSTMENT.	228
DIVISION 8.—COMPOUND AND MULTI-EXPANSION ENGINES	258
DIVISION 9.—CONDENSING AND NON-CONDENSING OPERATION.	283
DIVISION 10.—STEAM-ENGINE EFFICIENCIES AND HOW TO INCREASE THEM.	291
DIVISION 11.—STEAM ENGINES OF MODERN TYPES.	319
DIVISION 12.—STEAM-ENGINE TESTING	342
DIVISION 13.—RECIPROCATING-ENGINE MANAGEMENT, OPERATION, AND REPAIR.	373
DIVISION 14.—USE OF SUPERHEATED STEAM IN ENGINES	417
DIVISION 15.—SELECTING AN ENGINE	427
DIVISION 16.—STEAM-ENGINE LUBRICATION	447
SOLUTIONS TO PROBLEMS.	488
INDEX	497

STEAM ENGINE PRINCIPLES AND PRACTICE

LIST OF SYMBOLS

The following list comprises practically all of the symbols which are used in formulas in this book. Symbols which are not given in this list are defined in the text where they are first used. When any symbol is used with a meaning different from that specified below, the correct meaning is stated in the text where the symbol occurs.

SYMBOL	MEANING	SECTION FIRST USED
A_{ip}	Area of piston, exclusive of area of rod, in square inches.	17
C_m	Mean specific heat of superheated steam.	317
D_{ps}	Density of steam, in pounds per cubic foot.	129
d_i	Diameter, in inches.	360
E	Voltage or electromotive force, in volts.	361
E_d	Efficiency, expressed decimally.	362
E_{dm}	Mechanical efficiency, expressed decimally.	321
E_{dt}	Thermal efficiency of ideal Rankine cycle, expressed decimally .	315
E_{dib}	Thermal efficiency based on brake horse power, expressed decimally.	322
E_{diti}	Thermal efficiency based on indicated horse power, expressed decimally.	317
F_c	Centrifugal force, in pounds.	222
H_d	Total heat of dry saturated steam, in B.t.u. per pound.	317
H_l	Heat of liquid, in B.t.u. per pound.	315
H_t	Total heat of steam, in B.t.u. per pound.	315
H_v	Latent heat of vaporization, in B.t.u. per pound.	317
I	Current, in amperes.	361
K	A constant.	19
k	Horse power constant.	121
k_b	Brake constant.	380
L_f	Effective length of brake arm, in feet.	357
L_{fs}	Length of stroke, in feet.	17
L_{hi}	Height, in inches.	224
M_r	Regulation coefficient, expressed decimally.	219
N	Angular speed, in revolutions per minute.	18
N_f	Engine speed at full load, in revolutions per minute.	219
N_n	Engine speed at no load, in revolutions per minute.	219
N_s	Number of double strokes per minute.	18
π	3.1416	357
P_a	Pressure, in pounds per square inch absolute.	19
P_g	Pressure, in pounds per square inch gage.	19

SYMBOL	MEANING	SECTION FIRST USED
P_m	Mean effective pressure, in pounds per square inch.....	17
P	Power developed in one end of a cylinder, in foot pounds per minute.....	18
P_{bhp}	Brake horse power.....	321
P_{hp}	Power, in horse power.....	360
P_{ihp}	Power developed in one end of a cylinder, in horse power.....	18
P_{ihp}	Total indicated horse power of an engine.....	321
P_{kw}	Power, in kilowatts.....	361
r_i	Radius, in inches.....	222
T_f	Temperature, in degrees Fahrenheit.....	371
T_n	Superheat, in degrees Fahrenheit.....	317
t_h	Time, in hours.....	373
t_s	Time, in seconds.....	379
V_i	Volume, in cubic inches.....	379
W	Work done in one end of a cylinder per double stroke, in foot pounds.....	17
W	Weight, in pounds.....	222
W_{ih}	Weight of steam used in one end of a cylinder per indicated horse power hour, in pounds.....	129
W_s	Weight of steam used per horse power hour, in pounds.....	316
W_{sb}	Weight of steam used per brake horse power hour, in pounds.	322
W_{sd}	Weight of dry steam, in pounds.....	372
W_{sdb}	Weight of dry steam per brake horse power hour, in pounds..	373
W_{sdi}	Weight of dry steam per indicated horse power hour, in pounds.	373
W_{si}	Weight of steam per indicated horse power hour, in pounds..	317
W_{sw}	Weight of wet steam, in pounds.....	372
x_c	Clearance volume expressed as a fraction of piston displacement	130
x_d	Quality of steam, expressed decimally.....	317
x_p	Quality of steam, in per cent.....	371
x_s	Fraction of stroke.....	129



STEAM ENGINE

PRINCIPLES AND PRACTICE

DIVISION 1

FUNCTION AND PRINCIPLE OF THE STEAM ENGINE

1. **The Function Of The Steam Engine** is to convert heat energy into mechanical work. The heat energy is evolved by the combustion of a fuel within a furnace which is so arranged that the heat will be transferred to water within an adjacent boiler. The water is thus converted into steam which is then conducted to the engine. Within the engine the steam is compelled to do mechanical work and, in so doing, loses a portion of its stock of heat energy. The mechanical work is transmitted from the engine to the place where it may be useful by means of belts, ropes, chains, or other connectors. Or, it may be converted into electrical energy and transmitted through wires.

NOTE.—THE HEAT-FLOW IN A STEAM-ENGINE PLANT is illustrated in the frontispiece. Coal is burned within the furnace producing a large volume of hot gases (2,500 deg. fahr.). The path of these gases is so restricted that they must impinge upon the surfaces of tubes of the boiler. These tubes contain water which is, by the burning coal, maintained at a temperature of approximately 366 deg. fahr. Heat flows from the hot gases to the water within the tubes. The temperature of the gases is thus reduced so rapidly that they leave the boiler at about 520 deg. fahr. The heat, which is given to the water, evaporates it into steam at 366 deg. fahr. The steam flows to the engine through pipes, wherein some heat is lost, and reaches the compound engine at a temperature of 364 deg. fahr. In the high-pressure cylinder the steam does work, loses heat energy and then leaves the cylinder at a temperature of 246 deg. fahr. It is then conducted to the low-pressure cylinder where it again does work and loses heat. It is finally rejected from the engine at a temperature of 130 deg. fahr. What is then done with the steam does not affect the

operation of the engine but rather the efficiency of the plant as a whole. The efficiency of the engine in performing its function will be discussed in Div. 10.

2. The Construction Of The Elementary Steam Engine can be understood by a study of Fig. 1 (see also Div. 2). Essentially, the important parts of the engine are the valve, *V*, cylinder, *C*, piston, *P*, frame, *F*; and the moving parts whereby the motion of the piston is transmitted to some other

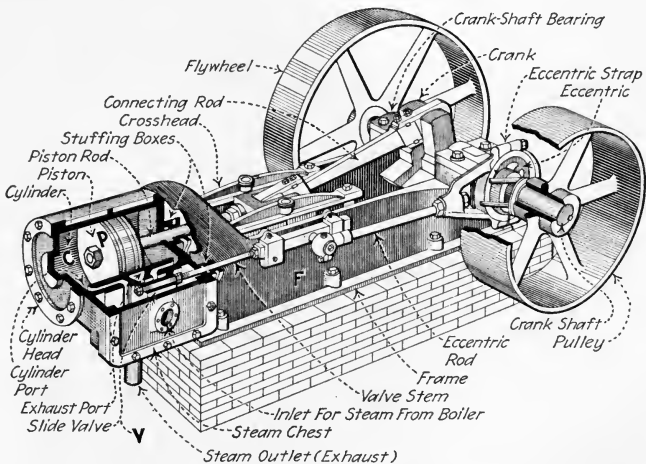

FIG. 1.—A typical simple slide-valve engine.

machine and whereby the proper motions are given to the valve. The valve opens passages through which steam may flow into the cylinder from the boiler or out of the cylinder into the atmosphere. (The spent or exhaust steam may, if desirable, be led, instead of into the atmosphere, into a condenser or into a heater.) The steam, when thus admitted into the cylinder, exerts a pressure or pushes against the piston which fits closely within the cylinder. The steam is thus capable of moving the piston against some resistance—or, in other words, the steam is capable of doing work upon the piston.

3. "Clearance" Or "Clearance Volume" are terms which should be understood before the reader proceeds. *Clearance*

applies to the space between the piston and the end of the cylinder, together with the steam passages as far as the valves, when the piston is at one extreme end of its travel. Since it is mechanically unsafe to attempt the construction of an engine without some clearance, all actual engines are built with a certain amount of clearance. Only engines with clearance will be considered in this book. Clearance is usually expressed as a percentage of the volume (displacement volume) through which the piston sweeps. The *displacement volume* = *area of piston* \times *length of stroke*.

EXAMPLE.—An 18 in. by 30 in. engine (Fig. 2) has clearance volumes of (1) head end—141.3 cu. in. (2) crank end—139. cu. in. If the piston rod is 2 in. in diameter what are the clearances in per cent. of displacement volume? SOLUTION.—The *head-end displacement volume* = $(18 \times 18 \times 0.785) \times 30 = 7620$ cu. in. The *crank-end displacement volume* = $7620 - (2 \times 2 \times 0.785 \times 30) = 7526$ cu. in. Thus, the *head-end clearance* = $141.3 \div 7620 = 0.0186$ or 1.86 per cent. Also, the *crank-end clearance* = $139 \div 7526 = 0.0185$ or 1.85 per cent.

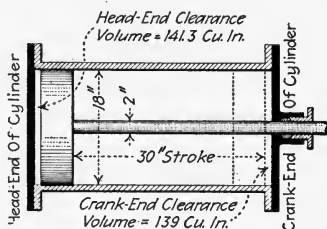

FIG. 2.—What are the clearances in percentages of piston displacement?

NOTE.—“PISTON CLEARANCE” OR “LINEAL CLEARANCE” refers only to the distance between the piston and the end of the cylinder (the *cylinder head*) when the piston is at that end of its travel. Piston clearance is measured in linear inches.

4. The Operation Of The Elementary Steam Engine (Figs. 3 and 4) can thus be explained:

EXPLANATION.—Consider an engine (Fig. 3) which is equipped with two hand-operated valves V_1 and V_2 . When the valve levers are held in the position shown in Fig. 3, valve V_2 will permit steam to flow into the cylinder at the right-hand side of the piston. Valve V_1 , however, is in such position as to allow the escape of whatever steam or air may be at the left-hand side of the piston. Therefore, the pressure of the steam acting on the piston will force the piston to the left. After the piston has traveled as far as the connecting rod and shaft will permit, the operator shifts the levers to the positions of Fig. 4. This, since it permits steam to flow into the cylinder through V_1 and out through V_2 , will reverse the force on the piston and drive it to the right. If the valves are shifted

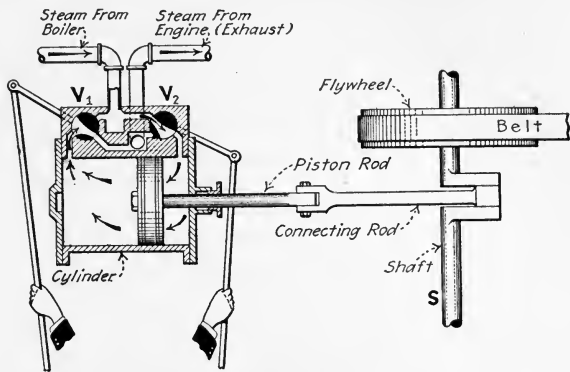

FIG. 3.—Section through cylinder of engine with hand-operated valves.

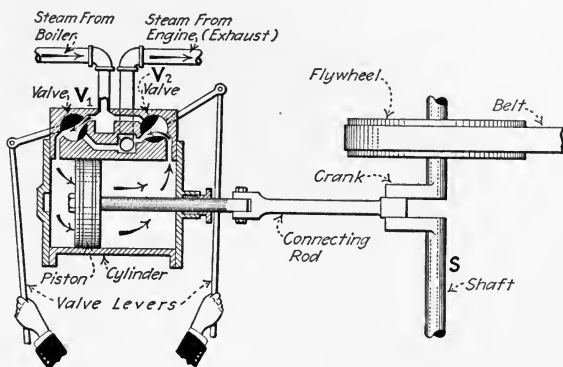

FIG. 4.—Section through cylinder of engine with hand-operated valves. (This is the same engine as shown in Fig. 3 but with the valves so shifted as to cause the piston to move in the opposite direction.)

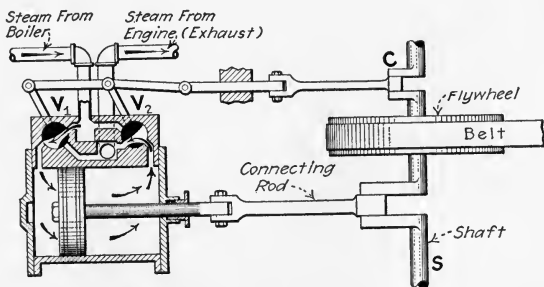

FIG. 5.—Section through cylinder of engine with automatic valves. (This shows how the valves of the engine of Fig. 4 can be automatically operated from the shaft.)

by the operator every time the piston reaches one end of its path, the steam will turn the shaft, *S*, continually.

The operation of the valves, V_1 and V_2 , of Figs. 3 and 4 can be made automatic by the suggested arrangement of Fig. 5 where a small crank *C*, on the shaft is employed to shift the valves. Although this arrangement could be made to provide regular operation, the valves and their operating mechanism would soon show a wearing down at the rubbing surfaces which might cause leakage past the valves and noisy operation. To provide against these troubles, a simpler mechanism (Figs. 1 and 6) has been devised wherein but one valve is used and adjustment for wear (as will be explained) is automatic.

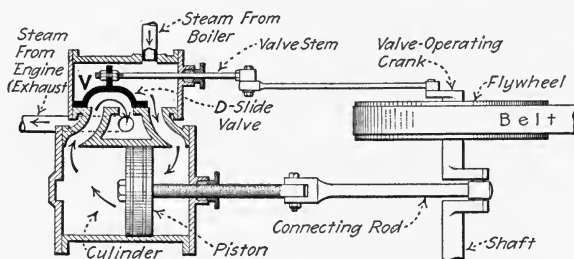

FIG. 6.—Section through cylinder of an engine which has a slide valve.

5. Heat Is Energy (as explained in the author's PRACTICAL HEAT). Although about seven existing forms of energy are known but two of these, mechanical and electrical, are directly useful for power purposes. Now, except for a small quantity of mechanical energy, known as water power, nearly all of our useful energy is derived from chemical energy existent in fuels. By combustion, the chemical energy of the fuels can be converted into heat energy. The heat energy is then (Sec. 1) available for conversion into mechanical energy.

NOTE.—THE HEAT UNIT HAS EXACT EQUIVALENTS OF MECHANICAL AND ELECTRICAL ENERGY. Experiments have proved that, when heat energy is converted into any other form of energy or when any form of energy is converted into heat, an exact and definite relationship always exists. Thus, 1 B.t.u. (British thermal unit) = 778 ft. lb. = $\frac{1}{2545}$ h.p. hr. = 0.000393 h.p. hr. = $\frac{1}{3415}$ kw. hr. = 0.000293 kw. hr.

6. No Heat Engine Can Convert Into Work All Of The Heat Which It Receives. The heat energy which the *working substance* (usually steam) contains is converted into work by virtue of the expansion of the working substance. Now, all

of the heat would be converted into work only after the substance had expanded to such a volume that its temperature would have been lowered to the absolute zero. Furthermore, since absolute zero is a temperature which will probably never be attained, and surely not in any practical machine, it follows that no substance can give up all of its heat. Therefore, if used in a heat engine, the substance cannot convert into work all of the heat which it contains. In practice, the heat which remains in the working substance, after the substance has reached the limit of its expansion, is allowed to remain in the substance—that is, no effort is made to convert this remaining heat energy into work. It is, therefore, heat energy which is rejected (*R*, Fig. 8), or not abstracted by the engine. Thus the energy in a steam engine's exhaust represents *rejected heat*.

7. The Ratio Of The "Heat Abstracted" By An Engine To The "Heat Which It Receives" May Be Called Its "Theoretical Efficiency." The theoretical efficiency of any heat engine is fixed by the specific processes whereby the working substance does work in the cylinder of that engine. This theoretical efficiency cannot be exceeded—except, sometimes, by employing different processes. The theoretical efficiency may be expressed by the formula:

$$(1) \quad \textit{Theoretical efficiency} = \frac{\textit{Heat abstracted}}{\textit{Heat received}} \quad (\textit{decimal})$$

EXAMPLE.—A heat engine receives 100,000 B.t.u. per hour from a source of heat. It rejects 75,000 B.t.u. per hour. What is its theoretical efficiency? **SOLUTION.**—By For. (1): *Theoretical efficiency* = *Heat abstracted* / *Heat received* = (*Heat received* - *Heat rejected*) / *Heat received* = (100,000 - 75,000) ÷ 100,000 = 0.25 or 25 per cent.

8. The Most Perfect Steam Engine that could be constructed (Fig. 7) would have to fulfill the following conditions: (1) *The piston and cylinders to be of a non-heat-conducting material.* (2) *Steam to be admitted at a constant pressure while the piston travels outward from the cylinder-end; the admission to stop at such instant that,* (3) *The steam within the cylinder would just expand—adiabatically—to the pressure at which it is to be exhausted.* (4) *The steam to be exhausted from the*

cylinder as the piston travels toward the cylinder-end; the exhaust to cease at such an instant that, (5) The steam remaining within the cylinder would be compressed—adiabatically—so as to just fill the clearance space at exactly the pressure of the steam which is about to be admitted, as in condition (2). Conditions (2) to (5) above, describe the cycle or processes which, when performed with a non-heat-conducting cylinder and piston, would give the highest theoretical efficiency possible for any steam engine working between certain pressure limits. All steam-engine efficiencies are, therefore, referred to the efficiency of this engine as the ideal (Div. 10). The processes (cycle) employed by such an ideal engine are called the *ideal Rankine cycle*.

9. Any Steam Engine Does Its Work By Virtue Of Energy Which It Abstracts From The Steam; see A, Fig. 8.

That this is true is shown by every steam-engine test. It was shown in Sec. 1 for the engine illustrated in the frontispiece, that the steam was cooled in passing through the engine from 364 deg. fahr. to 130 deg. fahr. Furthermore, a test would have shown that the quality of the steam was also decreased in passing through the engine. The loss in heat, which the steam undergoes due to the lowering of its temperature and the decreasing of its quality, represents heat abstracted from the steam. As will be explained, all or part of this heat loss may have been the result of the conversion of heat energy into mechanical energy (or work).

EXAMPLE.—If, in the plant illustrated in the frontispiece, the quality of the steam entering the engine is 99 per cent. and that of the leaving (exhaust) steam is 80 per cent., how much heat energy is abstracted from each pound of steam that the engine uses? SOLUTION.—From

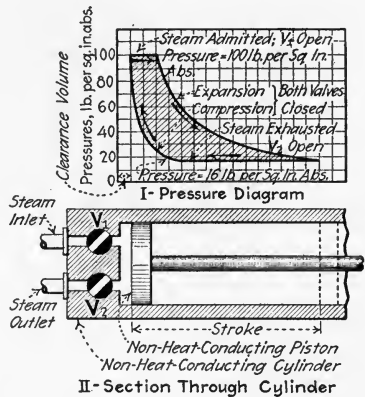

FIG. 7.—An ideal steam engine. (This engine operates upon the ideal Rankine cycle and has, therefore, the greatest theoretical efficiency that any engine can attain when working between the pressures shown.)

steam tables and charts, the total heat of 1 lb. of steam at 364 deg. fahr. and of 99 per cent. quality is 1186 *B.t.u.* Likewise, the total heat of 1 lb. of steam at 130 deg. fahr. and of 80 per cent. quality is 913 *B.t.u.* Therefore, for this engine the *heat abstracted* = 1186 - 913 = 273 *B.t.u. per pound.*

10. The Ratio Of The Work Done By The Steam To The Heat Abstracted From The Steam depends on how much heat is wasted (*L*, Fig. 8) within the engine cylinder. If an engine could be constructed with non-heat-conducting cylinder and piston it would be possible to convert into work all of the heat which is abstracted from the steam. But, since no non-heat-conducting material has ever been discovered, much less a heat non-conductor which could be used for cylinder and piston construction, the steam within an engine cylinder will always lose heat (waste it) through the walls and the piston. This heat which is lost from the steam within the cylinder is called a *thermal loss.*

11. The "Total Work Done By The Steam" Constitutes Useful Work And Mechanical Losses; *U* and *M*₁, Fig. 8. The work done by the steam can be computed (Sec. 17) from the pressures which it exerts upon the piston and the distance it causes the piston to move. As will be shown in Div. 3, this work can be measured. If, now, all of the engine's moving parts were frictionless, all of the work done by the steam would then be available for transmission, as mechanical energy, to some other machine. But, since friction cannot be entirely eliminated in any engine mechanism (Div. 16), it follows that a portion of the work done by the steam will be used up or lost within the engine itself in overcoming the friction of its own parts. This portion of the work constitutes a loss and may be termed the *mechanical loss*—or losses. Evidently, only that energy which remains after the friction is overcome can be utilized as mechanical energy. It follows, therefore, that:

(2) *Work done by steam* = *Mechanical losses* + *Useful energy.*

12. There Is A Heat Balance For Every Steam Engine; see Fig. 8. The meaning of this is that the total energy leav-

ing the engine in various forms is equal to the total heat energy which the engine receives. The various ways in which energy leaves a steam engine have been discussed in preceding sections and may be summarized as follows and as shown in Fig. 8: Of the heat, H , which an engine receives only a small part, A , is *abstracted* whereas the greater part, R , is *rejected* (Sec. 6). The rejected heat is not useful for work but may be utilized for building-heating or other industrial services. The heat, A , which the engine abstracts may be divided into: (1) *That, T , which is converted into work.* (2) *That, L , which constitutes thermal losses.* The heat, T , may again be separated into: (1) *Useful work, U .* (2) *Mechanical losses, M ,* Sec. 11.

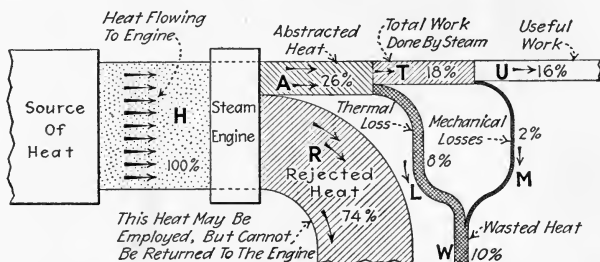

FIG. 8.—An elementary heat balance for a typical high-grade steam engine.

NOTE.—AN EFFICIENT STEAM ENGINE is one in which the ratio of useful work to heat received is large. An *efficient power plant* is one in which such use is made of the rejected heat, R (Fig. 8) that the portion thereof which is wasted is a minimum.

EXAMPLE.—For the engine, the heat balance of which is shown in Fig. 8, H represents all (100 per cent.) of the heat added to the water in the boiler to convert the water into steam. Upon receiving the steam, the engine abstracts 26 per cent. of this heat and rejects the remaining 74 per cent. Within the cylinder, 8 per cent. of the original 100 are lost thermally, L , while 18 per cent. is converted into work, T . Of this 18 per cent., 2 per cent. is lost in overcoming mechanical friction and the remaining 16 per cent. of the original 100 appears as useful work. That is, for this engine, as explained in Sec. 7, the *theoretical efficiency* = *heat abstracted* / *heat received* = $26 \div 100 = 0.26 = 26$ per cent.

13. How Steam Does Work By Direct Pressure may be understood by a study of Fig. 9 (see also the author's PRACTICAL HEAT). If, with the piston in the position illustrated, valve V_1 is opened, steam will be admitted into the space to

the left of the piston. It will exert against every square inch of the piston's face a pressure equal to that at which the steam is generated in the boiler. This pressure will exert a force tending to push the piston to the right. At the same time, however, the air acting on the right-hand face of the piston is exerting against every square inch thereof a pressure equal to that of the atmosphere. It is evident that if the boiler-pressure exceeds the atmospheric pressure, there will be an unbalanced force on the piston

tending to move it to the right. If this force is capable of moving the piston, work will be done upon the piston.

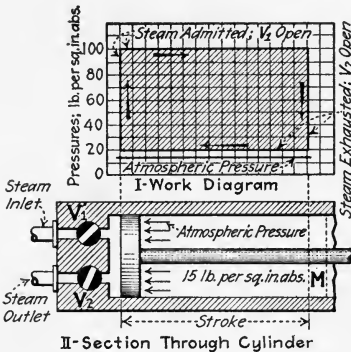

FIG. 9.—Work diagram for an engine which takes steam for a full stroke.

EXAMPLE.—If the boiler pressure (Fig. 9) is 100 lb. per sq. in. abs. and the atmospheric pressure is 15 lb. per sq. in. abs., and if the piston's area is 100 sq. in., the total force which acts on the left face of the piston will be 100 sq. in. × 100 lb. per sq. in. = 10,000 lb. Likewise, the force acting on the piston's right face will be 100 sq. in. × 15

lb. per sq. in. = 1,500 lb. The net or unbalanced force will be 10,000 – 1,500 = 8,500 lb. If, now, this force is able to move the piston, the work done for each foot that the piston is moved will be 1 ft. × 8,500 lb. = 8,500 ft. lb. If the stroke (distance moved by the piston) is 2 ft., then the work done per stroke will be 8,500 × 2 = 17,000 ft. lb.

NOTE.—THE "NET PRESSURE" ON THE PISTON, at any instant, is the difference between the pressures on its two sides. The work done during a stroke is equal to the product of the average net pressure, the piston's area and the length of the stroke. In the above example the net pressure is 100 – 15 = 85 lb. per sq. in.

14. Work Must Sometimes Be Done Upon The Steam In Expelling It From The Cylinder.—If, in Fig. 9, after the piston reaches the position, *M*, shown by dotted lines, *V*₁ is closed and *V*₂ is opened, the pressure at the left of the piston will be reduced as the steam escapes through *V*₂ until the pressure in the cylinder is equal to that within the vessel into which the steam exhausts. This pressure is called the *back pressure*. The value of this back pressure may vary from 1 or 2 lb. per

sq. in. abs. (when a condenser is used, Div. 9) to 35 lb. per sq. in. abs. or more. Whenever the back pressure is in excess of atmospheric pressure (in a single-acting engine as shown in Fig. 9,) the net pressure on the piston will act opposite to the direction in which the piston must be moved to exhaust the steam from the cylinder. Under such circumstances this net pressure must be overcome by using some external means for exhausting the steam. The external force then does work upon the steam in overcoming the net pressure. As in the preceding section, the work done is equal to the net pressure times the piston area times the distance moved or stroke.

EXAMPLE.—If, in Fig. 9, the back pressure on the engine is 20 lb. per sq. in. abs, what work must be done upon the steam to exhaust it and what is the net work done by the steam per double-stroke? SOLUTION.—The work done on the steam during each exhaust stroke is $(20 - 15) \times 100 \times 2 = 1,000$ ft. lb. Since, by the example of Sec. 13, the work done during the admission stroke is 17,000 ft. lb., the net work for the two strokes is $17,000 - 1,000 = 16,000$ ft. lb.

NOTE.—THE “EFFECTIVE PRESSURE” ON AN ENGINE PISTON, for any of its positions, is the difference between the two net pressures which act upon it when it is travelling in opposite directions through that position. Thus, for the engine of Fig. 9, the effective pressure for any position is $85 - 5 = 80$ lb. per sq. in. The net work of the steam upon the piston could have been found by multiplying together the piston area, stroke, and effective pressure. Thus: *net work* = $100 \times 2 \times 80 = 16,000$ ft. lb.

NOTE.—THE “WORKING STROKE” OR “POWER STROKE” of any heat engine is understood to mean the movement of the piston from one end of its travel to the other while one charge of the working substance urges the piston onward. Thus, in the engine of Fig. 9, the movement of the piston toward the right constitutes a working stroke. The return of the piston to the left is termed its *return stroke*. A working stroke together with a return stroke constitutes a *double stroke*. In formulas in this book, $N_s =$ number of working strokes per minute.

NOTE.—SINGLE AND DOUBLE-ACTING ENGINES are those in which working strokes are performed as the piston moves respectively in one or both directions. The engine of Fig. 9, since steam is admitted only on one side of its piston, is a single-acting engine. Steam engines are usually constructed so as to admit steam to both sides of the piston (Fig. 3); they are then double-acting since working strokes are then performed as the piston moves in either direction. From these definitions it follows that in double-acting steam engines each stroke is a working stroke, whereas in single-acting steam engines only alternate strokes are working strokes.

15. How Steam Does Work By Expansion may be understood by reference to Fig. 10. The same engine as illustrated in Fig. 9 is now shown taking steam for only one-half stroke. The line AB represents the pressure during the first half-stroke while V_1 is open. When V_1 is closed (B), the net pressure of the steam is still 85 lb. per sq. in. Further movement of the piston to the right, however, will cause the pressure within the cylinder to decrease. Thus, as the piston completes its stroke, the pressure will drop as indicated by the curve

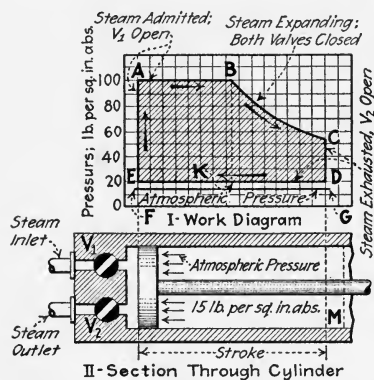

FIG. 10.—Work diagram for an engine which takes steam for only part stroke. (This engine is taking steam for only one-half stroke.)

BC . The net pressure on the piston likewise decreases. Thus, at the end of the stroke, the net pressure is as represented by GC . The back pressure is represented by EF or by GD . Just as the net pressure varies from B to C , so does the effective pressure now vary for different positions from B to C . Effective pressures are now represented by the vertical distances from ED to ABC . Also, the *net work* is represented by the shaded area $ABCDE$. The net work is computed by multiplying together the piston area, stroke, and *average* or *mean effective pressure*. Methods of finding the mean effective pressure are given in Div. 3.

EXAMPLE.—For the engine of Fig. 10, the mean effective pressure is 68 lb. per sq. in. Therefore, the *net work* = $100 \times 2 \times 68 = 13,600$ ft. lb. Of this, $100 \times 1 \times 80 = 8,000$ ft. lb. were done along AB and $13,600 - 8,000 = 5,600$ ft. lb. were done along BC .

16. The Economy Of Using Steam Expansively is illustrated by the example of the preceding section. It should be noted that, in Fig. 10, since steam was admitted to the cylinder for only one-half stroke, the weight of steam admitted was little more than one-half that admitted to the engine of Fig. 9. As used in Fig. 9, the weight of steam admitted in Fig. 10 would

do only about 8,000 ft. lb. of work. But in Fig. 10 it was found to do 13,600 ft. lb. Now, the difference of 5,600 ft. lb. was done at the expense of no greater quantity of steam and, therefore, of heat. The saving effected by the expansive use may be expressed as $5,600 \div 8,000 = 0.70$ or 70 per cent. Note, however, that although the Fig. 10 arrangement works the more economically than does that of Fig. 9, it does less total work—13,600 ft. lb. as against 16,000 ft. lb. It follows that the Fig. 10 cylinder, to do the same amount of work as in Fig. 9, would have to be increased in size in the ratio of 16,000 to 13,600. Or, it would have to be about 18 per cent. larger. The conclusions to be drawn from the above are:

- (1) *That expansion increases the ratio of work done to heat used.*
- (2) *That expansion necessitates a larger cylinder for a given work output.*

Further considerations which attend expansive use of steam are given in Div. 10.

NOTE.—THE EXPANSIVE USE OF STEAM IS NOT DESIRABLE IN ENGINES OF CERTAIN CLASSES, such as hoisting engines, steam pumps, and steam hammers. An engine which uses steam expansively, if stopped in a position where the admission valve is closed, cannot be started without moving the engine mechanism, by some outside means, until the valve opens. This, of course, is undesirable in engines which must be frequently stopped, as must those listed above. These engines, therefore, are not usually so made as to use steam expansively.

17. To Compute The Work Done Per Double-Stroke By Any Steam Engine, use the following formula, which is simply the mathematical expression of the rules of Sec. 14:

$$(3) \quad W = A_{ip}L_{js}P_m \quad (\text{ft. lb. per double stroke})$$

Wherein: W = work done in one end of a cylinder per double stroke (Sec. 14), in foot pounds. A_{ip} = area of piston, exclusive of any rod, see note below, which passes through the cylinder end, in square inches. L_{js} = length of stroke, in feet. P_m = mean effective pressure (Sec. 15), in pounds per square inch.

NOTE.—THE EFFECT OF ROD AREA, since the rod area subtracts from the total area upon which the steam can act, is cared for by subtracting the area of the rod from the total cross-sectional area of the cylinder whenever a rod extends through the cylinder end or *head*. Single-acting engines (Sec. 14) seldom have a rod extending through the cylinder head.

Double-acting engines may have a rod extending through one cylinder head or they may have rods extending through both heads. Since the area of the piston rod seldom exceeds from $\frac{3}{4}$ to $1\frac{1}{2}$ per cent. of the cylinder area, it may well be neglected in practical problems and in approximations. In exact determinations, however, it must be considered.

EXAMPLE.—A single-acting engine, which takes steam at only one end and has no rod passing through the head, has a piston 10 in. in diameter and a stroke of 30 in. If the mean effective pressure is 66 lb. per sq. in., what work is done per double-stroke? SOLUTION.—Substituting in For. (3): $W = A_{ip}L_{fs}P_m = (10 \times 10 \times 0.785) \times (30 \div 12) \times 66 = 12,925.5$ ft. lb. per double-stroke.

18. To Compute The Power Developed In Any Steam Engine, the elements of time must be introduced into the work equation of Sec. 17. Since power is the rate of doing work (see the author's PRACTICAL HEAT) it may be expressed in foot pounds per second or in foot pounds per minute or in B. t. u. per hour and so on. In this book, power will usually be measured in horse power. The *horse power* is equivalent to 550 ft. lb. per sec. or 33,000 ft. lb. per min. The following formulas, which follow from the preceding, give the power which is developed in only one end of the cylinder. For a double-acting engine compute for each end separately, allowing for the piston-rod area if necessary. Then add the two results.

$$(4) \quad P = P_m L_{fs} A_{ip} N_s \quad (\text{ft. lb. per min.})$$

$$(5) \quad P_{ihp} = \frac{P_m L_{fs} A_{ip} N_s}{33,000} \quad (\text{horse power})$$

Wherein: P = power developed *in one end of the cylinder*, in foot pounds per minute. P_{ihp} = power developed in one end of the cylinder (indicated power), in horse power. P_m = mean effective pressure, in pounds per square inch. L_{fs} = length of stroke, in feet. A_{ip} = area of piston, exclusive of the area of any rod which passes through the cylinder end, which is under consideration, in square inches. N_s = number of double strokes per minute, see note under Sec. 14; for steam engines with rotative crank shafts: $N_s = N$ = the angular speed of the crank shaft, in revolutions per minute. (Only engines with rotative crank shafts will be considered in this book.)

EXAMPLE.—If the engine of the example of Sec. 17 has a crank shaft which makes 100 r.p.m., what is its indicated power in foot pounds per minute and in horse power? SOLUTION.—By For. (4): $P = P_m L_{fs} A_{ip} N_s = WN_s = 12,925.5 \times 100 = 1,292,550 \text{ ft. lb. per min.}$ By For. (5): $P_{ihp} = P_m L_{fs} A_{ip} N_s / 33,000 = P / 33,000 = 1,292,550 \div 33,000 = 39.2 \text{ h.p.}$ See also the example under Table 20.

19. To Compute The Approximate Mean Effective Pressure of a simple steam engine (Sec. 33) when an indicator diagram (Sec. 78) cannot be obtained, the following formula may be useful. Since engines with throttling governors (Sec. 215) do not take steam at boiler pressure except under very heavy load, the formula can only be used for such engines when it is known that the governor valve is wide open.

(6) $P_m = 0.9[K(P_g + 14.7) - P_a]$ (pounds per square inch
Wherein: P_m = the approximate mean effective pressure, in pounds per square inch. K = a constant, as found from Table 20, depending on the apparent cut-off. P_g = the pressure of the steam in the engine's supply pipe, or the boiler pressure, in pounds per square inch gage. P_a = the back pressure on the engine, in pounds per square inch absolute; for non-condensing engines P_a may be taken at 17 lb. per sq. in. abs.; for condensing engines, P_a is found from the condenser vacuum gage and barometer readings.

20. Table Of Constants For Use In Calculating Approximate Mean Effective Pressure.—The values of K tabulated below are those to be used in For. (6) of the preceding section.

Cut-off		K	Cut-off		K	Cut-off		K
Frac-tion	Per cent.		Frac-tion	Per cent.		Frac-tion	Per cent.	
$\frac{1}{6}$	17	0.545	$\frac{3}{8}$	37	0.773	$\frac{2}{3}$	67	0.943
$\frac{1}{5}$	20	0.590	$\frac{2}{5}$	40	0.794	$\frac{7}{10}$	70	0.954
$\frac{1}{4}$	25	0.650	$\frac{1}{2}$	50	0.864	$\frac{3}{4}$	75	0.970
$\frac{3}{10}$	30	0.705	$\frac{3}{5}$	60	0.916	$\frac{4}{5}$	80	0.981
$\frac{1}{3}$	33	0.737	$\frac{5}{8}$	63	0.927	$\frac{7}{8}$	88	0.993

NOTE.—In this table the fraction or percentage cut-off is obtained by dividing the distance that the piston has travelled from the beginning of its stroke when the steam is cut-off, by the whole length of stroke; that is, it is the *apparent cut-off*, Sec. 135.

EXAMPLE.—Find the mean effective pressure of a non-condensing engine, which cut-offs at one-half stroke, if the boiler pressure is 80 lb. per sq. in. gage. If the engine is double-acting, runs at 320 r.p.m., has a piston 7 in. in diameter, and has a 10-in. stroke, what is its horse power? SOLUTION.—By Table 20, $K = 0.864$ for $\frac{1}{2}$ stroke. Substituting in For. (6): $P_m = 0.9 [K(P_g + 14.7) - P_a] = 0.9 \times [0.864(80 + 14.7) - 17] = 58.3$ lb. per sq. in. Then, by For. (5): $P_{ihp} = P_m L_{fs} A_{ip} N_s / 33,000 = [58.3 \times (10 \div 12) \times (7 \times 7 \times 0.785) \times 320] \div 33,000 = 18.1$ h.p., for one end. Now, since the engine is double-acting, the total horse power will (disregarding piston-rod area) be twice that of one end or: *total horse power* = $2 \times 18.1 = 36.2$ h.p.

21. The Form Of The Expansion Line For Steam, as it expands within the engine cylinder, is different for different

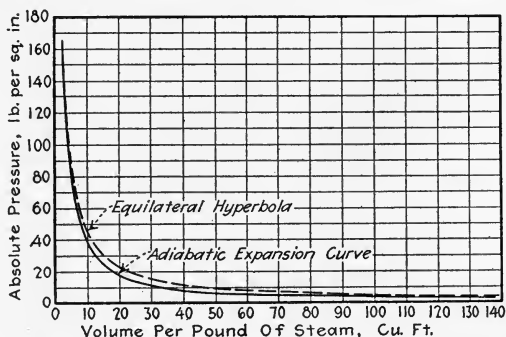

FIG. 11.—Graphs comparing adiabatic expansion curve and equilateral hyperbola for steam expanding from 165 lb. per sq. in. abs. to 2 lb. per sq. in. abs.

engines. As assumed in the Rankine cycle (Sec. 8), if the cylinder and piston were of non-heat-conducting material the expansion would be *adiabatic*. That is, the steam would suffer no gain or loss of heat by heat transfer. During expansion the heat content of the steam would decrease at the same rate as that at which the steam does work upon the piston. The exact form of the expansion curve would depend somewhat upon the initial and final steam pressures. Since, however, no cylinder or piston is non-heat-conducting, the form of the actual expansion line will differ from the adiabatic curve. Experiments show that the expansion generally

follows very nearly an equilateral hyperbola. The construction of the equilateral hyperbola is given in Sec. 108.

EXAMPLE.—The adiabatic expansion curve for steam expanding from 165 lb. per sq. in. to 2 lb. per sq. in. is plotted in Fig. 11. An equilateral hyperbola is also plotted alongside it (dashed).

QUESTIONS ON DIVISION 1

1. What is the primary function of the steam engine?
2. How is heat energy derived?
3. How is mechanical energy transmitted? How heat energy?
4. Draw a sketch of a steam engine and enumerate the principal parts.
5. Explain the term *clearance*. Define *displacement volume*. How is clearance usually expressed? What is *piston clearance*? How is it measured?
6. Explain, with a sketch, the operation of an elementary steam engine with hand-operated valves. How can the valves be made to operate automatically? Show with a sketch.
7. Show, by a sketch, the form of a single valve which controls the steam flow to both ends of a cylinder.
8. In what forms is energy available for man's use? In what forms is it most frequently employed? How is energy transformed to the useful forms?
9. State the mechanical and electrical-energy equivalents of the British thermal unit.
10. Why cannot an engine convert into work all of the heat which it receives? What becomes of that which is not abstracted?
11. Define *theoretical efficiency*. Upon what does the theoretical efficiency of an engine depend? Give the formula for theoretical efficiency.
12. Explain the construction and operation of the theoretically most perfect steam engine. Why is it not practical? What is its cycle called?
13. Whence does a steam engine derive its ability to do work?
14. Into what two classes does the heat which an engine abstracts from the steam first divide? Which of these constitutes a direct loss? The abstracted heat which does not constitute a direct loss is how used?
15. Draw a heat balance diagram to show the disposition of all of the heat which an engine receives.
16. Explain what distinguishes an efficient steam engine. An efficient power plant. Can an efficient power plant be made up of inefficient steam engines? Why?
17. Explain how steam does work by direct pressure. Define *net pressure*.
18. Explain how work is sometimes required to drive exhaust steam from an engine cylinder. Define *effective pressure*. Define *a working stroke*.
19. Explain how steam does work by expansion. Define *mean effective pressure*. Explain, with a diagram, the economy of using steam expansively. What classes of engines do not use steam expansively? Why?
20. Give the formula for finding the net work done per double-stroke by the steam upon the piston. Explain its derivation.
21. Define *power*. What are its units? State the horse power formula for engines.
22. Give the formula for finding the approximate mean effective pressure of a steam engine. To what classes of engines may it be applied? Upon what three variables does the mean effective pressure depend?
23. What form does the expansion line take for steam which expands in an actual engine cylinder? What form has it in the Rankine cycle?

PROBLEMS ON DIVISION 1

1. A 10-in. by 12-in. engine has a clearance volume of 185 cu. in. at the head end and 180 cu. in. at the crank end. If the piston rod is 1.5 in. in diameter, what are the clearances in per cent. of the displacement volumes?

2. A steam engine is supplied with dry saturated steam at a pressure of 160 lb. per sq. in. abs. and exhausts steam of 89 per cent. quality at 17 lb. per sq. in. abs. What is its theoretical efficiency?

3. A double-acting hoisting engine with a 9-in. -diameter piston and 12-in. stroke takes steam (for full stroke, Sec. 13) at 125 lb. per sq. in. gage and exhausts at 4 lb. per sq. in. gage. How much work does the steam do per working stroke? If the engine is running at 200 r.p.m., what is its horsepower? Neglect piston-rod area.

4. If the engine of Prob. 3 were arranged to cut off at $\frac{1}{5}$ stroke what would be its horse power?

DIVISION 2

STEAM-ENGINE MECHANISMS AND NOMENCLATURE

22. The Classification Of Steam-Engine Types which follows is rearranged from an outline in STEAM POWER by Hirshfeld and Ulbricht. As there is an overlapping of the various types, it would be impractical to discuss engines according to this table. Hence no effort will be made to do so. Definitions of the various terms employed in this table are given in following sections. These are then followed by brief descriptions of some other frequently used steam-engine terms, and of the types of governors.

23. Table of Classifications of Steam-Engine Types.

Basis of classification	Primary subdivision	Secondary subdivision
(1) Cylinder arrangement	(A) Single cylinder (B) Tandem (C) Cross (D) Duplex (E) Opposed (F) Angle	
(2) Longitudinal axis	(A) Vertical (B) Inclined (C) Horizontal	
(3) Rotative speed	(A) High speed (B) Medium speed (C) Low speed	
(4) Ratio of stroke to diameter	(A) Short stroke (B) Long stroke	
(5) Valve gear	(A) Slide valve	(a) D-slide valve (b) Balanced valve (c) Multiported valve (d) Gridiron valve (e) Piston valve
	(B) Corliss valve	(a) Detaching (b) Positively-operated
	(C) Poppet valve	(a) Detaching (b) Positively-operated

Basis of classification	Primary subdivision	Secondary subdivision
(6) Engine mechanism	(A) Standard (B) Back-acting (C) Trunk-piston (D) Oscillating-cylinder	
(7) Steam expansion	(A) Single expansion	
	(B) Multi-expansion	(a) Compound (b) Triple (c) Quadruple
(8) Steam flow	(A) Counter flow (B) Uniflow	
(9) Steam conditions	(A) Initial pressure	(a) High pressure (b) Medium pressure (c) Low pressure
	(B) Initial temperature	(a) High superheat (b) Low, or no superheat
	(C) Back pressure	(a) Condensing (b) Non-condensing

24. A Vertical Steam Engine (Fig. 12) is one which has the center line of its cylinder, *M*, in a vertical position.

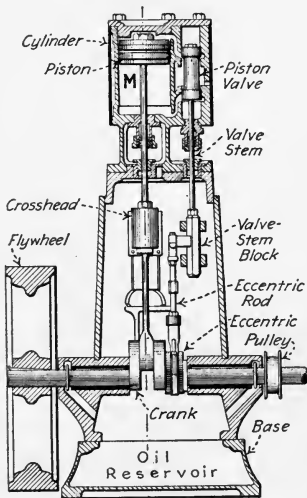

FIG. 12.—A vertical steam engine.

25. A Horizontal Steam Engine (Fig. 13) is one which has the center line, *CL*, of its cylinder in a horizontal position.

26. An Inclined Steam Engine (Fig. 14) is one which has the center lines, *CL*, of its cylinders inclined from the horizontal or vertical position.

27. A Side-Crank Engine (Figs. 17 to 21) is one which has its crank attached at the end of the shaft overhanging the main bearing. In engines of this type the crank, *C* (Fig. 15), is generally forged as a separate part and fastened securely to the shaft, *S*.

28. A Center-Crank Engine (Fig. 12) is one which has its crank located between the crank-

shaft bearings. In this type of engine, the crank, *C* (Fig. 16), is generally forged as part of the shaft, *S*.

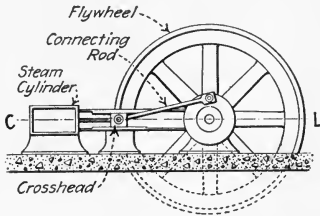

FIG. 13.—A horizontal steam engine.

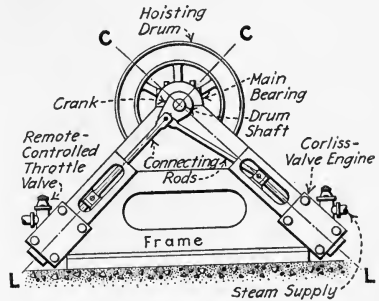

FIG. 14.—An inclined Corliss engine as used for large-capacity mine hoists.

29. A Right-Hand Engine (Fig. 17) is a side-crank engine the flywheel of which is mounted on the right side of the

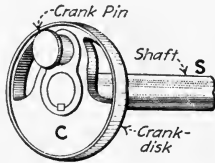

FIG. 15.—Forged crank for a side-crank engine.

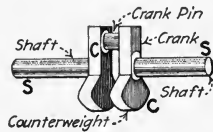

FIG. 16.—Solid forged crank and shaft for a center-crank engine.

cylinder axis, *CL*, as viewed from the head end of the cylinder, *O*.

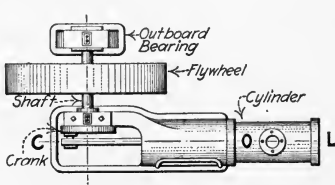

FIG. 17.—A right-hand engine.

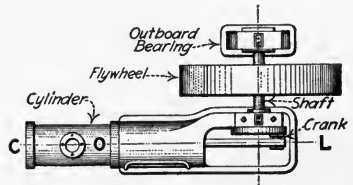

FIG. 18.—A left-hand engine.

30. A Left-Hand Engine (Fig. 18) is a side-crank engine the flywheel of which is mounted on the left side of the cylinder axis, *CL*, as viewed from the head end of the cylinder, *O*.

31. An Engine Is Said To "Run Over" (Fig. 19) when the top of the flywheel, *T*, is turning away from the cylinder, *C*. This term is applied only to horizontal and inclined engines.

NOTE.—THE DIRECTION OF ROTATION OF A VERTICAL ENGINE IS ORDINARILY SPECIFIED AS CLOCKWISE OR COUNTER-CLOCKWISE as viewed from the valve side of the engine. *Clockwise* (sometimes called *right-hand*) rotation is in the direction of motion of the hands of a clock. *Counter-clockwise* (*left-hand*) rotation is in the reverse direction of clockwise rotation. Thus, in Fig. 19, the flywheel is turning clockwise. In Fig. 20, the flywheel is turning counter-clockwise.

NOTE.—STATIONARY ENGINES USUALLY ARE DESIGNED TO "RUN OVER," so the pressure between the crosshead and the crosshead guide,

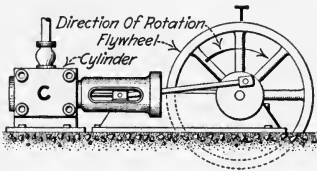

FIG. 19.—Engine "running over."

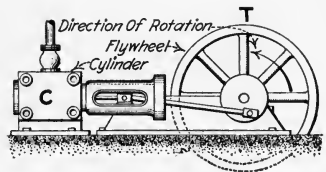

FIG. 20.—Engine "running under."

due to the angularity of the connecting-rod, comes on the lower side of the crosshead only, and also so the belt, which usually leads away from the engine, will have the driving pull on the lower side. Hence the direction for running over is sometimes referred to as "*running forward*." Sometimes the term "*running clockwise*" is intended to mean "*running over*," or forward, and in the same direction as the hands of a clock to an observer viewing an engine with the shaft to his right hand and the cylinder to his left. It follows that the terms *clockwise* and *counter-clockwise* applied to an engine are often confusing, as the direction will appear to be clockwise to a person standing on one side and counter-clockwise to one standing on the other side. Therefore it is best to confine the designations of directions of rotation to the terms "*running over*" and "*running under*."

32. An Engine Is Said To "Run Under" (Fig. 20) when the top of the flywheel, *T*, is turning toward the cylinder, *C*. This term is applied only to horizontal and inclined engines.

33. A Simple Engine (Figs. 12 and 21) is one in which the conversion of the heat energy of the steam into mechanical

work occurs in one stage or step only. This conversion is brought about in one cylinder, *C* (Fig. 21), only and by using but one piston, *P*.

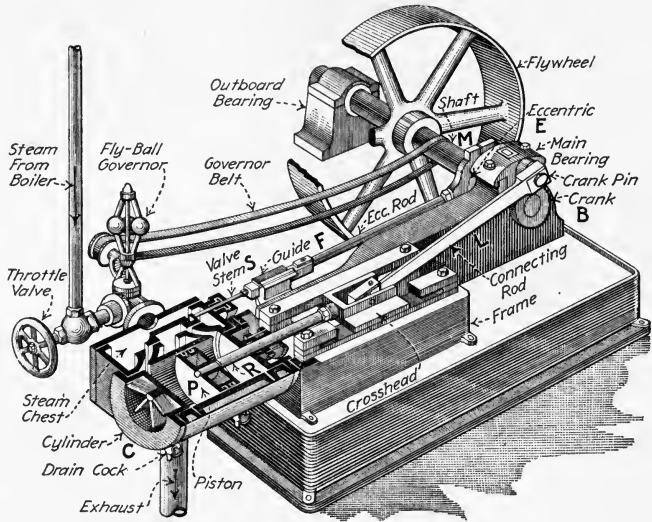

FIG. 21.—Simple D-slide valve engine with fly-ball governor.

NOTE.—A TWIN-CYLINDER ENGINE, SOMETIMES CALLED A DOUBLE ENGINE, (Fig. 22) is one which consists of two simple-engine cylinders which are placed side by side and parallel, and whose pistons are connected by separate connecting rods to the same crank shaft. Twin cylinder engines are widely used for hoisting and for driving heavy machinery.

34. A Compound Engine (Fig. 23) is one in which the conversion of the heat energy of the steam takes place in two stages or steps. Steam enters the high-pressure cylinder, *H*, where it undergoes the *first stage of its expansion*. The steam is then exhausted into the receiver. From the receiver it passes into the low-pressure cylinder, *L*, where the *second-stage expansion* occurs.

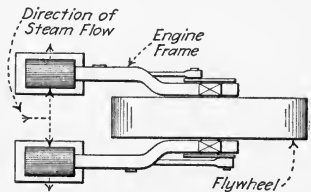

FIG. 22.—Plan view of a twin-cylinder engine.

35. A Tandem-Compound Engine (Fig. 23) is a compound engine with its two cylinders, *H* and *L*, along a common axis,

or "in line." A tandem-compound engine has only one crosshead and one connecting rod and has both of its pistons on a common piston rod, *R*.

36. A Cross-Compound Engine (Fig. 24) is a compound engine which has two parallel cylinders, *H* and *L*, on the

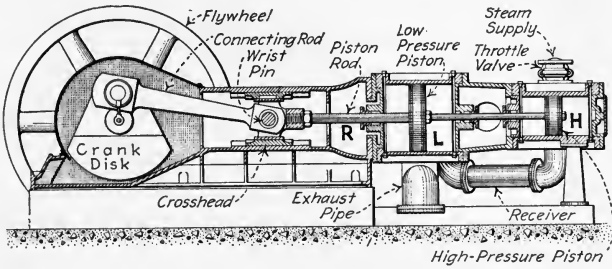

FIG. 23.—A tandem-compound engine (Ball Engine Company).

same side of the crank shaft, each piston being connected by a separate connecting rod to the one crank shaft.

37. A Duplex-Compound Engine (Fig. 25) is a compound engine, the cylinders of which are parallel and adjacent to each other as shown. *H* is the high-pressure cylinder con-

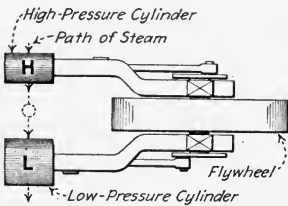

FIG. 24.—Diagrammatic plan view of a cross-compound engine.

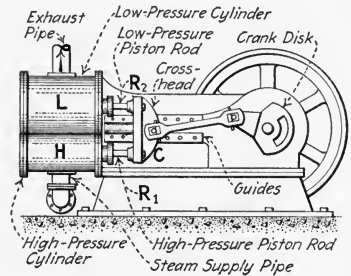

FIG. 25.—A duplex-compound engine.

nected to, *L*, the low-pressure cylinder. The piston rods, *R*₁ and *R*₂, are connected to the same crosshead, *C*. This type of engine occupies the same floor space as does a simple engine, but has the advantages of a compound engine with respect to economy of steam consumption (Div. 8).

38. An Angle-Compound Engine (Fig. 26) is a compound engine which has its two cylinders, *A* and *B*, placed at right angles to each other. The connecting rods are connected to the same crank shaft and usually to the same crank pin.

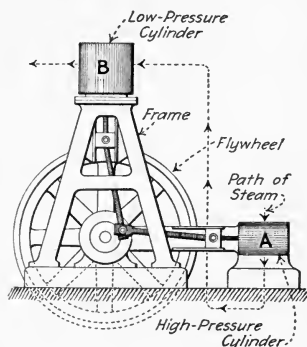

FIG. 26.—Elevation of an angle-compound engine.

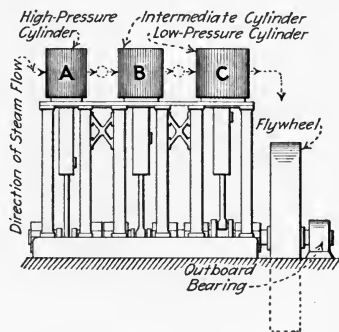

FIG. 27.—Elevation of a triple-expansion engine.

39. A Triple-Expansion Engine, Sometimes Called A Triple-Compound Engine (Figs. 27 and 28) is one in which the heat energy of the steam is converted into work in three successive stages and in at least three separate cylinders, as

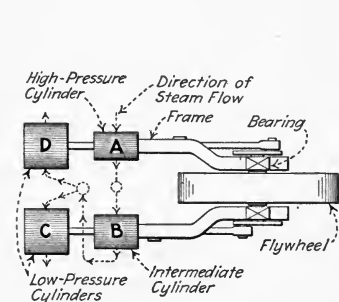

FIG. 28.—A plan view of a triple-expansion engine with two low-pressure cylinders.

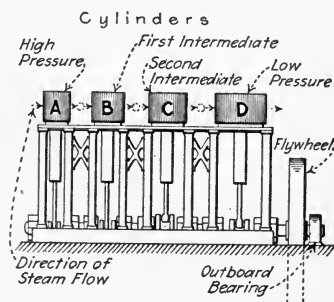

FIG. 29.—Elevation of a quadruple-expansion vertical engine.

A, *B*, and *C*, Fig. 27. A triple-expansion engine with four cylinders is shown in Fig. 28 in which *A* is the *high-pressure*, *B* is the *intermediate*, and *C* and *D* are the *low-pressure cylinders*.

40. A Quadruple-Expansion Engine, Sometimes Called A Quadruple-Compound Engine (Fig. 29) is one in which the heat energy of the steam is converted into work in four successive stages, and usually in four separate cylinders, *A*, *B*, *C*, and *D*. *A* is the *high-pressure cylinder*, *B* the *first intermediate cylinder*, *C* is the *second intermediate cylinder*, and *D* the *low-pressure cylinder*.

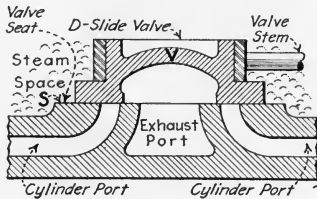

FIG. 30.—Cross-section of a D-slide valve and its seat.

is a positively operated valve which has a reciprocating motion and which slides upon a face, *S*, called its *seat*. As the valve slides back and forth on its seat, it uncovers *ports* (holes in the seat leading to either end of the cylinder) placing these ports into communication with either the supply or exhaust pipe. There are two principal types of slide valves:—(1) *Flat type*, Figs. 21 and 30. (2) *Piston type*, Figs. 12 and 33.

NOTE.—STEAM-ENGINE VALVES ARE DISCUSSED IN DETAIL IN DIVISIONS 4 and 5. The illustrations and definitions following are merely to acquaint the reader with the several valve-types in their more simple forms.

42. A D-Slide Valve (Figs. 21 and 30) is a flat valve, *V* Fig. 30, having a cross-sectional form similar to the letter “D.” The pressure of the steam in the steam chest forces the valve against its seat, *S*, preventing leakage of the steam between *V* and *S*. In cases where the D-valve is very large, the force due to the steam pressure on the valve is apt to be very great and cause excessive friction at the rubbing surfaces. To prevent excessive resistance due to this friction, balanced valves are used.

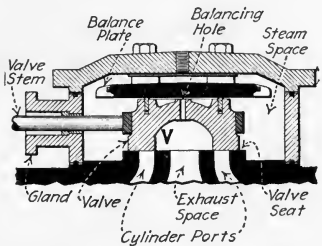

FIG. 31.—Balanced, flat, D-slide valve.

43. A Balanced Slide Valve (Fig. 31) is one in which the bearing pressure of the valve, *V*, upon its seat due to the

pressure of the steam is minimized by some special design, which usually permits the same steam pressure to act on both sides of the valve; for explanation see Sec. 139. The piston valve, Fig. 12, is also a balanced slide valve.

44. A Multiported Valve (Fig. 32) is one in which there are two or more passages through which steam can flow into or out of the cylinder ports. Multiported valves permit shorter valve travel and quicker opening and closing of the ports than is possible with common (*single-ported*) slide valves. In Fig. 32, the ports, *H*, are the *cylinder ports*; and the port, *L*, is the *exhaust-steam port*. Multiported slide valves are also frequently made in the "balanced" form (see Div. 4).

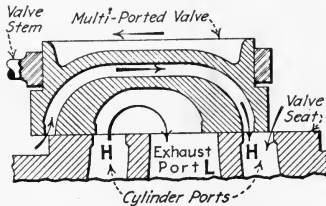

FIG. 32.—Multiported slide valve.

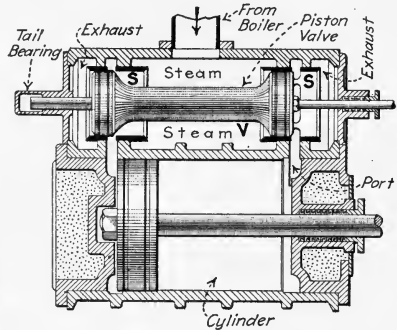

FIG. 33.—Section of cylinder with a piston valve. (Chandler and Taylor Company.)

45. A Piston Slide Valve (Fig. 33) is a cylindrical-shaped valve, *V*, which is given reciprocating motion in a cylindrical seat, *S*. Its action is very similar to that of the simple *D*-valve. There are these differences, however: (1) *The piston valve is "balanced."* (2) *The piston valve usually is of the "center admission" construction, whereas D-valves usually are of the "center exhaust" construction.;* see Sec. 136.

NOTE.—PISTON SLIDE VALVES ARE PARTICULARLY DESIRABLE IN VERTICAL ENGINES, since, by making the upper portion of the valve of greater diameter than the lower portion, it is thereby possible to balance the weight of the valve and its valve rod and thus minimize the wear on the eccentric.

46. A Riding-Cut-off Valve (Fig. 34) is one having at least two moving parts, each controlled by a separate eccentric

(see Div. 4). In Fig. 34, *M* is the *main valve* controlling the points of admission, compression, and release; and *R* is the *cut-off valve* riding upon the main valve, and controlling only the point of cut-off (Sec. 135).

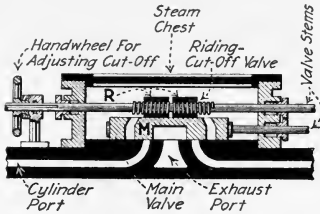

FIG. 34.—Section of a Meyer riding-cut-off valve.

NOTE.—THE POINT IN THE STROKE AT WHICH THE CUT-OFF VALVE CUTS OFF may be: (1) Fixed, in which case the cut-off valve is neither hand adjustable nor governor-operated. (2) Variable, in which case the cut-off valve may be either hand-adjustable or governor-operated. With a hand-adjustable cut-off valve, the point of cut-off may be adjusted to any required point, while the engine is running; thereby the speed of the engine can

be changed for a given load or for a changed load the point of cut-off may be altered to that which is most economical or which will give the desired speed. With a governor-operated cut-off, the advance-angle of an eccentric associated with the flywheel governor changes automatically the cut-off to maintain the engine speed constant with varying load.

47. A Gridiron Valve (Fig. 35) is a reciprocating valve which has the form of a gridiron or grating. In Fig. 35, the riding-cut-off valve and the main valve, *M*, are both of the gridiron type. The valve seat, *S*, has long rectangular openings between the little bars just as have the valves themselves.

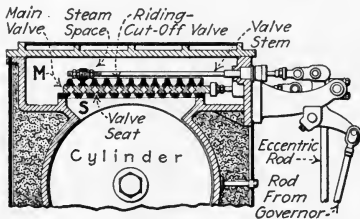

FIG. 35.—Section of a cylinder with a gridiron valve (McIntosh and Seymour valve).

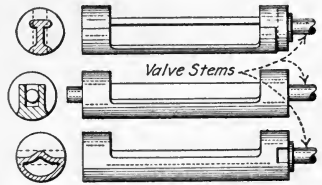

FIG. 36.—Single-ported Corliss valves.

Evidently, then, *gridiron valves* are multiported valves with a large number of ports.

48. A Corliss Valve (Figs. 36 and 37) is a valve the ends of which are cylindrical and which oscillates about its axis in a cylindrical cavity or seat at right angles to the engine

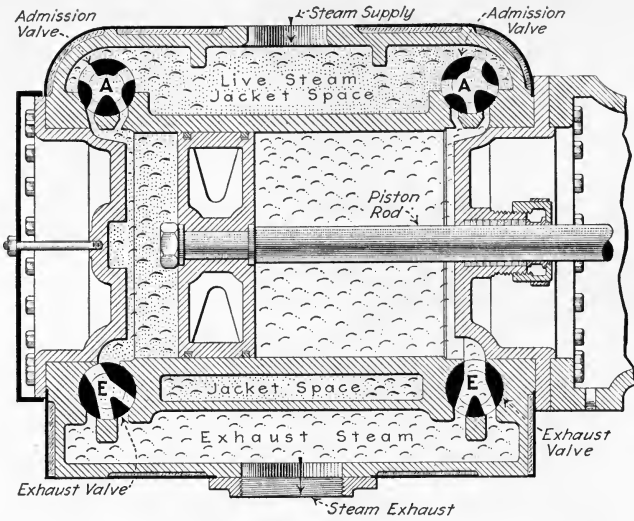

FIG. 37.—Section of cylinder with double-ported Corliss valves.

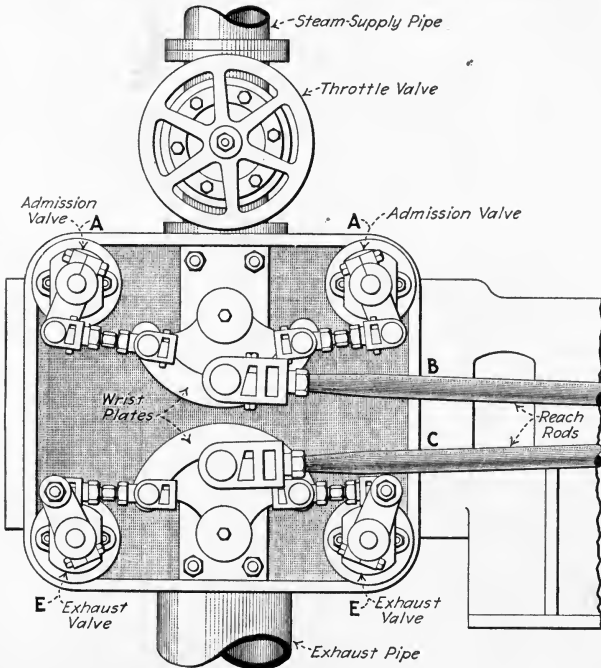

FIG. 38.—Chuse positively-operated Corliss-valve mechanism

cylinder axis. The cylinder ports are opened or closed by this oscillatory motion. Corliss valves are employed two to a cylinder end—one for admitting steam to the cylinder, the other for exhausting the spent steam from the cylinder. An engine with Corliss valves is therefore a *four-valve engine*. Corliss valves may be either single-ported (Fig. 36) or, as more commonly constructed, multiported (Fig. 37).

49. A Positively-Operated, Or Non-Releasing, Corliss-Valve Mechanism (Fig. 38) is one in which the admission

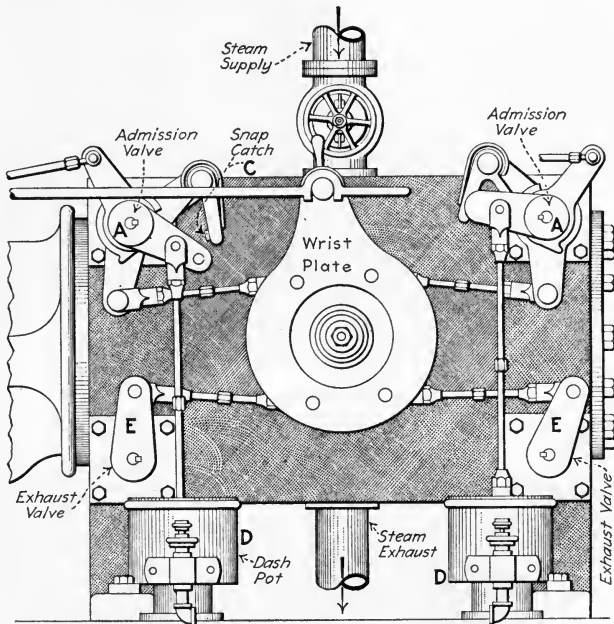

FIG. 39.—Detaching Corliss-valve mechanism.

valves, *A*, and the exhaust valves, *E*, are at all times positively connected to, and under the influence of, the valve-operating (eccentric) mechanism to which they are linked by the reach rods *B* and *C*.

50. A Detaching, Or Releasing, Corliss-Valve Mechanism (Fig. 39) is one in which the admission valves, *A*, are not positively connected to, nor under the influence of, the eccentric mechanism except when these valves are open. A dash-

pot mechanism, *D*, provides a suction for quickly closing the steam valves as soon as they are detached from the eccentric mechanism. Detachment is effected by releasing a snap-catch, *C*, which is controlled by the governor. The exhaust valves, *E*, are positively connected to the eccentric mechanism at all times.

51. A Poppet Valve (Figs. 40, 41, and 42) is a circular valve, *V*, Fig. 40, having an opening and closing movement perpendicular to its seat, *S*, and which allows steam to flow under or through it. This type of valve effects a large port-opening with a small valve-lift and is free of the friction occurring with valves which slide upon their seats. Poppet valves, on account of their symmetrical construction and small size, are well adapted for use with high-temperature superheated steam.

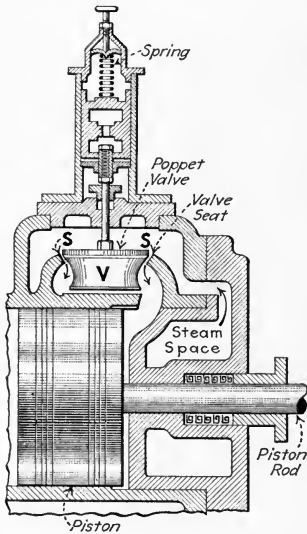

FIG. 40.—Section of cylinder with single-seated poppet admission valve.

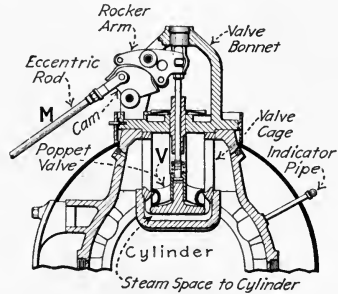

FIG. 41.—Half-section of end of Nordberg-engine cylinder showing positively-operated poppet admission valve.

52. A Positively-Operated Poppet Valve (Fig. 41) is one that is positively opened and closed by, and at all times under the influence of, the valve-operating (eccentric) mechanism. In Fig. 41, *V* is the poppet valve and *M* the eccentric rod from an eccentric on a lay-shaft which is located on the side of the engine and parallel to the cylinder axis.

53. A Detaching, Or Releasing, Poppet Valve (Fig. 42) is one that is opened by the eccentric mechanism, but is closed by a spring, dash-pot, or other mechanism; the valve is, there-

fore, under the direct influence of the eccentric mechanism only during the opening period. In Fig. 42, *V* is the poppet valve, *S* the valve-closing spring, and *M* the eccentric rod from a lay-shaft eccentric.

54. A Single-Valve Engine (Figs. 12 and 21) is one in which one valve controls both steam admission and exhaust for both ends of the cylinder. Thus, engines with D-slide valves, whether single or multiported, balanced or unbalanced, and engines with simple piston valves are all single-valve engines.

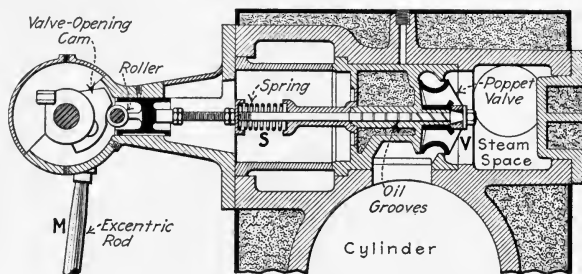

FIG. 42.—Half-section of a Hamilton-engine cylinder with detaching-poppet admission valve.

55. A Multi-Valve Engine (Fig. 37) is one in which more than one valve is employed for admitting and exhausting steam at the two ends of the cylinder. Thus, all Corliss, poppet, and gridiron-valve engines are of this type.

56. A Short-Stroke Engine is one the stroke of which is less than the diameter of its cylinder. For example, an engine which has a cylinder 12 in. in diameter and a 10-in. stroke is a short-stroke engine.

57. A Long-Stroke Engine is one the stroke of which is greater than the diameter of its cylinder. Thus an engine which has a cylinder 7 in. in diameter and a 10-in. stroke is a long-stroke engine.

58. A Counterflow, Or Double-Flow, Engine (Figs. 43 and 44) is one in which the direction of steam flow in its cylinder on the exhaust stroke is opposite to the direction of steam flow during the admission stroke. Thus in Fig. 43, steam is shown entering the cylinder and flowing toward the

right. In Fig. 44, the steam is being exhausted and, as is seen, must flow in the opposite direction or toward the left.

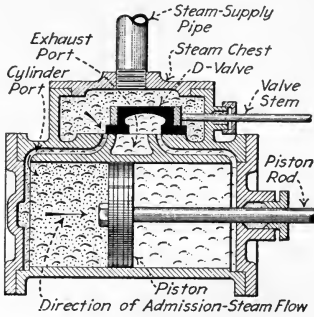

FIG. 43.—Showing direction of steam flow into an engine cylinder employing the counterflow principle.

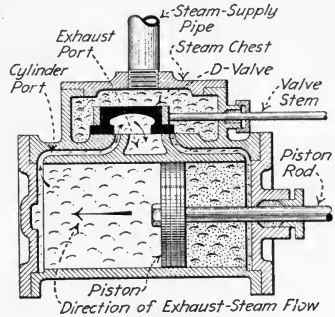

FIG. 44.—Showing direction of steam flow during exhaust from a cylinder employing the counterflow principle.

NOTE.—CERTAIN ENGINES WITH SEPARATE ADMISSION AND EXHAUST VALVES ARE ALSO COUNTERFLOW ENGINES, if the exhaust valves take the steam out of the cylinder at its end. Thus, the Corliss engine (Fig. 37) is a counterflow engine.

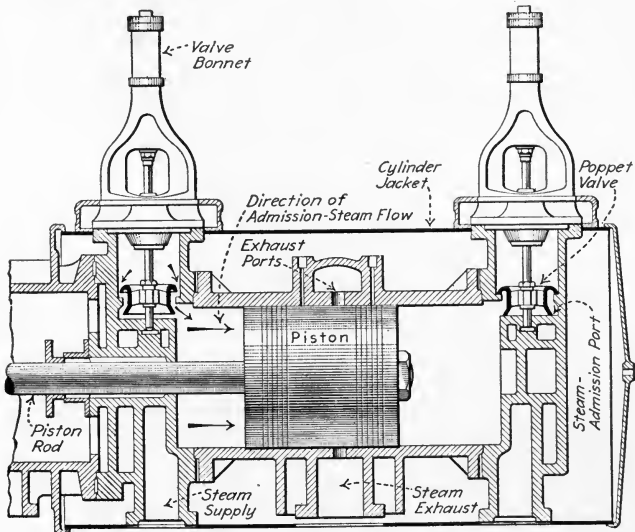

FIG. 45.—Showing direction of steam flow into a uniflow-engine cylinder.

59. A Uniflow Engine (Figs. 45 and 46) is one in which the steam flows in only one general direction in the cylinder.

The direction of steam flow during the exhaust period is the same as during the admission period. Fig. 45 shows steam

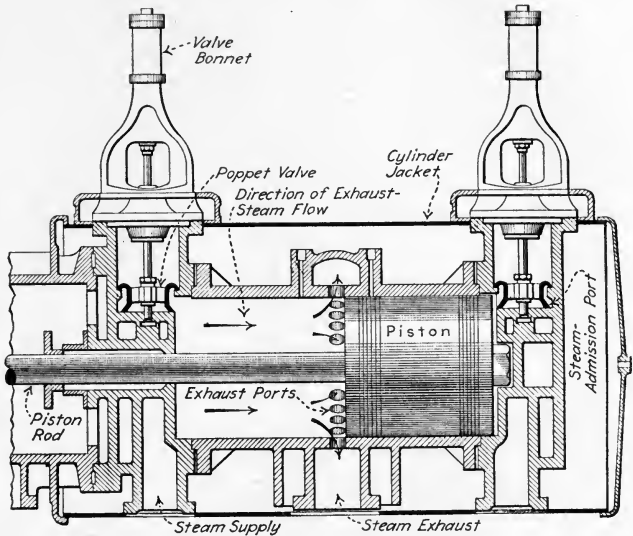

FIG. 46.—Showing direction of steam flow during exhaust from a uniflow-engine cylinder.

being admitted into a uniflow engine cylinder and flowing toward the right. Fig. 46 shows the same steam being exhausted from the cylinder and also flowing toward the right.

60. A Standard Crank-Mechanism (Fig. 21) is one consisting of a cylinder, *C*, a piston, *P*, a piston rod, *R*, a crosshead, a connecting rod, *L*, a crank, *B*, and a crank shaft, *M*—and in which the crosshead is located between the cylinder and the crank and crank shaft.

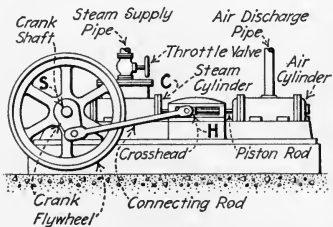

FIG. 47.—A double-connecting-rod, back-acting crank-mechanism as applied to air compressors.

61. A Back-Acting Crank-Mechanism (Fig. 47) consists of the same principal parts as the standard crank-mechanism; in the back-acting crank-mechanism, however, both the crank shaft, *S*, and the cylinder, *C*, are always on the same side of the crosshead, *H*. This

mechanism, will usually necessitate either two piston rods or two connecting rods, or a combination of two piston rods and two connecting rods.

62. A Trunk-Piston Mechanism (Fig. 48) is one employing an unusually long, or trunk piston, *P*, in which one end of the connecting rod is pivoted on a pin, thus rendering unnecessary the cross-head used in other types of steam-engine mechanisms. Engines with trunk pistons are single-acting. That is, the steam for them is admitted to, and does work on, only one side of the piston. Internal combustion (automobile, etc.) engines are usually of the trunk-piston type.

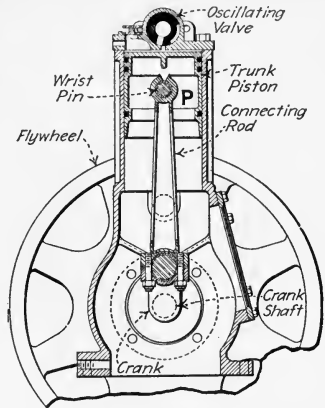

FIG. 48.—Trunk-piston mechanism of the Model Aeme engine. (Automatic Furnace Co., Dayton, O.)

63. An Oscillating-Cylinder Engine (Fig. 49) is one, the mechanism of which consists of a cylinder, *C*, pivoted in

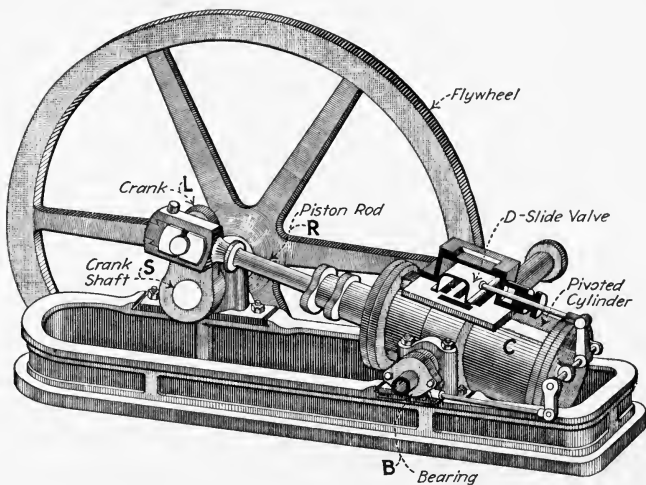

FIG. 49.—An old engine of the oscillating-cylinder type.

bearings, *B*; a piston and piston rod, *R*; a crank, *L*; and a crank shaft, *S*. In this type of engine, the oscillating cylinder

takes the place of the connecting rod and crosshead employed in the standard crank-mechanism.

64. A Condensing Engine is one which normally operates on an absolute back (exhaust) pressure which is less than that of the atmosphere. The back pressure is reduced by condensing the exhaust steam by the use of some condensing device (Div. 9).

65. A Non-Condensing Engine is one which operates on a back (exhaust) pressure equal to, or greater than, atmospheric pressure.

66. A High-Speed Engine is one which operates at a speed of about 200 r.p.m. or more.

67. A Medium-Speed Engine is one which operates at some speed between about 110 and 200 r.p.m.

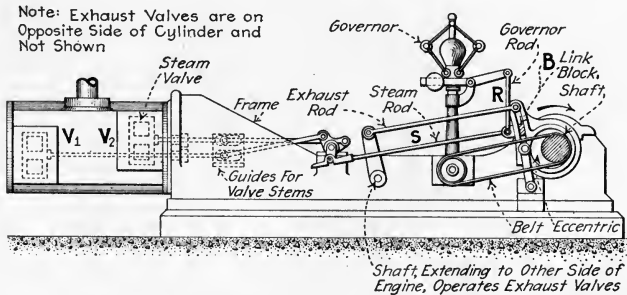

FIG. 50.—An engine equipped with a variable-cut-off valve-mechanism. (Porter-Allen engine.)

68. A Low-Speed (Or Slow-Speed) Engine is one which operates at a speed of 100 r.p.m. or less.

69. A High-Pressure Engine is one which takes steam at its throttle at a pressure greater than 225 lb. per sq. in. gage.

70. A Medium-Pressure Engine is one which takes steam at its throttle at some pressure between 80 lb. and 225 lb. per sq. in. gage.

71. A Low-Pressure Engine is one which takes steam at the throttle at a pressure less than 80 lb. per sq. in. gage.

72. A Fixed-Cut-Off Engine (Fig. 21) is one in which the point of cut-off remains constant throughout all ranges of load and speed. The eccentric, *E*, is fixed to the shaft, *M*. Therefore, the eccentric rod, *F*, valve stem, *S*, and valve

always have the same motion relative to the engine cylinder and valve seat. That is—their relative motion is independent of the engine load or speed.

73. A Variable-Cut-Off Engine (Fig. 50) is one in which the point of cut-off varies with each change of load or speed. In Fig. 50, as the engine speed increases, the governor rod, *R*, lowers the link block, *B*, thus diminishing the travel of the steam rod, *S*, and the steam valves, *V*₁ and *V*₂. By means of this mechanism the point of cut-off varies with different speeds and hence with different loads; see following sections on governors.

74. A Steam-Engine Governor (Figs. 51 and 52) is a device which changes the steam input to an engine to meet

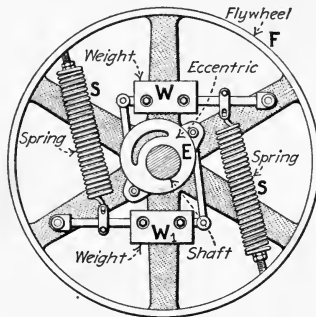

FIG. 51.—Typical shaft governor.

the varying demands of different engine loads, and at the same time maintains the engine speed as nearly constant as possible. (See Divisions 6 and 7.) Steam-engine governors are of two general types—(1) Shaft type, Fig. 51. (2) Fly-ball type, Fig. 52.

75. A Shaft Governor (Fig. 51; see also Div. 7) is one which rotates with the flywheel in a plane perpendicular to the crank-shaft axis. In this type of mechanism, weights, *W* and *W*₁, are rotated with the flywheel, *F*. Rotation of these weights introduces centrifugal or inertia forces which act against the pull of springs, *S*, attached to *F*. The position of the weights depends upon these forces which are proportional to the engine speed. The position on the shaft of the eccentric, *E*, is varied by the movement of the weights which fly outward

as the flywheel speed increases. Since the relative position of the eccentric on the shaft controls the valve action, a governor of this type will perform the necessary functions as given in the preceding section. See Div. 7 for further discussion of shaft governors.

76. A Fly-Ball Governor (Figs. 50 and 52; see also Div. 6) is one in which two or more "fly-balls" rotate, usually in a horizontal plane. Rotation introduces centrifugal forces which hold the balls away from the axis of rotation. Suitable

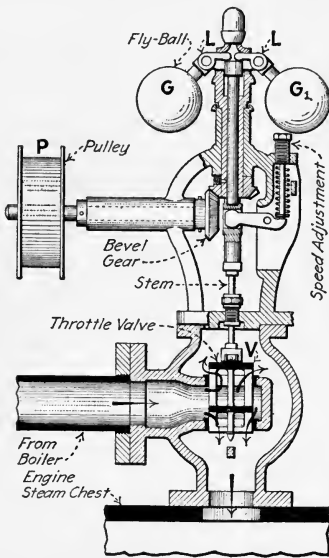

FIG. 52.—Section of a typical fly-ball throttling governor.

mechanism affords a relation between the position of the balls and the amount of steam fed to the engine. In Fig. 52, the position of the fly-balls, G and G_1 , fixes the amount of opening of the throttle valve, V , thus regulating the steam supply to the engine. Since the governor pulley, P , is belted to the engine shaft (see Fig. 21), the fly-ball positions depend upon the engine speed. As the load increases, the engine speed begins to decrease. The governor opens the throttle valve and thereby again increases the engine speed. Likewise when the load decreases, the engine speed increases and the governor closes

the throttle valve thereby maintaining the speed practically constant.

QUESTIONS ON DIVISION 2

1. How are engines classified as to:
 - (a) Cylinder arrangement?
 - (b) Longitudinal axis?
 - (c) Rotative speed?
 - (d) Ratio of stroke to diameter?
 - (e) Valve gear?
 - (f) Engine mechanism?
 - (g) Steam expansion?
 - (h) Steam flow?
 - (i) Steam conditions?

2. What is a vertical engine? A horizontal engine? An inclined engine?
3. Explain the chief difference between a side-crank and a center-crank engine.
4. What is a right-hand engine? A left-hand engine?
5. When is an engine said to run "over"? To run "under"?
6. Explain fully the meaning of the following terms:
 - (a) A simple engine.
 - (b) A compound engine.
 - (c) A tandem-compound engine.
 - (d) A cross-compound engine.
 - (e) A duplex-compound engine.
 - (f) An angle-compound engine.
 - (g) A triple-expansion engine.
 - (h) A quadruple-expansion engine.
7. What is a slide valve?
8. What is a D-slide valve?
9. Describe and give the features of a balanced slide valve.
10. What is a multiported valve?
11. Describe the piston slide valve.
12. Describe the riding-cut-off valve.
13. What is a gridiron valve?
14. Describe fully the features of the Corliss valve.
15. What is the chief difference between a positively-operated and a detaching Corliss-valve mechanism?
16. Describe the principle of operation of a poppet valve.
17. Explain the difference between a positively-operated and a detaching poppet valve.
18. What is a single-valve engine?
19. What is a multi-valve engine?
20. When is an engine said to have a "short stroke"? A "long stroke"?
21. What is the difference in principle between a counterflow engine and a uniflow engine?
22. Describe the following engine mechanisms:
 - (a) Standard crank-mechanism.
 - (b) Back-acting crank-mechanism.
 - (c) Trunk-piston mechanism.
 - (d) Oscillating-cylinder mechanism.
23. What is a condensing engine?
24. What is a non-condensing engine?
25. Give the speed ranges for: (a) A high-speed engine. (b) A medium-speed engine. (c) A low-speed engine.
26. Give the steam-pressure ranges for: (a) A high-pressure engine. (b) A medium-pressure engine. (c) A low-pressure engine.
27. What is a fixed-cut-off engine?
28. What is a variable-cut-off engine?
29. Explain the purposes of a steam-engine governor.
30. What is a shaft governor?
31. Describe the fly-ball governor

DIVISION 3

STEAM-ENGINE INDICATORS AND INDICATOR PRACTICE

77. The Steam-Engine Indicator (Fig. 53) is simply an instrument which records graphically on an "indicator diagram" (D, Fig. 54) the variations of pressure within an engine cylinder, as the engine piston occupies different positions

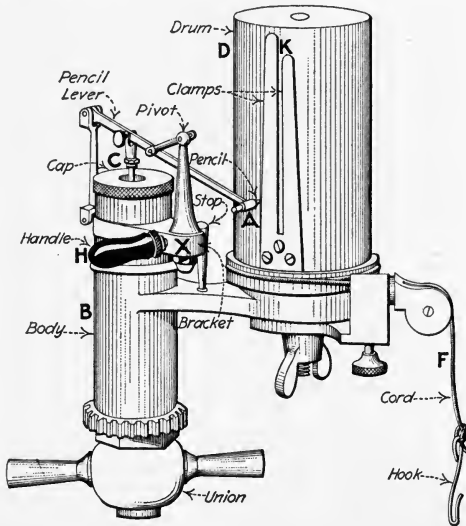

FIG. 53.—External view of a Thompson indicator without reducing motion. (American Steam Gage and Valve Co.)

throughout its stroke. It might well be called a recording pressure gage, the chart of which is moved always at a speed proportional to the speed of the piston. See the author's PRACTICAL HEAT for a discussion of the principle of the elementary indicator.

78. The Indicator Diagram Is Extremely Useful (D D, Fig. 54) because it enables one to analyze what is taking

place inside the engine cylinder while the engine is running. There are, briefly, three ultimate ends to which such analyses lead:—(1) *They reveal whether the engine steam and exhaust valves are opening and closing properly in relation to the position of the engine piston.* (2) *They enable one to calculate the power developed by the expansion of the steam within the engine cylinder.* (3) *With further calculations, they enable one to determine, approximately, the amount of steam which the engine is using.* Besides these three important functions, the indicator diagram may reveal extraordinary troubles or defects which would otherwise be difficult to allocate. These uses of the indicator diagram will be considered separately in subsequent sections.

79. Watt's Indicator Is Perhaps The Simplest Form (Figs. 54 and 55). Steam enters the indicator cylinder, *C*, from the engine cylinder, *E*. The pressure of the steam forces the piston *P*, upward, compressing the spring, *S*, and raising the pencil, *A*.

The sheet of paper, *R*, being moved at the same time by cord, *F*, which is attached to the crosshead of the engine, will have described upon it a "diagram," *DD*, which indicates, at every instant during a revolution of the engine, the pressure within the engine cylinder. At any instant, the height to which the pencil has been raised will be a measure of the pressure at that instant within the engine cylinder, whereas the horizontal distance through which the paper has been moved from either end (for example, *M*, Fig. 54) will denote the position of the piston in the engine cylinder at that instant. From this it follows that the length, *L*, of the diagram represents the length of the engine piston's stroke.

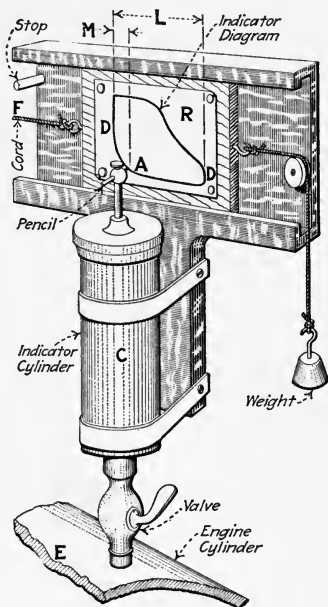

FIG. 54.—External diagrammatic view of Watt's steam-engine indicator.

NOTE.—MODERN INDICATORS (Figs. 53, 56, and 57) DIFFER FROM WATT'S TYPE only in constructional details. In a modern indicator the paper, upon which the diagram is traced, is held by clamps, *K* (Fig. 53) to a cylindrical drum, *D*, which is given a rotative motion by the cord, *F*, from the engine crosshead. Also, the pencil, *A*, in a modern indicator is made to move a distance greater than the motion of the indicator piston. This is accomplished by means of a *pencil mechanism*. Then too, some modern indicators have the spring, *S*, outside the hot cylinder (Fig. 57), better adapting them for use with superheated steam.

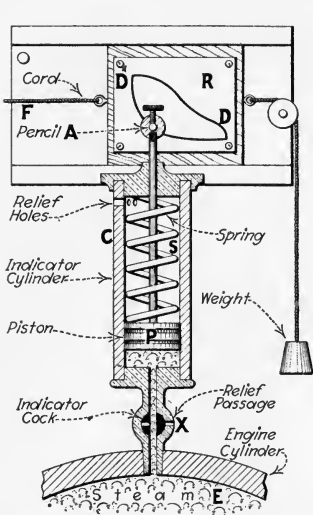

FIG. 55.—Sectional diagrammatic view of Watt's steam-engine indicator.

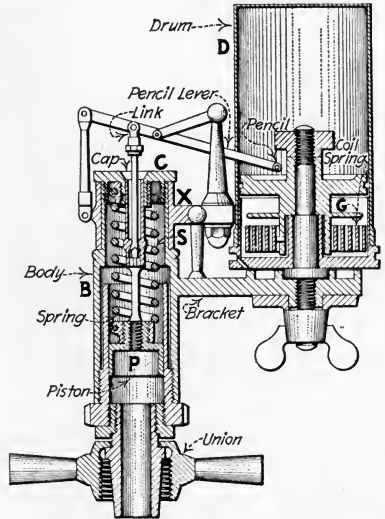

FIG. 56.—Sectional view of a Thompson indicator.

80. The Pencil Mechanism (Figs. 58 and 59) permits the use of strong indicator springs (Sec. 92) which need not be compressed (or extended) through a great distance and still affords a diagram of reasonable height. By thus minimizing the extent of motion of the heavier parts, meanwhile reducing the weight of those which have greater movement, modern indicators have been made reasonably free from inertia effects at the usual engine speeds. A good pencil mechanism will trace a straight *vertical* line upon a card held on the drum (not in motion). It will also cause the pencil to move through a distance *exactly proportional* to (usually four to five times) the movement of the indicator piston.

81. The Two Principal Types Of Pencil Mechanism Are The "Parallel-Link" And "Curved-Slot" mechanisms (Figs. 58 and 59). The parallel-link mechanism, in some makes of indicators, differs slightly in details from the arrangement of Fig. 58 (see PRACTICAL HEAT). In the curved-slot mechanism the roller on the pencil arm is kept within the slot, *S*, which is so formed that the point is given the desired vertical motion.

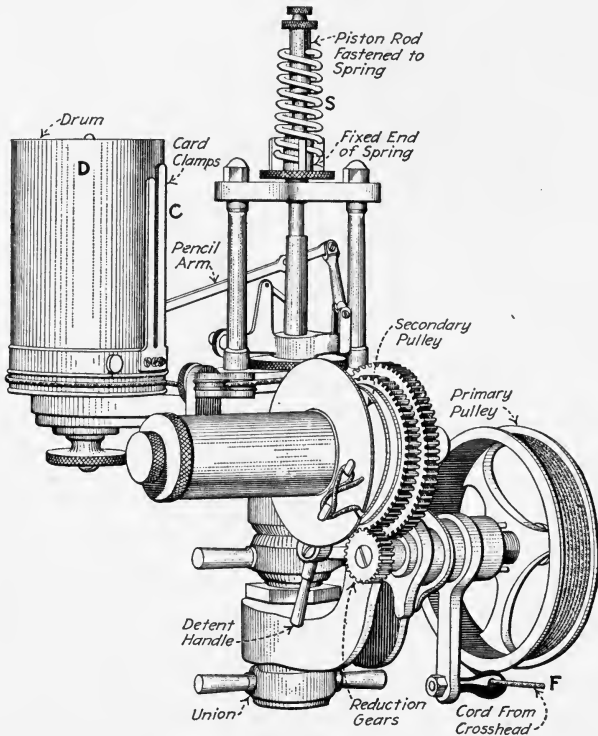

FIG. 57.—Crosby outside-spring indicator with reducing wheel attached.

82. An Indicator Reducing Mechanism Usually Called A "Reducing Motion" (Fig. 60) is necessary (whenever the stroke of the engine is greater than the longest diagram that can be drawn on the indicator drum) to insure that the full motion of the engine piston may be represented on the indicator card. As the length of diagram attainable with

most indicators is from 4 to 6 in., it is evident that nearly all engines will require reducing mechanisms of some kind.

NOTE.—Experience shows that for speeds over 300 r.p.m. the length of diagram should not exceed 3 in.;—speeds over 200— $3\frac{1}{2}$ in.;—speeds 100 to 200—4 in.; speeds under 100—optional.

83. There Are Four Principal Types of Indicator Reducing Mechanisms. These are the: (1) *Pendulum lever*, Fig. 60. (2) *Pantograph*, Fig. 62 (3) *Reducing wheel*, Fig. 66 (4) *Inclined Plane*, Fig. 69. The first three are the ones most commonly used. Any of these reducing mechanisms can be made practically perfect but, if not carefully set up, may give results which are very much in error. Each type will be discussed.

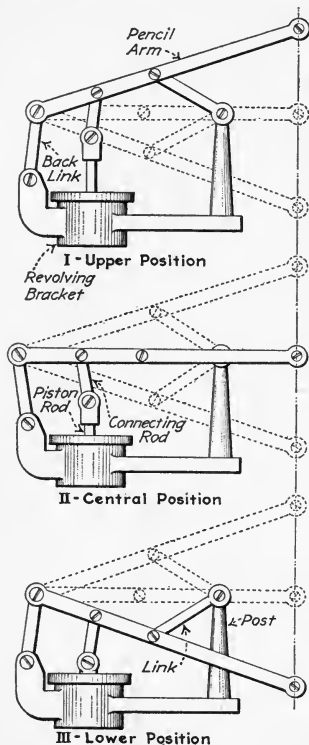

FIG. 58.—Lever pencil-mechanism for producing a straight vertical line. (This is used on Thompson indicators.)

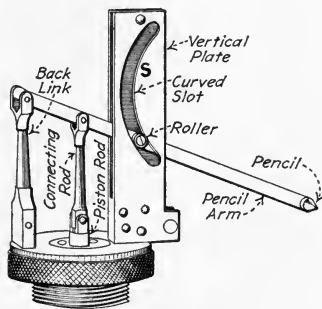

FIG. 59.—Curved-slot parallel motion of Tabor indicator.

84. The Pendulum-Lever Reducing Mechanism (Fig. 60) is very widely used and gives an accurate reduction if certain requirements are observed in its construction. The pendulum lever, *P*, should be at least as long as the engine stroke and *must*, in its mid-position, *ab* (Fig. 60), be at right angles to the direction of motion of the crosshead. The connecting link, *C*, between the pendulum lever and the crosshead should

be about half the length of the engine stroke, L . The pendulum lever and the connecting link *must* be so arranged that the point, m , where they are fastened will be the same distance above the line cd when the crosshead is at either end of its

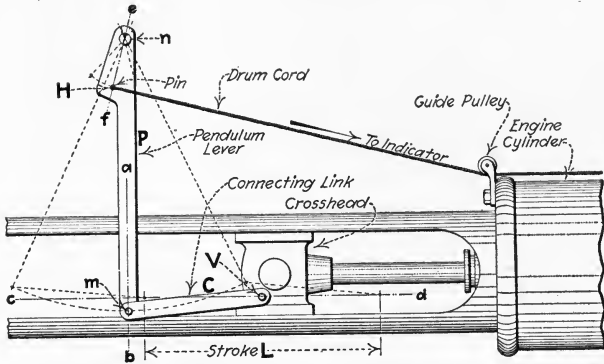

FIG. 60.—Pendulum-lever reducing motion.

travel, as it is below cd when in mid-stroke. The line cd is a line, parallel to the axis of the engine cylinder, which passes through the center V of the point of attachment of the connecting link to the crosshead. Also the drum cord must be led

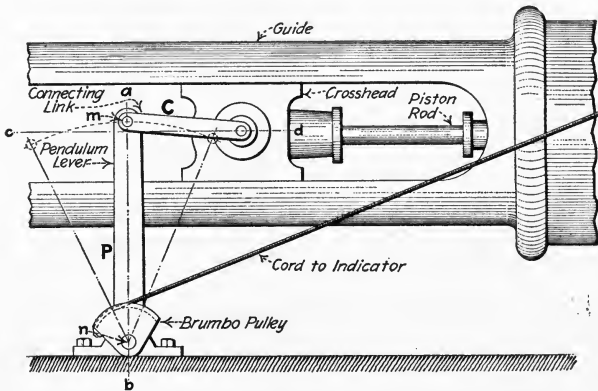

FIG. 61.—Inverted pendulum-lever with brumbo pulley.

off at an angle of 90 deg. to the mid-position, ef , of its lever arm. To do this, it is sometimes necessary to enlarge that portion of the lever as shown. Frequently, a segment of a

grooved pulley (Fig. 61) is substituted for the pin, *H*, on the pendulum lever. This segment is called a *brumbo pulley*.

NOTE.—THE PIVOT POINT, *n*, IS FREQUENTLY PLACED BELOW THE CROSSHEAD (Fig. 61) when it is inconvenient to provide a bearing for it overhead. In such cases, the entire mechanism is simply inverted and very often the bearing is fixed to the floor.

NOTE.—TO FIND THE POINT OF ATTACHMENT, *H*, (Fig. 60) or the distance, *Hn*, from the pivot point to the pin (or radius of brumbo pulley), to produce a certain length of diagram: RULE.—*Multiply the total length of the lever, mn, by the desired length of indicator diagram and divide by the stroke, L, of the engine, all in inches.*

TO FIND THE LENGTH OF DIAGRAM produced with the cord at a certain point of attachment: RULE.—*Multiply the distance from pivot, n, to point of attachment, H, by the stroke, L, and divide by the total length of the lever, mn, all in inches.*

EXAMPLE.—An engine with a 30-in. stroke is provided with a pendulum lever 35 in. long. To obtain an indicator diagram 3 in. long, how far from pivot must the pin be placed? SOLUTION.— $35 \times 3/30 = 3\frac{1}{2}$ in.

EXAMPLE.—An engine with a 24-in. stroke has a 5-ft. pendulum lever with a brumbo pulley having a radius of 10 in. How long an indicator diagram will it give? SOLUTION.— $10 \times 24/60 = 4$ in.

85. The Pantograph Is An Instrument Which May Be Used As A Reducing Mechanism (Figs. 62 and 63) because it contains two points whose motions are always parallel and proportional to each other. It may be briefly described as a number of links pivoted together so that they form two sets of parallel links. One point, *A*, (Fig. 62 or 63) is fixed stationary. Another point, *B*, is given a certain motion, while a third point, *C*, will receive a motion proportional and parallel to that of *B*. Points *A*, *B*, and *C* must originally be selected, however, on the same straight line, as shown. Figs. 64 and 65 show methods of using pantographs on engines. Note that the cord is always taken from the pantograph in a direction parallel to the axis of the cylinder.

NOTE.—THE POSITION OF POINT *C* CAN BE FOUND if the travel of *B* and the desired travel of *C* (Figs. 62 to 65) are known, by substituting in this formula,

$$(7) \text{ Distance } AC = \frac{\text{travel of } C \times \text{distance } AB}{\text{travel of } B}$$

EXAMPLE.—If Fig. 65 represents an engine whose stroke is 24 in., and an indicator diagram 4 in. long is desired, and if, in the position shown it

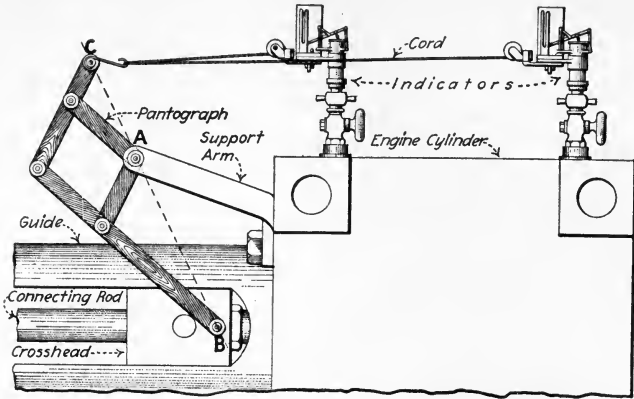

FIG. 62.—Simple pantograph for indicator-reducing purposes.

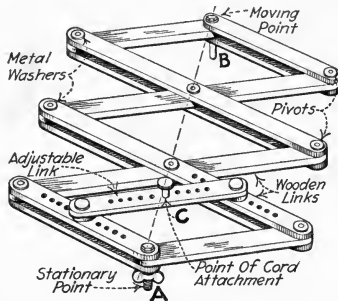

FIG. 63.—Adjustable pantograph for indicator-reducing use.

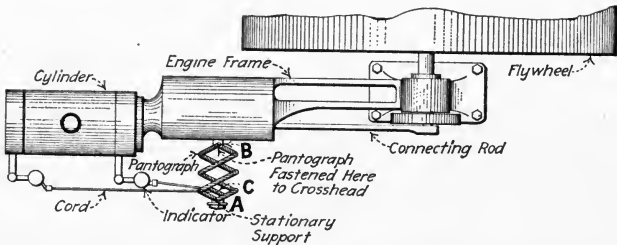

FIG. 64.—Plan view of an engine fitted with pantograph and indicators.

is 36 in. from A to B, what must be the distance AC? SOLUTION.—Distance AC = $4 \times 36/24 = 6$ in.

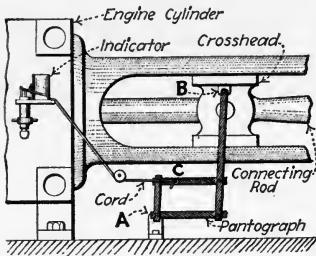

FIG. 65.—Elevation of an engine with a pantograph.

86. The Reducing Wheel, Figs. 66 and 57, is a device in which a cord is run directly from the crosshead onto a pulley which it rotates, while another cord is run from a second pulley to the indicator drum—the second pulley being either smaller or geared to a slower rotative speed than the first and driven directly from the first.

87. Features That Must Be Observed When Using Reducing Wheels are: (1) *The wheels should be so designed that under*

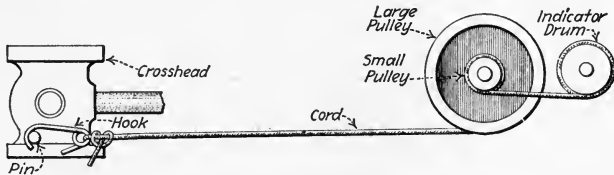

FIG. 66.—Principle of the reducing wheel.

operating conditions the momentum of the moving parts will not become sufficient to produce slackness in the cord at any time.

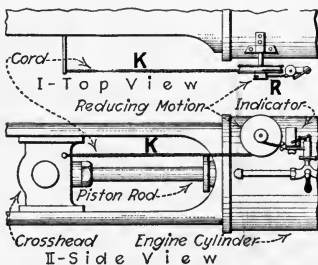

FIG. 67.—Correct method of connecting indicator cord to crosshead.

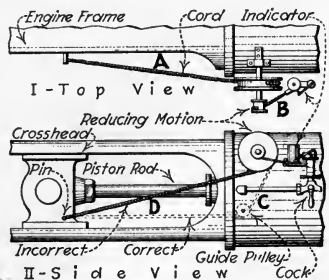

FIG. 68.—Incorrect and corrected methods of connecting indicator cord to crosshead.

(2) *A cord should be used which will not stretch to any appreciable extent.* Nearly all indicator manufacturers can furnish reduc-

ing wheels and cords which will satisfy the above requirements and which are applicable to different types and sizes of engines.

CAUTION.—WHEN USING REDUCING WHEELS always see that the cord (Figs. 67 and 68) from the crosshead to the wheel is practically parallel to the axis of the engine cylinder (*K*, Fig. 67) and that the drum cord leaves its pulley at right angles to the axis of the pulley (*R*, Fig. 67). This will prevent angular distortion of the diagram. Conditions *A* and *B* (Fig. 68) besides causing distortion will tend to make the cord run off the pulleys. Condition *D* will give a very poor reduction but may be remedied either as shown dotted at *C*, or as *K*, Fig. 67.

88. The Inclined-Plane Reducing Mechanism (Fig. 69) gives a very good reduction when the angle through which the

bell-crank, *L*, turns is kept fairly small. The length of diagram is fixed by the inclination of the plane, *P*, and the lengths of the two arms of the lever, *L*. The upright arm can be of such length as to bring the cord in line with the indicators. A catch, *C*, (Fig. 69)

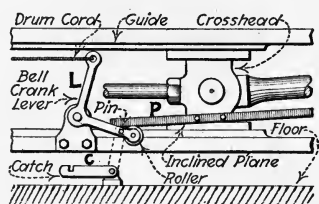

FIG. 69.—Inclined-plane reducing mechanism.

can be arranged to hold the roller free of the plane and thereby stop the indicator without unhooking the cord. This, at the same time, prevents flapping of the cord.

89. Every Indicator Reducing Motion Should Be Given Two Tests Before Using: (1) *Test for accuracy of reduction.* First divide the stroke of the crosshead into eight equal parts (Fig. 70). Attach an indicator, without a spring, to the cylinder. Now, with the indicator attached to the reducing motion and the crosshead at zero, make a vertical mark on the indicator card by raising the pencil lever. Then move the crosshead successively to positions 1, 2, 3, etc., making a vertical mark on the indicator card for each position. If the spaces between the lines on the card are equal, the reduction is satisfactory. (2) *Test for lost motion and inertia or momentum effects.* Now run the engine *slowly* and take an "atmospheric line" (Sec. 100), holding the pencil on during a complete revolution. Let the engine get up to speed and take another line about $\frac{1}{16}$ in. above the first. A considerable difference

in the lengths of the two lines, indicates momentum effects in the reducing mechanism or the drum itself, or stretching of the cord. The remedies are taking up all lost motion, using a short cord or a wire, and so adjusting the drum spring that the discrepancy will be a minimum.

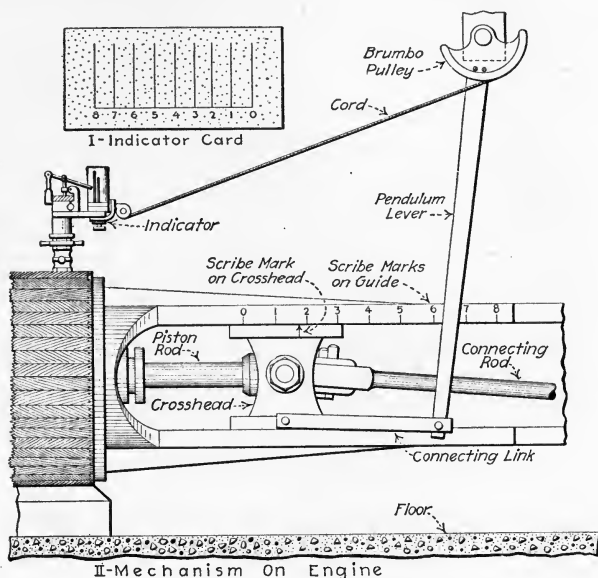

FIG. 70.—Method of testing reducing mechanism for accuracy of reduction.

90. In Piping For Indicators, great care must be taken that the pipe is of sufficient size to allow the steam to flow through it without throttling (reducing the pressure) and that the pipe has not sufficient volume to affect the working of the engine by increasing its clearance volume.

NOTE.—THE BEST METHOD OF PIPING AN INDICATOR is to drill and tap directly into the counterbore of the engine for $\frac{1}{2}$ -in. pipe, as at *A*, Fig. 71. If the counterbore is too short it is well to chip a channel into the cylinder. Of course, all chips must then be removed from the cylinder to prevent injury to it and the indicator. Where no steam pipes or other obstructions appear at the top of the cylinder, it is best to locate the indicators there,—otherwise they are mounted on the side of the cylinder. A straight-way indicator cock (*C*, Fig. 71) is then screwed into each tapped hole, preferably without any intermediate piping. The ell

shown below the indicator in Fig. 65 can well be omitted so that the indicator drum will extend out horizontally from the cylinder.

NOTE.—ALL INDICATOR COCKS SHOULD HAVE A RELIEF PASSAGE (X, Fig. 55) which will relieve the pressure beneath the indicator piston when cock is in the closed position.

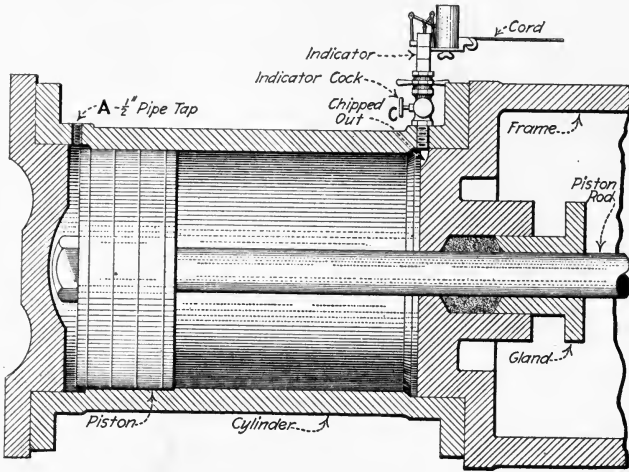

FIG. 71.—Ideal method of connecting an indicator to a cylinder.

91. Using A Single Indicator For Indicating A Cylinder Is To Be Avoided, if possible, but whenever necessary, a three-way

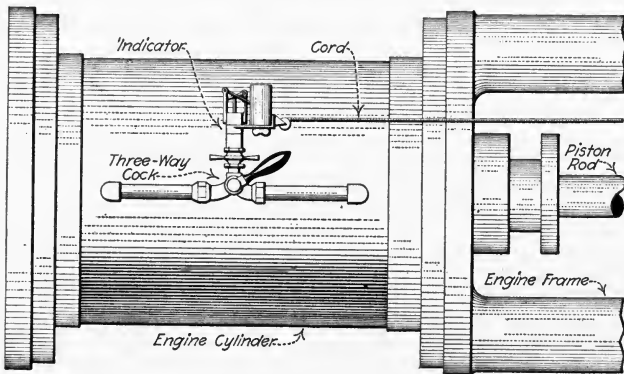

FIG. 72.—Arrangement for using one indicator for both ends of a cylinder.

cock should be used and piped as shown in Fig. 72. The indicator is thrown into communication with one end of the

cylinder and then the other, giving the two diagrams on one card. Diagrams taken with an indicator so arranged cannot be relied on for accuracy because of the time required to fill the pipes with steam up to the pressure within the engine cylinder. The arrangement of Fig. 73 is to be especially avoided, because

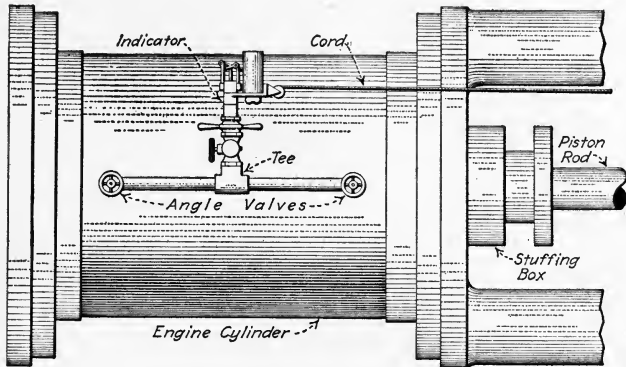

FIG. 73.—Incorrect piping of an indicator.

of the excessive steam volume in the piping and because of errors due to the two valves; if found on an engine, this arrangement should be replaced. The arrangement of Fig. 74 may be safely used where it is essential that provision be made for testing with either one or two indicators.

NOTE.—THE ARRANGEMENT OF FIG. 72 USUALLY GIVES POWER

RESULTS WHICH ARE 3 TO 7 PER CENT. TOO HIGH, although in certain cases it gives results so poor that it is useless. It is well, when using this connection, to compare a diagram so taken with one taken with a direct connection and the engine under the same load.

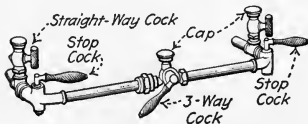

FIG. 74.—Piping arrangement which is adaptable for either one or two indicators.

92. Indicator Springs Are Classified As To Their Stiffness, the *number (or scale) of an indicator spring* being the pressure (in pounds per square inch) which must be exerted upon the indicator piston to raise the pencil one inch. Thus, a 100-lb. spring, when in an indicator, would permit the pencil to be raised 1 in. by a pressure of 100 lb. per sq. in. within the

engine cylinder, 2 in. by a pressure of 200 lb. per sq. in. and so on. Table 93 shows the different springs made by American manufacturers and the maximum safe pressure to which they can be subjected, when used with a $\frac{1}{2}$ -sq. in.-area piston. When used with a $\frac{1}{4}$ -sq. in.-area piston the scale and safe pressure are twice the values shown in the table.

EXAMPLE.—A 50-lb. spring when used with a $\frac{1}{4}$ -sq. in.-area piston becomes a 100-lb. spring with safe pressures of 200 to 240 lb. per sq. in.

NOTE.—SINCE THE SPRING IS THE ACTUAL MEASURING ELEMENT OF AN INDICATOR, great care must be taken that it actually measures as it should. Springs gradually change their stiffness with continued use and should, therefore, be periodically tested, especially before and after being used on important work.

93. Table Showing Safe Pressures For Indicator Springs, the higher values of safe pressure being for engine speeds below 200 r.p.m.; the lower values for speeds up to 300 r.p.m.

Scale of spring, pounds per inch	Safe pressure, pounds per square inch	Scale of spring, pounds per inch	Safe pressure, pounds per square inch
8	5 to 10	60	120 to 140
10	9 to 15	64	130 to 145
12	11 to 20	70	135 to 150
16	20 to 30	72	140 to 160
20	30 to 40	80	160 to 170
24	40 to 50	90	180 to 190
30	55 to 65	100	200 to 215
22	60 to 70	120	225 to 240
40	80 to 95	125	230 to 250
48	95 to 115	150	265 to 300
50	100 to 120	200	325 to 380

94. In Testing An Indicator Spring (Fig. 75), the indicator should be mounted on a vessel, *V*, together with a test gage, *G*, and subjected to steam pressure in 5- or 10-lb. per sq. in. steps, beginning with atmospheric pressure as zero. The cord should be drawn by hand at each pressure to obtain a horizontal line (Fig. 76) about half way along the card. After the pressure has reached the maximum it should be lowered again in the same steps. The line corresponding to a certain pres-

sure may be higher now than before, due to friction within the indicator cylinder. The card, when the test is completed,

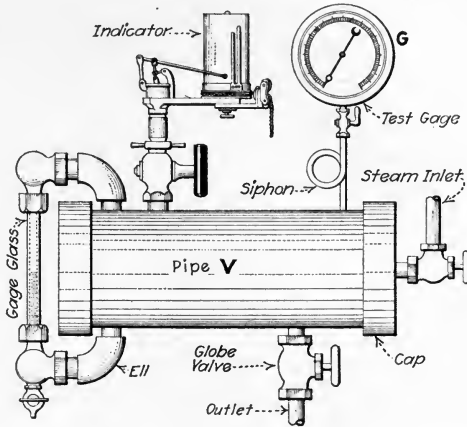

FIG. 75.—Apparatus for testing indicator springs (also gages and thermometers).

should look like Fig. 76. The mean between the two lines drawn at a certain pressure is taken as the average for that

No.	Hour 1:30A. M.	2/3 1921		
Which End			Different Pressures at Which Spring is Tested	Area
B. Press	60			Length
Vac. Gage	50			M. Ord.
Revs.	40			M.E.P.
Spring	40			I.H.P.
	30			
	20			
	10			
			Atmospheric Lines	
Indicator No.	1620			Observer: J.P.B.

FIG. 76.—Sample card illustrating test of an indicator spring.

pressure. The spring scale can then be calculated from each height by substituting in the formula,

$$(8) \text{ Spring Scale} = \frac{\text{gage pressure, in lb. per sq. in.}}{\text{height on card, in inches}}$$

EXAMPLE.—If h , Fig. 76, is measured to be 1.19 in., and is the height to the 50-lb. line, as shown, then: $\text{spring scale} = 50/1.19 = 42 \text{ lb. per in.}$ This value supersedes the manufacturer's scale, which was 40.

NOTE.—MANUFACTURERS WILL TEST INDICATOR SPRINGS, when sent to the factory, for those who lack apparatus for making their own tests. The author, however, recommends the construction and installation in every engine room of an apparatus similar to Fig. 75. Besides testing indicator springs, it is very useful for testing gages and thermometers. The indicator cock can readily be replaced by a gage siphon or a thermometer well. The gage glass is unnecessary except for thermometer testing, in which tests water in the glass insures saturated steam.

95. In Selecting Springs For Indicating An Engine, bear in mind that the larger the diagram taken, the less will be the percentage error in making calculations from it. There are, however, certain limitations to this policy. On high-speed engines, large diagrams are likely to be accompanied by inertia effects in the indicator and its mechanism, which would introduce errors offsetting the advantages of the large diagrams. If too light a spring has been selected, these effects will appear on the indicator diagram as in Fig. 77, *A* and *B*, and call for a stiffer spring.

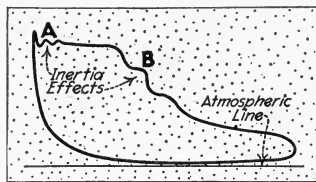

FIG. 77.—Inertia effects in indicator diagram caused by too weak spring.

NOTE.—IN GENERAL, THE PROPER SPRING MAY BE SELECTED IN ADVANCE by one of the following rules, which are based on a diagram not over $1\frac{3}{4}$ in. in total height:

For non-condensing engines (or cylinders),

$$(9) \text{ spring scale} = \frac{\text{pressure at steam valves}}{1\frac{3}{4}} \quad (\text{lb. per in.})$$

For condensing engines (or cylinders),

$$(10) \text{ spring scale} = \frac{\text{pressure at steam valves} + \frac{\text{vacuum in condenser}}{2}}{1\frac{3}{4}} \quad (\text{lb. per in.})$$

Wherein: *Pressure at steam valves* is in pounds per square inch, gage. *Vacuum in condenser* is in inches of mercury column. Since the vacuum in the condenser is usually between 25 and 30 in. of mercury, For (10) may be simplified to:

$$(11) \text{ spring scale} = \frac{\text{pressure at steam valves} + 15}{1\frac{3}{4}} \quad (\text{lb. per in.})$$

EXAMPLE.—A compound engine is operating under the following

pressures: Pressure at throttle, 200 lb. per sq. in. gage. Pressure in receiver, 4 lb. per sq. in. gage. Vacuum in condenser, 27 in. of mercury column. Find spring scales. SOLUTION.—Applying For. (9) for the high-pressure cylinder: *spring scale = pressure at steam valves*/ $1\frac{3}{4} = 200 \div 1\frac{3}{4} = 114\frac{2}{7}$ lb. per in. Hence a “120-lb.” spring should be used. Now applying For. (10) for the low-pressure cylinder: *spring scale = (pressure at steam valves + $\frac{1}{2} \times$ vacuum in condenser)*/ $1\frac{3}{4} = (4 + \frac{1}{2} \times 27)/1\frac{3}{4} = 17.5 \div 1.75 = 10$ lb. per in. Or by applying For. (11): *spring scale = (pressure at steam valves + 15)*/ $1\frac{3}{4} = (4 + 15) \div 1\frac{3}{4} = 19 \div 1.75 = 10\frac{6}{7}$ lb. per in. A 10- or 12-lb. spring might be used here.

CAUTION.—ALWAYS USE A STIFFER SPRING THAN COMPUTED rather than a weaker spring, thus avoiding the possibility of the pencil rising above the top of the drum and catching there.

96. In Placing The Selected Spring In The Indicator one end is fastened *firmly* to its stationary support (Cap, C, Fig. 56, in inside-spring indicators), the other end to the piston (in some indicators to the piston rod).

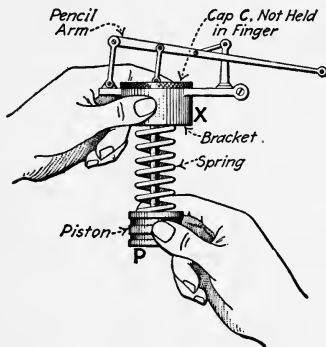

FIG. 78.—Method of adjusting pencil height.

the piston, spring, cap, and pencil mechanism into the indicator body, see that there is no excessive lost motion in the parts (hold cap in one hand and try moving pencil arm with the other) and adjust the pencil to approximately the proper height (Fig. 78). Hold bracket, X, in one hand and turn piston with the other. Then lubricate the indicator piston, P, with a drop or two of cylinder oil, and the pencil mechanism with a very

light machine oil (manufacturers supply porpoise oil) and screw cap, C, into place. If the pencil is too high or low repeat the adjustment until it is correct. *The pencil should be about $\frac{1}{4}$ in. above the bottom of the card if the indicator is used on a non-condensing cylinder. On condensing cylinders it must be high enough so that the vacuum on the exhaust stroke will not draw it quite to the bottom of the card.*

EXAMPLE.—On the low-pressure cylinder of the engine of the example under Sec. 95, the pencil should be about $1\frac{1}{2}$ in. from the bottom of the card.

97. Before Applying An Indicator To An Engine Always Allow Steam To Blow Through The Cock to remove all dust and grit that may have settled there and thereby prevent injury to the finely-finished indicator cylinder. It is well to have caps (Fig. 74) to fit over the indicator cocks when they are not in use to keep out foreign matter. Then connect the drum

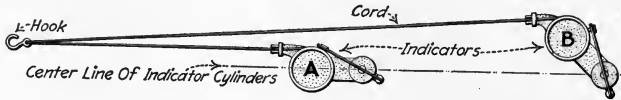

FIG. 79.—Proper arrangement where two indicators, A and B, are operated from one reducing mechanism.

to the reducing mechanism as shown in Fig. 79, and adjust their lengths to get the diagrams in about the centers of the cards. *Try the cord by hand before attaching to the running engine.* Adjust the handle (H, Fig. 53) so that, when pressure is applied to it, a very light line will be made upon the card. Then take pencil from drum and open the cock to see

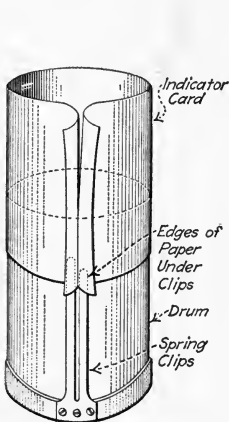

FIG. 80.—Method of starting paper on an indicator drum.

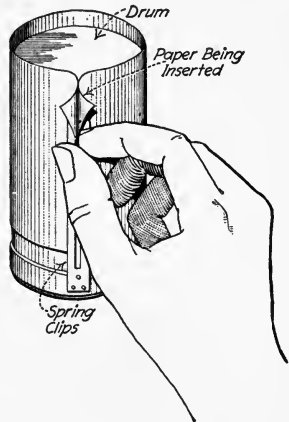

FIG. 81.—Method of placing paper on an indicator drum.

that the pencil will not overtravel the drum either at the top or at the bottom.

98. Indicator Paper should be smooth, tough, and well-calendered, so that it can be handled without damage and that it offers little friction to the passage of the pencil over its

surface. It should be cut to the height of the indicator drum and about 1 in. longer than the circumference of the drum. The paper is put on the drum (Fig. 80) by inserting one corner under the longer clip, bending the card (paper) around the drum and bringing the other corner under the other clip, then pulling it tight around the upper end of the drum. Then, by taking hold of the two corners between the clips, the card is slid down the drum (Fig. 81), pulled tight again around the drum and the ends folded back. A little practice enables one to do this quickly and neatly.

99. The Indicator Pencil should be of hard lead and should be short and kept well pointed. Too long a lead will cause inertia effects in the pencil mechanism. As the point wears down, it must be resharpened by rubbing it on a piece of fine sand paper because a fine line is very essential in indicator work. A metallic point can be used on a *paper coated with sulphate of zinc* and has the advantage of keeping its point although it offers more friction than a lead point.

100. An "Atmospheric Line" Should Be Drawn On Each Card before taking a diagram. It is best drawn by holding the pencil to the card (cock closed) and rotating the drum through a complete revolution by pulling the cord by hand as far as it will go, before attaching the cord to the reducing mechanism. The importance of always taking an atmospheric line cannot be overestimated. Its uses will be brought out in subsequent sections.

101. The Indicator Diagram Is Taken As Follows: (1) *Open indicator cock and allow indicator to "warm up."* (2) *While indicator is warming up, attach drum cord to reducing mechanism.* (3) *Hold pencil to paper for at least three or four revolutions of engine.* (4) *Close cock and unhook drum cord.* (5) *Examine card for evidences of indicator errors.* As connections in the indicator and at the cord are apt to work loose, it is advisable to frequently try the indicator pencil for lost motion and to watch that the diagram remains in the center of the card (to make sure the drum is not striking its stops).

NOTE.—CONVENIENT METHODS OF "HOOKING-UP" AN INDICATOR CORD are illustrated in Figs. 82, 83 and 84. Fig. 85 shows how an adjustable loop may be arranged in an indicator-cord end. Fig. 86 illustrates a

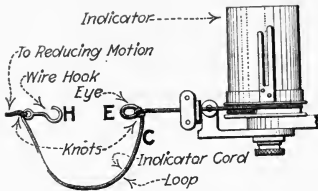

FIG. 82.—Method of arranging drum cord, C, to prevent flapping. (Connection is effected by catching hook, H, in eye, E.)

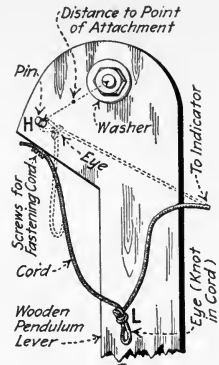

FIG. 83.—Connection at pendulum lever to prevent flapping of cord. (Eye, L, is placed over pin, H.)

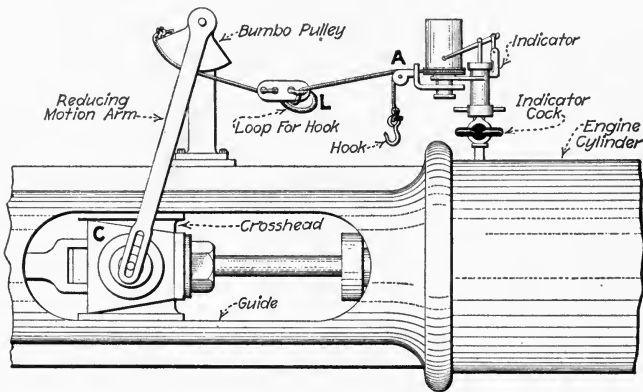

FIG. 84.—Convenient method of arranging an indicator cord. (One end, A, of the cord is attached to the indicator leaving the cord sufficiently long that it will not pull taut when the crosshead, C, is in its extreme position. A loop, L, is provided near the indicator for "hooking in.")

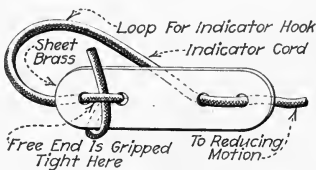

FIG. 85.—Adjustable loop for indicator-cord end.

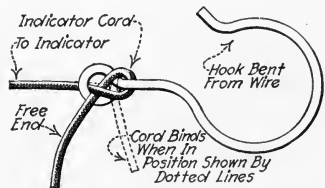

FIG. 86.—Knot for indicator-cord hook whereby effective cord-length can be adjusted readily.

knot, for attaching the cord to the hook, whereby the cord length may be adjusted readily. *Indicator cords* should preferably be high-grade, smooth fish line known in the trade as "trout line." It should be from $\frac{3}{64}$ to $\frac{5}{64}$ in. in diameter. Any smooth cord which has sufficient strength and which will not stretch will do. *Iron wire* between $\frac{1}{64}$ and $\frac{1}{32}$ in. in diameter, is sometimes used instead of cord for operating indicators. No. 22 gage annealed iron wire or picture wire may prove satisfactory. Kinks may be taken out of iron indicator wire as suggested in Fig. 87.

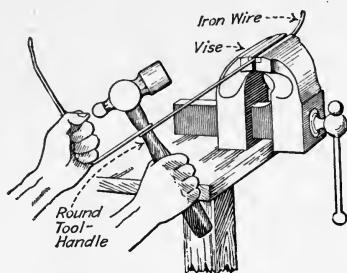

FIG. 87.—Taking kinks out of No. 22 gage annealed iron indicator wire.

taken out of iron indicator wire as suggested in Fig. 87.

102. An Ideal Indicator Diagram is shown in Fig. 88. This diagram is for an engine having a stroke of 32 in., cutting off when the piston has traveled 8 in. from the beginning, and the exhaust valve opening 2 in. before the end of the stroke. It is assumed that the exhaust valve closes 5 in. before the end of

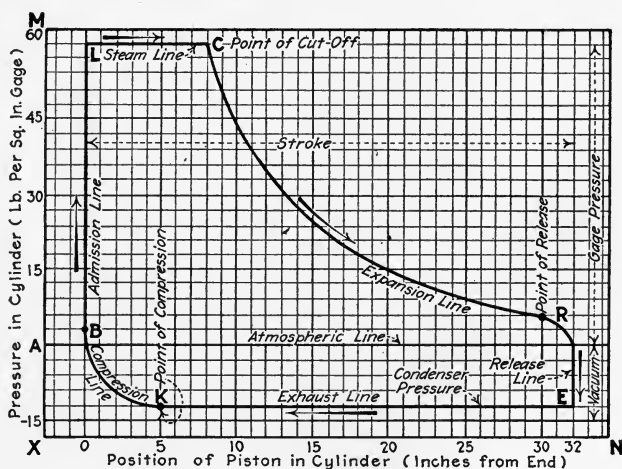

FIG. 88.—Ideal indicator diagram for a steam engine.

the return stroke and that the steam valve opens when the piston is exactly at the end. The engine is supplied with steam at 60 lb. per sq. in. gage, and exhausts into a condenser where the vacuum is 12 lb. per sq. in. (about 24 in. mercury

column). A vertical scale of pressures, XM , (Fig. 88) and a horizontal scale, XN , representing positions of the piston are laid off on the squared paper. While the piston travels its first 8 in., the pressure, LC , inside the cylinder will, of course, be 60 lb. per sq. in. because the steam valve is open. The steam then expands along a line, CR , until the exhaust valve opens at R , where the pressure drops rapidly, RE , to that in the condenser. On the return stroke of the piston the pressure, EK , remains that of the condenser until the exhaust valve closes (K). Then the steam which remains in the cylinder is compressed (KB) and finally, when the piston reaches the end of its travel, steam is again admitted (B) from the boiler and the pressure in the cylinder immediately rises, BL , to the pressure of the steam supply.

NOTE.—THE EXACT FORM OF THE COMPRESSION AND EXPANSION LINES depends upon the clearance volume and will be treated separately (Secs. 108 and 111).

103. The Actual Indicator Diagram Differs Widely From The Theoretical (except in occasional instances) for various reasons: (1) *The valves may not be set to give the best diagram.* (2) *The engine design may not allow of a perfect diagram even with the valves in their best setting.* (3) *The installation of the engine may be at fault.* However, the indicator diagram enables one to intelligently set the engine valves and to know why a more perfect diagram is not obtained. In studying the diagram, each "line" of Fig. 88 will be considered separately.

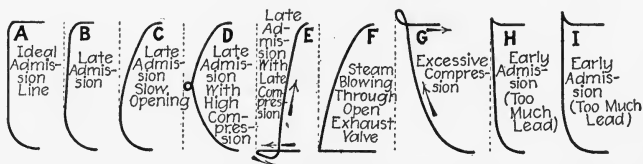

FIG. 89.—Variations of the admission line.

104. The "Admission Line" Will Be Of Varied Appearance for different engines. BL (Fig. 88) and A , Fig. 89, show the ideal form in which it often appears on cards from slow-speed four-valve engines. On high-speed engines the admission line

(Fig. 90) is frequently lacking altogether, a condition which is often satisfactory. If the steam valve opens late in the cycle but still opens rapidly, admission line *B* (Fig. 89) will result. With slow opening this changes to the form of *C*. Notice, here, that the piston travels outward before the valve is well opened, increasing in speed as it progresses, and that the steam does not get a chance to build up the pressure until the piston is well on in its stroke. Condition, *D*, occurs when the compressed steam in the clearance volume begins to expand before the steam valve opens. Condition

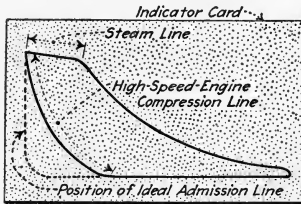

FIG. 90.—Indicator diagram from a high-speed engine. (Showing absence of admission line.)

E happens seldom; here the exhaust valve closes just at the end of the return stroke and the piston, moving outward, then expands the steam in the clearance volume, reducing its pressure until the steam valve opens allowing the pressure to build up. Condition *F* represents what happens to the admission line when the steam valve opens at the proper time but the exhaust valve remains open too long. With condition *G*, representing too-high compression, the opening of the steam valve allows the steam to flow out of the cylinder and into the steam chest until this is again expanded by the piston moving outward. Just as late admission, *C*, causes the admission line to slope away from the end, so an early admission causes it to slope backward, as *H*. In condition *I*, the sharp point at the top is another indication of early admission. Decreasing the lead (see Divs. 4 and 5) will usually make the engine run more smoothly and give a rounded top as in *A*.

105. The "Steam Line" Indicates The Pressure Losses (*LC*, Fig. 88 and Fig. 91) from the boiler to the engine cylinder and depends on the steam-flow through all the intermediate passages.

EXPLANATION.—Just as water will flow only from a higher to a lower level, so will steam flow only when there exists a difference of pressure to cause the flow. The greater the velocity of the steam through the passages and the greater the internal surface area, in the passages, over which the steam must pass or rub, the greater, of course, will be the

amount of frictional resistance produced by the steam passing through the passages. The greater the frictional resistance, the greater again must be the difference of steam pressure to maintain the flow.

Now, in a steam engine, the steam is first admitted when the piston is about at the end of its stroke and moving very slowly. The volume to be filled with steam is only the clearance volume, which can be filled quickly and usually with a small steam velocity through the ports. But the velocity of the piston increases as it moves toward mid-stroke and then decreases again. As the piston moves from the end, steam must rush in to fill a rapidly increasing volume and, the faster the volume increases (piston travels), the more swiftly the steam must flow through the ports. Thus, as the piston moves away from the cylinder end, there will be a rapidly increasing frictional resistance in the passages—calling, in turn, for a greater pressure difference between the boiler and cylinder.

106. The Ideal Steam Line (BL, Fig. 88 and A, Fig. 91) can only be produced when the velocity of the steam through the passages never becomes great enough to appreciably

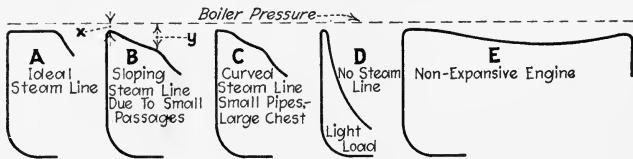

FIG. 91.—Variations of the steam line.

affect the frictional resistance. This may occur in a very slow-speed engine with large direct passages. The ideal steam line is very nearly approached in most Corliss engines. In high-speed engines, the steam line looks more like B, Fig. 91, where the difference between x and y represents the additional pressure required to force the steam into the cylinder at the higher velocity after the piston leaves the end. On engines with large steam chests the steam line will appear more as shown at C, where the steam stored in the chest is able to keep up the pressure in the cylinder until the piston has moved farther out in its stroke and attained a higher velocity. Diagram D represents the total absence of a steam line at light load, cut-off having taken place as soon as the clearance volume was filled with steam. Diagram E shows the variation in pressure-drop in a non-expansive engine as the speed of the piston increases and again decreases toward the end of the

stroke. The same sort of line is usual where an engine has a very late cut-off point.

107. **The Steam-Chest Diagram** (Fig. 92), when combined with the cylinder diagrams, is very valuable for segregating the pressure losses between the boiler and the cylinder. The steam-chest diagram is taken on an indicator which is piped to the steam chest and which is driven from the same reducing mechanism as that which is used for the cylinder diagrams. The cylinder diagrams are taken on another card (or combined, by tracing the diagram from one end onto

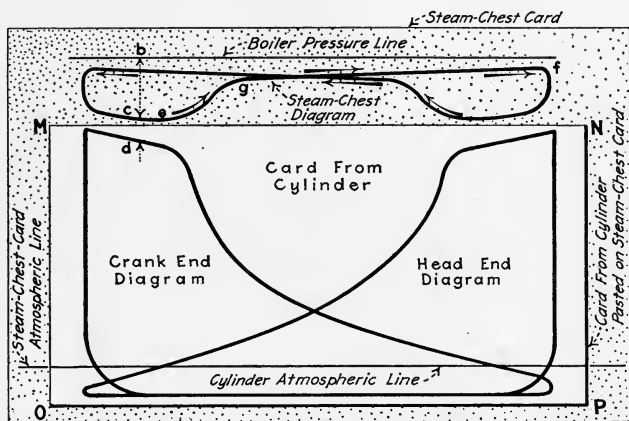

Fig. 92.—Cylinder diagrams superimposed on steam-chest diagram.

that from the other end). *The cylinder diagrams and steam-chest diagram must be taken with the engine operating under like conditions.* The card with the cylinder diagrams is then cut down in size and pasted on the steam-chest diagram with the atmospheric lines along one line and with the ends of the diagrams above one another as shown in Fig. 92. The boiler-pressure line is then drawn on the card by hand at a height measured from the atmospheric line by the same scale as that of the spring with which the diagrams were taken.

EXPLANATION.—When the crank-end steam valve opens (Fig. 92) the pressure in the steam chest is reduced. As the piston moves away from the end, the pressure in the chest decreases as does also the pressure in the cylinder. Up to cut-off, *e*, the drop between the boiler and steam chest, *bc*, and the drop from the chest to the cylinder, *cd*, both increase

because of the increasing velocity of the steam. After cut-off, however, steam is supplied from the boiler only to fill the steam chest, and it builds up the pressure there rapidly at first (*eg*) and then more slowly (*gf*) until the head-end valve opens, again causing the pressure to drop. Sometimes the momentum of the steam in the supply pipe causes the point *g* to appear much higher than shown. Line *gf* is then practically parallel to the boiler-pressure line.

NOTE.—DISTANCE *bc* CAN OFTEN BE DECREASED and the entire steam-chest diagram flattened out by equipping an engine with a larger supply pipe. Likewise, distance *cd* can sometimes be decreased by increasing, if possible, the amount by which the valve uncovers the steam port.

108. The "Expansion Line" In A Steam Engine Usually

Follows A Hyperbolic Curve (*CR*, Fig. 88 and Fig. 93). That is, the absolute pressure falls inversely as the volume increases. If the volume is doubled, the pressure falls to one half the initial; when the volume is five times the initial, the pressure is one fifth and so on. Thus, Fig. 93 represents the expansion of one cubic foot of steam from an initial pressure of 60 lb. per sq. in. abs. (about 45 lb. per sq. in. gage).

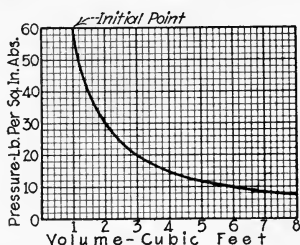

FIG. 93.—Hyperbolic expansion line for steam.

EXAMPLE.—Fig. 94 is an indicator diagram taken with a 60-lb. spring from an engine which has a clearance volume equal to 5 per cent. of the piston displacement. From the point of cut-off draw the theoretical (hyperbolic) expansion line.

SOLUTION.—Since the length of the diagram is 3 in., the clearance volume *OA*, can be represented as 5 per cent of 3 in. = $0.05 \times 3 = 0.15$ in., or $\frac{3}{20}$ in., and laid off to the left of the diagram as shown. The zero pressure line, *OZ*, can also be laid off to scale below the atmospheric line (15 lb. is near enough for atmospheric pressure except when spring scale is very small). To construct the theoretical curve through *C*, the point of cutoff, draw line *CU*, parallel to the atmospheric line and line *CB* perpendicular to it and divide up *BZ* into parts (which may be of any length) *BE*, *EI*, *IM*, *MP*, etc., as shown. Erect a perpendicular at each point of division. Draw lines from the points where these perpendiculars cut the line *CU* to point *O* and note where they cut *CB*. From the points where these diagonal lines cut *CB* draw horizontals again to cut the perpendiculars, as *FG*, *JK*, etc. The points *G*, *K*, *Y*, etc. will determine

the theoretical expansion curve which can then be drawn through them. As is shown, it is well to draw the perpendiculars *DE*, *HI*, etc. closer together for the first part of the expansion curve than for the end, because the curve drops more rapidly at the start.

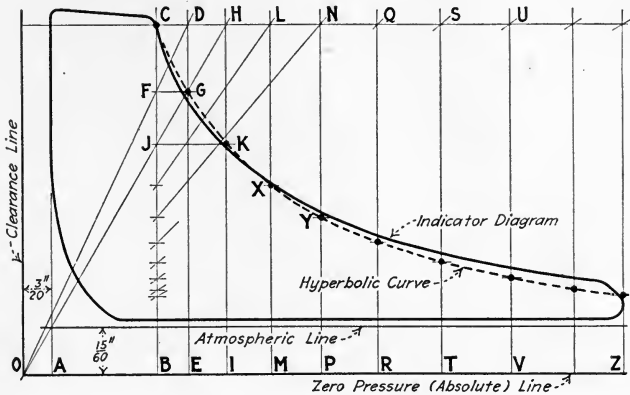

FIG. 94.—Construction of the theoretical expansion line. (Hyperbolic curve.)

109. The Expansion Line May Reveal Leaky Valves (Figs. 95 and 96). With valves properly seated (Fig. 92), the actual expansion curve usually falls below the theoretical at the beginning and rises above it toward the end. A leaky exhaust (or drip) valve may cause the expansion

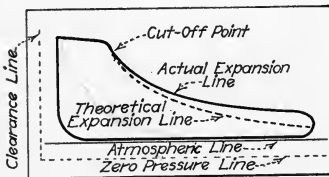

FIG. 95.—Indicator diagram showing effect of leaky steam-admission valve.

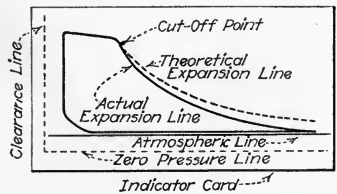

FIG. 96.—Indicator diagram showing effect of leaky exhaust valve.

curve to lie exactly on the theoretical or below it, as in Fig. 96. A leaky steam valve, on the other hand, will cause the expansion curve to lie well above the theoretical throughout its length (Fig. 95).

NOTE.—TOO MUCH SHOULD NOT BE INFERRED FROM THE APPEARANCE OF THE EXPANSION LINE, however, as there are too many things

which might affect its shape. The expansion line may follow the theoretical very closely in an engine that has leaky steam and exhaust valves. Its study is useful chiefly in revealing general indications of trouble.

110. The "Release" and "Exhaust" Lines Indicate How Effectively The Steam Is Taken From The Cylinder (*RE* and *EK*, Fig. 88 and Fig. 97). Since they merge into one another they are difficult to study separately. The release line, one might say, begins at the point of release, *R*, and ends where the pressure is decreased to its minimum value, as at *H*, Fig. 97. The exhaust line (also called the *back-pressure* or *counter-pressure line*) begins at *H* and ends at *K*, the point of compression, where the exhaust valve closes. Since the pressure in the cylinder during exhaust must, to produce a flow, be more than that into which the cylinder is exhausting, the exhaust line may be expected lie above the atmospheric (when exhausting to the atmosphere). If the exhaust pas-

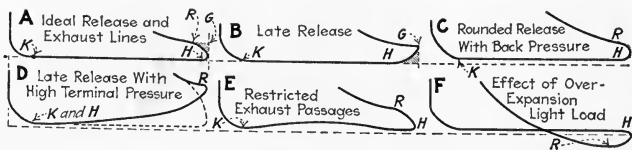

FIG. 97.—Variations of release and exhaust lines.

sages are short, direct, and large, the pressure difference will not, *A* and *B*, be noticeable on the indicator diagram.

As it is advisable to have the pressure, urging the piston forward, decrease toward the end of the stroke, a release line as at *A* is recommended. Of course the maximum of work would be obtained from the steam if it were released along the line *GH* of *A* but this would result in condition *B* in which the loss of work (shaded) is the same as in *A*. The mean between these two conditions is represented in *C*. With a high terminal-pressure condition *B* takes the shape of *D*, due to the inability of the exhausted steam to escape from the cylinder because it is expanding while the volume in the cylinder is decreasing. The dotted line in *D* shows the advantage of the early release.

Condition *E* represents what may happen to the exhaust line if the exhaust valve restricts the port when it is in its

extreme position (too much lap); this condition might also appear in a twin-cylinder engine where the cranks are set at 90 deg., the hump being formed while the other cylinder is releasing. If cut-off occurs too early in the stroke, the steam may expand to a pressure below exhaust pressure, F , in which case the opening of the exhaust valve allows previously exhausted steam to flow back into the cylinder. As will be shown (Sec. 114), this over-expansion represents a loss of work. Over-expansion can be overcome by throttling the steam supply, thus causing a later cut-off.

111. The "Compression Line" Varies Widely In Different Engines (*KB*, Fig. 88 and Figs. 98 to 100) depending on the valve setting, condition of the engine, exhaust pressure, and the clearance volume. In general, it should be the converse of the expansion line, that is, it should also be a hyperbolic curve, the pressure rising as the volume within the cylinder is decreased. The purpose of this increased pressure at the end of the stroke is primarily to aid in stopping the piston before its reversal in direction of travel, but by thus trapping some steam in cylinder, the amount which must (when the steam valve opens) be introduced to fill the clearance volume is

materially decreased. To completely fill the clearance space, the compression line would have to raise the pressure to that of the steam line as in Fig. 90; but, since this would be more compression than is necessary for stopping the piston, it is

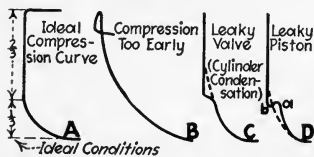

FIG. 98.—Variations of the compression line.

recommended that there should be just enough compression to produce smooth running of the engine.

Usually this condition is brought about when the compression curve merges with the admission line at about $\frac{1}{2}$ the height of the diagram (*A*, Fig. 98). In automatic engines the compression depends upon the load and at light loads frequently becomes excessive as at *B*. Condition *C* may be caused by the condensation of the cushion steam on the cool walls of the clearance space, but it is more likely to be the result of a leaky exhaust or drip valve. Thus as the movement

of the piston becomes slower and the pressure higher, the steam escapes as fast as the moving piston tends to compress it. Condition *D* shows how, with a leaky piston, the compression curve is above the hyperbolic (due to steam leaking in from the other end) up to point *a*, where release occurs at the other end, falling then from *a* to *b*, while leakage takes place to the other side of the piston.

NOTE.—FIG. 99 SHOWS THE EFFECT ON COMPRESSION OF DIFFERENT EXHAUST PRESSURES in the same engine. It is evident that the pressure at the end of compression increases in direct proportion to the exhaust

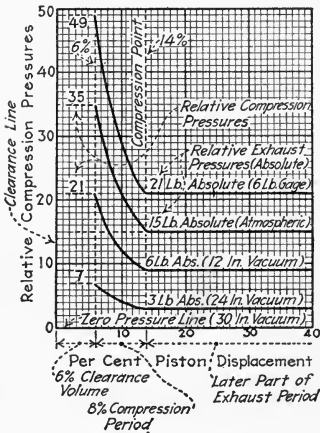

FIG. 99.—Illustrating effect of exhaust pressure on compression. (Compression pressure, for any given engine, varies directly with the exhaust pressure.)

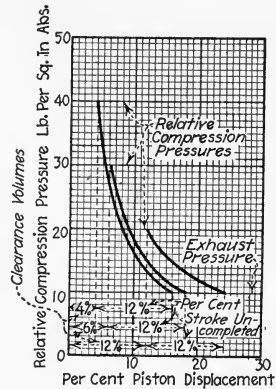

FIG. 100.—Illustrating effect of different clearance volumes on the compression curve.

pressure. That is, if the exhaust pressure (absolute) is doubled the compression pressure is also doubled, and so on. Fig. 100 shows how the compression pressure varies, with the same setting, on engines with different clearances. It is evident from Fig. 100 that if the clearance volume is equal to the portion of the return stroke which is uncompleted when the exhaust valves closes, the compression pressure will be twice the absolute exhaust pressure. If the clearance were but half as great, everything else remaining equal, the compression pressure would be 3 times the exhaust pressure. From this it is evident that in engines with very small clearance volumes the exhaust valve must close late in the stroke or a high compression pressure will result.

112. Examples Of Indicator Diagrams Revealing Faults are included here to better familiarize the reader with their

analysis. Methods of correcting faulty valve-settings will be discussed in Divs. 4 and 5. Methods of correcting mechanical faults will be treated in Div. 13.

EXAMPLE.—Fig. 101 is a card taken from a simple, high-speed engine. The sloping admission lines at *a* and *c* show late admission. Cut-off in the head end at *b* shows a lower pressure than in the crank end at *d*. This, together with the earlier cut-off at *b*, indicates that the port is not well uncovered at the head end to allow the steam to enter. Although

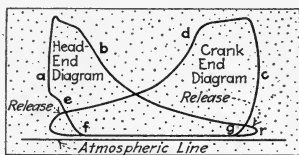

FIG. 101.—Example of faulty indicator diagrams from a simple engine.

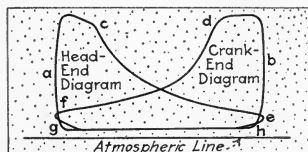

FIG. 102.—Example of faulty indicator diagrams from a simple Corliss engine.

release, *r*, is not too late, it could well be advanced a little. At *f* the uncompleted portion of the return stroke is about twice that at *g*. Although *g* occurs too early, *f* is even worse in this respect. This may account for the curving-off of the compression line at *e* due to cylinder condensation at the high pressure.

EXAMPLE.—Fig. 102 is a card taken from a simple Corliss engine. Late admission is again shown at *a* and *b*. The sloping steam line toward *c* shows only partial valve opening. Late release is shown at *e* and *f*. Compression takes place a little late at *g*, whereas it is satisfactory at *h*.

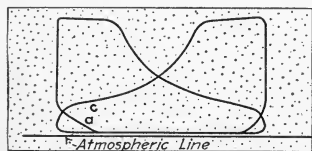

FIG. 103.—Indicator card from a simple Corliss engine.

EXAMPLE.—Fig. 103 shows diagrams which are satisfactory except for the compression curve at *a*. An effort has been made here to obtain compression by closing the exhaust valve early in the return stroke but the steam leaks out as the pressure is raised. Since the pressure at *a* is less than at *c*, the leak is not at the piston and must be at the exhaust valve or drain cock.

113. In Determining The Horse Power Or Steam Consumption Of An Engine The "Mean Effective Pressure" Must Be Known, for reasons which will be explained. But first the methods of finding mean effective pressure will be discussed.

114. In Finding The Mean Effective Pressure By The Method Of Ordinates (Figs. 104 to 106) the length of the diagram is divided into ten equal parts and perpendiculars are

erected at the middle point of each division. The length of each perpendicular is measured or the pressure which it represents is found by a scale corresponding to the spring number. The average height or average pressure is then found as explained below. The use of lengths is better than that of

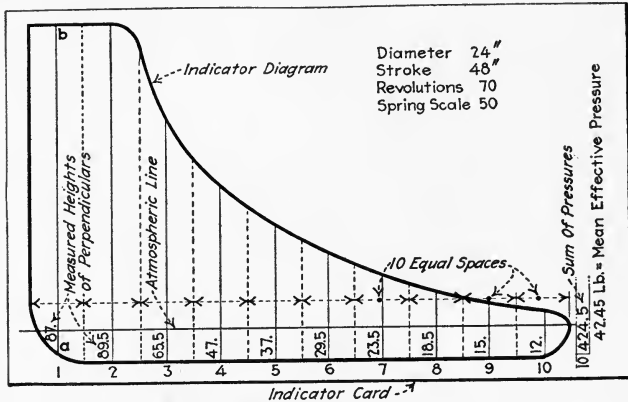

FIG. 104.—Finding P_m by the method of ordinates.

pressures because it permits of correction for the true spring scale (Sec. 94).

EXAMPLE.—Fig. 104 illustrates the method of measuring the pressure along each perpendicular. (Scales to correspond to those of indicator springs can be had from indicator manufacturers.) The length of each perpendicular is measured and written at its foot; for example, with a 50 scale, the length of ab is 87. The ten pressures are then added and the sum divided by ten. The result is the “mean effective pressure” which in Fig. 104 is 42.45 lb. per sq. in.

NOTE.—A CONVENIENT WAY TO ERECT THE TEN PERPENDICULARS (Fig. 105) is to first draw vertical lines AC and BD at the ends of the diagram, then lay a ruler with the zero and 5-in. marks on these lines and place a dot at each $\frac{1}{4}$ - and $\frac{3}{4}$ -inch mark as shown, and later erect perpendiculars through each dot as indicated.

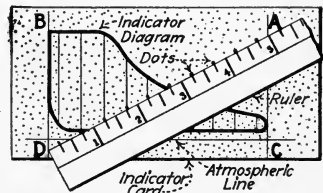

Fig. 105.—Locating mid-points for finding P_m by the method of ordinates.

EXAMPLE.—Fig. 106 shows a convenient method of adding the lengths of the perpendiculars on the edge of a strip of paper. The paper is placed in position I , with its edge along the first perpendicular and with its

corner at the lower end of the perpendicular, and a mark, 1, is made on the paper at the upper end of the perpendicular. This mark is then placed (Position II) at the lower end of the second perpendicular and mark 2 is made at the upper end. This is continued until the ten

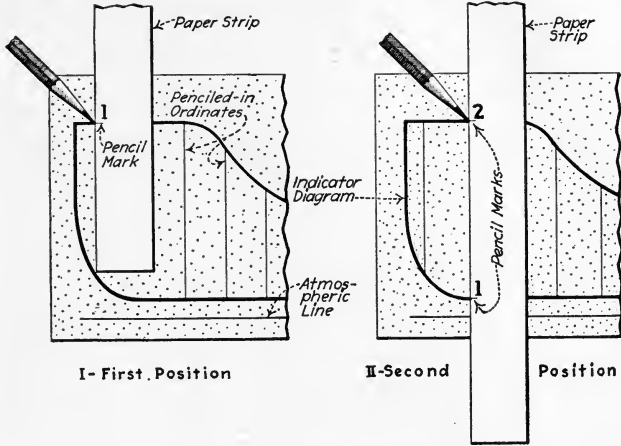

FIG. 106.—Adding lengths of perpendiculars on a paper strip.

perpendiculars have been laid off. The length of the strip of paper from its end to mark 10 is then the sum of the lengths of the perpendiculars, which can be divided by 10 to get the average length. The average

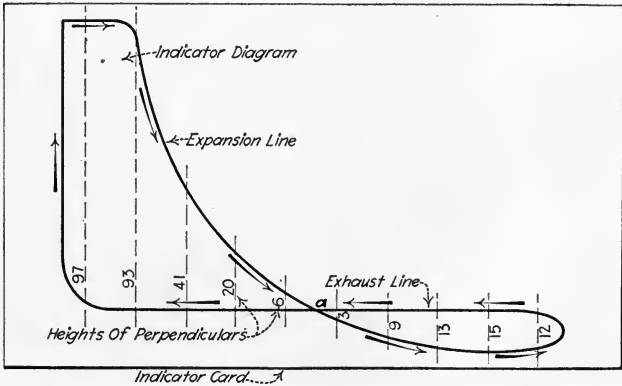

FIG. 107.—Finding P_m , when over-expansion takes place, by the method of ordinates.

length multiplied by the "true scale" of the indicator spring gives the mean effective pressure.

NOTE.—IN CASES OF OVER-EXPANSION (Fig. 107) after point a is passed, the forward pressure on the piston is less than the back pressure

on the return stroke. This means that, instead of being forced forward by the steam, the piston is actually doing work on the steam in expanding it. The loop, therefore, represents work lost during that portion of the stroke. Hence the pressures of the loop must be subtracted from those of the main portion. Adding ordinate pressures for Fig. 107, the *sum of the pressures in the main portion* = $97 + 93 + 41 + 20 + 6 = 257$ lb. per sq. in. The *sum of the pressures in the loop* = $3 + 9 + 13 + 15 + 12 = 52$ lb. per sq. in. The *difference* = $257 - 52 = 205$ lb. per sq. in. Then the *average or mean effective pressure* = $205 \div 10 = 20.5$ lb. per sq. in.

115. The Planimeter Affords A More Accurate Means For Finding The Mean Effective Pressure than does the method of

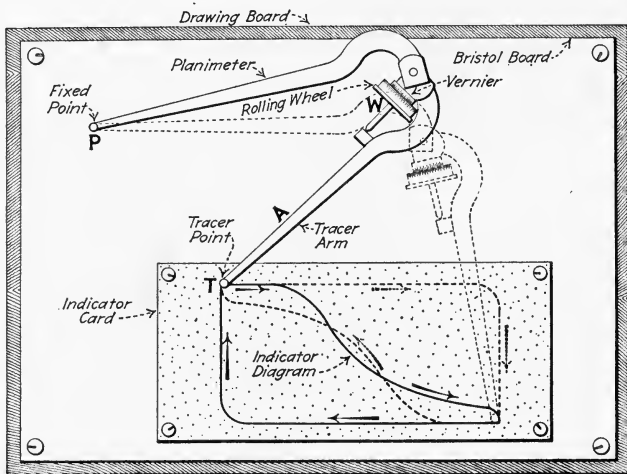

FIG. 108.—Amsler polar planimeter and its correct use in finding areas of indicator diagrams.

ordinates. Generally speaking, a planimeter is an instrument for finding the area of any closed figure. In some of its forms it enables one to find directly the average height of an indicator diagram or even the mean effective pressure.

116. The Amsler Polar Planimeter (Fig. 108) is one of the most simple and enables one to find the area enclosed by the indicator diagram by guiding the tracer point, *T*, around the diagram in a clockwise direction. The planimeter measures the area in square inches.

OPERATION.—The indicator card should be fastened with thumb tacks to a smooth board and on a piece of drawing paper or Bristol board which

is large enough to include the card and the planimeter in every position it will take. The fixed point, *P*, should be so placed that the planimeter arms will not be closed when *T* is nearest to *P* and that the arms will not open too nearly into a straight line when in their maximum position (Fig. 108 shows a good position). The point, *T*, is then placed at some point on the diagram and a slight pressure applied to it so as to make a depression in the card at that point. The reading of the wheel, *W*, and the vernier is then recorded. The point, *T*, is then guided carefully around the diagram in the clockwise direction, as shown, until the depression is again reached. Another reading of the wheel and vernier is taken. The difference between the two readings will be the area of the diagram. The length of the diagram is then measured between perpendiculars erected at the ends (*AC* and *BD*, Fig. 105). The area of the diagram divided by its length gives its mean height. The product of the mean height and the true scale of the indicator spring is the mean effective pressure.

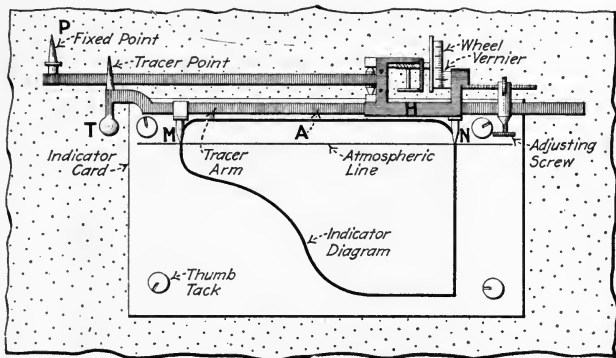

FIG. 109.—Diagrammatic illustration of polar planimeter with adjustable arm for finding mean height of indicator diagrams.

NOTE.—WHENEVER THE DIAGRAM IS SO LOW ON THE CARD THAT THE WHEEL MIGHT CROSS THE EDGE OF THE CARD, the card should be inverted into the position shown dotted in Fig. 108.

EXAMPLE.—An indicator diagram, taken with a 60-lb. spring, is found by planimetry to have area of 1.05 sq. in. and is $3\frac{1}{2}$ in. long. What is the mean effective pressure? SOLUTION.—*Mean effective pressure* = $(1.05 \div 3\frac{1}{2}) \times 60 = 20$ lb. per sq. in.

117. Polar Planimeters With Adjustable Tracer Arms (Fig. 109) are *averaging planimeters*; that is they have the advantage that they will measure the average or mean height of a diagram *directly* on the wheel and vernier (usually in fortieths of an inch). To accomplish this the tracer arm, *A*,

which slides in or out through H , must be so set that the distance between M and N is equal to the length of the indicator diagram.

118. The Coffin Planimeter Is Also An Averaging Instru-

ment (Fig. 110). The indicator diagram is placed with its atmospheric line along the horizontal clip, K , and ends almost touching the fixed and movable vertical clips, F and S . It is then planimeted as with the Amsler planimeter. If the start and finish point is selected at the extreme right of the diagram (G , Fig. 110), the final reading of the wheel and vernier need not be taken. The tracer point can be moved up vertically along the movable clip, S , with the operator keeping his eye on the vernier until the reading of the wheel is

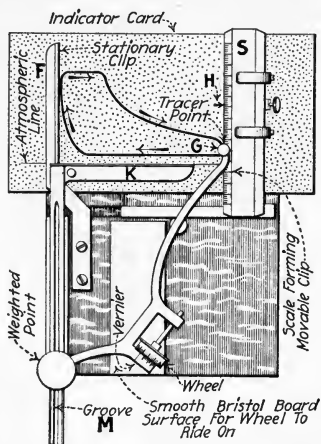

FIG. 110.—Coffin planimeter. (Ashcroft Mfg. Co.)

the same as before tracing the diagram. Assume that this condition obtains when the tracer point reaches H . Then the height, GH , is the mean height of the diagram. If the scale,

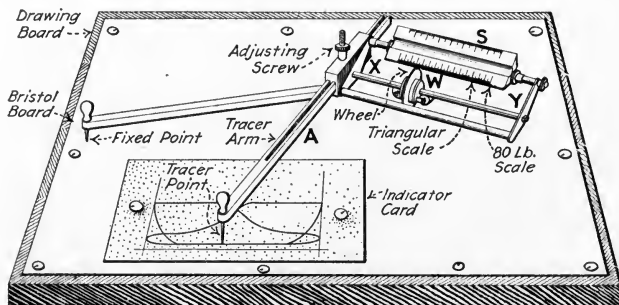

FIG. 111.—Willis planimeter with adjustable tracer arm. (Jas. L. Robertson and Sons.)

S , which forms the moving clip, is the same as the number of the spring, and if its zero be set at G , the mean effective pressure, in pounds per square inch can be read off directly at H .

119. The Willis Planimeter (Fig. 111) has a wheel, W , which moves longitudinally along its axis, XY , a distance proportional to the area circumscribed by its tracer point, T . The movement of the wheel will give the mean effective pressure *directly*, if the length of the tracer arm, A , is equal to the length of the diagram, and if scale, S , is of the same number as that of the indicator spring.

120. In Computing Horse Power From Indicator Diagrams, there are briefly four steps: (1) *Find the horse power constants, k , for 1 lb. mean effective pressure and 1 r.p.m., for each end of each cylinder.* (2) *Find the mean effective pressures from indicator cards, for each end again.* (3) *Find horse power for each end.* (4) *Find total horse power of engine.*

The theory of the computation of indicated horse power from indicator diagrams is treated in Sec. 18. As developed there:

$$(12) \quad P_{ihp} = \frac{P_m L_{fs} A_{ip} N}{33,000} \quad (\text{horse power})$$

Wherein:— P_{ihp} = indicated horse power developed in one end of the cylinder. P_m = mean effective pressure, in pounds per square inch. L_{fs} = length of stroke, in feet. A_{ip} = area of piston, exclusive of rod, if rod extends through the head, in square inches. N = speed of engine shaft, in revolutions per minute.

121. The Horse-Power Constant, k , is made up of the terms that cannot change in For. (12). These are evidently L_{fs} , A_{ip} , and the denominator (33,000). P_m and N will depend upon operating conditions—load, steam pressure, etc. If the latter are each taken equal to one, For. (12) becomes

$$(13) \quad P_{ihp} = \frac{L_{fs} A_{ip}}{33,000} = k \quad (\text{horse power constant})$$

Wherein: k is the horse power constant for a certain end of an engine cylinder = h.p. for 1 lb. mean effective pressure and 1 r.p.m.

EXAMPLE.—An engine has a stroke of 30 in., a piston 18 in. in diameter, and a $2\frac{1}{8}$ in. diam. piston rod. What are its horse power constants?
SOLUTION.—For head end of cylinder: $A_{ip} = 18 \times 18 \times 0.7854 = 254.5$ sq. in.; $L_{fs} = 2.5$ ft.; $k = 2.5 \times 254.5/33,000 = 0.0193 = 1/51.8$.

For crank end of cylinder: $A_{ip} = 254.5 - (\text{area of piston rod}) = 254.5 - 3.547 = 251$ sq. in.; $k_2 = 2.5 \times 251/33,000 = 0.019 = 1/52.6$.

NOTE.—To avoid the use of decimal fractions, it is convenient to use the horse power constant expressed as a fraction whose numerator is one.

122. Methods Of Finding The Mean Effective Pressure, P_m , Have Already Been Given, Secs. 114 to 119. It may be well here to lay down two rules for use when P_m is not found directly.

$$(14) \quad P_m = \frac{\text{area of diagram in sq. in.} \times \text{scale of spring in lb. per in.}}{\text{length of diagram in inches}} \quad (\text{lb. per sq. in.})$$

Or:

$$(15) \quad P_m = \text{mean height of diagram in in.} \times \text{scale of spring in lb. per in.} \quad (\text{lb. per sq. in.})$$

123. To Find The Horse Power For Each End Of One Cylinder one needs only to multiply the horse power constant by the mean effective pressure for that end and by the speed.

Or:

$$(16) \quad P_{ihp} = P_m N k \quad (\text{horse power})$$

EXAMPLE.—In the engine of the example of Sec. 121, if P_m for the head end were 49 lb. per sq. in., for the crank end 53 lb. per sq. in., and if $N = 105$ r.p.m., what horse power is developed in each end? SOLUTION.—For head end, substituting in For. (16), $P_{ihp} = P_m N k_1 = 49 \times 105 \times 0.0193$ or $49 \times 105 \div 51.8 = 99.3$ h.p. For crank end, $P_{ihp} = P'_m N \times k_2 = 53 \times 105 \times 0.019$ or $53 \times 105 \div 52.6 = 105.8$ h.p.

124. The Horse Power As Computed From The Indicator Diagrams Is Called The Indicated Horse Power and represents the power *actually developed* by the steam within the engine cylinder (Sec. 11). Since some portion of this power is lost by friction within the engine, as at the several bearings and sliding members, all of it cannot be realized from the engines for further work.

125. "Friction Horse Power" Is That Part Of The Indicated Horse Power Which Is Lost Within The Engine Itself

(Sec. 11). With a given engine, the magnitude of the friction horse power depends upon the load and the steam pressure but changes only slightly under the varying conditions. If the engine is unbelted or uncoupled from all its load, then *all* the power developed by the steam (indicated horse power) becomes friction horse power.

126. The Brake Horse Power Is The Power That The Engine Delivers, at its shaft, or pulley to some other machine (Sec. 11). It is, of course, less than the indicated horse power by the amount of the friction horse power. Where an engine is driving an electric generator the efficiency of which is known (and in certain other cases, see Div. 12) the brake horse power can be determined separately.

127. The Brake Horse Power Is Computed From Indicator Diagrams, indirectly, whenever it cannot otherwise be found; see Div. 12. Thus, the indicated horse power may be computed from the indicator diagrams directly. Then if the friction horse power is subtracted from the indicated horse power, the brake horse power will result. That is—

(17) *Brake h.p.* =

$$\textit{Indicated h.p.} - \textit{Friction h.p.} \quad (\textit{horse power})$$

NOTE.—MANUFACTURERS OF ENGINES WHICH ARE TESTED BEFORE LEAVING THE FACTORY CAN GIVE THE FRICTION HORSE POWER OF THEIR ENGINES AT DIFFERENT LOADS. This information is often very valuable when tests are to be made or performance guarantees verified.

128. The Weight Of Steam Used By An Engine Can Be Computed from the volume of the cylinder, the number of times it is filled in a certain time and the weight of a unit volume of steam at the pressure at which the cylinder is filled. If steam were a perfect gas (see PRACTICAL HEAT) or a liquid, and if there were no leakage either at the piston or the valves, such a computation would be reasonably accurate. But, since steam is a vapor continually changing in the engine cylinder (some of it) either from the liquid to the vapor or from the vapor to the liquid state, and, since leakage is quite common, the calculated weight of steam used is never equal to the actual, being usually less because the steam is partially condensed inside the cylinder. The calculation is of use,

however, for comparison purposes and as a measure of the ideal minimum amount of steam which could be used by an engine under the conditions.

129. The Weight Of Steam Used By An Engine With No Clearance (Fig. 112) can be found by the following formula, the derivation appearing below:

$$(18) \quad W_{ih} = \frac{13,750 D'_{ps} x_s}{P_m} \quad (\text{lb. per i.h.p.hr.})$$

Wherein: W_{ih} = weight of steam used by one end of an engine, in pounds per indicated horse power hour. D'_{ps} = density of steam at a selected point on the expansion line, in pounds per cubic foot. x_s = fraction of stroke completed (Fig. 112) at that point. P_m = mean effective pressure, in pounds per square inch.

DERIVATION.—The volume of the cylinder is $A_{ip}L_{fs}/144$ cu. ft. (A_{ip} = area of piston in square inches. L_{fs} = length of stroke in feet.) It is filled N (r.p.m.) times per minute or $60 N$ times per hour. The total volume to be filled per hour is then $60 NA_{ip}L_{fs}/144$ cu. ft. If release occurs at d , the end of the stroke, where the pressure is P_a and the density is D_{ps} lb. per cu. ft., the weight of steam used per hour is then $60 NA_{ip}L_{fs}D_{ps}/144$ lb. As the engineer usually wants to know the weight of steam used per indicated horse power per hour (W_{ih}) and as the indicated horse power of the engine is by For. (12) $P_m L_{fs} A_{ip} N / 33,000$, it follows that:

$$(19) \quad W_{ih} = \frac{\text{weight used per hour}}{\text{horse power}} = \frac{60 NA_{ip}L_{fs}D_{ps}/144}{P_m L_{fs} A_{ip} N / 33,000} \\ = \frac{60 NA_{ip}L_{fs}D_{ps} 33,000}{144 P_m L_{fs} A_{ip} N} = \frac{13,750 D_{ps}}{P_m} \quad (\text{lb. per i.h.p. hr.})$$

Since at any other point, b (Fig. 112), after cut-off, the weight of steam within the engine cylinder must be the same as at d , it would be possible to go through the same reasoning for any point and get the same result. The volume filled each stroke would be only a fraction, x_s (Fig. 112) of the total; but the pressure being P'_a , the density would be D'_{ps} . We would get:

$$(20) \quad W_{ih} = \frac{13,750 D'_{ps} x_s}{P_m} \quad (\text{lb. per i.h.p. hr.})$$

which is the same as For. (18).

NOTE.— W_{ih} is computed separately for each end of the cylinder.

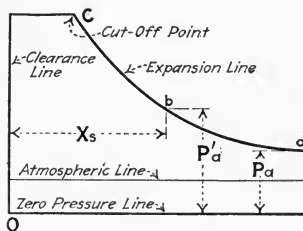

FIG. 112.—Theoretical diagram from an engine with no clearance.

130. The Weight Of Steam Used By Any Simple Engine Can Be Computed From The Indicator Diagrams by the following formula, the derivation of which follows:

$$(21) \quad W_{ih} = \frac{13,750}{P_m} \left[(x_s + x_c) D'_{ps} - (x'_s + x_c) D''_{ps} \right] \quad (\text{lb. per i.h.p. hr.})$$

Wherein: x_c = clearance volume expressed as a fraction of the piston displacement. x'_s = fraction of return stroke uncompleted at a chosen point on the compression curve. D''_{ps} = density of steam at that point in pounds per cubic foot. The other symbols the same as in For. (18).

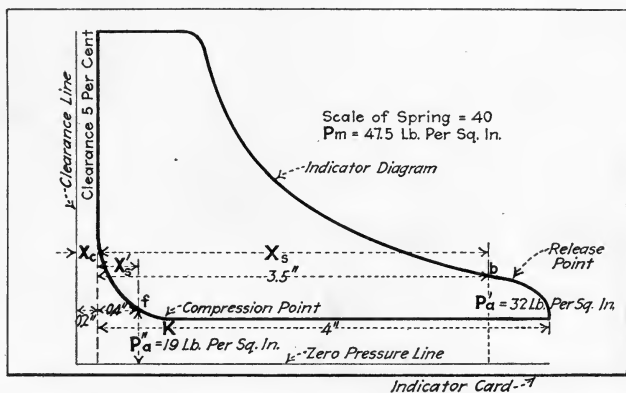

FIG. 113.—Indicator diagram from a simple engine. (Calculation of steam consumption.)

DERIVATION.—Referring to Fig. 113, the diagram being from an engine having a clearance volume of 5 per cent. of the piston displacement, the volume in the cylinder at b is $(x_s + x_c)A_{ip}L_f/144$. Proceeding as in the preceding section the result would be, if this volume were filled every revolution—

$$(22) \quad W'_{ih} = \frac{13,750 D'_{ps}(x_s + x_c)}{P_m} \quad (\text{gross, lb. per i.h.p. hr.})$$

But, since some steam is trapped in the cylinder at k , when the exhaust valve closes, all the steam necessary to fill the volume at b and at a pressure P'_a will not have been admitted every revolution. It is possible likewise to find the *weight not rejected* by taking some point, f , on the compression line and applying to it the same reasoning. The result would be:

$$(23) \quad W''_{ih} = \frac{13,750 D''_{ps}(x_c + x'_s)}{P_m} \quad (\text{unrejected, lb. per i.h.p. hr.})$$

Wherein: x'_s = uncompleted fraction of stroke at f . D''_{ps} = density of

steam at f , in pounds per cubic foot. The net weight of steam required will, of course, be the difference between W'_{ih} and W''_{ih} , which is

$$(24) \quad W_{ih} = W'_{ih} - W''_{ih} = \frac{13,750 D'_{ps}(x_s + x_c)}{P_m} - \frac{13,750 D''_{ps}(x'_s + x_c)}{P_m} \\ = \frac{13,750}{P_m} \left[(x_s + x_c)D'_{ps} - (x'_s + x_c)D''_{ps} \right] \quad (\text{lb. per i.h.p. hr.})$$

which is the same as For. (21).

NOTE.—THE POINTS, b AND f , ARE BEST CHOSEN NEAR THE LOWER ENDS of their respective lines, because there the quality of the steam is apt to be highest (during expansion, the quality increases; during compression, it decreases) and errors due to moisture in the steam will be minimized.

EXAMPLE.—Fig. 113 represents a diagram, showing, with a 40-lb. spring, a mean effective pressure of 47.5 lb. per sq. in. How much steam is accounted for by the diagram? SOLUTION.—The whole length of the diagram is 4 in. $x_s = 3.5$ in./4 in. = 0.875. $x_c = 5$ per cent. = 0.05. $x'_s = 0.4$ in./4 in. = 0.10. $P'_a = 32$ lb. per sq. in. abs: and $P''_a = 19$ lb. per sq. in. abs. From steam tables, $D'_{ps} = 0.077,3$ and $D''_{ps} = 0.047,46$ lb. per cu. ft. Substitution in For. (21) gives,

$$W_{ih} = \frac{13,750}{P_m} \left[(x_s + x_c)D'_{ps} - (x'_s + x_c)D''_{ps} \right] = \frac{13,750}{47.5} \left[(0.087,5 + \right. \\ \left. 0.05)0.077,3 - (0.10 + 0.05)0.047,46 \right] \\ = 289.5[(0.925 \times 0.077,3) - (0.15 \times 0.047,46)] = 289.5(0.071,5 - \\ 0.007,1) \\ = 289.5 \times 0.064,4 = 18.65 \text{ lb. per i.h.p. hr.}$$

131. To Find The Total Steam Used By An Engine Per Hour multiply the weight used per indicated horse power per hour for head and crank end each by the indicated horse power developed by the steam in that end and add together these two products.

EXAMPLE.—An engine shows, at the head end, 40.5 i.h.p. and 20.2 lb. per i.h.p. hr.; at the crank end, 38.8 i.h.p. and 20.6 lb. per i.h.p. hr. What is its total steam rate? SOLUTION.—The head end uses $40.5 \times 20.2 = 818$ lb. per hr. The crank end uses $38.8 \times 20.6 = 799$ lb. per hr. The engine, therefore, uses $818 + 799 = 1617$ lb. per hr.

132. More Specific Uses Of Indicators And Indicator Diagrams As Applied To Compound Engines will be treated in Div. 8.

QUESTIONS ON DIVISION 3

1. What is a steam-engine indicator?
2. What uses can be made of the indicator diagram?
3. What determines whether a pencil mechanism is satisfactory or not?
4. When should an outside spring indicator be used?

5. Why must a reducing motion be used in connection with an indicator?
6. What is a brumbo pulley and where is it used?
7. What is a pantograph?
8. What must be the direction of the drum cord leading from a pantograph?
9. What is the principle of the reducing wheel?
10. What precautions must be taken to avoid distortions of the diagram when using reducing wheels?
11. What are the limitations of the inclined-plane reducing mechanism?
12. What two tests will show up a faulty indicator reducing mechanism?
13. How should a cylinder be piped for indicators?
14. Why must indicator cocks have a relief passage?
15. Why is it better to use two indicators on a cylinder than only one?
16. What is meant by the "number" of an indicator spring?
17. Why must indicator springs be tested?
18. How can indicator springs be tested?
19. What results from using too light an indicator spring?
20. What results from using too heavy an indicator spring?
21. What are the steps in assembling an indicator?
22. What kind of paper should be used on indicators?
23. What sort of pencil should be used in an indicator?
24. What does an atmospheric line show?
25. What are the steps in taking an indicator diagram?
26. What "lines" comprise an indicator diagram?
27. What influences the appearance of the admission line?
28. What causes variations in the steam line?
29. What is a steam-chest diagram and what does it show?
30. What may the expansion line reveal?
31. What form should the expansion line have if an engine is in good order?
32. What do the release and exhaust lines indicate?
33. What defects in an engine may the compression line reveal?
34. On what does the compression pressure depend?
35. How can the mean effective pressure be found without a planimeter?
36. How is the mean effective pressure found with a planimeter?
37. What are averaging planimeters?
38. What are the horse power constants of an engine?
39. What are indicated, brake, and friction horse power?
40. What is the basis of determining steam consumption from indicator cards?
41. Why cannot the weight of steam used by an engine be accurately determined from indicator cards?

PROBLEMS ON DIVISION 3

1. With the pendulum lever mechanism shown in Fig. 114, what length diagram will result? What must be the radius of a brumbo pulley on this lever to give a diagram 3-in. long?

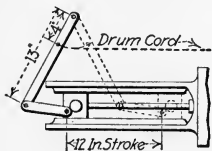

FIG. 114.—(1) What length will the diagram be? (2) What radius for brumbo pulley?

2. What length of indicator diagram will be produced by the reducing-wheel mechanism shown in Fig. 115?
3. By the method of ordinates find the mean height of the diagrams shown in Fig. 116.
4. If the diagrams of Fig. 116 were taken with a 60-lb. spring what are the mean effective pressures shown?
5. The diagrams of Fig. 116 are from an engine having a stroke of 15 in.; a cylinder 12 in. in diam.; and a piston rod $2\frac{1}{2}$ in. in diam. If it runs at 220 r.p.m., what is its horse power?

6. If the clearance at each end of the engine of Prob. 5 is 15 per cent. of the piston displacement, construct the theoretical expansion curves beginning at points *C* and *D*. From points *X* and *Y*, construct the theoretical compression curves.

7. From the results of Prob. 6 can you make any statement as to the conditions of the engine, valves, etc.

8. Find the steam rates for the crank and head ends of above engine using points R, S, X, and Y.

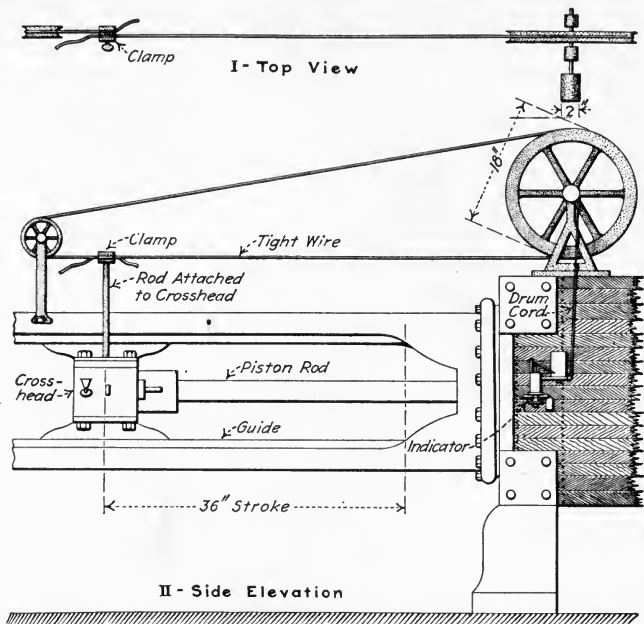

FIG. 115.—What will be the length of the indicator diagram?

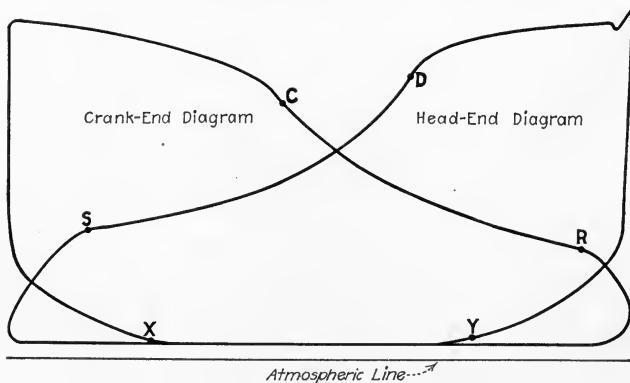

FIG. 116.—Find the mean height of each diagram.

9. Find the total steam used per hour by above engine.

10. Trace off the diagrams of Fig. 116 and measure the areas with a planimeter, and find the mean effective pressures. Compare the results with those of Probs. 3 and 4.

DIVISION 4

SLIDE VALVES AND THEIR SETTING

133. Slide Valves Are Employed In Steam Engines Where Simplicity And Low Price Are More Important than the actual economy of the engine in its use of steam. Slide-valve engines employ but one valve per cylinder and a comparatively simple valve-operating mechanism, whereas engines of greater refinement generally employ a number of valves per cylinder (see Div. 5) and require a more complex mechanism for operating the valves. The scope of this division is to discuss:

(1) *How slide valves function.* (2) *Terms appertaining to slide valves and their operating mechanisms.* (3) *The advantages and disadvantages of slide valves of various types.* (4) *Methods of adjusting slide-valve operating mechanisms.* These adjustments are commonly known as "*valve setting.*"

134. "Valve Diagrams," (Bilgram, Zeuner, Reuleaux) And "The Valve Ellipse" are names given to graphical methods for proportioning engine valves and valve mechanisms. These diagrams are useful chiefly in engine designing, which is beyond the scope of this book. A treatment of these graphical methods is not given herein because they are of little value to the practical operating man. For a discussion of valve diagrams see **VALVE GEARS** by C. H. Fessenden, or **THE DESIGN AND CONSTRUCTION OF HEAT ENGINES** by W. E. Ninde.

135. The Function Of The Slide Valve Is, as explained in Sec. 4, to open and close, at the proper instants, passages through which steam may flow into or out of the engine cylinder. This slide valve, therefore, permits the steam to perform its cycle, Sec. 102, within the engine cylinder. Since a slide valve performs its functions in the same manner for both ends of the engine cylinder, the following explanation, of the method whereby a slide valve controls steam flow into and out

of the head end of a cylinder, is descriptive of its performance for both ends.

EXPLANATION.—In Fig. 117, the valve, *V*, is shown moving to the right and is ready to admit high-pressure steam from the steam chest, *S*, to

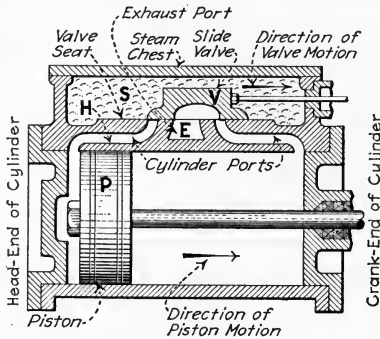

FIG. 117.—Point of head-end admission—steam about to enter the head end of the cylinder.

the head-end cylinder port, *H*, and thence to the head-end of the cylinder. The steam will then force the piston, *P*, toward the right. In the position shown in Fig. 118, *V* has been moved to the right, stopped, and is now moving to the left. It has returned to its former position. Up to this point, high-pressure steam has been admitted to the head-end of the

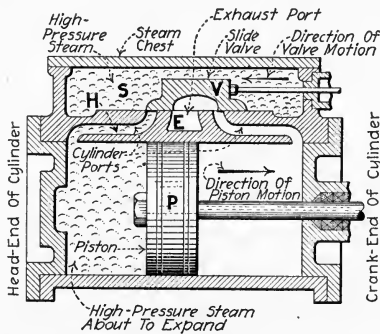

FIG. 118.—Point of head-end cut-off—steam supply from the steam chest has just been cut off from the head end of the cylinder.

cylinder. As *V* moves farther to the left, no more steam will be admitted to *H* because *V* completely shuts it off from *S*. Hence, since the head-end of the cylinder is isolated from the high-pressure steam, the piston continues to move toward the right due only to pressure of the expanding steam in the head-end of the cylinder.

When, as shown in Fig. 119, the piston has almost reached the end of its stroke, traveling toward the right, any further movement of the valve toward the left will allow the expanded steam in the head-end of the cylinder to flow through *H* to the exhaust port, *E*. High-pressure steam is about to be admitted to the crank-end of the cylinder where it will force

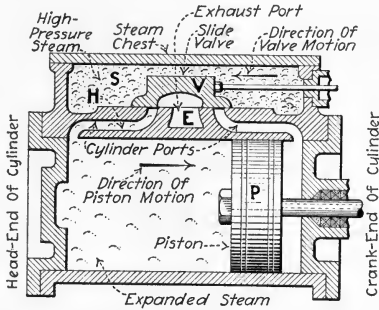

FIG. 119.—Point of head-end release—expanded steam in the head end of the cylinder about to be released or exhausted into the exhaust port.

the piston toward the left. Fig. 120 shows the position of the piston and valve after the expanding steam in the crank-end of the cylinder has forced the piston to the left. The valve has been moved to the left, stopped, and is now moving to the right again. Further movement of the valve toward the right will shut off the head-end of the cylinder from

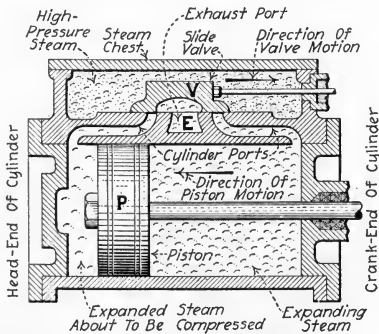

FIG. 120.—Point of head-end compression—the expanded steam remaining in the head end of the cylinder is about to be compressed by the piston.

E, thus confining the remaining steam in the head-end of the cylinder to serve as a “compression” cushion for the piston as it approaches the end of its travel.

NOTE.—THE POINTS OF “ADMISSION,” “CUT-OFF,” “RELEASE,” AND “COMPRESSION” are understood to be the positions of the engine mechan-

ism and the corresponding positions of the indicator pencil on the indicator diagram (Fig. 88) when the valve is in the act of opening or closing the cylinder port. The positions of the slide valve at each of these points are shown in Figs. 117 to 120. Obviously there will be one of each of these points for each end of the cylinder. These are specified as head-end admission, crank-end admission, head-end cut-off, etc.

136. The Terms "Outside-Admission" Or "Direct" And "Inside-Admission" Or "Indirect" As Applied To Slide Valves relate to the manner in which steam is admitted to the cylinder. Thus an "outside-admission" or "direct" valve (Fig. 121) is one which has live, or boiler-pressure steam, *S*, beyond the two ends of the valve and exhaust steam between

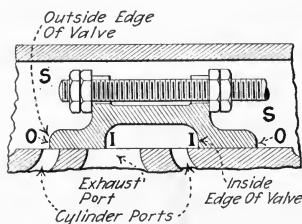

FIG. 121.—An outside-admission slide valve.

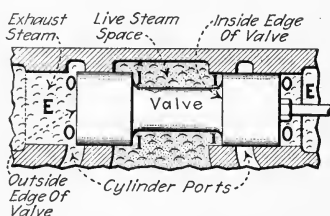

FIG. 122.—An inside-admission slide valve.

the two ends of the valve. Steam enters the cylinder past the outside edges, *O*, of the valve and exhausts from the cylinder past the inside edges, *I*. An "inside-admission" or "indirect" valve (Fig. 122) is one which has exhaust steam, *E*, at the two ends of the valve and live steam between the two ends of the valve. Steam enters the cylinder past the inner edges, *I*, of the valve and exhausts from the cylinder past the outside edges, *O*.

NOTE.—"EXTERNAL," AND "INTERNAL" ARE OTHER TERMS APPLIED TO SLIDE VALVES to denote whether they are of the inside or outside admission type. Outside-admission valves are sometimes called *external*. Also inside-admission valves are sometimes called *internal*. Piston slide valves are practically always designed for inside admission (indirect) whereas other slide valves are nearly always of the outside-admission (direct) type.

137. The Advantages And Disadvantages Of Plain D-Slide Valves may be briefly stated thus: (1) *Advantages*. (a) Con-

struction is very simple. (b) Operating mechanism is simple. (c) Maintenance is low, because of the simplicity. (2) *Disadvantages.* (a) Because of unequal pressures on the two sides, D-slide valves are forced strongly against their seats; this is likely to produce excessive friction and wear at the seat. (b) Cylinder ports are opened and closed slowly; this is the cause of wire-drawing or throttling of the steam, especially at cut-off. (c) Admission, cut-off, release and compression are not independently adjustable. That is, adjustment say of head-end cut-off is likely to affect the adjustment of all events of both ends of the cylinder. (d) Engines with D-slide valves must have comparatively large clearance volumes. (e) Because of unequal temperatures on the two sides of the valves, D-slide valves are apt to warp. This makes them unsuited to engines which operate on superheated steam.

NOTE.—THE DISADVANTAGES OF D-SLIDE VALVES MAY BE PARTIALLY OVERCOME by using slide valves of certain special types which are discussed in the following sections. But no one of these special types eliminates entirely all of the disadvantages. The valve designs discussed in Div. 5 afford the most logical means for overcoming the disadvantages listed above.

138. Advantages And Disadvantages Of Piston Slide Valves :

(1) *Advantages.* (a) Construction is almost as simple as that of the D-slide valve. (b) Operating mechanism is simple. (c) Steam pressure does not produce any unbalanced force on the valve. (d) Temperatures on different parts will not distort the valve; it is therefore suited for superheated steam. (e) Maintenance is low, because of the simplicity. (2) *Disadvantages.* (a) Cylinder ports are opened and closed slowly. (b) Valve events are not independently adjustable. (c) Clearance volume of engine must be very large. (d) Wear of the valve or its seat is apt to cause leakage past the valve and is difficult to take up; frequently wear necessitates replacement of the valve or its seat.

NOTE.—PISTON VALVES ARE USUALLY OF THE INSIDE-ADMISSION TYPE. With inside admission (Fig. 33) the stuffing box on the valve stem seals the opening only against exhaust steam, whereas with outside admission (Fig. 21) the stuffing box holds high-pressure steam. Leaks at the stuffing boxes of inside-admission valves do not, therefore, waste steam because the leaking steam has already been used by the engine. D-slide

valves cannot be of the inside-admission type because high-pressure steam, if within the *D*, would raise the valve off its seat and would thus escape, without doing work, into the exhaust passage.

139. Advantages And Disadvantages Of Balanced Slide Valves (Fig. 123): (1) *Advantages.* (a) Construction is almost as simple as that of the plain D-slide valve. (b) Operating mechanism is simple. (c) Pressure of the steam on the two sides of the valve is nearly balanced; therefore, friction and wear are less than with D-slide valves. (d) Valve is not so badly distorted by temperature differences on its surfaces

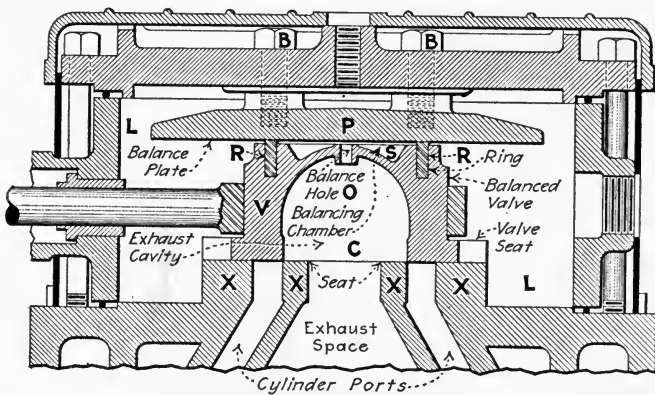

FIG. 123.—A balanced slide valve.

as is a plain D-slide valve. (e) Maintenance is low and compensation for wear is automatic. (2) *Disadvantages.* (a) Cylinder ports are opened and closed slowly. (b) Valve events are not independently adjustable. (c) Clearance volume must be large, though not larger than with the plain D-slide valve. (d) Steam leakage at the valve is likely to be greater than with plain D-slide valves.

EXPLANATION.—Since the exhaust steam enters *S* (Fig. 123) through balance hole, *O*, the downward pressure on *V*, due to the exhaust steam within the area enclosed by ring, *R*, is practically the same as the upward pressure on *V* due to the exhaust steam in the exhaust cavity, *C*. Hence the pressure, due to the exhaust steam, which *V* exerts against *X* is practically zero.

Now, *P* is held rigidly in position by bolts, *B*. Therefore, the live steam in steam space *L* can exert no downward pressure within the area

enclosed by *R*. The only downward pressure which the live steam can exert is that exerted downward on that projected area of *V* which is outside of *R*. This area outside of *R* is, in actual engines, relatively small; in fact it can be made practically zero if the ring, *R*, is arranged around the extreme edge of *V*.

But in actual engines it is desirable that there be some downward thrust of *V* against *X* to hold *V* snugly against its seat to prevent leakage. In actual engines, the projected area of *V* which is outside of *R* is so made by the engine designer that the resultant downward pressure of *V* and *X* is sufficient to effectively prevent this leakage but still not induce excessive friction between *V* and *X*. If some live steam leaks from *L* past *R* into *S*, it passes through *O* to the exhaust. Thus *O* prevents the pressure in *S* becoming greater than the exhaust pressure.

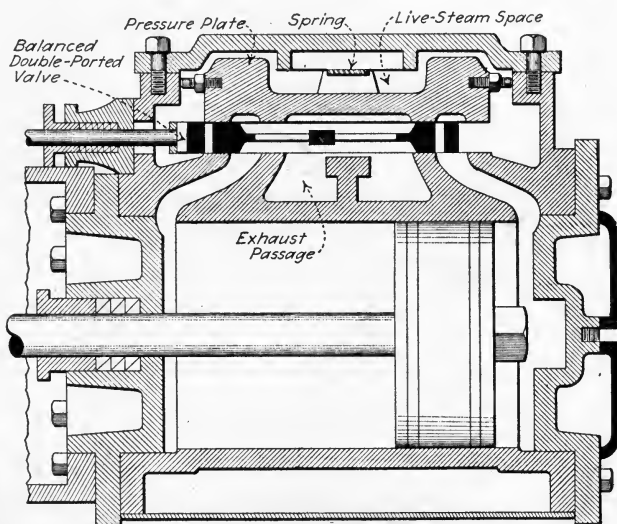

FIG. 124.—Longitudinal section of Sweet valve (Erie Ball Engine Co). This is the same valve as is shown in Fig. 125.

140. Advantages And Disadvantages Of Multiported Slide Valves (Fig. 32, see Sec. 44 for definition) are: (1) *Advantages*. (a) Construction is almost as simple as that of plain D-slide valve. (b) Operating mechanism is simple. (c) Cylinder ports are opened and closed more quickly than with the valves already discussed. (d) Valve travel need not be so great as with single-ported valves; this means that less power will be required to slide the valve on its seat. (2) *Disadvan-*

tages. (a) Unless the valve is balanced, see note following, the steam pressure is likely to cause excessive friction and wear at the seat and also to cause distortion of the valve. (b) Valve events are not independently adjustable. (c) Clearance volume must be large.

NOTE.—BALANCED MULTI-PORTED VALVES COMBINE THE FEATURES OF THE BALANCED AND THE MULTI-PORTED slide valves. Figs. 124 and 125 show a modern form of balanced multi-ported valve. It is to be noted that in this valve the auxiliary ports affect only the admission of high-pressure steam to the cylinder. The exhaust steam passes through only a single valve-port. Some balanced multiported valves also exhaust through an auxiliary port.

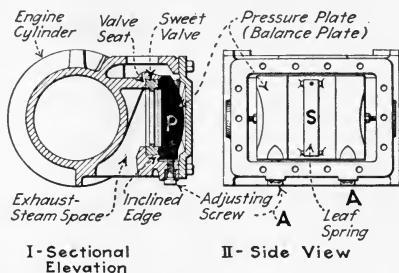
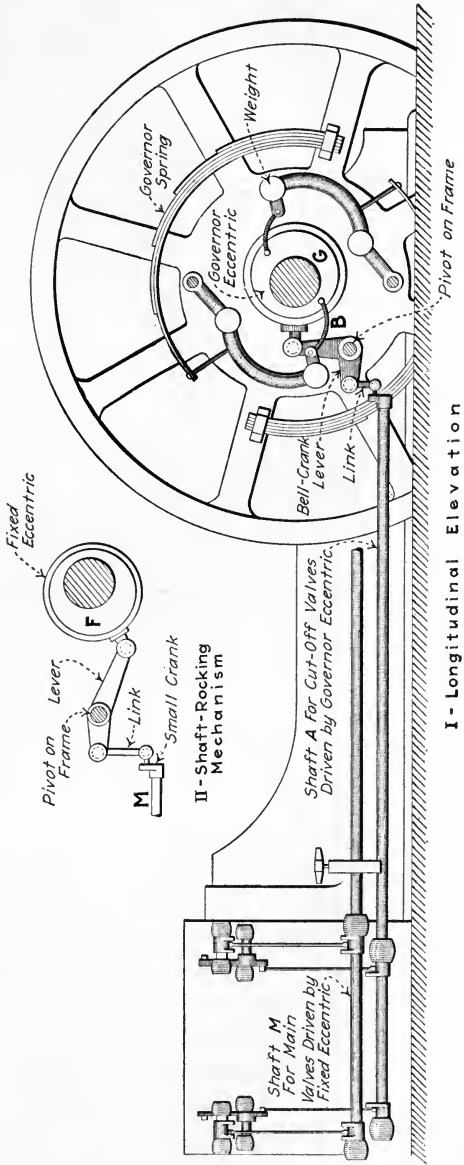

FIG. 125.—Transverse section and side view of Sweet valve.

141. Advantages And Disadvantages Of Riding-Cut-Off Slide Valves (Fig. 34): (1) *Advantages.* (a) Cut-off is effected rapidly; that is, cut-off takes place when the riding blocks are near their mid-travel position and travelling relatively fast. (b) Cut-off can be effected at the same fraction of both the forward and the return stroke; thus, the work done in the two ends of the cylinder can be equalized. (c) The construction of the cylinder, valves, and their operating mechanism is simpler than with other engines which have advantages (a) and (b). (2) *Disadvantages.* (a) Except when made in piston form—as in the Buckeye engine—the valve is unbalanced and presents two surfaces along which excessive friction may act; hence much power is required to move the valves and wear may be excessive. (b) Engine clearance is large. (c) The valve-operating mechanism consists of twice as many parts as does that for a simple slide valve; hence, the riding-cut-off valve is apt to give more trouble and require more attention.

142. Features Of The Gridiron-Valve Engine (Figs. 126 to 128) are that: (1) *The valves require small movement* (from $1\frac{1}{2}$ in. to $1\frac{1}{2}$ in.). (2) *Having four valves and two eccentrics, all events of both ends of the cylinder are independently adjustable.*



I - Longitudinal Elevation

Fig. 126.—Side view of McIntosh & Seymour engine showing complete valve-operating mechanism.

(3) *Clearance is very small* (usually less than with Corliss valves). (4) *The valve-operating mechanism permits of high engine speeds.* (5) *Cut-off occurs quickly*, while the valves are moving fast, and it is the only event that need be changed during governing. Its chief disadvantages are that the valve-operating mechanism is relatively complex, the construction of the engine makes it costly, and adjustment of the valve-mechanism is relatively difficult.

EXPLANATION.—In the McIntosh Seymour Engine (Figs. 126 to 128) each cylinder has four main valves—two steam and two exhaust—and

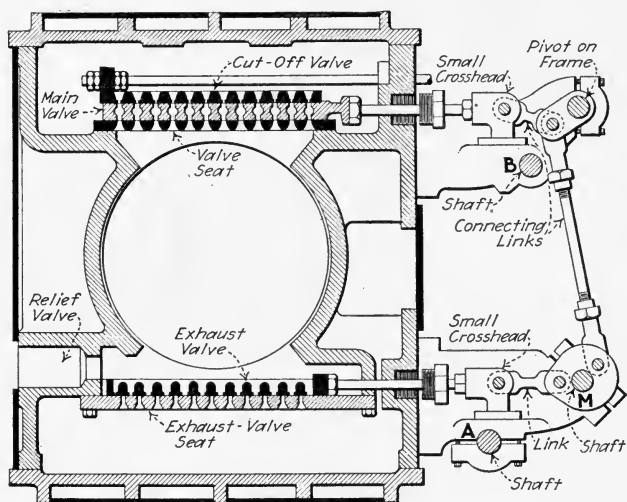

FIG. 127.—Section through head of McIntosh & Seymour engine showing main-valve operating-mechanism.

two auxiliary or riding-cut-off valves, all of which are of gridiron construction. The four main valves are driven from a main rock shaft, *M*, (Fig. 127) which is rocked by the mechanism of Fig. 126 from a fixed eccentric, *F*, on the crank shaft. The main valves control the points of admission, release, and compression which can be adjusted independently for each end of the cylinder. The auxiliary or riding cut-off valves are driven from another rock shaft, *A*, (Fig. 128) which is operated from a governor-controlled eccentric, *G*, as shown in Fig. 126. The motions derived from the eccentrics are so distorted by the several links that the valves move quickly in opening, pause when full open, and remain almost stationary when closed.

NOTE.—THE SETTING OF GRIDIRON VALVES is rather complex and will not be discussed in this book for lack of space. The reader is, therefore, referred to the manufacturer for instructions for setting gridiron valves.

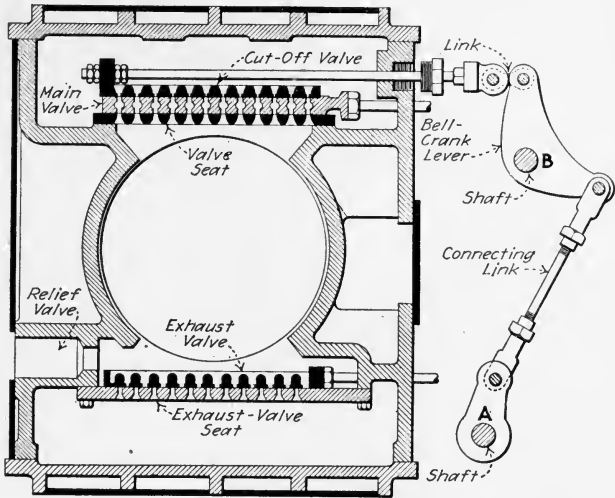

FIG. 128.—Section through head of McIntosh & Seymour engine showing cut-off-valve operating-mechanism.

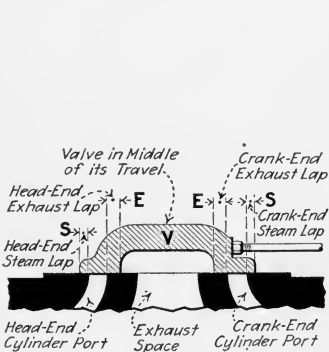

FIG. 129.—Outside-admission (D-slide) valve showing lap.

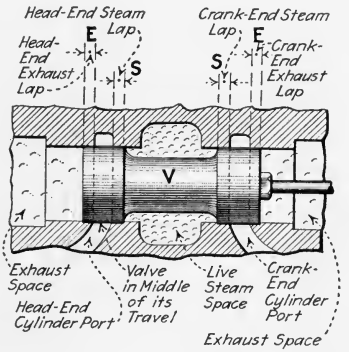

FIG. 130.—Inside-admission (piston) valve showing lap.

143. Valve "Lap" is (Figs. 129 and 130) the amount (length) by which a valve overlaps or extends beyond the cylinder port when the valve is mid-way between its extreme

positions. As a slide valve has four edges with which it cuts off steam flow, there will be valve lap measured to each of these edges. Various terms which are used to designate the lap at the different points are defined graphically in the following illustrations: *exhaust lap* and *steam lap*, Figs. 129 and 130; *inside lap* and *outside lap*, Figs. 131 and 132.

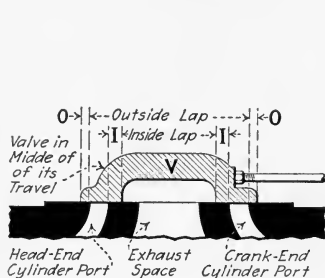

FIG. 131.—Illustrating inside and outside lap of an outside-admission (D-slide) valve.

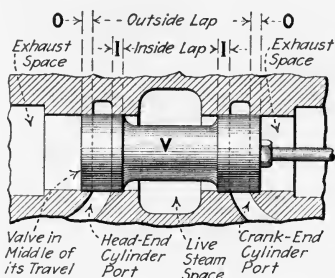

FIG. 132.—Illustrating inside and outside lap of an inside-admission (piston) slide valve.

NOTE.—INSIDE CLEARANCE OF A SLIDE VALVE (Fig. 133) is the amount (length) of opening, N , of the cylinder ports to the exhaust passage, E , when the valve, V , is mid-way between its extreme positions. It is the exact opposite of inside lap and is sometimes called *negative lap*. Inside clearance permits of very early release and late compression.

144. The Purposes Of Steam And Exhaust Lap Are :

(1) *Steam lap enables a valve to cut off the high-pressure steam supply to the cylinder before the piston reaches the end of the stroke.* In other words it permits the use of steam expansively, Sec. 15. (2) *Exhaust lap delays release and brings about earlier compression in engines where the valves have sufficient steam lap to effect a desirable cut-off.* Increased steam lap necessitates greater valve movement which in turn provides a longer exhaust period. In engines with valves which have plenty of steam lap but no exhaust lap, the working steam in the cylinder would be released too early, thus preventing the proper steam expansion.

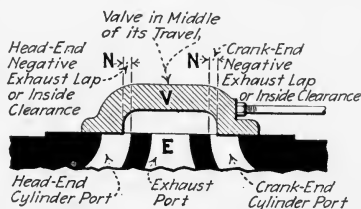

FIG. 133.—A slide valve with negative exhaust lap or "inside clearance."

145. To Change The Lap Of A Slide Valve it is necessary to either cut away part of the valve or add to the valve. As it is usually very expensive to add to the valve, a new valve would usually be procured whenever this is necessary. Engine valves should always be furnished by their manufacturers with the proper lap to suit the operating conditions. Therefore, it is seldom necessary to change the lap of a valve except when the engine is to be used under steam pressures different from those for which it was designed. If, however, it does become necessary to change the valve dimensions, the best procedure is to have the engine builder furnish a new valve to suit the new conditions. If the manufacturer cannot be reached and if it is firmly established that the valve lap must be changed, then the changes may be made in accordance with Table 146.

146. Table Showing Effects Of Changing Valve Lap.—The lap should always be changed by equal amounts on both the head-end and the crank-end cutting edges.

Lap change		Effect on point of			
		Admission	Cut-off	Release	Com- pression
Steam lap.....	Increased Decreased	Later Earlier	Earlier Later	Unchanged Unchanged	Unchanged Unchanged
Exhaust lap.....	Increased Decreased	Unchanged Unchanged	Unchanged Unchanged	Later Earlier	Earlier Later

147. "Lead" Is Understood To Mean the amount (length, Fig. 134) by which a valve, *V*, opens a cylinder port for the admission of supply steam when the piston is exactly at the end of its stroke within the engine cylinder. Unlike lap, lead is not determined by the dimensions of the valve. Lead is determined wholly by the adjustment of the valve mechanism. The purpose of so adjusting the valve that it provides lead is to insure that steam will enter the cylinder shortly before the piston reaches the end of a stroke. The objects of thus admitting the steam are: (1) *To have it aid, by its compression, in bringing the piston to rest before its reversal in direction of*

motion. (2) To insure full steam-supply pressure behind the piston as it begins its next stroke.

EXPLANATION.—It requires a short time interval for sufficient steam to enter the cylinder to completely fill the clearance volume to supply pressure. If steam were first admitted to the port, just as the piston reached the end of its stroke, the momentum of the flywheel would cause

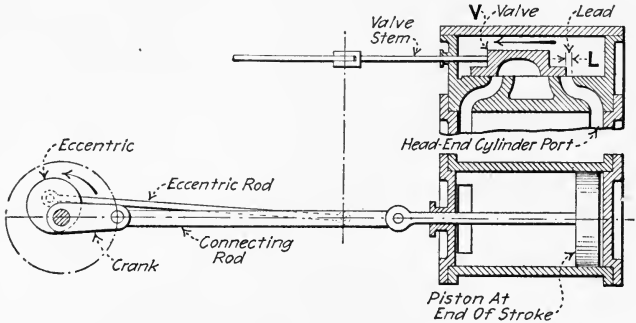

FIG. 134.—Engine on head-end dead center showing head-end lead.

the piston to recede from the cylinder end before enough steam were admitted to fill the clearance volume. If, however, the cylinder port is opened shortly before the piston reaches the end of the stroke, the pressure within the clearance volume will rise to supply pressure before the piston leaves the end. Thus lead, or earlier opening, adds to the pressure behind the piston during the first part of the stroke, and therefore adds to the work done by the steam on the piston (Div. 1).

148. The Slide Valve Usually Receives Its Motion From An Eccentric (E, Fig. 135) which is attached to the engine shaft,

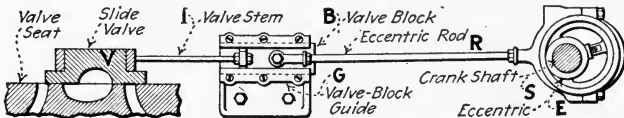

FIG. 135.—Eccentric mechanism.

S. The valve, V, and valve block, B, are fastened to opposite ends of the valve stem, I. B serves the same purpose as does the crosshead in the standard engine crank-mechanism. The eccentric rod, R, is fastened at one end to B and at the other end to the eccentric, E. Thus the motion of the eccentric is transmitted through R, B, and I to the valve V.

NOTE.—THE ECCENTRICITY OR THROW OF AN ECCENTRIC (Fig. 136) is the distance, R , between the center of the crank shaft and the center of the eccentric itself. It can be considered as the distance the eccentric is “off-center” from the crank shaft. The circle of radius R (Fig. 136) is called the *eccentric circle*.

149. The Motion Derived From An Eccentric is equivalent to that from a crank whose radius is equal to the throw of the eccentric. That this is true is demonstrated below.

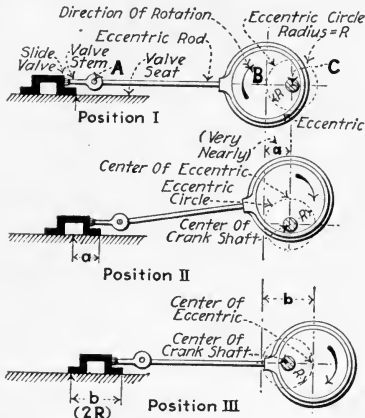

FIG. 136.—Illustrating valve travel with eccentric motion.

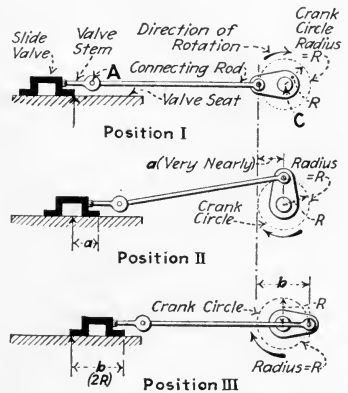

FIG. 137.—Showing valve operated by a crank on the shaft.

EXPLANATION.—In Fig. 136, an eccentric attached to a slide valve is shown in three successive positions. The eccentricity is represented by the distance, R . As the eccentric moves from Position I to Position II, the valve moves the distance a . Likewise, as the eccentric moves from position I to Position III, the valve moves the distance b . In Fig. 137 the same valve is shown attached by a connecting rod to a crank. This crank has a crank-arm length, BC , or distance from the center of the crank pin to the center of the crank shaft which is represented by R . The distance, R , in Fig. 137 is the same as the throw, R , of the eccentric in Fig. 136. As the crank in Fig. 137 moves from Position I to Position II, the valve moves the distance a . As the crank moves from Position I to Position III, the valve moves the distance b . Measurement will show that the distances a and b in Fig. 136 are the same as the distances a and b in Fig. 137. Hence, an eccentric motion is equivalent to a crank motion and an eccentric can be considered as a developed form of the crank with the crank pin sufficiently enlarged to encircle the crank shaft.

150. Valve “Travel” Can Be Defined (Fig. 136) as the distance between its extreme positions or the distance the valve

when the piston is at the end of its stroke. To insure proper operation, the eccentric must, as will be shown, be shifted forward through a sufficient angle to allow steam to enter the cylinder.

In Fig. 139 the crank, C , is shown in its original position but the eccentric has been shifted forward through a sufficient angle to move V forward a distance equal to its steam lap. The center line of the eccentric in the new position is DF . The angle, AMD , through which it was

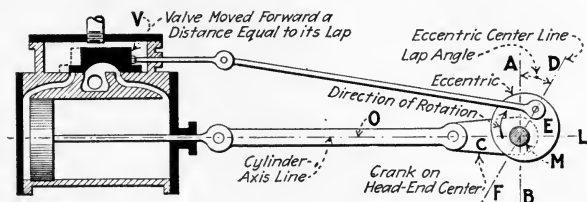

FIG. 139.—Valve moved forward a distance equal to its lap with crank on head-end center. The lap angle is shown here. (Lead angle = 0).

necessary to shift the eccentric to move the valve, V , a distance equal to its lap is called the *lap angle*. But this setting of the valve provides no lead, (Sec. 147).

Now since, to insure satisfactory operation, all engines must have a definite amount of lead (Sec. 147) the eccentric must again, to provide this lead, be shifted ahead from the position shown in Fig. 139 to that shown in Fig. 140. The additional angle, DMH , through which the eccentric has been shifted from position, DF (Fig. 139) to obtain the lead

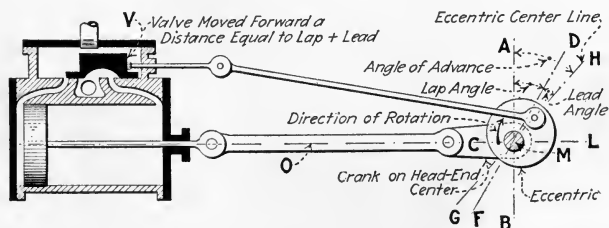

FIG. 140.—Valve moved forward a distance equal to the sum of its lap and lead with crank on head-end center. Lap angle, lead angle, and angle of advance are shown.

is called the *Lead Angle*. The *Angle Of Advance*, AMH , as defined above is therefore the angle between the eccentric positions AB and GH and is equal to the sum of the lap angle and the lead angle as shown in Fig. 140.

NOTE.—WITH INSIDE-ADMISSION VALVES THE ANGLE OF ADVANCE (Fig. 141) is determined by the same rule (above). It is to be observed, however, that with inside-admission valves the eccentric lags behind the

crank by the angle $OMH = 90 \text{ deg.}$ —angle of advance—whereas, with outside-admission valves the eccentric leads the crank by the angle OMH (Fig. 140) $= 90 \text{ deg.} + \text{angle of advance.}$

NOTE.—THE “DISPLACEMENT” OF A SLIDE VALVE is the distance that the valve has, at any instant, been moved from its central position. Thus, when an engine is on dead center: *displacement of the valve = the steam lap + the lead.*

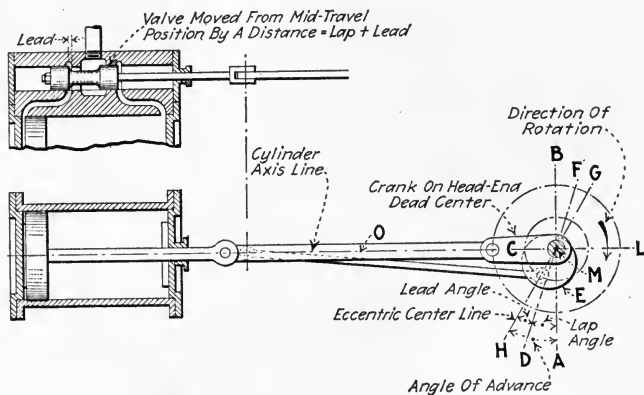

FIG. 141.—Showing angle of advance for an inside-admission (piston) slide valve.

152. The “Angularity” Or “Obliquity” Of A Connecting Rod is its ever-changing angular position with respect to the engine-cylinder axis line. At the instant pictured in Fig. 142, it is the angle FBD . When the crosshead is at the end of its stroke (Fig. 143, *I*) the angularity is zero. The effects of connecting-rod angularity are: (1) *It makes the average velocity of the crosshead during the first half of its stroke, on the forward stroke (toward the shaft), greater than that during the second half of its stroke.* (2) *On the return stroke, angularity makes the average velocity of the crosshead during the first half stroke less than that during the second half.* Since the motion of a slide valve is not appreciably affected by the angularity of its connecting (eccentric) rod,¹ the unlike speeds of the crosshead during the forward and return strokes will tend to make unequal the valve events for the two ends of the cylinder. Thus, if any one event, such as cut-off, were made to occur at the same fraction of both the forward and return strokes, all other events would occur at unequal fractions of the two strokes.

¹NOTE.—THE ANGLE, AT ANY INSTANT, BETWEEN THE ECCENTRIC ROD AND THE VALVE-STEM AXIS LINE WOULD BE CALLED THE ANGULARITY OF THE ECCENTRIC ROD. NOW, SINCE THE ECCENTRIC ROD IS ORDINARILY OF GREAT LENGTH AS COMPARED TO THE THROW OF THE ECCENTRIC, THE ANGULARITY OF THE ECCENTRIC ROD NEVER BECOMES VERY LARGE. FOR SMALL ANGULARITIES THE EFFECTS EXPLAINED ABOVE ARE SO SMALL THAT THEY MAY PRACTICALLY BE NEGLECTED.

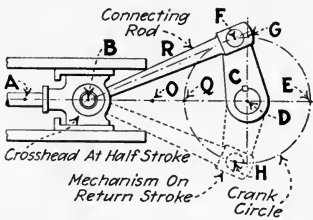

FIG. 142.—Showing position of crank when crosshead is at half stroke.

from *F* to *E*. Thus, since the rotating speed of the crank pin of a constant-speed engine does not vary, the average piston speed must be greater from *A* to *B* than from *B* to *O*. The reason is that half of the stroke, *AO*, has been completed before the crank pin has turned a quarter of a revolution; that is, before the crank pin has reached *G*. Likewise, on the return stroke (mechanism is shown dotted on return stroke) the crank pin turns from *E* to *H*, or more than a quarter revolution, while

EXPLANATION.—Fig. 142 is a diagram of a crank-and-connecting-rod mechanism of a constant-speed engine. The crosshead, *B*, is shown in the middle of the stroke, *AO*, under which condition the crank pin is at *F*. It is evident that, as the crosshead completes the first half of its forward stroke, the crank pin moves from *Q* to *F*. Also, as the crosshead completes the last half of its stroke, the crank pin moves

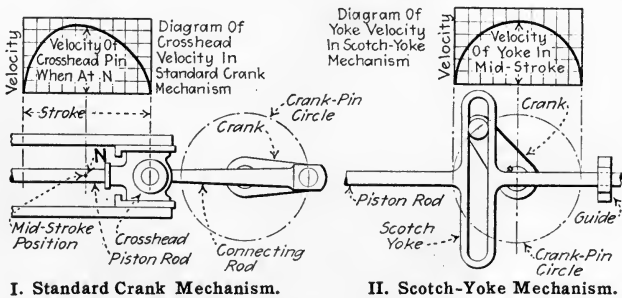

FIG. 143.—Velocity diagrams for standard crank and scotch-yoke mechanisms.

the crosshead completes the first half of its return stroke, or *O* to *B*. Furthermore, the crank pin turns from *H* to *Q* while the crosshead completes the last half of its return stroke, or *B* to *A*. Hence, on the return stroke, the average speed of the piston from *O* to *B* is less than its average speed from *B* to *A*. Hence, it is evident that even though the circumferential speed of an engine crank pin is constant, the average speed of its crosshead will, because of angularity, be greater during the first half of its stroke than during the last half—or vice versa.

NOTE.—THE VARIATIONS OF THE CROSSHEAD VELOCITY DURING A STROKE may be shown by plotting the velocity on a graph (Fig. 143, I). It is evident from this graph that the crosshead velocity during the head-end part of the stroke is greater than that at corresponding points in the crank-end part of the stroke. The *Scotch-yoke mechanism* (Fig. 143, II) gives a velocity diagram which does not show such characteristics. This is because there is no angularity with this mechanism.

153. "Dead Center" denotes the position of an engine mechanism (Figs. 144 and 145) when the piston is exactly

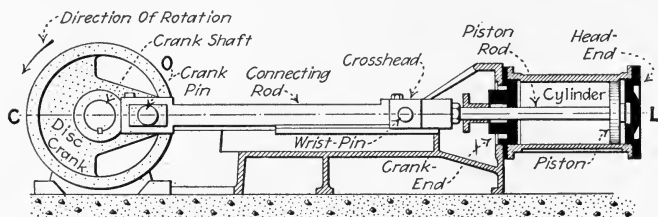

FIG. 144.—Engine on head-end dead center.

at one end of its stroke. An engine is evidently on dead center when the center, *O*, of its crank pin lies on the cylinder axis, *CL*. The two dead-center positions are termed: (1) *Head-end dead center*, when the piston, *P*, is at the extreme end of its stroke and nearest to the cylinder head. (2) *Crank-end dead center*, when the piston, *P*, is nearest to the engine crank

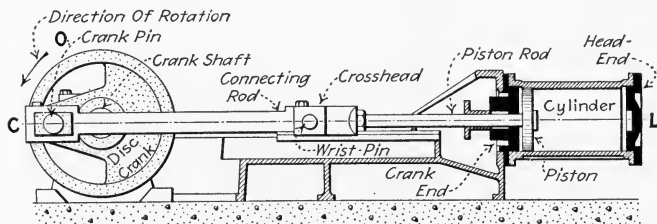

FIG. 145.—Engine on crank-end dead center.

shaft and at the extreme end of its stroke. In making valve adjustments, it is essential that one understands how to place the engine exactly on dead center. A slight error in the position of the crank shaft when the engine is thought to be on dead center will introduce a relatively large error in the position of the valve, even though the piston may appear to be at the end of its stroke.

NOTE.—TO PLACE AN ENGINE ACCURATELY ON DEAD CENTER BY THE TRAMMEL METHOD (Fig. 146) the engine is turned by hand (or by “barring”) in the same direction as that in which it normally runs until the crosshead is somewhere near the end of its stroke. Then a mark, A,

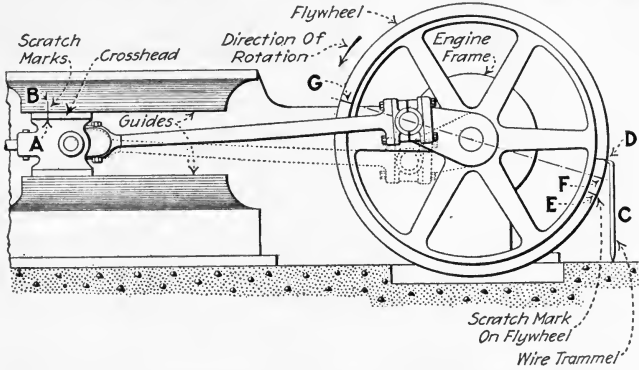

FIG. 146.—Illustrating method of finding the dead centers of an engine.

is scratched on the crosshead and a mark, B, directly opposite A, is scratched on one of the guides. Then, with the engine remaining in this position, a pointed tram, C, (Figs. 146 and 147) is placed in a center-punch mark on the floor or engine frame and a mark, D, Fig. 146, is scratched with the upper end of the trammel on the engine flywheel, as shown. The trammel may be of any reasonable size but usually it can be worked with most conveniently if its upper end extends about 3 ft. or less above the floor line.

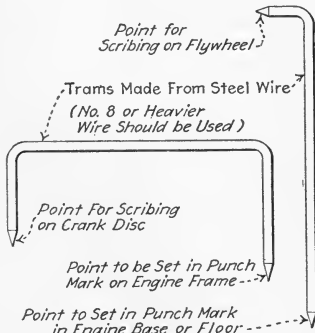

FIG. 147.—“Trams” used in placing engines on dead center.

The engine is now turned past the dead center, in the same direction, until point, A, returns and again coincides with B. Then the mark E is scratched on the flywheel with the trammel. The distance DE is then bisected (halved) with a pair of dividers and a mark, as at F, is scratched at the bisection. The engine is now turned until the point F, coincides with the upper trammel point. The engine is then on one of the dead centers (head-end dead center in Fig. 146). The other—crank-end—

dead center is diametrically opposite the one just located at F. To mark the other dead-center point on the flywheel, measure the circumference around the face of the wheel with a steel tape. Take half the circumference and scratch a mark, as G, at the corresponding point.

If the running direction is the reverse of that indicated by the arrow, locate point *E* before locating *D*. In any case when setting the engine on center, after locating the middle point *F* on the wheel, turn the wheel backward through about $\frac{1}{4}$ turn before finally bringing the middle mark *F* up to the trammel point.

NOTE.—A METHOD OF PLACING AN ENGINE ON DEAD CENTER BY USING A STATIONARY MARKER INSTEAD OF A TRAMMEL IS SHOWN IN

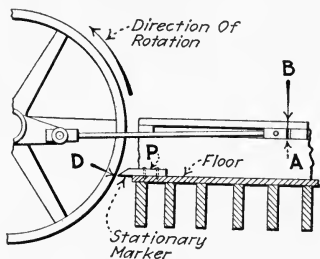

FIG. 148.—First position. The marker, *P*, should be rigidly fixed. Marker location scribed on flywheel at *D*.

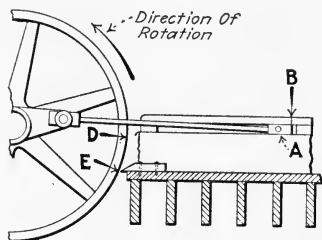

FIG. 149.—Second position. Marker location again scribed on flywheel at *E*.

Figs. 148, 149 and 150. This method may be more convenient where the marker, *P*, can be fastened rigidly to some stationary object which is adjacent to the flywheel rim. The general procedure with this is the same as with the trammel method which is described above. The reference letters used in the trammel-method description also apply to Figs. 148 to 150.

NOTE.—A CONVENIENT METHOD FOR SETTING A VERTICAL ENGINE ON DEAD CENTER (Troy Engine Co.) is illustrated in Fig. 151. Turn the engine to near dead center.

Mark some point, *P*, on the frame with a center punch. With a tram (which may be a wooden stick having a nail driven through each of its ends) and with *P* as a center, scribe point *S* on the rim of the wheel. Spot another center-punch mark, *A*, on the frame. With a pair of dividers, or another tram, and with *A* as a center, scribe arc *B* on the crosshead. All of the foregoing are shown in *I*.

Now, turn the engine through dead center and until the crosshead returns to its former position (see *II*), the distance *AB* being the same as in *I*. Then again with *P* as a center and with the first-used tram, scribe a second mark *T* on the rim of the wheel. With dividers locate the point, *C*, which is midway between *S* and *T*. Turn the wheel until the tram just reaches from *P* to *C*, as in *III*. The engine will then be on dead center.

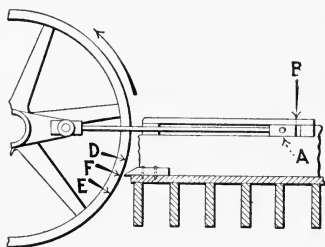

FIG. 150.—Third position. Engine on dead center; mark, *F*, opposite marker.

CAUTION.—WHEN SETTING VALVES, THE FLYWHEEL MUST ALWAYS BE TURNED IN THE SAME DIRECTION to any desired position. By so doing, compensation for looseness in bearings is automatically afforded. Thus, if the flywheel is accidentally turned beyond some desired position, it must first be turned back beyond that position and then reversed and

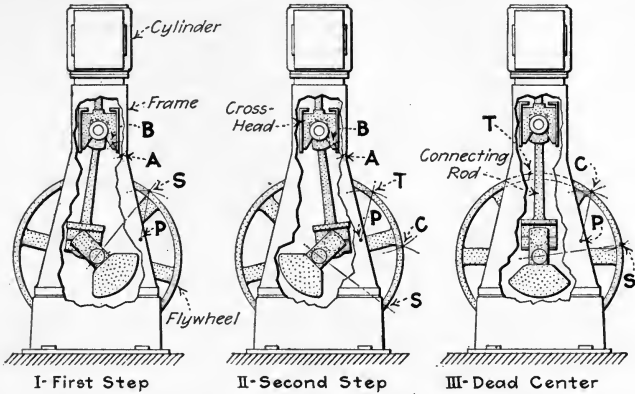

FIG. 151.—“Troy” method of setting an engine on dead center.

again be turned forward to the required position. If this is not done, there is no assurance that the crosshead and piston occupy the proper positions with respect to the crank.

154. An Accurate And Convenient Method Of Setting An Eccentric “On Center” (Figs. 152 and 153) in order to find the

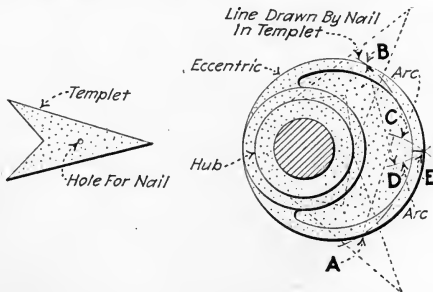

FIG. 152.—Application of templet in finding the dead centers of an eccentric.

two extreme positions of the valve upon its seat, involves the use of: (1) *A templet* as shown in Fig. 152 to make a mark on the eccentric. (2) *A trammel* as shown in Fig. 153 to make marks on the eccentric strap.

EXPLANATION.—Place the templet on the eccentric hub (if hub is not machined, use the templet directly on the shaft) as shown dotted in Fig. 152 and slide it around the hub until a nail inserted through the hole in the templet comes in contact with the edge of the eccentric, as at *A* and *B*. Then, using a pair of dividers adjusted by trial to the proper radius, describe the *arc, C*, with point *A* as a center, and the *arc, D*, with point *B* as a center so that the arcs meet on the edge of the eccentric at *E*. This point, *E*, is then the point of the eccentric farthest from the shaft center.

To find corresponding reference marks on the eccentric strap (Fig. 153) a center-punch mark, *H*, is made at any convenient point on the center line of the valve stem as shown. Holding one end of the trammel in *H*, the arcs *S* and *T* are scribed with the other end. *Arc S* and *arc T* intersect the eccentric edge at points *U* and *V* respectively. Now, using points *U* and *V* as centers, arcs *P* and *Q* are drawn with a pair of dividers

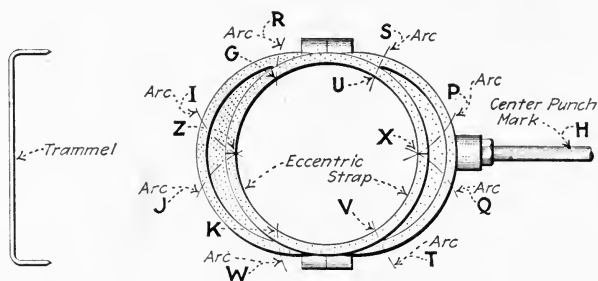

FIG. 153.—Application of trammel in finding the dead centers of an eccentric strap.

adjusted to the proper radius so that *P* and *Q* intersect at the eccentric edge at *X*. Then *X* is one required reference mark on the eccentric strap. To find the other reference mark of the eccentric strap, the arcs *R* and *W* are scribed from points *U* and *V* or from *H*. Then from the points *G* and *K* where *R* and *W* strike the eccentric edge, arcs *I* and *J* are so scribed—as were *P* and *Q*—that, they intersect at the eccentric edge at point *Z*, which is the second reference mark on the eccentric strap.

The eccentric is in the “on-center” position (the valve in its extreme position) when point *E* (Fig. 152) coincides with either point *X* or *Z* (Fig. 153). The point *E* should be marked on the eccentric—and the points *X* and *Z* should, after they have been located, be marked on the eccentric strap—with a cold chisel. This will facilitate future adjustments of the valve and eccentric.

155. The Setting Of Steam-Engine Valves or the adjusting of the valve-operating mechanism can be accomplished in two ways:

(1) *By observing the operation of the valve when the cover is*

removed from its chest and as the engine is turned by applying external force to the flywheel. This method of setting valves is frequently called *setting by measurement*. Sometimes it is possible to watch the movement of the valve past the port edges and, in the proper positions, to measure the length of the port opening; such valves may be set by *direct measurement*. With certain other engines these openings must be measured indirectly (Sec. 156) or by making templates or working models of the valve and its seat; *indirect measurement setting* is necessary for these engines. Setting by measurement, because of the many influencing factors in steam engine operation, is not subject to rigid rules and, therefore, is not sure to produce the best results in every case. It is, on the other hand, a relatively rapid and reasonably-certain method for setting slide valves. This method is discussed in following sections.

(2) *By studying steam engine indicator diagrams* taken from the engine and making changes which seem, after this study, to be necessary. This method requires a thorough understanding of the relations between the valve mechanism and the indicator diagram, which is treated fully in Div. 3. This

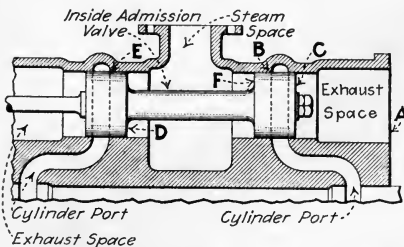

FIG. 154.—Illustrating method of setting an inside-admission valve where the cylinder ports are not accessible.

method is likely to be slow and cumbersome at first trial. But, after some experience, one learns to set the valves quite rapidly. It is the only method, however, which insures certainty of valve adjustment. It should, therefore, be used to check the final setting of all valves even when a preliminary setting has been made by measurement.

156. The "Indirect-Measurement" Method of Ascertaining Valve Operation must be employed whenever the valve ports are not accessible for direct observation. As piston valves are generally of the inside-admission type, they are the ones to which this method is most often applied.

The method is explained below. See also the example under Sec. 167 wherein the setting of a piston slide valve by an indirect method is described.

EXPLANATION.—After the valve-chest cover is removed some line, such as *A*, Fig. 154, is selected as a reference point, from which measurements are to be taken. The line, *A*, must be so chosen that it will not be covered by the valve at any time during its motion. The distances, *AB* and *AE*, are then measured accurately with a steel scale while the valve is removed from the chest. Also the lengths of the valve from *C* to *F* and from *C* to *D* are measured. The valve may then be replaced into the seat. The edges *F* and *B* of the valve and seat may then be placed to coincide by moving the valve until the distance from *A* to *C* or $AC = AB - CF$. Likewise the edges *D* and *E* will coincide when $AC = AE - CD$. The exact opening of the cylinder port at any time can also be determined by similar measurement to the face, *C*, of the valve.

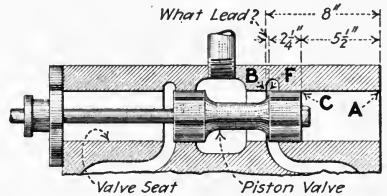

FIG. 155.—Finding lead by indirect measurement.

EXAMPLE.—If (Fig. 155) $AB = 8$ in., $CF = 2\frac{1}{4}$ in., and when the engine is on dead center AC measures $5\frac{1}{2}$ in., what is the lead? **SOLUTION.**—Obviously, the lead = $8 - (5\frac{1}{2} + 2\frac{1}{4}) = 8 - 7\frac{3}{4} = \frac{1}{4}$ in.

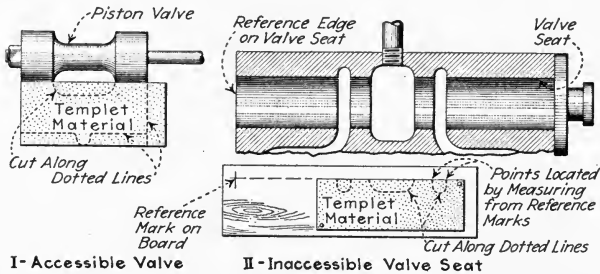

FIG. 156.—Showing methods of making templets of valves and seats. (Whenever the templet material can be placed against the valve or seat, use the method at the left. Templets of inaccessible seats are made as shown at the right.)

157. The Templet Method Of Ascertaining Valve Operation is a modification of the indirect-measurement method. Templets (Fig. 156), or full-size working models, of the valve and its seat are cut from thin material such as sheet metal, cardboard, or thin wood. Templets of inaccessible valve seats must be made from measurements. Templets of valves and

accessible seats may be made by placing the templet material with its edge against the valve or seat (Fig. 156, I), and marking the working edges directly from the valve or seat. After the templets are made, the valve may be replaced in its chest and set into its midtravel position (Fig. 157) either by direct

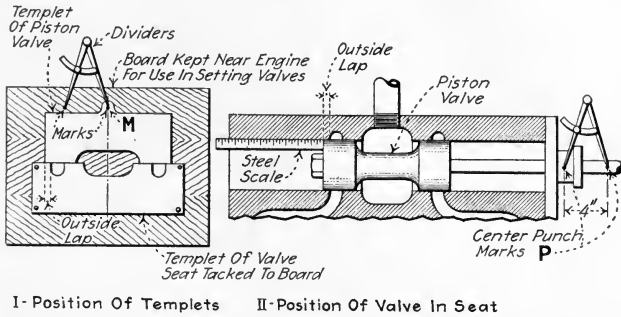

FIG. 157.—Method of establishing marks for setting a slide valve with templets.

observation or by indirect measurement. In this position the laps at the two ends of the valve should be equal. The valve-seat templet is then tacked to a board and the valve templet placed against it (Fig. 157, I) in the same relative position as the valve in the seat. Punch marks, P, are then

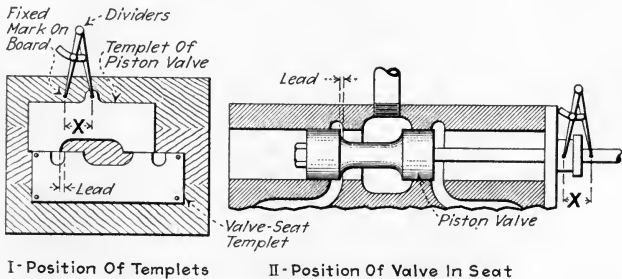

FIG. 158.—Method of determining lead when setting a slide valve by means of templets.

made on the valve chest and the valve rod a convenient distance apart (4 in. in Fig. 157, II). Similar marks, M, are made, as shown, on the valve templet and on the board. Once these templets have been made and marked, future

valve adjustments can be effected without removing the valve chest cover. Likewise (Fig. 158), the position of the valve upon its seat can be determined at any instant—as, for instance, during adjustment—simply by making equal the distances, X , between the two pairs of marks. See also the example under Sec. 167 which describes how wooden battens may be used instead of templates.

158. Adjustment Of A Slide-Valve Mechanism Can Be Effected In Only Two Ways: (1) *By changing the position of the eccentric on the crank shaft, thus changing the angular advance of the eccentric.* (2) *By changing the position of the valve upon its seat for any eccentric position.* This is done by altering the total length from the eccentric center to the valve,

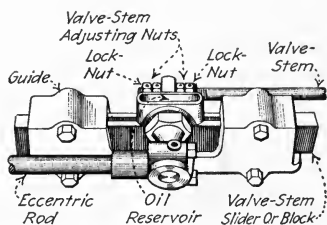

FIG. 159.—Valve-stem adjustment at the valve-stem slider. (Chuse engine & Mfg. Co.)

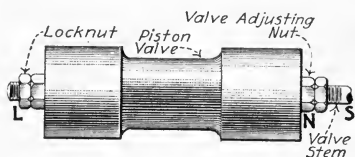

FIG. 160.—Method of adjusting valve-stem length at valve.

as measured along the valve mechanism, that is, by changing the *effective length of the valve stem*. Evidently, this length can be changed by altering either the distance from the eccentric center to the valve block, or the distance from the block to the valve. Each of these distances may, with certain engines be altered at either of the two ends of the rods which maintain the distances. On other engines, adjustment is provided only at one end of the valve stem or eccentric rod or at one end of each. Figs. 159 and 160 show means provided for this adjustment.

NOTE.—IN MOST SHAFT-GOVERNED ENGINES THE ANGLE OF ADVANCE CANNOT BE ADJUSTED, that is—the eccentric position is fixed by the governor. In these engines the valve is obviously only adjustable by altering the effective length of the eccentric rod and valve stem.

159. Table Showing Effects On the Steam-Engine Cycle Of Slide-valve Adjustments For The Outside-admission Slide Valve.

Adjustment		End of cylinder	Effect on valve events			
			Admission	Cut-off	Release	Compression
Valve-stem effective length	Lengthened	Head	Later	Earlier	Earlier	Later
		Crank	Earlier	Later	Later	Earlier
	Shortened	Head	Earlier	Later	Later	Earlier
		Crank	Later	Earlier	Earlier	Later
Angular advance of eccentric	Increased	Head	Earlier	Earlier	Earlier	Earlier
		Crank	Earlier	Earlier	Earlier	Earlier
	Decreased	Head	Later	Later	Later	Later
		Crank	Later	Later	Later	Later

NOTE.—TO USE THE ABOVE TABLE FOR INSIDE-ADMISSION VALVES bear in mind that: (1) Effects of changing effective valve-stem length are opposite to those given in the table. (2) Effects of changing the angular position (advance) of the eccentric are the same as for outside admission slide valves. It must not be forgotten, however, that for inside-admission valves (Sec. 151) the angle of advance is measured in the direction of rotation from a line 90 deg. *behind* the crank position to the line of the eccentric position.

160. In Setting The Valves Of A New Engine, before putting the engine into operation, do not at first change or disturb any adjustments of the valve mechanism. Remove the steam-chest cover and, turning the engine by hand, watch the motion of the valve upon its seat. With piston-valve engines the indirect-measurement method (Sec. 156) must be employed. Valve and seat dimensions may be obtained, without removing the valve from its seat, by consulting the engine-maker's blueprints. If, upon examination of the valve action with the cover removed, it is thought probable that the engine will run with the existing adjustment, replace the cover and start the engine. If desirable, the engine may be started without first examining the valve operation, as no harm can result even if the valves are not properly set. Then equip the engine with

indicators and take cards first under no load and then with gradually increasing loads. Engine builders usually carefully adjust the valves for their correct operation before shipping an engine. If, however (Sec. 112) the indicator diagrams reveal faulty valve motion *and not until then* it may be concluded that adjustment is necessary. The adjustment should be made in accordance with builder's instructions. If these instructions were not sent with the engine, they should be procured by writing to the factory. If valves must be set without specific instructions from the engine makers, the methods of succeeding sections may be employed.

161. In Setting The Valves Of An Old Engine, it is advisable to procure the manufacturer's instructions, if possible, and then to make the adjustments as recommended by the manufacturer. If it is impossible to obtain factory instructions, the valve may be set as hereinafter explained.

162. All Slide Valves May Be Set For One Of Three Conditions, any of which may give satisfactory operation. The ideal setting of engine valves is not attainable with a single valve because of the angularity of the connecting rod (Sec. 152). The setting of a slide valve must, therefore, be a compromise. The valve may be set for: (1) *Equal leads at both ends of the stroke.* This setting will make all events, especially cut-off, unequal for the two ends of the cylinder. (2) *Equal cut-offs, in per cent of stroke, during the forward and return strokes.* This setting will make all of the other events undesirably unequal for the two ends of the cylinder. (3) *Intermediate between equal leads and equal cut-offs.* By setting an engine for more lead at the crank end of the stroke than at the head end, the cut-offs are made more nearly equal for the forward and return strokes. Setting slide valves for each of these conditions will be discussed separately in following sections.

163. The First Step In Setting Any Slide Valve Is, therefore, to decide whether it is to be set for: (1) *Equal leads.* (2) *Equal cut-offs.* (3) *Intermediate between equal leads and equal cut-offs.* It really makes little difference which condition is selected. An engine will probably operate most quietly when set for equal leads. When set for equal cut-offs, it will probably operate most economically. A setting intermediate

between (1) and (2) provides reasonably quiet operation and good economy. But, in any case, the difference in the operating results obtained from any of the three methods of setting is usually very small. Therefore, since setting for equal leads is the easiest of the three, this condition is usually sought by operating engineers and is frequently recommended by engine builders, especially for small engines. For large engines condition (3) above is usually recommended. For vertical engines, the lead on the top or head end, is usually considerably less than on the bottom end because the cut-offs are so more nearly equalized and because the weight of the reciprocating parts acts against the steam pressure on the up stroke. Checking valve settings with an indicator is always the safest method of determining the proper leads for any given engine.

164. In Setting A Slide Valve For Equal Leads One Must First Decide Whether It Is To Be Set For "Design-Determined Equal Leads" Or For "Selected Equal Leads."—By *design-determined equal leads* is meant equal leads, be their amount what it may, the dimension of which was pre-determined by the designer of the engine and for which the angular advance of the eccentric—or its equivalent—has been permanently fixed. Hence, setting a slide valve for design-determined equal leads involves only changing the valve-stem or eccentric-rod effective length until the leads at both head and crank end are equal. To alter the amount of the equal leads which was thus predetermined and fixed by the designer of the engine, would necessitate changing the angular advance of the eccentric on the engine shaft. This would necessitate the cutting of a new shaft keyway or otherwise making mechanical changes in the engine which would involve more work than mere adjustments. By *selected equal leads* is meant equal leads the dimension of which is selected, by following a rule (as, for example, that of Sec. 165) by the person who is setting the valve. Setting for selected equal leads probably involves not only changing the valve-stem or eccentric-rod effective length but also changing the angular advance of the eccentric.

NOTE.—IN SETTING THE VALVE OF A SHAFT-GOVERNED ENGINE IT IS USUALLY DESIRABLE TO SET FOR DESIGN-DETERMINED EQUAL LEADS rather than for selected equal leads. As explained in Sec. 158, the eccen-

tric of a shaft-governed engine is not adjustable on the engine shaft. Hence, it is impossible, with an engine of this type to set, the valve for equal leads other than the "design-determined" lead for which the valve gear and governor was originally designed, without changing the position of the flywheel on the shaft. This will ordinarily necessitate the cutting of a new keyway in the shaft.

NOTE.—IT IS SELDOM ADVISABLE TO SHIFT THE ECCENTRIC (FLYWHEEL), OF A SHAFT-GOVERNED ENGINE, ON THE ENGINE SHAFT. This may appear to be necessary when it really is not, due to the governor being out of adjustment. See Div. 7 concerning shaft-governor adjustment. The eccentrics, and flywheels of shaft-governed engines are carefully located, in relation to the shaft, by their manufacturers before the engine leaves the factory. It is therefore seldom indeed that the shifting of the flywheel—which will necessitate the cutting of a new keyway in the shaft—is justified. If, after the governor has been correctly adjusted, and the leads are still of incorrect amount, then it may be necessary to shift the eccentric—fix the flywheel to the shaft in a new position.

165. The Proper Lead For Any Slide Valve should, finally, be determined with an indicator (Sec. 175). In general, the lead may be set at about $\frac{1}{32}$ in. for each foot of stroke—but it is seldom in any case that the lead should be much less than $\frac{1}{32}$ in. That is, an engine which has a 12-in. stroke should have a $\frac{1}{32}$ -in. lead. One which has a 24-in. stroke should have a $\frac{1}{16}$ in. lead and so on. If the selected lead is not the correct one for the engine, the indicator will reveal the remedy.

166. The Procedure To Be Followed In Setting Plain Slide Valves For Equal Leads is specified in Table 167. This table applies only to plain "D" or to plain piston slide valves; it does not apply, directly to riding-cut-off valves, for which see Sec. 172. See preceding sections for definitions of the terms "design-determined equal leads" and "selected equal leads." Always, when setting valves, turn the flywheel or the eccentric in the same direction, preferably in the direction in which they will move when the engine is running; see Sec. 153. Note that by changing the valve-stem—or eccentric rod—effective length, the leads at both head and crank ends may be made equal. When the valve opens an equal amount at each end, the eccentric rod and valve rod are then of correct length for equal leads. By shifting the eccentric on its shaft—changing its angular advance—the amounts of the equal leads may be altered.

167. Table Showing Procedure To Be Followed In Setting Plain Slide Valves For Equal Leads.—Read carefully the preceding section.

Operation		Steps to be taken									
		Engine has a throttling governor					Engine has a shaft governor				
Identifying letter	What to do	Eccentric is keyed to shaft		Eccentric is not keyed to shaft		Flywheel is keyed to shaft					
		For design-determined equal leads		For selected equal leads		For design-determined equal leads		For selected equal leads			
		I	II	III	IV	V	VI	VII	VIII	IX	X
		Direct valve	Indirect valve	Direct valve	Indirect valve	Direct valve	Indirect valve	Direct valve	Indirect valve	Direct valve	Indirect valve
A	Select equal lead dimension for which valve will be set, Sec. 165.	1	1	1	1	1	1
B	Establish dead centers and mark on flywheel, Sec. 153	1	1	2	2	2	2	1	1	2	2
C	Remove valve-chest cover or covers	2	2	3	3	3	3	2	2	3	3
D	Block shaft governor to normal operating position, Sec. 174.	4	4
E	Remove valve, measure it and, if desirable, make templet, Sec. 157.	..	3	..	4	..	4	..	3	..	5
F	Measure the valve seat and, if desirable, make templet, Sec. 157.	..	4	..	5	..	5	..	4	..	6
G	Replace valve on seat and connect it in proper running order to its valve stem.	..	5	..	6	..	6	..	5	..	7
H	Turn engine crank to its head-end dead-center position, Sec. 153.	3	6	4	7	3	6	5	8
I	Loosen eccentric and rotate it on its shaft to extreme head-end position, Sec. 154.	4	7
J	Measure accurately the lead or port opening at this end. Call it L_1 .	4	7	5	8	5	8	4	7	6	9
K	Rotate the eccentric to the extreme crank-end position, Sec. 154.	6	9

Operation		Steps to be taken									
		Engine has a throttling governor					Engine has a shaft governor				
Identifying letter	What to do	Eccentric is keyed to shaft		Eccentric is not keyed to shaft		Flywheel is keyed to shaft					
		For design-determined equal leads		For selected equal leads		For selected equal leads		For design-determined equal leads		For selected equal leads	
		I	II	III	IV	V	VI	VII	VIII	IX	X
		Direct valve	Indirect valve.	Direct valve	Indirect valve	Direct valve	Indirect valve	Direct valve	Indirect valve	Direct valve	Indirect valve
T	Fasten governor flywheel temporarily, but securely, to engine shaft in new position.	12	15
U	For a check, turn engine crank to its head-end dead-center position and measure the lead at this end also.	9	12	13	16	13	16	9	12	13	16
V	If the leads at the two ends are not equal, repeat such steps as you took, between <i>H</i> to <i>T</i> inclusive, until the leads are equal at both ends. This step should be unnecessary. This repetition is made necessary only by careless adjustment or by the insecure fastening of a part after adjustment.	10	13	14	17	14	17	10	13	14	17
W	Replace valve chest cover or covers.	11	14	15	18	15	18	11	14	15	18
X	Check your valve setting with an indicator; see Sec. 175.	12	15	16	19	16	19	12	15	16	19
Y	Cut new eccentric key-way in the engine shaft, if necessary, for a permanent attachment and key eccentric thereto in the new position.	17	20
Z	Cut new governor flywheel keyway in engine shaft in new position if necessary for a permanent attachment and key flywheel thereto; see Secs. 164 and 174.	17	20
A	Make valve-setting reference tram and spot tram-reference marks on valve stem and stuffing box. These are to insure rapid future resetting of the valve.	13	16	18	21	17	20	13	16	18	21

NOTE.—IF THE STEAM PORT IS OPENED MORE IN THE SECOND DEAD-CENTER POSITION THAN IN THE FIRST, it is an indication this applies only to direct or outside admission valves) that the valve stem too long and that it must be shortened by $\frac{1}{2}$ the difference in the the amounts of the leads. *If the lead is less in the second dead-center position than in the first* or if the steam port is not uncovered at all, the valve stem is too short and must be lengthened; thus: (a) if the steam port is opened, the valve stem must be lengthened by $\frac{1}{2}$ the difference between the leads at the two ends; (b) if the steam port is not opened, the valve stem must be lengthened by $\frac{1}{2}$ the amount by which the valve falls short of opening it plus $\frac{1}{2}$ the lead at the first dead-center position. After the valve stem has been lengthened by the correct amount as directed in (b) the valve may not show any lead at all.

EXAMPLE.—SETTING THE VALVE OF A THROTTLING-GOVERNED PLAIN-INDIRECT-VALVE (PISTON-VALVE) ENGINE FOR SELECTED EQUAL

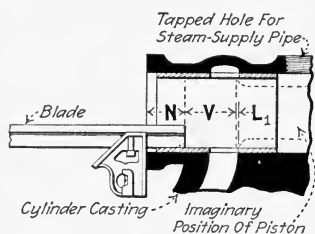

FIG. 161.—Showing how a combination square and blade are used for making indirect measurements.

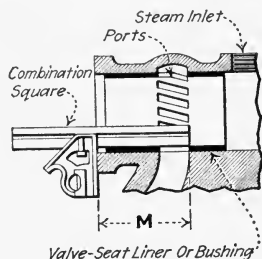

FIG. 162.—First adjustment of square—blade end against inner edge of steam port.

LEADS. ECCENTRIC IS NOT KEYED TO SHAFT. Follow the steps of Column VI, Table 167. The exhaust ports are not shown in any of the illustrations in this example. (1) Select the equal lead, which will be designated by " L_s ," for which you wish to set the valve, as directed in Sec. 165; assume that it is to be $\frac{1}{32}$ in. (2) Establish and mark the dead-center position on the engine flywheel as directed in Sec. 153.

(3) Remove the valve-chest covers. (4) Remove the valve and measure the length, V , as shown in Fig. 161, of the piston; say it is $2\frac{1}{2}$ in.

(5) Measure with a combination square, as shown in Fig. 162, the distance to the inner edge of the steam port. Call the distance M ; say it is $4\frac{1}{2}$ in. If the steam chest is not alike at both ends, measure similarly and record the corresponding distance M for the other end of the chest.

(6) Replace the valve in its seat and connect it in proper running order to its valve stem; the valve stem will be adjusted to proper effective length in the next steps.

(7) Loosen the eccentric and rotate it on the engine shaft to its extreme head-end position as shown in Fig. 163; see Sec. 154. It is desirable

that, in this step, the steam port be opened wide as the only object of the step is to insure that the valve opens both the head-end and the crank-end ports by equal amounts. (8) The amount, or its equivalent, by which the head-end port is opened is determined by indirect measurement

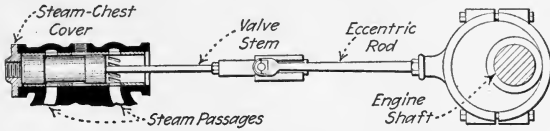

FIG. 163.—Eccentric in head-end extreme position.

thus: The eccentric being in its extreme head-end position, as in Fig. 163, set the combination square as shown in Fig. 164 and measure the distance N ; say it is $\frac{3}{8}$ in. Then, at this head end, the port opening, $L_1 = M - (N + V) = 4\frac{1}{2} - (\frac{3}{8} + 2\frac{1}{2}) = 4\frac{1}{2} - 2\frac{7}{8} = 1\frac{5}{8}$ in., as shown in Fig. 164.

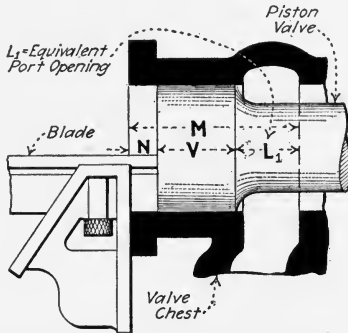

FIG. 164.—Measuring L_1 for head end; $L_1 = M - (N + V)$.

(9) Rotate the eccentric on the engine shaft to its extreme crank-end position, as shown in Fig. 165. (10) Measure the lead, L_2 , for this crank end by the same indirect method as that which was used for the head end. If this L_2 happens to be the same amount as L_1 , the leads are equal at

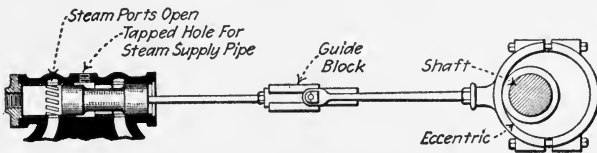

FIG. 165.—Eccentric in crank-end extreme position.

both ends which shows that the valve-stem effective length is correct. But if they are not equal, the valve-stem length will have to be changed. Assume that, in this example, the crank-end port opening, L_2 , is found to measure $1\frac{1}{2}$ in. (11) Then, to be equal at each end, the openings must

be changed to $L_3 = (L_1 + L_2)/2 = (1\frac{5}{8} + 1\frac{1}{2}) \div 2 = 3\frac{1}{8} \div 2 = 2\frac{5}{16} = 1\frac{9}{16}$ in.

(12) To make the openings $1\frac{9}{16}$ in. at each end, the valve-stem effective length must be changed by an amount equal to half the difference between L_1 and $L_2 = (1\frac{5}{8} - 1\frac{1}{2}) \div 2 = \frac{1}{8} \div 2 = \frac{1}{16}$ in. If the head-end port is opened the widest, the valve-stem should be shortened—if there is no rocker arm in the valve mechanism. If the crank-end port is opened furtherest, then the valve-stem length should be lengthened. After the valve-stem effective length has thus been changed by $\frac{1}{16}$ in., then its length insures that the crank-end and head-end steam ports will always have equal leads; this regardless of the amount of the selected lead, the setting for which is made, in the second step following, by cranking the angle of advance of the eccentric.

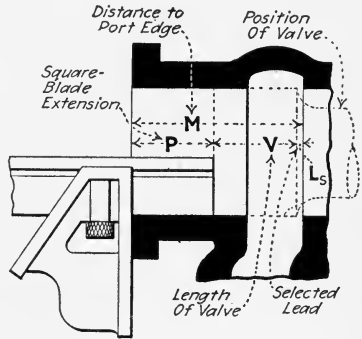

FIG. 166.—Setting piston valve for selected lead. $P = M - (V + L_s)$.

(13) Turn the engine to its crank-end dead-center position. (14)

Change the angle of advance so that the equal lead at both crank and head ends will be the selected lead, $L_s = \frac{1}{32}$ in. Proceed thus: Set the combination square, as shown in Fig. 166, so that the extending portion of the blade, $P = 1\frac{31}{32}$ in. That is, from Fig. 166, $P = M - (V + L_s) = 4\frac{1}{2} - (2\frac{1}{2} + \frac{1}{32}) = 4\frac{1}{2} - 2\frac{17}{32} = 1\frac{31}{32}$ in. Rotate the eccentric on its shaft to the crank-end extreme position, as shown in Fig. 163. Place the extending blade of the combination square, which has been set at $1\frac{31}{32}$ in. as just described, into the valve cylinder as shown in Fig. 167. Rotate the eccentric on its shaft in the direction the engine is to

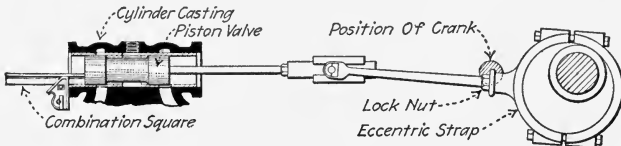

FIG. 167.—Head-end port opened to the extent of the lead.

run until the left end of the valve is just about to leave the square-blade end. The eccentric should now be in the correct position for permanent setting for the selected lead of $\frac{1}{32}$ in. (15) Fasten the eccentric securely to the shaft in this new position; the valve should now be set properly.

(16) To check the setting for accuracy, turn the engine to the head-end dead-center position and also measure, as described in 14, the lead at this

end. If the valve chest is not the same at both ends, it will be necessary to reset the combination square accordingly, in order to make the measurement. (17) If the lead at both ends is now the selected lead of $\frac{1}{32}$ in., you are through. If it is not $\frac{1}{32}$ in. at both ends, you have made some error and if so repeat the necessary preceding steps until the lead at both ends is $\frac{1}{32}$ in.—or is the selected lead whatever it may be.

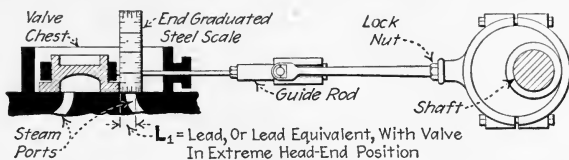

Fig. 168.—Determining L_1 —eccentric of a plain slide-valve engine in extreme head-end position. (Exhaust port not shown.)

(18) Replace the valve chest covers. (19) Check your setting with an indicator, if possible. (20) If desirable, spot reference marks, as elsewhere explained, to facilitate future rapid setting of the valve.

EXAMPLE.—SETTING THE VALVE OF A THROTTLING-GOVERNED, PLAIN-D-SLIDE-VALVE (DIRECT-VALVE) ENGINE FOR SELECTED EQUAL LEADS. ECCENTRIC IS NOT KEYED TO SHAFT. Follow column V of Table 167.



Fig. 169.—Steel scale having end graduations. (Brown & Sharpe Co.)

A 24-inch stroke engine is to be set for equal selected leads. Proceed as follows: (1) Select the amount for the equal lead: From Sec. 165, the proper lead for an engine is about $\frac{1}{32}$ in. per foot of stroke; hence, for this engine the proper lead, which will be designated by " L_s ," is $\frac{1}{16}$ in. (2) Establish and mark the dead-center points on the flywheel; see Sec. 153. (3) Remove valve-chest cover. (4) Loosen the eccentric and rotate it on the engine shaft to its extreme head-end position, as shown in Fig. 168.

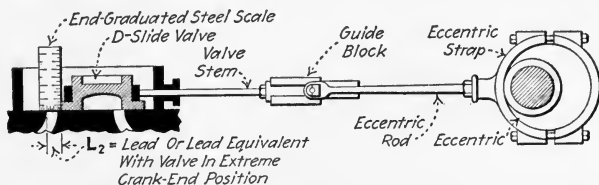

Fig. 170.—Determining L_2 —eccentric of a plain slide-valve engine in extreme crank-end position. (Exhaust port not shown.)

(5) Measure the port opening, as shown in Fig. 168 at this head end; call it L_1 ; say it is $\frac{5}{8}$ in. A steel scale which has end divisions, as in Fig. 169, is convenient for making such measurements. (6) Rotate the eccentric on the engine shaft to its extreme crank-end position as shown in Fig. 170. (7) Measure the port opening, L_2 , at this crank end. If this

L_2 happens to be the same amount as L_1 , the port openings at both ends are equal which shows that the valve-stem effective length is correct. But if they are not equal, the valve-stem effective length will have to be changed. Assume that, in this example, the crank-end port opening; L_2 , is found to measure $1\frac{1}{16}$ in. (8) The difference between L_1 and $L_2 = \frac{1}{16} - \frac{5}{8} = 1\frac{1}{16} - 10\frac{0}{16} = \frac{1}{16}$ in.

(9) Then, to be equal at each end, the openings must be changed to $L_3 = (L_1 + L_2) / 2 = (1\frac{1}{16} + 10\frac{0}{16}) \div 2 = 21\frac{1}{16} \div 2 = 2\frac{1}{32}$ in. To make the openings $2\frac{1}{32}$ in. at each end, the valve-stem effective length must be changed by an amount equal to half the difference between L_1 and $L_2 = \frac{1}{16} \div 2 = \frac{1}{32}$ in. Hence, the valve-stem effective length must be changed by $\frac{1}{32}$ in. After the valve-stem effective length has thus been changed by $\frac{1}{32}$ in., then its length insures that the crank-end and head-end steam ports will always have equal leads; this regardless of the amount of the selected lead, the setting for which is made, in step 11, by changing the angle of advance of the eccentric.

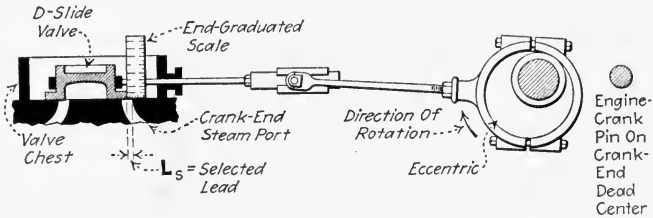

FIG. 171.—Setting a plain slide valve for a selected lead, L_s . (Engine is in crank-end dead-center position.)

(10) Turn the engine to its crank-end dead-center position. (11) Change the angle of advance so that the equal leads at both crank and head ends will be the selected lead, $L_s = \frac{1}{16}$ in. Proceed thus: Place the eccentric on the shaft about as shown in Fig. 170 and rotate it on the shaft, in the direction that the engine is to run until the crank-end port is, see Fig. 171, open just the $\frac{1}{16}$ in., as shown by measurement with an end-divided steel scale. (12) Fasten the eccentric securely to the shaft in this new position; the valve should now be set properly.

(13) To check your setting for accuracy, turn the engine to its head-end dead-center position and also measure similarly the lead now shown there. (14) If the lead at both ends is now the selected lead of $\frac{1}{16}$ in., you are through. If it is not $\frac{1}{16}$ in. at both ends, you have made some error and must repeat the necessary preceding steps until the lead at both ends is $\frac{1}{16}$ in.—or is the selected lead whatever it may be. (15) Replace the valve-chest cover. (16) Check the valve-setting with an indicator, if possible. (17) If desirable, spot reference marks, as elsewhere explained, to facilitate future rapid setting of the valve.

EXAMPLE.—SETTING THE VALVE OF A SHAFT-GOVERNED, PLAIN, INDIRECT-VALVE (PISTON-VALVE) ENGINE FOR DESIGN-DETERMINED

EQUAL LEADS. (This has been modified from an article in *Southern Engineer* for November, 1919, to follow the procedure which is specified in Column VIII of Table 167). When proper reference marks have, as hereinafter described, been made on the valve stem and seat, the valve may be set very readily and quickly. But when these marks do not appear and no templets (Sec. 157) are available, the following method may be pursued. The exhaust port is not shown in any of the illustrations. The numbers in parentheses refer to the step numbers in Table 167:

(1) Scribe the dead-center marks on the flywheel as explained in Sec. 153. (2) Remove the valve-chest covers. (3) Take out the valve and measure the length (V , Fig. 161) of its piston portion; say it is $2\frac{1}{2}$ in. (4) Adjust a combination square to the length shown in Fig. 162 with the inner end of its blade against the inner edge of the steam port; measure this distance, M ; say it is $4\frac{1}{2}$ in. If the chest is not alike at both ends, measure, similarly, the corresponding distance for the other end of the chest. (5) Replace the valve in its chest and connect it in running order to the valve stem. (6) Turn the engine in its running direction to exact head-end dead-center position.

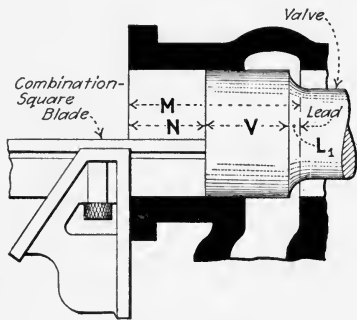

FIG. 172.—Measuring lead. $M = N + V$
 $+ L_1$ or, $L_1 = M - (N + V)$.

(7) Measure, with the combination square, as shown in Fig. 161, the distance, N , to the valve end; say it is $1\frac{3}{32}$ in. Now obviously the lead existing on this end is, see Fig. 172, $L_1 = M - (N + V) = 4\frac{1}{2} - (1\frac{3}{32} + 2\frac{1}{2}) = 4\frac{1}{2} - 4\frac{7}{16} = \frac{1}{32}$ in. (8) Turn the engine to the crank-end dead-center position. (9) Similarly, measure the lead, L_2 , at this crank end. If L_2 happens to be the same as L_1 , the engine is set for equal design-determined leads. But assume that, in this example, the lead, L_2 , at the crank end is found to be $\frac{3}{32}$ in. (10) The difference between L_1 and L_2 is $\frac{3}{32} - \frac{1}{32} = \frac{1}{16}$ in. (11) Then the proper design-determined equal lead, $L_3 = (L_1 + L_2)/2 = (\frac{1}{32} + \frac{3}{32}) \div 2 = \frac{1}{8} \div 2 = \frac{1}{16}$ in.

To provide this $\frac{1}{16}$ in. equal lead, the valve-stem effective length must be increased by an amount equal to half the difference between L_1 and $L_2 = (\frac{3}{32} - \frac{1}{32}) \div 2 = \frac{2}{32} \div 2 = \frac{1}{32}$ in. Hence, after a change of $\frac{1}{32}$ in. in the valve-stem effective length, the engine valve should be properly set for design-determined equal leads. Measure, as explained above, the new lead L_3 to be sure that it is $\frac{1}{16}$ in. at this crank end.

(12) Now, for a check, turn the engine again to the head-end dead-center position and by measurement, as before, check the new lead L_3 for the head end. (13) If the leads at both ends are equal, you are through.

If they are not equal, you have made some error and must repeat the necessary preceding operations until the leads are equal. (14) Replace the valve-chest covers. (15) Check your setting with an indicator if possible. (16) If desirable, spot reference marks, as explained below, to facilitate future rapid setting of the valve.

EXAMPLE.—THE SPOTTING OF TRAM REFERENCE MARKS, TO ENABLE ONE TO QUICKLY MAKE FUTURE VALVE SETTINGS WITHOUT REMOVING THE CHEST COVERS, is effected as follows: It is assumed that the valve

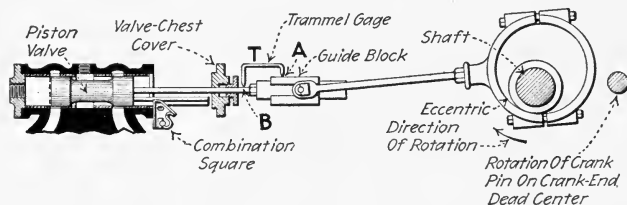

FIG. 173.—“Trying” the lead at the crank end of the piston-valve cylinder (engine on crank-end dead center).

has been correctly set as described above. Make a trammel gage (*T*, Fig. 173) by pointing the two ends of a piece of steel wire and bending it into trammel form. The size of the trammel—the distance between the trammel points—may be any that is feasible and convenient. With a center punch, spot a mark at *A* on the guide block. Place one point of the trammel in this mark, *A*, and then spot another very light mark, *B*, where the other point of the trammel gage touches the valve stem. These reference marks used in conjunction with the trammel gage enable one to disconnect the valve stem from the stem guide block and to then

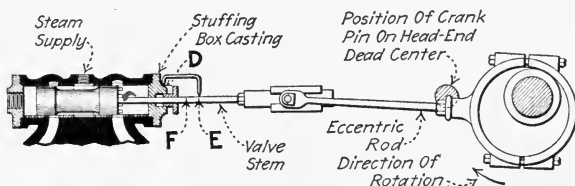

FIG. 174.—Locating prick-punch marks, for future valve settings, on valve stem and stuffing box. (Engine on head-end dead center.)

replace the valve (in case it was necessary to entirely remove the valve) and to reconnect the valve stem in exactly its original position.

Having made the trammel gage and used it as in Fig. 173, now again use it (Fig. 174) for spotting the slide-valve-lead reference marks. Place the engine crank on exact head-end dead center. Then spot a center punch mark, *D*, (Fig. 174) on the stuffing box—not on the gland. Place one end of the trammel gage in this mark and spot another mark, *E*, on the valve stem where the other point of the trammel touches the stem.

When testing to verify the setting of the valve: First, place the crank on the head-end dead center. Then, with one point of the trammel gage in the mark, *D*, the other gage point should lie exactly in the punch mark, *E*. If the other point does not lie in *E*, the valve setting is out of adjustment. With the gage points in *D* and *E*, assuming that the original correct adjustment has not been altered, the valve will have opened the

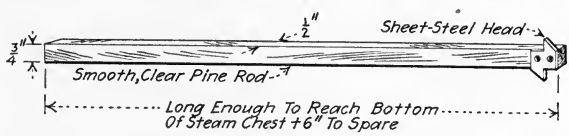

FIG. 175.—Measuring rod for measuring steam-port opening.

head-end port to the amount of the desired lead—because the valve was in this position when the gage and the marks *D* and *E* were first made. The trammel gage should be carefully preserved so that in future emergencies, such as the slipping of an eccentric, the valve can be promptly readjusted to its correct relation.

EXAMPLE.—HOW TO MAKE THE VALVE-SETTING TEMPLETS FOR A PLAIN INDIRECT-VALVE (PISTON-VALVE) ENGINE will be explained: While these directions relate specifically to a vertical engine they may, with obvious modifications, be applied to a horizontal engine. Compare this method with the similar method suggested in Sec. 157 and that described in the following example for a riding-cut-off piston valve; all of

these three methods vary only in detail procedure, the final result accomplished in each being essentially the same. Each method has its applications.

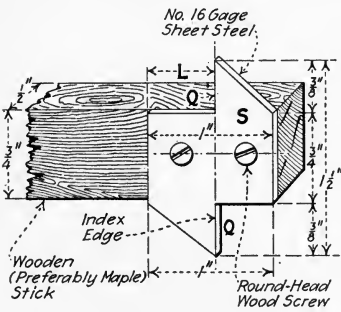

FIG. 176.—Head of measuring rod.

dimension *L* should be at least $\frac{1}{16}$ in. less than the width of the engine steam ports.

Prepare The Sticks From Which The Templets Will Be Made. Two pieces of smoothed clear pine, each about $\frac{1}{2}$ in. thick and about 1 in. wide will be required. Both should, at the start, be about the same length as the measuring rod. All faces and ends should be square and true.

Prepare To Measure The Valve Chest.—Remove the valve-chest cover and the valve-stem stuffing-box gland. Disconnect and remove the valve from the valve chest.

Make The Steam-Port Templet.—Insert the measuring rod into the valve chest so that one of its index edges (*Q*, Fig. 176) is against the furthest edge of the farthest steam port (Fig. 177, I). With a knife blade, cut a

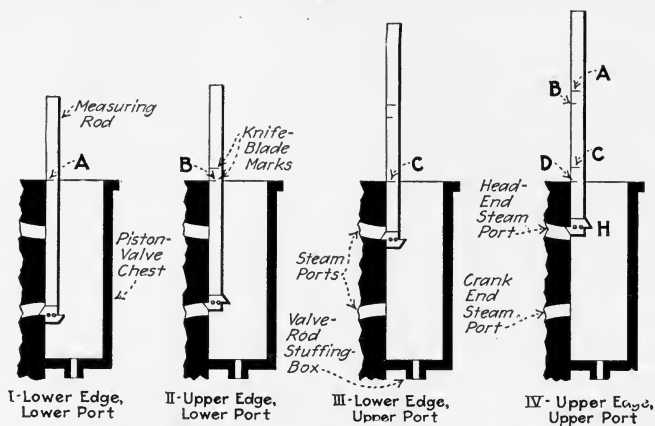

FIG. 177.—Marking steam-port locations and widths of a vertical-engine valve chest on a measuring rod.

corresponding line, *A*, on the face of the rod exactly at the level of the valve-chest face. Similarly, locate on the measuring rod (as shown in Fig. 177, II, III, and IV) lines *B*, *C* and *D*, which respectively correspond to the other edges of the steam ports. Now, as shown in Fig. 178, lay one of the sticks, which was prepared as above, on the measuring rod. With a try square and knife blade transfer the lines from the measuring rod to the $\frac{1}{2}$ in. face of the stick. In the illustrations, the width of the

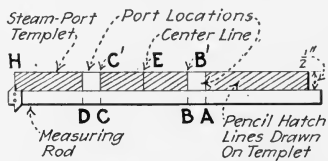

FIG. 178.—Laying off the steam-port templet.

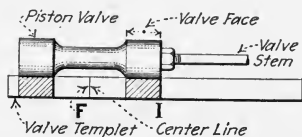

FIG. 179.—Laying off the valve templet.

sticks is shown exaggerated for clearness. Draw pencil "hatch" lines on those portions of the stick's face which do not represent the ports. Draw, midway between *C'* and *B'* a knife-cut center line, *E*, across the stick's face. This completes the steam-port templet.

Make The Valve Templet.—Lay the piston valve (Fig. 179) on the 1-in. face of the other stick which was previously made. The left end of the

valve should lie about $\frac{1}{2}$ in. from the left end of the stick. Transfer to the $\frac{1}{2}$ -in. face of the stick lines representing the locations of the edges of the valve faces, as shown in Fig. 179. Draw a center line, *F*, midway between the two sets of lines which represent the valve edges. Hatch, with pencil lines, the portions of the stick's face which represent metal.

The Valve Templet Must Be Of A Certain Length so that, when in use (Fig. 180) for valve setting, it will reproduce accurately the events which are occurring in the steam chest. When in use, the lower end of the valve templet rests on the upper end of the valve, while the valve is shifted

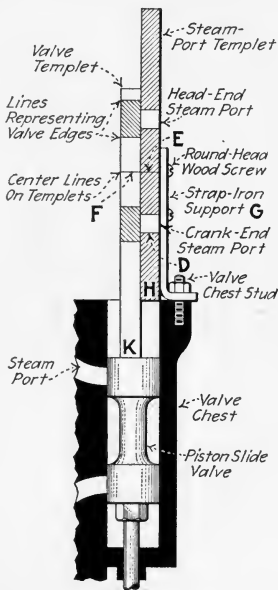

FIG. 180.—Templets arranged on valve chest for valve setting.

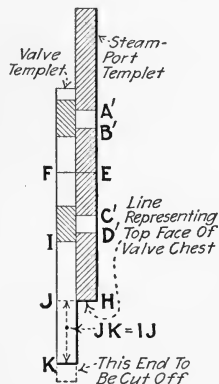

FIG. 181.—Measuring valve templet to cut it off to proper length.

vertically to different positions. The valve templet slides alongside the steam-port templet. To determine the proper length of the valve templet proceed thus: Lay the steam-port templet against the valve templet (Fig. 181), with their two center lines *F* and *E* exactly in line. Now, as is evident from Figs. 177 IV and 178, the distance *EH* on the steam-valve templet equals the actual distance from the horizontal center line between the steam ports to the top face of the steam chest. Also, the distance *FI* on the valve templet equals (See Figs. 179 and 181) the actual distance between the horizontal center line of the valve and either end face of the valve. Hence, from Fig. 181, it follows that *IJ* is the distance which the top face of the piston valve must lie below the top face of the valve chest when the valve is vertically central in the valve chest in relation to the

ports. Now lay off on the valve templet below *J* a distance *JK*, which is equal to *IJ*. Cut the templet off square at *K* and it will be complete and of correct length.

Arrange The Templets On The Engine Valve Chest.—Bend a piece of strap iron to form a support, *G*, (Fig. 180) for the steam-port templet. Drill the short leg of the support to accommodate one of the valve-chest studs and drill the long leg to take three round-head wood screws. Replace and reconnect the valve in the chest. Secure the steam-port templet to the valve chest as shown in Fig. 180, with the “*H*” end of the steam-port templet exactly on a horizontal line with the top face of the steam chest. Now place the valve templet alongside of the steam-port templet (Fig. 180) with the lower end, *K*, of the valve templet resting on the upper face of the valve. The end *K* should always, when the templets are in use, rest on the upper end of the valve. Now, if the templets have been accurately made they will visibly reproduce, outside of the steam chest, the invisible events which are occurring within it.

To Use The Templets For Valve Setting, it is merely necessary to follow the directions of Table 167 and measure the valve events which occur from the templets—instead of measuring them directly from the actual valve and ports. After the valve has once been set correctly, it may be desirable to label and retain the templets for future use. But, if the proper trammel is made and center-punch reference marks are spotted on the valve stem as described in other examples, the use of the templet for resetting will be unnecessary.

168. Setting A Slide Valve For Equal Cut-Offs has definite limitations. For instance, a valve designed for a nominal cut-off of, say, $\frac{6}{10}$ stroke could not give satisfactory operation if set for $\frac{4}{10}$ or $\frac{8}{10}$ cut-off at each end. In setting for equal cut-offs, one must not attempt to depart very far from the nominal cut-off for which the engine was designed. The following procedure is intended to give a practical means for setting slide valves for equal cut-offs which will give satisfactory operation.

- (1) Set valve for proper equal leads by Table 167.
- (2) Scribe a mark, *A*, (Fig. 182) at some convenient place on crosshead.
- (3) Place engine on crank-end dead center.
- (4) Scribe a mark, *B*, on the crosshead guide opposite *A* on the crosshead.
- (5) Turn engine slowly in direction it is to run until the valve just closes the crank-end cylinder port to live steam.
- (6) Scribe a mark, *C*, on the crosshead guide opposite *A* on the crosshead.
- (7) Turn engine to head-end dead center.

(8) Scribe a mark, *D*, on the crosshead guide opposite *A* on the crosshead.

(9) Scribe another mark, *E*, making $DE = BC$.

(10) Turn engine in direction it is to run until *A* stands opposite *E* on the guide.

(11) Change effective valve-stem length sufficiently to half close the cylinder port.

(12) Move eccentric on shaft (opposite to engine rotation) to just close the cylinder port.

(13) Turn engine in direction it is to run until cut-off again takes place at the crank end.

(14) If *A* is not opposite *C*, repeat steps (6) to (13).

(15) Check valve setting with an indicator (Sec. 175).

NOTE.—SETTING FOR EQUAL CUT-OFFS IS A CUT-AND-TRY ADJUSTMENT, it being necessary usually to repeat steps (6) to (13) several times before the adjustments are correct.

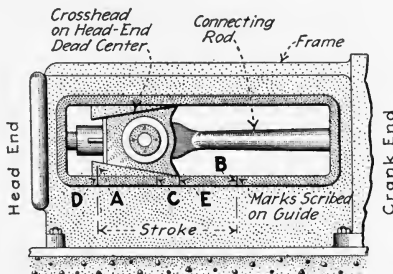

FIG. 182.—Method of marking crosshead guides for setting valve for equal cut-offs.

169. The General Procedure In Setting A Slide Valve For An Intermediate Between Equal Leads And Equal Cut-Offs differs from that for equal leads (Sec. 167) only in that the adjustment is made for definite unequal leads. The lead at the head end is made a little less, and that at the crank end a little more, than the value recommended in Sec. 165. The difference between the leads at the two ends should be approximately $\frac{1}{16}$ in. for each foot of stroke. The result of this difference is to eliminate the lead at the head end (make it zero) and, at the crank end to double the value given in Sec. 165. The Ridgway Engine Co. recommends, for engines of 14 in. stroke and smaller that the lead should measure $\frac{1}{32}$ in. more at the crank than at the head end and for larger engines $\frac{1}{16}$ in. more at the crank than at the head end. The procedure therefore becomes:

- (1) Establish dead centers (Sec. 153).
- (2) Remove valve-chest cover.
- (3) If engine has shaft governor, it may be necessary to block the governor to its normal operating position (See Sec. 174).
- (4) With indirect valve, remove the valve and measure it. If necessary make templet (Sec. 157).
- (5) With indirect valve, measure valve seat and, if necessary make templet (Sec. 157).
- (6) Replace valve on seat.
- (7) Set engine on head-end dead center.
- (8) Rotate eccentric on shaft, in direction engine is to run, until the lead at head end is, say, $\frac{1}{8}$ in.
- (9) Measure accurately the lead at this end. Call it L_1 .
- (10) Fasten eccentric to shaft.
- (11) Turn engine to crank-end dead center.
- (12) Measure lead at crank end. Call it L_2 .
- (13) Change lead at this end so that $L_2 - L_1 = K =$ the proper difference between the leads at the two ends. Make the adjustment by changing the valve-stem length.
- (14) Shift eccentric to attain the required lead at this (crank) end.
- (15) Replace valve-chest cover.
- (16) Check setting with indicator (Sec. 175).

NOTE.—WHEN VALVES ARE THUS SET FOR UNEQUAL LEADS THE RESULTING INDICATOR DIAGRAMS WILL SHOW admission occurring too early at the crank end and too late at the head end. This must be tolerated because it is a consequence of the valve setting. Should the engine, however, appear to “pound” at the crank end, the eccentric must be turned backward on the shaft or the valve-stem length must be changed until the pounding stops.

170. Multiported Valves Are Set by following the same general rules as outlined from Sec. 167 to Sec. 169. Multiported valves are generally so designed that cut-off and the other events occur at each valve port at the same time. For example, Fig. 183 shows that head-end admission will occur at the same time past edges A and B. Obviously cut-off must occur at these edges at the same time. Therefore the setting of valves of this type requires no special explanation. Each particular valve

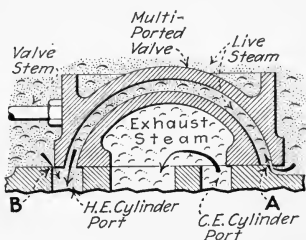

FIG. 183.—A multiported slide valve at the point of head-end admission.

should be examined for peculiarities. Templets may be made of the valve and the seat to facilitate future setting.

171. A Method Of Setting Any Slide Valve Without Removing The Steam-Chest Cover (*Power*, Nov. 15, 1921) is described below. This applies to plain *D*, piston, balanced, and multiported slide valves—in fact to any slide valve. However the method can be used effectively only for engines which have little or no valve leakage; this restricts it, largely, to relatively-new or to recently-overhauled engines.

EXPLANATION.—*If there is a rocker for transmitting motion of the eccentric to the valve rod*, for the best valve setting the length of the eccentric rod should be so adjusted that the rocker will swing approximately as far to one side as to the other of that position in which it would be at right angles to the valve rod. After the length of the eccentric rod has been thus adjusted, the valve setting is completed by adjusting the valve rod to such length that one end of the valve will travel over the opening edge of its steam port as much as the other end of the valve will travel over the opening edge of its port and then with the engine on a center, setting the eccentric to that position which will give the valve the desired amount of lead. How this may be done is explained below.

If the valve-rod length cannot be adjusted outside of the stuffing box, it will be necessary for good valve setting to remove the steam-chest cover for that purpose. But where the rocker would be thrown only slightly out of perpendicular to the valve rod by adjusting the length of the eccentric rod, then a fair valve setting can be effected by simply adjusting the length of the eccentric rod for equalizing the travel of the valve without opening the steam chest. Or in case there is no rocker, the equalization of valve travel can be effected by adjusting either the length of the valve rod or the length of the eccentric rod, without removing the steam-chest cover.

For testing the equalization of valve travel without opening the steam chest: Place the engine on a center, make a mark on the guide to correspond with a mark on the crosshead. Temporarily fasten the eccentric on the shaft in that position which will just permit steam to be blown through the port at the same end. Then, turn the flywheel forward to the position where, by opening the throttle valve, very little steam is shown by the pet cock to be admitted to the other end of the cylinder. Make a mark on the guide to correspond with the mark on the crosshead. Also make another mark with the engine on dead center at the same end of the cylinder. Also make a mark on the guide halfway between the marks last made on the guide. Then turn the engine wheel to such a position that the mark on the crosshead will be opposite to this middle mark. Adjust the length of the valve rod or eccentric rod so steam will be just admitted on the same end.

Next turn the engine forward toward the other center until the mark on the crosshead comes the same distance from the end of the stroke as the middle mark is from the other end. If steam is just admitted the travel has been equalized. If not, turn the engine to the position where steam is just admitted. Make another mark on the guide halfway between the position where steam was admitted and the position where it should have been admitted. With the crosshead set at this middle mark, readjust the valve-rod or eccentric-rod length until steam is admitted at that end of the cylinder.

Now set the valve for the desired amount of lead. With the valve travel thus equalized, place the engine on the head-end center. Turn the eccentric forward on the shaft, and set the eccentric to the position at which steam is just admitted to the head end of the cylinder. Then make a mark on the valve rod exactly 1 in. out from the end of the stuffing-box gland. Shift the eccentric as much farther forward on the shaft as may be necessary to shift the mark made on the valve rod by a distance equal to the desired amount of lead.

172. Setting A Riding Cut-Off Valve Mechanism must, since it contains two valves, be accomplished in two steps,

(1) **THE MAIN VALVE IS SET** for equal leads by the method of Table 167 or as follows: Rotate the eccentric from one extreme position to the other to see that both cylinder ports are opened to the same extent.

If they are not, adjust (Table 167) the valve-stem effective length until they are. Whether they open exactly to their total width is not important. Then put the engine crank on the head-end dead center and have the eccentric rotated, in the direction in which the engine is to run, until the head-end cylinder port begins opening and is open by the amount of the lead (usually $\frac{1}{32}$ in.). This may often be determined by observing the cylinder port through the port in the main valve. Then fasten the eccentric securely to the shaft. The valves of a piston-valve engine must be set by an indirect method, such as that which is described in the following example.

(2) **SETTING THE CUT-OFF VALVE** is dependent upon whether the cut-off valve is (a) *hand-adjustable*, (b) *governor-operated*, (c) *neither hand-adjustable nor governor-operated*. In any one of these three constructions the first step is to adjust the valve-stem length. To do this, place the main valve in its mid-travel position and turn the cut-off eccentric. The cut-off valve should travel equal distances beyond the two ports of the main valve. If it does not do this, adjust the effective valve-stem length until it does.

(a) *If the cut-off valve is hand-adjustable*: Make marks *A* and *D* (Fig. 182) on the crosshead and guide to represent the head end of the stroke. With the engine still on head-end dead center, place the cut-off eccentric on its crank-end center (Sec. 154) and fasten it there by tightening its set screws. Now measure two-thirds stroke, *DE*, from the head-end

mark *D* on the crosshead guide and make another mark, *E*, on the guide. Turn the engine in the direction it is to run to bring the crosshead mark *A* to this last-made mark, *E*, on the guide. Then adjust the position of the cut-off valve on its stem (by the handwheel, Fig. 184) until it just closes the head-end port of the main valve. This completes the setting.

(b) *If the cut-off valve is governor-operated:* With the governor connected up and its weights resting at their inner positions, turn the flywheel until cut-off occurs and measure the fraction of stroke at which this occurs. Do this for the forward and return strokes. The fractions should be equal if the valve stems are of proper length. If the fractions are unequal they may be equalized by changing the effective length of the cut-off valve stem. Then, the governor springs should be disconnected and the weights blocked out against their stops. Turning the flywheel now should not cause the cut-off valve to uncover the ports of the main valve at any position during the revolution.

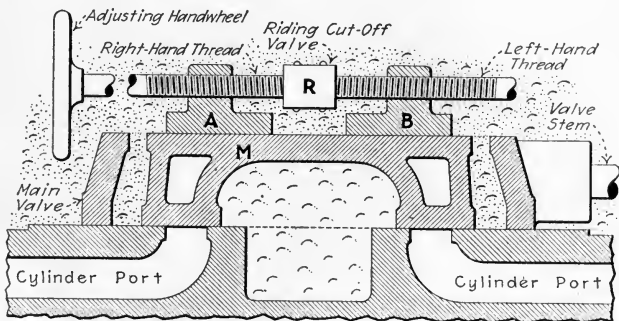

FIG. 184.—Section of a Meyer riding-cut-off valve.

(c) *If the cut-off valve is neither hand-adjustable nor governor-operated:* Place the engine on head-end dead center and the cut-off eccentric on its crank-end center and fasten it there, just as in (a). Now turn the engine ahead for $\frac{2}{3}$ stroke (or whatever fraction of stroke at which cut-off is desired) of the crosshead, as in (a). Now loosen the cut-off eccentric and shift it ahead (in the direction the crank is to turn) until it closes the head-end port in the main valve. Then fasten the eccentric securely. The setting is thus completed.

The following example illustrates the application of the preceding rules to the setting of a riding-cut-off piston-valve engine's valves.

EXAMPLE.—SETTING THE VALVES OF A SHAFT-GOVERNED PISTON-RIDING-CUT-OFF-VALVE ENGINE for selected equal leads. This is based on the directions in an article in *Southern Engineer* for December, 1919. An indirect method (Sec. 156) must be employed. While the detail procedure herein outlined is not exactly the same as that specified in the general directions of Sec. 172 above, the result which is attained is the same.

These directions relate specifically to an engine of "Buckeye" construction, the valve and cylinder arrangement of which is shown in Fig. 185. There are two piston valves, V_1 and V_2 (Fig. 185) one working within the other. The working edges of neither are visible when one is setting the valves. The cylindrical end portions, E , of the main valve, V_1 , form two smaller valve chests for the cut-off valve. The two cup-like ends of the main valve are retained in correct relation by three rods, R , which tie the ends together. The hollow main-valve stem, M , is screwed into that main-valve head which lies nearest the crank. The cut-off-valve stem, C , slides longitudinally within the main-valve stem.

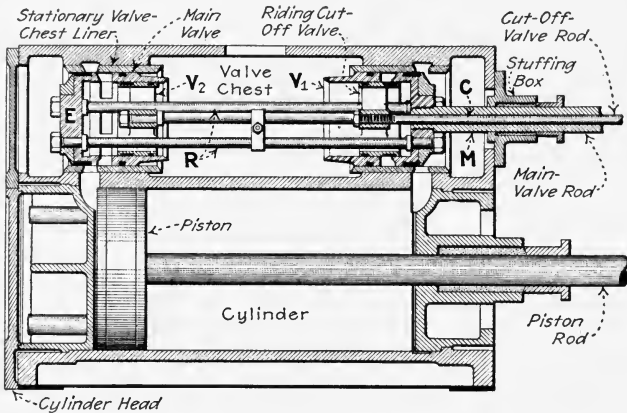

FIG. 185.—Piston-type riding-cut-off valve. (Longitudinal section through cylinder and valve chest of "Buckeye" simple engine.)

Prepare To Set The Valve.—Remove the valve-chest cover. Disconnect the valve rods from the rocker shafts. Remove the valves and place them on a bench. Now, since the valve ports are invisible when the valves are in the valve chest, templets (Sec. 157) must be made whereby the invisible events which occur inside the valve chest will be reproduced outside of it, where the events, thus reproduced, will be visible.

Make The Steam-Port Templet.—First, make a wooden measuring rod (R , Fig. 186); it should be of smoothed clear pine, about 1 in. wide $\frac{7}{8}$ in. thick and somewhat longer than the steam chest. Cut one end to the shape which is shown at the right in Fig. 186. To take the measurements for the steam-port templet, place the shaped end of the rod against the inner steam-port edge as shown. Then, with a knife blade, mark the width of the outer port with two fine lines, X and Y (Fig. 186). Remove the rod from the chest and mark the width of the other steam port on the rod: Measure the width between X and Y and lay off this width from the shaped end of the rod, as shown at Z in Fig. 187. Cut a smoothed clear

pine branch board, *S*, (Fig. 187) for a steam-port templet. It may be $\frac{7}{8}$ in. thick, 4 in. wide and about the length of the valve-chest. Lay the rod on the board and transfer the locations of the ports from the rod to the board, as shown in Fig. 187. Draw pencil "hatch" lines along the length of the board which does not represent the steam ports.

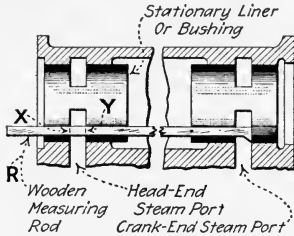

FIG. 186.—Using measuring rod for determining steam-port locations and widths.

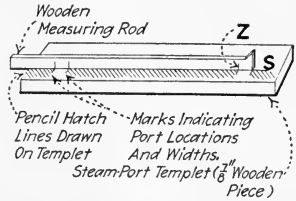

FIG. 187.—Transferring steam-port locations and widths to the steam-port templet.

Make The Main-Valve Templet.—Cut a piece, *M* (Fig. 188), of smoothed clear pine $\frac{7}{8}$ in. by 2 in. and somewhat longer than the main valve. Hold *M* edgewise against the main valve and mark, with knife cuts, the locations of the valve ports and the valve ends, as shown in Fig. 188. Now, if the main-valve templet is placed on the steam-port templet, (Fig. 189) the exact relative positions of the two sets of ports will be shown. The portions of *M* which represent metal should be pencil hatched as suggested in Fig. 189.

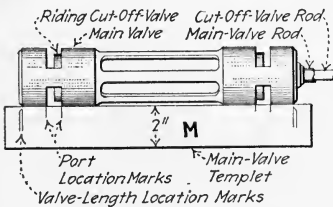

FIG. 188.—Transferring the length of the main valve and the valve-port widths and locations to the main-valve templet.

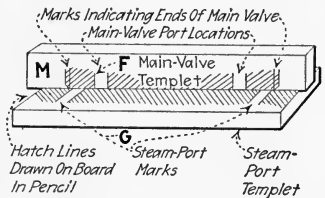

FIG. 189.—Main-valve templet and steam-port templet in correct mid-travel positions showing the relations between the ports in each.

Spot Cut-Off-Valve-Position Marks On The Cut-Off-Valve Rod thus: Slide the cut-off valve inside of the main valve until the left end of the cut-off valve just closes the port, *P* (Fig. 190). Make a trammel gage, *T*, of steel wire. Spot a center-punch mark, *C*, on the main-valve stem. Place one point of *T* in *C* and under the opposite point of *T* spot another center-punch mark, *C'*, on the cut-off-valve stem. Now, slide the cut-off valve to the right within the main valve until the right end of the cut-off

valve just closes the other main-valve port, *Q*. With the punch and gage spot the corresponding mark, *D*, on the cut-off valve stem. Obviously, when one end of the gage, *T*, is in *C* and the cut-off valve is shifted until the other gage end lies in either *D* or *C'*, the corresponding port in the main valve will have just been closed.

Arrange The Templates In Position For Setting The Valve.—Replace both valves in the valve chest. Arrange two saw horses or a bench to support the steam-port templet (Fig. 191) in line with and at the same elevation as the bottom of the valve chest. Place the main-valve templet edge-

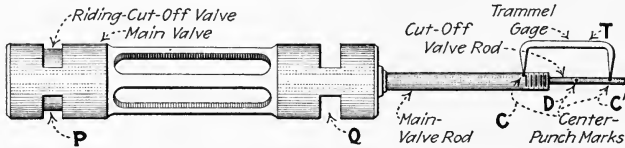

FIG. 190.—Center-punch marks and gage for adjusting the cut-off-valve stem and the cut-off valve.

wise (Fig. 191) on the steam-port templet. Provide a metal strap, *H*, and so fasten it with screws to the main-valve templet that the projecting end of the strap just touches the left end of the main valve, when all are in the positions shown in Fig. 191: That is, have the main-valve eccentric turned to such a position that the left end of the main valve is in line with the head-end steam port edge as shown at *Q* in Fig. 191. Now shift longitudinally the steam-port templet until marks *M* and *N* are in line. Secure the steam-port templet in this position to the bench or horses, with nails driven part way in. The two templets should now accurately represent the relative positions of the main valve and the steam ports

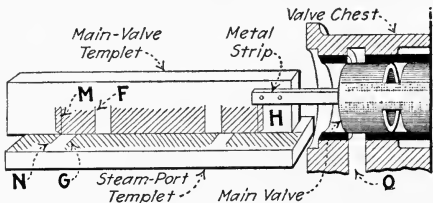

FIG. 191.—Templates arranged at end of valve chest ready for setting the valves.

When the main valve—and the main-valve templet with it—is moved back and forth in its seat the results are reproduced by the templets.

Adjust The Effective Lengths Of The Eccentric Rods So That The Valves, When At The Ends Of Their Travels, Will Open The Head-End And The Crank-End Ports By Equal Amounts.—Since the cut-off valve should be adjusted with reference to the main valve, the main valve should be adjusted first.

Adjust The Main-Valve Eccentric Rod To Correct Effective Length.—Turn the main eccentric to one dead-center position (Fig. 165) and

measure from the templets (Fig. 191) the distance that the edge of the corresponding valve has over-riden the edge of its steam port, or, instead, the distance that the valve should move to entirely open the port. Then, turn the eccentric to the opposite dead-center position (Fig. 163) and note the relative location of the valve edge and port edge in this position. If, in both positions, the valve either opens the ports by the same amount or over-rides the ports by the same amount, the head-end and crank-end travels are equal and the main-eccentric-rod effective length is correct. If this eccentric-rod effective length is not correct, it may be adjusted to correct length as directed in Table 167.

Adjust The Cut-Off-Valve Eccentric Rod To Correct Effective Length; proceed thus: Place the main valve in its mid-travel position (Fig. 189) as indicated by the templets. Secure it in this position by clamping the main-rod stuffing-box gland. Rotate the governor wheel until the cut-off eccentric is on its head-end (Fig. 163) dead center. Then with one point of the gage, *T* (Fig. 190), in center-punch mark, *C*, measure the distance of the other gage point from the punch mark, *C'*, on the cut-off valve stem. Now, retain one point of the gage in *C* and have the cut-off eccentric turned to the crank-end dead-center (Fig. 165) position. Note the distance the gage point is from *D*. If these two distances are equal, the cut-off-eccentric-rod effective length is correct. If it is not of correct length, adjust it to correct length as directed in Table 167.

Set The Main-Valve Eccentric For Selected Equal Leads.—Loosen the stuffing-box gland which clamped the main-valve stem. Turn the engine crank to its head-end dead-center position and rotate the main-valve eccentric to its head-end center position, Fig. 163. [When a *direct valve gear* (one which does not employ levers which change the direction of the valve-stem movement from that of the eccentric-rod movement) and a piston valve is employed, the valve on opening its port for the admission of steam moves in a direction opposite to the direction of motion of the piston. The main-valve gear of the Buckeye engine is "direct."] Therefore if the crank is to run "over" the eccentric should be turned in the opposite direction, or under, until the port at the head end of the cylinder remains open only by the extent of the selected lead. The proper lead may be determined as explained under "Selected Lead" in Sec. 165; it should on engines of this type seldom exceed $\frac{1}{16}$ in. This lead, in any case, is measured as the distance between the lines *F* and *G* in Figs. 189 and 191 on the templets. After it has been thus set for the selected lead, secure the main eccentric to the shaft. The main valve should now be properly set. To check the lead at the opposite end to insure accuracy, turn the engine crank to the opposite dead center and measure the lead which shows with this position. If the lead is not the amount selected and is not the same at both ends, it will be necessary to change the eccentric rod effective length and the angle of advance as directed in Table 167, until the lead is the amount selected and is the same at both ends.

Set The Cut-Off Valve Eccentric.—Turn the engine shaft, starting at the head-end dead center, in the engine's running direction until the main valve, the eccentric of which is now properly secured to the engine shaft, just closes the port in the valve seat. This is the cut-off point for the main valve. Loosen the governor wheel from the engine shaft. Now, starting with the cut-off eccentric—or the governor wheel—at the eccentric's head-end dead center position, turn it in the engine's running direction, until the cut-off valve just closes the port in the main valve. This position is determined by placing one point of *T* (Fig. 190) in *C* and shifting the cut-off eccentric until the mark, *C'*, lies under the other gage-point as shown in Fig. 190. The full part of the cut-off eccentric should now project from the shaft on the same side and in approximately the same direction as does the crank itself. Secure the cut-off eccentric

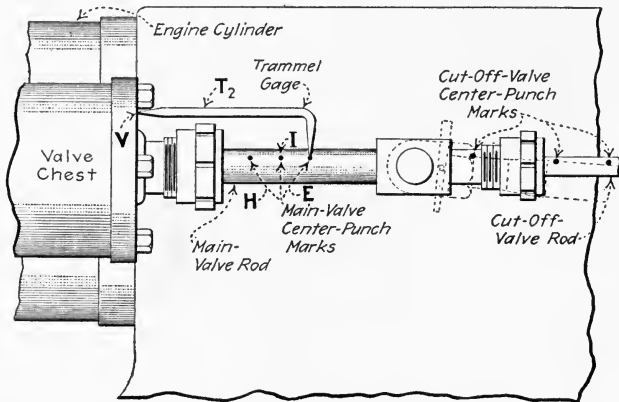

FIG. 192.—Punch marks to insure future rapid setting of the main valve.

(governor wheel), as thus set, to the engine shaft. Both main and cut-off valves should now be properly set.

Spot Identifying Marks On the Main-Valve Stem To Facilitate Its Future Rapid Setting.—Make another trammel gage, as T_2 in Fig. 192. Place the engine crank on dead center again. Spot a center-punch mark, *V*, on the steam-chest head. Place the straight point of T_2 in *V* and spot a center-punch mark, *E*, on the main valve stem under the other point of T_2 . Turn the crank to the opposite dead-center position and spot another center punch mark, under the extending gage point, at *H*. It is evident that, when, at any future time, the main-valve stem is brought into the position shown in Fig. 192 and as determined with T_2 , the main valve will have just opened the port to the extent of the selected lead. Hence, by employing T_2 and the marks *H* and *E*, the main valve may be readjusted without removing it—or even the valve-chest cover. Bisect the distance between *H* and *E* and spot another punch mark at the point of bisection, *I*. Now, if, in the future, *I* is brought under the extending

gage-point, then the main valve will occupy its mid-travel position; this position must be determined in adjusting the cut-off-valve eccentric rod effective length, as before directed. Replace the valve-chest cover and move the engine crank from "dead center" and the job is finished.

Preserve The Trammel Gages.—Drill a small hole through each gage. Tag them respectively "main valve" and "cut-off valve." Tie them together and lay them away in a safe place. The wooden templets, which were employed in setting the valves, need never again be used.

173. To Reverse The Direction Of Rotation Of A Slide-Valve Engine: *For a throttling governed engine*, place the engine in the head-end dead-center position. The lead or lag of the eccentric will then indicate the direction of rotation: *With outside-admission valves* (Sec. 136) the crank pin always, *if there is no eccentric-rod reversing rocker*, follows the eccentric. *With inside-admission valves* (Sec. 136) the eccentric always follows the crank. Loosen the eccentric and turn it about the shaft so that it leads, on lags behind, the crank pin for the new direction of rotation by the same angle as it lagged behind, or led, the crank pin for the old direction of rotation. The lead of the valve will be the same as before. In fact, an often convenient method of reversing the direction of rotation is, the engine being on dead center, to measure the observed lead and then shift the eccentric around the shaft, which will pull over the valve, until exactly the same lead is shown at the same-end steam port. Then secure the eccentric in its new position and the job is completed.

NOTE.—IF A REVERSING ROCKER IS USED IN THE ECCENTRIC GEAR, the eccentric must be placed on the shaft exactly on the opposite side from that which it would occupy if no reversing rocker were employed. That is, with outside-admission valves, the eccentric will follow the crank; with inside-admission valves, the crank will follow the eccentric. With this in mind, the above rules may be followed for reversing the rotational direction of engines with reversing rockers.

174. How Governors Affect Slide-Valve Setting. (1) *Throttling governors* have no bearing on the valve motion and, therefore, need no special attention. Valves on engines having throttling governors have the same motion, irrespective of the engine load. (2) *Variable-cut-off governors*, shaft governors for example, change the motion of the valves with changes in engine-load and, therefore, require consideration when adjust-

ments are being made. These governors may change (a) the valve travel, (b) the angle of advance, (c) both the valve travel and the angle of advance. With such governors the eccentric is almost always fixed to the governor and forms a part of it. It is, therefore, not adjustable on the shaft. The valve-stem length should be adjusted for equality of leads (Sec. 167) or for a slightly larger lead at the crank than at the head end (Sec. 169). If the eccentric must be shifted to obtain satisfactory operation, it is usually necessary to cut a

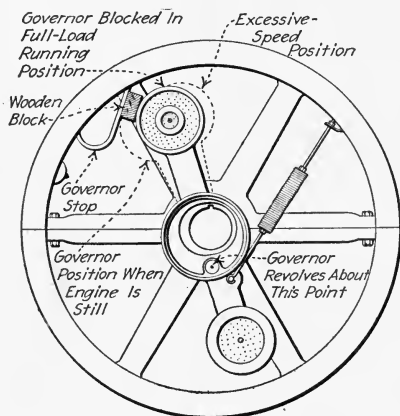

FIG. 193.—Shaft governor blocked in full-load running position for adjusting valve.

new flywheel keyway into the shaft. Whenever adjustment of the eccentric is made, it should be made only when the governor is "blocked" (Fig. 193) into the position which it occupies when running under full load or that fraction of full load at which the engine is most often used. Generally, three-fourths to full load position is used. The valve may then be set by the methods of Sec. 167 to Sec. 169. See also preceding Sec. 164.

NOTE.—TO FIND THE FULL-LOAD RUNNING POSITION OF A SHAFT GOVERNOR, of a type which changes the valve travel, run the engine under a constant full load at the proper speed. Then, with a scale, measure the valve-stem travel. Now stop the engine and so block the governor (Fig. 193) that the same valve travel occurs, when the engine is turned over by hand, as that which occurred when the engine was running.

175. The Steam-Engine Indicator Is Often Used In Valve-Setting Operations (Figs. 194 to 202). See Div. 3 for a preliminary discussion of the application of the indicator in valve setting. The indicator may be used simply to check the setting of valves, which have already been set by measurement, or it may be used to set the valves approximately when it is inconvenient to remove the valve chest cover. There are

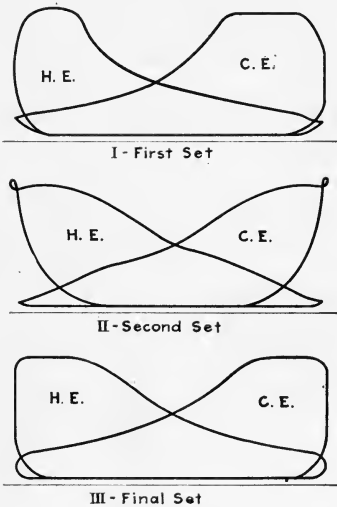

FIG. 194.—Typical successive cards taken from an engine while setting the valves with an indicator.

two fundamental principles which should be observed when using the indicator for valve setting: (1) *The angle of advance, or position of the eccentric with respect to the crank, determines the timing of the events.* (2) *The length of the valve stem, or position of the valve on the valve stem, determines the relative sizes (areas) of the cards from each end of the cylinder with respect to each other.* A valve stem of incorrect length will produce an effect on the crank-end card opposite from that which it produces on the head-end card. In other words, if the crank-end card is found to be increasing in

size with each change of length of the valve stem, it will also be found that the head-end card is correspondingly decreasing in size. Shifting the eccentric, however, will produce the same effects on both the head-end and crank-end diagrams.

EXAMPLE.—The *First Set* of cards, *I* (Fig. 194), taken from an engine which needs valve adjustment, indicate two things: (1) *The head-end and crank-end cards are not the same size; therefore the valve-stem length must be adjusted.* (2) *All events, admission, release, etc., are late, and therefore the eccentric must be shifted on the crank shaft.* Since the head-end card is the smaller, the valve stem should be shortened to allow more steam to flow into the head-end of the cylinder and thus increase the size of the head-end card. Since all events are late it is necessary to increase

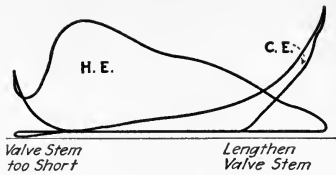

FIG. 195.—Illustrating defective slide-valve setting—valve stem too short (outside-admission valve).

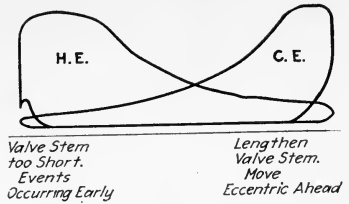

FIG. 196.—Illustrating defective slide-valve setting—valve stem too short. (Outside-admission valve.)

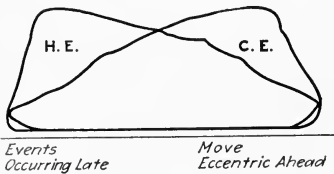

FIG. 197.—Illustrating incorrect angular advance—events occurring late. (Outside-admission valve.)

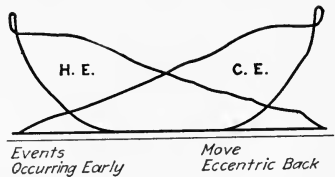

FIG. 198.—Illustrating incorrect angular advance—events occurring early. (Outside-admission valve.)

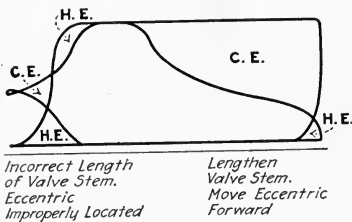

FIG. 199.—Illustrating defective valve setting—valve stem too short and eccentric too far back. (Outside-admission valve.)

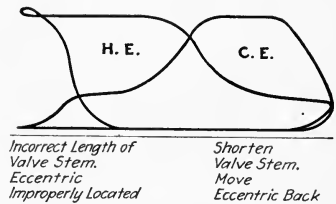

FIG. 200.—Illustrating defective valve setting—valve stem too long and eccentric too far ahead. (Outside-admission valve.)

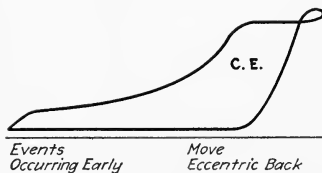

FIG. 201.—Illustrating incorrect angular advance—events occurring early. (Outside-admission valve.)

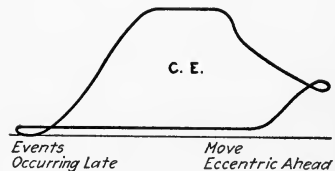

FIG. 202.—Illustrating incorrect angular advance—events occurring late. (Outside-admission valve.)

the angle of advance, or shift the eccentric ahead a trifle to cause the events to come earlier.

The *Second Set* of cards, *II* (Fig. 194), taken after the above adjustments have been made, show that the length of valve-stem is now correct but that the eccentric has been shifted too far ahead and that all events are occurring too early. The eccentric should therefore be shifted backward about half the amount by which it was originally shifted forward.

The *Final Set* of cards, *III* (Fig. 194), indicate that the valve is now functioning properly and that further adjustments are unnecessary.

176. Various Defects Of Slide-Valve Settings, As Determined By The Steam Engine Indicator, And Their Remedies are shown in Figs. 195 to 202. See also Sec. 112 in Div. 3 for further information relating to this subject. Much time will be saved if each set of cards which is taken is studied very carefully before resetting the valve. It sometimes happens that successive cards will show only slight changes in the valve setting. It should also be noted that the various changes recommended to correct the defective valve settings in Figs. 195 to 202 are only for outside-admission slide valves. If inside-admission slide valves are to be considered, adjustments different from those recommended in these illustrations should be made; see note following Table 159.

QUESTIONS ON DIVISION 4

1. What are the outstanding features of slide valves? On what classes of engines are they used?
2. What is meant by *valve setting*?
3. What are *valve diagrams* and what is their use?
4. Enumerate the functions of a slide valve?
5. What are the positions of the valve on its seat and of the piston in the cylinder at admission, cut-off, release, and compression for each end of the cylinder? Draw a sketch for each position.
6. Explain, with a sketch, *outside-admission* and *inside-admission* slide valves.
7. Enumerate the advantages and disadvantages of plain D-slide valves.
8. What are the advantages and disadvantages of piston slide valves.
9. Do inside-admission valves have any advantage over outside-admission valves?
10. Draw a sketch to explain the principle of balancing a flat slide valve. What is the purpose?
11. Summarize the advantages and disadvantages of balanced slide-valves.
12. Discuss the merits of multiporting a valve. Are multiported valves balanced?
13. Explain the principle and purpose of the riding-cut-off valve. Give its advantages and disadvantages.
14. Define valve *lap*. Draw sketches to differentiate between steam, exhaust, inside and outside lap.
15. With inside-admission valves, what other name can be given to the outside lap? To the inside lap?

16. What is meant by *inside clearance*? What class of slide valves may have inside clearance? What does it accomplish?
17. Should valve lap ever be changed? If so, when and how?
18. What are the purposes of fitting a valve with lap?
19. Draw a sketch to define *lead*. Explain fully its purpose.
20. What is the usual operating mechanism for a slide valve?
21. Explain the similarity of an eccentric to a crank. Is there any difference?
22. Define *eccentricity*, *eccentric circle*, *throw*, *valve travel*.
23. What is the usual relation of valve travel to eccentricity?
24. Define the *angle of advance*. Upon what does it depend?
25. Explain the relative positions on the shafts of eccentrics for inside- and outside-admission valves.
26. With a sketch, illustrate connecting-rod *angularity*. How does it affect (1) the piston velocity, (2) the valve events?
27. Discuss angularity of the eccentric rod.
28. Define *dead center* and tell why, in valve-setting, it must be accurately established. Give the usual method of establishing dead centers.
29. How can one compensate for lost motion in establishing dead centers?
30. What are the two general methods of setting steam-engine valves? What are the advantages and limitations of each?
31. Draw a sketch and with it explain the *indirect-measurement* method of ascertaining valve operation.
32. Explain the use of *templers* in valve setting.
33. With sketches describe how an eccentric can be placed exactly on "center."
34. What are the possible adjustments of a slide-valve operating mechanism?
35. How should the valve be set on a new engine? On an old engine?
36. For what three operating conditions may slide valves be set? What are the advantages of each condition?
37. How could you proceed in setting a slide valve for equal leads?
38. Give the principal steps in setting a valve for equal cut-offs. Is this a direct procedure? Has it any limitations?
39. What is the reason for sometimes setting a slide valve for unequal leads and how is it done?
40. Does setting for unequal leads provide an ideal indicator diagram? Why?
41. Does the setting of multiported valves involve any more operations than that of single-ported valves? Why?
42. How would you set the main valve of a riding-cut-off engine?
43. Tell how to set the riding-cut-off valve of an engine on which a hand-wheel adjustment exists. How far ahead of the crank should the eccentric be placed?
44. What is the procedure in setting a riding-cut-off valve which is controlled by a shaft governor?
45. How is the riding-cut-off valve set when it is neither hand-adjustable nor governor-operated?
46. Does a shaft governor affect the procedure in valve setting? Why?
47. Is it generally possible to set a shaft-governed engine for any desired condition? Why?
48. How do throttling governors affect valve setting?
49. How may one find the full-load running position of a shaft governor?
50. How do the angle of advance and effective length of valve stem, if incorrect, distort an indicator diagram?
51. What would be the procedure in rectifying the diagrams shown in Fig. 101?
52. Describe the valves and valve-operating mechanism of the McIntosh & Seymour engine.

DIVISION 5

CORLISS AND POPPET VALVES AND THEIR SETTING

177. The Reasons For Employing Corliss Or Poppet Valves are: (1) *These valves are suited to engines which require small clearances*, Sec. 305; these valves can be located very near to the place where steam enters or leaves the cylinder and usually have but a very limited movement. (2) *They are well adapted where a quick opening and closing of the valves is necessary*—especially where a quick closing of the valve at cut-off is essential. (3) *By reason of their limited movement, these valves are subjected to little friction*; the mechanical losses (Sec. 11) of such engines are, therefore, small and the valves will operate a long time without showing signs of wear.

NOTE.—ENGINES WITH CORLISS AND POPPET VALVES ARE USUALLY MUCH MORE EFFICIENT (see Div. 10) than are engines with slide valves, but to provide the increased efficiency the engines must have a greater number of parts and cost much more to construct. They are therefore used chiefly when the saving due to their efficiency more than offsets their high initial cost.

178. The Advantages Of Corliss Valves (see Div. 2 for definition) are: (1) *The valves may be made to move slowly and but little when they are opened or closed*. (2) *The valves move rapidly while opening or closing*, especially where detaching valves are used. (3) *The valves may be located very near to where the steam is to be admitted to or exhausted from the cylinder*. (4) *The valve events—admission, cut-off, release, and compression—are independently adjustable*, and only cut-off need be varied to meet the requirements of different engine loads. (5) *Steam is exhausted from the cylinder through separate valves from those through which the steam is admitted*. Thus, the cooler exhaust steam does not sweep over and cool the admission valves; see Sec. 274.

179. Typical Designs Of Corliss Valves are shown in Figs. 203 to 206, and 233. Features which distinguish good design may be enumerated thus: (1) *The valves should never extend*

into the displacement volume; that is, there should be no danger, even if the valve were stopped in any position, of the piston striking it and causing damage. (2) The valves should, in all positions, be supported on the seat throughout their entire length; that is, there should be no tendency for the steam acting on one side of the valve

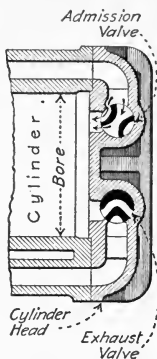

FIG. 203.—Corliss valves (positively-operated) in cylinder head of the "Ideal" Corliss-valve engine.

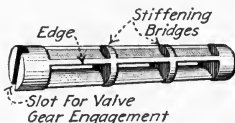

FIG. 204.—Corliss admission valve of the "Ideal" Corliss-valve engine.

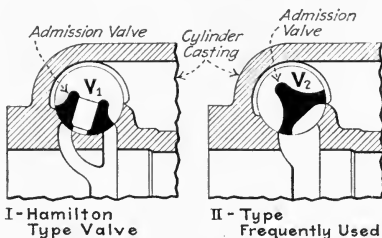

FIG. 205.—Detaching Corliss-engine admission valves (Hooven, Owens, Rentschler Company. Valve V_1 is supported its full length at all times. Valve V_2 , when open, is supported only at its ends or by the bridges which may cause it to spring. V_1 weighs somewhat less than V_2 . The cylinder clearance is somewhat less with V_1 than with V_2 .)

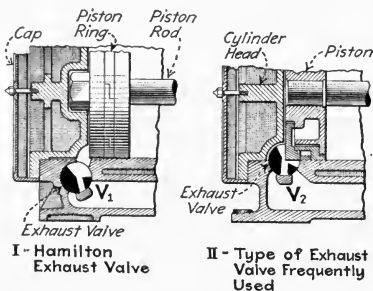

FIG. 206.—Detaching Corliss-engine exhaust valves. (Hooven, Owens, Rentschler Co. In the Hamilton construction, V_1 , the valve does not rock into the cylinder space, where, should the valve gear break, it might wreck the engine.)

to bend it and thus possibly cause uneven wear of its seat.

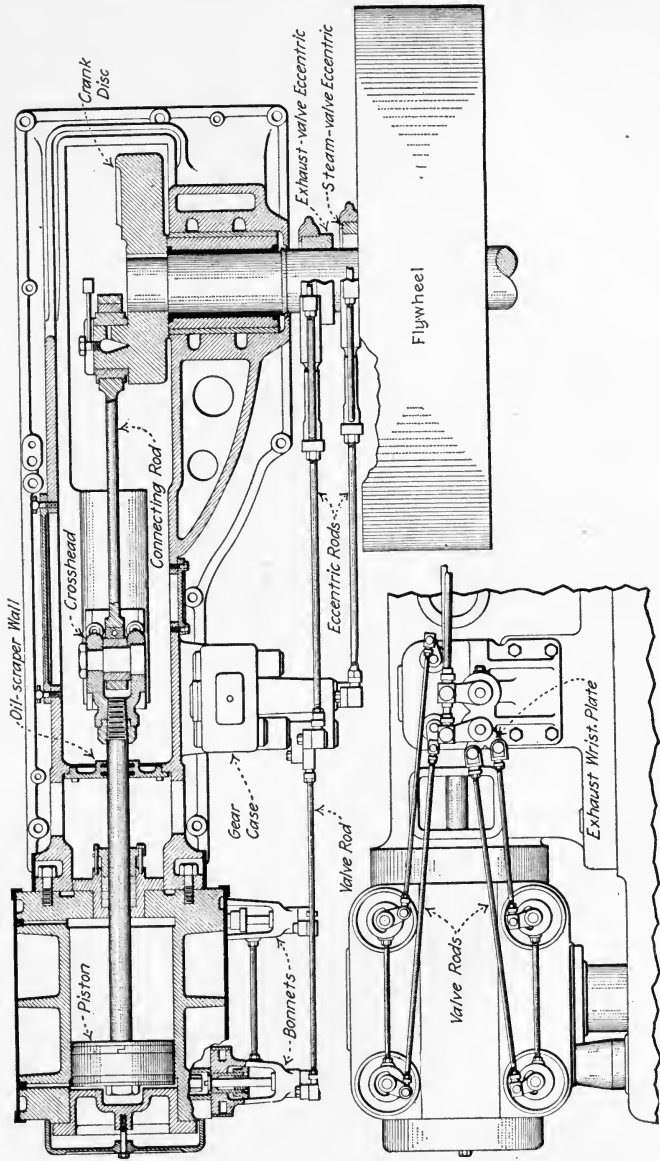

FIG. 207.—Plan and partial side view of Ridgway four-valve engine showing valve-operating mechanism.

(3) With multiported valves, the number of edges past which leakage might occur should be a minimum. (4) The total projected area against which steam may act to force the valve against its seat should be a minimum, so as to reduce the force causing friction at the valve.

180. Positively-Operated Corliss-Valve Mechanisms are illustrated in Figs. 38, 207, 208, 209, and 235. The admission valves in these mechanisms are usually operated through a wrist plate (Fig. 38) or through a system of separate levers and links for each valve.—these levers may be located at the valve

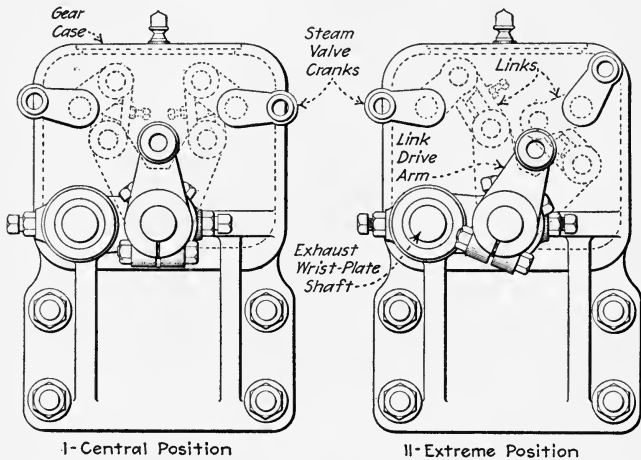

FIG. 208.—Showing linkwork inside of gear case of Ridgway four-valve engine.

(Fig. 209) or alongside the crosshead guides (Fig. 207), and they may be enclosed in a dust-proof case or they may be exposed. The valves may, however, be driven by rods attached directly to a rocker arm as are the exhaust valves in Fig. 209. The exhaust valves are usually driven from a separate wrist plate or directly from a rocker arm, although they are sometimes driven by a system of levers and links such as that shown for the admission valves in Fig. 209.

181. The Advantages And Disadvantages Of Positively-Operated Corliss-Valve Engines are, in general, those stated in Sec. 178. The following additions should be noted: (1) Being positively-operated, *the valves may be operated at higher*

speeds than can the detaching Corliss valves. This means that, with a given size of cylinder, a positively-operated-valve engine may operate at a higher speed and hence can develop more power and can operate satisfactorily with a smaller flywheel than can an engine which has detaching valves. (2) *The operation of the valves is practically noiseless.* Detaching Corliss engines make considerable noise as the dash pots close. (3) *Shaft governors are more applicable to positively-*

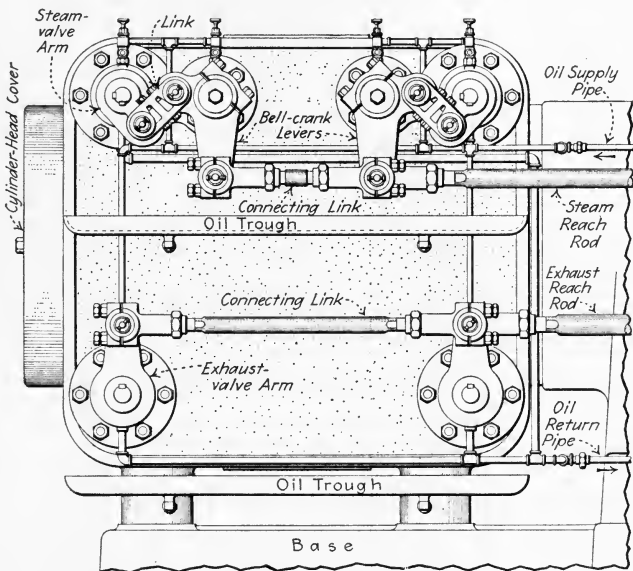

FIG. 209.—Valve gear of Ames four-valve non-releasing Corliss engines. (Ames Iron Works.)

operated than to detaching valves. This means that the speed regulation will, generally speaking, be better with positively-operated valves. (4) For long-stroke, slow-speed engines especially, *positively-operated valves do not give as quick cut-off as do the detaching valves.* It follows from the above that positively-operated Corliss valves are best suited for short-stroke, medium- and high-speed engines where close regulation of speed is desired. They provide a relatively compact, efficient, and noiseless type of engine for this service.

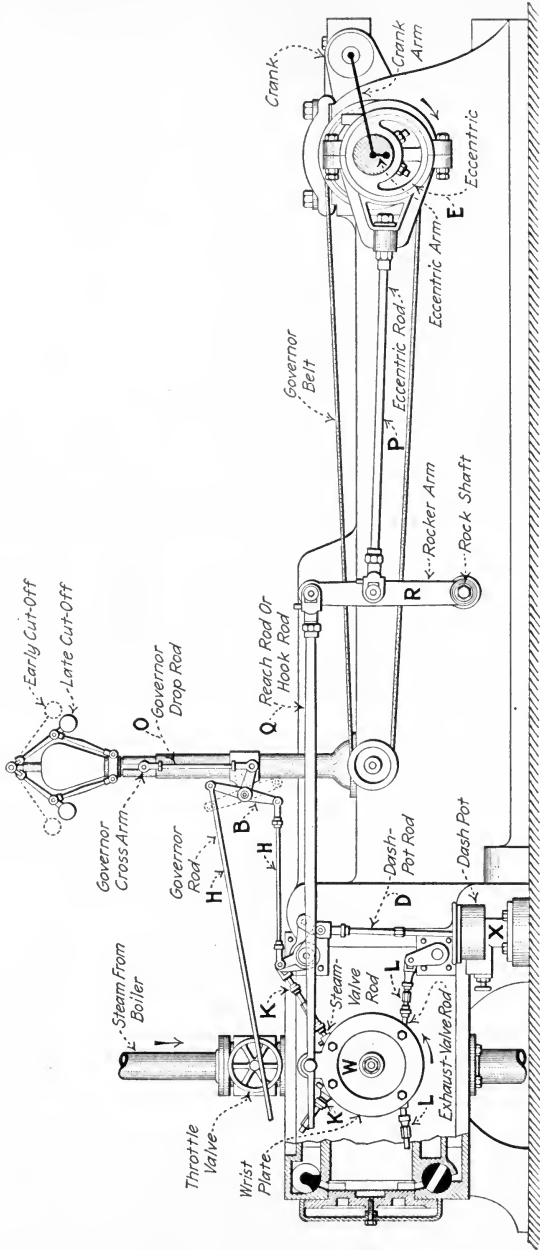

FIG. 210.—General assembly of detaching Corliss valve gear.

182. Detaching (Releasing, Or Drop-Cut-Off) Corliss-Valve Mechanisms (see Sec. 50 for definition) are illustrated in Figs. 210 to 212. The valve stem, *S*, Fig. 211, is extended from the cylinder through a bracket or *bonnet* and has keyed to it the *steam-valve arm* (*D*, Fig. 212). The hub of the steam-

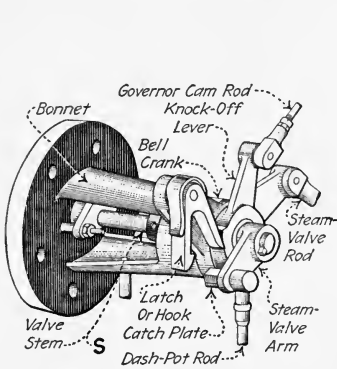

FIG. 211.—Part-side view of typical Corliss-valve releasing mechanism.

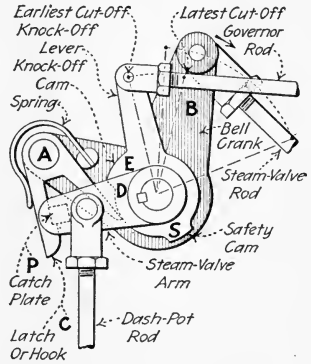

FIG. 212.—Front view of typical Corliss-valve releasing mechanism.

valve arm forms a shaft upon which a bell crank, *B*, Fig. 212, and a *knock-off lever*, *E*, are mounted so as to turn freely. *B* is connected at one end to the steam-valve rod (*K*, Fig. 210); and carries at its other end a latch or hook (*C*, Fig. 212) which is pivoted at *A*. The steam-valve arm, *D*, has, attached to it,

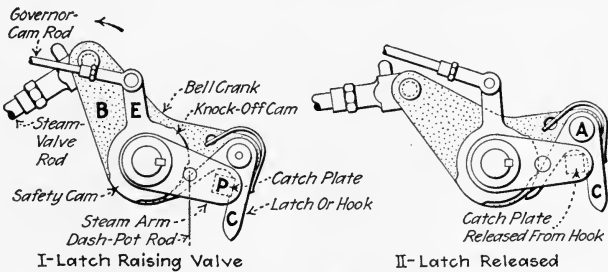

FIG. 213.—The Reynolds trip gear for Corliss engines.

a *dash-pot rod* (*D*, Fig. 210) which leads to a dash pot, *X*. The operation of this *releasing mechanism* or *trip gear* is explained below:

EXPLANATION.—Suppose the bell crank to be turned, by the steam-valve rod, in the direction indicated in Figs. 212 and 213. The latch, *C*,

engages a projection or *catch plate*, *P*, on the steam-valve arm, *D*, and raises *D*, rotating it about its axis and opening the valve. The dash-pot rod is also raised, forming a partial vacuum in the dash pot. Arms *B* and *D* thus turn together as one, until the inner arm of the latch strikes the knock-off cam on the lever, *E*, which remains stationary. When the latch arm does strike the knock-off cam—lever *B* still moving as indicated—the latch is rotated about its pivot at *A* and the catch plate on *D* is released from the hook, *C*. The air pressure above the dash-pot piston immediately forces it down, drawing arm *D* with it and closing the valve.

183. Advantages And Disadvantages Of Detaching-Corliss-Valve Engines are, generally, as given in Sec. 178, and in addition, the following: (1) *Cut-off occurs very rapidly irrespective of the engine speed or load.* This makes these valves satisfactory for slow-speed, long-stroke engines, of which class all very large engines necessarily must be. (2) *The valves cannot be operated at high speed* because, at high speeds, the valves tend to act sluggishly and sometimes do not open. (3) *The valve mechanism is noisy* as compared to that of positively-operated Corliss valves. From the above it is evident that the detaching-Corliss-valve mechanism is particularly and well suited to large low-speed, long-stroke engines.

184. The Elements Of A Detaching-Corliss-Valve Mechanism are, besides the releasing or trip gear described in Sec. 182, the following: (1) *An eccentric, E*, Fig. 210, for imparting motion to the valve gear. (2) *A wrist plate, W*, which receives the motion of the eccentric and imparts it to (3) *the valve rods, K and L*, which in turn move the bell cranks, *B*, Fig. 212, and the exhaust-valve arms. Since the distance from the eccentric to the wrist plate is long, the connection between them is made up of (4) *an eccentric rod, P*, Fig. 210, and (5) *a reach rod, Q*, both supported on a (6) *rocker arm, R*, which relieves the wrist plate and eccentric of considerable weight. The knock-off levers, *E*, Fig. 212, are held in place by (7) *governor rods, H*, Fig. 210, which are controlled through a bell-crank lever, *B*, by the (8) *governor drop rod, O*. (9) *The dash pot rod, D*, Fig. 210, connects the steam valve arm, *D*, Fig. 212, with the (10) *dash pot piston* in *X*, Fig. 210.

NOTE.—DETACHING-CORLISS-VALVE ENGINES FREQUENTLY HAVE TWO ECCENTRICS and then, of course, they also have two eccentric rods,

two rocker arms, two reach rods, and (usually) two wrist plates. The reason for using two eccentrics is explained in Sec. 185. Furthermore, engines of certain makes depart somewhat from the exact mechanism described above but these are special constructions which are so designed for some specific purpose and usually differ very little from that here described.

185. The Features Of Single- And Double-Eccentric Detaching-Corliss-Valve Mechanisms are: (1) *When a single eccentric drives both the steam and the exhaust valves, the range of cut-off is limited to about one-third the piston stroke.* The reason for this is explained below. (2) *In order to obtain a greater range of cut-off, separate eccentrics are employed, one to drive the exhaust valves, the other to drive the steam valves.* With two eccentrics, the admission and exhaust valves can be adjusted independently, and steam may be cut off anywhere, nearly to the end of the stroke.

EXPLANATION.—WHY, WITH A SINGLE ECCENTRIC, THE CUT-OFF RANGE IS LIMITED TO ABOUT ONE-THIRD STROKE may be explained thus: After an eccentric, in rotating, reaches the extreme of its throw or its "center" position (Sec. 154), all of the motions which it compels are reversed. Now, in a Corliss trip gear, the catch plate is released—if released at all—while the wrist plate pulls on the bell crank. Also, the wrist plate ceases to pull on a bell crank when its direction of rotation is reversed; that is, when the eccentric from which the wrist plate derives its motion reaches its center position. Therefore, the catch plate is released—if released at all—before the eccentric reaches the extreme of its throw. Now, considering the eccentric motion with reference to the exhaust valves, which it also operates through the wrist plate—it is evident that each exhaust valve has its greatest opening when the wrist plate, and hence the eccentric, is in its extreme position. It is also evident that the exhaust valve opens and closes at equal time intervals before and after it has its greatest opening. Therefore, since release must occur before the end of a forward stroke and since compression (exhaust valve closure) must occur before the end of a return stroke, it is evident that the greatest opening of the exhaust valve, and hence the extreme throw of the eccentric, must occur before the middle of the return stroke. It follows, then, that the eccentric must occupy its other extreme position before the middle of the forward stroke. Now, since the steam valves—if released at all—must be released before the eccentric reaches its extreme position, it follows that they must be released before one-half stroke is completed.

It follows from the above that, to obtain as large a cut-off range as possible with a single-eccentric mechanism, both release and exhaust valve

closure must occur late. These conditions might be satisfactory for a very slow rotative speed; but, for higher speed, earlier release and more compression would surely be required. These latter conditions can only be obtained by moving the eccentric forward on the shaft, and this in turn cuts down the cut-off range. The practical cut-off range with a single-eccentric Corliss-valve mechanism is therefore about one-third stroke.

186. Typical Designs Of Corliss-Valve Detaching Mechanisms Or Trip Gears are shown in Figs. 211, 212, and 214 to

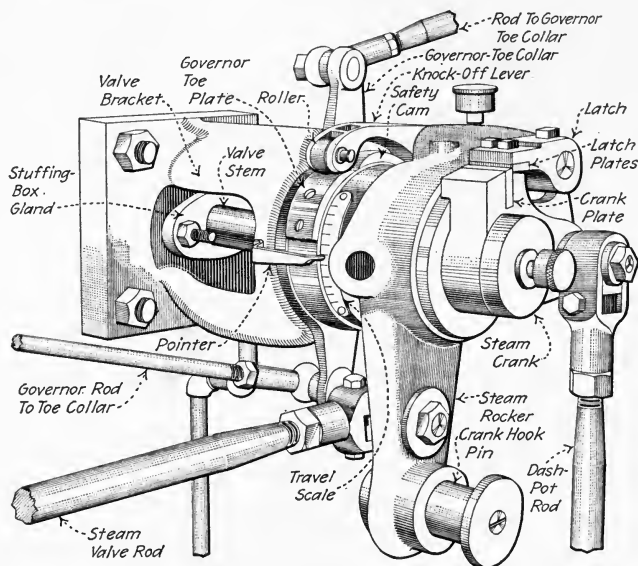

FIG. 214.—Gravity trip gear of Hamilton Corliss engines.

221. The *Reynolds trip gear*, as shown in Figs. 211, 212 and 220, is probably the oldest design and most widely used. It relies upon a spring to cause engagement of the hook and catch plate. Because springs sometimes break, some manufacturers have designed trip gears in which engagement is effected by gravity (Figs. 214 and 219). Other manufacturers employ positive knock-off cams (Figs. 215 and 216) which have an added advantage of being adapted to somewhat faster operation than either spring- or gravity-opposed cams.

187. Dash Pots For Detaching Corliss Valves (Fig. 222) are constructed differently by almost every manufacturer. The

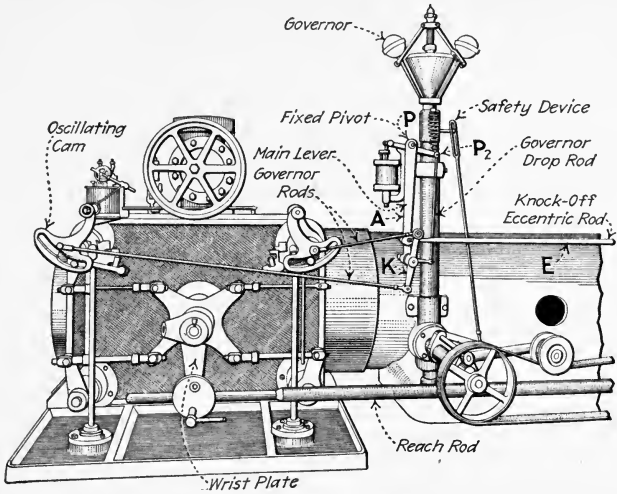

FIG. 215.—Nordberg long-range valve gear and governor. (The main lever, *A*, is supported by a bracket on the governor at point *P* about which it is caused to swing by the knock-off eccentric rod, *E*. At the bottom end of this lever is hung the three-armed lever, *K*, the two vertical ends of which are connected to the knock-off cams and the horizontal arm is connected by the drop rod to the governor at point *P*₂. The drop rod is parallel to *A*. It is obvious that since this parallelogram is oscillated by the knock-off eccentric drive rod, its sides must remain parallel; therefore, the lever, *K*, always moves in a position parallel to itself. Should, however, a change of load occur, the governor then lifts or lowers the point, *P*₂, thus changing the angularity of lever *K* and changing the center of oscillation of the cams and the point of cut-off.)

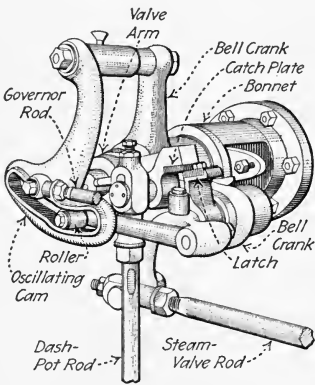

FIG. 216.—Patent long range Corliss trip gear. (Nordberg Mfg. Co.)

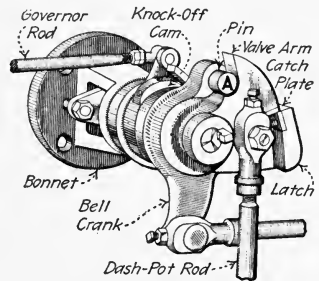

FIG. 217.—Corliss-valve trip gear as used on Vilter engines. (Vilter Mfg. Co.)

primary function of the dash pot is, of course, to provide a means for quickly closing the admission or steam valve when the catch plate is released from the hook. A dash pot which was designed to produce only this effect might, however, cause much noise when the plunger struck the bottom of the cylinder. To overcome this objectionable feature, dash pots are usually equipped with a secondary piston which must force air from a cylinder as it descends. By properly restrict-

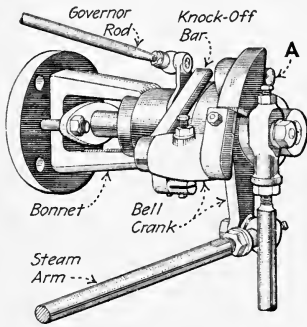

FIG. 218.—Vilter Corliss-engine trip gear showing knock-off bar.

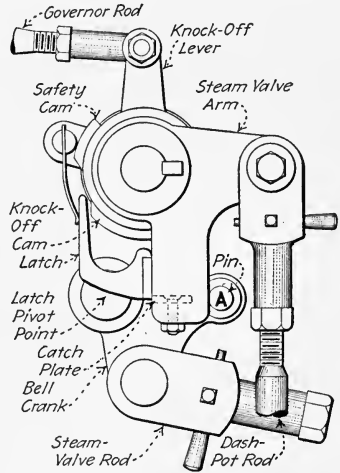

FIG. 219.—Gravity trip gear of Murray Corliss engines. (Murray Iron Works Co.)

ing the opening through which the air is expelled, a very effective cushion can thus be provided.

EXPLANATION.—As explained in Sec. 182, when the dash pot is lifted through rod, *R* (Fig. 222), a partial vacuum is created beneath the piston, *P*. Also, air is drawn in through the hole, *H*, into the lower portion of cylinder *C*. When the dash-pot rod is released, the air pressure from above forces down the plunger, which must now displace the entrapped air from *C*. The passage of air from *C* is restricted by the valve, *V*, which can so be adjusted as to produce in *C* the desired cushioning.

NOTE.—THE TRIP GEAR SHOULD PROVIDE A MEANS FOR CLOSING THE STEAM VALVE IF THE DASH POT DOES NOT FUNCTION. With the Reynolds gear, the inside of the hook *C*, Fig. 213, accomplishes this result by forcing down the dash-pot rod. With the mechanisms of Figs. 217 and 219, the steam valve is positively closed by the pin *A*.

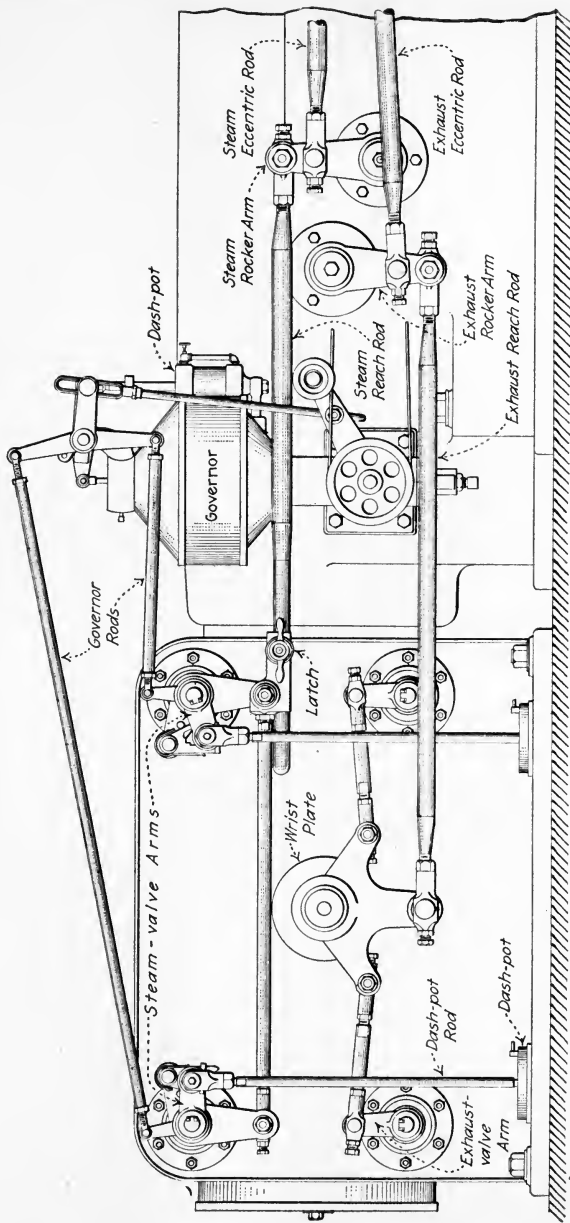

Fig. 220.—Standard valve gear of Allis-Chalmers heavy-duty Corliss engines. (Note that steam valves are not driven from a wrist plate and that exhaust-valve wrist plate is driven from a point below its supporting pin.)

188. The Advantages And Disadvantages Of Poppet Valves (see Sec. 51 for definition) are: (1) *They are very well suited to use with superheated steam*; because they are small and very symmetrical in form, they are not distorted by temperature changes. (2) *A large valve opening is effected with only a small valve movement*; thus, little work is required to move the valve in opening it. (3) *The valve does not slide on its seat, but lifts from the seat*; thus, there is no wear between the two and the valve is not likely to leak. (4) *The clearance can be small as with Corliss valves*; thus, clearance losses are kept small. (5)

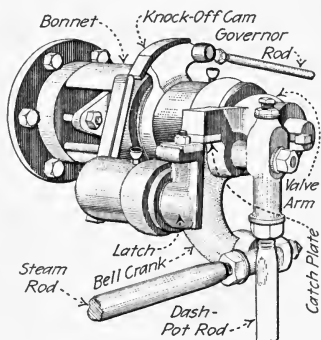

FIG. 221.— Nordberg standard Corliss valve gear.

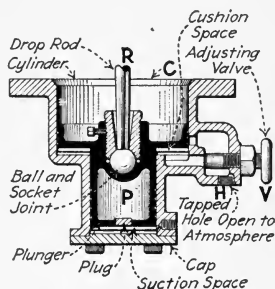

FIG. 222.— Corliss-valve dash pot. (Murray Iron Works, Burlington, Iowa.)

Poppet-valve operating mechanisms are usually complex; being more complicated than the mechanisms for any other type of valve, they are usually also more expensive. The use of poppet valves in steam engines is comparatively recent practice. Many new forms of valve-operating mechanisms are being made but whether all of these mechanisms are mechanically good remains yet to be seen. (6) *Poppet valves are nearly balanced* because they expose only a small unbalanced area to steam pressure; they are, thus, easily lifted from their seats. The slight unbalance is really desirable as the steam pressure holds the valves against their seats and thus prevents leakage. The use of poppet valves is certain to continue, however, and increase as time goes on and as facilities for the production of superheated steam improve.

NOTE.—POPPET VALVES SHOULD BE SO LOCATED IN THE ENGINE CYLINDER THAT WATER CANNOT STAND ON THEIR SEATS when the engine is not running. If water is permitted to collect on the valve seats, it soon corrodes them and causes leakage. The slightest leak affords a place for steam to blow through and wear a larger leak.

189. Single And Double-Beat Poppet Valves (Figs. 40 and 41) are, respectively, those (Fig. 40) which are solid and close

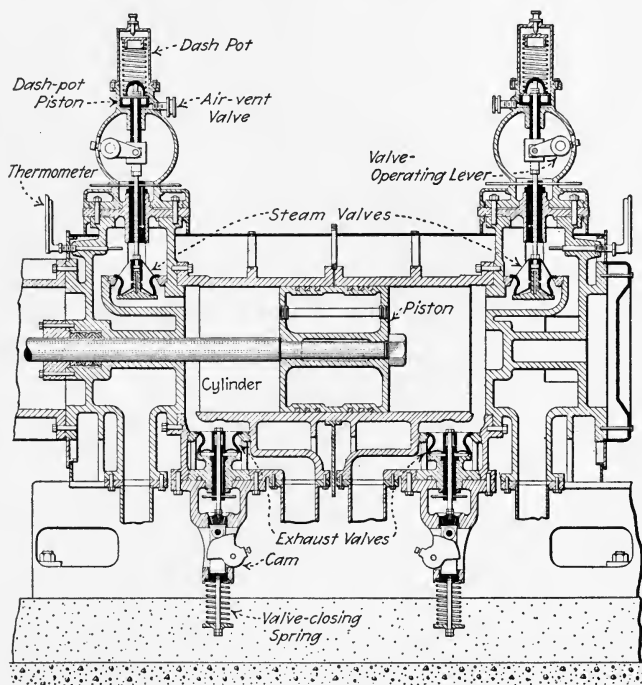

FIG. 223.—Longitudinal section through cylinder of Vilter poppet-valve engine. (Vilter Mfg. Co.)

against one ring or a seat, and those (Fig. 41) which are made hollow and close against two rings or seats, one above the other. Single-beat poppet valves are analogous to simple slide valves in that they are forced against their seats by the difference of the pressures above and below the valve, and in that when open they offer but one passage through which the steam can flow: Double-beat poppet valves are analogous

to balanced, double-ported slide valves in that the difference of the pressures above and below the valve acts only on a portion of the valve's projected cross-sectional area, and in that, when open, the steam may flow under the outer edge and through the hollow center of the valve.

190. Typical Designs Of Poppet-Valve Mechanisms are illustrated in Figs. 41, 42, 223 to 227, and 242. In general, it may be stated that the poppet valve is given its motion by an oscillating cam (Figs. 41, 42, 224 and 246) or a reciprocating

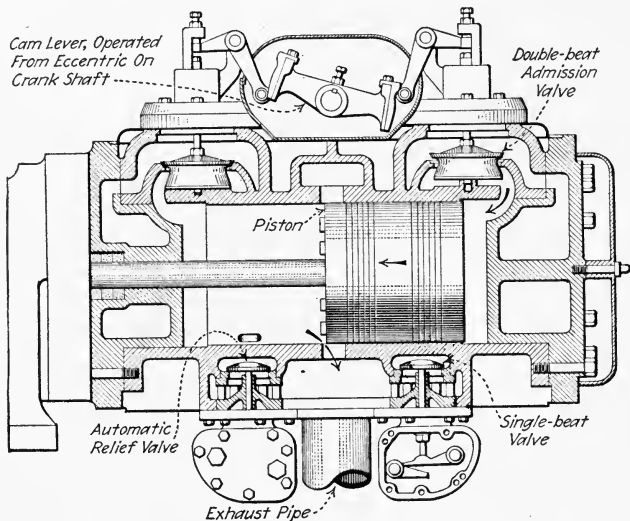

FIG. 224.—Longitudinal section through cylinder of Skinner "Universal Una-flow" engine, showing valve-operating mechanisms.

cam (Figs. 227 and 242) which in turn derives its motion from an eccentric. The eccentric may be on the main or crank shaft of the engine or it may be on a lay-shaft which lies alongside of and parallel to the longitudinal axis of the cylinder and which derives its motion through miter or helical gears from the crank shaft. The cam which operates the valve may be a positive one—that is, it may compel the closure as well as the opening of the valve—or it may simply open the valve against a spring which later closes the valve. The spring, if one is used, should be located where the high-

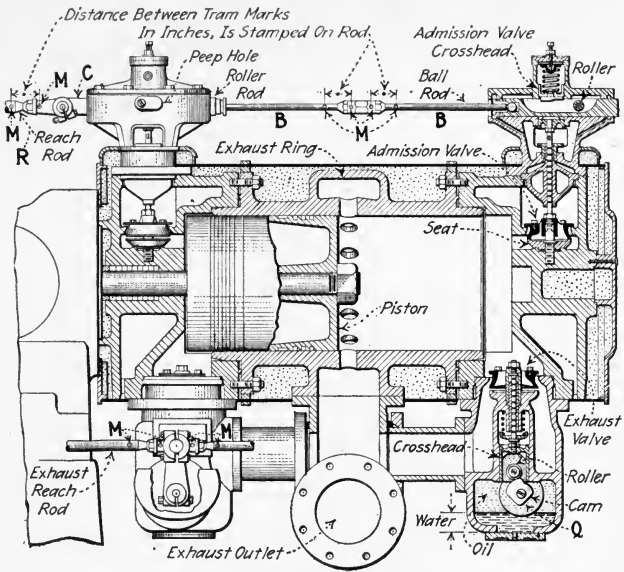

FIG. 225.—Longitudinal section through cylinder of "Ames controlled-compression una-flow" engine.

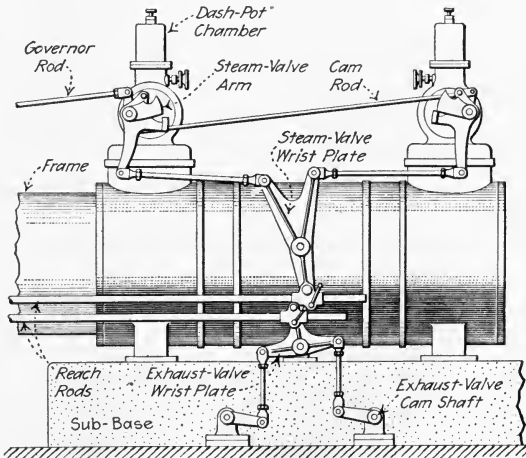

FIG. 226.—Poppet-valve operating mechanism of Vilter engines. (Note that this engine employs the usual double-eccentric Corliss-valve trip gear for operating the poppet valves.)

temperature steam will not flow over it and thereby heat it. A spring which is subjected to high temperature is apt to rapidly lose its temper.

191. In Setting The Valves Of A Corliss- Or Poppet-Valve Engine, the first thing to do is, if possible, to get the manufacturer's instructions and recommendations as to the lap and lead. If this information cannot be obtained, the valve-setting may be done as directed in the following sections. Good values of steam lap, exhaust lap, and steam lead for Corliss engines are given in Table 193.

192. The Directions For Setting Valves Of Single-Eccentric Detaching-Corliss-Valve Engines are:

1. ESTABLISH MARKS, if this was not previously done. The necessary marks are: (a) Three marks—*C*, *B*, and *D*, Fig. 228—on the wrist-plate support, to denote the central and extreme positions of the wrist plate. (b) A mark, *A*, on the wrist-plate hub, which is used with *B*, *C* and *D*. (c) A mark or marks (*S*, Fig. 229) on the end of each steam and exhaust valve—the mark to denote the position of the valve's working or cutting edge. (d) A mark or marks (*T*, Fig. 229) at the end of each valve seat—to indicate the position of the working edge of the seat.

The mark *A* (Fig. 228) is made at any convenient point on the wrist-plate hub, usually on the top as shown. Then, with the wrist plate in its vertical position (Fig. 230)—that is, with the reach-rod pin directly in vertical line with the center of the wrist plate—mark *B* is located on the support opposite *A* which is on the wrist plate, as shown in Fig. 228. Marks *C* and *D* are located later as described under (4). To make marks *S* and *T*, remove the back bonnets (the plates over the valve openings on the opposite side of the cylinder from the wrist plate). Remove the valves successively from their seats and with a straight-edge along the working edges (Fig. 231) scribe marks at the ends. These marks can then be cut lightly with a cold chisel as shown in Fig. 229.

2. ADJUST THE LENGTHS OF THE STEAM AND EXHAUST VALVE RODS

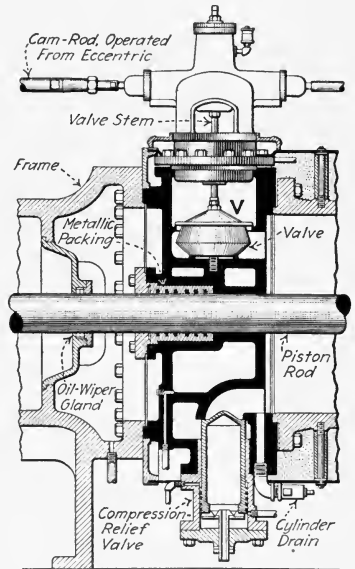

FIG. 227.—Detail of poppet-valve mechanism on head end of Chuse uniflow engine.

(*K* and *L*, Figs. 210 and 232). To do this, unhook the reach rod, *Q*, from the wrist plate and set the wrist plate in its central position, that is, with mark *A* opposite mark *B*, Fig. 228. Clamp the wrist plate in this position by placing a sheet of paper between it and the washer, *L* (Fig. 228), and tightening the retaining nut. Remove the back bonnets, as above directed, if this was not previously done. Now adjust the lengths of the

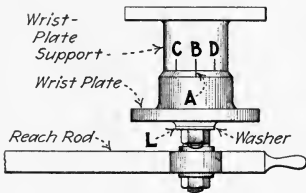

FIG. 228.—Plan view of Corliss wrist plate showing marks used in setting valves.

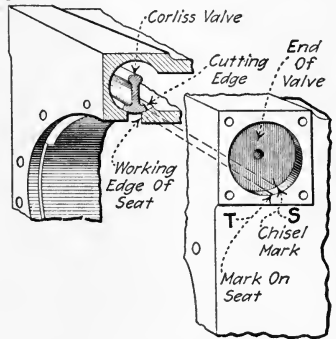

FIG. 229.—Showing marks on Corliss valve and seat whereby the relation of the cutting edges can be judged.

steam valve rods, *K*, so that the valves have a little lap as shown on Fig. 233. These rods are nearly always made with right and left-hand threads at opposite ends to facilitate adjustment. The lap, measured between *S* and *T* (Fig. 233), will range from $\frac{1}{16}$ to $\frac{1}{4}$ in. for small engines and from $\frac{1}{4}$ to $\frac{3}{8}$ in. for larger engines; see also Table 193. Then adjust

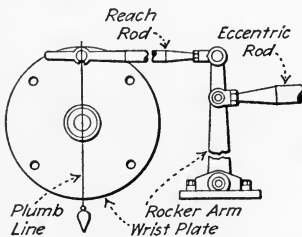

FIG. 230.—Plumbing wrist plate and rocker arm.

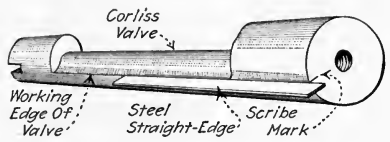

FIG. 231.—Showing method of making mark on end of a Corliss valve.

the lengths of the exhaust valve rods, *L*, Figs. 210 and 232, so that the valves will just coincide, or—in other words—so that the marks *E* and *F*, Fig. 233, are in line with each other. Some engineers prefer a slight amount of lap at the exhaust ports (see Table 193), others prefer a slight opening of the exhaust ports when the wrist plate is central; under these conditions the marks *E* and *F* cannot be in line. The distance between

these lines will be equal to the desired amount of opening or lap. For small engines the opening of the exhaust valves may be $\frac{1}{16}$ in. and for

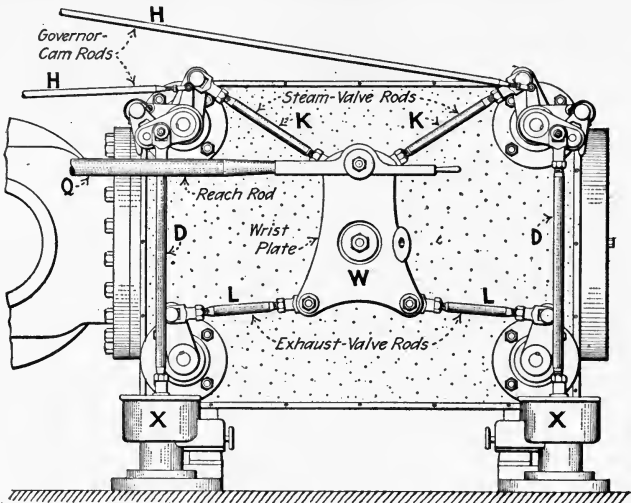

FIG. 232.—Valve side of Fulton Corliss engine cylinder. (Fulton Iron Works Co., St. Louis.)

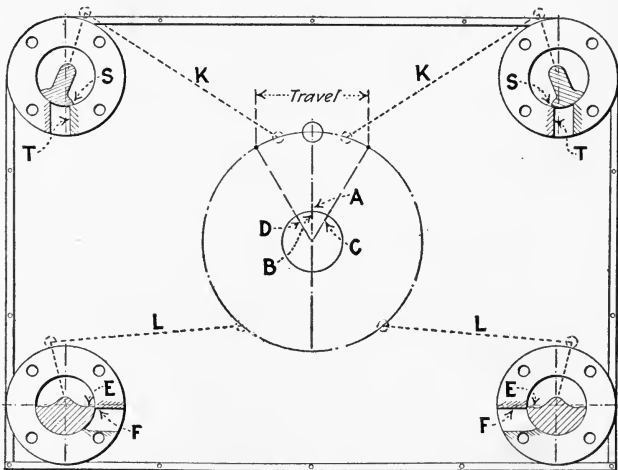

FIG. 233.—Back view of cylinder of Fig. 232 with valves shown in section.

large engines it may be up to $\frac{3}{16}$ in.; but in any case, the amount of this opening must be less than the lap of the steam valves, otherwise there will be danger of steam blowing through without doing work. When rods

K and *L* have been adjusted, the paper may be removed from the wrist plate and the reach rod fastened to it.

3. ADJUST THE LENGTH OF THE REACH ROD (*Q*, Figs. 210 and 232). To do this, loosen the set screws which hold the eccentric to the shaft and turn the eccentric on the shaft—or, without loosening the eccentric, turn the flywheel—until the rocker arm (*R*, Fig. 210) stands exactly vertical—if the flywheel is turned, have someone watch the clearance at the upper ends of the dash-pot rods (see instruction 9). Use a plumb line, employing the same method as shown for the wrist plate in Fig. 230, to establish the vertical position. Fasten the eccentric temporarily to the shaft with a set screw. With the rocker arm, *R*, vertical, adjust the length of the reach rod, *Q*, so that the wrist plate also stands vertical or central—that is, with mark *A* opposite mark *B* (Fig. 228).

4. ADJUST THE LENGTH OF THE ECCENTRIC ROD (*P*, Fig. 210). Again loosen the eccentric set screws and turn the eccentric around on the shaft—or simply turn the flywheel—at the same time watching (or having someone watch) the movement of the mark *A*, Fig. 228, with respect to *B*. If marks *C* and *D* are already on the wrist-plate hub, *A* should move exactly from *C* to *D*. If no marks *C* and *D* exist, *A* should move equal distances to both sides of *B*. If *A* does not move as specified, adjust the length of the eccentric rod, *P* (Fig. 210), until it does. If there were no marks *C* and *D* (Fig. 228), they can now be established for future use, at each of the extreme positions of *A*.

5. SET THE ECCENTRIC ON THE SHAFT. Place the engine on one of its dead centers (Sec. 153). Rotate the eccentric on the shaft in the direction the engine is to run until the admission valve nearest the piston opens by the desired lead. Lead for Corliss engines may be taken as $\frac{1}{64}$ to $\frac{1}{32}$ in. per foot of stroke; see also Table 193. After the proper lead has been given to the valve, secure the eccentric to the shaft and turn the shaft, the eccentric turning with it, in the engine's running direction to the opposite dead center. If the lead at this end is not the same as on the other steam valve, shorten or lengthen the connection between the eccentric and the wrist plate but bear in mind that much adjustment in the length of these connectors is not permissible without resetting the valves with respect to the wrist plate. When both valves show the same lead, make sure that the eccentric is securely fastened to the shaft.

6. ADJUST THE LENGTH OF THE GOVERNOR DROP ROD (*O*, Fig. 210) so that it oscillates its bell crank, *B*, equally out of its horizontal position when the governor balls are brought into their highest and lowest positions.

7. ADJUST THE LENGTHS OF THE GOVERNOR CAM RODS (*H*, Figs. 210, and 232). Place the starting block or stop (*S*, Fig. 247) under the governor cross arm and, after unhooking the reach rod from the wrist plate, turn the wrist plate until marks *A* and *C* (Figs. 228) stand in line. The head-end steam valve should now be wide open. Adjust the length

of the head-end, or longer, cam rod so that the catch blocks are almost ready to separate for this governor position. Move the wrist plate to its other extreme position and adjust the other governor cam rod in the same way. If, now, a $\frac{1}{4}$ in. thick piece of wood or iron is placed between the governor block and the governor cross arm, the steam valves should be both released as the wrist plate is rocked between its extreme positions. To prove the correctness of the cam-rod adjustment, raise the governor balls to about the position where they would be when at work, that is, to a medium height, and block them there. Then with the connections made between the eccentric and the wrist plate, turn the engine shaft slowly in the direction which it is to run, and when the valve is released, measure upon the guide the distance that the crosshead has moved from its extreme position. Continue to turn the shaft in the same direction, and, when the other valve is released, measure the distance through which the crosshead has moved from the other extreme position. If the cam rods are properly set (cut-off equalized), these two distances will be equal to each other. If they are not, adjust the cam rods until both valves are released at equal distances from the beginning of the stroke. The governor should then be blocked into its highest position and the wrist plate rocked back and forth. If the valves do not pick up, the adjustment is satisfactory. If they do pick up, see how wide the valve is opened at the instant of release. The valves should not open more than about $\frac{1}{8}$ in.; otherwise, the engine might race when under no load.

8. SET THE SAFETY TOES OR CAMS (Z, Fig. 234). On some engines, the proper adjustment of the governor cam rods (H, Fig. 210) automatically provides the adjustment of the safety cams. On other engines, the safety cams are adjustable on the knock-off lever. That is, the safety cam is not firmly fixed by the manufacturers to the collar which is operated by the cam rods, H. With either of the above constructions, make sure that, when the governor block (S, Fig. 247) is not under the cross arm, the valves are not opened or picked up by rocking the wrist plate back and forth between its extreme positions; also, when the cross arm rests on the block, make sure that the valves do pick up and open.

9. ADJUST THE LENGTH OF THE DASH-POT RODS (D, Fig. 210) so that, when the wrist plate is in its extreme position, the valve-arm toe (Fig. 234) has equal clearances between the latch stops above and below

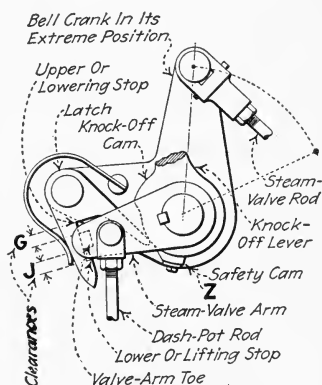

FIG. 234.—Showing clearances which should be equalized when adjusting length of dash-pot rod. (The clearances, G and J, are exaggerated for clearness.)

it, as shown at *G* and *J*, Fig. 234. The lower stop is that catch on the hook or latch which raises the valve arm. The upper stop is the upper side of the latch opening which brings the dash pot to its lowest position if the dash pot does not of itself come down. *This adjustment is very important* because, if no clearance is provided at *J*, the valve may not pick up and open; and, if no clearance is provided at *G*, there is danger of breaking off the bonnet (Fig. 211). It is evident that if there is too little clearance at *G*—too much clearance at *J*—the dash-pot rod will hold up the valve bell crank at the steam-valve-rod end. Thus, when there is too little clearance at *G*, the bell crank cannot turn and must either stop the motion of the wrist plate or move upward as a whole. If the bell crank does thus move upward, it imposes a force against the bonnet on which it is mounted; under such conditions the bonnet is usually broken off. To safeguard against this damage, provide the equal clearances at *G* and *J* as directed above.

10. SO ADJUST THE DASH-POT AIR-REGULATING VALVE that the plunger will drop quickly enough that it need not be pushed down by the latch hook. If the plunger descends too quickly and slams, the valve should be regulated until the proper speed is attained. The dash pot should be well lubricated but not excessively. Too much oil may choke the air passages and cause breakage of the dash pot.

11. CHECK THE EXHAUST VALVE ROD LENGTH by turning the engine over in the direction of running until the crosshead stands the distance from the end of stroke as given under "trial compression" in Table 193. See then if the marks *E* and *F* (Fig. 233) are opposite each other. If they are, the engine will have the compression recommended by that table. If the marks are not opposite, decide whether you want to set the engine for the compression recommended in Table 193, or instead if you want to try the compression as the valves are already set. If you want the recommended compression, adjust the proper exhaust-valve rod (*L*, Fig. 210) so that marks *E* and *F* (Fig. 233) are in line. If you want to try the compression as already set, simply turn the engine until marks *E* and *F* are in line and measure the distance of the crosshead from the end of the stroke. Now turn the engine to the same distance from the end of stroke on the other end and adjust the other exhaust-valve rod so the marks *E* and *F* for the other exhaust valve are in line. The compressions at the two ends are thus checked for equality. This entire step is, however, very frequently omitted by many engineers. After this adjustment is finished the back bonnets or plates may be replaced on the cylinder.

12. ATTACH INDICATORS TO THE ENGINE AND TAKE DIAGRAMS at both ends to see that the valves are properly set. This, of course, is done after the bonnets are replaced and the engine is running under its usual load. It will usually be found that slight imperfections still exist in the valve action; see Sec. 112. These may be corrected. Table 194 will be of great assistance in making the fine adjustments which may now be

necessary. In making these adjustments, one's attention should first be directed to the action of the exhaust valves. After the exhaust valves function properly, the admission valves may be adjusted, if necessary. Very frequently a number of rods must be adjusted to effect a desired change. For this reason setting the valves by indicator diagrams is rather difficult for the inexperienced engineer; hence, the valves should always be set initially, as accurately as possible, by measurement as hereinbefore outlined.

193. Table Of Leads, Laps, And Trial Compressions For Detaching Corliss-Valve Engines.—All dimensions are in inches. Short-stroke engines require slightly smaller values. Long-stroke engines require larger values.

Size of engine	Steam lap ²	Steam lead	Exhaust lap	Trial ¹ compression	Size of engine	Steam lap ²	Steam lead	Exhaust lap	Trial ¹ compression
10 × 24	$\frac{1}{8}$	$\frac{1}{64}$	$\frac{1}{16}$	$1\frac{3}{4}$	38 × 52	$\frac{7}{16}$	$\frac{3}{64}$	$\frac{5}{32}$	3
11 × 24	$\frac{1}{8}$	$\frac{1}{64}$	$\frac{1}{16}$	$1\frac{7}{8}$	20 × 54	$1\frac{5}{32}$	$\frac{3}{64}$	$\frac{3}{16}$	$3\frac{1}{2}$
12 × 30	$\frac{3}{16}$	$\frac{1}{64}$	$\frac{1}{16}$	2	32 × 56	$1\frac{5}{32}$	$\frac{1}{8}$	$\frac{3}{16}$	$3\frac{3}{4}$
14 × 32	$\frac{3}{16}$	$\frac{1}{32}$	$\frac{1}{16}$	$2\frac{1}{3}$	34 × 60	$1\frac{5}{32}$	$\frac{1}{8}$	$\frac{3}{16}$	$3\frac{3}{4}$
16 × 36	$\frac{1}{4}$	$\frac{1}{32}$	$\frac{1}{16}$	$2\frac{1}{3}$	36 × 66	$\frac{1}{2}$	$\frac{1}{8}$	$\frac{7}{32}$	$3\frac{3}{4}$
18 × 40	$\frac{3}{8}$	$\frac{1}{32}$	$\frac{1}{16}$	$2\frac{5}{8}$	40 × 66	$\frac{9}{16}$	$\frac{1}{8}$	$\frac{1}{4}$	$3\frac{3}{4}$
20 × 42	$\frac{3}{8}$	$\frac{1}{32}$	$\frac{1}{16}$	$2\frac{5}{8}$	42 × 60	$\frac{9}{16}$	$\frac{5}{64}$	$\frac{1}{4}$	$3\frac{3}{4}$
22 × 44	$1\frac{3}{32}$	$\frac{1}{32}$	$\frac{1}{16}$	$2\frac{5}{8}$	44 × 60	$\frac{5}{8}$	$\frac{5}{64}$	$\frac{5}{16}$	4
24 × 48	$\frac{7}{16}$	$\frac{1}{32}$	$\frac{1}{16}$	$2\frac{3}{4}$	46 × 66	$\frac{5}{8}$	$\frac{3}{64}$	$\frac{5}{16}$	4
26 × 50	$\frac{7}{16}$	$\frac{3}{64}$	$\frac{1}{16}$	$2\frac{3}{4}$	48 × 66	$\frac{5}{8}$	$\frac{5}{64}$	$\frac{5}{16}$	4

¹ Distance of piston from end of stroke.

² These values are for single-eccentric engines. Double-eccentric engines are usually set for negative steam lap (open port) of one-fourth the full port-opening.

194. Table Of Effects Of Valve-Gear Adjustments On Detaching-Corliss-Valve Engines.—This table applies to a valve mechanism similar to the one of Fig. 210. If a given valve mechanism differs from that shown, the difference must be taken into account.

Part	Change	Effect on							
		Admission		Cut-off		Release		Compression	
		Head end	Crank end	Head end	Crank end	Head end	Crank end	Head end	Crank end
Eccentric	Advanced	Earlier	Earlier	Earlier	Earlier	Earlier	Earlier	Earlier	Earlier
	Turned back	Later	Later	Later	Later	Later	Later	Later	Later
	Lengthened	Later	Earlier	Later	Earlier	Earlier	Later	Later	Earlier
	Shortened	Earlier	Later	Earlier	Later	Later	Earlier	Earlier	Later
Eccentric rod ¹ or reach rod	Lengthened	Later	Later
	Shortened	Earlier	Earlier
	Lengthened	Later	Later
	Shortened	Earlier	Earlier
Steam valve rod ¹	Head end	Later
	Crank end	Later	Later
		Earlier	Earlier
		Shortened	Earlier	Earlier

195. In Setting Valves Of Double-Eccentric Detaching-Corliss-Valve Engines the same processes can be used as given in Sec. 192 for single-eccentric engines with the following differences: The steam and exhaust valves, since they are actuated from separate wrist plates, are set for lap when their respective wrist plates are central. The steam valves are, however, set for negative lap; see Table 193. The rocker arms must be set vertical when the respective wrist plates are vertical. The exhaust eccentric can be set to give compression as specified in Table 193. The steam eccentric is separately set to give the desired lead. When setting the steam eccentric for lead, the style of wrist plate which operates the steam valves determines whether the eccentric should be moved in the same direction as the crank or in the opposite direction. Similarly, an inspection of the valve gear must be made to determine in which direction to turn the eccentric when adjusting the exhaust valves at the point of closure or compression. If the exhaust wrist plate is moved by an attachment above its point of support, as with the steam valves, the eccentric must be moved in the direction in which the engine is to run, and the position of the exhaust eccentric will be nearly that of the steam eccentric. If the point of attachment is below the point of support (Fig. 220), the eccentric must be moved in the opposite direction to that in which the engine is to run.

196. Do Not Try To Lengthen The Cut-Off Of A Corliss Engine.—Many engineers have lost employment for attempting this. In order to make an engine carry more load, it may seem necessary to adjust some rods to lengthen the cut-off (make it later). It is true that this will cause an engine to operate at a slightly higher speed; but, unless great care is taken, one is apt to make the operation of the engine unsafe in case the load were suddenly thrown off of the engine. That is, unless the upper governor collar is raised sufficiently to allow it to rise and thus prevent the admission valves from opening, there is danger, when the load is taken off, that the engine might run away. Also, changing the cut-off by changing rod lengths might prevent the safety cams from coming into operation, if the governor belt should break or run off its pulley. Hence:

197. To Make A Corliss Engine Carry More Load one of only three things should be attempted: (1) *Increase the steam pressure* if the engine is safe for higher pressure. (2) *Reduce the back pressure.* (3) *Increase the engine speed* as directed in Div. 6.

198. In Setting Positively-Operated Corliss Valves And Poppet Valves, if manufacturers' instructions are not at hand or attainable, a greater deal is left to the ingeniousness of the engineer. This must necessarily be, because of the many different forms of operating mechanism which these valves employ. The instructions for several engines are given in following sections and may be studied as a guide in so far as the principles which are given may be readily applied to different engines.

199. The Directions For Setting The Valves Of Ball (Positively-Operated) Corliss Engines, Fig. 235 (Erie Ball Engine Co.), are:

An indicator should always be used in setting the valves of these engines, as without its use only a rough approximation can be made. If it is absolutely necessary to set them without an indicator, the first thing to do is to put the governor eccentric in the shortest travel and block it there. This is very important, as it is impossible to set the valves correctly without doing so. To put the eccentric in its shortest travel, bring the center of the eccentric in line with the center of the suspension pin and the center of the shaft. The governor should then be nearly against the stop which limits its movement in that direction.

With the governor blocked in this position, turn the engine until the admission valve at the crank end moves as far toward opening as it will. It should not open the port at all, but should lack $\frac{1}{32}$ to $\frac{1}{16}$ in. of coming line and line. If it does not, it will be necessary to adjust the length of the reach rod, between the rocker arm and the cylinder, until the valve lacks at least $\frac{1}{32}$ in. of coming line and line. Then, turn the engine to head-end dead center and adjust the link connecting the two gear cases, so that the admission valve at the head end also lacks $\frac{1}{32}$ to $\frac{1}{16}$ in. of opening. This will complete the setting of the admission valves as far as it can be done without an indicator. Upon taking cards it will probably be found that slight changes will be advantageous.

With regard to the exhaust valves; if the cylinder is less than 19 in. bore, it will have a link connecting the cranks of the two exhaust valves. If the cylinder is less than 19 in. bore, this link should be the same length, center to center, as the distance apart of the two valve spindles. For engines having 19 in. or larger bore (Fig. 235), where the exhaust valves are operated from a wrist plate, the short links connecting the

valve cranks to the wrist plate should be adjusted to such a length that, when the wrist plate is turned to bring the centers of the two link pins and the center of the wrist-plate pin in a straight line, the valve will cover the exhaust ports with equal lap on each side of the ports.

Next, roll the engine over by hand and note whether one exhaust valve opens wider than the other. If it does, adjust the length of the reach rod until both valves open equal amounts. Then adjust the position of the eccentric on the shaft so as to have compression begin at the desired distance from the end of the stroke. If an indicator is used, try to adjust so that the compression will run up to about one-half the throttle pressure.

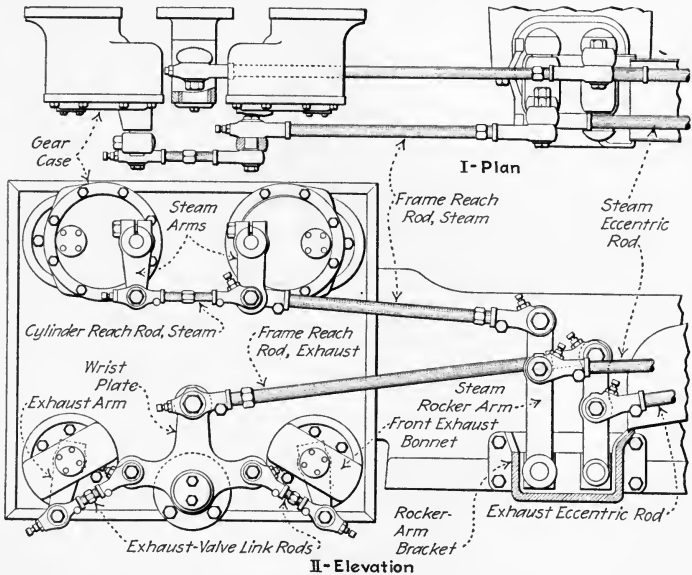

FIG. 235.—Plan and valve-gear side elevation of Ball four-valve (Corliss) engine with exhaust wrist plate. (Erie Ball Engine Co.)

It is best to have a little more compression at the head end than at the crank end, as the piston travels faster at the head end and it requires more compression there to cushion it properly. The proper amount of compression is the amount which makes the engine run most smoothly, and the only way of determining it is by experiment after the engine is in service.

In adjusting the admission valves by the indicator, set them so the cards will be practically alike at no load—slightly higher on the head end if anything—and so the initial pressure shown by the cards at no load will not be over half of the throttle pressure. When this is done the governor will automatically take care of the other loads. At an early

cut-off there will be, and should be, considerable wire drawing. Do not try to prevent this, as it is right to have it that way, and it is necessary for the best economy.

200. The Directions For Setting Valves Of The Fleming-Harrisburg Four-Valve Engine (Harrisburg Foundry and Machine Works) are:

Disconnect the reach rods and locate the dead centers of the engine. After the centers have been located, turn the engine until the steam-valve rocker arm stands plumb. Now adjust the reach rods from it to the valve arms so that the bell cranks are inclined slightly from the vertical center line passing through the valve stems, toward the head end as shown in Fig. 236, where the amount of inclination is indicated at A and A_1 . The amount of this inclination of the steam-valve bell cranks varies for different cylinder sizes and is as stated in Table 201. Next, turn the engine until the exhaust-valve rocker arm stands plumb and adjust the reach rods from it to the exhaust-valve arms so that these incline from each other—each to its own end of the cylinder—by the amount shown in column B of Table 201. For the high-pressure cylinder of a tandem-

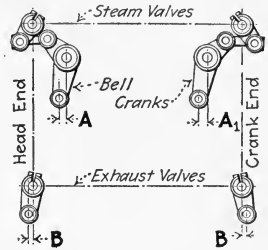

FIG. 236.—Diagram of levers of Fleming-Harrisburg four-valve engines (The dimensions designated by A and B are to be taken from table 201).

compound engine the exhaust-valve arms are turned upward instead of down; this, however, does not change the angle of inclination, these arms being set at the inclination specified in the table, and away from each other as before. For very large low-pressure cylinders, where bell cranks are used on the exhaust valves, these also are set at the inclination specified in this table except that they incline toward each other. To make the eccentric rods of proper length, adjust them so that the rocker arms will travel equally on both sides of their neutral vertical positions.

The valves should next be set in the proper relation to the valve arms before clamping the arms to the stems, and forcing the set screws into place. To do this, place the engine on its head-end dead center and disconnect the springs from the governor. If the governor has been adjusted for proper engine speed measure the length of each spring before disconnecting it so that, when the springs are replaced, the initial tension can be restored. With the springs removed, block the governor in the position of least travel, that is, against the outer stops; remove the valve cover-plates and note the marking of the valves and ports (Figs. 237 and 238). This marking will be found on the ends of the valves and at the ends of the cylinder ports, the steam edges and exhaust edges all being marked S .

Now, on simple engines and on the high-pressure cylinders of compound engines, set the head-end steam valves so as to overlap the port edges, *S*, by about $\frac{1}{16}$ in., which may be termed negative lead. Then clamp this

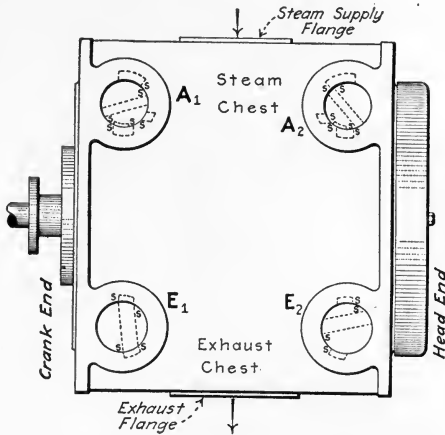

FIG. 237.—Exterior outline of Harrisburg four-valve engine.

valve arm on the stem and turn the engine in the direction in which it will run to the crank-end center. Set the crank-end steam valve with about $\frac{1}{32}$ in. lap or negative lead and clamp the valve arm on the stem.

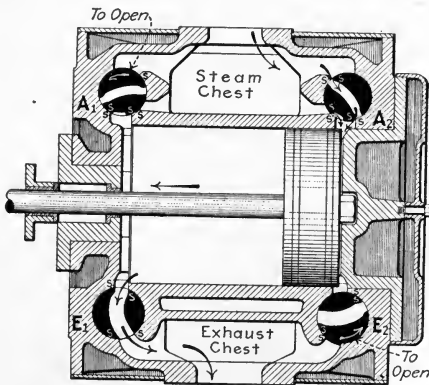

FIG. 238.—Vertical section through cylinder and valves of Harrisburg four-valve engine.

This negative lead is especially necessary for condensing engines, to prevent the engine from running away when the load is thrown off. The ports usually do not open to steam at all with the governor blocked in this

position, and positively must not open more than enough to admit sufficient steam to overcome the friction of the engine.

The blocking of the governor should now be changed. Fix it in such a position as will give about $\frac{1}{3}$ cut-off. To do this, the point of cut-off should be located on the guides by making marks on the lower guide in line with the mark on the crosshead shoe for each dead-center position, and dividing the distance between them into three equal parts. Now turn the engine over until the mark on the crosshead shoe is in line with the point on the guide corresponding to $\frac{1}{3}$ cut-off for the head end and block the governor so that the valve is line and line at the steam edge. Next, turn the engine over until the valve shows the cut-off on the crank end. It will be noted that the crosshead has not traveled the full $\frac{1}{3}$ stroke, as indicated by the crosshead and guide marks, by from $\frac{3}{4}$ to 1 in., depending on the size of the engine. An adjustment of the valves can be made, which will lessen this amount, but it will increase the difference in lead between the two ends. Hence, this adjustment must be made to the best advantage, lead and cut-off considered. It will be noted that lead materially increases for later points of cut-off and tends to make the engine pound if too great.

The exhaust valves may be properly set by turning the engine over to bring the valve arms and rocker arms into their neutral positions. With the engine in this neutral position, adjust the head-end exhaust valve with about $\frac{3}{16}$ in. lap and the crank-end exhaust valve with $\frac{1}{4}$ in. lap. Now, for determining trial compression make a mark on the guides measuring from each dead-center mark: For the high-pressure cylinder of a compound engine the mark should be about $1\frac{1}{2}$ in. from each end of the stroke. For a simple engine or the low-pressure cylinder of a compound engine the mark should be about 3 in. from the end of the stroke. These measurements will increase for engines having 24 in. or larger stroke. Now clamp the two exhaust valves on the valve stems, and turn the engine over in the direction in which it will run until the crosshead mark coincides with the head-end mark just made on the guides. This will bring the crank pin below the center line of the engine, and the piston in position for compression at the head end of the cylinder. With the crosshead still in this position, turn the eccentric around on the shaft until the valve and port edges (*S*, Fig. 237) coincide for the head-end valve. This valve is now in proper relation to the crank for compression and the eccentric set screw should be set down on the shaft. The engine should now be turned over until the crosshead mark coincides with the crank-end compression mark on the guide, when the two edges *S* of the crank-end exhaust valve and seat should coincide. If they do not, loosen the valve stem in the arm and turn the valve so that these two marks do coincide and fasten it again. This valve is also now right for compression. With the setting just described, the crank-end exhaust port should be about one-half open when the engine is on head-end dead center. This should also be true for the head-end valve when the engine is turned on the crank-end center.

In valve setting, always (Sec. 153) turn the engine over in the direction it runs, never turning it past a desired point and then back to it, as the lost motion will prevent accurate adjustment. When turning an engine over on which the rods have not been adjusted, care should be taken to insure against jamming of the valve gear; that is, forcing it beyond its normal travel in one direction and straining it, due to the rods being too long or too short.

201. Table Showing Advance Of Steam And Exhaust Valve Arms On Harrisburg Four-Valve Engines.—Dimensions are all in inches and refer to Fig. 236.

Cylinder sizes	Advance steam valve bell cranks		Advance exhaust valve arm, <i>B</i>
	<i>A</i>	<i>A</i> ₁	
9 -10½	7/16	7/16	0
11 -14½	9/16	3/8	0
15 -17	1 1/8	3/4	0
17½-20	7/8	3/4	1/4
19½-24½	1 1/4	7/8	1/4
25 -29	1 3/8	1	7/8
30 -34½	1 3/8	1	7/8
35 -40½	1 1/2	1 1/8	1 1/8
46 -56	1 1/2	1 1/8	1 1/8

202. Directions For Setting Valves Of Ridgway Four-Valve Engines.—All engines are set in the shop to dimensions shown in Table 203 which apply to Figs. 239 and 240. They are then set by indicator and reference marks are made on all eccentric and valve rods. These marks are 3 in. apart on small engines and 4 in. apart on large engines. All arms are marked with a chisel so that if at any time they have moved it will be possible to return them to their original location. To set the valves: Use the marks if possible. If marks are not visible, set to the dimensions of Table 203. Then use an indicator to perfect the setting; see Sec. 112 and Sec. 175. Table 204 shows the results of adjustments to the simple and cross compound engines. Table 205 shows the results of adjustments to the four-valve tandem compound engines.

203. Table Of Dimensions For Setting Ridgway Simple Four-Valve Engines.—

The steam valves are set with the governor bar blocked against the outer stop, thus: When crank is on head-end dead center, set head-end valve with $\frac{1}{32}$ in. lead. When crank is on crank-end dead center, set crank-end valve with $\frac{1}{16}$ in. lead. Set exhaust valves and eccentric to the following dimensions which apply to Figs. 239 and 240.

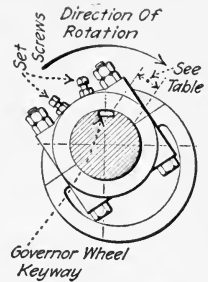

FIG. 239.—Showing method of locating exhaust eccentric on shaft of Ridgway engine.

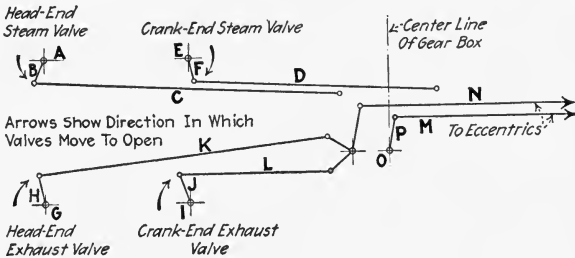

FIG. 240.—Diagram of valve gearing of Ridgway simple four-valve engine.

Bed	Stroke	Compression		Length between centers of valve rods				Location of exhaust eccentric on shaft
		Head	Crank	Steam valve rods		Exhaust valve rods		
				C	D	K	L	
D	12-14	4½"	4"	2'-10½"	2'-5¼"	2'-9½"	17⅝"	2"
F	14-16	5"	4½"	3'-2¼"	2'-6¾"	3'-1½"	18¾"	2⅜"
H	16-18	5½"	5"	3'-7¼"	2'-9¼"	3'-6¼"	19¾"	3"
J	18-20	6½"	6"	3'-11½"	2'-11¼"	3'-11¼"	22"	3¼"
K	22-24	7"	6½"	4'-3½"	2'-11¼"	4'-3¼"	22"	3¼"
L	20-22-24	7½"	7"	4'-8½"	3'-5¾"	4'-7¾"	2'-2¼"	3⅝"
M	26-28	8"	7½"	5'-0½"	3'-5¾"	4'-11¾"	2'-2¼"	3⅝"
N	24-26-28	8½"	8"	5'-5¼"	4'-0"	5'-4"	2'-5¼"	4½"
O	30-32	9"	8½"	5'-9¼"	4'-0"	5'-8"	2'-5¼"	4½"
P	28-30-32	9½"	9"					
Q	34-36	10"	9½"					

204. Table Of Results Of Adjustments To Ridgway Simple And Cross Compound Four-Valve Engines.—The letters referred to are shown on Fig. 240.

Steam valves				
Adjustment	Head end		Crank end	
	Admission	Cut-off	Admission	Cut-off
Turn stem <i>A</i> in arm <i>B</i> counter-clockwise or shorten rod <i>C</i> .	Earlier or more lead	Later	Unchanged	Unchanged
Turn stem <i>E</i> in arm <i>F</i> clockwise or lengthen rod <i>D</i> .	Unchanged	Unchanged	Earlier or more lead	Later
Lengthen reach rod <i>M</i> or turn shaft <i>O</i> in arm <i>P</i> counter-clockwise.	Earlier or more lead	Later	Later or less lead	Earlier

Exhaust valves				
Adjustment	Head end		Crank end	
	Release	Compression	Release	Compression
Turn stem <i>G</i> in arm <i>H</i> clockwise or shorten rod <i>K</i> .	Earlier	Later	Unchanged	Unchanged
Turn stem <i>L</i> in arm <i>J</i> clockwise or shorten rod <i>L</i> .	Unchanged	Unchanged	Earlier	Later
Shorten reach rod <i>N</i>	Earlier	Later	Later	Earlier
Turn exhaust eccentric around shaft in direction of rotation....	Earlier	Earlier	Earlier	Earlier

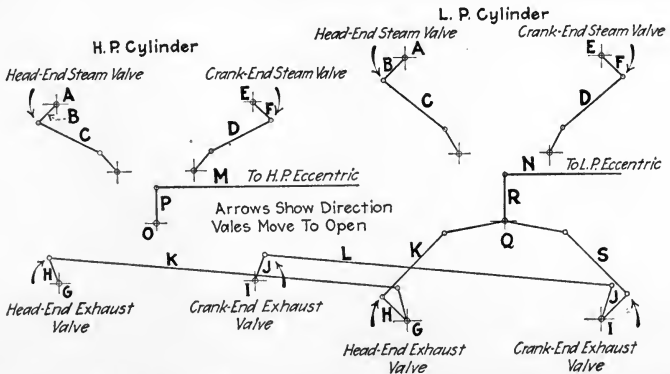

FIG. 241.—Diagram of valve gearing of Ridgway tandem-compound four-valve engine.

205. Table Of Results Of Adjustments To Ridgway Tandem Compound Four-Valve Engines.—The letters referred to are shown on Fig. 241.

High-pressure steam valves				
Adjustment	Head end		Crank end	
	Admission	Cut-off	Admission	Cut-off
Turn stem <i>A</i> in arm <i>B</i> counterclockwise or shorten rod <i>C</i> .	Earlier or more lead	Later	Unchanged	Unchanged
Turn stem <i>E</i> in arm <i>F</i> clockwise or shorten rod <i>D</i> .	Unchanged	Unchanged	Earlier or more lead	Later
Lengthen reach rod <i>M</i> or turn shaft <i>O</i> in arm <i>P</i> counterclockwise.	Earlier or more lead	Later	Later or less lead	Earlier
Low-pressure steam valves				
Adjustment	Head end		Crank end	
	Admission	Cut-off	Admission	Cut-off
Turn stem <i>A</i> in arm <i>B</i> counterclockwise or shorten rod <i>C</i> .	Earlier or more lead	Later	Unchanged	Unchanged
Turn stem <i>E</i> in arm <i>F</i> clockwise or shorten rod <i>D</i> .	Unchanged	Unchanged	Earlier or more lead	Later
Lengthen reach rod <i>N</i> or turn shaft <i>Q</i> in arm <i>R</i> counterclockwise.	Earlier or more lead	Later	Later or less lead	Earlier
Turn low-pressure eccentric around shaft in direction of rotation.	Earlier or more lead	Earlier	Earlier or more lead	Earlier

High-pressure exhaust valves

Adjustment	Head end		Crank end	
	Release	Compression	Release	Compression
Turn stem <i>G</i> in arm <i>H</i> clockwise or shorten rod <i>K</i> .	Earlier	Later	Unchanged	Unchanged
Turn stem <i>L</i> in arm <i>J</i> counter-clockwise or lengthen rod <i>L</i> .	Unchanged	Unchanged	Earlier	Later
Shorten reach rod <i>N</i> .	Earlier	Later	Later	Earlier
Turn low-pressure eccentric around shaft in direction of rotation.	Earlier	Earlier	Earlier	Earlier

Low-pressure exhaust valves

Adjustment	Head end		Crank end	
	Release	Compression	Release	Compression
Turn stem <i>G</i> in arm <i>H</i> clockwise or shorten rod <i>K</i> .	Earlier	Later	Unchanged	Unchanged
Turn stem <i>L</i> in arm <i>J</i> counter-clockwise or shorten rod <i>S</i> .	Unchanged	Unchanged	Earlier	Later
Shorten reach rod <i>N</i> .	Earlier	Later	Later	Earlier
Turn low-pressure eccentric around shaft in direction of rotation.	Earlier	Earlier	Earlier	Earlier

206. The Directions For Setting Poppet Valves On Ames "Una-flow" Engines (Ames Iron Works) are: The valve gear should be assembled and set according to the tram marks, *M*, found on the rods and rod heads as shown in Fig. 225. The proper distance, in inches, between punch marks on the rod and head will be found stamped on the rod. If, for any reason, the marks cannot be found, a preliminary setting of

the valves can be made as follows and the final setting made after an indicator has been used on the engine. (See Fig. 245 for illustration of complete engine.)

1. TWO-VALVE TYPE, straight un-a-flow. (a) MAIN VALVES. Connect the eccentric rod to the rocker arm and adjust the length of the rod so that the rocker travels equal distances to both sides of the vertical when the engine is turned over by hand. Then adjust the valve stems (*V*, Fig. 242) so that there will be about $\frac{3}{1000}$ in. space between the flat part of the cams and the rollers in the roller rods. This space can be measured with a thickness gage inserted through the peephole opening in the side of the bonnet. This space will increase after the engine has been warmed by the high-temperature steam and should be about $\frac{3}{1000}$ in. when the engine is in normal operation. Next, connect the reach rod, *R* (Fig. 225), to the crank-end roller rod, *C*, and adjust the length of the reach rod so that, with the engine on crank-end dead center, the roller, *Q* (Fig. 242) in the crank-end roller rod just touches the cam, *M*. Then, with the engine on head-end dead center, adjust the ball rods, *B*, over the cylinder, so that the roller in the head-end roller rod just touches the cam as at the crank end.

With the engine running under normal load, take indicator diagrams and then make whatever adjustments seem necessary to make the diagram as desired. In making these adjustments, give attention first to the crank-end valve. Then, after that is properly adjusted, set the head-end valve. The effects of adjustments of the reach and ball rods are given in Table 207. Bear in mind that the valve motion is very sensitive to adjustment and that very little change in rod length is required to make a very material change in the indicator diagrams. In most cases, the lead will show later and the admission line will not be as good at the head end as at the crank end, and if there is any difference in the compression it will show highest at the head end.

Care should be exercised when increasing the lead on the valves, while the engine is carrying load, not to increase it to such an extent that the governor will lose control of the engine's speed when operating at friction load or no load. This condition may occur if the rollers are adjusted so far under the cams with the engine carrying a load that, when the load is thrown off and the governor is on its minimum travel, the rollers may still be contacting with the cams and lifting the valves slightly. Steam would thus be admitted to the cylinder causing the governor to

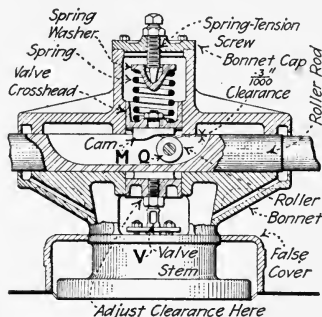

FIG. 242.—Section through bonnet and valve of Ames uniflow engine.

lose control of the engine at friction or light load. If this occurs it is only necessary to decrease the lead to such an extent that, with the maximum steam pressure, the governor will control the engine at friction load. Typical indicator diagrams are shown in Fig. 243.-I.

If the engine is to operate sometimes condensing and sometimes non-condensing, the valves should be set for condensing operation, as a condensing engine will not operate satisfactorily with as much lead when

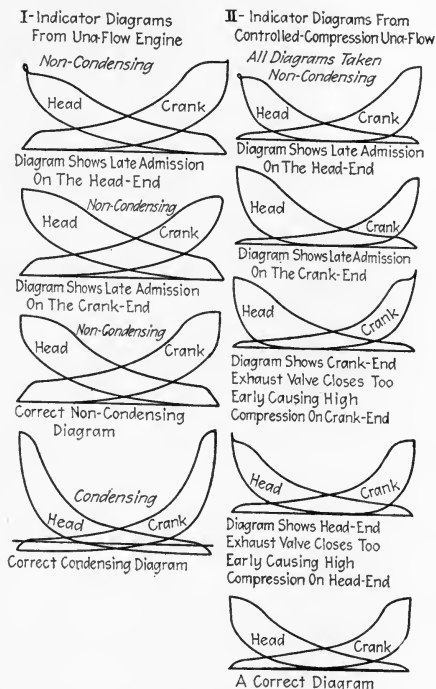

FIG. 243.—Typical indicator diagrams from Ames "una-flow" engines.

operating condensing as it will when operating non-condensing, due to the action of the vacuum in addition to the very early admission of steam.

(b) **AUTOMATIC BY-PASS VALVES** (Fig. 244). All engines built for condensing operation are furnished with by-pass valves which are automatically controlled by the pressure in the exhaust pipe or exhaust belt of the engine. The object of the by-pass valves is to automatically increase the volumetric clearance of the engine in case of loss of vacuum or in case the vacuum falls below a predetermined point, also to automatically decrease the clearance when the vacuum is restored or raised

above the predetermined point. The additional clearance space is within the cylinder head at the bottom. The by-pass valve opens or closes communication between the cylinder and this additional clearance volume. The valve of Fig. 244 does not operate with each stroke of the engine but only when the vacuum changes through the predetermined point.

The vacuum acts upon a piston, *P* (Fig. 244), which is within a cylinder, *C*, and thus allows the atmospheric pressure from above to force the piston downward against a spring, thus drawing down the valve and closing it. If the vacuum falls below the predetermined point, the spring forces the piston upward and opens the valve. By adjusting the tension on the spring, the valve can be made to operate at any desired point within

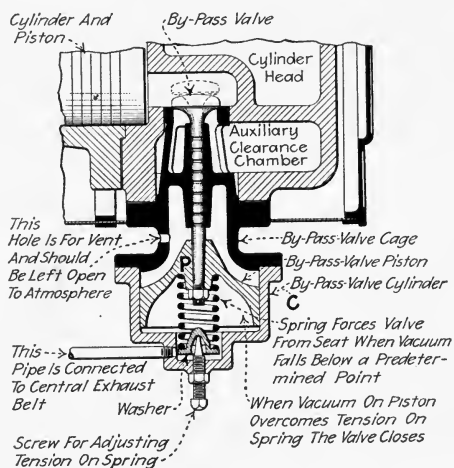

FIG. 244.—Section through automatic by-pass valve of Ames "una-flow" engine.

reasonable limits. When operating at a vacuum of 24 to 26 in. of mercury, the spring should be adjusted to operate at 15 to 18 in. vacuum. These valves should be removed at least once every six months and examined to insure that they are not gummed or corroded.

2. **FOUR-VALVE TYPE**, controlled-compression una-flow. The steam valves are set exactly as on the two-valve type. If no marks are available for setting the eccentric, it should be so located that the center line of the keyway is, in rotation, 52 to 53 degrees back of the crank pin, except on 34 to 36-in. stroke engines, for which engines the center line of the keyway should lead the crank pin in rotation by approximately 127 to 128 degrees. Then adjust the eccentric rod, *E* (Fig. 245), so that the exhaust rocker arm, *R*, will travel equal distances to both sides of the vertical.

Remove the covers on the opposite side of the cage from the rocker lever. This will allow full view of the cams, Q (Fig. 225). The roller in the small crosshead on the exhaust valve stem should be adjusted, through the small rectangular opening on the side of the cage, so that there will be about $\frac{3}{1000}$ in. space between the cam and roller, at a point on the round part of the cam just before the lifting part comes into contact with the roller. The smaller this space is kept, the more quiet will be the operation of the valves; but, to insure proper closing of the valves, some clearance must be provided.

Turn the engine over in direction of rotation until it is on dead center (Sec. 153) and make a mark on the side of the crosshead shoe and a similar mark on the crosshead guide directly in line with the one on the crosshead shoe. Turn the engine to the other dead center and mark the guide at that end in the same way. This will provide for conveniently measuring

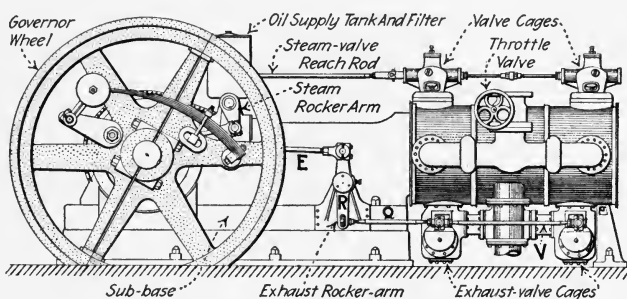

FIG. 245.—Governor and valve-gear side of Ames "controlled compression una-flow" engine. (Ames Iron Works.)

the distance the piston may be from the end of its stroke. Turn the engine over until the piston is 1 in. from head-end center and the crank pin below the engine's center line. In this position adjust the exhaust reach rod, (Fig. 245) Q, so that the cam in the crank-end cage is just touching the roller. Turn the engine to within 1 in. of crank-end dead center and adjust the exhaust valve rod, V, so that the cam in the head-end cage is barely touching its roller.

Further adjustments may be made, after the engine is running, from the indicator diagrams. In making adjustments on the reach rod and valve rod, it should be remembered that the exhaust valves open as their small levers move toward the ends of the cylinder—except on 34-in. and 36-in. stroke engines where they open when the levers move toward the center of the cylinder. The effects of adjustments are given in Table 207 and typical indicator diagrams are shown in Fig. 243.-II.

207. Table Of Effects Of Adjustments To Valve Gear Of Ames "Una-Flow" Engines.

Steam valves				
Adjustment	Effect on admission		Effect on load distribution	
	Head end	Crank end	Head end	Crank end
Shortening reach rod over frame.....	Earlier	Later	Heavier	Lighter
Lengthening reach rod over frame.....	Later	Earlier	Lighter	Heavier
Shortening ball rods over cylinder.....	Earlier	Unchanged	Heavier	Lighter
Lengthening ball rods over cylinder	Later	Unchanged	Lighter	Heavier

Exhaust valves						
Adjustment	Engines up to 30-in. stroke			Engines 34-in. to 36-in. stroke		
	Crank-end valve		Head-end valve	Crank-end valve		Head-end valve
	Opens	Closes	Opens	Opens	Closes	Opens
Shortening reach rod, Q (Fig. 245) ..	Earlier	Later	Earlier	Later	Earlier	Later
Lengthening reach rod, Q	Later	Earlier	Later	Earlier	Later	Earlier
Shortening valve rod, V	Unchanged	Unchanged	Earlier	Unchanged	Earlier	Later
Lengthening valve rod, V	Unchanged	Unchanged	Later	Unchanged	Later	Earlier
Moving exhaust eccentric around on shaft in direction of rotation.....	Later	Later	Earlier	Earlier	Later	Later
Moving exhaust eccentric around on shaft in opposite direction to rotation.....	Earlier	Earlier	Later	Later	Earlier	Earlier

208. In Setting The Valves Of A Chuse Condensing Uniflow Engine, Figs. 227 and 391, proceed as follows (Chuse Engine and Manufacturing Company):

First loosen the lock-ring nut on the ball-and-socket joint on the crank-end roller slide. This will permit dropping down the reach rod which extends from the rocker arm to the roller slide, so that the slides can be moved back and forth by hand. Next, remove the covers or caps from the camheads. This will uncover the upper ends of the cam crossheads, to which the cams are fastened. It will also uncover the upper side of the slides, in which the rollers are located. Then push one of the slides just far enough so that the roller will be under the thin end of the cam. Observe carefully that the proper clearance exists between the roller and the cam at this point by introducing between them a piece of an indicator card or a $\frac{1}{1000}$ -in. thickness gage. If the cam is too low, so that a paper will not enter, raise the cam crosshead by loosening the locknut on the valve stem at the lower end of the cam crosshead and then screwing out the valve stem slightly—just enough to provide the necessary clearance between the cam and the roller.

Then tighten the locknut and again try the clearance. Too much space between the cam and the roller will cause the roller to strike too hard against the incline of the cam, thereby producing noisy running. It is also well to lift up the cam crosshead and valve and release them to insure that the valve is solidly on its seat. After adjusting both crank-end and head-end valves in this manner, the cam heads should be replaced. Be sure that the springs are in their proper positions before tightening down the cap screws on these covers. Then connect the reach rod to the roller slide again and place the engine on the exact crank-end dead center.

With the engine on crank-end dead center, lengthen or shorten the reach rod until the roller lifts the crank-end valve $\frac{1}{32}$ in. This lift can best be measured with a small inside caliper by setting it to the distance between the upper end of the stem sleeve and the under side of the locknut on the valve stem. After the crank-end valve has been set in this manner, turn the engine over to the exact head-end dead center. Increase or decrease the distance between the slides, by lengthening or shortening the rod which connects the two slides, until the head-end valve is lifted just $\frac{1}{32}$ in., as was the crank-end valve before. This completes the valve setting so far as it can be done by measurement. The final setting is made after taking indicator diagrams; see Sec. 112.

209. The Directions For Setting Valves Of "Lentz" Poppet-Valve Engines (Erie City Iron Works) are: The setting of all valves except those which are controlled by the governor is left to the operating engineer, insofar as there are no rigid rules laid down by the manufacturers. An approxi-

mate setting can be made by measurement as directed below—the final setting can then be made from indicator diagrams. See Fig. 383 for illustration of complete engine.

1. STEAM VALVES. The steam valves which are under the governor's control have their eccentric driving block (*D*, Fig. 246) keyed to the lay-shaft, *L*. The correct setting can be checked as follows: Turn the lay-shaft until the eccentric rod stands at right angles to the driving block, *D*, as shown in Fig. 246. If the governor is now opened and closed from minimum to maximum position, the cam lever should show a hardly perceptible motion. This is the correct position for the lead, and the valve spindle must be so adjusted that the roller just touches the curve of the cam and that with the least motion of the side shaft, the

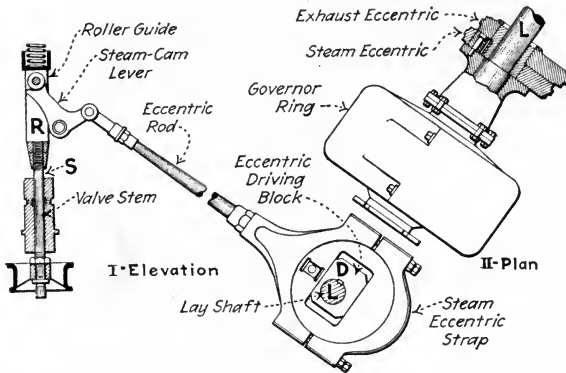

FIG. 246.—High-pressure steam-valve gear of "Lentz" engine. (Erie City Iron Works.)

valve lift commences. In case the steam valves ever have to be taken out, the correct position in which to replace them may be determined as follows: It will be noticed that there is a small center-punch mark in the valve stem, *S*, and one in the roller guide, *R*. When, at the factory, the valve is properly located, these marks are exactly 2 in. apart. To replace the valve it is only necessary to set a pair of dividers to 2 in. and adjust the length of the valve spindle until these marks are just 2 in. apart. If the engine has been in operation several years, this dimension may be slightly different on account of natural wear on the roller and cam. The final position may then be determined by turning the valve stem a minute fraction of a turn until a position is found where the cam will engage the roller with an easy and smooth effect without jar and noise. All other eccentrics being clamped to the shaft, they can be easily turned in any direction. By turning the low-pressure steam eccentric forward, the lead is increased and cut-off made later; and vice versa when turning in the opposite direction. By "forward" is meant in the direction of rotation of the side shaft, and by backward, against the rotation

of the side shaft. When shortening the eccentric rods on the steam valves, lead is increased and cut-off made later, and vice versa when lengthened.

2. EXHAUST VALVES. When turning the exhaust eccentric forward, release and compression are made earlier, and vice versa when turned backward.

3. VALVE SPRINGS. Valve springs should be so adjusted as to keep the roller and cam in contact without throwing unnecessary load on the valve gear.

210. The Directions For Setting Valves Of Vilter Poppet-Valve Engines (Fig 226) are: Since, on these engines, the valve-operating mechanism comprises the same essential parts as does that of a double-eccentric Corliss-valve engine the setting of the valves is almost the same as given in Sec. 195 for the latter. In the following directions only those adjustments which differ essentially from the setting of Corliss valves are treated in detail.

ADJUST THE ECCENTRIC RODS AND REACH RODS, as for a double eccentric Corliss engine, so that the rocker arms and wrist plates travel equal distances to both sides of their central positions.

ADJUST THE STEAM VALVE RODS so that—when the steam poppet valve is on its seat and the steam wrist plate is in its extreme position—there is about $\frac{3}{8}$ in. clearance at the latch for hooking in.

SET THE STEAM ECCENTRIC by setting the engine on dead center and rotating the eccentric on the shaft in the direction the engine is to run until the steam valve which is nearest the piston has $\frac{1}{32}$ in. lead or opening. Then tighten the eccentric to the shaft.

ADJUST THE GOVERNOR RODS, with the governor blocked about 1 in. above the automatic safety stop or block (Fig. 440), so that cut-off occurs in equal fractions of the forward and return strokes. This is done by adjusting the rods connecting the knock-off levers of the head-end steam valves with those of the crank-end steam valves. Then, with the governor resting on the safety stop, adjust the governor rods from the governor to the crank-end valves so that cut-off takes place when the steam wrist plate has nearly reached the end of its travel. Cut-off can be observed by watching for the spring-loaded dash-pot piston to drop down.

ADJUST THE EXHAUST VALVE RODS so that, with the exhaust wrist plate in its central position, the exhaust cams only touch the steel rollers on the exhaust-valve stems. The cams should not, in this position, lift the valves from their seats.

SET THE EXHAUST ECCENTRIC so that it travels about 60 deg. behind the crank. In order to increase the compression and provide earlier release, move the exhaust eccentric toward the crank or in the direction of rotation. Later compression and release are provided by turning the

exhaust eccentric in a direction the reverse of that in which the engine runs.

MAKE FINAL ADJUSTMENTS FROM INDICATOR DIAGRAMS as with all other engines; see Secs. 112 and 175.

QUESTIONS ON DIVISION 5

1. State briefly the reasons for employing Corliss or poppet valves.
2. Under what conditions might it not be advisable to use an engine with Corliss or poppet valves? Why?
3. What are the distinct advantages of Corliss valves?
4. What features distinguish a well-designed Corliss valve?
5. Explain with a sketch the operating mechanisms used with positively-operated Corliss valves. What variations are there?
6. State the advantages and disadvantages of positively-operated Corliss valves. To what kinds of engines are they best suited?
7. Illustrate with a sketch and explain the operation of the usual detaching Corliss-valve releasing mechanism.
8. Describe, with a sketch, the entire valve-operating mechanism of a detaching Corliss-valve engine.
9. What are the advantages and disadvantages of detaching Corliss valves?
10. Why are two eccentrics sometimes employed with Corliss valves? Explain fully the limitations of using only one eccentric.
11. What is the cut-off range of a single-eccentric Corliss engine?
12. Into what three classes may trip gears be divided? What are the merits of each class?
13. What is the principal function of a dash pot in connection with a trip gear? What secondary function has the dash pot?
14. What provision should be made in the valve mechanism to prevent inoperation of the engine in the event that a dash pot ceases to function?
15. What are the principal advantages and disadvantages of poppet valves?
16. What is likely to cause leaking of poppet valves?
17. Explain, with slide valve analogies, the difference between single and double-beat poppet valves.
18. Explain, with sketches, the operation of as many different poppet-valve operating mechanisms as you can.
19. Take the sketch made in answering Question 8 and explain the adjustment of every part thereon which can be adjusted.
20. What marks are necessary in setting Corliss valves? Show a sketch. If these marks did not appear on an engine, how would you establish them?
21. How does the valve-setting of double-eccentric Corliss engines differ from that of single-eccentric engines?
22. Is it advisable to try to lengthen the cut-off of a Corliss engine? Why?
23. How may a Corliss engine be made to deliver more power?
24. Can marks be used to advantage in setting positively-operated Corliss valves?
25. In the absence of manufacturer's instructions, how would you attempt to set the valves of a positively-operated Corliss-valve engine which has a shaft governor, has its steam valves operated from a gear box at the side of the frame, and has its exhaust valves driven from a wrist plate? How if the steam valve gearing were located immediately at the valve bonnet?
26. How would you set the admission valves of a uniflow engine which are operated by overhead reciprocating cams driven by a shaft governor?
27. How would you set poppet exhaust valves which are operated by cams which are rotated by connectors to an eccentric on the main shaft?
28. Describe the setting of poppet valves which are operated from a lay shaft.
29. Explain the construction and valve setting of a Corliss-gear poppet-valve mechanism.
30. Explain how you would make adjustments to correct the faults which are revealed by Figs. 102 and 103.

DIVISION 6

FLY-BALL STEAM-ENGINE GOVERNORS, PRINCIPLES AND ADJUSTMENT

211. A Steam-Engine Governor (Fig. 247; see also Sec. 74 and Fig. 52), as commonly used in connection with a stationary steam engine, is a device for keeping the speed of the engine reasonably constant. A properly operating gover-

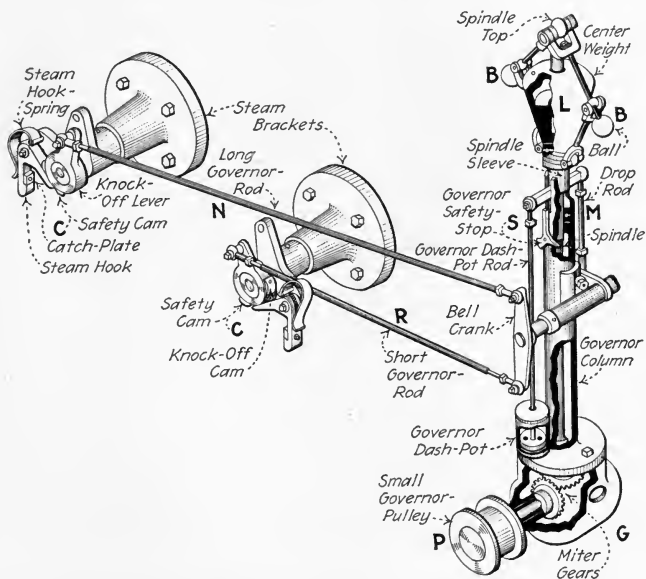

FIG. 247.—Governor for Corliss engine. (Harding and Willard, MECHANICAL EQUIPMENT OF BUILDINGS.)

nor “may be regarded as a permanent watchman, overlooking the ‘engine’ with an observant eye. If more power is required, it (*the governor*) drops, apparently of its own account and lets the engine take more steam; and, as the load decreases, it rises and reduces the amount of steam to suit. We owe this

device to the genius of James Watt.” (From H. Hamkens, STEAM ENGINE TROUBLES.) The principle of Watt’s pendulum or fly-ball governor is still widely used but has been modified to meet modern conditions.

NOTE.—A GOVERNOR IS NOT NECESSARY UNDER SOME CONDITIONS (Graph B, Fig. 248), such as in marine engine service, because the work done by such an engine increases rapidly with the engine speed. There

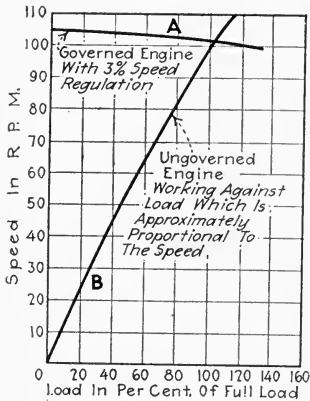

FIG. 248.—Graphs showing speed variation with load of governed and ungoverned engines.

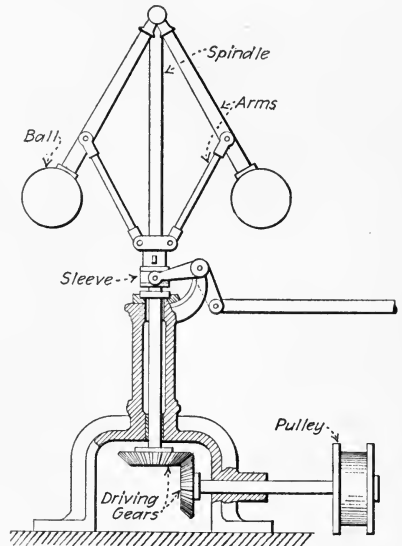

FIG. 249.—Simple pendulum or “Watt’s” Governor.

is then a resultant constant speed for any amount of steam which may be admitted to the engine. But in most stationary-engine service (constant-speed service) the load may vary greatly and the engine, if not governed nor regulated by hand, would slow down, whenever the load happened to increase; or “run away” whenever the loads were diminished. Hence, for such service a governor is necessary.

212. The Two Principal Kinds Of Steam-Engine Governors

(see Sec. 74) are: (1) *Fly-ball governors*, which are discussed in this division. (2) *Shaft governors*, which are discussed in Div. 7. A fly-ball governor (Figs. 247, 249 and 250) is one which depends for its action (Fig. 252) on the centrifugal force

developed in two or more weights which are rotated about a (usually) vertical spindle which is provided for the purpose. Increased rotational speed causes the weights to shift radially from the spindle axis and thereby move some part which regulates the amount of steam admitted to the engine (Sec. 74).

213. Two Forces Are Employed By Steam-Engine Governors For Detecting Variations In Engine Speed : (1) *Centrifugal force*. (2) *Inertia or tangential inertia*. Centrifugal force is ordinarily the only force employed in fly-ball governors for

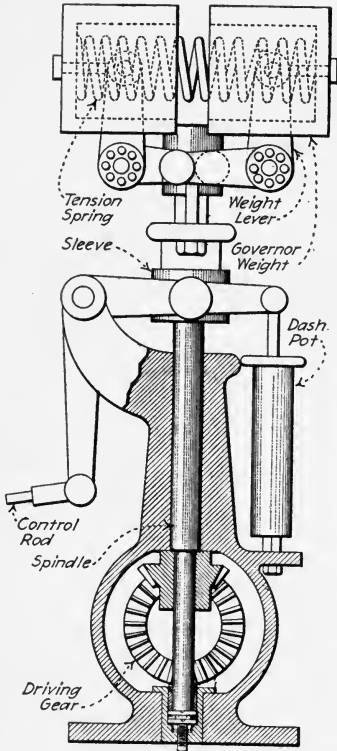

FIG. 250.—Governor employing horizontal tension spring. (Hamkens, STEAM ENGINE TROUBLES.)

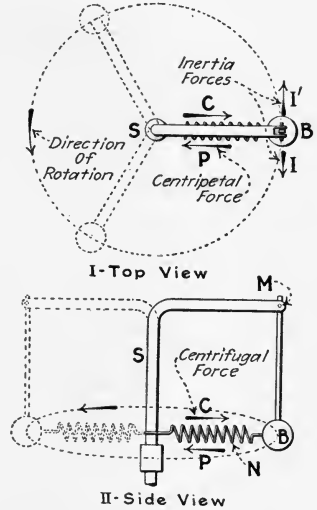

FIG. 251.—Showing forces developed by a revolving governor weight.

detecting speed variations. Inertia is employed, as will be explained in Div. 7, in shaft governors. Note, however, that inertia and centrifugal force are both employed in such governors—never inertia alone. *Centrifugal force is the tendency of a rotating body to move away from its axis of rotation.* In governor design, this force is opposed by a *centripetal force*

which is introduced by means of arms, weights, springs or other mechanism. A centripetal force is one which opposes a centrifugal force; for equilibrium the centripetal force must be exactly equal and opposite to the centrifugal force.

EXPLANATION.—Consider (Fig. 251) a ball, B , which is pivoted at M and rotating about a vertical spindle, S . There is a centrifugal force, C , tending to make the ball move out radially from the spindle, S . The ball is prevented from so moving by a spring, N , which exerts a centripetal force, P , just equal to the centrifugal force. If the ball is started suddenly, it tends to “hang back” and exerts a force, I , due to its inertia. If the ball is stopped suddenly, it tends to continue moving and exerts a force, I' , also due to inertia.

214. All Fly-Ball Governors Permit Some Variation In Engine Speed.—It has been found impractical to endeavor to maintain the speed of an engine exactly constant. It will be noted from subsequent descriptions of governor operation that the governor does not change its position until a change in speed occurs; hence, it is evident that a speed change is necessary to cause a governor to operate. There is, moreover, when an engine is properly governed, a definite speed corresponding to each load, that is, the speed varies with the load. The graph A (Fig. 248) is characteristic of this sort of performance. The speed variation from no load to overloads may be made very small if so desired. Variation in speed of 5 per cent. over the working range of the engine is often permissible. Variations as low as 1 per cent. of the mean engine speed may be obtained under favorable conditions.

215. There Are Two Principal Methods Used With Fly-Ball Governors For Controlling The Steam Admitted To An Engine: (1) *By throttling* (Figs. 252 and 253) or reducing the pressure in the steam chest of the engine by partly closing a valve in the live-steam line. With this method, the governor (Fig. 254) is not part of the valve-operating mechanism. This method of governing is used chiefly with simple slide-valve engines. (2) *By varying the cut-off*. Under this condition, the governor (Figs. 247, 255, and 256) is part of the valve gear. This method of governing is employed chiefly with Corliss and poppet-valve engines.

EXPLANATION.—Fig. 253 shows the effect on the indicator diagram of a slide-valve engine of a throttling governor such as that of Fig. 254. The line, *A*, represents the admission and expansion with a large governor-valve opening. *B* and *C* correspond to smaller governor-valve openings at lighter loads. It will be noted from the way in which the admission

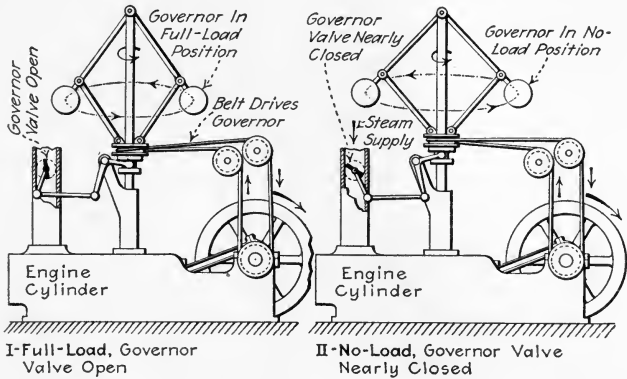

FIG. 252.—Diagram illustrating method of governing by throttling. (The diagrammatic construction shown above is never used.)

lines slope from points *R*, *S* and *T*, that there is considerable *throttling* (*wire drawing* or pressure drop due to friction) of the steam in the governor valve. This throttling results in loss in effective steam pressure (Sec. 14) and consequent poor economy especially at light loads. Fig. 256 shows the effect of a cut-off governor such as that shown in Fig. 247, on the

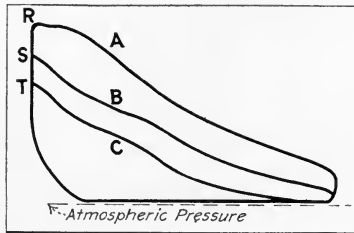

FIG. 253.—Indicator diagrams at various loads taken from an engine governed by throttling.

indicator diagrams of a Corliss engine. The cut-off occurs at *A*, *B*, *C* and *D* (Fig. 256) at various loads. The engine performance here shown is much superior to that in Fig. 253. The admission lines are nearly horizontal indicating that there is, at all loads, but little steam friction in the valves.

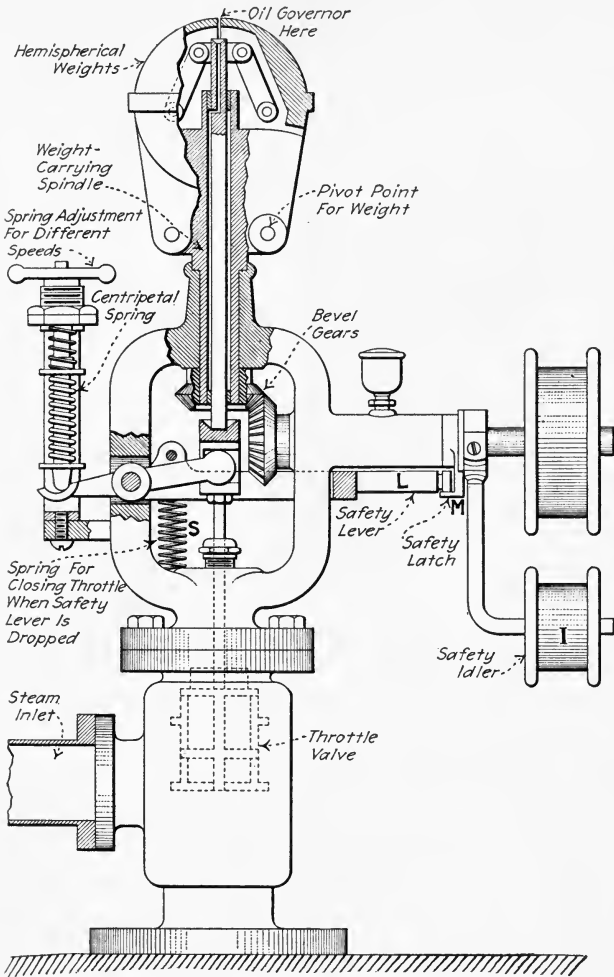

FIG. 254.—Erie pump governor. (This governor is used on pumping engines where, besides limiting the maximum engine speed, it must control the engine speed to meet the demands of the pump. That is, if less pumping is required, the governor diminishes the engine speed. Thus, it will control the engine at speeds of 80 to 320 r.p.m., depending upon the demand. If the belt breaks, the idler, *I*, drops allowing the valve to be closed by the spring, *S*, through the safety latch, *M*, and lever, *L*.)

216. A Steam-Engine Governor Should Be Designed And Maintained For The Greatest Possible Safety And Reliability.

A "safety stop" should be provided in every case. Belt-

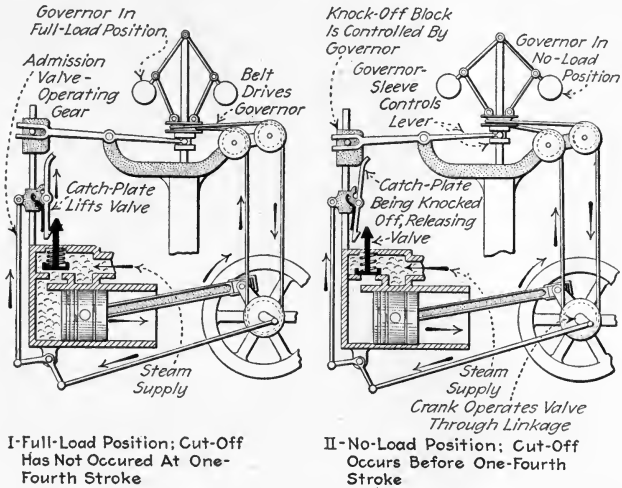

FIG. 255.—Diagram illustrating method of governing by varying the cut-off. (The "knock-off" principle illustrated above is employed extensively in the Corliss governing mechanism; but the diagrammatic simplified construction shown above is never used.)

driven governors are commonly provided with safety idlers (I, Figs. 254 and 257) so that, if the belt breaks, the idler will drop and shut the governor valve. Corliss governors (Fig. 247)

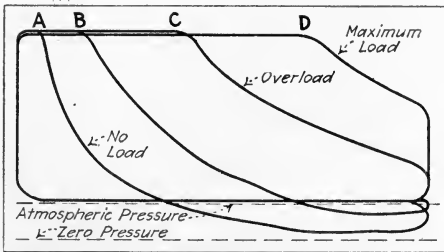

FIG. 256.—Indicator diagrams taken at various loads from engine governed by changing cut-off.

are provided with safety knock-off cams, C, so that, in case the governor drive fails and the balls drop, the intake valves will admit no steam to the engine. Various arrangements

(Fig. 258) are provided for holding the governor out of the safety position while starting the engine. Whatever arrangement is used, it must be so designed that it will fall out of the way automatically as soon as the governor lifts (Fig. 258). The engineer's memory should not be trusted to remove the starting cam or lever. Pins (*P*, Fig. 259), which must be removed by hand after starting, should not be tolerated.

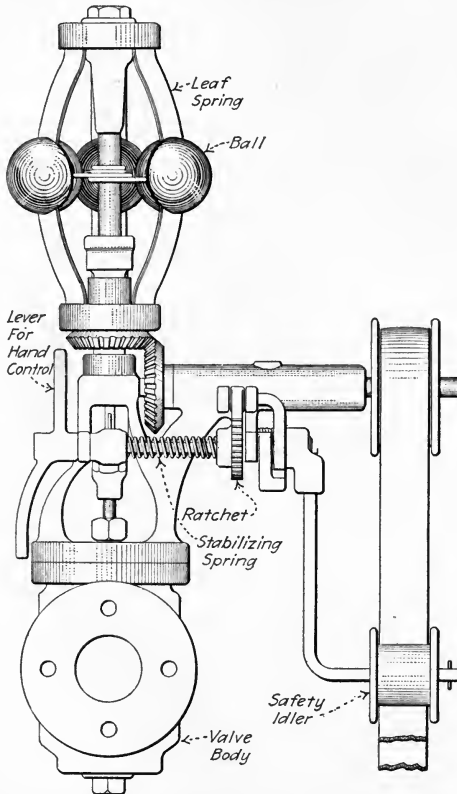

FIG. 257.—Elevation of Pickering governor showing safety idler feature.

NOTE.—MANY ENGINES AND POWER PLANTS HAVE BEEN WRECKED DUE TO GOVERNOR FAILURES. If the governor does not shut off nearly all the steam when the load is taken off the engine, the engine speed may become great enough to burst the flywheel by centrifugal force. Sometimes a "secondary safety stop" (Fig. 260) is installed in addition to the one with which the governor is regularly equipped.

NOTE.—AN ENGINE, WHICH IS EQUIPPED WITH A SAFETY DEVICE, MAY STOP WHEN AN EXCESSIVELY HEAVY LOAD IS THROWN ON IT (W. H. Wakeman in *Power*). In almost all makes of Corliss engine

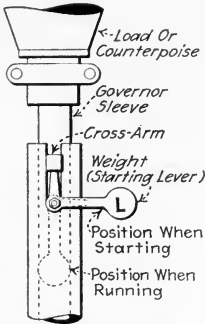

FIG. 258.—Showing starting lever, *L*, which falls out of position when the governor lifts.

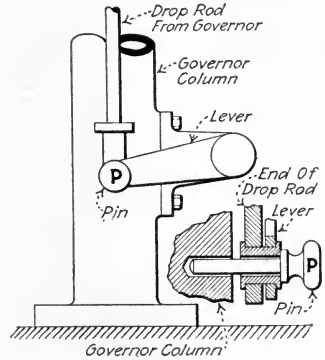

FIG. 259.—Showing unsatisfactory pin arrangement for holding Corliss governor in starting position. This arrangement is unsafe.

governors there is the "safety pin" on which the weights are brought to rest when the mechanism is not in action. Or instead a "safety collar" may be used. Both of these devices prevent the mechanism from falling

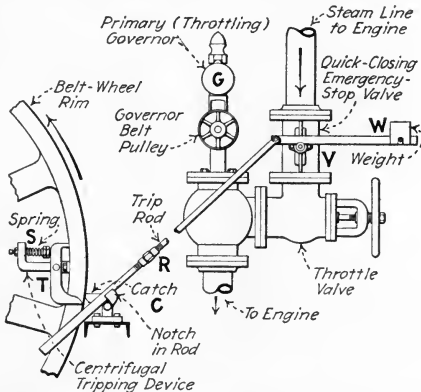

FIG. 260.—Detail of the design of trigger device for secondary speed control on Chandler & Taylor variable-speed engines. (If speed becomes excessive, *T* is thrown outward by centrifugal force, compressing *S*. Thereby *C* is tripped which releases *R*. Then *W* falls down and closes *V* which shuts off steam to the engine.)

so low that no steam will be admitted. These pins, or collars, are so placed that, when it is at rest, the engine will get steam. When the engine is in full operation, the pin is removed or the collar so turned that,

should the belt or gear break, the governor mechanism will drop so low as to cut off all steam and a shut-down results. In plants where heavy and changing loads are handled, it is not uncommon for a sudden load to be imposed on the engine, which is so great as to make the mechanism drop low enough to shut off steam, if the operator has attended to his duty of removing the pin or setting the safety collar after starting up. The result is a shut-down. This may confuse the inexperienced operator until he knows the cause. Always look at the "safety" when an unusual shut-down occurs.

NOTE.—SOME GOVERNOR PULLEYS ARE SECURED TO THE SHAFT WITH A SET-SCREW WHICH MAY COME LOOSE, or a key may work loose. The pulley may hold just enough to slowly rotate the governor but not sufficiently to bring it up to speed. The result will be a runaway engine. An oily or slack governor belt may also cause this.

217. Only The Best And Safest Materials And Methods Should Be Used In The Construction Of Governor Mechanisms.

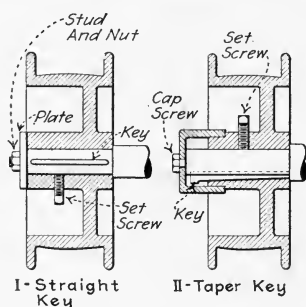

FIG. 261.—Showing methods of securing governor pulleys.

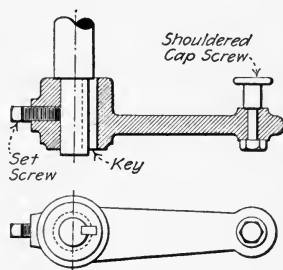

FIG. 262.—Showing a method of securing a governor lever.

The cost of these materials and methods is comparatively small, whereas the damage done, if the governor fails, may be very large. *Governor belts* should be of the best grade and be so sewed and cemented as to be practically endless. They should be of even weight and not wide enough to rub on the flanges of the governor pulleys. Governor pulleys should preferably be of metal and secured with more than a single set-screw. Pulley faces and belts should be kept free of oil which might cause slipping. Recommended fastenings for governor pulleys and levers are shown in Figs. 261 and 262.

218. Dangers Due To The Binding Of A Governor Mechanism Should Be Carefully Avoided.—The pivots of governor

rods should have sufficient end play (*E*, Fig. 263) to prevent binding caused by slight frame movements or by grit getting between the end faces. The governor, if new or if it has been

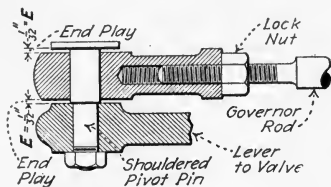

FIG. 263.—Showing proper end-play for governor-rod pivots.

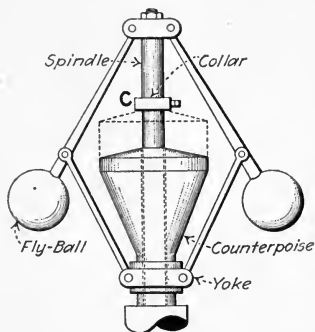

FIG. 264.—A collar which limits the lift of a fly-ball governor should never be allowed to get too low.

out of use for some time, should be moved by hand before starting to insure that it does not bind. Collars (*C*, Fig. 264) must not limit the movement of the governor so as to prevent

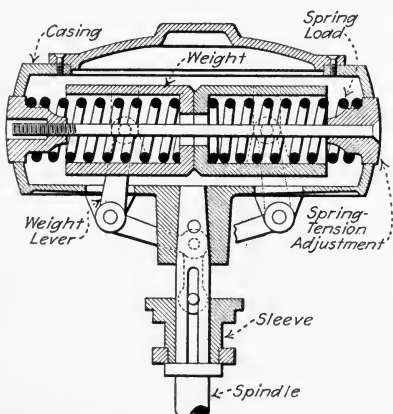

FIG. 265.—Enclosed-spring governor. (From Hamkens, STEAM ENGINE TROUBLES.)

its completely shutting off the steam supply. Enclosed parts (such as dash-pots, Sec. 230, and enclosed springs, Fig. 265) should be inspected regularly. Oil should occasionally be drained from dash-pots and the pots refilled with clean

oil. The pots should be kept well filled with oil as pocketed air is likely to cause dangerous racing.

219. Various Terms Used To Describe The Performance Of A Governor may be defined as follows: (1) By *sensitiveness* is meant the ability of a governor to substantially vary the amount of steam admitted to the engine in response to *slight* changes in engine speed. Sensitiveness is not an exact term (see below). (2) By *powerfulness* of a governor is meant the force which the rotating parts of the governor are capable of exerting on the governor rods or other steam-controlling mechanism when a variation in speed occurs. If a governor is to be very sensitive, and very powerful, it must be very large or run at a high speed. (3) *Promptness* is the ability of the governor to respond quickly to load changes. A very prompt governor is one which requires only a fraction of a second to adjust itself to a considerable change in load. (4) *Sluggishness* is the opposite of promptness. A governor which requires a half minute or more to adjust itself to a new load is relatively "sluggish." To be very prompt, a fly-ball governor must not be heavy. (5) *Coefficient of regulation*, also called *regulation*, *coefficient of speed regulation*, *speed variation or fluctuation*, is the variation in speed which the governor permits from no load to full load expressed as a percentage of the full-load speed. The coefficient of regulation is an exact mathematical measure of *sensitiveness*. Expressing this relation by a formula:

$$(25) \quad M_r = \frac{N_n - N_f}{N_f} \quad (\text{decimal})$$

Wherein: M_r = the regulation coefficient, expressed decimally. N_n = speed of the engine at no load, in revolutions per minute. N_f = speed of the engine at full load, in revolutions per minute.

EXAMPLE.—An engine manufacturer guarantees a regulation coefficient of 1.5 per cent. for his engine equipped with a certain governor. The engine makes 178 r.p.m. at no load and 175.7 r.p.m. at full load. Is it within the guarantee? SOLUTION.—By For. (1) the coefficient of regulation, $M_r = (N_n - N_f)/N_f = (178 - 175.7) \div 175.7 = 0.0141 = 1.41$ per cent. The engine is within the guarantee.

NOTE.—IN CONDUCTING REGULATION GUARANTEE TESTS, it is usually understood that the change from no load to full load is to be made gradually. But “specifications should clearly state the method to be employed in determining the speed variation and basis upon which the calculations are to be made. This is particularly important when the unit is supplying both a lighting and rapidly fluctuating motor load, as in this case the instantaneous variation of speed must be limited to a small margin to prevent ‘blinking’ of the lights. For high-speed direct-connected units the U. S. Treasury Department specifies that the maximum variation in speed for a slow change in load from no load to full load or vice versa shall not exceed $1\frac{1}{2}$ per cent. of the speed at full or normal load, and that for sudden change in load the maximum variation shall not exceed 2 per cent.” (From Harding and Willard, MECHANICAL EQUIPMENT OF BUILDINGS.)

220. Some Descriptive Terms Applied To Fly-Ball Governors which should be understood are: (1) A *stable or static governor* is one which occupies a definite position at a definite speed. A governor is stable when the resistance to motion (centripetal force) changes faster, as the balls assume different positions, than does the centrifugal force which the balls develop. (2) An *unstable or astatic governor* is one in which a slight increase or decrease in speed will cause it to move to one or the other extreme position. If the restraining (or centripetal) force changes more slowly than the centrifugal force, a governor is unstable. (3) A *neutral or isochronous governor* is one which, at a certain speed, assumes, indifferently, any position throughout its range. If the centrifugal force and the centripetal force change at the same rate, the governor is neutral or isochronous.

NOTE.—AN UNSTABLE GOVERNOR IS QUITE USELESS FOR ENGINEERING PURPOSES. Such a governor would always be either in full-load position or shut off entirely. Governors are frequently called “isochronous” (which means equal speed) when they are not truly so. A truly isochronous governor would also be useless for engineering because it would change in position as much for a slight change in load as it would for a large one. The aim in governor design should be to make the governor stable but very nearly neutral, that is, to make it as nearly isochronous as is feasible. Such a governor gives smaller speed variation than does a very stable governor.

221. The Action Of Centrifugal Force In Actuating A Governor is considered in Secs. 222 and 224. While a knowl-

edge of these principles is of interest to the practical man, it is not probable that he will ever have to apply them in adjusting or maintaining an engine governor. However, a knowledge of these principles and their application is essential to the governor designer.

222. To Compute The Centrifugal Force Developed In A Revolving Governor Weight, use the following formula:

$$(26) \quad F_c = 0.000,028,5W r_i N^2 \quad (\text{pounds})$$

Wherein: F_c = the centrifugal force, in pounds, developed by the weight. W = the weight of the governor ball, in pounds.

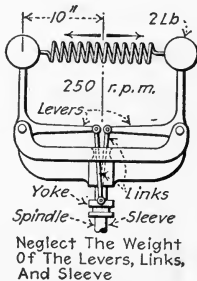

FIG. 266.—How much tension is there in the spring?

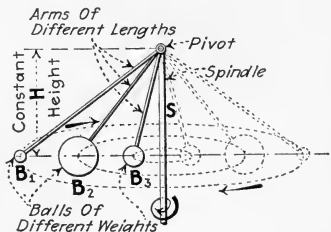

FIG. 267.—Showing constant height to which governor balls will rise at a certain speed.

N = the speed of the governor, in revolutions per minute.
 r_i = the radius from the center of gravity of the weight to the axis of rotation (center of the spindle), in inches.

EXAMPLE.—Assume that the balls of the governor (Fig. 266) weigh 2 lb. each and are 10 in. from the center of the spindle when they are revolving at 250 r.p.m. What centrifugal force will they exert on the spring under these conditions? **SOLUTION.**—By For. (26), the centrifugal force in each ball equals the tension on the spring, or: $F_c = 0.000,028,5W r_i N^2 = 0.000,028,5 \times 2 \times 10 \times (250)^2 = 35.6 \text{ lb.}$

223. The Theoretical Vertical Distance Between The Center Of The Balls And The Pivot Of The Arms In A Simple Pendulum Governor Depends On The Angular Speed And Is Independent Of All Other Factors.—Assume that three balls, B_1 , B_2 and B_3 (Fig. 267), of different weights are suspended by arms of different lengths and caused to make the same number of revolutions per minute about a common spindle, S . The vertical height, H , will be the same for all three regardless of the

weights of the balls and lengths of the arms. The statements of this section are true only for an ideal governor mechanism which has weightless arms and which has nothing to lift when it operates. If the governor balls must, when they rise, lift a weight other than their own then they will not rise as far as they would rise if unweighted. See Sec. 225 for effects of weighting.

224. To Compute The Theoretical Height To Which The Balls Of An Ideal Simple Pendulum Governor Will Rise At A Given Speed, use the following formula:

$$(27) \quad L_{hi} = \frac{35,200}{N^2} \quad (\text{inches})$$

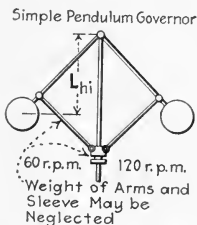

FIG. 268.—How high will the balls rise?

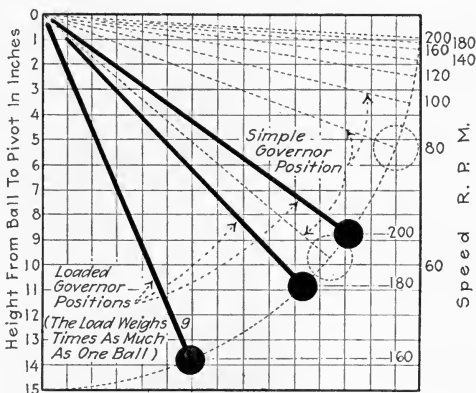

FIG. 269.—Showing theoretical positions of balls of simple and of loaded governors at different speeds. (Arms are assumed to be weightless. The balls lift nothing but themselves and, if specified, a centrally attached load.)

Wherein: L_{hi} = the height, in inches, from the center of gravity of the balls to the pivot of a simple pendulum governor. N = the speed of the governor, in revolutions per minute.

EXAMPLE.—Compute the height from the center of gravity of the balls to the pivot of the governor balls shown in Fig. 268 when it is revolving at 60 r.p.m.; at 120 r.p.m. **SOLUTION.**—By For. (27), the height, $L_{hi} = 35,200/N^2 = 35,200 \div 3,600 = 9.8 \text{ in. at } 60 \text{ r.p.m.}$ $L_{hi} = 35,200 \div 14,400 = 2.44 \text{ in. at } 120 \text{ r.p.m.}$

NOTE.—THE SIMPLE PENDULUM GOVERNOR MUST RUN AT LOW SPEEDS since the balls would fly out to a nearly horizontal position at high speeds

and would then change very little in position while the speed varied greatly; that this is true is evident from the preceding example. Fig. 269 shows the theoretical angular positions of a simple-pendulum-governor arm at different speeds. The practical speed limit for simple-pendulum governors is about 125 r.p.m. while speeds of 600 r.p.m. and over are used in spring-loaded fly-ball steam engine governors. Actual governor balls do not ordinarily rise as high as indicated by Fig. 269 because of the restraining gravitational forces of the mechanisms or weights which must be lifted by the balls.

225. Nearly All Modern Fly-Ball Governors Are Weight- Or Spring-Loaded.—Hence they will not rise to the theoretical heights given by For. (27.) Watt's unloaded governor (Fig. 249) was satisfactory for slow-speed engines which did not require close speed regulation, but for most modern requirements, it is unsatisfactory. Fig. 270 shows various methods of applying a weight load,

W, or counterpoise to a fly-ball governor. In all of these methods the weight is so arranged that it will slide on the spindle and revolve with the spindle and balls. The weight, in all cases, opposes the tendency of the balls to fly apart. These arrangements give more accurate regulation than can be obtained with an unloaded governor because, with them, a small change in engine speed can be made to cause a large change in governor position (Fig. 269).

226. The Advantages Of The Spring- Or Weight-Loaded Governor Over The Simple Pendulum Governor may be enumerated as follows: (1) *It increases the range of speed* between maximum and minimum governor positions (2) *It affords closer regulation* by increasing the vertical movement (Fig. 269) for a given change in speed. (3) *It decreases the sluggishness* of the governor by making it possible to employ light-weight balls. (4) *It increases the sensitiveness* of the governor by furnishing an effective means of offsetting frictional resistances. The governor is made more powerful

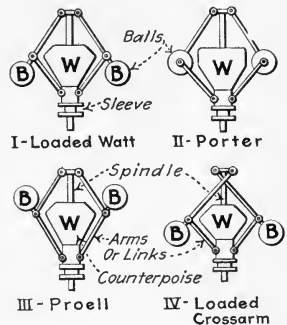

FIG. 270.—Various arrangements used in applying a weight load or counterpoise to a governor. *W* = weight or counterpoise. *B* = fly-ball.

and, thus, more easily overcomes frictional resistances in its own mechanism.

227. The Following Formula Expresses The Relation, For A Porter Governor, Between Speed, Height, And Weights Of Balls And Counterpoise.—This formula assumes that the four arms of the governor are of equal length.

$$(28) \quad L_{hi} = \frac{W + W_1}{W} \times \frac{35,200}{N^2} \quad (\text{inches})$$

Wherein: L_{hi} = the height (L_{hi} , Fig. 271) from the center of, the balls to the intersection of the arm and spindle axes, in inches. W = the weight of one of the two balls, in pounds. W_1 = the weight of the central load or counterpoise, in pounds. N = the speed of the governor, in revolutions per minute.

EXAMPLE.—What does the counterpoise of a Porter governor (Fig. 271) weigh if the balls weigh 8.3 lb. each and the height is 13 in. at 325 r.p.m.?

SOLUTION.—Substituting in For. (28), there results: $13 = [(8.3 + W_1) \div 8.3] \times 35,200 \div (325)^2$, from which $W_1 + 8.3 = 323.7$ or $W_1 = 315$ lb.

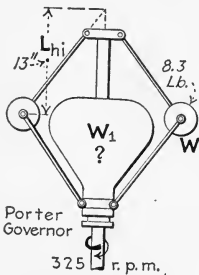

FIG. 271.—How much does the central load or counterpoise weigh?

NOTE.—THE RELATIONS OF FORCES, WEIGHTS AND SPEEDS IN FLY-BALL GOVERNORS are indicated in the following items. The matters of rates of increase and decrease of centrifugal and centripetal forces in governors of various types in various positions will not be discussed in detail in this book since they involve higher mathematics and are of interest principally to governor designers. Also the methods of analyzing the forces in a governor (as used in the above example) will not be explained for somewhat the same reason.

(1) The lifting forces exerted by governor balls in a loaded governor are usually many times greater than the weights of the balls.

(2) The centrifugal force of the balls is proportional to the weight of the balls, to the distance of the balls from the spindle and to the square of the speed; see For. (26).

(3) The faster a given set of governor balls revolves, the greater must be the load applied to balance them.

(4) The greater the load for a given set of balls, the more powerful (Sec. 219) the governor, provided it goes fast enough to lift the load.

(5) Other things being equal, a high-speed heavily-loaded governor is more prompt and more sensitive than a low-speed one.

(6) All weight-loaded governors of the types shown in Fig. 270 are stable except the cross-arm type which may be so designed as to be unstable or astatic. Extra attachments may be added to any governor so as to lessen or increase its stability.

(7) Governors of the types shown in Fig. 270 become less powerful and sensitive as their arms approach nearly-horizontal positions.

(8) The smaller the speed regulation, the less powerful will be a given set of governor weights or balls revolving at a given speed.

228. Spring-Loaded Governors May Secure Close Regulation And Are, In General, More Prompt Than Weight-Loaded Governors.—The inertia of a spring is negligible and so only the inertia of the weights and arms need be

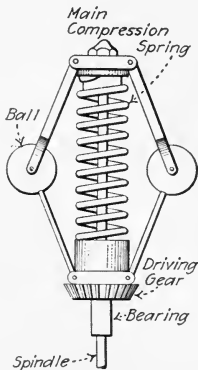

FIG. 272.—Spring arrangement used in the Gardner throttling governor.

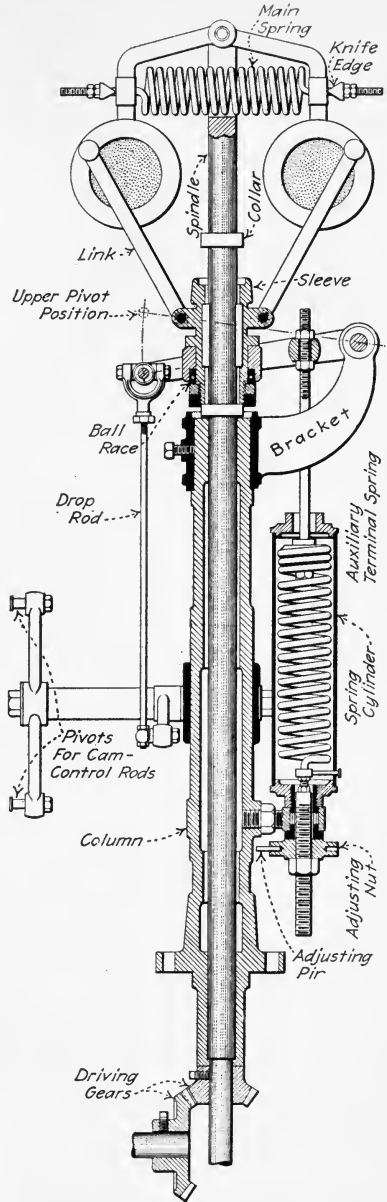

FIG. 273.—General arrangement of No. 7 open Tolle governor. (Vilter Mfg. Co., Milwaukee, Wis.)

overcome when a spring-loaded governor changes position. With a given governor design, a stiffer spring slightly compressed gives a more stable and prompt (but less sensitive) governor than does a weaker (more flexible) spring more heavily compressed. A spring-loaded governor is usually stable because the resistance of a spring rapidly increases as the force on it is increased. Figs. 257, 265, 272, and 273 show various arrangements by which spring loads may be applied to fly-ball governors.

229. A Governor Which Has Small Speed Regulation Must Be Provided With Some Means Of Preventing "Hunt-

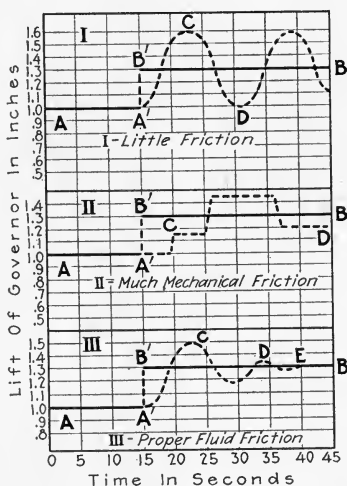

FIG. 274.—Showing characteristic "Hunting" graphs of governors.

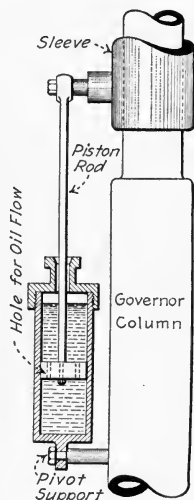

FIG. 275.—Non-adjustable governor dash-pot filled with oil.

ing."—A governor hunts when, in changing from one load to another, it has a tendency to go too far due to the momentum of its parts.

EXPLANATION.—Fig. 274-I shows the "hunting" of a very free-moving governor when the load changes suddenly. Assume that the governor was steady in position AA' for a certain load and that the load changes so that the governor should, for equilibrium, assume some new position $B'B$. The governor responds but the momentum of its parts carries it past the proper position to C and then back to D . This action may

cause the engine to pull unevenly and the "hunting" may then be further increased. Graph *II* shows the effect of much mechanical friction on the governor action. The governor then hunts very violently and in "jerks" but the action may be very uncertain and cause much variation in engine speed. Graph *III* shows the effect of fluid friction introduced by means of a properly adjusted dash-pot (Figs. 275 and 276). The governor tends to follow graph *I* (Fig. 274) but the fluid friction in the dash-pot prevents its so doing. The governor soon comes to rest at *E*. Fluid friction prevents rapid movement but offers practically no resistance to very slow motion. This friction therefore prevents "hunting" and sudden movements but does not materially decrease the accuracy of the the governor.

230. A Dash-Pot Or Gaggot (Figs. 275 and 276) is usually used to limit the rate at which a cut-off governor may move. The valve of a throttling governor has a stabilizing (or damping) effect so that a dash-pot is not ordinarily necessary with governors of the throttling type. The dash-pot consists (Fig. 276) of a cylinder *C* filled with oil; a piston *P*, and rod *R* and means such as pipe *B* for allowing oil to flow around the piston at the proper rate. Simple non-adjustable dash-pots (Fig. 275) have holes for allowing oil to pass through the piston. Movable plates are sometimes placed over these holes and controlled by a nut on the piston rod. A pet-cock is usually provided for draining and a hole for filling. If the dash-pot piston rod is directly connected to a lever, as in Fig. 250, the dash-pot cylinder should be so mounted on a pivot such as *L* (Fig. 276) that it will always line up with the lever pivot as the lever swings. If the rod is connected through a spring (Fig. 277), or if the piston is designed as shown in Fig. 288, the cylinder may be rigidly mounted.

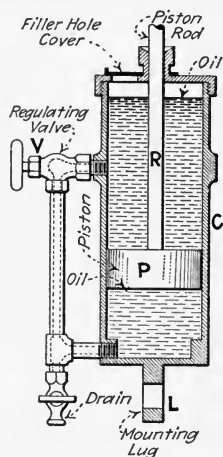

FIG. 276.—Dash-pot adjustable by valve, *V*, on outside.

NOTE.—THE SIZE OF DASH-POT REQUIRED FOR A GOVERNOR VARIES with the load conditions. Ten square inches per 100 engine horse power is ordinarily ample where the dash-pot stroke is about equal to its bore. Common machine oil is usually used in dash pots. It may be

thinned with kerosine if too thick. Cylinder oil or glycerine may be used if a thicker liquid is required.

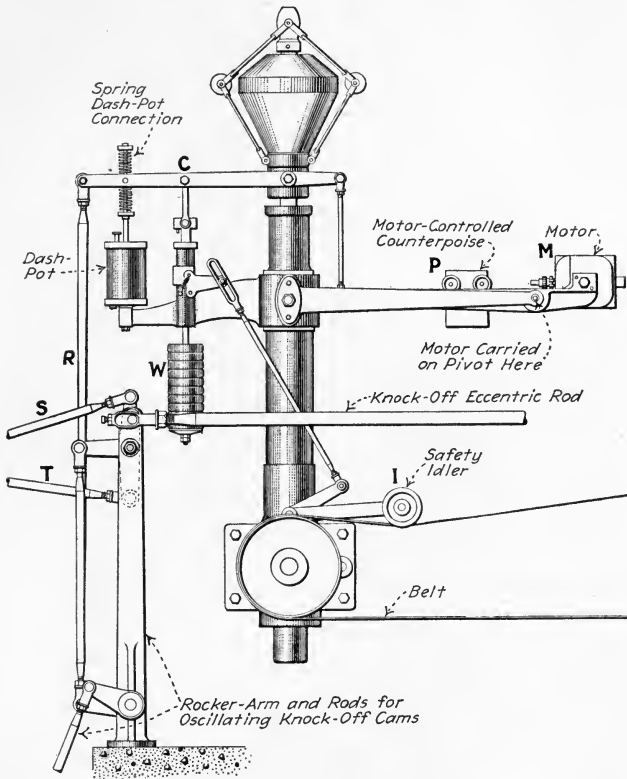

FIG. 277.—Nordberg governor showing spring-connected dash-pot rod. (If the safety idler, *I*, drops due to failure of the belt, the weights, *W*, will be released and the pivot, *C*, will be dropped. This will operate the rods, *R*, *S* and *T*, so as to stop the engine. When the engine is driving an a.c. generator, the motor, *M*, is, when synchronizing the generator with another generator, so controlled by the operator at the electrical switch-board that the weight, *P*, is shifted to such a position that the engine speed is changed to the proper one to permit synchronizing. After the machines have been synchronized, the load may be properly divided between the two engines by the operation of *M*.

231. Governors May Be Adjusted To Change Engine Speed In Several Ways.—(1) *Weight may be added or removed.* Provision is often made for adding or removing weight (Figs. 277, 278 and 279). A weight may sometimes be adjusted in or out on a lever arm (*W*, Fig. 280). Increasing

the leverage or the weight, where the weight opposes the rise of the governor, increases the engine and governor speed and vice versa. To compute even approximately the amount of weight which should be added or deducted in any given case usually involves complicated calculations and a knowledge of the weights of each of the moving parts of the governor; see note under Sec. 227. Hence,

in practice, the most direct method of finding the necessary amount of weight is by trial. (2) *Increasing or decreasing spring tension or adding an extra spring* changes the engine speed. Most spring-loaded governors (Figs. 254, 265 and 273) have adjustments for this purpose. When they do not, an extra spring (Fig. 281) may be added. Increasing the spring tension increases engine speed. (3) *A take-up adjustment may be provided in the governor mechanism* (Figs. 282 and 283). Increasing the effective length of the linkage in such adjustments ordinarily decreases the engine speed. In increasing the engine speed by this method when a Corliss governor is used, make sure that the governor will shut off completely after the adjustment is made. The collar on the governor spindle may have to be raised to permit this. It is dangerous to make the cut-off later for a given governor position without testing afterward to make sure the governor will shut off. (4) *Increasing the weight of the balls of a loaded governor* decreases the engine speed. (5) *The pulley or gear sizes may be changed to drive the governor at a different speed relative to the engine speed.* That is, the governor continues to rotate at its original speed but the engine speed is either increased or decreased.

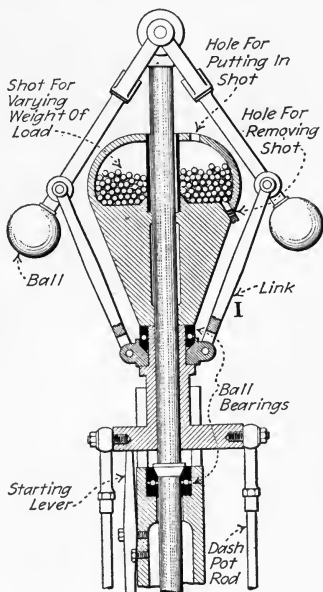

FIG. 278.—Governor which may be adjusted for different speeds by adding or removing weight (shot). (Murray Iron Works Co., Burlington, Iowa.)

will shut off completely after the adjustment is made. The collar on the governor spindle may have to be raised to permit this. It is dangerous to make the cut-off later for a given governor position without testing afterward to make sure the governor will shut off. (4) *Increasing the weight of the balls of a loaded governor* decreases the engine speed. (5) *The pulley or gear sizes may be changed to drive the governor at a different speed relative to the engine speed.* That is, the governor continues to rotate at its original speed but the engine speed is either increased or decreased.

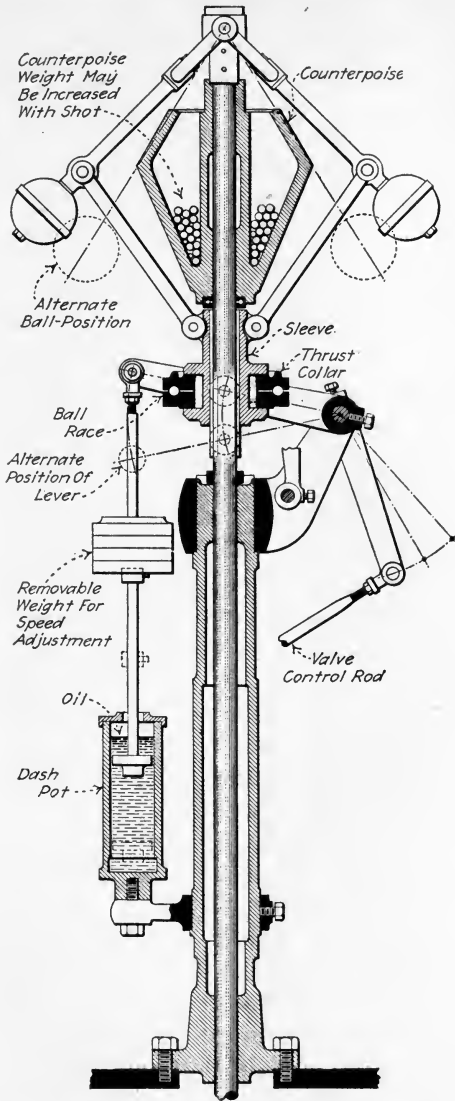

FIG. 279.—General arrangement of high-speed loaded Watt governor No. 2. (Vilter Mfg. Co., Milwaukee, Wis.)

If the governor driving pulley—on the engine shaft—is increased in size, the engine speed will be proportionally decreased. If

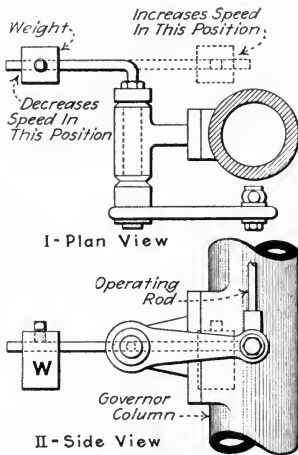

FIG. 280.—Showing weight which may be adjusted on lever to change the engine speed which is maintained by the governor.

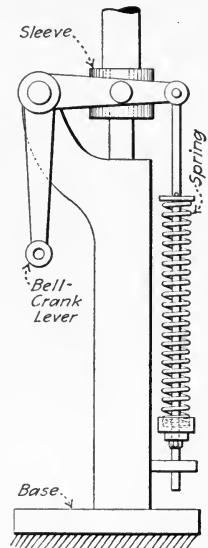

FIG. 281.—Extra spring added to vary the governed speed of an engine.

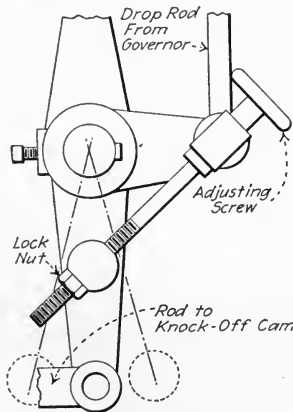

FIG. 282.—Showing speed adjustment provided in governor linkage.

the driven pulley or gear is increased in size, the speed of the engine will be proportionally increased and vice versa.

NOTE.—THE SENSITIVENESS OF A GOVERNOR IS OFTEN CHANGED ALSO WHEN THE SPEED IS CHANGED. Increasing the weight or spring tension has a tendency to make the governor more sensitive.

Many *paper-mill engine governors* are provided with double cone pulley drives so that the engine speed may be increased to 4 or 5 times the minimum speed by shifting the drive on the cones. Engines equipped with such governors are called *variable speed engines*.

NOTE.—THE SPEED AT WHICH ENGINE GOVERNORS SHOULD OPERATE IS SOMETIMES STAMPED ON THE GOVERNORS by the manufacturer of the engine. If it is not so stamped the correct operating speed should be ascertained from the manufacturer or by test before one attempts to change the engine speed.

EXAMPLE.—An engine (Fig. 284-I) which has a governor-driving pulley, *P*, 9 in. in diameter and a driven pulley, *D*, 12 in. in diameter is operating satisfactorily at 75 r.p.m. What change should be made in the governor drive so that the engine will operate at 65 r.p.m.?

SOLUTION.—For satisfactory operation, the governor should operate at the same speed—the same r.p.m. of the governor and its pulley—as before. With the engine speed decreased, the same governor speed may be maintained by changing either pulley *P* or pulley *D*; or by changing both pulleys *P* and *D*, and using new ones of properly selected diameters.

If pulley *P* is changed, its new diameter should be $9 \times 75 \div 65 = 10.3$ in. If pulley *D* is changed, the diameter for a 65-r.p.m. engine speed should be $12 \times 65 \div 75 = 10.4$ in. as shown in Fig. 284-II. With the decrease in engine speed, there will have to be a very slight

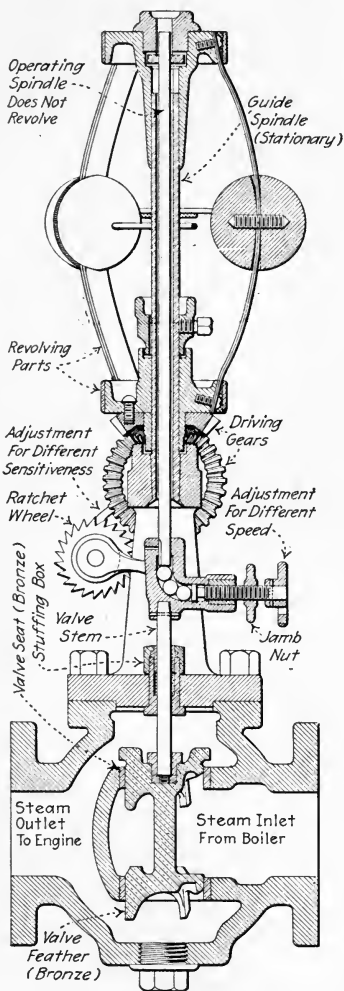

FIG. 283.—Vertical section of Pickering governor showing methods of adjustment.

decrease in the valve opening to maintain the lower speed, but this change in valve opening may, usually, be effected by an adjustment in the

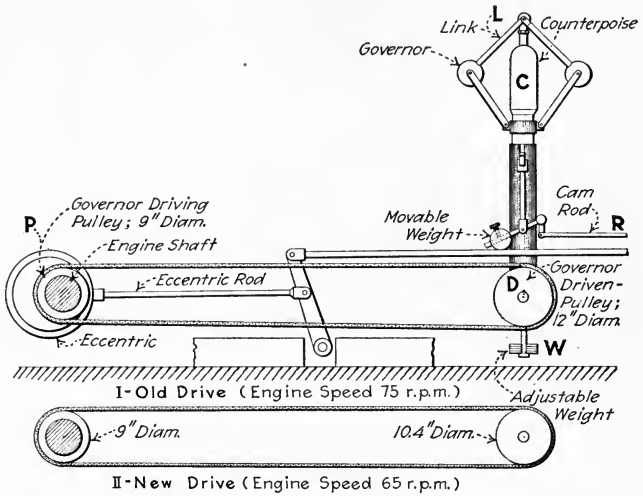

FIG. 284.—Example—changing governor-drive pulleys for a new engine-speed.

governor linkage. With the engine speed increased, the procedure would be the reverse of that just described.

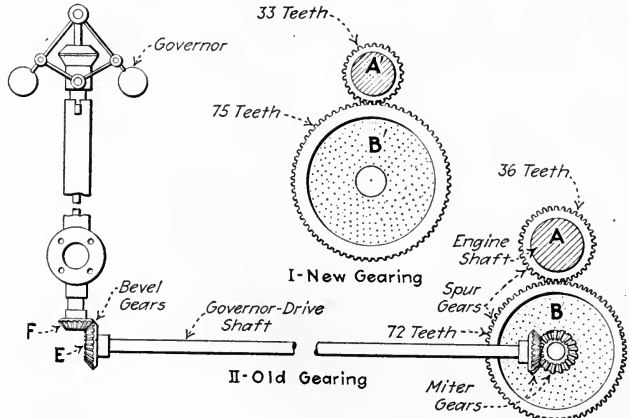

FIG. 285.—Example—changing either spur- or bevel-gear sizes for new engine-speed.

EXAMPLE.—If the governor in the preceding example had been gear driven (Fig. 285), the change in speed might have been made by changing

either the bevel gears, *E* and *F*, or the straight spur gears, *A* and *B*. In either case, assuming that the distance between the meshing gear centers must remain fixed, the two gears which mesh must both be changed. Assume that the gears, *A* and *B*, are 4 diametral pitch (that is, 4 teeth per inch of diameter) and have 36 and 72 teeth respectively. The pitch diameter of *A* is then 9 in. and that of *B* 18 in. The distance between centers must remain the same since the crank shaft and pinion shaft are both fixed. This distance is, in this case, $(9 \div 2) + (18 \div 2) = 13.5$ in. But for the change in speed required, the ratio must be changed in the proportion of 75 to 65 or it must now be $2 \times 75 \div 65 = 2.301$. If the same pitch is to be used, the total number of teeth in both gears must remain the same (108 teeth). The requirements for the new gears are then expressed by the equations:

$$\frac{M}{N} = 2.301 \text{ and } M + N = 108$$

Where *M* is the number of teeth in the new pulley, *B'*, and *N* is the number of teeth in the new pulley *A'*. Solving, by the simultaneous equation method, $M = 75.3$ and $N = 32.7$. Taking the nearest whole number of teeth which will give the required pitch diameters, there results: 33 and 75 for the required number of teeth. If the change is to be made in the bevel gears, a new pair must be designed or selected which will provide the desired ratio and the proper shaft alignments.

EXAMPLE.—Certain of the other means described in the above section for changing the speed of the engine of Fig. 284 are: (1) *If the counterpoise, C, is made lighter* it will decrease the speed of both the engine and governor; if it is made heavier, it will increase the speed of both engine and governor. (2) *Changing the weight W* has the same effect as changing *C* because the rod which supports *W* is connected to the spindle which carries *C*. Changing the weight, *W*, provides a convenient method of temporarily changing the speed of the engine. Thus, if a machine is being started which requires considerable power and which would normally slow down the overloaded engine, a weight of sufficient amount may be added to *W* to maintain, for the time being, the engine speed constant. Then, when the load of the machine is discontinued, the extra weight may be removed from *W*. This, as compared with the modern speed regulating devices is a crude expedient; but in emergencies it may prove serviceable. (3) *If the weight, D, is shifted backward or forward* on its lever, it will change slightly the speed of the engine. (4) *Some governors have at L a link of adjustable length* whereby the engine speed may be changed; see "Caution" below. (5) *The effective length of the cam rod, R, may be increased or decreased* to change the engine speed. *Caution:* But neither this plan nor the one just preceding it should, ordinarily, be adopted. Changes in *L* may affect the sensitiveness of the governor mechanism. Careless adjustment of either *L* or *R* may prevent the realization of a very short cut-off and thereby cause trouble—racing—if all of the engine's load is suddenly thrown off.

232. Governors May Be Adjusted For Greater Or Less Speed Regulation but such adjustments should, whenever possible, be referred to the manufacturer. The inexperienced engineer is cautioned against making radical adjustments of this sort. (1) Weight-loaded governors will give closer regulation if their speed is increased and enough dead weight added to bring the engine speed back to its original value. Conversely, if the speed is decreased and the dead weight lessened, there will be more variation in speed. (2) If a weaker spring is substituted in a spring-loaded governor and this

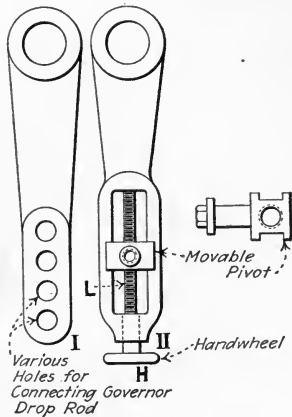

FIG. 286.—Showing adjustable governor levers. (Lever, I, is adjusted by changing the rod pivot from one hole to another. Lever II is adjusted by means of a hand wheel, H, and lead screw, L.)

spring is compressed more so as to exert the same force, the regulation will be closer because a lesser change in pressure in the spring will then be required to produce the same amount of movement. (3) The radius of a governor lever (Fig. 286) may be so adjusted that the same valve movement is accomplished with less governor movement.

NOTE.—AFTER MAKING ANY OF THE ABOVE ADJUSTMENTS FOR CLOSER SPEED REGULATION, there may be trouble with the governor hunting and the dash-pot resistance may have to be increased and perhaps a spring inserted in the dash-pot rod (Fig. 277) mechanism.

233. Some Governors May Be Adjusted For Greater Or Less Promptness, but these adjustments should ordinarily

be left to the governor designer and manufacturer. (1) Inertia effect may be introduced to secure quicker response but such a change ordinarily requires complete re-design of the governor. (2) Spring load may sometimes be substituted for part of the weight load in a weight-loaded governor. The spring is lighter and may change position more quickly than a weight. (3) A spring may sometimes, if not already used, be inserted in the dash-pot rod (Fig. 277). This spring allows the governor to assume its new position at once and

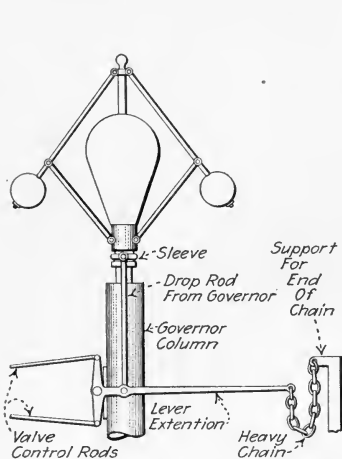

FIG. 287.—Chain recommended as substitute for the dash-pot for greater promptness. (C. E. Bascom in *Power*, June 29, 1915.)

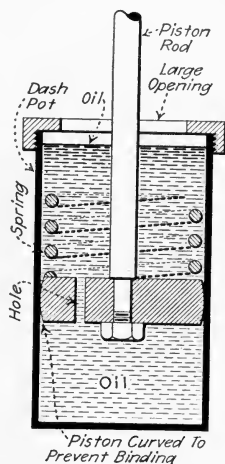

FIG. 288.—Spring inserted in dash-pot to retard the governor movement near the no-load position. Caution: If this device is used, the engine must be watched to insure that it will not race at light loads.

the dash-pot adjusts itself later. (4) A hanging chain (Fig. 287) has been recommended as a substitute for a dash-pot where greater promptness is desired. (5) A lighter oil or larger opening in the dash-pot gives greater promptness. A heavier oil or smaller opening in the dash-pot gives slower action—less promptness. (6) A spring may be inserted in the dash-pot, as shown in Fig. 288, if the engine is too prompt near no load.

234. Table Showing The Various Adjustments Of Fly-Ball Governors And Their Effects.

Part	Pulley or gear	Balls	Spring tension or weight load	Change weight for spring	Load and speed	Leverage	Take-up in linkage	Dash-pot
Change.....	Increase driving or decrease driven pulley or gear size	Increase weight of balls	Increase tension or load	Substitute weight load for all or part of spring load	Governor driven faster and more heavily loaded	Increase radius of lever attached to drop rod	Decrease valve opening for given governor position	Smaller opening or heavier oil
Main effect...	Decreases engine speed	Makes simple governor more powerful but more sluggish	Engine faster	Governor more sluggish	Governor more sensitive, engine speed may be the same	Governor less sensitive	Engine slower	Governor more sluggish
Other effects..		With loaded governor, engine slower, less sensitive	With weight load, governor slightly more sensitive	Less likely to vibrate	Governor more likely to hunt	Governor more powerful	Governor operating position different	Less likely to hunt
Change.....	Decrease driving or increase driven pulley or gear size	Decrease weight of balls	Decrease tension or load	Substitute spring for all or part of weight load	Governor driven slower and less heavily loaded	Decrease radius of lever attached to governor drop rod	Increase valve opening for given governor position	Larger opening or lighter oil
Main effect...	Increases engine speed	Makes simple governor less powerful, less sluggish	Engine slower	Governor more prompt	Governor less sensitive, engine speed may be the same	Governor more sensitive	Engine faster	Governor more prompt
Other effects..		With loaded governor, engine faster, governor more sensitive	With weight load, governor slightly less sensitive	More likely to vibrate	Governor more stable	Governor less powerful	Governor operating position different	More likely to hunt

235. Governors May, If Incorrectly Applied Or In Poor Condition, Allow Engines To Race for various reasons. By "racing" is meant the accidental running of an engine at considerably above the speed for which it was designed. (The following material is based partly on W. Trinks, GOVERNORS AND THE GOVERNING OF PRIME MOVERS.) (1) *If the racing takes place with an old governor* which has given several months or years of satisfactory service, the chief causes are:

(a) The dash-pot may be in poor condition or poorly adjusted. Air pockets in the dash-pot are likely to cause racing. If the oil opening in the piston or valve is too large, too sudden variation in governor position may be allowed. Under these conditions either the opening should be partly closed or a heavier oil used.

(b) The valves may have been adjusted so that the governor no longer properly controls them. If adjustments have been made in the valves, the governor linkage may have to be adjusted also. Racing from this cause usually occurs only at light loads, and is prevented by adjusting the governor linkage so that the valves may shut off completely at no load.

(c) There may be excessive friction somewhere in the mechanism. Such friction may usually be detected by moving the governor by hand either directly or with a bar, care being taken not to strain the apparatus. It may be caused by the framework of the governor becoming twisted out of line, in throttling governors by poor oil or dirt clogging the valve, or a number of other causes.

(d) The Corliss releasing gear controlled by the governor may be in poor condition. The knife edges may be so dulled that they slip and are uncertain in their action. The dash-pot of the valve may not close it completely when released. This latter trouble may be remedied temporarily by tying a long flexible spring to the dash-pot arm to assist the dash-pot in closing the valve. This, of course, is a makeshift and the dash-pot should be repaired as soon as possible.

(e) Where the governor is belt-driven, the belt may be slipping at times. Pressing down on the idler, or using a belt tightener, will indicate whether or not this is the trouble. When this occurs, either the belt is too loose or oily, or there is undue friction in the governor spindle bearings or gears.

(f) If the governor has been adjusted for a considerable change in speed, it may have been made unstable by the adjustment. It may be made more stable as indicated in Secs. 232 and 234, by adjusting for greater speed regulation.

(2) *If the racing occurs with a new governor* which has never given any satisfactory service, the trouble should, whenever possible, be referred to the manufacturer. New governors are

likely to be improperly adjusted to the load conditions (see Secs. 231 to 234). Racing of a new governor may be due to any of the causes given under old governors. In addition, there may be errors in the design or defects in the manufacture. Errors in design can sometimes be corrected by placing a spring in the dash-pot (Fig. 288) so that it will come into play in some particular position in which the governor does not behave properly.

NOTE.—MOST OF THE TROUBLES WHICH CAUSE RACING ALSO CAUSE SLACKING UP UNDER LOAD—that is, failure of the governor to increase the steam supply to meet increased load.

NOTE.—The proper adjustments of the Corliss engine governor mechanism are given in detail in Sec. 192.

236. The Principal Causes Of A Governor's Lagging Too Far Behind The Engine During Changes In Load are: (1) The

governor is too small or is not of a sufficiently prompt type for the load conditions. (2) The damping or retarding action of the dash-pot is too great. (3) The movement provided by the governor proper may be too small to operate the governing valve. (4) There may be friction in the mechanism which is slowly relieved by the vibration.

NOTE.—An adjustment for greater promptness (Sec. 233) will often remedy troubles (1), (2) and (3) above.

237. If The Governor Vibrates (Dances Or Jerks), The Causes Of The Trouble may be: (1) The

governor is too light, a more massive one should be used. (2) The damping action of the dash-pot is not sufficient. (3) The mechanism is mechanically poor and needs repair. (4) The belt may be poorly spliced so that the governor jumps as the splice goes over the pulley. A "load indicator" (Fig. 289) helps detect troubles of this sort.

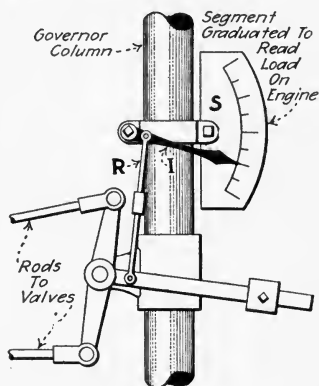

FIG. 289.—Homemade load indicator for engine governors. (The indicator hand, *I*, and segment, *S*, are made of wood or tin and installed, as shown, with an adjustable rod, *R*, and pins or bolts. The segment when marked correctly, shows at a glance, the load which the engine is delivering. It also assists in detecting "hunting" and jerking of the governor.)

NOTE.—HEATING, WEAR, POOR ALIGNMENT, WOBBLING, BUCKLING, etc., are likely to affect governor operation, just as they would that of any other mechanical device. Close adjustment and good action are not always possible where troubles of this sort are present. Another point to remember is that good governing is usually impossible when the engine valves are in poor condition.

238. In Ordering A Throttling Governor, the following questions should be answered (based on Pickering and Gardner governor catalogues): (1) What type or catalogue number is preferred? (2) Is the engine vertical or horizontal? (3) Diameter of engine piston? (4) Length of piston stroke? (5) What is the lowest speed required of the engine? (6) What is the highest speed required of the engine? (7) What is the class of service for which the engine is used? (8) Inside diameter and length of steam pipe? (9) Diameter of governor-driving pulley on engine shaft? (10) Width of belt driving governor? (11) What steam pressure is ordinarily carried? (12) Degree of superheat if any? (13) Is the flywheel on the engine large enough to keep the engine speed steady at all times?

239. The Following Table Gives The Sizes Of Throttling Governors ordinarily required (Jarecki Mfg. Co.—“Erie” governor):

Governor size, diameter of opening, inches	Engine cylinder diameters, inches			
	Piston speeds, feet per minute			
	300	400	500	600
1½	7	6	5	4½
2	9	8	7	6
2½	12	10	9	8
3	14	12	10	9
3½	16	14	12	11
4	18	16	14	13
4½	20	18	16	15
5	22	20	18	16
6	26	23	21	19
7	31	27	24	22
8	36	31	28	25
9	40	35	31	28
10	45	39	35	32

240. A Governor Once In Good Condition Requires The Following Attention.—Keep the governor clean and see that all oil holes are kept free. Use good oil. Pack valve-stem stuffing boxes of throttling governors with candle-wicking packing of good quality soaked in oil. Remove all old packing when re-packing. See that the valve stem is smooth and clean. Tighten the gland just enough to prevent escape of steam. For repair of governor valves see the author's STEAM POWER PLANT AUXILIARIES AND ACCESSORIES. Some engineers advise allowing a little steam to escape around the

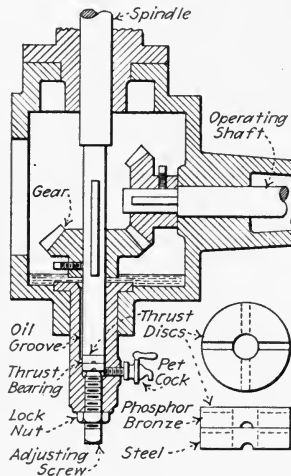

FIG. 290.—Showing adjustable thrust bearing for fly-ball governors.

stem to keep the packing lubricated and soft; and advise re-packing every 30 days. Changes in speed should, ordinarily, be made by methods recommended by the manufacturer. Belts must be tightened occasionally. Ball bearings (Fig. 278) must sometimes be renewed. Knife edges on sensitive governors (Fig. 273) will sometimes have to be sharpened. Thrust bearings (Fig. 290) occasionally need to be adjusted to make the gears mesh properly.

241. Compound Engines May Be Governed: (1) *By governing the high-pressure cylinder only.* (2) *By governing both cylinders.* The first method is used largely with small

engines and engines which are working under very steady loads. The cut-off of the low-pressure cylinder is then fixed at a point which will give a proper receiver pressure under the load expected. The objection to this method of governing is that it is too slow under most conditions since the changes in load are not compensated for in the low-pressure cylinder until the receiver pressure has changed. This change may require several strokes of the engine. It is an economical method of governing when it is applicable. When the second method is used, a mechanical connection is ordinarily made between the valve gears of the two cylinders so that a movement of the governor changes the cut-off on both cylinders proportionally. See Div. 8 for a further discussion of compound-engine governing.

QUESTIONS ON DIVISION 6

1. Why is a steam-engine governor usually necessary? When is one unnecessary?
2. Why does not a governor keep the engine speed exactly constant? What variations in engine speed do governors in practice permit?
3. What two forces are utilized by governors in detecting speed variations? Which is employed principally in fly-ball governors?
4. What two methods do fly-ball governors use for controlling the steam supply to the engine? Which gives the best engine performance? Why?
5. Show by a sketch one safety feature often used in throttling governors. One used in Corliss governors. What disaster may occur if the governor fails?
6. How should governor belts be spliced? Show by a sketch some extra fastenings which may be used on governor pulleys and levers.
7. Give some precautions which should be taken to lessen the danger of governor failure.
8. What is meant by a *sensitive* governor? One with small *coefficient of regulation*? A *prompt* governor? A *sluggish* governor? A *powerful* governor?
9. How are tests for speed regulation usually made? What bad effect results from momentary variation in speed of an engine driving a lighting generator?
10. Give four advantages of a loaded governor over a simple pendulum governor.
11. What is meant by a *stable* governor? An *isochronous* governor? Why cannot neutral and unstable governors be used in engineering?
12. On what does the centrifugal force in a revolving weight depend?
13. Explain by a sketch how balls hung from different length arms rise to the same height when revolved at the same speed.
14. State some relations between forces, weights and speeds in fly-ball governors.
15. What advantage has a spring-loaded governor over a weight-loaded one?
16. Explain with a graph the hunting of a governor after a sudden change in load.
17. What difference is there in the effect of fluid friction and mechanical friction on governor operation? What liquids are frequently used in dash-pots?
18. Describe the action of an adjustable dash-pot.
19. Name four methods of adjusting governors for different engine speeds. What speed adjustment (Table 234) has no other effect? How may a governor be adjusted for less speed regulation?
20. What is the danger of adjusting a governor for too little speed regulation?
21. How may a governor be adjusted for greater or less promptness?

22. Give some of the principal causes of racing and their remedies.
23. What will cause a governor to respond too slowly to a change in load on the engine? By what general method may this be overcome?
24. What will cause a governor to vibrate?
25. Name thirteen points of information which should be given in ordering a throttling governor.
26. What size throttling governor is required for an engine running 500 ft. per min. piston speed, having a bore of 14 in., under average conditions?
27. What care does a governor usually require after it has once been put in good condition?
28. What are the advantages of the two methods of governing compound engines?

PROBLEMS ON DIVISION 6

1. What is the coefficient of regulation of a governor if the engine runs 201 r.p.m. at no load and 197 r.p.m. at full load?
2. To what height from the upper pivot will the balls of a simple pendulum governor rise at 87 r.p.m.?
3. What centrifugal force will be developed in a governor ball weighing 6.25 lb. revolving at 500 r.p.m. at a radius of 4.32 in.?
4. A governor makes 3.7 revolutions for each revolution of the engine, the engine running at 105 r.p.m. How many revolutions should the governor make per revolution of the engine if the governor is to be adjusted by changing the pulley sizes to allow the engine to run at 125 r.p.m. If the adjustment is to be made by changing the governor-driving pulley on the crank shaft, which was previously 14 in. in diameter, what size pulley should be substituted?
5. The counterpoise on a Porter governor weighs 145 lb. and the weights 12 lb. each. If the height from the center of the ball to the intersection of the arm and spindle axes is 16 in. in starting position, at what speed will the governor lift?

DIVISION 7

SHAFT STEAM-ENGINE GOVERNORS, PRINCIPLES AND ADJUSTMENTS

242. A Shaft Steam-Engine Governor Is One Which Revolves About The Engine Crank Shaft As A Center.—A shaft governor is (Fig. 291) commonly located in the flywheel of the engine and governs the engine, as will be explained later, by changing the position of the eccentric or the valve-operating crank. Shaft governors are widely used on medium and high-speed engines (150 to 400 r.p.m. depending on the size; see also Secs. 74 and 75) of the slide-valve, poppet-

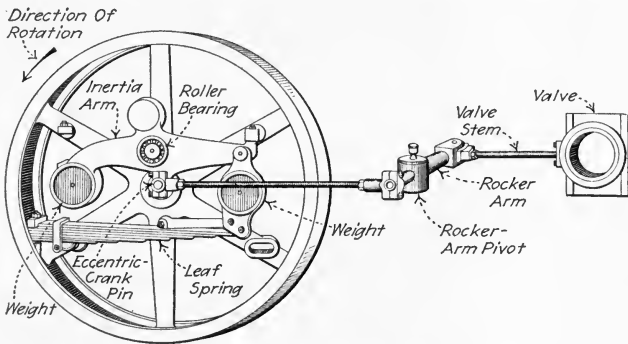

FIG. 291.—Skinner engine-governing mechanism.

valve and non-releasing Corliss-valve types and are adapted to service where sudden large changes in load occur and where close regulation is desired. Single-valve engines which are equipped with shaft governors are often called *automatic engines*. Shaft governors are sometimes called *automatic cut-off governors*.

NOTE.—ALL SHAFT GOVERNORS ARE “VARIABLE CUT-OFF” GOVERNORS. Their action is therefore superior to that of throttling governors

insofar as economy is concerned. However, a shaft-governed simple slide-valve engine does not show as good an economy as does a fly-ball-governed Corliss-valve engine. Fig. 292 shows the governing action of the Skinner engine governor (Fig. 291). The line *A* corresponds to a little more than friction load; the line *B* to about normal load; and the line *C* to maximum load. It will be noted that the cut-off is less sharp and the expansion lines less regular than with a Corliss gear (Fig. 256). Also there is more throttling at light loads with a shaft-governor cut-off gear than with a Corliss releasing gear. Furthermore, the compression line is changed (Fig. 292) with the shaft governed engine whereas it is not changed with the releasing Corliss engine.

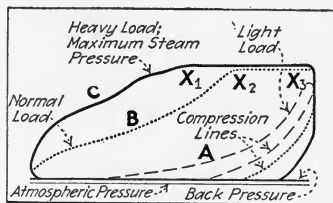

FIG. 292.—Showing the effect of variable cut-off governing by a shaft governor. (Cutoff occurs at X_1 , X_2 , X_3 .)

243. The Fundamental Principles And Terms Relating To Fly-Ball Governors (Div. 6) Apply Also To Shaft Governors.

For example, shaft governors may be stable, unstable, may allow racing, may hunt, may require dash-pots or may give too much speed regulation for very much the same reasons as were explained under fly-ball governors. Shaft governors, however, do not permit of as many adjustments as do fly-ball governors. Shaft governors cannot ordinarily be adjusted while in motion. The two principal methods of adjustment, as will be explained, are varying the weights and varying the spring tension (Sec. 255).

NOTE.—THE FORCES REQUIRED FOR SHAFT GOVERNING are ordinarily much greater than those required for governing by the methods explained in Div. 6. In shaft governing, the eccentric must be held by the governor in a certain position for each load—it must be held there with sufficient firmness that the valve-gear friction will not displace it. This necessitates the exertion of a relatively considerable force. Also, the forces which the governor must exert depend on the valve gear and its reaction to the governor and eccentric motion. It is therefore impossible to exactly analyze the forces in a shaft governor by considering only the governor itself. They must be considered in connection with the valve gear which the governor operates. A shaft governor must be specially designed as a part of the engine on which it is to operate.

244. Shaft Governors Employ For Their Operation Forces Of Two Kinds: (1) *Centrifugal force*, Sec. 213. (2) *Inertia*, Sec. 213. In this respect they differ from fly-ball governors

which employ centrifugal force only. How these forces are utilized in shaft-governor operation is explained in the succeeding sections.

245. Centrifugal Force Effects The Permanent Control In Shaft Governors.—Fig. 293 illustrates an imaginary shaft governor which employs only centrifugal force for its operation. In all shaft governors there is a weight (W , Fig. 293) supported by an arm or arranged to slide in guides, G , which are connected

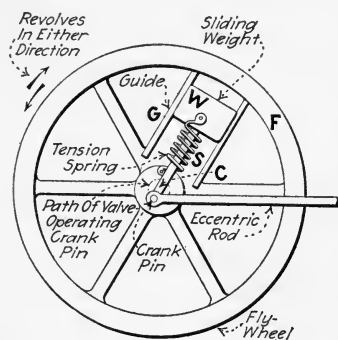

FIG. 293.—Showing imaginary shaft governor which operates by centrifugal force only. (This imaginary construction is never used in actual governors.)

The spring thus counteracts the centrifugal force, holding the governor in such position as to maintain an almost uniform speed.

When W is forced in toward the center it increases the eccentricity of the crank pin (Sec. 148) and when it is forced away from the center it decreases the eccentricity.

NOTE.—By properly proportioning and arranging the weights and the spring, it is possible to make a shaft governor of this centrifugal class so that its parts will move directly proportionally to any change in speed of the engine. But for reasons given in Sec. 248 the force of inertia is also employed in all modern commercial shaft governors.

NOTE.—NO GOVERNOR EMPLOYING CENTRIFUGAL FORCE AS A REGULATING MEANS CAN OPERATE WITHOUT SOME CHANGE IN THE ENGINE SPEED AS THE LOAD ON THE ENGINE CHANGES. In Div. 6, it was stated that no change in governor position occurred until a change in speed had taken place. This statement is equally true of shaft governors in spite of certain manufacturers' claims to the contrary. However,

to a revolving flywheel, F , so that the centrifugal force tends to throw the weight away from the center, C , of the wheel. A spring, S , is employed to counteract the effect of centrifugal force and is so arranged as to restore the weights to normal position when the engine comes to rest. In the governor shown in Fig. 293 the centrifugal force tends to throw W outward and toward the circumference of the revolving wheel, whereas the spring tends to draw W inward.

with shaft governors the difference between the no-load and full-load speeds may be less than one revolution in 300—speed regulation of $\frac{1}{3}$ of 1 per cent. Such a small speed variation would be difficult to detect with a revolution counter. If an engine is operating at no load and the load is suddenly thrown on, the engine may, due to the inertia effect (see Sec. 213) of the governor, attain, in accelerating, a speed greater than the no-load speed before the governor reaches equilibrium. But this extra speed is only temporary. For normal operation, the engine must run a little slower at full load than at no load.

246. Inertia Forces Effect Temporary Control In A Shaft Governor.—

The principle of inertia is employed in shaft governors for preventing sudden changes in speed in somewhat the same way as it is employed in flywheels. The inertia governor may thus be considered a sort of auxiliary flywheel which acts through the valves of the engine instead of acting directly on the crank shaft. The principle of inertia is one of Sir Isaac Newton's laws of motion. It may be stated—as applied to revolving governor parts—thus: A body at rest tends to remain at rest; and when revolving, tends to continue revolving

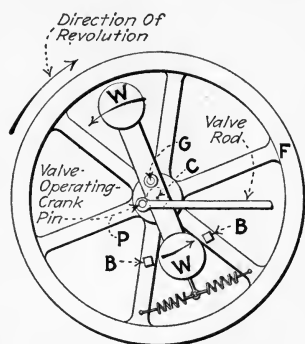

FIG. 294.—Imaginary shaft governor which would be affected by inertia only. (This construction is never used.)

at a uniform speed. Fig. 294 shows an imaginary shaft governor which would operate by inertia only. The weighted bar, *WW*, is pivoted at its center of gravity, *G*. Since the bar is so pivoted, it has no tendency to revolve on its pivot due to centrifugal force. It is held loosely in place by springs and kept from extreme rotation by the stops, *BB*. Now, if the flywheel, *F*, is suddenly started in the direction indicated, the weighted bar will, due to its inertia, tend to "hang back." It will rotate, relative to the flywheel, so that the valve-operating crank pin, *P*, will be brought nearer the center of the shaft, *C*, which is equivalent to decreasing the eccentricity, Sec. 148. This movement will decrease the valve travel and the speed of the engine will thus be checked. A governor of this sort would prevent sudden changes in engine

speed but it would allow any amount of gradual engine-speed change. Consequently, for a shaft governor which is to maintain some definite engine speed, centrifugal force (Sec. 213) must also be employed.

247. A Shaft Governor Secures Prompt Action And Close Regulation By Combining Centrifugal Force And Inertia. The elementary governor bar, IW , of Fig. 295 is so arranged that its mass is affected by both centrifugal force and inertia. The governor bar is pivoted at M (not at its center of gravity)

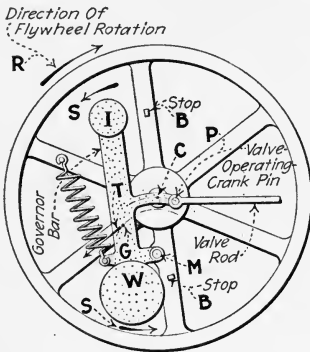

FIG. 295.—Diagram of governor of the "Rites" type. (This arrangement is the most widely used of any shaft governor arrangement but the distances shown above are exaggerated.)

and carries a large "centrifugal" weight, W , and a smaller "inertia" weight, I . The whole bar, however, is acted upon by both centrifugal force and inertia. It is prevented from rotating excessively by the stops, B . The center of gravity of the bar is at G . The bar carries also the valve-operating crank pin, P , which operates the valves of the engine through the valve rod and valve stem. Assume that the flywheel is being started in the direction of arrow R . As the flywheel speed increases, the center of gravity tends to move outward as indicated by the arrow T , but is restrained by the spring. If the speed of the flywheel increases suddenly, the weights, due to their inertia, tend to rotate in the direction indicated at S , against the spring tension. This movement will bring the pin, P , closer to the center, C , and the travel of the valve will thus be reduced. With a reduced valve-travel, the engine will be unable to further increase its speed. After the speed becomes uniform at its higher value, the weights will exert no inertia effect. Inertia will, therefore, no longer keep the governor in its new position but an increased centrifugal force will then have been developed (Sec. 213) due to the increased speed. This force will maintain the governor bar in the new position. If the speed slackens, the above-described processes

will be reversed, the spring operating, after the speed is uniform and inertia is no longer effective, to retain the bar in its low-speed position. The *hunting of a shaft governor* which actually occurs before it attains its final condition of equilibrium for the given load is similar to that described for fly-ball governors in Sec. 229. It is not therefore treated in this explanation.

248. Why Shaft Governors Employ Both Centrifugal Force And Inertia in order to secure prompt action may be explained as follows: A shaft governor, due to the considerable force which it must exert to keep the eccentric in position against the friction of the valve and valve gear, must be relatively heavy—that is, it must be many times heavier for a given service than a fly-ball governor. As explained in Div. 6, a governor which is very heavy is correspondingly slow or sluggish if only centrifugal force is used. Hence, it is obvious that, with heavy weight arms, to insure the prompt action which is essential for close speed regulation, a shaft governor must employ some force other than centrifugal force. Hence nearly all shaft governors are so designed that the inertia of the weights will assist the governor in changing position. By thus employing inertia, a shaft governor obtains more prompt action than is ordinarily possible with a fly-ball governor. The *speed regulation* of a good shaft governor is within less than 1 per cent. regardless of whether the change in load is made slowly or suddenly. Furthermore the governing action is so prompt that a well-designed shaft governor will attain its new position for a changed load within 1 or 2 revolutions, which may represent but a fraction of a second.

249. How A Shaft Governor Controls The Speed Of An Engine may be understood by referring to Figs. 296, 297 and 298. The governor shown is arranged to vary the valve travel without changing the angular advance of the eccentric materially.

EXPLANATION.—The governor is shown in Fig. 296 in full-load position. The valve-operating crank-pin, *P*, which is carried on the governor bar, travels in a large circle, *E*, giving a maximum valve travel. The engine steam port, *A*, has therefore a large opening at quarter stroke and cut-off occurs late. If the load is suddenly thrown off the engine, the

governor will assume the new position shown in Fig. 297, explained in Sec. 247, and the crank pin then travels in a smaller circle, *E'* (Fig. 297). The travel of the crank pin is now but little more than sufficient to

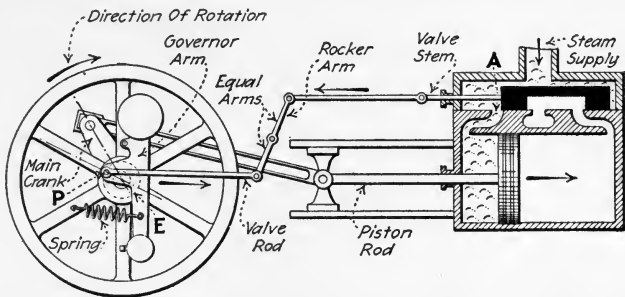

FIG. 296.—Method of governing with shaft governor and slide valve. (Takes steam for nearly full stroke.)

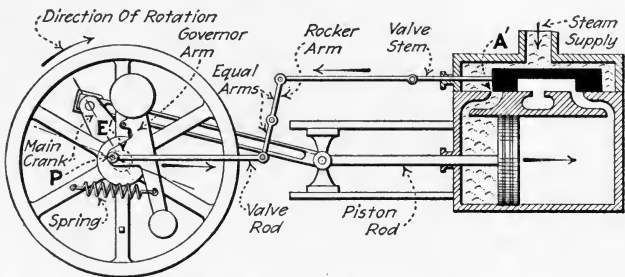

FIG. 297.—Method of governing with shaft governor and slide valve. (Cut-off at about one-fourth stroke.)

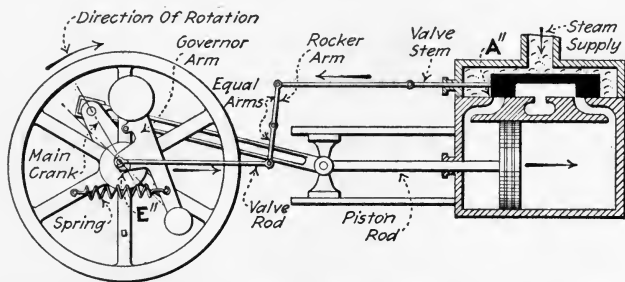

FIG. 298.—Method of governing with shaft governor and slide valve. (Steam cut off entirely.)

uncover the admission port at *A'*, and cut-off occurs a little past quarter stroke. Less steam will now be admitted to the engine and the engine speed will be prevented from further increasing. With the arrangement

shown, compression occurs earlier in Fig. 297 than in Fig. 296. This also helps to cause the engine to develop less power if the governor position is changed as described above. The extreme position of the governor is shown in Fig. 298, where the throw of the eccentric is less than the steam lap of the valve so that the steam is shut off from the cylinder entirely.

NOTE.—The engine shown in Figs. 296 to 298 runs “under.” If the governor arm and spring were reversed in position (turned over from left to right) the engine would run “over.”

250. Reversing An Automatic Engine should be avoided whenever possible. The engine has probably been nicely adjusted before it left the factory and it is usually difficult for the inexperienced person to re-adjust the wheel correctly.

NOTE.—TO REVERSE A TROY AUTOMATIC ENGINE, do not disturb the valve nor remove the flywheel from the engine shaft. Remove the governor arm (Fig. 299) and reverse it on the pin—turn out the side which was against the wheel. Then re-key it to the pin using the other angle key-way which is provided in the pin. The stops, drag spring and coil spring must be carefully reversed in position, restoring the original conditions as nearly as possible. Be sure that the stops do not prevent the governor from shutting off but do prevent it from straining any of the mechanism. Be sure that the friction of the drag spring or other parts has not been made excessive by the change. The wheel must then be re-balanced as explained in the note of the following section.

251. The Balance Of A Shaft Governor And Its Flywheel are important features of design. If the moving parts of a governor have no tendency to rotate about their pivots, due to gravity, when the governor is at rest, the governor itself is said to be in *balance*. If a governor is not in balance, it will, when the engine is running slowly, tend to deflect first one way and then another. A governor flywheel is in balance if its center of gravity lies in the axis about which it revolves. If the flywheel is not balanced it will, when the engine is running, produce a centrifugal force acting at its center of gravity. This centrifugal force will produce undue pressures in the main bearings and excessive bending stresses in the crank shaft. The balance of a governor flywheel may or may not, depending on its construction, be destroyed as the weights assume different positions at various engine speeds. A governor flywheel is in *continual balance* when, as the weights

deflect with centrifugal force, its balance is not destroyed. If a governor flywheel is not in continual balance, it will, theoretically, be out of balance at some governor position. But the flywheel may be balanced for a certain position of its weights by bolting weights, *W* (Fig. 299), at the proper points to the flywheel rim. It is possible for a governor itself to be

I—Enlarged End View Of Shaft

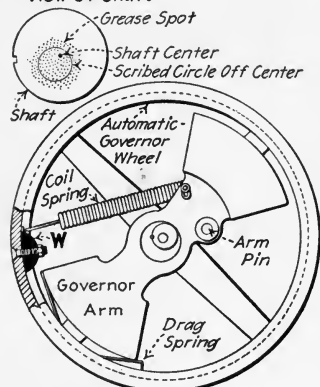

II—Weights For Restoring Balance To Flywheel

FIG. 299.—Illustrating a method of balancing a flywheel. (Governor wheel of a Troy automatic engine.)

in balance without the flywheel being balanced for any or all positions of the weights. Examples of various degrees of governor and flywheel balance are given in the following section.

NOTE.—IF THE FLYWHEEL HAS BECOME UNBALANCED due to reversing the engine or other alterations, the balance may be restored as follows: First find the direction of the unbalanced force. To do this, smear grease or chalk or some other material on the end of the shaft near the center, as shown in I, Fig. 299, so that a scribed line will show on it. Arrange a block, box or chair so as to support or steady a scriber near the shaft center and, while the engine is running, scribe a small circle on the end of the shaft. If the center of the scribed circle is not in the center of the shaft, the flywheel is out of balance. Weight must then be added to the flywheel rim at a point located by drawing a line from the shaft center through the center of the scribed circle and extending this line to the rim. The amount of the balancing weight which is required may be found by first sticking a lump of putty or clay to the rim and making another scribed circle. When the right amount of clay to insure balance is found in this way, select a piece of metal of the same weight as the clay. Bolt the metal to the flywheel rim with a counter-sunk machine bolt.

252. Shaft Governors May Be Classified With Respect To The Arrangement of Weights Employed as follows:

(1) *Balanced governors with two weights and their flywheels in continual balance*, as shown in Figs. 300 and 301. (2) *Balanced Governors with a single weight and their flywheels not in continual balance* (Fig. 302). (3) *Governors with a single arm which carries*

inertia weight, centrifugal weight and eccentric (Fig. 303); the governor and its wheel being nearly balanced in all positions. The action of governors of this type was explained in Sec. 247. (4) *Governors having two arms or an arm and a weight*, the governor and its wheel being nearly balanced in all positions (Figs. 291 and 304). Governors of all of the above classes can be so operated that the regulation is either assisted or retarded by inertia and can be connected to a rotating or a swinging eccentric as desired. In most of the governors here described, the inertia assists the regulation. See Table 254 for manufacturers of engines which employ governors of the various kinds.

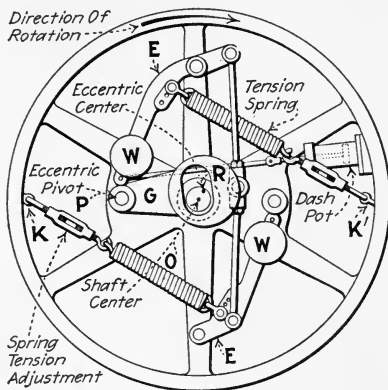

FIG. 300.—Shaft governor which employs two weights. (Governor balanced and fly-wheel in continual balance.)

EXAMPLES.—Figs. 300 and 301 show governors of Class 1 having two weights, *W*, in balance. The eccentric (Fig. 300) is mounted on a plate, *G*, pivoted at *P* and is connected to weight levers, *WE*, by connecting rods in such a manner that the action of centrifugal force, in throwing the weights *WW* outward, causes the center, *R*, of the eccentric to swing toward the center, *O*, of the shaft. The springs pivoted at *K* act against the centrifugal force and hold the weights in a certain position for each speed. The dash-pot simply restrains the motion when too rapid and tends to prevent racing and hunting.

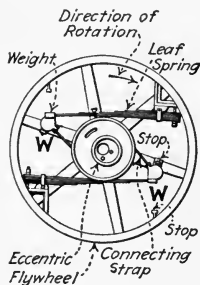

FIG. 301.—“Hardwick” shaft governor as used on the Erie engine.

Fig. 302 is an illustration of a shaft governor the flywheel of which is not in continual balance (Class 2). Although this governor has but a single weight, *B*, its parts are nevertheless balanced. Its advantages over governors of Class 1 are—a lesser number of working parts, simpler construction and less friction. An example of a governor of this class the Robb-Armstrong-Sweet governor (Fig. 309) (see Table 254).

Fig. 303 shows a governor of Class 3 which has a nearly balanced single arm. This governor is of the Rites type, which is extensively used in the United States, and is designed to take full advantage of inertia.

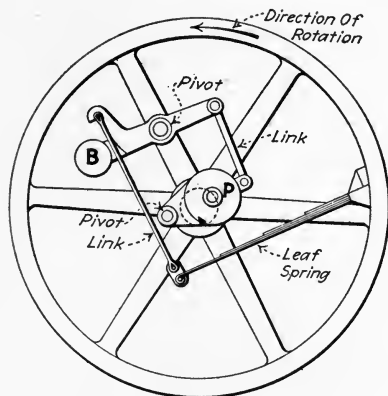

FIG. 302.—Shaft governor employing a single weight, *B*, balanced by the eccentric, *P*. (The flywheel balance depends on the position of *B*.)

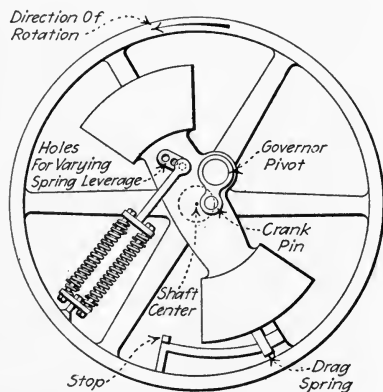

FIG. 303.—Rites governor. (This governor is not in balance nor is its wheel but the flywheel may be balanced with extra weights on the rim; and the governor may, by friction, be prevented from knocking at low speeds so that satisfactory results may nevertheless be obtained.)

Fig. 291 is an example of a governor of Class 4. The advantage claimed for it by the manufacturers is close regulation without the use of a dash-pot to prevent hunting.

NOTE.—Some parts of the following text is based on material from *SHAFT GOVERNORS* by Hubert E. Collins; other parts are based on data from instruction books of the various engine manufacturers.

253. The Two Methods Whereby The Engine Valves May Be Controlled By A Shaft Governor Through The Eccentric Or The Valve-Operating Crank Pin, either of which may be employed in any given governor, are as follows: (1) *The eccentric is rotated or twisted around the shaft.* Thereby the

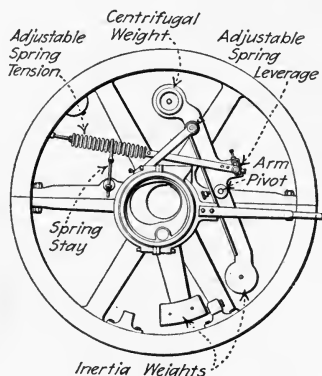

FIG. 304.—Chuse Engine Mfg. Co., governor. (This governor is used on non-releasing Corliss-valve engines to control the position of the eccentric which operates the admission valves only. The exhaust-valve-operating eccentric remains fixed in position.)

angular advance is changed without change of eccentricity or throw. (2) *The eccentric is mounted on a disc or plate which is swung by the governor action across the center of the shaft.* Thereby the throw and angular advance of the eccentric are both changed, the object in the design being to have the lead of the valve change but slightly with different governor positions. With either of the above classes of valve gear, the governor may employ any of the weight arrangements specified in Sec. 252. It follows that the weight arrangement of a governor does not determine its method of valve control.

NOTE.—A SHAFT GOVERNOR OF ANY TYPE MAY USE A CRANK PIN IN PLACE OF AN ECCENTRIC. When the governor is at the end of the shaft, a crank pin is usually used. When the shaft continues on through the

governor, an eccentric, which is properly slotted to permit movement to or from the shaft center is ordinarily employed.

EXPLANATION.—The Buckeye governor of Fig. 316 is an example of Class 1. The eccentric, *C*, has two ears which are connected by links to the ends of the levers, *M*. As the weights, *A*, are thrown out by centrifugal force, the eccentric is rotated in the direction indicated. Its angular advance is thus increased. The Fitchburg governor of Fig. 320 is an example of Class 2; the eccentric, *A*, is so arranged that its throw and angular advance are both varied, see Secs. 148 and 151, giving a practically constant valve lead.

254. Table Showing Classification Of Shaft Governors.

Manufacturer	Governor name	Fig. No.	Class by weight arrangement, Sec. 252	Class by eccentric arrangement, Sec. 253
Ames Iron Works.....	Robb-Armstrong-Sweet	310	2	2
Brownell Co.....	Rites	306	3	2
Buckeye Engine Co.....	Buckeye	316	1	1
Chandler & Taylor.....	Armstrong	311	2	2
Chuse Engine Mfg. Co..	Chuse	304	4	2
Erie Ball Engine Co., Ball engine.	Robb-Armstrong-Sweet	...	2	2
Erie Engine Works, Erie engine.....	Hardwick	301	1	2
Fitchburg.....	Fitchburg	320	1	2
Harrisburg.....	Fleming	314	1	2
Hooven-Owens-Rentch- ler Co., Hamilton en- gine.....	Special*	321	1	1
A. L. Ide & Sons, Ideal engine	{ Rites Armstrong	{ ... 312	{ 3 2	{ 2 2
Liddell Co.....	Rites	306	3	2
Nordberg.....	Special*	...	3	2
Ridgway.....	Rites	308	3	2
Skinner.....	Skinner	291	4	2
Troy.....	Rites	307	3	2

* These two governors are not shaft governors according to the definition in Sec. 242, but are in a class by themselves. They are very similar to shaft governors, however, and because of their importance are here included.

255. Some Effects Of Weight Or Spring Adjustment On Shaft-Governor Operation may be stated as follows: *The sensitiveness of shaft governors and the speed at which they will regulate depend principally on the following conditions: (1) Tension of springs. (2) The distance from the point where the springs are attached to the weight or lever pivot. (3) The sensitiveness of the springs—that is, the distance they will deflect for a given increase in force. (4) The angle at which the spring acts to the direction which the governor arm or weight tends to move. (5) The mass of the weight which produces centrifugal force. (6) The distance of the center of gravity of the weight from the fulcrum. (7) The angle between the direction in which the weight tends to move and that in which it is free to move.* Substituting a heavier spring, increasing the spring leverage, or shifting the spring more in line with the direction in which the movable end of the spring moves, makes the governor less sensitive. Increasing the centrifugal weight and at the same time adjusting the spring so as to give the same speed makes the governor more sensitive—in fact, the governor may thus be made unstable. Small changes in speed may be made by changing the centrifugal weight or spring tension (whichever is recommended by the manufacturer) without any other apparent effects.

256. Table Showing Principal Adjustments Of All Shaft Governors.

Part	Spring		Weight	Weight and spring	
	Substitute heavier spring or increase spring leverage	Increase tension of same spring		Increase centrifugal weight or weight leverage	Increase weight and substitute heavier spring
Change.....	Faster	Faster	Slower	May be the same	May be the same
Effect on engine speed.....	May be the same	More sensitive	More sensitive	More powerful	More sensitive, less stable
Change.....	Substitute lighter spring or decrease spring leverage	Decrease tension of same spring	Decrease centrifugal weight or weight leverage	Decrease weight and substitute lighter spring	Decrease weight and tension on same spring
Effect on engine speed.....	Slower	Slower	Faster	May be the same	May be the same
Effect on governor.....	May be the same	Less sensitive	Less sensitive	Less powerful	Less sensitive, more stable

NOTE.—THE COMMON METHODS OF CHANGING ENGINE SPEED with shaft governors are to vary the spring tension or spring leverage or to vary the centrifugal weight or its leverage. Slight speed changes by these methods produce no other apparent effects, but larger speed changes produce the effects noted above. In the table it is assumed that, when one factor is varied as noted, all the other factors are kept the same. These adjustments apply to all shaft governors, independent of type.

257. Some Troubles Which May Be Encountered In Operating Any Shaft Governor and their remedies are as follows: (1) *The governor is sluggish.* Sluggishness in shaft governors usually results from one of two causes. Either there is too much friction or the governor is too nearly neutral (isochronous) to be stable. The friction may be in the dash-pot or anywhere in the mechanism as explained in the following section. If the dash-pot resists the movement of the governor too much, a larger hole in the piston or larger valve opening or a lighter oil will remedy the trouble. If the governor has been adjusted for very close regulation, it may lack the power to change its position promptly. The remedy (Table 256) is to increase the weight and use a stronger spring so that the original speed is obtained or to increase the spring leverage where means of so doing is provided. Governors of the Robb-Armstrong-Sweet type (Sec. 263) may be sluggish when adjusted for too much regulation.

(2) *The governor hunts.* This may be due to very close regulation with a free-moving governor. It may usually, under these conditions, be corrected by introducing more friction by means of a drag spring or preferably a dash-pot. If good action cannot be secured in this way, the governor should be adjusted for larger regulation as explained above.

(3) *The engine speeds up or races.* The spring may be entirely too tight or too stiff for the desired speed. The weights may be much too light or, in the Rites type (Sec. 260), too nearly balanced about the weight pivot. Under these conditions, adjust the weight and spring for the desired speed.

NOTE.—RACING IS MOST FREQUENTLY CAUSED BY FRICTION of parts or other local troubles. There is, however, a noticeable difference between racing caused by over-sensitiveness or too weak springs and that caused by friction. When it is caused by spring tension alone, the changes in speed will be rapid, even, and within a certain range. When caused by friction, the weights will stick in their inner position until the speed developed is so high as to throw them out; or, when the engine is above speed, they will stick where they are until the speed is reduced enough for the springs to draw them back again. Such changes are usually accompanied by noise when the change takes place.

258. Most Troubles With Shaft Governors Are Due To Some Part Of The Mechanism Sticking or not moving freely. All of the well-known makes of modern shaft governors, regardless of their class, are thoroughly adjusted, tested, regulated, and set by their makers usually before they are shipped from the factory. Hence, when they are delivered to the operating engineer, they should regulate within the guaranteed speed range. The difficulties which arise after the governors have been in service for an extended period usually are due to wear or to an accidental cause, and usually can be remedied readily. After a governor has been perfected and has run satisfactorily, there is no reason why it cannot be restored to its original condition. Often the trouble is a slight one, so small as to be overlooked.

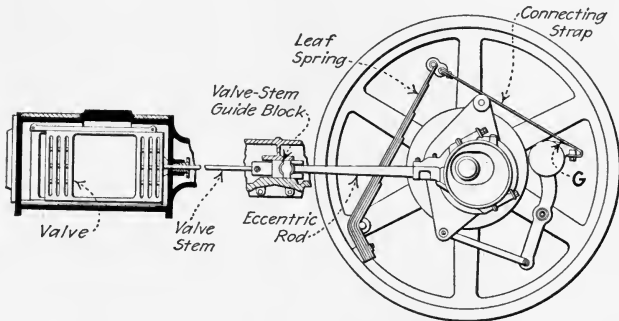

FIG. 305.—Sweet governor, operating gridiron valve.

EXAMPLES.—An engineer may, with a spanner wrench, give the valve-rod gland a half turn to tighten it up; this may cause the engine to run away. An engine having a Sweet governor (Fig. 305) may race if a single very small grain of gravel, *G*, gets between the band which connects the spring and the weight arm and the weight arm itself. Again, a cap which pinches on one of the fulcrum-pins or a slight burr on a valve-rod has caused trouble in a governor. The slightest thing should not be overlooked. Dry pins often cause trouble. Hence a governor should be oiled as regularly as any other part of the engine. About once a month, when the engine is operating continually in a dirty atmosphere, all pins and bearings should be taken apart and cleaned.

When a search for trouble begins, nothing should be neglected from the governor eccentric to the farthest edge of the valve in the valve

chest. Disconnect the eccentric rods from the governor eccentric and remove or release the spring or springs from the weight arm or arms. Then move the weight arms in and out from inner to outer positions. Most of the shaft governors on engines from 5 h.p. to 1,000 h.p. are so counterbalanced that, when thus dismantled, one man should with the smaller engines be able to easily move the parts in and out with one hand. On the larger engines, he should be able to do this with both hands but he should never use a bar of any kind.

If the weight arms do not move with sufficient freedom to permit this, the trouble is probably caused by dry or cut pins, pinching caps, bent rods or links which make the pins bind, pinching or dry eccentric straps, or the eccentric binding (in some instances between a bearing and governor-wheel hub). Or sometimes gummed oil and grit cause it.

If the governor is free and in perfect condition, disconnect the valves from the rockers or valve-rod slides, as the case may be. Then look for dry surface of pins or bearings or slides, bent rods and other like conditions. This done, see that the valve stems are straight and true, and in line with their connections; also that their bearings do not bind and are not dry. See whether they are burred or are worn so small in the stuffing box that the packing when pulled tight binds the stems. Note whether the packing is old and dry.

Look into the steam chest. See if the valve is set properly and if it leaks or if the pressure-plate binds. Often an engineer forgets that proper valve setting (see Div. 4) is as essential as it is to have the governor free and well lubricated.

NOTE.—GREASES AND LUBRICANTS WHICH DRY OUT AND LEAVE DEPOSITS SHOULD BE CAREFULLY AVOIDED FOR SHAFT GOVERNORS. A thin grease, the consistency of vaseline, is preferable for the roller bearings and pins. Cylinder oil is satisfactory for the smaller pivots. The roller bearings should preferably be examined, cleaned and oiled monthly.

259. In Adjusting Shaft Governors, the engineer should first make sure that the main pin or pins and their bushings are free and properly lubricated, and that the valve is properly set and runs freely. If the arm is heavy enough to drive the valve, see whether the desired governing effect can be produced by adjusting the spring. Avoid adding unnecessary weights and the consequent overstraining of springs, bushings and pins.

NOTE.—IT MAY BE NECESSARY TO ADJUST THE SHAFT GOVERNOR WITH NO OTHER DATA THAN THAT WHICH BECOMES AVAILABLE FROM WATCHING THE ELECTRICAL SWITCHBOARD METERS, while the engine is running in service. The proper remedy for the apparent fault may be

applied on the occasion of the next shut-down. It may take an hour's careful watching of the switchboard instruments to determine the real action of the governor. The only certain procedure is to wait for the load to so change that the symptom for which one is watching will be shown. That is, the load should remain constant long enough to give the engine time to attain a constant speed. The observations should be repeated until the exact constant speeds under several different loads are ascertained.

NOTE.—A COMMON CAUSE OF COMPLAINT WITH SHAFT GOVERNORS IS HAMMERING of the weighted arm on the stops in starting or shutting down the engine. This can often be overcome on a Rites type governor by moving the attached weights and noting whether hammering is increased or diminished. Usually the proper change is to add weight on the spring side of the arm and to increase the spring tension, though it may be necessary to add weight at both ends. It is a peculiar fact that friction in the valve gear operates to help the governor spring so that an engine may be speeded up several revolutions by excessively tight valve-stem packing or any similarly acting cause. It is well to look over the valve motion as a possible cause of any unaccountable change of speed. If a *brake or drag spring* is used on the governor the friction may be increased to prevent hammering; but if it is set up too tightly, it may cause continual changes of speed through its action in checking the governor arm as it swings out or in, and so prevent the arm from floating gradually to the proper position.

260. The Rites Governor Is Used By A Number Of Different Engine Manufacturers: see Table 254. The action of this governor was explained in Sec. 247. In practice, as the load increases, this governor usually changes not only the throw of the eccentric but also its angular advance. Thus, the points of compression and cut-off are advanced but the lead remains practically constant. The movement of the governor is much exaggerated in Figs. 295 to 298. The actual layout is shown in Fig. 306. The Rites governor as used on the Troy vertical engine is shown in Fig. 307, and on the Ridgway engine in Fig. 308.

261. Rites Governors Are Sometimes Provided With Dash-Pots Or Drag Springs For Limiting The Rate Of Movement. The dash-pot, *G* (Fig. 308), is filled with oil for side-crank engines and with air for center-crank engines. A plug having an opening of proper size is inserted in the bottom of the air-filled pot to regulate the rate of movement. A by-pass and valve are provided for regulating some oil dash-pots.

Others are controlled by holes in the pistons (Sec. 230). Air dash-pots are more likely to give trouble from sticking with

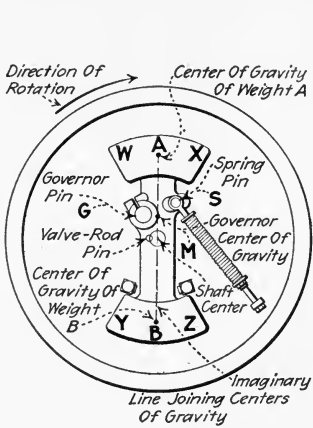

FIG. 306.—Lay-out of Rites governor. (The locations of the centers of gravity in A and B may be shifted by adding movable weights to or removing movable weights from them, or by shifting the position of the movable weights.)

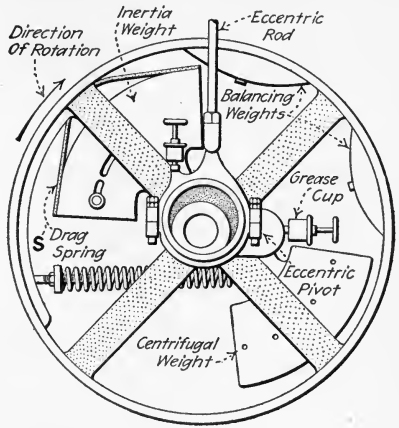

FIG. 307.—Governor of the Troy vertical engine. (Rites type.)

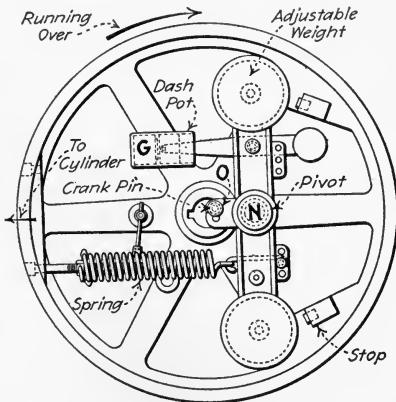

FIG. 308.—Governor of the ridgway automatic engine. (Rites type.)

dirt than are oil dash-pots and should therefore be closely watched and lubricated with cylinder oil. Dash-pots may be adjusted for greater or less promptness as explained in Sec.

233, Div. 6. The drag spring, *S* (Fig. 307), introduces mechanical friction to prevent too much movement of the governor. There is ordinarily sufficient vibration of the engine to prevent such springs from making the governor bind when in the wrong position.

262. Some Special Adjustments Of The Rites Governor (Fig. 306) are as follows: (1) Shifting the movable weights, which are frequently provided, from *W* to *X* or from *Y* to *Z* increases the weight leverage; see Table 256. (2) Shifting movable weights from *B* to *A* increases the centrifugal weight. Removing weights from positions *B*, *W* or *Y* has an effect similar to that of adding them at *Z*, *A* or *X*. Shifting the spring pivot, *S*, farther from the governor pivot, *G*, decreases the sensitiveness.

263. The Robb-Armstrong-Sweet Governor, which is used by many manufacturers (see Table 254), is shown in

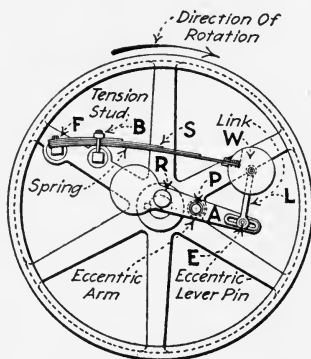

FIG. 309.—Simple Robb-Armstrong-Sweet governor.

Figs. 309 to 313. This governor is placed in the second class in Secs. 252 and 253. The weight, *W*, is fastened directly to the spring, *S*, which is secured to the flywheel rim, *F*, or spoke. The tension on the spring is changed by taking up or slackening the tension-studs, *B*. The eccentric arm, *A*, is pivoted at *P*, moving the eccentric or eccentric pin, *R*, which changes the travel of the valve and the point of cut-off. The arm, *A*, is actuated by the spring by means of one link, *L*, one end of which can be changed in its position by shifting the pin into any one of the series of holes shown.

NOTE.—IN ADJUSTING ROBB-ARMSTRONG-SWEET GOVERNORS: *To increase the speed, give more tension on the spring. To decrease the speed, give less tension on the spring. To get closer regulation and sensitiveness, move the pin, E, in the eccentric lever closer to the shaft center. To*

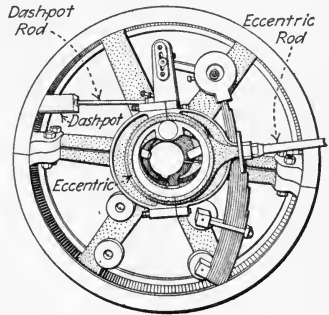
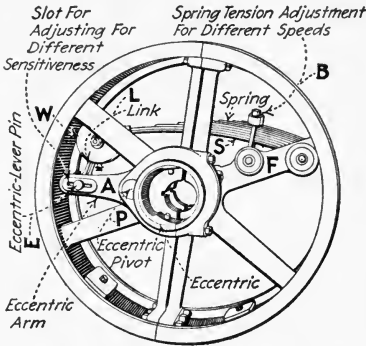

FIG. 310.—Governor of the Ames engines. (Robb-Armstrong-Sweet type.)

FIG. 311.—Governor of Chandler & Taylor engine. (Armstrong type.)

make more stable and sluggish, and prevent racing, move the pin, E, closer to the rim of the wheel. No change of weight is provided for, as the above-suggested adjustments are considered by the makers to be sufficient to cover all requirements.

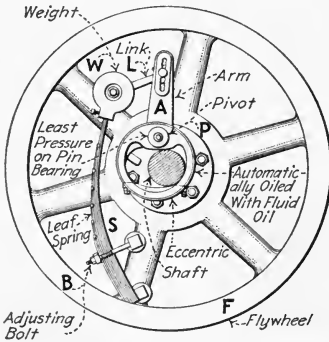

FIG. 312.—Side view of shaft governor of the "Ideal" Corliss-valve engine.

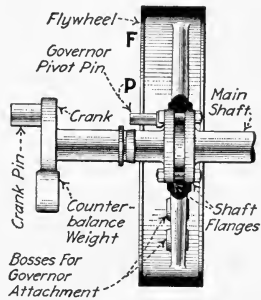

FIG. 313.—Sectional elevation of "Ideal" Corliss-valve engine shaft with governor mechanism removed.

264. The Principal Adjustments Of The Fleming-Harrisburg Engine Governor (Fig. 314) in their recommended order are: (1) For greater or less speed, increase or decrease the weights, W, in the centrifugal (larger) weight pockets, keeping

them equal in the two larger weight pockets. (2) If more speed adjustment is required, vary the spring tension. (3) For more sensitiveness, shift the traversing blocks, *B*, in the

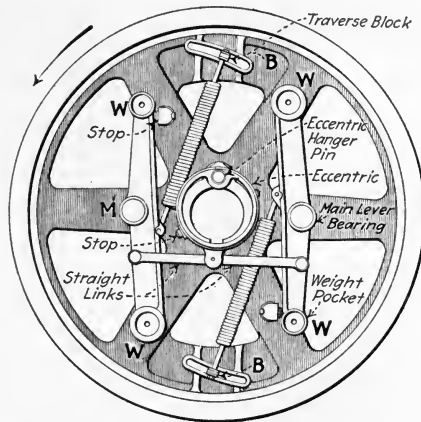

FIG. 314.—Fleming-Harrisburg centrally balanced centrifugal inertia governor. This shows a right-hand governor, engine running over.

slots farther from the centrifugal weights. For less sensitiveness—more stability—shift the blocks closer to the centrifugal weights.

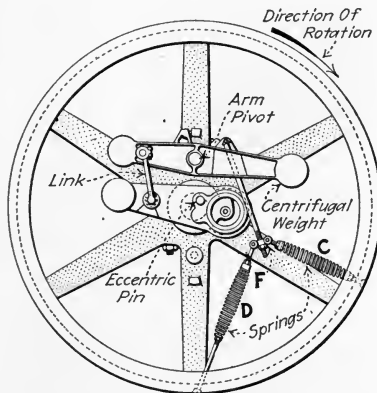

FIG. 315.—American-Ball engine governor.

265. The American-Ball Engine Governor (Fig. 315) is of class 4, Sec. 252. The advantage of the two springs, *D* and *C*, is that there is little bowing outward of the springs with cen-

trifugal force with this spring arrangement. If spring *C* is slackened, and spring *D* tightened, the governor will be more sensitive. If both are tightened at once by nut *F*, the speed will be increased.

266. The Buckeye Governor (Fig. 316)) has several unique features. It controls only the cut-off eccentric. The Buckeye engine is fitted with a fixed eccentric which controls the other

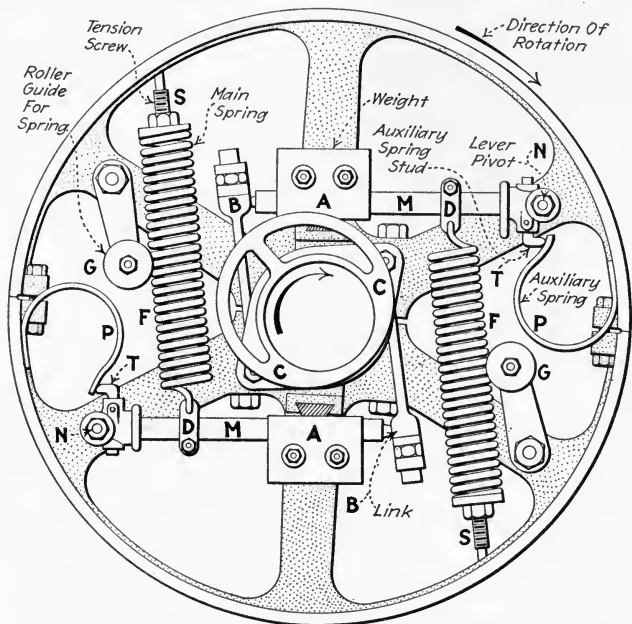

FIG. 316.—Buckeye engine governor. (Employs two weights in gravity balance changes only angle of advance.)

steam events—namely, release, compression and admission. The governor changes only the point of cut-off. This governor changes only the angular advance of the eccentric. The travel of the valve therefore remains constant. An advantage claimed for this method of governing is that the valve which has a constant travel wears the valve seat evenly. If the valve travel is less under light than under heavy loads, shoulders may be worn on the seat at the ends of the valve travel when the engine is running under light load. The valve will then strike these shoulders when an extra load is put on the engine.

EXPLANATION.—The weights, *A* (Fig. 316), are mounted on weight arms, *M*, which are pivoted at *N*. The links, *B*, connect the weight-arm ends to the ears of the eccentric, *C*. When the weights, *A*, are moved outward by centrifugal force against the tension of springs, *F*, the eccentric may be turned a maximum of 90 deg. around the shaft as a center. Springs, *F*, are fastened to arms, *M*, by means of spring clips, *D*, which may be adjusted on the arms to increase the leverage of the spring and thereby increase its effective strength. The outer ends of the springs are connected to the rim of the flywheel by tension screws, *S*, by which the tension of the springs may be varied. The auxiliary leaf springs, *P*, act against the spring studs, *T*, and have the effect of increasing the spring tension near the minimum-speed position. The rollers, *G*, prevent the springs from bowing outward due to centrifugal force, at speeds of 250 r.p.m. or more.

NOTE.—SOME SPECIAL TROUBLES OF THE BUCKEYE GOVERNOR AND THEIR REMEDIES are; see Fig. 316. *Auxiliary springs, P, too weak.* The performance when these springs are too weak will be the same in kind

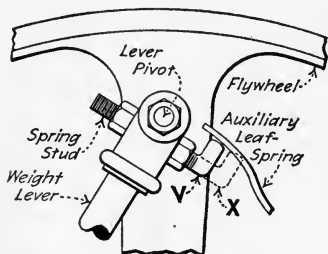

FIG. 317.—Adjustable spring stud for auxiliary springs of Buckeye governor.

as though they were absent entirely, though more moderate in degree. On starting, the engine will run above its proper speed before the levers, *M*, will expand. Then they will fly out violently. Stable regulation will be possible only with loads so light as to regulate at one-fourth stroke cut-off or earlier. That is, stable regulation can be obtained only with loads such as require the levers to act solely in the outer half of their range of movement. At heavier loads, the governor will race continually. The effective strength of the auxiliaries may be increased by lengthening the spring stud as from *V* to *X* (Fig. 317).

Auxiliary springs, P, too strong. On starting up, the levers will move out at noticeably less than rated speed and expand gradually as the speed increases till the limit of the follow of the auxiliary springs is reached. Then, if they are much too strong, the expanding movement will temporarily cease until normal speed is reached, when they will finish their expansion with proper promptness. The regulation will be the same as in the previous case when the load was too light to bring the auxiliary springs into action. But, with heavier loads, the speed will be slow in proportion to the undue strength of the springs. At maximum load, that is, just sufficient load to bring the levers to their inner stops, the speed will be reduced to about what was required to start them out. In all of the foregoing cases, the tension of the main springs was assumed to be what it should be with the auxiliaries at their best adjustment. That tension of the main springs which may be carried, without racing at any load, is always less than will be required when auxiliary springs are applied.

267. The McIntosh & Seymour Engine Governor (Figs. 318 and 319) is itself balanced and its flywheel is in continual balance. Like the Buckeye governor, it controls a cut-off

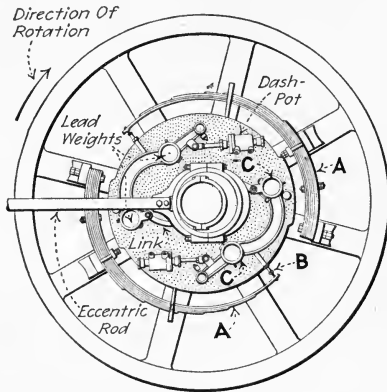

FIG. 318.—McIntosh & Seymour engine governor fully deflected. (No-load position.)

eccentric only by varying its angle of advance. The weights, *C*, are deflected outward by centrifugal force against the tension of the leaf springs, *A*. The governor may be adjusted

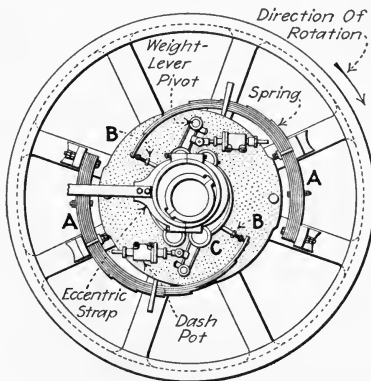

FIG. 319.—McIntosh & Seymour engine governor at rest.

for greater spring tension at *B* and for greater centrifugal weight by adding lead weights to the pockets, *C*. The manufacture of this engine and governor has been discontinued.

268. The Fitchburg Governor (Fig. 320) employs two weights, *HH*, which are balanced with the other governor parts, and moves the eccentric in a straight line, thereby varying its throw. For the larger engines, the governor is mounted within a wheel-like casting, called a *governor case*, which is clamped to the engine shaft.

NOTE.—IN SETTING THE FITCHBURG GOVERNOR, the location of the governor case, *K* (or flywheel when the governor is mounted within a flywheel), is determined by placing the engine on one dead center and rolling the case around the shaft until the offset, *O*, of the eccentric

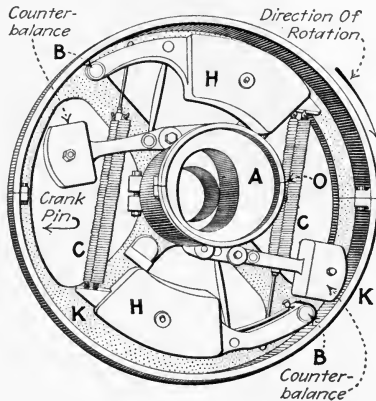

FIG. 320.—Fitchburg governor. (The legend "Crank Pin" means that the crank pin is located in the position indicated by the arrow. The crank pin is not shown.)

is on the opposite side of the shaft from the crank-pin. Then roll *K* carefully into such a position that when (with the springs removed) the eccentric, *A*, is thrown back and forth across the shaft, no end motion is given to the valve rod. At this place tighten the governor case firmly upon the shaft. Turn the engine to the opposite dead center, and again move the eccentric back and forth across the shaft. If there is at this end any end motion to the valve rod, change the position of the governor case on the shaft enough to make the motion just half as much, then fasten the governor case firmly in this final position by drilling into the shaft for the point of the set screw and then tightening the clamp-bolts to place solidly. Put in the springs, *C*, and tighten them until the engine operates at the proper speed. Be sure to tighten up the springs that go through the counterbalance which hangs nearest the pin *B* (when the governor is at rest) about three-fourths of an inch more than the springs on the other side.

NOTE.—WHEN IT IS DESIRED TO CHANGE THE DIRECTION OF ROTATION OF A FITCHBURG ENGINE, a new eccentric must be procured from the makers and put on in place of the one on the governor. The ends of the links which connect the weight arms must be changed on the counter-balance weight-arm end, to the holes opposite to those which they occupied when the old eccentric was used.

269. The Governing Mechanism Of The Hamilton Uniflow Engine is shown in Figs. 321 to 323. Centrifugal force is developed in two flat curved weights, *W* (Fig. 322), which are

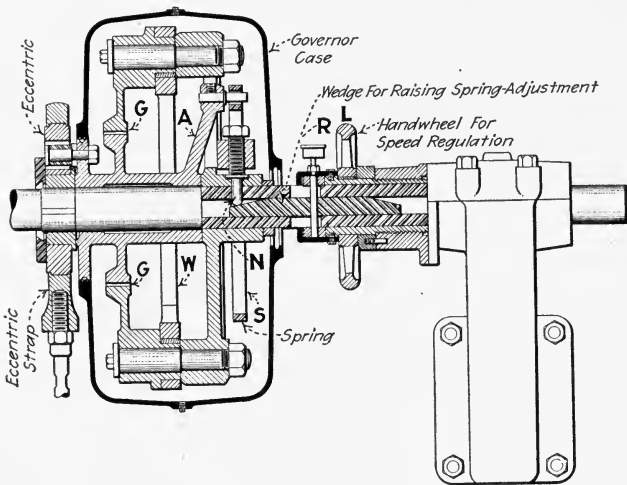

FIG. 321.—Longitudinal section of governor of the Hamilton uniflow poppet-valve engine.

pivoted at *P*. These deflect outward, rotating the eccentric mounting, *E*, through the geared sectors, *G*. The rotation of the eccentric is opposed by the spring *S*, through the arm, *A* (Fig. 323). The tension on the spring, *S*, may be adjusted when the governor is at rest by the screw, *N*. This tension may also be adjusted when the engine is running by means of the handwheel, *L* (Fig. 321). This wheel is mounted on a screw-threaded sleeve which forces the wedge, *R*, against the screw, *N*, when *L* is turned. The movement of *N* is communicated to spring *S*, through the spring-mounting lever, *M*.

By thus changing the spring tension, the speed at which the governor controls the engine may be changed.

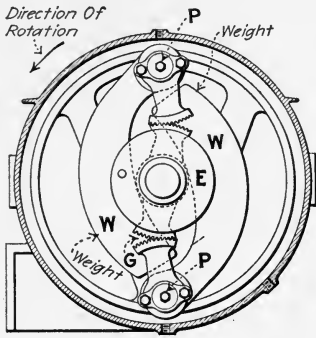

FIG. 322.—Hamilton uniflow-engine governor showing weights and eccentric-rotating sectors.

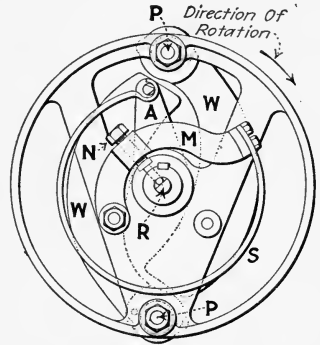

FIG. 323.—Hamilton uniflow-engine governor showing screw for spring-tension speed adjustment.

270. Setting The Valves Of An Automatic Engine consists mainly in adjusting the length of the valve stem. Shaft governors are nearly always keyed to the shaft and so the position of the governor is fixed and determines the position

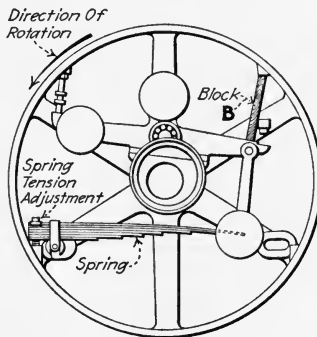

FIG. 324.—Showing governor blocked in extreme short-travel position.

of the eccentric. If it is desired to change a shaft governor for greater or less equal lead (see Sec. 174) a new keyway must be cut. The valve travel of an automatic engine usually varies with the load and is determined by adjustment of the governor. Directions for valve setting are given in Div. 4.

Fig. 324 illustrates the method of blocking a flywheel governor when the valves are being set.

QUESTIONS ON DIVISION 7

1. What is a shaft governor? An automatic engine?
2. How does the governing action of a shaft governor and slide valve differ in economy from that of a throttling governor? From that of a fly-ball-governed Corliss releasing gear?
3. Why must a shaft governor exert more force for a given service than must a fly-ball governor?
4. Explain by a sketch the action of a shaft governor which is affected by centrifugal force alone. Why must some speed change occur in order that a centrifugal governor may operate?
5. What is the principle of inertia? How is it employed in shaft governors? Why cannot inertia be used in a shaft governor as the only governing force?
6. Explain how inertia and centrifugal force come into play in inertia governors. Why is it more necessary to employ inertia in shaft governors than in fly-ball governors?
7. What difficulties are encountered in reversing shaft-governed engines? Why must the flywheel usually be rebalanced after a governor has been reversed?
8. When is a shaft governor said to be balanced? Its flywheel? When in continual balance?
9. Explain how the balance of a flywheel may be restored.
10. Name four classes of governor weight arrangement and name a manufacturer of governors of each class.
11. What are the two methods of valve control through the eccentric? Name a governor which uses each method.
12. Which of the above methods of valve control is largely used with simple slide-valve automatic engines?
13. What are the principal methods of changing the speed of a shaft-governed engine?
14. How may the sensitiveness of a governor be decreased when there is no means of changing the spring leverage?
15. What is one cause of excessive hunting of a shaft governor? Of sluggishness? Of racing? Give one remedy for each.
16. What is the most common source of trouble with shaft governors? How may this trouble be located in the various parts of the governor mechanism?
17. What lubricant is satisfactory for governor roller bearings? For smaller governor pivots?
18. How may data be obtained, in steam-engine-driven electric-power generating stations, for governor adjustment?
19. What causes a governor to hammer against the stops when starting or stopping? How may this trouble be sometimes corrected in a Rites governor?
20. Explain by a sketch the effects of shifting weights from one part of a Rites governor to another.
21. Name two adjustments of the Robb-Armstrong-Sewet governor.
22. Name three adjustments of the Fleming governor.
23. What is the advantage of the spring arrangement of the American-Ball engine governor? How may this arrangement be used to vary the sensitiveness of the governor?
24. Explain the action of the auxiliary springs of the Buckeye governor. What is the bad effect if they are too weak? What if they are too strong? How may their effective strength be increased?
25. What is the *governor case* of a Fitchburg engine? Explain how to set the governor case on the shaft.
26. Explain a simple method of setting the slide valve of an automatic engine.

DIVISION 8

COMPOUND AND MULTI-EXPANSION ENGINES

271. Compound And Multi-Expansion Engines (Fig. 325) are widely used where the nature of the load requires the use of reciprocating engines and where better economies are desired than can be obtained with simple engines. Compound engines range in capacity mainly from 50 to 4,000 h.p. For marine service and for driving machinery in mills, compound and multi-expansion engines find extensive application. For electric power generation, the turbine is gradually replacing the compound engine because of the turbine's lower first cost and more compact form; and, under many conditions (Sec. 299), its better economies. Also the use of the turbine for marine service is increasing. Where fuel is very cheap, as in a saw-mill, or where there is use for the exhaust steam for heating or industrial purposes, a simple engine is usually preferred to a compound one because of its lower first cost; the economy of the engine then being a secondary consideration.

NOTE.—FOR DEFINITION OF THE COMPOUND ENGINE and classification with respect to cylinder arrangement, see Secs. 34 to 40.

272. The Compound Engine Usually Operates Through Large Temperature And Pressure Ranges.—*The temperature or pressure range of an engine* is understood to mean the difference between the highest and lowest temperatures or pressures of the steam within the engine cylinders. Compound engines are commonly operated condensing at 150 to 200 lb. per sq. in. boiler pressure and sometimes, if the valves are properly designed, on superheated steam. Nothing is gained by using a compound engine for service where the temperature and pressure range is small. That is, for a boiler pressure of 100 lb. per sq. in. and a back pressure of 5 lb. per sq. in. gage, the economies of the simple and compound engines would be so

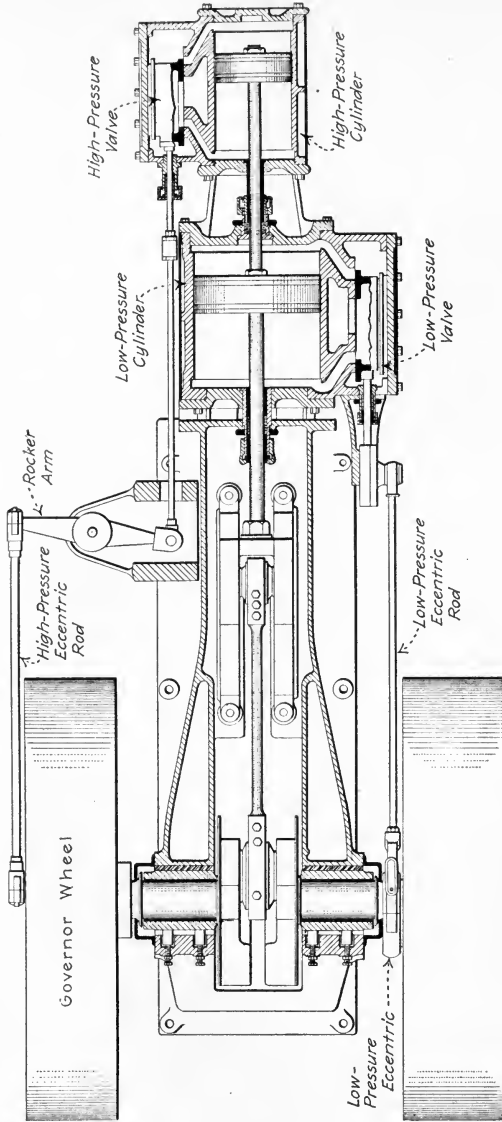

FIG. 325.—Section of Skinner tandem-compound engine showing governing of high-pressure cylinder by shaft governor.

nearly equal that the additional first cost of the compound engine would, probably, not be justified. "In general" (Gebhardt), "compounding increases the steam economy at rated load 10 to 25 per cent. for non-condensing and from 15 to 40 per cent. for condensing operation." At fractional loads the saving in steam due to compounding is smaller; in fact, a compound engine may, at light load, use more steam than a simple engine would use at the same load.

NOTE.—THE SAVING SHOWN BY THE COMPOUND ENGINE OVER THE SIMPLE ENGINE IS GREATER AT HIGHER BOILER PRESSURES. A certain triple expansion condensing engine is credited with a consumption of but 11.23 lb. of saturated steam per i.h.p. hr. at 257 lb. per sq. in. pressure; whereas the consumption of simple non-condensing, single-valve engines is usually about 30 to 35 lb. of steam per i.h.p. hr.

273. The Principal Advantages Of The Compound Or Multi-Expansion Engine Over The Simple Engine having the same total ratio of expansion (see note below) and power output may be enumerated as follows; each is discussed in a succeeding section: (1) *Reduced cylinder condensation* because of the lesser temperature range in each cylinder (Sec. 274). (2) *Reduced leakage loss* partly due to the lesser pressure difference in the two ends of each cylinder. That is, the "net pressure" on each piston is reduced by compounding (Sec. 275). (3) *Higher mechanical efficiency* because the ratio of the maximum to the mean effective pressure in each of the cylinders is greatly reduced. This ratio is usually from 40 to 70 per cent. of what it would be were the same total ratio of expansion employed in a simple engine (Sec. 276). (4) *More even torque* when cross compound engines are used with their cranks set at 90 deg. or 120 deg. apart (Sec. 277). *The important disadvantages of the compound or multi-expansion engine* are its greater first cost, its greater complexity and the large amount of room which it requires.

NOTE.—THE RATIO OF EXPANSION is the final volume of the steam at release divided by its original volume at cut-off. In a compound engine, the final volume at release is in the low-pressure cylinder and the original volume at cut-off is in the high-pressure cylinder.

NOTE.—TORQUE is the stress on a body which tends to cause it or causes it to turn. Torque is conveniently measured in *pound inches*.

A pound inch of torque is exerted by a force of one pound acting at a radius of one inch. The torque exerted in Fig. 326 by the connecting rod on the crank shaft is $500 \times 14 = 7,000 \text{ lb. in.}$

EXAMPLE.—Assume that a compound engine has a high-pressure cylinder clearance of 6 per cent. and a displacement volume of 2.9 cu. ft., and cuts off at 0.32 of its stroke. The low-pressure cylinder has a displacement and clearance volume of 11.8 cu. ft. total. What is the ratio of expansion? The boiler pressure is 176 lb. per sq. in. abs. Assuming that release occurs at the end of the stroke what is the pressure at release in the low-pressure cylinder? Assume that the expansion is hyperbolic—that is, the absolute pressure varies inversely as the volume.

SOLUTION.—The volume of the steam at cut-off is 0.32 of the displacement volume plus the clearance. That is, $(0.32 \times 2.9) + (0.06 \times 2.9) = 1.103 \text{ cu. ft.}$ Then the *ratio of expansion* = $11.8 \div 1.102 = 10.7$. If the absolute pressure varies inversely as the volume, the final pressure at 10.7 times the original volume is $176 \div 10.7 = 16.4 \text{ lb. per sq. in. abs.}$ The final pressure at release is always somewhat different in practice than the value thus calculated.

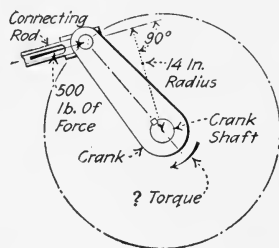

FIG. 326.—Illustrating torque or turning moment exerted in an engine crank.

274. How The Compound Engine Avoids Excessive Cylinder Condensation When Employing Large Temperature And Pressure Ranges may be understood by reference to Figs. 327, 328 and 329. The phenomena of cylinder condensation is described below. As explained in the author's PRACTICAL HEAT under "Gas And Vapor Cycles," the larger the steam temperature and pressure range through which the engine operates, the greater will be its possible thermal efficiency provided the steam is used economically. But, if a simple single-valve engine were used with a large temperature range, there would be so much cylinder condensation that the high possible efficiency would not be even approximately realized. If an engine cylinder is properly lagged (insulated), there is little cylinder condensation due to radiation—it is nearly all due to the behavior of the steam during the stroke as explained below.

EXPLANATION.—In the single-valve engine (Fig. 327) the steam ports, *H*, are alternately filled with live steam and exhaust steam. (The

following temperatures are taken from a steam table.) The exhaust steam at 120 deg. fahr.—26.5 in. of mercury vacuum—must pass out

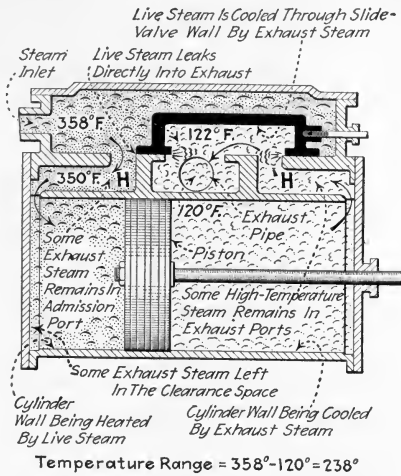

FIG. 327.—Showing live steam and exhaust steam in contact with parts of a single-valve engine. (The engine is assumed to operate condensing at 150 lb. per sq. in. and 26.5 in. of mercury vacuum.)

through the same ports through which the live steam enters at 358 deg. fahr.—135 lb. per sq. in. gage pressure. It is evident that the walls of

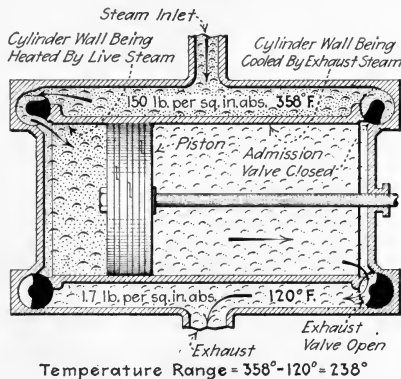

FIG. 328.—Showing live steam and exhaust steam in contact with cylinder walls in a simple four-valve engine.

the ports as well as those of the cylinder are alternately heated and cooled. They are heated by the live steam which then condenses on them, and cooled by the re-evaporation of this condensed steam when the pressure

is lowered. Some of the steam, by thus condensing and re-evaporating—passes through the cylinder without doing work. In the simple four-valve engine (Fig. 328), the steam alternately heats and cools the cylinder walls but the valves and ports remain at a fairly constant temperature. Thus the four-valve engine avoids some of the cylinder condensation which takes place in the single-valve engine because the steam passages and the valves themselves are not heated and cooled. Furthermore, the exhaust steam in the clearance space of the simple engines of Figs. 327 and 328 mixes with the incoming live steam, and thus, condenses a portion of the live steam.

In the compound engine (Fig. 329), the exhaust from the low-pressure cylinder, *L*, does not come in contact at all with the same parts as does the live steam (at boiler pressure). There is, nevertheless, some cylinder condensation in the compound engine due to the temperature difference

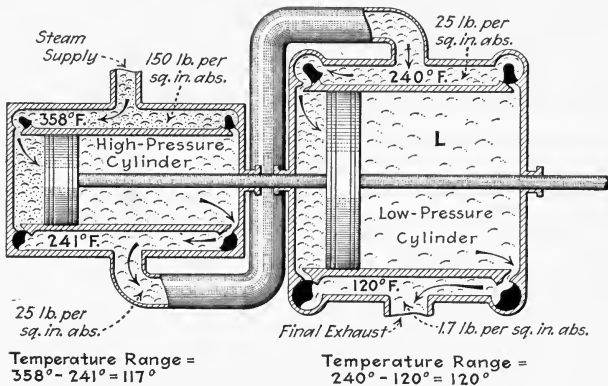

FIG. 329.—Showing temperatures in various parts of a compound engine. (The arrangement shown is, in general, that of a Woolf-tandem compound engine.)

between the incoming and issuing steam in each cylinder. But, because of the lower temperature range in each cylinder, the total condensation is considerably less in the compound engine than in either the single- or four-valve simple engine. It will therefore be evident from a study of the above explanation and of Figs. 327 to 329 that compounding reduces the temperature range in each compound-engine cylinder to approximately one-half of that of a simple engine in which the total temperature range is the same. Similar reasoning will disclose how the temperature range per cylinder may be further reduced by employing three or four cylinders as is done in triple- or quadruple-expansion engines. With a reduction in the temperature range per cylinder, the total cylinder condensation is reduced correspondingly.

NOTE.—THE SURFACES OF THE ENGINE CYLINDER WITH WHICH STEAM, AT VARIOUS TEMPERATURES, CONTACTS ASSUME, at different

instants, very nearly the temperature of the steam at those instants. When a change in steam temperature occurs, the depth to which such a change in temperature will penetrate the cylinder walls will be proportional to the time during which the walls are exposed to the steam at the new temperature. Thus, if a steam stroke is performed in less time, there will be less cylinder condensation. Therefore, the losses due to cylinder condensation decrease as the engine speed increases. Attempts have been made to line cylinder heads with low-heat-conducting materials to prevent cylinder condensation. These materials have all proved to be of insufficient mechanical strength and, therefore, have not been widely used.

275. Why Leakage Past The Piston And Valves Is Less In A Compound Engine Than In An Equivalent Simple Engine may be understood by referring to Figs. 328 and 329. The maximum difference between the pressures on the two sides of the piston and valves in the high-pressure cylinder (Fig. 329) is $150 - 25 = 125$ lb. per sq. in.; and, in the low-pressure cylinder the difference is $25 - 1.7 = 23.3$ lb. per sq. in. Now, in the simple engine (Fig. 328) the pressure difference is $150 - 1.7 = 148.3$ lb. per sq. in. The pressure difference is not much less in the high-pressure cylinder than it is in the simple engine, but the high-pressure cylinder is much smaller for the same power output and the volume of leakage is therefore correspondingly small. Also the steam which leaks past the high-pressure piston is effective in doing work in the low-pressure cylinder.

276. The Mechanical Efficiency Of A Compound Engine Is Ordinarily Greater Than That Of An Equivalent Simple Engine in spite of the greater number of bearings and moving parts of the compound engine. The simple engine, to obtain the same total ratio of expansion as the compound engine, must cut off earlier in its stroke. Fig. 330 shows theoretical engine indicator diagrams. *I* shows the simple engine diagram. *II* shows the combined diagrams (Sec. 281) from the high- and low-pressure cylinders of a compound engine. The mean effective pressures P_2 and P_3 in the compound-engine cylinders are large fractions of the corresponding maximum pressures in the two cylinders. In the simple engine, the mean effective pressure P_1 is only a small part of the maximum pressure, P_0 . The two diagrams show the same total ratio of expansion but

the ratio of expansion (see example under Sec. 273) in the simple engine is 15 whereas that in the compound-engine high-pressure cylinder is only 5. That is, the engine would do the maximum work for which it was designed during only about $\frac{1}{15}$ of the stroke in the simple engine and for $\frac{1}{5}$ of the stroke in the compound engine. The low-pressure cylinder, due to its later cut-off, does its maximum amount of work during half of its stroke. This better distribution of the driving force results in better mechanical efficiency.

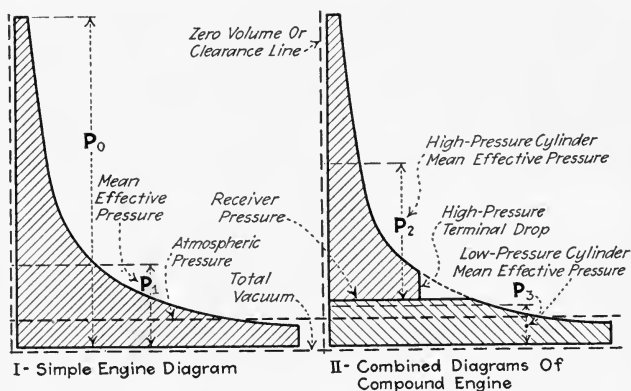

FIG. 330.—Ideal indicator diagrams of compound engine and equivalent simple engine.

277. How The Turning Moment Or Torque Is Made More Even In Compound Engines Of Different Designs may be seen by referring to Figs. 331 to 333. The turning moment of a tandem-compound engine (Fig. 331) is only little more even or regular than that of an equivalent simple engine, although the later cut-off of the compound engine gives a longer maximum turning moment. The torque developed by such an engine is shown graphically in Fig. 331. But, if the high and low-pressure cylinders operate cranks at 90 deg. with each other (as is common in cross-compound engines) the points of maximum torque in the two cylinders will occur 90 deg. apart as shown in Fig. 332. The driving moment on the shaft will then be much more regular and the necessary flywheel size will thus be greatly reduced. If a triple-expansion engine has its three cranks set at 120 deg., the resulting torque

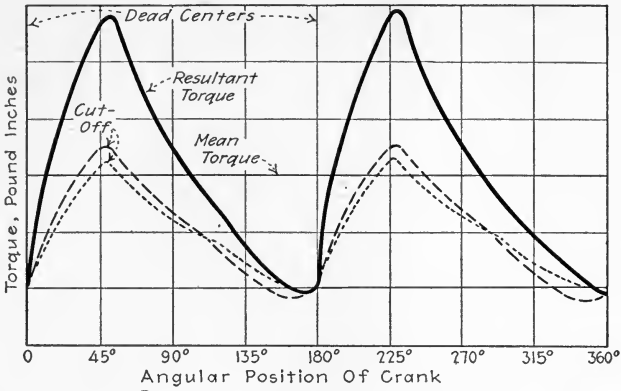

FIG. 331.—Graph showing variation of torque with angular position of crank for a tandem-compound engine.

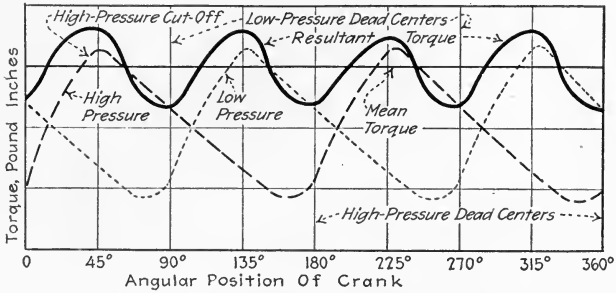

FIG. 332.—Graph showing variation in torque with angular position of crank in a cross-compound engine with cranks at 90 deg.

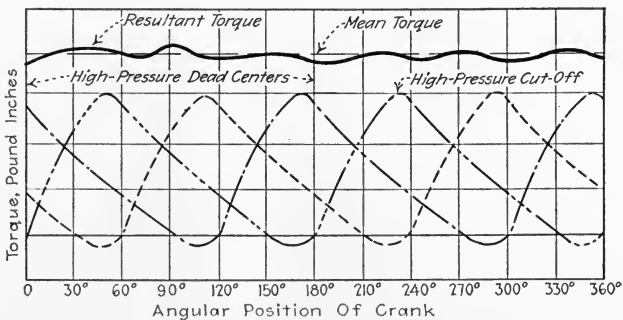

FIG. 333.—Graph showing variation of torque with angular position of cranks of a triple-expansion engine having three cranks set at 120 deg.

graph will be that shown in Fig. 333. An almost uniform turning moment will result.

278. Compound Engines May Be Classified With Respect To The Method Of Transfer Of Steam From One Cylinder To Another as follows: (1) *Woolf-compound engines* (Fig. 334) in which the high-pressure cylinder exhausts directly into the low-pressure cylinder. The cylinders of engines of this class are usually arranged in tandem (Fig. 329) but may also have separate cranks set at an angle of 180 deg. as in Fig. 334. (2) *Receiver-compound engines* (Fig. 335) in which the steam is

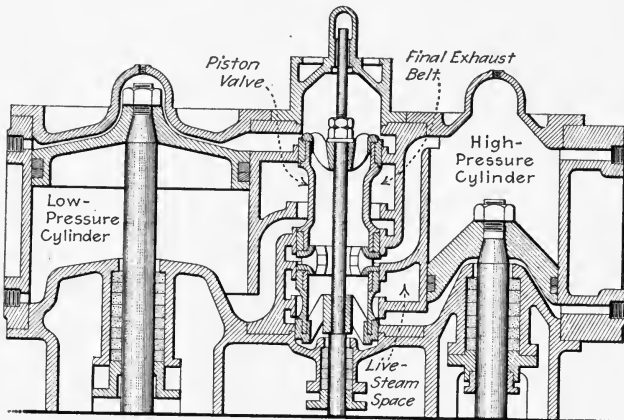
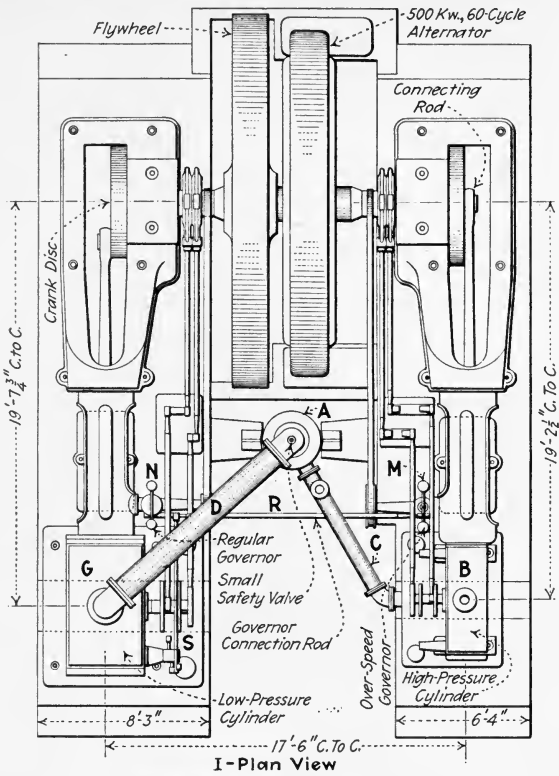
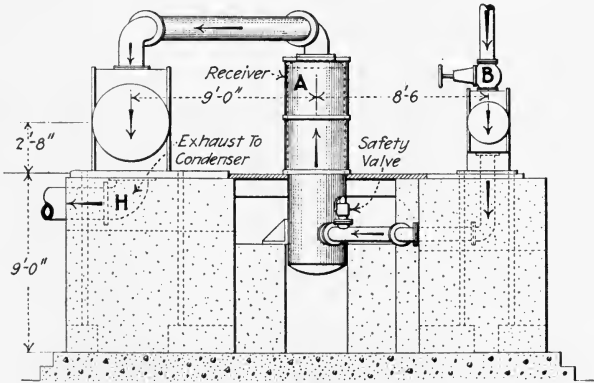

FIG. 334.—Woolf-compound marine engine. The high-pressure cylinder exhausts directly through the piston valve into the low-pressure cylinder. (For complete details of this engine see Fig. 524.)

delivered from the high-pressure cylinder to a receiver and thence to the low-pressure cylinder. All cross-compound engines having cranks at 90 deg. and triple-expansion engines with cranks at 120 deg. are of the receiver-compound type. The reason for this is that, with these cylinder arrangements, the high-pressure cylinder does not exhaust at the proper time to supply the low-pressure cylinder with steam. A receiver, *A*, Figs. 335 and 336, is therefore employed to store, during the intervals between events, the steam from the high-pressure cylinder so that it will be available for supplying the low-pressure cylinder. The receiver may be in the form of a



I-Plan View



II-End Elevation

FIG. 335.—Fulton Iron Works Co. cross-compound, 18 and 36 by 48 in. engine driving alternator. (Steam is admitted to the high-pressure cylinder at B. It is exhausted through C to A where it is reheated. Thence it flows through D to G and is exhausted through H to the condenser. The speed governor, N, is mounted on the low-pressure cylinder, and controls the valves of both cylinders by means of rods, R and S. The over-speed governor, M, prevents the high-pressure valves from picking up when the engine speed exceeds a pre-determined value.)

separate chamber or it may be merely an enlarged pipe connecting the cylinders or an enlarged low-pressure steam chest.

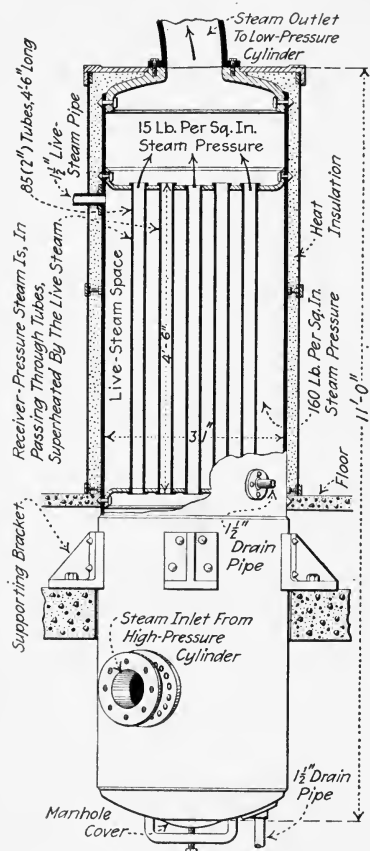

FIG. 336.—Diagram of a combined live-steam reheater and receiver for a 18 and 32 by 42 in. cross-compound engine. (Fulton Iron Works Co. design. This corresponds to receiver, A, Fig. 335.)

NOTE.—THE VOLUME OF A RECEIVER should be at least 1 to 1.5 times the high-pressure cylinder volume for a cross-compound engine with cranks at 90 deg. Receivers having volumes of 5 or more times that of the high-pressure cylinder are sometimes used. For other cylinder arrangements, the receiver may be smaller. Small receiver volumes result in irregular high-pressure exhaust lines, such as those shown at AB in Figs. 337 and 338. Receivers should be provided with pop safety valves to prevent damage in case the receiver pressure rises due to a failure of the low-pressure admission valves to function properly. A drain (S, Fig. 339) should always be provided from every receiver to remove condensed steam. The pressure gage used on a receiver should be of the compound or combination type and should read vacuum and pressure as high as the boiler pressure. A by-pass should be provided for admitting live steam to the compound-engine receiver. This assures that, if the high-pressure crank is on dead center, the low-pressure cylinder may be used to start the engine. The by-pass also permits "warming up" the receiver and low-pressure cylinder before starting the engine.

279. Reheaters Or Interheaters (Fig. 336) are frequently used with compound and usually with triple-expansion engines. A reheater or interheater is a device for heating the steam which is discharged from the high-pressure or intermediate cylinder of an engine before it enters the next lower-

pressure cylinder. Reheaters are usually built in the receiver or take the place of the receiver. The heating may be done with live steam or with furnace gases. With compound

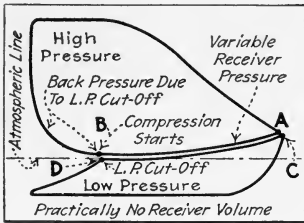

FIG. 337.—Actual indicator diagrams showing decrease in receiver-pressure in a Woolf tandem-compound engine during high-pressure exhaust stroke.

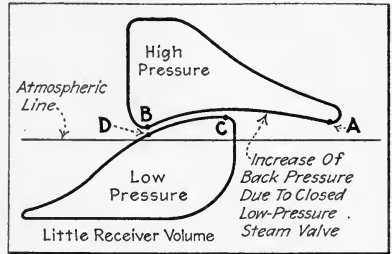

FIG. 338.—Actual indicator diagrams from cross-compound engine showing variation in receiver pressure during exhaust.

engines, a reheater usually does not improve the total thermal efficiency of the engine materially, where the heating is done with live steam, unless the receiver-pressure steam is, by

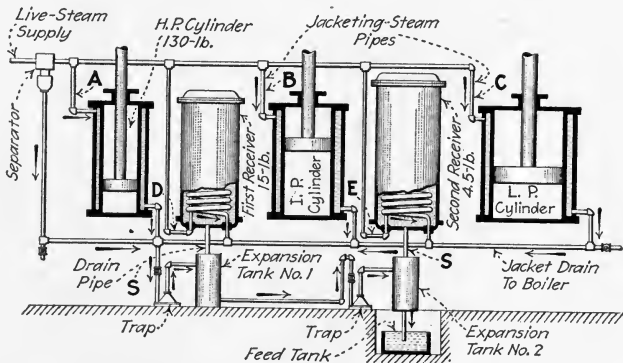

FIG. 339.—Arrangement of receivers and drains on a triple-expansion pumping engine. (H. P. = high pressure cylinder; I. P. = intermediate pressure; L. P. = low pressure. A, B and C are cylinder-jacketing steam pipes. D and E carry live steam for the combined reheaters and receivers.

reheating, superheated about 100 deg. fahr. or more. Reheaters always improve the quality of the low-pressure steam materially and so make the low-pressure cylinder easier to

operate. That is, with steam of greater quality, the operation and lubrication are more positive. Reheaters in which furnace gases are used increase engine economy considerably. Such a reheater is used on the Buckeye-mobile (Fig. 395).

280. The Meanings Of Various Terms Used In Connection With Compound Engines are as follows: The *cylinder ratio* is the ratio of the displacement volume (Sec. 3) of the low-pressure cylinder to that of the high-pressure cylinder. Where the stroke of the two cylinders is the same, the cylinder ratio may be taken for most purposes as the square of the ratio the diameters. Thus, if the high-pressure cylinder is 10 in. in diameter and the low-pressure cylinder is 20 in. in diameter, the cylinder ratio is $(20/10)^2 = 4$ or, as sometimes expressed, it is 4 to 1. In computing the exact value of cylinder ratio the volume occupied by the piston rods must be deducted. The *total ratio of expansion* is the ratio of the final volume of the steam in the low-pressure cylinder to its volume at cut-off in the high-pressure cylinder. Neglecting clearance and, for equal cut-offs in the two cylinders, the total ratio of expansion is the cylinder ratio times the reciprocal of the fraction of stroke completed at high-pressure cut-off. Thus, if cut-off occurs at $\frac{1}{3}$ stroke and the cylinder ratio is 4, the total ratio of expansion is $4 \times 3 = 12$. *Free expansion* is the expansion of the steam in the receiver and passages between cylinders. It is measured by the mean difference between the pressure along the exhaust line of the high-pressure cylinder and that along the admission line of the low-pressure cylinder. *Terminal drop* is the difference between the pressure in the high-pressure cylinder at release and the average receiver pressure.

NOTE.—THE CYLINDER RATIO IN COMPOUND ENGINES VARIES FROM ABOUT 2 TO 1, TO ABOUT 8 TO 1. With a given percentage of cut-off in the high-pressure cylinder, a larger cylinder ratio results in a larger terminal drop. But if a sufficiently early cut-off and a large cylinder ratio are used, the terminal drop may be comparatively small. The economy of the engine will then be high but its power output small in proportion to its weight. If a larger power output is desired at the expense of economy, a later cut-off and smaller cylinder ratio are employed.

281. Two Indicator Diagrams From Each Cylinder Of A Compound Engine May Be Combined, if the diagrams

are taken as specified in Sec. 282 to form a single diagram, Fig. 340. One purpose in so doing is to see how nearly the combined expansion lines, which are thus obtained, conform to the *ideal expansion curve* or to the *saturation line PD* (Fig. 340) for the weight of steam which was admitted to the cylinder. Leaking exhaust and admission valves and leaking pistons may thus be detected in the compound engine, in the same manner as explained in Div. 3 for the simple engine. A convenient method of combining diagrams is, by

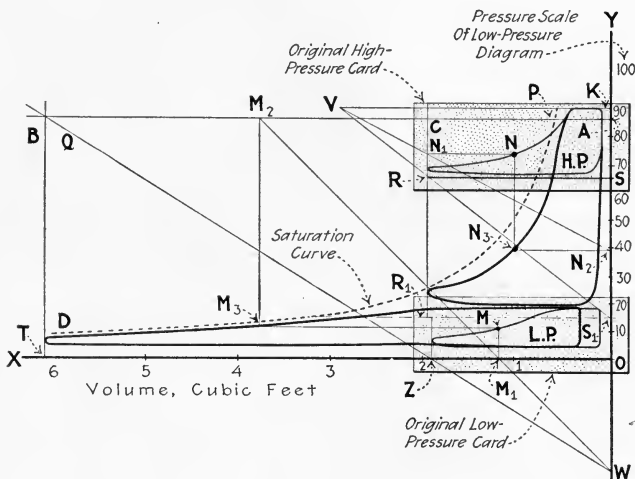

FIG. 340.—Method of combining high-pressure and low-pressure diagrams from a tandem-compound engine. H.P. = high-pressure cylinder; L.P. = low-pressure cylinder.

a graphic means, to increase the volume scale of the low-pressure diagram to the high-pressure-diagram volume scale and to reduce the pressure scale of the high-pressure diagram to the low-pressure diagram scale. The two diagrams will then have the same volume and pressure scales. This method is explained below.

NOTE.—INDICATOR DIAGRAMS WHICH ARE TO BE COMBINED SHOULD BE TAKEN SIMULTANEOUSLY AND WHEN THE LOAD IS CONSTANT. If the diagrams are taken simultaneously with two indicators while the

load is changing, then the combined diagrams may show more steam being delivered to the receiver than is withdrawn from it or vice versa. Where this occurs, the analysis will be misleading. If the two diagrams are taken with one indicator, care should be taken to restore, while taking the second card, exactly the same conditions as obtained for the first card. Furthermore, the conditions should be maintained constant for an interval sufficient to allow the receiver pressure to assume its normal value before either diagram is taken. Combining cards which were taken under different or under changing conditions is a frequent source of erroneous conclusions.

EXPLANATION.—Two lines, OX and OY (Fig. 340), are drawn at right angles, as shown, on a large sheet of paper. A scale of pressures is laid off on OY equal to the spring scale of the low-pressure diagram—for example, 20 lb. per in. The low-pressure diagram, LP , is pasted as shown with its clearance line (see example under Sec. 108) coinciding with OY and its total vacuum line with OX . Locate Z , on OX , even with the end of the diagram. Draw WZQ through Z and any convenient point, W . Now paste down the high-pressure diagram, HP , as shown, so that its clearance line falls on OY and that its highest point, K , is correctly located on the spring scale of the low-pressure diagram. Draw RC as shown. Select point T so that $OT \div OZ = (\text{the displacement volume of the low-pressure cylinder and its clearance}) \div (\text{the displacement volume of the high-pressure cylinder and its clearance})$ or, if the percentage clearances in both cylinders are the same, then $OT \div OZ = \text{the cylinder ratio}$. Draw TB at right angles to OX to intersect WQ . Draw BA through B parallel to OX . Then as many points as desired may be transferred to locate the new low-pressure diagram: Thus, to transfer point M , draw MM_1 , draw WM_1M_2 and project M and M_2 to M_3 ; M_3 is the required point.

Draw, if not already drawn, the atmospheric lines, RS and R_1S_1 . Draw S_1RV and project K to V . Then to transfer any point, N , draw NN_1 and draw VN_1N_2 and project N and N_2 to N_3 . N_3 is the required point on the new high-pressure diagram.

To draw the saturation curve, calculate from test results the weight of steam used per stroke at the load at which the diagrams were taken. That is: $\text{Weight of steam per stroke} = (\text{weight of steam used during test}) \div (\text{number of strokes during test})$. Add to this weight, the weight of steam trapped at compression in the high-pressure cylinder, assuming the steam to be dry. Then find, by using a steam table, the volumes occupied by this total weight of saturated steam at various pressures and plot the volumes and corresponding pressures on the diagram.

NOTE.—THE LOW-PRESSURE EXPANSION LINE OF A COMBINED INDICATOR DIAGRAM is nearly always farther—measured horizontally or along the volume axis—from the saturation graph than is the high-pressure expansion line. This is partly due to the fact that steam is present in the high-pressure cylinder which is not discharged to the receiver but is retained as cushion steam. If, now, the weight of steam retained

in the low-pressure cylinder as cushion steam were the same as that retained in the high-pressure cylinder, the two expansion lines might follow one smooth curve. But, since the weight of steam retained in the low-pressure cylinder is less than that retained in the high-pressure cylinder, the total weight of steam in the low-pressure cylinder is less than in the high-pressure cylinder. Therefore, its volume will be less. That the low pressure expansion line is farther from the saturation graph than is the high-pressure expansion line is also because part of the steam is condensed in the high-pressure cylinder and upon being admitted to the low-pressure cylinder still more of it is condensed. When an interheater or reheater (Sec. 279) is used, the low-pressure expansion line is much nearer the saturation graph. Giving the low-pressure cylinder later cut-off does not, as might be expected, extend the low-pressure expansion line. This is because giving later cut-off in the low-pressure cylinder gives a lower receiver pressure.

NOTE.—COMPOUND-ENGINE INDICATOR CARDS MAY ALSO BE COMBINED TO SHOW THE SIMULTANEOUS CONDITIONS IN BOTH CYLINDERS as suggested in Figs. 337 and 338. For this purpose the volume—horizontal—scales need not be changed. The pressure scales are replotted to a common scale and the simultaneous events for each card are plotted above one another vertically. The line *AB* shows the receiver pressure. The line *CD* shows the pressure of the steam as admitted to the low-pressure cylinder. The vertical distance at any point between *AB* and *CD* shows the pressure drop through the receiver. Hence, such cards are useful in studying receiver pressures and drop.

282. A “Mean Indicator Diagram” Must Be Drawn, If Unlike Indicator Diagrams Are Obtained From The Head And Crank Ends Of Either Engine Cylinder, before the diagrams from the two cylinders can, properly, be combined. This is because some of the steam which passed through the crank end of the high-pressure cylinder will pass through the head end of the low-pressure cylinder if the valves are not adjusted symmetrically as shown by a balanced indicator card. A graphic method of drawing a mean card for an engine cylinder is as follows:

EXPLANATION.—The indicator diagrams, *I* and *II* (Fig. 341), are ruled with vertical equally spaced lines as shown. The clearance lines *M* and atmospheric or total vacuum lines (whichever is most convenient) *WZ* are also drawn. A reference line *XY* is then drawn and vertical lines are drawn as shown twice as far apart as those in *I* and *II*. The sum of the clearances, *WA* and *CZ*, are laid out at *XA*, and the clearance line *XX₁* is drawn. Now to transfer any point *B*, and its corresponding

point, D , to the mean diagram, lay out, with a pair of dividers or other means, the distance A_1D_1 equal to the sum of AB and CD . It will be noted that both the pressure scale and volume scale of the diagram are doubled by this operation.

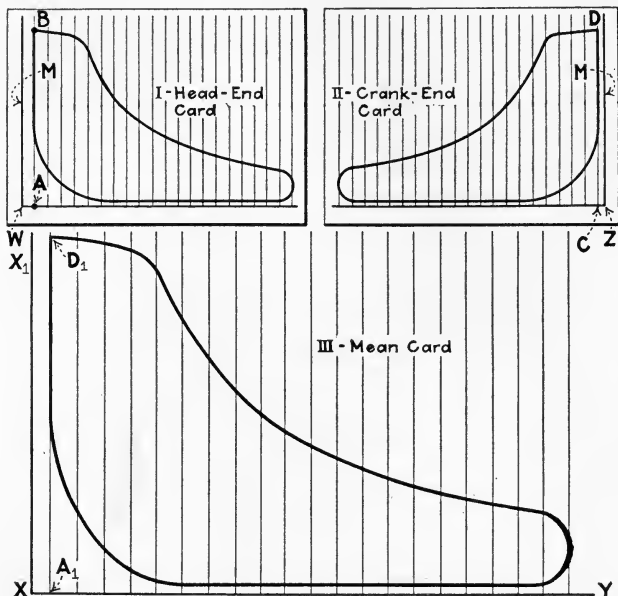

FIG. 341.—Illustrating method of drawing a mean indicator diagram from head-end and crank-end indicator diagrams.

283. The Indicated Horse Power Of Compound Engines may be computed by computing the power of each cylinder and adding the results. The method for computing the horse power of a simple engine was explained in Sec. 123. Each cylinder of a multi-expansion engine may be considered as a simple engine in computing indicated horse power. The cylinder area, the mean effective pressure, and spring scale are ordinarily different in the different cylinders. Therefore little is ordinarily gained by computing the power of the two cylinders together. However, if the diagrams have been carefully combined, as explained in the preceding section, the resulting diagram may be treated as a single diagram in computing indicated horse power.

284. The Receiver Pressure Usually Varies Somewhat During The Stroke of the engine. In Woolf-compound engines (Fig 334) the back pressure on the high-pressure cylinder is a maximum at high-pressure release but falls off rapidly due to the fact that the low-pressure-cylinder volume increases faster than the high-pressure-cylinder volume decreases. This effect is apparent in most tandem-compound engines but is much less if a receiver is used. The high-pressure exhaust line (*AB*, Fig. 338), which also represents the receiver pressure, of a cross-compound-engine diagram usually curves down at its ends due to the low-pressure cylinder admitting steam at the ends of but not in the middle of the high-pressure stroke.

285. With Compound Engines, The Correct Receiver Pressure Must Be Maintained To Insure Economical Operation.—A radically wrong receiver pressure causes most of the work to be done in one cylinder and the engine then gives little better economies than would a simple engine. But even when the receiver pressure is varied within apparently reasonable limits, there may be a difference of 10 per cent. or more in the steam consumed by the engine per indicated horse power hour due to these receiver pressure differences. The receiver pressure recommended by one manufacturer for non-condensing compound engines is about 30 lb. per sq. in. gage and for condensing operation, about 15–20 lb. per sq. in. gage.

286. To Find The Best Receiver Pressure For Any Receiver-Compound Or Multi-Expansion Engine, find the receiver pressure at which the net work done in the cylinders is equal. This can be accomplished by taking successive indicator cards at the same load from each cylinder and varying the receiver pressure. Then the power (see Sec. 123) developed by each cylinder with each receiver pressure is determined. The best receiver pressure is, of course, that at which the economy of the engine is maximum. But nearly all compound engines are so designed that the work in the two cylinders is about equal when economy is maximum. Therefore, if the work done by the several cylinders is equal, it may, ordinarily, be assumed that the receiver pressure is correct. In a

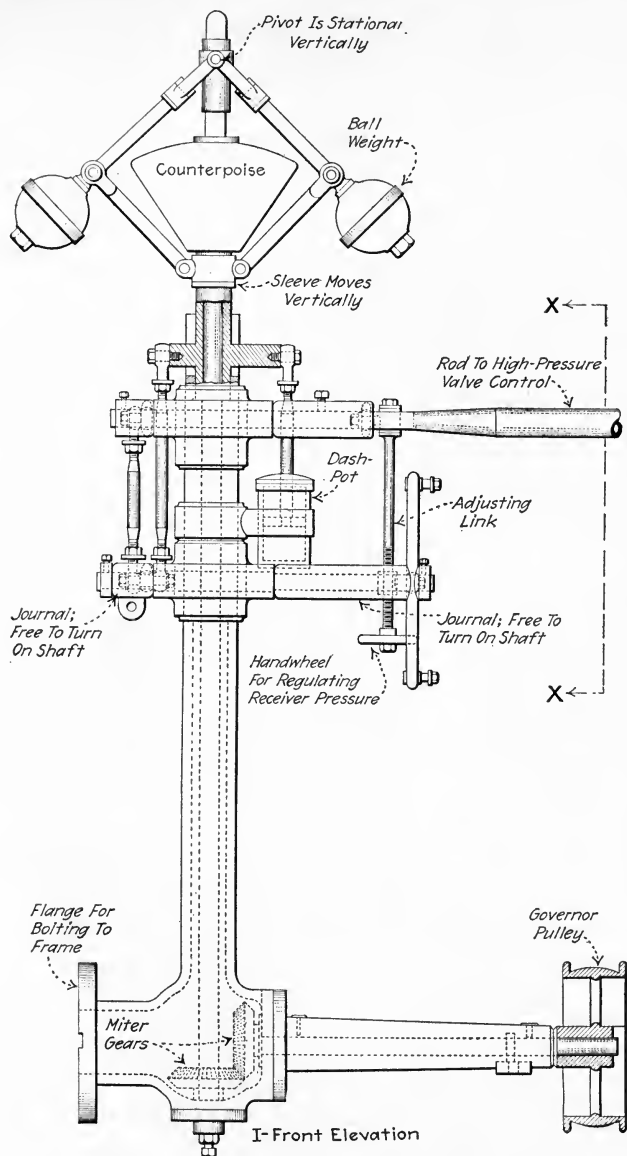

FIG. 342.—Cross-compound Corliss engine governor, *N*, Fig. 335 showing receiver-pressure regulation device. (Fulton Iron Works Co. design). This governor is located on the low-pressure cylinder and controls the regular knock-off cams on both cylinders.

combined diagram, the work areas may be directly compared. When it is desired to establish as nearly as possible the correct receiver pressure before taking indicator diagrams, the rules given in the following section may prove useful.

287. The Receiver Pressure For A Compound Engine Depends On The Cylinder Ratio.—For condensing operation, the receiver pressure should be approximately the absolute boiler pressure divided by the cylinder ratio. Thus, if there is a steam supply pressure of 185 lb. per sq. in. abs. and a cylinder ratio of 5 (5 to 1), the receiver pressure should be about: $185 \div 5 = 37$ lb. per sq. in. abs. or about 22 lb. per sq. in. gage. For non-condensing operation, the receiver pressure should be approximately the geometric mean between the absolute steam-supply pressure and the absolute back pressure. The geometric mean between two values is the

square root of their product. Thus, if there is a line pressure of 135 and a back pressure of 15 lb. per sq. in. abs., the receiver pressure should be: $\sqrt{15 \times 135} = 45$ lb. per sq. in. abs. or about 30 lb. per sq. in. gage.

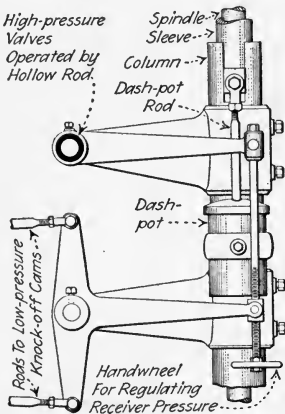

FIG. 343.—Side view of governor mechanism for the cross-compound engine of Fig. 335. This is view XX, Fig. 342.

288. The Governor Gear Adjustment (Figs. 342 and 343) may be used to vary the receiver pressure in those compound Corliss engines which change the cut-off in both cylinders by means of a single governor. If the low-pressure-cylinder cut-off is made later relative to that in the high-pressure cylinder, then the receiver pressure will be

lowered and the low-pressure cylinder will then do less work. Conversely, if the low-pressure-cylinder cut-off is made earlier relative to that in the high-pressure cylinder, the receiver pressure will be raised and the low-pressure cylinder will do more work. After making any valve-gear adjustments, it is well to see whether the receiver pressure is correct. If it is not correct, the linkage between the cams of the two cylinders should be

adjusted to give the correct pressure. There will be some variation in receiver pressure with load with this arrangement (see Fig. 344) but not as much as when only the high-pressure cylinder is governed (Fig. 345).

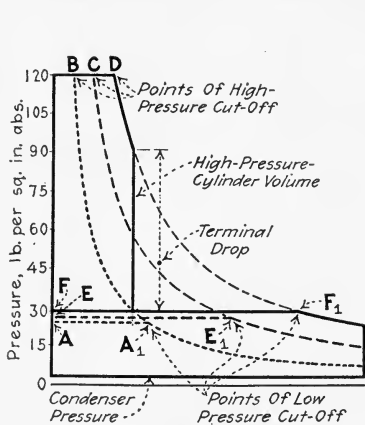

FIG. 344.—Theoretical indicator diagrams showing variation in receiver pressure due to cut-off governing in both cylinders. The lines FF_1 , EE_1 , and AA_1 represent respectively the different receiver pressures.

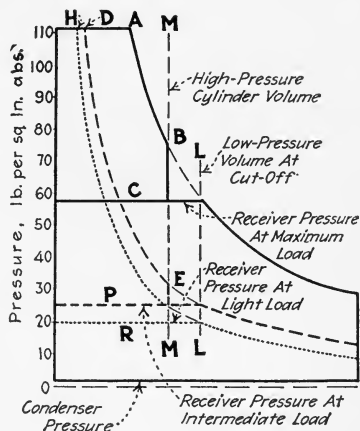

FIG. 345.—Theoretical indicator diagrams showing effect of Governing high-pressure cylinder only.

289. Where Only The High-Pressure Cylinder Is Governed, the cut-off in the low-pressure cylinder is fixed. The receiver pressure will then vary with the load. The low-pressure-cylinder cut-off should therefore be set at a point which will give the proper receiver pressure under the average load expected.

EXPLANATION.—Fig. 345 shows theoretical indicator diagrams from a compound engine which is governed by changing the cut-off in the high-pressure cylinder only. The low-pressure cut-off is fixed at LL . When high-pressure cut-off is late as at A , the steam expands only to B before it attains the volume MM of the high-pressure cylinder. This amount of steam at the cut-off volume LL of the low-pressure cylinder exerts a pressure C , which is therefore the receiver pressure at this load. Similarly, the receiver pressures P and R are produced when cut-off occurs at D and H . In the diagrams of Fig. 344, cut-off occurs at B , C , and D . The low-pressure cut-off is varied by the governor so as to occur at A_1 , E_1 and F_1 . This governor action varies the receiver pressure but little and keeps the work in the two cylinders about equal.

290. Triple- And Quadruple-Expansion Engines Are Rarely Used In Stationary Power Plants except in large existing pumping stations. New pumping stations use turbine-driven centrifugal pumps for large-capacity pumping service. But multi-expansion engines are built extensively for marine service. Fig. 346 shows a typical triple-expansion marine engine. Two low-pressure cylinders, L_1 and L_2 , are used to

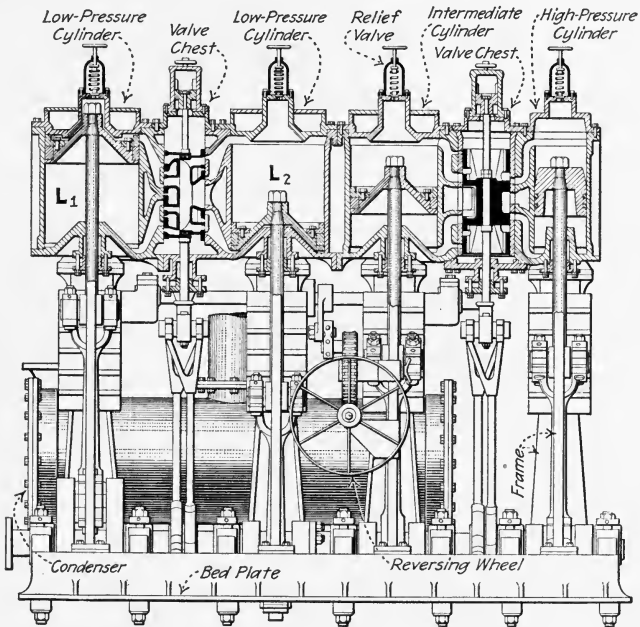

FIG. 346.—Four-cylinder triple-expansion marine engine.

secure proper mechanical balance. The combined indicator diagrams from a quadruple-expansion engine are shown in Fig. 347.

291. To Set The Valves Of A Compound Engine, set the valves of each cylinder separately. The high-pressure valves may be set as explained for simple engines in Divs. 4 and 5. The low-pressure valves should be given more lead than those of the high-pressure cylinder. About $\frac{1}{16}$ to $\frac{5}{64}$ in. per foot of stroke is advisable for most compound-engine low-pressure valves. For vertical engines, it is advisable to give little more

lead on the bottom than on the top of the cylinder. Where the valves are very quick acting, it may be more convenient to set them in relation to the angular position which the crank assumes at the instant when the admission valve begins to open, rather than to set for lead. On the low-pressure cylinder, the valve should start to open when the crank is 7 to 10 deg. ahead of dead center. This *angular lead* may, however, be as high as 15 deg.

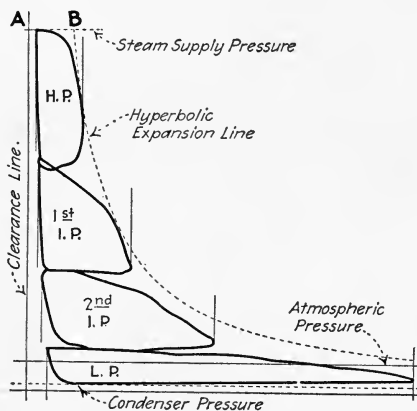

FIG. 347.—Combined indicator diagrams from a quadruple expansion engine.

QUESTIONS ON DIVISION 8

1. Name two conditions under which compound engines are commonly used.
2. Over what pressure ranges are compound engines commonly operated? When are simple engines almost as economical as compound engines? What saving in steam may be expected from the use of a compound engine operated condensing over the steam consumption of a simple condensing engine?
3. Give the four principal advantages of compound engines.
4. Show by a sketch how the live steam comes in contact with the same parts as does the exhaust steam in a simple engine. Why does not this occur in a compound engine?
5. How do engine speed and the heat conductivity of the cylinder wall affect cylinder condensation?
6. Explain how the loss due to leakage past the cylinder and valves is lessened in a compound engine.
7. Why is the mechanical efficiency of a simple engine employing a large ratio of expansion less than that of an equivalent compound engine?
8. What is torque? How is it measured? Why is the torque very uniform in a triple-expansion engine with cranks at 120 deg.? Which do you consider preferable, a tandem- or a cross-compound engine? Why?
9. How may compound engines be classified with respect to the steam flow? Why is a receiver necessary in a cross-compound engine with cranks set at 90 deg.?
10. How large should a receiver for a cross-compound engine be? With what accessories and pipes should it be equipped?

11. What are two principal kinds of reheaters?
12. What is the *cylinder ratio* of a compound engine? What is *free expansion*? *Terminal drop*?
13. What cylinder ratios are used in compound engines? How is engine economy affected by larger cylinder ratios and earlier cut-off? How does this affect power output?
14. Explain by a sketch how indicator diagrams from high- and low-pressure cylinders of a compound engine may be combined.
15. What causes the low-pressure expansion line of a combined indicator diagram to fall farther from the saturation line than does the high-pressure expansion line?
16. How may the indicated horse power of multi-expansion engines be computed?
17. Explain how the receiver pressure varies during a stroke in a cross-compound engine.
18. How may the correct receiver pressure for an engine be determined by means of a steam engine indicator?
19. Which method of compound-engine governing gives the greatest variations in receiver pressure? Why?
20. How much lead should there be in the valves of a low-pressure cylinder of a compound engine?

PROBLEMS ON DIVISION 8

1. Approximately what receiver pressure should a compound condensing engine have when taking steam at 150 lb. per sq. in. gage if the cylinder ratio is 4.3:1. What should be the receiver pressure for a non-condensing compound engine taking steam at 100 lb. per sq. in. gage and exhausting at 5 lb. per sq. in. gage?
2. If the crank arm in a simple engine is 6 in. long and the cylinder diameter is 10 in., what maximum torque can the piston exert on the shaft if the effective pressure on the piston is 150 lb. per sq. in.? Assume that, when the crank and connecting rod are at right angles to each other, the force on the crank pin is 90 per cent. of that on the piston.
3. If, in a quadruple-expansion engine, the temperature ranges in all cylinders are equal, and if steam is supplied to the engine at 225 lb. per sq. in. gage and exhausted into a condenser where the vacuum is 28.5 in. of mercury column, what is the temperature range in each cylinder? Barometer = 30 in.
4. A compound engine, which has a cylinder ratio of 4.5:1 cuts off at 26 per cent. stroke in the high-pressure cylinder. Neglecting clearance, what is its ratio of expansion? If there is 6 per cent. clearance in each cylinder, what is the ratio of expansion?
5. If a compound engine has a stroke of 5 ft., what lead should its low-pressure cylinder admission valves have?

DIVISION 9

CONDENSING AND NON-CONDENSING OPERATION

292. By Condensing Operation Of A Steam Engine Is Meant Its Operation In Connection With A Steam Condenser So That A Pressure Considerably Below Atmospheric Pressure Is Maintained In The Engine Exhaust Pipes And Passages. That is, the back pressure on an engine operated condensing

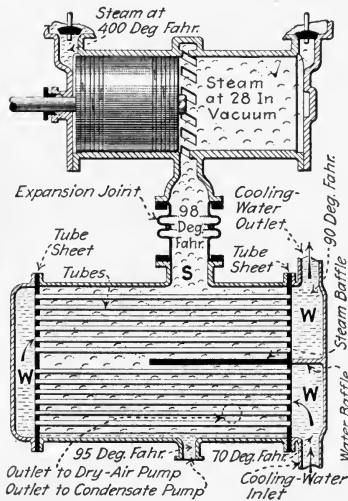

FIG. 348.—Diagram of uniflow-engine cylinder connected through expansion joint to surface condenser.

(Fig. 348) is ordinarily 10 to 14 lb. per sq. in. below atmospheric pressure, while that on one operated non-condensing is usually 0 to 5 lb. per sq. in. above atmospheric pressure.

NOTE.—A CONDENSER IS A CHAMBER WHEREIN THE EXHAUST STEAM FROM THE ENGINE IS COOLED AND THEREBY CONDENSED INTO WATER. A partial vacuum, into which the engine (Figs. 349 and 350) exhausts, is thus formed. The subject of condensers is treated quite fully in the author's STEAM POWER PLANT AUXILIARIES AND ACCESSORIES.

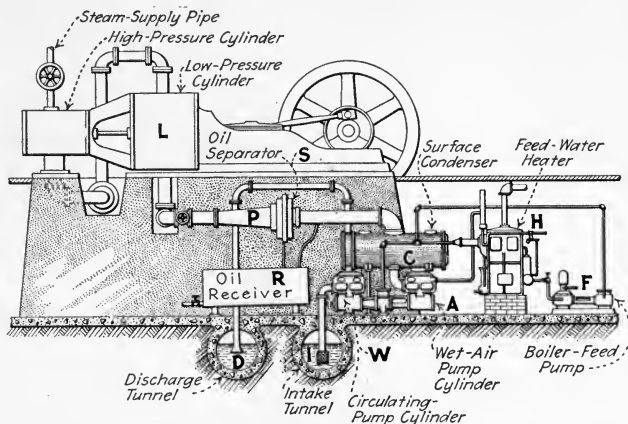

FIG. 349.—Surface condenser connected for service with tandem-compound engine. Steam is discharged from low-pressure cylinder, *L*, through *P*. The cylinder oil and water are removed by *S* and collected in *R*. The steam is condensed in *C* by water, which is sucked from *I* by *W* and discharged into *D*. The air and condensate are removed by *A*, the latter being heated in *H* and fed back to the boiler by *F*. (*Cochrane Heater Catalogue.*)

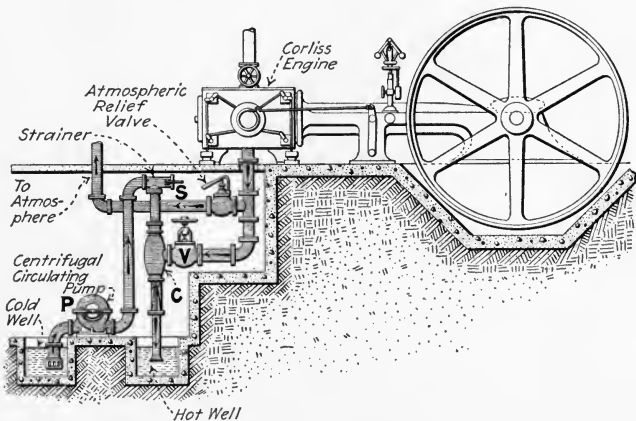

FIG. 350.—Ejector-jet condenser installed for service with simple Corliss engine. *Schutte & Koerting Co. catalogue*; water is circulated by *P* through *S* and the condenser *C*. The velocity of the water issuing from jets in *C* is such that water and air are discharged from the vacuum in *C* against atmospheric pressure.)

293. The Main Purpose In Reducing The Back Pressure On A Steam Engine By Means Of A Condenser Is To Save Steam And Thus Save Coal.—That is, an engine will develop a given amount of power from less steam if a condenser is used; or, conversely, it will develop more power on a given amount of steam when a condenser is used.

EXPLANATION.—Fig. 351 represents an ideal condensing engine indicator diagram (Sec. 78) superimposed on a corresponding non-condensing diagram. The steam pressure is represented by line PP' ; atmospheric pressure by line AA' ; and zero pressure or complete vacuum by VV' . Consider first that the same volume of steam, S_2 , is used for both condensing and non-condensing operation, and that this steam expands as represented by line RS . Then, area $PRSB'BP$ represents the work done

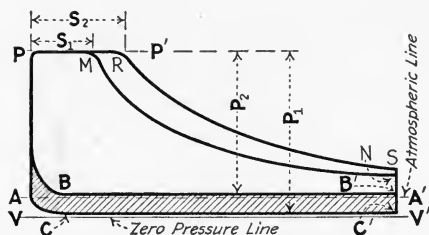

FIG. 351.—Ideal indicator cards showing comparative work areas, working pressures, and steam consumptions for condensing and non-condensing operation.

by the engine running non-condensing; area $PRSC'CP$ represents that done condensing. The shaded area represents the increased work done when running condensing over that when running non-condensing. P_1 represents the working pressure range with the condenser as compared to P_2 without it. The engine thus develops more power from the same amount of steam when operated condensing.

But assume that by an earlier cut-off less steam, S_1 , is admitted to the cylinder so that the expansion follows the new line MN . S_1 is assumed to be of such an amount that the work area $PMNC'CP$ is equal to the area $PRSB'BP$. Then the shaded area is equal to the area $MNSR$, and the work done by a volume of steam S_1 with condensing operation is equal to that done by a volume of steam S_2 with non-condensing operation. Thus the same amount of work is done by less steam with condensing operation.

NOTE.—METHODS OF CALCULATING THE PERCENTAGE SAVING OR POWER INCREASE DUE TO CONDENSING OPERATION are given in the author's STEAM POWER PLANT AUXILIARIES AND ACCESSORIES.

294. Condensing Operation Is Not Economical For Any Engine When Most Of The Exhaust Steam From The Engine Can Be Profitably Used For Heating Or Industrial Purposes. It is much more economical to use exhaust steam for heating than to condense the exhaust and heat with live (boiler-pressure) steam. When all of the exhaust steam from an engine is used for heating, the engine merely acts as a reducing valve and furnishes power as a sort of by-product. On the other hand, when the exhaust is condensed, much heat is absorbed by the condensing water and is lost. In general, the exhaust from an engine should be condensed only when it cannot be used.

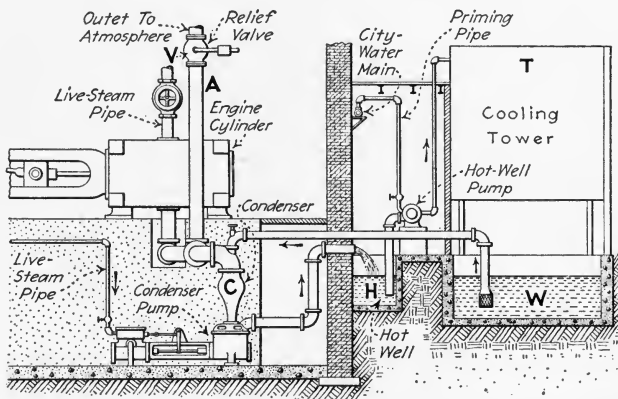

FIG. 352.—Low-level jet condenser and condenser pump connected to engine and cooling tower. (Water is pumped by the hot-well pump from *H* to the top of *T*, and flows by gravity to *W*. If the condenser, *C*, fails to work, *V* opens and the engine exhausts to the atmosphere through *A*. The heat absorbed by the water in *C* is removed by evaporation in *T*.)

NOTE.—SINCE CONDENSING OPERATION REQUIRES CONSIDERABLE RELATIVELY COLD WATER, IT IS ONLY FEASIBLE WHERE THERE IS AN ADEQUATE WATER SUPPLY. In practice 25 to 100 lb. of water are required for each pound of steam condensed. Water for a condenser may be recoiled in a cooling tower (Fig. 352) or pond and used repeatedly.

295. Table Showing Average Steam Consumptions Of Various Types Of Engines Operated Condensing And Non-Condensing At Full Load. (Based on data from O. B. Goldman's FINANCIAL ENGINEERING.)

Engine	Saturated steam at 150 lb. per sq. in. pressure			Superheated steam at the same pressure, 100 deg. Fahr. superheat		
	Pounds of steam per i.h.p. hr.		Per cent.	Pounds of steam per i.h.p. hr.		Per cent.
	Non-cond.	Cond.*	Saving	Non-cond.	Cond.*	Saving
Simple, high-speed, single-valve, 18 in.-stroke	27.6	25.7	7			
Simple, four-valve, 18-in. stroke....	24.1	19.8	18			
Compound 18-in. stroke.....	22.0	14.8	33	17.0	12.7	25
Uniflow 18-in. stroke.....	20.8	17.1	18	18.3	15.0	18

* The condensing operation is at 26 in. of mercury vacuum.

NOTE.—The steam consumptions of the condenser auxiliaries are not included in the above values. The condenser auxiliaries, when steam driven, ordinarily consume about 1 to 6 per cent. as much steam as is consumed by the main engine.

296. Cylinder Condensation Is Of Importance In Determining Whether Condensing Or Non-Condensing Operation Is The More Economical.—The efficiency loss due to cylinder con-

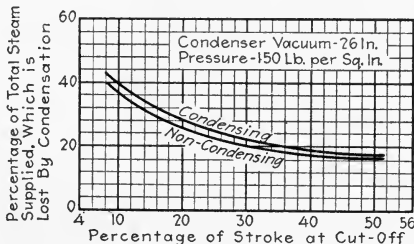

FIG. 353.—Graph showing that, with condensing operation of a simple engine, the loss due to cylinder condensation is greater than with non-condensing operation; and that it increases as the cut-off becomes earlier. (The percentage loss is greater in smaller engines. The increased loss due to condensing operation is greater when the steam pressure is less. The values were calculated by a formula by R. C. H. Heck.)

denation (Sec. 307) in a simple engine (Figs. 353 and 354) is increased by condensing operation. The live steam in a simple engine is admitted to the space which was recently occupied by steam at condenser pressure. The live steam may have a

temperature 300 deg. fahr. or more above that of the condenser-pressure steam; see a steam table for temperatures of steam at different pressures. The live steam (as explained in Sec. 274) must heat the cylinder walls to nearly its own temperature. In heating the cylinder walls, the live steam is cooled and thereby partially condensed which results in a heat loss. In compound engines (Div. 8), the difference in

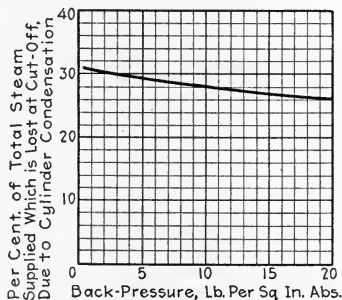

FIG. 354.—Graph showing that, as the back pressure on a simple engine is reduced—or as the vacuum is increased—the loss due to cylinder condensation becomes greater. (Simple engine 18 × 12 in. Steam pressure 100 lb. per sq. in. gage. Speed 175 r.p.m. Cut-off at 20 per cent. stroke. Calculated by a formula by R. C. H. Heck.)

temperature between the incoming and outgoing steam in each cylinder is usually much less than in a simple engine. Uniflow engines (Fig. 348) are so constructed that the cool condenser-pressure steam is exhausted in the center of the cylinder whereas the live steam is admitted at the ends. This prevents, in a measure, the cooling of the cylinder ends by the exhaust steam. Compound and uniflow engines are therefore able to get the benefit of the increased working pressure effected by a condenser without incurring excessive loss due to cylinder condensation.

297. The Chief Advantages And Disadvantages Of Condensing Operation are as follows:

CONDENSING	NON-CONDENSING
<i>Advantages</i>	<i>Disadvantages</i>
<p>Decreases steam consumption of large engines 20 to 40 per cent.</p> <p>Recovers most of the feed water unless a jet condenser is used with impure water. The recovered feed water is usually 50 deg. fahr. hotter than fresh feed.</p> <p>Increases power output of a given installation or decreases necessary size of installation for given power output.</p> <p>Converts heat, which would otherwise be wasted, into work.</p>	<p>Requires more steam.</p> <p>Must use fresh feed water which may be expensive to heat and purify.</p> <p>Requires larger boiler installation.</p> <p>Wastes most of the exhaust steam unless it can be used for heating.</p>
<i>Disadvantages</i>	<i>Advantages</i>
<p>Requires additional equipment, * <i>i.e.</i>, condensing, pumping and water recooling equipment.</p> <p>Operation more difficult.</p> <p>No steam available for heating.</p> <p>Difficulty in keeping joints tight and maintaining additional equipment.</p>	<p>Relatively low first cost.</p> <p>Operation relatively simple.</p> <p>Exhaust steam available for heating.</p> <p>Fewer joints to keep tight.</p>

* In condensing plants these auxiliaries are often steam driven and their exhaust steam is used to heat the feed water. This arrangement lessens the disadvantages of the extra equipment.

298. The Most Profitable Degree Of Vacuum Is Greater With A Uniflow Engine Than With Simple Or Compound Counterflow Engines.—The most profitable degree of vacuum for uniflow engines is the highest vacuum that may be reasonably maintained. The most profitable degree of vacuum for compound counterflow engines is about 26.5 in. of mercury (or about 88 per cent. of a complete vacuum). Further

decrease in back pressure is not warranted for these reasons: (1) *The power required by the condenser pumps would rapidly increase.* (2) *Economy would not materially increase.* (3) *Leaks become troublesome.* (4) *Cylinder condensation is very great.*

NOTE.—The subjects of starting, stopping and maintaining condensers are treated in Div. 13.

299. The Chief Application Of The Condensing Engine Is For Electric Power Plants Which Have A Limited Supply Of Water, And For Driving Slow-Moving Machinery Which Cannot Be Turbine Driven.—Large modern power plants are, whenever possible, located on a lake or river or arm of the ocean so that there is an abundant supply of cooling water. Such plants nearly always employ turbines, which operate with a higher vacuum than is profitable with engines, and better economies are thus obtained than with condensing engines. Smaller plants which are not so located may employ condensing engines and re-cool the condensing water in a cooling tower or pond. Since the principal use of the turbine is for driving machinery which permits of high rotative speeds (for example, generators and centrifugal pumps), its application would not be suited to mills and other plants where direct, belt or rope driving is employed. In such plants the condensing engine is commonly used for steam power generation even though the supply of water is adequate for economical condensing turbine operation.

QUESTIONS ON DIVISION 9

1. What is meant by *condensing operation*? How is it accomplished?
2. Explain by a diagram how more power is developed from the same amount of steam by condensing operation.
3. What saving is effected by condensing operation of large compound engines? What is the proportion of the steam required by the main engine to that used by the condenser auxiliaries?
4. When is the condensing operation of any engine less economical than non-condensing operation?
5. How does cylinder condensation affect the economies of engines of various kinds when operated condensing?
6. Enumerate the chief advantages and disadvantages of condensing operation.
7. What percentage of a total vacuum is ordinarily profitable in a condenser for a compound engine?
8. Give two conditions under which condensing engines are commonly used.

DIVISION 10

STEAM-ENGINE EFFICIENCIES AND HOW TO INCREASE THEM

300. The Steam Engine Converts Into Mechanical Work Only A Relatively Small Part Of The Total Heat Supplied To It; see Sec. 6. Under some conditions, the heat which is not converted into work may be usefully employed. Under such conditions as will be explained later, the fact that the engine converts into mechanical work only a small part of the heat energy which it receives becomes of comparatively little consequence. Under other conditions, it is of great commercial importance. For example, the steam locomotive seldom converts into mechanical work over 10 per cent. of the total heat supplied to it. The remaining 90 per cent. or more produces no useful effects in the locomotive and represents a total loss. Why a large part of such loss is unavoidable, and how the avoidable parts of it may be reduced, constitute the subject of this division. See also the portions of Div. 12 which relate to efficiency.

NOTE.—THERE IS NO POSSIBLE WAY IN WHICH THE EFFICIENCY OF AN ENGINE, WHICH IS ALREADY INSTALLED UNDER GIVEN OPERATING CONDITIONS AND WHICH IS IN GOOD REPAIR, CAN BE GREATLY INCREASED. If the valves and pistons of an engine have only a negligible leakage (Div. 13) and the engine is properly adjusted (Divs. 4 and 5), cleaned, lagged, and lubricated (Div. 16) the operator has ordinarily no further responsibility for its efficiency. It is sometimes possible, where the design of the engine permits, to change to condensing operation, to superheated steam, or to higher boiler pressure, in order to increase engine efficiency. However, these operating conditions are usually so determined in a plant that they cannot be changed without completely rebuilding the plant. When an engine is first selected it should, therefore, be so chosen that it will give the desired efficiency without its being necessary later to alter other plant equipment. Therefore, the efficiency of an engine, assuming good maintenance and correct application, depends entirely on its design. In general, the efficiency of an existing

steam-power plant can be improved by giving detail attention to the boiler room rather than to the engine room. It is in the boiler room that a great part of the correctable wastes occur.

301. Why A Large Part Of The Losses In A Steam Engine Are Unavoidable may be understood by a study of the hydraulic analogy of Fig. 355. Fall in temperature, representing as it does loss of heat or loss of energy, is compared to fall of water, which represents loss of *head* or of its potential energy of position. The steam engine, A, can operate non-condensing over only a certain temperature range, just as a water-power

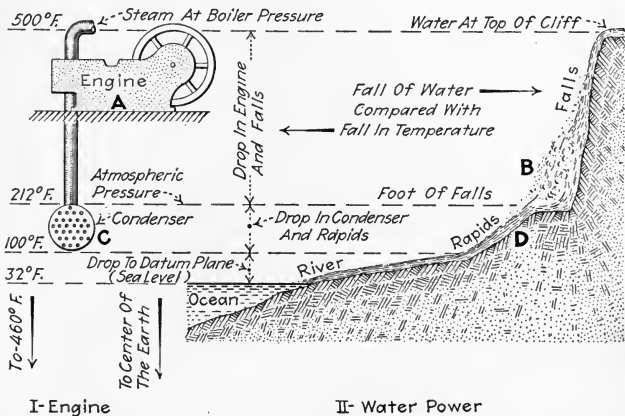

FIG. 355.—Showing analogy between water-power utilized and heat utilized by steam engine.

plant can utilize only the hydraulic head of the water fall, B. By adding the condenser, C, an additional range in temperature may be utilized just as the fall in the rapids, D, might be utilized by the water-power plant by means of additional piping. But it is just as impractical to cool to 32 deg. fahr. in the condenser as it is, ordinarily, to pipe water to sea level to utilize the final drop or head to that datum plane.

EXPLANATION.—At 32 deg. fahr. water is, for steam engineering purposes, considered to contain no heat just as water at sea level is considered to have no potential energy. There is a large theoretical temperature range to absolute zero (-460 deg. fahr.) just as there is a large theoretical hydraulic drop from sea level to the center of the earth. But,

to use the temperature range below 32 deg. fahr., mechanical refrigeration must be employed; and to use water power below sea level, the water must be pumped back to its original level. In either case, no additional power would be developed. It follows that, although only a small part of the total absolute temperature range (and therefore of the total heat) is useful in the steam engine, the remainder is of such nature that little of it can be utilized.

302. It Is Often Unwise To Increase Engine Economy At The Expense Of Greater Fixed Or Maintenance Charges. Fixed charges are taxes, insurance, the interest on the capital invested and depreciation or the amount of money which must be laid aside yearly to replace the engine when it is no longer useful (see Div. 15). Steam-engine operation is, ordinarily, a commercial undertaking—increased fixed or maintenance charges may increase total power plant expense as much as do increased fuel costs due to poor engine efficiency. Therefore engines are not, necessarily, built or operated with a view to securing the greatest possible thermal efficiency. Instead, they should be built and operated to provide the maximum economy, when *all* factors of cost are considered. Thus, while higher initial steam temperatures used with larger ratios of expansion and higher vacua increase thermal efficiency, such methods of increasing economy are limited by the other costs involved. In general (see Div. 15), the fixed charges on an engine should be much less than the cost of the fuel; and the engine maintenance charges should be a small fraction of the total expense of the engine during its life.

303. The Losses In A Steam Engine May Be Divided Into Three Classes (see Div. 1): (1) *Rejection losses* or heat which it is not possible for a commercial steam engine to use. Since these rejection losses are largely dependent on the kind of cycle on which the engine operates, their amount will be considered quantitatively in Secs. 314 to 316 under the Rankine cycle. The rejection "losses" are often not lost at all. All of the heat thus rejected is present in the exhaust steam and may frequently be used for steam heating. (2) *Thermal losses* (Sec. 309). These losses nearly always constitute actual losses because the heat thus lost is too widely diffused to be useful.

(3) *Mechanical losses* (Sec. 310). These losses subtract from the mechanical work which has been derived from the heat; and convert part of the work back into heat in the bearings where it is useless and particularly undesirable.

NOTE.—IN A STEAM ENGINE, THE PERCENTAGE LOSSES ARE A MINIMUM AT OR NEAR RATED FULL LOAD (Fig. 356). At a considerable

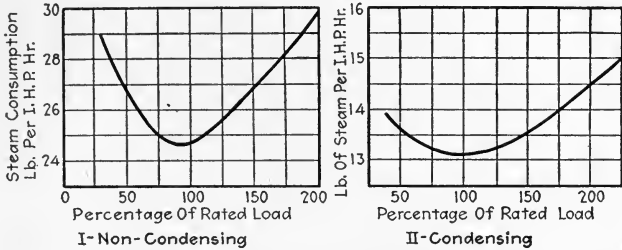

FIG. 356.—Variation in steam consumption of uniflow engine with variation in load. (Nordberg engine, saturated steam.)

overload, the rejection losses are large due to the incomplete expansion. At light loads, the mechanical and thermal losses, which do not vary greatly with change in load, become larger in proportion to the power output. As engines are usually designed to secure the greatest efficiency at or near full load, it follows that, in actual practice, one of the principal methods of maintaining engine efficiency at a maximum is to keep the

load as near normal (rated full load) as is possible. It also follows that in power plants the units should be so selected that they may be operated at or near full load most of the time (see Div. 15).

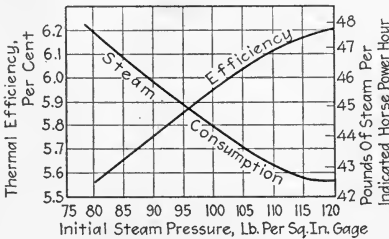

FIG. 357.—Graph showing the effect of increasing boiler pressure on the efficiency of a small high-speed non-condensing engine.

304. The Six Principal Methods Of Decreasing The Percentage Rejection Losses Of A Steam Engine

are: (1) *Increasing boiler pressure* (Fig. 357, see note below). (2) *Superheating the steam* (Fig. 358, see Div. 14). (3) *Condensing* (see Div. 9). (4) *Compounding* (see Div. 8) or *improving the steam flow by four-valve and uniflow features* (see Div. 11). (5) *Varying rotative speed*. Relatively slow speed is an inherent limitation of steam engines; hence the speed cannot, usually,

be greatly increased. The most efficient speed for an engine is ordinarily near its rated speed. The practical speed limit for steam engines (except very small ones) is about 300 r.p.m. Higher speed decreases cylinder condensation but increases wire-drawing in the valves and steam ports. To avoid this latter effect, the valves of higher-speed engines are made larger. (6) *Decreasing clearance and increasing ratio of expansion* (Sec. 305). Too small clearance is dangerous since with small clearance, a very little water in the end of the cylinder might cause the cylinder head to be blown out or the piston or rod to be crushed. Increasing the ratio of expansion so decreases the power output of an engine that the practical limit for this

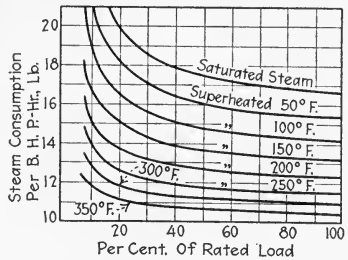

FIG. 358.—Graph showing the effect of superheating on the efficiency of a simple engine.

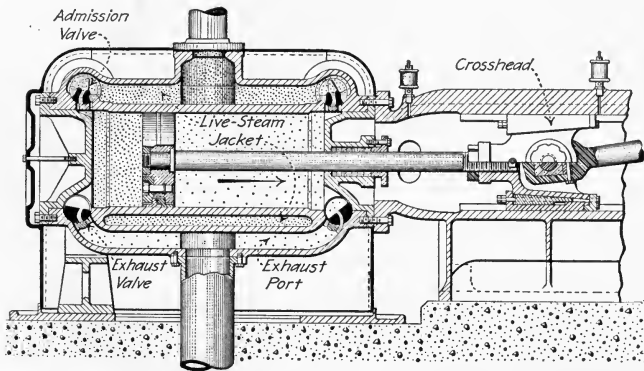

FIG. 359.—Jacketed steam-engine cylinder. (Rice and Sargent Corliss engine, Providence Engineering Corporation.)

ratio is, at full load, about 8:1 for simple engines and about 20:1 for compound engines.

NOTE.—THE PRACTICAL LIMITS OF BOILER PRESSURE IN STATIONARY POWER PLANTS are about 125 lb. per sq. in. for simple engines, 200 lb. per sq. in. for compound and uniflow engines and 250 lb. per sq. in. for triple-expansion engines (see also Sec. 428). These limits are fixed by the engine—not by the boiler. Boilers for turbine service are being

operated at 350 lb. per sq. in. The limits are fixed by the ability of engines of the different types to use large pressure ranges without excessive cylinder condensation (see Sec. 274). There is little advantage in an increased boiler pressure unless the engine can expand the high-pressure steam satisfactorily to nearly the exhaust pressure.

NOTE.—OTHER POSSIBLE METHODS OF DECREASING REJECTION LOSSES are: (1) *Steam jacketing* the cylinders and receivers, and (2) *using other working substances* besides steam. (3) *Decreasing valve and piston leakage*. Steam jackets (Fig. 359) are often employed as an operating convenience to improve the quality of the exhaust steam. The total losses, because of the heat used in the jacket, are often greater with than without the jacket. The utilization of other fluids in the same way steam is used is not commercially employed at present. Some experiments in which the exhaust has been condensed by a more volatile liquid which was thereby volatilized have proved successful in decreasing the rejection losses. Valve and piston leakage in steam engines often causes rejection losses of 10 to 20 per cent. even though the operation of the engines is apparently normal.

305. Clearance Volume Affects The Output And Economy Of An Engine.—It is necessary

for good operation of high-speed engines to compress the steam in the clearance volume almost to the throttle pressure. In low-speed engines, the most economical compression may be one-third or less of the throttle pressure. Due to the area under the compression line—that is, the work done in compressing the steam—the output and efficiency of an engine will ordinarily be less with larger clearance volume.

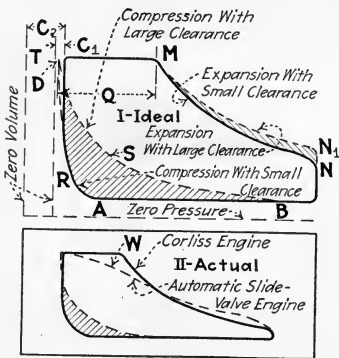

FIG. 360.—Showing how less power is derived from the same amount of steam when the clearance volume is larger.

EXPLANATION.—Fig. 360-I shows two superimposed ideal indicator diagrams having expansion lines, MN and MN_1 . The solid-line diagram has a clearance volume, C_1 , of 3 per cent. Compression occurs at A and the cushion steam is compressed along line R , to about one-half throttle pressure. The dashed-line diagram has a clearance volume, C_2 , of 15 per cent. Compression then occurs at B and the cushion steam is compressed along line S . The shaded area between lines, R and S , then represents the loss in work due to the larger clearance volume, C_2 .

The steam is compressed to the same theoretical point, D , on the throttle pressure line so that the amount of steam used, Q , is the same in both diagrams. With the larger clearance, there is a slight gain in work on the expansion line represented by the shaded area, MNN_1 . This area would be equal to the area RS , if the expansion were carried out to back pressure but, with incomplete expansion, area MNN_1 is smaller than area RS . Fig. 360-II shows the difference between the clearance losses in actual Corliss and automatic-engine diagrams. The wire-drawing at W in the automatic-engine diagram nullifies the theoretical gain due to larger clearance shown at N_1 in I.

306. Table Showing Typical Values For Clearance In Engines Of Different Types, based partly on data from Marks' MECHANICAL ENGINEERS' HANDBOOK:

Engine	Clearance as a percentage of the displacement volume	
	High value	Low value
Flat slide valve at side of cylinder.....	10	5
Piston valve at side of cylinder.....	15	7
Corliss valves.....	8	2
Poppet valves.....	4	1.5

307. Cylinder Condensation Is The Cause Of Part Of The Rejection And Thermal Losses in a steam engine. The three causes of cylinder condensation are: (1) The natural mixing of the supplied steam with the colder steam in the clearance space. This can be greatly reduced by using high compression pressures. (2) Alternate exposure of the cylinder walls to the live steam and exhaust steam. Condensation due to this cause is partly avoided by compounding and use of the uniflow principle. (3) Radiation of heat through the cylinder walls. This is considered a thermal loss (Sec. 309).

NOTE.—JACKETING (Fig. 359) PREVENTS SUCH CONDENSATION IN THE CYLINDER PROPER AS IS DUE TO RADIATION. However, condensation takes place in the jacket, and often exceeds, in amount, the saving due to no condensation in the cylinder proper. Jackets are useful in keeping cylinders warm or warming them up in starting.

308. Where The Exhaust Steam Can Be Economically Used For Heating, the rejection losses are of little consequence.

Many power plants which furnish both power and heat use large, simple slide-valve engines and make few provisions for reducing rejection losses. The power plant may then be 50 to 80 per cent. efficient because the exhaust steam is used for heating. The plant then has no rejection losses—only mechanical and thermal losses. The performance of the engine itself is no better under these conditions than if the rejected heat were lost but the expense of the rejected heat cannot, when the exhaust is used, be charged to the engine as it can when the live steam is used, for power only.

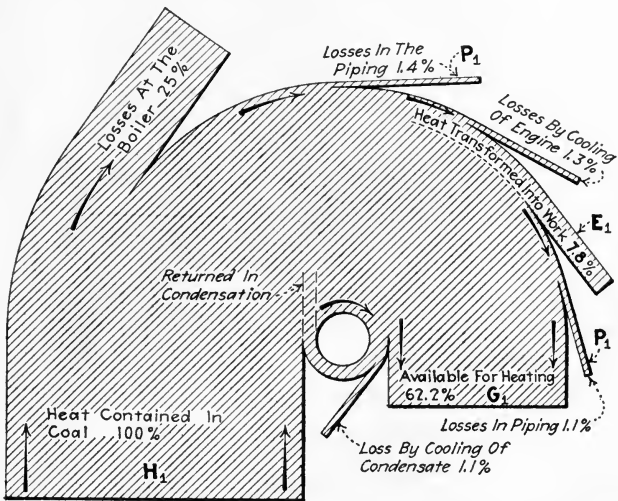

FIG. 361.—Showing heat balance in a power plant in which the engine exhaust is used for heating.

EXPLANATION.—The advantage of using an engine's exhaust steam for heating where both power and heat are desired may be understood by comparing Fig. 361 with Fig. 362. In Fig. 361, it is shown that, with the exception of boiler losses and small piping losses, P_1 , nearly all of the heat, H_1 , imparted to the steam in the boiler appears either as work or as useful heat. In Fig. 362, part of the steam, G_2 , is used directly for heating and the rest, E_2 , for operating a condensing engine. There is then a large heat loss in the condenser. Less power is developed by the Fig. 362 arrangement and less heat is available from the same original supply than is available with the arrangement shown in Fig. 361. Thus it is evident that although the efficiency of an engine may be low, the efficiency

of the combined power and heating plant in which the engine is used may be very high.

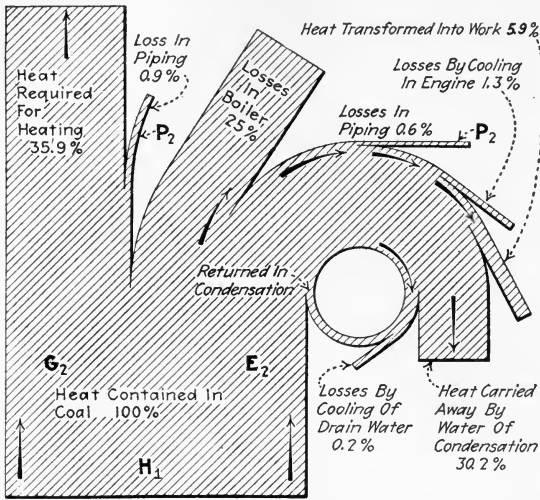

FIG. 362.—Heat balance in a plant operating a condensing engine and using live steam for heating.

309. The Principal Method Of Reducing Thermal Losses is by employing *heat insulation* or *lagging* on the cylinder

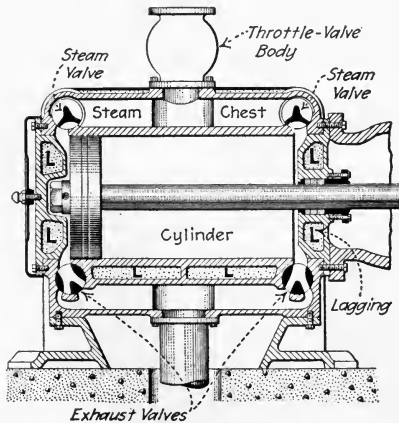

FIG. 363.—Well heat-insulated engine cylinder. (Cooper Corliss engine.)

walls. The heat conductivity of the metal parts of an engine cylinder is fairly high and, therefore, if they are exposed to

the steam on one side and the air on the other, they conduct much heat from the steam to the air. A layer of porous non-metallic material such as magnesite, asbestos, or diatomaceous earth (*L*, Fig. 363) is packed around the cylinder walls to reduce radiation. The transmission of steam from one point to another always involves a thermal loss. The fact that transmitting any form of energy involves a loss is illustrated by the losses in the electric circuits of Fig. 364.

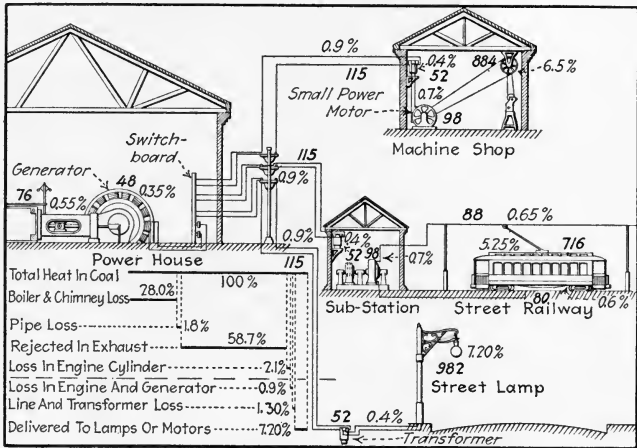

FIG. 364.—Showing energy balance (losses and useful energy) in typical electric-energy distribution circuits based on a chart from *Power*. (The heavy figures represent energy lost or used in British thermal units per pound of coal fed to the furnace based on a coal which has a heating value of 13,543 B.t.u. per pound. The lighter figures indicate percentages of the total heat. The calculations were made on the basis that the generator is supplying power to only one of the three circuits—either the machine shop, the street railway, or the street lamps. Should more than one circuit be in use at any time, the energy available for these circuits would still total 9.4 per cent., as shown below the dashed dividing line in the list, but it would be divided among the circuits in use. The diagram does not show the losses which are listed above the dashed dividing line of the list.)

310. The Two Principal Methods Of Reducing Mechanical Losses In An Engine are: (1) *Designing* the engine so as to minimize pressures on bearing surfaces. (2) *Proper lubrication* (see Div. 16). Large bearings using thick oil have more friction than do smaller bearings using thinner oil. But, for satisfactory operation, the bearing area and viscosity of the oil must be such that an oil film will always be main-

tained between the rubbing surfaces. A vertical engine has slightly less friction than a similar horizontal one. Because of their vertical position, the rapidly moving parts—that is, the piston and crosshead—have little tendency to press against the cylinder and guides. An engine running “under” (Sec. 32) has less friction on the guides than one running “over” because when running under the thrust of the connecting rod partially supports the crosshead. Stationary engines are commonly built horizontally (Sec. 25) (because of the simpler balancing and framework) and run “over,” in spite

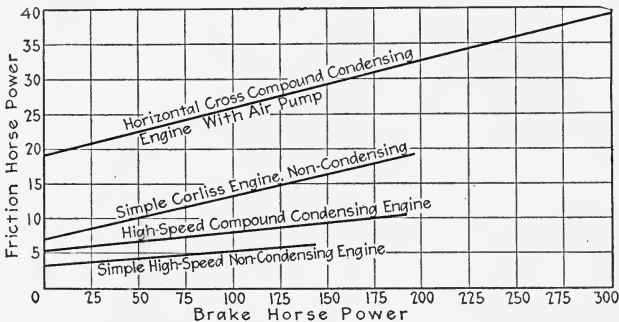

FIG. 365.—Showing variation in friction horse power with variation in brake horse power developed.

of the differences in friction, as a rule (because of the easier maintenance); see Div. 13. The frictional losses of all engines increase somewhat with the power which the engine develops as indicated in Fig. 365 which is taken from Gebhardt's STEAM POWER PLANT ENGINEERING.

311. Engine Friction Comprises Principally: (1) *Bearing friction.* (2) *Valve friction.* (3) *Gland friction.* Bearing friction is reduced to a minimum by the use of low-friction combinations of metals. Thus, hard steel running in babbitt metal for main bearings (Fig. 366) and hard steel on bronze bushings for connecting-rod bearings (Fig. 367) are widely used. Piston friction may be reduced by means of low-friction metal inserts (Fig. 368) in the wearing face of the piston. Friction in slide and poppet-valves is reduced by balancing the valves (see Divs. 4 and 5). Gland friction may be re-

duced by using metallic-faced packing (Fig. 369) and other low-friction packings—being careful never to have the packing pressed too tightly against its rod.

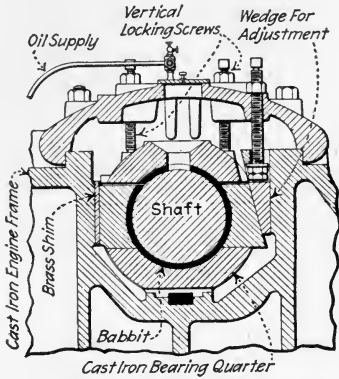

FIG. 366.—Showing low-friction—babbitt—metal inserted in main bearing. (Erie Ball Engine Co.)

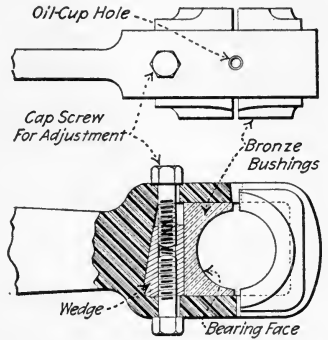

FIG. 367.—Bronze-bushed connecting-rod bearing. Closed-end type.

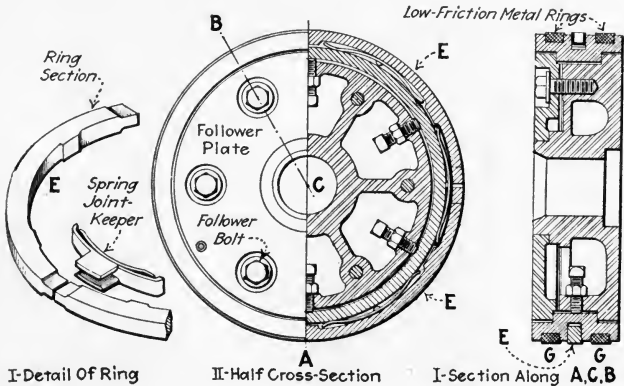

FIG. 368.—Piston designed to reduce friction and wear by means of low-friction bull-rings, GG. (The single expansive ring E is used to make a tight contact with the cylinder walls.)

312. Mathematical Methods Of Computing Steam-Engine Efficiencies will be discussed in the remainder of this division. The preceding sections considered, in a general way, the causes of steam-engine losses and the common methods of minimizing them. To calculate the exact effect of changes

in operating conditions which were previously mentioned, the mathematical methods which herein follow may be employed. Before proceeding consult the portions of Div. 1 which discuss the relations between heat and work and energy and also those portions of Div. 12 which relate to efficiency.

313. Various Ways In Which The Efficiency Of A Steam Engine Is Commonly Expressed are as follows: (1) Based on *indicated horse power*, it may be expressed as: (a) *Thermal efficiency based on indicated horse power*, E_{dti} in Fig. 370. (b) *Pounds of steam used per indicated horse power hour*. (c) *Pounds of coal burned per indicated horse power hour*. (d) *British thermal units per indicated horse power minute*. (e) *Thermal efficiency based on indicated horse power compared to the ideal Rankine cycle*, also called *cylinder efficiency*.

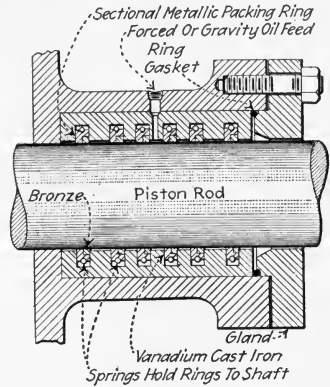

FIG. 369.—Piston-rod gland packing having low-friction metal wearing face. (Erie City Iron Works.)

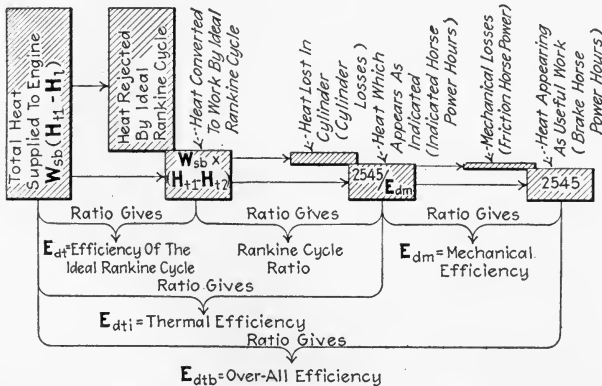

FIG. 370.—Chart showing relation between the various engine efficiency standards.

(2) Based on *brake horse power*, it may be expressed as: (a) *Over-all thermal efficiency or efficiency based on brake horse power*, E_{dab} in Fig. 370. (b) *Pounds of steam per*

brake horse power hour. (c) Pounds of coal per brake horse hour. (d) British thermal units per brake horse power hour. (e) British thermal units per kilowatt hour. (f) Pounds of coal per kilowatt hour.

(3) Mechanical efficiency, E_{dm} in Fig. 370.

NOTE.—THE STEAM CONSUMPTION is ordinarily calculated for the engine on a dry-steam basis. Engine manufacturer's performance specifications are practically always computed on this basis. The weight of dry steam is the weight of the wet steam multiplied by its quality, expressed decimally. A little water suspended in the steam does not decrease the engine efficiency when the efficiency is computed on a dry-steam basis (See the A.S.M.E. TEST CODE in Sec. 381). But the water, of course, does no work. Hence, when an accurate determination is being made, the presence of the water must be considered and the apparent efficiency decreased accordingly. In any case, the efficiency is proportional to the quality of the steam.

NOTE.—THE "THEORETICAL EFFICIENCY" DEFINED IN DIV. 1 is very nearly equal to the *thermal efficiency* as shown in Fig. 370. The "theoretical efficiency" in Div. 1 includes a small amount of losses by radiation from the engine whereas the thermal efficiency includes only the net indicated work. The "theoretical efficiency" is not ordinarily computed in power plant testing.

314. The Ideal Rankine Cycle Is Frequently Used In Steam-Engine Testing As A Standard Of Engine Performance. (See note below and also the author's PRACTICAL HEAT.) The ideal Rankine cycle (Sec. 8; also called the *Clausius cycle*) is the most nearly perfect cycle upon which a commercial steam engine can operate. It is, therefore, the logical cycle with which to compare steam-engine performance. A mechanically perfect engine without friction, without clearance losses, with perfectly non-conducting cylinder walls, and which expanded the steam from exactly throttle pressure to exactly back pressure, would develop all of the power of the ideal cycle (see Fig. 7). Since no actual engine can have all of these characteristics, no engine can have as great an efficiency as the ideal Rankine cycle on which it operates.

NOTE.—A RANKINE CYCLE MAY HAVE CLEARANCE AND STILL BE IDEAL. That is, clearance does not involve a loss, provided compression is so timed that the steam in the clearance space is compressed to throttle

pressure. Thus I and II (Fig. 371) show ideal performance but III, having terminal drop, T , is less efficient.

NOTE.—AN ENGINE CYCLE is understood to mean the series of repeating processes which occur in the engine cylinder. The cycle is conveniently pictured on the indicator diagram, which is thus a cycle diagram. Thus, in a practical steam engine the cycle diagram is composed of (as shown in Fig. 88) an admission line, a steam line, an expansion line, a release line, an exhaust line, and a compression line. Moreover, the exact cycle of any particular steam engine is further determined by the pressure variations along each of these lines.

315. To Compute The Efficiency Of The Ideal Rankine Cycle for any set of operating conditions, use the following formula:

$$(29) E_{dt} = \frac{H_{t1} - H_{t2}}{H_{t1} - H_{l2}} \text{ (a decimal)}$$

Wherein: E_{dt} = the thermal efficiency of the ideal Rankine cycle, expressed decimally. H_{t1} = the total heat per pound of steam as admitted to the engine. H_{t2} = the total heat per pound of steam as exhausted from the engine, assuming that it expands adiabatically from the conditions of H_{t1} . H_{l2} = the heat of liquid at the temperature and pressure at which the steam is exhausted.

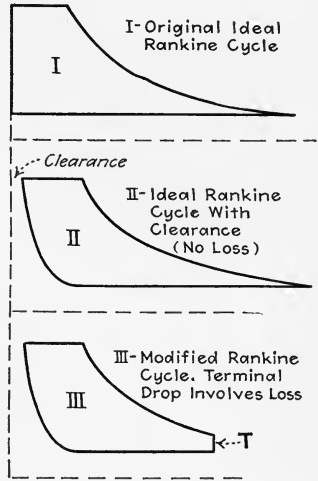

FIG. 371.—Showing two forms of the ideal Rankine cycle and modified Rankine cycle.

DERIVATION.—In general, *thermal efficiency = heat converted into work ÷ heat input*. The heat converted into work in the ideal Rankine cycle, since there is no thermal loss, is the difference between the heat present in the steam admitted and that present in the steam exhausted—or $H_{t1} - H_{t2}$. The heat input is the amount of heat which must be supplied to the water at the exhaust temperature to convert it to steam at the admission temperature and pressure, namely $(H_{t1} - H_{l2})$. Hence the *efficiency = heat converted into work ÷ the heat input = $(H_{t1} - H_{t2}) ÷ (H_{t1} - H_{l2})$* .

EXAMPLES.—Compare the efficiencies of ideal Rankine cycles under the following conditions: (1) 95 per cent. quality steam at 100 lb. per

sq. in. abs. and 20 lb. per sq. in. abs. back pressure. (2) Saturated steam at 175 lb. per sq. in. abs. to 1 lb. per sq. in. back pressure. (3) Superheated steam at 175 lb. per sq. in. abs. and 200 deg. Fahr. superheat to 1 lb. per sq. in. abs. back pressure.

SOLUTIONS.—Find the total heats from a total-heat-entropy chart or temperature-entropy chart such as that found in the author's PRACTICAL HEAT and find the heats of liquids from the steam table. By For. (29), the thermal efficiency, $E_{dt} = (H_{t1} - H_{t2}) / (H_{t1} - H_{t2})$ or:

For condition (1), $E_{dt} = (1138 - 1025) \div (1138 - 196) = 0.120 = 12.0 \text{ per cent.}$

For condition (2), $E_{dt} = (1197 - 869) \div (1197 - 70) = 0.291 = 29.1 \text{ per cent.}$

For condition (3), $E_{dt} = (1307 - 937) \div (1307 - 70) = 0.299 = 29.9 \text{ per cent.}$

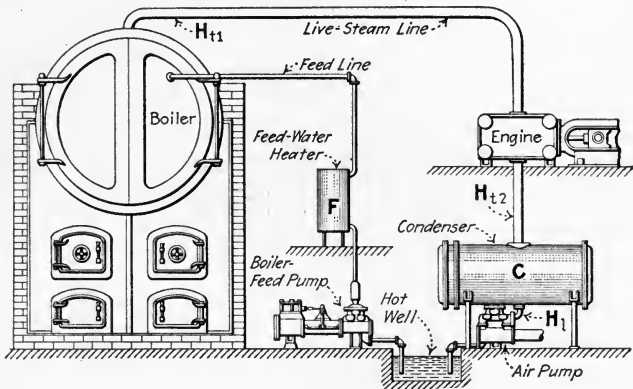

FIG. 372.—Showing steam and feed-water cycle in power plant.

NOTE.—WHY THE HEAT OF THE LIQUID AT THE TEMPERATURE OF THE EXHAUST IS TAKEN AS A BASIS IN CALCULATING EFFICIENCY may be understood by referring to Fig. 372. The exhaust steam is, or may be, condensed and returned to the boiler as feed water. The heat which must be imparted to the water to convert it into steam at the condition at which it is to enter the engine is thus added by the boiler to that already contained in the feed water. Actually the feed may be returned at a higher or a lower temperature than that of the engine exhaust because of the losses in the condenser, *C*, and gains in the heater, *F*; but such temperature differences are considered to be due to the other power plant equipment and not to the engine itself. If the exhaust steam were merely condensed in *C*—not further cooled after condensation—then the condensate would have the same temperature as has the exhaust steam; that is, its heat content would be H_{t2} .

316. To Compute The Theoretical Water Rate Based On The Ideal Rankine Cycle (also called the *Rankine water rate*) use the following formula:

$$(30) \quad \mathbf{W}_s = \frac{2545}{H_{11} - H_{12}} \quad (\text{lb. per h.p. hr.})$$

Wherein: \mathbf{W}_s = weight of steam, in pounds, used per horse power hour, or the *water rate*. H_{11} = the total heat of steam per pound as admitted to the engine. H_{12} = the total heat per pound of steam as exhausted from the engine, assuming that it expanded adiabatically from the conditions of H_{11} .

DERIVATION.—There are 778 ft. lb. in 1 B.t.u.; also there are 33,000 \times 60 ft. lb. in 1 h.p. hr. Therefore, there are 33,000 \times 60 \div 778 = 2545 B.t.u. in 1 h.p. hr. output. But from each pound of steam there are abstracted by the expansion ($H_{11} - H_{12}$) B.t.u. That is, the heat input converted into work is the difference between the heat contents of the admitted and the exhausted steam. Therefore, *the number of pounds of steam required for each horse power hour* = 2,545 \div ($H_{11} - H_{12}$).

EXAMPLE.—What is the theoretical water rate of an engine operating on 98 per cent. quality steam at 165 lb. per sq. in. abs. and exhausting at 212 deg. fahr. SOLUTION.—By the temperature-entropy chart, the total heats are, respectively, 1175 and 1005 B.t.u. By For. (30), the water rate, $\mathbf{W}_s = 2545 / (H_{11} - H_{12}) = 2545 \div (1175 - 1005) = 15.0$ lb. per h.p. hr.

317. To Compute The "Thermal Efficiency Of An Engine Based On Indicated Horse Power," use the following formula:

$$(31) \quad \mathbf{E}_{dti} = \frac{2545}{\mathbf{W}_{si}(H_{11} - H_{12})} \quad (\text{a decimal})$$

Wherein: \mathbf{E}_{dti} = the thermal efficiency of an engine, expressed decimally, based on indicated horse power. \mathbf{W}_{si} = the actual weight of steam consumed, in pounds per indicated horse power per hour as shown by test (Div. 12). H_{11} = the total heat per pound of the steam as admitted to the engine. H_{12} = the heat of liquid as found in a steam table, at the temperature of the engine exhaust.

DERIVATION.—Always the *efficiency = the output \div the input*. The heat equivalent of one indicated horse power hour output of work is 2545 B.t.u. The heat "input" consumed by the engine in producing this 2545 B.t.u. of work output is the weight of steam used (\mathbf{W}_{si}) multiplied by the heat brought from the boiler by each pound ($H_{11} - H_{12}$) or: $\mathbf{W}_{si}(H_{11} - H_{12})$. Hence the efficiency, $\mathbf{E}_{dti} = \text{output} \div \text{input} = 2545 \div \mathbf{W}_{si}(H_{11} - H_{12})$.

NOTE.—Now when the steam admitted is dry and saturated, its total heat may be found in a saturated steam table; when superheated, it may be found in a superheated steam table. Its heat for any condition may be found on a total-heat-entropy chart or a temperature-entropy chart. Also, when wet (as is usually the case) the total heat may be calculated by the following formula:

$$(32) \quad H_{t1} = x_d H_v + H_l \quad (\text{B.t.u. per lb.})$$

Wherein: x_d = the quality of the steam, expressed decimally. H_v = the latent heat per pound of steam. H_l = the heat per pound of liquid at the steam temperature. Also the total heat of steam when superheated may be calculated from the following formula:

$$(33) \quad H_{t1} = H_d + T_n C_m \quad (\text{B.t.u. per lb.})$$

Wherein: H_d = the total heat per pound of dry saturated steam at the same pressure. C_m = the mean specific heat of the superheated steam as taken from a mean specific heat chart such as that found in the author's PRACTICAL HEAT. T_n = the number of degrees Fahrenheit of superheat.

EXAMPLE.—What is the thermal efficiency of an engine which uses 30 lb. of 95 per cent. quality steam at 100 lb. per sq. in. abs. The temperature of the exhaust is 228 deg. Fahr. SOLUTION.—The total heat of the wet steam, $H_{t1} = x_d H_v + H_l = 0.95 \times 888 + 298 = 1142$ B.t.u. The thermal efficiency, $E_{th} = 2545/W_{si}(H_{t1} - H_{t2}) = 2545 \div 30 \times (1142 - 196) = 0.090 = 9.0$ per cent.

318. The Water Rate Of A Steam Engine Is Usually Taken As A Measure Of Its Economy.—Although, as shown by For. (30), the water rate is not really a measure of its efficiency—the efficiency of an engine depending also on the state of the steam supplied to it and the pressure at which it exhausts—the water rate is more useful than the efficiency when the economy of the entire plant is considered in conjunction with the performance of the engine. This may be a fallacy arising from the manner in which plant operation is usually computed; but, since no better method of calculation has yet been devised, and since the water rate method is comparatively simple, this method will be followed in later divisions. The simplicity of the water rate method of computing plant economy arises from the facts that: (1) *The water rate of an engine, when operating under certain steam pressures and temperatures, is independent of what further use is made of the steam after it leaves the engine.* (2) *The water rate of an engine usually determines, very nearly, the*

amount of steam which must be generated in the boiler and, therefore, the size of the boiler. (3) The water rate is more directly measureable from the readings of instruments (see Div. 12). The efficiency is usually determined from the same readings but involves further calculation. (4) The water rate, when considered in combination with the steam pressures and temperatures, gives an experienced engineer a good idea of the engine's efficiency. However, one must not lose sight of the fact that the water rate alone does not give a complete indication of efficiency.

EXAMPLE.—Assume that engine No. 1 uses 25 and engine No. 2, 23 lb. of steam per indicated horse power hour. Engine No. 1 operates on saturated steam at 100 lb. per sq. in. abs. and exhausts against 5 lb. per sq. in. gage back pressure. Engine No. 2 operates on saturated steam at 190 lb. per sq. in. abs. and exhausts condensing at 2 lb. per sq. in. abs. Compare their thermal efficiencies. SOLUTION.—By For. (30) the thermal efficiency, $E_{th} = 2545/W_{si}(H_{i1} - H_{i2}) = 2545 \div 25(1186 - 196) = 10.3$ per cent. for engine No. 1. $E_{th} = 2545 \div 23(1197 - 94) = 10.0$ per cent. for engine No. 2. Therefore engine No. 2, although it uses less steam, has a lower thermal efficiency than engine No. 1.

319. The Efficiency Of An Engine Compared To The Ideal Rankine Cycle (often called the *Rankine cycle ratio* or *cylinder efficiency*) is the ratio of its actual thermal efficiency to the efficiency of the ideal Rankine cycle for the same operating conditions. Or, as a formula:

(34) *Rankine cycle ratio* = *Actual thermal efficiency* \div *Rankine cycle efficiency*.

EXAMPLE.—The efficiency of the ideal Rankine cycle under conditions (1) Sec. 315, is 12 per cent. The actual thermal efficiency under the same conditions (Sec. 317) was 9 per cent. The Rankine cycle ratio is then $9.0 \div 12.0 = 0.75$.

320. A Table Showing Typical Values Of The Rankine Cycle Ratios For Engines Of Different Types (from Marks' MECHANICAL ENGINEERS' HANDBOOK):

Type of engine	Condensing	Non-condensing
Simple.....	0.4	0.6
Compound.....	0.5	0.65
Triple-expansion.....	0.6	

321. The Mechanical Efficiency Of An Engine is the ratio of its brake horse power to its indicated horse power. The two horse powers are understood to be measured simultaneously (see Div. 12).

$$(35) \quad E_{dm} = \frac{P_{bhp}}{P_{ihp}} \quad (\text{a decimal})$$

Wherein: E_{dm} = the mechanical efficiency of the engine, expressed decimally. P_{bhp} = the brake horse power. P_{ihp} = the indicated horse power developed at the same time during which P_{bhp} was delivered. For other relations between indicated and brake horse powers, see Sec. 127.

EXAMPLE.—An engine delivers 227 brake horse power while the indicated horse power is 235. What is the mechanical efficiency? SOLUTION.—By For. (35), the mechanical efficiency, $E_{dm} = P_{bhp}/P_{ihp} = 227 \div 235 = 0.966 = 96.6 \text{ per cent.}$

322. The Over-All Efficiency Or “Thermal Efficiency Based On Brake Horse Power” is computed in the same way as that based on indicated horse power except that the water rate per brake horse power is used. Thus, For. (30) becomes:

$$(36) \quad E_{dtb} = \frac{2545}{W_{sb}(H_{t1} - H_{t2})} \quad (\text{a decimal})$$

Wherein: E_{dtb} = the thermal efficiency, decimally expressed, based on brake horse power. W_{sb} = weight of steam consumed per brake horse power hour. H_{t1} = the total heat per pound of steam as admitted to the engine. H_{t2} = the heat of liquid per pound at the temperature of the exhaust.

EXAMPLE.—An engine uses 16 lb. of steam per brake horse power hour. If the total heat of steam as admitted to the engine is 1190 B.t.u. per lb., and the heat of liquid at exhaust temperature is 90 B.t.u. per lb. what is the over-all efficiency of the engine? SOLUTION.—By For. (36), the over-all efficiency, $E_{dtb} = 2545/W_{sb}(H_{t1} - H_{t2}) = 2545 \div 16(1190 - 90) = 0.145 = 14.5 \text{ per cent.}$

323. The Other Measures Of Engine Efficiency given in Sec. 313 are found by test or may be computed as follows: The British thermal units per brake or indicated horse power hour may be computed by multiplying the number of pounds of

steam used per horse power per hour by the total heat of steam as admitted minus the heat of liquid of the exhausted steam. Kilowatt hour values may be found by applying the relation $1 \text{ h.p.} = 0.746 \text{ kw.}$ Thus:

$$(37) \quad B.t.u. \text{ per } i.h.p. \text{ hr.} = \mathbf{W}_{si}(H_{l1} - H_{l2})$$

$$(38) \quad B.t.u. \text{ per } b.h.p. \text{ hr.} = \mathbf{W}_{sb}(H_{l1} - H_{l2})$$

$$(39) \quad B.t.u. \text{ per } i.h.p. \text{ min.} = \mathbf{W}_{si}(H_{l2} - H_{l2})/60$$

$$(40) \quad B.t.u. \text{ per } b.h.p. \text{ min.} = \mathbf{W}_{sb}(H_{l1} - H_{l2})/60$$

See the author's STEAM TURBINE PRINCIPLES AND PRACTICE for discussion of the reasons for expressing the performance of the steam engines and turbines in so many different ways, and for an explanation of the significance of and relationship between the *Rankine-cycle efficiency*, *Rankine-cycle ratio*, and *thermal efficiency*.

NOTE.—THE FOLLOWING TABLES SHOW EFFICIENCIES AND PERFORMANCE OF STEAM ENGINES UNDER VARIOUS OPERATING CONDITIONS. These tables are taken from Gebhardt's STEAM POWER PLANT ENGINEERING published by John Wiley and Sons, New York.

324. Table Showing Economy Of Simple Counterflow Engines, Operating On Saturated Steam.

Kind of engine	References	Cylinder dimensions, inches	Indicated horse power	Initial pressure, lb. gauge	Back pressure, lb. per sq. in. abs.	M.E.P.	R.P.M.	Lb. dry steam per i.h.p. hr.	B.t.u. per l.h.p. per min.	Thermal efficiency, per cent.	Rankine cycle ratio, per cent.	Mechanical efficiency, per cent.
Willans.....	Peabody, Thermodynamics.....	14 X 6	33.6	122.0	Atmos.	400	26.0	439	9.7	60.0
Willans.....	Peabody, Thermodynamics.....	14 X 6	16.5	36.3	Atmos.	393	42.8	709	6.0	65.5
Locomotive Purdue.....	Trans. A.S. M.E., Vol. 14, p. 826	17 X 14	399.0	110.0	Atmos.	54.0	136	24.97	421	10.1	65.7
Westinghouse standard.....	Shop test.....	20 X 16	257.0	100.0	Atmos.	36.0	275	26.19	440	9.6	65.2
Buffalo forge.....	Elec. World, Sept. 1, 1904, p. 407.	12 X 12	121.0	124.0	Atmos.	58.5	302	27.5	464	9.2	57.5
Reeves.....	Elec. World, Oct. 1, 1904, p. 587.	15 X 14	120.0	114.0	Atmos.	35.0	275	28.0	472	9.0	55.4	92.5
Ames.....	Eng. Record, July 6, 1901, p. 7...	13 X 12	105.0	95.0	Atmos.	52.0	250	29.1	489	8.7	60.0
Ames.....	Meyer, Steam Power Plants, p. 56	17 X 16	248.0	100.0	Atmos.	50.0	270	26.0	437	9.7	65.9
Locomotive, No. 1499, Penn. System.....	Locomotive Tests, 1904, at Louisiana Exposition.....	22 X 28	975.0	196.0	Atmos.	75.6	120	23.4	397	10.7	55.6	91.0
Buffalo forge.....	Elec. World, Sept., 1904, p. 407....	12 X 12	74.0	79.3	Atmos.	35.6	304	30.6	512	8.3	62.1	95.7
Single-valve, condensing												
Willans.....	Peabody, Thermodynamics.....	14 X 6	33.2	70.0	1.0	383.0	22.2	413	10.3	40.9
Reeves.....	Elec. World, Oct. 1, 1904, p. 587..	15 X 14	140.0	114.0	3.2	41.0	275.0	26.0	466	9.1	39.6	95.8
Buffalo Forge.....	Elec. World, Sept. 10, 1904 p. 407.....	12 X 12	86.0	80.0	3.0	40.5	310.0	27.5	494	8.5	40.4	95.0
Piston valve.....	Barrus, Engine Tests, p. 95.....	18½ X 30	204.6	69.3	2.6	38.1	29.3	27.15	485	8.7	40.9

Four-valve non-condensing

Corliss, jacketed.....	Peabody, Thermodynamics.....	21.6 × 43.3	237.0	103.5	Atmos.	42.1	62.7	21.5	361	11.7	79.5
Fleming.....	Prof. Carpenter, June 28, 1905, at Cornell University.....	19 × 19.0	217.0	120.5	Atmos.	39.0	205.9	22.46	378	11.2	70.4
Fleming.....	Prof. Spangler, June 6, 1905, at University of Pennsylvania.....	16 × 16.0	132.0	125.4	Atmos.	39.1	210.0	22.24	375	11.3	70.2	95.0
Fitchburg-Prosser.....	Prof. E. F. Miller, 1916.....	15 × 24	48.7	121.6	Atmos.	82.0	19.1	317	13.4	82.6
Ideal Corliss.....	Power, Mar. 4, 1913.....	16 × 22	240.0	150.0	Atmos.	59.0	200.0	20.7	350	12.1	70.2
Nordberg poppet valve.....	Shop test, 1916.....	15 × 18	123.0	130.0	Atmos.	38.0	200.0	18.8	318	13.4	80.0	90.8

Four-valve, condensing

Corliss, jacketed.....	Peabody, Thermodynamics.....	21.6 × 43.3	155.0	103.8	1.2	32.0	60.0	16.5	307	13.8	52.8
Poppet valves, jacketed.....	Zeit. d. V. D. Ing., Aug., 1905, p. 1310.....	22.6 × 45.0	262.0	79.0	1.36	30.2	47.6	15.0	276	15.4	62.8
Gridiron valves.....	Barrus, Engine Tests, p. 101.....	34½ × 60.0	613.0	82.3	1.0	37.2	60.0	18.5	344	12.3	46.0
Corliss.....	Barrus, Engine Tests, p. 118.....	32 × 60.0	554.0	67.5	2.9	38.2	59.1	19.45	348	12.1	58.8
Slide valves.....	Barrus, Engine Tests, p. 88.....	18 × 30.0	213.0	67.0	2.2	33.7	165.0	22.0	400	10.6	48.6
Corliss.....	Peabody, Thermodynamics.....	18 × 48.0	145.0	96.0	1.5	30.9	76.0	19.4	358	11.9	47.7

325. Table Showing Economies Of Multi-Expansion En-

Kind of engine	References	Cylinder dimensions
Quadruple		
Nordburg pumping engine, Wildwood, Pa.	Eng. News, May 4, 1899, p. 280	19½, 29, 49½, 57½ × 42
Triple		
Allis pumping engine, Chestnut Hill, Boston.	Eng. News, Aug. 23, 1909, p. 125	30, 56, 87 × 66
Allis pumping engine, Bissel's Point, St. Louis.....	Power, May, 1906, p. 299.....	34, 62, 94 × 72
Holly pumping engine, Spot Pond, Boston.	Eng. News, Nov. 14, 1901, p. 371.	22, 41, 62 × 60
Sulzer mill engine, Augsburg....	Zeit. d. V.D.I., May 16, 1896, p. 534.	29.9, 44.5, 2(51.6) × 78.7
Compound,		
Allis-Chalmers engines, New York Subway.....	Power, Feb., 1906, p. 115.....	2(42), 2(86) × 60
Cross-compound Corliss, Atlantic Mills, Providence.....	Am. Elec., June, 1903, p. 260.	16, 40 × 48
Leavitt puming engine, Louisville, Ky.	Trans. A.S.M.E., Vol. 16, p. 169.	27, 54 × 120
Rice & Sargent Corliss, Amer. Sugar Refinery, Brooklyn.	Trans. A.S.M.E., Vol. 24, p. 1274.	20, 40 × 42
Fleming four-valve.	Trans. A. S.M.E., Vol. 25, p. 212.	15, 40½ × 27
Williams Vertical, New York Navy Yard.....	Power, Oct., 1903, p. 583.....	19, 34 × 30
Tandem-compound Corliss.....	Barrus, Eng. Tests, p. 185.....	18, 44 × 72
Edison Waterside Sta., N. Y....	Power, July, 1904, p. 24.....	43½, 75.3 × 60
Compound,		
Ball & Wood Co. Corliss, W. Albany Sta., N. Y. C. & H. R. R.	Test by Company Engineers...	21, 41 × 30
Willans.....	Peabody, Thermodynamics....	10, 14 × 6
Willans.....	Peabody, Thermodynamics....	10, 14 × 6
Ball engines, Chicago Public Library.	Eng. Record, Aug. 6, 1898, p. 206.	12, 20 × 13
Westinghouse Marine.....	Power, Aug., 1903.....	17, 27 × 24
Skinner cross-compound.....	Power, July, 1906.....	16, 27 × 18
Buffalo tandem-compound.	Elec. World, May 23, 1903, p. 897.	12, 18 × 10
Reeves vert. cross-compound....	Eng. Record, July 1, 1905, p. 24	12, 20 × 14
Cross-comp'd, 4 slide valves....	Barrus, Eng. Tests, p. 181.....	17½, 28 × 48
4-cylinder compound locomotive No. 2512 Penna. System.	Tests made at Louisiana Exposition, 1904	14.2, 23.7 × 25.2

* Combined efficiency of pump and engine.

† Combined efficiency of engine and generator.

Engines Operating On Saturated Steam.

Cylinder ratio	Horse power	Initial press., lb. per sq. in. gauge	Back press., lb. per sq. in. abs.	R. P. M.	M. E. P. referred to L. P. cyl.	Temp. feed water, deg. Fahr.	Lb. of steam per i.h.p. hr.	B.t.u. per i.h.p. per min.	Thermal efficiency, per cent.	B.t.u. per i.h.p. min., perfect eng.	Rankine-cycle ratio, per cent.	Mech. efficiency, per cent.
expansion												
.....	712.0	200.0	0.9	36.5	35.5	310.8	12.26	186.0	22.8	138	74.2	93.0
expansion												
1:3½:8.4	801.0	185.0	0.85	17.2	23.4	155.0	10.33	196.0	21.63	138	70.5	*93.3
1:3.3:7.6	865.0	140.0	1.2	16.5	20.8	10.59	201.4	21.06	151	75.0	*97.4
1:3½:8	464.0	150.0	1.05	24.8	20.5	157.9	11.01	203.4	20.85	142	70.0	*96.5
1:2.2:5.9	1823.0	134.0	1.8	56.2	19.5	122.0	11.33	208.0	20.40	158	76.0
condensing												
1:4:2	7365.0	175.0	2.2	75.0	27.9	130.0	11.96	220.0	19.2	159	72.4	†93.0
1:6¼	500.0	170.0	0.8	80.0	20.5	11.20	222.0	19.0	141	63.5
1:4	643.0	137.0	0.95	18.6	24.9	100.0	12.20	222.0	19.0	150	67.6	93.0
1:4	627.0	151.0	0.85	121.0	19.4	121.0	12.10	222.7	19.0	143	64.3
1:7.3	348.0	150.0	2.0	152.0	13.0	126.0	12.33	225.8	18.7	162	71.7
1:3¼	340.0	100.0	2.0	150.0	16.5	126.0	12.60	229.0	18.5	175	76.5
1:6.4	6893.0	145.2	1.5	60.3	20.6	116.0	12.70	234.0	18.1	157	67.0
1:6.02	5442.0	185.0	1.5	76.3	26.5	116.0	11.93	221.0	19.2	150	68.0	†95.2
non-condensing												
1:3.8	1125.0	175.0	Atmos.	120.0	47.0	17.17	291.0	14.5	229	78.8
1:2.0	39.6	165.0	Atmos.	401.0	42.4	19.2	328.0	12.8	234	71.5
1:2.0	33.0	113.9	15.7	402.0	21.4	358.0	12.4	297	83.0
1:2.8	187.5	166.8	Atmos.	271.0	34.8	21.14	357.0	11.7	233	65.5	93.5
1:2¼	540.0	148.0	Atmos.	210.0	37.1	19.3	326.0	13.0	244	75.0	*87.5
1:2.84	375.0	130.0	Atmos.	226.0	31.0	21.14	355.0	11.9	255	72.0	91.5
1:2¼	121.0	128.0	Atmos.	271.0	35.0	22.3	376.0	11.2	258	68.5	93.0
1:2.77	185.0	150.0	Atmos.	56.0	20.9	354.0	11.9	242	68.5	92.0
1:2.58	486.7	125.3	Atmos.	99.0	32.9	21.59	362.0	11.7	266	71.9
1:2.78	495.0	210.0	Atmos.	80.0	55.0	18.6	316.0	13.4	216	68.5	91.0

Assumed for comparison, 212°F.

326. Table Showing Economy Of Engines Of Various Kinds

Kind of engine	References	Cylinder dimensions, inches
Triple		
Binary vapor eng., Royal High School, Berlin.	Jour. Franklin Inst., Dec., 1902, p. 456.
Sulzer, four-cylinder.....	Eng. News, Oct. 2, 1902, p. 259...	32, 47, 58 × 59
Sulzer, three-cylinder.....	Zeit. d. V. D. I., Aug., 1905, p. 1353.	15.5, 25.4, 37.5 × 25.6
Sulzer, three-cylinder.....	Engr., Lond., May 25, 1900, p. 546.	34, 46, 61 × 51
Worthington pumping eng., Central Park, Chicago.....	Eng. News, May 26, 1904, p. 287.
Riedler pumping engine, Chicago Ave. Sta., Chicago.	Engr. U. S., Nov. 15, 1907, p. 1092.	15, 29, 48 × 48
Compound		
Cole, Marchent and Morley, cross-comp., jacketed.	Engr., London, June, 1905, p. 546.	21, 36 × 36
Van den Kerchove, tandem, heads jacketed.	Amer. Elecn., May, 1903, p. 217.	12.8, 22 × 33.4
Van den Kerchove, tandem, Heads jacketed.	Amer. Elecn., May, 1903, p. 217..	12.8, 22 × 33.4
Easton & Co., tandem-compound.	Amer. Elecn., Apr., 1903, p. 178..	15, 24 × 48
Rice and Sargent, Melbourne Mills, Pa.	Trans. A.S.M.E., Vol. 25, p. 278.	16, 28 × 42
McIntosh and Seymour, Edison Co., So. Boston.	Trans. A.S.M.E., Vol. 25, p. 491.	29, 60 × 56
Cross-compound, cylinders jacketed.	Barrus, Eng. Test, p. 202.....	18, 48 × 48
Sulzer, tandem-compound.....	Eng. News, Oct. 2, 1902, p. 259..	26.8, 47.2 × 67
White, auto engine.....	Trans. A. S. M. E., Vol. 28.....	3, 6 × 4.5
Nordberg cross-compound.....	U. S. Metal Refining Co.....	19, 44 × 42
Simple		
Poppet-valve, condensing.....	Zeit. d. V. D. I., Aug., 1905, p. 1310.	16.3 × 39.4
Poppet-valve, condensing.....	Zeit. d. V. D. I., Aug., 1905, p. 1310.	16.3 × 39.4
Poppet-valve, non-condensing...	Zeit. d. V. D. I., Aug., 1905, p. 1310.	16.3 × 39.4
Ideal Corliss.....	Power, Mar. 4, 1913.....	16 × 22
Erie City Lentz.....	F. W. Dean, 1913.....	19 × 21

Using Superheated Steam.

Cylinder ratio	Horse power	Initial pressure, lb. per sq. in. gauge	Back pressure, in. abs.	R. P. M.	Lb. steam per i.h.p. hr.	B.t.u. per i.h.p. per min.	Thermal efficiency, per cent.	Rankine cycle ratio, per cent.	Superheat, deg. fahr.	Steam temp., deg. Fabr.
expansion										
.....	211	143.0	4.5	143.5	8.60	158.3	26.8	221.0	590
1:2.03:3.27	2860	173.0	2.0	85.0	8.97	187.7	22.6	73.5	230.0	606
1:2.64:5.9	549	166.0	2.4	144.4	10.00	207.3	20.4	68.5	229.0	602
1:2.08:3:22	2940	167.0	1.6	82.5	9.58	204.0	20.8	66.7	264.0	637
.....	646	146.8	1.6	18.6	10.00	196.0	21.6	72.5	87.0	451
.....	590.0	170.0	2.6	62.0	9.73	196.5	21.6	69.3	166.0	542
1:2.94	145.5	114.5	1.72	100.7	8.58	176.1	24.0	82.0	202.0	548
1:2.97	212	131.0	2.2	127.0	8.99	194.8	21.7	73.0	342.0	699
1:2.97	217.0	129.5	2.2	127.0	10.75	218.2	19.4	69.1	183.0	339
1:2.67	239.0	120.0	2.0	140.0	9.00	187.0	22.6	78.5	240.0	590
1:3.06	920.0	142.0	4.0	102.0	9.56	188.3	22.5	72.2	296.0	638
1:4.3	2202.0	158.0	4.8	98.0	11.21	209.0	20.2	79.8	92.0	462
1:7.3	659.0	143.0	3.4	80.0	11.89	223.5	19.0	73.5	40.0	402
1:3.1	788.0	116.0	2.8	65.0	9.68	207.2	20.3	71.5	343.0	690
1:4.0	40.0	426.0	Atmos.	85.0	11.96	244.0	17.4	68.0	316.0	766
1:5.4	620.0	155.0	3.87	100.0	11.01	212.0	20.0	75.3	76.1	444
.....	123.0	145.0	1.4	81.1	16.70	326.0	13.0	46.0	73.8	424
.....	20.0	145.0	1.5	81.2	14.70	307.4	13.8	47.6	226.2	576
.....	123.0	145.0	Atmos.	81.5	16.10	307.8	13.8	79.0	254.3	604
.....	190.0	125.0	Atmos.	200.0	18.3	328.0	13.0	78.5	107.0	459
.....	248.0	133.0	Atmos.	206.0	16.1	286.0	14.8	87.5	92.7	450

QUESTIONS ON DIVISION 10

1. Explain why only a small part of the total theoretical heat contained in steam may be utilized in a steam engine.
2. Explain why the greatest thermal efficiency does not always result in the lowest total power cost.
3. Is it usually possible to greatly increase the efficiency of an engine which is already in good repair? Why?
4. What class of losses in a steam engine tends to increase at over loads? What classes are proportionately larger at light loads?
5. Name several methods of decreasing percentage rejection losses.
6. What mainly determines the boiler pressure which is ordinarily used for steam engine service?
7. What are three principal causes of cylinder condensation?
8. Why may a steam-engine power plant be practically more efficient when both heat and power are desired than when the steam is generated for power purposes only?
9. What is the principal method of reducing thermal losses in a steam engine?
10. What method of reducing mechanical losses is applicable to an existing steam-engine installation?
11. What measures are taken to reduce gland friction? Bearing friction? Piston friction?
12. Explain by a diagram the relation between various standards of engine efficiency.
13. What effect on efficiency has a moderate amount of water in the steam admitted to a steam engine?
14. Why is engine performance compared to the ideal Rankine cycle? Name one modification of the original ideal Rankine cycle which is necessary in practice but which does not involve a loss. One which does.
15. Explain why the heat of liquid at the temperature of the engine exhaust is taken as a basis in engine-efficiency calculations.
16. What is the Rankine-cycle ratio of an engine? What other expressions are used to designate this same ratio?

PROBLEMS ON DIVISION 10

1. What is the efficiency of the ideal Rankine cycle operating on 99 per cent. quality steam at 200 lb. per sq. in. abs. and exhausting at 212 deg. fahr?
2. What is the theoretical water rate of an engine operating on steam at a total temperature of 550 deg. fahr. and a pressure of 150 lb. per sq. in. gage? The exhaust pressure is 1.5 lb. per sq. in. abs.
3. What is the thermal efficiency of an engine which uses 18.5 lb. of steam per indicated horse power hour and operates on 98 per cent. quality steam at 175 lb. per sq. in. abs., exhausting at atmospheric pressure?
4. If the engine in Problem 1 uses 25 lb. of steam per indicated horse power hour, what is its Rankine-cycle ratio?
5. What is the mechanical efficiency of an engine which delivers 175 brake horse power while showing 198 i.h.p.?
6. What is the over-all efficiency of an engine which uses 17.4 lb. of steam per b.h.p. hr.? The steam has 100 deg. fahr. superheat at 178 lb. per sq. in. abs. and is exhausted into a condenser which has 27 in. of mercury vacuum when the barometer reads 29.8 in.
7. How many British thermal units per brake horse power are used by the engine in Problem 6? How many British thermal units are used per kilowatt hour of mechanical power developed?
8. Compare the thermal efficiencies of two engines—one using 19 lb. of steam per indicated horse power hour at 125 lb. per sq. in. abs.; and the other 18 lb. at 225 lb. per sq. in. abs. Both exhaust at atmospheric pressure and use saturated steam.

DIVISION 11

STEAM ENGINES OF MODERN TYPES

327. The Material Here Given On "Steam Engines Of Modern Types" (see also Table 337) will outline the principal constructional, operating, and economic characteristics of the different types of modern engines. For each type there will, insofar as is feasible, be given information relating to the valves, their control, the speed in revolutions per minute, the type of governor, particular advantages, performance, and initial cost (Sec. 338). This information must, of necessity, be general because of the many engines in each class and their widely different characteristics. It is hoped that this information will provide a suitable basis for selecting the proper type and size of engine for a given service. The problems of selection, however, will be discussed in Div. 15.

328. Rotary Steam Engines (Fig. 373) differ from reciprocating engines in that the piston, or its equivalent, in the rotary engine rotates about the cylinder axis. The steam pressure forces the piston around, just as in the reciprocating engine the pressure forces the piston ahead. In this way the rotary engine differs from the steam turbine because in the turbine the momentum of the steam is imparted to the rotating member. Rotary engines when new and well made usually have steam rates of 60 to 125 lb. per i.h.p. hr. Since, due to their construction, it is difficult to take up wear in rotary engines, and since the chances for steam leakages are excessive, rotary engines, after they are used for a short time, consume a great amount of steam which simply passes through the engine without doing work. For this reason, although they possess many apparent advantages, rotary engines cannot compete with even the most wasteful reciprocating engines. Since they do not constitute a class of commercially useful steam engines, rotary engines will not, except as in the explanation below, be discussed further herein.

EXPLANATION.—The operation of the rotary steam engine is illustrated in Fig. 373. Assume that at the instant when steam is admitted, the piston, *AB*, stands as shown in *I*. The pressure of the steam acting on *A* exerts a force which is indicated by the small arrows. This force will rotate the rotor, *R*, to which *A* is secured. After position *II* is reached, piston *B* automatically closes the space behind *A* so that no more steam is admitted. However, steam is now admitted below *B*. The steam above *AB* still acts on piston *A* and tends to rotate *R*. This steam will expand slightly as *R* rotates from position *II* until *AB* is horizontal.

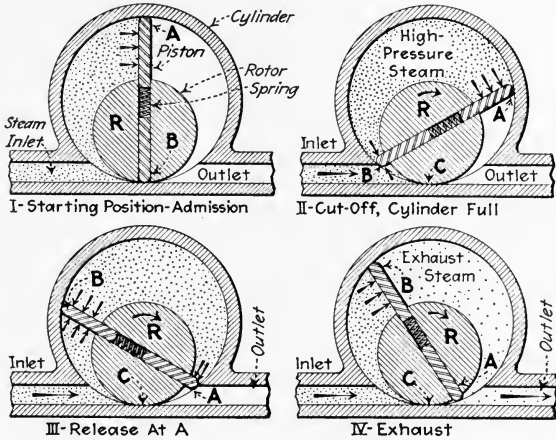

Fig. 373.—Illustrating principle of the rotary steam engine.

Then, however, the steam above *AB* is again compressed as *R* approaches position *III*. Here *A* is about to open the passage for the steam into the outlet. Position *IV* shows the steam exhausting from the cylinder. It is evident that in this engine work is done by the steam by virtue of direct pressure only—there is practically no expansion. It is obvious also that unless a tight joint is kept between the cylinder and rotor at *C*, positions *II*, *III*, and *IV*, steam can blow from the inlet to the outlet pipe without doing any work. The difficulty of keeping tight joints at *C* and at the ends of the pistons is the most objectionable feature of the rotary engine.

329. Simple Single-Valve Engines (Fig. 374) are made in a great number of styles in sizes from 2 to 900 h.p.; see Table 337. The speeds vary from about 600 to 150 r.p.m.; the piston speed, however, remains nearly the same for all engines—

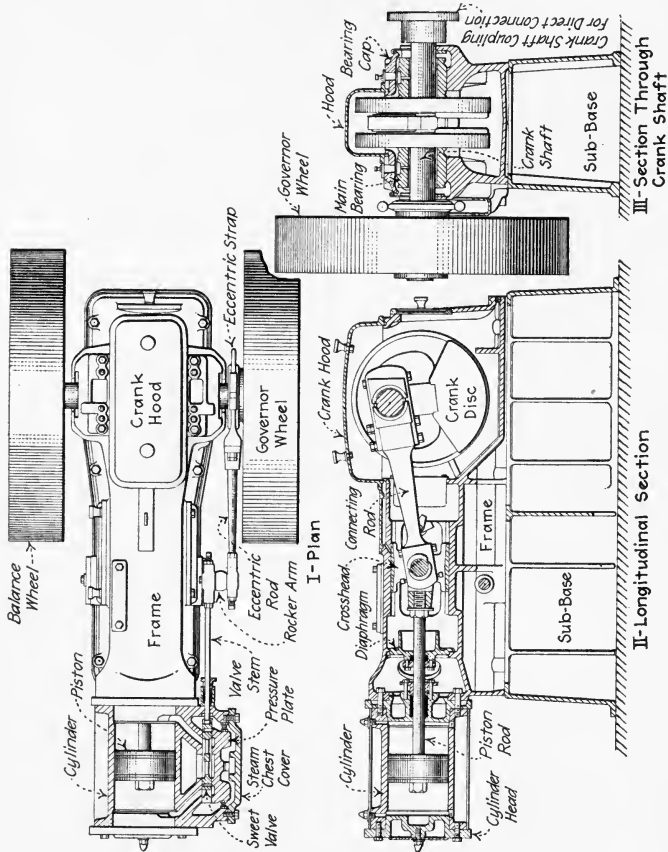

Fig. 374.—A typical high-speed, simple balanced-slide-valve engine. (Erie Ball Engine Co.)

about 600 feet per minute (f.p.m.) being an average value, although 800 f.p.m. is not uncommon. These engines are usually fitted with either piston (Fig. 375) or balanced slide valves except that, in the very small sizes, plain D-slide valves are sometimes used; see Table 337. Simple single-valve engines usually operate on steam at pressures below 125 lb.

per sq. in. gage, and no more than 50 deg. of superheat, although the piston-valve engines may safely be used with

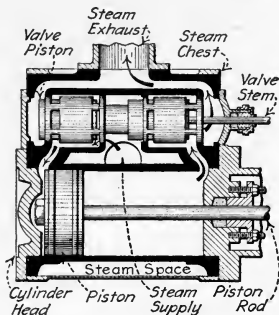

FIG. 375.—Section of cylinder of a piston-valve engine. (Arrows indicate direction of steam flow.)

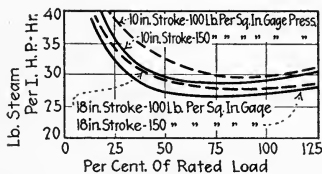

FIG. 376.—Typical steam consumption curves for good, simple high-speed engines non-condensing.

temperatures up to 570 deg. fahr. Simple single-valve engines may be obtained, usually, with either throttling or

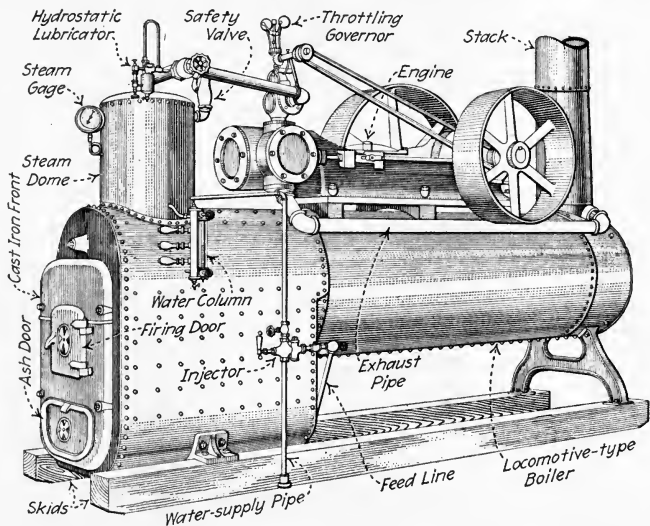

FIG. 377.—Typical small portable boiler and engine unit. (Ames Iron Works.)

shaft governors. They are seldom operated condensing; in fact, they are most widely used where fuel is very cheap or where large quantities of exhaust steam are needed for heating

or manufacturing purposes. They are compact, simple in construction and operation, and low in first cost. As is shown by Fig. 376, the steam consumption varies little at loads ranging from 50 to 125 per cent. of rated full load, but is much higher at small fractional loads. At full load, the steam consumption varies for different engines from 26 to 50 lb. per i.h.p. hr. depending on the cylinder size and initial steam pressure. A good average value may be taken as 30 lb. per i.h.p. hr. The most advisable cut-off when running non-condensing is about $\frac{1}{3}$ to $\frac{1}{4}$ stroke.

NOTE.—PORTABLE SLIDE-VALVE ENGINES are those which are intended for use: (1) Upon a portable boiler which may be mounted on skids (Fig. 377) or on wheels. (2) Upon only a temporary foundation which is usually made of timbers. A portable engine is usually furnished with a portable boiler—the two form a small portable power plant. Portable engine and boiler units are built in sizes up to about 75 h.p.

330. Compound Single-Valve Engines (Fig. 378) are generally used where, during a part of the year, their exhaust is to

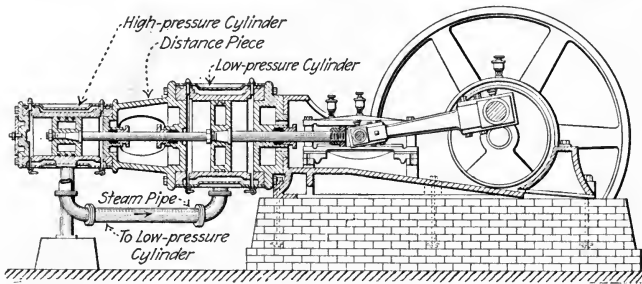

FIG. 378.—Longitudinal section of a typical high-speed tandem-compound engine.

be used for heating, but at other times they are to operate condensing. They are also often used where the initial steam pressure is over 125 lb. per sq. in. The steam pressure at the throttle may run as high as 200 lb. per sq. in. but the temperature should not exceed 400 deg. fahr., with flat slide valves. Compound single-valve engines are nearly always equipped with shaft governors which regulate the steam supply to the high-pressure cylinder, whereas the low-pressure cylinder has its valve driven from a fixed eccentric. Compound single-valve engines are generally built in both tandem and cross types and in sizes up to 1200 h.p.; see Table 337. Figs. 379 to

381 show the steam consumption for these engines. An attempt has been made to show the effects of initial steam pressure, back pressure, and cylinder size. The piston speeds are again about 600 f.p.m.

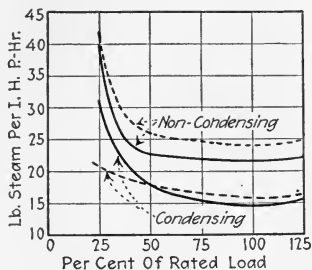

FIG. 379.—Typical steam consumption curves for cross- and tandem-compound engines using steam at 100 lb. per sq. in. gage. The full lines are for an engine of 36-in. stroke whereas the dashed lines are for one of 18-in. stroke.

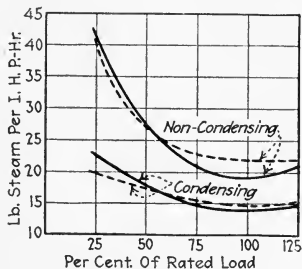

FIG. 380.—Typical steam consumption curves for cross- and tandem-compound engines using steam at 150 lb. per sq. in. gage. The full lines are for engines of 36-in. stroke whereas the dashed lines represent engines of 18-in. stroke.

331. Engines With Riding-Cut-Off Valves (Fig. 184), although once quite popular, are not widely built today. While these engines have their advantages (Sec. 141), their

economy is little better than that of single-valve engines. Engines with riding-cut-off valves are built simple and compound and in sizes up to 2000 h.p. (see Table 337). They may have plate (Fig. 184) or piston (Fig. 185) valves.

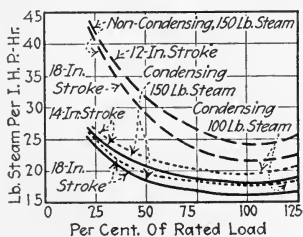

FIG. 381.—Typical steam consumption rates for high-speed, tandem-compound engines. Full lines represent condensing operation with 150 lb. per sq. in. pressure at throttle and 26-in. vacuum. Dotted lines denote the same with 100 lb. steam pressure. Dashed lines refer to non-condensing operation with steam at 150 lb. per sq. in. by gage.

332. Four-Valve Engines (Fig. 235 and Sec. 177) are being made in a large number of forms by different engine builders; see Table 337. The valves may be of the piston (Fig. 382), Corliss (Fig. 238), or poppet type (Fig. 223). The McIntosh & Seymour engine with four flat slide (gridiron) valves (Sec. 142) is no longer manufactured. The poppet-valve engines may be of the so-called "uniflow" (Sec. 334) or of the

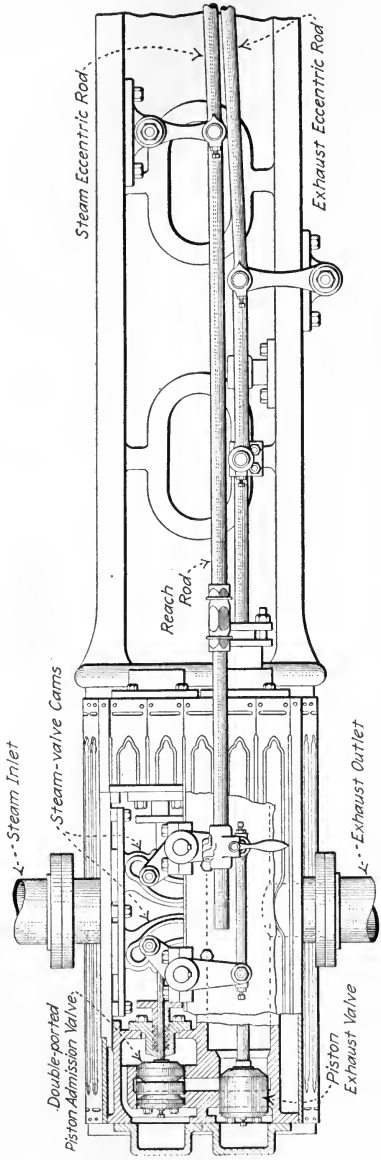

Fig. 382.—Side view of Fitchburg engine showing valve mechanism.

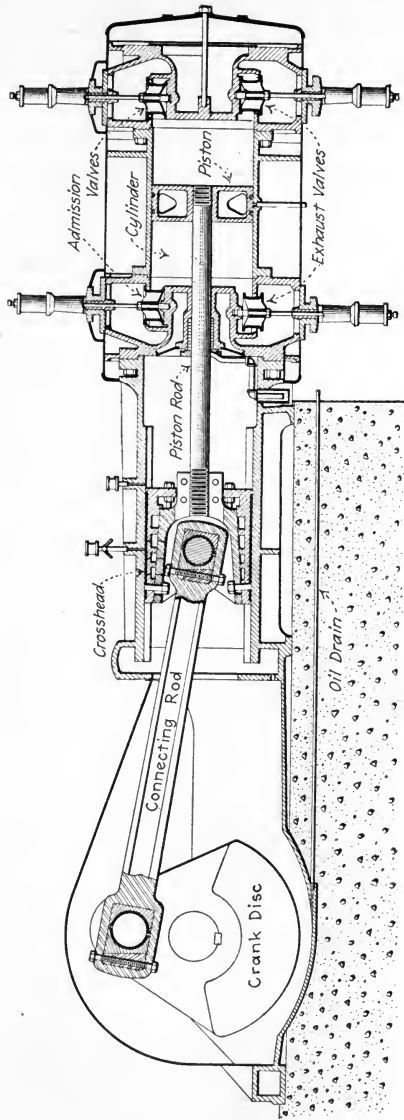

FIG. 383.—Longitudinal section of single-cylinder "Lentz" engine. (Eric City Iron Works.)

“full-poppet” type (Figs. 383 and 384). Strictly speaking, the four-valve uniflow engine does not operate on the original uniflow principle, because some steam is exhausted through auxiliary exhaust valves (see Sec. 334). Four-valve engines of all types (except the “uniflow” type) are built both simple

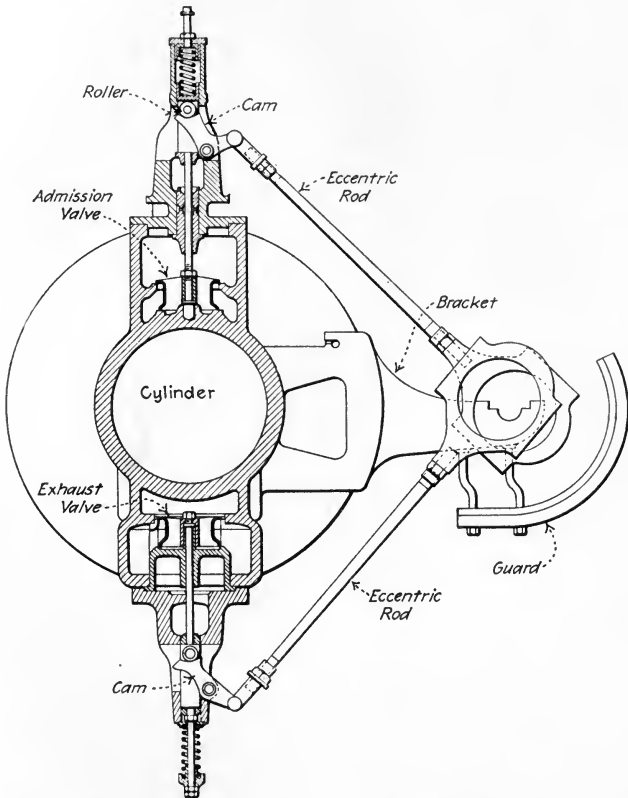

FIG. 384.—Transverse section through valves of “Lentz” engine. (Erie City Iron Works.)

and compound. Nearly all of the detaching Corliss-valve engines (see Div. 5) are equipped with fly-ball governors. All others most often have centrifugal-inertia or shaft governors. Four-valve engines, as a class, have, as stated below, low steam rates as is shown by Figs. 385 to 388. See Sec. 428 for allowable pressures and superheats for these engines.

NOTE.—SIMPLE FOUR-VALVE (CORLISS) ENGINE STEAM RATES (see Fig. 207 for a picture of such an engine), at full load, vary from about 22 to 27 lb. per i.h.p. hr. when operating non-condensing and supplied

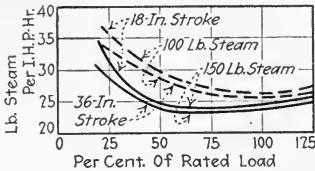

FIG. 385.—Typical steam-consumption curves for simple, non-condensing four-valve engines. Full lines represent rates for engines supplied with steam at 150 lb. per sq. in. gage. Dashed lines refer to operation on steam at 100 lb. per sq. in. gage.

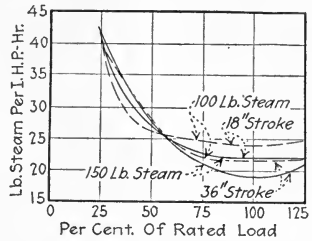

FIG. 386.—Typical steam-consumption curves for compound four-valve engines operating non-condensing. Full lines represent rates for engine supplied with steam at 150 lb. per sq. in. gage. Dashed lines refer to operation on steam at 100 lb. per sq. in. gage.

with steam at 125 to 140 lb. per sq. in. gage. With superheated steam the steam rate may be only about 17 lb. per i.h.p. hr. Typical indicator diagrams from a simple non-releasing Corliss engine are shown in Fig. 389.

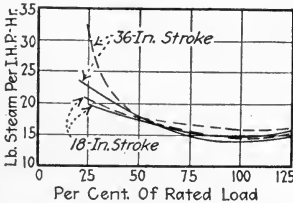

FIG. 387.—Typical steam consumption curves for compound four-valve engines operating condensing with a 26-in. vacuum. Full lines represent rates for engines supplied with steam at 150 lb. per sq. in. gage. Dashed lines refer to operation on steam at 100 lb. per sq. in. gage.

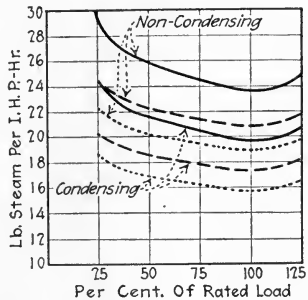

FIG. 388.—Typical steam-consumption curves for single-cylinder poppet four-valve engines of 18-in. stroke when supplied with steam at 100 lb. per sq. in. gage. Full lines represent results with saturated steam; dashed lines correspond to 100 deg. Fahr. of superheat; dotted lines correspond to 200 deg. Fahr. of superheat.

The poppet-valve engine seems to be more economical than the Corliss. Tests have shown non-condensing poppet-valve engines to operate on as little as 18.9 lb. of saturated steam per i.h.p. hr.; and, with superheated

steam (150 lb. per sq. in. gage and 250 deg. fahr.), it is not unusual to get as low as 16 lb. per i.h.p. hr.

NOTE.—THE STEAM RATES OF COMPOUND FOUR-VALVE ENGINES (Fig. 390) at full load when operating non-condensing range from 17 to 22 lb. per i.h.p. hr.; with saturated steam, and as low as 12 lb. per i.h.p. hr. with superheated steam. When operated condensing the steam rate may be as low as 12 lb. per i.h.p. hr., on saturated steam, whereas with superheated steam it has been reduced (see Table 326) to about 9 lb.; these, however, are exceptional values and are, perhaps, 20 per cent. below good average practice.

NOTE.—FOUR-VALVE "UNIFLOW" ENGINES (Figs. 224, 225, and 486)

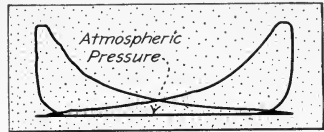

FIG. 389.—Actual indicator diagrams from a 14 by 21-in. Chuse non-releasing Corliss engine in the Rice-Stix Dry Goods Co. plant in St. Louis. Operating conditions when diagrams were taken follow: Initial steam pressure, 160 lb. per sq. in. Exhaust, atmospheric. Speed, 230 r.p.m.

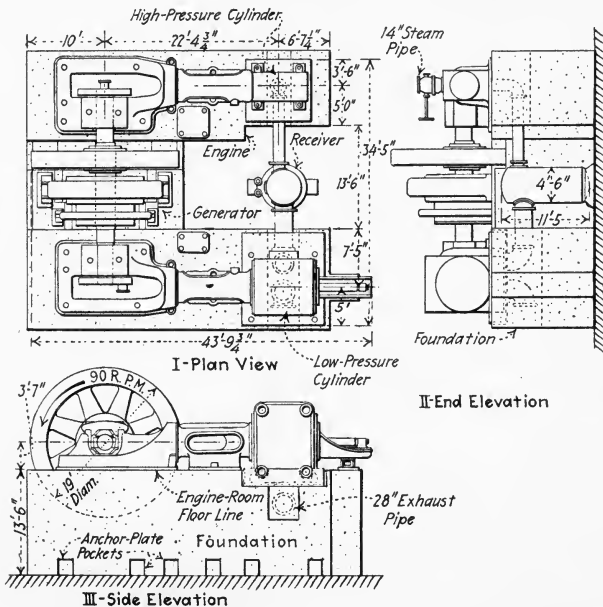

FIG. 390.—Assembly drawing of a cross-compound Fulton-Corliss steam engine. The cylinders are 36 and 76 in. in diameter. The stroke is 54 in.

are generally constructed for non-condensing service. Although most of the used steam is exhausted at the end of the forward stroke through the central exhaust holes in the cylinder wall, more steam is exhausted

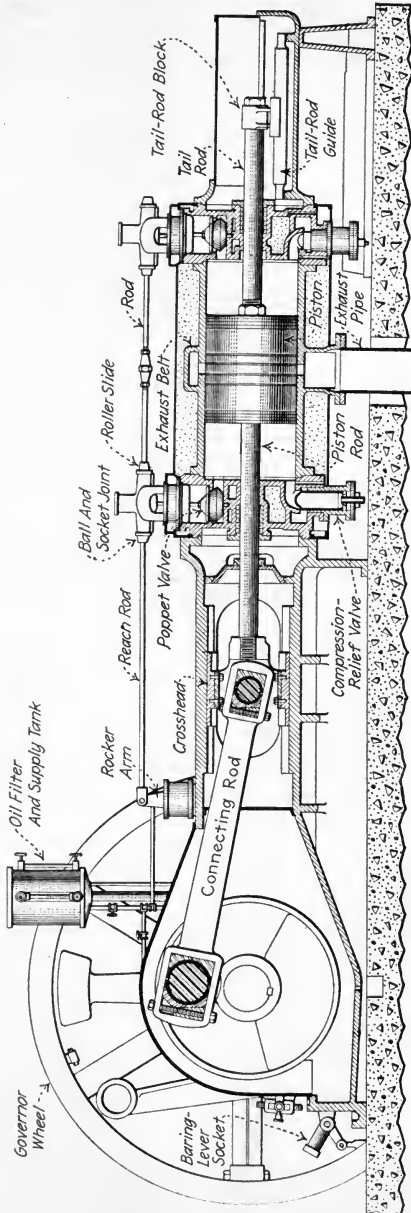

FIG. 391.—Longitudinal section through cylinder of a Chuse uniflow engine. (Chuse Engine & Manufacturing Co.)

during the return stroke through auxiliary exhaust valves. Although such an engine is not truly of the uniflow type, its economy (Fig. 392) is generally somewhat better than that of an engine operating on the true counter-flow principle.

333. The Uniflow Engine (Secs. 59 and 434 and Fig. 391), as originally invented, was intended to be operated *condensing* and to have *no exhaust valves*. The expanded steam should be exhausted through the central port-holes in the cylinder when these holes are uncovered by the piston. When these holes are again covered by the returning piston, the unexhausted steam within the cylinder (at condenser pressure of 1 to 2 lb. per sq. in. abs.) is compressed. Since the compression period is long and the clearance small, the unrejected steam is

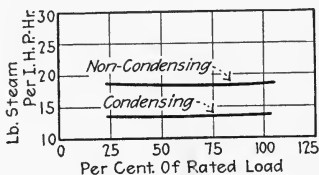

FIG. 392.—Steam-consumption curves for a 21 by 22 in. Skinner "Universal Unaflow" engine supplied with saturated steam at 140 lb. per sq. in. gage.

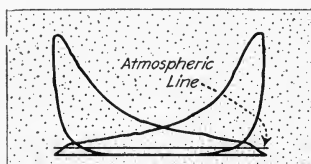

FIG. 393.—Actual indicator diagrams from a 20 by 24-in. Chuse condensing uniflow engine at the Holstead Mill and Elevator Co., Holstead, Kan. The operating conditions under which these diagrams were taken are: Steam supplied at 150 lb. per sq. in. Vacuum in condenser, 23 in. Speed 200 r.p.m.

compressed to a high pressure—usually the pressure at the throttle. The cylinder heads are jacketed with high temperature steam. Thus the unrejected steam is superheated during its compression. Because of this fact and because the colder exhaust steam does not sweep over the warm surfaces near the heads, cylinder condensation is much less in this engine than in a counter-flow engine. Also it has been found that the ratio of expansions within the cylinder can be varied widely without appreciably affecting the economy. This accounts for the small difference (Fig. 392) in the uniflow steam rates between full load and small fractional loads or large overloads. Since the normal cut-off is usually about $\frac{1}{10}$ to $\frac{1}{8}$ stroke, uniflow engines are capable of large over loads. Fig.

393 shows typical indicator diagrams. With saturated steam at moderate pressure the steam rates are about 12 to 15 lb. per i.h.p. hr. With higher pressures and superheat still better economy can be obtained. The record, it seems, is reported by Lentz as 5.67 lb. per i.h.p. hr. with steam at 461 lb. per sq. in. abs. and superheated by 495 deg. to 1,018 deg. fahr.

334. Non-Condensing Uniflow Engines must, of necessity, be built differently from those which are designed to operate only condensing. Modern uniflow engines are frequently designed so that they may be operated either condensing or non-condensing. A uniflow engine designed solely for condensing operation, if operated non-condensing would compress steam from a pressure of about 15 lb. per sq. in. abs. instead of from 1 or 2 lb. The result would be that, if no provision were made to prevent it, the pressure in the engine cylinder would rise during compression to many times the pressure of the incoming steam. To prevent this excessive pressure (which would probably cause rupture of the cylinder)

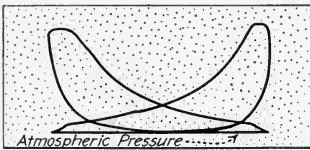

FIG. 394.—Actual indicator diagrams from a 23 by 28-in. Chuse non-condensing uniflow engine at Bridge & Beach Mfg. Co., St. Louis. These diagrams were taken while the operating conditions were: Initial steam pressure, 160 lb. per sq. in. Exhaust, atmospheric. Speed 150 r.p.m.

several schemes are employed.

(1) *The clearance volume may be increased* so that a much greater space is provided to store the compressed steam; engines which are to be operated either condensing or non-condensing are equipped with a small clearance for condensing operation which may be connected by opening a valve with an additional space to provide the necessary

clearance for non-condensing operation—the valve may be automatic (Fig. 244) or hand-operated. (2) *Auxiliary exhaust valves may be employed* to continue the exhaust period during a portion of the return stroke after the main exhaust ports are covered by the piston; these valves may connect into the cylinder at the end (Fig. 486) or into the wall somewhere between the center and end of the cylinder (Fig. 224). Typical indicator diagrams from an engine which has

auxiliary exhaust valves are shown in Fig. 394. Engines of this type which are to be operated either condensing or non-condensing are generally fitted with some means, automatic or manual, for keeping the auxiliary valves closed when operating condensing. (3) *The admission valves may be lifted from their seats or relief valves set to open* when the pressure within the cylinder becomes excessive—thus allowing steam to escape from the cylinder. This means of adapting a condensing engine to non-condensing operation is necessary as a safety measure but is wasteful and, therefore, is not employed during regular running.

NOTE.—THE ECONOMY OF NON-CONDENSING UNIFLOW ENGINES varies somewhat with the design, but with saturated steam at moderate pressures (125 to 150 lb. per sq. in. gage) steam rates of 18 to 25 lb. per i.h.p. hr. may be expected at full load. At partial loads and overloads, the steam rates increase more rapidly than for condensing uniflow engines but still not as rapidly as for counterflow engines. Non-condensing uniflow engines have been run at 250 per cent. of their rated load with only a 25 per cent. greater steam rate than at rated full load. The costs of these engines are given in Sec. 338. They may be safely operated on steam at any pressure and temperature so long as effective lubrication can be maintained (see Sec. 430).

335. The "Locomobile" Is A Type Of Steam Engine (Fig. 395) which is built integral with a boiler which supplies its steam. It was first made in Germany under the name "lokomobile." Many of these units have long been in use in Europe but, until recently, few have been used in this country. The engine is mounted above the boiler and the flue gases are used to jacket the cylinders. Steam is usually generated at a high pressure and superheated. The entire unit is so designed that its efficiency can be maintained very high. The locomobile type of power plant is manufactured in this country under the name *Buckeye-mobile* (see Table 337) which is illustrated in Fig. 395. The engine is a tandem-compound with piston valves; the receiver is placed in the flue-gas path and arranged as a reheater. Typical performance graphs are shown in Fig. 396. By reason of its exceptionally good economy, the locomobile is very well suited for small power plants where good boiler water is scarce and where fuel is expensive.

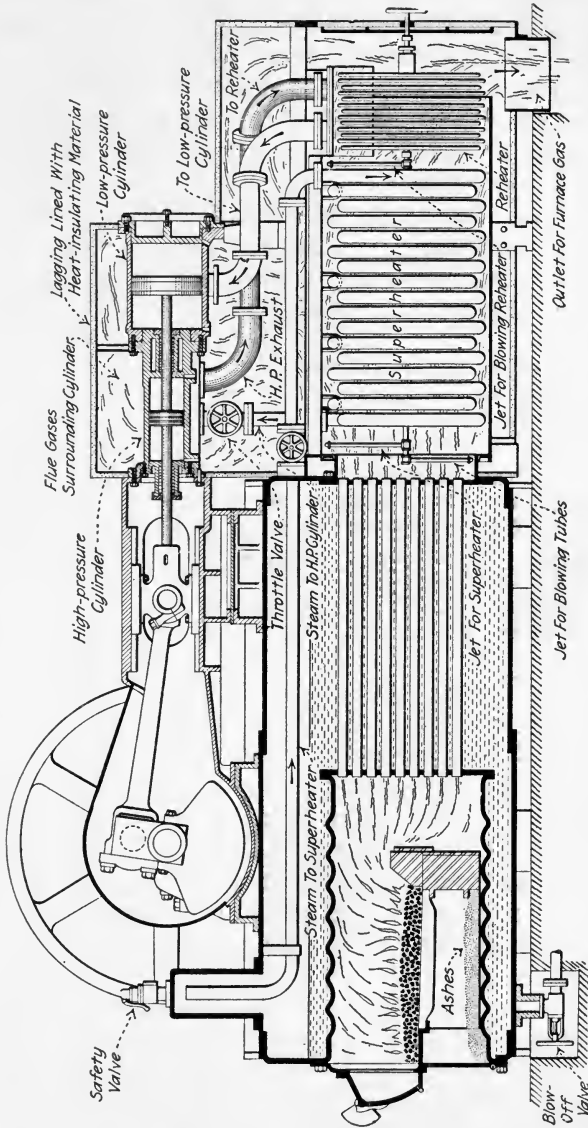

FIG. 395.—Longitudinal section through cylinders and boiler of a Buckeye-mobile. (Buckeye Engine Co.)

336. Steam-Engine First Cost Is Influenced By Many Factors.—In a general way, the cost of an engine depends on its cylinder dimensions and the maximum pressure which the

cylinder will sustain. But, to establish some relation between cost and the power which the engine will develop—that is, to attempt to predict the exact cost of an engine of a certain class and horse power—is almost impossible because of the many influencing factors: (1) *Initial steam pressure* determines the power which an engine will develop—an engine of a given size (and cost) will therefore give most power when supplied with steam at the maximum pressure for which it is

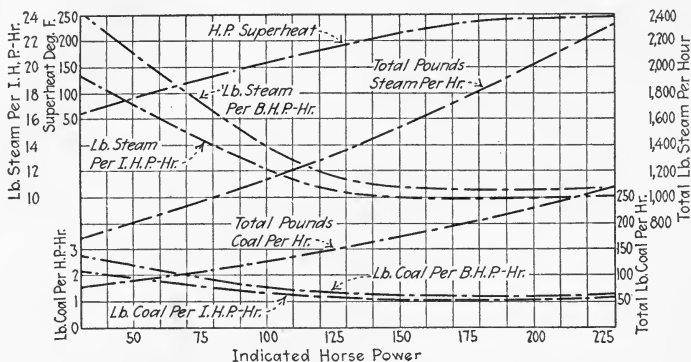

FIG. 396.—Performance graphs of a 150-h.p. Buckeye-mobile. Fuel was Pocahontas run of mine, 14,000 B.t.u. per lb. (Buckeye Engine Co.)

safe. (2) *Speed*, in revolutions per minute, likewise affects the power output—an engine of a given size (and cost) will therefore deliver most power when operated nearest its rated maximum speed. (3) *Back pressure* likewise affects the power output—the lower the back pressure, or if condensing, the greater the vacuum, the greater will be the power output. (4) *The service for which the engine is to be used* affects the necessary construction—engines for driving alternating-current generators must have larger flywheels than those for some other services; engines for direct connection to electric generators usually require longer shafts and different bearing constructions than do those which are to drive by belt or rope; some engines must be designed to operate at variable speeds, some to be readily reversed. (5) *Sub-bases* are sometimes required by the purchaser—sometimes they are not. When required, sub-bases must sometimes have special construction.

337. Table Of Modern Steam Engines Classified As To Type.

Type	Trade name	Manufacturer	Type of valves	Sizes (h.p.)	Speeds (r.p.m.)	Governor	Remarks	Valve gear
Simple single-valve, high and medium speed	Ames Vin	Ames Iron Works, Oswego, N. Y.	Balanced (Sweet)	25-500 10-50	Robb-Armstrong-Sweet Portable	
	Brownell	Brownell Co., Dayton, O.	Balanced	25-305	Rites or throt.	
	Chandler & Taylor	Chandler & Taylor Co., Indianapolis, Ind.	Balanced	35-350	260-130	Throt. or R. A. S.	
	Chuse	Chuse Engine & Mfg. Co., Mattoon, Ill.	Balanced	25-450	Rites	
	Ball	Erie Ball Engine Co., Pittsburgh, Pa.	Balanced (Sweet)	25-800	Robb-Armstrong-Sweet	
	Victor	Erie Engine Works, Erie, Pa.	Balanced	4-200 25-350	Throttling Shaft	
	Liddell-Tompkins		D-slide	12-75	250-150	Throttling	
	Liddell-Chambers	Liddell Co., Charlotte, N. C.	Balanced (Sweet)	35-85 20-200	225-160 350-225	Throttling Rites	
	Liddell		15-150	150	Throttling	
	M. I. W.	Meeklenburg Iron Works, Charlotte, N. C.	Balanced	30-900	Shaft	
	Ridgway	Ridgway Dynamo & Engine Co., Ridgway, Pa.	Balanced	50-600	Shaft	
	Skinner	Skinner Engine Co., Erie, Pa.	Balanced	18-150	220-150	Throttling	
	Southern	Southern Engine & Boiler Works, Jackson, Tenn.	Balanced	25-150	300-200	Rites	
			Rocking	165-410	165-410	Throttling	Single eccentric or equivalent crank
	Troy	Troy Engine & Machine Co., Troy, Pa.	Balanced	2-100 17-200	300-250	Throttling Throttling	Vertical Horizontal	
			Balanced	4-90	600-275	Rites	Vertical	
			Balanced	20-90	475-275	Rites	Horizontal	

Plate or flat valve

Chandler & Taylor	See above	Piston	50-500	300-150	Armstrong	
Engberg	Engberg's Mechanical & Electrical Works, St. Joseph, Mich.	Piston	50-500	300-150	Throttling	Vertical only
Enterprise	Enterprise Company, Columbus, O.	Piston	1-50 kw.	750-150	Shaft or throttling	
Ball	See above	Piston	10-150	350-200	Throttling	
Fleming-Harrisburg	Harrisburg Foundry & Machine Works, Harrisburg, Pa.	Piston	30-250	350-175	Shaft	
Ideal	A. L. Ide & Sons, Springfield, Ill.	Piston	Shaft	
Wachs	E. H. Wachs Co., 1525 Dayton St., Chicago, Ill.	Piston	Fleming	
Ames	See above	Balanced slide	Robb-Armstrong-Sweet	
Chandler & Taylor	See above	Balanced slide	3" X 3" to 14" X 16"	Throttling	Vertical only
Chuse	See above	Balanced slide	80-400	Robb-Armstrong-Sweet	Tandem only
Ball	See above	Balanced slide	70-700	Robb-Armstrong-Sweet	
Ideal	See above	Piston	75-225	Rites	Tandem only
Ridgway	See above	Balanced Slide	50-700	R. A. S.	Tandem
Buckeye	Buckeye Engine Co., Salem, O.	Piston	-1200	R. A. S.	Cross
		Balanced Slide	R. A. S.	
		Piston	30-900	Shaft	Tandem
		Balanced Slide	-1200	Shaft	Cross
		Piston	30-1200	325-75	Shaft	Simple
		Balanced Slide	60-1200	240-75	Shaft	Tandem
		Piston	60-2000	285-75	Shaft	Cross

Low-pressure valve driven from fixed eccentric; high-pressure valve driven from governor eccentric

Exhaust eccentric fixed; steam eccentric on governor

not

Compound single-valve, high and medium speed

Riding cut-off

337. Table of Modern Steam Engines Classified As To Type—(Continued.)

Type	Trade name	Manufacturer	Type of valves	Sizes (h.p.)	Speeds (r.p.m.)	Governor	Remarks	Valve gear
Piston valves	Fitchburg	Fitchburg Steam Engine Co., Fitchburg, Mass.	Piston	30-700 75-650 75-1000	300-80 175-80 200-80	Shaft Shaft Shaft	Simple Tandem Cross	Wrist plates and cams
	Ames	See above	N. R. C.	125-600	225-150	R. A. S.	Simple	Fig. 209
Non-releasing Corliss valves	Chuse	See above	N. R. C.	50-1200	257-120	Shaft	Simple	Fig. 38
	Ball	See above	N. R. C.	100-800	R. A. S.	Simple	Fig. 235
	Fleming-Harrisburg	See above	N. R. C.	Up to 1600 h.p. in compound engines	Fleming	Fig. 236
	Ideal	See above	N. R. C.	Simple and compound types	Gear box on side of frame
	Ridgway	See above	N. R. C.	100-900 100-1500	Shaft Shaft	Simple Compound	Fig. 207
Four-valve	Allis-Chalmers	Allis-Chalmers Mfg. Co., Milwaukee, Wis.	Corliss	100-1400 300-1600	150-100 150-100	Fly-ball Spring-opposed	Simple Compound	Fig. 220
	Cooper	C. & G. Cooper Co., Mt. Vernon, O.	Corliss	30-1500 160-3600	Loaded watt	Simple Compound	Spring or gravity
	Fulton	Fulton Iron Works, St. Louis, Mo.	Corliss	All sizes	Loaded watt	Reynolds trip gear
	Hamilton	Hooven-Owens-Rentschler Co., Hamilton, O.	Corliss	All sizes	60-100	Fly-ball	Gravity (Fig. 214)
	Harris	Franklin Machine Co., Providence, R. I.	Corliss	50-2500	Fly-ball	Reynolds trip gear

VALVES

Detaching Corliss		Murray	Murray Iron Works Co., Burlington, Ia.	Corliss	50-1300 All sizes	Fly-ball (loaded)	Simple Compound	Spring or gravity (Fig. 219)
	Murray Minor	Nordberg	Nordberg Mfg. Co., Milwaukee, Wis.	Corliss	20-70	Fly-ball	Minor	Four types
	Rice and Sargent		Providence Engrg. Corp., Providence, R. I.	Corliss	150-300-10,000	Up to 150.	Sargent	Simple Compound
	St. Louis		St. Louis Iron & Machine Works, St. Louis, Mo.	Corliss	50-1200	90-55	Simple Compound	Reynolds trip gear
	Southern		See above	Corliss	Larger sizes
	Vilter		Vilter Mfg. Co., Milwaukee, Wis.	Corliss	75-1100
	Lentz		Erie City Iron Works, Erie, Pa.	Poppet	75-5000	Simple and compound	Figs. 217 and 218
Poppet-valve counter-flow	Hamilton		See above	Poppet	On lay shaft	Simple and compound	Lay shaft (Fig. 383)
	Nordberg		See above	Poppet	On lay shaft	Fig. 486.
	Vilter		See above	Poppet	Fly-ball	Fig. 41
Uniflow	Ames		See above	4-Poppet	50-1200	R. A. S.	Fig. 226
	Hamilton		See above	4-Poppet	On lay shaft	Fig. 225
	Skinner		See above	4-Poppet	50-1500	Shaft	Lay shaft
Uniflow	Ames		See above	2-Poppet	50-1200	R. A. S.	Reciprocating cams	Fig. 224
	Chuse		See above	2-Poppet	Shaft
	Harrisburg		See above	2-Piston	Fleming	"Dual clearance"	Fig. 391.
Buckeye-mobile	Nordberg		See above	2-Poppet	200-2000	On lay shaft	Fig. 41
	Ridgway		See above	2-Poppet	Shaft	Reciprocating cams
	Buckeye-mobile		Buckeye Engine Co., Salem, O.	Piston	75-600	250-150	Shaft	Tandem compound	Fig. 395

NOTE.—VARIABLE SPEED AND REVERSING ENGINES are also manufactured by many of the engine builders listed in Table 337 but these engines are not listed in the above table.

EXPLANATION.—TABLE 337, although it was intended to contain the names and descriptions of the principal engines manufactured in this country, must be understood to possibly not include all such engines. Furthermore, the fact that a certain engine is or is not included in this table should not be taken to indicate anything whatever with regard to its merits or quality.

338. Table Of Costs Of Steam Engines Of Different Types.—The costs given below must be understood to be merely approximate prices and, because of fluctuations in the market and the factors explained in the preceding section, should be used only in making a preliminary estimate. For a final (or even for a reasonably accurate preliminary) estimate, prices should be obtained from the engine manufacturers. The prices given below are as of January 1, 1922, for engines without special bases and arranged for belt drive from the flywheel.

Type of engine	Cost of engine per horse power	
	Small engine	Large engine
Simple slide-valve.....	\$22-44	\$11-16
Compound slide-valve.....	22-33	15-17
Simple four-valve.....	25-37	9-18
Compound four-valve.....	35-45	16-25
Uniflow.....	32-45	12-21

QUESTIONS ON DIVISION 11

1. Explain the differences between rotary steam engines and (1) reciprocating engines (2) steam turbines.
2. Explain, with a sketch, the operation of a rotary steam engine. What are its shortcomings? Is it widely used?
3. What are the usual sizes and rotative speeds of simple single-valve engines? What is their field of service?
4. What steam rate may usually be expected from simple single-valve non-condensing engines at full load? At fractional loads?
5. What is the most advisable cut-off for a simple non-condensing single-valve engine? What is the customary piston speed?
6. What are *portable steam engines*? What is their field of service? In what sizes are they commonly built?

7. In what sizes and forms are compound single-valve steam engines commonly manufactured? What is their field of service?

8. What steam consumptions may reasonably be expected of compound single-valve engines when operated non-condensing? When operated condensing?

9. Name a well-known make of riding-cut-off piston-valve engines. In what sizes are they manufactured?

10. What forms of valves are employed in four-valve engines? What types of governors do they employ?

11. What are the common water rates of simple four-valve engines with Corliss valves? With poppet valves?

12. What is the principle of the *uniflow* engine? Wherein does it derive its great economy?

13. Name and describe two ways in which a uniflow engine may be constructed so as to satisfactorily operate non-condensing.

14. What safety device is relied on to automatically adapt to non-condensing operation, if the vacuum is destroyed, uniflow engines which are designed primarily to operate condensing?

15. What are the usual steam rates of condensing and non-condensing uniflow engines? What exceptional rate has been reported?

16. Are uniflow engines capable of carrying large overloads? Why?

17. How does the steam consumption per indicated horse power hour of a uniflow engine at fractional and overloads compare with that at full load? In this respect, how does the uniflow engine compare with other engines?

18. What is a *locomobile*? With a sketch describe its construction. What is its field of service? Why? What water rate may be expected with this unit?

19. What are the principal factors which will influence the cost of a steam engine of any class, for a given power output?

20. Which would you expect to cost more per horse power, a small engine or a large engine? A high-speed engine or a low-speed engine? A high-pressure engine or a low-pressure engine? A condensing engine or a non-condensing engine? An engine to drive an alternating-current generator or one for a mill?

21. State approximate costs of engines of the different classes.

DIVISION 12

STEAM-ENGINE TESTING

339. The Purposes Of Testing Steam Engines are to determine any or all of the following: (1) *The operating conditions.* (2) *The mechanical efficiency.* (3) *The water rate.* (4) *The thermal efficiency.* The purposes of the different types of tests, the apparatus required, the method of procedure, and the calculation of the test results are all discussed in the following sections of this division.

340. The Purpose Of An Operating-Condition Test is to ascertain whether the engine valves are functioning properly and to determine mechanical defects that may exist within the engine cylinder. Tests of this type involve only the use of steam-engine indicators and correct interpretations of the indicator cards which are obtained in the test (see Div. 3 for discussion of indicators and indicator cards).

341. The Purpose Of A Mechanical-Efficiency Test (see Div. 10) is to determine the energy lost in friction in the various bearing surfaces of the engine. This energy loss is called the *friction horse power*. The methods of conducting such a test are discussed in Secs. 368 and 369.

NOTE.—See Div. 3 for discussion and rules for calculation of indicated horse power. Methods of determining the brake horse power are described in subsequent sections.

342. The Purpose Of A Water-Rate Test is to determine the quantity of steam, and thereby the quantity of heat, used by an engine per indicated or brake horse power. This type of test will therefore provide a suitable basis for comparing one engine with another with respect to steam economy. The methods of conducting a water-rate test are described in Secs. 370 to 373.

343. The Purpose Of A Thermal-Efficiency Test is to classify the various heat losses of an engine according to the manner

in which the loss occurs. Thus, the energy loss due to the rubbing contact of bearings can be found in this type of test and classified as a *friction loss*. Also, as stated in Sec. 318, the thermal efficiency of an engine is a much better measure of its performance than is its water rate, because the water rate depends upon operating conditions. It is therefore apparent that a thermal efficiency test is valuable to the engine designer and builder in that it presents knowledge essential to the designing and building of efficient engines. Thermal efficiency test methods are considered in Sec. 374.

NOTE.—THE THERMAL EFFICIENCY IS GENERALLY CALCULATED IN WATER-RATE TESTS and is calculated from the results obtained in a water-rate test.

344. The General Procedure In Engine Testing consists of operating the engine for sufficient time and under suitable conditions to determine the amount of (1) *heat energy supplied* to the engine and the amount of (2) *mechanical energy developed and delivered* by the engine. The determination of these two fundamental quantities ordinarily involves the collection of data as tabulated below.

345. Table Showing Data Necessary In An Engine Test.

Quantity sought	Data required
Heat input	<ul style="list-style-type: none"> (a) Pressure of steam supplied to the engine. (b) Condition (quality or superheat) of steam supplied to the engine. (c) Weight of steam rejected by (or supplied to) the engine. (d) Pressure of steam as it is rejected by the engine. (e) Weight of the drip from each jacket. (f)¹ Temperature of the water entering and leaving the condenser and weight of circulating water.
Mechanical energy output	<ul style="list-style-type: none"> (a) Speed of the engine, in revolutions per minute. (b) Indicator diagrams from each end of each cylinder. (c) The engine's brake horse power (dynamometer or electric generator measurement).

¹ When a heat-balance (Sec. 12) is to be made.

346. The Equipment Required For Engine Testing depends upon the type of test being made. In general, the most essential instruments are: (1) *Pressure and vacuum gages*. (2) *Barometers*. (3) *Thermometers*. (4) *Steam calorimeters*. (5) *Steam-engine indicators*. (6) *Planimeters*. (7) *Tachometers or revolution counters*. (8) *Dynamometers*, or other load-measuring apparatus. (9) *Steam condensers* for condensing exhaust steam. (10) *Scales* for weighing the condensed steam. The more important of these instruments will now be described.

NOTE.—Pressure and vacuum gages, barometers, thermometers, and steam calorimeters are described in the author's PRACTICAL HEAT. Indicators and planimeters have been discussed in Div. 3.

347. A Revolution Counter (Figs. 397 and 399) is an instrument which indicates the number of revolutions made during a period of time by a rotating shaft or wheel. To determine the speed in revolutions per minute with a revolution counter, it is only necessary to divide the total number of revolutions made during the period of time by the time period expressed in minutes.

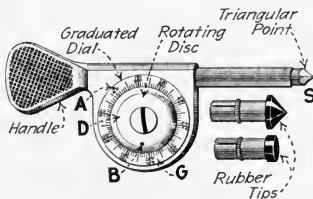

FIG. 397.—Hand revolution counter.

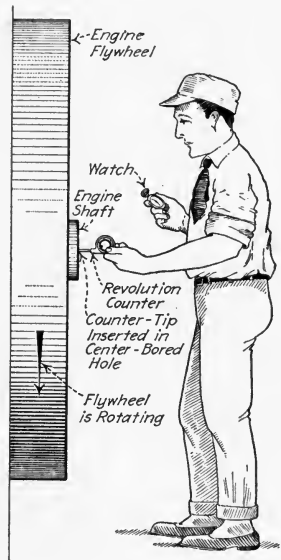

FIG. 398.—Counting revolutions of an engine with a revolution counter.

348. A Hand Revolution Counter is shown in Fig. 397. It consists of a rotating disk, *D*, connected through worm gearing to a short triangular-pointed stem, *S*, which is provided with detachable rubber tips. In counting revolutions (Fig. 398), *S* (Fig. 397) is inserted in the center-bore of the

crank shaft of the engine under test and it thus turns with the shaft causing *D* to revolve. Simultaneously, the operator looks at his watch to keep an accurate account of the time. Ordinarily the counter is permitted to run for 1 min. The operator, looking at the second hand of his watch, inserts the rubber tip in the center-bore at the start of a minute and removes it at the end of the minute. For each 100 revolutions of *S*, *D* makes 1 revolution. In counting, the operator holds his thumb over the small stationary button, *A*, and "feels" each revolution of the rotating button, *B*, which is attached to *D*. The rubber tips are used to prevent slipping at high speeds. This type of revolution counter can be used satisfactorily for speeds up to 1200 r.p.m.

349. A Continuous Revolution Counter (Fig. 399) is generally attached permanently to an engine. The operating arm, *A*, is usually connected by a lever to some engine part having a limited reciprocating motion. The instrument is essentially a stroke counter constructed to add one to the dial reading for every two strokes of the engine. This type of revolution counter may be used satisfactorily on engines having speeds up to 250 or 300 r.p.m.

350. A Tachometer (Figs. 400 and 401) is an instrument which registers the speed of the shaft under consideration in revolutions per minute, directly and at any instant. Thus, the variations in its indications from instant to instant will show the different shaft speeds

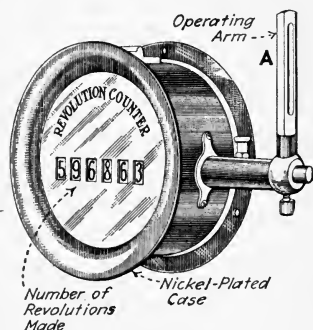

Fig. 399.—Continuous revolution counter (Foxboro Mfg. Co.)

at different instants. Tachometers are most satisfactory for the higher speed ranges such as those which are attained in steam-turbine practice, but they may also be used on high-speed engines. They are manufactured to measure speeds as low as 20 and as high as 20,000 r.p.m. However, because of the unavoidable instantaneous variations in the rotative speeds of steam engines, tachometers are entirely unsuitable for engine-speed measurements lower than, say, 300 r.p.m.

In fact, some engineers would not use tachometers for measuring steam-engine speeds.

351. A Fixed Tachometer (Fig. 400) is fastened permanently to some part of the engine frame and is belted from the pulley, *B*, to the engine shaft. The mechanism consists of a spring-opposed centrifugal governor, the movement of which directly actuates the pointer, *P*.

352. A Hand Tachometer (Fig. 401) is a governor-operated device internally geared to allow three distinct speed-range adjustments. Adjustment is accomplished by loosening the

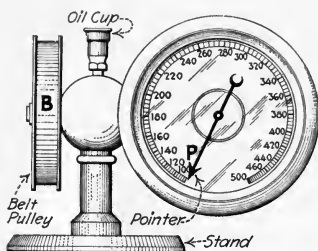

FIG. 400.—Fixed tachometer (Schaeffer & Budenburg Mfg. Co.)

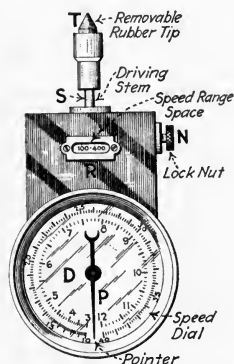

FIG. 401.—Hand tachometer. (Foxboro Mfg. Co.)

locknut, *N*, and pulling out (or pushing in) the driving stem, *S*, until the desired speed range is indicated in space *R*. Then *N* is tightened. The speed is indicated by the pointer, *P*, on either the inner or outer graduated circles depending upon the speed range in use.

353. Dynamometers Or Load-Measuring Apparatus are of extreme importance in engine testing and may be divided into two general classes: (1) *Absorption dynamometers*. (2) *Electric generators*. These are discussed separately in following sections. In *acceptance* or *factory tests* of engines, it is usually necessary to so “load” the engine that it will operate at its rated-horse-power output and possibly also at other outputs below and above the rated output. The load-measuring apparatus provides means whereby this loading can be

readily effected and measured—whereby the engine can be made to do work at a known rate.

354. Absorption Dynamometers, Or Brakes, are of two general types: (1) The *Prony brake type* (Figs. 402 to 406), wherein the power is absorbed by friction due to a rubbing contact of solid substances. (2) The *fluid-friction type* (Fig. 409), wherein the power is absorbed by friction due to the turbulence or viscosity of fluids.

355. The Prony-Brake Absorption Dynamometer (Fig. 402) consists of a steel strap, *S*, bent to conform to the shape of the

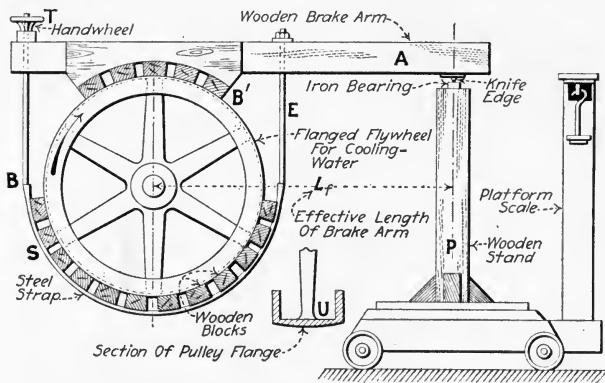

FIG. 402.—Typical Prony brake.

flywheel of the engine under test and to which wooden blocks, *B*, are fastened as shown. The steel strap is rigidly held at one end, *E*, to the brake arm, *A*, on one side of the flywheel and is fastened at its other end to a “take-up” device, *T*, on the other side of the flywheel. The frictional force exerted by the brake can be adjusted by means of the hand-wheel on the “take-up” device. A portable brake for testing very small machines is shown in Fig. 403.

NOTE.—COOLING OF THE PRONY BRAKE is sometimes essential to prevent the wooden blocks from burning due to heat generated by their friction on the flywheel rim. Effective cooling can be accomplished by playing a small stream of water upon the inside of the flywheel. Some flywheels and pulleys are flanged as shown in Figs. 402 and 406; the U-shaped space, *U*, Fig. 402, thus formed can be filled with cooling water. As the water heats and evaporates, it can be replenished.

NOTE.—LUBRICATION OF THE PRONY BRAKE is sometimes necessary to prevent chattering and seizing of the brake shoes. Grease or heavy oil placed between the brake blocks on the face of the flywheel at its top will lessen to a great extent the tendency to seize or chatter.

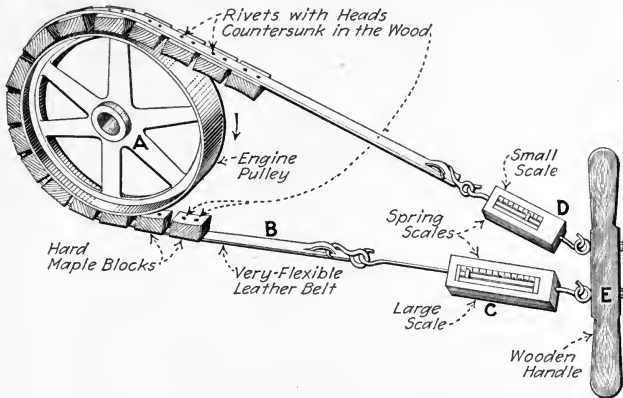

FIG. 403.—A portable Prony brake for testing very small engines. (In testing, *E* is pulled until the braking effect is sufficient. Then the *D* reading is subtracted from the *C* reading. The remainder multiplied by the peripheral speed of *A*, in feet per minute, gives the foot pounds per minute. This value divided by "33,000" gives the horse power. E. E. Larson in *Power*, Sept. 13, 1917.)

356. The Use Of A Dynamometer Of The Prony-Brake Type Necessitates The Determination Of Constants called the effective length of brake arm and the tare-weight of the brake.

The tare-weight " W_1 " is its unbalanced weight, due to its unsymmetrical construction. This weight can be found by two methods: (1) *Dummy Flywheel Method*.—A wooden templet, *T* (Fig. 404), which has the same diameter as the flywheel of the engine which is to be tested, is made. The brake is then mounted on this templet as shown and supported on saw-horses, *S*, by a shaft made of pipe, *P*, so that the brake arm is in the same horizontal position as for testing. The knife-edge is supported on the stand, *B*. Then, both the stand and the brake are weighed on the scale, *W*.

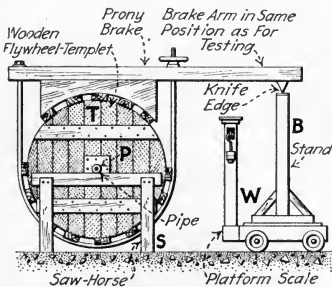

FIG. 404.—Method of determining tare-weight of a Prony brake using a wooden templet of flywheel. (The templet is free to roll on the pipe *P*.)

pipe, *P*, so that the brake arm is in the same horizontal position as for testing. The knife-edge is supported on the stand, *B*. Then, both the stand and the brake are weighed on the scale, *W*.

This scale reading will be the tare-weight, " W_1 ," of the brake. (2) *Rotation Method*.—Arrange the brake as shown in Fig. 402 and loosen the blocks on the flywheel until the flywheel turns easily. Turn the flywheel by hand in one direction for one or two revolutions and weigh the brake while turning the flywheel. Turning the flywheel in the opposite direction, weigh again. The average of these two weights (one-half their sum) will be the tare-weight, " W_1 ," of the brake. The determination of the tare-weight by this method should be made two or three times to insure a fair average. Any stand or pedestal used with the brake, for example, P , Fig. 402, must be weighed with the brake when determining the tare-weight.

NOTE.—THE EFFECTIVE LENGTH OF THE BRAKE ARM, L_f (Fig. 402), is the horizontal distance, in feet, between the vertical center line of the knife-edge and the vertical center line of the flywheel when the brake is in the working position.

357. When Using An Absorption Dynamometer, The Brake Horse Power Is Calculated By The Formula (its derivation is given below):

$$(41) \quad P_{bhp} = \frac{2\pi L_f N (W - W_1)}{33,000} \quad (\text{h.p.})$$

Wherein: P_{bhp} = brake horse power developed. L_f = effective length of brake arm, in feet, as defined in Sec. 356. N = the engine speed, in revolutions per minute. W = the gross load on the scale, in pounds, as indicated by the scale during the test. W_1 = the tare-weight of the brake, in pounds, as described in Sec. 356. The term $(W - W_1)$ is frequently called the *net-weight* of the brake.

DERIVATION.—Assume that the flywheel is held stationary on a vertical axis, and that the brake arm is pushed around the flywheel (Fig. 405) with a force of $(W - W_1)$ pounds. This, obviously, is the force which is required to rotate the brake. The distance through which this force will act in one revolution = *the circumference of a circle of radius L_f ft.* = $2\pi L_f$ ft. Since N = r.p.m., the distance traveled in one minute by the friction sides of the brake blocks will be $2\pi L_f N$ ft. Hence, since the force $(W - W_1)$ acts through the distance of $2\pi L_f N$ ft. in one minute, the work done per minute will be *distance per minute* \times *force* = $2\pi L_f N (W - W_1)$ ft. lb. per minute. Now it is evident that work will be

performed at the same rate by the flywheel when it is revolving within the stationary brake blocks as when the brake blocks are revolving (pushed) around the stationary flywheel, the speed being the same in both cases. Then, since by definition *horse power = foot pounds of work done per minute* ÷ 33,000, it follows that:

$$(42) \quad P_{bhp} = \frac{2\pi L_f N (W - W_1)}{33,000} \quad (\text{h.p.})$$

which is the same as for For. (41).

EXAMPLE.—An engine runs at a speed of 270 r.p.m. and its Prony brake and stand push down with a force of 250 lb. on a platform scale. If the tare-weight of the brake is 40 lb. and the effective brake-arm

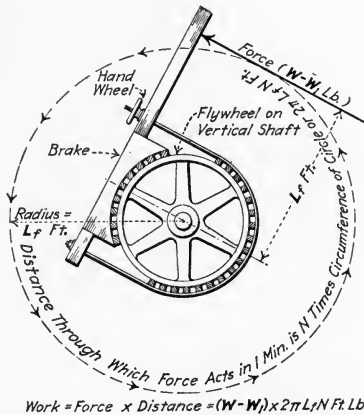

FIG. 405.—Illustrating derivation of brake formula. Work in foot pounds = Force in pounds × Distance in feet = $(W - W_1) \times 2\pi L_f N$.

length is 4 ft. 6 in., what brake horse power is developed by the engine? SOLUTION.—Substituting in For. (41): $P_{bhp} = 2\pi L_f N (W - W_1) / 33,000 = 2 \times 3.14 \times 4.5 \times 270(250 - 40) \div 33,000 = 48.6 \text{ b.h.p.}$

358. A Rope Brake Absorption Dynamometer (Fig. 406) is a form of the Prony brake in which a rope is used instead of wooden blocks to provide frictional resistance. The *effective brake-arm length* of a rope brake (L_f , Fig. 407) is the radius of the flywheel plus the radius of the rope. Those portions of the rope between the flywheel and the rope ends must, in a brake of the type shown in Fig. 406, be vertical.

EXPLANATION.—Considering the rope (Fig. 407) of a rope brake, without the stand, the force due to the frictional resistance of the rope is

transmitted to the scale as though it were carried through the center line of the rope end *A* to the scale. Hence the effective brake-arm length is the horizontal distance from the vertical center line of the flywheel to the

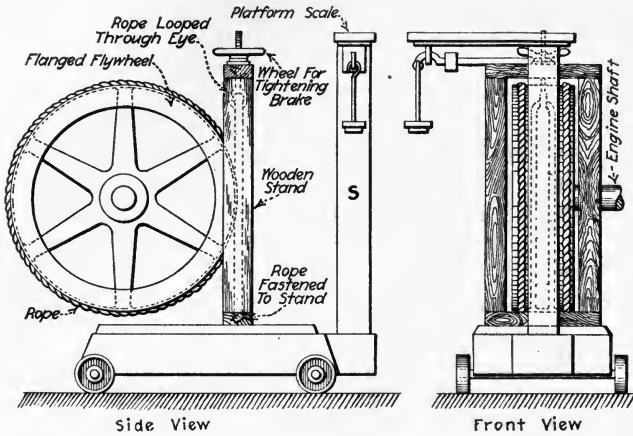

FIG. 406.—Typical rope brake on platform scale, *S*.

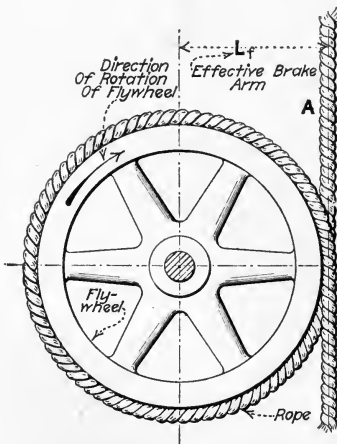

FIG. 407.—Illustrating effective brake-arm of a rope brake.

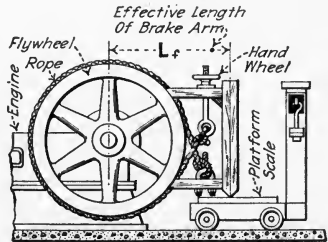

FIG. 408.—A rope brake. (The effective brake-arm length of this brake is measured between the same points as for a Prony brake. (See Fig. 402.)

center line of the rope, or the distance L_f . Fig. 408 shows a rope brake of another type, for which the effective length of brake arm is found in the same way as for a wooden-block Prony brake.

EXAMPLE.—A rope brake (Fig. 406) made of 1-in. rope is installed on an engine with a 4-ft. diameter brake wheel. A load of 480 lb. is balanced on a platform scale when the engine is operating at 200 r.p.m. If the tare-weight of the brake is 80 lb., what is the brake horse power of the engine? SOLUTION.—The effective brake-arm length, $L_f = (4 + \frac{1}{2})/2 = 2 + \frac{1}{4} = 2.0417$ ft. From For. (41): $P_{bhp} = 2\pi L_f N (W - W_1)/33,000 = 2 \times 3.14 \times 2.0417 \times 200(480 - 80) \div 33,000 = 31.15$ h.p.

359. The Water Brake Is A Dynamometer Of The Fluid-Friction Type (Fig. 409).—The principle of operation of the water brake is similar to that of the centrifugal pump. The

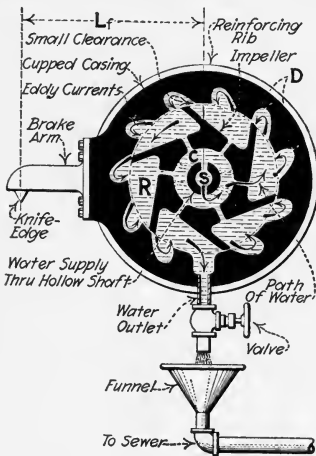

FIG. 409.—Illustrating principle of the water brake.

chief difference is that the centrifugal pump is designed to offer the least possible resistance to the passage of water, while the water brake is designed to offer the greatest possible resistance. This resistance is introduced by cupping the casing and constricting the water-outlet areas. The rotor (impeller) of the water brake is coupled to and rotates with the shaft of the engine under test. The stationary part is equivalent to the brake arm of a Prony brake.

EXPLANATION.—Water is admitted to the impeller chamber, *C*, through the hollow shaft, *S*. This water is then, by centrifugal force, forced out radially through the holes in the impeller to the spaces, *R*, between the impeller arms. As these arms rotate, the water is thrown into the cups, *D*, in the stationary casing wherein eddy currents are formed. These eddy currents oppose the rotation of the impeller and thereby cause the knife-edge to press down on the scale. The water eventually finds its way through the small clearances between the impeller and casing to the water outlet. The water pressure in the brake can be adjusted to meet various load conditions by throttling the valves on the water inlet and outlet pipes. The greater the pressure within the casing, the greater the load which it imposes on the scale.

NOTE.—THE BRAKE HORSE POWER ABSORBED BY A WATER BRAKE is found by For. (41). The effective-brake-arm length (L_f , Fig. 409) is

found as with a Prony brake. The tare-weight of this brake is found by Method 2 in Sec. 356.

360. Electrical Loading Of An Engine (Fig. 410) is accomplished by coupling or belting an engine to an electric generator of *known efficiency* (Sec. 362) and measuring the power output of the generator. The generator is connected to a variable electrical load—usually a water rheostat—whereby the power required of the engine to drive the generator can be varied at the will of the operator. Either an alternating-current (A.C.) or a direct-current (D.C.) generator may be used.

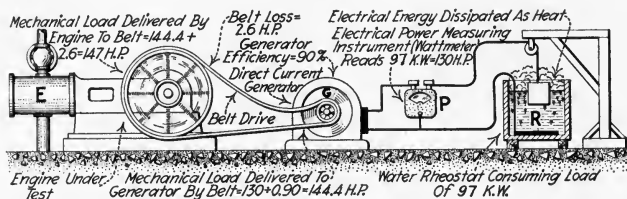

FIG. 410.—Illustrating principle of electrical loading of an engine (Engine, E, is pulling 147 mechanical h.p. Of this, the electrical load on generator, G, which is indicated on P, and which is dissipated in water rheostat, R, comprises 97 kw. or 130 h.p.)

NOTE.—WHEN GENERATORS ARE BELTED TO ENGINES ALLOWANCE MUST BE MADE FOR SLIPPAGE OF THE BELT. This allowance can be made by the following formula, the derivation of which is given below.

$$(43) \quad P_{bhp} = \frac{N'' d_i''}{N' d_i'} P_{hp} \quad (\text{h.p.})$$

Wherein: P_{bhp} = brake horse power of engine. N'' = speed of engine in revolutions per minute. d_i'' = diameter of engine pulley, in inches. N' = speed of generator pulley, in revolutions per minute. d_i' = diameter of generator pulley, in inches. P_{hp} = horse power input to generator (Sec. 362).

DERIVATION.—The horse power transmitted by a belt = (the net belt pull—the force transmitted—in pounds) \times (the distance, in feet, through which the force acts in one minute) \div 33,000. That is, 1 h.p. = 33,000 ft. lb. per min. The distance through which the net belt pull acts in one minute is the circumference, in feet, of the pulley over which it runs times the number of revolutions it makes in one minute. That is, if the pulley diameter is expressed in inches, the distance = $N'' \times \pi \times d_i'' / 12$. Hence the horse power transmitted to a belt by its engine pulley can be expressed by the formula:

$$(44) \quad P_{bhp} = \text{Net belt pull} \times N'' \times \pi \times d_i'' / (12 \times 33,000) \quad (\text{h.p.})$$

Transforming this equation for the engine pulley, it becomes:

$$(45) \quad \text{Net belt pull} = \frac{12 \times 33,000 \times P_{bhp}}{\pi N'' d_i''} \quad (\text{lb.})$$

If For. (44) represents the brake horse power given to the belt by the engine which drives the belt, similarly the net horse power given to the generator by the belt can be represented by:

$$(46) \quad P_{hp} = \text{Net belt pull} \times N' \times \pi \times d_i' / (12 \times 33,000) \quad (\text{h.p.})$$

From which it follows that, for the generator pulley:

$$(47) \quad \text{Net belt pull} = \frac{12 \times 33,000 \times P_{hp}}{\pi N' d_i'} \quad (\text{lb.})$$

Since the net belt pull at the engine is the same as, and equal to, the net belt pull at the generator, Fors. (45) and (47) may be equated, thus:

$$(48) \quad \text{Net belt pull} = \frac{12 \times 33,000 \times P_{bhp}}{\pi N'' d_i''} = \frac{12 \times 33,000 \times P_{hp}}{\pi N' d_i'} \quad (\text{lb.})$$

or transposing and dividing by $12 \times 33,000$ and multiplying by π

$$(49) \quad P_{bhp} = \frac{N'' d_i''}{N' d_i'} P_{hp} \quad (\text{h.p.})$$

Which is the same as For. (43).

EXAMPLE.—A generator having a 2-ft. diameter pulley was driven by a belt from an engine having a 6-ft. diameter flywheel. If the speed of the engine was 200 r.p.m. at 90 h.p. *input* to the generator and the speed of the generator was 585 r.p.m. at this load, what was the brake horse power of the engine? SOLUTION.—From For. (43): $P_{bhp} = (N'' d_i'' / N' d_i') P_{hp} = [(200 \times 72) \div (585 \times 24)] \times 90 = 92.4 \text{ b.h.p.}$

361. To Determine The Electrical Output Of A Direct-Current Generator (Fig. 411) the procedure is as follows:

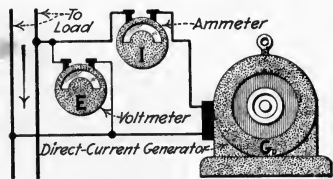

FIG. 411.—Illustrating load-output determination of a direct-current generator, G_D . Using ammeter, I , and voltmeter, E .

A voltmeter, E , to measure the difference in electric potential (e.m.f.) between the leads, is connected in parallel with the load; see Sec. 365 for "Water Rheostat." An ammeter, I , to measure the current flowing through the leads, is inserted in series with the load. The ammeter and the voltmeter are read at the same instant. The *power output of the generator* in kilowatts is then found by substituting the observed values in the following formula:

$$(50) \quad P_{kw} = \frac{EI}{1000} \quad (\text{kw.})$$

Wherein: P_{kw} = the power-output of the generator, in kilowatts. E = the voltage or e.m.f., in volts, as indicated by the voltmeter. I = the current, in amperes, as read from the ammeter at the same instant the voltmeter is read.

NOTE.—A DIRECT-CURRENT WATTMETER MAY BE USED (P , Figs. 410 and 412) instead of a voltmeter and an ammeter. It is connected as shown and reads directly the product EI (For. 50).

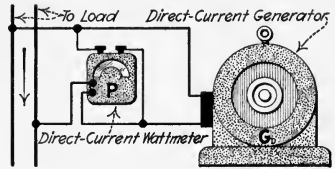

FIG. 412.—Illustrating load-output determination with a direct-current generator, G_D , using a direct-current wattmeter, P . (Note.—Single-phase alternating-current generator load determinations may be made as illustrated if an alternating-current wattmeter is used instead of a direct-current wattmeter as shown.)

362. To Find The Horse-Power Input To Any Generator When Its Power Output Is Known (1 h.p. = 0.746 kw.) substitute in the formula:

$$(51) \quad P_{hp} = \frac{P_{kw}}{0.746E_d} \quad (\text{h.p.})$$

Or since, for direct-current generators, For. (50): $P_{kw} = EI/1000$, it is true for direct-current generators that:

$$(52) \quad P_{hp} = \frac{EI}{746E_d} \quad (\text{h.p.})$$

Wherein: P_{hp} = the horse-power input to the generator. E_d = the efficiency of the generator at the developed load, expressed decimally.

NOTE.—THE EFFICIENCY OF A GENERATOR AT ANY LOAD CAN BE READ FROM ITS EFFICIENCY GRAPH. This graph is usually plotted between *per cent. load* and *per cent. efficiency* or between *amperes load* at rated voltage and *per cent. efficiency*. The graph can be obtained from the manufacturer of the generator by giving the serial number and all other name-plate data relating to the machine.

EXAMPLE.—A steam engine is coupled to and driving a direct-current generator, G_d , Fig. 411. If the voltmeter, E , reads 220 volts, the ammeter I , 764 amp., and the efficiency of the generator at this load, as shown by its efficiency graph, is 0.90, what is the horse-power input of the engine to the generator? SOLUTION.—By For. (52): $P_{hp} = EI/746E_d = 220 \times 764 \div (746 \times 0.90) = 250 \text{ h.p.}$

363. To Determine The Electrical Load With A Single-Phase, Or Two-Phase, Alternating-Current Generator (Figs. 413 and 414) use an alternating-current wattmeter, P , in each

phase which will read P_{kw} directly for that phase. The total output of a two-phase generator is always the sum of the wattmeter readings for each of the two phases. The horsepower input is found by For. (51). For a single-phase alternating-current circuit an alternating-current wattmeter may be connected in the same way (Fig. 412) as is a wattmeter on a two-wire direct-current circuit.

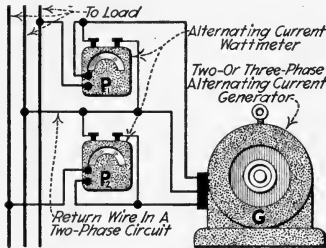

FIG. 413.—Method of determining power output of a 3-wire, 2-phase alternating-current generator, *G*. (Note.—The power of a 3-wire 3 phase, alternating-current generator may also be determined as illustrated above.)

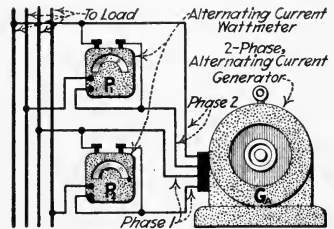

FIG. 414.—Method of determining power output of a 4-wire, 2-phase, alternating-current generator, *G_A*.

NOTE.—IN A THREE-WIRE TWO-PHASE SYSTEM always be sure that the connections are made as shown in Fig. 413; that is, with a wattmeter current coil in each of two lead wires and the voltage coils of each wattmeter connected to the common return wire.

EXAMPLE.—If wattmeter P_1 (Fig. 413) reads 30 kw. and wattmeter P_2 reads 35 kw., what is the horsepower input of the engine to the generator, if the generator efficiency at this load is 0.88?

SOLUTION.—The total power output of the generator in kilowatts, P_{kw} = the sum of the wattmeter readings = $P_1 + P_2 = 30 + 35 = 65$ kw. The horse power input to the generator from For. (51) is: $P_{hp} = P_{kw} / 0.746E_d = 65 \div (0.746 \times 0.88) = 96$ h.p.

364. To Determine The Electrical Load With A Three-Phase Alternating-Current Generator (Fig. 413) two alternating-current wattmeters, P_1 , and P_2 , are connected in any two of the three phases. The sum of the readings of the two wattmeters will be the total output, P_{kw} , of the generator. To determine the horsepower input to the generator substitute in For. (51).

NOTE.—IN USING TWO WATTMETERS IN A THREE-WIRE, THREE-PHASE ALTERNATING-CURRENT CIRCUIT neither of the meters measures the power in any one of the three phases. With light loading one of the meters will probably give a negative reading, and it is necessary to reverse either its current or potential leads in order that the deflection may be noted. In such cases, the algebraic sums must be taken and not the numerical sums. In other words, if one reads + 500 watts and the other - 300 watts, the total power in the circuit will be: $500 - 300 = 200$ watts.

As the load comes on, the readings of the instrument which gave a negative deflection will decrease until they drop to zero, and it will then be necessary to again reverse the potential leads on this wattmeter. Thereafter, the readings of both instruments will be positive, and the numerical sum of the two will be the power consumption of the load.

365. Where No Useful Load Is Available, Generator Loading May Be Accomplished Satisfactorily By A Water Rheostat (Fig. 415).—Where the power developed by the generator, which furnishes the load, can be conveniently employed for a “useful load” as for electric lighting or heating or for motor-driving other machinery it should, obviously, not be wasted. In many plants the power developed by the test generator can be fed into the main bus, thus relieving the other regular generators of part of their load. But where such procedure is not feasible, it is usual to employ a water rheostat as the most convenient means of dissipating the test-load power.

EXPLANATION.—The water rheostat shown in Fig. 415 consists of two iron electrodes, *P* and *S*, one supported from a rope, *R*, which passes over a pulley. The other rests upon the bottom of the barrel. The barrel is filled with water, *W*. Each electrode is connected to a generator lead. The distance between electrodes may be adjusted to vary the resistance offered by the water to the passage of current. Hence the distance between electrodes determines the load on the generator. For voltages below 1000 volts it is usually necessary to add salt to the rheostat water to decrease its resistance sufficiently that a great enough current will flow.

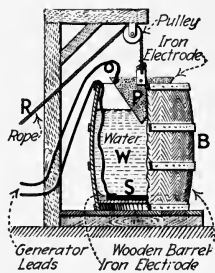

FIG. 415.—Water rheostat for 2-wire systems.

366. In Determining The Water Rate Of Steam Engines, A Steam Condenser Is Often Employed (Fig. 416).—As shown, the steam after being used by the engine is exhausted through

the exhaust pipe, *E*, into the condenser, *C*, where it is condensed. The condensate (condensed steam) runs out through the condensate pipe, *O*, into the weighing tank, *T*. In *T* it is weighed on the scale, *S*. The procedure when using a steam condenser is taken up in following sections. For descriptions of condensers see the author's STEAM POWER PLANT AUXILIARIES AND ACCESSORIES.

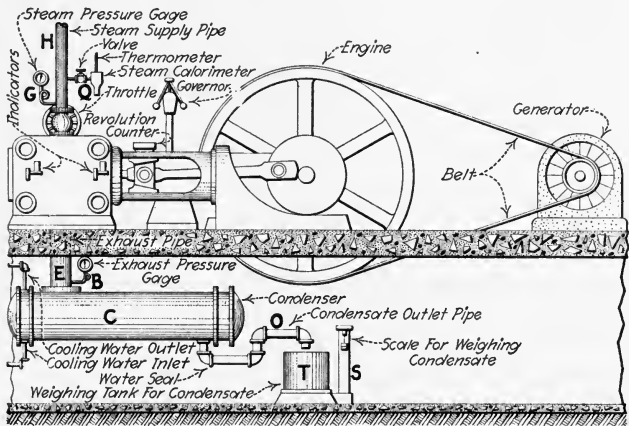

FIG. 416.—Illustrating apparatus used in water-rate test.

367. The Detailed Procedure In Testing An Engine Is usually about as indicated in the paragraphs which follow:

1. Specifically decide the object of the test and keep this in mind, not only during the performance of the test, but also during the preparation of the equipment for conducting the test.

2. Precautions should be taken to insure that the engine and its lubricating system are in condition for continuous running for at least the period of the test without danger of a shut-down for adjustments or repairs. Any interruption of operation during the test period will probably decrease the reliability of the test.

3. The name plate, and other data pertaining to the engine itself and to the equipment and instruments used, should be recorded on the log sheet.

4. All test instruments such as gages, thermometers, tachometers, scales, indicators, reducing motions, etc., should be carefully examined and, in tests where the greatest accuracy is desired, should be calibrated before and after the test (allowances should be made in the test data for any discrepancies in calibration or otherwise that may exist). Great

care should be used in attaching test instruments to the engine as inaccurate readings can be obtained from the most accurate instruments when incorrectly installed.

5. The engine should run under test conditions for a sufficient length of time to allow all conditions, such as temperatures, pressures, etc., to become constant before data readings are taken. This is necessary in order that true test conditions be attained prior to recording test data.

6. The first set of readings may be taken after conditions have become constant. The time and all necessary data should be immediately recorded on a data sheet previously arranged. All readings thereafter should be taken at equal time intervals throughout the test. The necessary time interval will depend on the duration of the test and the constancy of the load (see Sec. 375).

7. After the test has been completed the test apparatus should be carefully cleaned and indicators should be oiled to prevent rusting.

8. Computations for test results should then be made and checked for accuracy. See following sections for methods and formulas used in calculating the test results.

9. Finally, graphs should be plotted on ruled or squared paper to visualize the test results. In mechanical efficiency tests there should be plotted such graphs as "*mechanical efficiency*" against "*brake horse power*," "*speed*" against "*brake horse power*," and "*indicated horse power*" against "*brake horse power*." In the water-rate tests there should be plotted such graphs as "*total pounds of steam consumed per hour*" against "*indicated horse power*" "*water rate*" against "*indicated horse power*," "*boiler pressure*" against "*time*," "*exhaust pressure*" against "*time*," and "*thermal efficiency*" against "*indicated horse power*."

368. In Testing A Simple Engine To Determine Its Mechanical Efficiency, it is merely necessary to ascertain: (1) *Its brake horse power output with a dynamometer or electric generator;* Secs. 353 to 365. (2) *Its indicated horse power with steam engine indicators;* see Div. 3. Then, as explained in Div. 10, the brake horse power (output) divided by the indicated horse power will be the mechanical efficiency. The apparatus is arranged as shown in Fig. 417. It is usually desirable to ascertain the brake and the indicated horse power at a number of different loads so that the efficiencies at these different loads may be determined. Usually the final data are plotted into a graph: Mechanical Efficiency against Load.

NOTE.—IT IS USUALLY ADVANTAGEOUS TO INCREASE OR DECREASE THE BRAKE HORSE POWER LOAD ON THE ENGINE IN EQUAL STEPS when mechanical efficiency tests are being made. The values of brake horse power which are usually taken are $\frac{1}{4}$, $\frac{1}{2}$, $\frac{3}{4}$, 1, and $1\frac{1}{4}$ of the full-load

rating of the engine. This loading permits the plotting of a well-proportioned mechanical-efficiency graph. A minimum of three indicator diagrams should be taken from each end of the cylinder for each load in order that an average mean effective pressure (Sec. 122) may be obtained for each load.

NOTE.—IMMEDIATELY AFTER DIAGRAMS ARE TAKEN, INDICATOR CARDS SHOULD BE MARKED with a symbol designating: (1) *From which*

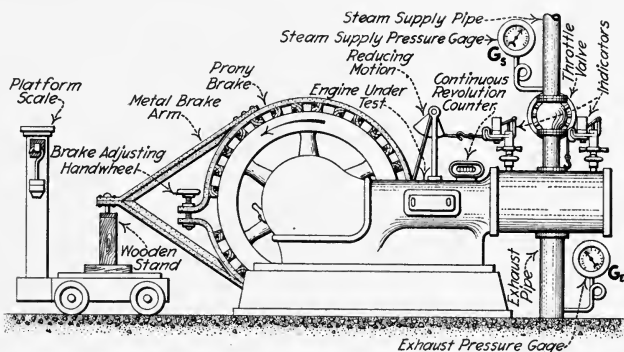

FIG. 417.—Arrangement of apparatus for a mechanical-efficiency test on a simple engine.

end of the cylinder they were taken. (2) *The speed of the engine.* (3) *The brake load when taking the card.* (4) *The time at which the card was taken.* This is necessary to forestall errors when computing the test results.

369. Data Which Should Be Recorded On The Data Sheet In A Mechanical-Efficiency Test are: (1) *Time.* (2) *Brake load.* (3) *Speed.* (4) *Steam pressure.* (5) *Exhaust pressure.* These data

Test No.	Time	Speed	Load on Brake	Steam Pressure	Exhaust Pressure	Remarks

FIG. 418.—Data (log) sheet for mechanical-efficiency engine test.

should be shown on the data sheet. (Fig. 418) even if some of them duplicate data shown on the indicator cards. An accurate record of the steam and exhaust pressures, as indicated by pressure gages, G_s and G_e , Fig. 417, is usually necessary because the engine performance is directly affected by these pressures.

370. In Testing A Simple Engine To Determine Its Water Rate, it is merely necessary to ascertain: (1) *Its indicated horse power* with steam engine indicators (Div. 3). (2) *Its brake*

horse power with a dynamometer or electric generator, Secs. 353 to 365. (3) *The rate at which it uses steam*—by condensing the steam or by measuring the boiler-feed water for a suitable time period. (4) *The condition* (quality or superheat) of its supply steam with a steam calorimeter or a steam thermometer. Then, since the water rate of an engine is usually expressed as the number of pounds of dry steam it uses per indicated (or brake) horse power per hour, the water rate can be readily computed. It is customary to find the water rate of engines at different engine loads (Sec. 368) and then to plot the results into a graph: Water Rate against Load.

EXPLANATION.—Fig. 416 shows the arrangement of equipment for a water-rate test. A steam condenser, *C*, is used in this case for condensing the exhaust steam from the engine in order that the condensed steam may be weighed to determine the water rate of the engine. A steam-pressure gage, *G*, and a steam calorimeter, *Q*, should be placed on the steam-supply pipe, *H*, so that the quality (Sec. 371) of the steam which is used by the engine may be determined. Similarly, a pressure gage, *B*, should be placed between the engine and the condenser to determine the back pressure in the exhaust pipe, *E*.

NOTE.—IN SMALL PLANTS IT IS OFTEN CONVENIENT TO WEIGH, OR METER, THE FEED WATER TO THE BOILER WHICH SUPPLIES STEAM TO THE ENGINE UNDER TEST (Fig. 419) for the determination of its water rate instead of weighing the steam after it has passed through the engine as is shown in Fig. 416. When the boiler-feed method is used, care should be taken to insure that the boiler water level and the boiler steam pressure are the same at the finish of the test as they were at its start.

NOTE.—IF THE SUPPLY STEAM IS SUPERHEATED, a thermometer should be located in the steam-supply pipe adjacent to the throttle valve in addition to the equipment shown in Fig. 416. This thermometer will indicate

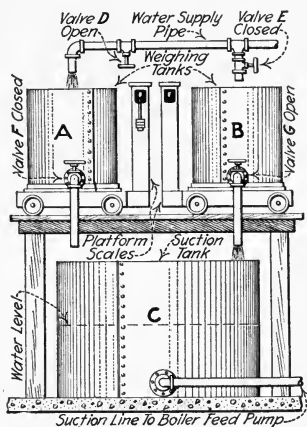

FIG. 419.—Equipment arrangement for weighing boiler feed-water. (Two weighing tanks, *A* and *B*, are mounted on platform scales above a suction tank, *C*, from which water is supplied to the boiler-feed pump. By means of the valve arrangement shown, one tank, *A*, can be filled with water and weighed while the other tank, *B*, discharges its water into the suction tank, *C*. The water level in tank, *C*, should be at the same height at the end of the test as it was at the beginning of the test.)

the temperature of the supply steam. A knowledge of this temperature is necessary to determine the amount of superheat (see Sec. 426) of the steam.

371. Data Which Should Be Recorded On The Data Sheet In A Water-Rate Test are the same as for a mechanical-efficiency test with the addition of: (1) The *temperature of the steam in the steam calorimeter*, if the supply steam is wet. (2) The *temperature of the supply steam*, if it is superheated. (3) The *weights of steam used by the engine for each load*, as the load is usually applied in increments as explained in Sec. 368. The quality and pressure of the supply steam (or the temperature of the supply steam, if superheated) and the pressure of the exhaust steam are important in water-rate tests as the steam consumption of engines is directly affected by these quantities.

NOTE.—STEAM QUALITY AND ITS DETERMINATION are discussed in the author's PRACTICAL HEAT. To find the quality of steam with a throttling calorimeter substitute in the following formula, the derivation of which is given in PRACTICAL HEAT:

$$(53) \quad x_p = \frac{100[H_{d2} + C_m(T_{f2} - T_{f3}) - H_l]}{H_v} \quad (\text{per cent.})$$

Wherein: x_p = the *quality of the steam* in the engine supply pipe, in per cent. H_{d2} = the *total heat of dry saturated steam* at the pressure existing in the calorimeter, in British thermal units per pound. T_{f2} = the temperature in the calorimeter, in degrees Fahrenheit. T_{f3} = the temperature of saturated steam at the pressure, which is usually assumed to be the barometric pressure, existing in the calorimeter, in degrees Fahrenheit. H_l = the *heat of the liquid* at the pressure existing in the engine supply pipe, in British thermal units per pound. H_v = the *latent heat of steam* at the pressure existing in the steam supply pipe, in British thermal units per pound. C_m = the *mean specific heat of superheated steam*, in British thermal units per pound per degree Fahrenheit rise in temperature, and which may be considered as equal to 0.46.

All of the above properties of steam can be found in any standard steam table.

CAUTION.—All steam tables are arranged for absolute pressures and not for the gage pressures as indicated by gages. To obtain the absolute pressure in any case, it is only necessary to add the atmospheric pressure (Barometric pressure), expressed in pounds per square inch, to the pressure indicated by the gage. See author's PRACTICAL HEAT for an explanation of this situation.

EXAMPLE.—In Fig. 420, if the barometric pressure is 14.7 lb. per sq in., the temperature of the steam in the throttling calorimeter 270 deg. Fahr., and the steam pressure is 150 lb. gage (164.7 lb. abs.), what is the quality of the steam supplied to the engine? SOLUTION.—Substituting in For. (53):

$$x_p = 100[H_{d2} + C_m(T_{f2} - T_{f3}) - H_i]/H_v = \\ 100[1150.4 + 0.46(270 - 212) - 338] \div 856.8 = 98 \text{ per cent.} \\ \text{The per cent. of moisture in the steam} = 100 - 98 = 2 \text{ per cent.}$$

372. In A Water-Rate Test, It Is Necessary To Express The Weight Of Wet Steam Used By An Engine In Terms Of Weight Of Dry Steam Used as all water rates are expressed in pounds of dry steam per indicated—or brake—horse power per hour. If the engine being tested is taking wet steam (steam of less than 100 per cent. quality), the weight of dry steam used can be found by substituting in the formula:

$$(54) \quad W_{sd} = x_d W_{sw} \quad (\text{lb. of dry steam})$$

Wherein: W_{sd} = the weight of dry steam used, in pounds. x_d = the quality of the steam, expressed decimally. W_{sw} = the weight of wet steam used.

373. The Water Rate Of An Engine Can Be Calculated by the following formula if the water rate is to be based on indicated horse power:

$$(55) \quad W_{sdi} = \frac{W_{sd}}{P_{ihp} \times t_h} \quad (\text{lb. dry steam per i.h.p. hr.})$$

or if the water rate is to be based on brake horse power:

$$(56) \quad W_{sdb} = \frac{W_{sd}}{P_{bhp} \times t_h} \quad (\text{lb. dry steam per b.h.p. hr.})$$

Wherein: W_{sdi} = the water rate based on indicated horse power, in pounds of dry steam per indicated horse power per hour. W_{sdb} = the water rate based on brake horse power, in pounds of dry steam per brake horse power per hour. W_{sd} = the total weight, in pounds, of dry steam consumed during the time t_h , in hours. P_{ihp} = the average indicated horse power developed during the time period t_h . P_{bhp} = the average brake horse power developed during the time period t_h .

EXAMPLE.—In Fig. 420 if the engine develops 85 i.h.p. and 2550 lb. of steam are used per hour, what is the water rate of the engine in pounds

of dry steam per indicated horse power per hour? SOLUTION.—In the example under Sec. 371, it was found that the quality of the steam was 98 per cent. or 0.98. From For. (54), the total weight of dry steam used = $W_{sd} = x_d W_{sw} = 0.98 \times 2550 = 2499$ lb. From For. (55), the water rate = $W_{sdi} = W_{sd} / P_{ihp} \times t_h = 2499 \div (85 \times 1) = 29.4$ lb. of dry steam per i.h.p. hr.

NOTE.—THE WATER RATE OF AN ENGINE CAN BE CALCULATED APPROXIMATELY BY MEANS OF INDICATOR CARDS (see Div. 3). This method is often used to check other methods of determining the water rate.

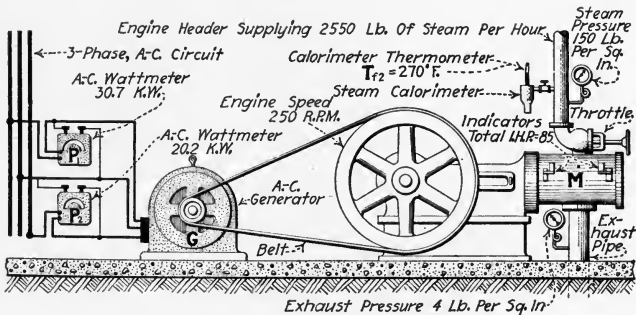

FIG. 420.—Illustrating calculation of water rate and thermal efficiency of engine, *M*, using generator, *G*.

374. To Determine The Thermal Efficiency Of An Engine, it is necessary to know: (1) *The rate at which work is done by an engine* (its power output). (2) *The rate at which heat is furnished to the engine* (its power input.) Both of these are reduced to British thermal units per hour per horse power. Then, as explained in Div. 10, if the value for (1) is divided by that for (2) the thermal efficiency will be the result. The power output is found by measuring the indicated horse power (Div. 3). Sometimes, brake horse power is considered as the power output. The brake horse power is measured with a dynamometer or electric generator (Secs. 353 to 365). The power input is found by ascertaining the water rate of the engine and the heat consumed per pound of steam used (Div. 10). Hence it is obvious that the values necessary for the computation of the thermal efficiency are obtained from the same test data as are required in a water-rate test (Secs. 370 to 373).

NOTE.—THE THERMAL EFFICIENCY CAN ALSO BE CALCULATED BY FOLLOWING THE TEST CODE OF THE AMERICAN SOCIETY OF MECHANICAL ENGINEERS which is given in a condensed form in Sec. 381. The TEST CODE is a conveniently arranged form consisting of the logical and successive steps to be taken in the calculation of engine-test results.

EXAMPLE.—If the back pressure (exhaust pressure) in Fig. 420 is 4 lb. gage (18.7 lb. abs.), what is the thermal efficiency of the engine based on indicated horse power? SOLUTION.—By For. (32) in Sec. 317, $H_{t1} = x_d H_v + H_l$. By For. (31): $E_{dti} = 2545/W_{si}(H_{t1} - H_{t2})$. Now, from Fig. 420: $W_{si} = 2550 \div 85 = 30$ lb. per i.h.p. hr. Therefore, with the results found in the example under Sec. 371 and taking values from a standard steam table, the thermal efficiency = $E_{dti} = 2545/W_{si}[(x_d H_v + H_l) - H_{t2}] = 2545 \div 30[(0.98 \times 856.8 + 338) - 192.6] = 0.0854 = 8.54$ per cent. = *thermal efficiency based on indicated horse power.*

EXAMPLE.—If the supply steam in the preceding example were superheated instead of wet and if the temperature of the steam at the throttle was 435.4 deg. fahr., what would be the thermal efficiency of the engine based on indicated horse power? SOLUTION.—From For. (31), the thermal efficiency = $E_{dti} = 2545/W_{si}(H_t - H_{t2}) = 2545 \div [30(1,235.9 - 192.6)] = 2545 \div 31,299 = 0.0814 = 8.14$ per cent. = *thermal efficiency based on indicated horse power.*

375. The Duration Of A Test Depends Upon The Type Of Test Being Made.—For a mechanical-efficiency test, sufficient time should be allowed for five or six load increments to be applied. For water-rate tests the TEST CODE of the American Society of Mechanical Engineers specifies:

“A test for steam or heat consumption, with substantially constant load, should be continued for such time as may be necessary to obtain a number of successive hourly readings, during which the results are reasonably uniform. For a test involving the measurement of feed-water for this purpose, five hours duration is sufficient. Where a surface condenser is used, and the measurement is that of the water discharged . . . , the duration may be somewhat shorter. In this case successive half-hourly records may be compared and the time correspondingly reduced. When the load varies widely at different times of the day, the duration should be such as to cover the entire period of variation.”

376. An Acceptance Test Is A Water-Rate Test on a new engine conducted under the observation of both the purchaser and the seller to determine whether the economy, or pounds of steam per indicated horse power hour (or brake horse power hour), for different loads is as economical as was specified in the purchasing contract (see Sec. 456).

377. In Testing Compound Engines the same procedure can be followed as described in Sec. 367. In such a test, indicator cards must be taken from both the high- and low-pressure cylinders (see Div. 8). The total indicated horse power of the engine will be the sum of the indicated horse power of the high- and of the low-pressure cylinders. The temperature and pressure of the steam in the receiver should be recorded with the other data. An arrangement of apparatus for testing a compound engine is shown in Fig. 421.

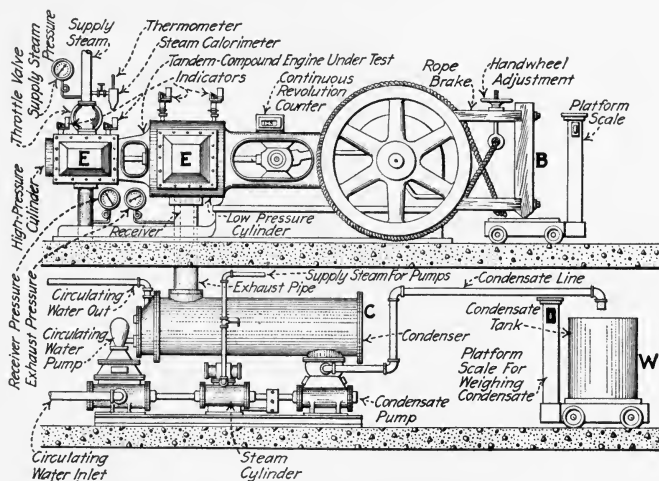

FIG. 421.—Arrangement of equipment for determining the water rate of a tandem-compound engine. (Horse power is measured with brake *B*. Steam used by engine, *E*, is condensed in *C* and the condensate weighed in *W*.)

378. In Testing High-Speed Engines care should be used to determine the speed accurately. The indicators and reducing motion should be examined for lost motion as this may cause a noticeable deformation of the indicator cards. Some simple method (see the note under Sec. 101) should be provided for connecting and disconnecting the indicator cord from the reducing motion, as this is often difficult to do on high-speed engines. The brake load should be applied carefully as a slight inaccuracy in loading may cause a large error in power.

379. The Clearance Volume Is Often Determined In Engine Testing especially to enable the plotting of the theoretical

expansion curve (Sec. 108). The clearance volume may be found by setting the engine carefully on dead center (Sec. 153) and filling the clearance volume with water from a previously weighed container. The difference in weight of the container before and after filling the clearance space will give the weight of the water in the clearance space. From this, the volume of water in, or the volume of, the clearance space may be calculated.

NOTE.—ALLOWANCE SHOULD BE MADE FOR LEAKY PISTONS AND VALVES WHEN THE CLEARANCE IS BEING DETERMINED by this method. Data may be obtained (Fig. 422) for the necessary correction in this way:

(1) Observe the time and quantity of water required to fill the clearance space at a uniform rate. (2) Note the quantity of water required to keep the clearance space completely filled for any convenient length of time. (3) The clearance volume may then be found by substituting in the following formula:

$$(57) \quad V_i = V_{i1} - \frac{t_{s1} V_{i2}}{2t_{s2}} \quad (\text{cu. in.})$$

Wherein: V_i = the clearance volume, in cubic inches. V_{i1} = the volume of water, in cubic inches, originally necessary to fill the clearance space at a uniform rate. t_{s1} = the time, in seconds, originally required to fill the clearance space with the quantity of water V_{i1} . V_{i2} = the volume of water, in cubic inches, necessary to keep the clearance space completely filled. t_{s2} = the time, in seconds, required for introducing the volume of water V_{i2} .

DERIVATION.—If no leakage occurred, V_i , the clearance volume, in cubic inches, would be equal to V_{i1} , which is the volume of water, in cubic inches, originally necessary to fill the clearance space at a uniform rate. But if there is leakage, then the volume of water lost through leakage must be determined. It is apparent that during the time t_{s1} , which elapses while the clearance space is filled with V_{i1} , the rate of leakage around the piston begins at zero and finally attains a maximum as the water level reaches the top of and fills the clearance space. It follows that the average rate of leakage during the t_{s1} seconds is (very nearly) one-half of the maximum rate. This maximum rate is found after the clearance volume is full by introducing V_{i2} . The maximum rate is

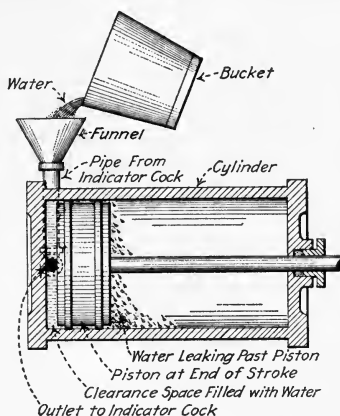

FIG. 422.—Method of determining clearance volume in an engine cylinder.

$V_{i2} \div t_{s2}$. The average rate during t_{s1} is therefore one-half the maximum $= V_{i2}/2t_{s2}$. The time required to introduce V_{i1} was t_{s1} . Therefore: since *total leakage during the time = the rate \times the time*, it follows that,

$$(58) \quad \text{leakage} = \frac{V_{i2}}{2t_{s2}} \times t_{s1} \quad (\text{cu. in.})$$

which must be subtracted from V_{i1} to find the net volume of the clearance space, V_i . Therefore, by subtraction:

$$(59) \quad V_i = V_{i1} - \frac{t_{s1}V_{i2}}{2t_{s2}}$$

which is the same as For. (57).

EXAMPLE.—If it takes 120 sec. to fill the clearance space of an engine having a leaky piston with 30 cu. in. of water, and it takes 10 cu. in. of water to keep the clearance space completely filled for 200 sec., what is the true clearance volume? SOLUTION.—By For. (57): *the true clearance volume* $= V_i = V_{i1} - t_{s1}V_{i2}/2t_{s2} = 30 - [(120 \times 10) \div (2 \times 200)] = 30 - [1200 \div 400] = 30 - 3 = 27 \text{ cu. in.}$

380. It Sometimes Facilitates The Computation Of Test Results If The Engine And Brake Constants Are Calculated.

These constants are the numerical results of certain factors which will occur in test computations several times and if the constants are calculated at the start of the test computations, some time will be saved. The engine constants are obtained from For. (13) of Sec. 121 and will not be discussed here. The brake constant is obtained from For. (41), Sec. 357, which is

$$(60) \quad \mathbf{P}_{bh_p} = \frac{2\pi L_f N(\mathbf{W} - \mathbf{W}_1)}{33,000} \quad (\text{b.h.p.})$$

Wherein: $2: \pi: 33,000$; and L_f (effective length of brake arm in feet) are all constant values for each test. The brake constant then is:

$$(61) \quad k_b = \frac{2\pi L_f}{33,000} \quad (\text{brake constant})$$

The brake horse power formula, For. (41), then becomes:

$$(62) \quad \mathbf{P}_{bh_p} = k_b N(\mathbf{W} - \mathbf{W}_1) \quad (\text{b.h.p.})$$

Wherein: \mathbf{P}_{bh_p} = the brake horse power developed. k_b = the brake constant. N = the speed of the engine, in revolutions per minute. \mathbf{W} = the gross load on the scale, in pounds. \mathbf{W}_1 = the tare-weight of the brake, in pounds, as explained in Sec. 356.

EXAMPLE.—If the effective brake-arm length for an engine is 5 ft., what is the brake constant? SOLUTION.—From For. (61) the *brake constant* = $k_b = 2\pi L_f/33,000 = (2 \times 3.14 \times 5) \div 33,000 = 0.000,953 =$ the *brake constant*.

EXAMPLE.—If, for the above engine, a 600-lb. load is indicated by the platform scale, the tare-weight of the brake is 50 lb., and the speed of the engine is 180 r.p.m., what brake horse power is developed by the engine? SOLUTION.—From For. (62), the brake horse power = $P_{bhp} = k_b N (W - W_1) = 0.000,953 \times 180(600 - 50) = 94.3$ *b.h.p.*

381. An Outline Of The American Society Of Mechanical Engineers, Steam-Engine Test Code which will standardize procedure and will promote accuracy and rapidity of calculation follows:

DATA AND RESULTS OF STEAM-ENGINE TESTS

CODE OF 1915

1. Test of.....engine located at.....
 To determine.....
 Test conducted by.....

DIMENSIONS, ETC.

2. Type of engine.....
3. Rated power of engine.....
 (a) Name of builders.....
 (b) Kind of valves.....
 (c) Type of governor.....
4. Diameter of cylinder.....in.
5. Stroke of piston.....ft.

DATE AND DURATION

6. Date.....
7. Duration.....hr.

AVERAGE PRESSURES AND TEMPERATURES

8. Pressure in steam pipe near throttle, by gage.....lb. per sq. in.
9. Barometric pressure.....in. of mercury.
 (a) Pressure at boiler, by gage.....lb. per sq. in.
10. Pressure in receiver, by gage.....lb. per sq. in.
11. Pressure in exhaust pipe near engine, by gage.....lb. per sq. in.
12. Temperature of steam near throttle.....deg.
13. Temperature of steam in exhaust pipe near engine.....deg.

QUALITY OF STEAM

14. Percentage of moisture in steam near throttle or number of degrees of superheat.....per cent. or deg.

TOTAL QUANTITIES

15. Total water fed to boiler.....lb.
 16. Total condensed steam from surface condenser (corrected for condenser leakage).....lb.
 17. Total dry steam consumed (Item 15 or 16 less moisture in steam). .lb.

HOURLY QUANTITIES

18. Total water fed to boilers or drawn from surface condenser per hour.....lb.
 19. Total dry steam consumed for all purposes per hour (Item 17 ÷ Item 7).....lb.
 20. Dry steam consumed per hour for all purposes foreign to the main engine.....lb.
 21. Dry steam consumed by engine per hour (Item 19 - Item 20)....lb.

HOURLY HEAT DATA

22. Heat units consumed per hour [Item 21 × (total heat of steam per pound at pressure of Item 8 minus heat in 1 lb. of water at temperature of Item 13)].....B.t.u.

INDICATOR DIAGRAMS

23. Commercial cut-off in per cent. of stroke.....per cent.
 24. Initial pressure above atmosphere.....lb. per sq. in.
 25. Back pressure at lowest point above or below atmosphere.....
 lb. per sq. in.

SPEED

26. Revolutions per minute.....r.p.m.
 (a) Variation of speed between no load and full load.....per cent.

POWER

27. Indicated horse power developed.....i.h.p.
 28. Brake horse power.....b.h.p.
 29. Friction of engine (Item 27 - Item 28).....h.p.

ECONOMY RESULTS

30. Dry steam consumed by engine per i.h.p. hr.....lb.
 31. Dry steam consumed by engine per b.h.p. hr.....lb.
 32. Heat units consumed by engine per i.h.p. hr. (Item 22 ÷ Item 27).....B.t.u.
 33. Heat units consumed by engine per b.h.p. hr. (Item 22 ÷ Item 28).....B.t.u.

EFFICIENCY RESULTS

34. Thermal efficiency of engine referred to i.h.p. ($2546.5 \div$ Item 32) × 100.....per cent.
 35. Thermal efficiency of engine referred to b.h.p. ($2546.5 \div$ Item 33) × 100.....per cent.

SAMPLE DIAGRAMS

36. Sample diagrams from each cylinder.....

“NOTE.—For an engine driving an electric generator the form should be enlarged to include the electrical data, embracing the average voltage, number of amperes in each phase, number of watts, number of watt hours, average power factor, etc. and the economy results based on the electric output embracing the heat units and steam consumed per electric h.p. hr. and per kw. hr. together with the efficiency of the generator.”

EDITOR'S NOTE.—THE THERMAL EFFICIENCY AS FOUND IN THE ABOVE TEST CODE WILL DIFFER BY A SMALL PERCENTAGE FROM THE THERMAL EFFICIENCY AS FOUND BY FOR. (31), SEC. 317. This is due to the fact that in Item 22 of the above code the total heat units consumed by an engine is considered as: $x_d W_{si}(H_{t1} - H_{t2})$, while from Fors. (31) and (32), the total heat consumed by an engine = $W_{si}(x_d H_v + H_i) - H_{t2}$. Wherein: W_{si} = the weight of wet steam consumed by the engine per indicated horse power hour. x_d = the quality of the supply steam expressed decimally. H_{t1} = the total heat in 1 lb. of steam at the supply pressure, in B.t.u. H_{t2} = the heat in 1 lb. of water at exhaust pressure, in B.t.u. H_i = the heat in 1 lb. of water at the supply pressure, in B.t.u. H_v = the latent heat of vaporization of 1 lb. of steam at the supply pressure, in B.t.u. The difference in thermal efficiencies, as found by these two different methods, will generally not amount to more than one-half of 1 per cent.

QUESTIONS ON DIVISION 12

1. What are the purposes of testing steam engines?
2. What is meant by the term *brake horse power*?
3. What is meant by the term *total indicated horse power*?
4. What is meant by the term *friction horse power*?
5. What is the *mechanical efficiency* of an engine?
6. What is the difference between a revolution counter and a tachometer?
7. What are the two general classes of load-measuring apparatus?
8. What is a Prony brake? Draw a sketch and describe one.
9. What is the principle of operation of a fluid-friction-type brake?
10. What is meant by the term *effective length of brake arm*? Illustrate with a sketch.
11. What is the effective length of brake arm for a rope brake?
12. What is the *tare-weight* of a brake and how is it determined?
13. How may the electrical loading of engines for testing be accomplished?
14. How is the power output of a three-phase alternating-current generator determined?
15. Illustrate with a sketch how the wattmeter connections should be made for determining the power output of a three-phase, three-wire, alternating-current generator.
16. What is the *water rate* of a steam engine?
17. How are steam engine water rates usually expressed?
18. What apparatus is necessary in a water-rate test? Draw a sketch and explain.
19. When and how is the steam calorimeter used in engine testing?
20. What is the general procedure in testing an engine?
21. How should the load be applied in engine testing?
22. What data are necessary in a water-rate test of a compound engine?
23. What precautions are necessary in testing high-speed engines?
24. How may the clearance volume of an engine be determined?

PROBLEMS ON DIVISION 12

1. An engine develops 120 brake horse power on an indicated horse power of 133. What is the mechanical efficiency? What is the friction horse power?
2. What is the brake horse power developed by an engine (Fig. 423) at a speed of 220 r.p.m. with a net weight of 250 lb. on the platform scale, if the effective length of the brake arm is 63 in.?
3. What is the brake constant for a $\frac{3}{4}$ -in. rope brake (Fig. 424) on a 6-ft. diameter flywheel?
4. An engine uses 5000 lb. of steam (97 per cent. quality) per hour when developing 200 h.p. (indicated). What is the water rate of the engine in pounds of dry steam per indicated horse power per hour?

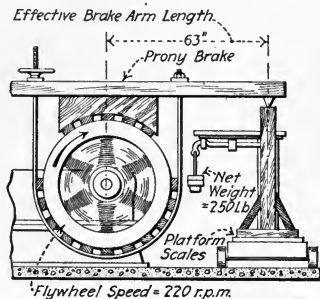

FIG. 423.—What is the brake horse power?

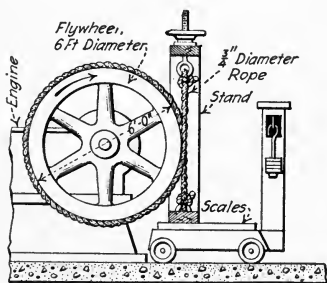

FIG. 424.—What is the brake constant?

5. The engine of Fig. 420 uses 2550 lb. of steam per hour. What is its water rate in pounds of dry steam per brake horse power per hour, if the wattmeters read 20.2 kw. and 30.7 kw. as illustrated and the generator efficiency at this load is 90 per cent.? What is the thermal efficiency based on brake horse power?
6. A certain engine develops a total indicated horse power of 200 with steam pressure at 200 lb. per sq. in. gage and exhaust pressure at 8 lb. per sq. in. gage. If the quality of the supply steam is 99 per cent. and the mechanical efficiency of the engine is 90 per cent. at this load, what is the thermal efficiency of the engine based on brake horse power when the steam consumption is 42,000 lb. in a 10-hr shift? (Assume barometric pressure is 14.7 lb. per sq. in.).

DIVISION 13

RECIPROCATING-ENGINE MANAGEMENT, OPERATION AND REPAIR

382. The Purposes Of Proper Engine Management are: (1) *Reliability*. (2) *Efficiency*. Reliability is secured by anticipating all common sources of trouble, such as knocks, hot bearings, clogged condenser passages and all accidents by careful attention while the engine is running; and postponing the repairs, adjustment and overhauling which will eventually be necessary until a shut-down is convenient. A definite upper limit which the efficiency of an engine cannot exceed is fixed by its design; but the efficiency may be prevented from becoming unduly low by avoiding excessive leakage and friction, and by correct adjustment. A skillful operator can, by the sound, detect most troubles in an engine room with which he is familiar. By early detecting and correcting trouble and by regular inspection, an engine may be kept in perfect condition with a minimum of effort.

383. An Important Duty Of An Engineer Is To Become Thoroughly Familiar With The Equipment Which He Is To Operate.—The first day which an engineer spends in a new plant or one for which he is to assume responsibility usually provides the best opportunity for a general inspection. Among the parts which it is well to include in such an inspection are:

1. *Cylinders*. If the cylinder heads have been removed (or if there is time for removing them) see that the piston-rod nuts and bolts of the follower-plate, *F* (Fig. 425), are tight and well secured. A set screw or lock nut (Fig. 426) is recommended for the piston-rod nuts. Note the condition of the cylinder walls, whether they are scored or pitted. Note also the linear clearance between the piston and cylinder head at the end of the stroke, and mark this distance on the guides for reference. While the cylinder head is off, the amount of piston and valve leakage

may be noted by admitting a little steam to the crank end at crank-end dead center and noting the escape of steam. Use a good gasket coated with graphite in closing the cylinder. In replacing the cylinder head, be sure that the cylinder walls are free from grit, are well lubricated, and that *no tools or other obstructions remain in the cylinder.*

2. *Valves.* If valve chest covers are off (or if there is time for removing

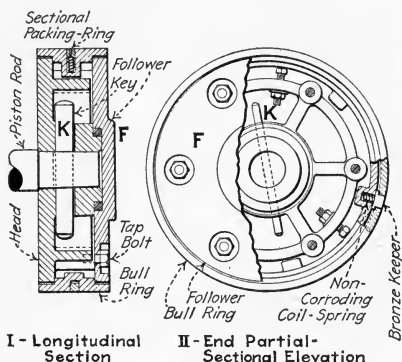

FIG. 425.—Piston construction used in the St. Louis Corliss engine. A taper cotter, *K*, is used in place of the usual piston-rod nut. (St. Louis Iron and Machine Works).

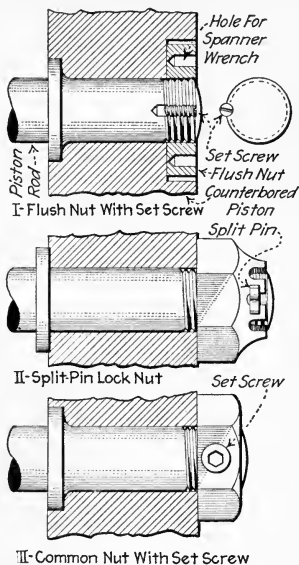

FIG. 426.—Showing methods of locking piston-rod nuts.

them) note the condition of the valves. Measure the laps (Sec. 143) for future adjustment and if feasible make templets as described in Sec. 157. Also note the valve action by turning the engine over by hand (if the engine is small) with the cover off. Make sure, in replacing the covers, that the valve chest is clean, the rubbing surfaces well lubricated, and that the gaskets used for the covers are in good condition. Pump valves, if found in poor condition, should be refaced or replaced.

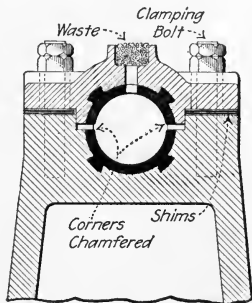

FIG. 427.—Simple split bearing.

3. *Flywheel.* Note if the dead centers are marked (Sec. 153) on the flywheel rim for valve setting. If the engine is small, turn it over by hand to see if there is undue friction in its bearings.

4. *Bearings.* Any bearings or boxes which are disassembled should be examined, cleaned if necessary and adjusted. The condition of all bearings and their oil passages should be ascertained as far as possible.

Clean out oil holes, put in fresh oil and fill with waste (Fig. 427) if exposed.

5. *Stuffing boxes.* If the packing appears to be in good condition, oil it and screw up to a reasonable compression. If not, repack (Sec. 415).

6. *Auxiliaries.* The engineer is usually in charge of some or all of the power plant auxiliaries. For care of these, see the author's *STEAM POWER PLANT AUXILIARIES AND ACCESSORIES*.

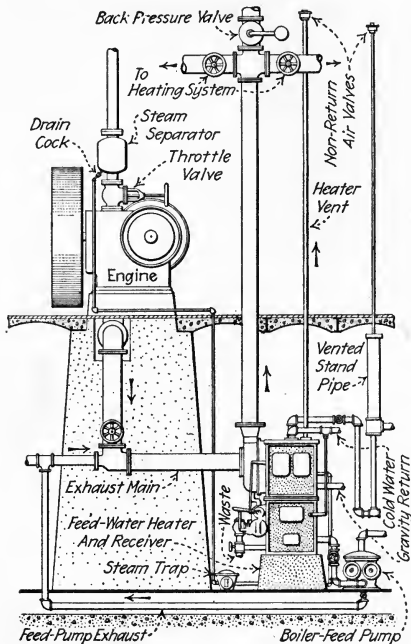

FIG. 428.—Auxiliary piping and equipment used in connection with non-condensing steam engine.

7. *Pumps.* These should be given the same sort of inspection as the engine as far as it is applicable; see *STEAM POWER PLANT AUXILIARIES AND ACCESSORIES*.

8. *Condensers.* If the steam-space manhole cover or water-space cover of a surface condenser is removed, note the condition of the tubes inside and out. If the grease is excessive on the outside, the steam space should be filled with water and boiled out. The water in the steam space will issue from any split tubes or leaky tube glands. These should be renewed, repacked or tightened as required. The condition of the sprays and passages of a jet condenser should be ascertained if possible. See the author's *STEAM POWER PLANT AUXILIARIES AND ACCESSORIES* for further information relating to condenser operation and maintenance.

9. *Piping.* Trace out all piping connected with the engine (Figs. 428 and 441) and the auxiliaries. If difficulty is experienced in keeping the piping in mind, sketch diagrams (Fig. 429) may be used, or instead the different systems, *i.e.*, city water, low-pressure steam, condenser water, etc., may be marked with occasional stripes of different colors. The locations of all valves should be carefully noted. Piping that is rusting rapidly should be cleaned, painted and protected from water if possible. Exposed steam or hot-water piping should be lagged. Exhaust lines to condensers (Fig. 430) and atmosphere and valves, *G*, for changing from condensing to non-condensing operation should be examined.

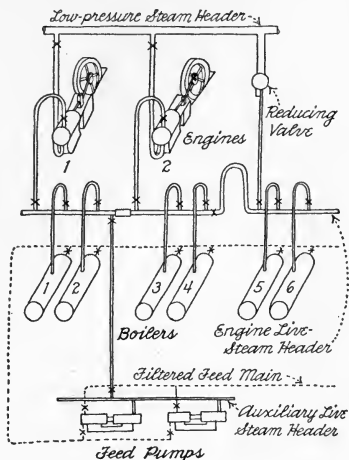

Fig. 429.—Sketch diagram of piping.

10. *Drains.* Drains both on the engine and piping and the traps used in connection with them should be noted and tested to make sure that they are clear.

11. *Instruments.* The pet cocks on gage glasses should be tested to see if they are clear. It should be noted whether the pressure gages

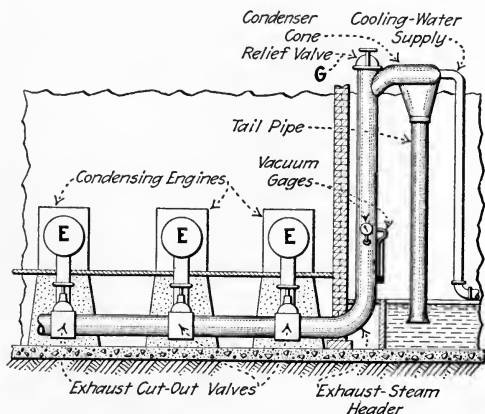

Fig. 430.—Showing how several engines, *E*, may be operated condensing with one barometric condenser.

and thermometers work properly. If time permits, they should be tested or calibrated.

12. *Tools.* See that tools for oiling and for simple repairs and adjustments are in place.

13. *Supplies.* See that cylinder and engine oil and grease, gasket stock, piston and candle-wicking packing, waste, red lead, graphite, and other supplies are on hand.

384. All Steam Engines Should Be Warmed And Drained Before Starting.—The pipe, *A* (Fig. 431), leading to the engine should be warmed and drained before the throttle, *C*, is given a large opening. This is to insure that the steam which condenses in warming the pipe will not run into the engine. To

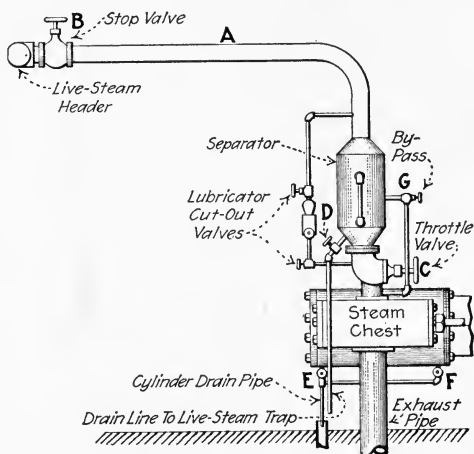

FIG. 431.—Steam piping for a simple engine.

do this, the drain valve, *D*, should be opened and stop valve, *B*, opened a very little. While the pipe, *A*, is being warmed, the drain valves, *E* and *F*, should be opened and the throttle, *C*, loosened on its seat to prevent sticking. After the pipe, *A*, is warmed, the valve, *B*, may be opened wide; but neither *B* nor *C* should be opened suddenly since a sudden large flow of steam through a pipe is likely to draw water from the boiler which may wreck the piping. Then either the throttle, *C*, or by-pass valve, *G*, may be opened slightly to warm up the engine.

NOTE.—LARGE ENGINES MUST BE WARMED UP SLOWLY. In general, the warming up for engines of capacities exceeding 100 h.p. should commence 15 or 20 min. before the engine is to be started. If the fires

in the boilers are just being started when it is desired to warm the engine, the stop and throttle valves may both be opened so that warm air from the boiler will pass through the cylinders. But the stop and throttle valves should both be nearly closed as soon as the boiler begins to generate steam.

NOTE.—INDEPENDENT OR CENTRAL LUBRICATORS, *Y* (Fig. 432), FOR THE GUIDES, CRANK PIN OR OTHER BEARINGS should be started just before the engine is started. The cylinder lubricator, *X* (Fig. 432), should be started as soon as the engine begins to turn over.

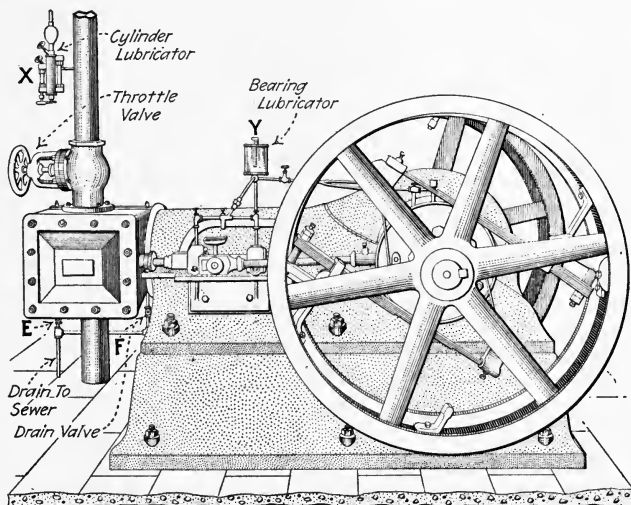

FIG. 432.—Simple slide-valve automatic engine. (Erie Engine Works.)

NOTE.—THE TYPE OF GOVERNOR MAKES NO DIFFERENCE IN STARTING AND STOPPING SLIDE-VALVE ENGINES because the governor—whether throttling or automatic—is not in action while the engine is starting or stopping. It comes into play only when the engine is running near the speed for which the governor is set. The methods of handling Corliss-engine governors when starting or stopping the engine are described in Sec. 392.

385. A Non-Condensing Slide-Valve Engine May Be Started as follows: The drain cocks, *E* and *F* (Fig. 431), are assumed to be open, the stop valve open, the throttle just off its seat, the lubricators for the bearings started and the engine warmed. Unless there are by-pass warming pipes, *MN* (Fig. 433), to both ends of the cylinder, the engine should, in warming, be rotated or rocked back and forth to

allow steam to enter both ends of the cylinder. The engine is then preferably placed about 20 to 30 deg. past dead center. It is started by quickly opening the throttle enough to carry the engine past its first dead center. After the first dead center has been passed, it may be necessary to again partially close the throttle to prevent the engine's speed from becoming excessive. The speed should be kept low at first and be gradually brought up to running speed by further opening the throttle valve. The lubricator, *X* (Fig. 432), should now be started. As soon as the drain cocks, *EF* (Fig. 431), blow dry steam, they may be closed.

386. The Engineer Should Feel An Engine's Bearings After It Has Been Running A Short Time, say in from 15 min. to 1 hr., depending on the load on the engine. They should not

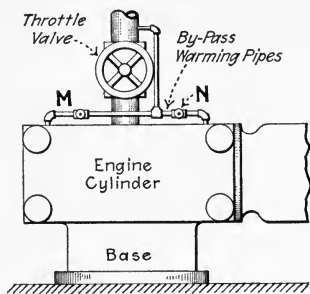

FIG. 433.—Showing by-pass to both ends of an engine cylinder to facilitate warming.

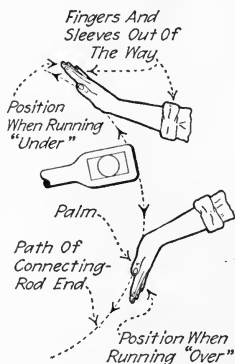

FIG. 434.—Showing method of feeling crank-pin bearing.

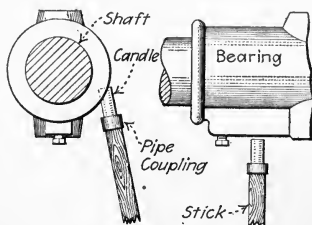

FIG. 435.—Feeler for detecting heating of inaccessible bearings. (The behavior of the candle when pushed against a hot bearing may be tested by pushing it against a feed-water or low-pressure steam pipe.)

be more than slightly warm. The crank-pin bearing may be felt with the palm of the hand if the path of the moving connecting rod end is carefully noted (Fig. 434), but care is necessary

to avoid being caught or hit by a high-speed rod. If there seems to be too much oil flowing to any of the bearings, the supply may be cut down. If any bearing shows a tendency to heat up to such a temperature that the human hand cannot be held on it, it should be given plenty of oil. About 130 deg. fahr. is a conservative maximum allowable bearing temperature. For treatment of hot bearings, see Secs. 412 and 413.

NOTE.—Where bearings are inaccessible, a feeler (Fig. 435) may be used. A little practice will enable the operator to judge the temperature of an object against which the candle of the feeler is pushed.

387. To Stop A Slide-Valve Non-Condensing Engine, it is only necessary to close the throttle valve. If the engine is to remain idle for some time, the main stop valve should be closed and all the oil feeds shut off. The throttle should be left loosely on its seat so that there will be no trouble in opening it again. If the stop is for a few minutes, the drains, *E* and *F* (Fig. 431), should be opened and either the throttle or by-pass valves opened a little to keep the engine warm and drained. If the engine is a hoisting engine operated by signals from some other point, the engineer should stand by for further signals. If the signal to start again is expected in a few seconds, nothing but the throttle and perhaps the reversing gear need ordinarily be touched. If the engine is to be laid up (see Sec. 398) for some time, the drains should be opened and be left open until the engine is started again.

NOTE.—NON-RELEASING CORLISS-VALVE ENGINES MAY BE STARTED AND STOPPED IN THE SAME WAY AS ARE SLIDE-VALVE ENGINES. There is less trouble in draining the cylinders of Corliiss-valve engines because the exhaust valves of such engines are so located that the condensed steam drains through them. These engines are therefore not always provided with cylinder drains. In starting the engine, first open the throttle valve sufficiently to permit the engine to "warm up." Then close the throttle and turn the engine over by hand to allow any condensation to flow from the cylinder. Now open the throttle just enough to allow the engine to run very slowly until it is thoroughly warm. Then by further opening the throttle valve the engine may be slowly brought up to normal speed.

388. A Slide-Valve Condensing Engine Which Has Separately Operated Condenser Pumps Should Be Started After

The Pumps Are Started.—Where the condenser pumps are driven mechanically from the main engine they start simultaneously with it. In starting a slide-valve condensing engine, start the circulating and air pumps of the condenser according to directions for starting non-condensing engines (Sec. 385). When there is an average flow of cooling water through the condenser and a few inches of vacuum are produced in it, the engine may be started exactly as described for non-condensing operation. When the cylinder drain valves are open, there will be little vacuum due to the drain valves admitting air. The engine may, of course, be warming up while the condenser is being started. After the engine has been running condensing long enough to give a constant temperature in the condenser, the circulating and air pumps may be adjusted to give the desired condenser pressure and condensate temperature. The condensate temperature should ordinarily be about 100 to 120 deg. fahr. The condenser pressure should be about 26–26.5 in. of mercury vacuum or about 1.5–2 lb. per sq. in. abs.

NOTE.—The atmospheric relief valve, *G* (Fig. 430), must, of course, be closed when starting condensing. If there is a centrifugal condensate pump, it may have to be primed or a valve in the condensate line closed before a vacuum can be established in the condenser. If such a valve is closed, it must be opened again and the pump started as soon as a little condensate accumulates in the condenser.

NOTE.—To start several engines which have a common exhaust header and condenser (Fig. 430) proceed as follows: Start the engine warming and draining. With the valves in the exhaust lines from the engines closed, start the condenser. Close the drain valves and open the exhaust line valve on each engine just before it is started.

389. Condensers Should Be Started Before Starting The Main Engine And Stopped After The Main Engine Has Been Stopped.—If the engine is started first, it will exhaust out the atmospheric outlet and run non-condensing. Similarly, if the condenser is stopped first, the atmospheric relief valve will open and the engine will again run non-condensing. A certain amount of oily water will be then left in the condenser until it is again used.

NOTE.—THERE IS ORDINARILY LITTLE DANGER OF THE LOW-PRESSURE CYLINDER OF THE ENGINE SUCKING WATER FROM THE CON-

DENSER and causing damage. In a barometric condenser, the tail pipe is of such a length (over 35 ft.) that water cannot be sucked into the exhaust pipe. Ejector-jet condensers and low-level jet condensers (see Figs. 350 and 352) ordinarily employ vacuum breakers which open a valve in the condenser shell if the water level becomes too high. These condensers, moreover, are usually located below the engines and so arranged that if a vacuum does form in the exhaust pipe due to steam remaining therein after the engine has been shut down, no water will be sucked into the cylinder. Nevertheless, condensate pumps and wet-air pumps should always be run long enough after the main engine has been stopped to clear the apparatus of water.

390. Air Leaks Constitute The Most Important Source Of Trouble In Condensing Operation.—Leaks may be detected by means of a lighted candle. The flame will be sucked toward a condenser leak since in the condenser the pressure is below atmospheric. Leaks may occur at valve-stem and piston-rod stuffing boxes, in pipe joints—in fact anywhere in any joint holding the vacuum in the condenser, engine, air pump or piping. The effect of such leaks is either to decrease the vacuum, or to increase the power required by the air pump in maintaining the vacuum, or both.

NOTE.—THE UNAVOIDABLE DIFFERENCE BETWEEN THE THEORETICALLY POSSIBLE VACUUM AND THE ACTUAL ATTAINABLE VACUUM IS USUALLY LESS THAN $\frac{1}{2}$ IN. of mercury in all large condensers and is a little more for small condensers. The theoretical vacuum is that corresponding in a table of saturated steam properties to the temperature of the condensate which is withdrawn from the condenser.

391. Steam Engines Are Stopped In Exactly The Same Way Whether Condensing Or Non-Condensing as far as the engines themselves are concerned. The condensing apparatus must also be stopped afterward. If there is a centrifugal circulating pump, located above the water supply, the valves in the circulating-water line should be closed so that the piping will remain full of water and the pump, when again started, will not have to be primed. Before leaving a condensing engine, the vacuum should be broken, that is, either the atmospheric relief valve or some other valve should be opened so that atmospheric pressure will be restored in the condenser and piping.

NOTE.—CHANGING FROM CONDENSING TO NON-CONDENSING OPERATION is usually an accident due to the condenser becoming heated or air

bound because of the failure of one of the pumps. If the atmospheric relief valve does not stick, there will be no damage done when this happens. The pressure built up by the engine, when the condenser fails, opens the valve and the engine then exhausts into the atmosphere. (Some uniflow engines will, when the vacuum is destroyed, discharge steam from the cylinder relief valves. This condition should be accepted as a warning that the valves which increase the clearance volume, Sec. 334, should be opened.) To intentionally make the change from condensing to non-condensing operation, stop the condenser pumps, block open the atmospheric relief valve if desired and close the steam valve in the exhaust line to the condenser. To change back to condensing operation, first make sure that the condenser pumps are working properly and that there is a good supply of circulating water through the condenser. Then gradually open the steam inlet valve to the condenser while the atmospheric relief valve is being gradually closed.

392. In Starting A Simple Detaching Corliss-Valve Engine, warm up as described for slide-valve engines. Since the

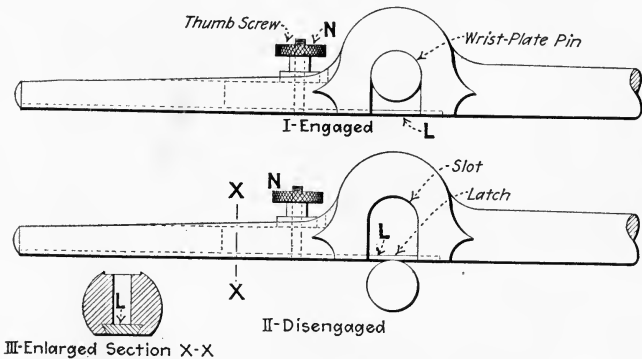

FIG. 436.—Hook-rod or reach-rod of Corliss engine showing latch for engaging wrist-plate pin. (To permit wrist pin to enter or leave slot, unscrew *N* until it leaves its seat, then pushing *N* to the left will also slide the latch, *L*, to the left and open the slot.)

exhaust valves of Corliss engines are usually located at the bottom of the cylinder there are often no drain valves or cocks. The steam which condenses in the cylinder drains through the exhaust valves and is removed by a trap in the exhaust line. In warming up a Corliss engine, first unhook the reach rod (or hook rod, Figs. 436 and 437) and close the latch so that the valves may be operated independently of the eccentric. By means of the starting lever, *L* (Fig. 438), which may be inserted in a socket in the wrist plate, alternately lift the

admission valves so as to admit steam to both ends of the cylinder. At first not enough steam should be admitted to move the engine piston; later, by rocking the starting lever, the

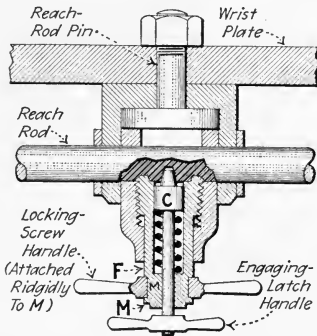

FIG. 437.—Reach-rod and latch. (This is another construction used for the same purpose as that in Fig. 436. To loosen, first unscrew *F* then pull out the handle connected to *M*.)

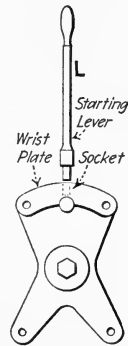

FIG. 438.—Corliss engine starting lever and wrist plate.

engine piston may be caused to reciprocate back and forth a part of a stroke. When the engine is thoroughly warm and ready for starting, open the throttle a little more and lift

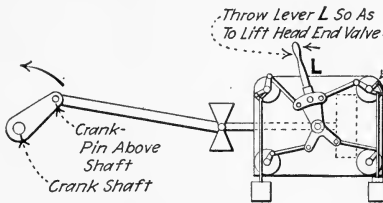

FIG. 439.—Showing how to start a Corliss engine running "over." (For engines with wrist plates of a construction different from that here shown it may be necessary to move the lever, *L*, in the opposite direction from that in which the piston is to move. But for the crank position shown in the above illustration, the head-end admission valve should, in every case, be lifted to start the engine running over, that is, in the direction indicated by the arrow.)

the proper admission valve to start the engine in the desired running direction. That is (Fig. 439), to run "over" (Sec. 31), admit steam to the head end if the crank pin is above the shaft and to the crank end if the crank is level with the shaft. If the crank is on dead center and must be barred or jacked to a convenient starting position.

These directions assume a horizontal engine but the same methods may be readily applied to vertical engines. Operate the valves by hand until the engine attains sufficient speed to carry it, by momentum, at least one-half a revolution. Then

slide (swing or screw according to the construction used) the latch of the reach rod so as to allow the reach-rod pin to be caught and held properly. Then remove the starting lever and return it to its rack and gradually open the throttle wider to bring the engine up to speed. After the engine is running at normal speed and under control of the governor open the throttle valve to its maximum opening.

NOTE.—IF BY NEGLIGENCE THE GOVERNOR HAS BEEN ALLOWED TO FALL TO THE SAFETY POSITION, the engine will not start; see Sec. 216. In stopping after the preceding run the governor should have been brought to rest on the tart cam or block, *B* (Fig. 440; see also *S*, Fig. 247). If it is not on the cam it must be lifted to the starting position by hand or with a tackle before the engine can be started. After the governor lifts, the starting cam should fall out of the way of its own weight. If it does not, it should be so turned that, in case of an accident, the governor may fall to the safety position.

NOTE.—IN STARTING UNIFLOW OR POPPET-VALVE ENGINES observe the following instructions. Poppet-valve counterflow engines may, in general, be started as was directed in Sec. 387 for non-releasing Corliss engines.

Poppet-valve engines which operate on high-pressure superheated steam must be very carefully drained as they are warmed because, since the walls must be heated to such a high temperature, condensation during warming will be very rapid. For this reason, such engines should be very slowly started. In starting a uniflow engine, first drain all water from the steam manifold, cylinder heads and exhaust cages. Then close the drains and "crack" the throttle so that these parts may be warmed by the live steam. After ten or fifteen minutes again open all drains. Then turn the engine so that its crank is a little ahead of dead center and open the throttle a little, leaving the drains open for a few minutes so that all water may flow from the engine. Immediately after opening the throttle turn on the oil to all bearings. Allow the engine to run slowly for some minutes while all lubrication may be inspected for proper action. A new engine should be speeded up only in the course of two or three hours and all of its bearings should be left loose so as to peen themselves to a better wearing surface.

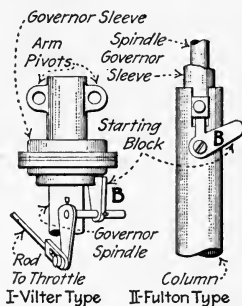

FIG. 440.—Starting block (or cam) for Corliss engine governors.

393. In Stopping A Detaching Corliss Engine, throw the starting cam or block (*B*, Fig. 440) of the governor into the

starting position before or immediately after turning off the steam. The governor will then come to rest on the cam and be in proper position for starting again. On some engines—the Vilter for example—there is a rod, running from the governor starting cam to the throttle valve, which automatically places the starting block in the starting position.

394. In Starting A Compound Corliss Engine, it is necessary to warm both cylinders. There is usually a by-pass, *P* (Fig. 441), or pass-over valve for admitting live steam to the receiver, from which the steam will pass to the low-pressure

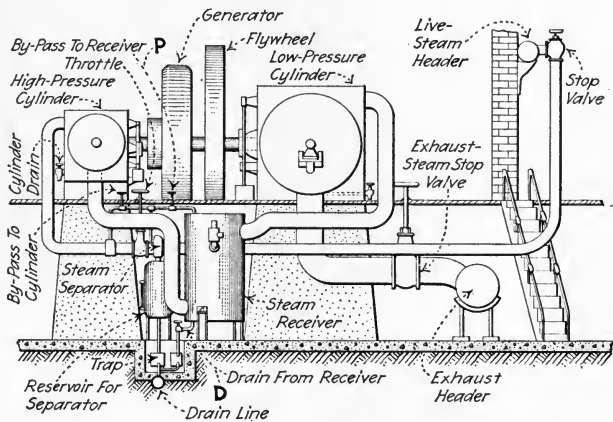

FIG. 441.—Some typical piping for a large compound engine.

cylinder. Thus this by-passed steam warms both the receiver and the low-pressure cylinder. The low-pressure and high-pressure cylinders may therefore be warmed simultaneously about as explained for simple engines in Sec. 392. The drain, *D*, on the receiver should be opened if not already so. The by-pass valve in *P* is given only a slight opening so that a high pressure will not be produced in the receiver. A cross-compound engine may usually be started by opening the throttle. If the high-pressure piston is on dead center, open the by-pass valve in *P* sufficiently to give several pounds receiver pressure; then the low-pressure piston will usually start the engine. If, after opening the valve in *P*, the engine does not start, then either the cut-off is so early that no admission valve

is open or there is excessive friction. If no admission valve is open, then one of the admission valves must be opened by lifting its dash-pot piston with a starting lever. If now the engine does not start, there being ample steam pressure and throttle opening, the friction is excessive or it is jammed. A bearing may have seized or the piston become rusted in or jammed in the cylinder. Tandem-compound engines are started just as are simple engines but for them only the high-pressure cylinder valves need be operated by hand.

NOTE.—IF THERE IS NO BY-PASS VALVE ON A COMPOUND ENGINE, steam must be worked into the low-pressure cylinder by working the high-pressure cylinder valves. The low-pressure cylinder does not need to be as warm as the high-pressure cylinder because it will operate at a lower temperature.

NOTE.—TANDEM-COMPOUND SLIDE-VALVE ENGINES ARE STARTED just as are simple slide-valve engines except that the low-pressure cylinder must also be warmed, drained and oiled. Cross-compound slide-valve engines are started similarly also; but such engines will nearly always start when the throttle and by-pass are opened. The use of the receiver is the same as explained above under compound Corliss engines.

395. Compound And Multi-Expansion Engines Are Stopped As Are Simple Engines, by closing the throttle. The only difference in the starting and stopping of multi-expansion engines is in the greater number of parts to be taken care of. As far as oiling and draining are concerned, each cylinder of a multi-expansion engine may be treated as a simple engine, although there is usually a central force-feed lubricator for multi-expansion engines; Sec. 507.

NOTE.—CONDENSING OPERATION OF COMPOUND ENGINES requires no special explanation beyond that already given. The low-pressure cylinder is the only one directly affected by the condenser. For more complete directions for condenser maintenance, see the author's *STEAM POWER PLANT AUXILIARIES AND ACCESSORIES*.

396. Regular Inspection Trips Should Be Made Through A Power Plant At Least Once Each Hour.—All equipment for which the engineer is responsible should be examined on such trips. On these inspection trips, listen for unusual sounds and knocks, feel for hot bearings, and look for leaks of all sorts. The oil supply in all oil cups and lubricators should

be replenished if likely to be necessary before the next trip. See that oil is being fed properly to the cylinders and bearings. Watch the boiler pressure to insure that the fireman is keeping a good steam supply. Note the condenser pressure as an indication of the condenser action. In short, check up every readily observed factor and detail which may influence the operation of the plant. An engineer should not leave the plant during his shift unless it is in charge of a competent assistant because trouble may occur at any instant when power-plant machinery is running.

397. In Cleaning Engines, do not use any emery or abrasive material which may get into the bearings and cause trouble. Various polishing powders which are free from grit are on the market and are preferred for this purpose. An engine should be cleaned immediately after it has been stopped—this is the best time. Water will spot the polished parts of engines if it is allowed to stand on them. The polished parts should be left covered with a thin film of oil. The oil will in a damp atmosphere prevent corrosion of the metal.

398. Laying Up An Engine consists in preparing it so that it will not suffer any ill effects from lying idle for a year or more if undisturbed. If the piston and valve rods are steel and soft packing is used, either the rod or the packing must be removed. If not removed the water with which the packing is saturated will corrode the rod. If the engine was supplied with plenty of oil at the end of its last run and was well drained while hot, the cylinder interior will thereby be ordinarily sufficiently protected. It will not be necessary to remove the head. It is a safe plan to remove slide valves and coat them and their seats with grease. The polished metal parts should be also coated with grease.

NOTE.—IF AN ENGINE IS TO BE IDLE FOR ONLY A FEW DAYS but is not to be laid up, it is advisable to run it for half an hour each day during the period to preserve the oil films on the cylinder walls and on the piston and valve rods.

399. Engines Should Not Ordinarily Need Overhauling More Often Than Once A Year even if they are in continuous service. Engines are more commonly run for several years before being completely overhauled.

400. Piston Rings Must Sometimes Be Replaced.—If excessive leakage past the piston is detected (see following note) it is probably due to worn, broken or poorly fitted rings. Loose or broken rings may sometimes be detected by the rattling sound when the engine is running. Broken rings should be replaced as soon as detected to avoid scoring of the cylinder walls by the broken ends. Methods of replacing them will be described in the following sections.

NOTE.—TO TEST FOR VALVE LEAKAGE OF SINGLE-VALVE ENGINES (*Power*, March 1, 1921) proceed as follows: A *general test of tightness* can be made by turning the engine over to such a position that the valve covers the ports of both ends of the cylinder at the same time. Then, upon admitting steam at the throttle valve, leakage will be shown by discharge of steam from open cylinder pet cocks or indicator connections, or by escape of steam from the exhaust pipe.

The leakage under running conditions can be approximately determined by blocking the flywheel and making tests at different points of stroke of the piston.

To test valve leakage of a throttling, D-slide-valve engine at a given point of piston stroke from the crank end of the cylinder, remove the cylinder head and with the piston in the crank end of the cylinder, turn the flywheel in the running direction, and block the wheel when the piston has arrived at the desired point; then gradually admit steam through the throttle and observe whether there is escape of steam from the steam passage of the head end into the cylinder or out of the exhaust pipe.

Piston leakage must be corrected before it is attempted to inspect leakage of the valve when it is in position for admission of steam for a piston stroke from the head end of the cylinder, because the crank end of the cylinder cannot be uncovered to distinguish piston leakage from valve leakage. When the piston packing has been made tight and cylinder head replaced, turn the flywheel in the running direction until the piston has arrived at the desired point of stroke from the head end of the cylinder. Then with the wheel blocked, open the throttle a little, and steam escaping from the exhaust pipe, or the cylinder pet cock or indicator connection of the crank end, will indicate the valve leakage.

With a single-valve automatic engine, proceed the same as for testing valve leakage of a throttling engine, but with the governor blocked in its average running position, and in positions giving other points of cut-off at which it is desired to test valve leakage.

401. To Replace A Cast-Iron Snap Piston Ring, proceed as follows: The piston, of course, must be removed from the cylinder and, if small, may be held in a vise (Fig. 442). The old ring is first pried out as shown in Fig. 443 by means of a

file and a strip of sheet iron or piece of hack-saw blade, *B*. The prying may be continued and other strips, *B*, inserted until the ring may be slipped off. The groove is now examined and if it appears to be worn out of shape as is groove

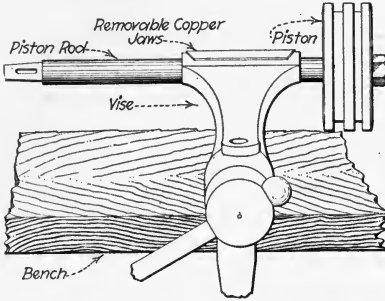

FIG. 442.—Piston rod held in vise for convenience in replacing snap ring.

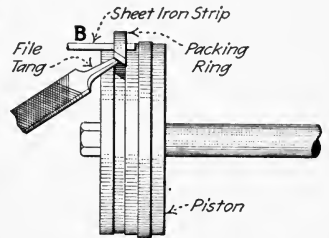

FIG. 443.—Prying end of packing ring out of groove.

A (Fig. 444) it should be trued up on a lathe so that its sides are flat as are those of groove *B*.

402. A Piston Ring Must Be Fitted To The Piston Grooves as shown in Fig. 445. If a complete snap ring is on hand, it

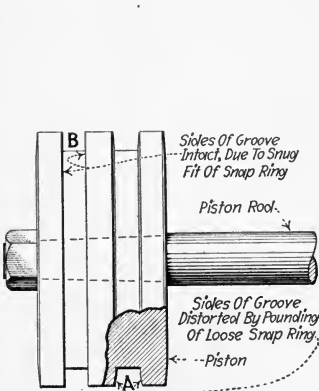

FIG. 444.—Illustrating wearing effect of poorly fitted snap ring.

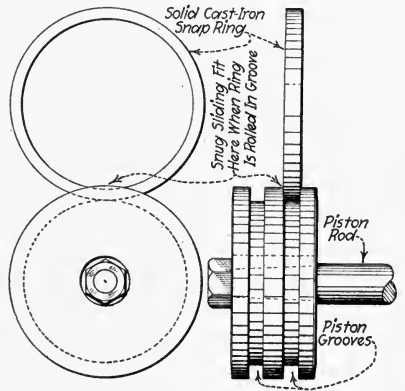

FIG. 445.—Illustrating fit of snap ring in piston groove.

is only necessary to grind it to the correct width and slip it on. If the rings on hand are solid rings (Fig. 446), it is well to grind or machine them to the correct width before slotting them.

Since, in time, the piston grooves wear wider, rings which are kept for replacement should be a few thousandths of an inch wider than the grooves and should be ground or machined to fit. If machine tools are available, they should be used.

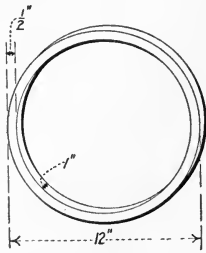

FIG. 446.—A solid cast-iron snap ring.

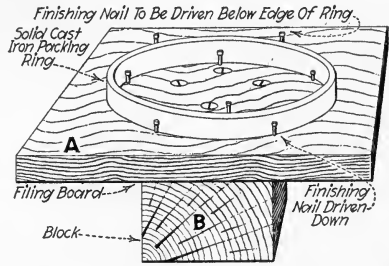

FIG. 447.—Packing ring fastened down for filing.

A few thousandths of an inch of metal may, however, be removed with a file.

EXPLANATION.—The ring may be nailed to a board for filing as shown in Fig. 447. If there is more than about 0.010 in. of metal to be removed, it usually pays to start filing with a flat bastard file (Fig. 448) and finish

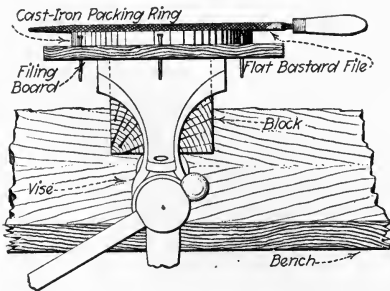

FIG. 448.—Cast-iron packing ring in position for filing.



FIG. 449.—Outside caliper for measuring width of cast-iron packing ring.

with a fine single cut file. The calipers (Fig. 449) are, for convenience, set at about $\frac{1}{100}$ in. over the correct size for the rough filing. When the ring is nearly down to size, it should be finished by testing with a surface plate (Fig. 450). Only one side of the ring should be filed. The other side, being true, should be left undisturbed as a reference plane

from which to measure. The surface plate is coated with a thin film of red lead and oil and the ring is wiped clean and rubbed on the plate. (Prussian blue is preferable to red lead but is more expensive.) Where the red lead rubs on the ring, the ring is high and should be further reduced with a file or scraper (Fig. 451). This procedure, if continued until the ring bears evenly on the plate, will insure a true surface on the ring.

NOTE.—SMALL PISTON RINGS MAY BE GROUND TO SIZE by rubbing on a piece of emery cloth tacked to a flat plate (Fig. 452). For the most accurate work, a lapping plate (Fig. 453) is used. The grooves in the plate are filled with a lapping compound of

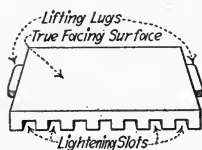

FIG. 450.—Cast-iron face or surface plate.

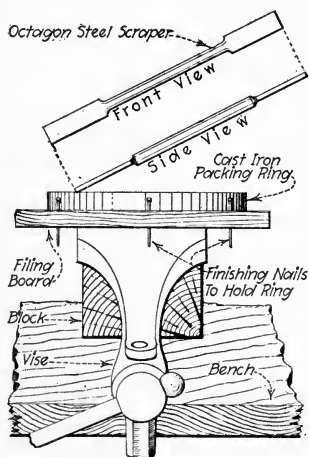

FIG. 451.—Cast-iron packing ring in position for scraping to fit.

emery and oil. The ring is rubbed over the plate and the compound which runs from the grooves, gets between the ring and the plate and grinds the ring to size.

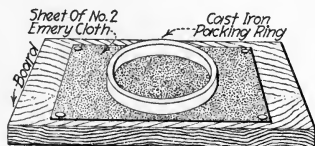

FIG. 452.—Cast-iron packing ring ground down on emery cloth.

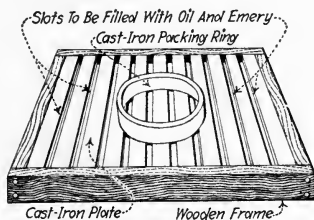

FIG. 453.—A lapping plate.

403. Solid Piston Rings Must Be Cut To Allow Springing Into Place.—Common snap rings are often turned eccentric so that they are thinner at one side than at the other. They are cut by means of a hack-saw at their thinnest section as shown in Fig. 454. The length of the segment thus removed

is the difference between the circumference of the ring and that of the cylinder. If the ring is not to be fitted as explained below, the ends should be filed down so that they will be about $\frac{1}{32}$ in. apart when the ring is in place in the cylinder. The solid rings are usually made about 2 per cent. larger in diameter than the cylinder.

NOTE.—A FINISHED RING MAY BE TESTED FOR FIT in the cylinder before it is sprung onto the piston. A coating of red lead on the cylinder walls will, when the ring is rubbed on it, show what portions of the ring bear on the wall. These portions should be slightly reduced by draw-filing. This operation will cause the ends to spring apart so that they will have sufficient play.

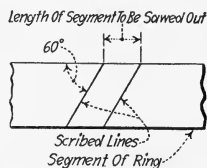

FIG. 454.—Method of laying off joint of cast-iron snap packing ring.

404. Worn One-Piece Piston Rings May Be Expanded To Snug Contact With The Cylinder Wall By Peening.—This is done by holding the ring on an anvil or heavy face-plate (Fig. 455) and striking its inner surface repeatedly with the peen of a ball-peen hammer. The ring should make solid contact with the surface on which it rests, and each blow of

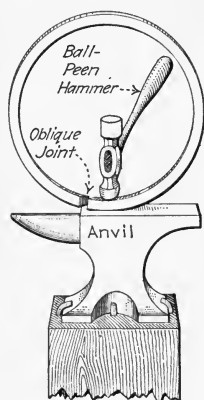

FIG. 455.—Peening a cast iron snap packing ring.

the hammer should be directly above the point of contact. The blows should be comparatively light and of equal intensity. The peening operation should begin at one end of the ring (Fig. 455) and should progress around the inner face to the other end. The hammer blows should not approach either edge of the ring nearer than about $\frac{1}{8}$ in.

405. The Repair Of Steam-Engine Valves is necessary whenever the valves are so badly worn that steam leakage past them is excessive. The repair always consists of: (1) *Truing up the surface along which the valves seat.* (2) *Making the proper adjustment so that the surfaces are kept together as they should be.* These repairs are explained below for the various valves.

EXPLANATION.—REPAIRING PLAIN D-SLIDE VALVES involves a resurfacing of the valve and its seat. Usually the valve can be finished in a

shaper or miller, but, if machine tools are not available, it may be *scraped* to a true surface. A surface plate (Fig. 450) is coated lightly with a red-lead-and-oil mixture and the valve rubbed lightly on it. The high spots of the valve face, which are now marked with red lead, may be scraped off with a scraping tool (see Figs. 451 and 467). (If deep grooves appear in the valve face, the high spots may first be filed off.) Each time the high spots are removed the valve should again be tried on the surface plate, continuing these processes alternately until the entire face of the valve is marked when applied to the surface plate. The valve may, after its face is true, be cleaned and itself coated with red lead. It should then be applied to the valve seat so as to mark the high spots on the seat. These may then be scraped off until a true fit is established between the valve and its seat. Oil grooves may be cut into the valve seat if desired, but they must not extend quite to the working edges of the seat lest they should provide passages for steam to blow through. Plain D-slide valves require no adjustment to keep the surfaces together. The steam pressure outside the valve insures good contact.

IN REPAIRING BALANCED SLIDE VALVES, the cover plate and the valve surface which rubs against it must also be fitted as is the valve against its seat. If machine tools are available, the surfaces may be readily machined. Otherwise, all surfaces must be scraped (or filed) to fit as directed above. The cover plate must then be so adjusted that it bears lightly against the valve. In some engines, screws are provided for this adjustment. In others, the cover plate is held from the valve seat by distance pieces which, to provide adjustment, must be filed down. Great care must be exercised in such engines that too much metal is not removed as this would necessitate using shims under the distance pieces. To test the cover-plate adjustment place a piece of thin (tissue) paper between it and valve. If, now, the valve can be moved by hand while pressure is applied to the cover plate (by having an assistant press against it firmly with both hands) the cover plate is too far from the valve. Adjust until, with the paper in place, the valve cannot easily be moved. Then see that, with the paper removed, the valve slides freely.

THE REPAIR OF PISTON VALVES usually necessitates the replacement of the valve or its seat, although some piston valves are capable of adjustment. Sometimes, when wear is not excessive, leaks may be stopped by simply refitting the rings in the valve (Sec. 400). If this will not suffice, see if the valve is adjustable. If it is, adjust it so that the wear is compensated for. If the valve is not adjustable, determine whether the wear is: (1) *All on the seat.* (2) *All on the valve.* (3) *On both the valve and the seat.* If either the valve or seat is made of brass, the wear will probably be on the brass part. The brass part can then be removed and replaced with a new piece. (These pieces should be kept on hand.) If the valve and seat are both worn, the seat must be rebored and the valve must be replaced by a larger one. In event of any replacement, the valve and seat should be ground to fit by introducing fine emery powder and oil between them and working them upon each

other until, when clean, they slide freely. The emery powder must then be very carefully cleaned out so that it cannot be carried into the cylinder.

THE REPAIR OF CORLISS VALVES is most effectively accomplished by boring out the valve seats and procuring from the manufacturer new valves of the proper size to fit the newly formed seat. For reboring the seat, a jig, somewhat similar to that shown in Fig. 464, may be employed. (Engine manufacturers usually have such jigs.) The new valve may then be "ground in" as explained above for piston valves. If reboring is not deemed necessary or advisable, the valves may simply be fitted by marking with red lead and scraping or filing until a tight fit is obtained.

THE REPAIR OF POPPET VALVES should scarcely ever be necessary because these valves are not subjected to rubbing action. However, should refitting be necessary, the valve springs and cages may be removed and the seats coated *lightly* with a mixture of fine emery and oil. The valve may then be placed upon the seat and rotated back and forth through a small angle for two or three minutes. The valve should then be removed, the valve and seat cleaned off, and inspected to see if a clear bright ring is obtained completely around each seat. If the surfaces are not satisfactory, the grinding process should be repeated until they are. It is preferable, in grinding poppet valves, to grind the valves immediately upon shutting down the engine and before the valves or seat have a chance to cool off.

406. Re-Babbitting May Be Necessary Where Bearings Have Been Partially Melted Out (Fig. 456), due to heating of the bearings while the engine was in operation. Also the normal running wear in the bearings may necessitate their eventually being re-babbitted. A bearing should preferably

be removed from the engine for re-babbitting. The general procedure is to pour melted babbitt metal into the shells of the bearing, one at a time, using a mandrel to form the inner surface of the babbitt. The mandrel is smaller than the shaft so that the surface of the metal may be accurately finished to fit the shaft. Pouring the metal around the shaft is not recommended. When it is done, thick shims should be used between the halves of the bearing so that the surface

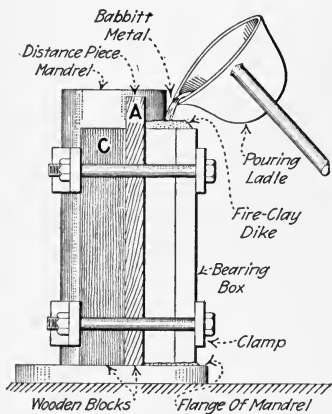
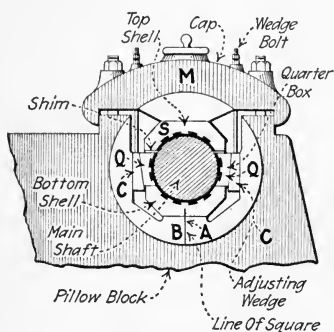

FIG. 456.—Pouring a main bearing box.

of the babbitt may be scraped and the play may, when the bearing is assembled for service, be taken up by using a thinner shim.

407. To Dismantle A Quartered Main Bearing (Fig. 457) for re-babbitting, the cap, *M*, and top shell, *S*, are first removed and the quarter boxes, *Q*, are drawn out. Shop marks, *A* and *B*, which indicate the proper position of the bottom shell, will generally be found on the end of the shell and on the bearing pedestal. These marks should coincide. Before the bottom shell can be removed, it will generally be necessary



[Fig. 457.—A quartered main bearing.

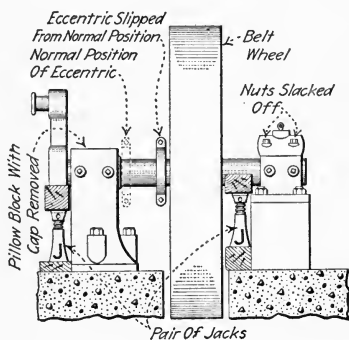

Fig. 458.—Main shaft jacked up to permit removal of bottom bearing shell.

to slip the eccentric and possibly the flywheel along the shaft. The nuts on the outboard bearing may then be slacked off and the shaft raised from the bottom shell with jacks *J* (Fig. 458), placed under the crank and outer end of the shaft. This will permit the bottom shell to be drawn out.

408. To Re-Babbitt The Boxes Of A Quartered Main Bearing, after the boxes have been taken from the pillow block, the old babbitt metal should first be chipped and pried from the boxes with cape and flat chisels. Each box may then in turn be clamped for babbitting (Figs. 456 and 459) to a mandrel having a diameter about $\frac{1}{16}$ in. smaller than the shaft diameter. A piece of iron or steel pipe screwed into a flange (Fig. 460) and finished in the lathe makes an excellent mandrel for this purpose. The wooden blocks, *A*, *B*, *C* and *D* (Figs. 456 and 459), should be cut and the clamps

adjusted as shown. Where the boxes cannot be removed from the engine they may be re-babbitted as shown in Figs. 461 and 462.

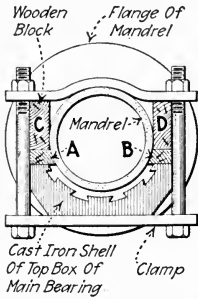

FIG. 459.—Main-bearing box clamped to babbitting mandrel.

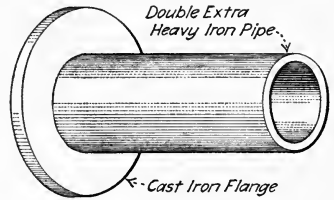

FIG. 460.—Mandrel for use in babbitting main bearings.

NOTE.—MAIN BEARING BOXES SHOULD BE BABBITTED WHILE WARM. This will prevent sputtering and blowing of the metal when poured and will facilitate the running of the metal to all parts of the box. Good

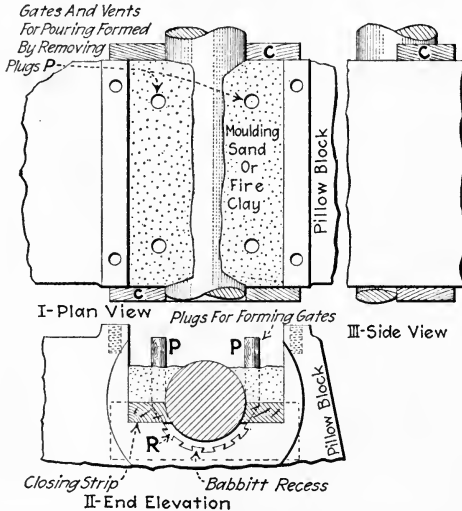

FIG. 461.—Tamping of journal with molding sand or fire clay. The plugs, *P*, are withdrawn and, after the ends of the babbitt recess, *R*, are closed with wooden collars, *C*, the bearing may be poured.

results may generally be assured if the box is warmed to a temperature of about 150 deg. fahr. before it is clamped to the mandrel.

NOTE.—THE OBJECT OF POURING A MAIN BEARING BOX IN A VERTICAL POSITION (Fig. 456) is to prevent shrinkage holes from forming in the

babbitt. Shrinkage holes will almost invariably result if a large bearing is poured in a horizontal position.

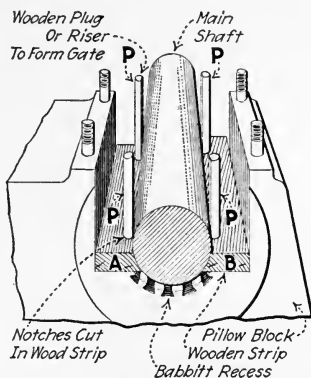

FIG. 462.—Showing method of closing, gating and venting babbitt recess in pillow block when re-babbitting a non-removable bottom shell. A bearing so prepared is tamped with moulding sand or fire clay as shown in Fig. 461. The plugs, P, are set into notches in A and B, which notches later form gates for the babbitt.

409. Freshly Re-Babbitted Bearings Should Be Peened And Finished.—

The metal should be forced tightly into the grooves (Fig. 463) by striking the inner surface with a peening hammer as shown. The bearing should then be bored to size with a jig (Fig.

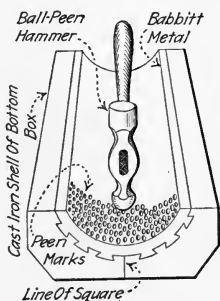

FIG. 463.—“Peening in” a main-bearing box.

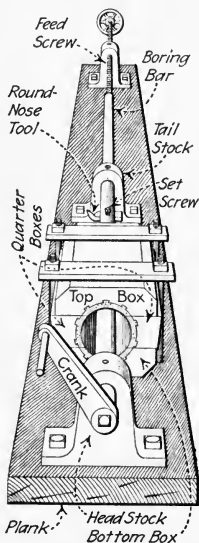

FIG. 464.—Improved jig for boring babbitted bearing boxes.

464) or on a lathe. Now, three or four oil grooves (Fig. 465) about $\frac{1}{4}$ in. wide should be chiseled (Fig. 466) or filed in

the babbitt to distribute the oil from the oil holes over the face of the bearing. The edges of the grooves should be chamfered. Finally, the bearing should be “scraped in.”

EXPLANATION.—IN SCRAPING A BEARING, Fig. 467, a portion of the shaft is coated with a very thin layer of red lead and oil. The bearing is then placed against the coated portion of the shaft and rotated a few

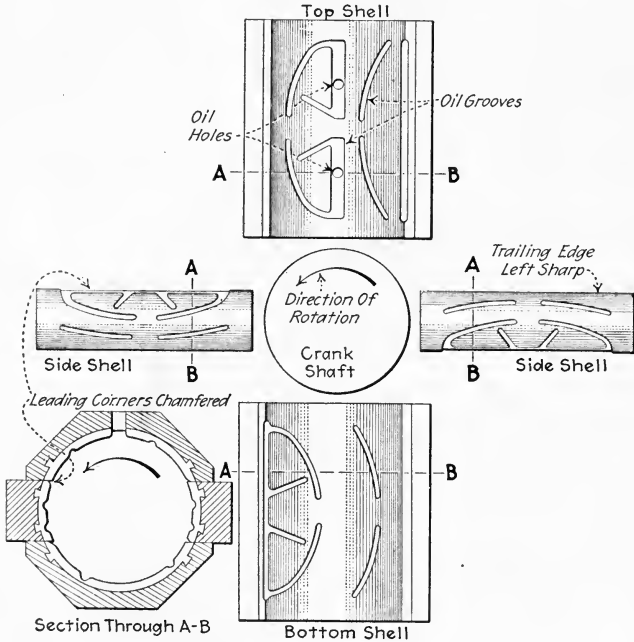

FIG. 465.—Correct oil grooves for main bearing. Note that the grooves are cut for a given direction of rotation. They first distribute the oil and then re-collect it to prevent it from running from the ends of the bearing. Only the leading edges of the bearing shells are chamfered.

degrees around the shaft. The “high spots” of the bearing (Fig. 467) are thus coated with the red lead. Then with a scraper these high spots are scraped off. Care must be exercised to insure that the scraping tool does not cut deep into the babbitt metal. The shaft should again be coated—by spreading the red lead to the spots from which it was removed—and the bearing again applied to it. It will be noted that now more high spots appear than before. These are again removed by scraping. After repeated scraping and marking it will be found that the bearing will bear marks all over its surface and that the unmarked surface is

very small. When no large unmarked surface appears, the bearing is ready to be placed in position on the engine. Bearings which are properly scraped will need little "running in" and are not likely to heat or knock when properly adjusted.

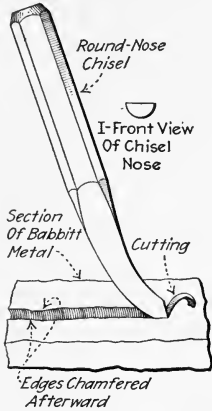

FIG. 466.—Cutting an oil groove.

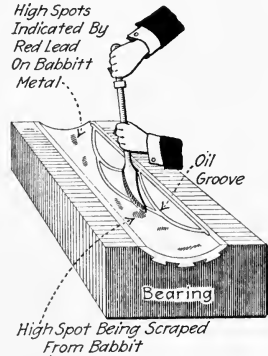

FIG. 467.—Illustrating method of scraping high spots from a bearing quarter.

410. Bearings Are Usually Adjusted To Compensate For Wear By Means Of Wedge Blocks And Shims.—Main and crank-pin bearings having wedge adjustments are shown in Figs. 457 and 468. In the main bearing (Fig. 457) the two side boxes are so adjusted by means of wedges, *C*, that the center of the shaft is kept over the reference line, *B*. The

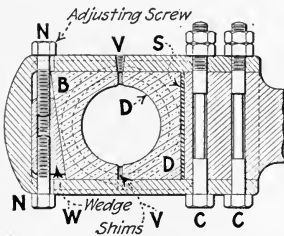

FIG. 468.—Crank-pin bearing with wedge and shims for adjustment.

connecting-rod crank-pin bearing (Fig. 468) is adjusted by means of the cap screws, *N*. These move the wedge, *W*, so as to push the end brass, *B*, closer to the stationary brass, *D*. Shims are sometimes used between the two brasses at *V*. Then to tighten the bearing, a thin shim is withdrawn and the wedge set tightly against the brass. The thickness of the

shims should be such that a good running fit is secured between the bushing and the crank pin. If no shims are used, the wedge must not be set tightly against the brass or

the crank pin will be clamped and will not turn freely. If there is much wear, a shim, *S*, should be inserted behind the stationary bushing. If this is not done, the effective length of the rod will be decreased due to the wear in the stationary bushing. This will have the effect of increasing the clearance at one end of the cylinder and decreasing it at the other. Finally, if after repeated adjustments the two brasses come together at *V* and still leave too much play around the crank pin (see Fig. 469), then the bearing is said to be "brass and brass."

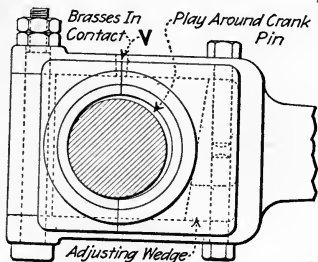

FIG. 469.—Showing bearing "brass and brass" with too much play.

The edges of the brasses must then be filed or planed off on a shaper or planer so as to permit further adjustment. A *crosshead* is adjusted as explained under Fig. 470. The wrist-pin bearing is adjusted exactly as explained for crank-pin bearings since these two bearings are usually similar in construction.

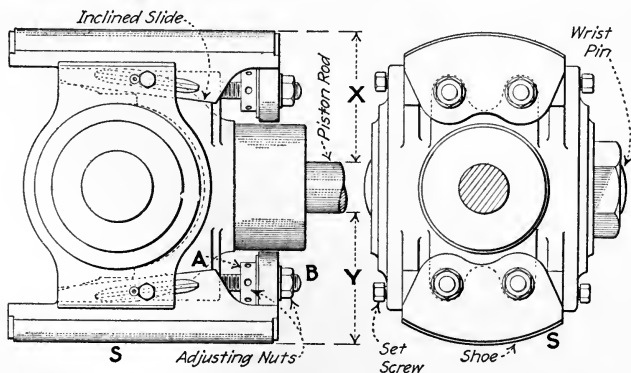

FIG. 470.—Illustrating method of adjusting crosshead shoes. To take up wear in the lower shoe, *S*, (which wears faster than the upper one) slack off on nuts, *A*, and tighten nuts *B*. When the adjustment is completed, the distances, *X* and *Y*, should be equal, unless the guide itself is worn.

NOTE.—SIMPLE SPLIT BEARINGS (Fig. 427) are often adjusted by removing a shim or substituting a thinner one and reclamping the halves of the bearing tightly together. The upper half may require scraping (Sec. 409) to insure a good fit.

NOTE.—THE PROPER AMOUNT OF CLEARANCE BETWEEN A JOURNAL AND ITS BEARING is about 0.001 in. for each inch of diameter for very accurately machined or ground parts such as motor spindles. For ordinary engine bearings, about 0.0015 in. for each inch of diameter is allowed. In taking up engine bearings for wear, it is usually impractical to measure the clearance. Therefore the bearings are often adjusted by removing shims until the journal will, when the bolts are tightened, be gripped; and then adding sheets of paper about as thick as the clearance desired until it will again turn. A very slight knock is preferable to excessive tightness in the bearing. A bearing which is too tight will heat and seize.

411. The Principal Causes Of Bearing Heating are: (1) *Not enough oil.* (2) *Bearing too tight.* (3) *Improper oil.* (4) *Grit in bearing.* (5) *External heat.* (6) *Improper design.* (7) *Bearing does not fit.* In old bearings, heating may be

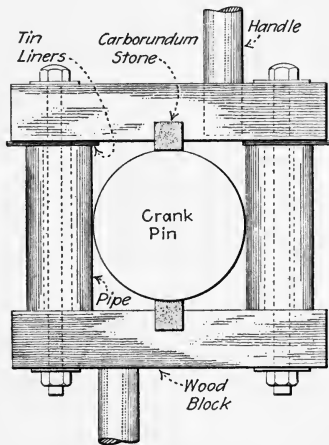

FIG. 471.—An improvised device for truing up crank pins without removing them.

due to warping of the engine frame or warping of the brasses, but heating is more common with new or newly fitted bearings. The remedies for the above troubles follow naturally from their causes. Failure of oil may be due to clogged oil holes or pipes or the oil grooves in the bearing face may be clogged or worn off. Too thin an oil will cause a bearing to heat; see Sec. 476. If a source of external heat cannot be removed, a high-temperature machine oil or cylinder oil must be used. If a bearing has begun to cut due to grit or a misfit, it should be taken apart and cleaned and scraped (Sec. 409). If it is loosened, flooded with oil and then turned over slowly for a time, it may run smooth again.

NOTE.—AN IMPROVED DEVICE FOR SCRAPING AND TRUING UP A CRANK PIN is shown in Fig. 471. The stones are set opposite the highest spots on the pin and the device is rocked back and forth to reduce them, plenty of oil being used. Tin liners are removed and the grinding

continued until the stones touch evenly when the device may be revolved completely about the pin.

412. If A Wrist-Pin Or Crank-Pin Bearing Starts To Heat, the oil supply should be increased and a heavier oil run in. There is little else to be done to such bearings until the engine can be stopped. Then bearings which have heated should be taken apart and examined for the cause. If the brasses are badly warped or grooved, they should be refinished or replaced. Wires should be run into the oil holes to make sure they are clear. The new or newly finished brasses should be left a little loose at first to avoid a repetition of the trouble. The inner edges (V, Fig. 468) should be rounded or recessed to prevent them from scraping the pin.

413. If A Main Bearing Starts To Heat it should immediately be loosened and flooded with oil. If the heating continues, a mixture of cylinder oil and graphite may be worked into it in any convenient way. A mixture of oil and powdered talc or soapstone may also be used but the engine should be slowed down if possible when such mixtures are used. Water may be used on the shaft to keep it cool but if there is any grit in the water it should not be allowed to run into the oil passages or get between the rubbing faces. It is not advisable to apply water to the outside of the bearing box as this may cause the bearing to seize.

414. If A Main Bearing Becomes So Hot That It Burns The Hand Or Smokes, the engine must be slowed down immediately or the bearings will be melted out. Then with the engine turning over slowly, loosen the bearing slightly and work cylinder oil into the bearing. One of the above oil mixtures should then be worked into the bearing. Water should be used cautiously on a very hot bearing or shaft to avoid cracking and warping. After the bearing has cooled somewhat and is well oiled the engine may be stopped. The bearing must then be repaired according to the extent of the damage—scraped, refinished or re-babbitted.

415. Packings For Steam Engines should be carefully selected and kept on hand. For packing piston rods, soft fiber packing, flexible metallic packing and regular metallic packing are used. Soft packing should be used only where

low first cost is essential or where the rod is so badly scored that a metallic packing cannot be utilized. Soft packing is preferably ordered in rings (Fig. 472) which should fit neatly around the rod. But it may be ordered in coils and afterward cut into rings. For stuffing boxes over $\frac{3}{8}$ in. in width between the rod and the wall, the soft packing should be ordered to fit the box. Smaller sizes may be ordered to fit also but small boxes are usually packed with twisted or braided coil packing

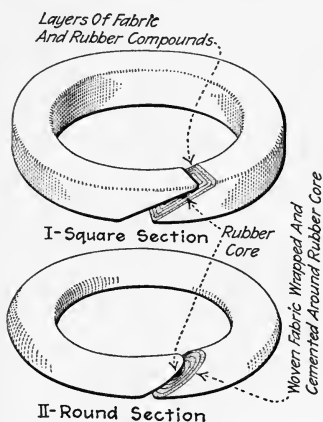

FIG. 472.—Square and round-section soft ring-packing.

which is fed into the box so as to form a loose spiral. In general, soft packings in which rubber is in direct contact with the rod should be avoided. In general, metallic packings are more economical and satisfactory in the long run, than are soft packings. Flexible metallic packing is used just as is soft fiber packing and can be used on slightly scored rods and for superheated steam. It is cheaper than regular metallic packing but it will not last as long and produces more friction. Regular metallic packing (Fig. 369), aside from its high first cost, has decided advantages when applied to new or unscored rods; regular metallic packings will usually last as long as the engine, can be used with highly superheated steam, have little friction and do not absorb water. A water-saturated packing will corrode the rod. In ordering regular metallic packing, a sketch giving the shape and all interior dimensions of the stuffing box and the rod diameter should be sent with the order. For the water ends of pumps, flax or hemp packings are usually used but various metallic packings are recommended by their makers and are probably more economical for this service.

NOTE.—SHEET PACKING for valve-chest covers and flanged joints is usually about $\frac{1}{32}$ to $\frac{1}{8}$ in. thick. For temperatures below about 300 deg. Fahr., rubber composition sheet packing is widely used. Corrugated copper gaskets or sheet asbestos packing may also be used for

this service. For higher temperatures, copper or asbestos gaskets should be used. A gasket of copper with asbestos inserts is used for very high temperatures and pressures but is too expensive and unnecessary for common service.

NOTE.—SOFT PACKING MUST USUALLY BE REPLACED EVERY FEW MONTHS. To replace the packing, simply unscrew the gland nuts, slide the gland along the rod, and pull out the old rings with a packing hook. The new rings should fit neatly, as in Fig. 473-II, and should be coated with graphite and oil before they are inserted. The joints of the different rings should alternate on opposite sides of the rod. The gland should be tightened only enough to prevent any considerable leakage. With a very good fit, the nuts need be only hand tight. Be careful in tightening valve-stem glands on automatic engines so as not to introduce much friction; otherwise the governor action will be hindered. It is a good plan to first apply a considerable pressure on the gland to

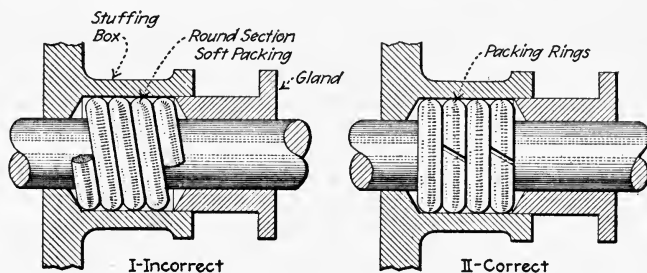

FIG. 473.—Showing incorrect and correct arrangements of packing in stuffing box.

force the packing firmly into place. The gland nuts should then be slacked off somewhat. For small rods, the procedure is the same except that it is not necessary to have the packing in rings. Twisted or braided coil packing may be fed into the stuffing-box so as to lie neatly in spiral form.

416. If An Engine Gets Out Of Line, some of the bearings are likely to be cramped or caused to knock. By getting out of line is meant shifting of some essential part of the engine so that it is in the wrong position with respect to the rest of it. For instance, one crank-shaft bearing may be higher than the other due to settling of the outboard bearing foundation. Settling of the guide pedestal (Fig. 474) has, in some instances, caused knocks. Warping of the frame or other parts or incorrect adjustment of the main bearings may also throw the engine out of line.

NOTE.—FOR AN ENGINE TO BE IN LINE, the following conditions should obtain: (1) *The axial center line of the shaft and its bearings should be level and should intersect the axial center line of the cylinder at right angles.* (2) *The guides should be parallel to each other and to the*

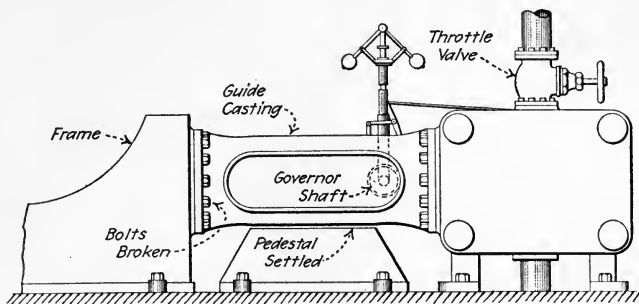

FIG. 474.—Showing settling pedestal which caused the engine to settle out of line and knock.

axial center line of the cylinder. (3) *The wrist pin and crank pin and their bearings should be parallel and parallel to the shaft.* (4) *In most engines, the stuffing box and piston rod should be concentric with the cylinder and the guides equidistant from the center line of the cylinder.* (5) *The*

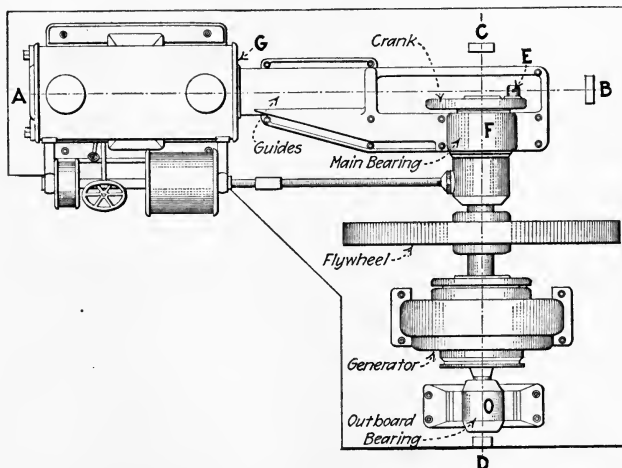

FIG. 475.—Plan lay-out of direct-connected simple engine with outboard bearing.

center, *E* (Fig. 475), of the crank-pin journal should lie in the vertical plane of the cylinder axis, for all positions of the crank pin.

NOTE.—THE ORDER IN WHICH THE VARIOUS ALIGNMENTS ARE MADE OR CHECKED is important. If it is suspected that several

alignments (Fig. 475) are "off," the order in which they should be corrected is as follows (1) For a horizontal engine, level the cylinder; for a vertical engine plumb the cylinder. (2) Stretch the center line of the cylinder. (3) Stretch the center line of the shaft. (4) Square shaft center line with cylinder. (5) Level center line of shaft. (6) Test alignment of guides. (7) Test alignment of crosshead and wrist pin. (8) Test alignment of crank pin. (9) Test alignment of connecting rod brasses.

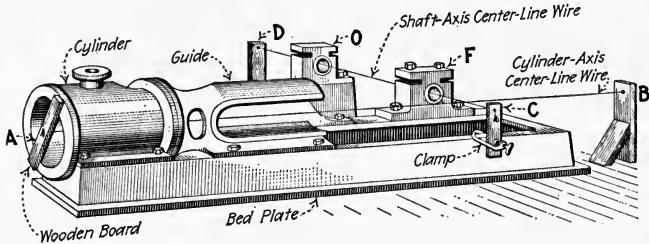

FIG. 476.—Center-line wires in position for aligning an engine.

EXPLANATION.—The following method of aligning an engine is adapted for use in erection and in re-assembling during overhauling. Fig. 475 shows a plan view of a simple engine direct connected to a generator. Assume that the main moving parts, namely the piston and rod, the crosshead and connecting rod, crank shaft and generator armature are all removed. Bolt a board, A (Figs. 475 and 476), across the end of the cylinder between two cylinder-head studs and stretch a fine steel ("piano") wire or a strong small-diameter "fish line," AB, between A and an improvised wooden block or batter board, B. The wire, which should be about $\frac{1}{64}$ in. in diameter, is carefully located in the center of the cylinder at A by means of a pair of dividers or inside calipers.

The location of the other end is found by trial so that the wire passes through the center of the cylinder stuffing box (Fig. 477) as determined by using a pair of inside calipers around the wire. Then the wire, CD, is stretched so that it is level, passes through the axis of the main bearing, F, and is at right angles to AB. A spirit-level and carpenter's square may be used for this operation or a triangular wooden templet may be laid off for squaring the wires for large engines. A triangle with sides of 8 by 6 by 10 ft. will have a square corner. If CD passes below AB, a liner should be inserted under the bearing to lift the bearing into place. If the outboard

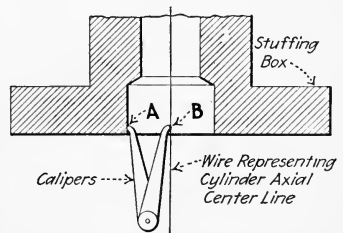

FIG. 477.—Method of locating center-line wire in the center of an engine stuffing box. The distance, AB, should be the same in every direction.

calipers are used for this operation or a triangular wooden templet may be laid off for squaring the wires for large engines. A triangle with sides of 8 by 6 by 10 ft. will have a square corner. If CD passes below AB, a liner should be inserted under the bearing to lift the bearing into place. If the outboard

bearing is found to be out of place with respect to *CD*, it should be shifted or shimmed into place. If, the shaft having been squared with the cylinder axis, the center, *E*, of the crank-pin journal does not fall on the axial center line of the cylinder as shown, it usually means that the shaft collar or eccentric has slipped longitudinally on the shaft.

417. An Engine May Be Lined Up Without Removing The Moving Parts by a method shown in Fig. 478. This method

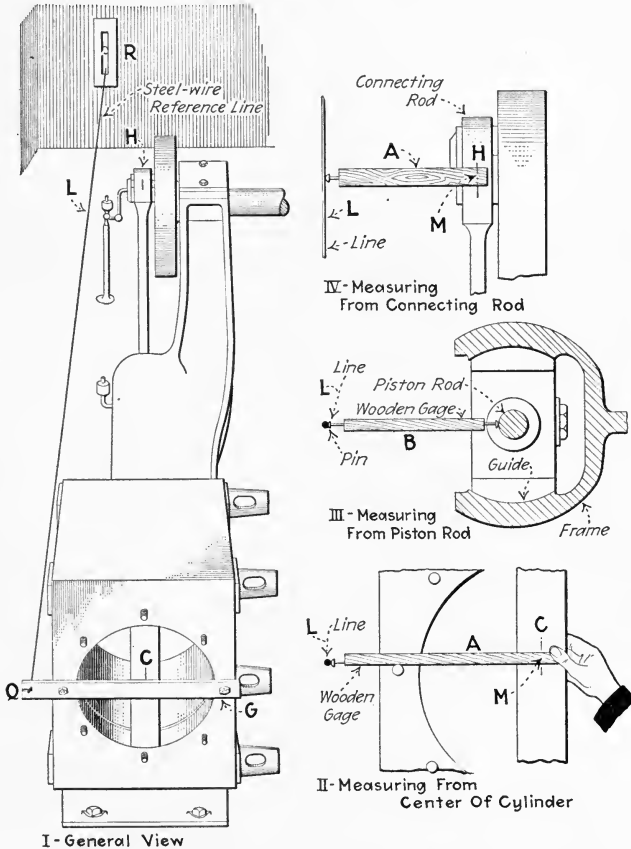

FIG. 478.—Showing quick method of checking engine alignment. (Southern Engineer Kink Book.)

is adapted for use when locating trouble and at other times when it is inconvenient to dismantle the moving parts of the engine.

EXPLANATION.—A board, *GQ* (Fig. 478), is bolted across the end of the cylinder between two cylinder-head studs so that it extends beyond the engine frame. The center of the cylinder is located on the board at *C* by means of a pair of dividers or inside calipers. The point *Q* is located level with *C*. A wire, *QR*, is stretched level as shown and as nearly parallel with the cylinder axis as it can be aligned with the eye. Make a gage, *A*, by driving a pin or brad into the end of a stick of wood. Scratch a line, *M*, on *A* so that *M* falls on *C* when *A* is held to the line as shown in *II*. Also make a gage, *B*, having a pin or brad in each end. Make *B* shorter than *A* by a distance which is equal to the radius of the piston rod. With the engine on approximate crank-end dead center, apply gage *B* between the piston rod and the wire line near the stuffing box as shown in *III*. Move the end, *R*, of the line, *L*, horizontally so that *B* will just touch the rod and line as shown. The wire line should now be parallel to the cylinder axis.

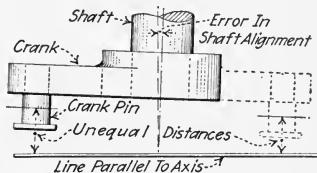

FIG. 479.—Showing how incorrect shaft alignment may be detected at dead centers by measuring from a line which is parallel to the cylinder center line.

The gage, *B*, is then applied to the rod near the crosshead. If the guides are in line, the distance will be the same as at the stuffing-box. Ordinarily the proper location for the line may be located by measuring from the rod only near the crosshead because the guides are seldom out of line; but it is well to check this condition by a measurement near the stuffing-box. The gage, *A*, is now applied to the connecting rod, measuring to a scribed line, *H*, above the center of the crank-pin bearing. Mark the position of *H* on the gage, turn over to head-end dead center and mark the position of *H* again in the same way. If *H* falls first on one side of *M* and then on the other, or is at a different distance from *M* at the two dead-center positions, the outboard bearing should be shifted to bring the shaft into line. How the difference in distance from the line shows an incorrect shaft alignment may be understood from Fig. 479. If there is a considerable constant difference between *H* and *M*, the crank pin is out of line due to the shaft slipping longitudinally.

418. The Normal Wear Of The Main Bearing May Cause The Shaft To Get Out Of Line.—As the bearing wears, the shaft sinks continually lower at the crank end. The amount of this wear may be measured by means of a tram or trammel gage, *G* (Fig. 480). A center-punch mark is made on the base plate of the engine or the bottom of the crank pin and the long end of the gage inserted therein. The gage should be of such a length that the short end will fall in the center of the shaft

when the shaft position is correct. The amount of movement from this position may then be readily detected. When the shaft gets considerably lower than its correct position, it may be restored by jacking up and inserting a liner under the lower shell of the bearing.

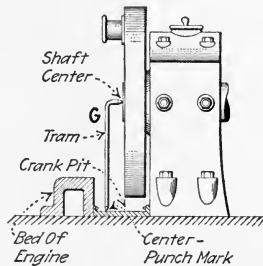

FIG. 480.—Showing a method of gaging the wear of a main bearing.

419. A Table Describing The Principal Causes Of Engine Knocks And Their Remedies is given on the opposite page.

CAUTION.—DO NOT TIGHTEN ANY BEARING TO STOP A KNOCK UNLESS IT IS KNOWN THAT THE PARTICULAR BEARING IS LOOSE and is causing the knock. If a bearing which is already in good condition is tightened to stop a knock which is caused by something else, the bearing will be likely to heat and will have to be carefully readjusted. If a certain bearing is thought to be the cause of the knock but there is some uncertainty, tightening the bearing may be tried but the original position of the bolts should be carefully noted; and, if the tightening does not diminish the knock, the original condition should be restored.

NOTE.—THE APPARENT LOCATION OF A KNOCK IS OFTEN DECEPTIVE due to the fact that the sound travels along the engine frame. It requires experience to locate a knock with any certainty. Nearly all knocks occur at the ends of the stroke, bearing knocks occurring just as the direction is reversed at each end. Cylinder knocks due to water or deposits in the cylinder are more likely to occur at one end only. A violent knock just after an adjustment may be due to interference such as the piston striking the cylinder head after a careless connecting-rod bearing adjustment.

NOTE.—BY FAR THE COMMONEST CAUSES OF KNOCKS ARE WATER IN THE CYLINDER AND LOOSE BEARINGS. Remedies for these should therefore be tried first unless the cause is known to be some other. If the knock persists after this, the other remedies should be tried in order of their probability somewhat as given in the table.

419A. Table Of Causes Of Engine Knocks And Their Remedies.

Cause	Location	Detected by	Character of sound	Remedy
Water in cylinder	Cylinder	Sound or vibration	Dull metallic	Draining cylinder and checking flow at stop valve.
Loose or poorly fitted brasses	Connecting rod	Sound	Sharp metallic	Adjusting brasses.
Loose main bearing	Main bearing	Sound or vibration	Dull metallic	Adjust bearing.
Crosshead loose in guides	Crosshead	Sound	Dull metallic	Adjusting crosshead shoes.
Too early admission or compression	Connecting rod	Sound or indicator diagram	Dull metallic	Adjusting valves.
Too little compression	Connecting rod	Sound or indicator diagram	Dull metallic	Adjusting valves.
Broken piston ring	Cylinder	Sound or leakage	Sharp rattle	Replace ring.
Loose piston or follower plate	Cylinder	Sound	Sharp or dull metallic	Insert washers if necessary, tighten piston rod or follower bolts.
Rough cylinder wall or deposit	Cylinder	Sound or friction	Sharp or dull metallic	Scraping or reborring.
Crank pin or shaft not "lined up" with cylinder or guides	Crank pin	Sound or measurement	Sharp metallic	Aligning shaft.
Guides not "lined up" with cylinder or crank	Crosshead	Sound or measurement	Dull or sharp metallic	Aligning guides.
Wrist pin out of line	Crosshead	Sound or measurement	Sharp or dull metallic	Reborring wrist-pin bearing.

420. The Location Of A Knock Can Often Be Ascertained By Means Of a Sounding Rod.—Any light metal rod which is about 2 or 3 ft. long and which has one reasonably smooth end may be used as a sounding rod. One end is placed against the stationary part of the engine where the knock is suspected. The smooth end is placed against the side of the operator's face near his ear. Try several locations in this way. Where the sound is greatest, the knock is probably located. A wooden rod may be used but is not quite as good.

421. When An Engine Runs "Under" (Sec. 32), knocks are likely to occur in the guides. It may be noted (see Fig. 20) that when an engine runs "under," the thrust on the connecting rod tends to lift the crosshead except at dead centers. Therefore the crosshead will ride against the upper guide during the stroke and against the lower one at dead centers. If there is any play between the crosshead and the guides, the crosshead will strike the upper guide and fall to the lower guide at the end of each stroke, thus causing a knock. When the engine runs "over" the crosshead always rides on the lower guide. Engines are more often run "over" for this reason.

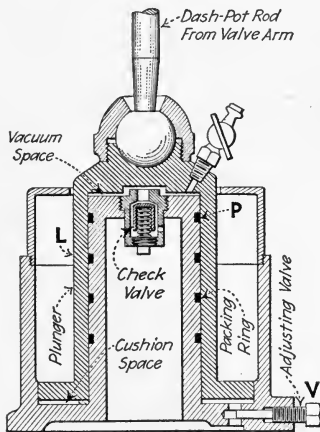

FIG. 481.—Showing inverted vacuum dash-pot for Corliss valve gear.

422. Troubles Of Dash-Pots For Corliss Releasing Gears are, principally, as follows: In some designs the vacuum created by the lifting of the plunger, *L* (Fig. 481), is relied on to return the pot to its closed position. The vacuum cylinder may be packed with cup washers or packing rings, *P*, which must be in good condition to maintain the necessary vacuum. Failure of the vacuum will prevent the admission valves from closing rapidly. A spring may be used temporarily when this occurs. If the valve, *V*, through which the air is released from the cushion space is open too wide, the dash-pot will slam. If it is not open wide enough, the dash-pot is likely to bounce or not return to rest in time

for the next stroke. Also it may not allow the valves to shut off completely.

423. The Following Information Concerning Each Engine Should Be Ascertained and kept for ready reference so that repair parts may be ordered promptly. A copy of this form, properly filled in, should be framed under glass and mounted near each engine.

DATA FORM—ENGINE

Date when made up.....
 Engine No..... Maker.....
 Type..... Age.....
 Kind of engine.....
 No. of cylinders..... Diam..... Length.....
 Thickness..... Cylinder head thickness.....
 Cylinder head bolts, No..... Size.....
 How is cylinder supported.....
 Piston, type..... Area.....
 Thickness..... Construction.....
 Rings, No..... Width..... Diam.....
 Piston rod diam..... Length..... Taper.....
 Thread on end of rod at piston..... Crosshead.....
 Follower bolts, No..... Size.....
 Crosshead type.....
 Length..... Height..... Width.....
 Wrist pin, diam..... Length.....
 Shoes, length..... Thickness..... Material.....
 Method of attaching wrist pin.....
 Connecting rod, type.....
 Length..... Diam. min..... Max.....
 Box adjustment.....
 Wedge bolts, No..... Size.....
 Crank, type..... Throw.....
 Crank pin diam..... Length.....
 Eccentric rod diam..... Length.....
 Eccentric throw.....
 Rocker arms, type.....
 Length..... Travel..... Pin sizes.....
 Bearings, type..... Length.....
 Material in boxes.....
 Adjustment.....
 Governor type..... R.p.m.....
 How driven.....
 What does governor act upon.....
 Engine r.p.m..... Steam pressure.....
 Foundation material..... Floor area.....
 What does engine drive.....

424. Careful Records Should Be Kept of engine performance and other events in the engine room. These records will enable the plant manager to determine the effect of changes which he may make in the methods of operation and will show in what ways improvements in management may be made. The form shown in Fig. 482 may be found useful in keeping such records.

QUESTIONS ON DIVISION 13

1. Name three precautions to be taken in replacing a cylinder head. How may piston leakage be judged?
2. Name three conditions which should obtain in a valve chest before the cover is replaced.
3. What, in general, should be done by an engineer in taking charge of an engine room with which he is not familiar?
4. Name some points which should be noted in inspecting condensers?
5. Give two suggestions to aid in remembering power plant piping connections.
6. What conditions of steam and water piping arising from neglect should be corrected?
7. How may traps and water gages be inspected?
8. Name a few supplies which should be kept on hand in an engine room.
9. Make a sketch of piping used in warming up a simple engine and explain its use.
10. When should gravity-feed bearing lubricators be started? Cylinder lubricators?
11. Should the condenser be started before or after starting a condensing engine? Why?
12. After starting an engine when may its drain valves be closed?
13. How is steam worked into both ends of a slide-valve engine which is not provided with by-pass piping? How into the low-pressure cylinder of a compound engine?
14. In stopping the condensing engine, when should the wet-air pump of a low-level jet condenser be stopped?
15. What is the chief source of trouble in condenser operation? How may it be located?
16. Explain how to change from non-condensing to condensing operation.
17. What may cause a condenser to fail and the engine to exhaust through the relief valve?
18. What is the purpose of a governor starting cam on a detaching Corliss engine? A starting lever? A reach-rod latch?
19. How can a detaching Corliss engine be started when the governor is in "safety position"?
20. What difference is there in the starting of a cross- and a tandem-compound engine?
21. What is the danger in using emery powder in cleaning the polished surfaces on an engine? What is the preferable method of cleaning polished work?
22. How may a solid snap piston ring be removed? How may the fit of a worn snap ring be restored?
23. Explain a method of truing up a filed piston ring by using a surface plate. Explain how the fit of a ring in a cylinder may be tested.
24. May a good bearing be ordinarily made by pouring babbit around a shaft and leaving the bearing surface as it forms? Why? How should oil be distributed over the face of a bearing? Explain with sketches.
25. What is the purpose of a mandrel which is used in babbitting a bearing? How may one be made? In what position is a main bearing preferably babbitted? Why?
26. What is the danger of repeatedly taking up crank-pin bearing wear by moving only one brass?

27. What should be done when a crank-pin bearing is "brass and brass" and is still too loose?

28. How are simple split bearings adjusted? What clearance should there ordinarily be between an engine journal and its bearing?

29. Name six conditions which will cause bearings to heat.

30. What can be done to stop the heating of a crank-pin bearing without stopping the engine?

31. What should be done when a main bearing starts to heat?

32. Give general directions for handling a badly overheated main bearing.

33. What are some advantages of metallic packing on good rods?

34. How should metallic packing be ordered? How soft packing over $\frac{3}{8}$ in. wide?

35. What are possible causes of an engine getting out of line? What are the results?

36. In what order should the various alignments of an engine be made in erecting? Explain the procedure using a sketch.

37. If, when erecting an engine, the correct axial center line for the shaft is found *not* to pass through the center of the outboard bearing, what should be done?

38. How may the alignment of an engine be tested without dismantling it? Explain with a sketch what is indicated if the crank pin is a different distance at the two dead centers from a reference line which is level and which is parallel with the cylinder axis.

39. Name six causes of engine knocks and their remedies. Which are the most common?

40. What danger lies in tightening bearings to stop any knock which occurs in an engine?

41. Why are engines usually run "over"?

42. What happens if the plunger in the dash-pot of a Corliss valve gear leaks excessively? What if the cushion air escapes too rapidly? What if it escapes too slowly?

43. Why should engine room records be kept?

44. Explain a method of repairing a plain D-slide valve without machine tools. How are piston valves repaired when the leakage is found to be excessive? Corliss valves?

DIVISION 14

USE OF SUPERHEATED STEAM IN ENGINES

425. The Use Of Superheated Steam In Engines Always Results In Some Gain.—Actual fuel savings, due to superheating an engine's steam supply, range from 6 to 20 per cent. Whether the expense of installing and maintaining the superheater (Figs. 483 and 484) is justified can be deter-

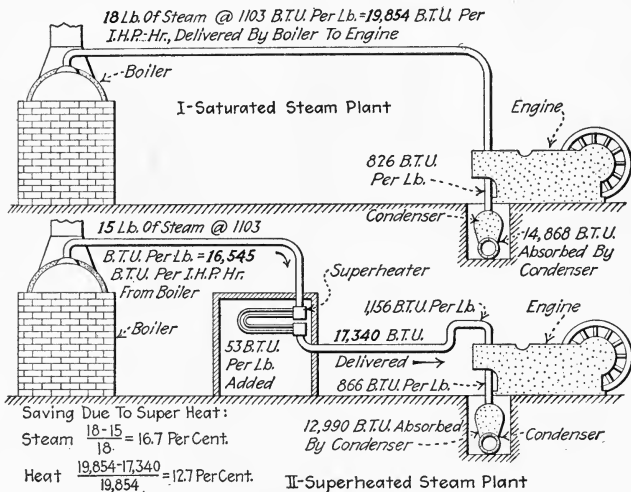

FIG. 483.—Diagram showing theoretical heat transfer calculated for saturated and superheated steam plants. The figures are based on one indicated horsepower hour. Steam pressure = 105 per sq. in. abs. Superheat = 100 deg. fahr. The condenser temperature = 116 deg. fahr. The heats are calculated above this temperature. A typical steam saving due to superheat is assumed.

mined only by comparing such expense with the value of the fuel saving which is effected by superheating the steam. This fuel saving in simple engines is about 1 per cent. for each 10 deg. fahr. of superheat. Whether a high initial steam pressure with slight superheat or a low pressure with high superheat

is the more economical depends on the type and other operating conditions of the engine (Secs. 432–435).

NOTE.—FOR DEFINITION AND THEORETICAL DISCUSSION OF SUPERHEATED STEAM, see the author's PRACTICAL HEAT. See also Div. 10. The efficiency of the ideal Rankine cycle is not materially increased by moderate superheat (see Sec. 315). But with superheated steam there is less cylinder condensation and less pressure drop from the boiler to the engine cylinder. Hence, while the use of superheated steam does not materially increase the Rankine-cycle efficiency it does increase the thermal efficiency and hence the Rankine-cycle ratio.

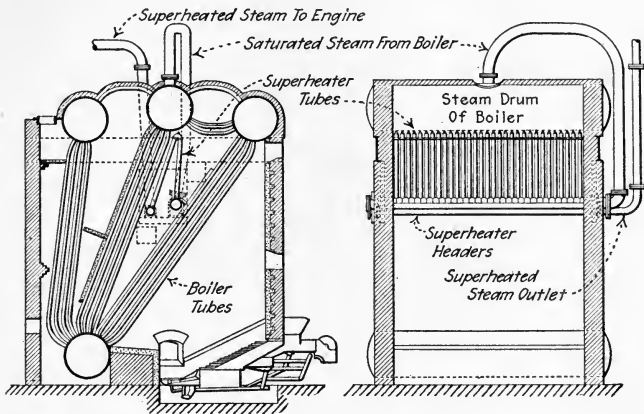

FIG. 484.—Typical modern superheater installation. (Superheater installed in boiler setting.)

426. The Differences Between Superheated And Saturated Steam at the same pressure may be enumerated as follows:

1. *Superheated steam is generated first as saturated or wet steam and then further heated in a superheater, practically no water being present, and is thus converted into superheated steam. That is, its temperature is raised above the boiling point at the given pressure.*

2. *The temperature of superheated steam is greater at the same pressure than that of saturated steam. Saturated steam at a given pressure exists at only one temperature—the boiling point at that pressure; but, at this same pressure, superheated steam may have any temperature above the saturated steam temperature.*

3. *The volume of superheated steam is greater than that of the same weight of saturated steam at the same pressure, that is, its density is less. Steam, in being superheated, expands so that its volume varies roughly as the absolute temperature. The exact volume which it occupies, however,*

must be found from a superheated-steam table or chart. Less weight of superheated steam is therefore required to fill a certain volume and thus for a given amount of work by an engine. This lesser weight of steam requires a lesser condenser and air pump capacity; or, conversely, results in a higher vacuum for a given condenser and air pump capacity.

4. *The total heat per pound of superheated steam is (Fig. 483) greater than that of saturated steam at the same pressure; also superheated steam contains more heat than does saturated steam at the same temperature.*

5. *Superheated steam may be cooled somewhat without condensation taking place.* Any abstraction of heat from saturated steam causes condensation but the superheat which superheated steam contains, in addition to the heat contained in saturated steam at the same pressure, may all be abstracted from superheated steam before any condensation occurs.

6. *Superheated steam, so experiments tend to indicate, decreases more in volume for a given abstraction of heat than does saturated steam.* This appears to be the cause of the expansion lines of indicator diagrams, which are taken while using superheated steam, to fall off somewhat more rapidly than they would were saturated steam used under the same conditions.

7. *Superheated steam, if brought into contact with a small amount of water, will evaporate all or part of the water; whereas saturated steam will not evaporate any water.* Therefore superheated steam never contains any suspended water in the form of fine droplets nor does it carry any water mechanically as does wet steam.

8. *Superheated steam has lower heat conductivity than has saturated steam, probably because there is no moisture in it.* Therefore it does not lose heat through the walls of a pipe as readily as does saturated steam. For this reason, it is usually more economical to transmit superheated steam than saturated steam at the same pressure, in spite of the higher temperature of the superheated steam.

9. *Superheated steam has less viscosity or fluid friction than has saturated steam.* Hence, there is less loss of pressure due to wire-drawing in engine valves when superheated steam is used. A given volume of superheated steam will ordinarily flow through a given pipe line in a given time with less loss in pressure than will the same volume of saturated steam. However, because of the lesser density of the superheated steam, the weight of superheated steam transmitted at a given pressure through a pipe is somewhat less than if the steam were saturated.

427. Valves For Engines Using Highly Superheated Steam are usually of the piston (Fig. 485) or poppet (Fig. 486) types. Locomotive and marine engines which operate on superheated steam usually have piston valves. Stationary engines for highly superheated steam usually have poppet valves. Simple slide valves can only be used for slightly

superheated steam because of their tendency to warp when exposed to the hot dry vapor. The maximum amount of

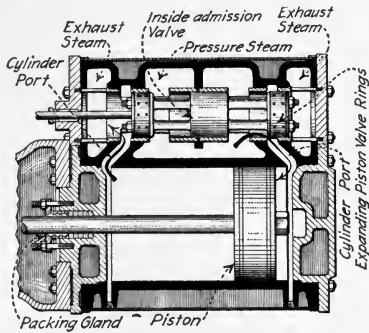

FIG. 485.—Section through cylinder of Eric-Ball piston-valve engine.

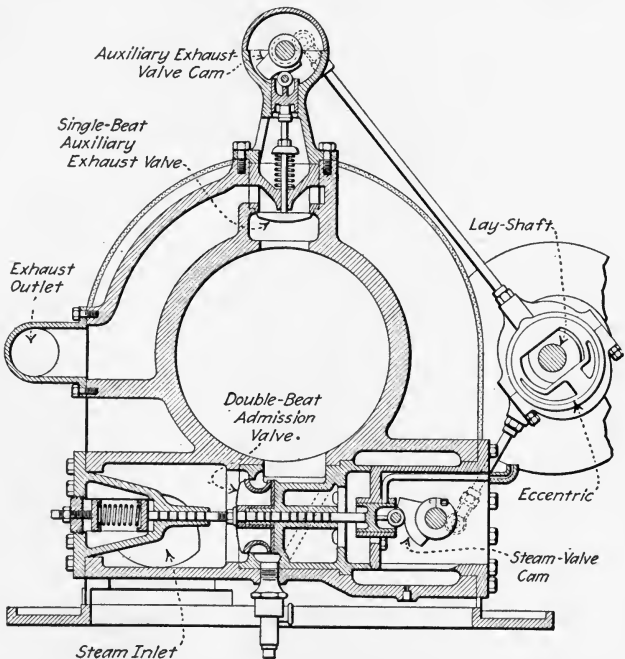

FIG. 486.—Section of poppet-valve engine cylinder of Hamilton uniflow engine. (Hooven Owens, Rentschler Co.)

superheat ordinarily used with valves of various types is shown in the following table.

428. Table Showing Maximum Pressures And Superheats To Which Engine Valves Of The Various Types May Be Subjected.

Valve	Pressure, lb. per sq. in. abs.	Superheat, deg. fahr.	Total temperature, deg. fahr.
Flat slide valve.....	125	50	395
Corliss.....	200	120	500
Piston.....	{ 175 250 }	{ 200 170 }	570
Poppet.....	250	200	600

NOTE.—GOOD PRACTICE WITH CORLISS VALVES IS TO USE MODERATE SUPERHEATS (about 50 deg. fahr.). The first 50 deg. fahr. superheat is the most cheaply obtained and is more beneficial than any other equal increase in superheat. Higher superheats than those indicated in the table are occasionally used but average practice is much lower than the values given.

429. Metals For Valves And Seats Which Are To Be Used With Superheated Steam are cast iron, cast steel, Monel metal and bronze. For safety valves, Monel metal seats and valve feathers are preferred by some manufacturers. Soft brasses cannot be used. Piston valves should, preferably, be cast from the same heats as their seats to insure equal expansion or contraction with change in temperature. Superheated steam has a greater tendency to cut the faces of valves when the valves are "cracked" (nearly closed) than has saturated steam. High-grade cast iron is used for Corliss and poppet valves with superheated steam up to about 550 deg. fahr. It has some tendency to "grow" (suffer a permanent increase in size) due to the action of high-temperature steam. Cast steel is used for valve bodies; bronze for piston-valve bushings.

430. Cylinder Oil For Engines Using Superheated Steam must be a high-grade oil which will not decompose at the steam temperature. Highly superheated steam will not condense in the cylinder of an engine when operating at full load. A small quantity of the correct heavy-bodied cylinder oil will then furnish efficient lubrication. Friction and high tem-

perature have a tendency to decompose unsuitable oil and form carbonaceous deposits. Therefore only a high-quality cylinder oil should be used. An engine operating under average light-load conditions on highly superheated steam requires a relatively small volume of steam per stroke, which though introduced in the cylinder in a dry condition will, at the end of the stroke, be partially condensed. Also, if the steam is initially only moderately superheated, it will enter the high-pressure cylinder in dry condition, but will cool, and toward the end of the stroke it will partially condense. Under these conditions a medium-bodied high-quality cylinder oil will furnish efficient lubrication. A number 2 or number 3 dark straight mineral oil is recommended in Table 482 for most superheated steam conditions. The Vacuum Oil Co. recommends its "Gargoyle cylinder oil 600-W" up to 600 deg. fahr. and "Extra Hecla" for over 600 deg. fahr. total temperature.

431. Operating Engines On Superheated Steam Does Not Necessarily Involve Any Change In Operating Methods. Engine valves and lubrication systems must be such as to permit the contemplated degree of superheat. *Metallic packing* (Fig. 369) should always be used with high-pressure superheated steam since soft packings will not stand the high temperatures and pressures. The packing gland should also be independently supplied with oil of a high grade and under pressure.

NOTE.—OIL IS SUPPLIED TO THE CYLINDERS AND VALVES OF COUNTERFLOW ENGINES EMPLOYING SUPERHEATED STEAM preferably by the atomization method, as explained in Sec. 502. However, oil is sometimes admitted through openings into the valve chest. The piston valve of Fig. 485 is supplied with oil through the lining around its central portion. The oil is led through a pipe to the small annular space between the two halves of the lining from which it is carried by the moving valve and later taken away by the steam. Uniflow engines are supplied with cylinder oil as explained in Sec. 434.

432. The Use Of Superheated Steam Partially Obviates The Desirability Of Compounding.—As was explained in Sec. 273, the chief purpose in compounding is to decrease cylinder condensation. When superheated steam is used,

its excess heat prevents any immediate condensation and may keep the steam dry until cut-off. Moreover, the lesser heat conductivity of superheated steam results in a lesser transfer of heat to and from the cylinder walls. Hence it follows that the economy of superheating (Figs. 487 and 488) is not as great in compound and triple-expansion engines as in

simple engines. Also the economy of compounding is not as great when superheated steam is used as when the steam is saturated. These facts are evident from the following table:

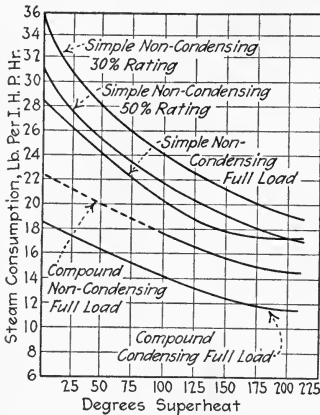

FIG. 487.—Showing the effect of superheat on a simple 12 by 16- and a compound 10 and 17½ by 16 in. piston-valve Buckeye engines. (Steam pressure 100–110 lb. per sq. in. Foster superheater catalogue.)

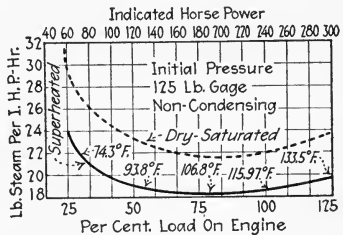

FIG. 488.—Graphs showing influence of superheat on water-rate (steam consumption) of a 16 by 22-inch "Ideal" Corliss engine.

433. Table Showing Savings Effected In Engines Of Different Classes By Superheating The Supply Steam. (Alexander Bradley, *Power*, Sept. 2, 1919.)

Engine	Saving in per cent. due to 100 deg. fahr. superheat at average pressures	
	Steam saving	Heat saving
Simple engines and compressors.....	18	13.5
Compound engines and compressors.....	14	10.5
Triple-expansion engines.....	12	9.0
Single direct-acting pumps.....	22	16.5
Compound direct-acting pumps.....	18	13.5

NOTE.—Compound and multi-expansion engines benefit more by higher steam pressures than they do by superheat. Consequently the practice is to use relatively high pressures and relatively little superheat with engines of these types.

434. In Uniflow Engines, The Use Of Superheated Steam Is Very Economical (Sec. 333). Uniflow engines are practically always simple engines but are installed where high economies are desired and are commonly operated condensing. Under these conditions, superheated steam is a decided advantage and is nearly always used.

NOTE.—IN LUBRICATING UNIFLOW-ENGINE CYLINDERS, it is better to inject some of the oil at points *A* and *B* (Fig. 489), than to mix it all with

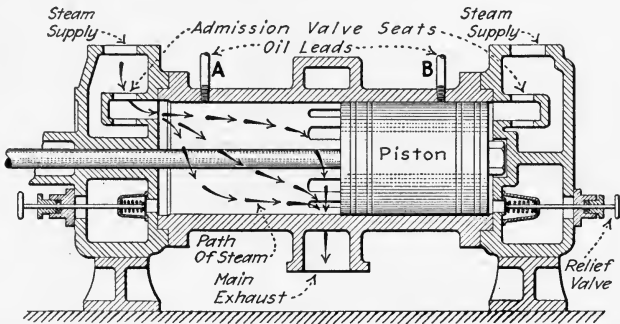

FIG. 489.—Showing recommended points of oil injection in uniflow engine. (Arrows show direction of steam flow.)

the steam. Due to the nearly straight path of the steam in a uniflow-engine cylinder, the oil which is mixed with the steam has much less tendency to attach itself to the walls of the cylinder than it has in counter-flow engines. However, when injected at *A* and *B*, the oil has a tendency to flow down over the walls. The piston then spreads it over the cylinder's length.

435. When Superheated Steam Is Used In Compound Or Triple-Expansion Engines, the steam usually becomes saturated in the high-pressure cylinder before release. Hence, the steam enters the receiver as wet steam. A reheater (Fig. 336) is frequently used under these conditions to superheat the steam again before it enters the next lower-pressure cylinder; see the "locomobile" in Fig. 395.

NOTE.—SIMPLE ENGINES ARE PROFITABLY OPERATED AT RELATIVELY LOW PRESSURES AND HIGH SUPERHEATS. For mechanical reasons high pressures are not desirable in simple engines. But, for high efficiency, the temperature range in a simple engine must be great. By employing high superheats, a large temperature range may be secured without the mechanical difficulties and excessive cylinder condensation (Fig. 490) which high pressures involve.

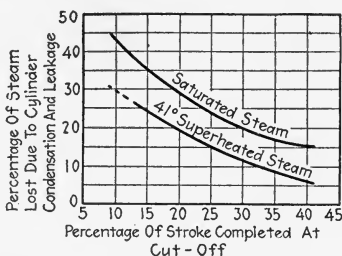

FIG. 490.—Graphs showing effect of superheated steam in decreasing cylinder condensation and leakage in simple engines. (An average of 41 deg. fahr. superheat.)

436. A Table Showing The Advantages And Disadvantages Of Superheated Steam as compared to saturated steam for steam-engine operation is as follows:

Advantages	Disadvantages
Increases engine efficiency. Decreases the amount of oil needed. Requires less weight of steam for a given amount of power.	Requires additional equipment. Requires a better grade of oil. Requires high-temperature packing.
Decreases cylinder condensation and trouble with water in engine cylinder.	Where impure feed water is used, dust may be carried from the superheater to the engine. See note below.
Decreases radiation and pressure losses.	May cause changes in shape and size of cast-iron parts.

NOTE.—A FOAMING BOILER MAY GIVE DANGEROUS RESULTS IF THE STEAM IS SUPERHEATED. The foam which leaves the boiler is usually a saturated solution of some mineral which was used as a scale preventive. When this saturated water is evaporated in a superheater, the mineral remains in the superheater as a fine dust. After a quantity of dust accumulates in the superheater, some of it will be carried away with the steam which passes to the engines. As this mineral dust is a very

good abrasive, it becomes very dangerous in that it will probably score the engine cylinder. Foaming of the boilers is, therefore, to be particularly avoided when the steam leaving the boiler is later superheated.

QUESTIONS ON DIVISION 14

1. What steam saving results from superheating steam for simple engines?
2. What effect has superheat on cylinder condensation?
3. Name six differences between superheated and saturated steam.
4. What is an approximate relation between the temperature of superheated steam and its volume?
5. What types of valves are preferred for highly superheated steam?
6. What effect in the valves of an engine is noticed due to the lesser fluid friction of superheated steam?
7. What is the approximate limit of total temperature for cast-iron valves?
8. What metals are used in valves for superheated steam?
9. What kinds of cylinder oil are recommended for engines using superheated steam?
10. How is oil introduced into a counterflow engine using superheated steam? Into a uniflow engine?
11. What kind of packing should be used for highly superheated steam?
12. What is the relation between compounding and superheating in steam-engine practice?
13. How does superheating lessen the desirability of compounding?
14. When, in general, are high pressures and slight superheats used? When low pressures and high superheats?
15. What is the usual condition of the exhaust steam from the high-pressure cylinder of a compound engine using superheated steam?
16. Enumerate the principal advantages of superheated steam for engines.
17. Explain why a foaming boiler is dangerous in a superheated-steam plant.

DIVISION 15

SELECTING AN ENGINE

437. The Governing Factor In Selecting An Engine Should Be The Cost Per Unit Of Energy Delivered by the engine. In computing the cost per unit of energy delivered (Sec. 447), all items of expense must be considered. An engine with a very low initial cost may, because of its steam rate, produce power at a much higher cost than a more expensive engine which uses less steam. Conversely, the engine which uses least steam—and therefore the least fuel—will not, necessarily, produce power more cheaply than a less expensive engine which uses more steam—although, erroneously, some engineers consider only the fuel cost. As explained in following sections, there are a large number of elements which enter into the computation of the unit energy cost. The unit energy cost is usually computed over a yearly period, thus:

$$(63) \text{ Cost per unit of energy} = \frac{\text{Total expenses per year}}{\text{Energy units developed per year}}$$

NOTE.—THE TOTAL ANNUAL COST OF AN ENGINE, which will supply a given quantity of power throughout the year and under certain conditions, is frequently used as the governing factor in selection; but, as explained later, the total annual cost then bears a given ratio to the unit power cost. Thus, it is immaterial whether, under given conditions, the unit energy cost or the total annual cost is taken as the governing factor in engine selection.

NOTE.—THE PROCEDURE IN SELECTING AN ENGINE FOR A GIVEN SERVICE consists of: (1) *A study of requirements and operating conditions* Sec. 448, to determine what type or types of engines are best suited for the service. (2) *A computation of the unit cost of energy for each engine which is suited for the service* and which it is desired to consider. (3) *A choice of the engine* which affords the least unit energy cost. The sections which immediately follow deal with the calculation of the true unit energy cost. After this are given considerations of service requirements and more specific rules for engine selection.

438. Various Elements Which Are Factors In Energy Cost And Which Should Be Considered In Computing The Cost Per Unit Of Energy are generally grouped into two classes: (1) *The fixed charges*, or those elements of cost which are the same whether an engine is operated or idle. The fixed charges, as explained in subsequent sections, comprise interest on invested capital, rentals, insurance, taxes, and depreciation, which is the natural loss of value of the machine as its age increases (Sec. 443). (2) *Operating charges*, or those elements of cost which are proportional, directly or otherwise, to the energy developed by an engine. The operating charges, as is also explained in subsequent sections, include the cost of all labor involved in the operation of the engine, the costs of all materials which are consumed in its operation, and all costs necessary to keep it in a good operating condition; such as the cost of repairs, replacements, and adjustments. These operating charges are frequently termed *attendance*, *material*, and *maintenance* respectively.

NOTE.—FIXED CHARGES ARE OFTEN COMPUTED AS A LUMP SUM—that is, the annual amount of the fixed charges is taken as a certain percentage of the total first cost. A common percentage for this purpose, which experience shows to be fairly accurate for *average* conditions, is 15 per cent. Thus, if an engine, installed, costs \$10,000, the fixed charges may be taken as $0.15 \times \$10,000 = \1500 per year. Why 15 per cent. is taken rather than some other value will be evident from a study of the example under Sec. 446 wherein the total of the fixed-charge percentages is 15.

439. Interest is the cost of the capital—invested money—in any undertaking. Interest is a rental or fee paid for the use of money. A corporation can only obtain money by borrowing from investors who always demand interest (a rental) in payment for use of the money. If the borrowed money is used to purchase an engine, the interest on the invested money is an item of the expense incurred in operating the engine. Now, even if one uses his own money—and does not have to borrow—in purchasing an engine, interest should nevertheless be charged in when determining the total expenses per year of the engine. One must consider that, if the engine had not been purchased, the money which was used for its

purchase could have been invested, kept on deposit, or loaned so as to draw interest. If the money is invested in an engine it should bring at least the same return. Therefore, for comparative purposes the interest on the money invested in the engine should always be computed and recognized as an item of expense incident to the ownership of the engine. See example under Sec. 446 for an application of this idea.

NOTE.—THE ANNUAL INTEREST EXPENSE is determined by the amount of the initial investment and by the current interest rate. The initial investment includes the first cost of the engine, its accessories, foundation, and installation together with all transportation charges. The interest rate is usually 6 to 8 per cent. per year.

EXAMPLE.—If an engine installed complete costs \$10,000 and the usual interest rate in the community where it is installed is 6 per cent.; then *the annual interest expense of operating the engine* = $10,000 \times 0.06 = \$600$ per year—and this \$600 is just as real an item of the cost of running the engine as is the cost of the oil and waste for it or the cost of the steam which operates it.

440. Rent, As An Item Of Engine Expense, Should Be Charged In Proportion To The Floor Space occupied by an engine whether the building in which the engine is housed is rented or not. The engine and its accessories occupy space which could otherwise be used for some other purpose. The fair rent which this space could command is justly an expense incident to the keeping of the engine. Horizontal engines occupy space about as follows: Over 2000 h.p.—0.5 sq. ft. per h.p.; 500 to 1000 h.p.—1 to 2 sq. ft. per h.p. Small engines—3 to 4 sq. ft. per h.p.

NOTE.—A PORTION OF THE ADMINISTRATION OR OFFICE EXPENSE OF A PLANT may be charged to an engine, according to its value as compared with that of the rest of the plant. It may, however, be advisable to group the engine administration expense with that of the rest of the power-plant equipment and then, for cost-estimating purposes, to handle this combined item as a single item.

441. Insurance Cost Is An Item Of Engine Expense because it is a direct expenditure for protection against loss by fire or other hazards. The annual cost of insurance against fire loss is small. In a fireproof building it is ordinarily less than 0.5 per cent. annually of the amount of insurance carried. In

wooden buildings it is somewhat greater. An average value is about 1.5 to 2 per cent. In hazardous locations, such as in a saw mill where the fire risk is great, it may be impossible to get any insurance. The *depreciation rate* (Sec. 444) should then be made high enough to cover a possible loss by fire within a few years.

442. Taxes Constitute An Item Of Engine Expense because taxes are the cost of government, including police and fire protection, which is levied on all property in proportion to its assessed value. Tax rates per year are usually 1 to 2 per cent. annually of the assessed value of the property. The assessed value is generally lower by a considerable amount than the first cost. The actual tax rate for any community may be ascertained by consulting the assessor. After the tax rate is determined, the taxes on the engine should be included in its annual expense. Taxes on the real estate on and in which the engine is housed should be taken account of in computing the rental (Sec. 440) and should not be included as a direct engine expense under the heading of taxes.

443. Depreciation is the decrease in value of a thing as it becomes older. Any piece of machinery has a certain useful life. If a thing has a life of 10 years and no scrap value and its original cost is \$100, it is evident that (disregarding interest on sinking fund and other refinements) the *cost per year of its decrease in value* = $\$100 \div 10 = \10 . From this it is evident that depreciation is a reasonably definite and tangible item in the cost of operating an engine. Depreciation may be due to: (1) *Wear and tear*; continual use gradually produces wear at all of an engine's bearing surfaces. Eventually it may be impossible to properly adjust the worn parts. The engine will then be useless. (2) *Obsolescence*; improvements are being made continually in the principles and construction of steam engines. It may therefore be assumed that, even if it were possible to maintain an engine indefinitely in good running order, the engine would eventually have to be replaced by some more efficient engine. As an example of obsolescence may be taken the case of many good steam engines which were in use when the steam turbine was first perfected. In many instances, the engines were so much less efficient than

turbines that, though new, it would have paid to replace them with turbines. (3) *Inadequacy*; in many plants the demands for power increase to such an extent that it becomes economically wise to discard old but mechanically good engines in favor of larger engines. Customarily, it is not attempted to foretell whether an engine will depreciate because of wear and tear, obsolescence, or inadequacy; but, instead, a useful life is assumed in accordance with the lives which experience shows to be most common; see following section.

NOTE.—THE “DEPRECIATION CHARGE” OR “COST” OR THE “ANNUAL DEPRECIATION” is the amount which should be considered as an annual expense incident to the ownership of an engine (or other equipment). It may be found by dividing the first cost of the engine by its useful life in years. It should be understood that annual depreciation charges can be only reasonably accurate estimates or guesses—it is impossible to predetermine depreciation exactly. The depreciation charge should actually be paid out—that is, it should be placed in a bank or other safe depository. The sum which thus accumulates in the depository is called the *sinking fund*. At the end of the engine’s useful life the sinking fund should equal the first cost of the engine so that the engine may be replaced without borrowing new capital or, if the engine is no longer needed, that the investors may be paid off. To be strictly correct it might seem that, since the sinking fund can be made to draw interest and since at the end of its useful life the engine still has some value (see below), the depreciation charge computed as directed above will provide a sinking fund which will exceed the engine’s true depreciation. But, since the life of the engine is not definitely known beforehand, the “straight-line” method of computing the depreciation charge, which is suggested above, is sufficiently accurate for practical purposes.

NOTE.—THE RESIDUAL VALUE OR SCRAP VALUE OF AN ENGINE is its value at the end of its useful life. Since, at the end of its useful life, an engine has no value as an engine, its residual value is simply the value, as scrap, of the materials of which it is made. The residual value of an engine seldom exceeds 5 per cent. of its first cost.

444. The Usual Depreciation Rates For Steam Engines are determined from their useful lives. Experience shows that the average lives of steam engines are about as follows: *High-speed engines*—17 years. *Medium-speed engines*—20 years. *Low-speed engines*—28 years.

EXAMPLE.—If the first cost of a medium-speed engine is \$8000 what should be its annual depreciation cost? SOLUTION.—Since the probable

life of a medium-speed engine is 20 years, the *depreciation rate* = $100 \div 20 = 5$ per cent. Therefore, the *annual depreciation cost* = $0.05 \times \$8000 = \400 .

445. The Operating Costs Of An Engine are: (1) *Maintenance*, which comprises the costs of repairs and such replacements of parts as are occasionally necessary. The maintenance cost per year may ordinarily, for estimating purposes, be taken at 2 to 4 per cent. of the first cost of the engine. (2) *Materials*. These are steam, engine oil, cylinder oil, packings, waste, and miscellaneous supplies. *The cost of steam* varies

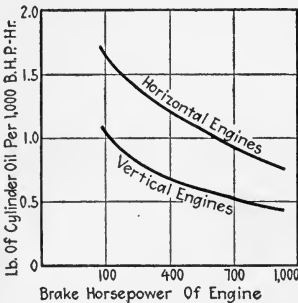

greatly with boiler conditions and the price and kind of fuel. With 12,000 B.t.u. coal at \$5.00 per ton, the average cost of producing steam in a stoker-fired water-tube boiler plant is about 45 ct. per 1000 lb. For the same coal in a hand-fired return-tubular plant, the cost would be about 60 ct. per 1000 lb. In any plant, *the cost of steam per pound* = $(\text{total annual boiler-plant expense}) \div (\text{number of pounds of steam generated per year})$; see the author's STEAM BOILERS. *The cost of cylinder oil* may be based on the average cylinder-oil consumptions shown on the graph of Fig. 491. The amount of engine oil used varies greatly with the method of lubrication and the precautions taken for its recovery. It should not greatly exceed the amount of cylinder oil. *The cost of the other materials* seldom exceeds 10 ct. per h.p. year for a 100-h.p. engine to 2 ct. per h.p. year for a 1000-h.p. engine. In general, the oil and other supplies constitute about 2 to 9 per cent. of the total operating expenses. (3) *Attendance*. This includes the salaries of operating engineers, oilers, and a portion of the salaries of superintendents and others who devote part of their time to the engine or in supervising its attendants. An operating engineer can, ordinarily, take care of more than one engine; but, where the plant is operated 24 hours per day, three engineers are probably necessary.

446. The Total Annual Cost Of An Engine is the sum of the annual fixed and operating costs. The meaning of this is illustrated in the following example which gives an economic comparison between engines of two different types which are to be served by an existing boiler plant.

EXAMPLE.—Compare the annual cost of a poppet-valve engine with that of a slide-valve engine. Both are rated at 200 h.p. and both are operated non-condensing on saturated steam. The poppet-valve engine uses 18 lb. of steam per i.h.p. hr. at 175 lb. per sq. in.; the slide-valve engine uses 29 lb. of steam per i.h.p. hr. at 125 lb. per sq. in. Assume that the cost of the steam at 175 lb. per sq. in. is 51 ct. per 1000 lb., and at 125 lb. per sq. in. is 50 ct. per 1000 lb. A stand-by unit is assumed to be necessary in each case.

SOLUTION.—

Fixed charges:

	POPPET- VALVE	SLIDE- VALVE	POPPET- VALVE	SLIDE- VALVE
First cost of one engine.....	\$4,175	\$2,225	\$
Foundation and installation.....	625	625
<hr/>				
Total first cost.....	\$4,800	\$2,850
Interest at 6 per cent.....			\$ 288	\$ 171
Depreciation based on an 18-year life at 5.55 per cent. (100 ÷ 18 = 5.55 per cent. per year).....			266	158
Rent.....			70	60
Taxes and insurance at 2 per cent.....			96	57
<hr/>				
Total fixed charges.....			720	446
<hr/>				
Doubling this value to include stand-by unit.....			1,440	892
<hr/>				
<i>Operating charges</i> (assuming 700,000 i.h.p. hr. of service per year, that is 200 h.p. delivered 10 hours per day for 350 days):				
Steam, 12,600,000 lb. at 51 ct. per 1000 lb.....			6,426	
20,300,000 lb. at 50 ct. per 1000 lb.....				10,150
Oil and other supplies.....			255	255
Attendance.....			3,150	3,150
Repairs (guess estimate).....			115	95
<hr/>				
Total operating charges.....			9,946	13,650
<hr/>				
Total annual cost.....			\$11,386	14,542
				11,386
<hr/>				
Annual saving of poppet-over slide-valve engine.....				\$ 3,156

The obvious conclusion is that, for the conditions specified, the poppet-valve engine is the more economical. This is because of its lower steam consumption. If the steam (coal) were cheaper or if the engine were used fewer hours during the year, the difference in the annual costs would be less than \$3156 or it might be in favor of the slide-valve engine. It would be possible to decrease the initial investment for the poppet-valve engines by using a cheap engine as a stand-by unit. The standby unit need not, ordinarily, be operated more than a week in each year; hence its steam consumption would be of relatively minor importance. There are, however, many advantages in having both the working and spare engines of the same kind (Sec. 452).

447. The Unit Cost Of The Energy which is generated by an engine is calculated by dividing the total annual cost of an engine by its yearly energy output; see Sec. 437 and also the following example.

EXAMPLE.—If the engine of the preceding section produces annually 650,000 h.p. hr. of useful mechanical energy, would it be as cheap to buy electrical energy (which can be converted into mechanical with an efficiency of 82 per cent.) for 4 ct. per kw. hr.? SOLUTION.—The cost of the purchased mechanical energy (converted electrical energy) is $4 \div 0.82 = 4.9$ ct. per kw. hr. From the engine, the *mechanical energy cost* = (total annual cost) \div (number of energy units produced) = $\$11,386 \div 650,000 = \0.0175 or 1.75 ct. per h.p. hr. or $1.75 \times 1000/746 = 2.35$ ct. per kw. hr. Therefore, the engine develops energy at a lower cost than that for which the electrical energy can be bought.

448. Before Endeavoring To Select An Engine For Any Given Service, the following factors should be determined or estimated: (1) *Horse power of engine.* (2) *Speed of engine.* (3) *Operating conditions*, such as the initial state—pressure and temperature—of the engine's steam supply, whether the engine is to be operated condensing or non-condensing, the boiler capacity, and the cost of fuel. If the engine is to run non-condensing and if exhaust steam is necessary for heating or industrial processes, the quantity of exhaust steam required should also be known. (4) *Operating characteristics*, such as the load curve (see Sec. 453), the expected life of the engine, and the types of the other engines in the plant.

NOTE.—IN SELECTING ENGINES FOR A NEW PLANT the operating conditions are not usually determined definitely until after the type of engine which will be used has been selected. Furthermore, the requirements, as to horse power and exhaust steam required, can frequently be

only estimated. However, in selecting an engine for addition to an existing plant, the requirements and operating conditions are usually better known.

449. In Determining the Proper Horse Power Of A Contemplated Engine two things should be considered: (1) *The maximum or peak load* which the engine must carry. As engines cannot economically develop much more than 25 per cent. overload and as it may be expected that the power requirements will usually increase after the engine is in service, the engine selected should have a normal rated capacity at least as great as the peak load which it must carry. (2) *The continuity of service* which is desired. In some plants the management will not object to an occasional shut-down of the engines for repairs. During the shut-down power may, in some cases, be purchased from another company. In other plants, electric-light plants in particular, there must be no danger of having ever to discontinue any of the power supply. In such plants the units should be so selected that, should the largest unit need repair, the remaining units can carry the entire load which may come on the plant.

EXAMPLE.—If a power plant has a peak load of 400 h.p., and if shut-downs are permissible, the plant may be equipped with one 400-h.p. engine or two 200-h.p. engines; but, if shut-downs must be avoided, the plant must either have two 400-h.p. engines or three 200-h.p. engines, or some other combination, see Sec. 453.

450. In Determining The Desirable Speed Of A Contemplated Engine Or Engines, the use to which the engine is to be put should be considered. Generally speaking, electric generators, especially alternating-current generators, are most advantageously driven at high rotative speeds because high-speed generators cost less than do slow-speed generators. High-speed engines may, therefore, be direct-connected to generators whereas slow-speed engines must be belted to or employ larger and more expensive generators. Where engines are not used to drive generators, the service conditions almost automatically determine the most desirable speed. In any case, the desirability of a certain engine speed should be considered along with all other factors. When an engine is belted to its load the ratio of the speeds of the driving to the

driven pulley or vice versa should not exceed 6 to 1; 4 or 5 to 1 is preferable.

NOTE.—THE SPEED OF AN ENGINE WHICH DRIVES A DIRECT-CONNECTED ALTERNATING-CURRENT GENERATOR is definitely determined by the desired frequency and the number of field poles of the generator, thus:

$$(64) \quad r. p. m. = \frac{120 \times \text{frequency}}{\text{No. of field poles}}$$

See the author's AMERICAN ELECTRICIANS' HANDBOOK for further information and table of *synchronous speeds* for the various frequencies and numbers of field poles.

451. In Considering The Operating Conditions With Reference To The Selection Of A Contemplated Engine Or Engines it should be remembered that: (1) *The state of the steam supplied to the engine* determines to a degree the kind of valves which the engine may have; see Sec. 428. (2) *Exhaust steam requirements*, throughout the factory, determine whether a low steam rate is necessary or even desirable. (3) *Condensing operation* is advisable under certain conditions (see Sec. 297), but, in other cases, is not necessary or even desirable. (4) *Boiler and condenser capacities* determine whether the contemplated engines will necessitate new boilers and condensers and, therefore, additional investment. Sometimes an engine with a small water rate can be installed without any increase in boiler or condenser capacity, whereas a cheaper engine, which would otherwise be satisfactory, would require the purchase of additional equipment because of its higher water rate. (5) *Fuel cost* determines whether a low-water-rate engine is economically preferable for a given service. Where fuel is very cheap, as in saw mills and coal mines, the higher first cost of an economical engine may not be justified by the small fuel saving.

NOTE.—IN SELECTING THE PROPER BOILER PRESSURE FOR A NEW PLANT, the soundest plan is to find the unit cost of energy (Sec. 447) for different assumed boiler pressures and the correspondingly different engines and boilers. That pressure is then chosen which provides the least unit cost. Generally speaking, high-pressure boilers are more expensive in fixed and operating costs than are low-pressure boilers. Nevertheless, engines operated on high-pressure steam are always more efficient than those operated on low-pressure steam and, usually, the

fixed charges are less for the engine which is operated on high-pressure steam. The boiler pressure should therefore be *as high as is practical* with the engine which is best suited to the plant; maximum permissible pressures and superheats for the engines of the different types are given in Table 428.

452. The Operating Characteristics Which Affect The Selection Of An Engine are: (1) *The load curve of the plant* (Fig. 492). The load curve of the plant is the graph which shows the variation from time to time of the required total engine output.

A load curve might be plotted for any particular engine; from this graph can be read the portion of the total time that the engine must carry its rated full load and other fractional loads. These portions of time determine to a large extent whether the engine should have good economy or not. For example, if an engine is to be operated a great portion of the time at only one-fourth its rated capacity, then it should be selected on the basis of its steam rate at one-fourth load rather than the basis of its full-load steam rate. Likewise, if an engine is to stand idle for a great portion of the time, since its fixed charges continue while it is not in operation, the operating charges may constitute but a small fraction of its total annual cost; hence its water rate is of relatively little importance. (2) *The life of the engine*. If an engine is to be used continuously, its life will of course be shorter than if it were used but little. However, the life of an engine is frequently assumed to be the same regardless of its service because it gradually becomes useless although it may not be wearing out, see Sec. 443. (3) *Other engines in the plant*. If a plant is already equipped with some engines, additional engines which are to be installed should, unless some other consideration is more important, be of the same make and kind as the older engines. This will insure a better understanding of all engines and, if the new and old engines are exactly alike,

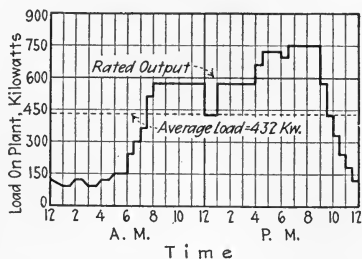

FIG. 492.—Daily load curve for a 600-kw. electric power plant.

a reduction in the number of repair parts which must be stocked.

NOTE.—THE “LOAD FACTOR” OF A PLANT may be taken as the ratio of its daily average power output to the maximum load which it must carry. The daily average power output is found by first computing the total daily energy output (kw. hr. or h.p. hr.) and then dividing this value by the number of hours in the day. Stated as an equation:

$$(65) \quad \text{Load factor} = \frac{\text{Average power output}}{\text{Maximum power output}}$$

EXAMPLE.—If, in Fig. 492, the average power output is found to be 432 kw., what is the load factor? SOLUTION.—Since, in Fig. 492, the maximum load on the plant is 750 kw., $\text{load factor} = 432/750 = 0.58$ or 58 per cent.

453. Engine Sizes Should Be Selected To Suit The Load Curve, where such procedure is economically feasible. Especially in large plants, where a number of engines are required to carry the maximum power output, the engines may be so selected as to size that at no time is any engine operating at a small fraction of its rated load. This can best be illustrated by an example.

EXAMPLE.—Let graph A, Fig. 493, represent the load curve of a contemplated plant. It is desired to equip the plant with engines to suit the load curve. It is evident that, from midnight to 5 a.m., a 500-h.p. engine will carry the load. It is also evident that, from 8 a.m. to 5 p.m., the load can be carried by engines aggregating 2500 h.p., whereas the maximum load during the day, which occurs in the evening, can be carried by 3000 h.p. of engines. Suppose, then, that the plant will be equipped with the following engines: One 500-h.p., one 1000-h.p., and two 1500-h.p. (one as a stand-by or emergency engine). Then the load can be carried thus: From midnight to 5 a.m. only the 500-h.p. engine need be operated. From 5 a.m. to 8 a.m. only one 1500-h.p. engine will be needed. From 8 a.m. to 5 p.m. one 1500-h.p. and the 1000-h.p. engine can be used. From 5 p.m. to 10 p.m. the two 1500-h.p. or one 1500-h.p. together with the two smaller engines will carry the load. From 10 to 11 p.m. one 1500- and the 500-h.p. engine will

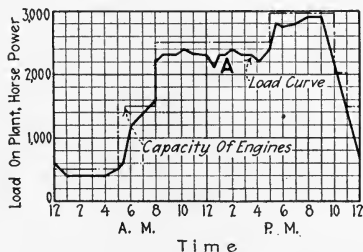

FIG. 493.—Showing method of operating engines to conform to the load curve in a large plant.

suffice: At 11 p.m. the 500-h.p. one can be stopped, the load until midnight being carried by the large engine. Thus, at no time is any engine operated under a small fractional load. Still, the plant can be operated at all times with any unit out of service.

454. The Selection Of An Engine For A Given Service involves a computation of the unit energy costs for those various engines which seem to suit the plant requirements with regard to horse power, speed, operating conditions and plant characteristics, as these requirements are outlined in

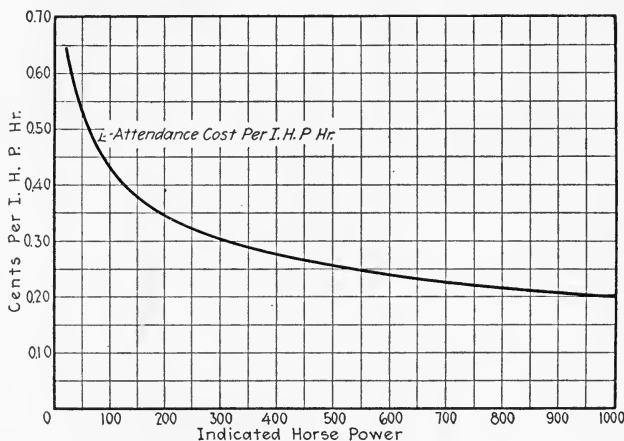

FIG. 494.—Approximate attendance costs for steam engines.

the preceding sections. After the unit energy costs of the various engines have been computed (or their annual costs, see example under Sec. 446), the selection can be readily made. In making rough estimates as to engine cost, the data given in Sec. 338 will be found valuable. The water rates of engines as given in Div. 11 will also be found useful in estimating operating costs. Attendance costs may be taken from Fig. 494 or from a similar graph.

455. A Useful Chart For Selecting An Engine is shown in Fig. 495. Each black space in the chart indicates that the type of engine on that line is not well suited to the condition of its vertical column. A shaded (cross-sectioned) space indicates that the engine type of that line is sometimes used

for the condition of that vertical column. White spaces

	HORSE POWER					SPEED		LOAD FACTOR		SUPPLY STEAM PRESSURE		EXHAUST STEAM REQUIRED		BOILER CAPACITY	FUEL		EXHAUST		
	0-100	100-800	800-1200	1200-3000	OVER 3000	LOW	HIGH	LOW	HIGH	SUPER.	SATUR.	MUCH	LITTLE	NONE	APPLE	SCANT	EXPENSIVE	ATMOSPHERIC	CONDENSER
	OVER 150 LB.	UNDER 150 LB.	OVER 150 LB.	UNDER 150 LB.	MUCH	LITTLE	NONE	APPLE	SCANT	EXPENSIVE	ATMOSPHERIC	CONDENSER							
SIMPLE SINGLE VALVE																			
COMPOUND SINGLE VALVE																			
CORLISS NON-RELEASING SIMPLE																			
CORLISS DETACHING SIMPLE																			
PISTON 4-VALVE SIMPLE																			
POPPET 4-VALVE SIMPLE																			
CORLISS NON-RELEASING COMPOUND																			
CORLISS DETACHING COMPOUND																			
PISTON 4-VALVE COMPOUND																			
POPPET 4-VALVE COMPOUND																			
NON-CONDENSING UNIFLOW																			
CONDENSING UNIFLOW																			
LOCOMOBILE																			

FIG. 495.—Engine-selection chart. To use, place a strip of paper under the column heading as shown in Fig. 496 and make marks in the proper places under each of the eight headings. Then slide down the paper until a line is found where no black spaces appear before the marks. A line in which no shaded or black spaces appear before the marks will indicate an engine which, if desirable, may be used. A line in which black spaces appear indicates an engine which is not well suited. See also Sec. 455.

indicate good practice. It is to be remembered that such a

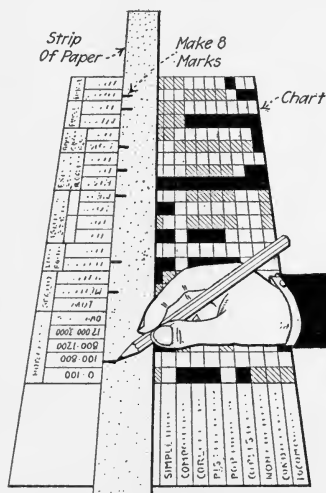

FIG. 496.—Illustrating method of using the engine selection chart of Fig. 495.

chart can only be an aid in selecting an engine and should not be relied upon to give the final choice. The final choice should in all cases be made only after a careful study of unit energy costs for the different engines (Sec. 454) which may be employed for the condition which is under consideration. Fig. 496 shows how to use the chart.

456. Steam-Engine Performance Guarantees (Fig. 497) are usually included with the specifications which manufacturers submit with their price proposals for high-grade

engines. The performance guarantees, when written or printed

ALLIS-CHALMERS MANUFACTURING COMPANY
MILWAUKEE, WISCONSIN, U. S. A.
SPECIFICATIONS FOR
ALLIS-CHALMERS HORIZONTAL SIMPLE CORLISS ENGINE

For United States Mfg. Company.

These specifications form part of proposal dated January 1st, 1922.

Cylinder diameter 12 inches, stroke 24 inches.
Revolutions per minute 150
Steam pressure at throttle valve 150 pounds gauge.
Superheat at throttle valve Zero degrees Fah. above temperature of saturated steam.
Back pressure at exhaust nozzle 1½ pounds gauge.
Vacuum at exhaust nozzle Non-Condensing inches of mercury, (Referred to 30"
Barometer)
Engine to be designed to operate (Condensing or Non-condensing) Non-Condensing
Engine to be (Right or Left) Left hand.
Direction of rotation of wheel (Over or Under) Under
Direction of drive (Away from or Back by cylinders) Away
Crosshead Pin, diameter 3½ inches, length 4½ inches.
Crank Pin, diameter 4½ inches, length 3½ inches.
Main Bearing, diameter 7 inches, length 14 inches.
Back Bearing, diameter 7 inches, length 13 inches.
Wheel, diameter 10 feet. Approximate weight 6900 pounds.
Wheel face 21 inches. Type of wheel (Belt, Rope or Square rim) Belt
Wheel to be crowned for belt of following width. 18"
Wheel to be grooved for _____ ropes _____ inches diameter.
Weight of heaviest piece of engine, approximately 4900 pounds.
(Exclusive of wheel)
Width and Height of largest piece of engine, approximately 33 inches x 35 inches.
(Exclusive of wheel)
Service (What will the engine drive and how will it be connected?)
Belted to Line Shaft

If the engine is to drive an electric generator the following blanks must be filled in.

GENERATOR _____ Kilowatts at _____ % Power Factor (_____ K. V. A.)
_____ Current, _____ Cycles, _____ Phase, _____ Volts, _____ R. P. M.

Is parallel operation required _____
Generator will be furnished by _____
Exciter will be furnished by _____
How is exciter to be driven _____

STEAM CONSUMPTION—This unit when operating under conditions stated on Page 5 of these specifications will require not to exceed the following pounds of steam per hour:

	LOAD	POUNDS STEAM
Full Load	<u>250</u> 250 I. H. P.	<u>21.8</u> 21.8 Per 250 I. H. P.
Three-quarter Load	<u>187</u> 187 I. H. P.	<u>20.6</u> 20.6 Per 187 I. H. P.
One-half Load	<u>125</u> 125 I. H. P.	<u>22.1</u> 22.1 Per 125 I. H. P.

A tolerance of 2% from figures given must be allowed for errors in observation and measurements.

FIG. 497.—Manufacturer's typical performance specifications for a simple non-condensing Corliss engine.

ALLIS-CHALMERS MANUFACTURING COMPANY

MILWAUKEE, WISCONSIN, U. S. A.

SPECIFICATIONS FOR ALLIS-CHALMERS HORIZONTAL CROSS COMPOUND CORLISS ENGINE

For Smith and Jones Manufacturing Company.

These specifications form part of proposal dated February 1st, 1922.

High pressure cylinder, diameter.....16.....inches, stroke.....36.....inches.
 Low pressure cylinder, diameter.....32.....inches, stroke.....36.....inches.
 Revolutions per minute.....120
 Steam pressure at throttle valve.....150.....pounds gauge
 Superheat at throttle valve.....100.....degrees Fah. above temperature of saturated steam.
 Back pressure at low pressure exhaust nozzle.....Condensing.....pounds gauge.
 Vacuum at low pressure exhaust nozzle.....26.....inches of mercury. (Referred to 30" Barometer)
 Engine to be designed to operate (Condensing or Non-condensing).....Condensing
 High pressure side to be (Right or Left).....Right.....hand.
 Direction of rotation of wheel (Over or Under).....Over
 Direction of drive (Away from or Back by cylinders).....
 Crosshead Pins, diameter.....4½.....inches, length.....6.....inches.
 Crank Pins, diameter.....6.....inches, length.....5.....inches.
 Main Bearings, diameter.....14.....inches, length.....20.....inches.
 Wheel, diameter.....14.....feet. Approximate weight.....22000.....pounds.
 Wheel face.....inches. Type of wheel (Belt, Rope or Square rim).....Square rim
 Wheel to be crowned for belt of following width.....
 Wheel to be grooved for.....ropes.....inches diameter.
 Weight of heaviest piece of engine, approximately.....10000.....pounds.
 (Exclusive of wheel)
 Width and Height of largest piece of engine, approximately.....48.....inches x.....48.....inches.
 (Exclusive of wheel)
 Service (What will the engine drive and how will it be connected?).....
Direct connected to 500 KVA. alternating current generator.

If the engine is to drive an electric generator the following blanks must be filled in.

GENERATOR.....400.....Kilowatts at.....80.....% Power Factor (.....500.....K. V. A.)
 Alternating Current,.....60.....Cycles,.....3.....Phase,.....480.....Volts,.....120.....R. P. M.

Is parallel operation required.....Yes

Generator will be furnished by.....This company

Exciter will be furnished by.....This company

How is exciter to be driven.....Belted to pulley on engine shaft

STEAM CONSUMPTION—This unit when operating under conditions stated on Page 5 of these specifications will require not to exceed the following pounds of steam per hour:

	LOAD		POUNDS STEAM
Full Load	400 (640)	K. W.-(I. H. P.)	20.5 (12.8) Per K. W.-(I. H. P.)
Three-quarter Load	300 (493)	K. W.-(I. H. P.)	21.0 (12.7) Per K. W.-(I. H. P.)
One-half Load	200 (350)	K. W.-(I. H. P.)	23.5 (13.5) Per K. W.-(I. H. P.)

NOTE—A tolerance of 2% from figures given must be allowed for errors in observation and measurements.

Fig. 497A.—Manufacturer's typical performance specification for a cross-compound condensing Corliss engine direct connected to an alternating-current generator. (Although in the above specification the water rate is given both in lb. of steam per kw. hr. and in lb. of steam per i.h.p. hr., manufacturers will ordinarily make guarantees on only one—not both—of these two bases. It will be noted that the ratio of the steam rates based on kw. hr. and on i.h.p. hr. involves the efficiency of the engine (mechanical) and generator, which in this case is about 83 per cent.)

in specification form, constitute what is called a *performance specification*. In a performance guarantee, a manufacturer will usually agree that, under certain operating conditions, his engine will have certain water rates at full load and at certain fractional loads. The graphs of Fig. 498 represent a manufacturer's guarantees. The purchaser may, in the contract, demand that, if the guarantees are not fulfilled in an *acceptance test*, either he will not accept the engine or that the price shall be proportionately decreased to penalize the manufacturer for failing to meet his guarantee. If a penalty is stipulated, the manufacturer will often demand (and is entitled to) a proportionate bonus or increase in price if the acceptance test should show better results than were specified in the guarantee.

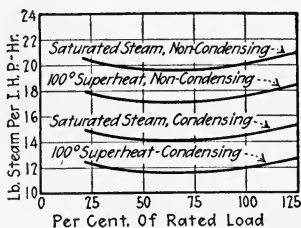

FIG. 498.—Manufacturer's guarantees for a uniflow engine which is to operate on steam at 150 lb. per sq. in. gage, exhausting, when non-condensing, against no back pressure and when condensing into a 26-in. vacuum.

NOTE.—THE ACCEPTANCE TEST may be conducted in the manufacturer's factory in the presence of the purchaser's representative, or after the engine is erected in the purchaser's plant. If there should be any doubt of obtaining the specified operating conditions during the acceptance test, the contract may be made to include the basis of correcting the test results to the specified conditions. To insure that the corrections will be properly made, manufacturers frequently are required to state their guarantees for a wide variety of operating conditions of which one is certain to approximate the expected conditions of the test.

NOTE.—TO CORRECT TEST RESULTS TO STANDARD OR SPECIFIED CONDITIONS—see following illustrative example—the following approximate rules may be used: (1) For each pound difference in initial pressure, correct the steam consumption by from 0.1 to 0.2 per cent. (2) For each 10 deg. of superheat, up to 100 deg. of superheat, correct the steam consumption by 1 per cent. (3) For each inch of vacuum, between 24 and 28 in. of mercury, correct the steam consumption by 0.5 per cent.

EXAMPLE.—An engine acceptance test shows a steam consumption at $\frac{3}{4}$ load of 22 lb. per i.h.p. hr. The actual operating conditions were: Steam pressure 160 lb. per sq. in.; superheat 50 deg. fahr.; vacuum 27 in. of mercury. What would be the approximate steam consumption at the same load ($\frac{3}{4}$ load) with steam at 175 lb. per sq. in., superheated

75 deg. Fahr., and with a vacuum of 25 in. of mercury? SOLUTION.—Applying a correction of 0.15 per cent. for each pound of pressure: *Correction for pressure* = $0.15 \times (175 - 160) = 2.25$ per cent. *Superheat correction* = $1 \times (75 - 50)/10 = 2.5$ per cent. *Vacuum correction* = $0.5 \times (27 - 25) = 1$ per cent. Now, since steam consumption decreases with increased pressure, higher superheat, and increased vacuum, the *net correction* = $1 - 2.5 - 2.25 = -3.75$ per cent. Or, the *required steam consumption* = $22 - (0.0375 \times 22) = 21.2$ lb. per i.h.p. hr.

457. Things Which Should Be Specified When Requesting A Quotation On A Steam Engine are as follows: (1) *Size*—give bore and stroke desired or horse power required. (2) *Type*—vertical or horizontal; simple, tandem- or cross-compound; uniflow or counterflow; center crank or side crank; if side

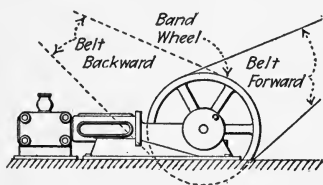

FIG. 499.—Illustrating meaning of "belt forward" and "belt backward."

crank, whether right hand or left hand. (3) *Speed*—normal speed or limits between which speed must be varied. (4) *Steam pressure* (and superheat if any) upon which the engine is to be operated. (5) *Governor*—throttling or cut-off. (6)

Valve type—whether slide, piston, Corliss or poppet. (7) *Back pressure* or *condenser vacuum* which will be maintained. (8) *Water rates* desired at full load and at fractional loads. (9) *Speed regulation*—allowable variation in speed from full load to no load due to sudden or gradual changes in load. (10) *Drive*—whether by belt, rope, or direct-connection. (11) *To run over or under*. (12) *Belt or rope forward or backward* (Fig. 499)—if for belt or rope drive. (13) *Foundation plan*—if space is restricted specify space limits. (14) *Base*—whether desired or not. (15) *Accessories* desired with engine—electric generator, condenser, lubrication system, foundation anchor bolts, etc. (16) *Freight*—state whether manufacturer shall pay freight.

NOTE.—IF AN ELECTRIC GENERATOR IS TO BE FURNISHED WITH THE ENGINE, the generator should be fully specified. The voltage, load characteristics, number of phases and wires, frequency, method of excitation, whether exciter and exciter belt and pulleys are to be furnished, and other electrical accessories which are required should be specified.

NOTE.—IF A PUMPING ENGINE IS TO BE FURNISHED, the capacity, discharge pressure, suction head, and pipe sizes should also be specified.

QUESTIONS ON DIVISION 15

1. What factor should form the basis upon which engines are selected? Define *cost per unit of energy*.
2. Define *fixed charges*. Tell what costs are considered as fixed charges?
3. Define *operating charges*. What costs constitute operating charges?
4. By what approximate rule may fixed charges be computed? What percentage of the first cost are the fixed charges in the example of Sec. 446?
5. Why must interest be considered as a fixed charge? What rate is usually used?
6. Why must rent be always considered as a fixed charge? If a company owns its own power plant building, how is the rental charge justified?
7. How may insurance and tax rates be determined?
8. Explain fully why depreciation must be considered as a fixed charge. What is a *sinking fund*?
9. What are the customary depreciation rates for steam engines? Explain the use of a sinking fund table. What is the *straight line* method of computing depreciation?
10. List all the operating costs of a steam engine. Which of these is usually the largest?
11. Define *total annual cost*. How is it related to the cost per unit of energy?
12. Explain fully how the horse power of a contemplated engine is decided upon.
13. What consideration must be given to engine speed when making a selection? Why?
14. What influence do operating conditions have on the selection of an engine? Explain fully and give the reasons.
15. What operating characteristics must be considered in selecting an engine? How do they affect the unit cost of energy?
16. Explain the use of the chart of Fig. 495 for selecting an engine. Does the chart afford an accurate means for making a wise selection? Why?
17. What are *performance guarantees*? What is a *performance specification*? How are they useful?
18. How may performance guarantees be corrected to different operating conditions than those of the test?
19. Write a sample letter requesting a quotation on an engine, giving all information it may be desirable for the manufacturer to know.

PROBLEMS ON DIVISION 15

1. An engine has a constant load of 250 h.p. for 10 hours per day and 300 days of the year. If its total cost for the year is \$15,000, what is the cost per unit of energy?

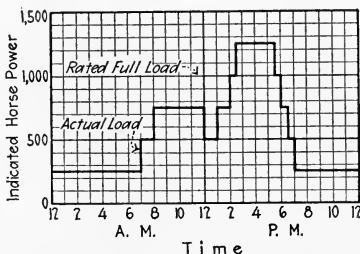

FIG. 500.—Load curve of plant in Prob. 3.

2. If the engine of Prob. 1 cost \$5000, and may be expected to be useful for 28 years, what will be its depreciation charge?
3. A 1000-h.p. non-releasing Corliss-valve engine will cost \$10.00 per h.p. including erection, whereas a uniflow engine of the same capacity will cost \$13.00 per h.p. The Corliss engine will have the following steam rates: at $\frac{1}{4}$ load—29.0 lb. per i.h.p. hr.;

at $\frac{1}{2}$ load—23.9 lb.; at $\frac{3}{4}$ load—23.0 lb.; at full load—23.9 lb. per i.h.p. hr.; at $1\frac{1}{4}$ load—24.9 lb. The uniflow steam rates are: at $\frac{1}{4}$ load—20.3 lb. per i.h.p. hr.; at $\frac{1}{2}$ load—19.6 lb.; at $\frac{3}{4}$ load—19.6 lb.; at full load—20.1 lb.; at $1\frac{1}{4}$ load—21.0 lb. The cost of steam is 50 ct. per 1000 lb. Other operating costs amount to \$1.50 per hour of service. The plant is to operate 300 days per year. Fixed charges may be taken at 15 per cent. of the total first cost of the engine. If the load curve of the plant is as shown in Fig. 500, find the unit energy costs for each of the engines.

4. If in Prob. 3 either another uniflow engine or a Corliss engine would be necessary as a stand-by unit which would probably be operated 15 days out of the year, which would it be wise to install? What would be the unit energy cost of the protection against shut-down?

DIVISION 16

STEAM-ENGINE LUBRICATION

458. The Purpose Of All Lubrication Is To Reduce Friction.

Friction, it is known, causes, enormous financial losses in plants where machinery is employed. These losses, of course cannot be entirely prevented; but, in many cases they can be very greatly reduced by the careful selection and use of lubricants. Before attempting to discuss problems of lubrication it may be well to study the causes and effects of friction in machine or engine bearings.

459. Friction Is A Force Which Resists The Motion of one body or particle over another body or particle with which it is in contact. There are, briefly, three forms of friction: (1) *Rolling Friction Between Solids* (Fig. 501), as in a ball or roller bearing. (2) *Sliding Friction Between Solids* (Fig. 502), as in a plain bearing or between a piston and cylinder. (3) *Fluid Friction Between The Particles Of A Fluid* (Fig. 503), as with water or steam flowing in currents.

460. Rolling Friction Between Solids

may be explained by a consideration of the microscopic structure of the solids, Fig. 501. The surfaces of all solids are known to be covered with very small projections and depressions as shown. When one body rests upon the other, these projections interlock partly and prevent motion. Should an attempt be made, however, to roll the one on the other as shown in Fig. 501, the upper body will have to be raised slightly as it is rolled over a projection and will then fall again. Its movement, as it rolls along, will consist of a series of rises and falls. The center of the body will travel a zig-zag line as shown. Then,

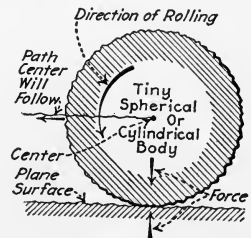

FIG. 501.—Magnified section through small ball or roller in rolling contact with another solid.

too, the rolling body will be slightly "flattened out" where it touches the other body (as occurs with a partially inflated automobile tire). This flattening out is accompanied by a movement between the particles which compose the body. This movement is again *resisted* by internal forces between the particles. Hence, this resistance comprises the *rolling friction* between the bodies.

NOTE.—"WEAR" IS THE RESULT OF THE BREAKING-OFF OF THE PROJECTIONS, Fig. 501. If only the projections were broken off, one might imagine that eventually the outline of the body would be a smooth curve; but, wherever a projection breaks off, a depression is formed in its place leaving the material adjacent to the original projection so that it forms a new projection.

461. Sliding Friction Between Solids (Fig. 502) is similar to rolling friction. The chief difference between the two is in the number of small projections (on the contact surfaces) which are interlocked. In sliding friction, the areas of the contact surfaces are large, whereas in rolling friction they are usually microscopic. With sliding friction (Fig. 502), as with rolling friction, the two bodies must be separated

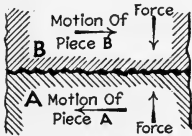

FIG. 502.—Magnified section of two solids in sliding contact without lubrication.

slightly from one another as they move one upon the other. But in sliding friction this separation is effected against the action of the forces which tend to hold the bodies together. Now, since the force which tends to slide the bodies one on the other must separate them against the action of forces, it is obvious that it must do work to effect sliding.

NOTE.—THE FORCE REQUIRED TO SLIDE ONE OF THE BODIES ON THE OTHER is the *force required to overcome friction*. The resistance which one of the bodies opposes to sliding on the other is *sliding friction*.

462. Fluid Friction Between The Particles Of A Fluid may be explained by a study of the velocity of a fluid when flowing through a pipe (Fig. 503). Actual measurements show that this velocity is not the same at all points in the pipe's cross-section but that it is a maximum at the center and a

minimum at the wall. In fact, no accurate measurement can be made exactly at the wall of the pipe and it is very probable that there the velocity would be zero. The velocity at any point on a diameter ab , Fig. 503, is represented graphically by the distance from ab to the curve xy . Now, since the velocity is not the same at any two adjacent points on any diameter as ab , it is evident that adjacent particles of the flowing liquid will be moving upon one another. This movement, however, is resisted by internal forces between the particles of the fluid. The total resistance comprises the *fluid* "friction" in the pipe. In other words, fluid friction

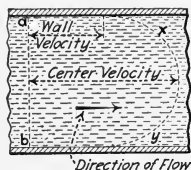

FIG. 503.—Velocity of a fluid in a pipe is not the same at all points in its cross-section.

is the resistance offered by one particle of a fluid to the sliding over it of another particle of the fluid. In general, fluid friction is very much less than sliding or rolling friction.

463. Fluid Friction Replaces Sliding Friction when a fluid is introduced (Fig. 504) between the sliding surfaces of two solids *and kept there*. The fluid adheres to each solid in sufficient quantity to separate the solids and thereby prevent the projections of one from interlocking with those of the other. The fluid then divides—some of it moves with one solid and

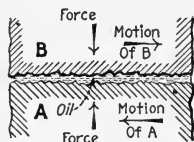

FIG. 504.—Magnified section of two solids in sliding contact with lubrication.

some with the other. The fluid can be thought of in layers which slide upon one another with fluid friction. The amount of fluid friction will depend on the fluid used. The advantage of thus substituting fluid friction for sliding friction between the solids is that the net amount of friction is thereby greatly reduced and "wear" is practically eliminated.

464. The Reason Oils Are Used Between Bearing Surfaces is that they possess the two properties most necessary for a bearing fluid: (1) *A bearing fluid must "wet" the surfaces*; that is, it must *adhere* to the surfaces strongly enough that it will of itself divide into layers, some of which will travel with each of the sliding solids. (2) *It must "stand up"*; that is, its particles must cling together strongly enough that the fluid

will not be squeezed out under the action of the forces between the solids (Fig. 504) which tend to press the solids together. These properties are respectively termed: (1) *Adhesion* and (2) *cohesion* and, together, are called "*body*." They are present in different oils to varying extents. The significance of "*body*" in the selection of lubricants for specific purposes is discussed in Sec. 465.

EXAMPLE.—WATER HAS GREAT ADHERING PROPERTIES but lacks the clinging. Mercury again exceeds in cohesion but lacks adhesion. Hence, neither of these liquids, would make a good lubricant.

465. The "Viscosity" Of A Liquid is a measure of its internal fluid friction or its resistance to flow. A high-viscosity oil is "thick" and flows slowly. A low-viscosity oil is "thin" and flows readily. The viscosity of an oil is usually measured by finding the time required for a certain amount of the oil to flow through a small tube. Besides being a measure of its fluid friction, the viscosity of an oil is, to a certain extent, a measure of its body. See Sec. 472 for a method of measuring viscosity.

NOTE.—THE VISCOSITY OF AN OIL CHANGES WITH ITS TEMPERATURE, decreasing, for any oil, as the temperature of the oil is raised. It is essential, therefore, that one know the viscosity of an oil at the temperature at which it is to be used.

466. Lubricants May Be Grouped Into Three Classes, namely: (1) *Solids*. (2) *Semi-solids*. (3) *Oils*. Each class will be discussed separately, with its uses, in the following sections.

467. Solid Lubricants Are Occasionally Used to smooth out bearing surfaces by filling the small depressions (Fig. 501). Graphite, talc, soapstone, and mica are solids which have lubricating uses. A small percentage of the solid lubricant is usually mixed with a semi-solid lubricant and the mixture is then fed to the bearings. Sometimes solid lubricants are introduced separately to bearings which are also lubricated with oil. Solid lubricants cannot be squeezed from bearings and will, therefore, often keep a bearing cool where no other lubricant will. Experiments have shown that immediately

after a temporary application to an oiled bearing, of solid lubricant in powder form, the friction in the bearing is greatly increased, but is reduced after the particles have had time to attach themselves to the rubbing surfaces and form a smooth coating. The virtue of a solid lubricant lies in the effect which it has of filling the depressions in the bearing surfaces themselves.

468. Semi-Solid Lubricants are those which will not flow at ordinary room temperatures. They are commonly known as "greases." They are desirable for lubricating bearings in places where the air is filled with dust and grit, as in rolling, cement, and other similar mills. Greases are also desirable in applications where bearings are subjected to rather high temperatures. Greases have the property of filling bearing cavities and thereby effectively keeping out foreign matter. They may also be used in bearings into which it would be difficult to introduce oils, as in shaft-governor and similar bearings.

NOTE.—GREASES ARE TO BE USED ONLY WHERE THERE IS SOME GOOD REASON FOR NOT USING OIL because the lubricating properties of greases are poor. Unless a grease melts in a bearing it produces considerable friction. If it does melt it does not lubricate as well as an oil.

469. Oils Are Of Three General Kinds: (1) *Mineral oils* are distilled from the crude petroleums found in many parts of the world. In the distillation processes a great number of grades of oil are obtained. (2) *Fixed* (animal and vegetable) *oils* are obtained by rendering the fatty tissues of animals or by pressing the seeds or fruit of plants. Fixed oils cannot be distilled without decomposition. They are affected more or less by the oxygen in the air which causes them to form solid deposits or *varnishes*. They also decompose, forming acids which will attack bearing surfaces. They are generally not so easily squeezed from a bearing as are mineral oils, because they possess more adhesion. (3) *Compounded oils* are mixtures of mineral oils with small percentages of fixed oils. Compounding a mineral oil improves its adhesion and makes it less likely to be washed from the bearing by water (as in an engine cylinder); but it renders the oil more liable

to gum and cause corrosion and, if the oil is to be used again, makes it harder to separate from entrained water.

NOTE.—METHODS OF HANDLING OIL BARRELS are shown in Figs. 505 and 506.

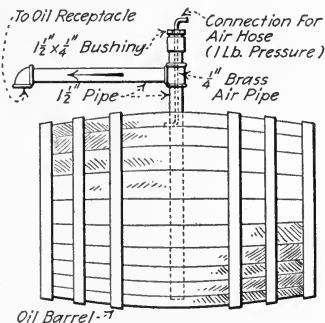

FIG. 505.—Method of emptying a barrel of oil with compressed air. (It is claimed that with this arrangement a barrel of cylinder oil can be emptied in 5 min. and a barrel of engine or other light oil in 3 min. The air pressure should be throttled down and used with considerable caution. Any restriction of the oil discharge or an attempt to force the oil out against a considerable head will result in bursting the barrel. The method can not usually be applied effectively for very heavy oils. It is useful only for oils forced against low heads. (*Southern Engineer.*)

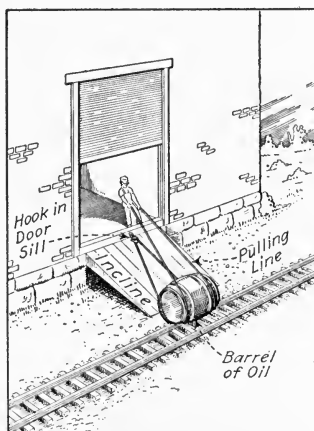

FIG. 506.—Arrangement whereby a barrel of oil can be rolled up an inclined plane by one man.

470. Oils Can Be Tested For Certain Properties which may determine whether or not an oil is suited for a particular use. The most important tests are for the following properties

of an oil: (1) *Specific Gravity*. (2) *Viscosity*. (3) *Flash and Fire Points*. (4) *Chill Point*. These tests will be discussed in following sections. Besides these a useful test is one to determine the extent to which impurities are present in the oil. Impurities can easily be removed by straining the oil through muslin or silk cloth.

471. Its Specific Gravity Indicates The Source Of An Oil And The Method Used In Its Refinement.—The specific gravity of an oil is the ratio of its density (at 60 deg. fahr.) to the density of water (at 60 deg. fahr.). It can conveniently be found (Fig. 507) by floating a “specific gravity” hydrometer, *H*, in a jar of the oil and reading the scale, *S*, of the hydrometer at the level of the oil. The specific gravity of an oil has no direct bearing on its lubricating properties. Oils made from asphaltic-base crudes will generally have a higher specific gravity than oils of a paraffin-base crude. Oils treated by acid will have higher specific gravities than oils treated by filtration.

472. For Measuring Viscosity Of An Oil (Sec. 465), a Saybolt viscosimeter (Fig. 508) is usually employed. The reservoir, *B*, is filled with the oil to

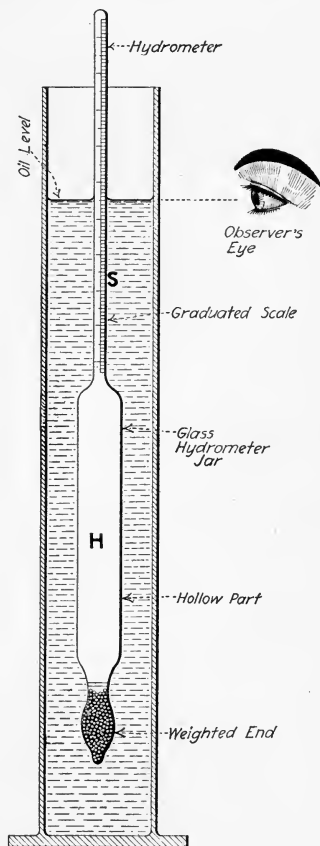

FIG. 507.—Illustrating a hydrometer and its use in finding the specific gravity of an oil.

be tested until the oil begins to overflow into *C*, and the temperature of the bath, *A*, is brought to that at which the measurement is to be made. The stopper, *D*, is then withdrawn and oil flows from *B* through the outlet tube, *F*, into the glass, *G*. With a stop-watch, time is taken until the

glass is filled to the mark. Care must be exercised that no sediment or other obstruction collects in the tube, *F*. The temperatures at which oils are tested for viscosity are usually: (1) *Cylinder oils* at 212 deg. fahr. (2) *Oils for external use* at 104 and 140 deg. fahr.

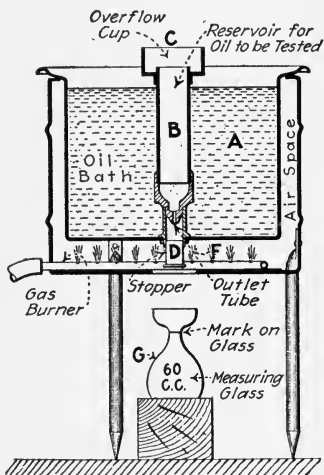

FIG. 508.—Section through a Saybolt viscosimeter.

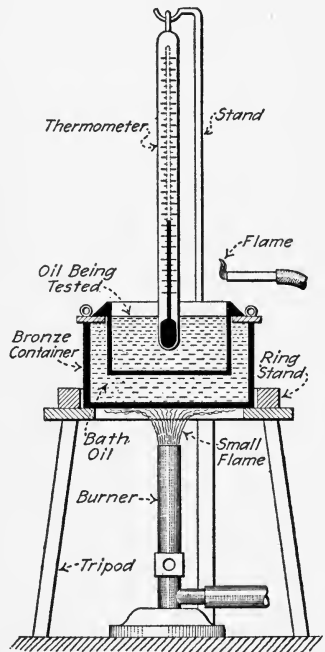

FIG. 509.—Section through Cleveland open-cup tester for flash- and fire-point tests.

473. The Flash Point Of An Oil determines whether it is relatively good or bad for use where at high temperatures it contacts with air. The flash point is the temperature at which the oil will take fire from a flame presented at its surface.

The "fire point" is the temperature at which this fire at the surface will continue after the flame is removed. The flash point is determined by heating the oil (Fig. 509) in a vessel which is either in direct contact with a small flame or in a bath of oil, and applying a flame periodically to its surface until the oil takes fire at the surface. An oil which will flash

at a low temperature is evidently not suited for air-compressor cylinder lubrication.

474. The Chill Point Of An Oil determines whether or not it is fitted for a system where it will be exposed to low temperatures. The chill point is the freezing (or melting) temperature of the oil. It may be conveniently found (Fig. 510) by freezing the oil in a test tube with a suitable thermometer. (Cold-test thermometers are scaled for immersion to a certain mark on the stem.) After the oil is frozen the test tube with the frozen oil in it is withdrawn from the freezing mixture and is held in an inclined position until the oil begins to flow within. The temperature at which the oil begins to flow is the chill point.

NOTE.—THE MELTING POINT OF A GREASE may be found as above by heating the grease in a test tube until it begins to flow.

475. In Selecting An Oil For Any Purpose, there are three requirements which must be satisfied: (1) *The oil must suit the mechanical conditions of the bearing.* (2) *It must suit the lubricating system.* (3) *It must not form deposits as it comes in contact with various substances while performing its functions.*

476. The Mechanical Conditions Of A Bearing are: (1) *The smoothness of its surfaces.* (2) *The rubbing speed.* (3) *The pressure on the journal or bearing.* (4) *The temperature of the bearing.* They affect the selection of an oil as follows: (1) *Rough surfaces* require oils of greater viscosity and body than do smooth surfaces because rough surfaces must be kept farther separated by the oil. (2) *Bearings with high rubbing speeds* do not require oils with as much body as do those with low rubbing speeds because the higher speeds work the oil into the bearings faster and do not give the "squeezing" influence of the bearings as much time to get rid of the oil as do low rubbing speeds. (3) *Bearings subjected to high pressures* must have oils of comparatively high viscosity and body to keep the oil from being squeezed out, whereas in bearings which operate

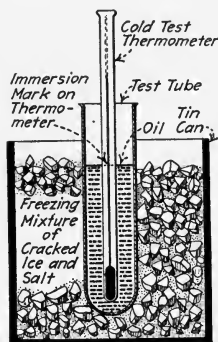

FIG. 510.—Simple apparatus for finding chill point of an oil.

under light pressures, a light-bodied oil may be used and benefit derived by its lesser fluid friction. (4) *Oils for bearings that are situated in regions of high temperature* or for bearings to which heat may readily flow must, since oils lose their viscosity and body as their temperatures are raised, be supplied with relatively high-viscosity oils.

477. How The Lubricating System Affects The Choice Of An Oil can best be understood by one or two examples. Where, for instance, bearings are fed by hand, an oil must be used which will hold a film until the bearing is again oiled. But where a continuous stream of oil is fed to the bearings, the oil need not be of the same quality. Likewise, in a system where an oil is to be cleaned and used over again, the oil must be one which will separate readily from impurities which it may collect.

478. Certain Oils May Form Deposits when they come into contact with the air, gases, or other substances. These deposit-forming oils would, of course, be unsuited for use in places where such deposits would be likely to occur, even though they may satisfy the mechanical conditions of the bearings and the lubrication system. In the steam engine deposits are apt to be formed by (1) *water*, (2) *solid impurities*, (3) *the air* or by (4) *adding new oil* to an old supply. Whether or not an oil will form deposits can best be ascertained only after a thorough trial of the oil in the system where it is to be used.

479. The Selection Of Oils For Steam-Engine Lubrication can be greatly facilitated by the use of the following tables and Fig. 511 which are from THE PRACTICE OF LUBRICATION by T. C. Thomsen. The descriptive terms applied to the oils have reference to methods used in their distillation and refinement and cannot be explained here; see PRACTICE OF LUBRICATION. The oiling systems referred to will be described in subsequent sections.

480. Table Of Properties Of Circulation Oils.—All circulation oils must separate rapidly from water. Circulation oil No. 1 is a neutral filtered oil. Circulation oil Nos. 2 and 3 are mixtures of a neutral filtered oil with filtered cylinder stock.

Circulation oil No.	Specific gravity	Flash point (open cup), deg. fahr.	Saybolt viscosity in seconds		Chill point, deg. fahr.
			At 104 deg. fahr.	At 140 deg. fahr.	
1	0.870	395	135	70	20-25
2	0.900	410	265	120	35-40
3	0.900	425	500	200	35-40

481. Table Of Properties Of Cylinder Oils.

Cylinder oil	Saybolt viscosity at 212°F., seconds	Specific gravity		Open flash point, deg. fahr.		Cold test, deg. fahr.	
		Filtered	Dark	Filtered	Dark	Filtered	Dark
No. 1 filtered.....	85-105	0.885	500	...	40-50
No. 2 filtered, No. 2 dark	115-135	0.887	0.900	525	520	50-60	40-50
No. 3 filtered, No. 3 dark	145-165	0.890	0.905	550	530	50-60	40-50
No. 4 dark	180-200	0.910	...	580	50-60

NOTE.—CYLINDER OILS MAY BE COMPOUNDED WITH ACIDLESS TALLOW OIL, or may be used without compounding. The following tables show their uses in each state.

482. Table Of Cylinder Oil Grades.—The uses of each grade are given in Fig. 511.

Grade of oil	Designation
No. 1 filtered cylinder oil, heavily compounded (10 per cent.)	1 F.H.C.
No. 1 filtered cylinder oil, lightly compounded (4 per cent.)	1 F.L.C.
No. 2 filtered cylinder oil, medium compounded (6 per cent.)	2 F.M.C.
No. 3 filtered cylinder oil, medium compounded (6 per cent.)	3 F.M.C.
No. 2 dark cylinder oil, medium compounded (6 per cent.)	2 D.M.C.
No. 3 dark cylinder oil, medium compounded (6 per cent.)	3 D.M.C.
No. 3 dark cylinder oil, heavily compounded (10 per cent.)	3 D.H.C.
No. 4 dark cylinder oil, medium compounded (6 per cent.)	4 D.M.C.
No. 2 filtered cylinder oil, straight mineral.....	2 F.S.M.
No. 2 dark cylinder oil, straight mineral.....	2 D.S.M.
No. 3 filtered cylinder oil, straight mineral.....	3 F.S.M.
No. 3 dark cylinder oil, straight mineral.....	3 D.S.M.

Grade of Oil	Size Of Cylinders		Horizontal Or Vertical Construction		Tailrod		Steam Pressure Lb. Per Sq. in.			Steam Temperature Degrees Fahrenheit			Condition Of Steam		Condition Of Exhaust			
	Below 16"	Over 16"	Horiz-ontal	Ver-tical	With	With-Out	Below 100	100 To 140	Over 140	Below 400	400 To 525	Above 525	Wet	Dry	Non-Condensing Or Wet Condensing	Surface Condensing Cool Means For Frictioning Oil	Oil Elimination Particu-larly Important	
1FHC																		
1FHC																		
1FHC																		
1FHC																		
	Also Recommended For Large Low Pressure Cylinders With Wet Steam																	
1FLC																		
1FLC																		
1FLC																		
2FMC																		
2FMC																		
2FMC																		
3FMC																		
3FMC																		
3FMC																		
2DMC																		
3DMC																		
3DHC																		
4DMC																		
2FSM																		
2DSM																		
3FSM																		
3DSM																		

FIG. 511.—Lubrication chart for steam cylinders and valves. (From PRACTICE OF LUBRICATION by T. C. Thomsen.)

NOTE 1.—For light-load conditions choose an oil slightly lower in viscosity or more-heavily compounded than the one indicated by the chart.

NOTE 2.—With impure steam (priming boilers) a filtered oil should preferably be used, and with saturated steam preferably a compounded oil.

NOTE 3.—When the chart recommends more than one grade, the one lowest in viscosity should preferably be chosen. When a dark oil as well as a filtered oil is indicated, as will often be the case, the former, unless there are special conditions (NOTE 2) may be preferred as it is (or ought to be) lower in price.

NOTE 4.—A straight mineral oil can always be used in place of the compounded oil recommended by the chart but it means an increased oil consumption as compared with a medium compounded oil of 50 to 100 per cent. The use of a straight mineral oil in place of a lightly-compounded oil or the latter in place of a heavily-compounded oil means an increase in oil consumption of 30 to 50 per cent.

NOTE 5.—From 10 to 15 per cent. of compounding may be required in case of: (a) *Very wet steam in large engines, low-pressure cylinders in particular.* (b) *Heavily-loaded Corliss valves or unbalanced slide valves.* (c) *Very-dirty steam, particularly saturated steam.*

NOTE 6.—No. 2 FSM and 3 FSM will separate easier from the exhaust steam than No. 2 DSM and 3 DSM and will give a cleaner and better lubrication, particularly under conditions of superheated steam or impure steam.

NOTE.—TO USE THE CHART OF FIG. 511 cut a strip of paper long enough to extend across the chart. Then for each of the seven factors which are specified along the top of the chart, make a mark on the paper in line with the condition of the engine to lubricate. There should be seven marks on the paper. Then slide down the paper until a line is reached when no shaded spaces appear in the same columns as the marks on the paper. Then read off at the left the oil to be used.

483. Table Of Uses Of Bearing Oils In Steam Engines oiled by the gravity-circulation or drop-feed system. (See Secs. 488 and 493.)

Bearing oil	Saybolt viscosity at 104°F., seconds	Circulation systems, engine h.p.	Drop-feed systems, engine h.p.
No. 2.....	120	Below 250	Below 100
No. 3.....	175	250 to 400	100 to 250
No. 4.....	250	Above 400	250 to 500
Nos. 5, 6.....	450-700	¹ Special cases only	Above 500

¹ By "Special Cases" is meant where the bearing pressures are extremely high, where they have large clearances, or where they are so situated that their temperatures are likely to be high by reason of heat flow from some nearby hot object.

NOTE.—In circulation systems or where the oil is used over and over, a straight mineral oil must be used. Otherwise a compounded oil may be used if desirable.

484. Table Of Oils For Use In Force-Feed Circulation Systems.—(See Sec. 494 and Table 480.)

Engine size	Circulation oil number
For engines below 150 h.p.....	No. 1
For engines 150 to 400 h.p.....	No. 2
For engines over 400 h.p.....	No. 3

NOTE.—Some engines have unusually heavy connections between the cylinder and the crank case permitting a large amount of heat to flow down to the crank case. For such engines and where the bearings have unusually large clearances, engines below 250 h.p. require circulation oil No. 2 and those above 250 h.p. require No. 3.

485. Table Of Oils For High-Speed, Splash-Oiled Engines.
(See Table 480 and Sec. 492.)

Engine description	Grade of oil	Percentage of oil in bath
Small horizontal engines (stationary).....	Circulation No. 1 or No. 2	100
Small horizontal engines in vehicles.....	Circulation oil No. 3 or an oil of even higher viscosity	100
Vertical engines below 50 h.p..	Circulation oil No. 2 or cylinder oil No. 2 F.L.C.	15 4 to 6
Vertical engines 50 to 300 h.p..	Cylinder oil No. 2 F.L.C.	4 to 6
Vertical engines above 300 h.p.	Cylinder oil No. 3 F.M.C. or cylinder oil No. 3 D.M.C	3 to 4 3 to 4

486. Lubrication Systems For Steam Engines may be divided into two classes: (1) *Systems for lubricating external bearings.* External bearings are those which are not enclosed within the parts of the engine which hold steam. (2) *Systems for lubricating internal bearings.* The internal bearings of a steam engine are the piston, cylinder, valves, and stuffing boxes. Every engine will employ one system of each of the above classes. The principal systems of each class will be described and discussed in the following sections.

NOTE.—SYSTEMS FOR EXTERNAL-BEARING LUBRICATION MAY BE FURTHER CLASSIFIED into: (1) *Automatic systems*, in which the oil is repeatedly used in the bearings and needs replenishment only to make up for losses by evaporation and leakage. (2) *Non-automatic systems*, in which the oil is used by a bearing but once and is then no longer available for lubrication unless it is collected by an attendant and replaced into the system.

487. Lubrication Of External Bearings By Hand is the most primitive, wasteful, and unreliable of systems. This system should, preferably, never be used on all parts of steam engines. *Hand lubrication* is that method in which the oil is applied directly from an oil can to the “lubricated?” part or into an oil hole which is supposed to conduct the oil to the part. To employ human labor for the performance of a duty which can so easily be performed automatically, or nearly so, is, in most

cases, wasteful. Next, the tendency on the part of the human oiler is to flood each bearing with oil when attending to it and then to neglect it as long as possible. Such attention results in a great waste of oil and no great reduction in bearing friction, since the bearing is nearly always in only a semi-lubricated condition—it is lubricated merely by what oil has remained in the bearing.

NOTE.—HAND OILING IS SOMETIMES SATISFACTORY FOR STEAM ENGINE BEARINGS which have very limited motion and small bearing loads. For example, it is frequently used for valve and governor mechanisms, for slow-speed rocker arms, and the like. For high-speed large-bearing-load lubrication it is extravagant and unsatisfactory.

NOTE.—THE OIL FOR A HAND-OILING SYSTEM must be one which will not readily flow out of the bearing. It must “cling” to the bearing surfaces and withstand their “squeezing” action. Hence, it is essential that it have a high viscosity and great adhesion. High viscosity, again, will mean great fluid friction which further lessens the value of the lubrication. High-viscosity compounded oils (Sec. 483) are best suited to hand-feed systems.

488. “Drop-Feed” Lubrication Of External Bearings includes all oiling devices which provide a regular feeding of oil, drop by drop, to the bearings. Drop-feed oiling provides more uniform lubrication than hand oiling but has some disadvantages. Generally, with it no oil-purifying apparatus is employed and the oil is generally used once and then wasted. Such use of oil usually results in feeding just a bare minimum of oil to the bearings and, to keep down the oil cost, a heavy oil is purchased and therefore friction is not reduced to a minimum. Also, drop-feed oilers require constant attention to insure that they do not run empty. They also feed more oil when filled to the top than when nearly drained. See Table 483 for recommended oils for drop-feed lubrication.

NOTE.—DROP-FEED OILERS (Figs. 512 and 513) ARE MOUNTED directly over stationary (and, in some cases, moving) bearings. Methods of delivering oil from oilers to moving engine bearings will be discussed in subsequent sections.

NOTE.—SHOULD THE SIGHT-FEED BE BROKEN FROM A DROP-FEED OILER IT MAY BE REPAIRED with pipe fittings as shown in Fig. 514. After drilling a peep hole, *H*, through a coupling, *C*, two bushings, *B*,

are screwed firmly into it and the glass, *G*, is set with cement or putty. The lower end of the original oiler may readily be fitted to the new sight-feed as shown in Fig. 515.

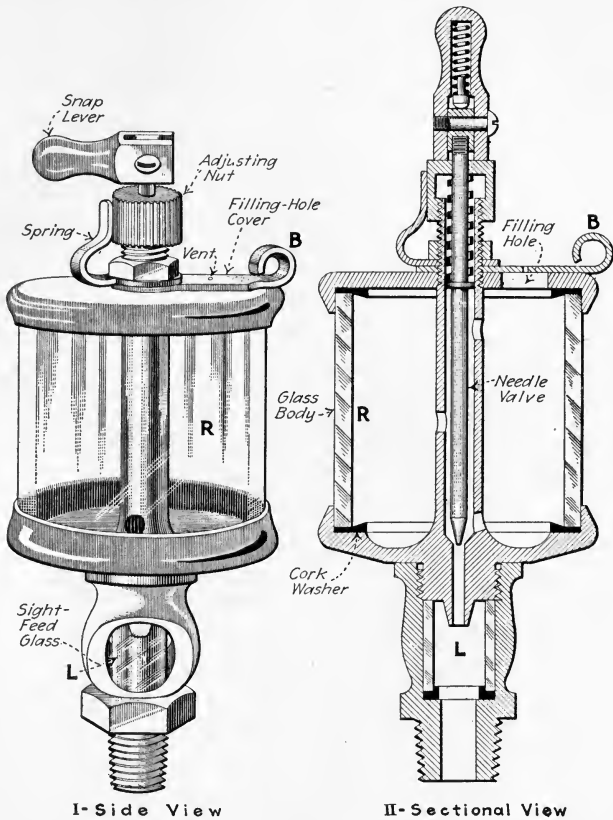

FIG. 512.—Typical drop-feed oil cup with sight feed. (Lunkenheimer Co.)

489. The Suitable Applications For Drop-Feed Lubrication On Steam Engines are those where the engine is not sufficiently large to justify the cost of a complete splash or circulation oiling system or where the engine is used infrequently. It is seldom that this system is used to the exclusion of others on engines of capacities greater than, say, 25 h.p. Often on larger engines, even the largest, this system is employed for the slow-speed light-load bearings such as the wrist plates, rocker arms, governor spindles and the like.

490. The Bottle Oiler (Fig. 516), although not widely used on steam engines, is an ingenious device and gives good results when properly adjusted. The plunger, *C*, fits loosely in the brass tube, *A*, so that, as *C* is given a little motion up and down by the rotation of the shaft, oil will work down onto the shaft. Oilers of this type are very useful on shaft bearings—particu-

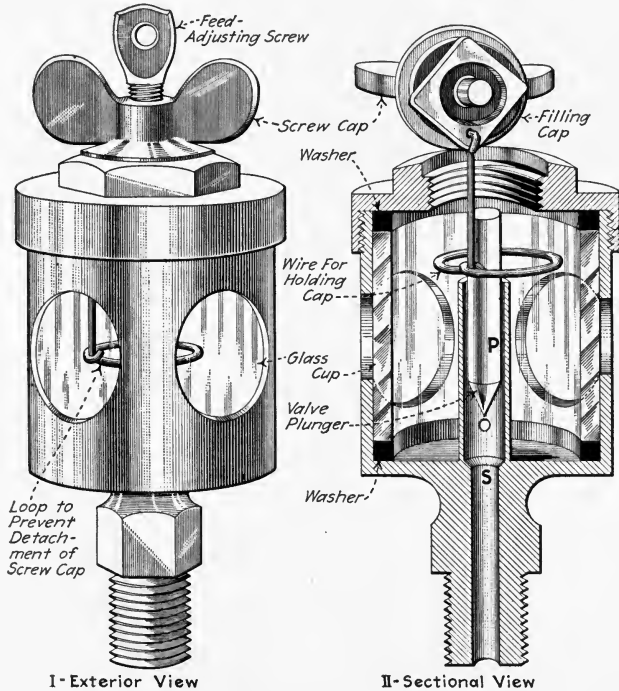

FIG. 513.—Crank-pin oiler for attachment to connecting rod. (The valve plunger, *P*, rises and falls as the crank pin rotates thus controlling the oil feed. With the engine stopped, *P* rests against the seat *S* shutting off the oil flow. American Injector Co.)

larly line shafts—which run intermittently, because, due to its viscosity, they feed no oil when the shafts are still. They are made with glass bodies so that the oil content of the reservoir is visible at all times. Adjustment of oil-feed can only be attained by changing the plunger for one of a different diameter. The smaller the plunger diameter, as compared to the bore

of the tube within which it fits, the greater will be the rate of oil-feed.

491. Ring-Oiled Bearings (Fig. 517), although seldom found on steam engines, are very effective and reliable. The bearing cap, *C*, is cut away, for a small portion of its length, to allow

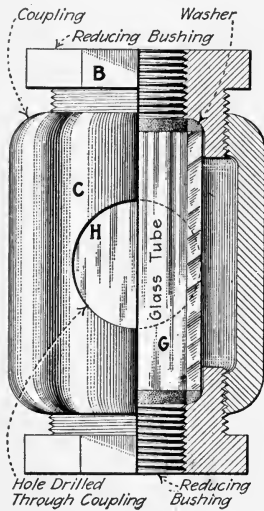

FIG. 514.—Improved sight feed for drop-feed oiler. (F. W. Bentley, Jr., in *Power*, June 11, 1918.)

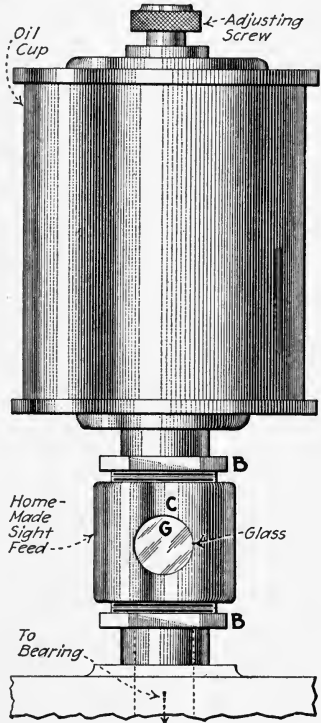

FIG. 515.—Homemade sight feed applied to drop-feed oiler.

the oiling ring, *R*, to ride upon the shaft, *S*, as shown. As *R* is always dipping into the oil in the reservoir, *A*, and as rotation of *S* will cause *R* to “ride” it and thereby also revolve, *R* will continually carry oil upward onto *S*. A liberal quantity of oil is thus fed to the bearing whenever the shaft rotates. Ring-oiled bearings require attention only to see that enough oil is within the reservoir (some oil is lost by leakage and evapo-

ration). A periodic renewal of the oil in the bearing will prevent the accumulation of grit and damage resulting from it.

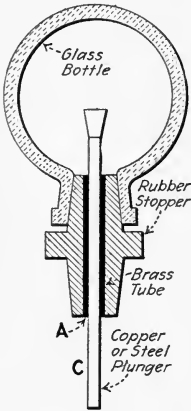

FIG. 516.—Glass bottle-oiler.

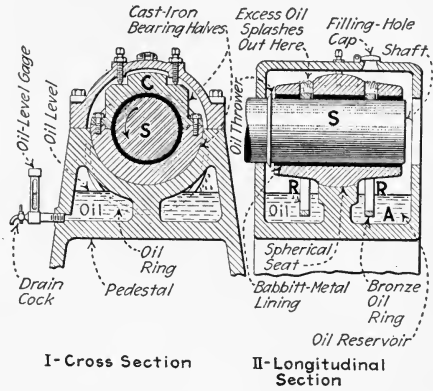

FIG. 517.—Typical ring-oiled bearing. (The spherical seat makes the bearing self-aligning.)

492. The Splash System Of External-Bearing Lubrication, Fig. 518, is widely used on modern medium- and high-speed engines. The crank disc, *B*, dips into the oil in the crank case

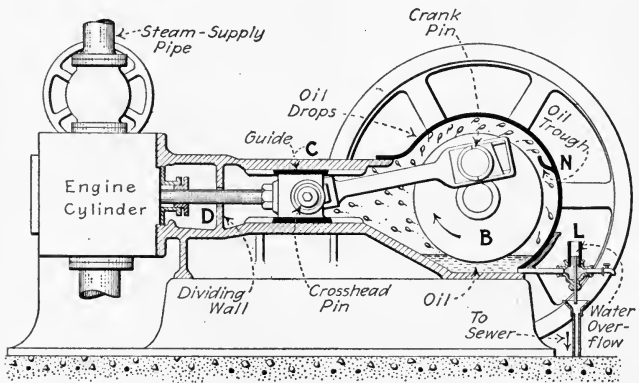

FIG. 518.—A typical splash-oiled engine.

to a depth of about 2 in. and throws the oil, which it picks up, onto the crosshead guides, *C*, and the crosshead. Some oil is collected in the trough, *N*, from which it is led by pipes

(Fig. 519) to the main bearings and to the eccentric. Small quantities of water will work their way into the crank case (steam which leaks through the packing gland and then condenses) and must be removed. This may be done automatically with an overflow pipe as shown at *L* in Fig. 518. Frequently, an auxiliary stuffing box is placed on the dividing

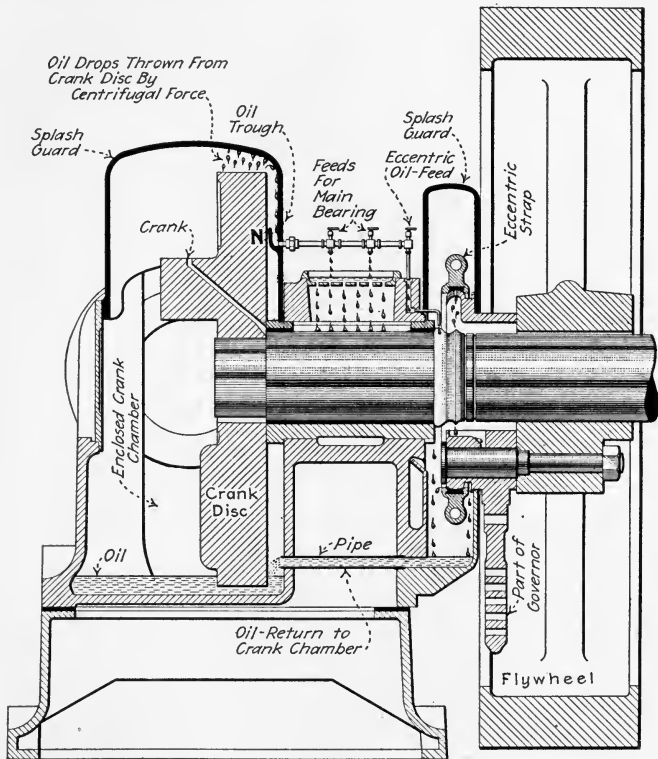

FIG. 519.—Section through splash-oiled engine at shaft, showing oil distribution to bearings. (Chandler & Taylor Co.)

wall, *D*, to keep water out of the crank case. In vertical single-acting engines [with large crank chambers the oil reservoir is, to minimize the quantity of oil required, frequently filled to within $\frac{3}{4}$ in. of the under side of the crank shaft with water upon which a layer of oil $\frac{1}{8}$ to $\frac{1}{4}$ in. thick is then poured. The dipping of the connecting rod into this mixture

forms an emulsion which is then splashed to the several bearing points. Oils for splash systems are given in Table 485.

493. The Gravity-Circulation System Of External-Bearing Lubrication (Figs. 520 and 521) is one in which oil is supplied to the external bearings from an overhead tank, *A*, and, on leaving the bearings, the oil is collected and again returned to the overhead tank by a pump, *B*. The rate of oil-feed to each bearing is regulated by a needle valve in a sight-feed

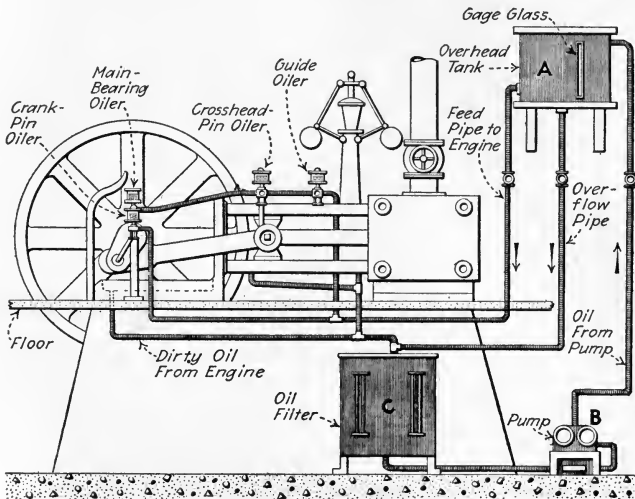

FIG. 520.—A typical gravity-circulation lubrication system with filter at the lowest point.

oiler (Fig. 522). The chief advantage of the gravity-circulation system is that it provides a continuous and generous supply of oil to every bearing. Another advantage is that it lends itself so readily to the use of an oil filter, *C* (Fig. 520), which insures the supplying of clean oil to the bearings at all times and permits the use of the same oil for an indefinite length of time. New oil need be added only to make up for losses by leakage and evaporation. Any reasonable arrangement of filter and overhead tank may be adopted to satisfy building, space and other considerations.

EXAMPLES.—The filter, *C*, may be so located that the dirty oil from the bearings flows to it by gravity, as in Fig. 520. Or, the filter may be

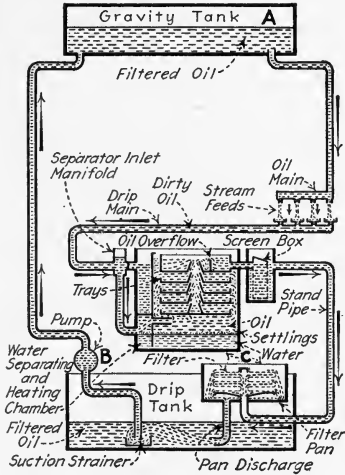

FIG. 521.—Filtering and-circulation oil system. (S. F. Bowser & Co., Inc.)

situated above *A* and discharge by gravity into *A*, in which arrangement the dirty oil is pumped from a collecting basin up to *A*. A third plan is to locate the filter at any level and pump the oil to and from it by separate

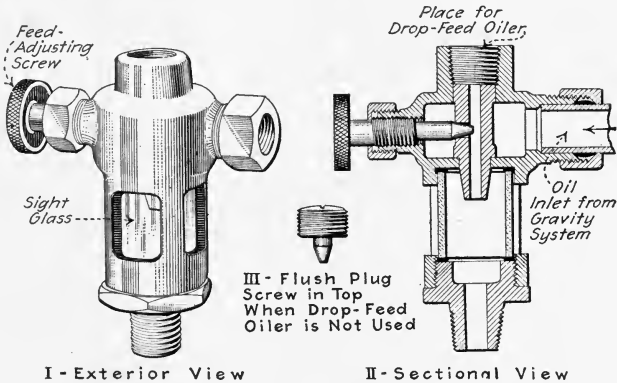

FIG. 522.—Four-window sight-feed oiler for gravity oiling system. (Richardson-Phenix Co.)

pumps. Fig. 521 shows diagrammatically the oil-flow in the system of Fig. 520. Oil filters will be discussed in following sections. Oils for gravity-circulation lubrication systems are specified in Table 483,

NOTE.—AN INEXPENSIVE GRAVITY-CIRCULATION LUBRICATING SYSTEM WITH HAND PUMPS is shown in Fig. 523. Tanks *A*, *B*, *C*, and *E* can have any shape. *F* and *G* are hand force-pumps. *D* is the oil filter. Tanks *B* and *C* are simply to hold supply oil for *A* and *D* and thereby make continuous pumping unnecessary.

494. The Force-Feed Circulation System Of External-Bearing Lubrication, Fig. 524, is one in which oil is supplied to the external bearings by a pump, *A*, under a pressure of, say, 5 to 15 lb. per sq. in. The oil is taken from the reservoir, *R*, in the crank case by *A* and delivered through pipes, *B*, to the main bearings. Since the crank shaft is hollow, the oil is led, as shown from the main bearings to the crank pins and eccentric. It is then conducted through pipes, *C*, to the cross-head pins. Oil which leaves the crosshead splashes onto the guides and thence falls back into the reservoir. An adjustable relief valve, not shown, permits by-passing some of the oil into the reservoir as it is discharged by the pump. The oil-feed to the bearings can be increased by adjusting the relief valve to maintain a higher pressure at the pump discharge. As the bearings become worn, a higher pressure is necessary to keep them filled. Also, a light oil will require a higher pressure than a heavy oil. Water, which will find its way into the crank case from the cylinder, must be drained off at frequent intervals. A scraper

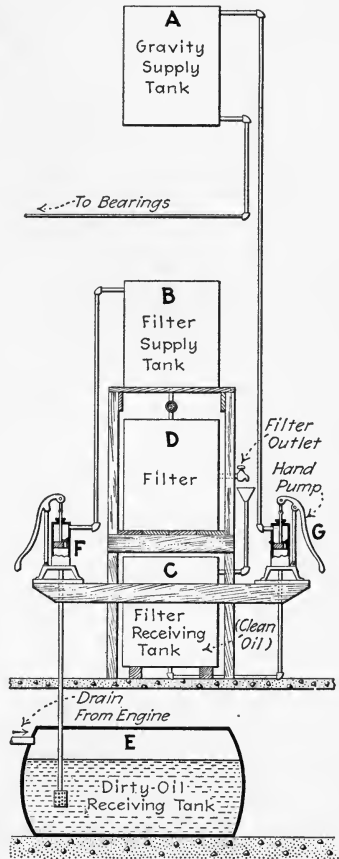

FIG. 523.—A simply-constructed gravity-circulation system. (T. G. Thurston, in *The National Engineer*, Feb., 1916.)

Water, which will find its way into the crank case from the cylinder, must be drained off at frequent intervals. A scraper

gland, *D*, on each piston and valve rod, may be effectively used to keep some of the water out of the crank chamber. See Table 484 for recommended oils for force-feed circulation systems.

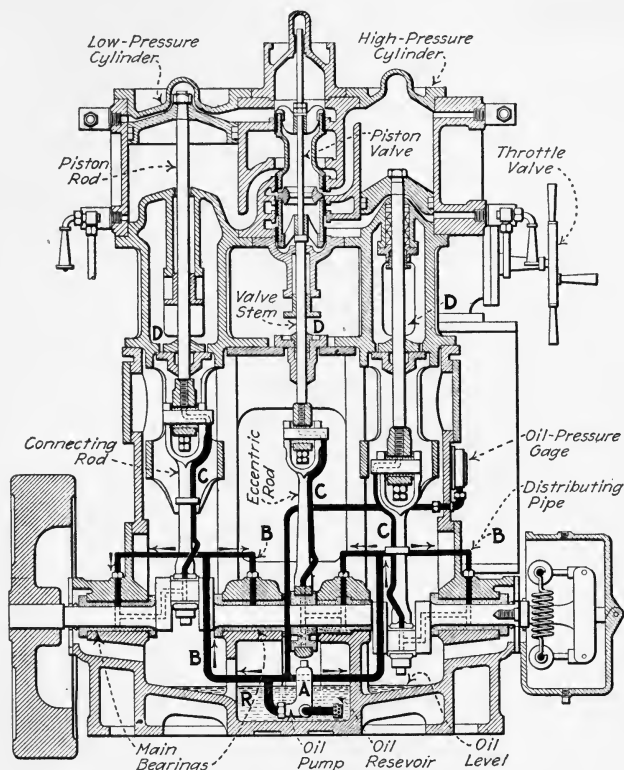

FIG. 524.—Compound marine engine with force-feed lubrication.

495. The Relative Merits Of Automatic Lubrication Systems For External Bearings may be briefly stated as follows: (1) *Splash-oiling systems* are inexpensive in first cost and operate very satisfactorily on engines of speeds of 200 r.p.m. or more. The oil must be periodically renewed but, if filtered, can be used over and over. (2) *Gravity circulation systems* afford a copious supply of oil to each bearing, are simple and easy to operate, and can be fitted to any engine. The flow of oil to each bearing is known and is readily adjustable.

(3) *Force-feed circulation systems* are very positive—that is, the oil supplied to a bearing is more apt, than in the first two systems discussed, to actually enter between the bearing surfaces. On the other hand, the oil-feed to each bearing is unknown, and if, for any reason, a pipe or passage should become clogged this may only be evidenced after serious damage to the bearing. In view of the above, the gravity circulation system is becoming very widely used for modern slow-speed engines, whereas the splash system is in general use on higher-speed engines.

496. Methods Of Supplying Oil To Moving Bearings Of Medium- And Slow-Speed Engines are numerous and are

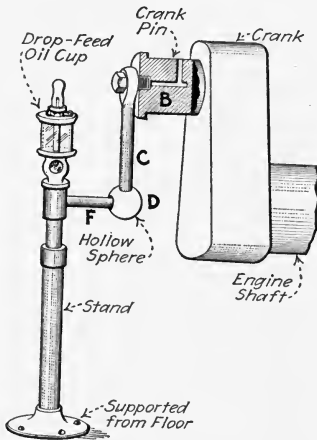

FIG. 525.—“Banjo” crank-pin oiler for side-crank engine.

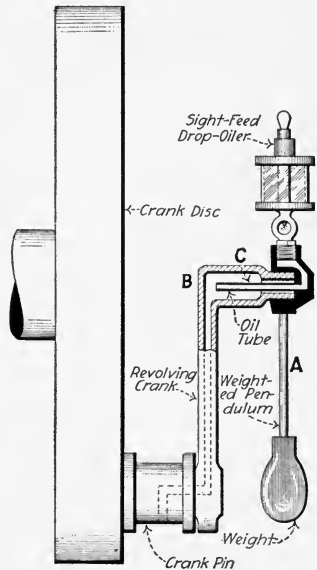

FIG. 526.—Nugent crank-pin oiler.

usually such that an engine need not be shut down to adjust the oil feed or, where necessary, to fill the oilers. In the illustrations which accompany this section, hand-supplied drop-feed oilers are shown. But oil may be conducted to these oil cups by a gravity oiling system if such is available. In the crank-pin oiler (Fig. 525), which is widely used, oil is fed

from the cup to tube *F*, which delivers it to the hollow ball *D*. Tube *C* is fastened securely to *D* and to the crank pin,

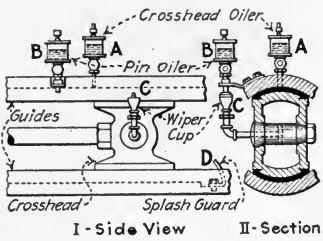

FIG. 527.—Method of using wiper cup in oiling crosshead pin.

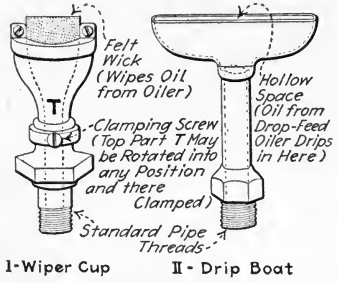

FIG. 528.—Oil collecting devices. (Sherwood Mfg. Co.)

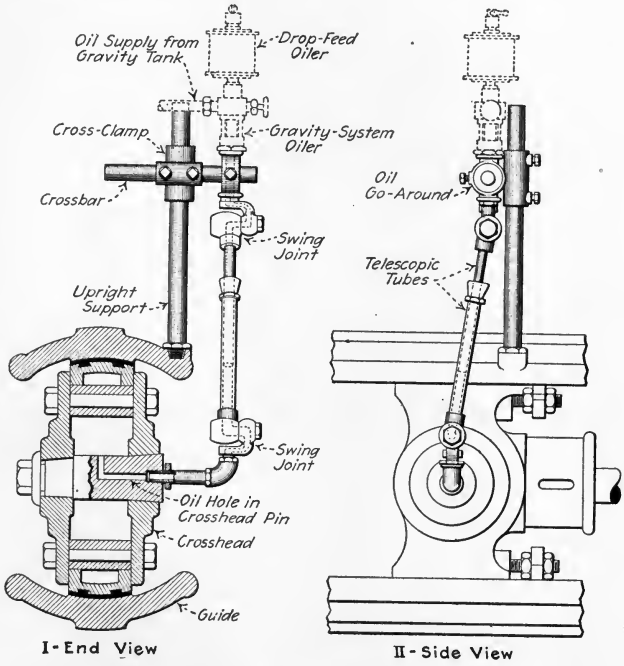

FIG. 529.—Crosshead-pin telescopic oiler. (Richardson-Phenix Co.)

B, and rotates with *B*. Oil, dripping from *F* to *D*, is carried through *C* by centrifugal force and enters *B* where it lubricates the bearing. A similar device is one (Fig. 526) in which the

oil cup, instead of being mounted on a rigid support, is held upright by a weighted pendulum to which it is attached; this is not suited to the gravity system. The revolving crank, *B*, receives oil from tube *C* and delivers it to the crank pin. The usual method of oiling the crosshead guides (Fig. 527) is to drop oil from the cup, *A*, onto the upper shoe. Drips from *A* and from the pin lubricate the lower shoe, being retained by splash guards, *D*, at each end of the guide.

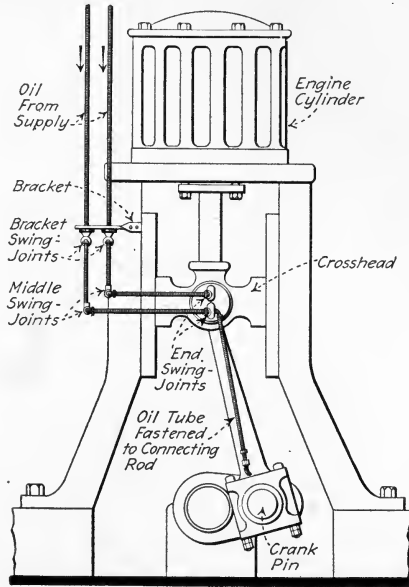

FIG. 530.—Vertical engine equipped with swing joints for supplying oil to crank and crosshead pins.

NOTE.—ECCENTRICS AND CROSSHEAD PINS ARE FED BY WIPER CUPS OR TELESCOPIC TUBES (Figs. 527, 528 and 529). The wiper cup, *C* (Fig. 527), supplies the crosshead pin with oil from *B*. Fig. 528 shows a wiper cup and a drip boat which is used as a wiper cup for feeding oil to eccentrics. Telescopic tubes (Fig. 529) are more effective for crosshead pin and eccentric oiling but are not applicable to crosshead pins of vertical engines. On the other hand, the swing-joint arrangement of Fig. 530 is especially suited to vertical engines. Swing-joint and telescopic oilers cannot be used effectively on high-speed engines because of the liability of their becoming disarranged or broken when operating at high speeds.

497. The Operation Of A Good Oil Purifier Or Filter (Figs. 531, 532 and 533) usually comprises three separate processes: (1) *Screening* is intended to remove the coarser impurities and relieve the following processes of as much burden as is feasible. (2) *Precipitation* consists of allowing the finer impurities of higher specific gravity than the oil—such as fine metallic wearings and water—to settle out from the oil. Precipitation is often accelerated by heating the oil, thus lowering its viscosity and allowing the impurities to pass more freely through it. Separated water should be removed by an automatic overflow. (3) *Filtration* is intended to remove the very finest floating impurities in the oil—those which have not been removed in either the screen or the precipitation chamber.

NOTE.—PASSING THE OIL THROUGH WATER DOES NOT REMOVE IMPURITIES although some engineers try to filter oil in this way. The oil rises through the water in drops from which the impurities cannot be removed no matter how hot the water may be.

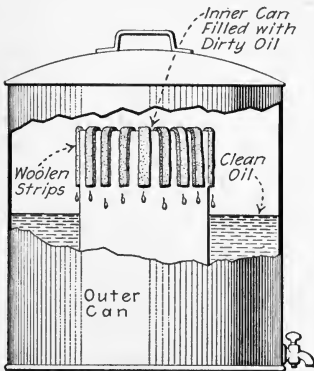

FIG. 531.—A simply-constructed oil filter. (J. C. Kahl, in *Southern Engineer*, Sept., 1910.)

498. The Filtering Materials Used In Oil Filters are various. Most small filters employ, as a filtering medium, cotton waste, sawdust, wool, or other loose material, but in large filters cloth is universally used. Even for small filters, cloth in the form of a simple bag is preferable to loose material. Loose material, unless well packed, will allow channels through which the oil will pass without being filtered. If tightly

packed, such material reduces the filter's capacity to possibly 1 or 2 gal. per day. Filter cloth should preferably be arranged so that the impurities will fall away from the cloth as they collect. With horizontal filter surfaces, the oil should flow upward through the cloth which should have a pan under it to prevent the impurities falling on the cloth beneath. Vertical filter surfaces are preferable to those

horizontal surfaces through which the oil flows downward through the cloth, as the latter are apt to become clogged with impurities. It is also desirable to have the two sides of the

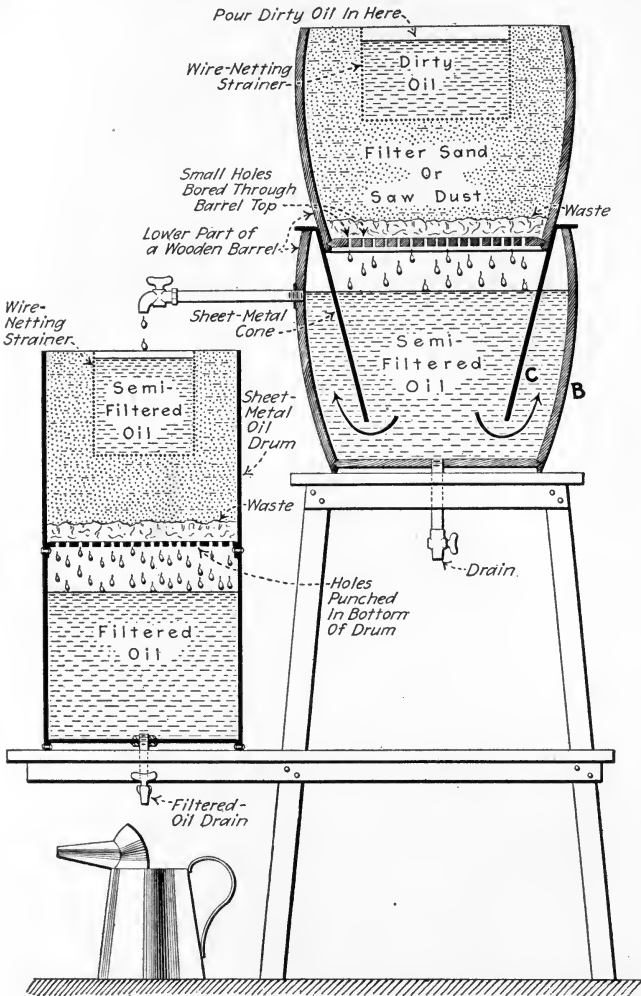

FIG. 532.—A simply-constructed improvised oil filter. (E. Grossenbacher, in *Power*, Mar. 9, 1920.)

filter surface exposed to the same difference in oil pressure at all points. If the oil at the bottom of a filtering surface is

forced through at a greater pressure than at the top, the cloth at the top will pass less oil than that at the bottom, and, furthermore, impurities may be forced through at the bottom by the greater pressure. In some small filters the oil is filtered by syphoning it through felt strips.

NOTE.—IMPROVISED OIL FILTERS MAY BE CONSTRUCTED READILY. Fig. 531 shows such a filter which employs felt strips as the filtering material. It gives very satisfactory results as only clean dry oil will

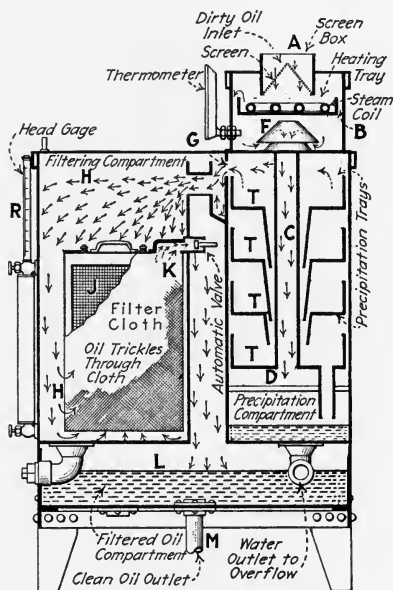

FIG. 533.—Oil filter. (Richardson-Phenix Co.)

syphon over the top of the inner can. Fig. 532 shows a homemade filter employing a loose filter-material and made of barrel and can parts. In using such a filter care must be taken that the material is closely packed especially at the outer edges and that water does not collect in barrel B to a level higher than the bottom of cone C, as this would permit water to enter the second compartment.

499. Oil Purifiers, Usually Called Filters, Are Manufactured in capacities up to 3800 gal. per min. In the Peterson oil filter (Figs. 533 and 534) oil is poured in and screened at A, and after passing over the heating coils, B, flows down the tube, C, striking deflector, D. From the bottom, the oil

flows slowly upward over the several trays, *T*, gradually losing its water and heavy impurities, and finally passes through *G* into the filter compartment, shown in Fig. 533. The separated water flows to the bottom of the precipitation chamber through the funnels around *C* and through the tube, *E*. It is automatically discharged through the overflow pipe, *P*, which is adjustable in height for different oils. In the filtration compartment, *H* (Fig. 533), the oil flows through the filter

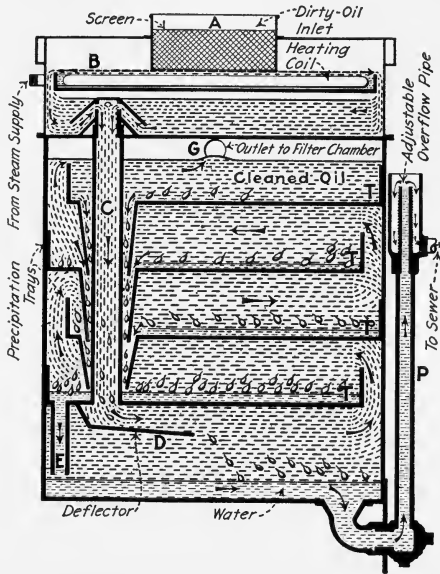

FIG. 534.—Section through precipitation compartment of the oil filter shown in Fig. 533.

cloth, which is supported on frames, *J*, from the outside to the inside. Impurities collect on the filter surfaces and fall to the bottom of *H*. The clean oil flows from the inside of frames, *J*, through valves, *K*, into the clean oil compartment, *L*.

NOTE.—As the filter frames, *J*, are always full of oil, there exists the same difference of pressure between outside and inside of the cloth at all points on the cloth. This pressure is shown by the height of oil in the head gage, *R*. The clean oil is taken out through pipe *M*.

500. In A Bowser Oil Filtering Outfit (Fig. 535), dirty oil is introduced and screened at *A* and collects in the refining and purifying chamber, *P*, where it is heated by the steam

coil and then passes up over the trays, *B*. The oil then overflows through the regulating valve, *E*, to the filter bag, *C* through which it passes to *D*, the clean oil storage tank. Another Bowser outfit is that shown diagrammatically in Fig. 521. The filter cloths in this outfit are placed in the horizontal position in the filter pan and allow the oil to pass upward through them. Pans (not shown), between the layers of filter cloth, catch the impurities as they fall from the cloth surface.

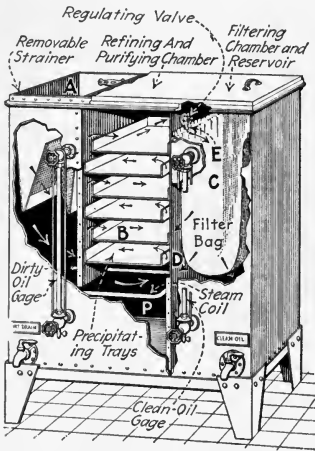

FIG. 535.—Oil filtering outfit. (S. F. Bowser & Co., Inc.)

501. The Subject Of Internal-Bearing Lubrication may be conveniently treated under three headings. (Internal bearings are defined in Sec. 486.) (1) *Nature of the lubricant.* Engines oper-

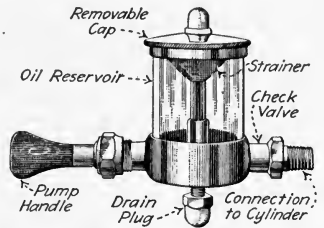

FIG. 536.—Typical hand push pump with glass body. (Detroit Lubricator Co.)

ating on wet steam require a lubricant which is not readily washed from the cylinder walls. Engines operating on superheated steam require a lubricant which will not carbonize or become too thin at the high superheat temperature; see Fig. 511. (2) *Appliance used to feed the lubricant.* This can be a hand pump (Fig. 536), a hydrostatic lubricator (Fig. 541), or a mechanical force-feed lubricator (Fig. 544). These appliances will be discussed in following sections. (3) *Manner of introducing the lubricant to the bearings,* discussed below.

502. The Most Preferable Manner Of Introducing Cylinder Oil is to mix it with the supply steam as the steam approaches

the engine. Unless the engine builders recommend some other scheme, the oil should be fed into the steam pipe above the throttle valve and thoroughly atomized before it reaches the cylinder. Feeding the oil through a pipe which does not extend into the interior of the steam pipe is apt to allow the oil to flow down the inner surface of the steam pipe without its being well mixed with the steam. A slotted pipe extending a "spoon-shaped" end well into the steam pipe (Fig. 537) will cause the steam to "spray" the oil through the slots and

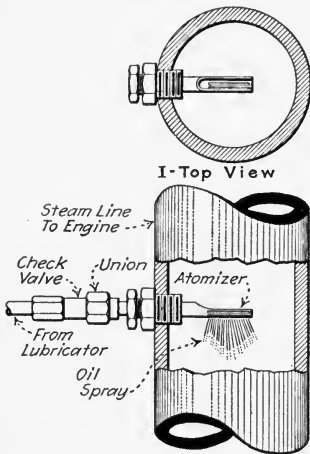

FIG. 537.—Atomizer for internal lubrication of steam engines. (This arrangement may be used with any internal-lubricating apparatus.)

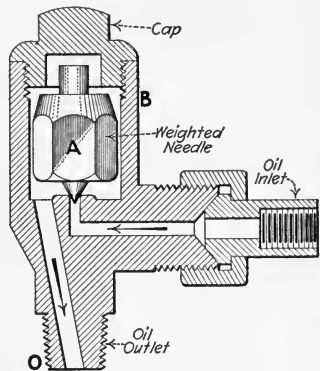

FIG. 538.—Gravity valve or oil check valve. (MacCord Mfg. Co. Weighted valve *A* is raised from its seat by oil which enters *B* and flows out at *O*. But oil flow in the opposite direction is prevented by *A*.)

thus to thoroughly atomize it. A check valve should be placed as shown to insure a steady flow of oil. Some provision should be made that a vacuum in the steam pipe will not draw the oil out of the feed pipe. A gravity valve (Fig. 538) or a suitable spring-loaded check valve will provide this assurance.

NOTE.—FLAKE GRAPHITE IS SOMETIMES FED TO THE VALVES AND CYLINDER, the object being to have the graphite "cake" on to the rubbing surfaces and glaze them, thus reducing the amount of oil necessary for good lubrication. Very small quantities of graphite, usually 1 to 3 per cent. by weight of the oil supplied, are fed, generally through

a separate graphite feeder, Fig. 539, and directly to the steam chest. Some force-feed lubricators will handle a mixture of graphite and oil. A separate graphite feeder is then unnecessary.

NOTE.—LUBRICATION OF THE STUFFING BOXES is usually accomplished by the oil introduced with the steam. Wherever metallic packing is used, however, it is customary to supply oil directly to the stuffing boxes through separate oil-feed pipes.

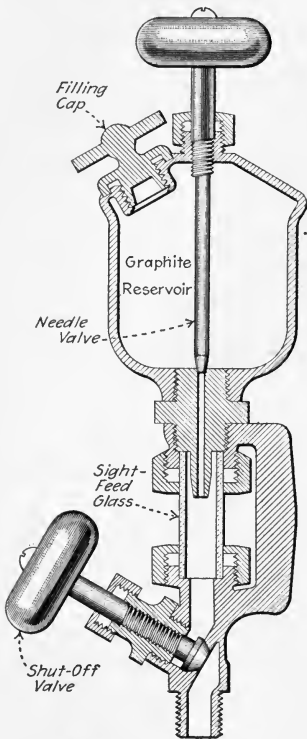

FIG. 539.—“Auxiliary” graphite feeder (Lunckenheimer Co.) for attachment to steam chest.

503. Feeding Oil To Internal Bearings By Hand is scarcely ever attempted except as a stand-by arrangement for use if the customary method of feeding becomes inoperative. A hand oil pump (Figs. 536 and 540) should, therefore, be placed on the cylinder oil-supply pipe of every engine and so arranged that it can be brought into service on very short notice.

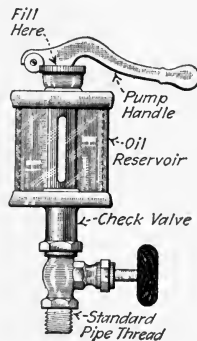

FIG. 540.—Lever-handle oil pump. (Lunckenheimer Co.)

504. The Principle Of The Hydrostatic Lubricator (Fig. 541) is a simple one. The pipe, *A*, is connected into the engine steam-supply pipe, 18 in. or more above the lubricator, and is also connected to a condenser, *C*. In pipe *A* and in *C* the steam which enters at *A* is condensed into water, which, when valve *B* is open, can flow through pipe *D*, down into the

bottom of the oil reservoir, *E*. This incoming water displaces oil which is forced out through pipe *F* and through the adjusting valve, *V*, which is simply for regulating the feed. The oil then rises through the water in the sight-feed glass, *S*, and enters the steam pipe, *R*, through the delivery pipe, *L*. The gage glass, *G*, shows the level of the oil in the reservoir. The oil is forced into *R* only by the column of water in and above *C*.

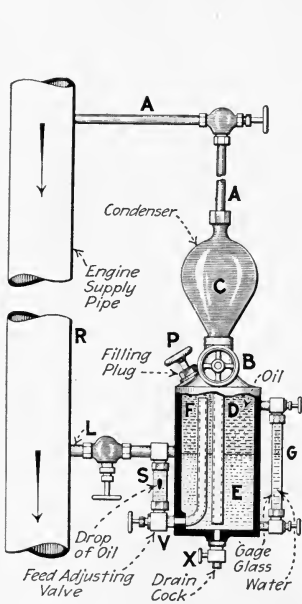

FIG. 541.—Hydrostatic lubricator.

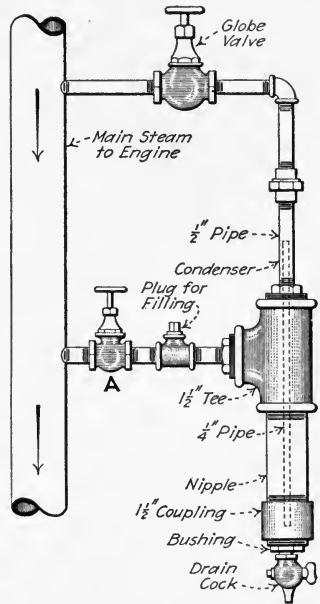

FIG. 542.—Hydrostatic lubricator constructed of pipe fittings. (A. O. Stone, in *Power House*, Jan. 20, 1920.)

The lubricator must be started and stopped with the engine, otherwise it would continue feeding and thereby waste oil. The rate of oil-feed depends on the viscosity of the oil and will, therefore, change with different room temperatures and each time the lubricator is refilled.

NOTE.—AN EMERGENCY HYDROSTATIC LUBRICATOR READILY MADE OF PIPE FITTINGS is shown in Fig. 542. Regulation of oil-feed is attained by adjustment of the valve, *A*. It is evident that such a lubricator, since it has no sight-feed glass, is not at all reliable. It is useful only as an emergency device. To equip this lubricator with a sight glass would

probably involve a cost such that it would be preferable to purchase a manufactured lubricator.

505. The Care And Operation Of Hydrostatic Lubricators are simple. In filling the lubricator valves *B* and *V*, Fig. 541, are closed; then drain cock *X* and plug *P* are opened. After all water has drained out of *E*, *X* is closed and fresh oil is poured into *P*. In cold weather it may be necessary to heat the oil to sufficiently reduce its viscosity that it will readily flow into the reservoir. Should the condenser, *C*, by any

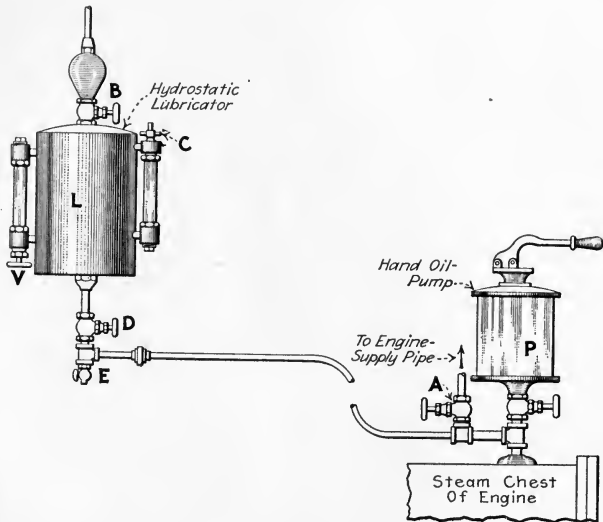

FIG. 543.—Scheme whereby a hand oil pump may be used for filling a hydrostatic lubricator. (W. R. Weiss in *Power*, Apr. 19, 1921. By connecting the pipe from *P* to the lubricator at *C* instead of at the bottom, an arrangement is secured with which the operation of the lubricator need not be stopped to fill it. Pumping oil into the lubricator will then force the water out through the steam pipe whence it will flow to the engine with the supply steam. If the pumping is done slowly, this small amount of water will not harm the engine.)

chance be drained of its water, sufficient time must be allowed for it to fill before opening *B* to the oil. Otherwise, steam would enter the oil and cause "churning" in the sight-feed glass. The only remedy for churning is to completely empty the lubricator, cool it, fill afresh, and wait for the condenser to fill with water. If the sight-feed glass gets smeared with oil, the cause may be that the drops are too

large for the bore of the glass tube. This can usually be remedied in one of three ways: (1) *Fit a larger diameter glass.* (2) *Solder a wire on to the nipple* (at which the drops form) to guide the oil drops centrally up the tube. (3) *Fill the sight-glass with salt water or glycerine.* The heavier specific gravity of these liquids will cause the oil to rise in smaller drops which will not touch the glass.

NOTE.—LEAKAGES OF JOINTS OR PACKING IN HYDROSTATIC LUBRICATORS MUST BE AVOIDED, because the lubricators are very sensitive and leaks are sure to interfere with their operation.

NOTE.—A METHOD OF FILLING A HYDROSTATIC LUBRICATOR WITH A HAND OIL PUMP is shown in Fig. 543, where an additional pet-cock, *C*, is shown mounted at the top of the gage glass. To refill the lubricator, *L*, it is first shut off in the usual manner by closing valves *B* and *V*. Cocks *C* and *E* and valve *D* are then opened, allowing the water to drain from the lubricator. *E* is then closed and oil is pumped from *P* to *L*, after which *D* and *C* are again closed. The lubricator is then ready for service.

506. To Prevent Trouble With Hydrostatic Lubricators

it is necessary to use only oil of good quality and to be sure that it is absolutely clean and free of all foreign substances. It is well to strain all of the oil used and to keep it well protected. Sometimes a lubricator cannot work because some of its small passages have become clogged with dirt from the oil. It is good practice to occasionally empty the lubricator and blow steam through it so as to thoroughly clean out any dirt or sediment that may have lodged in the small tubes or passages.

NOTE.—THE WATER FEED VALVE OF A HYDROSTATIC LUBRICATOR SHOULD BE LEFT OPEN WHEN THE ENGINE IS SHUT DOWN, as during the noon hour, and when the oil regulating valve is closed. The lubricator being connected above the engine throttle valve, steam enters the support arm and heats the oil in the body of the lubricator while the throttle is closed as well as while open. This heat causes the oil in the lubricator to expand. If the water feed valve is left open it acts as a vent, and some of the water in the bottom of the lubricator body will be forced up into the condenser. If the oil regulating valve and water feed are both shut, there will be no outlet for the expanding oil which may then exert such a pressure on the body as to cause it to bulge.

507. Mechanical Force-Feed Lubricators (Figs. 544 and 545) are coming into extensive use for internal lubrication of steam engines. In general, they are preferable to the hydro-

static lubricators because they are more positive in operation and furthermore they can be arranged to automatically start and stop with the engine. A great number of different kinds

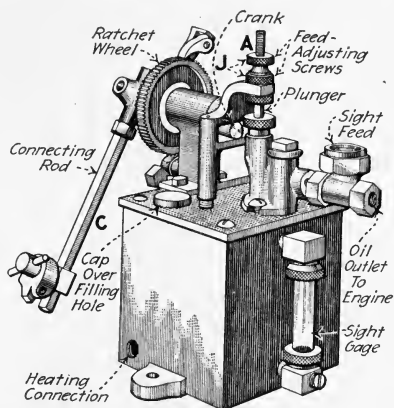

FIG. 544.—Exterior view of single-feed, metal-body, force-feed pump. (Hills-McCanna Co.)

are on the market. Most of them are very satisfactory. In the one shown (Figs. 544 and 545), the connecting rod, C,

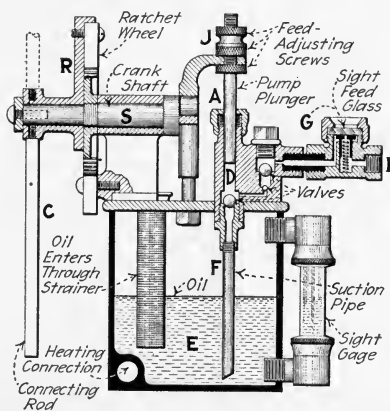

FIG. 545.—Section through force-feed lubricator. (Hills-McCanna Co.)

is driven from some part of the engine which has a reciprocating motion. The ratchet wheel, R, transforms this motion into rotation of the crank shaft, S, which again imparts reciprocating

eating motion to the plunger, *A*. On the upward stroke of *A*, oil is drawn up from the reservoir, *E*, (Fig. 545), through pipe *F* into the displacement chamber, *D*. From *D* it is forced on the downward stroke of *A*, past the sight glass, *G* and out through a pipe attached at *I*, to the engine. Adjustment of feed is accomplished by: (1) Varying the amount of movement of the connecting rod, *C*. (2) Varying the stroke of the plunger, *A*, by the screws, *J*.

NOTE.—MULTIPLE-FEED MECHANICAL LUBRICATORS are useful for supplying oil to more than one point. In compound engines a multiple-feed lubricator can be employed to furnish a separate supply of oil to each cylinder. A separate feed is also used to feed each stuffing box which is to be oiled. The number of feeds may be sufficient to supply every need of an entire plant with one lubricator, in which event the lubricator is motor- or steam-driven and the feed to each delivery point must be started and stopped by an attendant.

NOTE.—IN INSTALLING FORCE-FEED LUBRICATORS, the lubricator may be mounted on any convenient place on the engine. The engine builder or engineer will designate the most advantageous location. Installation should be made so that the sight feeds and filler plugs are in full view of the engineer. The ratchet arm can be driven by any reciprocating motion of the engine. Always use pipe free from rust. Before connecting up the valve, make sure that the lubricator is clean of all foreign matter and fill the lubricator reservoir with oil. Work the operating lever by hand to fill the oil pipe until it overflows. In this way the operator will know that the pipe line is clear.

508. The Proportional Lubricator Is A Modified Hydrostatic Lubricator and is intended to furnish internal lubrication for an entire plant; see Fig. 546. A reducing and enlarging (venturi), section, *A*, is placed in the main steam pipe from the boiler. The lubricator is installed to deliver oil at the reduced section, *A*. The condenser, *C*, however, is connected to the main portion, *B*, of the steam pipe. As steam flows through the steam pipe, the pressure at *A* will fall below that at *B*, due to the velocity of the steam. The greater the velocity of the steam, the greater will be the pressure difference between points *A* and *B*. This difference of pressure is utilized, in addition to the difference in specific gravity of the water in *C* and the oil in *F*, to force oil from the lubricator through the needle valve, *D*. Thus, the oil-feed will vary

with the velocity of the steam in the main pipe. This lubricator has the disadvantages of all hydrostatic lubricators and besides, unless the check valve, *E*, is properly spring-loaded, it may feed oil when no steam is flowing in *A*.

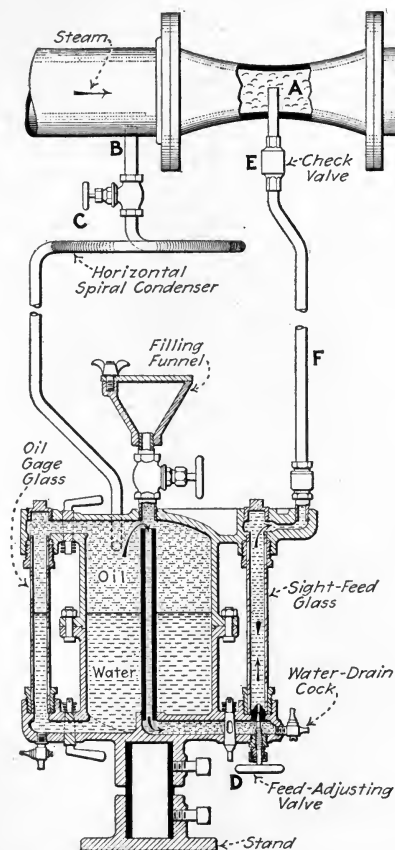

Fig. 546.—Meyerhng proportional lubricator. (Oil Well Supply Co., Pittsburgh.)

QUESTIONS ON DIVISION 16

1. What is the primary purpose of lubrication?
2. Define *friction*.
3. Explain *rolling friction*.
4. Explain *sliding friction*.
5. Explain *fluid friction*.
6. What happens when a fluid is introduced between two sliding surfaces?
7. Define *body* as applied to oils.

8. Define *viscosity* and explain with a sketch how it is measured.
9. What does the viscosity of an oil determine?
10. Does the viscosity of an oil ever change?
11. Explain the use of *solid lubricants*.
12. Name some substances which are solid lubricants.
13. What are *semi-solid lubricants* and what are their use?
14. Name three general classifications of oils (classified as to source of supply) and explain the properties of each.
 15. How is the *specific gravity* of an oil measured and what does it indicate?
 16. At what temperatures are oil viscosities usually measured?
 17. Define *flash point*, *fire point*, and *chill point*.
 18. How are the above *points* used in the selection of an oil?
 19. What are the *mechanical conditions* of a bearing and how do they affect the choice of an oil?
 20. How does the lubricating system which is used in an installation affect the selection of an oil for it?
 21. What are deposits in oils caused by?
 22. State the principal properties of circulation oils.
 23. State the principal properties of cylinder oils.
 24. What are the external and internal bearings of a steam engine?
 25. Define automatic and non-automatic lubrication of external bearings.
 26. Discuss the lubrication of external bearings by hand?
 27. Discuss *drop-feed lubrication*.
 28. What is the *bottle oiler* and how does it function? Explain with a sketch.
 29. Describe and, using a sketch, discuss *ring-oiled bearings*.
 30. What are the applications of drop-feed oiling?
 31. Describe and discuss *splash oiling*.
 32. Draw a diagram of a *gravity-circulation oiling system* and discuss its merits.
 33. Describe and discuss the *force-feed circulation system* of bearing lubrication.
 34. What are the relative merits of the three systems of Questions 31 to 33?
 35. Enumerate the methods of supplying oil to moving engine bearings and describe each.
 36. Describe, with a diagrammatic sketch, the operation of a good oil purifier.
 37. How should oil flow through cloth filter surfaces?
 38. How can water be automatically removed from a mixture of oil and water?
 39. How should oil be introduced to an engine for its internal-bearing lubrication?
 40. How may graphite be introduced to the internal bearings?
 41. How are the stuffing boxes lubricated?
 42. What is the field of hand oil-pumps?
 43. Draw a sketch and with it discuss the principle of the hydrostatic lubricator.
 44. Using the sketch of Question 43 show how a hydrostatic lubricator is refilled.
 45. What troubles are to be guarded against in using hydrostatic lubricators and how are they avoided?
 46. Describe the operation of a mechanical force-feed lubricator. Make a sketch and tell how to install a mechanical force-feed lubricator.
 47. What is the principle of the proportional lubricator?

APPENDIX

SOLUTIONS TO PROBLEMS

The Following Solutions To The Problems, which have been presented at the ends of the various divisions throughout the book, are included to assist the student. These solutions should be referred to only after the reader has made an earnest effort to solve, without assistance, the problem which is under consideration. If used in this way, these solutions may constitute a material aid. But if the reader refers to this appendix before he has made an honest effort to work out his own solution, then the material in this appendix will, probably, do more harm than good.

The Same Symbols And The Same Formulas Are Used in these solutions as those which are employed in the division which precedes the problems which are proposed in the text portions of the book.

SOLUTIONS TO PROBLEMS ON DIVISION 1

FUNCTION AND PRINCIPLE OF THE STEAM ENGINE

1. Head-end displacement volume = $(10 \times 10 \times 0.785) \times 12 = 942$ cu. in. Crank-end displacement volume = $942 - [(1.5 \times 1.5 \times 0.785) \times 12] = 920.8$ cu. in. Head-end clearance percentage = $185 \div 942 = 0.196$ or 19.6 per cent. Crank-end clearance percentage = $180 \div 920.8 = 0.195$ or 19.5 per cent.

2. From steam tables, the total heat of dry saturated steam at 160 lb. per sq. in. abs. = 1194.5 B.t.u. per lb. Also, the total heat of steam of 89 per cent. quality at 17 lb. per sq. in. abs. = $187.5 + (0.89 \times 965.6) = 1046.9$ B.t.u. per lb. By For. (1): Theoretical efficiency = $(\text{Heat abstracted}) \div (\text{Heat received}) = [(\text{Heat received}) - (\text{Heat rejected})] \div (\text{Heat received}) = [1194.5 - 1046.9] \div 1194.5 = 12.3$ per cent.

3. Area of piston = $9 \times 9 \times 0.785 = 63.6$ sq. in. Effective pressure = $125 - 4 = 121$ lb. per sq. in. Hence, by For. (3): $W = A_{ip} L_f P_m = 63.6 \times 1 \times 121 = 7696$ ft. lb. per working stroke. By For. (5): $P_{ihp} = P_m L_f A_{ip} N_s / 33,000 = (121 \times 1 \times 63.6 \times 200) \div 33,000 = 46.6$ h.p. for each end. Total horse power = $2 \times 46.6 = 93.2$ h.p.

4. By For. (6): $P_m = 0.9[K(P_g + 14.7) - P_a]$. Now, from Table 20:

$K = 0.737$. Also, $P_a = 4 + 14.7 = 18.7$ lb. per sq. in. abs. Hence, $P_m = 0.9[0.737(125 + 14.7) - 18.7] = 75.9$ lb. per sq. in. By For. (5): $P_{ihp} = P_m L_{fs} A_{ip} N_s / 33,000 = (75.9 \times 1 \times 63.6 \times 200) \div 33,000 = 29.2$ h.p. for each end. Total horse power = $2 \times 29.2 = 58.4$ h.p.

SOLUTIONS TO PROBLEMS ON DIVISION 3

INDICATORS AND INDICATOR PRACTICE

1. By the rules of Sec. 84, length of diagram = $4 \times 12 \div 13 = 3.69$ in. Radius of brumbo pulley = $13 \times 3 \div 12 = 3.25$ in.

2. Length of diagram = (diam. smaller pulley \div diam. larger pulley) \times stroke = $(2 \div 18)36 = 4$ in.

3. By method of ordinates, mean height crank-end diagram = 1.048 in. mean height head-end diagram = 1.006 in.

4. By For. (15) mean effective pressure = $P_m =$ mean height of diagram \times scale of spring. For head-end diagram: $P_m = 1.006 \times 60 = 60.36$ lb. per sq. in. For crank-end diagram: $P_m = 1.048 \times 60 = 62.88$ lb. per sq. in.

5. By For. (13) the h.p. constants are: For head end, $k_1 = \frac{L_{fs} A_{ip}}{33,000} = \frac{1.25 \times 12 \times 12 \times 0.7854}{33,000} = \frac{1.25 \times 113.1}{33,000} = 0.004284 = \frac{1}{233}$.

For crank end, $k_2 = \frac{1.25 \times (113.1 - 4.9)}{33,000} = \frac{1.25 \times 108.2}{33,000} = 0.0041 = \frac{1}{244}$. By For. (16), $P_{ihp} = P_m N k$. For head end, $P_{ihp} = 60.36$

$\times 220 \times \frac{1}{233} = 56.9$ h.p. For crank end, $P_{ihp} = 62.88 \times 220 \times \frac{1}{244} = 56.7$ h.p. Total for engine, $P_{ihp} = 56.9 + 56.7 = 113.6$ h.p.

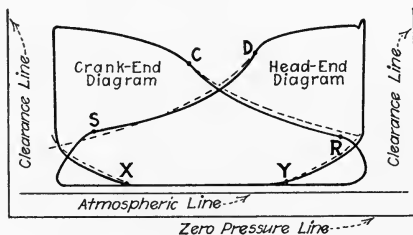

FIG. 547.—Solution to Prob. 6.

6. See Fig. 547 which shows the theoretical expansion and compression lines.

7. Expansion and compression curves show that piston and exhaust valves are probably in good order but that there is steam leaking into the crank end during expansion. Admission is early at the head end. The steam lines show a marked slope probably because the engine is under heavy load.

8. By For. (21) the steam rate is

$$W_{ih} = \frac{13,750}{P_m} [(x_s + x_c)D'_{ps} - (x'_s + x_c)D''_{ps}] \text{ lb. per i.h.p. hr.}$$

The length of the diagrams in Fig. 116 is $3\frac{1}{4}$ in. Values of x_s and x'_s are found by dividing the distance of a point from the end of the diagram by $3\frac{1}{4}$ in. x_c is given in Prob. 6 as 0.15. Pressures at points are taken from the diagrams. Densities are from the steam table. Values of P_m were found in Prob. 4. Values of the several terms in the formula are arranged tabularly below.

Point.....	R	S	X	Y
Distance from end of diagram (in.)..	3.00	2.80	0.75	0.83
x_s or x'_s	0.923	0.862	0.231	0.256
Pressure (lb. per sq. in. abs.)	50	55	21	22
Density (lb. per cu. ft.).....	0.1175	0.1285	0.0521	0.0545

Substituting in For. (21), for head end:

$$W_{ih} = \frac{13,750}{60.36} [(0.862 + 0.15)0.1285 - (0.256 + 0.15)0.0545] = 228$$

$$[1.012 \times 0.1285 - 0.406 \times 0.0545] =$$

$$228(0.1301 - 0.0221) = 228 \times 0.108 = 24.6 \text{ lb. per i.h.p. hr.}$$

For crank end:

$$W_{ih} = \frac{13,750}{62.88} [(0.923 + 0.15)0.1175 - (0.231 + 0.15)0.0521] = 218.7$$

$$[1.073 \times 0.1175 - 0.381 \times 0.0521] =$$

$$218.7(0.1261 - 0.0198) = 218.7 \times 0.1063 = 23.25 \text{ lb. per i.h.p. hr.}$$

9. By the rule of Sec. 131 and from the results of Probs. 5 and 8, total steam used per hour = $(56.9 \times 24.6) + (56.7 \times 23.25) = 1399 + 1318 = 2717$ lb. per hr.

10. By planimeter, area of head-end diagram = 3.23 sq. in.; area of crank-end diagram = 3.38 sq. in. By For. (14), head-end $P_m = \frac{3.23 \times 60}{3.25} = 59.6$ lb. per sq. in. Crank-end $P_m = \frac{3.38 \times 60}{3.25} = 62.4$ lb. per sq. in.

SOLUTIONS TO PROBLEMS ON DIVISION 6

FLY-BALL STEAM-ENGINE GOVERNORS, PRINCIPLES AND ADJUSTMENT

1. By For. (25), the coefficient of regulation of the governor, $M_r = \frac{N_n - N_f}{N_f} = (201 - 197) \div 197 = 0.0203 = 2.0$ per cent.

2. By For. (27), the height, $L_{ht} = \frac{35,200}{N^2} = \frac{35,200}{87^2} = 4.66$ in.

3. By For. (26), the centrifugal force, $F_c = 0.000,028,5Wr_iN^2 = 0.000,028,5 \times 6.25 \times 4.32 \times 500^2 = 192.4$ lb.

4. The governor speed remains constant. The number of revolutions of the governor per engine revolution will be proportionally less to allow the additional engine speed. That is, the revolutions will be $3.7 \times \frac{105}{125} = 3.1$ revolutions per engine revolution. For a decrease in the speed ratio, the size of the driving pulley must be proportionally decreased, that is, $14 \times \frac{105}{125} = 11\frac{3}{4}$ in. = the required diameter.

5. Substituting in For. (28), $L_{hi} = \frac{W + W_1}{W} \times \frac{35,000}{N^2}$, there results:
 $16 = \frac{12 + 145}{12} \times \frac{35,200}{N^2}$ from which: $N^2 = 28,800$ and $N = 170$ r.p.m.

SOLUTIONS TO PROBLEMS ON DIVISION 8

COMPOUND AND MULTI-EXPANSION ENGINES

1. For the condensing engine, by Sec. 287, the receiver pressure = supply pressure \div cylinder ratio = $(150 + 14.7)/4.3 = 38.3$ lb. per sq. in. abs., or $38.3 - 14.7 = 23.6$ lb. per sq. in. gage. For the non-condensing engine, the receiver pressure = $\sqrt{\text{supply pressure} \times \text{back pressure}} = \sqrt{(100 + 14.7) \times (5 + 14.7)} = 47.5$ lb. per sq. in. abs., or $47.5 - 14.7 = 32.8$ lb. per sq. in. gage.

2. Force on piston = $(10 \times 10 \times 0.785) \times 150 = 11,780$ lb. By Sec. 273: Torque = $0.90 \times 11,780 \times 6 = 63,600$ lb. in.

3. Absolute pressure in condenser = $(30 - 28.5) \times 0.491 = 0.74$ lb. per sq. in. From steam tables: steam temperature at 0.74 lb. per sq. in. abs. = 92 deg. fahr. Steam temperature at $(225 + 14.7) = 239.7$ lb. per sq. in. abs. = 397 deg. fahr. Hence, the temperature range in each cylinder = $(397 - 92) \div 4 = 76.2$ deg. fahr.

4. Neglecting clearance, the ratio of expansion = $4.5 \div 0.26 = 17.3$. Considering clearance ratio of expansion = $[4.5 + (0.06 \times 4.5)] \div (0.26 + 0.06) = 4.77 \div 0.32 = 14.9$.

5. By Sec. 291, lead = $5 \times \frac{1}{16} = \frac{5}{16}$ in.

SOLUTIONS TO PROBLEMS ON DIVISION 10

STEAM-ENGINE EFFICIENCIES AND HOW TO INCREASE THEM

1. By For. (29), the efficiency of the ideal Rankine cycle,

$$E_{dt} = \frac{H_{t1} - H_{t2}}{H_{t1} - H_{t2}}$$

The total heats, H_{t1} and H_{t2} , are, by a temperature-entropy chart, 1190

and 1003 B.t.u. per lb. The heat of liquid, $H_{12} = 180$ B.t.u. per lb. Hence,

$$E_{dt} = \frac{1190 - 1003}{1190 - 180} = 0.185 = 18.5 \text{ per cent.}$$

2. By For. (30), the *Rankine cycle water rate*,

$$W_s = \frac{2545}{H_{11} - H_{12}}$$

The steam pressure of 150 lb. per sq. in. gage corresponds to 366 deg. fahr. for saturated steam. The steam, therefore, has $550 - 366 = 184$ deg. fahr. superheat. By the temperature-entropy chart, H_{11} and $H_{12} = 1295$ and 955 . Hence,

$$W_s = \frac{2545}{1295 - 955} = 7.20 \text{ lb. per h.p. hr.}$$

3. By For. (31), the *thermal efficiency*,

$$E_{dti} = \frac{2545}{W_{si}(H_{11} - H_{12})}$$

By For. (32), the *total heat at admission*,

$$H_{11} = x_d H_v + H_l = 0.98 \times 853 + 343 = 1179 \text{ B.t.u. per lb.}$$

The *heat of liquid at exhaust*, H_{12} (from a steam table) = 180 B.t.u. per lb. Hence,

$$E_{dti} = \frac{2545}{18.5(1179 - 180)} = 0.138 = 13.8 \text{ per cent.}$$

4. The *actual thermal efficiency of the engine* in Prob. 1, by For. (31) =

$$E_{dti} = \frac{2545}{W_{si}(H_{11} - H_{12})} = \frac{2545}{25(1190 - 180)} = 0.101 = 10.1 \text{ per cent.}$$

By For. (34), the *Rankine cycle ratio* =

$$\frac{\text{Actual thermal efficiency}}{\text{Efficiency of the ideal Rankine cycle}} = \frac{10.1}{18.5} = 0.55.$$

5. By For. (35), the *mechanical efficiency*,

$$E_{dm} = \frac{P_{bhp}}{P_{ihp}} = \frac{175}{198} = 88.4 \text{ per cent.}$$

6. By For. (36) the *over-all efficiency*,

$$E_{dub} = \frac{2545}{W_{sb}(H_{11} - H_{12})}$$

By For. (33), the *total heat of the steam admitted*,

$$H_{11} = H_d + T_n C_m = 1196 + 100 \times 0.58 = 1254 \text{ B.t.u. per lb.}$$

The absolute back pressure = $29.8 - 27 = 2.8$ in. of mercury or $2.8 \div 2.03 = 1.4$ per sq. in. abs. The heat of liquid at this back pressure, $H_{12} = 81$ B.t.u. per lb. Hence the *over-all efficiency*,

$$E_{dub} = \frac{2545}{17.4(1254 - 81)} = 0.125 = 12.5 \text{ per cent.}$$

7. By For. (38), the *British thermal units per brake horse power hour* = $W_{sb}(H_{11} - H_{12}) = 17.4(1254 - 81) = 20,400$ B.t.u. per b.h.p. hr. or $20,400 \div 0.746 = 27,300$ B.t.u. per kw. hr.

8. By For. (31), the thermal efficiency,

$$E_{dti} = \frac{2545}{W_{si}(H_{i1} - H_{i2})} = \frac{2545}{19(1190 - 180)} = 13.25 \text{ per cent.}$$

for the first engine.

$$E'_{dti} = \frac{2545}{18(1200 - 180)} = 13.85 \text{ per cent.}$$

for the second engine. The engine using 18 lb. of steam per indicated horse power hour is, in this case, the more efficient.

SOLUTIONS TO PROBLEMS ON DIVISION 12

STEAM-ENGINE TESTING

1. By the rule of Sec. 368, the *mechanical efficiency* = *brake horse power* ÷ *indicated horse power* = 120/133 = 0.903. *Friction horse power* = *indicated horse power* - *brake horse power* = 133 - 120 = 13 h.p.

$$\begin{aligned} 2. \text{ By For. (41), the brake horse power} &= P_{bhp} = \frac{2\pi L_f N(W - W_1)}{33,000} \\ &= \frac{2 \times 3.14 \times 5.25 \times 220 \times (250)}{33,000} = 55 \text{ b.h.p.} \end{aligned}$$

$$\begin{aligned} 3. \text{ By For. (61), the brake constant} &= k_b = \frac{2\pi L_f}{33,000} = \frac{2\pi \times (3 + 0.031)}{33,000} \\ &= 0.000,577. \end{aligned}$$

$$\begin{aligned} 4. \text{ By For. (54), the pounds of dry steam supplied per hour} &= W_{sd} \\ &= x_d W_{sw} = 0.97 \times 5000 = 4850 \text{ lb.} \text{ From For. (55), the water rate} \\ &= W_{sdi} = \frac{W_{sd}}{P_{ihp} \times t_h} = \frac{4850}{200 \times 1} = 24.25 \text{ lb. dry steam per i.h.p. per hr.} \end{aligned}$$

$$\begin{aligned} 5. \text{ From the example under Sec. 373, it was found that 2499 lb. of} \\ \text{dry steam were used per hour. By For. (51), the horse power input to} \\ \text{the generator (brake horse power when belt slip is neglected)} &= P_{hp} \\ &= \frac{P_{kw}}{0.746 E_d} = \frac{20.2 + 30.7}{0.746 \times 0.90} = 75.8 \text{ h.p.} \text{ By For. (56), the water rate} = \end{aligned}$$

$$W_{sdb} = \frac{W_{sd}}{P_{bhp} \times t_h} = \frac{2499}{75.9 \times 1} = 33.0 \text{ lb. of dry steam per b.h.p. per hr.}$$

Since there are 2550/75.8 or 33.6 lb. of wet steam used per brake horse power per hour the thermal efficiency is, by For. (36) Div. 10,

$$\begin{aligned} E_{dtb} &= \frac{2545}{W_{svb}[(x_d H_v + H_i) - H_{i2}]} = \frac{2545}{33.6[(0.98 \times 856.8 + 338) - 192.6]} = \\ &= \frac{2545}{33.6(985.4)} = 0.0769 = 7.7 \text{ per cent. thermal efficiency based on brake} \\ &\text{horse power.} \end{aligned}$$

6. From Sec. 368, the brake horse power = 0.90 × 200 = 180 b.h.p.

The weight of wet steam used per hour per brake horse power = $42,000/10 \times 180 = 23.3$ lb. By For. (36), the thermal efficiency =

$$E_{dtb} = \frac{2545}{W_{sub}[(x_d H_v + H_i) - H_{i2}]} = \frac{2545}{23.3[(0.99 \times 838 + 361.2) - 203]} = \frac{2545}{23.3(987.82)} = 0.1106 = 11.1 \text{ per cent. thermal efficiency based on brake horse power.}$$

SOLUTIONS TO PROBLEMS ON DIVISION 15

SELECTING AN ENGINE

1. The energy units developed per year = $10 \times 300 \times 250 = 750,000$ h.p. hr. By For. (63): Cost per unit of energy = Total expenses per year \div Energy units developed per year = $\$15,000 \div 750,000 = \0.02 per h.p. hr. or 2 ct. per h.p. hr.

2. By Sec. 443, depreciation charge = $\$5000 \div 28 = \178.60 .

3. DAILY QUANTITIES:

LOAD	HOURS SERVICE	H.P. HR.	LB. STEAM, CORLISS	LB. STEAM, UNIFLOW
$1\frac{1}{4}$	3	3,750	93,400	78,700
Rated	1	1,000	23,900	20,100
$\frac{3}{4}$	$5\frac{1}{2}$	4,125	95,000	80,900
$\frac{1}{2}$	$3\frac{1}{2}$	1,750	41,850	34,300
$\frac{1}{4}$	12	3,000	87,000	60,900
Totals	24	13,625	341,150	274,900
Cost of steam @ 50 ct. per 1000 lb.....			\$170.58	\$137.45
Other operating costs at \$1.50 per hr.....			36.00	36.00
Total daily operating costs.....			\$206.58	\$173.45

YEARLY QUANTITIES:

Energy units delivered = $300 \times 13,625 = 4,087,500$ h.p. hr.		
Operating charges, $\left\{ \begin{array}{l} 300 \times 206.58 \dots\dots\dots \$61,974 \\ 300 \times 173.45 \dots\dots\dots \end{array} \right.$		\$52,035
Fixed charges at 15 per cent.....	1,500	1,950
Total annual costs.....	\$63,474	\$53,985
Unit energy costs (per h.p. hr.) = $\frac{63,474}{4,087,500}$	\$0.0155	
	$= \frac{53,985}{4,087,500}$	\$0.0132

3. From Prob. 3:

	CORLISS	UNIFLOW
Daily operating costs.....	\$ 206.58	\$ 173.45
Operating costs for 15 days.....	3,098.70	2,601.75
Annual Fixed charges.....	1,500.00	1,950.00
	<hr/>	<hr/>
Total annual costs.....	\$4,598.70	\$4,551.75

Therefore, uniflow engine would have smaller annual cost.

Energy output in 15 days = $15 \times 13,625 = 204,375$ h.p. hr. *Cost per unit of energy* = $\$4,551.75 \div 204,375 = \0.0223 per h.p. hr.

INDEX

A	PAGE		PAGE
Absorption dynamometers, classification.....	347	Automatic Furnace Company, Model Acme engine trunk piston mechanism.....	35
ACCEPTANCE TEST, definition.....	365	Auxiliaries, inspection.....	375
how conducted.....	443	Auxiliary piping and equipment, non- condensing engine, illustration.....	375
Adiabatic expansion.....	16	B	
Admission line, variations, illustration.....	61	Babbitting, engine bearings.....	396
Advance angle.....	99	Babbitt recess, method of closing, gating and venting.....	398
Air leaks, source of trouble in con- densing operation.....	382	BACK-acting crank-mechanism.....	34
Alignment, engine, method used in erection and re-assembling..	407	pressure, purpose of reducing with condenser.....	285
Allis-Chalmers heavy-duty Corliss engine, valve gear, illustration.....	158	BALANCED multiported valve.....	91
American-Ball engine governor, illus- tration.....	250	SLIDE VALVE, advantages and disadvantages.....	89
American Injector Company, crank- pin oiler, illustration.....	463	definition.....	26
AMERICAN SOCIETY MECHANICAL ENGINEERS, "Test Code," dry steam basis for com- puting engine efficiency.....	304	repair.....	394
"Test Code" outline.....	369-371	Ball Engine Company, tandem- compound engine, illustration.....	24
water-rate test specifications... ..	365	BALL four-valve Corliss engine, valve-gear, illustration.....	174
American Steam Gage and Valve Company, Thompson indi- cator, illustration.....	40	governor, height when revolving..	205
AMES "controlled-compression una- flow" engine, illustration.....	162	"Banjo" crank-pin oiler, illustration..	471
engine, Robb-Armstrong-Sweet governor, illustration.....	249	BEARINGS, adjustment to compen- sate for wear.....	400
four-valve non-releasing Corliss engine, valve gear, illustration.....	150	engine, temperature after run- ning short time.....	379
"UNA-FLOW" ENGINE directions for setting poppet valves.....	182-186	EXTERNAL, definition.....	460
effect of valve gear adjust- ments, table.....	187	drop-feed lubrication.....	461
AMES IRON WORKS, directions for setting poppet valves on Ames "una-flow" engine.....	182-186	lubrication by hand.....	460
portable boiler and engine unit, illustration.....	322	freshly re-babbitted, peening... ..	397
valve gear of Ames four-valve engine, illustration.....	150	friction in engines.....	301
Ammeter, use in determining output of generator.....	354	heating, causes.....	402
Amsler polar planimeter, illustration..	73	high pressure, oil required.....	455
ANGLE-compound engine, definition..	25	inaccessible, feeler for detecting heat.....	380
of advance, definition.....	99	inspection.....	374
ANGULARITY, connecting rod, defini- tion and effects.....	101	INTERNAL, definition.....	460
eccentric rod, definition.....	102	oil feeding by hand.....	480
Ashcroft Manufacturing Company, Coffin planimeter, illustration.....	75	loose, knocks caused by.....	410
Atmospheric line, indicator card, how drawn.....	58	MAIN, see also <i>Main bearing</i> . illustration.....	302
AUTOMATIC cut-off governor.....	228	re-babbitting boxes of.....	396
ENGINE, definition.....	228	mechanical conditions.....	455
reversing inadvisable.....	235	method of scraping high spots, illustration.....	400
lubrication systems for external bearings, merits.....	470	oil, table of uses and viscosities... ..	459
		re-babbitting.....	395
		ring-oiled.....	464
		scrapping.....	399
		SPLIT, illustration.....	374
		adjustment.....	401
		surfaces, reason for use of oils between.....	449
		wrist-pin or crank-pin, heating..	403
		Bentley, F. W. Jr., sight feed for drop-feed oiler, illustration..	464
		BOILER feed-water, equipment for weighing.....	361
		foaming, danger with super- heater.....	425
		PRESSURE, increased, effect on engine efficiency, graph.....	294

	PAGE		PAGE
BOILER PRESSURE new plant, how selected.....	436	CHUSE ENGINE AND MANUFACTURING COMPANY, Corliss - valve mechanism positively operated, illustration.....	29
stationary power plants, practical limits.....	295	engine indicator diagram.....	329, 331, 332
BOTTLE OILER.....	463	governor, illustration.....	239
illustration.....	465	uniform engine, illustration.....	330
Bowser oil filtering outfit, operation..	477	VALVE setting in condensing uniform engines.....	188
Bowser, S. F., and Company, Incorporated, filtering and circulation oil system, illustration.....	468	stem adjustment, illustration.....	111
Bradley, Alexander, on savings effected by superheating supply steam, table.....	423	CLEARANCE, inside, slide valve, definition.....	95
BRAKE ARM, effective length, definition.....	349	definition.....	2
rope brake, illustration.....	351	proper amount between journal and bearing.....	402
BRAKE constant, formula for calculating.....	368	typical values in different type engines, table.....	297
HORSE POWER calculation when using absorption dynamometer, formula.....	349	VOLUME, definition.....	2
absorption by water brake... ..	352	determined in engine testing..	366
computation from indicator diagrams, formula.....	78	effect on engine efficiency....	296
definition.....	78	Cleveland open-cup tester for flash- and fire-point tests, illustration.....	454
thermal efficiency based on formula.....	310	Coffin planimeter, illustration.....	75
net-weight.....	349	Collins, Hubert E., "Shaft Governors," on shaft governor operation.....	239
tare-weight, definition.....	348	COMPOUND ENGINE.....	258-282
Brakes, classification.....	347	advantages and disadvantages.....	260
Bridge and Beach Manufacturing Company, engine, indicator diagram.....	332	application.....	258
Brown and Sharpe Company, steel scale with end graduations..	122	classification according to method of transfer of steam.....	267
Brunbo pulley, definition.....	46	condensing operation.....	387
Buckeye Engine Company, "Buckeye-mobile," illustration... ..	334	correct receiver pressure necessary for economical operation.....	276
BUCKEYE ENGINE, effect of superheat graph.....	423	definition.....	23
governor.....	251	excessive cylinder condensation avoided by.....	261
piston-type riding-cut-off valve.....	135	how governed.....	225
"BUCKEYE-MOBILE" engine unit, illustration.....	334	indicated horse power computation.....	275
performance graphs.....	335	marine, forced-feed lubrication, illustration.....	470
type of power plant.....	333	mechanical efficiency greater than that of simple engine... ..	264
By-pass automatic valves, on condensing engines.....	184	most profitable degree of vacuum.....	289
		operation through large temperature and pressure ranges	258
C		receiver pressure dependent on cylinder ratio.....	278
Calculations, indicator, see <i>Indicator</i> .		reduced leakage loss, explanation.....	264
Cam, oscillating, poppet valve motion given by.....	161	saturation line.....	272
Center-crank engine, definition.....	20	saving greater at higher boiler pressure.....	260
CENTRIFUGAL FORCE, definition.....	194	single valve, uses.....	323
developed in revolving governor weight, formula....	205	stopping.....	387
governor.....	204	terms used in connection with..	271
permanent control in shaft governors effected by.....	230	testing.....	366
shaft governor operation.....	229	torque or turning moment, evenness increased.....	265
Centripetal force, definition.....	195	typical piping, illustration.....	386
Circulation oils, table of properties... ..	456	use of superheated steam.....	424
CHANDLER AND TAYLOR COMPANY, piston valve, illustration.....	27	valve setting.....	280
splash-oiled engine, illustration..	466	without by-pass valve, starting.....	387
engine, Armstrong governor, illustration.....	249	COMPRESSION curve, effect of clearance volumes on.....	68
variable speed engines, trigger device for secondary speed control.....	200	effect of different exhaust pressures on.....	69
Chill point of oil.....	455	Condensation, cylinder, see <i>Cylinder condensation</i> .	
CHUSE ENGINE AND MANUFACTURING COMPANY, condensing uniform engine, valve setting... ..	188	CONDENSER, barometric, several engines operated with.....	376

	PAGE		PAGE
CONDENSER, definition.....	283	CORLISS VALVE, advantages.....	146
ejector-jet, Corliss engine, illustration.....	284	dash pot, illustration.....	159
inspection.....	375	definition.....	28
low-level jet, connected to engine, illustration.....	286	detaching mechanism or trip gear, typical designs.....	155
starting and stopping.....	381	engine efficiency increased by.....	146
surface, connection to tandem-compound engine, illustration.....	284	GEAR, illustration.....	151
CONDENSING ENGINE, see also <i>Engine, condensing</i> .		inverted vacuum dash-pot, illustration.....	412
application.....	290	MECHANISM, non-releasing or positively operated, definition.....	30
definition.....	36	positively operated, description.....	149
CONDENSING OPERATION.....	283-290	moderate superheat advisable.....	421
adequate water supply necessary.....	286	reason for employing.....	146
advantages and disadvantages.....	289	releasing mechanism, illustration.....	152
change to non-condensing.....	382	repair.....	395
compound engine.....	387	typical designs.....	146
definition.....	283	TRIP GEAR, Vilter engine, illustration.....	156
importance of cylinder condensation in determining economy.....	287	Nordberg Manufacturing Company, illustration.....	156
methods of calculating power increase due to.....	285	COUNTERFLOW ENGINE, definition.....	32
non-condensing, indicator cards.....	285	saturated steam operation, economics, table.....	312-313
trouble caused by air leaks.....	382	using superheated steam, oil supplied by atomization method.....	422
when not economical.....	286	CRANK-end dead center, definition, illustration.....	103
CONNECTING ROD, angularity or obliquity, definition.....	101	MECHANISM, back-acting, illustration.....	34
bearing, illustration.....	302	standard, definition.....	34
Constants, engine and brake.....	368	PIN BEARING, heating.....	403
Cooper Corliss engine, heat-insulated cylinder, illustration.....	299	wedge and shims for adjustment illustration.....	400
Cord, indicator, method of arranging, illustration.....	59	PIN OILER, illustration.....	463
CORLISS cross-compound condensing engine, manufacturer's performance specifications.....	442	truing up without removing... use of in shaft governor in place of eccentric.....	239
detaching valves, dash pots for..	155	Crosby outside-spring indicator, illustration.....	43
ENGINE, compound, starting... cut-off, danger of lengthening.....	386	CROSS-COMPOUND Corliss engine governor, receiver-pressure regulation device, illustration..	277
detaching, stopping.....	172	ENGINE, definition.....	24
effects of valve-gear adjustments, table.....	170-171	driving alternator, illustration	268
ejector-jet condenser, illustration.....	284	CROSSHEAD shoes, method of adjusting, illustration.....	401
four-valve application.....	324	velocity variations during stroke	103
governor, starting block.....	385	Curved-slot pencil mechanism.....	43
hook-rod or reach-rod, illustration.....	383	CUT-OFF, apparent, definition.....	16
ideal steam line in.....	63	Corliss engine, danger of lengthening.....	172
indicator card.....	70	valve operating-mechanism, McIntosh and Seymour engine, illustration.....	94
influence of superheat on water-rate, graph.....	423	CYCLE, engine, definition.....	305
load increased.....	173	ideal Rankine.....	7
leads, laps and trial compressions table.....	169	CYLINDER CONDENSATION, causes and prevention.....	297
manufacturer's performance specifications.....	441	important in determining economy of condensing operation	287
method of governing.....	195	rejection and thermal losses partly caused by.....	297
non-releasing, starting and stopping.....	380	CYLINDER diagrams superimposed upon steam-chest diagrams.....	64
positively-operated, advantages and disadvantages....	149	EFFICIENCY, definition.....	303, 373
running over, how started.....	384	inspection.....	373
SIMPLE detaching, starting.....	383	OIL, best method of introducing, compounded with acidless tal-low oil.....	458
single-eccentric detaching, valve-setting directions 163-169	163-169	consumption per brake horsepower, graph.....	432
starting lever and wrist plate, illustration.....	384	engines using superheated steam.....	421
valve setting.....	163		
releasing gear, dash-pot, troubles	412		
VALVE.....	146-191		

	PAGE		PAGE
CYLINDER OIL, grades, table.....	458	ECCENTRICITY, definition.....	98
properties, table.....	458	relation to valve travel.....	99
ratio, compound engine, definition.....	271	EFFICIENCY, heat of liquid basis of calculation.....	306
D			
D-SLIDE VALVE, definition.....	26	steam-engine, how increased 291-317	306
disadvantages partially overcome.....	88	theoretical, formula.....	6
repair.....	393	ELECTRICAL load, measuring in poly-phase systems.....	356
DASH-POT, Corliss releasing gears, troubles.....	412	loading of engine.....	353-357
definition and purpose.....	211	output, direct-current generator, determination.....	354
detaching Corliss valves.....	155	ENERGY balance, electric-energy distribution circuits, illustration.....	300
DEAD CENTER, definition, illustration	103	cost, factors.....	428
trammel method of finding, illustration.....	104	electrical, heat unit equivalent.....	5
"Design and Construction of Heat Engines," W. E. Ninde, on valve diagrams.....	84	mechanical, heat unit equivalent.....	5
Design-determined equal leads, definition.....	114	ENGINE alignment, method.....	406-408
DETACHING-CORLISS-VALVE engine, advantages and disadvantages.....	153	angle-compound, illustration.....	25
MECHANISM, elements.....	153	annual depreciation.....	431
illustration.....	30, 152	application of indicator.....	57
single-and double-eccentric.....	154	automatic, reversing inadvisable	235
Detroit Lubricator Company, hand push pump, illustration.....	478	bearings, temperature after running short time.....	379
DIAGRAM, ideal indicator, illustration	60	center-crank, definition.....	20
INDICATOR, see <i>Indicator diagram</i> .		cleaning.....	388
leaky exhaust valve revealed by	66	clearance values, table.....	297
method of taking.....	58	COMPOUND, see also <i>Compound engine</i> .	
DIRECT measurement, valve setting	108	and multi-expansion.....	387
slide valve.....	87	four-valve, steam rates.....	329
DISPLACEMENT, slide valve, definition	101	single-valve, uses.....	323
" volume, formula.....	3	CONDENSING and non-condensing, steam consumption, table.....	286
DOUBLE-acting engine, definition.....	11	application.....	290
beat poppet valve, definition.....	160	definition.....	36
ECCENTRIC DETACHING CORLISS-VALVE engine, valve setting.....	172	operation, definition.....	283
mechanism, features.....	154	constants, calculation.....	368
engine, definition.....	23	Corliss, see <i>Corliss engine</i> .	
flow engine, definition.....	32	cost per unit of energy, factors considered in computing.....	428
stroke, definition.....	11	counterflow or double-flow, definition.....	32
Drains, inspection.....	376	cross-compound, illustration.....	24
DROP-cut-off Corliss-valve mechanism, illustration.....	152	CYCLE, definition.....	305
FEED lubrication of external bearings.....	461	effects of slide valve adjustments, table.....	112
oil cup with sight feed, illustration.....	462	data form.....	413
oiler, homemade sight feed, illustration.....	464	depreciation, causes.....	430
Dummy flywheel method, tare-weight of brake found by.....	348	direction of rotation.....	22
Duplex-compound engine, definition.....	24	DOUBLE-acting, definition.....	11
DYNAMOMETERS, absorption, classification.....	347	definition.....	23
classification.....	346	duplex-compound, illustration.....	24
fluid-friction type, operation.....	352	ECONOMY, affected by clearance volume.....	296
Prony brake type, construction and use.....	347	vs. maintenance charges.....	293
rope brake absorption type.....	350	with saturated steam, table.....	316-317
E			
ECCENTRIC circle.....	98	EFFICIENCY BASED ON BRITISH THERMAL UNITS PER kilowatt hour.....	304
crank-end extreme position illustration.....	120	brake horse power hour.....	304
head-end extreme position, illustration.....	120	EFFICIENCY BASED ON POUNDS OF COAL PER brake horse power hour.....	304
mechanism, illustration.....	97	pounds of coal per kilowatt hour.....	304
motion derived from.....	98	EFFICIENCY compared to ideal Rankine cycle.....	309
rod, angularity, definition.....	102	factors determining.....	291
setting on center.....	106	heat of liquid basis of calculation.....	306
		increased by Corliss and Poppet valves.....	146
		mechanical.....	304

	PAGE		PAGE
ENGINE efficiency, other measures of,		ENGINE, residual or scrap value....	431
formulas.....	310	riding-cut-off valve type, uses....	324
standards, chart.....	303	right hand, illustration.....	21
energy cost in selecting.....	439	RUNNING over, definition.....	22
EXPENSE, insurance cost.....	429	UNDER, definition.....	22
rent charged in proportion to		knocks in guides.....	412
floor space.....	429	saving effected by superheating	
taxes.....	430	supply steam, table.....	423
factors determining selection.....	434	SELECTION.....	427-446
fitted with pantograph and indi-		chart.....	440
cators, illustration.....	47	determination of speed desired	435
FIXED charges.....	428	for given service, procedure....	427
cut-off, definition.....	36	for new plant.....	434
four-valve type, construction		governed by cost per unit of	
and use.....	324	energy delivered.....	427
friction.....	301	operating characteristics	
getting out of line, definition,		affecting.....	437
causes.....	405	proper horse power determina-	
gridiron-valve, features.....	91	tion.....	435
heat conversion in.....	5	with reference to operating	
HIGH-pressure, definition.....	36	conditions.....	436
SPEED, definition.....	36	SHAFT-GOVERNED piston-valve,	
indicator diagram.....	62	setting valve for design-	
horizontal, illustration.....	21	determined equal leads,	
in line.....	406	example.....	123-125
inclined, illustration.....	21	valve setting.....	114
indicator springs selection.....	55	short-stroke definition.....	32
indicators, see also <i>Indicators</i>		side-crank, definition.....	20
40-83		SIMPLE, definition.....	22
inspection.....	373-377	detaching Corliss-valve, start-	
knocks, causes and remedies,		ing.....	383
table.....	410	four-valve, steam rates.....	328
laying up.....	388	operation profitable at low	
left-hand, illustration.....	21	pressures and high super-	
loading, electrical.....	353-357	heats.....	425
long-stroke, definition.....	32	SLIDE-VALVE automatic, illus-	
LOW-pressure, definition.....	36	tration.....	378
speed, definition.....	36	illustration.....	2
MECHANICAL efficiency, defini-		SINGLE-acting, definition.....	11
tion, formula.....	310	-VALVE, definition.....	32
losses, method of reducing....	300	test for valve leakage.....	389
mechanisms and nomenclature	19-38	sizes, selected to suit load curve.	438
MEDIUM-pressure, definition.....	36	SLIDE-VALVE condensing start-	
speed, definition.....	36	ing.....	380
modern, constructional, opera-		direction of rotation reversed.	140
ting and economic charac-		starting and stopping unaffec-	
teristics.....	319-340	ted by type of governor.....	378
MULTI-expansion, see also <i>Multi-</i>		SPEED for direct-connected	
<i>expansion engine</i> .		generator drive.....	436
valve, definition.....	32	methods of adjustment by	
new, valve setting.....	112	governors, illustrations.....	215
NON-CONDENSING, definition.....	36	splash-oiled, illustration.....	465
SLIDE-VALVE, starting.....	378	STEAM, see also <i>Steam engine</i> .	
stopping.....	380	function.....	1
non-releasing Corliss-valve,		modern types.....	319-340
starting and stopping.....	380	superheated steam used in. 417-426	
old, valve setting.....	113	taking steam for full stroke,	
operating costs.....	432	illustration.....	10
OPERATION conforming to load		TANDEM-COMPOUND, illustration.	24
curve, graph.....	438	slide-valve, starting.....	387
on superheated steam.....	422	TESTS, data and results, Ameri-	
oscillating-cylinder, illustration.	35	can Society of Mechanical	
out of line, effect on bearings....	405	Engineers.....	369-371
overhauling.....	388	data necessary, table.....	343
PERFORMANCE and maintenance,		duration.....	365
daily record.....	414	results corrected to standard	
Rankine cycle used as stand-		conditions.....	443
ard in engine testing.....	304	TESTING.....	342-372
records, purpose of keeping....	415	clearance volume determined	
plan lay-out.....	406	in.....	366
portable slide-valve, uses.....	323	equipment.....	344
proper management purposes....	373	for mechanical efficiency....	359
quadruple-expansion vertical, il-		procedure.....	343, 358
lustration.....	25	thermal efficiency computation.	364
RECIPROCATING, see also <i>Recipro-</i>		throttling-governed direct-valve,	
<i>cating engine</i> .		setting valve for selected	
management, operation and		equal leads example.....	122
repair.....	373-415	total annual cost.....	427, 433

	PAGE		PAGE
ENGINE, total, steam used per hour.....	81	Feeler, heating of inaccessible bearings detected by, illustration	379
TRIPLE-compound, definition.....	25	Fessenden, C. H., "Valve Gears".....	84
expansion, illustration.....	25	FILTER, OIL, illustration from "Southern Engineer".....	474
twin-cylinder, illustration.....	23	improvised.....	476
types, classification.....	19	operation.....	474
UNIFLOW, construction and operation.....	331	"Power," illustration.....	475
definition.....	33	precipitation compartment, illustration.....	477
poppet valve, starting.....	385	Richardson-Phenix Company, illustration.....	476
UNIT ENERGY COST, COMPUTATION, formula.....	427	Filtering and circulation oil system, illustration.....	468
example.....	434	"Financial Engineering," O. B. Goldman, steam consumption of condensing and non-condensing engines.....	286
unit, typical, illustration.....	322	Fire-point of oil.....	454
VALVES for use with highly superheated steam.....	419	FITCHBURG ENGINE, direct of rotation changed.....	255
maximum pressures and superheats, table.....	421	valve mechanism, illustration..	325
methods of control by shaft governor.....	239	FITCHBURG governor, illustration and operation.....	254
VARIABLE-cut-off, definition.....	37	Fixed-cut-off engine, definition.....	36
speed, definition.....	216	Flash-point of an oil, definition.....	454
vertical, illustration.....	20	FLEMING-HARRISBURG engine governor, adjustments.....	249
warming facilitated by by-pass to both ends of cylinder.....	379	four-valve engine, valve-setting directions.....	175-178
WATER RATE calculation, based on indicated horse power, formula.....	363	FLY-BALL GOVERNOR, adjustable thrust bearing, illustration.....	225
determination by steam condenser.....	357	adjustments and their effects, table.....	221
weight of steam used computed from indicator diagram.....	80	definition.....	38, 193
ERIE BALL ENGINE COMPANY, directions for setting Ball Corliss engine valves.....	173	methods for controlling steam... neutral or isochronous, definition.....	195
piston valve engine, illustration.....	420	principles and adjustment... 192-227	227
simple balanced-slide-valve engine, illustration.....	321	speed variation permitted by... 195	195
Sweet valve, illustration.....	90	stable or static, definition.....	204
ERIE CITY IRON WORKS, single-cylinder Lentz engine, illustration.....	326	unstable or astatic, definition... 204	204
valve setting directions for Lentz poppet-valve engine... 188-190	188-190	weight- or spring-loaded.....	207
Erie Engine Works, simple slide-valve automatic engine, illustration.....	378	FLYWHEEL, direction of rotation.....	22
ERIE governor, Jarecki Manufacturing Company, table of sizes.....	224	inspection.....	374
pump governor, illustration.....	197	method of balancing, illustration	236
EXHAUST line, purpose.....	67	shaft governor, balance.....	235
pressure, effect on compression, graph.....	69	Foaming boiler danger with superheated steam.....	425
EXPANSION curve, ideal compound engine.....	272	FORCE-FEED CIRCULATION SYSTEM, advantages and disadvantages.....	471
free, compound engine, definition.....	271	external-bearing lubrication... 469	469
larger cylinder necessary for given work output.....	13	table of oils used.....	459
LINE, leaky valves revealed by... 66	66	FORCE-FEED lubricator, see also Lubricator, force-feed.....	484
STEAM, form of curve.....	16	pump, illustration.....	484
engine.....	65	Foster superheater catalogue effect of superheat, graph.....	423
theoretical, graph.....	66	FOUR-VALVE ENGINE, construction and use.....	324
RATIO OF, definition.....	260	low steam rate.....	327
work to heat increased by.....	13	FOXBORO MANUFACTURING COMPANY, continuous revolution counter, illustration.....	345
steam, work done.....	12	hand tachometer, illustration... 346	346
total ratio, compound engine, definition.....	271	FRICTION, definition.....	448
EXTERNAL BEARING, definition.....	460	fluid, definition.....	447
lubrication, see Lubrication, external bearing.....	460	horse power, definition.....	77, 342
External slide valve.....	87	SLIDING, definition.....	448
"Extra Hecla" cylinder oil for use with superheated steam....	422	when replaced by fluid friction	449
		rolling, definition.....	447
F		FULTON IRON WORKS COMPANY, St. Louis, cross-compound engine, illustration.....	268
Feed-water and steam cycle in power plant, illustration.....	306	Corliss engine, illustration.....	165
		live-steam reheater and receiver, illustration.....	269

	PAGE		PAGE
FULTON IRON WORKS COMPANY, receiver-pressure regulation device, illustration.....	277	GOVERNOR, hunting, definition of term in balance, explanation.....	210 235
Fulton-Corliss cross-compound engine, assembly drawing.....	329	incorrect application or poor condition, danger.....	222
G			
Gappot definition and purpose.....	211	lagging during changes in load, causes.....	223
Gardner throttling governor, spring arrangement, illustration...	209	LEVERS, adjustable, illustration..	219
"Gargoyle" cylinder oil for use with superheated steam.....	422	method of securing.....	201
Gear adjustment on governors.....	278	load indicator for.....	223
Gears, Corliss releasing, troubles of dash-pots.....	412	McIntosh and Seymour, illustration.....	253
GEHARDT "STEAM POWER PLANT ENGINEERING," frictional losses of engines.....	301	MECHANISM, binding, dangers due to.....	201
steam engine efficiencies and performance tables... 311-317		construction.....	201
GENERATOR, direct-current, determination of electrical output..	354	performance, terms used to describe.....	203
efficiency.....	355	Porter, relation between speed, height and weights of balls and counterpoise, formula..	208
electric, for engine loading.....	353	position for starting engine....	385
horse power input determination, formula.....	355	pulley, requirements and methods of securing.....	201
loading by water rheostat.....	357	Rites type, Troy vertical engine, illustration.....	247
power output, formula.....	354	Robb-Armstrong-Sweet type, illustration.....	248
Gland friction in engines.....	301	safety and reliability devices....	198
Goldman, O. B. "Financial Engineering," steam consumption of condensing and non-condensing engines.....	286	sensitiveness changing with speed changes.....	216
Governing high-pressure cylinder only, effect on receiver pressure.....	279	SHAFT, see also <i>Shaft governor</i> . full-load running position, how found.....	141
GOVERNOR, see also <i>Shaft governor and fly-ball governor</i> . ADJUSTMENT for different speeds by adding or removing weight.....	213	principles and adjustments... 228-257	
for promptness and speed regulation.....	219	SIMPLE PENDULUM, angular speed and ball height.....	205
to change engine speed.....	212	ball height, formula.....	206
American-Ball engine.....	250	spring- or weight-loaded, advantages over simple pendulum	207
attentions required.....	225	steam-engine, classification....	37
BELT, requirements.....	201	THROTTLING, selection.....	224
oily or slack, danger.....	201	table of sizes.....	224
Buckeye, illustration.....	251	typical shaft, illustration.....	37
centrifugal force.....	204	unstable, useless for engineering purposes.....	204
classification.....	193	vibration, causes.....	223
Corliss engine, illustration.....	192	weight, revolving, centrifugal force developed formula....	205
dash-pot size varying with load conditions.....	211	wheel, Troy automatic engine, method of balancing, illustration.....	236
definition.....	192	when necessary.....	193
effect on slide-valve setting.....	140	rod pivots, proper end-play, illustration.....	202
enclosed spring, illustration.....	202	"Governors and the Governing of Prime Movers," W. Trinks, on racing.....	222
engine, functions.....	37	Graphite, flake, use in valve and cylinder lubrication.....	479
Erie pump, illustration.....	197	GRAVITY-CIRCULATION SYSTEM, advantages.....	470
failure, engine and power plant wrecks due to.....	198	external-bearing lubrication... 467	
Fitchburg type, setting.....	254	GRAVITY oiling system, four-window sight-feed oiler, illustration..	468
Fleming-Harrisburg centrifugal inertia, illustration.....	250	TRIP GEAR, "Hamilton" Corliss engine, illustration.....	155
FLY-BALL, see also <i>Fly-ball governor</i>	192-227	Murray Corliss engine, illustration.....	157
definition.....	193	valve, MacCord Manufacturing Company, illustration.....	479
illustration.....	38	GRIDIRON VALVE, definition.....	28
principles and adjustment	192-227	engine, features.....	91
flywheel in balance, explanation.	235	Grossenbacher, E., oil filter, illustration.....	475
forces for detecting engine speed variations.....	194	H	
GEAR adjustment.....	278	HAMILTON Corliss engine, gravity trip gear, illustration.....	155
example of changing.....	217		
"Hamilton" uniflow poppet-valve engine, illustration...	255		
horizontal tension spring, illustration.....	194		

	PAGE		PAGE
INDICATOR PENCIL, method of adjusting.....	56	LENTZ ENGINE, high-pressure steam-valve gear, illustration.....	189
requirements.....	58	poppet-valve, valve setting directions.....	188-190
piping for.....	50	report on record steam rate for uniflow engine.....	332
practice.....	40-83	single-cylinder, illustration.....	326
REDUCING, adjustable pantograph for, illustration.....	47	LEVER, governor, method of securing.....	201
MECHANISM, classification.....	44	pencil mechanism, Thompson indicator, illustration.....	44
when necessary.....	43	Life of engine, effect on selection of engine.....	437
motion, tests before using.....	49	Lineal clearance, definition.....	3
single, for cylinder, disadvantages.....	51	LOAD curve, power plant, for engine selection.....	437
SPRING, adjustment.....	56	ELECTRICAL, determination with three-phase alternating-current generator.....	356
card illustrating test.....	54	of engine.....	353-357
classification.....	52	factor of power plant, definition.....	438
for engine, selection.....	55	indicator for engine governors, illustration.....	223
periodic tests necessary.....	53	-measuring apparatus, classification.....	346
safe pressures, table.....	53	-output determination, direct-current generator, illustration.....	354
scale, formula.....	54	Locomobile steam engine unit.....	333
test.....	53	Long-stroke engine, definition.....	32
two, operated from one reducing mechanism, illustration.....	57	Losses, steam-engine, classification.....	293
use in valve-setting operations.....	142	Loss, mechanical.....	8
valve setting defects determined by.....	143-144	Low-pressure engine, definition.....	36
Watt's, illustration.....	41	-speed engine, definition.....	36
INDIRECT measurement method of ascertaining valve operation.....	108	LUBRICANTS, classification.....	450
slide valve.....	87	semi-solid, uses.....	451
INERTIA, principle of, applied to revolving governing parts.....	231	solid, use.....	450
shaft governor operation.....	229	LUBRICATION, automatic, for external bearings, merits.....	470
temporary control in shaft governor effected by.....	231	chart, steam cylinders and valves.....	457
Inside-admission slide valve.....	87	DROP-FEED, applications suitable for steam engines.....	462
Instruments, inspection.....	376	of external bearings.....	461
Insulation, thermal losses reduced by.....	299	engine.....	447-487
Interheater, definition.....	269	EXTERNAL BEARINGS, by hand.....	460
INTERNAL bearings, definition.....	460	force-feed circulation system.....	469
lubrication, see also <i>Lubrication, internal</i>	478-486	gravity-circulation system.....	467
slide valve.....	87	splash system.....	465
J		force-feed, compound marine engine with, illustration.....	470
Jarecki Manufacturing Company, throttling governor sizes, table.....	224	INTERNAL-bearing.....	478-486
Jig, for boring babbitted bearing boxes.....	398	of engines, automizer for, illustration.....	479
Journal and bearing, clearance between.....	402	purpose.....	447
K		stuffing boxes.....	480
Kahl, J. C. oil filter, illustration.....	474	SYSTEM, choice of oil affected by.....	456
KNOCK, apparent location deceptive causes and remedies.....	410	for external bearings, classification.....	460
location ascertained by sounding rod.....	412	steam engines, classification.....	460
L		"Lubrication, Practice of," T. C. Thomsen, selection of oils for engine lubrication, tables.....	456-460
LAP angle, definition, illustration.....	100	LUBRICATOR, FORCE-FEED, illustration.....	484
steam and exhaust, purposes.....	95	installation.....	485
valve, definition.....	94	LUBRICATOR, HYDROSTATIC, care and operation.....	482
Lapping plate.....	392	leakages of joints or packing.....	483
LEAD angle, definition, illustration.....	100	prevention of trouble.....	483
explanation of term.....	96	principle.....	480
measurement, illustration.....	124	water feed valve.....	483
proper for slide valve.....	115	LUBRICATOR, independent or central, starting.....	378
LEADS, EQUAL, designed-determined definition.....	114	mechanical force-feed.....	483
selected, definition.....	114	Meyeringh proportional, illustration.....	486
Leads, laps and trial compressions, Corliss-valve engine, table.....	169	multiple-feed mechanical.....	485
Leakage loss, less in compound than in simple engine, explanation.....	264	proportional, definition.....	485
Left-hand engine, definition.....	21		

	PAGE		PAGE
LUNKENHEIMER COMPANY, auxiliary graphite feeder, illustration.	480	MULTI-EXPANSION ENGINE	258-282
drop-feed oil cup, illustration.	462	advantages and disadvantages.	260
Lever-handle oil pump, illustration.	480	application.	258
		best receiver pressure, how found.	276
		saturated steam operation economics, table.	314-315
Mc		stopping.	387
McINTOSH AND SEYMOUR four-valve engine.	324	MULTI-PORTED slide valve, advantages and disadvantages.	90
governor.	253	VALVE, definition.	27
gridiron valve, illustration.	28	setting.	131
engine, valve construction.	93	Multi-valve engine, definition.	32
valve-operating mechanism, illustration.	92	MURRAY IRON WORKS, Burlington Iowa, Corliss-valve dash pot, illustration.	159
		governor adjusted by weight, illustration.	213
M		gravity trip gear illustration.	157
MacCord Manufacturing Company, gravity valve, illustration.	479		
MAIN BEARING box, pouring.	397	N	
boxes, babbitted while warm.	397	"National Engineer," T. G. Thurston, gravity-circulation system, illustration.	469
correct oil grooves.	399	Newton, Sir Isaac, principle of inertia.	231
heating.	403	Ninde, W. E., "Design and Construction of Heat Engines," on valve diagrams.	84
method of gaging wear.	410	NON-CONDENSING ENGINE, see also <i>Engine, non-condensing</i> .	
normal wear, effect on shaft.	409	auxiliary piping and equipment, illustration.	375
quartered, dismantling for re-babbitting.	396	definition.	36
Main-valve operating mechanism, McIntosh and Seymour engine, illustration.	93	Non-condensing operation.	283-290
Mandrel, use in babbitting main bearings.	397	Non-releasing Corliss-valve engine, starting and stopping.	380
Marker, stationary, method of placing engine on dead center.	105	NORDBERG engine, positively-operated poppet admission valve, illustration.	31
MARKS "MECHANICAL ENGINEERS' HANDBOOK," clearance values, table.	297	engine, variation in steam consumption.	294
Rankine cycle rates, table.	309	governor, spring-connected dash-pot rod.	212
Marine engine, four-cylinder triple-expansion, illustration.	280	long-range valve gear and governor.	156
MEAN EFFECTIVE PRESSURE.	12	standard Corliss valve gear, illustration.	159
formula for computing.	15	Nordberg Manufacturing Company, Corliss trip gear, illustration.	156
Mean indicator diagram, when necessary.	274	Nugent crank-pin oiler, illustration.	471
Measuring rod, head.	126		
MECHANICAL EFFICIENCY of engine, definition, formula.	310	O	
TEST apparatus, for simple engine.	360	Obliquity, connecting rod, definition and effects.	101
data sheet.	360	OIL barrels, methods of handling.	452
purpose.	342	chill point, definition.	455
"MECHANICAL ENGINEERS' HANDBOOK," clearance values, table.	297	choice affected by type of lubricating system.	456
Rankine cycle rates, table.	309	circulation, table of properties.	456
"MECHANICAL EQUIPMENT OF BUILDINGS," HARDING AND WIL-LARD, Corliss engine governor, illustration.	192	classification.	451
regulation guarantee tests.	204	collecting devices, illustration.	472
MECHANICAL LOSSES, definition.	8, 294	compounded, definition.	451
methods of reducing.	300	CYLINDER, engines using super-heated steam.	421
Mechanical work, small part of total heat converted into by engine.	291	table of grades.	458
Mechanisms, engine.	19-38	table of properties.	458
MEDIUM-pressure engine, definition.	36	deposit-forming.	456
-speed engine, definition.	36	filtering outfit, S. F. Bowser and Company, Incorporated.	478
Meyeringh proportional lubricator, illustration.	486	FILTER, see also <i>Filter, oil</i> .	
Meyer riding-cut-off valve, illustration.	28, 134	filtering materials used.	474
Model Acme engine, trunk piston mechanism, illustration.	35	fire-point, definition.	454
Monel metal, for valves used with superheated steam.	421	fixed, definition.	451
		flash-point, definition.	454

	PAGE		PAGE
OIL, force-feed circulation systems, table.....	459	Pickering and Gardner governor catalogues, selection of throttling governor.....	224
groove, cutting, illustration....	400	PICKERING GOVERNOR, methods of adjustment, illustration....	216
high-speed splash-oiled engines, table.....	460	safety idler feature, illustration.....	198
methods of supplying to moving bearings.....	471	Pipe, velocity of fluid in.....	449
mineral, definition.....	451	PIPING, engine, inspection.....	376
PURIFIER, operation.....	474	indicator, see <i>Indicator piping</i> ...	51
capacities.....	476	steam, simple engine, illustration	377
selection, requirements to be met	455	PISTON, clearance, definition.....	3
specific gravity, how found.....	453	leakage, rejection losses caused by.....	296
steam-engine lubrication, selection, tables.....	456	low-friction, illustration.....	302
swing joints for supplying crank and crosshead pins, illustration.....	473	RING, cast-iron snap, replacement.....	389
system, filtering and circulation type, illustration.....	468	expanding by peening.....	393
tests for properties.....	452	fitting.....	390
viscosity, measurement.....	453	repairing, illustrations.....	391
Oil Well Supply Company, Pittsburgh, Meyering proportional lubricator, illustration.....	486	replacement.....	389
OILER, bottle type.....	463	solid, cutting.....	392
crank-pin, illustration.....	463	tested for fit.....	393
crosshead-pin telescopic, illustration.....	472	worn, expanded by peening...	393
drop-feed.....	461	SLIDE VALVE, advantages and disadvantages.....	88
Oiling, hand.....	461	definition.....	27
Operating-condition test, purpose....	342	desirable in vertical engines.....	27
Ordinates, method of, for finding mean effective pressure, graph....	71	inside admission type.....	88
Oscillating-cylinder engine, definition	35	repair.....	394
Output, electrical, direct-current generator.....	354	setting for selected lead, illustration.....	121
Outside-admission slide valve.....	87	-rod nuts, methods of locking, illustration.....	374
Over-all efficiency based on brake horse power, formula.....	310	PLANIMETER, Amsler polar, operation averaging, definition.....	73
P			
PACKING, metallic, used with high-pressure superheated steam.....	422	Coffin, operation.....	75
rings.....	392	mean effective pressure found by polar, adjustable tracer arm.....	74
sheet, for valve-chest covers and flanged joints.....	404	Willis.....	76
soft, replacement.....	405	Polar planimeter, adjustable arm, diagram.....	74
steam engine.....	403	POPPET VALVE.....	146-191
stuffing box, correct and incorrect arrangement, illustration.....	405	advantages and disadvantages	159
PANTOGRAPH as an indicator reducing mechanism.....	46	Ames Unaflo engine, directions for setting.....	182-186
engine fitted with, illustration....	47	definition.....	31
Paper, indicator, requirements and placement on drum.....	57	detaching or releasing, definition.....	31
Parallel-link pencil mechanism.....	43	ENGINE efficiency increased by method of governing.....	146
PEENING in main bearing-box.....	398	starting.....	385
snap packing ring.....	393	location in engine cylinder....	160
PENCIL, indicator, requirements....	58	mechanism, typical designs.....	161
MECHANISM, indicator, advantages.....	42	operating mechanism, Vilter engine, illustration.....	162
types.....	43	positively-operated, definition..	31
PENDULUM, angular speed and ball height.....	205	reason for employing.....	146
LEVER, inverted, with Brumbo pulley, illustration.....	45	repair.....	395
reducing mechanism, construction.....	44-46	single- and double-beat, definition.....	160
SIMPLE, ball height, formula.....	206	Portable slide-valve engine, uses....	323
or Watt's governor, illustration.....	193	Porter governor, relation between speed, height and weights of balls and counterpoise, formula.....	208
Performance specifications, Corliss engines.....	441-442	Porter-Allen engine, variable-cut-off valve-mechanism, illustration.....	36
Peterson oil filter, operation.....	476	POSITIVELY-OPERATED CORLISS and poppet valves, setting.....	173
		valve mechanisms.....	149
		POWER, definition.....	14
		HORSE POWER, see also <i>Horse power</i> .	
		increase due to condensing operation, methods of calculating.....	285

	PAGE		PAGE
POWER, output, generator, formula..	354	RACING, definition.....	222
PLANT, daily load curve.....	437	engine with shaft governor,	243
drawing from "Power".....	iv	causes.....	243
efficiency based on use of		RANKINE CYCLE ratios, different type	309
rejected heat.....	9	engines, table.....	309
inspection.....	373-377	ratio, definition, formula.....	309
load factor, definition.....	438	standard of engine perform-	304
regular inspection trips advis-		ance in steam-engine testing	307
able.....	387	RANKINE ideal cycle.....	7
steam engine, formulas for com-		water rate, formula.....	307
puting.....	14	Reach-rod, Corliss engine, illustra-	383
stroke, heat engine, definition..	11	Re-babbiting, necessary where bear-	395
"POWER," energy balance in electric-		ings are partially melted out	276
energy distribution circuits..	300	definition.....	267
hydrostatic lubricator, filled by		RECEIVER PRESSURE, best, receiver-	276
hand oil pump, illustration..	482	compound engine, dependent on	278
oil filter, illustration.....	475	cylinder ratio.....	276
power plant drawing from.....	iv	correct, necessary for economi-	277
savings effected by superheating		cal operation of compound	277
supply steam, table.....	423	engines.....	276
sight feed for drop-feed oiler,		regulation device, illustration..	276
illustration.....	464	variation during stroke.....	269
valve leakage test, single-valve		Receiver volume.....	415
engines.....	389	Reciprocating engine manage-	49
valve setting without removing		operation and repair.....	50
chest cover.....	132	REDUCING MECHANISM, inclined-plane	57
W. H. Wakeman on engine		type, illustration.....	48
safety devices.....	200	test for accuracy of reduction,	57
"Power House," hydrostatic lubrica-		illustration.....	57
tor, illustration.....	481	two indicators operated from,	43
PRESSURE and superheats, maximum		illustration.....	45
for engine valves, table.....	421	REDUCING MOTION, see also <i>Indicator</i>	48
and vacuum gages for engine		<i>reducing motion</i> .	48
testing.....	344	indicator.....	48
approximate mean effective,		pendulum-level, illustration....	48
formula for computing.....	15	REDUCING WHEEL, construction....	48
average or mean effective.....	12	principle, illustration.....	48
BACK, definition.....	10	Regulation guarantee tests for gov-	204
purpose of reducing with		ernor.....	269
condenser.....	285	Reheater, definition.....	6
boiler, see <i>Boiler pressure</i> .		Rejected heat in steam engine.....	297
effective, on piston.....	11	REJECTION LOSSES, cylinder con-	293
indicator springs, table.....	53	densation partly responsible	297
loss indicated by steam line.....	62	for.....	297
MEAN EFFECTIVE, found by		definition.....	294
method of ordinates.....	70	exhaust steam used for heat-	67
in cases of over-expansion....	72	ing.....	30
indirect methods of finding...	77	methods of decreasing.....	152
planimeter for finding.....	73	Release line, purpose.....	11
net, on piston, definition.....	10	RELEASING CORLISS-VALVE MECHAN-	140
range of engine, definition.....	258	ISM, definition.....	345
receiver, see <i>Receiver pressure</i> .		illustration.....	344
steam, work done by.....	9	Releasing mechanism, operation....	344
PRONY-BRAKE absorption dynamo-		Return stroke, definition.....	155
meter, construction.....	347	Reversing rocker, reversing rotational	357
cooling.....	347	direction of engine.....	345
illustration.....	347	REVOLUTION COUNTER, continuous..	344
lubrication.....	348	definition.....	344
portable, for testing small		hand.....	344
engines, illustration.....	348	Rheostat, water, generator loading	357
Providence Engineering Corporation,		accomplished by.....	357
jacketed engine cylinder,		Rice and Sargent Corliss engine,	295
illustration.....	295	jacketed cylinder, illustra-	329
Pulley, governor, method of secur-		ing.....	329
ing.....	201	Rice-Stix Dry Goods Company plant,	472
Pumps, inspection.....	375	engine indicator diagram..	476
		RICHARDSON-PHENIX COMPANY,	468
Q		crosshead-pin telescopic	472
QUADRUPLE-EXPANSION ENGINE, com-		oiler, illustration.....	476
bined indicator diagrams....	281	oil filter, illustration.....	468
definition.....	26	sight-feed oiler for gravity sys-	468
seldom used in stationary		tem, illustration.....	468
power plants.....	280		
Quartered main bearing illustration..	396		
R			
RACING, causes.....	222		

	PAGE		PAGE
RIDGWAY automatic engine, Rites governor, illustration.....	247	Selected equal leads, definition.....	114
FOUR-VALVE ENGINE, valve setting directions.....	178	SETTING, dimensions for, Ridgway simple four-valve engine, table.....	179
valve-operating mechanism, illustration.....	148	plain slide valves for equal leads, table showing procedure 116-	118
SIMPLE and cross-compound four-valve engines, results of adjustments, table.....	179	slide valve, first consideration... 113	
four-valve engine, table of dimensions for setting.....	179	steam-engine valves.....	107
tandem compound four-valve engine, results of adjustments, table.....	181	SHAFT governed engine, eccentric shifting inadvisable.....	115
Ridgway Engine Company, recommendation for valve setting for unequal leads.....	130	governing, forces required.....	229
RIDING-CUT-OFF VALVE, advantages and disadvantages.....	91	GOVERNOR, adjustment.....	245
definition.....	27	balance.....	235
engines with, uses.....	324	care of.....	245
mechanism, setting, explanation.....	133	classification.....	236
Right-hand engine, definition.....	21	classification table.....	240
RING-oiled bearing illustration.....	465	crank pin used in place of eccentric.....	239
packing, soft, illustration.....	404	definition.....	37, 228
snap, piston, repairing, illustrations.....	391	full-load running position, illustration.....	141
RITES GOVERNOR, dash-pot or drag springs for limiting rate of movement.....	246	hammering, remedy.....	246
illustration.....	232	methods of adjustment.....	229
ridgway automatic engine, illustration.....	247	method of controlling engine speed.....	233
special adjustments.....	248	methods of controlling engine valves.....	239
ROBB-ARMSTRONG SWEET GOVERNOR, adjustment.....	249	more economical than throttling governor.....	228
description.....	248	OPERATION, effects of weight and spring adjustment... 241	
Robertson, James L. and Sons, Willis planimeter, illustration.....	75	forces of two kinds employed.....	229
Rod area, effect in computing work done.....	13	troubles and remedies... 243-245	
ROPE BRAKE absorption dynamometer.....	350	permanent control, effected by centrifugal force.....	230
illustration.....	351	position fixed.....	256
ROTARY STEAM ENGINE, construction and disadvantages.....	319	principal adjustments, table.. 242	
illustration of principle.....	320	PRINCIPLES and terms same as those for fly-ball governor and adjustments... 228-257	
operation.....	320	results of combining centrifugal force and inertia.....	232
ROTATION, slide-valve engine, reversing direction of.....	140	simple weight employed, illustration.....	238
method, tare-weight of brake found by.....	349	sluggishness, causes.....	243
		speed regulation and governing action.....	233
S		temporary control effected by inertia.....	231
St. Louis Iron and Machine Works, piston construction in St. Louis Corliss engine, illustration.....	374	type of engine used on.....	228
SAFETY idlers, belt-driven governors. 198		use of both centrifugal force and inertia, explanation... 233	
knock-off cams, Corliss governors.....	198	variable cut-off governor.....	228
stop, engine governor provided with.....	198	"Shaft Governors," Hubert E. Collins on shaft governor operation.....	239
Saturated steam and superheated steam, differences.....	418	Sherwood Manufacturing Company, oil collecting devices, illustration.....	472
Saybolt viscosimeter, illustration... 454		Shims, bearings adjusted by means of.....	400
Schaeffer and Budenburg Manufacturing Company fixed tachometer, illustration.....	346	Short-stroke engine, definition.....	32
Schutte and Koerting Company, catalogue, Corliss engine with condenser, illustration. 284		Side-crank engine, definition.....	20
Scotch-yoke mechanism velocity diagram.....	102	Sight-feed oiler, four window, gravity oiling system, illustration... 468	
		SIMPLE balanced-slide-valve engine, illustration.....	321
		D-slide valve engine, illustration	23
		SINGLE-acting engine, definition.... 11	
		-beat poppet valve, definition... 160	
		-ECCENTRIC DETACHING CORLISS-VALVE engine, valve setting directions.....	163-169
		mechanism, features.....	154
		-VALVE ENGINE, definition.....	32
		simple, construction and operation.....	321-323

	PAGE		PAGE
SKINNER engine-governing mechanism, illustration.....	228	STARTING block, lever and wrist plate, Corliss engine.....	384
tandem-compound engine, governing of high-pressure cylinder, illustration.....	259	STEAM and feed-water cycle in power plant, illustration.....	306
"UNIVERSAL UNAFLOW" ENGINE, steam-consumption curves	331	chest diagram, value.....	64
valve-operating mechanisms, illustration.....	161	CONSUMPTION, CALCULATION from indicator diagram... 80	304
SLIDE VALVE, see also Valve, slide.	84-144	on dry-steam basis.....	304
balanced, illustration.....	89	condensing and non-condensing engines, table.....	286
condensing engine, starting.....	380	uniform engine, variation in... 294	304
definition.....	26	dry, weight of.....	304
displacement, definition.....	101	ENGINE, see also <i>Engine, steam</i> .	
engine, direction of rotation.....	140	approximate attendance costs, graph.....	439
function.....	84	condensing and non-condensing, stopping.....	382
INSIDE-admission, illustration... 87		condensing operation, definition.....	283
clearance, definition.....	95	conditions necessary for highest theoretical efficiency.... 6	
lap, how changed.....	96	costs of different types, table.. 340	
mechanism adjustment.....	111	depreciation rates.....	431
method of controlling steam flow.....	84	EFFICIENCIES and performance, tables..... 311-317	
motion received from eccentric.. 97		how increased..... 291-317	
multiported, advantages and disadvantages.....	90	mathematical methods of computing..... 302-317	
outside-admission, illustration.. 87		ways of expressing..... 303	
plain, setting for selected lead, illustration.....	123	efficient, definition..... 9	
proper lead.....	115	ELEMENTARY, construction... 2	
riding-cut-off, advantages and disadvantages.....	91	operation..... 3	
SETTING, defects determined by indicator..... 143-144		energy abstracted from steam.. 7	
effect of governors on..... 140		expansion line in..... 65	
first step..... 113		first cost, factors influencing.. 335	
FOR EQUAL cut-offs..... 129		fly-ball governors, principles and adjustment..... 192-227	
leads..... 115		function and principle..... 1-18	
without removing steam chest cover, explanation..... 132		GOVERNOR, see also <i>Governor, steam-engine</i> .	
three conditions to be set for.. 113		functions..... 37	
type of engine used in..... 84		heat converted into mechanical work..... 291	
Snap ring, fitting, illustration... 390		horizontal, definition..... 20	
Sounding rod, knocks located by... 412		inclined, definition..... 20	
"Southern Engineer Kink Book," engine alignment..... 408		ideal, illustration..... 7	
"SOUTHERN ENGINEER," oil filter, illustration..... 474		indicators..... 40-83	
riding-cut-off valve setting.. 134-140		LOSSES, classification..... 293	
SPEED, governor adjustments for changing..... 212		large part unavoidable..... 292	
method of control by shaft governor..... 233		LUBRICATION..... 447-487	
regulation, good shaft governor.. 233		selection of oils for, tables... 456-460	
VARIATION, fly-ball governor... 195		systems, classification..... 460	
governed and ungoverned engines, graph..... 193		mechanisms and nomenclature..... 19-38	
SPLASH oiling systems, advantages.. 470		MODERN, classification as to type, table..... 336-339	
-oiled engines, table of oils for.. 460		types..... 319-340	
system, external bearing lubrication..... 465		packings for..... 403	
SPRING adjustment, shaft-governor operation, effects..... 241		performance guarantees..... 440	
INDICATOR, see <i>Indicator springs</i> .		plant, heat-flow, explanation.. 1	
adjustment..... 56		power, formulas for computing 14	
classification..... 52		purposes of testing..... 342	
rules for selection..... 55		rejection losses, methods of decreasing..... 294	
safe pressures, table..... 53		rotary, construction and disadvantages..... 319	
testing apparatus, illustration.. 54		specifications for quotations.. 444	
-LOADED governor, advantages over simple pendulum governor..... 207		suitable applications for drop-feed lubrication..... 462	
governor, comparison with weight-loaded..... 209		TESTING, see also <i>Engine testing</i> 342-372	
STANDARD CRANK-MECHANISM, definition..... 34		data and results..... 369-371	
velocity diagram..... 102		ideal Rankine cycle standard of engine performance 304	
STARTING block, Corliss engine governor..... 385		TYPE using slide valves..... 84	
		classification table..... 19	
		VALVES, repair..... 393	

	PAGE		PAGE
STEAM ENGINE VALVE, setting.....	107	SUPERHEATED STEAM, effect in decreasing cylinder condensation and leakage, graph..	425
vertical, definition.....	20	gain resulting from use in engines.....	417
warmed and drained before starting.....	377	generation.....	418
water rate taken as measure of economy.....	308	metals for valves and seats used with.....	421
"Steam Engine Test Code," American Society of Mechanical Engineers, Outline.....	369-371	USE IN compound or triple-expansion engines.....	424
"STEAM ENGINE TROUBLES," H HAMKEN, enclosed-spring governor, illustration.....	202	engines.....	417-426
governors.....	193	valves for engines using.....	419
governor with horizontal tension spring, illustration.....	194	Superheater installation, typical, illustration.....	418
STEAM expansion line, form of curve.....	16	SUPERHEATING, effect on efficiency of simple engine, graph.....	295
EXPANSIVE USE, economy.....	12	supply steam, saving effected by, table.....	423
when not desirable.....	13	Supplies, engine, inspection.....	377
FLOW, controlled by slide valve.....	84-87	SWEET governor, operating gridiron valve, illustration.....	244
DIRECTION, INTO counterflow-engine cylinder, illustration.....	33	valve, Erie Ball Engine Company, illustration.....	90
uniflow-engine cylinder, illustration.....	33	Symbols list.....	xii
jacketing, method of decreasing rejection losses.....	296		
LINE, ideal.....	63	T	
pressure losses indicated by... variations, illustration.....	62 63	Tabor indicator, curved-slot parallel motion, illustration.....	44
methods for controlling used, with fly-ball governors.....	195	TACHOMETER, definition.....	345
port locations, marking for valve setting.....	127	fixed.....	346
"Steam Power," Hirshfeld and Ulbricht, engine classification.....	19	hand.....	346
"STEAM POWER PLANT ENGINEERING," frictional losses of engines.....	301	TANDEM-COMPOUND ENGINE combined diagrams.....	272
Gebhardt, steam engine efficiencies and performance, tables.....	311-317	definition.....	23
STEAM quality determination.....	362	governing of high pressure cylinder, illustration.....	259
rate, four-valve engines.....	327-329	starting.....	387
saturated and superheated, differences.....	418	surface condenser connected with, illustration.....	284
SUPERHEATED, see also <i>Superheated steam</i> .		typical high-speed, illustration..	323
use in engines.....	417-426	water rate determination, illustration.....	366
TOTAL, used per hour by engine..	81	Tare-weight of brake, definition.....	348
work.....	8	Telescopic tubes, eccentrics and crosshead pins oiled by.....	473
WEIGHT USED by engine with no clearance, formula.....	79	Temperature range of engine, definition.....	258
computation.....	78-81	TEMPLET, application in finding dead centers of eccentric.....	106
WORK DONE BY direct pressure..	9	arrangement on valve chest for valve setting, illustration..	128
expansion.....	12	method of ascertaining valve operation.....	109-111
work necessary to expell from cylinder.....	10	valve setting, for indirect-valve engine.....	126
Stone, A. O., hydrostatic lubricator, illustration.....	481	Terminal drop, compound engine, definition.....	271
STROKE, definition.....	11	"Test Code," American Society of Mechanical Engineers, water-rate test specifications	365
working, heat engine, definition.....	11	engine, see also <i>Engine testing</i>	342-372
Stuffing boxes, inspection.....	375	Test results facilitated by calculation of engine and brake constants.....	368
SUPERHEAT, effect of, B u c k e y e engines, graph.....	423	Theoretical water rate computation, based on ideal Rankine cycle formula.....	307
influence on water-rate, graph... and pressure, maximum for engine valves, table.....	423 421	THERMAL EFFICIENCY based on brake horse power, formula.....	310
SUPERHEATED STEAM, advantages and disadvantages, table.....	425	computation on basis of indicated horse power, formula.....	307
and saturated steam, differences.....	418	definition.....	303
cylinder oil for engines using... desirability of compounding partially obviated by.....	421 422	computation.....	364
economical in uniflow engines... ..	424	formula.....	305
		test, purpose.....	342

	PAGE		PAGE
THERMAL LOSS cylinder condensation partly responsible for.....	297		
definition.....	8, 293		
method of reducing.....	299		
Thompson indicator, illustration..	40, 42		
THOMSEN, T. C., lubrication chart for steam cylinders and valves.....	457		
"Practice of Lubrication," selection of oils for engine lubrication, tables.....	456-460		
Throttling governor, selection.....	224		
Thurston, T. G., Gravity-circulation system, illustration.....	469		
Tolle governor, general arrangement, illustration.....	209		
Tools, engine, inspection.....	377		
TORQUE, definition of term.....	260		
regularity increased in compound engines explanation.....	265		
variation graphs, tandem-compound engine.....	266		
Tram, illustration.....	104		
TRAMMEL, application in finding dead centers of eccentric.....	107		
gage, valve setting with.....	125		
method of placing engine on dead center.....	104		
Travel, valve, definition.....	98		
Trinks, W., "Governors and the Governing of Prime Movers" on racing.....	222		
TRIP GEAR, function.....	157		
operation.....	152		
Reynolds, for Corliss engines, illustration.....	152		
TRIPLE-compound engine, definition..	25		
EXPANSION ENGINE, definition..	25		
seldom used in stationary power plants.....	280		
use of superheated steam.....	424		
pumping, receiver and drain arrangement, illustration..	270		
TROY AUTOMATIC ENGINE directions for reversing.....	235		
method of balancing governor flywheel, illustration.....	236		
Troy Engine Company method for setting vertical engine on dead center.....	105		
Trunk-piston mechanism, definition..	35		
Twin-cylinder engine, definition.....	23		
U			
UNIFLOW ENGINE, construction and operation.....	331		
CYLINDER, connection to surface condenser, illustration	253		
direction of steam flow from, illustration.....	34		
lubrication.....	424		
definition.....	33		
four-valve, for non-condensing service.....	329		
manufacturer's guarantees.....	443		
most profitable degree of vacuum.....	289		
NON-CONDENSING, construction and operation.....	332		
economy.....	333		
starting.....	385		
superheated steam economical	424		
"Universal una-flow" engine, valve-operating mechanism, illustration.....	161		
		V	
VACUUM, actual and theoretical difference.....	382		
most profitable degree in uniflow engine.....	289		
Oil Company, cylinder oil for use with superheated steam..	422		
VALVE adjustments, importance of dead centers.....	103		
arms, steam and exhaust, Harrisburg four-valve engine, table showing advance.....	178		
automatic by-pass, Ames uniflow engine, illustration.....	185		
balanced slide, advantages and disadvantages.....	89		
CHEST, templates arranged on... vertical-engine, measurement for valve setting.....	127		
Corliss, see also <i>Corliss valves</i> ..	146-191		
D-SLIDE, advantages and disadvantages.....	87		
illustration.....	26		
detaching-poppet admission, "Hamilton" engine, illustration.....	32		
diagrams, definition.....	84		
double-ported Corliss, illustration.....	29		
ellipse, definition.....	84		
ENGINE, repair.....	393		
using highly superheated steam.....	419		
friction in engines.....	301		
GEAR ADJUSTMENTS, Ames uniflow engines, table showing effects.....	187		
effects on detaching Corliss-valve engines, table....	170-171		
Allis-Chalmers heavy duty Corliss engine, illustration..	158		
Ames four-valve non-releasing Corliss engine, illustration..	150		
"Valve Gears," C. H. Tessenden, on valve diagrams.....	84		
VALVE, governor-operated cut-off... gridiron, illustration.....	28		
HAND-adjustable cut-off.....	28		
-operated, engine with, illustration.....	4		
inspection.....	374		
LAP, definition.....	94		
effects of changing, table.....	96		
LEAKAGE, rejection losses caused by.....	296		
revealed by expansion line... single valve engine, test for... maximum pressures and superheats for different types, table.....	389		
MECHANISM, releasing or detaching, definition.....	30		
variable-cut-off, engine equipped with, illustration.....	36		
Meyer riding-cut-off, illustration.....	28		
multiported slide, illustration..	27		
operating mechanism, McIntosh and Seymour engine, illustration.....	92		
OPERATION, indirect-measurement method of ascertaining.....	108		
Ridgway four-valve engine, illustration.....	148		
PISTON SLIDE, advantages and disadvantages.....	88		

	PAGE		PAGE
VALVE, PISTON SLIDE comparison to D-valve.....	27	WATER BRAKE, horse power absorbed by.....	352
POPPET, see also <i>Poppet valves</i> 146-191	146-191	definition and operation.....	352
single-seated admission, illustration.....	31	principle, illustration.....	352
positively-operated poppet admission, illustration.....	31	WATER in cylinder, knocks caused by	410
SETTING, Ball Corliss engines.....	173	RATE, approximate calculation by means of indicator cards.....	364
Chuse condensing uniflow engine.....	188	calculation on basis of indicated horse power, formula.....	363
compound engine.....	280	determination by boiler-feed method.....	361
Corliss and Poppet valves.....	146-191	STEAM ENGINE, determination by steam condenser.....	357
defects, remedies.....	143-144	measure of economy.....	308
double-eccentric detaching Corliss-valve engines.....	172	tandem-compound engine, equipment for determining.....	366
"Fleming-Harrisburg" four-valve engine.....	175-178	TEST, apparatus, illustration..	358
Lentz poppet-valve engines.....	188-190	data sheet.....	362
measuring rod for.....	126	purpose.....	342
methods of.....	107	simple engine.....	360
new engine.....	112	wet steam weight expressed in terms of dry steam weight.....	336
old engine.....	113	A m e r i c a n Society of Mechanical Engineers' specifications.....	365
operations, indicator used.....	142	theoretical, computation based on ideal Rankine cycle, formula.....	307
Ridgway four-valve engine.....	178	rheostat, explanation, illustration.....	357
selected equal leads, example, illustrations.....	119	Watt, James, inventor of governor... 193	193
shaft-governed engine.....	114	Wattmeter, direct-current, load-output of generator determined with.....	355
single-eccentric detaching-Corliss-valve engine.....	163-169	WATT'S governor, illustration.....	193
templets used for.....	129	high-speed loaded governor, general arrangement, illustration.....	214
unequal leads.....	130	indicator, operation.....	41
Vilter poppet-valve engine... 190	190	Wear, definition.....	447
with trammel gage.....	125	WEIGHT adjustment, shaft-governor operation, effects.....	241
without removing chest covers, example.....	125	-LOADED GOVERNOR, advantages over simple pendulum governor.....	207
simple automatic, engine with, illustration.....	4	comparison with spring-loaded.....	209
single-ported Corliss, illustration	28	Weiss, W. R., hydrostatic lubricator filled by hand oil pump, illustration.....	482
SLIDE, see also <i>Slide valve</i>	84-144	Wheel, reducing, use of.....	48
flat type.....	26	Wiley, John and Sons, engine performance tables.....	311-317
piston type.....	26	Willis planimeter, illustration.....	75
stem adjustment, illustration... 111	111	WIPER CUP, eccentrics and crosshead pins oiled by.....	473
TEMPLET, laying off.....	127	method of using in oiling crosshead pin, illustration.....	472
length.....	128	WOOLF-compound engine, definition, illustration.....	267
TRAVEL with eccentric motion, illustration.....	98	-tandem compound engine, temperatures in various parts, illustration.....	263
relation to eccentricity.....	99	WORK, net, steam upon piston.....	11
VARIABLE-cut-off engine, definition.. 37	37	per double stroke by any engine, formula.....	13
speed engine, definition.....	216	total, done by steam.....	8
Velocity diagram, standard crank and scotch-yoke mechanisms.....	102	Wrist-pin bearing, heating.....	403
Vertical steam engine, definition.....	20		
VILTER MANUFACTURING COMPANY, Corliss-valve trip gear, illustration.....	156		
poppet-valve engine, illustration.....	160		
Tolle governor, illustration.....	209		
Watt governor number two, illustration.....	214		
Vilter poppet-valve engine, valve setting directions.....	190		
Viscosimeter, illustration.....	454		
VISCOSITY OF liquid, definition.. 450	450		
oil, variation with temperature change.....	450		
Voltmeter, use in determining output of generator.....	354		
W			
WAKEMAN, W. H., in "Power" on engine safety devices....	200		



UNIVERSITY OF CALIFORNIA LIBRARY

This book is DUE on the last date stamped below.

Fine schedule: 25 cents on first day overdue

50 cents on fourth day overdue

One dollar on seventh day overdue.

ENGINEERING LIBRARY

JAN 25 1948	DEC 11 1950	NOV 1954
APR 16 1948	JAN 11 1951	MAY 31 1955
JAN 2 1949	DEC 29 1951	OCT 1 1955
JAN 5 1949	JAN 19 1952	NOV 19 1955
MAY 20 1949	NOV 7 1952	DEC 6 1955
NOV 4 - 1949	JAN 27 1953	JAN 19 1956
MAR 15 1950	MAY 5 1953	
APR 9 1950	OCT 15 1954	
MAY 25 1950		
JUN 1 1950		
OCT 28 1950		
OCT 20 1950		

YC 33283

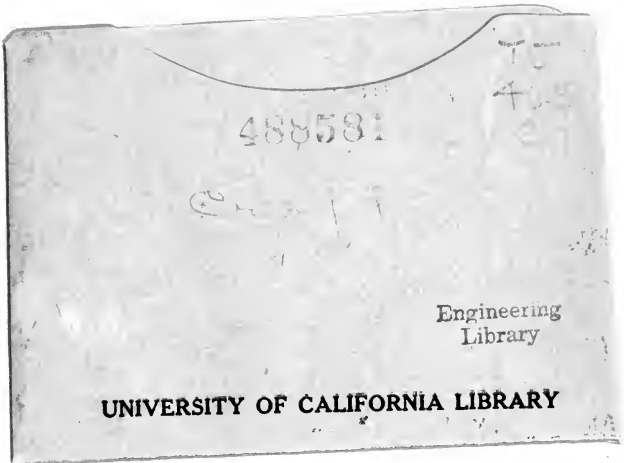

488581

75
40-5

Engineering
Library

UNIVERSITY OF CALIFORNIA LIBRARY

