

UC-NRLF

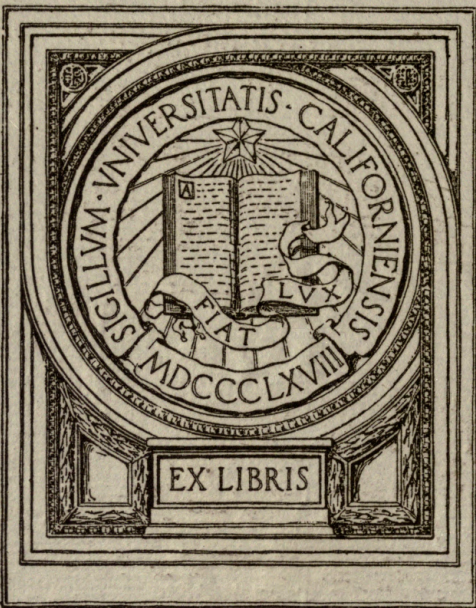

QB 315 399



EX LIBRIS

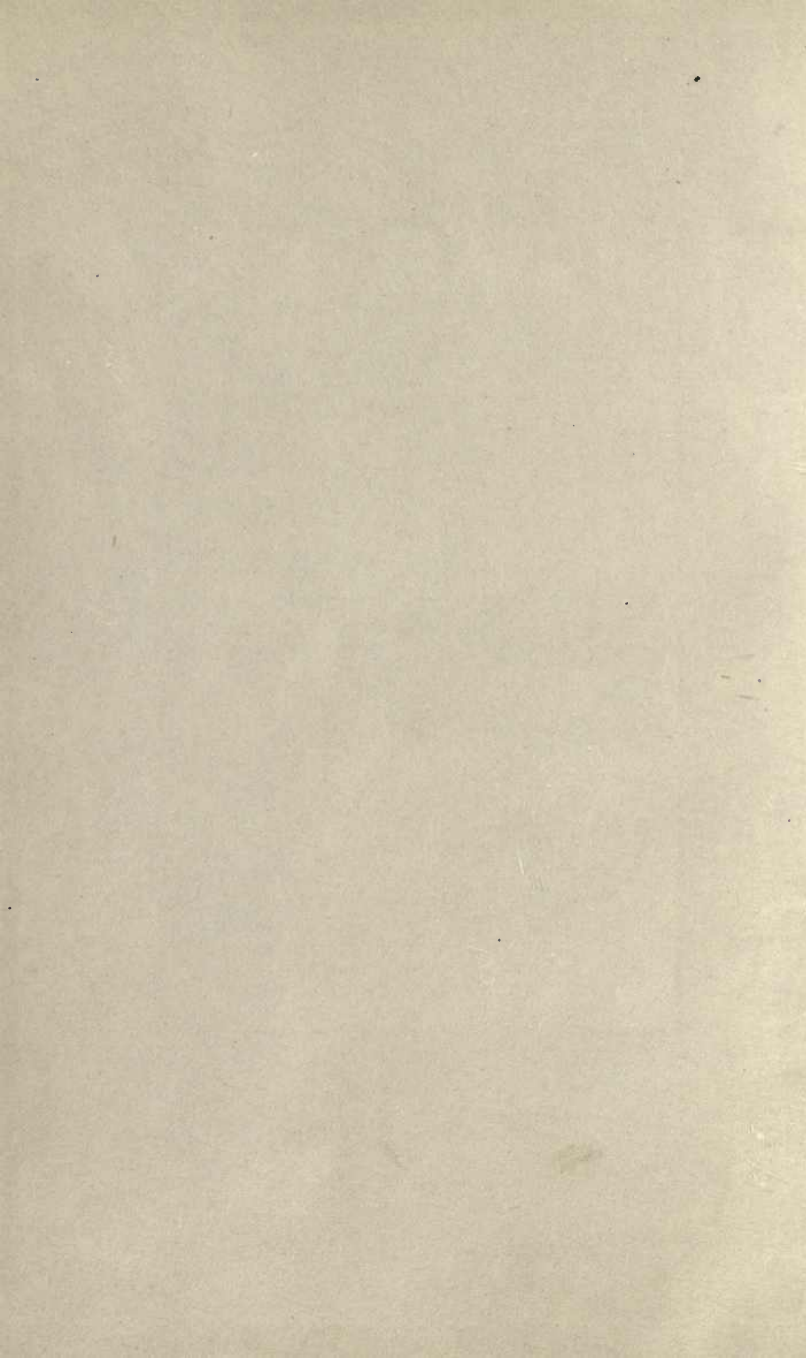

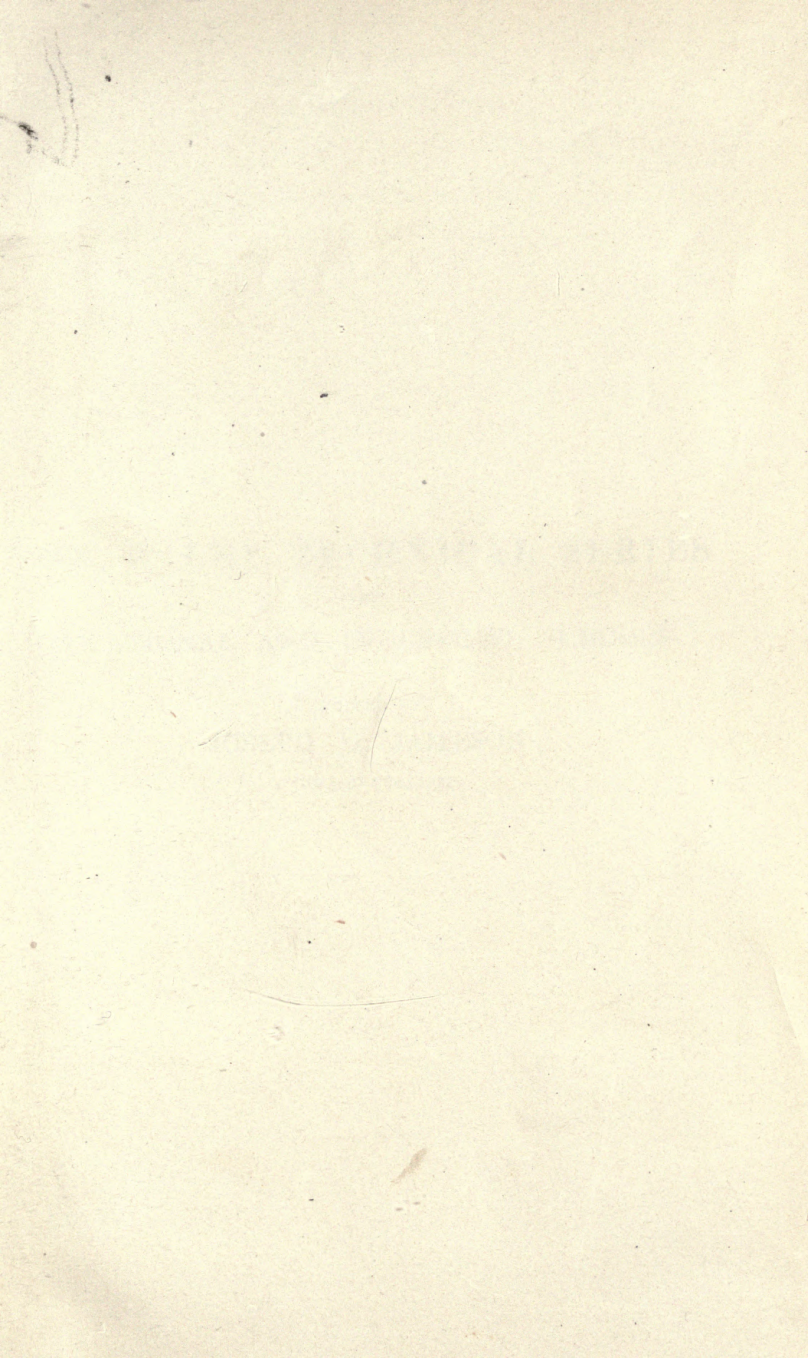

5057

THE WILEY TECHNICAL SERIES

FOR

VOCATIONAL AND INDUSTRIAL SCHOOLS

EDITED BY

JOSEPH M. JAMESON

GIRARD COLLEGE

THE WILEY TECHNICAL SERIES

EDITED BY

JOSEPH M. JAMESON

TEXT BOOKS IN MECHANICS, HEAT AND POWER

NOW READY

Steam Power. By C. F. HIRSHFELD, Professor of Power Engineering, Sibley College, Cornell University, and T. C. ULBRICHT. viii + 420 pages, 5½ by 8. 228 figures. Cloth, \$2.00 net.

Gas Power. By C. F. HIRSHFELD, Professor of Power Engineering, Sibley College, Cornell University, and T. C. ULBRICHT, Formerly Instructor, Department of Power Engineering, Cornell University. x + 209 pages, 5½ by 8, 60 figures. Cloth, \$1.25 net.

Heat: A Text Book for Technical and Industrial Students. By J. A. RANDALL, Pratt Institute. xiv + 331 pages, 5½ by 8, 80 figures. \$1.50 net.

Elementary Practical Mechanics. By J. M. JAMESON, Girard College. xii + 321 pages, 5½ by 8, 212 figures. Cloth, \$1.50 net.

Continuous and Alternating Current Machinery. By Professor J. H. MORECROFT, Columbia University. ix + 466 pages, 5½ by 8, 288 figures. Cloth, \$1.75 net.

Applied Mechanics Laboratory Manual. By J. P. KOTTKAMP, M.E., Instructor in Steam and Strength of Materials, Pratt Institute. 8 by 10½. Loose Leaf. 55 exercises with numerous cuts and tables. Complete, paper cover, \$1.00 net.

Exercises in Mechanics. By J. M. JAMESON, Girard College, Formerly Pratt Institute. 8 by 10½. Loose Leaf. 52 exercises. Complete, paper cover, 85 cents net.

Exercises in Heat. By J. A. RANDALL, Pratt Institute. 8 by 10½. Loose Leaf. 13 exercises. Complete, paper cover, 26 cents net.

For full announcement see list following index.

STEAM POWER

BY

C. F. HIRSHFELD, M. M. E.

PROFESSOR OF POWER ENGINEERING, SIBLEY COLLEGE, CORNELL UNIVERSITY

AND

T. C. ULBRICHT, M. E., M. M. E.

FORMERLY INSTRUCTOR, DEPARTMENT OF POWER ENGINEERING, SIBLEY COLLEGE,
CORNELL UNIVERSITY; ASSOCIATE MEMBER AMERICAN
SOCIETY OF MECHANICAL ENGINEERS

FIRST EDITION

FIRST THOUSAND

NEW YORK

JOHN WILEY & SONS, INC.

LONDON: CHAPMAN & HALL, LIMITED

1916

TJ275
H56

COPYRIGHT, 1916, BY
C. F. HIRSHFELD AND T. C. ULBRICHT

PRESS OF
BRAUNWORTH & CO.
BOOKBINDERS AND PRINTERS
BROOKLYN, N. Y.

PREFACE

THE following pages represent the results of an attempt to collect in a comparatively small book such parts of the field of steam power as should be familiar to engineers whose work does not require that they be conversant with the more complicated thermodynamic principles considered in advanced treatments. The experience of the authors has led them to believe that a book of this sort should give a correct view-point with regard to the use of heat in the power plant even though it does not enter deeply into the theoretical considerations leading up to that view-point; that it should supply the tools required for the solution of power plant problems of the common sort; and that it should give sufficient description of power plant apparatus to make the reader fairly familiar with the more common types.

Mathematical treatment of the subject has been eliminated to the greatest possible extent, and anyone familiar with elementary algebra should be able to understand readily such equations as it has been deemed necessary to include.

Brief explanations of physical and chemical concepts are given in every case in which the text required their use, so that those who have not studied these subjects, and those who have but have failed to crystallize and hold the neces-

sary ideas, should have little difficulty in reading the text understandingly.

It is hoped that the book may prove serviceable as a text for steam power courses given to civil engineers in the various colleges and that it may also meet the needs of those instructing power plant operators in industrial schools.

C. F. H.

T. C. U.

JUNE, 1916.

CONTENTS

CHAPTER I

	PAGE
PHYSICAL CONCEPTIONS AND UNITS.....	1
1. Matter. 2. Energy. 3. Units of Matter and Energy.	
4. Work. 5. Mechanical Energy. 6. Heat. 7. Temperature.	
8. Measurement of Temperature. 9. The Unit of Heat Energy.	
10. Specific Heat. 11. Quantity of Heat.	
12. Work and Power.	

CHAPTER II

THE HEAT-POWER PLANT.....	20
13. The Simple Steam-power Plant. 14. Cycle of Events.	
15. Action of Steam in the Cylinder. 16. Hydraulic Analogy.	

CHAPTER III

STEAM.....	27
17. Vapors and Gases. 18. Properties of Steam. 19. Generation of Steam or Water Vapor.	
20. Heat of Liquid, q or h . 21. Latent Heat of Vaporization, r or L .	
22. Total Heat of Dry Saturated Steam, λ or H . 23. Total Heat of Wet Steam.	
24. Heat of Superheat. 25. Total Heat of Superheated Steam.	
26. Specific Volume of Dry Saturated Steam, V or S .	
27. Specific Density of Dry Saturated Steam, $\frac{1}{V}$ or δ .	
28. Reversal of the Phenomena Just Described.	
29. Generation of Steam in Real Steam Boiler.	
30. Gauge Pressure.	

CHAPTER IV

THE IDEAL STEAM ENGINE.....	43
31. The Engine. 32. Operation of the Engine. 33. Work Done by the Engine.	
34. Heat Quantities Involved. 35. Efficiency. 36. Effect of Wet Steam.	
37. Application to	

a Real Engine. 38. Desirability of Other Cycles. 39. The Complete Expansion Cycle. 40. The Incomplete Expansion Cycle.

CHAPTER V

ENTROPY DIAGRAM.....	61
41. Definitions. 42. Temperature-Entropy Chart for Steam. 43. Quality from $T\phi$ -Chart. 44. Volume from $T\phi$ -chart. 45. Heat from $T\phi$ -chart. 46. The Complete $T\phi$ -chart for Steam.	

CHAPTER VI

TEMPERATURE ENTROPY DIAGRAMS OF STEAM CYCLES.....	72
47. Complete-expansion Cycle. 48. Area of Cycle Representative of Work. 49. Modifications for Wet and Superheated Steam. 50. Incomplete Expansion Cycle. 51. Effect of Temperature Range on Efficiency.	

CHAPTER VII

THE REAL STEAM ENGINE.....	77
52. Operations of Real Engine. 53. Losses in Real Installations. 54. Clearance. 55. Cushion Steam and Cylinder Feed. 56. Determination of Initial Condensation. 57. Methods of Decreasing Cylinder Condensation. 58. Classification of Steam Engines. 59. Rotative Speeds and Piston Speeds. 60. The Simple D-Slide Valve Engine. 61. Engine Nomenclature. 62. Principal Parts of Engines.	

CHAPTER VIII

THE INDICATOR DIAGRAM AND DERIVED VALUES.....	115
63. The Indicator. 64. Determination of I.h.p. 65. Conventional Diagram and Card Factors. 66. Ratio of Expansion. 67. Determination of Clearance Volume from Diagram. 68. Diagram Water Rate. 69. $T\phi$ -diagram for a Real Engine. 70. Mechanical and Thermal Efficiencies.	

CHAPTER IX

COMPOUNDING.....	141
71. Gain by Expansion. 72. Compounding. 73. The Compound Engine. 74. Cylinder Ratios. 75. Indicator Diagrams and Mean Pressures. 76. Combined Indicator Diagrams.	

CHAPTER X

	PAGE
THE D-SLIDE VALVE.....	159
77. Description and Method of Operation. 78. Steam Lap. 79. Lead. 80. Angle of Advance. 81. Exhaust Lap. 82. The Bilgram Diagram. 83. Exhaust and Compression. 84. Diagram for Both Cylinder Ends. 85. Piston Positions. 86. Indicator Diagram from Bilgram Diagram. 87. Limitations of the D-slide Valve. 88. Reversing Engines. 89. Valve Setting.	

CHAPTER XI

CORLISS AND OTHER HIGH-EFFICIENCY ENGINES.....	196
90. The Trip-cut-off Corliss Engine. 91. Non-detaching Corliss Gears. 92. Poppet Valves. 93. The Una-flow Engine. 94. The Locomobile Type.	

CHAPTER XII

REGULATION.....	213
95. Kinds of Regulation. 96. Governor Regulation. 97. Methods of Varying Mean Effective Pressure. 98. Constant Speed Governing. 99. Governors.	

CHAPTER XIII

THE STEAM TURBINE.....	221
100. The Impulse Turbine. 101. Theoretical Cycle of Steam Turbine. 102. Nozzle Design. 103. Action of Steam on Impulse Blades. 104. De Laval Impulse Turbine. 105. Gearing and Staging. 106. The Reaction Type. 107. Combined Types. 108. Economy of Steam Turbines.	

CHAPTER XIV

CONDENSERS AND RELATED APPARATUS.....	251
109. The Advantage of Condensers. 110. Measurement of Vacuums. 111. Conversion of Readings from Inches of Mercury to Pounds per Square Inch. 112. Principle of the Condenser. 113. Types of Condensers. 114. The Jet Condenser. 115. Non-Contact Condensers. 116. Water Required by Contact Condensers. 117. Weight of Water Required by Non-contact Condensers. 118. Relative Advantages of Contact and Surface Condensers. 119. Cooling Towers.	

CHAPTER XV

	PAGE
COMBUSTION.....	277
120. Definitions. 121. Combustion of Carbon. 122. Combustion to CO. 123. Combustion to CO ₂ . 124. Combustion of CO to CO ₂ . 125. Conditions Determining Formation of CO and CO ₂ . 126. Flue Gases from Combustion of Carbon. 127. Combustion of Hydrogen. 128. Combustion of Hydrocarbons. 129. Combustion of Sulphur. 130. Combustion of Mixtures. 131. Temperature of Combustion.	

CHAPTER XVI

FUELS.....	296
132. Commercial Fuels. 133. Coal. 134. Coal Analyses. 135. Calorific Value of Coals. 136. Purchase of Coal on Analysis. 137. Petroleum.	

CHAPTER XVII

STEAM BOILERS.....	305
138. Definitions and Classifications. 139. Functions of Parts. 140. Furnaces and Combustion. 141. Hand Firing. 142. Mechanical Grates. 143. Smoke and its Prevention. 144. Mechanical Stokers. 145. Rate of Combustion. 146. Strength and Safety of Boiler. 147. Circulation in Boilers. 148. Types of Boilers. 149. Boiler Rating. 150. Boiler Efficiencies. 151. Effects of Soot and Scale. 152. Scale. 153. Scale Prevention. 154. Superheaters. 155. Draft Apparatus.	

CHAPTER XVIII

RECOVERY OF WASTE HEAT.....	375
156. Waste Heat in Steam Plant. 157. Utilization of Exhaust for Heating Buildings. 158. Feed-water Heating.	

CHAPTER XIX

BOILER-FEED PUMPS AND OTHER AUXILIARIES.....	382
159. Boiler-feed Pumps. 160. The Steam Injector. 161. Separators. 162. Steam Traps. 163. Steam Piping.	

STEAM POWER

CHAPTER I

PHYSICAL CONCEPTIONS AND UNITS

1. Matter. The universe is generally pictured as composed of matter and energy. Matter is regarded as that which is possessed of mass, or as that which is possessed of inertia; i.e., which *requires the action of force to put it in motion, to bring it to rest or to change its velocity.* These definitions merely enumerate characteristics of matter; they do not tell what it really is. In the present state of knowledge it is, however, impossible to define matter in any other way.

No experiment has yet shown that matter can be created or destroyed by man. It can be changed from one form to another, it can be given certain physical and certain chemical characteristics, more or less at will, but the actual quantity of matter concerned is always the same after and before such changes. It is customary to state this experience in the form of a law known as the **Law of the Conservation of Matter**, which states that the "*total quantity of matter in the universe is constant.*"

Matter is known to exist in several physical states or conditions of aggregation. The three most familiar are (1) *solid*, (2) *liquid* and (3) *gaseous*. In each of these states matter is conceived as made up of minute particles called molecules which in turn are apparently composed of still smaller parts known as atoms. These atoms can also be broken into parts, but for the purposes of this book it is not necessary to consider such divisions.

Experiment and mathematical reasoning seem to indicate that the molecules of all materials are in constant motion and that there are neutralizing attractive and repulsive forces acting between them. In solids the molecules are apparently bound together in such a way that, although they are in constant motion, the external form or shape of the body tends to remain constant; in fact it requires the expenditure of force to cause a change of form. In liquids the molecular attraction is so altered that practically all rigidity disappears and the shape assumed by the liquid is determined by that of the surrounding surfaces, as, for instance, the shape of the vessel containing the liquid. In gases the molecules are still more free and actually tend to move apart as far as possible, so that a gas will spread in all directions until it fills any closed containing vessel.

2. Energy. Nearly everyone has a conception of what is meant by the term energy, but no one yet knows what energy really is. It is defined as *the capacity for doing work, or the ability to overcome resistance*. A man is said to be very energetic or to be possessed of a great deal of energy when he has the ability to perform a great amount of work or to overcome great resistances. Matter is said to be possessed of energy when it can perform work or overcome resistance. Actually, matter is not known in any form in which it is not possessed of energy.

There are many different forms of energy. A body in motion can do work and is said to be possessed of **mechanical energy**. A body which we recognize as hot can do work at the expense of the heat associated with it and is said to be possessed of **heat energy**. Light, sound and electricity are all forms of energy.

Experiment and experience have never shown that energy can be destroyed or created by man, but they have shown that one form of energy can be converted into another form under proper conditions. The first part of this experience is stated as a law known as the **Law of the Conservation of**

Energy. This law states that “*the total quantity of energy in the universe is constant.*”

3. Units of Matter and of Energy. When attempts are made to measure the amount of anything, some unit of measurement is adopted. Matter is measured in numerous ways and many units are used. The common methods of measuring matter are by volume and by weight. Engineers in English-speaking countries use the cubic yard, the cubic foot or the cubic inch as units in measuring matter by volume and they use the pound, the ounce, the grain, etc. as units in measuring matter by weight.

Energy is measured in many units and, in general, there is a characteristic unit or set of units for each form in which it occurs. Thus the **foot-pound** is very commonly used for measuring *mechanical energy*; the **British thermal unit** for measuring *heat energy*; and the **joule** for measuring *electrical energy*. Some of these units will be defined and considered in greater detail in subsequent paragraphs.

4. Work. Work is defined as *the overcoming of a resistance through a distance*. Thus, work is done when a weight is raised against the resistance offered by gravity; work is done when a spring is compressed against the resistance which the metal offers to change of shape; work is done when a body is moved over another against the resistance offered by friction.

The unit of work is the quantity of work which must be done in *raising a weight of one pound through a vertical distance of one foot*. It is called the **foot-pound**. Thus, one foot-pound of work must be done in raising one pound one foot; two foot-pounds of work must be done in raising two pounds one foot or in raising one pound two feet.

If a weight of one pound were suspended from a spring balance as shown in Fig. 1, the balance would indicate a pull or *force* of one pound. No work would be

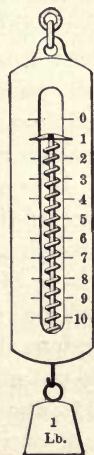

FIG. 1.

done by this force as long as the weight remained stationary, because no resistance would be overcome through a distance. If, however, the same weight were slowly or rapidly raised a vertical distance of a foot, one foot-pound of work would be done. A force or pull of one pound would then have overcome a resistance of one pound through a distance of one foot. In general:

$$\begin{aligned} \text{Work in ft.-lbs.} &= \text{Resistance overcome in lbs.} \times \text{distance.} \\ &= \text{Force in lbs.} \times \text{distance in ft.} \end{aligned}$$

so that if a force of 10 lbs. pushes or pulls anything which offers a resistance of 10 lbs. while that something travels a distance of, say, 5 ft., the work done will be given by the expression,

$$\begin{aligned} \text{Work} &= 10 \times 5, \\ &= 50 \text{ ft.-lbs.} \end{aligned}$$

A body in falling a certain distance can do work equal to its weight multiplied by the distance it falls because it could theoretically raise an equal weight an equal distance against the action of gravity, and the work done upon this second body would be equal to its weight multiplied by the distance through which it was raised.

It is very important to note that *no work is done by a force if there is no motion*; resistance must be overcome through a distance in order that work may be done. Thus, a force of 1000 lbs. might be required to hold something in position, that is to balance a resistance, but no work would be done if the body upon which the 1000-pound force acted did not move. Again, a weight of 50 lbs. held at a distance of 10 ft. above the surface of the earth would exert a downward push or pull equal to 50 lbs. on whatever held it in that position; it would, however, do no work if held in that position. If allowed to fall through the distance of 10 ft. it could do $50 \times 10 = 500$ ft.-lbs. of work.

It is very convenient to represent graphically the action

of forces overcoming resistances, that is, doing work. This is done by plotting points showing the magnitude of the force at the time that the body on which it is acting has traveled different distances. Thus, suppose a constant force of 10 lbs. pushes a body a distance of 15 ft. against a constant resistance of 10 lbs. The force acting on the body will have a value of 10 lbs. just as the body starts to move, a value of 10 lbs. when the body has moved 1 ft., a value of 10 lbs. when the body has moved 2 ft., and so on. This might be represented by points on squared paper as shown

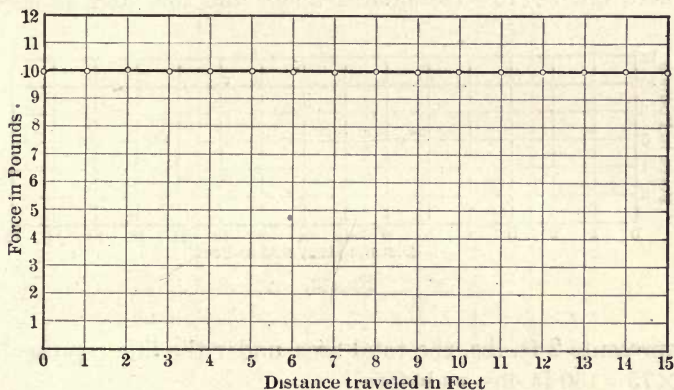

FIG. 2.

in Fig. 2 or by a horizontal line joining those points as shown in the same figure.

The work done by this force would be $10 \times 15 = 150$ ft.-lbs. according to our previous definition. But 10×15 is also the number of small squares under the line representing the action of this force in Fig. 2. The number of these small squares then must be a measure of the work done, but it is also a measure of the area under the line representing the action of the force, so that this area must be a measure of the work done. Each small square represents 1 lb. by its vertical dimension and 1 ft. by its horizontal dimension,

so that its area must represent $1 \text{ lb.} \times 1 \text{ ft.} = 1 \text{ ft.-lb.}$ The total number of squares below the line equals $10 \times 15 = 150$, and since the area of each one represents 1 ft.-lb. the total area under the line represents $150 \times 1 = 150 \text{ ft.-lbs.}$

It is not always convenient to choose such simple scales as those just used. Thus it might be more convenient to plot the action of this force as is done in Fig. 3. Here the height of a square represents 2 lbs. and the width represents 1 ft.; the area then represents $2 \times 1 = 2 \text{ ft.-lbs.}$ There are $5 \times 15 = 75$ squares under the line and as each

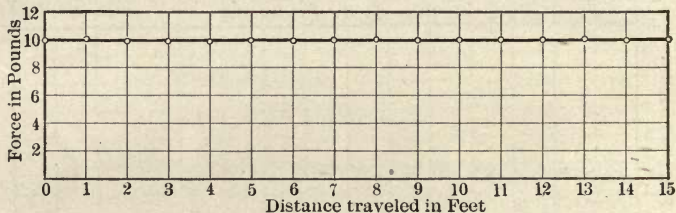

FIG. 3.

represents 2 ft.-lbs. the total area under the line represents $2 \times 75 = 150 \text{ ft.-lbs.}$ as before.

This is a very useful property of these diagrams and the area under the line representing the action of the force always represents the work done, no matter what the shape of that line.

Thus, assume a force which compresses a spring a distance of 6 ins. Suppose that a force of 10 lbs. is required to compress the spring 1 in., a force of 20 lbs. to compress it 2 ins., and so on up to a force of 60 lbs. to compress it 6 ins. Starting with a force of zero, the force will have to gradually increase as the spring is compressed, as shown by the line in Fig. 4. The area of each of the small squares will represent $10 \times \frac{1}{12} = \frac{10}{12} \text{ ft.-lbs.}$ Under the line there is an area equal

o $\frac{6 \times 6}{2} = 18$ small squares, and the work done in compressing the spring must then be $18 \times \frac{10}{12} = 15$ ft.-lbs.

5. Mechanical Energy. Any body which exists in such a position or location that it could do work by dropping or falling is said to be possessed of **potential mechanical energy**, or of mechanical energy *due to position*. As long as it remains in this position, it cannot do work at the expense of this energy, but, if allowed to fall, it could do so. The

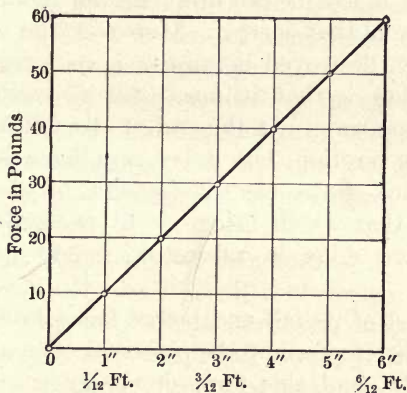

FIG. 4.—Graph Showing Action of Spring.

work it could do would be equal to the product of its weight by the distance it could fall and the potential energy it possesses before starting to fall is measured by this work. Thus, a body weighing 40 lbs. located 10 ft. above the surface of the earth could do $40 \times 10 = 400$ ft.-lbs. of work in falling, and, therefore, it is said to be possessed of 400 ft.-lbs. of potential energy before it starts to fall.

If in falling it raises a weight equal to its own (theoretically) through a distance equal to that through which it falls (theoretically), it will have used up 400 ft.-lbs. of energy in doing 400 ft.-lbs. of work upon the body raised

and will no longer be possessed of that amount of potential energy. The body which has been raised will, however, have an equal amount of energy stored in it and will in turn be able to do 400 ft.-lbs. of work if allowed to fall a distance of 10 ft.

If the body assumed above falls through a distance of 10 ft. without raising another body or doing an equivalent amount of work in some other way, it acquires a high velocity. When it arrives at the bottom of the fall of 10 ft., it certainly does not possess the 400 ft.-lbs. of potential energy which it had before dropping nor has it done work at the expense of that energy. Moreover, the energy could not have been destroyed because it is indestructible. The only conclusion is that it must still be possessed of this energy in some way. At the end of the fall it has lost its advantageous position, but it has acquired a high velocity, and experience shows that if brought to rest it can do work upon that which brings it to rest equal to what it could have done in raising a weight as previously described.

At the end of its fall and before being brought to rest, the body is therefore said to be possessed of energy by virtue of its velocity, and this form of energy is called **kinetic mechanical energy**. *The kinetic energy will be exactly equal to the potential energy which disappeared as the body fell.*

Any body which is moving is possessed of kinetic energy because it can do work on anything which brings it to rest. This energy is expressed by the equation,

$$\text{Kinetic Energy in ft.-lbs.} = \frac{1}{2} \times \frac{W}{32.2} \times V^2,$$

in which

W = the weight of the moving body in pounds.

V = the velocity in ft. per second, and

32.2 = a gravitational constant commonly represented by g

6. Heat. One of the most familiar forms of energy is *heat*, which manifests itself to man through the sense of touch. In reality every body with which man is familiar possesses an unknown amount of heat energy and it is assumed that this heat energy is in some way associated with the motions and relative positions of the molecules and their constituents.

For this reason heat is often described as **molecular activity** and is regarded as *energy stored up in a substance by virtue of its molecular condition*. Heat energy can be made to perform work in ways which will be discussed later and this is proof that it is a form of energy and not a material substance, as was once supposed.

Heat is observed and recorded by its effects on matter, producing changes in the dimensions or volumes of objects; changes of internal stress; changes of state, as ice to water and water to steam; changes of temperature; and electrical and chemical effects.

Neglecting certain atomic phenomena not yet well understood, the probable source of all heat energy appearing on the earth is the sun. Heat, however, may be obtained from mechanical and electrical energy; from chemical changes; from changes of physical state; from the internal heat of the earth.

7. Temperature. Man early realized that under certain conditions bodies felt "hotter" than under other conditions and gradually came to speak of the "degree of hotness" as the **temperature** of the body. It was later realized that what was really measured as the "hotness" or intensity of heat or temperature of a body was *the ability of that body to transmit heat to others* and that it had no connection with quantity of heat.

Thus, if the temperature of two adjacent bodies happened to be the same, one of them could not lose heat by transmitting it to the other, but if the temperature of one happened to be higher than that of another, the body at

higher temperature would always lose heat to the one at lower temperature.

As a means of *measuring temperature* certain arbitrary scales have been chosen. The **centigrade scale** of temperature, for instance, is based upon the temperatures of melting ice and boiling water under atmospheric pressure. The temperature difference between boiling water at atmospheric pressure and melting ice at atmospheric pressure is arbitrarily called one hundred degrees of temperature, and the temperature of the melting ice is called *zero*, making that of the boiling water *100 degrees*.

Any body which has such a temperature that it will not give heat to, or take heat from, melting ice is said to be at a temperature of zero degrees centigrade, represented as 0° C. Similarly, any body in such a condition that it will not give heat to or take heat from water boiling under atmospheric pressure is said to have a temperature of 100° C. A body with a temperature exactly half way between these two limits would then be said to have a temperature of 50° C.

8. Measurement of Temperature. The temperatures of bodies could be determined by bringing them in contact with such things as melting ice and boiling water and determining whether or not a transfer of heat occurred, but this would be a very cumbersome and unsatisfactory method. As a consequence many other means have been devised for the measurement of temperature.

One of the most common and convenient methods involves the use of what are known as **mercury thermometers**. These depend upon the fact that the expansion of mercury with changing temperature is very uniform over a wide temperature range. Thus, if mercury expands a certain amount when its temperature is raised from that of melting ice to that of boiling water, i.e., 100° C., it will expand just half as much when its temperature is raised half as high, and one-quarter as much when its temperature is raised one-quarter of the range from 0° to 100° C.

The thermometer is made by enclosing a small quantity of mercury in a glass tube fitted with a bulb at one end, as shown in Fig. 5. The lower end of the thermometer is immersed in melting ice and the point on the stem which is reached by the top of the mercury column is marked and labelled 0° C. The thermometer is then immersed in the steam from water boiling under atmospheric pressure and the point reached by the top of the mercury column is marked and labelled 100° C. The distance between the two marks is then divided into one hundred parts and each represents the distance which the end of the column of mercury will move when its temperature changes one centigrade degree.



FIG. 5.—Mercury Thermometer.

It is customary to extend this same scale below 0° and above 100° , carrying it, on expensive thermometers, as far in each direction as the approximation to a constant expansion on the part of the mercury and to constant properties of the glass justifies.

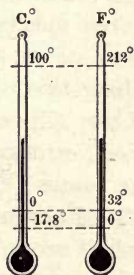

FIG. 6.—Comparison of Centigrade and Fahrenheit Scales.

The temperature of a body can then be found by placing the thermometer in or in contact with that body and noting the point reached by the end of the mercury column. The division reached gives the temperature directly.

The centigrade scale just described is the one commonly used by scientists the world over, but engineers in this country more often use what is known as the **Fahrenheit scale**. This is so chosen that the temperature of melting ice is called 32° F. and the temperature of water boiling under atmospheric pressure is called 212° F. There are

thus 180° on this scale for the same temperature difference as is represented by 100° on the centigrade scale. The relation between the two scales is shown diagrammatically in Fig. 6. It is apparent that the temperature of a body at 0° C. will be 32° F. and that of a body at 0° F. will be -17.8° C.

Since 100 centigrade degrees are equal to 180 Fahrenheit degrees, it follows that

$$1^\circ \text{ C} = \frac{180}{100} = \frac{9}{5}^\circ \text{ F.} \quad \dots \quad (1)$$

and that

$$1^\circ \text{ F} = \frac{100}{180} = \frac{5}{9}^\circ \text{ C.} \quad \dots \quad (2)$$

Therefore, if t_F and t_C represent temperatures on the Fahrenheit and centigrade scales respectively,

$$t_F = \frac{9}{5}t_C + 32. \quad \dots \quad (3)$$

and

$$t_C = \frac{5}{9}(t_F - 32) \quad \dots \quad (4)$$

There is still another temperature scale of great importance. It is known as the **absolute scale** and temperatures measured on it are spoken of as *absolute temperatures*. The zero on this scale is located at -273° C. or 273 centigrade degrees below centigrade zero, or, what is the same thing, at -459.4° F., or 459.4 Fahrenheit degrees below Fahrenheit zero. The degrees used are either centigrade

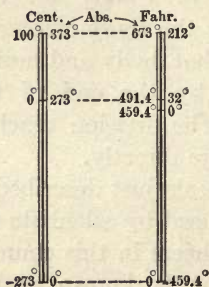

FIG. 7.—Comparison of Absolute and Ordinary Temperature Scales.

or Fahrenheit, as convenient, so that there are absolute temperatures expressed in centigrade degrees above absolute zero and there are absolute tempera-

tures expressed in Fahrenheit degrees above absolute zero. The relations between the various scales are shown diagrammatically in Fig. 7.

It is apparent from this diagram that,

$$T_F = t_F + 460 \text{ (approximately) (5)}$$

and that

$$T_C = t_C + 273 \text{ (6)}$$

if T_F and T_C represent absolute temperatures and if the number 459.4 is rounded out to 460, as is commonly done.

9. The Unit of Heat Energy. The unit used in the measurement of heat energy in the United States is the **British Thermal Unit** (abbreviated B.t.u). It is defined as *the quantity of heat required to raise the temperature of one pound of pure water one degree Fahrenheit*. In order to make the definition very exact it is necessary to state the temperature of the water before the temperature rise occurs, because it requires different amounts of heat to raise the temperature of a pound of water one degree from different initial temperatures. For ordinary engineering purposes, however, such refinements generally may be omitted.

Many experimenters have shown that *heat energy and mechanical energy are mutually convertible*, that is, the one can be changed into the other. When such a change occurs no energy can be lost since energy is indestructible, and it follows that, if one form is changed into the other, there must be just as much energy present after the change as there was before.

As the units used in measuring the two forms of energy are very different and as it is often necessary to express quantities of energy taking part in such conversions, it is desirable to determine the relations between these units. This was first accurately done by Joule, who showed that one British thermal unit of heat energy resulted from the con-

version of 772 ft.-lbs. of mechanical energy. Later experimenters have shown that the number 778 more nearly expresses the truth than does the number 772 and the larger value is now known as **Joule's Equivalent**.

Expressed mathematically, the relation between the units is

$$1 \text{ B.t.u.} = 778 \text{ ft.-lbs.} \quad \dots \quad (7)$$

$$1 \text{ ft.-lb.} = \frac{1}{778} \text{ B.t.u.} \quad \dots \quad (8)$$

10. Specific Heat. The specific heat of a substance is defined as *that quantity of heat which is used up or recovered when the temperature of one pound of the material in question is raised or lowered one degree.* Its numerical value depends upon the specific heat of water since the quantity of heat is measured in units dependent upon the amount required to raise the temperature of water. The specific heat of water is, however, very variable, as shown by the values given in Table I., and it is therefore evident that exact numerical values of specific heats can only be given when the definition of the B.t.u. is exactly expressed.

The specific heats of all real substances vary with temperature and the values commonly used are either rough averages or are those determined by experiments at one temperature. For most engineering purposes errors arising from this source may, however, be neglected.

From the definition of specific heat it follows that:

$$C = \frac{Q}{W(t_2 - t_1)}, \quad \dots \quad (9)$$

in which

C = a mean or average specific heat over a range of temperature from t_1 to t_2 , and

Q = the heat supplied to raise the temperature of W pounds of material from t_1 to t_2 .

TABLE I
SPECIFIC HEATS OF WATER.*
(Value at 55° F. taken as unity)

Temp. F°.	Spec. Ht.	Temp. F°.	Spec. Ht.
20	1.0168	350	1.045
30	1.0098	400	1.064
40	1.0045	450	1.086
50	1.0012	500	1.112
60	0.9990	510	1.117
70	0.9977	520	1.123
80	0.9970	530	1.128
90	0.9967	540	1.134
100	0.9967	550	1.140
120	0.9974	560	1.146
140	0.9986	570	1.152
160	1.0002	580	1.158
180	1.0019	590	1.165
200	1.0039	600	1.172
220	1.007		
240	1.012		
260	1.018		
280	1.023		
300	1.029		

* Values taken from Marks and Davis, "Steam Tables and Diagrams," p. 68.

ILLUSTRATIVE PROBLEMS

1. Given: Sp. ht. of iron = 0.113, of aluminum = 0.211; Initial temp. = 150° F. Temp. range ($t_2 - t_1$) = 100° F.

If 1 lb. of iron and 1 lb. of aluminum are cooled through this temperature range, how much more heat is lost in one case than in the other?

$$Q_{al} = WC_{al}(t_2 - t_1) = 1 \times .211 \times 100 = 21.1 \text{ B.t.u.}$$

$$Q_{ir} = WC_{ir}(t_2 - t_1) = 1 \times .113 \times 100 = 11.3 \text{ B.t.u.}$$

Difference 9.8 B.t.u.

2. If the difference obtained in Prob. 1 were used to heat up 5 lbs. of silver, with a specific heat equal to 0.057, what would be the temperature range through which it would be raised?

$$Q = 9.8 = 5 \times 0.057(t_2 - t_1) = 0.285(t_2 - t_1)$$

$$\therefore t_2 - t_1 = 34.4^\circ \text{ F.}$$

3. If the initial temperature of the silver in Prob. 2 were 150° F. what would be the final *absolute* temperature Fahr.?

$$t_2 = t_1 + 34.4^{\circ} = 150 + 34.4 = 184^{\circ} \text{ (approximately).}$$

$$T_2 = 460 + 184 = 644^{\circ} \text{ F. Abs.}$$

4. 100 lbs. of water in a 20-lb. tank of iron, both at 60° F., are placed in salt brine at 0° F. The water becomes ice at 32° F. and the temperature of the ice is lowered to 26° F., the brine being raised to 26° F. Sp. ht. water = 1.0; Sp. ht. ice = 0.5; Sp. ht. iron = 0.113; Sp. ht. brine = 0.8; and 143 B.t.u. per pound of water must be removed to convert liquid water at 32° F. to ice at the same temperature. What weight of brine is required?

$$100[1(60 - 32) + 143 + .5(32 - 26)] + 20 \times 0.113(60 - 26) \\ = W \times 0.8(26 - 0)$$

$$W = 840 \text{ lbs. of brine.}$$

11. Quantity of Heat. It is impossible to determine the total quantity of heat in or "associated with" a substance, because no means of removing and measuring all the heat contained in any real material have ever been devised. Since, however, the engineer is concerned with changes of heat content rather than with the total amount of heat contained, this fact causes him no difficulty.

For convenience in figuring changes of heat content, it is customary to *assume some arbitrary starting point or datum* and to call the heat in the material in question zero at that point.

Thus, for example, if it were necessary to figure heat changes experienced by a piece of iron weighing 5 lbs. and having a specific heat of 0.1138, and the temperature of this iron never dropped below 40° F. under the conditions existing, this temperature might be taken as an arbitrary starting point above which to figure heat contents. If the iron were later found at a temperature of 75° F., "the heat content above 40° F." would be said to be

$$Q = CW (t_2 - t_1) = 0.1138 \times 5(75 - 40) = 2.27 \text{ B.t.u.}$$

This type of formula can only be used when the substance does not change its state between the limits of temperature concerned. In the case of water which might change to steam during such a rise of temperature, it might be necessary to include other heat quantities in the calculations, as shown in a later chapter.

12. Work and Power. Since steam engines are designed for the purpose of converting the heat energy contained in fuel into mechanical energy which may be used to perform work, it will be necessary to consider the units used in measuring work and power.

Work was defined in a previous paragraph as *the overcoming of a resistance through a distance*, by the application of a force; that is, *a force expressed in pounds, multiplied by the distance in feet through which the force acts, gives a product expressed in foot-pounds.*

The amount of work performed in a *unit of time* is termed **power**, which may be defined as the rate of doing work. Therefore,

$$\text{Power} = \frac{\text{Force} \times \text{Distance}}{\text{Time (min. or sec.)}} \quad \dots \quad (10)$$

The unit of power used by steam engineers is the **horse-power**, which is equivalent to the performance of *33,000 ft.-lbs. of work per minute*, or 550 ft.-lbs. of work per second, or 1,980,000 ft.-lbs. per hour. Therefore, the horse-power developed by any mechanism is

$$\text{h.p.} = \frac{\text{ft.-lbs. of work per min.}}{33,000} \quad \dots \quad (11)$$

Since 33,000 ft.-lbs. of work can be accomplished only by the expenditure of 33,000 ft.-lbs. of energy and since one B.t.u. of energy is equal to 778 ft.-lbs., it follows that 33,000 ft.-lbs. of work must be the equivalent of $\frac{33,000}{778} = 42.41$ B.t.u.

It is customary to speak of power in terms of **horse-**

power-hours. One horse-power-hour means the doing of work equivalent to one horse-power for the period of one hour, or the doing of work at the rate of *33,000 ft.-lbs. per minute for an hour*. A horse-power-hour is therefore equivalent to $33,000 \times 60 = 1,980,000$ ft.-lbs. As 33,000 ft.-lbs. are equivalent to 42.41 B.t.u., it follows that $42.41 \times 60 = 2544.6$ or about 2545 B.t.u. are the equivalent of one horse-power-hour.

The number 2545 should be memorized as it is very often used in steam-power calculations. If an engine could deliver one horse-power-hour for every 2545 B.t.u. it received, it would be working without losses of any kind; that is, all the heat energy entering it would leave it in the form of useful mechanical energy. It will be shown later that this is impossible even in the most perfect or ideal engine.

REVIEW PROBLEMS

1. Express 32° F. in degrees centigrade.
2. Express 150° F. in degrees centigrade.
3. Express 250° C. in degrees Fahrenheit.
4. Express the results of problems 1, 2 and 3 in absolute values.
5. What is the heat equivalent of 233,400 ft.-lbs. of work?
6. Find the heat supplied 10 lbs. of water when its temperature is raised from 20° F. to 160° F., assuming the mean specific heat over this range to be 0.997.
7. Find the temperature change of 2 lbs. of lead (sp. ht. 0.0314) when 20 B.t.u. are added.
8. How many B.t.u. must be abstracted to lower the temperature of 15 lbs. of water from 212° F. to 32° F., assuming the specific heat of water to be unity?
9. Find the weight of water which will have its temperature tripled in value by the addition of 250 B.t.u., the final temperature being 150° F. Assume specific heat unity.
10. The specific heat of a piece of wrought iron is 0.113 and of a given weight of water is 1.015. 1 cu. ft. of water weighs approximately 62.5 lbs. Find the increase in temperature of 4 cu. ft. of water when a common temperature of 65° F. results from placing in the water a piece of iron weighing 15 lbs. at a temperature of 900° F.

11. Find the final temperature of the mixture, when 100 lbs. of iron (sp. ht. = 0.113), at a temperature of 1200° F. are immersed in 300 lbs. of water (sp. ht. 1.001) at a temperature of 50° F.

12. Five pounds of silver (sp. ht. = 0.057) at 800° F. are immersed in water at 60° F., resulting in a final temperature of 85° F. Assume Sp. ht. water = 1. What weight of water is necessary?

13. An engine is developing 10 horse-power. Express this in ft.-lbs. of work done per minute and find the amount of heat energy equivalent to this quantity of mechanical energy.

14. A pump raises 1000 lbs. of water 50 ft. every minute. How much work is done? Find the equivalent horse-power.

15. An engine develops 1,980,000 ft.-lbs. of work at the fly-wheel per minute.

(a) Find the horse-power developed.

(b) If this engine operated in this way for an hour, how many horse-power hours would it make available?

(c) What would be the equivalent of this number of horse-power hours in British thermal units?

CHAPTER II

THE HEAT-POWER PLANT

13. The Simple Steam-Power Plant. The various pieces of apparatus necessary for the proper conversion of heat energy into mechanical power constitute what may be called a "Heat-Power Plant," just as the apparatus used in obtaining mechanical energy from moving water is called an hydraulic or water-power plant. Heat-power plants are distinguished as "Steam-Power Plants"; "Gas-Power Plants"; etc., according to the way in which the heat of the fuel happens to be utilized.

The apparatus around which the plant as a whole centers, that is, the apparatus in which heat energy is received and from which mechanical energy is delivered, is termed the **engine** or **prime-mover**. This heat engine may use *steam* generated in boilers and may require certain apparatus, such as condensers, pumps, etc., for proper operation; or it may use *gas*, generated in gas-producers requiring coolers, scrubbers, tar extractors and holders, depending upon the class of fuel used and upon certain commercial considerations. Again, the power-plant may simply contain an internal-combustion engine using natural gas, gasoline or oil, a type of plant which is now very common.

But whatever type of plant is used, a general method of operation is common to all. *Heat energy in fuel is constantly fed in at one end of the system and mechanical energy is delivered at the other end.* The steam-power plant will be briefly described in the following paragraphs, showing the cycle of events with the attendant losses through the system.

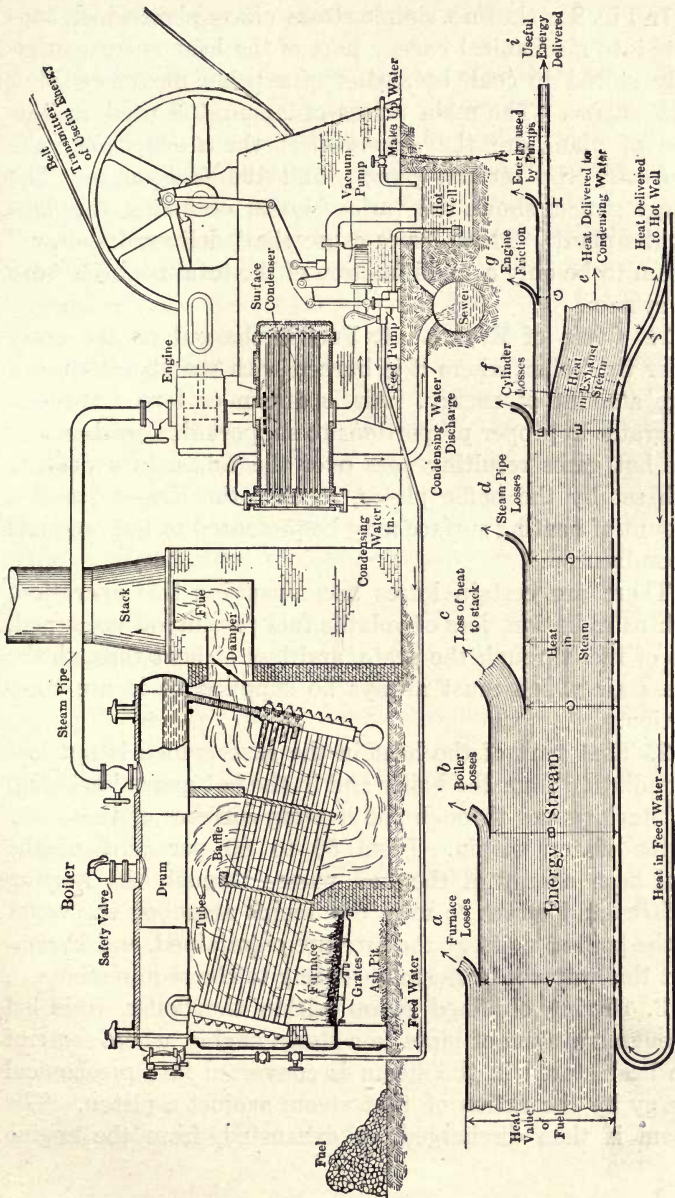

FIG. 8.—Elements of a Steam Power Plant.

In Fig. 8 is shown a simple steam-power plant which converts into mechanical energy part of the heat energy, originally stored in coal, by means of a prime-mover called a *steam-engine*. The main pieces of apparatus used in this type of plant are the *steam-boiler*; the *steam-engine*; the *condenser*; the *vacuum pump*; and the *feed-pump*. The energy stream shows the various losses occurring throughout the plant. These losses cause the "delivered energy" stream to be only a small fraction of the total heat sent into the system.

14. Cycle of Events. 1. Fuel is charged on the grate under the boiler, where it is burned with the liberation of a large amount of energy. Air is drawn or forced through the grates in proper proportions to support this combustion. The hot gases resulting pass over the tubes, in a definite path set by the baffle plates, so that the largest possible amount of heating surface may be presented to the products of combustion.

There are certain losses accompanying this operation, such as radiation, loss of volatile fuel passing off unburned, loss of fuel through the grate, and loss of heat through the excess air which must always be supplied to insure combustion.

2. That part of the heat in the gases which is not lost by radiation from the boiler and in the hot gases flowing up the stack passes through the heating surfaces of the boiler to the water within. From 50 to 80 per cent of the total heat energy in the fuel passes through the heating surfaces and serves to raise the temperature of the water to the boiling point at the pressure maintained, and to convert this water into steam according to the requirements.

3. Having obtained steam within the boiler, it is led through a system of pipes to a steam engine, where some of the heat stored in the steam is converted into mechanical energy by the action of that steam against a piston. The steam is then discharged, or exhausted, from the engine

at a much lower temperature and pressure than when it entered.

From 5 to 22 per cent of the available heat in the steam is converted into mechanical energy in the engine cylinder, and because of frictional and other losses occurring in the mechanism, only from 85 to 95 per cent of this energy is turned into useful work at the fly-wheel.

4. In some plants, known as **non-condensing plants**, the exhaust steam, which still contains the greater part of all the heat received in the boiler, is discharged to the atmosphere and represents a complete loss. In others, known as **condensing plants**, the exhaust steam is led to a condenser, where it is condensed by cold water, which absorbs and carries away the greater quantity of the heat not utilized in the engine. The condensed steam or "condensate" is then either discharged to the sewer or transferred by means of a *vacuum-pump* to the *hot-well*, from which it is drawn by means of the *feed-water-pump*, raised to the original pressure of the steam, and returned to the boiler. Here it is again turned into steam and the cycle of operations outlined above is repeated. Naturally there is some loss due to evaporation and leaks throughout the system, so that "make-up" water must constantly be supplied.

The series of events just described constitutes a complete, closed **cycle** of operations, wherein the water is heated, vaporized, condensed and returned to the boiler, having served only as a medium for the transfer of heat energy from fuel to engine and the conversion of part of that energy within the cylinder. The water in such a case is known as the *working substance*.

It is often more convenient to discard the working substance after it leaves the cylinder, as suggested above in the case of a non-condensing plant; or, as in the case of a gas engine, where a new supply of working substance must be supplied for each cycle, because the burned gases of the previous cycle cannot be used again.

15. Action of Steam in the Cylinder. In order to prepare for the more detailed discussion of the action of the steam in the engine cylinder, to be taken up in a later chapter, a brief outline of the events occurring within the prime-mover will be considered at this point.

Steam enters the cylinder through some kind of an *admission valve*, and acts upon the piston, just as the latter has approximately reached one end of its stroke and is ready to return. The heat-energy stored up in the steam causes it to expand behind the piston, thereby driving the latter out and performing work at the fly-wheel. At about 90 or 95 per cent of the stroke, the exhaust valve opens, and the steam begins to exhaust, the pressure within the cylinder dropping almost to atmospheric or to that maintained in the condenser by the time the piston has reached the end of its stroke. On the next or return stroke the remaining steam is forced out through the exhaust port, until, at some point before the end of the piston-travel, the exhaust valve closes, and the low-pressure steam trapped in the cylinder is compressed into the clearance space so that its pressure rises. Admission then occurs, and the cycle is repeated.

The diagram given in Fig. 9 illustrates the operation of steam within the cylinder.

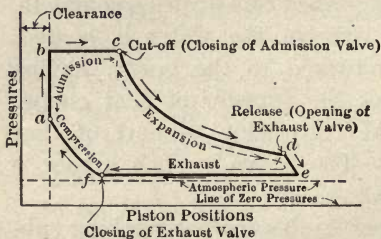

FIG. 9.—Steam Engine Indicator Diagram.

This diagram is plotted between pressures of steam within the cylinder as ordinates and corresponding piston positions as abscissas.

The method of obtaining such a diagram, known as an **indicator-diagram**, will be fully described in a

later chapter. Since vertical ordinates represent pressure in pounds per square inch, and horizontal abscissas repre-

sent feet moved through by the piston, the product of these two must be work. But the product of vertical by horizontal distances must also give area. Therefore, by

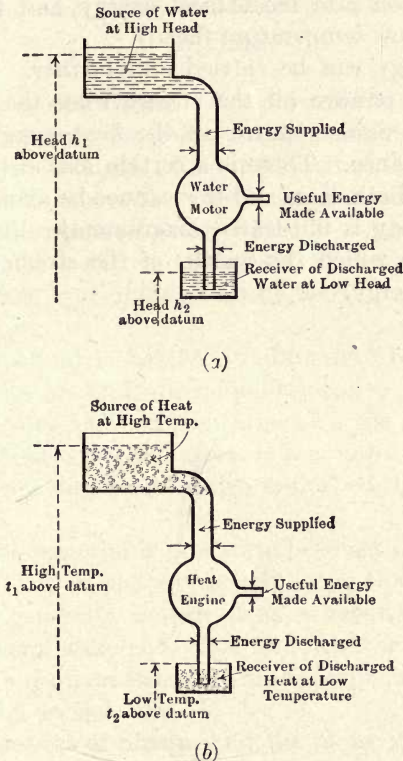

FIG. 10.—Hydraulic Analogy.

finding the area enclosed within the bounding lines of the cycle and multiplying this by a proper factor, the foot-pounds of work developed within the cylinder can be determined.

16. Hydraulic Analogy. The operation of heat-engines is analogous to that of water-wheels. A water-wheel de-

velops mechanical energy by receiving water under a high head, absorbing some of its energy, and then rejecting the fluid under a low head. Similarly, the heat-engine receives heat energy at a high temperature (head), absorbs some of it by conversion into mechanical energy, and then rejects the rest at a low temperature (head).

The analogy can be carried still further. The water-wheel cannot remove all the energy from the water, nor can the heat-engine remove all the heat-energy from the working substance. There is a certain loss in the material discharged in both cases and this cannot be avoided.

This analogy is illustrated diagrammatically in Fig. 10 (a) and (b) in which the widths of the streams represent quantity of energy.

CHAPTER III

STEAM

17. Vapors and Gases. When a solid is heated, under the proper pressure conditions, it ultimately melts or fuses and becomes a liquid. The temperature at which this occurs depends upon the particular material in question and upon the pressure under which it exists. Ice, which is merely solid water, melts at 32° F. under atmospheric pressure, while iron melts at about 2000° F. under atmospheric pressure.

When a liquid is heated, it ultimately becomes a gas, similar to the air and other familiar gases. If this gas is heated to a very high temperature and if the pressure under which it is held is not too great, it *very nearly* obeys certain laws which are simple and which are called the *laws of ideal gases*.

When the material is in a state between that of a liquid and that in which it very nearly obeys the laws of ideal gases, it is generally spoken of as a **vapor**. This term is used in several different ways and with several different modifying adjectives which will be explained in greater detail in later sections.

18. Properties of Steam. Of the many vapors used by the engineer, steam or water vapor is probably the most important, because of the ease with which it can be formed and also because of the tremendous field in which it can be used. It is generated in a vessel known as a *steam boiler*, which is constructed of metal in such a way that it can contain water, and that heat energy, liberated from burning fuel, can be passed into the water, converting part or all of it into water vapor, that is, into steam.

The properties of water vapor must be thoroughly understood before the steam engine and steam boiler can be studied profitably. Probably the easiest way of becoming familiar with these properties is to study the use made of heat in the generation of steam from cold water.

19. Generation of Steam or Water Vapor. For the purposes of development, assume a vessel of cylindrical form, fitted with a frictionless piston of known weight, as shown in Fig. 11, (a) and (b), the whole apparatus being placed under a bell-jar in which a perfect vacuum is maintained.

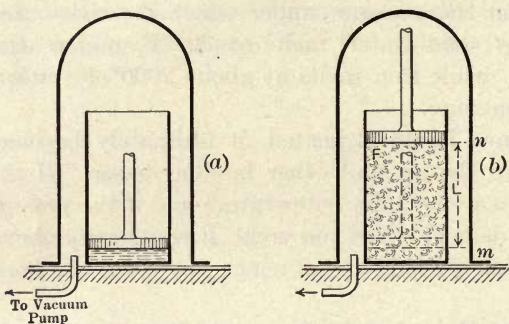

FIG. 11.—Formation of Steam at Constant Pressure.

Assume *one pound* of water in the cylinder, with the piston resting on the surface of the liquid. There will be some definite pressure exerted by the piston upon the surface of the liquid, and its value will be determined entirely by the weight of the piston.

It is convenient in engineering practice to refer all vaporization phenomena to some datum temperature, and since the melting point of ice, 32° F., is a convenient reference point, it is used as a standard datum temperature, in practically all steam-engineering work. Therefore, assuming the water in the jar to be at 32° F., if heat is applied the temperature of the liquid will rise approximately 1° F.

for every B.t.u. of heat added, since the specific heat of water is approximately unity.

Experiment shows that for each pressure under which the water may exist some definite temperature will be attained at which further rise of temperature will cease and the liquid will

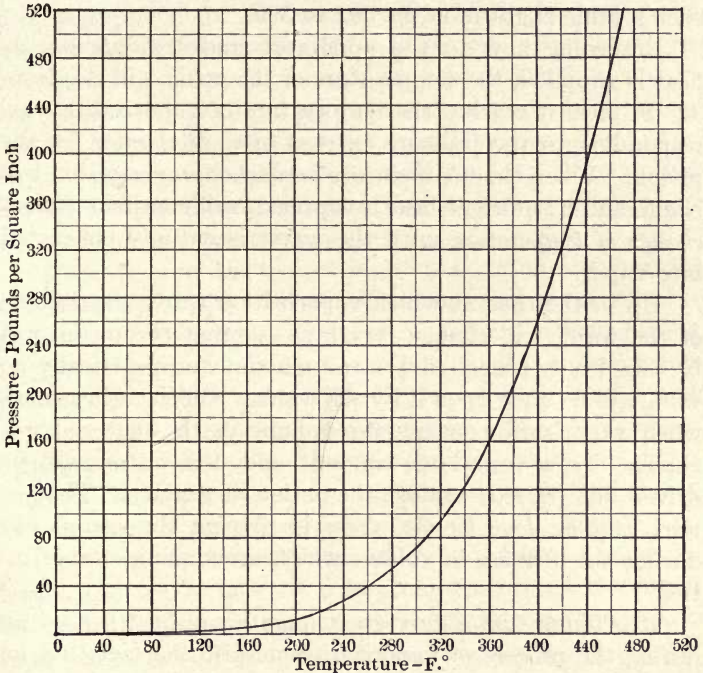

FIG. 12.—Pressure-Temperature Relations, Saturated Water Vapor.

begin to change to a vapor, that is, to vaporize. The temperatures at which vaporization occurs at different pressures are called the **temperatures of vaporization** at those pressures.

The temperatures of vaporization of water are plotted against pressure in Fig. 12. It should be noted that the values of vaporization temperature increase very rapidly for small pressure changes in the case of low pressures, but

that, for the higher pressures, the variation of temperature is very small for enormous variations of pressure. This fact is of great importance in steam engineering.

The temperatures of vaporization are tabulated with other properties of water vapor in so-called **steam tables** and are constantly referred to by engineers. An example of such a table is given on pp. 392 to 399.

Returning now to the apparatus under discussion, as heat is supplied, the temperature of the water will rise from 32° F. until it reaches the temperature of vaporization corresponding to the pressure exerted upon the water by the piston. When this temperature is reached vaporization will begin, and if sufficient heat is supplied, will continue *without change of temperature* until the water is entirely converted into vapor.

Up to the time at which vaporization starts the volume of the water will change very little, so that the piston will be raised only a negligibly small amount and practically no work will be done upon it by the water. On the other hand, when vaporization occurs the volume of the material will change by a very large amount and the piston will be driven out (raised) against the action of gravity. That is, *work will be done by the steam* in driving the piston out during the increase in volume which accompanies vaporization.

It is found that a very great quantity of heat is used up during the process of vaporization despite the fact that no temperature change occurs. This is described by saying that the heat which is supplied during this period becomes *latent* in the steam formed, and the quantity of heat is therefore spoken of as the **latent heat of vaporization**. It is assumed to consist of two parts, that used for separating the liquid molecules against their attractive forces and that used for doing the work which is done upon the piston as it is moved upward. The former is called the **internal latent heat** because it is used for doing internal or intermolecular

work; the latter is called **external latent heat** because it is used for the doing of external work.

It is to be noted that the internal latent heat may be assumed to be tied up in some way within the molecular structure of the material and hence to be *in the steam*. The external latent heat, on the other hand, is used up as fast as supplied for the purpose of driving the piston out against the action of gravity. When the piston has been raised to any point, the energy used in raising it is not *in the steam*, but is stored as potential energy *in the piston*. To get it back the piston must be allowed to drop. The term "external" is therefore well chosen; the external latent heat is in no sense *in the steam*; *it is stored in external bodies or mechanism*.

After the constant temperature vaporization is complete, the further addition of heat will again cause a rise of temperature and a gradual increase of volume. Such raising of the temperature of steam already formed is called **superheating** and results in carrying the vapor nearer and nearer to the condition in which it very nearly obeys the laws of ideal gases. Since an increase of volume accompanies superheating, the molecules of the vapor must move farther and farther apart as superheating progresses.

Vapor in the condition in which it is formed from the liquid and which has the same temperature as the liquid from which it was formed is called **saturated vapor**. This term can be pictured as meaning that the maximum number of molecules of vapor are packed into a given space; the addition of heat to saturated vapor would cause superheating and the separation of the molecules so that fewer could be contained in a given space.

20. Heat of Liquid, q or h . Returning once more to the start of the process described in the preceding section, heat was added to water initially at 32° F. until the temperature of vaporization corresponding to the existing pressure was attained. The heat added during this period is

called the **heat of the liquid**, and is usually designated by the letters q or h . If the mean specific heat of water at constant pressure (C_p) for the temperature range under consideration were constant, and equal to 1, then, since

$$q = C_p(t_v - 32)$$

in which t_v is the temperature of vaporization, it would follow that, for this pressure

$$q = t_v - 32 \dots \dots \dots (12)$$

Therefore, if water boils under a pressure of 50 lbs. at a temperature, read from the steam tables, of 281° F., it would follow that

$$q = 281 - 32 = 249 \text{ B.t.u.}$$

But the steam tables (see p. 394) for this pressure (50 lbs.) give $q = 250.1$ B.t.u., indicating, as was shown in Chap. I., that the specific heat of water does not remain constant, and for this case the mean value must have been approximately 1.004 as indicated by the following calculation.

$$q = C_p(t_v - 32) \text{ or } 250.1 = C_p \times 249$$

so that

$$C_p = \frac{250.1}{249} = 1.004 +$$

Hence it is always advisable to use the steam table values of q , except for very approximate calculations.

21. Latent Heat of Vaporization, r or L . The heat supplied during the period of vaporization has already been referred to as the latent heat of vaporization and has been divided into internal and external latent heats.

The internal latent heat is generally designated by ρ or by I and the external latent heat by the group of letters APu or by E . The group APu merely represents the prod-

uct of pressure, P , by volume change during vaporization, u , and by the fraction $\frac{1}{778}$ which is represented by A . The product of the first two terms gives external work in foot-pounds during vaporization, and dividing this by 778 (Joule's Equivalent) converts it to heat units to correspond with the other values. It should be noted that P in this expression stands for pressure in pounds per square foot.

The total latent heat of vaporization is generally designated by r or by L , and it follows from what has preceded that

$$r = \frac{J}{\rho} + APu. \quad (13)$$

The value of r for atmospheric pressure, that is, for a temperature of vaporization of 212° F., is very often used in engineering and should be memorized. Its value is now generally taken as 970.4 B.t.u., though recent work would seem to indicate a value of about 972 as nearer the truth.

22. Total Heat of Dry Saturated Steam, λ or H . The total heat required to convert a pound of water at 32° F. into a pound of saturated vapor at some temperature t_v is called the *total heat of the steam* or the heat above 32° and is designated by λ or by H . It is obviously the sum of the quantities which have just been considered, so that

$$\lambda = q + r = q + \rho + APu. \quad (14)$$

23. Total Heat of Wet Steam. In practical work the engineer seldom deals with pure saturated steam, the saturated vapor nearly always carrying in suspension more or less liquid water at its own temperature. To distinguish between saturated steam which carries liquid water and that which does not, the former is called **wet steam** or **wet saturated steam**, and the latter **dry saturated steam**.

The condition of dryness or wetness is described by what is known as the **quality** of the steam. Dry saturated steam is said to have a quality of 100 per cent while saturated steam carrying 10 per cent by weight of liquid is said to

have a quality of 90 per cent. Quality expressed as a decimal fraction is designated by the letter x , so that if x is said to be equal to 0.8 in referring to a certain sample of steam, it means that that steam sample consists of 80 per cent by weight of saturated steam and 20 per cent liquid at the same temperature.

Since the *water in wet steam has the same temperature as the steam*, it contains all the heat of the liquid which it would contain if it had been converted into steam, but it obviously contains no latent heat of vaporization. It follows that the *total heat in a pound of wet steam* (one pound of a mixture of saturated steam and water) with quality equal to x is

$$\text{Heat per pound} = q + xr = q + x\rho + xAPu. \quad (15)$$

The letter λ should never be used in designating the total heat per pound of wet steam, as it has been chosen as the symbol of the total heat per pound of dry, saturated steam.

24. Heat of Superheat. When the temperature of saturated steam is raised by the addition of more heat, that is, when it is superheated, a very definite quantity of heat is required. The quantity required per pound per degree would, by definition, be the specific heat of the material in question.

If the specific heat of superheated steam were reasonably constant, the heat required to raise its temperature at constant pressure from saturation temperature to some higher value t_2 would be given by the expression

$$\text{Heat required per pound} = C_p(t_2 - t_v)$$

but superheated steam, as handled by the engineer, is generally comparatively near the saturated condition, and under these circumstances the values of the specific heat vary rapidly with changes of pressure and temperature. The extent of these variations is shown in Fig. 13. It will be observed that for low pressures the specific heat is approxi-

mately constant at a value below 0.5 for any given pressure, but that for very high pressures it varies widely over a comparatively small temperature range. Thus at 600 lbs. per square inch the specific heat changes from unity at about 510° F. to 0.6 at about 550° F.

Practically, it is customary to use the type of equation just given and to substitute a *mean specific heat* over the required temperature range for the specific heat which cannot be assumed constant without too great an error. The

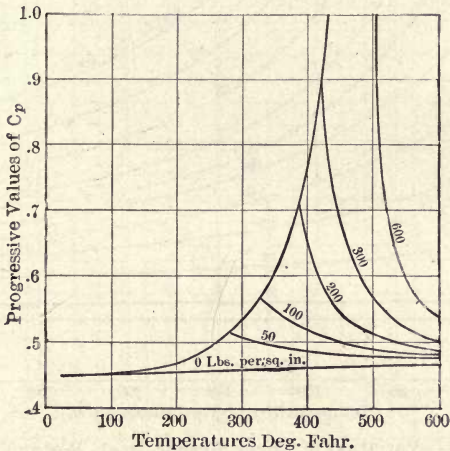

FIG. 13.—Progressive Values of Specific Heat, C_p , Water Vapor.

equation for heat required to raise the temperature from t_v to t_2 is then

$$\text{Heat of superheat per pound} = C_{pm}(t_2 - t_v). \quad (16)$$

in which C_{pm} stands for the mean specific heat at constant pressure over the temperature range from t_v to t_2 .

Values of mean specific heats of superheated steam are given in Fig. 14, the values indicated by the curves giving the mean specific heat between saturation temperatures and various higher temperatures at different pressures.

25. Total Heat of Superheated Steam. The total heat required to convert one pound of water at 32° F. into superheated steam at a temperature of t_2° F. under constant pressure conditions is obviously

$$\text{Total heat per pound} = q + r + C_{pm}(t_2 - t_v). \quad (17)$$

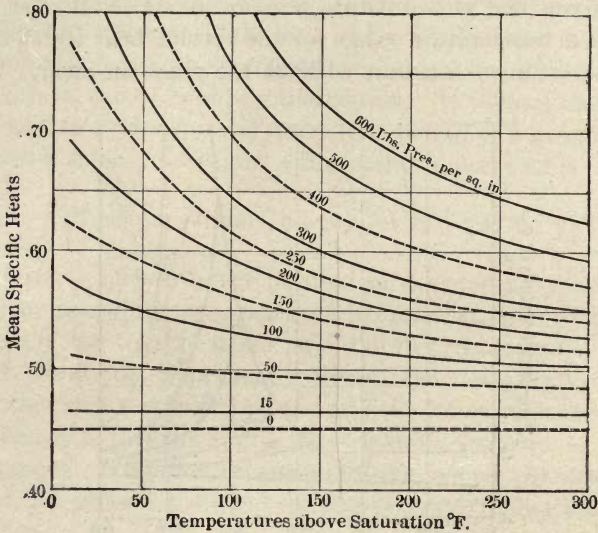

FIG. 14.—Variation of Mean Specific Heat, Water Vapor.

and representing the degrees of superheat ($t_2 - t_v$) by D , as is customary, this becomes

$$\text{Total heat per pound} = q + r + C_{pm}D. \quad (18)$$

26. Specific Volume of Dry Saturated Steam, V or S . The volume occupied by *one pound* of a substance is spoken of as the **specific volume** of that material. In the case of dry saturated steam there are as many specific volumes as there are pressures under which the steam can exist. These values are generally tabulated in steam tables and are represented by the letter V or the letter S .

The values of the specific volumes of steam at different pressures are given in Fig. 15. It is important to note the very gradual change of specific volume at high pressures and the very rapid change and enormous increase at low pressures. These facts have considerable influence on steam engineering practice.

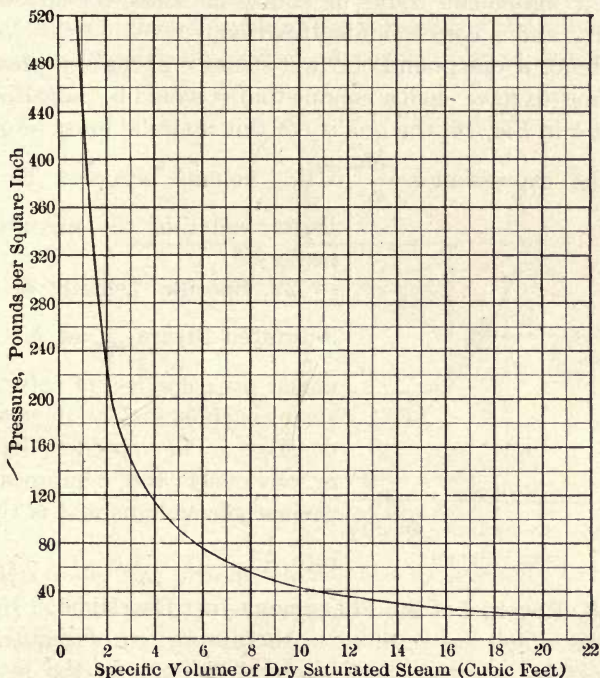

FIG. 15.—Pressure-Volume Relations, Saturated Water Vapor.

A curve giving properties of saturated steam is called a **saturation curve**, so that this name may be, and often is, applied to the curve given in Fig. 15.

The volume occupied at any pressure by half a pound of dry saturated steam will obviously be half that occupied by one pound of such material at the same pressure, and

the same statement can be made for any other fraction of a pound. It follows that if the small volume occupied by liquid water in wet steam be neglected, the volume occupied by one pound of steam (mixture) of 50 per cent quality can be assumed equal to half that occupied by an equal weight of dry saturated steam at the same pressure. A similar statement could of course be made for any other quality and a corresponding fraction.

Hence if one pound of "wet steam" at a given pressure is found to have such a volume that it would be indicated by point *b* in Fig. 16, the quality of this material must be given

by the expression $x = \frac{ab}{ac}$ if the volume occupied by the

liquid water in the mixture be neglected.

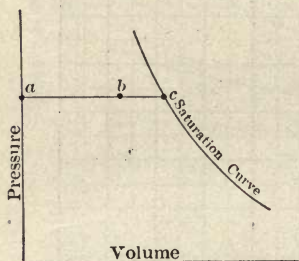

FIG. 16.—Determining Quality from Volume.

27. **Specific Density of Dry Saturated Steam, $\frac{1}{V}$ or δ .** The weight per cubic foot of saturated steam is spoken of as its specific density. The specific density is obviously the reciprocal of the specific volume and is therefore $\frac{1}{V}$.

28. **Reversal of the Phenomena Just Described.** If any process which has resulted in the absorption of a quantity of heat by a substance be carried through in the reverse direction, the same amount of heat will again be given up. It follows that a pound of dry saturated steam will give up the total latent heat of vaporization when condensed to liquid at the same temperature, and that the resultant pound of hot water will give up the total heat of the liquid if cooled to 32° F.

29. **Generation of Steam in Real Steam Boiler.** The steam boiler is equivalent to a vessel partly filled with water

and fitted with means for supplying heat to the water and for carrying off the vapor formed. This is shown diagrammatically in Fig. 17. At first glance this would not seem to be at all similar to the cylinder and piston already considered, but it really is the exact equivalent so far as the generation of steam is concerned. The flow of steam out of the steam-pipe is restricted to the extent necessary to maintain a high and constant pressure within the boiler, and, when in regular operation, steam is formed within the

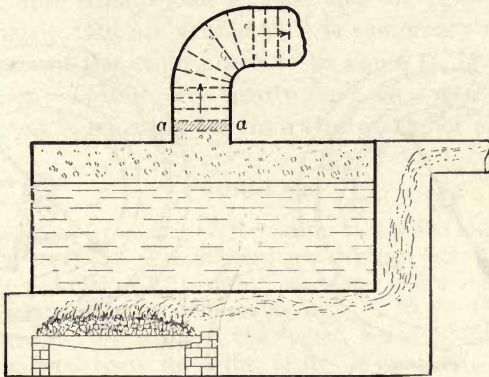

FIG. 17.—Formation of Steam in a Steam Boiler.

boiler under this pressure just as fast as necessary to replace that flowing out.

By picturing the steam as flowing out in layers or lamina these lamina can be imagined as taking the place of the piston in the apparatus of Fig. 11, and each pound of steam formed will then push a piston before it exactly as was assumed in the previous discussion.

30. Gauge Pressure. The steam pressure in a boiler is commonly determined by means of an instrument called a *pressure gauge*. These instruments are almost always constructed about as shown in Fig. 18 (a) and (b). The Bourdon spring is a tube of elliptical section bent approximately into

the arc of a circle. One end of this tube is connected directly to the pressure connection of the gauge and the other end is closed and connected to a toothed sector as shown.

When the pressure inside a tube of this character is increased, the tube has a tendency to unroll or straighten out, and in so doing it moves the toothed sector in such a way as to rotate the pointer or gauge hand and make its end move over the scale in the direction of increasing pressure. With diminishing pressure the tube again rolls up and rotates the hand in the opposite direction.

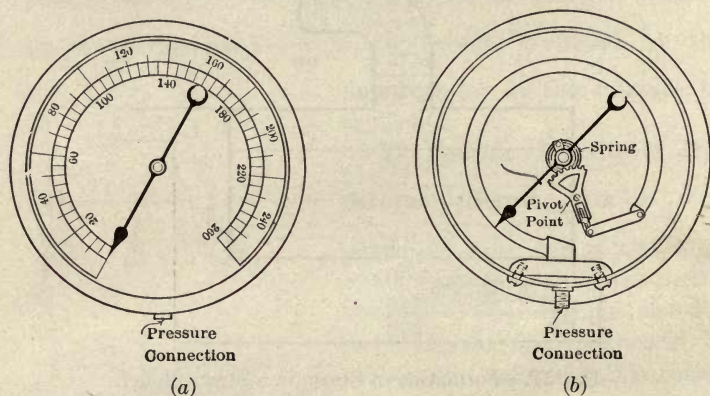

FIG. 18.—Bourdon Pressure Gauge.

Instruments of this kind are so made and adjusted that the hand points to zero when the gauge is left open to the atmosphere. Under such conditions the pressure inside the tube is equal to that of the atmosphere and is not zero. The gauge therefore only indicates pressures above atmospheric on its scale, and the total pressure inside the boiler is really that shown by the gauge plus that of the atmosphere.

Pressures as indicated by the gauge are called **gauge pressures**. Pressures obtained by adding the pressure of

the atmosphere to the reading of the gauge are known as **absolute pressures**. Then

$$\text{Absolute Pressure} = \text{Gauge Pressure} + \text{Atmospheric Pressure}$$

and

$$\text{Gauge Pressure} = \text{Absolute Pressure} - \text{Atmospheric Pressure.}$$

In accurate work the existing atmospheric pressure should be determined by means of the barometer, but for ordinary, approximate calculations and for cases in which no barometric data are available, it is customary to assume the pressure of the atmosphere to be equal to 14.7 lbs. per square inch. This is very nearly true, on the average, at sea level, but is generally far from true at higher elevations.

PROBLEMS

1. Determine by means of the steam tables the temperatures, total heats, heats of liquid, internal and external latent heats, and the specific volumes of 1 lb. of dry, saturated steam under the following absolute pressures (lbs. per sq. in.): 15, 50, 95, 180 and 400.

2. Determine the heats of the liquid, latent heats of vaporization and total heats for 2 lbs. of dry saturated steam at the following temperatures in °F.: 101.83, 212 and 327.8.

3. Determine the volumes occupied by 2 lbs. of dry saturated steam under the conditions of problem 2.

4. Determine the heats of the liquid, latent heats of vaporization and total heats for 1 lb. of saturated steam with a quality of 90% at the following absolute pressures: 25, 50, 75, 125.

5. Determine the total heat above 32° F. in 12 lbs. of saturated steam with quality of 97% at a pressure of 125 lbs. per square inch absolute.

6. What space will be filled by 20 lbs. of dry saturated steam at a pressure of 150 lbs. per square inch absolute?

7. What space will be filled by 20 lbs. of saturated steam at a pressure of 150 lbs. per square inch absolute and with a quality of 95% if the volume occupied by the water present be neglected?

8. How many pounds of dry saturated steam at a pressure of 75 lbs. per square inch absolute will be required to fill a space of 10 cu. ft.?

× 9. How many pounds of saturated steam with quality 96% and at a pressure of 110 lbs. per square inch absolute will be required to fill a space of 8 cu. ft.?

10. How much external work, measured in B.t.u., is done when 1 lb. of water at the temperature of 212° F. is converted into dry saturated vapor at the same temperature?

× 11. How much external work, measured in foot-pounds, is done when 2 lbs. of water at a temperature of 212° F. are converted into 90% quality steam at the same temperature?

12. How much heat is required for doing internal work during the vaporization of 1 lb. of water under such conditions that the total latent heat of vaporization is 852.7 B.t.u. and the external latent heat is 83.3 B.t.u.?

13. What is the quality of steam containing 1000 B.t.u. above 32° F. per pound when under a pressure of 150 lbs. per square inch absolute?

× 14. Heat is added to 1 lb. of mixed steam and water while the pressure is maintained constant at 100 lbs. per square inch absolute. The percentage of steam in the mixture is increased thereby from 50% to 95%.

(a) How much heat was added?

399.6

(b) How much internal latent heat was added?

362.9

(c) How much external latent heat was added?

36.63

15. How much heat is required to completely vaporize 1000 lbs. of water at a temperature of 92° F. when pumped into a boiler in which steam is generated at a pressure of 150 lbs. per square inch gauge? Note that heat above 32° F. in 92° F. water is given as q in steam tables for a temperature of 92° F. $1195 - 60 = 1135$ ft.

16. Find the amount of heat necessary to produce in a boiler 200 lbs. of steam having a quality of 97% at a pressure of 100 lbs. gauge when the feed water has a temperature of 205° F.

17. What volume would be occupied by the material leaving the boiler in problem 16, neglecting volume occupied by water?

CHAPTER IV

THE IDEAL STEAM ENGINE

31. The Engine. If the cylinder and piston assumed in the discussion of the last chapter be imagined as turned into a horizontal position and fitted with a frame, piston

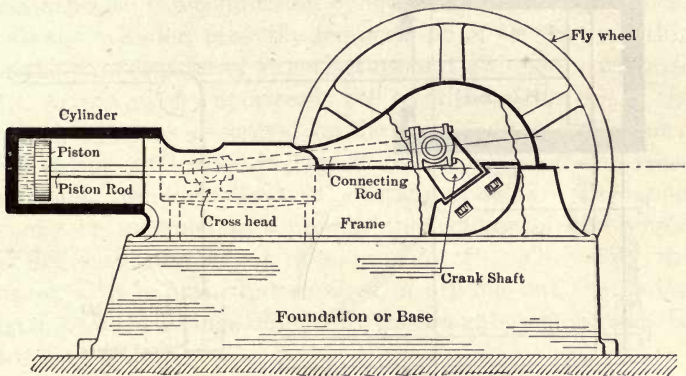

FIG. 19.—Simple Steam Engine.

rod, crosshead, connecting rod, crank shaft and flywheel as in Fig. 19, a device results which might be used as a steam engine for the production of power. By adding heat to, and taking heat from, the water and steam in the cylinder in the proper way and at the proper time, the water and steam, or working substance, can be made to do work upon the piston. The piston can transmit this work through the mechanism to the rim of the flywheel, and it can be taken from the rim by a belt connected to a pulley on a machine which is to be driven.

To make the analysis easier, a simplified type of engine will be assumed. It is shown in Fig. 20 and consists of the same cylinder, piston and piston rod as just described. A wire is fastened to the end of the piston rod and run back over a pulley in such a way that a weight fastened to the free end of the wire will be raised if the piston moves out. The weight is made up of two parts, one large and one small. When both are on the wire the pull which they exert causes the piston to exert a high pressure upon whatever is con-

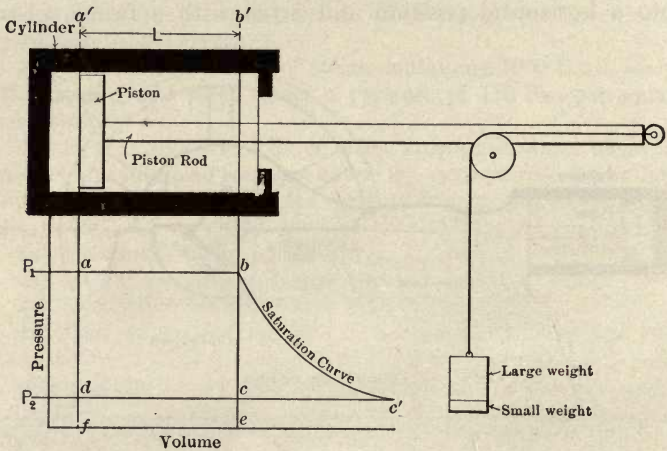

FIG. 20.—Simplified Steam Engine.

tained in the cylinder. When only the small weight hangs on the wire, the piston exerts a much lower pressure upon the material in the cylinder.

Imagine that the piston and the walls of the cylinder are made of some ideal material which will not receive or conduct heat. Imagine also that the cylinder is fitted with a permanent head which is a perfect conductor of heat. These conditions are of course ideal but are assumed for the sake of simplicity.

Assume further that, when one pound of water is con-

tained in the cylinder and the piston is driven into the cylinder by the two weights until the space between the piston and the cylinder head is just large enough to contain the pound of water, the piston exerts a high pressure equal to P_1 pounds per *square foot* against the water. The volume of this water and the pressure upon it can be represented by the point *a* of the *PV* diagram, Fig. 20.

32. Operation of the Engine. With conditions as described in the preceding paragraphs, imagine a flame or other source of heat at high temperature to be brought into contact with the conducting cylinder head and to pass heat into the cylinder, raise the temperature of the water within to the temperature of vaporization and ultimately vaporize it. As the water vaporizes it will push the piston out of the cylinder just as described in the last chapter and a horizontal line such as *ab* in Fig. 20 will represent the increase of volume (vaporization) at constant pressure. The point *b* may be assumed to represent the volume of one pound of dry saturated vapor at a pressure P_1 . Obviously the steam, as it is formed, does work in driving out the piston against the resistance offered by the weights which must be raised.

If a stop is provided which will prevent the movement of the piston beyond the position corresponding to the point *b*, it will be possible to remove the larger weight when that point is reached and the high pressure steam will hold the piston and rod hard against the stop. If now some cooling medium is applied, such as a large piece of ice held against the conducting head of the cylinder or water running over that head, heat will be abstracted and a partial condensation of the steam within the cylinder will occur. As condensation progresses the pressure will drop because there will be less and less steam, by weight, in a given volume. Such a process, would be indicated by the line *bc* which represents a drop of pressure, while the volume

contained within the cylinder walls between head and piston remains constant.

When some point c is reached, the steam pressure will have been reduced to a value equal to that exerted by the small weight, and the piston will be driven in toward the cylinder head while the heat absorbing medium continues to remove heat from the steam and to cause further condensation. The combination of piston motion and heat absorption will be so regulated that the pressure remains constant at P_2 during this process, because the weight will move the piston inward just as fast as necessary to maintain a constant pressure. If sufficient heat is absorbed, the pound of material within the cylinder will ultimately all be condensed or liquefied and will just fill the volume V_a .

The heat absorbing body may now be removed and an infinitesimal motion of the piston toward the head would serve to raise the pressure on the liquid water from P_2 to P_1 so that the volume V_a may be taken equal to the volume V_a and the line da may be assumed to be vertical. It would then represent an increase of pressure at constant volume. This might be caused by hanging a weight of the larger size on the wire when condition d was reached.

Having brought the material, or working substance, back to the conditions originally shown at a , the high temperature source of heat can again be brought in contact with the end of the cylinder and the entire cycle carried through once more. There is obviously no reason why it could not be repeated as often as desired.

33. Work Done by the Engine. If the device just described is to serve as a steam engine, it must actually make mechanical energy available, that is, it must convert into mechanical form some of the heat energy supplied it. It is now necessary to see whether it does so.

Water vaporizing and increasing in volume as from V_a to V_b was shown in the last chapter to do work upon the piston confining it. Work has been shown to be equal to

(total force \times total distance) and in this case if L represents the distance in feet traveled by the piston, the work done by the steam upon the piston while the latter moves from a' to b' must be

$$\begin{aligned} \text{Work done on piston} &= \text{total force} \times \text{distance} \\ &= P_1 \times \text{area of piston} \times L \dots \text{ft.-lbs.} \end{aligned}$$

But the product of area of piston in square feet by distance traveled in feet is equal to the piston displacement or volume swept through by the piston, that is $(V_b - V_a)$ cubic feet. Therefore

$$\text{Work done on piston} = P_1(V_b - V_a) \text{ ft.-lbs.} \quad (19a)$$

$$= \frac{P_1(V_b - V_a)}{778} \text{ B.t.u.} \quad (19b)$$

The first form of this expression $P_1(V_b - V_a)$ is very obviously represented by the area under the line ab in Fig. 20 and this area therefore represents the work done by the steam upon the piston during the change of volume at constant pressure represented by that line. While the steam is supplying this amount of energy to the piston or doing this amount of work upon the piston, the latter does an equivalent amount of work upon the weights if frictionless mechanism be assumed. In such a case the total weight hung on the wire multiplied by the distance raised would therefore give the same result in foot-pounds as that just obtained.

It should be noted that Eq. (19) is merely an expression of the external work done during vaporization, that is, an expression of the amount of heat which is used for the doing of external work. It is the exact equivalent of the external latent heat previously discussed. In fact, the group of symbols APu is really a condensation of Eq. (19) formed by putting A for $\frac{1}{778}$ and u for $(V_b - V_a)$.

The line cd also represents a change of volume at constant pressure and the same type of formula as applied to ab will express the work done during this process. In this case, however, the piston is being pushed into the cylinder by the small weight against the pressure of the steam, and energy is being supplied to push the piston in. This energy is equal to the weight of the small weight (pounds) multiplied by the distance it falls (feet). The piston is therefore doing work upon the steam, and the amount is

$$\text{Work done on steam} = P_2(V_c - V_d) \text{ ft.-lbs.} \quad . \quad . \quad (20)$$

$$= \frac{P_2(V_c - V_d)}{778} \text{ B.t.u.} \quad . \quad . \quad (21)$$

The first form of expression also represents the area under the line cd and this area therefore represents the work done by the piston upon the steam mixture in the cylinder during the process represented by cd .

No work can be done by steam on piston or by piston on steam during the processes represented by bc or da because both the weights and the piston are stationary during these changes and it has already been shown that work involves motion.

The total work done upon the piston by the steam is therefore represented by the area $abef$ and this amount of energy is used in raising the two weights through a vertical distance equal to the piston travel. Some of this energy, or its equivalent, will have to be returned an instant later, however, in order that the piston may do the work shown by the area $cdfe$ upon the steam. It is returned by the small weight dropping through a distance equal to the travel of the piston. The net mechanical energy made available by carrying through the series of processes is therefore represented by the area $(abcf) - (cdfe) = (abcd)$ or the area enclosed by the four lines representing the

pressure and volume changes experienced by the working substance during one cycle of events. It is equal to the work done in raising the larger weight a vertical distance equal to the travel of the piston.

This net energy made available is obviously

$$\begin{aligned} \text{Energy made available} &= P_1(V_b - V_a) - P_2(V_c - V_a) \\ &= (P_1 - P_2)(V_b - V_a) \text{ ft.-lbs.} \quad (22) \end{aligned}$$

$$= \frac{(P_1 - P_2)(V_b - V_a)}{778} \text{ B.t.u.} \quad (23)$$

Since this amount of energy is made available while one cycle of events is being carried out and since the cycle can be repeated time after time if sufficient heating and cooling mediums are available, any quantity of mechanical energy can be produced from heat energy by repeating the cycle a sufficient number of times. This would correspond to picking up a number of the larger weights which were slid on to the wire at the lower elevation and slid off at the higher.

This repetition of cycles would correspond, in a real engine, to running at such a speed that the required number of cycles would be produced in a given time to make available the amount of mechanical energy required.

Or, the power made available per cycle could be increased. This is easily seen by an inspection of Eq. (22). Increasing the value of either of the right-hand terms will obviously increase the amount of energy made available. The value of $(P_1 - P_2)$ can be increased by raising the initial pressure P_1 or by lowering the final pressure P_2 . The value of $(V_b - V_a)$ may be increased by using more than one pound of material, thus increasing both the volume V_b of the saturated steam formed and increasing the volume V_a of the liquid water, but getting a greater numerical value for $(V_b - V_a)$. This would correspond in a real case to using a larger cylinder and therefore a larger engine.

ILLUSTRATIVE PROBLEM

An engine of the type described is to work with a maximum pressure of 100 lbs. per square inch absolute and a minimum pressure of 15 lbs. per square inch absolute. The cylinder is to be of such size that 1 lb. of water is used and the steam is to be dry and saturated at the point *b* of the cycle.

Find: (a) the amount of mechanical energy made available per cycle; (b) the amount of energy made available per minute if 150 cycles are produced per minute; and (c) the horse power of the engine.

It will first be necessary to find the piston displacement required and the space necessary between piston and cylinder head to accommodate the pound of water in liquid form. The steam tables give the volume of one pound of dry saturated steam at 100 lbs. per square inch as 4.429 cu.ft. and the volume of one pound of water may be taken as 0.017 cu.ft. The values of the various volumes and pressures will therefore be

$$V_a = V_d = 0.017 \text{ cu.ft.};$$

$$V_b = V_c = 4.429 \text{ cu.ft.};$$

$$P_a = P_b = 100 \times 144 = 14,400 \text{ lbs. per sq.ft.};$$

$$P_c = P_d = 15 \times 144 = 2160 \text{ lbs. per sq.ft.}$$

(a) Using Eq. (22) the amount of mechanical energy made available per cycle will be

$$\begin{aligned} (P_1 - P_2)(V_b - V_a) &= (14,400 - 2160)(4.429 - 0.017) \\ &= 12,240 \times 4.412; \\ &= 54,002.88 \text{ ft.lbs.} \end{aligned}$$

(b) If 150 cycles are produced per minute, the total amount of mechanical energy made available per minute must be

$$150 \times 54,002.88 = 8,100,300 \text{ ft.-lbs.}$$

(c) The horse power must then be

$$\text{h.p.} = \frac{8,100,300}{33,000} = 245 +.$$

34. Heat Quantities Involved. It is a very simple matter to determine the quantity of heat which must be supplied to produce the process *ab*, and the quantities of

heat which must be removed to produce the processes bc and cd . This can be done by making use of the known properties of water and steam as given in the steam tables.

The water at d must be at the temperature of vaporization corresponding to pressure P_2 since it has just been formed by condensation from steam under that pressure. It therefore contains the heat of the liquid corresponding to that pressure. If it is to be vaporized at pressure P_1 , it must first be raised to the higher temperature corresponding to that pressure. The amount of heat required to do this will obviously be the difference between the heat of the liquid at the temperature corresponding to P_1 and the heat of the liquid at the temperature corresponding to P_2 . These can be found in the steam tables.

The latent heat of vaporization at P_1 must then be added to cause the increase of volume shown by ab . This can also be found in the steam tables for any given case.

The quantity of heat which must be removed to produce the processes represented by bc and cd can be found similarly from steam table values, although the exact method of procedure is not quite as obvious as in the preceding cases.

Assuming that it is possible to find the heat supplied, Q_1 , and the heat removed, Q_2 , it is obvious that the energy made available in mechanical form, per cycle, must be equal to $(Q_1 - Q_2)$ B.t.u., since this is the amount of heat energy which has disappeared and since it cannot have been destroyed. This may be put in the form of an equation, thus

$$\text{Energy made available} = Q_1 - Q_2. \quad \dots \quad (24)$$

If the proper substitutions are made in this formula and it is then simplified, it becomes

$$\text{Energy made available} = (APu)_{P_1} - x_c(APu)_{P_2} \text{ B.t.u.}, \quad (25)$$

in which

$(APu)_{P_1}$ = the external latent heat at pressure P_1 ;
 $(APu)_{P_2}$ = the external latent heat at pressure P_2 , and
 x_c = quality at point c , which can be found from
 the ratio of dc to dc' .

Numerical substitution in this equation for any given case will show that it gives exactly the same values as would be obtained by the use of Eq. (23).

It is to be noted particularly that the energy made available is actually less than the *external* latent heat at the higher pressure, while the heat supplied must be equal to the *total* latent heat plus some of the heat of the liquid. An inspection of the steam tables will show that the external latent heat for ordinary steam pressures forms a very small fraction of even the total latent heat, and therefore the mechanical energy made available for a given expenditure of heat energy is very small in the case under discussion.

35. Efficiency. The term efficiency is used in engineering as a measure of the return obtained for a given expenditure. It may be defined in any one of the following ways:

$$\begin{aligned} \text{Efficiency} &= \frac{\text{Useful result}}{\text{Expenditure made to obtain that result}} \\ &= \frac{\text{Result}}{\text{Effort}} \\ &= \frac{\text{Output}}{\text{Input}} \dots \dots \dots (26) \end{aligned}$$

In the case of a heat engine, the useful result is the mechanical energy obtained by the operation of the engine, while the expenditure made is the heat which is supplied. For this case efficiency may therefore be defined by the expression

$$\text{Engine efficiency} = \frac{\text{Mechanical energy obtained per cycle}}{\text{Heat supplied per cycle}}$$

$$= \frac{E}{Q_1} \dots \dots \dots (27)$$

$$= \frac{Q_1 - Q_2}{Q_1} \dots \dots \dots (28)$$

in which

E stands for mechanical energy obtained,
 Q_1 stands for heat supplied, and
 Q_2 stands for heat rejected.

In the case of the type of steam engine just considered, this efficiency would have a value between 6 and 8 per cent for ordinary pressures. That is, the engine would produce in mechanical form only 6 to 8 per cent of the energy supplied it in the form of high temperature heat. Moreover, these figures would hold only for a theoretically perfect engine; a real engine built to operate upon this cycle would probably give efficiencies of the order of 2 to 3 per cent. The reasons for this great discrepancy will be discussed in a later chapter.

36. Effect of Wet Steam. In what has preceded, it was assumed that the pound of steam was completely vaporized along the line ab so that dry, saturated steam existed in the cylinder at b . It might, however, be assumed that vaporization was incomplete at the upper right-hand corner of the cycle, so that this point occurred at a point to the left of b and with a quality x at that point less than unity.

Under such conditions, the cylinder would not have to be so big, since the maximum volume attained by the steam would be smaller than in the preceding case. The work done per cycle would obviously be smaller in quantity, because the area enclosed within the lines of the cycle would be smaller. It can also be shown that the efficiency would also be lowered by lowering the quality at b .

37. Application to a Real Engine. The engine which has been described in the preceding paragraphs could easily be converted into the counterpart of a real engine by substituting connecting rod, crank shaft and flywheel for wire, pulley and weights as described in the first paragraph of this chapter. It could then be made to do work in just the same way as has been described; some of the energy made available during the outstroke would be used for overcoming resistance at the shaft, that is, doing useful work, and some of it would be stored in the flywheel which would speed up slightly. The energy which must be expended on the steam during the return stroke would be obtained by allowing the flywheel to slow down and thus deliver sufficient kinetic energy to drive the piston back against the low-pressure steam. The cycle and the efficiency would thus, theoretically, be exactly the same as those just investigated.

Great difficulty would, however, be met in a real engine if the steam had to be formed and condensed within the cylinder, and another method which gives the same results is therefore used. Steam is generated in a boiler and allowed to flow into the cylinder and push out the piston just as though it were actually being formed in the cylinder as previously described. When the piston reaches the end of its outstroke the inlet valve is closed and the exhaust valve is opened, allowing some of the steam to blow out into a space in which a lower pressure exists. As the piston stands still at the end of its stroke while the pressure drops, the line *bc* is produced as in the previous description, but by a different method. The piston then returns and drives the remaining steam out of the cylinder at a constant pressure theoretically equal to that of the space into which the steam is being forced or exhausted. The line *cd* is thus produced and the closure of the exhaust valve and opening of the admission valve when *d* is reached will start the cycle over again.

In order to get more work out of a given size of cylinder and to obviate the necessity of giving back energy which has already been given out, engines are generally made to take steam on both sides of the piston. They are then known as **double acting engines**. In this case the steam admitted on one side of the piston would supply the energy necessary both for overcoming the resistance due to the load and for driving out the low-pressure steam on the other side of the piston. On the return stroke conditions would be just reversed.

38. Desirability of Other Cycles. The cycle of operations described in preceding paragraphs is the most inefficient of all those actually used, that is, it gives the smallest return for a given amount of heat supplied. This is because only the external latent heat supplied is converted into mechanical energy and part of that energy must be returned to complete the cycle. All of the internal latent heat and all of the heat of the liquid supplied along *ab* pass through the engine without conversion and are exhausted.

Therefore, cycles which differ from that described in such a way as to make it possible to convert into mechanical energy some of the internal latent heat and possibly some of the heat of the liquid should be highly desirable as they ought to yield a larger return of mechanical energy for the same total amount of heat supplied. Two such cycles are commonly used; they may be described as the *Complete-expansion cycle* and the *Incomplete-expansion cycle*. The former is used in steam turbines, the latter in most reciprocating steam engines. The rectangular cycle which has just been described is used in duplex pumps and similar apparatus.

39. The Complete-expansion Cycle. This cycle, which is also known as the Clausius and as the Rankine cycle, starts just the same as that already described. This is shown in Fig. 21. The pressure on, say, a pound of water

is raised from P_2 to P_1 and its temperature is raised from that of vaporization at P_2 to that of vaporization at P_1 . After this it is vaporized, giving the increase of volume

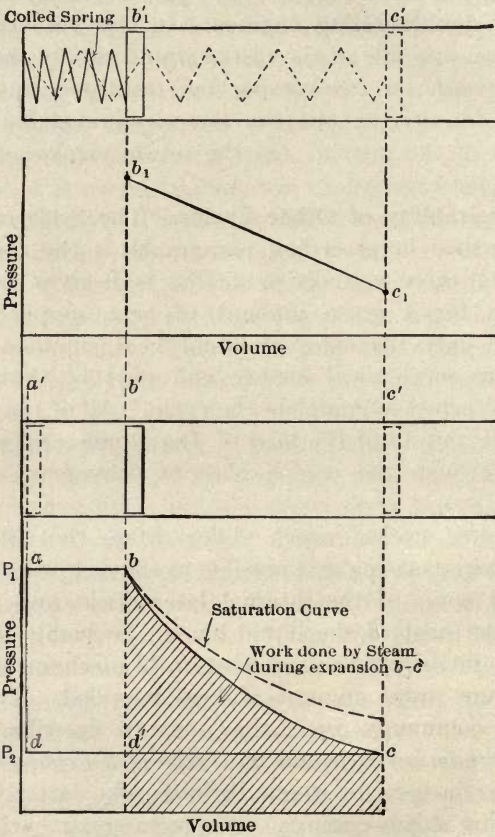

FIG. 21.—Complete Expansion Cycle or Clausius Cycle.

shown by ab . The supply of heat is then stopped. The cylinder of the engine is made larger than in the preceding type so that when the point b' is reached the piston can travel still further, and it is allowed to do so, that is, the

high-pressure steam is allowed to push it further out. This can be pictured by imagining the steam to act like the compressed spring shown in the figure and to push the piston in much the same way as does the spring. The line b_1c_1 shows the decreasing pressure exerted on the piston by the spring as the latter expands so as to get longer and longer. Because of the properties of a spring this is a straight line. The line bc shows the decreasing pressure exerted on the piston by the steam as the latter expands so as to occupy greater and greater volumes. Because of the properties of steam this line is curved instead of straight.

Work will be done on the piston by the expanding steam during the process bc and the amount of this work will be indicated by the area under the line bc as shown in the figure. This work must have been done by the expenditure of energy on the part of the steam and since no energy was added after the point b was reached the work must have been done at the expense of heat energy contained in the steam at b . It has already been shown that the heat above 32° in the steam at b is equal to the sum of the heat of the liquid and the internal latent heat, and some of this heat must obviously be used for the doing of work along bc instead of being entirely rejected to the cooling medium as in the preceding cycle without "expansion."

The expansion of the steam continues until the "back pressure" P_2 is reached. The cooling medium may then be imagined to be brought into use and to abstract such heat of vaporization as may remain in the steam besides absorbing the equivalent of the work done on the steam by the returning piston, thus giving the process shown by the line cd .

If the expansion line bc of the cycle just described could be carried out within walls constructed of such material that it would not give heat to nor take heat from the steam, it is obvious that any heat energy lost by the steam during the expansion could be lost only by conver-

sion into mechanical energy. An expansion of this kind is called an **adiabatic expansion**.

In the figure, the curve of adiabatic expansion is shown in its correct position with respect to the saturation curve and it is obvious that *for an adiabatic expansion, starting with dry, saturated steam, the quality decreases as the expansion progresses.*

Comparison with Cycle without Expansion. The heat supplied is the same in both of the cycles just considered when they operate between the same two pressures, but the mechanical energy obtained in the case of the complete expansion cycle is much greater. In Fig. 21, for instance, the mechanical energy obtainable with the cycle first described is represented by the area $abd'd$ while that obtainable with the complete expansion cycle with the same heat supply Q_1 is represented by the same area $abd'd$ plus the additional area bcd' . The efficiency of the complete expansion cycle is therefore very much higher than that of the cycle without expansion.

For conditions similar to those giving a theoretical efficiency of about 6 per cent without expansion, the complete expansion cycle will give a theoretical efficiency of about 12 per cent and this figure can be doubled by expedients which will be considered later.

The cylinder required for the production of the complete expansion cycle would be much larger than that required for the other cycle if both used the same weight of steam per cycle. The proportion would be in the ratio of the volume shown at c in Fig. 21 to the volume shown at b . But the complete expansion cycle would make available much more energy per pound of steam than would the other, so that the difference in the size of cylinders would not be so great if both were required to make available the same amount of mechanical energy per cycle.

40. The Incomplete-expansion Cycle. The shape of this cycle is shown in Fig. 22. It is just like the complete

expansion cycle down to the point c . The cylinder in which it is produced has a smaller volume than that used for the complete expansion cycle so that the piston arrives at the end of its stroke before it

has opened up volume enough to enable the steam to expand all the way down to the lowest pressure (terminal or back pressure). When the point c is reached in the real engine, the exhaust valve is opened and enough steam then blows out to

reduce the pressure to the back pressure P_d . The piston then returns and drives out the remainder of the steam as shown by the line de .

In the ideal method assumed in the preceding treatment, the heat absorbing medium would be brought into use at c , absorbing sufficient heat to reduce the pressure from P_c to P_d while the piston remained stationary at the end of its stroke. The latent heat of vaporization remaining in the steam at d would then be absorbed as the piston was driven back from d to e .

Comparison with Other Cycles. The incomplete expansion cycle is intermediate between the two previously discussed. This can be appreciated readily by an inspection of Fig. 22. In this figure the area $abd'e$ represents the mechanical energy obtainable with the cycle without expansion; the area $abc'e$ represents the energy obtainable from the same quantity of steam with complete expansion; and the area $abcde$ represents the energy obtainable from the same amount of steam with incomplete expansion.

The later the point at which the exhaust valve is opened, point c , the more nearly do efficiency and energy obtainable approach the values for the complete expansion cycle.

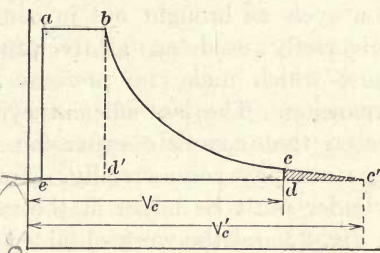

FIG. 22.—Incomplete Expansion Cycle.

The earlier the point at which the exhaust valve is opened, the more nearly do efficiency and energy obtainable approach the values for no expansion.

Despite the lower efficiency of the incomplete expansion cycle as brought out in connection with Fig. 22 it is universally used on all reciprocating engines excepting those which make no pretense to economy and use no expansion. The less efficient cycle is used for the simple reason that complete expansion in a reciprocating engine does not pay commercially. For complete expansion the cylinder must be larger in the ratio of V_c to V_c' as shown in Fig. 22 and the work obtained by completing the expansion is a very small part of the total. In most cases it would not be great enough to overcome the friction of the engine, not to mention paying interest on the necessarily higher cost of the larger cylinder and accompanying parts.

It will be shown in a later chapter that the steam turbine can economically expand the steam completely and the complete expansion cycle is therefore used with such prime movers.

CHAPTER V

ENTROPY DIAGRAM

41. Definitions. In Chapter III temperature, pressure and volume were discussed as criteria determining the condition of water and steam. Other things may be used in determining the condition of such materials. One which is particularly useful from an engineering standpoint is known as *entropy* and is designated by the Greek letter ϕ .

For every condition of water and steam, there is a characteristic value of entropy just as there is a characteristic value of temperature, pressure, volume, heat above 32° F., etc. These values of entropy are given in the steam tables in just the same way as the value of temperature, pressure, volume, heat above 32° F., and such, are given.

The entropy of the liquid given for any particular pressure is the change of entropy experienced by one pound of the liquid when its temperature is raised from 32° F. to the temperature of vaporization corresponding to that particular pressure. It might be spoken of as the entropy of the liquid above 32° F., just as q is spoken of as the heat of the liquid above 32° F. It is represented by ϕ_l .

The entropy of vaporization given for any particular pressure is the change of entropy experienced by one pound of the material while changing from water at the temperature of vaporization to dry saturated steam at constant pressure. It corresponds to the latent heat of vaporization and is designated by ϕ_v .

The entropy of dry saturated steam at any pressure is the sum of ϕ_l and ϕ_v and therefore is the total change of entropy experienced by a pound of material in changing

from water at 32° F. to dry saturated steam at the particular pressure in question.

The entropy of superheat at any pressure and temperature is the change of entropy experienced by a pound of dry, saturated steam at that pressure when superheated to that particular temperature. It is designated by ϕ_s .

The entropy of superheated steam at any pressure and temperature is the total change of entropy experienced by one pound of material when changed from water at 32° F.

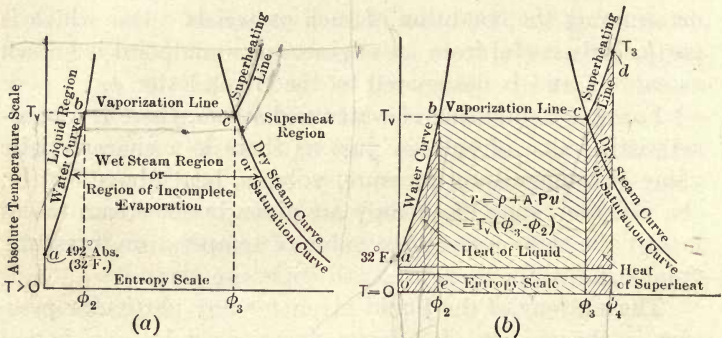

FIG. 23.—Temperature-Entropy Diagrams.

to superheated steam at the pressure and temperature in question. It is equal to $\phi_i + \phi_v + \phi_s$.

42. Temperature-Entropy Chart for Steam. Entropy is particularly useful to the engineer because it enables him to draw charts which lend themselves readily to an easy, graphical solution of certain problems which would otherwise involve complex calculations. One of these charts is known as the *Temperature-Entropy Chart*.

In making this chart, absolute temperature is generally plotted on the vertical and entropy above some datum temperature on the horizontal, as shown in Fig. 23 (a) and (b), which represents the construction of a temperature entropy diagram for water and steam. The entropy values on

this chart are plotted above 32° F. as datum temperature.

The water line or water curve is obtained by picking out of the steam tables the values of ϕ_l , entropy of the liquid, for different pressures and plotting them against the absolute temperatures corresponding to those pressures. Obviously, zero of entropy will occur at the absolute temperature corresponding to 32° F., i.e., about 492° F. abs.

The saturation curve or **dry steam curve** is obtained by picking out of the steam tables the values of $\phi_l + \phi_v$ for different pressures and plotting against corresponding absolute temperatures.

The entropy of vaporization is obviously shown for each different temperature (or pressure) by the distance between the water curve and the saturation curve, since the former is distant from the vertical axis by an amount equal to ϕ_l , while the latter is distant an amount equal to $\phi_l + \phi_v$.

Superheating lines are drawn by picking from the steam tables the values of entropy above 32° F. for steam superheated to different temperatures at one particular pressure and plotting against the proper temperatures. There will be as many superheating lines on the diagram as one chooses pressures for which to plot them. Only one is shown in the figure.

One very useful property of this diagram follows from the fact that points on its surface indicate the condition of the material. For instance, if the temperature-entropy, or $T-\phi$, values of the material at a given condition should plot to the left of the liquid line, the material must be in the liquid condition; if they plot between the liquid line and the saturation curve, the material must be a mixture of liquid and saturated vapor; if they plot on the saturation curve, the material must be dry, saturated steam; and if they plot to the right of the saturation curve, the material must be superheated steam. This all follows directly from the definition of entropy above 32° F., as plotted in these dia-

grams. The various regions, or fields, into which the diagram divides in this way are shown in Fig. 23 (*a*).

Another very useful property of this diagram follows from the fact that area represents heat just as area on a pressure-volume diagram was found to represent work. Thus the area under the line *ab*, for instance, represents the heat required to raise the temperature of one pound of water from 32° F. to the temperature at *b*. Similarly the area under the line *bc* represents the heat required to change a pound of water at the temperature at *b* to a pound of dry, saturated steam at the same temperature. The heat required to superheat this pound of saturated steam at constant pressure up to the temperature shown at *d* is similarly represented by the area under the line *cd*.

In this connection, it should be noted that this diagram is plotted above absolute zero of temperature just as the pressure-volume diagram is plotted above absolute zero of pressure. The areas in question therefore extend down to the absolute zero of temperature. In order to indicate this in Fig. 23 (*b*), a large part of the chart is supposed to have been broken out, so that the lower end of the diagram could be moved up into view. In Fig. 23 (*a*), the bottom of the diagram is drawn a few degrees below 32° F. and this is indicated by putting $T > 0$ opposite the horizontal axis.

The various areas hatched in Fig. 23 (*b*) indicate the various quantities of heat previously discussed. It should be understood that the areas represent the heat quantities only for the particular pressure which corresponds to the temperature indicated by T_v . For a higher pressure, the line *bc* would be higher and the areas proportionately larger; for a lower pressure the line *bc* would be lower and the areas smaller.

ILLUSTRATIVE PROBLEM

Starting with liquid at a temperature T_1 corresponding to the temperature of vaporization at a pressure of 50 lbs. per square inch absolute, assume the liquid raised to the temperature of vaporization at a pressure of 100 lbs. per square inch absolute and then completely vaporized. Determine the various changes of entropy and indicate them on a $T\phi$ -chart.

The steam tables give entropy of the liquid, ϕ_l , as equal to 0.4113 for water about to vaporize under 50 lbs. per sq. in. absolute, and 0.4743 for water about to vaporize under a pressure of 100 lbs. per sq. in. absolute. The difference, that is, $0.4743 - 0.4113 = 0.0630$, must be the entropy change experienced by the liquid when its temperature is raised from the lower to the higher value. These values are shown in Fig. 24.

The steam tables give entropy of vaporization, ϕ_v , at 100 lbs. per square inch absolute as 1.1277. Adding this to the entropy above 32° F. of the liquid at vaporization temperature under 100 lbs. pressure gives $0.4743 + 1.1277 = 1.602$ as the entropy above 32° of dry, saturated steam at 100 lbs. per square inch absolute. These values are all indicated in their proper position in Fig. 24.

The total change of entropy experienced by the material in changing from water at the temperature of vaporization under 50 lbs. pressure to dry, saturated steam at 100 lbs. pressure is obviously equal to $0.0630 + 1.1277 = 1.1907$.

43. Quality from $T\phi$ -chart. The entropy change experienced by steam in the process of vaporization is directly proportional to the addition of heat. Thus, when half the latent heat has been added to one pound of material, the entropy change is $\frac{1}{2}\phi_v$. In general, if a fraction x of the latent heat has been added, the entropy change has been $x\phi_v$ during the process. Therefore, if the temperature entropy condition of a pound of material should plot at a

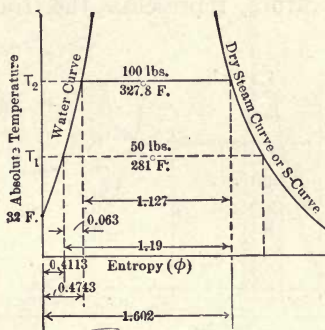

FIG. 24.

point such as c in Fig. 25, it follows that the material is a mixture of water and steam and that a fraction of the pound equal to $\frac{bc}{bd}$ is steam, the rest being water. But, by definition, the fraction $\frac{bc}{bd}$ is x , the quality of the material.

The temperature-entropy chart is very useful when used in connection with this property of showing quality. Thus, in Fig. 25, the area under bc , down to absolute zero temperature, represents the fraction of the latent heat of

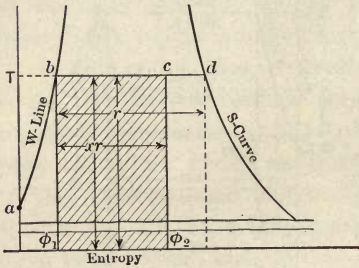

FIG. 25.—Quality from Temperature-Entropy Chart.

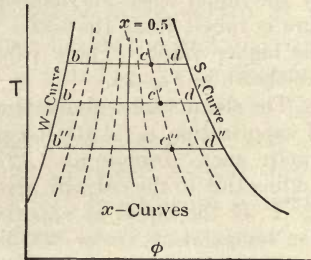

FIG. 26.—Constant Quality Curves.

vaporization per pound which must be added to give a pound the quality x .

For convenience in use, **constant quality lines** are generally drawn on temperature-entropy charts. Such lines are shown in Fig. 26. Each line is obtained by plotting the temperature entropy conditions for a given quality at different pressures. For this purpose, ϕ_v and ϕ_l are taken from the steam tables for a given pressure. The numerical value of ϕ_v is then multiplied by the fraction representing the chosen quality, say 0.9, and the product is added to ϕ_l , giving the total entropy above 32° F. for quality 0.9 at the particular pressure chosen. The same

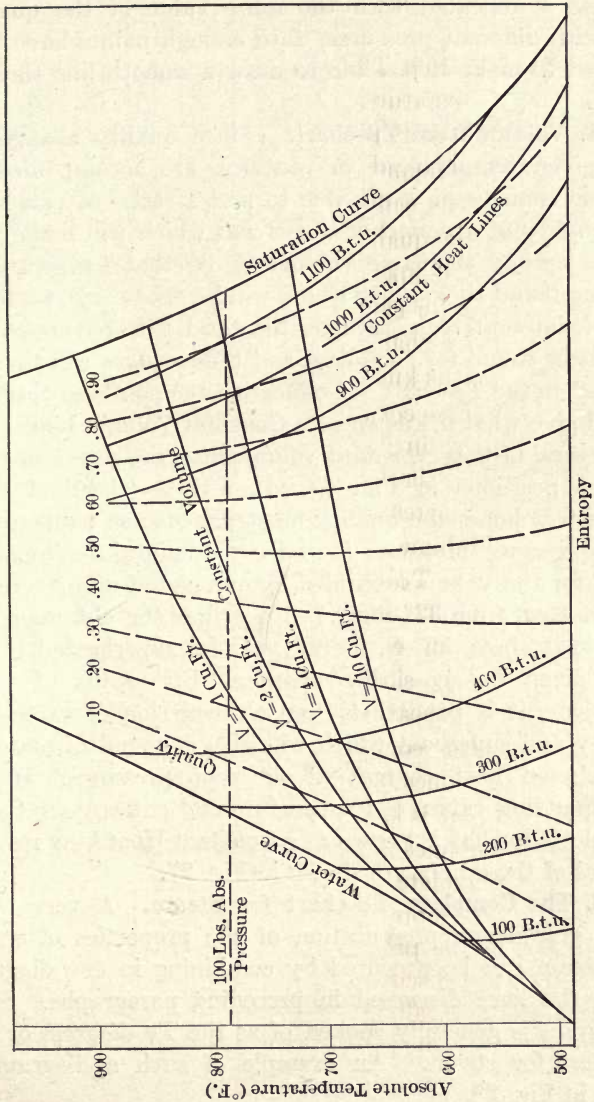

Fig. 27.—Constant Volume, Constant Quality, and Constant Heat Lines.

process is repeated with the same value of the quality, but with different pressures, until enough points have been secured to make it possible to draw a smooth line through them.

44. Volume from $T\phi$ -chart. Since quality changes at any given temperature, or pressure, are accompanied by volume changes, it is possible to find a series of values for the quality of a pound of wet steam which will make that pound occupy the same volume at different temperatures. Having found the quality which will be necessary at a number of different temperatures, the total entropy above 32° F. can be found for each case and these values can then be plotted on the $T\phi$ -chart. Connecting the points so obtained would give what is known as a **Constant Volume Line**.

Several of these constant volume lines are shown in their correct positions in Fig. 27. It will be observed that, for each volume, the quality must increase as temperature (and pressure) increases in order to maintain a constant value for the volume occupied by one pound of mixture.

45. Heat from $T\phi$ -chart. Equations for obtaining the total heat above 32° F. for wet and for superheated steam were given in an earlier chapter. By means of these equations, it is possible to find a succession of values for quality and superheat which will give a pound of material any chosen heat content at different pressures. If the corresponding values of temperature and entropy are found and plotted, what is known as a **Constant Heat Line** results. Several of these lines are shown in Fig. 27.

46. The Complete $T\phi$ -chart for Steam. A very complete, graphical representation of the properties of water and steam can be procured by combining in one diagram all of the lines discussed in preceding paragraphs. Such a diagram is generally spoken of as the *$T\phi$ -diagram* or the *$T\phi$ -chart* for steam. An example of such a diagram is given in Fig. 28.

This chart is very useful, as it enables one to solve by

TEMPERATURE-ENTROPY DIAGRAM

TO ACCOMPANY

STEAM POWER

C. F. HIRSHFELD AND T. C. ULBRICHT,

(Published by John Wiley & Sons)

Redrawn (with permission) from larger diagram in Peabody's Steam and Entropy Tables (Wiley & Sons)

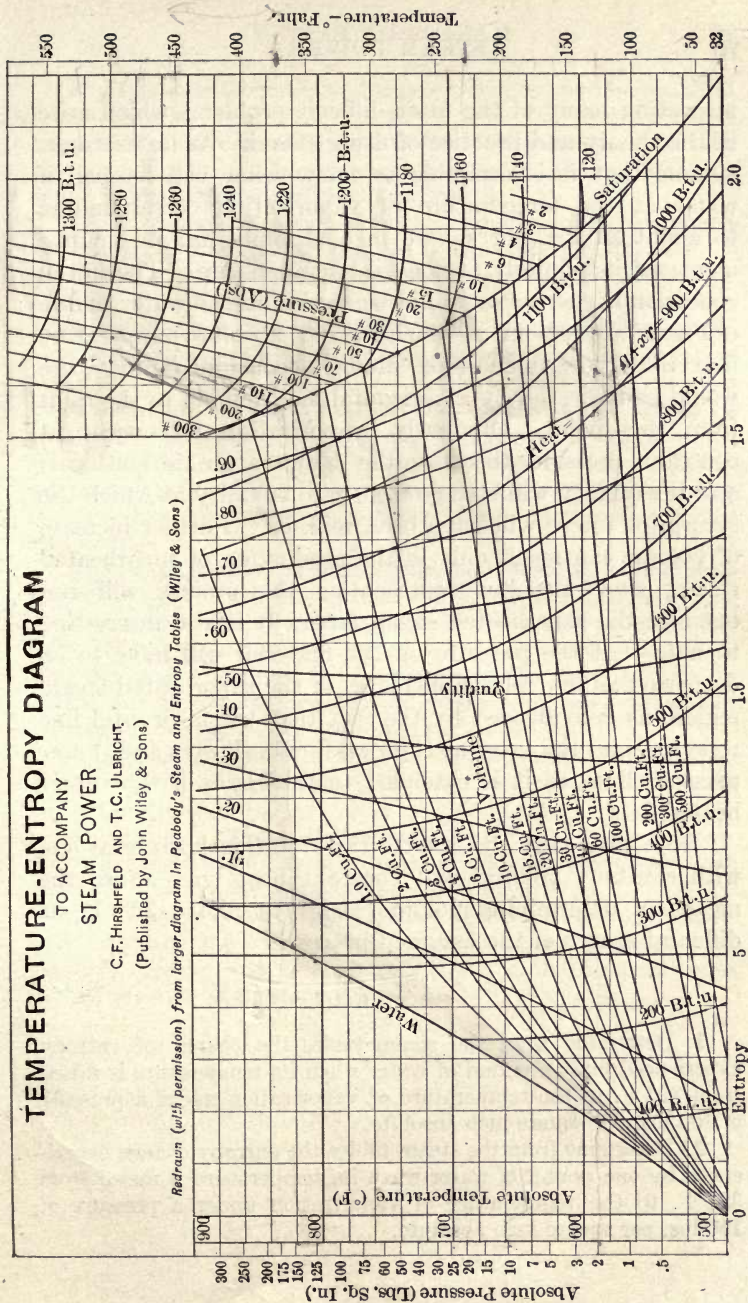

Fig. 28.

inspection many of the most difficult problems which arise in the theory and practice of using steam. As an example, assume that it is desirable to know what will happen if water at the temperature of vaporization corresponding to about 24 lbs. per square inch absolute has its volume increased indefinitely at constant temperature. The initial condition of the water would be shown on the water curve of Fig. 28 at the point at which the 700° absolute temperature line crosses it. Increase of volume at constant temperature would be indicated by a horizontal line running to the right from this point. Obviously, vaporization will occur at constant pressure (because the temperature is constant) and the quality will change from zero to unity at which the saturation curve will have been reached. Further increase of volume can result only in the production of superheated steam, since the line representing the process will run out into the superheated steam field. It is also interesting to note that the pressure on the material will have to be decreased as the volume increases in the superheated steam region, as is evidenced by the fact that the horizontal line representing the assumed process cuts lower and lower pressure lines as it is extended to the right in the superheated field.

Note also that the intersections of this horizontal line with constant volume and constant heat lines afford the means of determining volume and heat above 32° F. at different stages of the assumed process.

PROBLEMS

1. Determine from the steam tables the change of entropy experienced by one pound of water when its temperature is raised from 32° F. to the temperature of vaporization under a pressure of 100 lbs. per square inch absolute.

2. Determine from the steam tables the entropy change experienced by one pound of water when its temperature is raised from 32° F. to the temperature of vaporization under a pressure of 150 lbs. per square inch absolute.

3. Determine the entropy change experienced by one pound of water when its temperature is raised from the temperature of vaporization corresponding to 100 lbs. per square inch to that corresponding to 150 lbs. per square inch by subtracting the value found in Prob. 1 from that found in Prob. 2.

4. Determine the change of entropy experienced by one pound of material completely vaporizing at a temperature of 327.8° F.

5. Plot a $T\phi$ -chart for one pound of water. Start by plotting entropy of the liquid for various temperatures; then plot entropy of saturated steam (above 32° F.); finally draw water line, saturation line, and several lines showing change of entropy during vaporization.

6. Determine from a $T\phi$ -chart the quality which would be attained by one pound of steam if it experienced a change which carried it from the condition of dry saturated steam at 150 lbs. per square inch absolute to a pressure of 25 lbs. per square inch absolute by a process which would plot as a vertical line on the $T\phi$ -chart.

7. Assume a pound of mixed water and steam to have a quality of 80% at a pressure of 200 lbs. per square inch absolute. Determine from the $T\phi$ -chart the heat above 32° per pound of mixture and the volume occupied by the mixture. Determine also the quality attained if the pressure of the material drops to 20 lbs. per square inch absolute at constant entropy. How does the heat above 32° F. change during such a process?

8. Assume a pound of mixture as in Prob. 7, but with a quality of 30% at a pressure of 200 lbs. Find all quantities called for in that problem.

9. Assume a pound of material as in Probs. 7 and 8 above, but superheated 200° at a pressure of 200 lbs. per square inch absolute. Determine all quantities called for in Prob. 7.

10. Choose a point on the $T\phi$ -chart at which a constant volume line intersects the saturation curve. Determine the change of quality, entropy and heat above 32° F., if the material drops to half pressure at constant volume.

CHAPTER VI

TEMPERATURE ENTROPY DIAGRAMS OF STEAM CYCLES

47. Complete Expansion Cycle. This cycle was considered in Chapter IV and the PV -diagram was given there as Fig. 21. The diagram of this cycle drawn to $T\phi$ -coordinates is shown in Fig. 29. The same letters are used to represent corresponding points in the two diagrams.

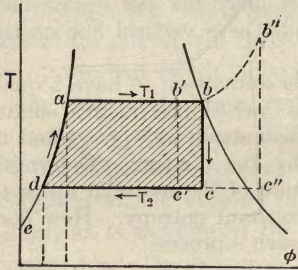

FIG. 29.— $T\phi$ -diagram, Complete Expansion Cycle.

The entropy change during the heating of the liquid is shown by the part of the liquid line between d and a , and the heat supplied during that process is represented by the area below the line da , measuring clear down to the absolute zero of temperature.

The entropy change during vaporization is represented by the line ab and the heat supplied during the process is shown by the total area under that line.

The adiabatic expansion of the steam is represented by the line bc , such an adiabatic change fortunately being a constant entropy process and therefore easily drawn in this diagram. Obviously no heat is received or removed during this process, as there is no area under the line bc .

The entropy change during condensation is represented by the line cd and the heat rejected by the working substance during this process is represented by the area under that line.

48. Area of Cycle Representative of Work. It will be remembered that area under a line in the PV -diagram represents work in foot-pounds. That diagram, however, gives no indication of heat received or rejected and it is not possible to obtain any direct idea of efficiency from it. In this respect, the $T\phi$ -diagram is much better. Area under the lines da and ab in Fig. 29 represents heat supplied the working substance. Area under the line cd represents heat rejected by the working substance. The difference between these two, or the area enclosed within the lines of the cycle, must therefore represent the heat converted into mechanical energy per cycle.

This diagram therefore shows directly by areas the heat supplied, the heat rejected, and the heat converted into mechanical energy. Further, the ratio of the area representing heat converted into work, and the area representing heat supplied must be the efficiency of the cycle.

Remembering also that if the lines of the cycle are drawn upon a $T\phi$ -chart such as that given in Fig. 28, all volume changes, heat contents and qualities at different points are shown without further work, it becomes evident that this form of representation is decidedly convenient and far superior to the pressure volume method.

49. Modifications for Wet and Superheated Steam. The complete expansion cycle is supposed to represent an idealization of what happens in a real prime mover. In real cases, however, the steam may arrive at the prime mover wet or superheated and it is desirable to investigate the method of representing such conditions as well as their effects.

Wet steam corresponds to incomplete vaporization, i.e., a quality less than unity at the upper right-hand corner of the cycle. This might be shown for a given case by the location of the point b' in Fig. 29. The cycle would then be $ab'c'd$ and a smaller amount of work would be obtained per pound of working substance as evidenced by the smaller area enclosed within the lines of the cycle.

In the case of superheated steam, superheating occurs at constant pressure after vaporization is complete. This would be shown by the location of the upper right-hand corner of the cycle at some point b'' on the constant pressure line which extends out from b . The cycle is now represented by $abb''c''d$ and evidently has a different shape than it had in the preceding cases. Obviously the area enclosed within the lines of the cycle is greater than it was before and therefore more mechanical energy is obtained per pound of steam.

50. Incomplete Expansion Cycle. The only difference between the incomplete and complete expansion cycles is

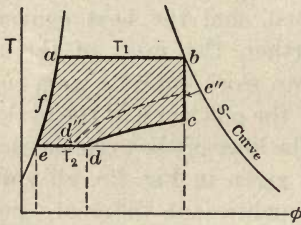

FIG. 30.— $T\phi$ -diagram, Incomplete Expansion Cycle.

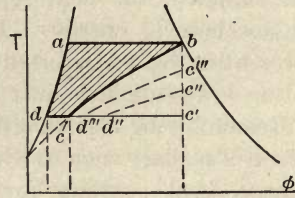

FIG. 31.— $T\phi$ -diagram, Cycle Without Adiabatic Expansion.

the termination of the expansion in the former by means of a constant volume line. This is shown to $T\phi$ -coordinates in Fig. 30 in which the incomplete expansion cycle is drawn in heavy lines over the one in which expansion continues to the back pressure.

The constant volume line is seen to cut off a corner, thus reducing the area representing heat converted into work. The heat supplied in each case is measured by the area under the lines ea and ab . The efficiency of the cycle with incomplete expansion can therefore be seen to be less than that of the other cycle by simple inspection of the diagram.

If the adiabatic expansion is terminated at a higher

pressure, as by the constant volume line $c''d''$ in Fig. 30, still more of the work area is lost, but the same quantity of heat is supplied, and therefore the efficiency is still lower than when the expansion terminated at c . Obviously as the point at which the adiabatic expansion is terminated moves nearer and nearer to b as shown in Fig. 31, the cycle becomes less and less efficient. If the constant volume line starts at b , there is no adiabatic expansion and the cycle becomes that previously considered as having a rectangular shape in the PV -diagram. This cycle has the shape indicated by $abcd$ in the $T\phi$ -diagram of Fig. 31. Obviously it is least efficient of all as was previously shown by other means.

51. Effect of Temperature Range on Efficiency. It has already been stated (see p. 26) that heat engines receive heat at a high temperature, convert some of it into mechanical form and discharge the remainder at a lower temperature. Inspection of the $T\phi$ -diagram shows this very clearly, and, remembering that the area of the cycle measures the heat converted, these diagrams also show how raising the upper temperature (or pressure) or lowering the lower temperature (or pressure) will increase the efficiency. It can be seen readily that lowering the lower temperature will, however, be more effective in increasing the efficiency than raising the upper temperature.

PROBLEMS

- † 1. Draw a complete expansion cycle to $T\phi$ -coordinates for the following conditions (using $T\phi$ -diagram for steam to get values); weight of working substance, 1 lb.; initial pressure, 125 lbs. absolute; quality at beginning of adiabatic expansion, 100% back pressure, 10 lbs. absolute.
2. Determine the following values for cycle drawn in Prob. 1:
 - (a) Entropy of liquid at beginning of vaporization;
 - (b) Entropy at beginning of adiabatic expansion;
 - (c) Quality at end of adiabatic expansion;
 - (d) Volume at end of adiabatic expansion.
 - (e) Entropy at end of condensation.

- + 3. Show by measuring the area on $T\phi$ -diagrams, the increase of efficiency resulting from the use of an initial pressure of 175 lbs. absolute and from the use of a terminal pressure of 2 lbs. absolute in place of the values given in Prob. 1.
- + 4. Compare the efficiency of a complete expansion cycle with conditions as in Prob. 1 with a complete expansion cycle with same pressures but with a temperature of 500° F. at the beginning of the adiabatic expansion.
5. Draw an incomplete expansion cycle to $T\phi$ -coordinates for the same pressures as in Prob. 1, but with adiabatic expansion ending at a pressure of 15 lbs. absolute.
6. Compare work and efficiency of the two cycles of Probs. 1 and 5 above.
7. Draw a cycle without expansion for the conditions of Prob. 1 to $T\phi$ -coordinates and compare the work area with that obtained in Probs. 1 and 5.

CHAPTER VII

THE REAL STEAM ENGINE

52. Operation of Real Engine. In previous chapters the ideal steam engine was considered and several cycles upon which it might be operated were discussed. Real engines are built to operate on the same cycles, but because of certain practical considerations they only imperfectly approximate the ideal performance.

Real engines must be built of iron and steel for practical reasons and these metals absorb, conduct and radiate heat so that certain heat interchanges between the working substance and engine and certain heat losses occur in practical operation. These were eliminated in the ideal case by simply assuming ideal materials not possessed of the characteristics of real metals.

It is also practically impossible to generate steam in the cylinder of a real engine as was assumed to be done in the ideal case. Heat is practically obtained by the combustion of fuels, and the higher the temperature attained the better can the liberated heat be utilized in the generation of steam. To subject the cylinder to such high temperatures and to control the heating and cooling as necessary to produce a number of cycles in rapid succession would lead to rapid wear and great practical difficulties. It has been found best to generate the steam in a boiler which is properly equipped for that purpose and then to transmit it with its contained heat to the engine, which is constructed in such a way as to utilize that heat to the best advantage. If the steam is to be condensed, as assumed in the ideal cases, it has also been found best to remove it from the

cylinder and to condense it in a separate piece of apparatus properly constructed for that purpose.

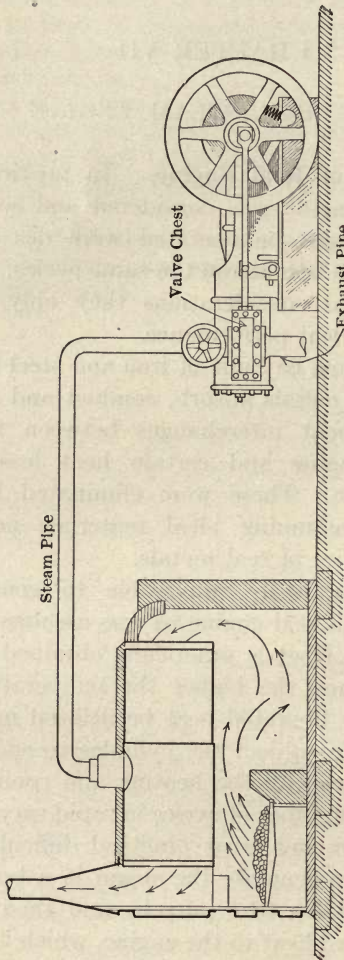

FIG. 32.—Elementary, Non-condensing Plant.

The entire arrangement which results from these practical modifications in the case of a non-condensing engine

is shown in Fig. 32. Steam is generated within the boiler at some constant pressure P_1 and at the proper instant the admission valve at one end of the cylinder is opened, allowing steam to flow in and drive the piston outward. If there were no losses, this would be represented by some such line as ab at a height P_1 on the PV -diagram of Fig. 33. Closing of the valve after the piston had moved part way out would cut off the further flow of steam, and, with continued motion of the piston, the steam within the cylinder would expand. If no heat interchanges occurred, this expansion bc would be adiabatic as in the real case.

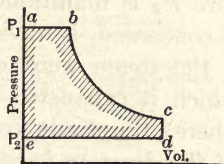

FIG. 33.

It will be observed that the two lines on the PV -diagram thus far produced represent equally well the corresponding two lines of the complete or incomplete-expansion cycles. The heat supplied in the boiler is the same as that supplied in the cylinder under the ideal conditions originally assumed, and the work under the line ab is equal to the external work done during vaporization just as in the ideal case. If difficulty is experienced in connection with the statement regarding external work, it is only necessary to picture the process in this way: Assume that each pound of steam formed in the boiler does the external work equivalent to APu by pushing the pound previously generated ahead of it as a piston, and that this motion communicated along the pipe from layer to layer results in pushing an equivalent weight (and volume) into the cylinder against the resistance offered to the piston's motion.

When the piston arrives at the end of its stroke at the point c , the opening of the "exhaust valve," connecting the interior of the cylinder with the space in which the pressure P_2 lower than P_c is maintained, will permit some of the steam to blow out of the cylinder with the piston standing stationary at the end of its stroke. This would

give a constant volume change equivalent to the corresponding line in the incomplete-expansion cycle.

The return of the piston from d to e , with the exhaust valve still open, would force the remainder of the steam out of the cylinder and into the space in which the pressure P_2 is maintained. The result, so far as the diagram is concerned, is obviously the same as in the ideal case, and if the steam were condensed within a proper vessel into which it exhausted (instead of being exhausted to atmosphere), the result would also be the same so far as the shape of the diagram is concerned. The pressure P_2 might, however, be maintained at a lower value, thus giving a greater temperature range.

The pressure rise ea within the cylinder would result directly from the opening of the admission valve and the admission of steam for the next cycle. But, if the working substance is to be returned to starting conditions as was done in the ideal case, its pressure must also be raised to P_1 and its temperature to a corresponding value. The pressure is raised in the case of condensing operation by means of the *boiler feed pump*, which picks up the condensed steam (condensate) and forces it into the boiler. The temperature of the working substance is raised by passing it through *feed-water heaters* or by heat absorbed directly from the heated water in the boiler.

When operating non-condensing the working substance exhausted during the last part of each cycle is really thrown away by allowing it to mix with the atmosphere, but an equivalent quantity of water is fed to the boiler by the boiler feed pump and takes the place of the material lost by exhaust to atmosphere. This method of operating does not approximate the ideal as closely as does the condensing method, but the discrepancy is not very great.

53. Losses in Real Installations. The diagram given in Fig. 33 was obtained by assuming the absence of certain practical losses and is considerably modified when real

apparatus is used. Thus the real engine, as shown in connection with Fig. 9, has *clearance* and operates with *compression* so that the clearance is filled with steam at a pressure indicated by the point a' in Fig. 34 when the admission valve opens.

There is also always some drop of pressure along the steam pipe so that the pressure at the engine is lower than at the boiler. Further, the admission valve can never be made to give such a large opening into the cylinder that there is not a measurable drop of pressure in flowing through it. As a result of these actions the highest pressure attained within the cylinder as indicated at point a in Fig. 34 is always lower than the boiler pressure P_1 .

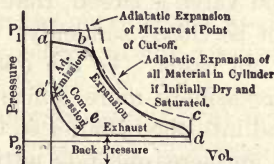

FIG. 34.—Theoretical and Real Indicator Diagrams.

As the piston of a real engine moves out it acquires a higher and higher velocity until it reaches a point near mid-stroke. The entering steam therefore must flow through the valve with increasing velocity if it is to follow up the piston and fill the cylinder, but this usually necessitates greater pressure drops as the piston moves out, so that the admission line generally slopes downward instead of being horizontal. There is also another phenomenon which causes this line to slope. The metal of cylinder, cylinder head and piston is in contact with comparatively low-temperature steam during the latter part of each cycle, and therefore acquires a lower temperature than that of the steam about to enter. Therefore, when the high-pressure steam enters the cylinder it gives up heat to the walls at a comparatively rapid rate, and, if initially dry saturated, this results in a great deal of condensation. Such condensation is called **initial condensation**.

As the steam condenses after flowing into the cylinder and forms water occupying a negligibly small volume,

it follows that steam must flow into the cylinder at a proportionately greater rate in order to fill the space vacated by the piston. But this results in an increased pressure drop and therefore would give a sloping admission line.

When the piston has finally been driven out as far as desirable by the action of high-pressure steam, the admission valve is closed, that is, **cut-off** occurs. This valve can not be closed suddenly; the closure is more or less gradual in all cases. As the opening becomes smaller it becomes increasingly more difficult for the steam to flow through and into the cylinder so that the pressure continues to drop at an increasing rate until the valve is finally closed. This gives the rounded cut-off shown at the point *b*.

The loss of pressure during admission is generally said to be due to **throttling** or **wire drawing**, these terms being intended to convey the idea that the steam has to squeeze its way through the inlet openings with corresponding loss of pressure.

When the cut-off has finally been completed, it leaves the end of the cylinder filled with a mixture of steam and water at steam temperature, and this mixture then expands as shown by the line *bc*. At the beginning of the expansion the steam generally has a higher temperature than that of the surrounding walls and it therefore continues to give heat to those walls. Were the expansion adiabatic it would follow the dot-dash line in the figure, but, as the steam must not only convert heat into work, but must also supply heat to the walls, it condenses more rapidly than in the ideal case and its pressure and volume changes follow some such law as that indicated by the upper part of the curve *bc*.

As expansion continues, the pressure and temperature of the steam drop until some point is reached at which the temperature has become equal to that of the walls. Further expansion with drop of pressure and temperature results in reducing the temperature of the steam below

that of the walls, and then the direction of heat transfer is reversed, the hot walls giving heat to the cooler steam at an increasingly rapid rate. This heat causes *re-evaporation* of some of the water formed before and thus tends to increase the volume occupied by the material in the cylinder, with the result that the lower part of the expansion curve *bc* approaches and generally crosses the curve which would have been attained by adiabatic expansion in non-conducting apparatus.

In many real engines the re-evaporation is so great that the steam is entirely dried and sometimes superheated before the exhaust valve opens.

The exhaust valves of steam engines are always opened before the piston reaches the end of the stroke, as it is found necessary to do this if excessive losses are not to occur due to the difficulty of forcing the large volume of low-pressure steam through the exhaust passages. When opened early enough, the steam flows out in such quantity before the end of the stroke that the "back pressure" during the return or exhaust stroke is only a pound or two above that of the space into which the engine is exhausting.

During all of the exhaust period, the steam is probably at a lower temperature than the walls to which it is exposed and re-evaporation probably continues in most cases until the closure of the exhaust valve. It seems probable that the steam retained in the cylinder after the closure of the exhaust valve is approximately dry, but little is really known regarding the quality of the clearance steam.

The rise of pressure during compression has two beneficial effects: It helps to bring the moving parts to rest gradually, and it raises the temperature of the clearance steam and of the walls of the clearance space to values nearer that of the entering steam.

Remembering that area on a *PV*-diagram represents work, it is easily seen that throttling losses and rounding of corners due to slow valve action (which cause a loss of

diagram area) result in a loss of work. The fact that condensation also causes a great loss is easily shown. A given quantity of steam entering the engine with its supply of heat can, in the ideal case, do a certain amount of work at the expense of that heat. In the real case part of the heat is stored in the walls during the early part of the cycle, so that it is not available for the doing of work and is removed from the walls and carried out into the exhaust as unutilized heat during the later part of the cycle. The phenomenon can be pictured by imagining the steam as dropping some of its heat into a pocket in the walls of the cylinder when entering the engine and then picking it up again and carrying it out when leaving, so that the next charge of steam will have to fill the pocket again.

The net result of condensation and re-evaporation is the obtaining of less work from a given quantity of steam than should be obtained, or the use of more steam than theoretically necessary for a given quantity of work. This effect is shown graphically by the two adiabatic expansion lines of Fig. 34.

The initial condensation in real engines which are supplied with saturated steam generally amounts to from 20 to 50 per cent of all the steam supplied, so that it is evident that anything which will prevent part or all of this loss should do much to improve the steam consumption of engines. This subject will be discussed in more detail in later paragraphs and various methods of decreasing losses from this source will be considered.

54. Clearance. The term clearance is used in a two-fold sense; (a) to refer to **mechanical clearance** or the *linear distance* between the two nearest points of cylinder head and piston face when the piston is at the end of its stroke, and (b) to refer to **volumetric clearance** or the *volume* enclosed between the face of the valve, the cylinder head and the face of the piston when the latter is at the end of its stroke.

The former is generally given in inches and varies from a very small fraction of an inch in the best engines to an inch or more in cheap and in poorly designed engines. It is indicated by *a* in Fig. 35.

The volumetric clearance is expressed as a percentage of the piston displacement or volume swept through by the piston. It varies from 2 per cent or less in the best engines to as high as 15 per cent in the cheaper and less economical models. It is made up of the parts designated by *c* in Fig. 35.

55. Cushion Steam and Cylinder Feed. It is customary to imagine the steam operating within an engine cylinder to consist of two parts, the *cushion steam* and the *cylinder feed*. The former is that part of the total which is contained in the clearance space before the admission valve opens and serves to *cushion* the reciprocating parts of the engine. The cylinder feed is the steam which enters through the valve for each cycle.

If the same cycle is produced time after time so that all temperature effects are repeated at regular intervals and so that all events occur at the same points in successive cycles, the quantity of steam retained in the clearance volume will be the same for successive cycles. It is impossible to measure the quantity of this steam directly and indirect methods are therefore adopted for that purpose.

It is often assumed that the steam is dry and saturated when compression begins, as at the point *e* in Fig. 34. With this assumption, the weight of cushion steam can be determined by dividing the volume occupied, that is,

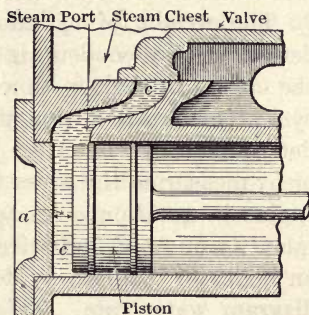

FIG. 35.—Mechanical and Volumetric Clearances.

V_e , by the volume occupied by one pound of dry saturated steam at the same pressure. Thus,

$$\text{Cushion steam} = \frac{V_e}{\text{Sp.vol. at pressure } P_e} \text{ lbs.} \quad (29)$$

The weight of cylinder feed can be very accurately determined by condensing and weighing the steam leaving the engine in a given time and dividing by the number of cycles performed during the same period. It can also be determined by metering the steam entering the engine or by measuring the water fed to a boiler supplying only the engine in question. An approximate determination of the quantity of the cylinder feed can also be made directly from an indicator diagram by determining what is known as the **diagram water rate**. This will be considered in detail at a later point.

When cushion-steam and cylinder-feed have both been determined, the *weight* of steam contained in the cylinder between cut-off and release can be found by adding the two quantities. Thus,

$$W = W_f + W_K, \quad \dots \dots \dots (30)$$

in which

W = total weight of steam expanding in cylinder per cycle;

W_f = weight of cylinder feed per cycle; and

W_K = weight of cushion steam per cycle.

The *volume* which the mixture would occupy if dry and saturated at any given pressure can be determined by multiplying W the total weight by the specific volume for that particular pressure.

56. Determination of Initial Condensation. The loss due to initial condensation is so important that it is customary to determine the amount of this loss when studying engines. This can be done with fair accuracy by means of the indicator diagram.

To make such a study it is necessary to know the total weight of material in the engine cylinder at the point of cut-off. This weight may be determined by any of the methods just given. With the weight known, the volumes which this material should occupy at different pressures if dry and saturated can be determined by multiplying by the specific volumes at the various pressures. Plotting these points on a PV -diagram and connecting them will give a *saturation curve* for the material in the cylinder such as the curve shown in Fig. 36.

By drawing this curve on the indicator diagram obtained from the engine and then comparing distances such as ab and ac as explained in section 26 of Chapter III

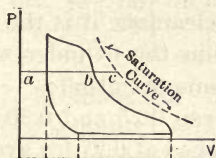

FIG. 36.

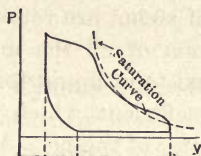

FIG. 37.

the quality of the steam within the cylinder at all pressures between cut-off and release can be determined. The weight of initial condensation (up to the point of cut-off) must be the total weight of water shown as existing within the cylinder at that point minus any water brought in by the steam if it was not dry when entering the engine.

Should the saturation curve cross the real expansion curve, as shown in Fig. 37, it indicates that the steam occupies volumes greater than the specific volumes toward the end of the expansion; the steam within the cylinder must therefore be superheated during this part of the cycle.

Many formulas have been devised for giving the quantity of initial condensation. They are all based upon the results of experiment and generally only give reliable

values for cases similar to those used in developing them. One formula of this sort which has been very widely tested and been found to give reliable results within its field of applicability is that devised by Robert C. H. Heck and explained in his books on the steam engine. The formula is

$$m = \frac{c}{\sqrt[3]{N}} \sqrt{\frac{s\theta}{pe}}, \quad \dots \quad (31)$$

in which

m = the fraction representing initial condensation; for ordinary cases it is the fraction of the cylinder feed which is condensed during admission, but when compression is very high and when great weights of steam are retained in the clearance it is the fraction of all the material within the cylinder which exists in liquid form at the time of cut-off;

c = a coefficient, which varies between 0.25 and 0.30 with type of engine. May be assumed at 0.27 for average work;

N = engine speed in revolutions per minute (R.P.M.);

s = a constant for any engine, equal to nominal surface in square feet divided by nominal volume in cubic feet. The nominal surface is the area of the inner walls and the ends of a cylinder with diameter equal to the internal diameter of the cylinder and with a length equal to the stroke of the engine. The nominal volume is the cubic contents of such a cylinder;

$s = \frac{12}{D} \left(2\frac{D}{S} + 4 \right)$ in which D and S represent diameter and stroke of engine in inches;

θ = a temperature function obtained from Table II as there indicated;

p = the absolute pressure in cylinder in pounds per square inch just after completion of cut-off;

e = cut-off ratio, that is, ratio of cylinder volume opened up by time cut-off has just been completed to the total piston displacement.

TABLE II

FOR FINDING VALUES OF θ FOR USE IN HECK FORMULA

$\theta = k_1 - k_2$ when k_1 and k_2 are chosen from table for highest and lowest pressures existing in cylinder

p	k	p	k	p	k	p	k	p	k	p	k
1	175	15	210	50	269.5	90	321.5	160	389	230	441
2	179	20	220	55	277	100	332.5	170	397	240	447.5
3	183	25	229	60	284	110	343	180	405	250	454
4	186	30	238	65	291	120	353	190	413	260	460.5
6	191	35	246	70	297.5	130	362.5	200	420	270	467
8	196	40	254	75	304	140	371.5	210	427	280	473
10	200	45	262	80	310	150	380.5	220	434	290	479

57. Methods of Decreasing Cylinder Condensation.

Before discussing methods of decreasing the loss due to cylinder condensation it will be well to consider what things may be expected to determine the extent of such loss. The condensation is due directly to the transfer of heat from one body to another at lower temperature, and anything which tends to increase the total amount of heat thus transferred will increase the total condensation.

It is therefore evident that the ratio of steam condensed to steam supplied will be greatest when:

- (a) The time of contact is greatest;
- (b) The ratio of surface exposed to volume enclosed is greatest, and
- (c) The temperature difference is greatest.

The time of contact can be controlled to a certain extent by controlling the speed of the engine and, with other things equal, the higher the speed the lower should be the condensation.

The ratio of surface exposed to steam to the volume occupied by steam has a great influence on the amount of

condensation which occurs. The surface of the clearance space, including the interior surfaces of all ports or passages leading to the valves, seems to have the greatest influence, and the clearance space which is most nearly a short cylinder without connected passages may be expected to give the least initial condensation.

The size of the engine is also important in this connection. The area exposed does not increase as rapidly as does the volume inclosed when the diameter of a cylinder is increased, and therefore large cylinders give smaller ratio of surface to volume and therefore a smaller percentage of steam condensed. Large engines thus have a decided advantage over small engines.

The shape of the cylinder also has an effect. The longer the cylinder with respect to its diameter the more favorable its performance.

The point at which cut-off occurs is also intimately connected with the condensation loss. In a given cylinder with a given clearance the total condensation within the clearance space may be assumed practically constant if speed and temperature remain about the same. But if the cut-off is made later larger quantities of steam are admitted per stroke, and hence the fraction of the total cylinder feed which is condensed decreases.

The temperature differences depend on upper and lower pressures, that is, on the pressure range. The inner surfaces of the walls follow as rapidly as possible the temperature changes of the steam within them. Thus their average temperature is somewhere between the upper and lower temperatures of the steam. If now, with a given upper steam pressure and therefore temperature, the lower pressure be reduced, the average wall temperature also will be reduced, and therefore the differences between the temperature of the entering steam and the average temperature of the walls will be increased with a resulting increase in condensation loss.

The methods of decreasing this loss can now be considered. They are given below under separate heads with brief explanation when necessary.

(a) Clearance spaces should be properly designed so that the minimum surface is exposed.

(b) The proportions of cylinder (diameter and stroke) and the speed of the engine should be so chosen that the condensation loss is reduced to a minimum.

(c) The engine should be so proportioned that when delivering its rated power the cut-off occurs at such a point as to make the percentage of cylinder condensation the minimum consistent with other requirements.

(d) The cylinder should be surrounded by spaces filled with air or by materials which are poor conductors of heat so as to decrease loss by radiation, because all heat lost in this way must be supplied by the condensation of steam within the cylinder. Such metallic parts as cannot be "lagged" in this way should be polished because polished surfaces radiate less heat than dull surfaces under like conditions.

(e) The cylinder may be surrounded by a steam jacket, that is, a space filled with steam similar to that supplied the cylinder. The use of such a jacket sometimes results in a considerable saving and at other times in a great loss. The cylinder proportions, speed and pressure range seem to be the determining factors, and most long-stroke cylinders operating at low rotative speed and with small pressure ranges are jacketed.

(f) The engine may be compounded, that is, the expansion of the steam may be made to occur in two or more cylinders taking steam in series. This results in decreasing the pressure range in each of the cylinders and effects a decided saving under proper conditions. Compounding will be considered in detail in a later chapter.

(g) The engine may be supplied with superheated steam. If the steam is sufficiently superheated it can give up part or all of its superheat to heat the cylinder walls, and thus no

condensation need occur. Heat interchanges between metal and superheated steam also appear to be less rapid than is the case when the steam contains water, so that a saving results from this source also.

Tests made with saturated and with superheated steam indicate that from 7° to 10° of superheat are generally required to prevent 1 per cent. of initial condensation. Results differ greatly with the character of the engine, with its economy on saturated steam, with its valve gear, etc. Superheats of from 25° to 50° can generally be used with any well-designed engine, but higher temperatures usually require specially constructed engines. Superheats as high as 150° F. above saturation temperature are now quite common, and there seems to be a tendency to consider a value between 150° and 200° as the highest that is commercially advisable under ordinary conditions.

✓ **58. Classification of Steam Engines.** Steam engines, are classified on many different systems, the one used in any particular case being determined largely by circumstances. The principal methods of classification are indicated in the following schedule:

CLASSIFICATION OF STEAM ENGINES

<i>On the basis of rotative speed</i>	{	Low speed Medium speed High speed									
<i>On the basis of ratio of stroke to diameter</i>	{	Long stroke Short stroke									
<i>On the basis of valve gear</i>	{	<table style="border-collapse: collapse;"> <tr> <td style="padding-right: 10px;">Slide valve</td> <td style="font-size: 3em; vertical-align: middle;">{</td> <td style="padding-left: 10px;"> <i>D</i>-slide valve Balanced slide valve Multiported slide valve Piston valve </td> </tr> <tr> <td style="padding-right: 10px;">Corliss valve</td> <td style="font-size: 3em; vertical-align: middle;">{</td> <td style="padding-left: 10px;"> Drop cut-off Positively operated </td> </tr> <tr> <td style="padding-right: 10px;">Poppet valve</td> <td style="font-size: 3em; vertical-align: middle;">{</td> <td style="padding-left: 10px;"></td> </tr> </table>	Slide valve	{	<i>D</i> -slide valve Balanced slide valve Multiported slide valve Piston valve	Corliss valve	{	Drop cut-off Positively operated	Poppet valve	{	
Slide valve	{	<i>D</i> -slide valve Balanced slide valve Multiported slide valve Piston valve									
Corliss valve	{	Drop cut-off Positively operated									
Poppet valve	{										

- On the basis of position of longitudinal axis { Vertical
Inclined
Horizontal
- On the basis of number of cylinders in which steam expands { Single expansion or Simple engine
Multi-expansion engine { Compound expansion
Triple expansion
Quadruple expansion
- On the basis of cylinder arrangement { Single cylinder
Tandem compound
Cross compound
Duplex
- On the basis of use { Stationary engines
Portable engines
Locomotive engines
Marine engines
Hoisting engines

59. Rotative Speeds and Piston Speeds. High-speed engines operate at a comparatively high rotative speed and are characterized by a short stroke in comparison with the diameter of the cylinder, the stroke generally being equal to, or less than, the diameter. The piston speed, by which is meant the feet travelled by the piston per minute, generally falls between 500 and 700.

It is not considered advisable to allow piston speeds of stationary steam engines to exceed about 750 feet per minute for ordinary constructions and the great majority of engines give much lower values. The piston speed will obviously be given by the formula

$$S = 2LN, \dots \dots \dots (32)$$

in which

- S = piston speed in feet per minute;
- L = stroke in feet; and
- N = revolutions per minute,

and it is evident from this formula that as the rotative speed is increased the piston speed will increase unless the length of stroke is proportionately decreased. As a result, high-speed engines have short strokes in com-

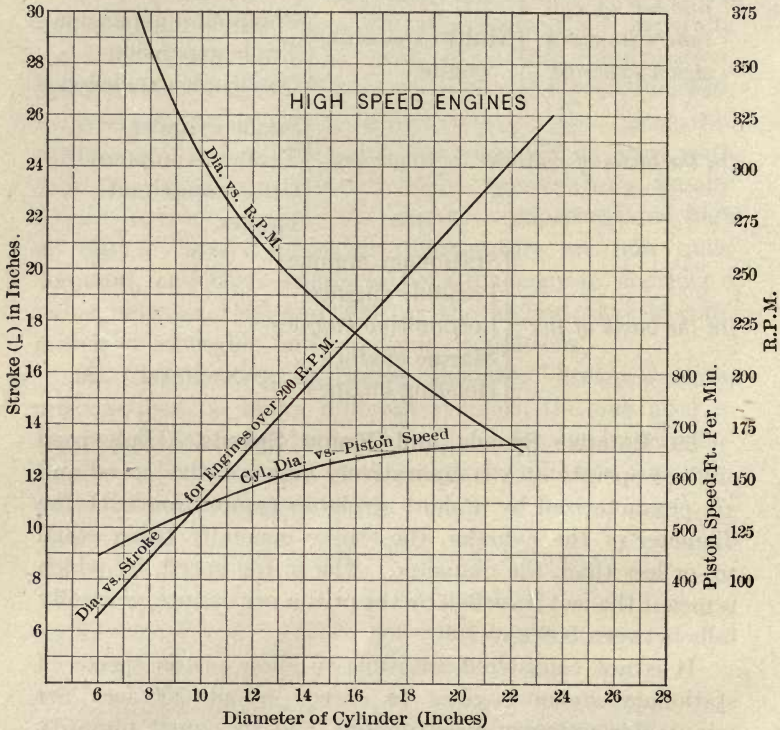

FIG. 38.—Proportions of High Speed Engines.

parison with their cylinder diameters and slow-speed engines have long strokes.

The characteristic relations between cylinder diameter and stroke, rotative speed and piston speeds of high-speed engines are given in Fig. 38.

High-speed engines are generally fitted with some

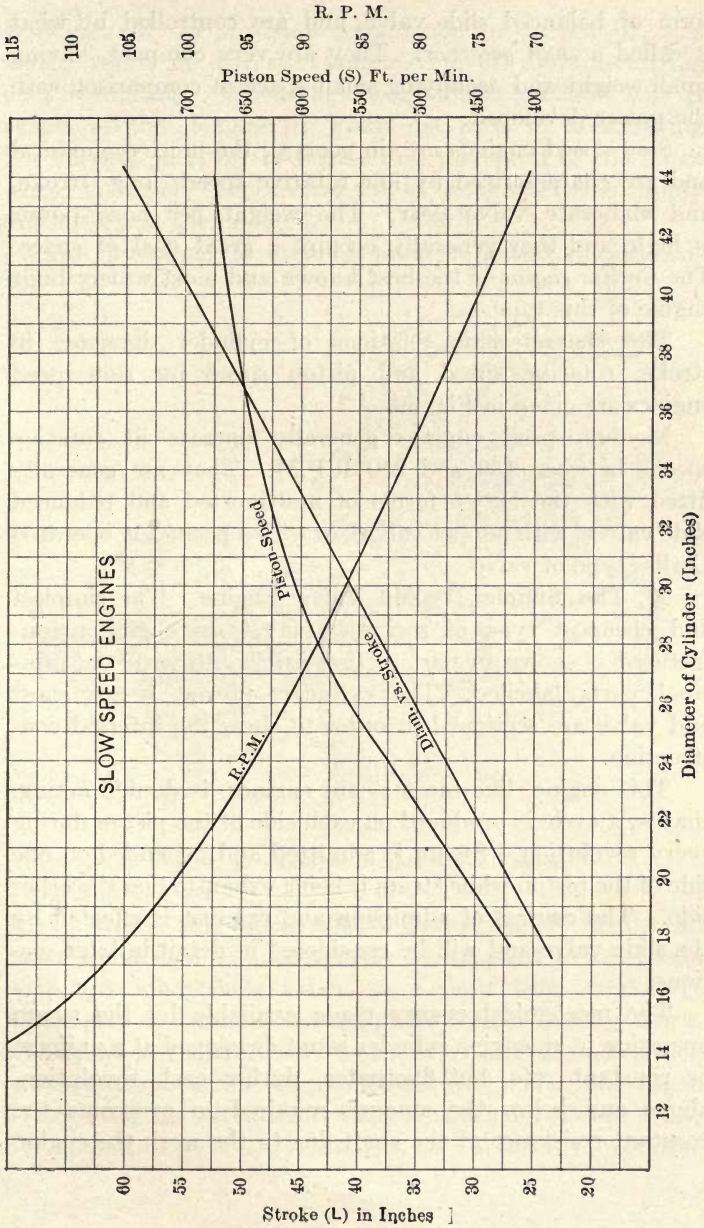

FIG. 39.

form of balanced slide valve, and are controlled by what is called a *shaft governor*. They are very compact, having small weight and occupying small space in comparison with the power developed.

Slow-speed engines are, in general, the most economical and are characterized by low rotative speed, long stroke, and elaborate valve gear. The weight per horse-power is high, and they generally occupy a great deal of space. The *Corliss engine* is the best known and most widely built engine of this type.

The characteristic relations of cylinder diameter to stroke, rotative speed and piston speed for slow-speed engines are given in Fig. 39.

Medium-speed engines generally operate at rotative speeds between 150 and 250 R.P.M. They are generally fitted with the better forms of multiported and balanced slide valves, with poppet valves, or with a positively operated Corliss type of valve.

60. The Simple D-slide Valve Engine. The simplest and cheapest type of reciprocating steam engine manufactured is shown in part section in Fig. 40 with the principal parts labelled. The cylinder, piston, steam chest and valve are sectioned in order to show the internal construction.

This engine, like most steam engines, is double acting, that is, a cycle is produced on each side of the piston during every revolution. Steam is admitted and expanded on one side of the piston while steam is being exhausted on the other side. The control of admission and exhaust is effected by the slide valve and will be considered in detail in later sections.

The mechanical energy made available by the steam operating in an engine cylinder is not developed at a uniform or constant rate, but fluctuates, during each revolution, above and below the amount required to overcome the constant resistance at the shaft due to the work the engine

is doing. If no provision were made to prevent it, this would result in a very variable rate of rotation during each revolution. When the energy made available was in excess of the demand it would be used in accelerating the moving parts of the engine and the speed of the latter would increase. The reverse would occur when the supply did not equal the demand.

The fly-wheel is used to prevent violent fluctuations

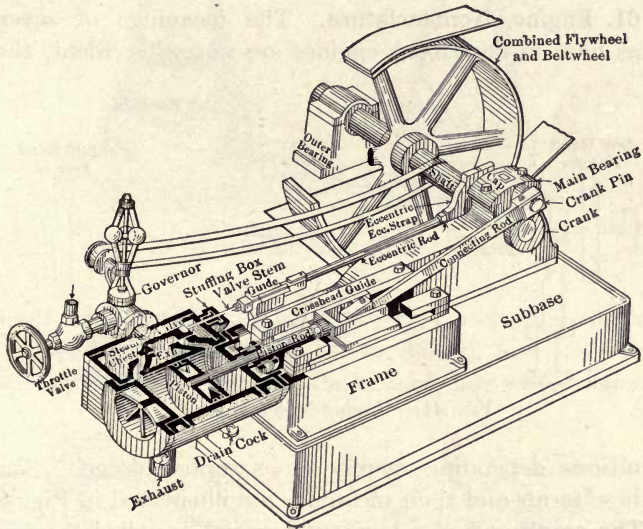

FIG. 40.—Simple *D*-slide Valve Engine.

of this kind. It is made with a comparatively heavy rim and a great deal of energy must be supplied to accelerate it to any appreciable extent in a short time. Similarly it can give out a great deal of energy when slowing down. The fly-wheel therefore serves as a sort of reservoir in which excess energy can be stored temporarily and from which it can later be withdrawn when a deficiency exists. The fly-wheel thus acts as a damper to variation of rotative

speed during each revolution, minimizing but not entirely eliminating such variation. It may also serve as a belt wheel, as shown in the illustration.

The **governor** controls the steam supply to the cylinder in such a way that enough heat will be supplied to make available the power demanded at the shaft. Were more supplied the excess would be absorbed by the moving parts and the engine speed would increase, were less supplied the engine speed would decrease.

61. Engine Nomenclature. The meanings of several terms used in describing engines are not self-evident, their

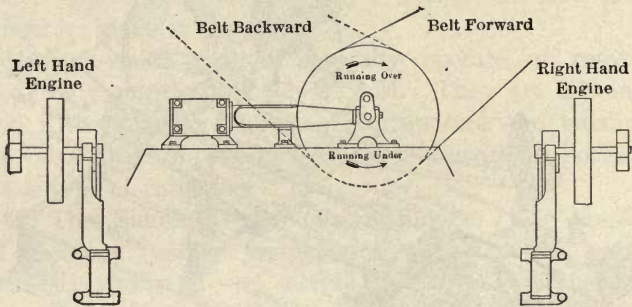

FIG. 41.—Engine Nomenclature.

definitions depending merely on accepted usage. Some of these terms and their meanings are illustrated in Fig. 41.

The **crank end** of a horizontal engine is called the **front** of the engine, so that the cylinder head nearest the crank is called the front head and the stroke of the piston toward the crank is known as the **forward stroke**. The forward stroke of the piston is also spoken of as the **outstroke**, particularly in connection with single acting engines. The stroke away from the crank is correspondingly designated as the return or the **instroke**.

62. Principal Parts of Engines. The parts of engines may be roughly divided into *stationary* and *moving*, such as frame, cylinder, cylinder and valve chest covers, etc., which

are stationary, and piston, piston rod, crosshead, fly-wheel, etc., which are all moving parts when the engine is in operation. The moving parts are often divided into *reciprocating*

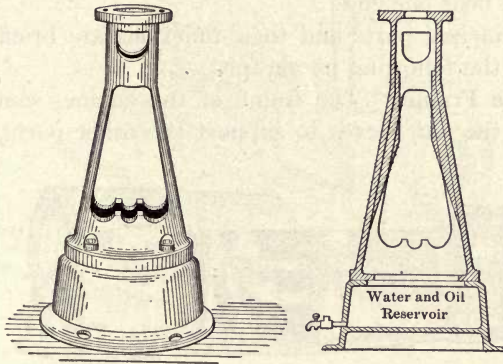

FIG. 42.—Frame for Small Vertical Engine.

and rotating parts. Thus the piston and all connected parts through and including the crosshead, and the valve and many connected parts in the case of slide valve engines,

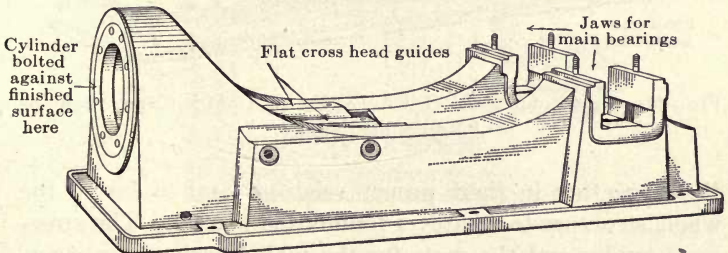

FIG. 43.—Frame for Medium Speed Center Crank Engine.

all reciprocate when the engine is in operation. The shaft, fly-wheel, eccentric sheaves and governor constitute the principal rotating parts.

Some engines also have *oscillating* parts, such as the valves in Corliss types, which rock back and forth in the arc of a circle, and the rocker arms in various forms of valve gear, these arms rocking through a short arc about a fixed pin near one end.

The principal parts and their functions are briefly considered in the following paragraphs:

(a) **The Frame.** The frame of the engine, sometimes known as the *bed*, serves to support the other parts, to tie

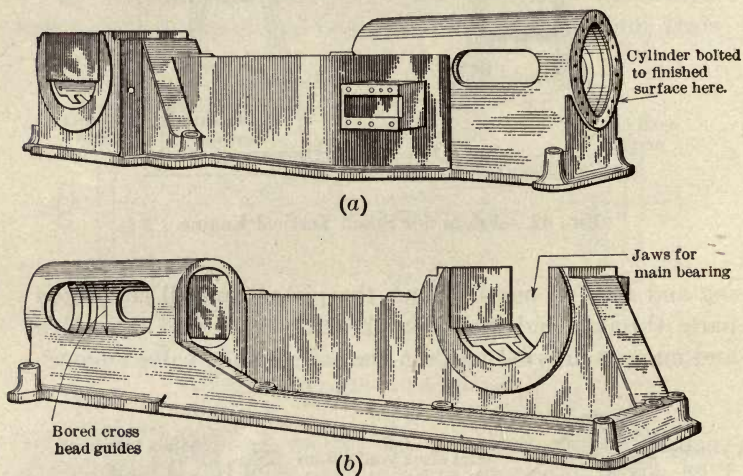

FIG. 44.—Frame for Slow Speed Engine of Corliss Type; Side or Overhung Crank.

them together in their proper relations and to fasten the whole structure to whatever foundation is used. The cross-head guides and the seats for the main bearings are incorporated in the frame.

The frame is commonly made of cast iron in the form of a hollow box which is properly ribbed to give the necessary stiffness.

Examples of frames are shown in Figs. 42, 43 and 44.

(b) **The Cylinder and Steam Chest.** The cylinder and steam chest are generally incorporated in the same casting, and surfaces of covered cavities in this casting are finished

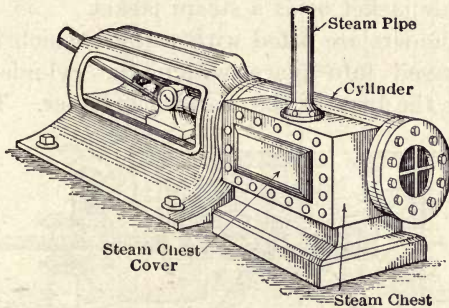

FIG. 45.

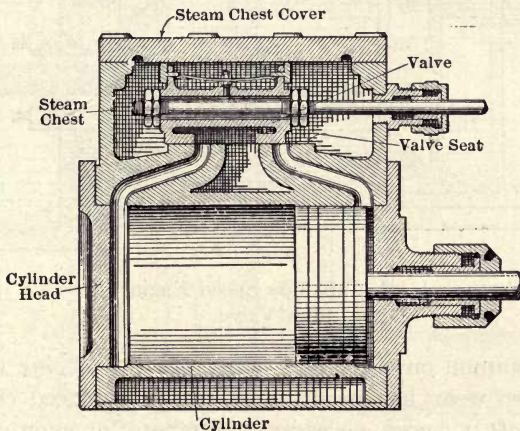

FIG. 46.

to form the cylinder in which the piston operates and the seat or seats upon which valves rest and move.

The cylinder may be *single walled* with flanges on the end to receive the cylinder head, as illustrated in Fig. 40

(plain *D*-slide valve), in which case a thin sheet-metal jacket is fastened around it and the space between filled with heat-insulating material. Or, the cylinder may be cast with *double walls*, the space between the two being used as an air jacket or as a steam jacket.

Some cylinders are fitted with a *liner*, which is a plain cylinder pressed into place within the cylinder casting and forming the bore of the working cylinder. This prac-

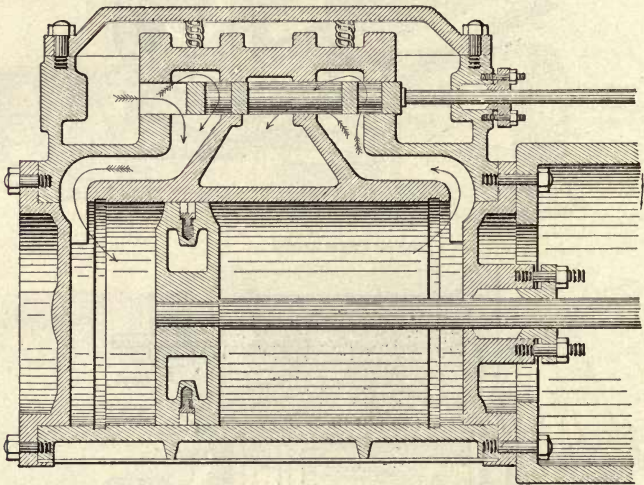

FIG. 47.—Section of Atlas Medium Speed Engine, Showing Balanced Slide Valve.

tice is common on the larger types, the liner being used so that when wear has occurred it can be replaced cheaply, instead of it being necessary to rebores or even replace the main casting.

Examples of cylinder construction are shown in Figs. 45, 46, 47, 48, 49 and 50.

(c) **The Piston.** The function of the piston is two-fold. It must prevent the leakage of steam by it from one end of the cylinder to the other, and it must receive the

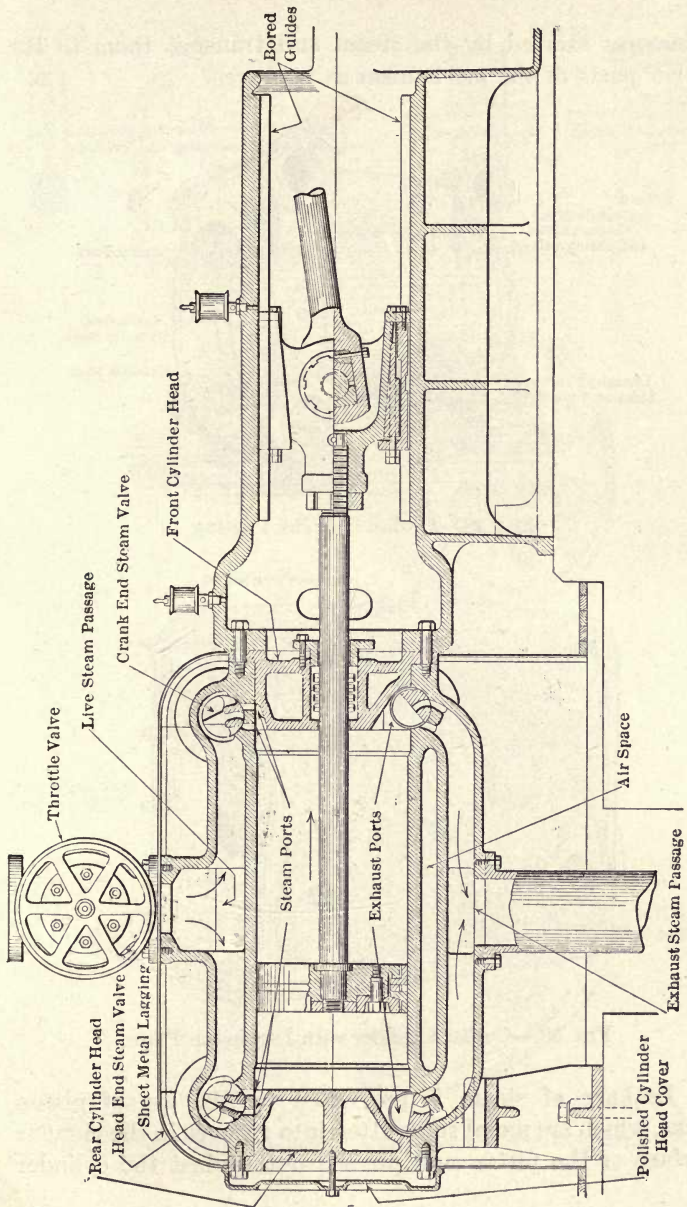

FIG. 48.—Section of Corliss Cylinder and Guides, and Half-section of Crosshead.

pressures exerted by the steam and transmit them to the other parts of the mechanism as it moves.

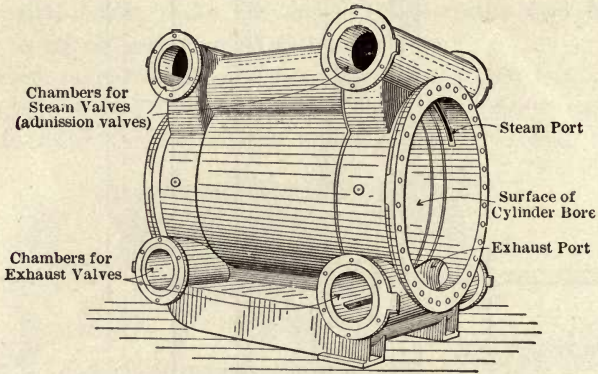

FIG. 49.—Corliss Cylinder Casting.

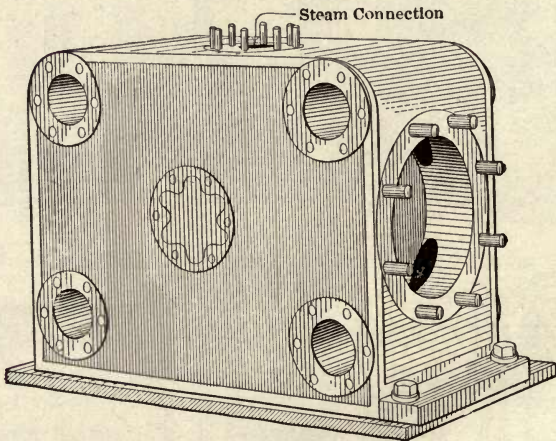

FIG. 50.—Corliss Cylinder with Lagging in Place.

Leakage of steam is prevented by the use of piston rings, which are metal rings fitted into grooves in the circular surface of the piston and pressed out against the cylinder

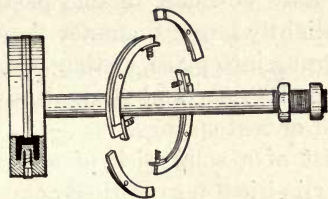

FIG. 51.

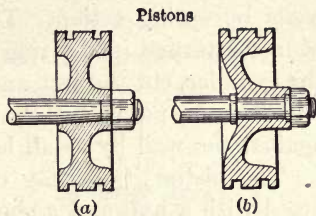

FIG. 52.

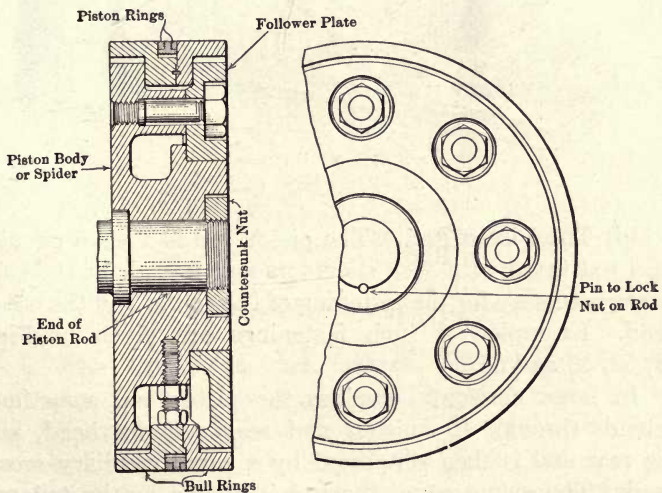
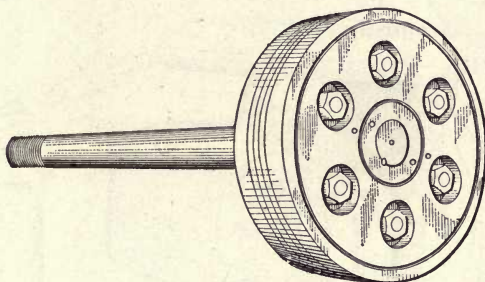

FIG. 53.—Built-up Piston Used in Large Engines.

walls by spring action. They may be made of one piece of metal turned into a ring of slightly larger diameter than the cylinder, cut through and sprung into place, or they may be made in pieces as shown in Fig. 51, and pressed out against the wall by small helical or leaf springs.

The piston itself may consist of a solid disk of metal fitted with a hub and a short cylindrical part with grooves for the rings, as shown in Fig. 52 (a) and (b), or it may be an elaborate built-up structure, as shown in Fig. 53.

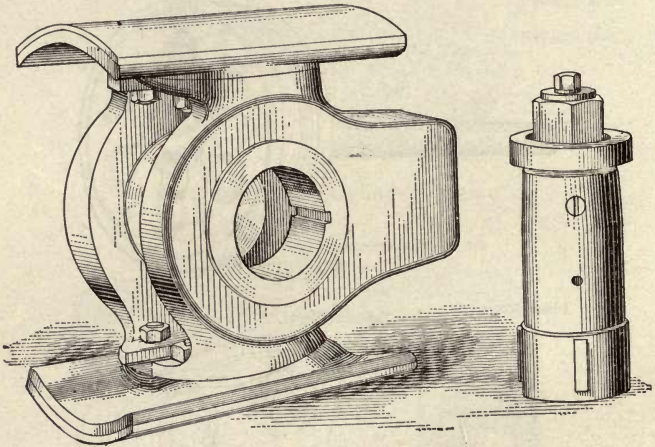

FIG. 54.—Crosshead and Pin.

(d) **The Piston Rod.** The piston rod is a plain circular steel rod fitted with such shoulders and threads at the ends as are necessary for the fastening of the piston and the cross-head. Examples of such fastenings are given in Figs. 51, 52, 53 and 55.

In large horizontal engines the piston rod sometimes extends through the piston and rear cylinder head, and the rear end is then supported by a small auxiliary cross-head. The extension of the rod is known as the **tail rod** and the auxiliary crosshead as the **tail rod crosshead**.

Such constructions are used when the weight of the piston is so great that it would cause serious cylinder wear if not supported more perfectly than is possible with the ordinary overhung arrangement.

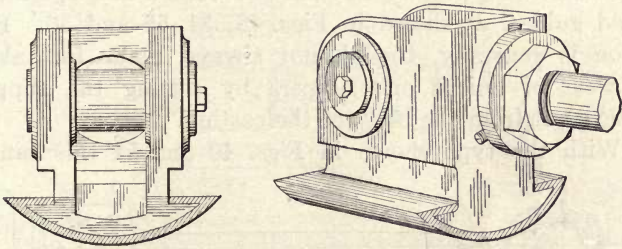

FIG. 55.—Single Slipper Crosshead.

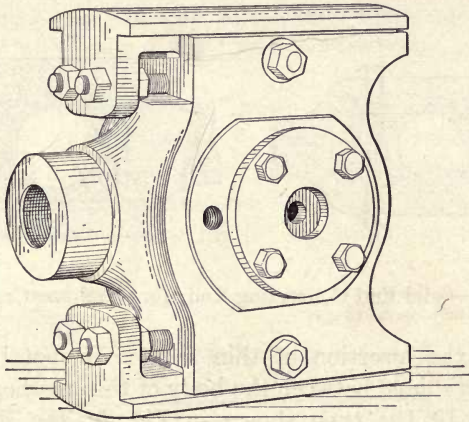

FIG. 56.—Crosshead with Adjustable Slippers.

(e) **The Crosshead and Guides.** The crosshead and guides are used for the purpose of supporting the piston and its rod and guiding them in a straight line. The crosshead also serves to connect the piston rod and the connecting rod through which the forces are transmitted to the crank pin.

Crossheads are generally cast in the form of imperfectly shaped boxes and carry slippers which are faced with anti-friction metal where they come in contact with the guides. The slippers may be flat and operate on planed guides, as shown in Fig. 40, or they may be turned and operate in bored guides, as shown in Figs. 48, 54, 55 and 56. Provision is generally, though not always, made for taking up wear of guides and slippers by setting the slippers further out from the body of the casting.

With the type shown in Figs. 40 and 54 this can be

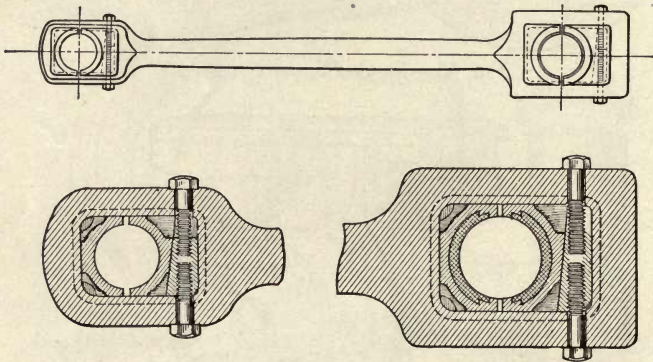

FIG. 57.—Solid End Connecting Rod; for Overhung Cranks only.

done by the insertion of thin sheets of metal or paper (known as shims) between the body of the crosshead and the slippers. In the type shown in Fig. 56 the slippers are finished with inclined surfaces where they come in contact with the main casting, and the adjustment is made by wedging the slippers apart by the use of the adjusting bolts shown.

The wrist-pin end of the connecting rod enters the crosshead casting and is held in place by means of the wrist pin, about which it oscillates when the engine is in operation.

(f) **The Connecting Rod.** This rod connects the reciprocating crosshead with the rotating crank shaft and transmits the forces from one to the other. It consists of a body or shank and two ends or heads. The ends may

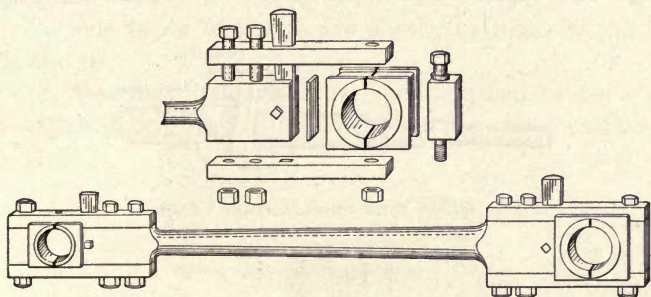

FIG. 58.—Connecting Rod with Bolted Strap Ends; May be Used with Center or Side Crank Constructions.

be “closed” or “solid” as shown in Fig. 57; they may be made with a strap bolted in place as shown in Fig. 58; or the crank-pin end may be made of two half boxes bolted together to form a “marine end” as shown in Fig. 59.

The ends are always made adjustable so that wear

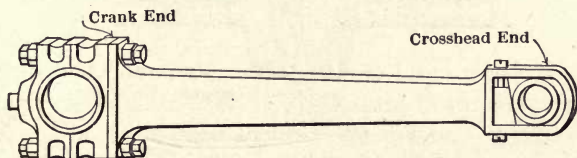

FIG. 59.—Marine End Connecting Rod.

can be taken up, thus preventing noisy operation due to hammering between the ends and the pins at times when the direction in which forces act is reversed. With solid and strap types this adjustment is generally made by means of wedges similar to those shown in Figs. 57 and 58.

With the marine type shims are used between the two halves, and the diameter of the hole formed by the latter is decreased by the removal of shims of the required thickness.

(g) **The Shaft.** The crank shaft itself is generally made

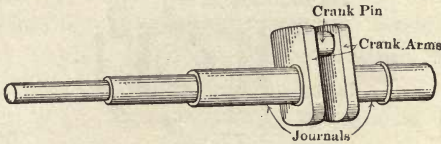

FIG. 60.—Crank Shaft, Center Crank.

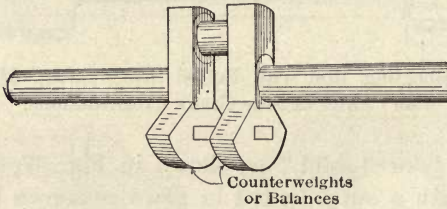

FIG. 61.—Center Crank.

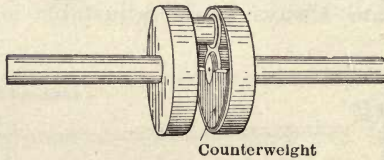

FIG. 62.—Center Crank.

of steel, but the counterbalances are often of cast iron. It may be one forging throughout or may be built up by shrinking the various parts together. Multicrank shafts of large size are generally of built-up construction, the crank pins being shrunk into the crank arms and the latter shrunk on to the pieces of shaft.

The counterbalance weights are used to balance the

centrifugal effect of the crank pin, part of the crank arms and part of the connecting rod, all of which rotate off center. In some engines part of the unbalanced effect of the reciprocating parts is also imperfectly balanced by these counter-balances.

Various types of shafts are shown in Figs. 60, 61, 62, 63, and 64.

(h) **Bearings.** Bearings are distinguished as *main* and as *outboard* bearings. Main bearings are those carried by

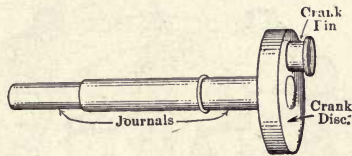

FIG. 63.—Crank Shaft and Disc, Overhung Crank.

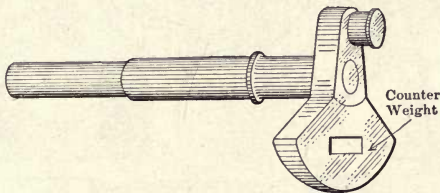

FIG. 64.—Overhung Crank.

the frame of the engine and outboard bearings are carried by separate pedestals or by pedestals fastened to a plate which is in turn fastened to the frame. Center-crank engines have two main bearings, and side-crank engines only have one, the other end of the shaft being supported by an outboard bearing.

The bearings of steam engines are generally formed of babbitt-lined boxes carried within jaws machined in a frame, or in a separate pedestal, and held in place by a bearing cap. The boxes are made in two, three or four parts to allow for adjustment to compensate for wear and

to give a certain degree of flexibility. Adjustment for wear is either made by means of wedges or by means of screws which force the various parts of the boxes toward the shaft. An example of a three-part bearing with screw adjustment as used with large side-crank engines is shown in Fig. 65. The parts of a three-part bearing with wedge adjustment are shown in Fig. 66.

Bearings are often lubricated by rings or chains, and they are then known as ring- or as chain-oiling bearings.

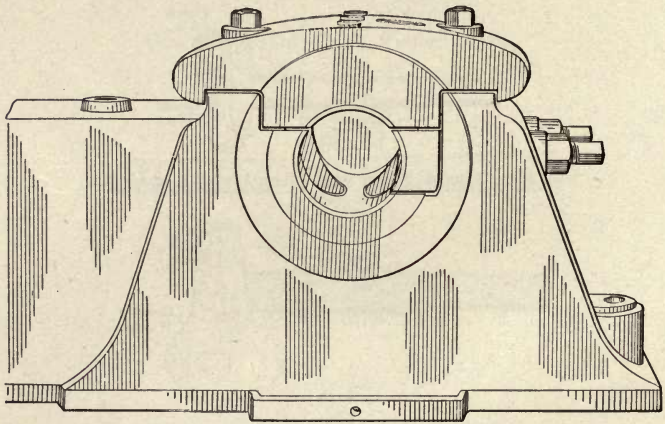

FIG. 65.—Three Part Main Bearing with Screw Adjustment.

In the ring-oiling bearing one or more metal rings of large diameter hang loosely on the shaft within the bearing and dip into an oil reservoir below the shaft. Rotation of the shaft causes the rings hanging on it to rotate and they carry oil up from the reservoir and spill it out over the shaft within the bearing. Chain bearings are similar except that chains are substituted for rings.

(i) **Fly-wheels.** The function of the fly-wheel has already been considered and need not be discussed further. The wheel is constructed with a heavy rim joined to a hub

by six or eight arms. In the smaller sizes the wheel may be cast in one piece, but best practice calls for a split hub in that case to partly equalize certain casting strains which result from unequal thicknesses of metal in different parts of the wheel. Large wheels are cast in two or more parts both for the purpose of partly avoiding casting strains and for the purpose of facilitating handling and shipping.

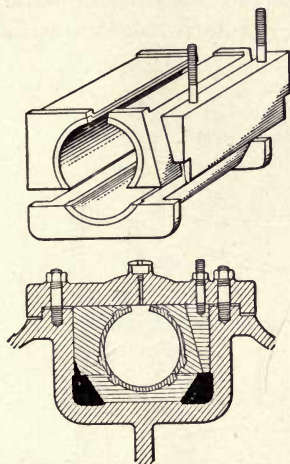

FIG. 66.—Three Part Bearing Showing Wedge Adjustment.

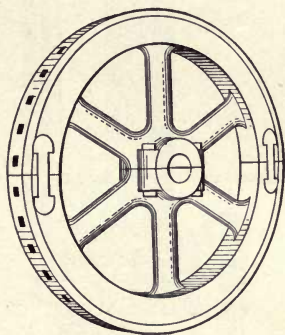

FIG. 67.

A two-part wheel with the rim sections joined by prisoner links shrunk in place and the hub fastened with bolts is shown in Fig. 67.

PROBLEMS

1. A given engine has a piston displacement of 3 cu.ft. and a clearance volume of 3%. Compression begins when 85% of the exhaust stroke has been completed and the pressure within the cylinder at that time is 16 lbs. per square inch absolute. Determine the weight of the cushion steam on the assumption that this steam is dry and saturated at the beginning of compression.

2. Assume the engine described in Prob. 1 to cut-off at $\frac{1}{4}$ stroke and with a pressure inside the cylinder equal to 115 lbs. per square inch absolute. Find the weight of cylinder feed if the quality of the material in the cylinder at the time of cut-off is 75%.

3. Find the piston speed of an engine with a stroke of 2 ft. and a rotative speed of 150 R.P.M.

4. Show by means of Heck's formula that initial condensation increases with pressure range.

CHAPTER VIII

THE INDICATOR DIAGRAM AND DERIVED VALUES

63. **The Indicator.** The ideal steam engine cycle was described in Chapter IV, and the sort of diagram which would be obtained from a real engine was shown in Chapter

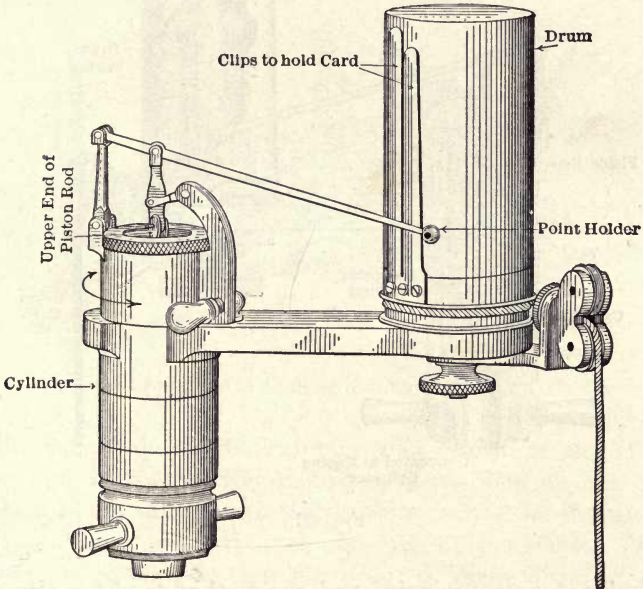

FIG. 68.

VII; but the means by which such diagrams are obtained from operating engines was not given.

Indicator diagrams showing the pressure and volume changes experienced by steam in the cylinders of real

engines are obtained by means of an instrument known as an **indicator**. The operation of obtaining such diagrams is known as *indicating the engine*.

An external view of one form of indicator is shown in Fig. 68 and a section through the instrument is given in Fig. 69. The method of connecting an indicator to the

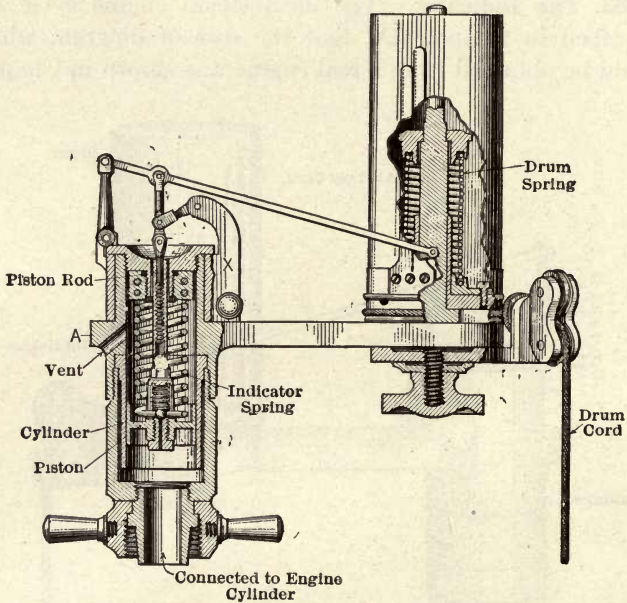

FIG. 69.

cylinder of a steam engine and one method used for driving it are illustrated in Fig. 70.

The indicator is intended to draw a diagram showing corresponding pressures and volumes within the engine cylinder and must, therefore, contain one part which will move *in proportion to pressure* variations and another which will move *in proportion to volume* changes. The one may

be called the pressure-measuring and the other the volume-measuring device.

The pressure-measuring device generally consists of a piston, such as shown in the figure, working with minimum friction in a small cylinder and fitted with a spring which will resist what may be called outward motion (upward in the figure). The cylinder containing this piston is coupled to a short pipe connected with the clearance space of the engine and, whenever the indicator cock in this connection is open, the steam acting on the engine piston

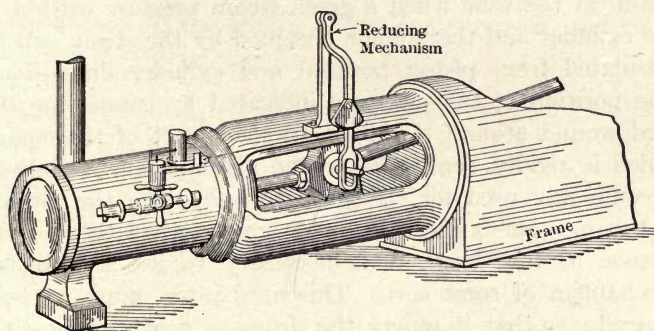

FIG. 70.—Method of Attaching and Operating an Indicator.

will also act on the indicator piston. Steam of any given pressure will drive the indicator piston out against the action of the spring until the pressure exerted by the spring is equal to that exerted on the face of the piston. The indicator piston will thus move out different distances for different pressures, and, through the piston rod and pencil mechanism, will move the pencil point to various heights corresponding to different steam pressures. The pencil mechanism is so arranged that the point traces a straight vertical line on the drum as the indicator piston moves in and out.

Springs are made to certain definite scales, thus there

are, for instance, 10-lb., 25-lb., 50-lb. and 100-lb. springs. The number which is known as the **scale of the spring** designates the steam pressure in pounds per square inch which is required to move the pencil point 1 inch against the action of such a spring. With a 100-lb. spring in the indicator, a steam pressure of 50 pounds per square inch acting on the indicator piston would drive the pencil up a distance of half an inch, a pressure of 100 pounds per square inch would give 1 inch of motion and so forth.

The volume-measuring device is of an inferential kind. It simply indicates the position attained by the engine piston at the time when a given steam pressure existed in the cylinder and the volume occupied by the steam can be calculated from piston position and cylinder dimensions. The position of the piston is indicated by connecting the cord wound around the drum to some part of the engine which is rigidly connected to the piston. The crosshead is commonly used for this purpose and, since the motion of this member is generally much greater than the circumference of the drum, it is necessary to use a **reducing mechanism** of some sort. This mechanism must be very accurate, so that it moves the drum as nearly as possible in proportion to the motion of the engine piston.

The pencil point moves up and down as the pressure within the cylinder varies, and the drum rotates under the point in proportion to the motion of the engine piston, so that the combination of the two motions brings the pencil point to successive positions on the drum which indicate successive corresponding values of steam pressure and piston position. By mounting a piece of paper, known as a card, on the drum and pressing the pencil point upon this paper, the successive positions occupied by the pencil point will be recorded in the form of a series of curves and straight lines.

If the drum is rotated with the lower side of the indicator piston connected to atmosphere, the pencil will trace

a horizontal line. This is known as the **atmospheric line** and is used as a reference for locating the pressure scale. If the indicator cylinder is then connected with the engine cylinder and the drum is rotated by the reducing mechanism, a diagram similar to that of Fig. 71 will be drawn upon the card. The atmospheric line indicates the height assumed by the pencil when atmospheric pressure acts on the piston and, knowing the value of the existing atmospheric pressure (barometer reading) and the scale of the spring, a line at a height representing zero pressure can be drawn on the card. This line is indicated in Fig. 72.

The length of the card between the lines *a* and *b* is proportional to the length of the engine stroke and there-

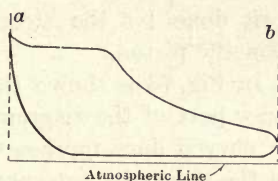

FIG. 71.

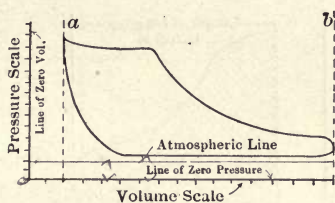

FIG. 72.

fore to the piston displacement, that is, to the *volume* swept through by the piston. Knowing the clearance volume of the engine as a percentage or fraction of the piston displacement, this fraction of the length of the diagram can be laid off from the end of the diagram to give a line of zero volume. This line is also indicated in Fig. 72.

With the line of zero pressure and the line of zero volume drawn in, all values of steam pressure and volume occupied by steam can be read directly from the diagram, and it thus forms a picture of what occurs within the real engine cylinder.

The indicator diagram is used for a number of purposes, the more important being:

(1) The determination of the energy made available within the cylinder, that is, the indicated horse-power, I.h.p.

(2) The determination of the amount of initial condensation and of heat interchanges between walls and cylinder.

(3) The determination of what is known as the diagram water rate.

(4) The study of the operation and timing of valves. The second one of these uses has already been considered in Chapter VII, the others are treated in succeeding sections.

64. Determination of I.h.p. The lines of the indicator diagram show by their height the pressures or forces acting on the engine piston as it moves. But *the product of force by distance is equal to work* and these lines can be used therefore for determining the net work done by the steam upon the piston.

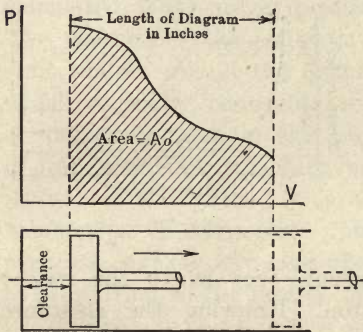

FIG. 73.—Positive Work Area.

the area of the piston face, this product would be the average total force acting on the piston. Multiplying this by the distance traveled would give the work done by the steam upon the piston. Expressed in the form of an equation,

$$E_0 = p_0 \times a \times L \text{ ft.-lbs., (33)}$$

in which

- E_0 = work done upon piston by steam during outstroke;
- p_0 = mean pressure (in pounds square inch) acting on piston during outstroke;

a = area of piston face in square inches; and
 L = stroke of piston in feet.

For the instroke shown in Fig. 74, the work done by the piston on the steam is given by the similar expression.

$$F_i = p_i \times a \times L \text{ ft.-lbs.}, \quad (34)$$

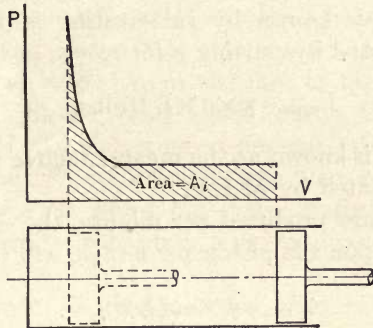

FIG. 74.—Negative Work Area.

in which E_i and p_i represent work done and mean pressure respectively.

The *net work* done by the steam upon the piston per cycle is then,

$$E_{\text{cycle}} = E_0 - E_i = (p_0 - p_i)aL \text{ ft.-lbs.} \quad . . . (35)$$

The values of p_0 and p_i can be found directly from the diagram by dividing the areas A_0 and A_i respectively by the length l and then multiplying by the scale of the spring, giving

$$p_0 = \frac{A_0}{l} \times \text{scale of spring},$$

and

$$p_i = \frac{A_i}{l} \times \text{scale of spring},$$

so that,

$$p_0 - p_t = p = \frac{A_0 - A_t}{l} \times \text{scale of spring} \quad . . . \quad (36)$$

$$= \frac{\text{area of diagram}}{l} \times \text{scale of spring.} \quad . \quad (37)$$

The value of p evidently can be determined very simply from the indicator diagram, and the work per cycle can be found when p is known by substituting in the following equation, obtained by putting p for $p_0 - p_t$ in Eq. (35),

$$E_{\text{cycle}} = p \times a \times L \text{ ft.-lbs.} \quad . . . \quad (38)$$

The pressure p is known as the **mean effective pressure** and is often represented by M.E.P.

If n cycles are produced per minute, the *net work* done by the steam upon the piston *per minute* will be

$$E_{\text{min}} = p \times a \times L \times n, \quad . . . \quad (39)$$

which is generally rearranged to read,

$$E_{\text{min}} = pLan, \quad . . . \quad (40)$$

in which form the group of letters forming the right-hand member is easily remembered.

Since 33,000 foot-pounds per minute are equivalent to one horse-power, it follows that the power made available as shown by the indicator diagram, that is, the **indicated horse-power**, must be,

$$\text{I.h.p.} = \frac{pLan}{33,000}, \quad . . . \quad (41)$$

in which

p = mean effective pressure in pounds per square inch;

L = stroke of piston in feet;

a = area of piston in square inches;

= (diam. cyl. in inches)² × π/4 = .7854d²; and

n = number of cycles per minute.

If an engine cylinder takes steam on one side of the piston only, that is, if the cylinder is *single acting*, the number of cycles produced per minute is equal to the number of revolutions per minute, but it should be noted that for other arrangements this is not necessarily true. In the case of *double-acting* engines which receive steam at both ends of the cylinder, the number of cycles produced is equal to twice the number of revolutions.

It should also be noted that the symbol a represents the area of the piston face upon which the steam acts. If a piston rod extend from the face of the piston to and through the cylinder head (as is always the case at the crank end of double-acting cylinders), the area of the piston rod must be subtracted from that of the piston to obtain the area on which the steam really acts. When a tail rod is used, a correction must be made for each side of the piston.

In the case of double-acting engines the indicated horse-power may be determined in two ways: It may be figured separately for the two ends of the cylinder, or the values for the area and pressure may be averaged for the two ends and the value of n chosen equal to twice the revolutions per minute. The former is generally the more accurate method.

It will have been observed that the area of the indicator diagram must be determined before the mean effective pressure can be found. This area is generally measured by means of an instrument known as a **planimeter**, and this is the most accurate method. It occasionally happens, however, that a planimeter is not available when the value of the indicated horse-power is desired. Under such circumstances an approximate determination of the area of the indicator diagram can be made by the method of ordinates.

For this purpose the length of the diagram is divided into an equal number of parts, usually ten, as shown in

Fig. 75 and vertical lines y_1, y_2, y_3 , etc., are drawn at the center of each of the parts into which the diagram has been divided. The mean ordinate or height is then found from the equation,

$$y_m = \frac{y_1 + y_2 + y_3 + y_4 + \text{etc.}}{\text{number of vertical lines}} \dots \dots \dots (42)$$

and the mean effective pressure is then determined by multiplying y_m by the scale of the spring.

An indicator diagram similar to that shown in Fig. 76 is occasionally obtained. The small loop on the end represents *negative work*, since the pressure of the steam which

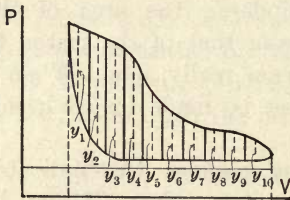

FIG. 75.

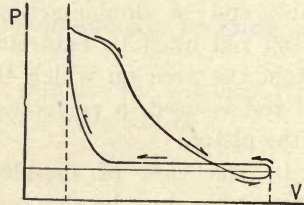

FIG. 76.

does work upon the piston is *lower than* that which resists the return of the piston. When using a planimeter, this area is automatically subtracted from that of the rest of the diagram, but care should be taken to see that this is also done when the method of ordinates is used.

ILLUSTRATIVE PROBLEM

1. Determine the I.h.p. of a double-acting steam engine, having a cylinder 8 ins. diameter, length of stroke, 12 ins., running at 100 R.P.M., the mean effective pressure (M.E.P.) on the piston being 45 lbs. Neglect the area of the piston rod.

$$\begin{aligned} \text{I.h.p.} &= \frac{pLan}{33,000} = \frac{(p \times a) \text{ lbs.} \times (Ln) \text{ ft. per min.}}{33,000 \text{ ft.-lbs. per min.}} \\ &= \frac{(45 \times 8 \times 8 \times .7854) \text{ lbs.} \times 1\frac{1}{2} \times 100 \times 2) \text{ ft. per min.}}{33,000} \end{aligned}$$

$$= \frac{2260 \text{ lbs.} \times 200 \text{ ft. per min.}}{33,000}$$

= 14 nearly.

2. The I.h.p. of a double-acting engine is 14, the R.P.M. = 100; M.E.P. = 45 lbs.; length of stroke = 12 ins. Find the diameter of the cylinder, neglecting area of piston rod.

First determine the *area* of the piston from the formula

$$\begin{aligned} \text{I.h.p.} &= \frac{pLn}{33,000} \quad \text{or} \quad a = \frac{33,000 \text{ I.h.p.}}{p \times L \times n}; \\ a &= \frac{33,000 \times 14}{45 \times 1 \times 100 \times 2} = 51.4 \text{ sq.in.} = \frac{\pi d^2}{4}; \\ d &= \sqrt{\frac{51.4}{.7854}} = \sqrt{65.4} = 8 \text{ ins. (approx.).} \end{aligned}$$

65. Conventional Diagram and Card Factors. It is often necessary to approximate the mean effective pressure obtained in the cylinder of an engine when no indicator diagrams are available. The most common case is when an engine is being designed to carry a certain load and it is desired to determine the necessary cylinder dimensions and speed. If the *probable* mean effective pressure can be determined, the dimensions and speed can be found from the equation,

$$\text{I.h.p. per cylinder end} = \frac{pLn}{33,000},$$

by rewriting it

$$\text{I.p.h.} = \frac{pLn \times 0.7854d^2}{33,000},$$

from which

$$d^2 = \frac{33,000 \text{ I.h.p.}}{0.7854 pLn} \cdot \cdot \cdot \cdot \cdot \quad (43)$$

Since *n* is equal to revolutions per minute for one cylinder end, the product of *L* by *n* must be equal to half the piston

speed of the engine, and a proper value of this product can be chosen for substitution in the equation. If a proper value for p can then be predicted the only unknown remaining will be the diameter d , and this can be found by solving the equation.

The prediction of the mean effective pressure is made either by drawing upon recorded experience in the form of values obtained in similar engines previously constructed or by means of what is known as a **conventional indicator diagram**.

The conventional diagram is drawn with upper and lower pressures equal to those expected in the case of the real engine, and all expansions and compressions are drawn as rectangular hyperbolas. The equation of the rectangular hyperbola is

$$P_1V_1 = P_nV_n, \dots \dots \dots (44)$$

in which subscript 1 indicates initial conditions and subscript n represents any later conditions with the same material in the cylinder. This law is assumed because it is the simplest and, as a rough average, gives values as close to those actually attained as do any of the more complicated laws.

The diagram may be drawn as nearly as possible like the one which the engine may be expected to give or it may be drawn with various simplifications which remove it more and more from the approximation to an actual indicator diagram. In any case, the mean effective pressure is determined from this diagram and this value is then multiplied by a corrective factor, the value of which has been determined by experience. This corrective factor is called the **diagram factor** or **card factor** and it is really the ratio of the area of the diagram the engine would really give to the area of the conventional diagram used.

The simplest form of conventional diagram is drawn

by neglecting the clearance volume and has the shape shown in Fig. 77. The upper line is drawn horizontal at a height representing the highest pressure expected and of such a length (compared with the length of the diagram) as will approximately represent the fraction of the stroke at which cut-off is to occur in the real engine. The expansion curve is then drawn in as a rectangular hyperbola and extended until the end of the diagram is reached. The next line is drawn vertical and the lower line of the diagram is drawn horizontal at a height representing the pressure expected in the space into which the engine is to exhaust.

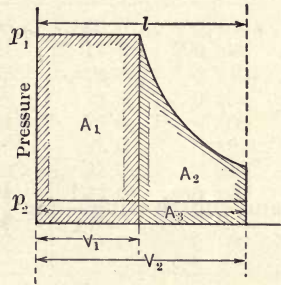

FIG. 77.—Conventional Indicator Diagram.

This simple diagram can be divided into the three areas shown and the value of the work represented by these areas can be determined from the equations given below, the first and last of which should be self-evident from what has preceded. The equation for the work represented by area A_2 can be determined very easily by means of integral calculus. The equations are,

$$A_1 \text{ represents } P_1 V_1 \text{ ft.-lbs.};$$

$$A_2 \text{ represents } P_1 V_1 \log_e \frac{V_2}{V_1} = P_1 V_1 \log_e r \text{ ft.-lbs.,}$$

and

$$A_3 \text{ represents } P_2 V_2 \text{ ft.-lbs.,}$$

in which P represents pressure in pounds per square foot and V represents volume in cubic feet.

The total area is then equal to the sum $A_1 + A_2 - A_3$ and the net work is equal to a similar sum of the right-

hand members given above. The net work must also equal the mean-effective pressure P_m multiplied by the total volume change, so that

$$P_m V_2 = P_1 V_1 + P_1 V_1 \log_e r - P_2 V_2, \quad \dots \quad (45)$$

and

$$P_m = P_1 \frac{V_1}{V_2} + P_1 \frac{V_1}{V_2} \log_e r - P_2 \quad \dots \quad (46)$$

$$= P_1 \left(\frac{V_1}{V_2} + \frac{V_1}{V_2} \log_e r \right) - P_2, \quad \dots \quad (47)$$

and substituting $\frac{1}{r}$ for $\frac{V_1}{V_2}$ this gives

$$P_m = P_1 \left(\frac{1 + \log_e r}{r} \right) - P_2. \quad \dots \quad (48)$$

The ratio $\frac{V_2}{V_1} = r$ is called the **ratio of expansion** and its reciprocal, $\frac{V_1}{V_2} = \frac{1}{r}$ is known as the **cut-off ratio**. By the use of this ratio the volume terms can be disposed of and the equation above is obtained. This equation then gives the mean effective pressure in terms of upper and lower pressures and the fraction of the stroke at which cut-off is desired in the real engine and no cylinder dimensions need be known.

Since pressures in steam-engine practice are usually given in pounds per square inch, the equation for mean effective pressure is more useful in the form

$$p_m = p_1 \left(\frac{1 + \log_e r}{r} \right) - p_2, \quad \dots \quad (49)$$

in which p_1 and p_2 and p_m are expressed in pounds per square inch absolute. For convenience in the use of this

equation the values assumed by the bracketed quantity are given for various conditions in Table III.

TABLE III

r	$\frac{1 + \log_e r}{r}$	r	$\frac{1 + \log_e r}{r}$	r	$\frac{1 + \log_e r}{r}$
1.0	1.00	6.0	0.465	16.0	0.236
1.5	0.937	7.0	0.421	17.0	0.226
2.0	0.847	8.0	0.385	18.0	0.216
2.5	0.766	9.0	0.355	19.0	0.208
3.0	0.700	10.0	0.330	20.0	0.200
3.5	0.644	11.0	0.309	21.0	0.192
4.0	0.597	12.0	0.290	22.0	0.186
4.5	0.556	13.0	0.274	23.0	0.180
5.0	0.522	14.0	0.260	24.0	0.174
5.5	0.492	15.0	0.247	25.0	0.169

The values of the mean effective pressures obtained from this form of diagram are very much higher than are to be expected from real engines with the same initial and terminal pressures and the same nominal ratio of expansion. They are therefore corrected by multiplying by the proper diagram factor as selected from Table IV. It is obvious from the range of values given that the selection of a proper value for the factor depends largely on experience, but such experience is quickly gained by contact with real engines and a study of the practical diagrams.

TABLE IV

DIAGRAM FACTORS

Simple slide-valve engine.....	55 to 90%
Simple Corliss engine.....	85 to 90
Compound slide-valve engine.....	55 to 80
Compound Corliss engine.....	75 to 85
Triple-expansion engine.....	55 to 70

66. Ratio of Expansion.—The ratio of expansion used above is sometimes called the *apparent ratio*. It is not the

real ratio of expansion for an engine with clearance. For such an engine the real ratio of expansion is

$$r' = \frac{V_2 + V_c}{V_1 + V_c} \dots \dots \dots (50)$$

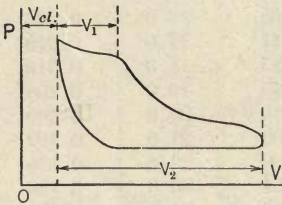

FIG. 78.

in which the symbols represent the volumes indicated in Fig. 78.

The numerical values of r and r' are often very different and care should be used in distinguishing between them. The diagram factors referred to in Table IV are for idealized conventional cards without clearance as shown in Fig. 77.

ventional cards without clearance as shown in Fig. 77.

ILLUSTRATIVE PROBLEMS

1. Given an engine with a stroke of 24 ins. and cut-off occurring at $\frac{1}{3}$ stroke. Steam pressure of 160 lbs. per square inch and back pressure of 16 lbs. Assume diagram factor = 80%. Neglecting clearance, find the probable M.E.P.

$$\begin{aligned} \text{M.E.P.} &= p \left(\frac{1 + \log_e r}{r} \right) - p_2 = 160 \left(\frac{1 + \log_e 3}{3} \right) - 16 \\ &= 160 \times .7 - 16 = 112.0 - 16 = 96 \text{ lbs.} \end{aligned}$$

Hence probable M.E.P. = .80 × 96 = 76.8 lbs.

2. A given double-acting engine indicates 75 I.h.p. under the following conditions:

Cut-off at 20%; steam pressure, 140 lbs. per square inch absolute; piston speed, 600 ft. per minute; back pressure, 2 lbs. per square inch absolute.

Assume a diagram factor for this type of engine equal to 85%; and neglecting clearance, find a convenient size of the cylinder (diameter and stroke).

Solution.

$$r = \frac{1}{.20} = 5;$$

$$p_m = p \left(\frac{1 + \log_e r}{r} \right) - p_2 = 140 \left(\frac{1 + \log_e 5}{5} \right) - 2 = 140(.522) - 2$$

$$= 73.1 - 2 = 71.1 \text{ lbs. per sq.in.}$$

Diagram factor = 85%. Hence probable

$$\text{M.E.P.} = 71.1 \times .85 = 60.4 \text{ lbs.}$$

Therefore, since

$$\text{I.h.p.} = \frac{pLan}{33,000} \quad a = \frac{75 \times 33,000}{60.4 \times 600} = 68.3 \text{ sq.in.}$$

$$d = 9\frac{1}{2} \text{ ins. (approx.);}$$

and since $2Ln = 600$, assume $L = 1 \text{ ft.}$

hence $n = 300 \text{ R.P.M.}$

The engine is rated $9.5 \times 12 \text{ ins.}$, running at 300 R.P.M.

67. Determination of Clearance Volume from Diagram.

It was shown in a preceding paragraph that the clearance volume of a cylinder must be known in order to draw the line of zero volumes on the indicator diagram. This volume can be determined accurately for any real engine by weighing the quantity of water required to fill the clearance space, but this procedure is often impossible and an alternative, though approximate, method is often resorted to.

This method is graphical and depends upon the assumption of the law of expansion and compression. As in the case of the conventional diagrams, expansion and compression are assumed to follow rectangular hyperbolas.

It is a property of this curve that diagonals such as aa and bb drawn for rectangles with their corners on the

curve all pass through the origin of coordinates as shown in Fig. 79.

If two points a and c are selected on the expansion curve of a real diagram and a rectangle is drawn upon them as shown in Fig. 80, the diagonal bd extended will pass through the origin of coordinates, if the expansion follows the assumed law. The point at which this diagonal cuts the zero pressure line must therefore be the point through which the vertical line of zero volume is to be drawn.

If the original assumption were correct, this construction would give the same point when different locations of the points a and c were chosen and when used on the

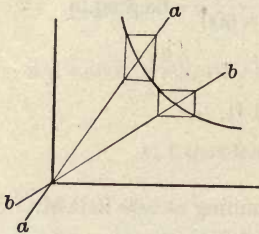

FIG. 79.—Rectangular Hyperbola.

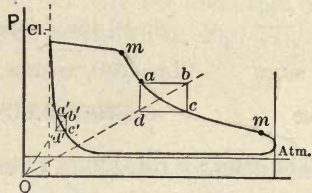

FIG. 80.

compression as well as on the expansion line. In reality it will generally give as many different locations for the origin as are chosen for the rectangle $abcd$. It is customary to construct this rectangle of fair size and to locate it near the center of the expansion curve.

68. Diagram Water Rate. As was shown in an earlier chapter, part of the steam supplied an engine is generally condensed upon the cold metal walls surrounding it. The indicator diagram therefore shows the volumes assumed by the mixture of steam and liquid water in the cylinder, but, since the volume occupied by the liquid is negligible, it may be assumed to show the volumes occupied by the part of the mixture which exists in vaporous form.

Assuming that the vapor is saturated, the volume occupied by one pound at various pressures can be found from the steam tables and, therefore, the weight existing in the cylinder can be calculated. The weight of steam determined in this way is known as the **indicated steam**, the **diagram steam** or the **diagram water rate**.

The diagram water rate is generally determined for a point such as z in Fig. 81 just after cut-off, though some engineers prefer to use a point nearer the lower end of the expansion curve. The volume occupied by the steam contained in the cylinder at point z is equal to V_z and its weight can be determined by dividing this volume by the specific volume V_z for the existing pressure P_z . Thus, calling the weight of steam in the cylinder w_z ,

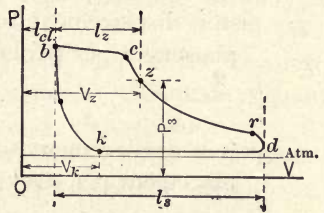

FIG. 81.

Thus, calling the weight of steam in the cylinder w_z ,

$$w_z = \frac{V_z}{V_z} \dots \dots \dots (51)$$

This quantity of steam is a mixture of cylinder feed and clearance or cushion steam and the weight of the latter must therefore be subtracted from w_z to obtain the weight of cylinder feed w_f . Assuming the cushion steam dry and saturated at the point k , the weight of cushion steam is

$$w_k = \frac{V_k}{V_k}, \dots \dots \dots (52)$$

so that the weight of cylinder feed per cycle as shown by the diagram at the point z is

$$w_f = w_z - w_k = \frac{V_z}{V_z} - \frac{V_k}{V_k} \dots \dots \dots (53)$$

The formula is generally modified to give the steam consumption per indicated horse-power hour, instead of

per cycle, and it is also expressed in different terms as a matter of convenience.

For this purpose let

y_{cl} = clearance volume divided by piston displacement per stroke

$$= \frac{l_{cl}}{l_s};$$

y_z = piston displacement to point z divided by piston displacement per stroke

$$= \frac{l_z}{l_s};$$

y_k = piston displacement to point k divided by piston displacement per stroke

$$= \frac{l_k}{l_s};$$

a = area of piston in square inches;

p = mean effective pressure in pounds per square inch;

L = stroke in feet; and

n = number of cycles per minute.

The piston displacement is then $\frac{a}{144}L$ cubic feet and the volumes at z and k are given by

$$V_z = \left(y_z \times \frac{aL}{144} \right) + \left(y_{cl} \times \frac{aL}{144} \right),$$

and

$$V_k = \left(y_k \times \frac{aL}{144} \right) + \left(y_{cl} \times \frac{aL}{144} \right).$$

Substituting these values in Eq. (53) gives the cylinder feed per cycle as

$$w_f = \frac{aL}{144} \left(\frac{y + y_{cl}}{V_z} - \frac{y_k + y_{cl}}{V_k} \right). \quad \dots \quad (54)$$

Multiplying by the number of cycles per hour ($60 \times n$) and dividing by the indicated horse-power, $\frac{pLan}{33,000}$, gives

the diagram water rate, or steam shown by the diagram per I.h.p. hour as

$$w_a = \frac{13,750}{p} \left(\frac{y_z + y_{cl}}{V_z} - \frac{y_k + y_{cl}}{V_k} \right), \quad \dots \quad (55)$$

in which form the equation involves only values which can be determined directly from the diagram without any knowledge of the engine dimensions.

The value obtained for w_a will vary as the location of points z and k are varied because of the quality changes occurring during expansion and compression, and it is obvious that the diagram water rate is in no sense an accurate measure of the *real* water rate of the engine. It is, however, very useful for comparison with the real water rate, the ratio giving an indication of the loss by condensation.

Average values for real water rates are given in Chapter XI.

ILLUSTRATIVE PROBLEM

Given the diagram shown in Fig. 82 and the following data from an actual test, find the diagram water rate for point c , and for point n . Double-acting steam engine having:

Average piston area = 28.9 sq.-in.;

Length of stroke = 8 in.;

R.P.M. = 237; I.h.p. = 8.75;

M.E.P. = 31.6 lbs.;

Clearance = 13%; Beginning of compression = 29%;

Weight of condensate per hour = 371 lbs.;

Quality at throttle = 95%;

Sp. vol. at c = 7.8;

Sp. vol. at n = 12.57;

Sp. vol. at K = 38.4 cu.ft. per lb.;

Assume x_k = 100%.

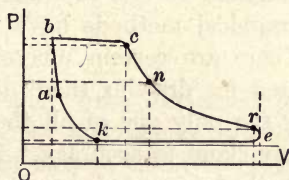

FIG. 82.

Solution. Substitution in Eq. (55) gives

$$\begin{aligned}(W_a)_c &= \frac{13,750}{p} \left(\frac{y_c + y_{cl}}{V_c} - \frac{y_k + y_{cl}}{V_k} \right) \\ &= \frac{13,750}{31.6} \left(\frac{0.39 + 0.13}{7.8} - \frac{0.29 + 0.13}{38.4} \right) \\ &= 24.2 \text{ lbs. per I.h.p. per hour at point } c.\end{aligned}$$

$$\begin{aligned}(W_a)_n &= \frac{13,750}{31.6} \left(\frac{y_n + y_{cl}}{V_n} - \frac{y_k + y_{cl}}{V_k} \right) \\ &= \frac{13,750}{31.6} \left(\frac{0.638 + 0.13}{12.57} - \frac{0.29 + 0.13}{38.4} \right) \\ &= 21.83 \text{ lbs. per I.h.p. per hour at point } n.\end{aligned}$$

$$\text{Real water rate} = \frac{371}{8.75} \times 0.95 = 40.2 \text{ lbs.}$$

69. $T\phi$ -diagram for a Real Engine. In Chapter VI the $T\phi$ -diagrams of the various ideal cycles were given and attention was called to the fact that these diagrams were particularly useful, because they showed certain things which were not apparent from the more common PV -diagrams.

It has been customary for many years to draw $T\phi$ -diagrams for real engines by "transferring" the PV -diagram to $T\phi$ -coordinates, and various analytical and graphical methods have been developed for this purpose. There are certain unavoidable errors in all the methods used for drawing these diagrams, and the expansion curve is the only one of all the lines finally obtained which has any claim to accuracy. Even this curve is generally incorrectly interpreted, because a knowledge of the exact weight of clearance steam is necessary for an accurate interpretation and such knowledge is never available.

Under the circumstances it seems unnecessary to consider in this book the rather complicated details involved in the construction of $T\phi$ -diagrams purporting to show the behavior of steam in real engines.

70. Mechanical and Thermal Efficiencies. The method of obtaining the indicated horse-power from the indicator diagram has been given in preceding paragraphs. In the real engine this power is not all made available at the shaft, because some of it is used in driving the engine against its own frictional resistance. Calling the power lost in this way the **friction horse-power**, it follows that

$$\text{I.h.p.} = \text{F.h.p.} + \text{D.h.p.}, \quad \quad (56)$$

in which

I.h.p. = indicated horse-power determined from the real indicator diagram;

F.h.p. = friction horse-power, i.e., power required to drive engine; and

D.h.p. = developed horse-power, i.e., power made available at shaft.

The **developed horse-power** is therefore always less than the indicated horse-power. The better the construction of the engine the smaller the friction loss, and the measure of this loss is usually given in the form of an efficiency. It is called the **mechanical efficiency**, and is defined by the equation

$$\text{Mech. eff.} = \frac{\text{D.h.p.}}{\text{I.h.p.}} \quad (57)$$

Values of mechanical efficiency range from about 80 per cent in the case of poorly designed and poorly adjusted horizontal engines to about 95 per cent in the case of the best vertical designs.

The efficiency determined by dividing energy made available by heat supplied is known as the **thermal efficiency**. There are two possible thermal efficiencies, one based on the indicated power and the other on the developed power. The former is called the *thermal efficiency on the indicated horse-power* or the *indicated thermal efficiency*; the other

is known as the *thermal efficiency on the developed horsepower* or the *developed thermal efficiency*. Obviously

$$\text{Dev. ther. eff.} = \text{Mech. eff.} \times \text{Indic. ther. eff.} \quad . \quad . \quad (58)$$

The heat supplied may be assumed in two different ways; it may be taken as the total heat above 32° F. in the steam supplied the engine, or it may be taken as this value less the heat of the liquid corresponding to exhaust temperature. The second method is preferable, since it is reasonable to assume that the exhaust steam can be condensed to water at the same temperature and that this water can be pumped to the boiler with the heat of the liquid corresponding to this temperature. This is practically parallel to the assumption made in treating the theoretical cycles.

The thermal efficiencies are then

Indic. ther. eff.

$$= \frac{\text{I.h.p.} \times 2545}{\text{Heat above exhaust temp. supplied per hour}} \quad . \quad (59)$$

and

Dev. ther. eff.

$$= \frac{\text{D.h.p.} \times 2545}{\text{Heat above exhaust temp. supplied per hour}} \quad . \quad (60)$$

Values of the indicated thermal efficiency range from about 5 per cent in ordinary practice with small engines to about 25 per cent in the best large engines. Values as low as 1 per cent are not uncommon with small, poorly designed and poorly operated engines.

The actual performance of the cylinder of an engine is sometimes compared with the ideal possibilities as indicated by the Clausius and the Rankine cycles. The ratio of the work obtained in the real engine to that which could be obtained from the same quantity of heat with a Rankine

or Clausius cycle is a measure of the performance of the real cylinder. This ratio is variously designated as *cylinder efficiency*, *indicated efficiency*, *relative efficiency*, etc. Its values range from less than 40 per cent to over 80 per cent, the highest recorded value being just over 88 per cent.

PROBLEMS

1. Using Table I, Chapter I, plot the specific heat of water between the range of temperatures of 20° F. and 300° F. for the intermediate values given. By the ordinate method for finding the mean height of an indicator diagram, determine the mean or average specific heat over this range.

2. A double-acting engine is required to give 50 I.h.p. under the following conditions:

Cut-off = 25%;

Steam pressure = 150 lbs. per square inch absolute;

Back pressure = 16 lbs. per square inch absolute;

Piston speed = 540 ft. per minute.

If the diagram factor for this type of engine is 75%, find the diameter of the cylinder and select the stroke and R.P.M.

3. Assume a single-acting engine with 10-in. diameter and 12-in. stroke, 10×12 ins., to have cut-off occur at various points between 10% and 50% of stroke. Assume also the pressures, speed, and card factor as given in Prob. 2. Find the probable I.h.p. at different cut-offs.

4. Given an 18×24-in. engine running at 120 R.P.M.

Back pressure = 2 lbs. per square inch absolute;

Clearance = 10%;

Cut-off = 40%;

Diagram factor = 85%.

Supposing cut-off to remain constant, find the I.h.p.'s corresponding to steam pressure of 50, 90, and 130 lbs. per square inch absolute.

5. Find the weight of dry steam which must be supplied per I.h.p. hour for each case of the previous problem, assuming the quality at cut-off to be 80%. Assume compression pressure to be 30 lbs. absolute and that steam is dry and saturated at end of compression.

6. Find the quality of steam at cut-off in a cylinder, in which the piston displacement is 0.1278 cu.ft.; clearance = 10%; cut-off at 25% stroke; steam pressure at cut-off, 115 lbs. per square

inch absolute, and weight of steam in the cylinder at cut-off = 0.012 lb.

Note. $\text{Quality} = \frac{\text{Actual vol.}}{\text{Weight} \times \text{Sp. vol.}}$ for the given pressure.

7. The piston displacement of a certain engine is 0.2 cu.ft. What weight of steam is in the cylinder at release where quality is 90%, and pressure is 25 lbs. per square inch absolute, if the clearance is 10%, and release occurs at 95% of the stroke?

8. Find the weight of cushion steam in a 6×6 in. engine in which clearance = 15%; compression begins at 85% of the return stroke; back pressure is 14.7 lbs. per square inch absolute, and the quality of the cushion steam at the beginning of compression is 95%.

9. Find the pressure and quality at the end of the compression line of the previous problem, assuming it to be adiabatic.

10. An 8×10 in. engine running at 300 R.P.M. is double-acting, and cuts off at 15% of the stroke at a pressure of 120 lbs. per square inch absolute. It has a steam consumption of 35 lbs. per I.h.p.-hour. The compression begins at 60% of the return stroke with a quality of unity and a back pressure of 5 lbs. per square inch absolute. Clearance = 10%.

If this engine delivers 27 H.P., and has a mechanical efficiency of 90%, what is the quality at the point of cut-off?

11. In the previous problem, assume release to occur at 90% of the stroke with an absolute pressure of 30 lbs. per square inch. What is the quality at this point?

12. A certain engine gives one horse-power hour at the shaft for every 20 lbs. of steam supplied. The steam has an initial pressure of 150 lbs. absolute and is dry and saturated when it arrives at the engine. The back pressure against which steam is exhausted is 4 lbs. absolute.

(a) Find the thermal efficiency of this engine on the developed or shaft horse-power.

(b) If the mechanical efficiency of the engine is 90%, what is the value of the thermal efficiency on the indicated horse-power?

CHAPTER IX

COMPOUNDING

71. Gain by Expansion. The cycle which gives a rectangular PV -diagram is the least economical of all the ideal cycles described in Chapter IV. This comes from the fact that none of the heat stored in the steam is converted into work when this cycle is used. Thus, if the cylinder shown by full lines in Fig. 83 operate on this cycle and be of such size that it will receive just one pound of steam per cycle, it makes available an amount of work represented by the area $abcd$. The positive work done by the steam upon the piston is the equivalent of the external latent heat of vaporization while no use is made of the heat stored in the steam. This stored heat is removed *as heat* during the condensation and exhaust, which give the lines bc and cd .

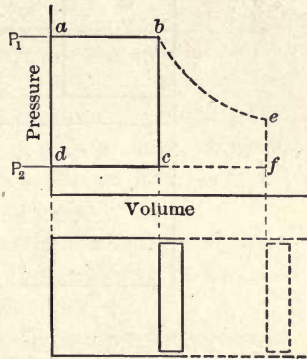

FIG. 83.

If a piece be added to the cylinder as indicated by the dotted lines, the same quantity of steam will make more heat available by expanding after cut-off, as shown by the curve be , the net work in this case being represented by the area $abefd$ instead of by the smaller area $abcd$. But the heat supplied is the same in both cases, namely that required to form one pound of steam at the pressure P_1 , so that the use of a large cylinder and the incomplete ex-

pansion cycle results in the development of more work than can be obtained with the rectangular cycle from the same amount of heat.

Obviously it would be theoretically advantageous to add still more to the length of the cylinder and allow the expansion to continue to back pressure, giving the complete expansion cycle as shown in Fig. 84, thus obtaining the maximum quantity of work at the expense of the heat stored in the steam supplied the cylinder. Practically, it is found inadvisable to continue the expansion to such a de-

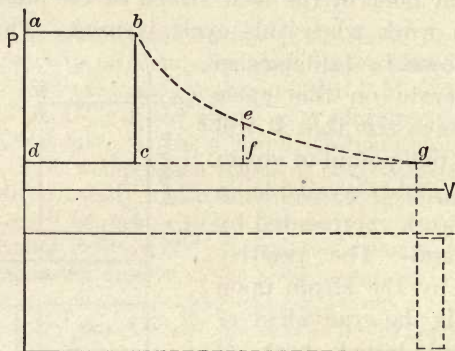

FIG. 84.

gree in reciprocating steam engines, because at low pressures the volume increases very rapidly for small pressure drops. Thus a great increase is necessary in the size of the cylinder if the last part of the expansion is to be completed, but the amount of work obtained is comparatively small, as shown by the small height of the long toe thus added to the diagram. This may result in an actual loss, because the increased friction losses of the very large cylinder may more than balance the small increase of net work gained by its use. It thus results that, in every real reciprocating engine, there is some point beyond which it is not economical to carry the expansion, and the incomplete expansion

cycle is therefore approximated in such engines rather than the cycle with complete expansion.

Viewing the matter from another angle, a cylinder of a certain size may be assumed as shown in Fig. 85. The use of the rectangular cycle $abcd$ in this cylinder will make available the maximum quantity of work possible with the upper and lower pressures chosen. If cut-off be made to occur earlier as at b' , the expansion $b'c'$ will result in a loss of the quantity of work obtained, as shown by the area $b'bc'$, but the steam used per horse-power will be less,

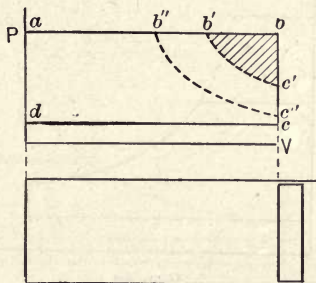

FIG. 85.

so that there will be a gain in steam economy. Putting the cut-off still earlier will cause a still greater loss of work obtained from a cylinder of the chosen size, but theoretically will result in greater economy of steam.

Summing up, it may be said that the greater the ratio of expansion the greater should be the economy in the use of steam on a theoretical basis.

The lower pressure is set in real engines by the pressure in the space into which the engine is to exhaust. If the engine is to be operated non-condensing, the atmospheric pressure determines the lowest possible exhaust pressure; if the engine is to be operated condensing, the exhaust pressure is set by the lowest pressure which can be economically maintained in the condenser.

There is thus a real limit to the extent to which expansion can be carried in any real engine with a given initial pressure. A certain drop must exist at the end of the diagram, for reasons already explained, and an expansion line drawn backward from the top of the line representing this drop will give the earliest possible cut-off

which can be used in the engine with a given initial pressure.

The ratio of expansion can be further increased, however, by raising the initial pressure as indicated by the

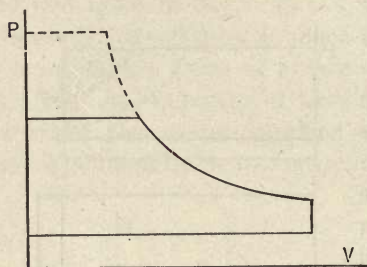

FIG. 86.

dotted lines in Fig. 86, and the limit in this direction would come with the inability of materials of construction to withstand the resulting strains.

These conclusions drawn from the facts developed above must all be modified in the case of real engines, because of

the effect of cylinder condensation. This has been shown to increase as the cut-off is made earlier and as the pressure (and therefore the temperature) range in a cylinder is increased. There is, therefore, a limit beyond which it is not advisable to carry the ratio of expansion in a single cylinder.

Experience has shown that the best commercial results are obtained from simple engines, that is, those expanding the steam entirely in one cylinder, when (a) they are operated non-condensing, (b) the initial pressure is between 80 and 100 pounds per square inch for the simpler forms of valves and up to 125 lbs. with the better forms of valves, and (c) the point of cut-off is at about $\frac{1}{4}$ stroke with the simpler valves and at from $\frac{1}{6}$ to $\frac{1}{4}$ stroke with the better forms of valves. These values of cut-off correspond to nominal expansion ratios of 5 and 4 respectively and to lower values when clearance is taken into account.

72. Compounding. If the ratio of expansion is to be increased above the values just given, some means must be used for the reduction of loss by condensation. This loss can be reduced by decreasing the surface exposed to

high-temperature steam and by decreasing the temperature range in a cylinder. Both of these results can be achieved by what is known as **compounding**.

Assume that it is deemed advisable to produce a cycle similar to that shown in Fig. 87 (clearance neglected) and that in order to obtain

high steam economy (low water rate) the ratio of expansion chosen is very much greater than four. No gain in economy would result from such excessive expansion in a single cylinder, in fact there would be a well-defined, unavoidable loss. But suppose that the high-pressure steam is admitted to a small cylinder such as that shown and is expanded to the point f , is then exhausted as shown by fg into the larger cylinder along gf and then expanded to the point c in the larger cylinder. The cycle produced is the same as that which would have been obtained by expanding entirely in one cylinder, but the surface of the clearance space of the high-pressure (H.P.) cylinder, which is exposed to high-pressure steam is smaller than it would be in a cylinder of the size required to hold the steam when fully expanded and, moreover, the lowest temperature to which it is subjected is that corresponding to the pressure at f instead of the much lower temperature corresponding to the pressure at d .

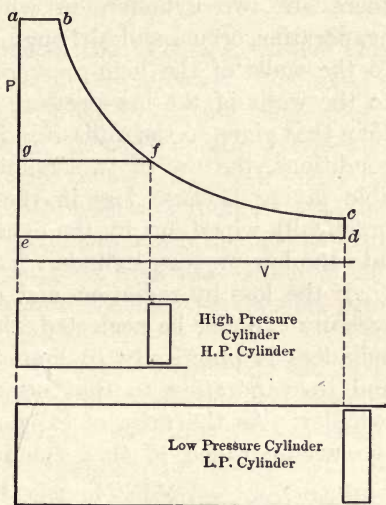

FIG. 87.

high-pressure steam is admitted to a small cylinder such as that shown and is expanded to the point f , is then exhausted as shown by fg into the larger cylinder along gf and then expanded to the point c in the larger cylinder. The cycle produced is the same as that which would have been obtained by expanding entirely in one cylinder, but the surface of the clearance space of the high-pressure (H.P.) cylinder, which is exposed to high-pressure steam is smaller than it would be in a cylinder of the size required to hold the steam when fully expanded and, moreover, the lowest temperature to which it is subjected is that corresponding to the pressure at f instead of the much lower temperature corresponding to the pressure at d .

The condensation which would occur in the H.P. cylinder would obviously be less than that which would result from

the use of one large cylinder and, remembering that the greater part of the heat given up during condensation is received again by the steam during exhaust, it is obvious that approximately this same quantity of heat can again be given to the low-pressure cylinder walls. Thus, although there are two cylinders in which condensation and re-evaporation occur, and although the sum of the heat given to the walls of the high-pressure cylinder and that given to the walls of the low-pressure cylinder might be greater than that given to the walls of a single cylinder under similar conditions, the use of two cylinders results in a considerable saving because loss in the high-pressure cylinder is practically wiped out by the exhaust of the heat concerned into the low-pressure cylinder.

If the loss by radiation and conduction from the high-pressure cylinder be neglected, the result of the use of two cylinders is practically to limit the loss by condensation and re-evaporation to that occurring in the low-pressure cylinder. As the ratio of expansion in this cylinder is in the neighborhood of that common in simple engines, or

even less, and as the temperature range is small, the net loss is also small.

It is obvious that the smaller the surface of the high-pressure cylinder can be made, and the smaller the temperature range in a single cylinder, the smaller will be the net loss by cylinder condensation and re-evaporation. A

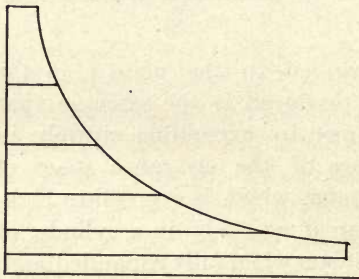

FIG. 88.

saving should therefore be effected by using more than two cylinders, and it is not inconceivable that five or more might be used. The result of using five cylinders is shown in Fig. 88, and it is evident that the clearance surfaces exposed to

high temperatures, the temperature ranges per cylinder and the ratios of expansion per cylinder are all small. The gain in economy should therefore be correspondingly great.

There are *two limits to the possible multiplication of cylinders* in this way.

(1) As the number increases the radiating surface and therefore the heat lost by radiation increases. The extent of this effect can be appreciated by noting that every cylinder with the exception of the low-pressure cylinder is really an unnecessary addition, because the cycle could be produced entirely in the low-pressure cylinder. On the other hand, the surfaces of cylinders which operate at high temperature are small as compared with that which would be exposed to this temperature if the entire cycle were produced in the low-pressure cylinder.

(2) As the number of cylinders is increased, the first cost, the complexity and the cost of lubrication and attendance are all increased so that, for each installation, some number will be found beyond which the interest on the investment and the added cost of operation and maintenance would more than balance the saving of fuel.

The second limit mentioned is the more important commercially, as it is the first one reached. For ordinary operating conditions in stationary power plants expansion in two cylinders generally gives the most economical results. The total ratio of expansion is generally between 7 and 16, that is, the volume of steam at release in the L.P. cylinder is from 7 to 16 times the volume at cut-off in the H.P. cylinder. For large pumping stations and large marine installations, expansion in three cylinders is generally considered the most economical, and total ratios of expansion of 20 or more are used. Four and five cylinders have been used, but the resultant gains do not seem to warrant any extensive installation of such units.

Engines using more than one cylinder for the expansion

of steam in the way just described are called **multi-expansion engines**, or **compound engines**, and the use of multi-expansion is spoken of as **compounding**. Custom has almost confined the use of the term compound engine to those in which only two cylinders are used in series as indicated in Fig. 89, and such engines are often spoken of as *2x* engines.

Engines in which three cylinders are used in series are called *triple-expansion* or *3x* engines. With four and five cylinders in series the engines are known as *quadruple* or *4x* and *quintuple* or *5x*, respectively.

In the case of triple-expansion engines of large size,

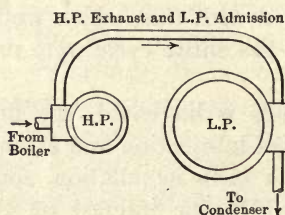

FIG. 89.

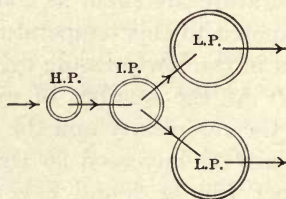

FIG. 90.

the volume of the low-pressure cylinder required generally becomes so great that it is found economical to use two low-pressure cylinders instead of one. The flow of steam in such an engine is represented diagrammatically in Fig. 90. This type is known as a *four-cylinder, triple-expansion engine*.

All multi-expansion engines are generally operated condensing, and the choice of type is determined partly by the character of work to be done and partly by economical considerations. In all cases the boiler pressure must be chosen to suit the type of engine used. The pressures ordinarily used with the different types are given in Table V.

TABLE V
BOILER PRESSURE COMMONLY USED

Type of Engine.	Boiler Pressure. Pounds per Sq.in. Gauge.
Simple.....	80 to 125
High-speed compound.....	100 to 170
Low-speed compound.....	125 to 200
Triple expansion and higher.....	125 to 225

73. The Compound Engine. The term compound engine will be used hereafter in the commercial way as referring to a $2x$ engine. Such engines may roughly be divided into two types, *receiver* and *non-receiver* engines. The latter are often called Woolf engines, after the man who first used this construction.

A **receiver engine** has a vessel known as a receiver located between the two cylinders and so connected with them that the high-pressure cylinder exhausts into the receiver and the low-pressure cylinder draws its steam from the receiver. By using a receiver the cylinders are made independent of each other so far as steam events are concerned; the high-pressure cylinder can exhaust at any time with reference to the events occurring in the low-pressure cylinder.

A **Woolf type** has practically no receiver, the high-pressure cylinder exhausting directly into the low-pressure cylinder through the shortest convenient connecting passage. As the high-pressure cylinder must exhaust directly into the low-pressure cylinder it follows that cut-off must not occur in the latter until compression starts in the former; i.e., very near the end of the stroke.

An engine with a receiver of infinite size would give a horizontal exhaust line for the high-pressure cylinder and a horizontal admission line for the low-pressure cylinder, since the small amount of steam given to or taken from the

receiver would have no appreciable effect upon the pressure within that vessel. Neglecting throttling losses, the high-pressure and low-pressure cards would therefore fit together as originally indicated in Fig. 86.

With receivers of finite size there are pressure changes during exhaust by the high- and admission to the low-pressure cylinders, and real valves and connections also cause certain throttling losses, so that the lines representing these events are not horizontal nor do they exactly coincide.

A diagrammatic arrangement of the Woolf engine is given in Fig. 91 with idealized diagrams obtained by

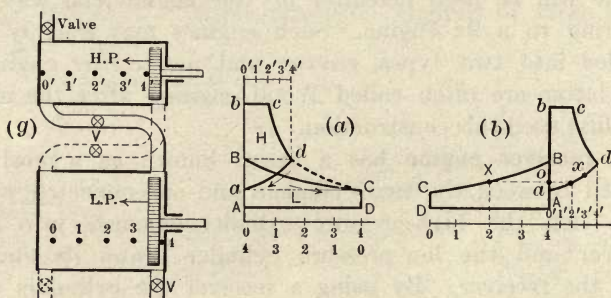

FIG. 91.

assuming hyperbolic expansions, no clearances, and no throttling losses. The pistons must make their strokes together in such engines, but they may move in the same direction, as shown in the figure, or in opposite directions.

The ideal diagram would be that shown at (a) by the lines $abcdCDA$. The idealized high-pressure diagram is $abcd$ and the idealized low-pressure diagram is $ABCD$. The exhaust line da of the high-pressure diagram and the admission line BC of the low-pressure diagram are produced at the same time. Corresponding points on these two lines represent the common pressures assumed by the steam not yet exhausted from the high-pressure cylinder, the steam in the small connecting passage and the steam

already admitted to the low-pressure cylinder. As the movement of the low-pressure piston opens up volume faster than the high-pressure piston closes up volume, the volume occupied by the steam continues to increase as the low-pressure piston moves out, and its pressure therefore decreases.

The two diagrams are shown back to back at (b) in the figure and the horizontal line xX connects corresponding

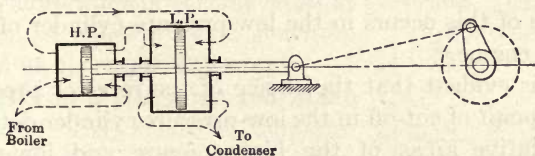

FIG. 92.

points on the exhaust of the high pressure and the admission of the low pressure.

Compound engines are also divided into two types on the basis of cylinder arrangement. When the axes of both cylinders coincide as shown in Fig. 92 they are called **tandem compounds**. When the axes are parallel as shown in Fig. 89, the engines are spoken of as **cross-compound engines**.

74. Cylinder Ratios. The idealized diagrams of a compound engine with infinite receiver volume are shown in Fig. 93 by $abcd$ and $ABCDE$. The height of the high-pressure exhaust line is the same as that of the low-pressure admission line and represents the receiver pressure p_R . The value of the receiver pressure is determined

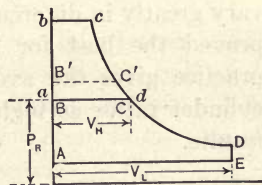

FIG. 93.

by the point chosen for cut-off in the low-pressure cylinder. Thus if cut-off in the low-pressure cylinder is made to occur earlier, as at some point c' , the admission line for this

cylinder must move up to $B'C'$ and the receiver pressure must rise correspondingly. The exhaust pressure in the high-pressure cylinder would also rise an equal amount.

Changing the point of cut-off in the low-pressure cylinder also produces another result. As the receiver pressure rises the work area of the high-pressure diagram is obviously decreased, while that of the low-pressure diagram is increased. In a simple engine the area of the diagram becomes smaller the earlier the cut-off, and it should be noted that just the reverse of this occurs in the low-pressure cylinder of a compound engine.

It is evident that the choice of the receiver pressure or of the point of cut-off in the low-pressure cylinder determines the relative areas of the high-pressure and low-pressure diagrams and it also determines the relative size of the two cylinders. The diagram of Fig. 93 shows that late cut-off in the low-pressure cylinder calls for a larger high-pressure cylinder than does early cut-off.

The ratio of the piston displacement of the low-pressure cylinder to that of the high-pressure cylinder is called the cylinder ratio. Designating this ratio by R , and using other symbols as in Fig. 93,

$$R = \frac{V_L}{V_H} \dots \dots \dots (61)$$

The cylinder ratios chosen for real compound engines vary greatly in different designs and no given ratio has been proved the best for a given set of conditions. Normal practice gives the average values listed in Table VI, but cylinder ratios as high as 7 have been used with excellent results.

TABLE VI
CYLINDER RATIOS FOR COMPOUND ENGINES

Cylinder ratio.....	2½	3¼	4	4½
Initial pressure (gauge) non-condensing.....	100	120		
Initial pressure (gauge) condensing.....	100	120	150

The cylinder ratio to be used in a given case may be determined by any one of several considerations or by a combination of them, the latter being more often the case. Thus it may be deemed desirable to obtain the same amount of work from both cylinders; or to obtain equal temperature ranges; or to have cut-offs occur at the same fraction of the strokes; or to have the same total load on the two piston rods during admission; or to obtain the maximum possible uniformity of turning effort at the crank. The consideration of equal work is generally regarded as the most important.

75. Indicator Diagrams and Mean Pressures. The idealized diagrams for a compound engine with clearance, with incomplete expansion in both cylinders, and without compression are given in Fig. 94. The nominal

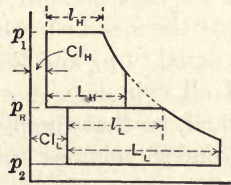

FIG. 94.

total ratio of expansion would be $L_L \div l_H$, but the total ratio of expansion taking account of clearance is

$$\text{Total ratio of expansion} = \frac{L_L + Cl_L}{l_H + Cl_H}, \quad \dots \quad (62)$$

and the cylinder ratio is

$$R = \frac{L_L}{L_H} \dots \dots \dots (63)$$

The mean effective pressures can be found from each of the diagrams in the ordinary way and the indicated horse-power of each cylinder determined therefrom. *The indicated horse-power of the engine is then equal to the sum of the values obtained for the separate cylinders.*

It is often convenient to refer the mean effective pressure of all cylinders to the low-pressure cylinder as though this were the only cylinder acting. In the simple form of diagram, such as that shown in Fig. 93, it is obvious that this could be obtained by measuring the area *AbcDEA*,

dividing by the length AE and multiplying by the scale of the spring, just as though the diagram were all produced in one cylinder with the piston displacement equal to V_L . In the case of the diagrams given in Fig. 94 a similar method could be adopted, or the mean effective pressure of each cylinder could be determined separately and then the equivalent pressure which would give the same result on the low-pressure piston could be determined analytically.

Assume for this purpose that the mean effective pressure of the high-pressure is equal to p_H pounds per square inch, that the mean effective pressure of the low-pressure cylinder is equal to p_L and that the cylinder ratio is R . The strokes of all cylinders of a multi-expansion engine are generally equal, so that the piston areas are in the same ratio as the cylinder volumes (piston displacements). In the case of a $2x$ engine, therefore, the area of the low-pressure piston is R times as great as that of the high-pressure piston, and the pressure required on the low-pressure piston to do the same work as that done by pressure p_H on the high-pressure piston will be $\frac{p_H}{R}$.

In the case of a $2x$ engine therefore the total M.E.P. referred to the low-pressure cylinder is

$$p_R = \frac{p_H}{R} + p_L \quad \dots \dots \dots (64)$$

This mean effective pressure acting on the low-pressure piston only would give the same indicated horse-power as is obtained with the two cylinders of the engine.

In designing compound engines it is customary to determine the size of the low-pressure cylinder as though it were to do all the work expected of the engine by receiving steam at the highest pressure available and exhausting it at the lowest. The mean effective pressure which would thus be assumed to exist is the referred value p_R just explained. Having found the size of the low-pressure cylinder,

and the value of the referred M.E.P. the size of the high-pressure cylinder can be determined so that the work done by each cylinder will be just half of the total for which the engine is being designed. This size will have to be such that the high-pressure mean effective pressure referred to the low-pressure cylinder (i.e., $p_H \div R$) is equal to half the total mean effective pressure referred to that cylinder. That is, the size will have to be so chosen that

$$\frac{p_H}{R} = \frac{p_r}{2} \dots \dots \dots (65)$$

ILLUSTRATIVE PROBLEM

A double-acting compound engine is capable of developing 500 I.h.p. The stroke is 18 ins.; revolutions per minute, 175; mean effective pressure referred to L.P. piston, 45 lbs. per square inch; cylinder ratio, $3\frac{1}{2}$. Find cylinder diameters.

From

$$I.h.p. = \frac{pLan}{33,000}$$

$$a_{L.P.} = \frac{500 \times 33,000}{45 \times 1.5 \times 175 \times 2}$$

so that

$$d_{L.P.} = \sqrt{\frac{700}{.785}} = 30 \text{ ins. (approx.)}$$

with the cylinder ratio equal to $3\frac{1}{2}$,

$$a_{H.P.} = \frac{700}{3.5} = 200 \text{ sq.ins.}$$

$$d_{H.P.} = \sqrt{\frac{200}{.785}} = 16 \text{ ins. (approx.)}$$

76. Combined Indicator Diagrams. When a compound engine is indicated, the diagrams of the two cylinders as drawn by the indicator are not directly comparable. The scales of pressure and volume are different on the two diagrams, and correction must be made for this fact before the

diagrams can be compared. It is customary to do this and to draw the average high-pressure and low-pressure diagrams on the same set of coordinates in order to determine how well they approximate the ideal diagram that would be obtained in one cylinder operating between the extreme limits of pressure.

Diagrams approximating those that would be obtained from high- and low-pressure cylinders are shown at (h) and (l) respectively, in Fig. 95, and the result of drawing

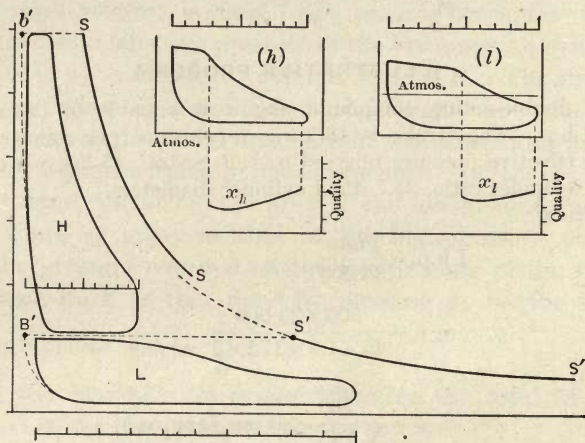

FIG. 95.

both to the same scales is shown at the left of this figure. The curves x_h and x_l show the variations of quality along the two expansion curves.

Drawing the two diagrams to the same scales in this way is known as combining the diagrams and the result is known as a **combined diagram**.

The curves SS and $S'S'$ added to the combined diagram are **saturation curves**. They do not, in general, form a continuous curve, because of the different quantities of steam contained in the two clearances and because any

moisture in the high-pressure exhaust is generally removed in the receiver. The volumes occupied by clearance steam at initial pressures are indicated by the points b' and B' respectively. The lengths $b'S$ and $B'S'$ approximately represent the volumes that would be occupied by cylinder feed when in each cylinder if dry and saturated.

A combined diagram for a triple-expansion engine is shown in Fig. 96. The heavy lines give diagrams constructed so as to represent as nearly as possible what may be expected to occur in the cylinders of such an engine, assuming perfect valve action and hyperbolic expansions and compressions. The dotted diagrams indicate the shapes that would be drawn by indicators applied to the real cylinders. The numerous sharp angles are due to overlapping of events, one cylinder suddenly starting to draw from a receiver while another is exhausting. It will be observed that the dotted diagrams do not contain any of these sharp angles, but that their general outline forms a fair average of them.

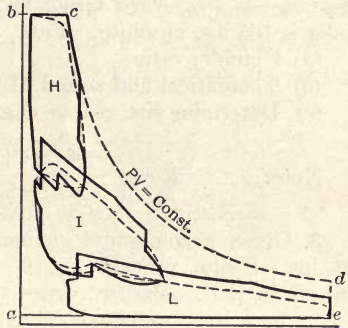

FIG. 96.

The curve cd is a rectangular hyperbola drawn as a continuation of the assumed hyperbolic expansion line of the high-pressure cylinder. The failure of the expansion lines of the other cylinders to fall upon this curve is explained by quality changes, different quantities of clearance steam in the different cylinders and withdrawal of moisture from steam exhausted to receiver before admission to the following cylinder.

PROBLEMS

1. Find the size of the cylinders of a double-acting compound engine, which is to give 600 I.h.p., when using steam at a pressure of 150 lbs. per square inch absolute, and having a back pressure of 2 lbs. per square inch absolute. The cylinder ratio is to be 4, and the total ratio of expansion 12, piston speed 750 ft. per minute, and R.P.M. = 150; diagram factor is 80%.

2. Given a 200 H.P. compound Corliss engine with cut-off in the H.P. cylinder at 60% stroke. Ratio of expansion is 7; clearance is 7%; card factor is 70%; pressure at the H.P. cylinder is 165 lbs. absolute. Find

- (a) Cylinder ratio; 4.38
 (b) Theoretical and actual M.E.P.;
 (c) Determine size of four engines, and select the best one.

Note.

$$R = \frac{1 + \% \text{ Cl}}{\% \text{ (C.O.)} + \% \text{ Cl}} \times \text{cyl. ratio.}$$

3. Given a compound engine 18×40 ins., having a stroke of 28 ins. Steam pressure is 165 lbs. per square inch absolute; cut-off in H.P. cylinder occurs at 62% stroke; clearance equals 16%; back pressure equals 5 lbs.; R.P.M. equal 150. Find

- (a) Cylinder ratio; 4.94 = 5
 (b) Ratio of expansion; 7.4
 (c) Actual M.E.P.; 61
 (d) I.h.p. 1620

CHAPTER X

THE D-SLIDE VALVE

77. Description and Method of Operation. The simple D-slide valve, shown in place in Fig. 97, is so named because of the similarity of its section to the letter D. It is located in the steam chest, rides back and forth upon its seat and

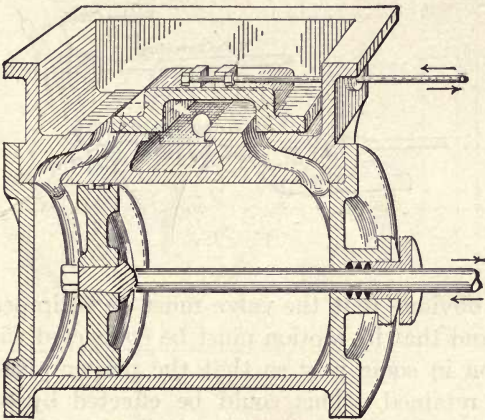

FIG. 97.

serves to connect the two ports alternately with steam and exhaust spaces respectively in order to give the necessary distribution of steam.

The valve has to perform the following functions for each end of the cylinder during each revolution of the engine:

- (1) It connects the proper port to the steam space or

steam chest at such a time that steam can enter the cylinder as the piston moves away from the head.

(2) It shuts off this port and thus cuts off the supply of steam when the piston has completed a certain definite fraction of the stroke.

(3) It connects the port with the exhaust cavity shortly before the piston reaches the end of the stroke, thus effecting "exhaust" or "release"; and

(4) It shuts off the port again when the piston has completed the proper fraction of the next stroke, thus trapping in the cylinder the steam which is compressed during the remainder of the stroke.

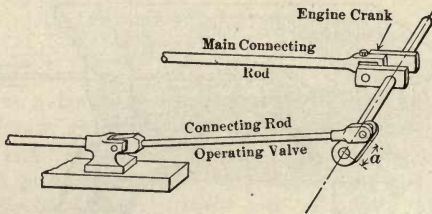

FIG. 93.

It is obvious that the valve must be reciprocated upon its seat and that its motion must be connected with that of the piston in some way so that the proper phase relation may be retained. This could be effected by the system shown diagrammatically in Fig. 98, a small crank operating on the end of a connecting rod giving the valve its short stroke just as the main crank fixes the longer stroke of the piston. Such an arrangement would, however, be very inconvenient with many real engines, as the valve would be located too far from the center line of the cylinder.

It is customary to use what is known as an **eccentric** for the purpose of operating the slide valve. The parts and arrangement of an eccentric, together with an illustration of the way in which it is mounted on the shaft of

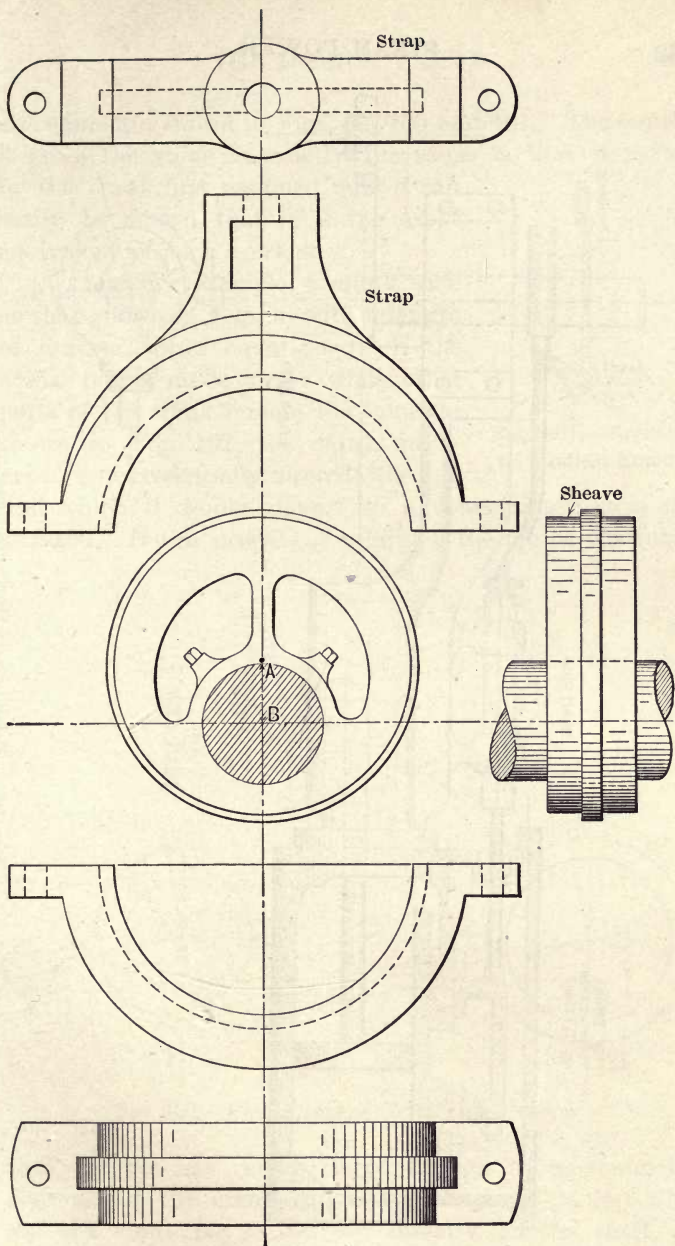

FIG. 99.—Parts of Eccentric.

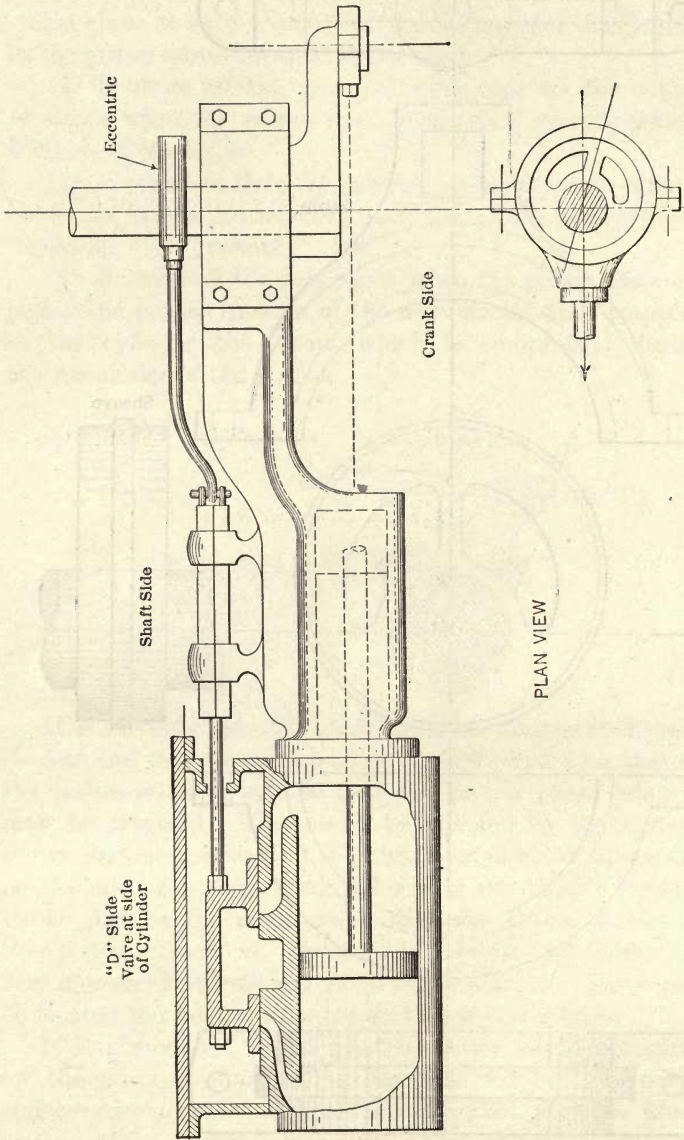

FIG. 100.—Eccentric on Horizontal Engine.

an engine are shown in Figs. 99, 100 and 101. The motion it gives the valve is exactly the same as that imparted by the crank first assumed, and it can easily be shown that it is the exact equivalent of such a crank.

Assume, for example, a crank such as that shown in Fig. 98 with a length of arm or throw equal to a . If the crank pin is made larger while other parts of the crank remain the same, as shown in Fig. 102, the crank mechanism is not essentially altered; the motion which it would impart to a connecting rod is not changed. If this process of enlarging the pin be continued

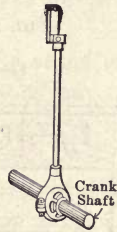

FIG. 101.—Eccentric on Vertical Engine.

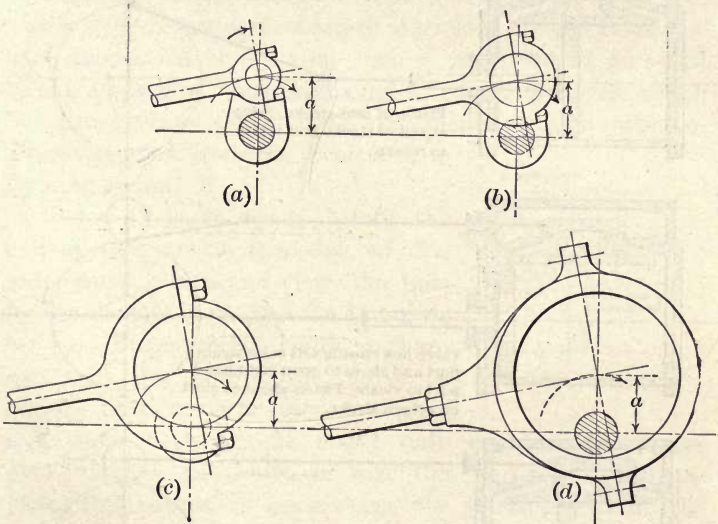

FIG. 102.—Equivalence of Crank and Eccentric.

until the pin has become large enough to surround the shaft and if the crank arm be then removed so that what was the crank pin is fastened directly on the shaft, an



FIG. 103.



FIG. 104.—Slide Valve without Lap.

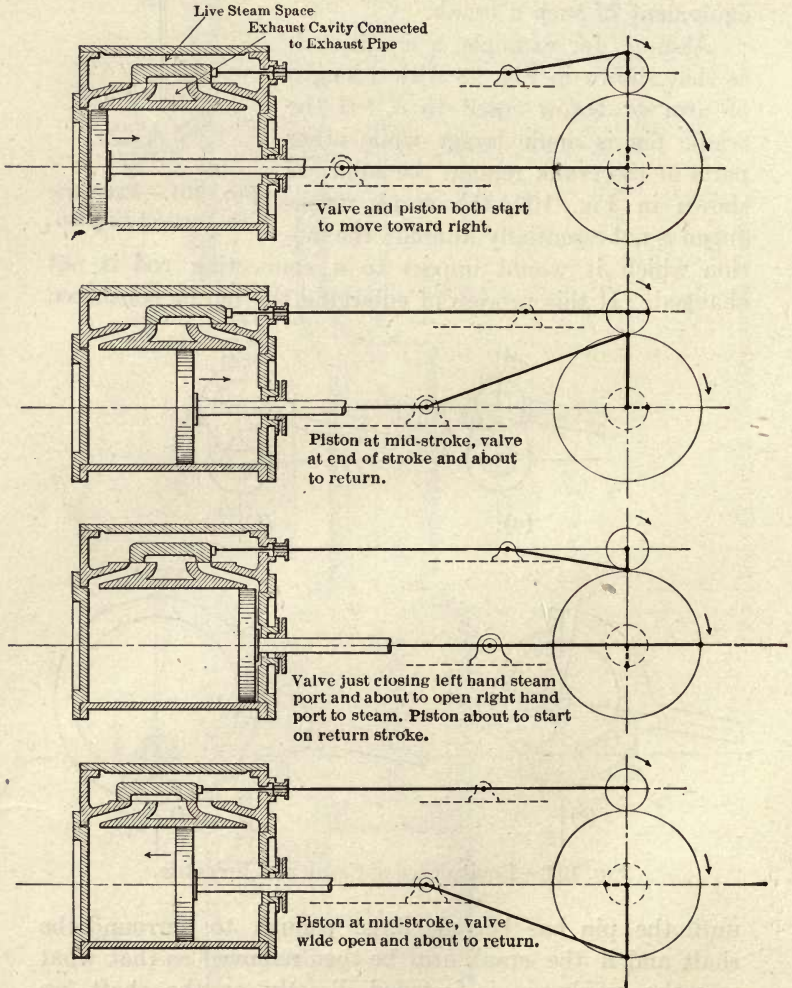

FIG. 105.

eccentric results. It is the exact equivalent of the original crank; its center, which is the center of the crank pin, revolves about the center line of the shaft in a circle with a radius a just as in the original mechanism.

The eccentric makes it possible to place a short crank (short arm) upon a large diameter shaft without having to cut the shaft away as shown in Fig. 103, and it is therefore very useful for driving valves.

78. Steam Lap. The simplest possible form of D-slide valve would just reach the outer edges of the ports when in its central position as shown in Fig. 104. The crank driving it (that is the crank equivalent to the eccentric which would probably be used in a real case) would have to be located 90° ahead of the engine crank in the direction of rotation, as can easily be seen by consulting Fig. 105, which illustrates the mechanism in various critical positions. The illustration shows that such a valve would give full stroke admission, thus producing a rectangular cycle which has already been shown to be very inefficient as a means of obtaining work from the heat used in forming steam.

If cut-off is to occur before the end of the stroke, the edge of the valve must return and close the port before the piston reaches the end of its stroke. But since the crank mechanism does not permit the valve to remain stationary in any one position, such early cut-off could only occur if the valve over-traveled, as shown in Fig. 106, and this would unfortunately result in connecting the working end of the cylinder to exhaust and in admitting steam to the other side of the piston at such a time as to oppose the piston's motion. The solution of the difficulty lies in making the valve longer, so that when in its central position it overlaps the outer edges of the ports as shown in Fig. 107.

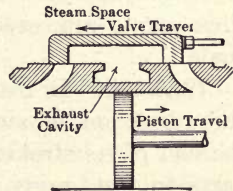

FIG. 106.

The amount of overlap of the outer edge is called the **outside lap**, and when steam is admitted by the outer edges of the valve, as in the case under discussion, it is also called the **steam lap**.

With such an arrangement the valve must be drawn out of its central position by the amount of the lap when the piston is at the end of its stroke as shown by a in Fig.

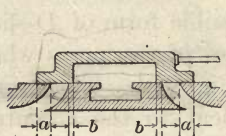

FIG. 107.—Steam and Exhaust Lap.

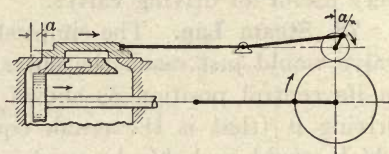

FIG. 108.—Lap a and Lap Angle α .

108 in order that steam may be admitted just as the piston starts to move. It follows that the crank driving the valve must be more than 90° ahead of the engine crank and that it must be ahead by the angle required to move the valve a distance equal to the outside lap. This angle, represented in the figure by α , is called the **lap angle**.

79. Lead. In real engines it is further desirable to start the admission of steam just before the piston arrives at the end of its stroke. This assists in bringing the moving parts to rest, raises the pressure in the clearance to full value before the piston starts, and gives a wider opening through which the steam can flow during the early part of the stroke, thus reducing wiredrawing and loss of area at the top of the diagram. If the valve is to open before the piston reaches the end of its stroke, the crank driving it must be shifted still further ahead of the engine crank. It must be shifted ahead by an angle which will draw the valve through the distance which will give the desired opening of valve with the piston at the end of its stroke as shown by b in Fig. 109. The angle required, indicated

by β , is known as the **angle of lead**, and the width of the steam opening with engine crank on dead center, i.e., the distance b , is known as the **lead**. The lead varies from less than $\frac{1}{16}$ in. on small engines and with low speeds up to over $\frac{1}{8}$ in. on large engines and with very high speeds.

80. Angle of Advance. The eccentric or valve-operating crank must be ahead of the engine crank by an angle equal to $90^\circ + \text{angle of lap } \alpha + \text{angle of lead } \beta$, as can be seen

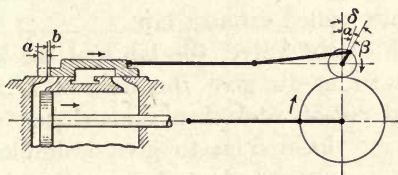

FIG. 109.—Lead b and Lead Angle β .

by an inspection of Fig. 109. The sum of α and β is called the **angle of advance** and will be represented by δ . This is the number of degrees in excess of 90 by which the eccentric leads the engine crank.

Fig. 109 shows that cut-off in an engine fitted with a valve having lap and lead must occur when the engine crank has turned through an angle equal to $180 - 2\alpha$, because the valve will then have returned to the closed position. Apparently, cut-off can be made to occur at any point in the stroke by properly choosing the value of α , but it will be discovered later that the exhaust events set a limit to increase in the value of this angle and hence do not permit of cut-off occurring earlier than a certain fraction of the stroke.

81. Exhaust Lap. Inspection of Fig. 105 will show that the simple valve without lap originally assumed will give no compression, because the cylinder end is connected to the exhaust cavity for the entire stroke. Inspection of all

the changes which have been suggested in the subsequent paragraphs will show further that if the inner edges of the valve are left in the original positions the exhaust events will be considerably distorted in the case of a valve having steam lap and lead.

This trouble may be remedied by moving the inner edges of the valve closer together, making the exhaust cavity in the valve shorter and giving *inside lap* as shown in Fig. 107 by *b*. When the inner edges of the valve control exhaust, as in the case of the valve under discussion, this inside lap is also called exhaust lap.

The length of the valve, the lap and the lead are generally chosen so as to give the desired arrangement of admission and cut-off and then the exhaust edges are so

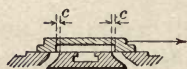

FIG. 110.

located as to give desirable release and compression. In some forms this necessitates the use of an exhaust cavity in the valve such as that shown in Fig. 110.

The amount by which the edges of the valve fail to meet the inner edges of the port is spoken of as **negative inside lap**. This dimension is indicated by *c* in the figure.

It should be noted particularly that all measurements of lap are made with the valve central on its seat and that the measurement of lead is made with the piston at the end of its stroke, i.e., with the engine crank on dead center.

82. The Bilgram Diagram. The action of all slide valves could be studied by means of drawings of the actual mechanism, as has been done in preceding paragraphs, but such a method is time and space consuming. Numerous diagrams such as the Elliptical, the Sweet, the Zeuner and the Bilgram have been developed for the purpose of simplifying and expediting such studies and, when properly understood, they are very convenient. The scope of this book does not permit a discussion of all of these diagrams

and, since the Bilgram diagram is probably the most generally applicable, attention will be confined to it.

The construction of this diagram is illustrated in Fig. 111. The point O represents the center of the engine crank shaft and the two circles drawn about this point as a center represent respectively the paths traveled by the

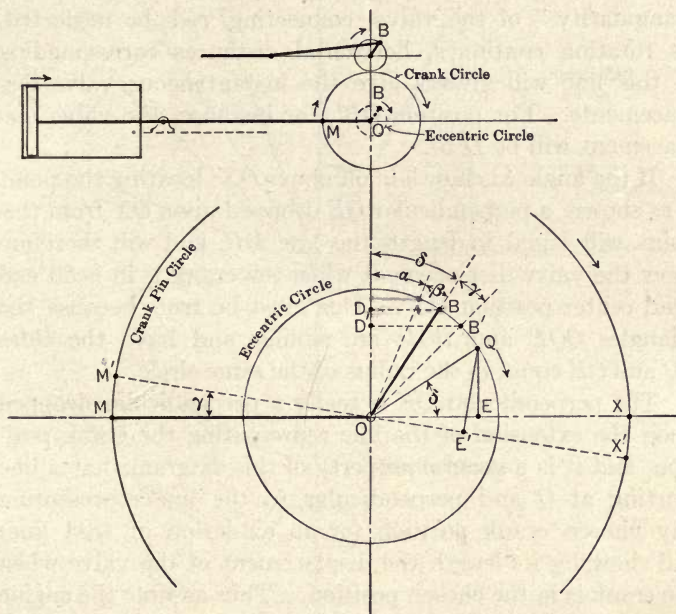

FIG. 111.

pin of the valve crank and the pin of the engine crank. These circles are drawn to any convenient scales.

The diagram is conventionally drawn in such a way that the line OM represents the head end dead center position of the crank and in all subsequent paragraphs the relative positions shown by the small sketch in Fig. 111 will be assumed. The cylinder will be assumed to the

left of the shaft and the engine will be assumed to run "over."

With the crank in position OM , the eccentric (equivalent crank) must be in the position OB , ahead of the crank by an angle $90^\circ + \alpha + \beta = 90 + \delta$. The valve must then be displaced to the right of its central position by an amount represented by the distance DB , if a small correction for "angularity" of the valve connecting rod be neglected. As rotation continues, horizontal distances corresponding to this line will always give the instantaneous valve displacements. For position OB' , for instance, the valve displacement will be $D'B'$.

If the angle δ is now laid off above OX , locating the point Q as shown, a perpendicular QE dropped upon OX from this point will equal in length the line DB , and will therefore show the valve displacement when the crank is in head end dead center position OM . This must be true, because the triangles QOE and BOD are similar and have the sides OQ and OB equal to the radius of the same circle.

The perpendicular QE is really a perpendicular dropped upon the extension of the line representing the crank position, and it is a general property of this diagram that a line starting at Q and perpendicular to the line representing any chosen crank position (or an extension of that line) will show by its length the displacement of the valve when the crank is in the chosen position. Thus assume the engine crank to rotate through the angle γ to the position OM' . The eccentric will have rotated to B' and the valve displacement will be represented by $D'B'$. A perpendicular drawn from Q upon OX' , the extension of the crank position, gives QE' equal to $B'D'$ and hence representing the valve displacement to the same scale.

This construction drawn for different crank positions OA , OM , OM_1 , OM_2 , etc., is shown in Fig. 112, the dash-dot radial lines about Q representing the various values of the valve displacement. The number of each of these

ing the lead EF , the remainder FQ gives the lap of the valve. A circle drawn about Q with radius equal to QF (or a circle drawn about Q and tangent to the line L) will cut off of the lines representing valve displacement the amount representing the part of each displacement used in over-running the lap of the valve. The remainders, that is the parts of the lines radiating from Q in Fig. 112 which are outside of the lap circle, must then represent the amounts by which the valve port is actually open.

It will be observed that the valve is open by the amount of the lead when the crank is on dead center, position OM . The crank position for which the valve displacement is just equal to the lap, and hence at which the valve is just beginning to open, can be found by drawing a tangent through O to the lower side of the lap circle and then extending it to give the crank position OA in Fig. 112.

As the crank rotates clockwise from this position, the valve opens wider until, when position OM_3 is reached, the greatest valve opening exists. Further rotation results in partial closure of the valve and, when the crank has finally rotated into position OC , the valve has just closed, that is, cut-off has occurred, the displacement being just equal to QG , the steam lap.

Thus this diagram, as so far developed, indicates crank positions for admission and cut-off and the values of valve displacement and valve openings for all intermediate crank positions.

ILLUSTRATIVE PROBLEM

A certain valve has an external steam lap equal to $1\frac{1}{4}$ ins. The lead is $\frac{1}{16}$ in. and the throw of the eccentric is $2\frac{1}{2}$ ins. (a) Construct such parts of the Bilgram diagram as are necessary to indicate "head end" crank positions for admission, maximum valve opening and cut-off. (b) Indicate on this diagram the amount of valve opening at various crank positions between admission and cut-off. (c) Determine the value of the angle of advance.

Draw a circle with radius equal to the eccentric throw, $2\frac{1}{2}$ ins., using any convenient scale. This circle is designated by $abcd$ in Fig. 113. Draw about the same center another circle of any convenient size. Draw in the horizontal diameter ac and extend as shown. On the right-hand side of the circle draw the line ef ,

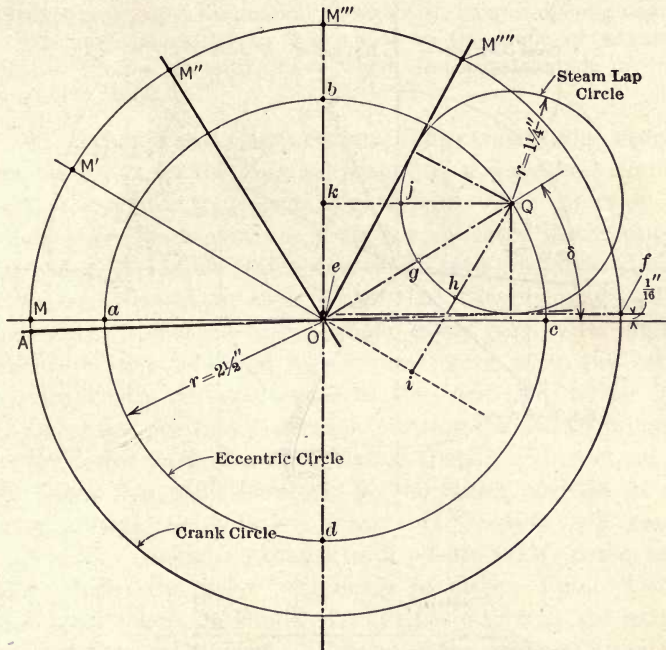

FIG. 113.

parallel to the horizontal axis and a distance above it equal to the lead, $\frac{1}{16}$ in., to the same scale as that chosen for eccentric circle. The steam lap circle must have its center Q on the upper right-hand quadrant of the eccentric circle, and it must be tangent to the line ef . Its radius must equal the steam lap, $1\frac{1}{4}$ in. to scale. Therefore, with compass points set the proper distance apart, find the center Q , about which a $1\frac{1}{4}$ -in. radius circle will just be tangent to the line ef , and draw the steam lap circle.

The crank position at admission is found by drawing the line AO so that, if extended, it is tangent to the lower side of the steam lap circle.

The crank position at cut-off is found by drawing the line

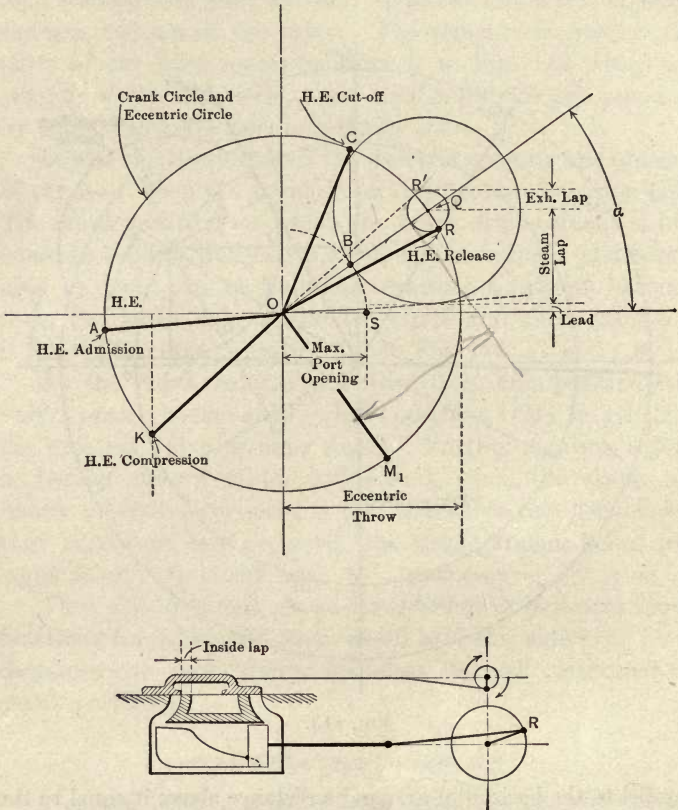

FIG. 114.

$M''O$ in such position that it is tangent to the upper part of the steam lap circle.

The crank position for maximum valve opening is found by drawing the line $M''O$ in such position that a line through QO will be perpendicular to it. The amount of valve opening at this

crank position is shown by the length of the part of this perpendicular line outside of the steam lap circle. i.e., the distance Og interpreted according to the scale chosen for eccentric and steam lap circles.

When the crank is in position $M'O$, the length of hi , interpreted to scale, gives the amount by which the valve is open to steam.

When the crank is in position $M''O$, the length of jk , interpreted to scale, gives the amount by which the valve is open to steam.

The angle indicated by δ is equal to the angle of advance because of the property upon which the construction of this diagram is based.

83. Exhaust and Compression. The exhaust edge events can be shown on the Bilgram diagram by a method similar to that used for the steam edge events. The direction in which valve displacements occur are indicated in the upper part of Fig. 114 in which the crank and eccentric circles have been drawn to such scales that they coincide. Inspection of the small sketch in the lower part of the figure will show that head end release must occur when the valve has traveled a distance equal to the inside lap to the left of its central position. A crank position OR drawn tangent to the lower part of a circle about Q with radius equal to the inside lap will, therefore, be the crank position at release. Clockwise rotation from this position will result in a wider opening to exhaust until position OM_1 is reached, after which the valve will begin to close. Final closure will occur when the crank reaches position OK , the extension of which is tangent to the top of the exhaust lap circle. At that time the valve will have returned (moving from left to right) and will still have to move a distance equal to the exhaust lap before attaining a central position.

ILLUSTRATIVE PROBLEM

Given the exhaust lap of a D-slide valve equal to $\frac{3}{8}$ in.; the steam lap $1\frac{1}{4}$ ins.; the throw of the eccentric, 2 ins.; and the lead $\frac{1}{8}$ in. Find the angle of advance, the maximum port opening to steam and to exhaust, and the crank positions of cut-off, release, compression and admission for the head-end of the cylinder.

Draw the eccentric (and crank) circle with a radius equal to 2 ins., and draw the horizontal diameter as in Fig. 115.

Draw a horizontal line in the upper right-hand quadrant at a distance of $\frac{1}{8} + 1\frac{1}{4}$ ins. above the horizontal diameter. Locate the point Q at intersection.

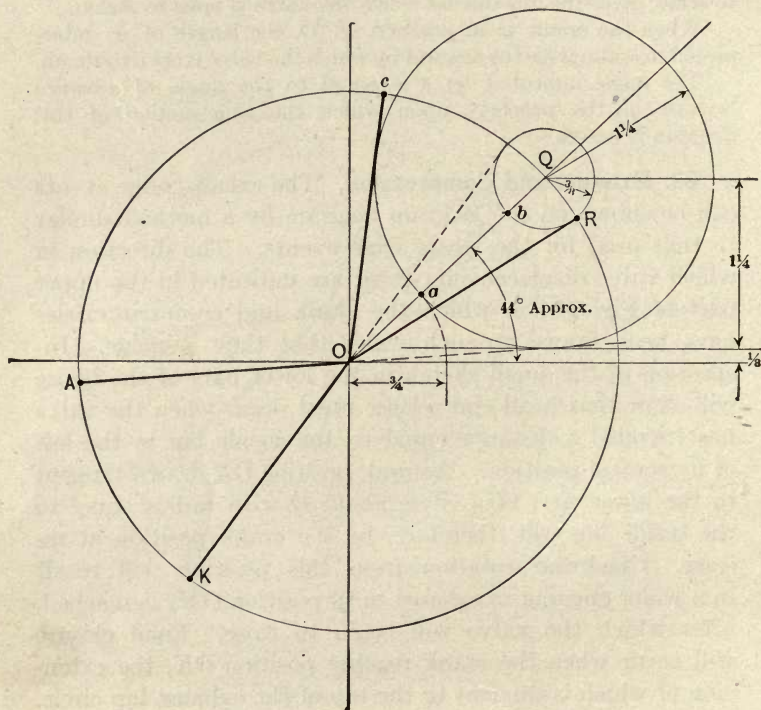

FIG. 115.

Draw the steam lap circle with a radius $1\frac{1}{4}$ in. and the exhaust lap circle with a radius $\frac{3}{8}$ in.

The angle of advance is the angle between OQ and the horizontal.

The maximum opening to steam is given by the distance $Oa = \frac{3}{4}$ in. The maximum opening to exhaust is given by the distance $Ob = 1\frac{5}{8}$ in.

The crank positions shown are obtained by drawing lines

tangent to the lap circles. *A* represents admission; *C*, cut-off; *R*, release, and *K*, beginning of compression.

The piston positions at the times of these events are given to reduced scale by vertical projection.

84. Diagram for Both Cylinder Ends. The complete diagram for the head end cylinder is shown in Fig. 114 with all critical crank positions marked. The positions for the crank end of the cylinder can be found in a similar way by constructing a diagram in which the point *Q* and the lap circles are located in the opposite quadrant. The resulting

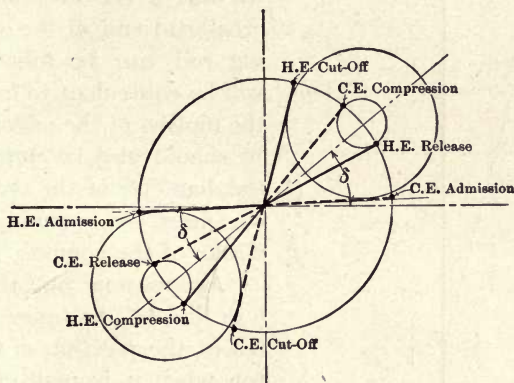

FIG. 116.

diagram for both cylinder ends, with laps the same for both ends of the valve, is given in Fig. 116.

85. Piston Positions. The valve events might be studied entirely in conjunction with crank-pin positions, but it is more convenient and customary to consider them in connection with piston positions. Piston positions corresponding to different crank-pin positions could be found by drawing the mechanism to scale for each different position as shown in Fig. 117 for piston positions 1 and 2.

It is obvious that this would involve a great deal of work and that, if drawn to large scale, it would consume a great

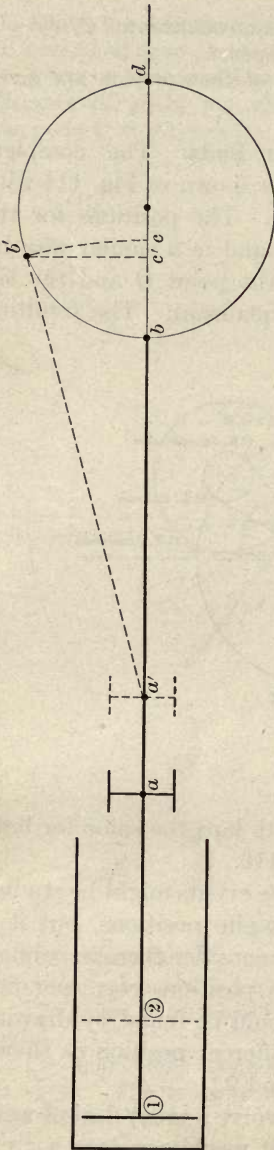

FIG. 117.

deal of space. Further, it is convenient to be able to locate relative piston positions on the line which serves as the horizontal diameter of the crank circle of the Bilgram diagram.

The method used depends upon the fact that the motion of the crosshead is exactly the same as that of the piston, so that if the motion of the crosshead end of the connecting rod can be followed, it will be equivalent to following the motion of the piston itself. It should also be noted that the diameter of the crank circle must be equal to the stroke of the engine.

Assume now, that the point *b* in Fig. 117 be taken to represent the position of the piston when it is really in position 1. When the piston has moved to position 2, the crosshead will have moved from *a* to *a'* and the crank pin from *b* to *b'*. If with *a'* as a center the connecting rod be swung down to the horizontal its right-hand end will arrive at the point *c*. The distance *bc* must then represent the distance that crosshead (and piston) have moved from dead-center position because *ab* and

$a'c$ both represent the length of the connecting rod and c must therefore be as far to the right of b as a' is to the right of a . The point c may therefore be taken to represent piston position when the connecting rod is in the position $a'b'$.

In general, if the horizontal diameter of the crank shaft be taken to represent the stroke of the engine, the piston position corresponding to any crank position can be found by taking a radius equal to the connecting-rod length (to the same scale as the circle) and striking an arc from the

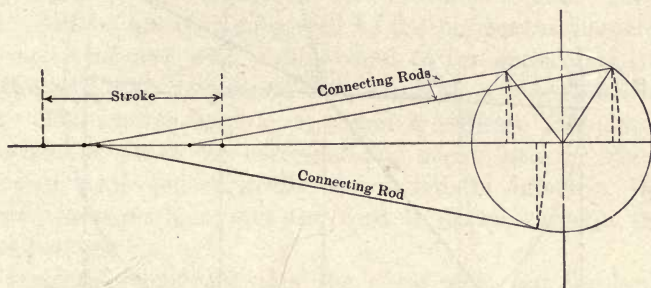

FIG. 118.

crank-pin position, using a center on the horizontal line on the cylinder side of the crank circle.

An approximate method is also used for finding the piston position. Instead of projecting down from the crank-pin position with an arc, such as $b'c$ in Fig. 117, a vertical line through the crank-pin position is used. Such a line would give c' as the piston position when c is really correct. This method would give accurate results with a connecting rod of infinite length. For ordinary lengths of rod, however, the results are far from correct. The error is said to be due to the **angularity of the connecting rod**.

The effect of the angularity of the connecting rod is shown in Fig. 118 for different positions. On the outstroke the piston is always farther ahead than the rectilinear pro-

jection would indicate. On the return stroke the piston is always behind the position indicated by rectilinear projection.

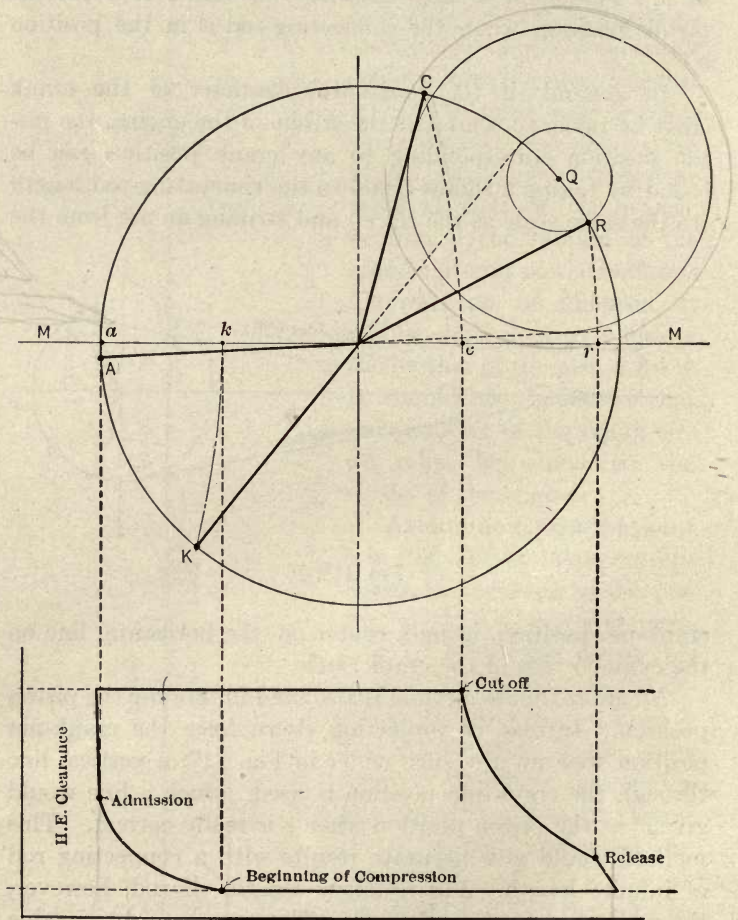

FIG. 119.

86. Indicator Diagram from Bilgram Diagram. Since the piston positions corresponding to different crank posi-

tions can be determined, it is a comparatively simple matter to construct the indicator diagram which theoretically would be given by an engine fitted with a valve of certain dimensions. It is necessary to assume the upper and lower pressure and also to assume the form of the expansion and compression curves. These are generally taken as rectangular hyperbolas.

The method of constructing an indicator diagram from the Bilgram diagram is shown in Fig. 119. The crank-pin positions for admission (*A*), cut-off (*C*), release (*R*) and beginning of compression (*K*) are first found. These pin positions are then projected to the horizontal diameter by means of arcs with radius equal to the connecting-rod length and with centers on the line *MM* produced to the left. The intersections *a*, *c*, *r* and *k* indicate the piston positions at which the corresponding events occur. These are then projected vertically downward to intersect the proper pressure lines and the card is drawn through the intersections.

Diagrams constructed in the same way, but for both head and crank ends, are given in Fig. 120. A symmetrical valve was assumed, that is, one built exactly alike on head and crank ends. The diagrams show that such a valve cannot give the same results for both cylinder ends because of the effect of the angularity of the connecting rod. It is most evident in the case of cut-off. The cut-off in this case occurs just before three-quarter stroke for the head end and just after half stroke for the crank end of the cylinder. All other events are distorted in the same way, but the actual lengths of the variations are not as great as in the case of the cut-offs and therefore the distortion is not as obvious.

The effect of the angularity of the connecting rod upon the diagrams can be remembered easily if it is noted that all valve events occur later with respect to piston position on the outstroke and earlier on the instroke than they would with a connecting rod of infinite length.

It is possible to "equalize" the cut-offs, that is, make them occur at the same fraction of the stroke by using unequal steam laps at opposite ends of the valve, but this will result in still further distortion of admissions, as can be seen by constructing a Bilgram diagram for this case. Similarly, the compressions can be equalized by the use of

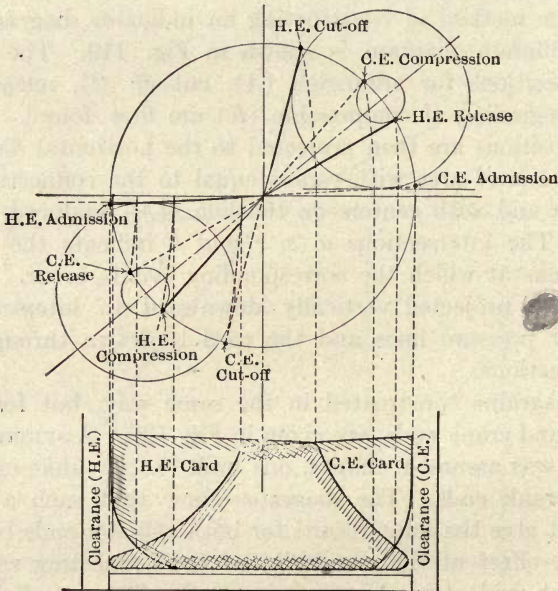

FIG. 120.

unequal exhaust laps, but this results in distortion of the release events.

Various linkages have been developed which are so arranged that they distort the motion of the valve to just the extent necessary to counterbalance the effects of the angularity of the connecting rod. The scope of this book does not, however, permit a discussion of such valve gears.

87. Limitations of the D-slide Valve. The simple valve discussed in the preceding paragraphs has numerous limitations and is therefore only used on small and cheap engines, or in cases where economy in the use of steam is not essential. This valve, when used with steam entering over the outside edges as previously considered, is pressed to its seat by the live steam acting over its entire upper surface. This pressure is practically unbalanced, as the greater part of the lower surface of the valve is subjected to the low pressure of the steam being exhausted. As a result the friction to be overcome in moving the valve is very great and there is an appreciable loss from this source.

Further, the shape of the valve makes necessary the use of long ports which form part of the cylinder clearance and which are alternately exposed to live and to exhaust steam with results previously discussed. These ports can be decreased in length by increasing the length of the valve, but this in turn increases the area exposed to high pressure and hence increases the friction loss.

It can be shown by means of the Bilgram diagram that, if a cut-off earlier than about $\frac{5}{8}$ stroke is desired, the angle of advance, the amount of steam lap and the size of the eccentric must all be made very great. This results not only in large friction losses, but also in very early release and compression, because of the great angle of advance. As a result, slide valves of the simple D type are seldom used when a cut-off earlier than $\frac{1}{2}$ to $\frac{5}{8}$ stroke is desired. It should be remembered in this connection that the simple engine generally gives its best economy with a cut-off of about $\frac{1}{4}$ stroke.

The drawing of lines representing the opening of the valve to steam as in Fig. 112 will show that this simple valve is further handicapped by the very slow opening and closing of the steam ports, causing a great amount of wire drawing with a corresponding loss of diagram area. In order to get an adequate opening to steam the valve

must also be given a great displacement and, since this occurs under great pressure, it results in great friction loss.

The unbalanced feature can practically be overcome by rolling up the valve and ports about an axis parallel to the length of the cylinder. This gives what is known as a **piston valve**, shown diagrammatically in Fig. 121

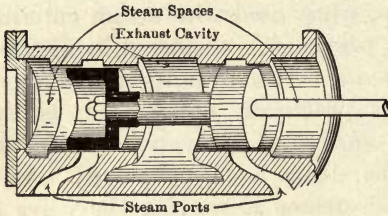

FIG. 121.—Piston Valve.

It can also be partially overcome by using a balance plate or ring of some kind between the top of the valve and the inside of the steam-chest cover, so arranged that live steam is excluded from the greater part of the upper surface of the valve. Valves of this type are generally called **balanced slide valves** and are used on many high- and medium-speed engines.

The valve travel required for obtaining a given opening

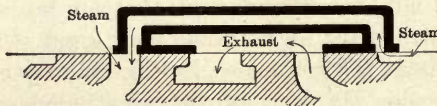

FIG. 122.—Allen Double Ported Valve.

can be decreased and the rate of opening and closing can be increased by the use of multiported constructions. These are so arranged that two or more ports open or close at the same time, so that the total movement required for a given opening is divided by the number of ports and the rate of opening and closing is multiplied in the same proportion. One simple type of double-ported valve is illustrated in Fig. 122.

When several ports are used the valve often becomes

a rectangular frame crossed by a number of bars and is known as a **gridiron valve**, because of its appearance. Such valves are often combined with balance plates and give very satisfactory results.

A number of designs of slide valves have been developed for the purpose of making cut-off independent of the other events. Many of these use a separate cut-off valve which either controls the steam supply to the main valve or else rides on the main valve and controls cut-off by covering ports in that valve. Devices of the latter type are called **riding cut-off valves**. They are either driven by separate eccentrics, or by linkage from the eccentric controlling the main valve, the linkage being so arranged as to give the proper relative motion between main and auxiliary valves. In such designs the main valve is proportioned so as to give the desired admission, release and compression and the cut-off is then taken care of by proper adjustment of the cut-off valve.

88. Reversing Engines. It was shown in one of the early paragraphs of this chapter that the eccentric must be set $90^\circ + \text{angle of advance}$ ahead of the crank, ahead meaning in the direction of rotation. To cause the engine to revolve in the opposite direction, that is, to "reverse" the engine, it is therefore only necessary to shift the relative positions of eccentric and crank so that the eccentric leads the crank by $90^\circ + \delta$ in the new direction of rotation. This corresponds to shifting ahead (in first direction of rotation) through an angle equal to $180 - 2\delta$ or shifting backward through an angle equal to $180 + 2\delta$, as can be seen by inspection of Fig. 109.

In practice it is generally more convenient to use two eccentrics, one set properly for rotation in one direction and the other set properly for rotation in the opposite direction. This arrangement is shown diagrammatically in Fig. 123. This figure is drawn for a vertical engine and in such position that the engine is on crank-end dead center.

The point *P* represents the position of the center of the crank pin; the point *f* represents the position of the equivalent crank (center of eccentric) which drives the valve for "forward," "ahead" or clockwise rotation; and the point *b* represents the position of the equivalent crank which drives the valve for "backing," "reverse," or counter-clockwise rotation.

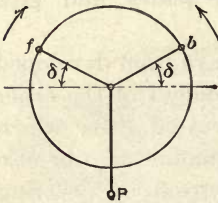

FIG. 123.

The real mechanism, in one of its numerous forms known as the Stephenson Link Gear, is shown in perspective in Fig. 124. The forward eccentric corresponds to *f* of Fig. 123 and the backing eccentric corresponds to *b* of that figure. The eccentric rods are fastened to opposite ends of a curved "link" and move the valve through a "link block" fastened to the end of the valve stem. In the position shown in the figure the link is in such position that the forward eccentric operates practically directly on the valve stem so that the valve motion is practically entirely governed by that eccentric.

If the reverse shaft were to be rotated clockwise into the backing position, the "suspension rods" would pull the link over until the eccentric rod of the backing eccentric was directly under the valve stem. Under such conditions the valve motion would be controlled almost entirely by the backing

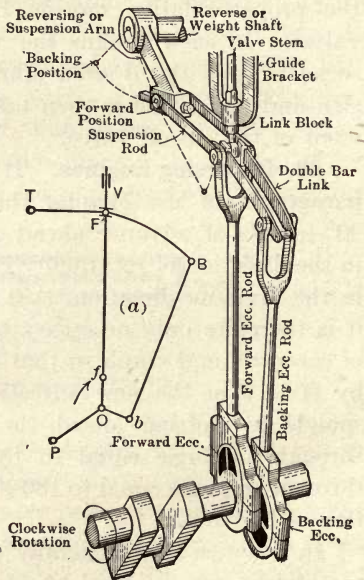

FIG. 124.—Stephenson Link Gear.

eccentric and the engine shaft would rotate counter-clockwise.

If the mechanism were so set that the link block occupied a position on the link between the ends of the two eccentric rods, the valve motion would be controlled by both eccentrics and would be a compromise between the motions given by either eccentric separately. It is characteristic of this gear that the cut-off is latest when either one or the other eccentric is fully "in gear" and that it becomes earlier as the link block approaches the center of the link. With the link block in the center of the link the valve does not open at all, i.e., the cut-off occurs at zero stroke.

There are numerous other forms of link gears, the best known being the Gooch, the Allan and the Porter-Allen. There are also numerous reversing mechanisms known as radial gears in which the motion of the valve is controlled by means of a "radius rod" which can be set to give the desired valve motion. The valve motion is obtained indirectly through the radius rod from an eccentric, from the crank, or from the connecting rod. The limits of this book do not permit a detailed discussion of these forms.

89. Valve Setting. From what has preceded it will be evident that it is not only necessary that a valve and its seat and driving mechanism be correctly designed, but also that the various parts must be correctly connected up in order that the valve may move in its proper phase relation with respect to the piston.

Adjusting the mechanism in such a way that the proper phase relations are obtained is known as **setting the valve**. This can be done with fair accuracy by a simple study of the mechanism in various positions, as will be shown below, but it is always advisable to check the setting by means of indicator diagrams taken after the setting is completed. Such diagrams will often show errors of such character or size that they cannot be determined by measurement on an engine which is not operating.

Before beginning operations it is always advisable to go over the entire engine carefully and to eliminate excessive lost motion at all pins and bearings in order that the relative positions of parts obtained while setting the valve may approximate those which will be obtained when the engine is in operation. The effect of lost motion will be appreciated after a study of Fig. 125. Assume that all parts of the mechanism are tight except the crank-pin end of the connecting rod as shown. If the engine is rotated by hand,

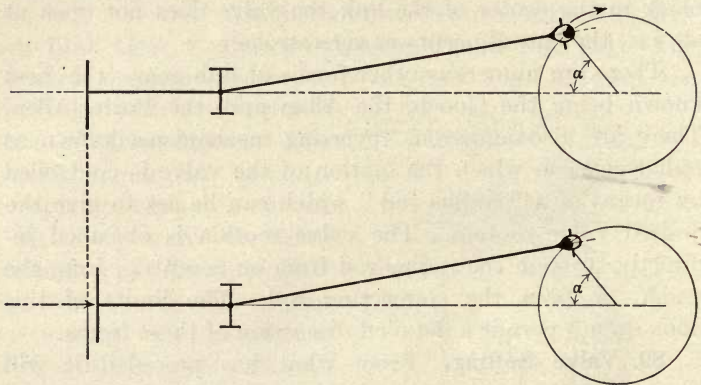

FIG. 125.

for instance, by turning the fly-wheel, the crank will pull the piston mechanism and the piston will be drawn into the position shown in the upper half of the figure when the crank has turned through an angle α . On the other hand, when the engine is operating under steam, the piston will push the crank pin around and will occupy a position such as that shown in the lower half of the figure when the crank has been turned through the same angle α . Obviously, the piston can occupy two very different positions for the same crank position, and a valve setting based upon the conditions shown in the upper part of the figure might be

very incorrect when used under the conditions shown in the lower part of the figure.

Lost motion in any part of the mechanism can produce analogous results and it is therefore necessary to remove as much of it as possible before attempting to set the valve. It is practically impossible to eliminate all lost motion, as there must be sufficient clearance at all bearing surfaces to accommodate a film of oil, and this alone would make necessary the taking of indicator diagrams for the checking of valve settings, even if it were possible to set perfectly by measurement for stationary conditions.

In general, there are two adjustments which can be made in setting a plain slide valve. The length of the valve stem or eccentric rod can be changed and the eccentric can be shifted around the shaft. It is necessary to understand the effects of each of these adjustments.

Changing the length of the valve stem is equivalent to shifting the valve upon its seat without moving the engine as shown in Fig. 126. In this figure the valve is shown in its central position by full lines. The lap is the same at both ends. If, now, the valve is worked to the right upon its stem by adjustment of the nuts shown, until it reaches the dotted position, the head-end lap will have been decreased and the crank-end lap will have been increased by the same amount. This would make admission earlier and cut-off later for the head end and admission later and cut-off earlier for the crank end. Obviously, the effects of changing the length of the valve stem are opposite for the two ends of the cylinder.

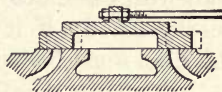

FIG. 126.

Shifting the eccentric about the shaft simply changes the time relation between valve motion and piston motion; it does not alter the valve motion itself. If difficulty is experienced in realizing the truth of this statement, it is only necessary to draw several Bilgram diagrams for the

same valve, but with different angles of advance, and then to construct indicator diagrams for both cylinder ends in every case. It will be discovered that shifting the eccentric ahead in the direction of rotation, for instance, will make all events occur earlier with respect to piston position for both ends of the cylinder.

In setting a plain slide valve which is built symmetrical about a central axis, i.e., same inside and outside lap at each end, it is first necessary to adjust the length of the valve stem. This may be done by removing the steam-chest cover so as to expose the valve and then rotating the engine slowly by hand and observing the distance traveled by the valve on each side of its central position. This is conveniently done by observing the distance between the outer edge of the steam port and the outer edge of the valve when the valve is fully open at each end. If the valve travels further toward the head end than it does toward the crank end, with reference to the port edges, the valve stem must be shortened; if it travels further toward the crank end the stem must be lengthened.

In making these adjustments it is advisable to turn the engine only in the direction in which it is going to rotate, so that any lost motion in the valve mechanism will have approximately the same effect as when the engine is operating.

When the length of the valve stem is correctly adjusted, the eccentric must be so set on the shaft as to give the proper angle of advance. This is commonly done by shifting it about the shaft until the proper value for the steam lead has been obtained. In order to determine the value of the lead it is necessary to be able to set the engine on each dead center. This can be done approximately by turning the engine until the crosshead has come to either end of its stroke, but it will be found by trial that the fly-wheel and shaft can be turned through a very large angle at each end of the stroke without causing an appreciable motion of the crosshead,

so that this method is not very satisfactory for the purpose of adjusting the eccentric. It is customary, therefore, to work in such a way as to give a more accurate determination of shaft and crank positions for dead center.

The engine is rotated until the crosshead has been brought near one end of its stroke, as shown in Fig. 127, and a mark is then scribed across the crosshead and guide as at ab . An arc xy is then marked on the fly-wheel by means of a tram such as that shown, the end c being placed

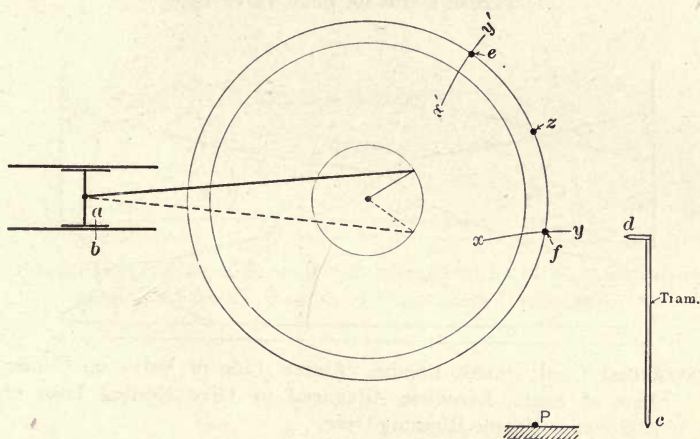
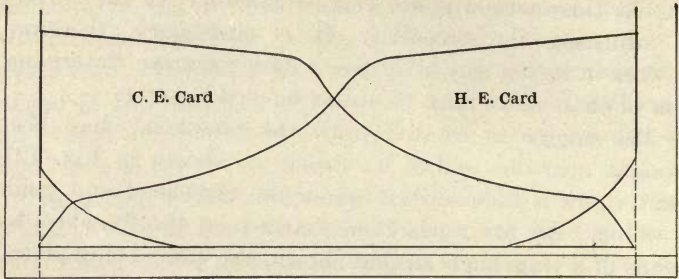
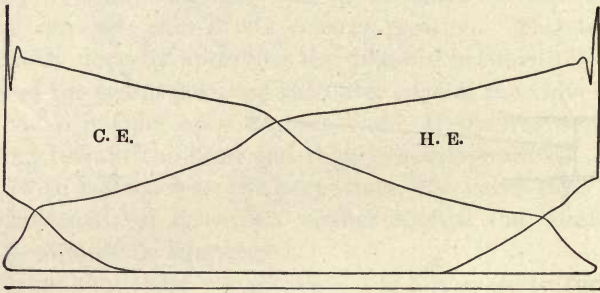

FIG. 127.

at point P on some solid part of foundation or floor. The engine is then rotated, clockwise in the figure, until the crosshead has reached the end of its stroke and returned to such a point that the marks on crosshead and guides again coincide, as shown by dotted positions in the figure. The arc $x'y'$ is then scribed on the fly-wheel with the tram, the end c again bearing on the point P . A point z is then found by bisecting the arc ef and when this point is brought under point d of the tram the crank will obviously be at crank-end dead center and the piston at the crank end



(a) Perfect Cards for Slide Valve Type.



(b) Actual Card; Small Engine. Center Line of Valve on Center Line of Seat; Eccentric Advanced to Give Normal Lead of 0.05 inch. Engine Running Over.

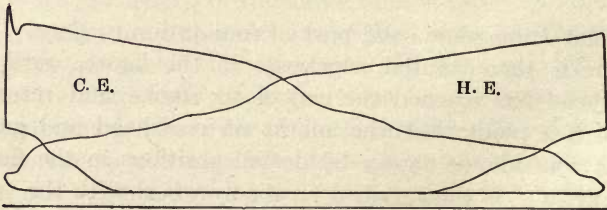

(c) Same Setting as (b) except Engine Running Under.

FIG. 128.

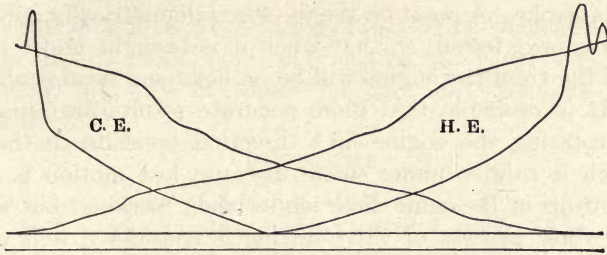

(d) Angular Advance of Eccentric Increased. Valve Stem Length Same as in (b) and (c). Lead 0.375 Inch.

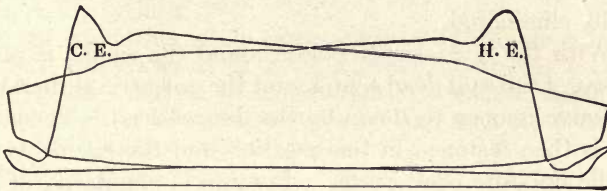

(e) Angular Advance of Eccentric Decreased so as to Give Negative Lead of 0.5 Inch. Length of Valve Stem Unchanged.

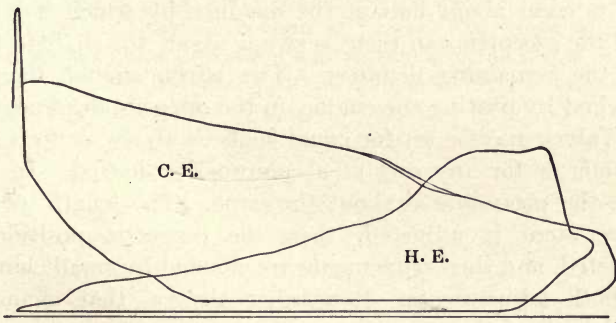

(f) Length of Valve Stem Changed; Angle of Advance as in (b).

FIG. 128.

of its stroke. A point on the fly-wheel diametrically opposite to z is next found, so that when it is brought under point d of the tram the engine will be on head-end dead center.

It is probable that more accurate results are obtained by rotating the engine in a direction opposite to that in which it rotates under steam, because lost motion is then taken up in the same direction as when working, but when the whole process of valve-setting is considered it is questionable whether this is the correct direction of rotation. Opinion and practice differ in this respect. In the end, the setting should be checked by the taking of indicator diagrams, so that effects of incorrectible lost motion may be finally eliminated.

With the dead-center points found the engine is placed on, say, head-end dead center, and the eccentric shifted until the valve is open to steam by the desired lead. The eccentric is then fastened in this position and the engine turned to the opposite dead center. Because of angularity of connections and of irregularities in valve and seat dimensions, it generally will be discovered that the valve is not now open to steam by the same amount as at the other end. If it is desired that it should be, the valve can be shifted on its stem about half of the distance by which it is out and the eccentric can then be swung about the shaft to take up the remaining distance. The effect should then be checked by putting the engine on the opposite dead center.

Valves may be set for equal leads as above, or for equal cut-offs or for any sort of a compromise desired. In any case the procedure is about the same. The length of the valve stem is adjusted, then the eccentric position is adjusted, and then refinements are effected by small changes of both adjustments. Remember always, that changing the length of the valve stem changes events at opposite cylinder ends in opposite directions, while shifting the eccentric changes all events in the same direction.

The effects of various adjustments are shown by the

indicator diagrams given in Fig. 128. These diagrams were taken from a small, slide-valve engine and serve very well to show the way in which the indicator discloses poor adjustments.

PROBLEMS

1. Given: angle of advance, 30° ; throw of eccentric, $1\frac{1}{2}$ ins.; lead, $\frac{1}{16}$ in.; maximum exhaust-port opening, $1\frac{1}{4}$ in.; find the steam lap, maximum opening to live steam, and the exhaust lap.

2. Given: steam lap of $\frac{7}{8}$ in.; lead of $\frac{1}{16}$ in.; exhaust lap of $\frac{3}{8}$ in.; and the angle of advance equal to 30° . Find the valve travel ($=2 \times$ throw of eccentric) and maximum port opening to steam and to exhaust.

3. An engine has an eccentric throw of $1\frac{3}{4}$ ins.; a steam lap of $\frac{3}{4}$ in.; and a lead of $\frac{1}{16}$ in. Compression begins at $\frac{7}{8}$ of the return stroke. Assume a connecting rod of infinite length and find the angle of advance, the exhaust lap, and the maximum port openings to steam and to exhaust.

4. Given: valve travel, 3 ins.; steam lap, $\frac{5}{8}$ in.; exhaust lap, $\frac{1}{4}$ in.; and lead, $\frac{1}{8}$ in.; find maximum port opening, angle of advance, and piston positions at cut-off, release, compression, and admission for both ends of cylinder, with the length of the connecting rod equal to $4\frac{1}{2}$ times the length of the crank.

5. It is required to build an engine having a steam-port opening of $\frac{3}{4}$ in., a lead of $\frac{1}{16}$ in., and a connecting rod four times the length of the crank. Cut-off must occur at $\frac{3}{4}$ stroke and release at 95% of the stroke. Find the inside and outside lap, the throw of the eccentric and the fraction of stroke completed by the beginning of compression.

CHAPTER XI

CORLISS AND OTHER HIGH-EFFICIENCY ENGINES

90. The Trip-cut-off Corliss Engine. The slide valve has certain limitations which can be partly, but never wholly, overcome. In most slide-valve gears, for instance, the various events occur more slowly than is desirable,

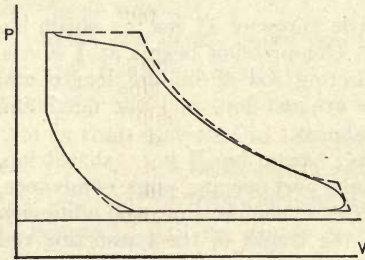

FIG. 129.

and this is particularly true of cut-off. Ideal valves would open suddenly to full opening when necessary and would close as suddenly at the proper time, and such action would give minimum throttling loss and rounding of corners of the diagram. Engines

fitted with such ideal valves would therefore give indicator diagrams with maximum work area as shown by the dotted lines in Fig. 129, the full lines indicating the type of diagram obtained with the ordinary slide valve.

Again, the simpler forms of slide valve involve the use of long ports connecting with the clearance space within the cylinder, thus adding greatly to the clearance surface exposed and to the cylinder condensation. These ports serve for both admission and exhaust, and their walls are therefore periodically cooled by the exhaust steam with the result that excessive condensation occurs during admission.

Many attempts have been made to devise valve gears which should not be subject to the limitations of the

simple slide valve. Some of these have resulted in the development of the more complicated slide valves described in the last chapter, but such designs generally leave much to be desired. One of the earliest and most successful solutions was made by Corliss, who developed what is known as the trip-cut-off Corliss gear.

The long combined steam and exhaust ports are eliminated by the use of four valves, two for steam and two for exhaust. These are rocking valves and are located top and bottom, at the extreme ends of the cylinder, with their longitudinal axes perpendicular to those of the cylinder, as shown in Figs. 50, 51 and 52. The exhaust valves are located below so as to drain out water of condensation. Details of valves of this type are shown in Fig. 130.

These valves may each be regarded as an elementary slide valve which has a cylindrical instead of a flat face, and which is oscillated about a center near the face instead of being reciprocated, i.e., oscillated about a center at an infinite distance.

The valves are operated as shown in Fig. 131 by short links from a wrist-plate pivoted on the side of the cylinder and rocked back and forth about its center by means of an eccentric operating through the linkage indicated. The locations of the various pins and the lengths of the various links are so chosen that the valves travel at high velocity when opening and closing, that they open very wide, and that they close only far enough to prevent leakage and then remain practically stationary until about to open again. Throttling losses are thus decreased and wear caused by useless motion after closure is minimized.

The opening of the admission valves in this gear is effected positively by the linkage already explained, but they are closed differently. For opening, the steam link rotates the bell crank *B* in Fig. 132 and thus raises the latch *C*. The hook on the end of one of the arms of this latch engages the steam arm which is fastened on the end

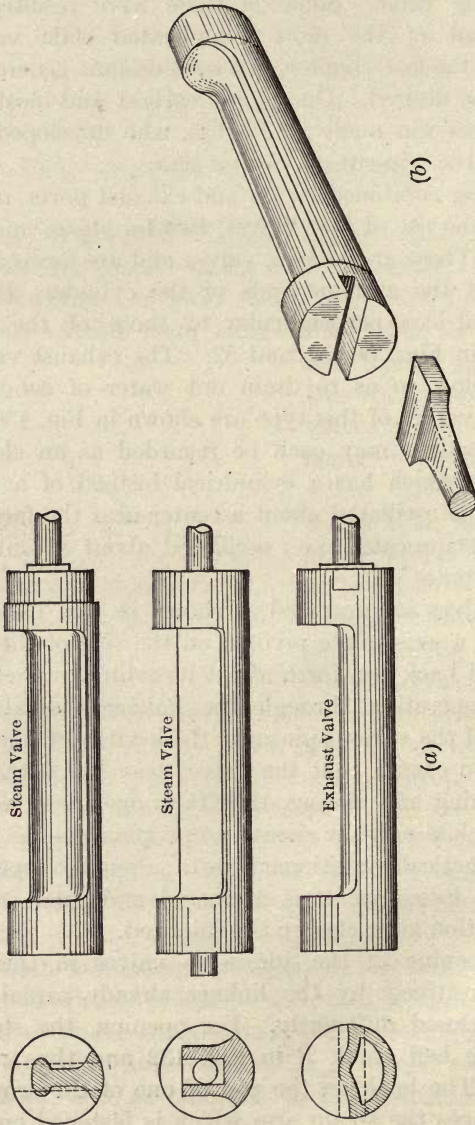

FIG. 130.—Details of Corliss Valves.

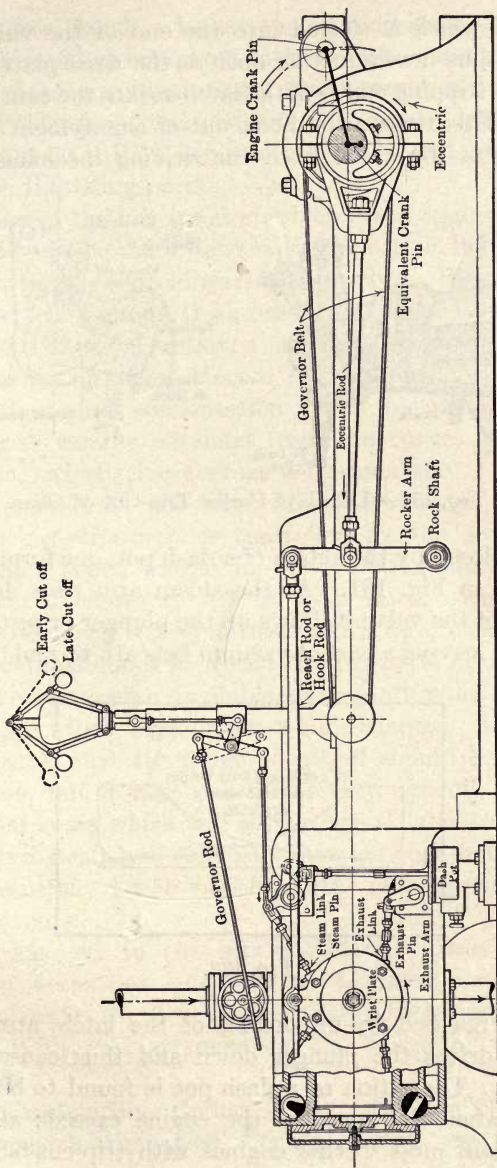

Fig. 131.—Corliss Engine Gear.

of a rod which is slotted into the end of the valve. The valve is thus drawn further open as the wrist plate revolves, until the tripping end *D* of the latch strikes the cam indicated by *E*. This throws the hook out of engagement and thus disconnects the valve from the driving mechanism. The

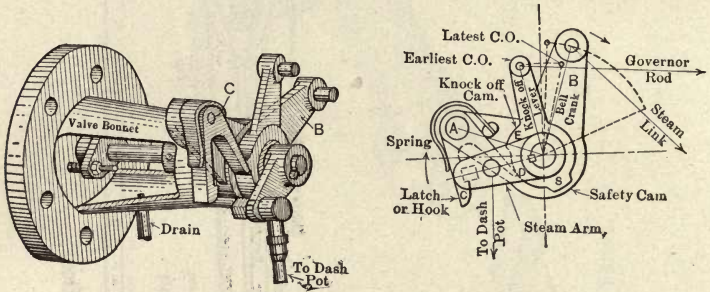

FIG. 132.—Details of Corliss Trip-Cut-off Gear.

valve is closed by the action of a dash pot, one form of which is shown in Fig. 131. As the steam arm rises during the opening of the valve it draws up the plunger or piston of the dash pot, leaving a partial vacuum beneath it, and, when the

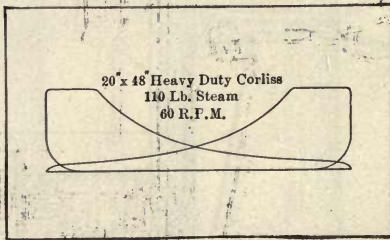

FIG. 133.

valve is released by unhooking of the latch, atmospheric pressure drives the plunger down and thus causes cut-off to occur. The action of a dash pot is found to be unsatisfactory when the speed of the engine exceeds about 125 R.P.M. and most Corliss engines with trip-cut-off operate

at still lower speeds. Under such circumstances the cut-off is very rapid as compared with the piston speed, and the diagram shows a comparatively sharp corner at this point. A set of diagrams obtained from a large Corliss engine operating at 80 R.P.M. is given in Fig. 133, and it is obvious that little throttling occurs.

Because of the low speed at which these engines operate the stroke can be made long with respect to the diameter without attaining a prohibitive piston speed. The economy mentioned in Chapter VII as resulting from the use of long strokes can thus be obtained in these engines. An idea of the saving in steam effected by the partial elimination of throttling and condensation losses by means of the Corliss gear can be obtained from the curves in Fig. 134 (a) and (b), which give average performances.

The position of the cam which determines the time at which cut-off occurs is controlled by the governor of the engine. When moved in the direction taken by the steam arm it causes cut-off to occur later. Variation of the point of cut-off is used in these and in most other engines to control the amount of work done per cycle in order that the engine may make available the quantity demanded at the shaft, as will be explained in a later chapter. It is therefore desirable that the range of cut-off should be as great as possible, but it has been found very difficult to design trip-cut-off gears which will give a cut-off later than about 0.4 stroke if steam and exhaust valves are operated from the same eccentric. Later cut-off causes poor timing of the exhaust events.

This has led to the introduction of Corliss engines with two eccentrics and two wrist plates per cylinder. One set operates the steam valves and the other the exhaust valves. With this arrangement the range of cut-off is unlimited.

91. Non-detaching Corliss Gears. Because of the low speed at which trip-cut-off Corliss engines are operated,

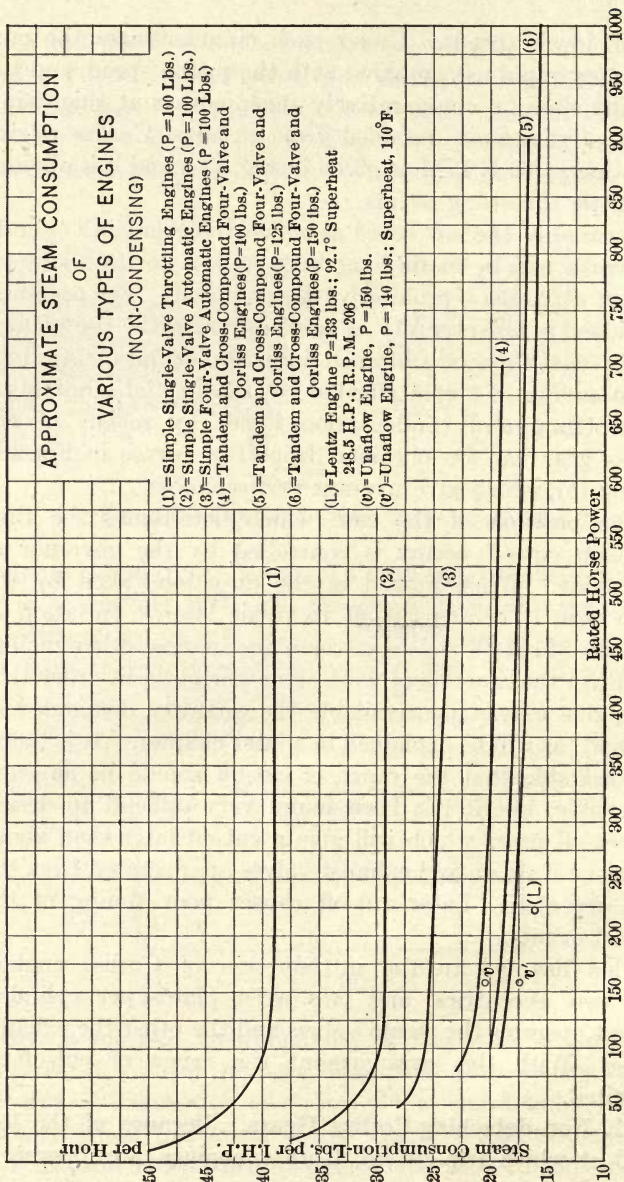

Fig. 134a.—Steam Consumptions of Non-Condensing Engines.

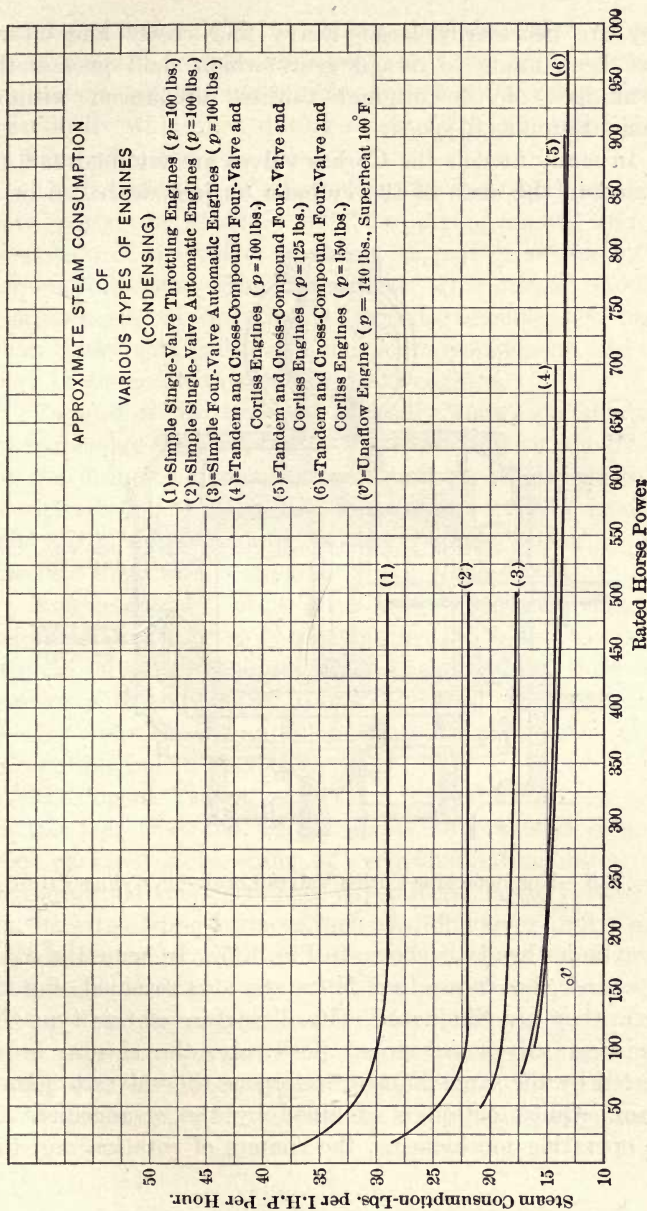

Fig. 134b.—Steam Consumptions of Condensing Engines.

they are necessarily large, heavy and costly and efforts have been made to design gears which shall possess the advantages of the original Corliss mechanism without the limitation as to speed.

In many models the Corliss valves are retained and are located in the ends of the cylinder as just described or in

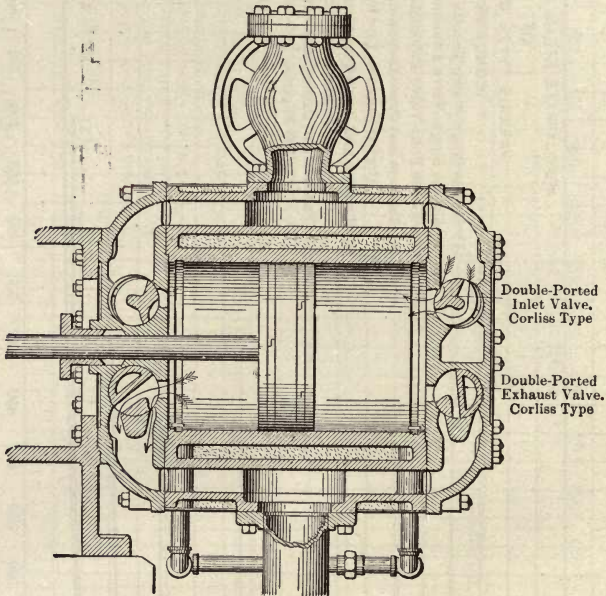

FIG. 135.—Non-detaching Corliss Valves Located in Cylinder Head.

the cylinder heads as shown in Fig. 135. In some the wrist plate and the connecting links are also retained, but in others they are eliminated. In all engines of this type the admission valves are closed positively, the closure being effected by the same linkage that opens the valves to admit steam. Quick action is obtained by the arrangement of the operating mechanisms, the centers of rotation and the

lengths of links being so chosen that the valve travel is small when the valves are closed, that it is rapid when the valves are opening and closing, and that the valves remain practically wide open during most of the time that steam is being admitted.

The advantages of small clearance and short and separate ports are attained in these arrangements and the operation of the valves is almost as perfect as that of the trip-cut-off gear. Engines fitted with these modified Corliss gears are operated at speeds considerably higher than those permissible with the older arrangement, and they may be classed with medium-speed engines.

Engines of this type are generally known commercially as **four-valve engines**, but as this name applies equally well to the ordinary trip-cut-off gear and to others which will be described later, it is best to use some other designation. The term **non-detaching Corliss engines** seems to best describe them and is apparently gaining in favor.

Non-detaching Corliss engines generally give diagrams intermediate between those obtained with the low-speed, trip-cut-off mechanism and those obtained from slide-valve engines with the simpler forms of valves, though the later designs very closely approximate the performances of the trip-cut-off Corliss engine.

92. Poppet Valves. Attention has already been called to the fact that the use of highly superheated steam is very effective in lessening or even eliminating initial condensation. Experience has shown that large valves and valves with sliding surfaces such as slide valves and Corliss valves do not work well with highly superheated steam. The large castings warp so that contact surfaces do not remain true and the lack of moisture which acts as a seal with saturated steam leads to excessive leakage. Difficulty has also been experienced with the lubrication of these sliding types of valves when using highly superheated steam.

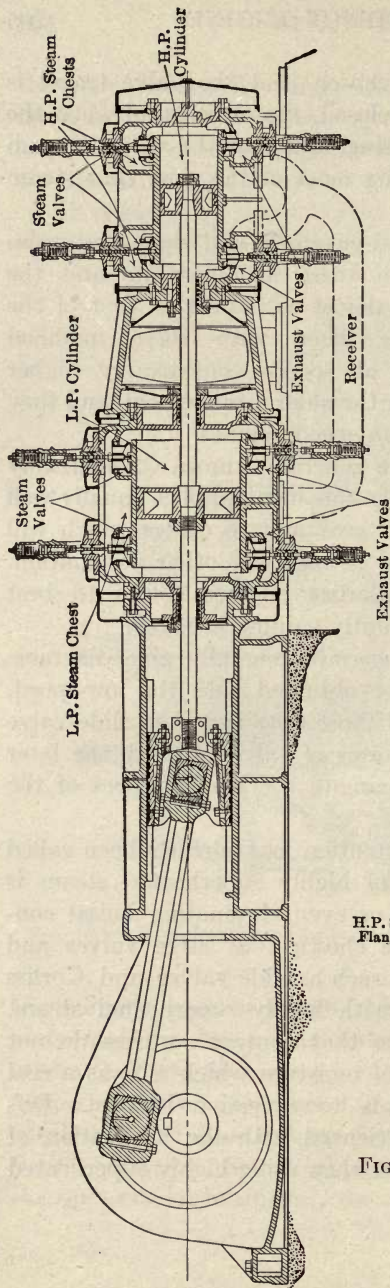

FIG. 136a.—Lentz Poppet Valve Engine.

An old form of valve known as the **poppet valve** has recently been adopted by some builders as a solution of the difficulties met in the use of highly superheated steam. This form of valve in four-valve arrangement, combined with designs in which short ports and symmetrical cylinder castings are used, yields very economical engines which can be safely used with a degree of superheat prohibitively high in the case of the sliding and oscillating forms of valves.

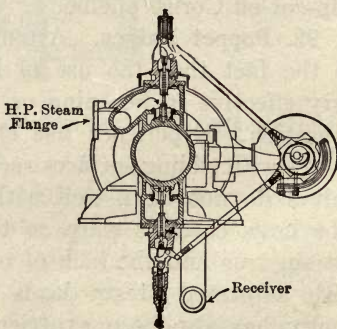

FIG. 136b.—Cross-section, Lentz Engine.

Sections of a modern type of poppet valve engine are shown in Figs. 136 (a) and 136 (b), and details of the admission valve and its operating mechanism are given in Fig. 137 (a) and (b). The valves are all double-seated (double-ported or double-beat), that is, they seat at both ends and are made hollow so that the steam passes both around the outside of the valve and through the valve as shown by the arrows in Fig. 137 (b). This results in large area for passage of steam and in quick opening and

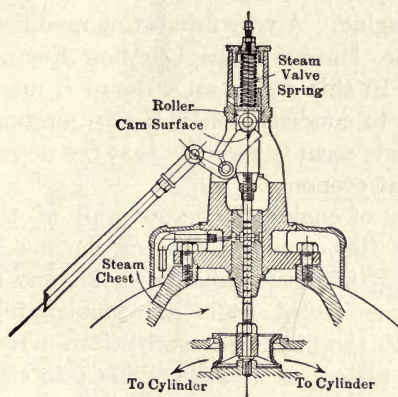

FIG. 137a.—Admission Valve and Operating Mechanism, Lentz Engine.

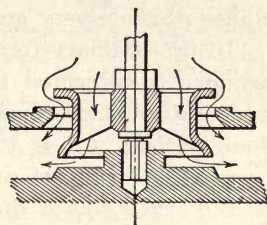

FIG. 137b.

closing, as in the case of gridiron valves, with small actual movement of the valve.

The valves are opened positively by eccentrics operating through cams and rollers as shown in Fig. 136 (b) and they are closed by springs as rapidly as the return motion of the cam permits. The eccentrics are mounted on a horizontal lay shaft which is located to one side of the engine, with its axis parallel to that of the latter, and which is driven by bevel gears from the crank shaft of the engine.

Since this valve arrangement gives short steam and exhaust ports, permits the use of small clearance, and

gives fairly rapid opening and closing of valves with little throttling when open, it gives good economy when used with saturated steam. By adding superheat the economy is still further improved. The water rate of one of these engines is shown for one load in Fig. 134 (a). A simple, Lentz non-condensing engine is reported to have given a consumption of 16.13 lbs. of steam per horse-power hour with 92.7° superheat, and a pressure of 133 lbs., and this figure is materially lowered by compounding, higher superheat, lower back pressure, etc.

93. The Una-flow Engine. A very interesting modification of the steam engine, known as the Una-flow Engine, has recently appeared. In this design an attempt is made to decrease the loss due to condensation in a very original way and the results of tests seem to indicate that the design makes possible very great economy.

In the ordinary forms of engine the entire wall of the cylinder is subjected to the cooling action of the lowest temperature steam during the entire exhaust stroke, and in double-acting types these cooled walls are immediately brought into contact with the higher pressure steam acting on the other side of the piston, as well as coming into contact later with the next charge of high-pressure steam. The una-flow design minimizes this action by admitting steam at the ends of the cylinder, exhausting it at the center of length of the cylinder, and compressing the steam caught in the clearance up to a value approximating initial pressure, thus heating the clearance walls. The heating of the clearance walls is further effected by partly jacketing the head with live steam on its way to the admission valve and the jacket is sometimes extended along the cylinder to the point at which cut-off normally occurs.

One form of this engine is shown in Figs. 138 and 139. The steam enters the cylinder head from below, passes up to a double-seated poppet valve, flows into the cylinder until cut-off occurs and then expands until the piston

uncovers the exhaust ports. The steam is exhausted until the returning piston again covers these ports, after which the material trapped within the cylinder is compressed as indicated in the diagrams. The ideal sought is to maintain each part of the wall approximately at the temperature which the expanding steam will have when reaching it and thus to minimize thermal interchanges and loss.

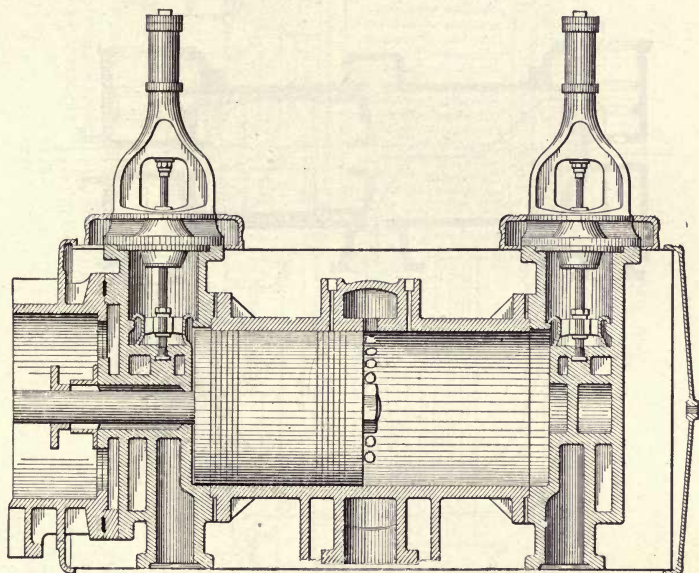

FIG. 138.—Section of Una-flow Engine Cylinder.

Tests of these engines show that very great ratios of expansion can be used in a single cylinder without the excessive losses customary when such ratios are attempted in the ordinary *counter-flow type*. It is thus possible to obtain good economy with one una-flow cylinder expanding from a high pressure to a vacuum; conditions which would involve the use of compounding with ordinary construction.

The results of tests on one of the first Una-flow engines built in this country are shown in Fig. 134 (a) and (b). In comparing with the curves it should be noted that two of the tests were run with high superheat.

94. The Locomobile Type. In the effort to improve the economy of small steam plants the Germans developed a form of plant now known as the **Locomobile Type**. The

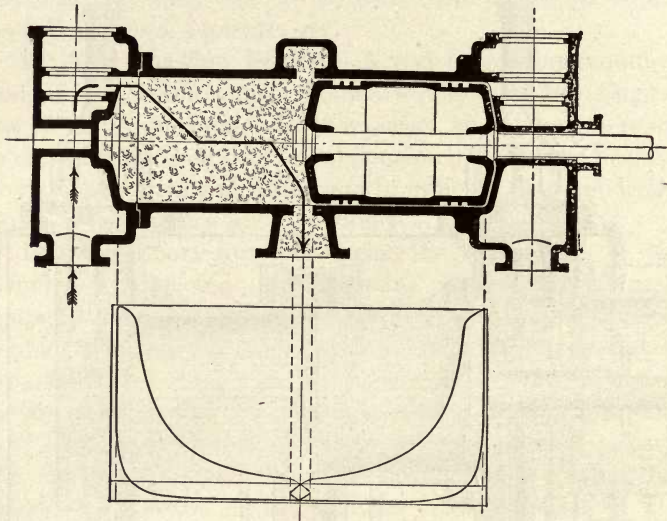

FIG. 139.

name came from the fact that these plants, as originally made, were mounted on wheels and intended for portable use by agriculturists and contractors. Their economy in the use of fuel proved so great that they have since been built for stationary use in sizes running well toward 1000 horse-power per unit.

A locomobile of American construction known as the Buckeye-mobile is illustrated in Fig. 140, which shows a longitudinal section of the plant. The tandem compound

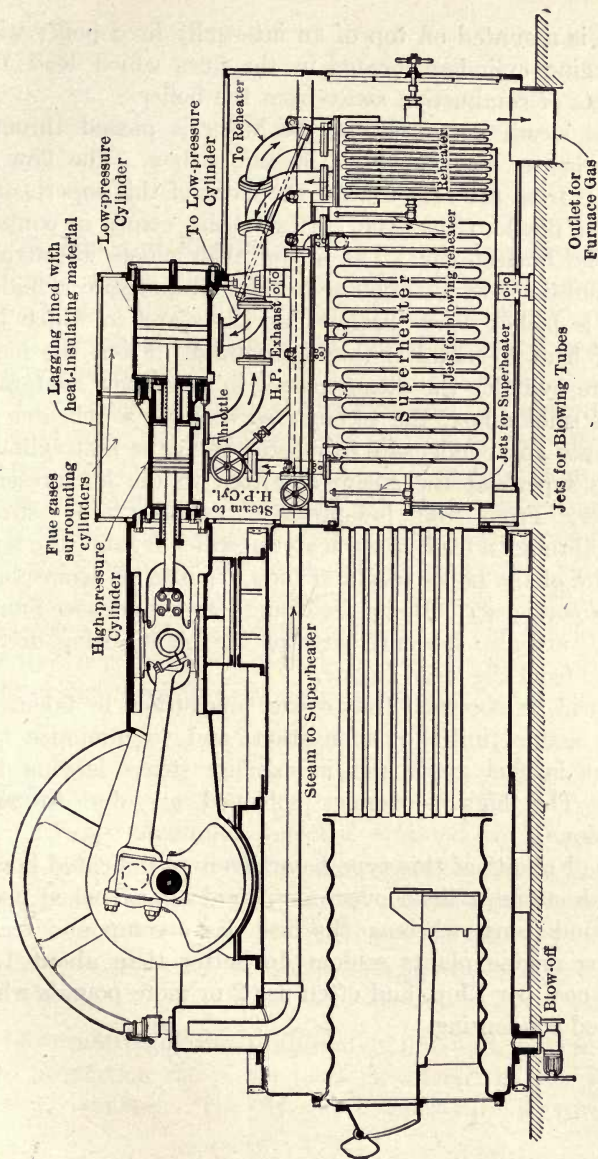

FIG. 140.

engine is mounted on top of an internally fired boiler with the engine cylinders located in the flues which lead the products of combustion away from the boiler.

The steam generated in the boiler is passed through a superheater suspended in the smoke box. The flow of steam is from the rear toward the front of this superheater (counter flow) so that the hottest steam comes in contact with the hottest gas. The steam then passes through a pipe contained within the flue to the high-pressure cylinder, which is jacketed by the hot flue gases and in which the loss of heat to metal is thus minimized. From the high-pressure cylinder the steam passes to a receiver contained in the smoke box, the receiver serving as a reheater to evaporate any condensate exhausted from the first cylinder and to superheat the steam admitted to the low-pressure cylinder. From the low-pressure cylinder, the steam passes through a feed-water heater in which it raises the temperature of the boiler feed and then it passes to atmosphere or to a condenser. Boiler-feed pump and condenser pump, if used, are also integral parts of the plant, being driven directly from the main engine.

It will be observed that every precaution is taken to guard against initial condensation, and to minimize loss of heat in flue gases and in exhaust steam leaving the plant. The high economies achieved are due to such facts alone.

Small plants of this type have given an indicated horsepower hour on a little over one pound of coal when operated condensing, whereas the best large compound reciprocating engine plants seldom do better than about 1.75 lbs. of coal per I.h.p. and often use 2 or more pounds when operated condensing,

CHAPTER XII

REGULATION

95. Kinds of Regulation. There are two distinctively different kinds of regulation referred to in connection with reciprocating steam engines, one of which may be called **fly-wheel-regulation** and the other **governor-regulation** or **governing**.

The regulating effect of the fly-wheel has already been referred to. The turning effort exerted at the crank pin by the action of steam on the piston or pistons of an engine is not constant, and the *angular velocity* of the engine shaft is therefore constantly varying during each revolution. It is the function of the fly-wheel to damp these variations so that they do not exceed the allowable maximum for any given set of operating conditions. The efficiency of the fly-wheel in this respect is measured by the coefficient of fly-wheel regulation δ_W which is defined by the equation

$$\delta_W = \frac{V_{\max} - V_{\min}}{V}, \quad \dots \dots (66)$$

in which

V_{\max} = maximum velocity attained by a point on fly-wheel rim or other revolving part;

V_{\min} = minimum velocity of the same point, and

V = mean velocity of the same point

$$= \frac{V_{\max} + V_{\min}}{2} \text{ approximately.}$$

Governor-regulation is absolutely different. Its function is to proportion the power made available to the instantaneous demand. The fly-wheel takes care of variations

occurring during the progress of one cycle, while governor regulation varies the work value of successive cycles.

96. Governor Regulation. If the effect of engine friction be neglected, the power delivered at the shaft of the engine will vary directly with the indicated horse-power. Such an assumption is accurate enough for the discussion which follows.

The indicated horse-power of a given engine is determined entirely by the value of the mean effective pressure and the number of cycles produced in a given time, since these are the only variables in the formula for indicated horse-power. The power made available by an engine might therefore be varied by varying the mean effective

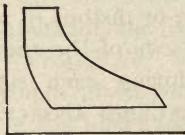

FIG. 141.—Throttling Governing.

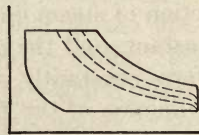

FIG. 142.—Cut-off Governing.

pressure, or by varying the number of cycles produced in a given time, or by a combination of both processes.

All of these possibilities are used. In ordinary stationary power plants the mean effective pressure is generally varied. In the case of pumping engines, working against a constant head, but required to deliver different quantities of water at different times, the number of cycles per minute is generally altered by changing the speed at which the engine operates. In locomotive and hoisting practice both the number of cycles per minute (speed) and the mean effective pressure are varied as required to meet the instantaneous demands.

These variations may be effected manually as by the driver of a locomotive, in which case the engine may be said to be **manually governed**. Or, they may be brought

about mechanically, as in the case of most stationary power-plant engines, in which case the engine may be said to be **mechanically governed**. In some instances a combination of manual and mechanical governing is used.

97. Methods of Varying Mean Effective Pressure. The mean effective pressure increases and decreases with the area of an indicator diagram of constant length, so that the mean effective pressure can be changed by any method which will change the area of the diagram. Two methods are in use and they are illustrated in Figs. 141 and 142. The first causes a variation in area by changing the value of the initial pressure. This is generally done by changing the opening of a valve in the steam line just outside of the steam chest. It is called **throttling governing**, and the valve is called a throttling or **throttle valve**. The latter name is also commonly used for the valve located near the engine, which is used to shut off the supply of steam entirely when the engine is not in operation.

The second method, illustrated in Fig. 142, is known as **cut-off governing**. The variation of cut-off determines the amount of steam admitted to the cylinder per cycle and is used to measure out the quantity required for the load which happens to exist at any instant. Cut-off governing is used on most modern stationary engines and is exclusively used in large reciprocating engine power plants.

98. Constant Speed Governing. Most engines used for such purposes as the operation of mills and the driving of electrical and centrifugal machinery are required to run at practically constant speed irrespective of the load. They are furnished with mechanical governors which so regulate the power made available that there shall never be any appreciable excess or deficiency which would respectively cause an increase or a decrease in speed.

These mechanical devices always contain some sort of tachometer which moves whenever the speed of the engine exceeds or falls below the proper value. The tachometer

is so connected to the valve gear that it decreases the power-making ability of the engine whenever the speed starts to increase and it increases the power-making ability if the speed drops.

Since the valve gear must have a different position for each load in order that it may throttle or cut off as necessary to suit that load, it follows that the tachometer which controls the position of the valve gear must also have different positions for different loads. But tachometers assume positions dependent on speed, and therefore different loads can only be obtained if the tachometer and the engine to which it is connected operate at different speeds for different loads.

Constant-speed governing is therefore an anomaly. The device which is supposed to maintain constant speed irrespective of load must be operated at different speeds, as the load varies, in order that it may maintain the valve gear in the different positions required to handle the different loads. All so-called constant-speed engines have their highest speed when carrying no load, and the speed gradually decreases to a minimum as the load increases to a maximum. The total variation is generally between 2 and 4%.

The efficiency of a governor in this respect is measured by means of the **coefficient of governor regulation**, δ_G , which is defined by the equation

$$\delta_G = \frac{n_2 - n_1}{n}, \quad \dots \dots \dots (67)$$

in which

- n_2 = highest rotative speed attained by the engine;
 - n_1 = lowest rotative speed attained by the engine, and
 - n = mean speed
- = $\frac{n_2 + n_1}{2}$ approximately.

99. Governors. The mechanical devices which are used for controlling the power-making ability of an engine

as described above are known as governors. There are many varieties and only a few of the more prominent can be described.

(a) **The Pendulum Governor.** One of the earliest forms of governor used on steam engines is illustrated in Fig. 143. It is often called a fly-ball governor. This governor is driven by gearing, chain or belt from the engine, and the weights assume some definite position for each different speed, thus drawing the collar to different positions. The valve gear is connected to this collar and is moved correspondingly.

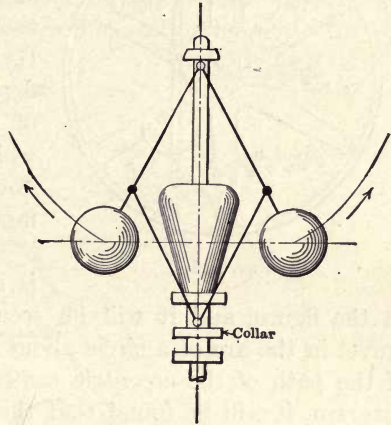

FIG. 143.

A similar governor is shown in Fig. 131, which also indicates the way in which the collar is connected to the valve gear in the Corliss type of engine. The governor rods are moved as the collar moves and they in turn alter the position of the knock-off cam, and thus vary the time at which cut-off occurs. As the speed increases due to a decrease of load, the governor weights and collar move up, and this shifts the cams so as to produce earlier cut-off and decrease power-making ability.

(b) **Shaft Governors.** On medium- and high-speed engines fitted with some form of slide valve it is found best to use what are known as shaft governors. They are generally carried within the fly-wheel of the engine, operate in a plane passing through the rim of the wheel at right angles to the shaft, and operate upon the eccentric in such a way as to vary the cut-off with speed (and load) changes.

One simple form of such a governor is shown in Fig. 144. The eccentric is not mounted directly upon the engine shaft, but is carried

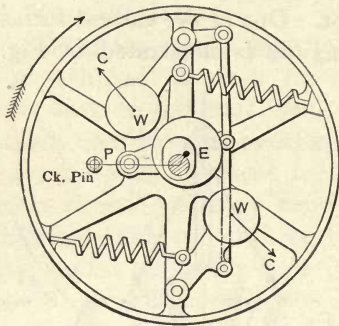

FIG. 144.

by a pin P in the fly-wheel and is slotted so that it can swing back and forth across the shaft, about P as a center. Its position at any time is determined by the position of the governor weights W , which draw the eccentric down (in the figure) as they move out.

The center of the eccentric is indicated by a heavy dot in the figure, and it will be seen that this center would travel in the arc of a circle about P , as the weights moved. If the path of the eccentric center is drawn on a Bilgram diagram, it will be found that this motion is equivalent to decreasing the length of the eccentric crank and increasing the angle of advance, resulting in earlier cut-off as the weights move out with increasing speed and decreasing load. Other events will also be changed as the eccentric swings, and some of these changes are occasionally undesirable.

Numerous designs have been developed in which the eccentric is so guided as to produce various sorts of relations between the different steam and exhaust events. All can be divided into two classes, those in which the eccentric swings about a fixed center variously located, and those in which the center of the eccentric is guided to move in a straight line. All can be studied by plotting the path of the eccentric center (path of Q) on the Bilgram diagram.

The Rites Inertia Governor is a form of shaft governor so designed as to act very quickly with change of speed,

and to be very powerful, so that it can shift heavy parts. It is shown in place in the wheel in Fig. 145. With changes in speed it acts like a governor of the type just described, swinging (with increasing speed) about a fixed point P in the wheel as its center of gravity G moves outward under the action of the centrifugal effect C and against the action of the spring. This motion shifts the center of the

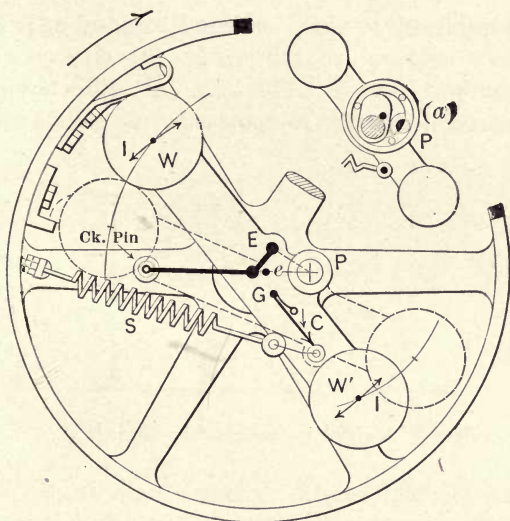

FIG. 145.

eccentric from E toward e , giving the desired variation in cut-off.

Superposed upon this action is that of inertia. Assume the wheel and governor to be rotating clockwise at a given constant speed. If the engine speed is suddenly increased, the wheel will move faster, but the governor bar will tend to continue rotating at the same speed because of its inertia. It will thus lag behind the wheel, rotating about P and bringing about an earlier cut-off. The position thus assumed will later be maintained by centrifugal effect if the new speed

is maintained. The particular advantage resulting from using inertia in this way is speed of action. In many forms of governor the inertia of the moving parts actually resists the efforts of the governor to assume the new position required by changed load and speed.

CHAPTER XIII

THE STEAM TURBINE

100. The Impulse Turbine. One of the oldest of modern water wheels is the tangential or impulse wheel shown diagrammatically in Fig. 146. Water flowing from a reservoir above the wheel passes through a nozzle and the

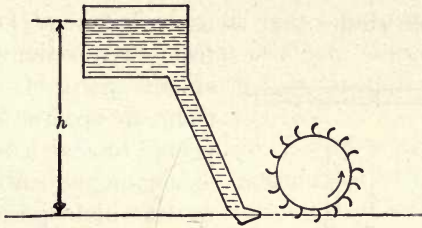

FIG. 146.—Tangential or Impulse Wheel.

jet, moving at high velocity, strikes buckets on the rim of the wheel and causes the latter to revolve. Theoretically the velocity of the water in the jet would be

$$v = \sqrt{2gh} \text{ feet per second, (68)}$$

in which

g = gravitational constant, 32.2, and

h = head in feet as shown in the figure.

The kinetic energy possessed by the moving water would be

$$K = \frac{w}{g} \cdot \frac{v^2}{2}, \text{ (69)}$$

in which w represents pounds of water discharged per second and g and v have the same meanings as above.

If the buckets of the wheel could reduce the velocity of the water to zero they would absorb all of this kinetic energy and (assuming no losses within the buckets and the bearings of the wheel) would make all of it available at the shaft for the doing of useful work.

Any fluid moving at velocity v and striking buckets in the form of a jet would possess kinetic energy in quantity given by Eq. (69) and would drive the wheel in the same way. Steam might therefore be used instead of water with exactly the same results, and steam is so used in what are known as **impulse steam turbines**.

Experience shows that steam will flow at high velocity

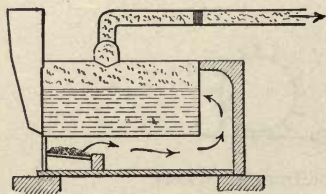

FIG. 147.

from any opening made in the steam space of a boiler or from any open-ended pipe connected to such a boiler. This is commonly said to be due to the high pressure within the boiler, the spectator picturing the process as the driving out of part of the

steam by the high-pressure steam within the boiler, just as though the part leaving were a solid piston and were driven out as is the piston of an engine during admission, as shown in Fig. 147.



FIG. 148.

An hydraulic analogy is given in Fig. 148. The vessel shown is supposed to be fitted with a piston, and it is assumed to be possible to exert any desired pressure upon the piston. Any such pressure exerted is the exact equivalent of some given head of water and the resultant jet velocity would be given by Eq. (68) by substituting for h the head in feet equivalent to the pressure exerted upon the piston.

When an "elastic" fluid such as steam is being con-

sidered it is, however, necessary to take account of other factors. The steam within the boiler exists at a high pressure; after issuing it exists in the atmosphere at a lower pressure. But low-pressure steam contains less heat than does steam at high pressure, and this difference must exist in some form, as it is energy and could not possibly have been destroyed during the flow.

Experiment shows that steam after flowing into the atmosphere from a boiler in this way has exactly the same characteristics as though it had expanded adiabatically behind a piston through the same temperature range, excepting for the fact that it has a very high velocity, which it would not possess if expanded behind a piston. Experiment further shows that, if small losses be neglected, the kinetic energy possessed by a jet of steam is exactly equal to the energy which would be turned into work if that steam acted on a piston as in an ordinary engine.

A complete picture of the process of flow can then be made by assuming the steam flowing out in the form of a piston driven by high-pressure steam, as before, and adding to this the idea that this piston expands adiabatically as it travels from the region of high to that of low pressure. This expansion liberates heat contained within the piston or plug of steam and this heat is used in imparting additional velocity to the moving steam which is giving up this heat.

The result of using such a jet upon a theoretically perfect tangential or impulse wheel would be to rob the jet of all this energy. But the energy possessed per pound of steam in the jet is just the same as that shown under the upper lines of a complete expansion cycle using one pound of steam. The area under the upper horizontal line of the *PV*-diagram of the cycle as shown in Fig. 21 may be assumed to represent the work done upon one pound of steam (flowing out) by another pound which is being evaporated and pushing out the first in order to make room for itself. The

area under the expansion curve in the PV -diagram represents the energy converted into velocity energy by the adiabatic expansion of the flowing steam. The lower horizontal line represents the negative work during condensation to water at the lowest pressure and temperature, and the left-hand line represents the pumping of this water back into the boiler and the raising of its temperature to the value

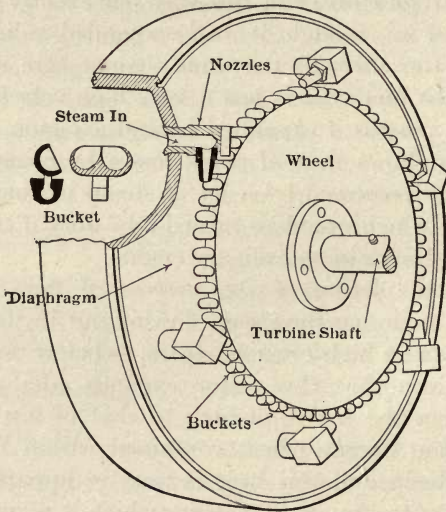

FIG. 149.—Early Form of Impulse Turbine.

maintained within the boiler. The *complete expansion cycle is therefore the cycle upon which the impulse steam turbine operates* and, as a matter of fact, it is the *theoretical cycle of all steam turbines*.

The ideal impulse turbine would therefore be acted upon by a jet which possessed available kinetic energy represented by the area of the complete expansion cycle. If the buckets could entirely remove this energy, that is, could reduce the velocity of the jet to zero, the same amount

of energy could theoretically be made available at the shaft of the turbine.

An example of a simple form of impulse steam turbine is given in Fig. 149, in which the essential parts of an early form of Kerr turbine are shown. The wheel, the diaphragm and nozzles are all inclosed within a casing. The space on one side of the diaphragm is connected to the steam pipe and that on the other is in communication with the space into which the exhaust steam is to be exhausted.

Another form of impulse turbine is shown in Fig. 157. It will be described later.

101. Theoretical Cycle of Steam Turbine. It was shown in the preceding section that the steam turbine operates on the complete expansion cycle. If a turbine could remove from the steam passing through it and convert into mechanical form all of the energy which is theoretically possible, it would therefore make available mechanical energy represented by the area of the PV -diagram of the complete expansion cycle. The area of the corresponding $T\phi$ -diagram would show the same quantity measured in thermal units. The theory of the steam turbine can therefore be studied by means of these two diagrams.

In Fig. 150 is shown the $T\phi$ -diagram of the complete expansion cycle for several different conditions. The figure $abcd$ represents conditions when the steam is dry and saturated at the beginning of the adiabatic expansion cd . Constant quality lines are designated by x and x' . It is obvious that by the time the steam has expanded down to the pressure at d it will have a quality

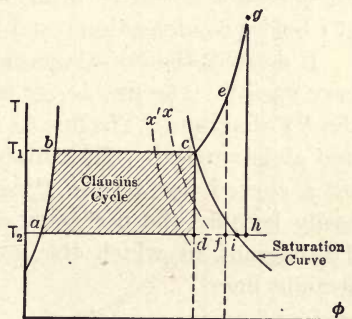

FIG. 150.

less than unity. If, therefore, it be in the form of a jet issuing from a nozzle and having a high velocity by virtue of its adiabatic expansion, the jet will really be a mixture of steam and water.

If the steam be superheated at constant pressure as shown by ce before passing through the nozzle, it is evident from the figure that the jet issuing from the nozzle will contain less water than in the preceding case, because the condition of the material in the jet after adiabatic expansion will be as shown at f instead of as shown at d . The cycle in such a case would also be larger by an amount indicated by the area $cefd$, representing just that much more heat converted into mechanical energy per pound of steam or other unit for which the diagram happened to be drawn.

If superheating had been carried to the point indicated by g before expansion, the jet would obviously issue from a nozzle in the form of superheated steam as shown by the point h in the figure. In that case the cycle would be $abcgha$, and superheat would have to be removed from the low-pressure steam to bring it to the conditions indicated at i before condensation could begin.

If desired, the PV -diagrams for such cycles can be drawn very easily. The line bc , or be or bg is a horizontal line in the PV -diagram. The line ha is similarly horizontal and the line ab is vertical. The adiabatic expansion is represented by a curved line in the PV -diagrams, but can be drawn easily because the necessary data are obtainable from the $T\phi$ -diagram, in which this expansion is represented by a straight line.

ILLUSTRATIVE PROBLEM

Draw the PV -diagram for a steam turbine receiving one pound of steam at a pressure of 200 lbs. absolute. with a temperature of 500° F. and exhausting against a pressure of 0.5 lbs. absolute.

First, locate on a $T\phi$ -chart for steam the point representing the condition of steam at 200 lbs. pressure with a temperature

of 500° F., and draw a vertical line extending downward until it cuts the horizontal temperature line corresponding to

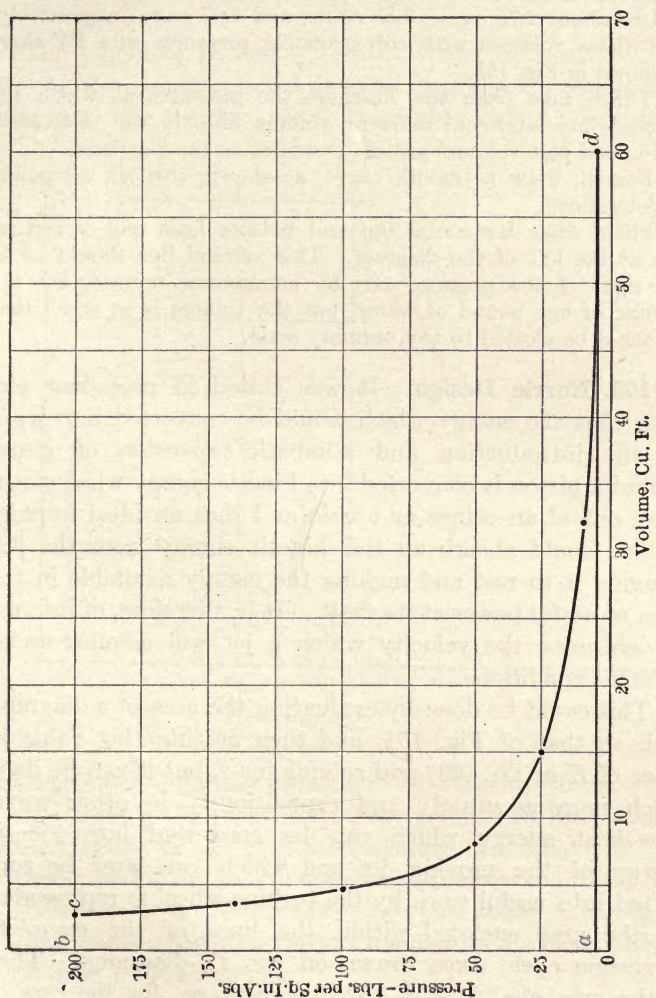

Fig. 151.

0.5 lb. pressure. This is practically at 540° F. absolute, or about 80° F.

Second, take from the steam table the volumes of one pound of steam at, say, 200 lbs., 140 lbs., and 100 lbs. absolute pressure when superheated to the values shown by this vertical line. These will be about 2.75 cu.ft., 3.58 cu.ft., and 4.67 cu.ft., respectively. Plot these volumes with corresponding pressures on a PV -chart as shown in Fig. 151.

Third, take from the $T\phi$ -chart the pressures at which the vertical line intersects different volume lines in the wet steam region and plot volumes against pressures on the $T\phi$ -chart.

Fourth, draw a smooth curve, as shown, through all points so determined.

Fifth, draw horizontal top and bottom lines and a vertical line at the left of the diagram. This vertical line should be to the right of the pressure axis by an amount representing the volume of one pound of water, but the volume is so small that it cannot be plotted to any ordinary scale.

102. Nozzle Design. It was stated in preceding sections that the energy which would be converted into work by the introduction and adiabatic expansion of steam behind a piston is converted into kinetic energy when steam flows out of an orifice or nozzle and that an ideal impulse turbine could absorb all this kinetic energy from the jet, bringing it to rest and making the energy available in the form of useful power at its shaft. It is, therefore, of interest to determine the velocity which a jet will acquire under different conditions.

This could be done by evaluating the area of a diagram, such as that of Fig. 151, and then putting this value in place of K in Eq. (69) and solving for v , but it can be done much more accurately and expeditiously in other ways. The heat energy which can be converted into kinetic energy of the moving jet and which can later be converted into useful work by the turbine wheel is represented by the area enclosed within the lines of the complete expansion cycle when drawn on the $T\phi$ -diagrams. That is the area $abcd$ in Fig. 152, for instance, for the case of wet steam at the beginning of expansion. But this area is equal to that representing the heat supplied minus

that representing the heat rejected, that is, $Q_1 - Q_2$, so that

$$K(\text{in B.t.u.}) = Q_1 - Q_2. \quad . \quad . \quad . \quad (70)$$

The values of Q_1 and Q_2 can be found very readily by plotting the points c and d upon a $T\phi$ -chart for steam and observing the constant heat lines upon which they fall,

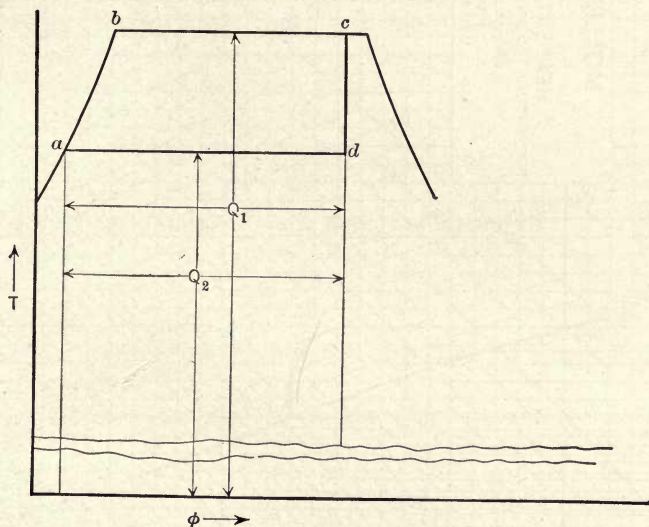
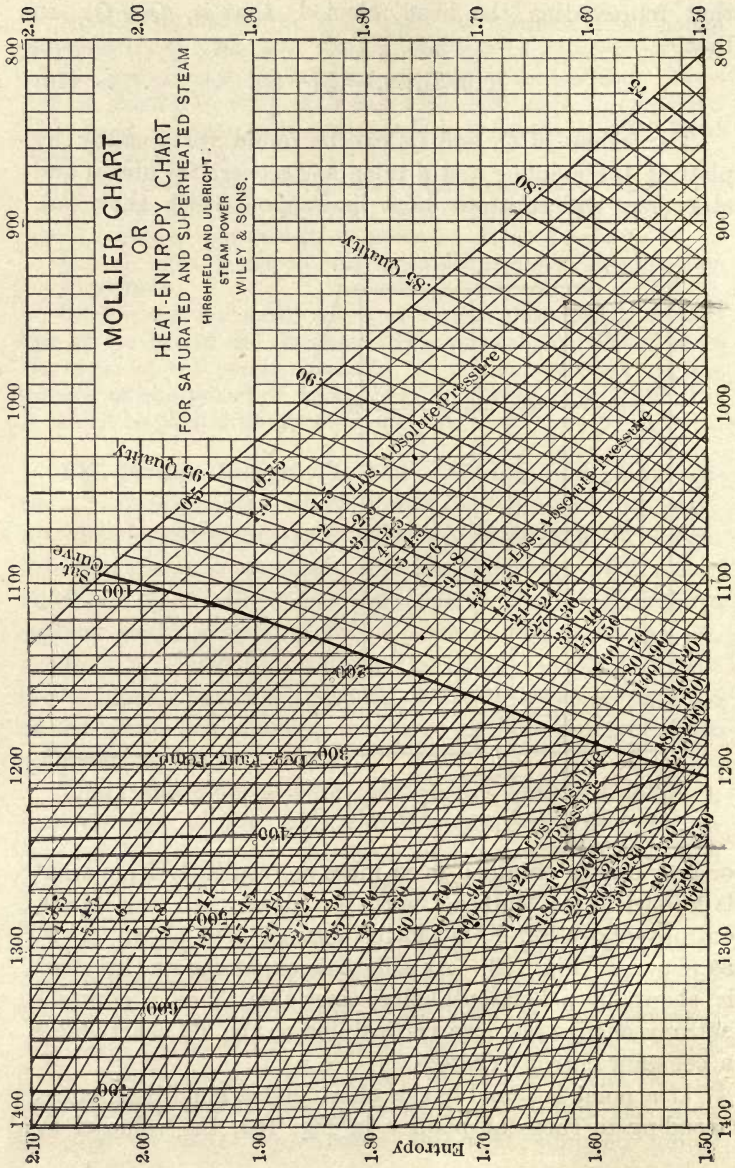

FIG. 152.

or they can be obtained even more conveniently from what is known as a Mollier Chart for steam. In this chart, entropy above 32°F. is plotted against heat above 32°F. as shown in Fig. 153. An adiabatic expansion on this chart is shown by a horizontal line, since this shows a constant entropy change just as a vertical line on the $T\phi$ chart shows a constant entropy change.

If a point is found in this chart giving conditions corresponding to those at point c in Fig. 152, the value of Q_1



B.T.U. Above 32° per Pound of Steam
Fig. 153.

can be read directly under that point on the horizontal axis. A horizontal line drawn from that point to the terminal-pressure line will give the point corresponding to d of Fig. 152 and the value of Q_2 can be read on the horizontal axis immediately below that point. The difference between the two readings gives the value of the kinetic energy K or of the mechanical energy which an ideal turbine could make available, but the expression will be in British thermal units and not in foot-pounds.

This value of the kinetic energy, i.e., $K = Q_1 - Q_2$, may then be placed in Eq. (69), giving,

$$K = 778(Q_1 - Q_2) = \frac{v^2}{2g} \text{ ft.-lbs.}, \quad . . . \quad (71)$$

since Q_1 and Q_2 refer to one pound of steam, or

$$K = 778w(Q - Q_2) = \frac{wv^2}{2g} \text{ ft.-lbs.}, \quad . . . \quad (72)$$

when w represents the number of pounds of steam flowing per second.

Solving either Eq. (71) or Eq. (72) for v gives,

$$\begin{aligned} v &= \sqrt{778 \times 2g(Q_1 - Q_2)} \\ &= \sqrt{778 \times 64.4(Q_1 - Q_2)} \\ &= 224\sqrt{Q_1 - Q_2} \text{ feet per second.} \quad . . . \quad (73) \end{aligned}$$

The design of a nozzle consists simply in choosing such sections that the desired amount of steam may flow through it with the desired pressure drop, as the velocity obviously is determined by that pressure drop. This is very conveniently done by working in terms of one pound of steam, since all formulas and charts are generally given on that basis, and then multiplying the cross-sectional areas found by the number of pounds of steam required.

Assume for instance that it is desired to design a nozzle

to pass one pound of steam per second with an initial pressure of 100 lbs. per square inch abs., and a terminal pressure of 60 lbs., the steam being initially dry and saturated.

The Mollier chart shows that Q_1 is equal to about 1187 B.t.u. per pound of steam, while Q_2 is equal to about 1147 B.t.u. The velocity with which a jet would issue from a theoretically perfect nozzle under these conditions may then be found by using Eq. (73). This gives

$$\begin{aligned} v &= 224\sqrt{1187 - 1147} \\ &= 1416 \text{ feet per second.} \end{aligned}$$

The shape of the entrance end of the nozzle is generally made such that the steam will enter it without great disturbance and the shape beyond that point is determined by methods which will be explained below. The cross-section of the discharge end must be such as to pass the required quantity at the velocity found above to be equal to 1416 feet per second. This is easily done by determining the volume of steam discharged.

Drawing the adiabatic expansion on the $T\phi$ -chart will give the quality at the end of the expansion; or, the quality can be determined by finding what quality a pound of steam at 60 lbs. pressure must have to give it a heat content of 1147 as found above. With the quality known the terminal volume per pound can be found by multiplying the quality by the specific volume at terminal conditions. Thus for the case under discussion the quality will be about 96.7% and as the specific volume at 60 lbs. is 7.17 cubic feet, the volume to be passed per second, per pound of steam is $0.967 \times 7.17 = 6.94$ cu.ft approximately. If the velocity is 1416 feet per second the area per pound of steam must be $6.94 \div 1416 = 0.0049$ sq.ft.

The exact shape of the nozzle is determined by deciding upon the way in which pressure, or velocity, or volume

shall change as the steam passes through it. Suppose, for instance, that a nozzle is to be constructed of the length shown by ab in Fig. 154, and that the pressure is to vary along its length as shown. Assume also that the nozzle is to pass 10 lbs. of steam per second. Taking initial pressure as 100 lbs. and terminal as 60 lbs., the conditions

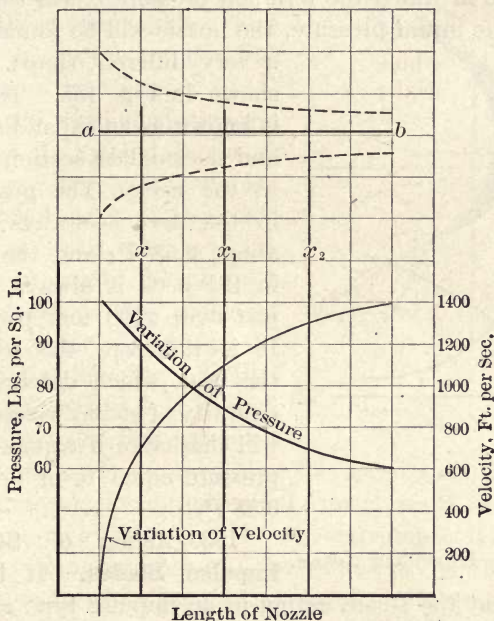

FIG. 154.—Nozzle Design.

will be the same as in the problem above. The discharge area will have to be 10×0.0049 sq.ft. or 0.049 sq.ft.

The area at the plane x_2 must be that required to pass the steam when it has the velocity resulting from expansion from 100 down to 64 lbs., just as though the nozzle ended at that point. This can be found just as the terminal area was found above. Similarly the sections at x_1 and x can be found by figuring velocity and area for expansions to

74 and 90 lbs., respectively. If the various areas required are determined in this way, the nozzle will have a longitudinal section about as shown by the dotted lines in the figure and the variation of velocity will be about as shown by the curve.

If the shape of a nozzle is determined in the same way for a case in which the terminal pressure is less than about 0.58 of the initial pressure, the nozzle will be found to have

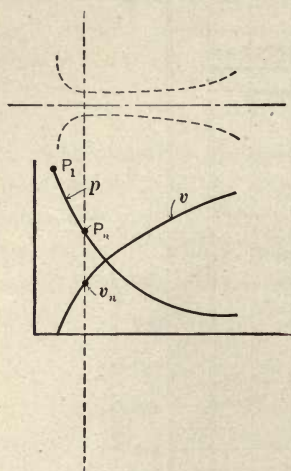

a very different shape. This is shown in Fig. 155. The nozzle is known as an expanding nozzle and the smallest section is known as the neck. The pressure P_n in the neck is always equal to about 0.58 P_1 and the velocity in the neck is always equal to just over 1400 feet per second. It is therefore the section at the neck which determines the quantity of steam which a nozzle will discharge if expanding to a pressure equal to or lower than 0.58 P_1 .

FIG. 155.—Expanding Nozzle.

103. Action of Steam on Impulse Blades. It has been stated that the steam acting in an impulse type of turbine delivers energy to the wheel of the turbine by giving up its kinetic energy. In an ideal turbine the steam jet would be brought to rest and would thus give up all of its kinetic energy.

In real turbines it is impossible to bring the jet to rest, as practical design problems prevent it. There is therefore always a loss in real machines because of the *residual* or *terminal* velocity of the steam as it leaves the wheel. Thus let the black section in Fig. 156 represent the section of a bucket or blade sticking out radially from the rim of a

wheel, the wheel revolving about the axis indicated by the dot dash line but located behind the plane of the paper. If minimum loss by eddying is to be experienced at the point at which the steam jet enters the blade, the jet must enter the blade along a tangent to the curve of the inside of the blade at the entrance edge. This direction is shown by the line marked v_r in the figure.

Were the bucket stationary, the steam jet would move as shown by v_r , but as the bucket moves ahead, and, so to speak, runs away from the jet, the steam must really travel in a direction such as that indicated by v_a in order to strike the bucket in the direction indicated by v_r . The conditions governing the flow of steam into a bucket

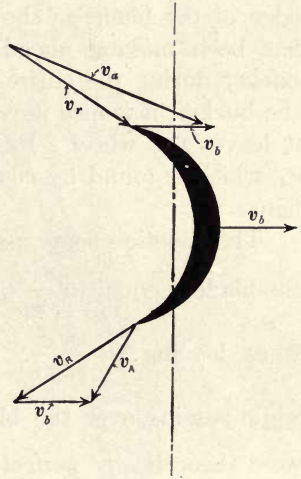

FIG. 156

are the same as those governing the speed with which and direction in which an individual runs toward and jumps upon a moving vehicle. He will experience least shock when he is moving ahead at the same rate as the vehicle at the instant when he gets on board. His motion must therefore be made up of two, one toward the vehicle and the other in the direction of the vehicle's travel.

In the case of steam flowing onto a blade as shown in Fig. 156, the various velocities are so related that when drawn to scale the real or absolute velocity of the steam, v_a , and the real or absolute velocity of the blade, v_b , form two sides of a triangle of which the closing side represents v_r , the velocity of the steam relative to the bucket. The value and direction of v_r is obviously obtained from v_a by geometrically subtracting the velocity of the bucket.

After entrance, the steam flows around the inner curve of the blade and is finally discharged with the same relative velocity as that with which it entered, and at an angle set by the tangent to the inner curvature of the discharge edge of the blade as shown by v_R . But, since the steam has been moving ahead with the same velocity as the bucket during the entire time that it was in contact with the bucket, it is also moving ahead with a velocity v_b when it leaves the wheel. Its real or absolute velocity is then v_A , which is found by combining v_R and v_b as shown in the figure.

The kinetic energy possessed by the jet when entering the blade is equal to $\frac{wv_a^2}{2g}$ ft.-lbs., and that which it possesses when leaving is $\frac{wv_A^2}{2g}$. Obviously, the energy removed while passing over the blade is $\frac{wv_a^2}{2g} - \frac{wv_A^2}{2g}$. If the blade were theoretically perfect, it would be so constructed that v_A^2 would be zero and all of the kinetic energy would then be removed. This is practically impossible in a real mechanism, and there is always a loss due to the residual velocity v_A . The best that can be done is to so choose the angle of jet and blade, and the velocity of blade with respect to the steam that the actual numerical value of v_A is made as small as possible.

Designs usually work out in such a way that this occurs when the blade velocity is equal to about 0.47 of the absolute velocity of the steam jet.

104. De Laval Impulse Turbine. The expanding nozzle already described was first used by De Laval in an impulse type of turbine. The essential elements of this device are shown in Fig. 157. The nozzles are arranged at such an angle to the plane of the wheel that the steam jets strike radially arranged blades at the proper angle to enter without much loss. The blades deflect the jets as shown and

absorb the greater part of their kinetic energy, so that the steam flows away from the wheel with low absolute velocity.

As many nozzles are used as are required to make avail-

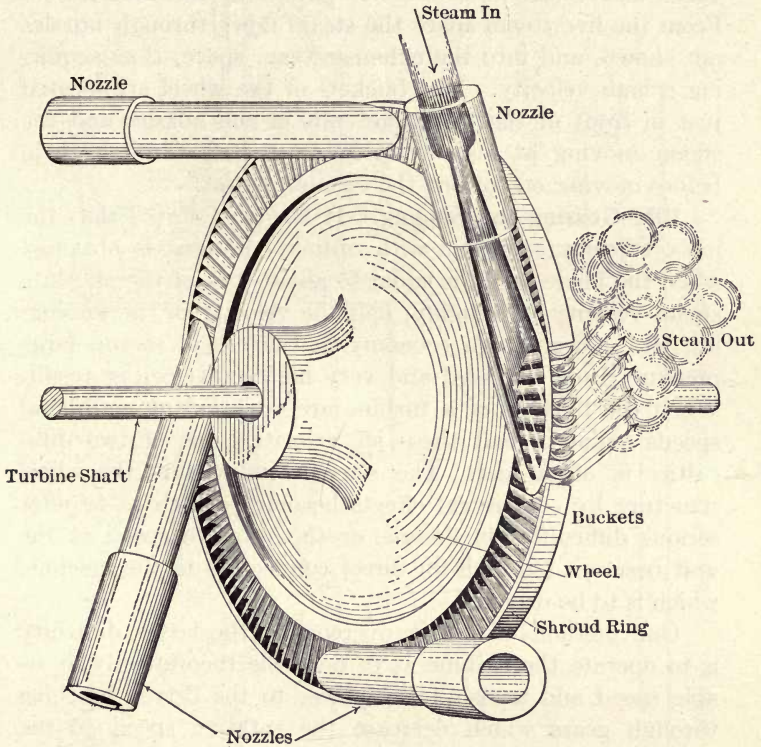

FIG. 157.—Single Stage, De Laval Impulse Turbine.

able the amount of energy desired at full load, and provision is made for shutting off one or more nozzles by hand when conditions do not warrant the use of all. Governing for ordinary variations of load is effected by throttling the steam flowing to the nozzles in use, thus altering the initial pressure as necessary.

A section through the wheel and casing of such a turbine directly connected to a centrifugal pump is given in Fig. 158. The steam flows into the live steam space through a throttle valve controlled by the governor; the valve and connections are not shown in the illustration. From the live steam space the steam flows through nozzles not shown, and into the exhaust steam space, thus acquiring a high velocity. The buckets of the wheel are located just in front of the discharge ends of the nozzles and the steam moving at high velocity must pass through them before moving on toward the exhaust outlet.

105. Gearing and Staging. It has been stated that the most efficient operation with ordinary designs is obtained when the blade speed is equal to about 0.47 of the absolute steam velocity or, roughly, half the velocity of the impinging jet. To get high economy in the use of steam, large pressure drops are used and very high jet velocities result. When the buckets of a turbine are operated at peripheral speeds equal to half these jet velocities one of two difficulties is often met. The stresses induced in the wheel structure by centrifugal effects become so high as to offer serious difficulties in design, or the rotative speed of the unit becomes too high for direct connection to the machine which is to be driven.

One method of partly overcoming the latter difficulty is to operate the turbine at or near the theoretically desirable speed and transmit the power to the driven machine through gears which decrease the rotative speed to the necessary extent. This method was used with all of the early De Laval turbines which were of comparatively small capacity. It is now being successfully applied to marine propulsion and other purposes for which large units are used. It is only a partial remedy in the case of large units, however, as the gears necessary for the desired reduction and the size of the turbine wheels would both become excessive.

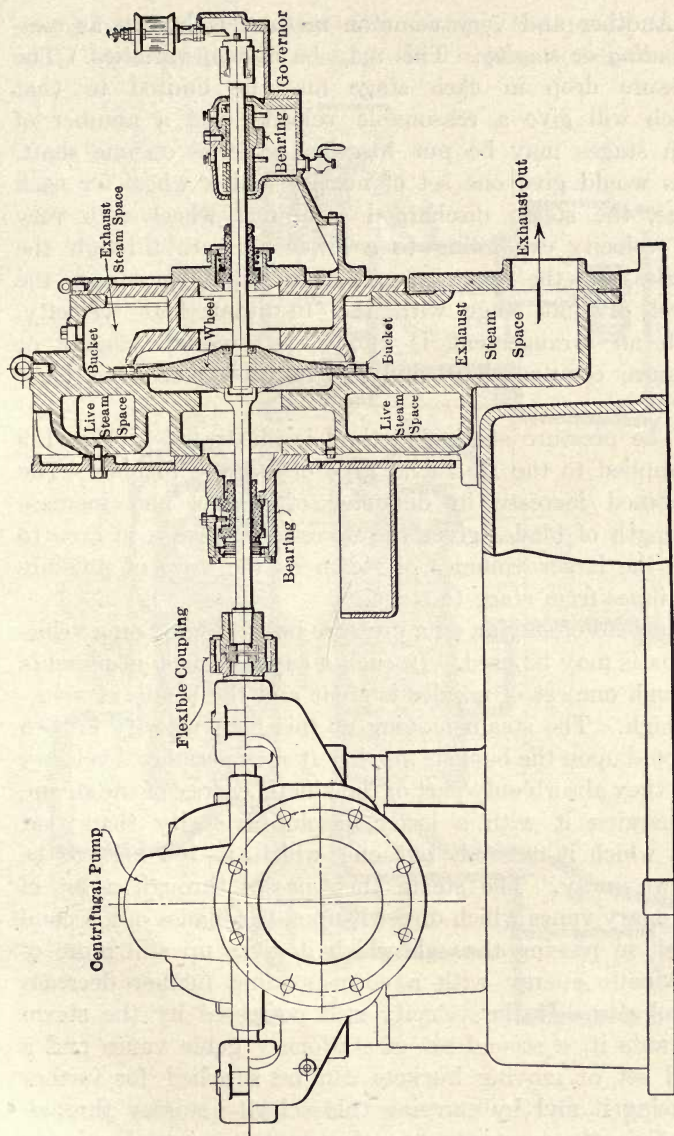

FIG. 158.—Section of De Laval Single Stage Impulse Turbine.

Another and very common method is known as *compounding* or *staging*. This may be of two varieties. The pressure drop in each stage may be limited to that which will give a reasonable velocity and a number of such stages may be put together in series on one shaft. This would give one set of nozzles and a wheel for each stage, the steam discharged from one wheel with very low velocity expanding to a lower pressure through the nozzles of the next stage and impinging upon the wheel of that stage with the resultant high velocity. Such an arrangement is known as pressure staging or pressure compounding, and is extensively used in large turbines.

The pressure staging method is illustrated in Fig. 159 as applied to the De Laval type of impulse turbine. The combined increase in diameter of wheels and increase in length of blades gives the necessary increase in area to pass the larger volumes of steam as the drop of pressure continues from stage to stage.

Instead of staging on a pressure basis, staging on a velocity basis may be used. In such a case the drop in pressure through one set of nozzles is great and the resultant velocity high. The steam moving at this high velocity is then directed upon the buckets moving at such peripheral velocity that they absorb only part of the kinetic energy of the steam, discharging it with a lower absolute velocity than that with which it entered, but one which is too high to be thrown away. The steam then passes through a set of stationary vanes which direct it upon the blades of a second wheel, in passing through which it gives up still more of its kinetic energy with a corresponding further decrease of velocity. If the velocity still possessed by the steam warrants it, a second set of stationary guide vanes and a third set of moving buckets can be supplied for further reducing it and by carrying this velocity staging through a sufficiently great number of stages any initial velocity

could be absorbed theoretically without the use of wheels with high peripheral speeds. Practically, losses due to

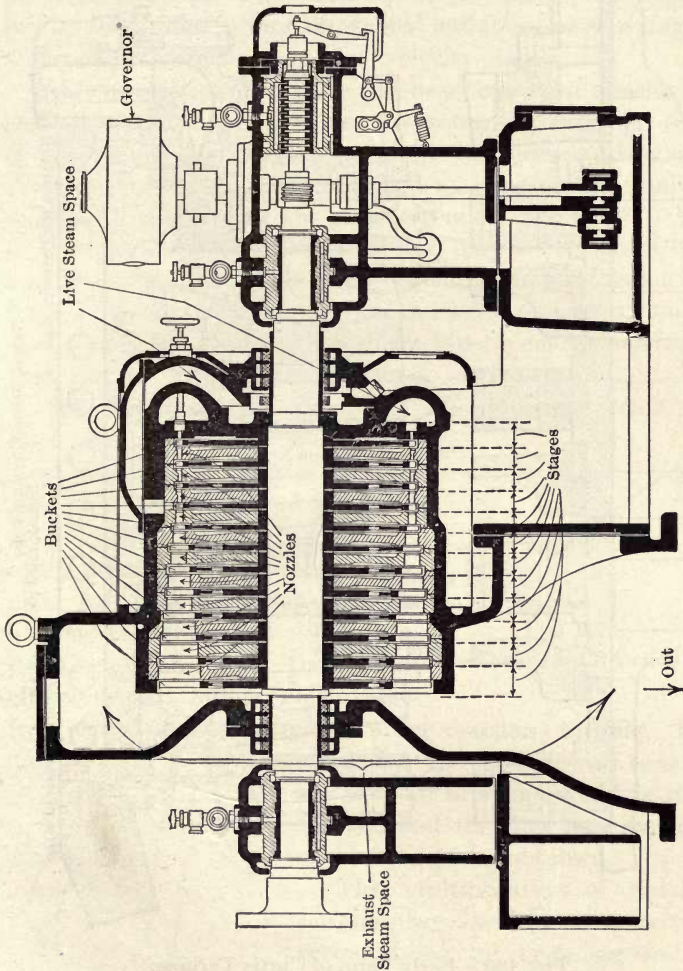

FIG. 159.—Multistage De Laval Steam Turbine.

friction, eddying and other sources limit the number of velocity stages to two or three.

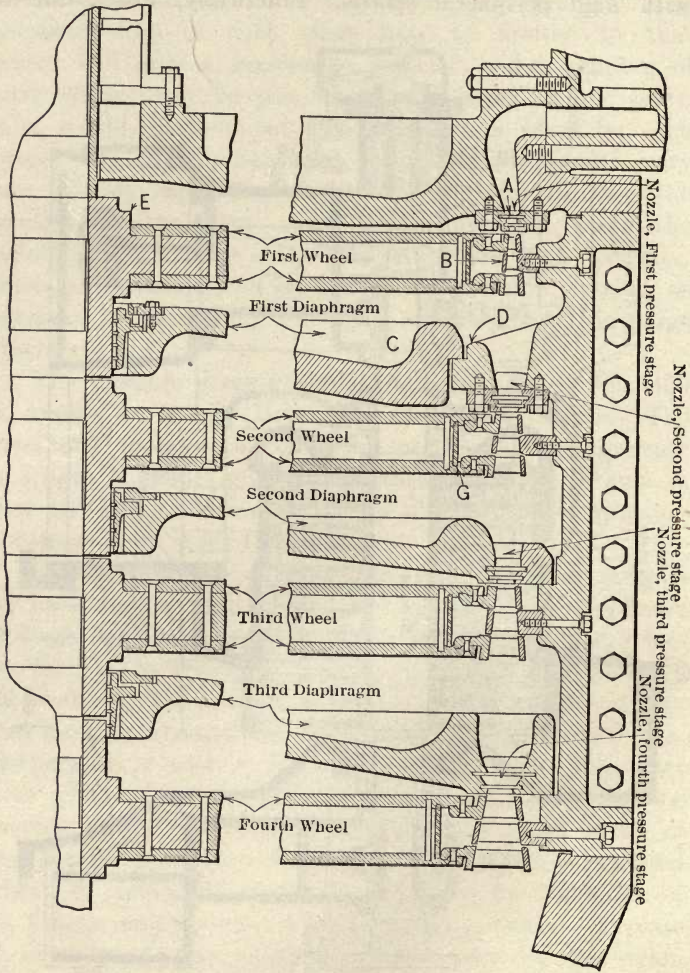

Fig. 160.—Early Form of Curtis Turbine.

Velocity staging is combined with pressure staging in the Curtis type of turbine. A section through part of an early design of vertical turbine of this type is shown in Fig. 160. The turbine illustrated had four pressure stages and each pressure stage had two velocity stages.

Many varieties of impulse turbines have been developed and all of the larger ones employ several wheels and sets of nozzles and diaphragms to obtain the necessary staging. The same result has been obtained in some of the smaller models by discharging the steam from nozzles on to a set of buckets which are able to absorb only a fraction of the kinetic energy, catching it at discharge and returning it for another passage through the buckets, and so on until the greatest practical fraction of the kinetic energy has been absorbed.

106. The Reaction Type. If high-pressure steam or other fluid be forced into a device arranged as shown in Fig. 161 and free to revolve about a vertical axis, the jets blowing out of the nozzles will cause the mechanism to revolve in the direction indicated by the arrow. This rotation is said to be due to the *reaction* of the jets, and the mechanism therefore constitutes a simple form of **reaction turbine**. By

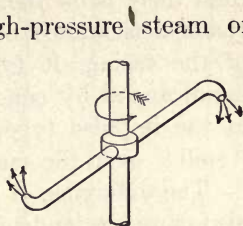

FIG. 161.

Elementary Reaction Turbine.

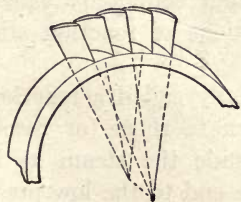

FIG. 162.

increasing the number of nozzles any amount of steam could be discharged and therefore any amount of work could be obtained.

This multiplication of nozzles can, however, be more conveniently accomplished by fastening radial vanes to the periphery of a wheel as shown in Fig. 162, the space

between any two vanes constituting a nozzle through which

the steam can discharge. By mounting such a wheel within a casing as shown in Fig. 163 it forms a **simple reaction turbine**. One of the characteristic differences

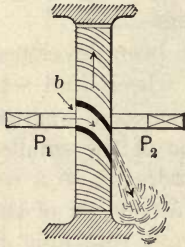

FIG. 163.

between the impulse and the reaction types lies in the distribution of pressures. In the impulse type the nozzles are fastened into a stationary part of the turbine and the drop of pressure occurs entirely within the nozzles. The wheels are therefore immersed in a space in which a uniform, low pressure exists. In the reaction type, on the other hand, the nozzles are carried on the wheel and

there must be a higher pressure on one side of the wheel than there is on the other. Since there must also be mechanical clearance between the blade tips and the interior of the casing, it follows that the reaction type will be handicapped by considerable leakage which does not exist in the impulse type, excepting as some of the jet may "spill" over the ends of the blades.

The difference of pressure on the two sides of the wheel also causes a tendency toward motion of the wheel along the shaft, or of the wheel and shaft, in a direction away from the higher pressure.

Many unsuccessful efforts have been made to design efficient reaction turbines, but no pure reaction type has yet been commercialized. The turbines commonly called reaction turbines are really combinations of reaction and impulse types.

One example of what is commercially called a reaction turbine is shown in Fig. 164. Alternate rings (or rows) of stationary and movable blades guide the steam as it expands from the high pressure at one end to the low pressure at the other. The stationary blades project inward from the interior surface of the stationary casing and the movable blades project outward from the external surface

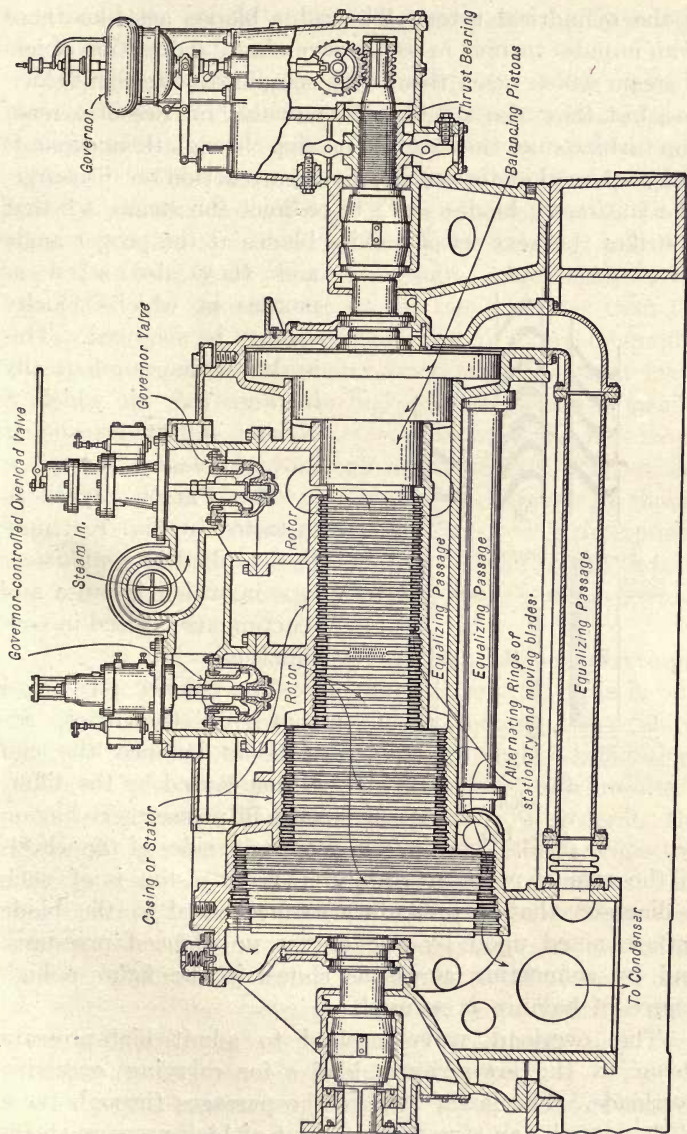

Fig. 164.—Westinghouse-Parsons Steam Turbine.

of the cylindrical rotor. The rotor blades act like those of an impulse turbine in partly reversing the direction of jets of steam which reach them with comparatively high velocities, but they also act like the movable nozzles of a reaction turbine since the steam in passing through them expands and acquires kinetic energy, giving a reaction on discharge. The stationary blades serve to redirect the steam so that it strikes the next set of moving blades at the proper angle

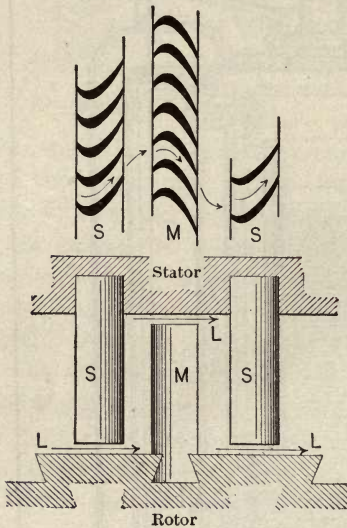

FIG. 165.

and they also serve as nozzles in which velocity energy is acquired. This is shown diagrammatically in Fig. 165, in which *S* denotes stationary, and *M* movable blades.

The Parsons type, illustrated in Fig. 164, may be described as a *multistage type* in which impulse and reaction are utilized in conjunction.

The balance pistons shown in the figure are used to balance the end thrust caused by the difference in pressure existing on opposite sides of the wheels in the case of reaction turbines. Each piston is of such a diameter that it presents a surface equal to the blade surface acted upon by one of the unbalanced pressures, and by connecting across as shown in the figure a high degree of balance is secured.

The overload valve is used to admit high-pressure steam to the low-pressure blades for carrying excessive overloads. The larger area of the passages through these blades permits an abnormal amount of high-pressure steam

to pass, thus giving a high load-carrying capacity with decreased economy.

107. Combined Types. The clearance at the ends of the stationary and moving blades in the Parsons type of turbine permits considerable steam to leak by, as previously explained. This clearance must have almost the same length (measured from blade tip to opposing metal) in all stages in order to insure freedom from rubbing, but it is more detrimental in the high-pressure stages than in the low. The high-pressure blades are much shorter than the low-pressure blades and a leakage length of a certain amount is therefore equal to a greater fraction of the total blade length. The density of the high-pressure steam is also so much greater than that of the low-pressure steam that many more pounds can leak through an opening of a given size in a given time. In discussions of this character, it should not be forgotten, however, that leakage area is determined by the dimension already referred to multiplied into a circumference and that the circumference is much greater at the lower end.

Because of these and other reasons many manufacturers have come to the conclusion that the impulse type is best for the high-pressure end of the turbine and the reaction type for the low-pressure end. Many such combinations have been produced and they are giving very good results.

108. Economy of Steam Turbines. In general, the economies of steam turbines and reciprocating engines are about the same when each type is operated at normal load and under the best conditions. It is probable that very large turbines have a slight advantage over reciprocating engines (as generally built) in the matter of economy and the reverse of this statement appears to be true for most small units, although very economical turbines have been produced in small sizes in the past few years.

The turbine, however, generally gives a flatter water-rate curve than does a reciprocating engine; that is, for

loads each side of the most economical the steam per horsepower hour does not increase above the value attained at most economical load as rapidly in the case of turbines as it does in the case of most reciprocating engines. With a very variable load, therefore, or with a load which is far removed from the rated value, the turbine probably gives a better average performance than does the reciprocating engine. This is particularly true in large sizes.

It has been shown that the *turbine operates on the complete-expansion cycle* and it will be remembered that the *reciprocating engine operates on a cycle with incomplete expansion*. The turbine is therefore able to make better use of very low-pressure steam than can the piston type.

Trial on a $T\phi$ or Mollier chart will show that a turbine receiving steam at about atmospheric pressure and expanding it down to a vacuum of from 28 to 29 ins. should make available as much work as one receiving steam at a high boiler pressure and expanding down to atmospheric. In other words a drop of 100 lbs. or more above atmospheric pressure makes no more energy available than does a drop of about 13 lbs. below atmospheric, or the lower the initial pressure the more heat is converted into work by a given pressure drop. A small decrease in back pressure (terminal or condenser pressure) is therefore very effective in the case of turbines. Tests show that an increase of one inch of vacuum will cause an increase of economy of from 3 to 10 per cent, depending upon the type of turbine and upon other factors.

Experience has shown that reciprocating engines are fully the equal of turbines in the high-pressure ranges, in many cases they are even superior, but the turbine is far superior in the low-pressure region and in cases where very great ratios of expansion are to be used. Advantage has been taken of the superior ability of the turbine to handle low-pressure steam by constructing mixed plants, reciprocating engines being used for expanding down to the neigh-

borhood of atmospheric pressure and turbines expanding the steam exhausted by these engines to the lowest vacuum which can be maintained economically. This system has been found particularly useful for increasing the capacity of a reciprocating-engine plant. The capacity of such a plant can often be almost doubled without any increase in boiler capacity by simply inserting turbines into the exhaust lines between the engines and the condensers, and then arranging the pressures so that the turbines carry the expansion from about 16 lbs. absolute down to a vacuum of from 28 to 29 ins. Turbines used in this way are called **low-pressure** or **exhaust-steam turbines**.

Superheat is also very effective in bettering turbine economy, every ten degrees of superheat generally causing a saving of about 1 per cent in the weight of steam required per horse-power.

The steam turbine is generally cheaper than the reciprocating engine of like capacity if the conditions of operation permit the use of the high rotative speed characteristic of the turbine. It is therefore extensively used for direct connection to blowers, centrifugal pumps and electrical machinery. Most of the larger electric power stations which have been installed within the past few years have used turbines to drive the generators, and single units direct connected to 20,000 K.W. generators are now numerous. Units rated at 45,000 K.W. are also being installed and units of still larger capacity have been designed.

PROBLEMS

1. A steam turbine produces one horse-power hour at its shaft for every 30 lbs. of steam supplied. The initial pressure is 200 lbs. absolute and the steam is superheated 200° F. The turbine exhausts against a back pressure of 14 lbs. absolute.

Find the thermal efficiency on the assumption that heat of liquid at exhaust temperature is not chargeable to the turbine.

2. Develop a complete expansion cycle for one pound of material used under the conditions of Prob. 1 and find the energy

made available per cycle. From this value determine the number of pounds of material theoretically required per horse-power hour and compare with the value given in Prob. 1.

3. Find the additional quantity of energy which would theoretically be made available per pound of steam in above problems if the back pressure could be lowered to $\frac{1}{2}$ lb. absolute.

4. Develop a complete expansion cycle from an initial pressure of 225 lbs. absolute with a superheat of 200° F. to a back pressure of $\frac{1}{2}$ lb. absolute. Assume that this is to be divided up into six parts, each making available the same quantity of energy. Find the pressure drop for each part. Note that this is most easily done with the help of the Mollier chart.

5. A steam turbine receives steam at a pressure of 225 lbs. per square inch absolute and with a superheat of 190° F. and exhausts into a condenser in which a pressure of $\frac{3}{4}$ lb. per square inch absolute is maintained. The turbine is direct connected to an electric generator and produces a K.W.-hour on 12 lbs. of steam. If a K.W.-hour is equivalent to 3411 B.t.u., what is the thermal efficiency of the combination?

6. Develop a complete expansion cycle for the conditions of Prob. 5 and determine the pounds of steam which would be required theoretically to develop energy equivalent to 1 K.W.-hour. Compare with the value given in Prob. 5.

7. Determine the velocity theoretically attainable by expanding steam in one step from the initial to the final conditions of Prob. 5 above. What would be the value of the kinetic energy of such a jet per pound of steam flowing?

8. Determine the shape of a nozzle required to discharge 1000 lbs. of steam per hour, initial conditions being 100 lbs. per square inch absolute, and dry saturated steam; final pressure being 2 lbs. absolute.

9. Determine velocity and kinetic energy of jet in Prob. 8.

CHAPTER XIV

CONDENSERS AND RELATED APPARATUS

109. The Advantage of Condensing. The lowest pressure which can be used in a steam-engine cylinder, that is the exhaust pressure, is determined by the pressure prevailing in the space into which the steam is exhausted. With a given initial pressure the amount of work which can be ob-

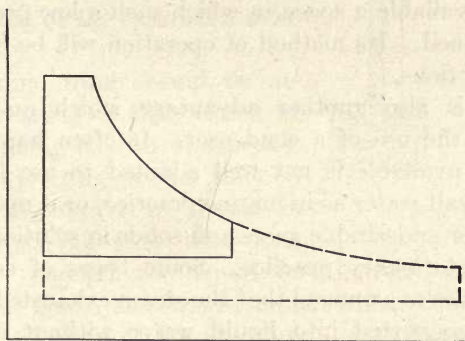

FIG. 166.

tained theoretically from a given weight of steam increases as the exhaust or back pressure decreases, as shown by the areas of the two diagrams in Fig. 166, and experience has shown that at least a part of this theoretical increase can be obtained in real engines. It is therefore desirable to exhaust into a space in which the lowest possible pressure exists when the work obtained per pound of steam is the only consideration.

The most available space into which an engine can

exhaust is that surrounding the earth and already occupied by the earth's atmosphere. The pressure in this space is approximately equal to 14.7 lbs. per square inch at sea level and is due to the weight of the atmosphere. Since the superincumbent column of atmosphere decreases in depth as one moves upward, its weight also decreases and atmospheric pressure therefore averages less than 14.7 lbs. per square inch at high altitudes and has a greater average value at points below sea level.

If it is desired to exhaust into a pressure lower than atmospheric a means of maintaining such an abnormal pressure within some sort of vessel must be devised. It is the purpose of a condenser and its associated apparatus to make available a space in which such a low pressure can be maintained. Its method of operation will be considered in later sections.

There is also another advantage which may be obtained by the use of a condenser. It often happens that the water available is not well adapted to use in boilers. It may be salt water as in marine practice, or it may contain a number of undesirable gases and solids in solution as often occurs in stationary practice. Some types of condensing apparatus are so arranged that the steam exhausted from the engine is converted into liquid water without admixture and can therefore be returned to the boiler as practically pure water, thus largely eliminating the troubles that would ensue from the use of poor feed water.

110. Measurement of Vacuums. Assume that some non-volatile liquid, that is, a liquid that did not vaporize, could be found and also that it contained no gases in solution. If a long tube were inserted in a vessel filled with such a liquid and had its upper end connected with some form of vacuum pump which could remove air from its interior, as shown in Fig. 167, liquid would rise in the tube as the air was removed. Removal of air would result in lowering the pressure within the tube, but the constant

atmospheric pressure on the liquid surface outside the tube would then force liquid up the tube to such a height that the pressure p_a of air in the tube plus the pressure due to the column of liquid of height h within the tube just equaled the pressure due to the atmosphere on the surface of the liquid in the vessel. If the pump could remove all of the air from the tube, liquid would rise to such a height that the pressure exerted by it on a plane passing through the lower surface just equaled that of the external atmosphere.

The same result could be attained by using a tube closed at one end, filling it with the liquid, and then inverting so that the end rested in the liquid as shown in Fig. 168. If the tube were long

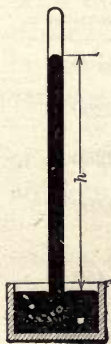

FIG. 168.

enough, the liquid would drop to some such point as shown, under which conditions the height of liquid would just balance atmospheric pressure. This would only be true if the liquid did not volatilize and did not contain gases in solution; with these assumptions the space above the liquid in the tube would contain absolutely nothing. This space would be said to be perfectly vacuous, or a perfect *vacuum* would be said to exist in that part of the tube.

A device of this character is used to measure the pressure of the atmosphere and is known as a **barometer**. Mercury is used as the liquid because its high density makes it possible to use a short tube and because it may be considered

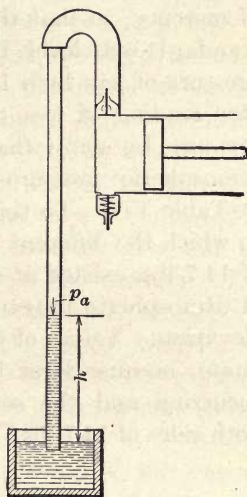

FIG. 167.

as non-volatile at ordinary temperatures. The average atmospheric pressure at sea level, equal to 14.7 lbs. per square inch approximately, can support about 30 ins. of mercury, so that this figure is generally taken as the standard sea level barometer reading. An atmospheric pressure of less than 14.7 lbs. would be shown by a barometer reading of less than 30 ins.; a greater atmospheric pressure by more than 30 ins. Corresponding values of atmospheric pressure and barometer reading are given in Table VII. To this have also been added the altitudes to which the different values would correspond if a pressure of 14.7 lbs. existed at sea level and there were no variations of atmospheric pressure excepting those due to change of elevation. Values of this type can only be roughly approximate, because local barometric variations are constantly occurring and the sea-level atmospheric pressure varies both sides of 14.7 lbs.

TABLE VII

ATMOSPHERIC PRESSURE, BAROMETER READING AND ALTITUDE

(Negative signs mean distance below sea level.)

Barometer, Inches of Mercury.	Atmospheric Pressure, Pounds per Square Inch.	Altitude, Feet (Approximate).
25.00	12.27	4750
26.00	12.76	
26.50	13.01	3250
27.00	13.25	
27.50	13.49	2250
28.00	13.74	
28.50	13.98	1300
29.00	14.23	
29.25	14.35	
29.50	14.47	450
29.75	14.60	
30.00	14.72	Sea level
30.25	14.84	
30.50	14.96	-450
30.75	15.09	
31.00	15.21	-900

The exact value of standard atmospheric pressure at sea level is taken at 29.921 ins. of mercury, which is equal to 14.696 lbs. per square inch and corresponds to the 760 mm. of mercury, used by scientists as standard.

A tube with both ends open and arranged as shown in Fig. 167 can be used to measure the degree of vacuum existing in the space to which its upper end is connected, and many vacuum gauges are constructed on this principle, using mercury as the liquid. The extent to which the pressure is lowered in the top of the tube is indicated by the height to which the mercury column rises and this height in inches is used as a measure of the vacuum. Thus if a perfect vacuum were created and if the atmospheric pressure were equal to 14.7 lbs. the gauge would show about 30 ins. of mercury above the level in the reservoir. If the vacuum were less perfect the gauge would show a shorter column.

It should be noted that the reading of the vacuum gauge does not give the pressure existing in the vacuous space, but gives the amount by which the pressure has been reduced below that of the atmosphere, the difference being expressed in inches of mercury. By subtracting this reading from the existing atmospheric pressure expressed in the same units, the *absolute pressure* in the partially vacuous space (expressed in inches of mercury) is obtained.

It is obvious, therefore, that a vacuum-gauge reading of say 28 ins. of mercury does not always mean the same absolute pressure. With a barometer reading of 28 ins. it would represent a perfect vacuum; with a barometer reading of 30 ins. it would represent a partial vacuum, the absolute pressure in the partially vacuous space being equal to 2 ins. of mercury.

111. Conversion of Readings from Inches of Mercury to Pounds per Square Inch. It is often necessary to convert readings of pressure in inches of mercury into pounds per square inch. This can be done with sufficient accuracy

under ordinary circumstances by multiplying the inches of mercury by the constant 0.4908. Thus,

$$\begin{aligned} \text{Barometer in inches} \times 0.4908 &= \text{atmospheric} \\ \text{pressure in pounds per square inch} & \quad . \quad . \quad . \quad (74) \end{aligned}$$

and

$$\begin{aligned} (\text{Barometer in inches} - \text{vacuum gauge in inches}) \\ \times 0.4908 &= \text{absolute pressure in partially} \\ \text{vacuous space in pounds per square inch.} & \quad . \quad (75) \end{aligned}$$

ILLUSTRATIVE PROBLEM

A vacuum gauge constructed like that shown in Fig. 167 reads 27 ins. when the barometer reads 29.5 ins. What is the absolute pressure in the partial vacuum above the mercury?

The absolute pressure is equal to $29.5 - 27 = 2.5$ ins. of mercury, which is equal to

$$2.5 \times 0.4908 = 1.227 \text{ lbs. per square inch.}$$

112. Principle of the Condenser. A perfect vacuum could be created in any closed vessel with impenetrable walls if a pump could be devised which could remove all material contained within that vessel. Or, any degree of vacuum can be maintained in any partially closed vessel by fitting it to a pump which can remove all material flowing into the vessel as fast or faster than it enters, raise the pressure of this material to atmospheric or higher and discharge it.

The latter principle is made use of in real condensers, a pump of some form, or an equivalent, removing from the condenser the material exhausted by the engine and in-leakage from the atmosphere, and discharging it at atmospheric pressure at a sufficiently rapid rate to maintain the desired vacuum. If the condenser and connections can be made leak proof, the pump or equivalent has to handle only the material exhausted from the engine.

A steam engine exhausts a mixture of steam, water and gases, the gases being a mixture of those originally

dissolved in the boiler-feed water and air which leaks into those parts of the system in which a partial vacuum is maintained. If the pump had to handle the same volume of material as is exhausted by the engine, no gain of work would result from condensing, because the pump would have to do at least as much work in raising the pressure of this material to atmospheric and discharging it as could be obtained by allowing it to expand in the engine.

Steam, however, occupies a much larger volume than water at the same temperature and pressure. Thus steam at 212° F. occupies a volume of about 26.79 cu.ft. per pound, but water at the same temperature and pressure occupies a volume of only about 0.0167 cu.ft. per pound; at a temperature of 120° F. which is often used in condensers, the specific volume of steam is about 203 and that of water only 0.0162. Therefore, if the steam is condensed after exhaust from the engine and before entering the pump to be discharged to atmosphere, the pump work is greatly reduced. The volume of the condensate is almost negligible in comparison with the volume of steam exhausted, and the work of pumping it is almost negligible in comparison with the work it made available in the engine.

Gases contained in the exhaust steam cannot be liquefied and must be pumped as gases. The work required to pump them can, however, be reduced by lowering their temperature as far as possible.

The condenser equipment may be regarded as consisting of a combination of a partially closed vessel and some form of pump. The vessel is so constructed that a low temperature can be maintained within it and that large quantities of heat can be removed from it for the purpose of condensing the exhaust steam and of cooling the contained gases. This is generally done by using large quantities of cool water.

The absolute pressure within the condenser is made up of two parts. The two parts are, (a) that due to the

water vapor, since the space over the condensed water will always be filled with saturated steam at the same temperature (approximately) as that of the water, and (b) that due to any gases present.

The pressure of the saturated steam (water vapor) can be found from the steam tables opposite the temperature existing in the condenser and it is the pressure which would exist in the condenser of an ideal system in which no gases were mixed with the working substance. The pressure of the gases can be found by subtracting from the total measured pressure in the condenser the pressure exerted by the water vapor as shown in the steam tables. The pressures exerted by the water vapor and gases are spoken of as partial pressures, since their sum makes up the total pressure within the condenser.

The presence of gases causes a two-fold loss. First, it increases the pressure against which the engine has to exhaust, thus raising the back-pressure line on the diagram and decreasing the work area. Second, it increases the work which must be done by the pump which otherwise would only pump the condensate and such saturated water vapor as accompanied it.

113. Types of Condensers. The condensers actually used in steam plants can be roughly divided into two types, as

(a) *Contact condensers* and

(b) *Non-contact condensers.*

In the first type the water which is used for condensing and cooling it intimately mixed with the exhaust from the engine within the condensing vessel, and the resultant mixture of condensing water, condensate and gases is drawn out of this vessel and discharged to atmosphere by the pump.

In the second type condensing water flows on one side of metal surfaces of some sort and the exhaust is led over the other side, the heat being transmitted through the

metal. In condensers of this type the condensate and gases are not mixed with the condensing water and the condensate can therefore be returned to the boiler as feed water with the advantages already mentioned.

114. The Jet Condenser. One of the earliest forms of contact condensers which is still very widely used for moderate vacuums is commonly known as the *jet condenser*. The principle of operation of the jet condenser is shown in Fig. 169. Water, under pressure, entering as indicated, is broken up into fine streams or jets and sprayed into the exhaust coming from the engine. The resultant mixture flows downward into the neck of the condensing vessel or "condenser head" and is removed by some form of pump. This pump handles gases, vapors and water and is known as a **vacuum pump**, a *wet-vacuum pump*, or a *wet-air pump*, the term wet signifying that it handles the water as well as the gases.

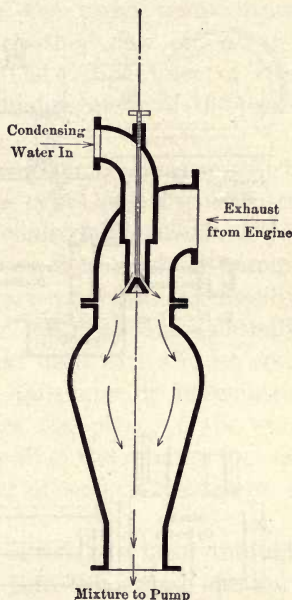

FIG. 169.—Jet Condenser.

The pressure within such a condenser head would be theoretically equal to that corresponding to the temperature of the resultant mixture if no gases were present. In practice the pressure of the water vapor would roughly correspond to the average temperature near the top of the vessel and there would be a partial pressure due to gas as well. This gas would consist of that brought over by the engine exhaust plus that released from the condensing water under the low pressure within the condenser.

Details of a complete jet condenser and of the method of connecting it to an engine are given in Fig. 170. The atmospheric relief valve is installed in all condensing systems and is arranged to open automatically to atmosphere if the pressure within the system rises to atmospheric, that is, if the "vacuum is lost."

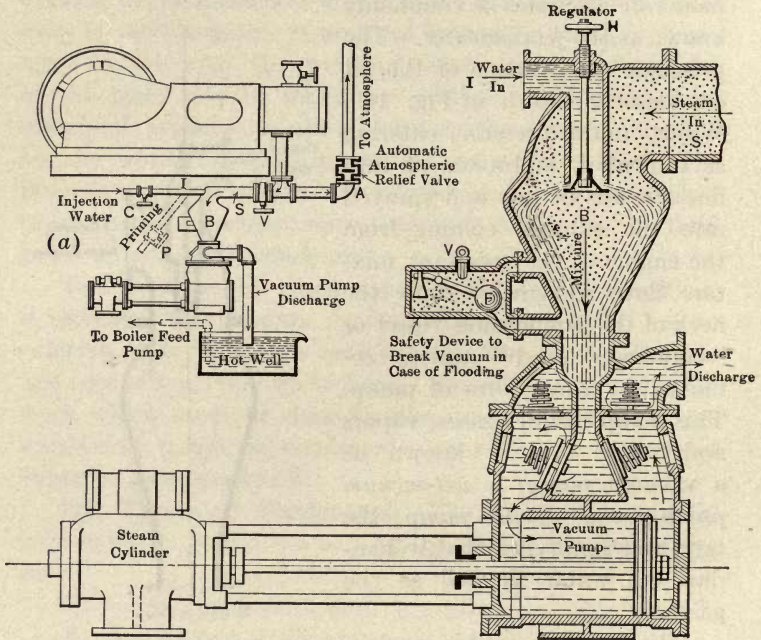

FIG. 170.—Jet Condenser and Method of Connecting to Engine.

With the jet condenser the pressure might start to rise because of slow action or even stoppage of the pump. As the condenser head filled up the rising water would ultimately entirely cover the jet and condensation would then practically cease. In the arrangement shown in Fig. 170 there is an additional safety device which breaks the vacuum in the exhaust system if the water in the head

rises above a certain height, thus preventing the external atmospheric pressure from forcing this water back along the exhaust pipe and into the cylinder, an event which would probably result in a wrecked engine.

The jet condenser here described is known as a **parallel-flow type**, because everything within the condensing vessel flows in the same direction. The gases and vapors handled by the pump theoretically have the same temperature as that of the mixture with which they flow out at the bottom of the condenser head. The temperature of this mixture therefore determines the temperature of the gases and vapors pumped.

There are numerous forms of contact condensers which more or less closely resemble the types of jet condenser just described. They are occasionally all classed as jet condensers, but more often are given distinguishing names.

One very common form of contact condenser is generally known as a **barometric condenser**. It consists essentially of a condenser head, similar to that used with the jet condenser already described, and a tail pipe or barometric pipe which partly or wholly takes the place of the wet-vacuum pump by removing part or all of the mixture formed within the condenser. One model of such a condenser is shown in Figs. 171 and 172.

The exhaust from the engine enters the head through the large pipe shown and divides into two parts, one part passing down through the center of the head and the remainder flowing downward in the annular space *A*. The condensing or injection water enters as shown and is divided by the spraying cone and injected into the engine exhaust, which enters the central tube of the condenser. The mixture thus formed flows downward and finally meets the discharge from the lower end of the annular space *A*, which is then condensed. The mixture of injection and condensing water together with such gases as have been entrapped, then flows downward into the tail pipe, which is

over 34 ft. in length and which dips into the "hot well" at its lower end. As atmospheric pressure can only sup-

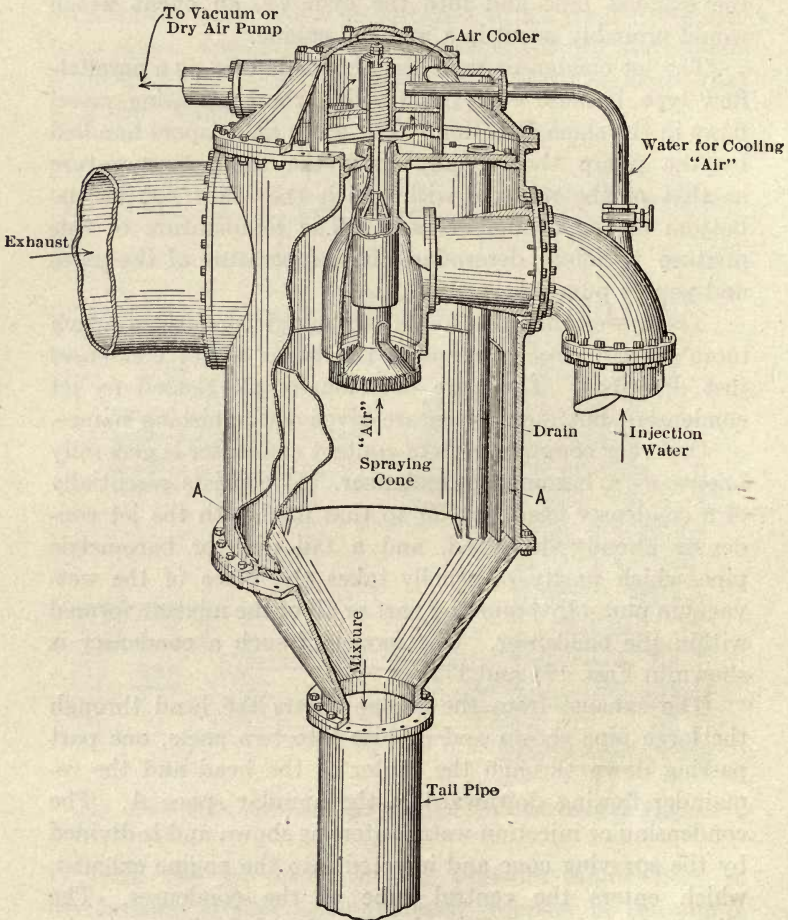

FIG. 171.—Barometric Condenser.

port a column of water about 34 ft. high, the tail pipe forms an automatic wet-vacuum pump, water flowing from it as rapidly as it accumulates within it.

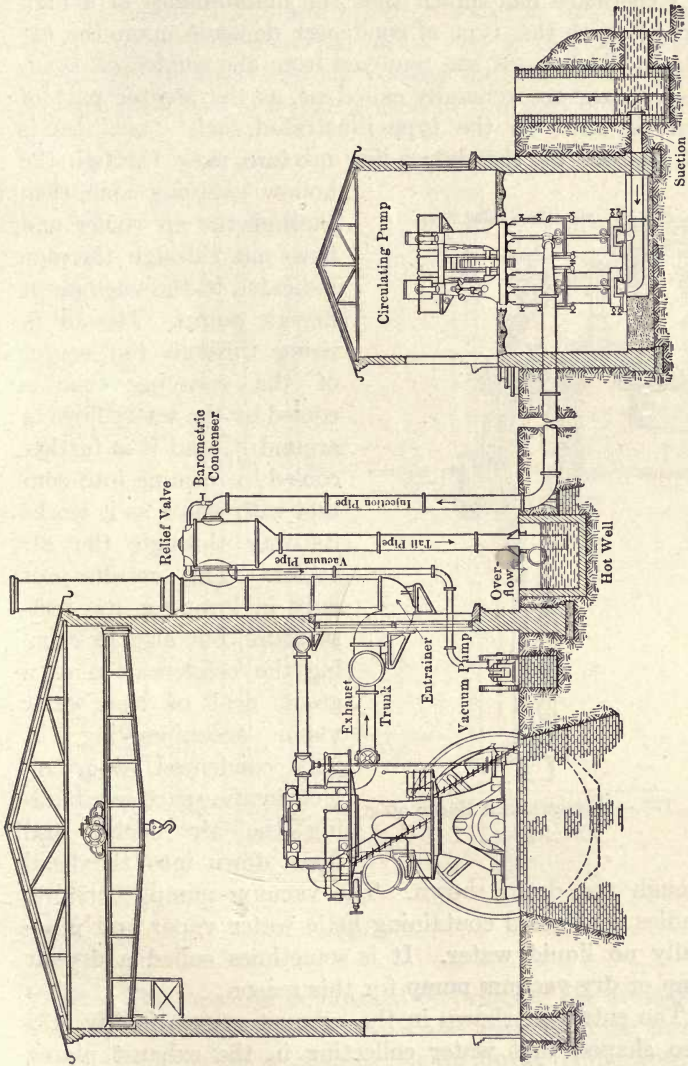

FIG. 172.—Method of Connecting Barometric Condenser to Steam Engine.

Experience has shown that the maintenance of a high vacuum with this type of condenser depends upon the extent to which gases are removed from the condenser head. These gases are generally called air, as the greater part of them is air. In the type illustrated such "air" as is not trapped by the descending mixture rises through the

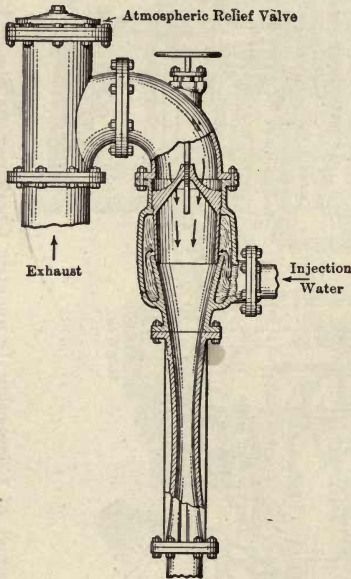

FIG. 173.—Baragwanath Barometric Condenser.

hollow spraying cone, then through the air cooler and flows out through the pipe indicated to the vacuum or dry-air pump. The air in rising through the center of the spraying cone is cooled by the water flowing around it, and it is further cooled by coming into contact with water as it works its way through the air cooler. This results not only in lowering its temperature, but also in causing the condensation of a great deal of the water vapor accompanying it. This condensed vapor collects in the space surrounding the air cooler and flows down into the head through the drain shown. The vacuum pump, therefore, handles cool gases containing little water vapor and practically no liquid water. It is sometimes called a **dry-air pump** or **dry-vacuum pump** for this reason.

The entrainer shown in the exhaust system in Fig. 172 is so shaped that water collecting in the exhaust piping and flowing into the entrainer is picked up by the exhaust steam and carried into the condenser.

The flow of steam and injection water in this condenser is parallel, but the material on its way to the dry-vacuum pump flows upward and the cooling water flows downward so that *counter-current flow* is used in this part of the appa-

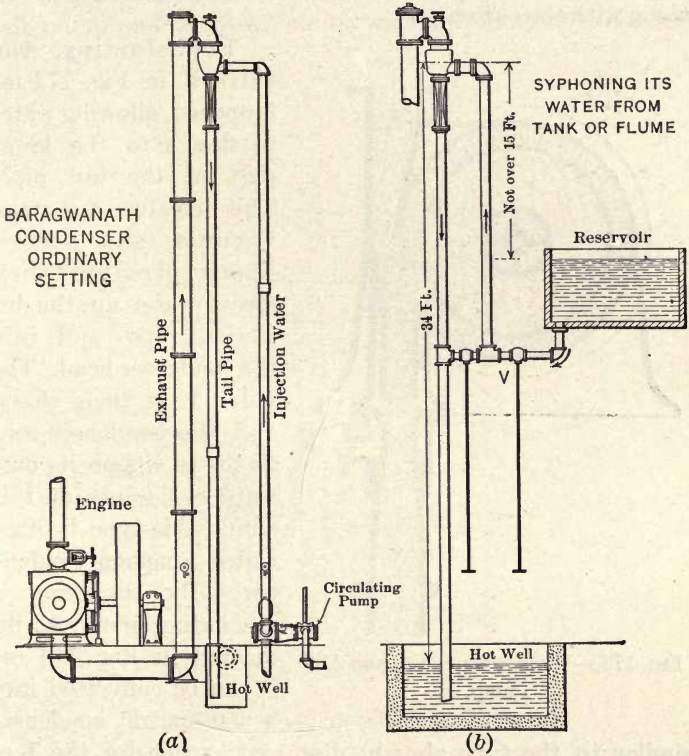

FIG. 174.

ratus. This has the advantage of bringing the *air* leaving the condenser into contact with the cooling water just as it enters and therefore when it has its lowest temperature.

A somewhat similar condenser, arranged so that it requires no pump, is shown in Figs. 173 and 174 (a) and (b).

Exhaust and injection water mix as shown, the quantity of injection water being regulated by the hand wheel on top of the condenser. The mixture flows downward through the narrow neck and the velocity attained in this part of the tail pipe is so high that all air and similar gases are swept along with the current.

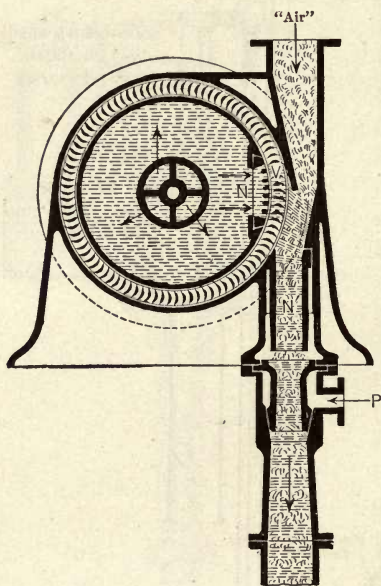

FIG. 175.—Westinghouse-Leblanc Air Pump.

For starting, the valve V in Fig. 174 (b) is opened, allowing water to flow into the lower part of the tail pipe. This creates a partial vacuum, and atmospheric pressure then forces water up the injection pipe and into the condenser head. The valve V is then closed and the condenser continues to siphon its own water. Because of this action this type is often called a **siphon condenser**. By supplying a circulating pump as indicated in Fig. 174 (a) it can be converted into a barometric condenser

similar to the type already discussed except for the fact that it requires no air pump.

The barometric or tail pipe of any barometric condenser can be replaced by any kind of a pump, and centrifugal pumps are often used for this purpose. When large quantities of gas are to be handled, as when a dry-air pump is not used, the centrifugal pump must be specially designed.

A recently developed type of condenser in which the barometric tube is replaced by a centrifugal pump and in which a separate air pump of a rotary type is used is illustrated in Figs. 175, 176 and 177. It consists essentially of the condensing head and well, combined with a centrifugal tail pump and a rotary air or vacuum pump as indicated

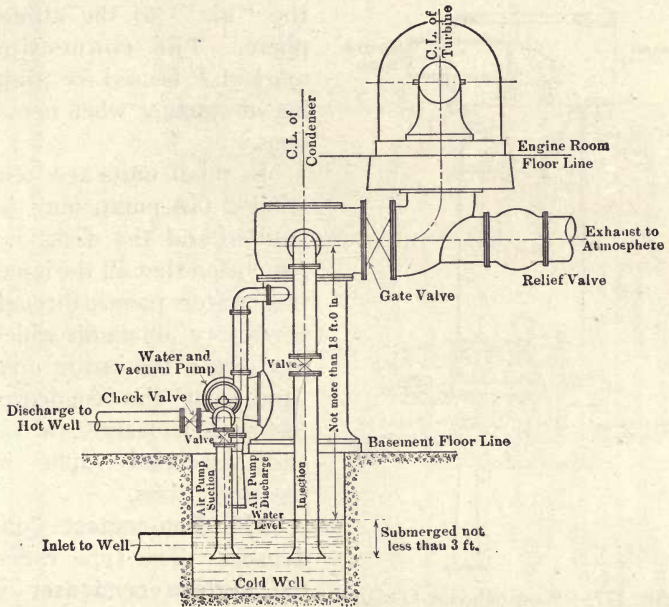

FIG. 176.—Westinghouse-Leblanc Condenser.

in Fig. 177. Injection water entering through nozzles in the head meets the exhaust, and the resultant mixture flows down into the well through the large nozzle shown. The liquid is continuously removed from the bottom of this well by the centrifugal tail pump and discharged to the hot well. The air and associated vapors are drawn down the air pipe and discharged by means of the device shown in

Fig. 175. Water enters the central part of this pump as indicated in Fig. 176 and is discharged through the stationary nozzles *N* and the moving vanes *V* shown in Fig. 175. The water is thus caused to form a series of "pistons" which move rapidly downward in the discharge nozzle *N'* and which trap small plugs or lamina of "air" between them and thus discharge the "air" to the atmosphere. The connection marked *P* is used for priming at starting when necessary.

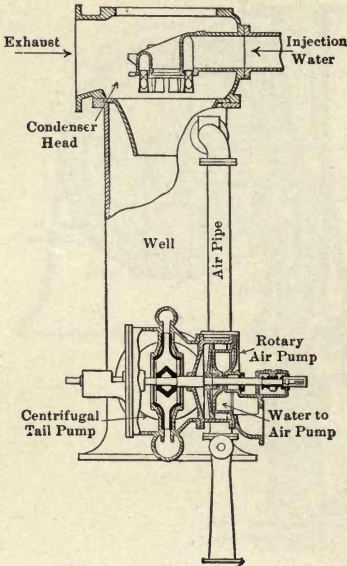

FIG. 177.—Westinghouse-Leblanc Condenser.

In small units the centrifugal tail pump may be omitted and the design so remodeled that all the injection water passes through the rotary air pump which discharges the entire mixture from the condenser just as it discharges the air and associated vapors in the larger sizes.

115. Non-contact Condensers. The type called the **surface condenser** is the best-known example of *non-contact condenser*. It

consists essentially of a large cylindrical or rectangular vessel into which the exhaust is discharged and through which pass numerous bronze or alloy tubes which carry the condensing water, and the surfaces of which act as the condensing and cooling surface.

One form of surface condenser mounted above the pumps which serve it is shown in Fig. 178. The exhaust enters at the top of the rectangular shell and works its

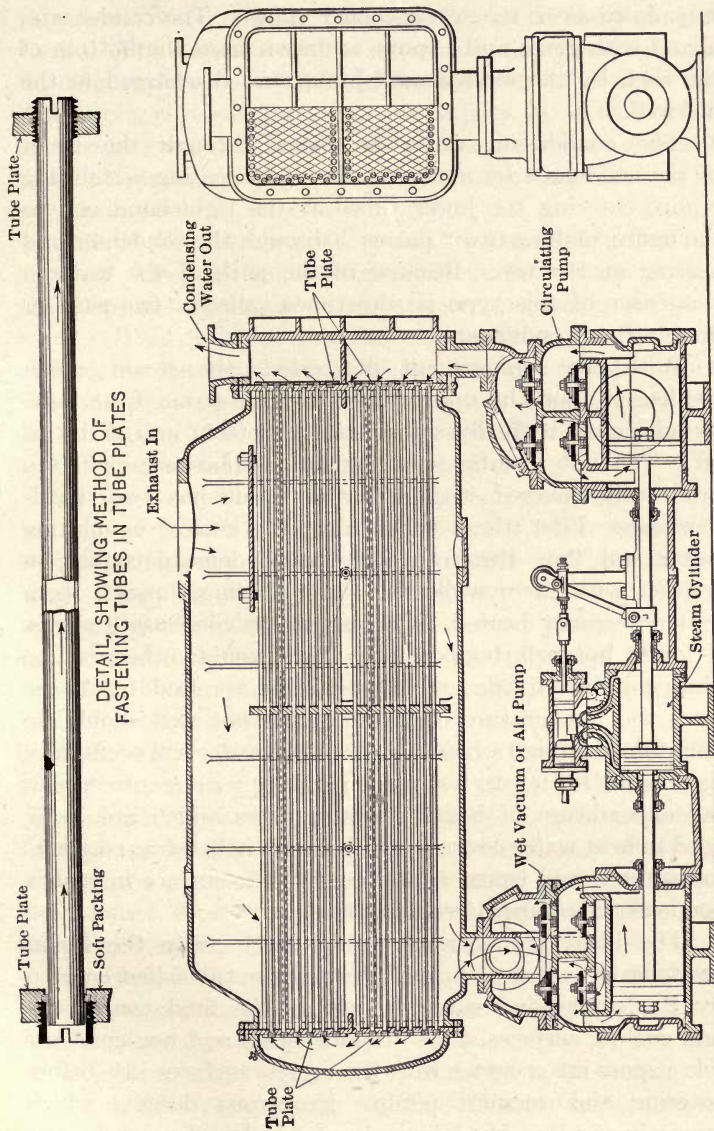

Fig. 178.—Wheeler Admiralty Type Surface Condenser.

way down over the water-cooled tubes. The condensate, mixed with gases and vapors, is drawn from the bottom of the shell by the wet-vacuum pump and discharged to the hot well.

The condensing water is forced through the tubes of the condenser by means of the reciprocating circulating pump, entering the lower tubes at the right-hand end in the figure, making two "passes" through the condenser and leaving at the top. Because of the path of the water a condenser of this type is sometimes called a **two-pass** or **double-flow condenser**.

With the arrangement illustrated, the steam which condenses upon the upper tubes falls as a rain from tube to tube until it finally settles at the bottom and is drawn off. The outer surfaces of the lower tubes are therefore practically covered with water and this has two disadvantages. First, these tubes carry the coolest circulating water and they therefore cool the condensate coming in contact with them while the water flowing through them is unnecessarily heated. Cooling of the condensate means a lower hot-well temperature than would otherwise be obtained, but if the condensate is to be used for boiler feed, the temperature of water in the hot well should be maintained as high as possible, since this water will eventually have to be heated to boiler temperature with a corresponding expenditure of heat. Second, tubes which are being used to heat water covering them are of little use as condensing surface, and hence a large part of the surface in such a condenser is comparatively inactive.

The ideal arrangement would carry away the liquid condensate as fast as formed, leaving the tubes first entered by the condensing water to act as the final condensing and cooling surfaces, thus bringing gases and non-condensable vapors into contact with the coolest surfaces just before entering the vacuum pump. Numerous designs which approximate this ideal have been developed recently and

they give better results than do the earlier and simpler forms. The improvement is shown by the values of condensing surface per developed horse-power of engine. In early designs it was customary to supply $2\frac{1}{2}$ sq.ft. of tube surface or more per horse-power. Some of the most recent installations are giving better vacuums with only 1 sq.ft. per horse-power.

One of the newer models passes the condensate through a set of tubes so located that the engine exhaust strikes them before impinging on any tubes carrying condensing water. This results in a partial condensation of the exhaust and raises the temperature of the condensate within the tubes to very near that of the exhaust, thus heating the boiler feed to a temperature practically corresponding to the exhaust temperature of the engine.

Surface condensers are commonly operated with a vacuum of from 24 to 26 ins. of mercury when used with reciprocating engines and with a vacuum of 28 to 29 ins. when receiving the exhaust of steam turbines. When operated at the lower vacuums wet-vacuum pumps are generally used, but the best types of dry-air pumps must be installed in combination with well-designed condensers when the higher vacuums are sought.

116. Water Required by Contact Condensers. The weight of circulating water required varies with the type of condenser and with the conditions of operation, such as initial temperature of water, vacuum desired, etc. It can be determined approximately by calculation and the values thus found must then be increased by such factors as experience has shown to be necessary.

In contact condensers the water and the condensate are discharged as a mixture and therefore have the same average discharge temperature.

Let t_1 = initial temperature of injection water in F.°;

t_2 = temperature at which mixture is discharged in F.°;

λ = total heat above 32° F. of steam as exhausted;
 W = pounds of injection water per pound of exhaust steam.

Assuming the exhaust steam to be dry saturated, each pound of steam in condensing to water at a temperature of t_2 degrees must give up an amount of heat equal to λ minus the heat of the liquid at t_2 or roughly $\lambda - (t_2 - 32)$ B.t.u. This same quantity must be absorbed by the injection water, while its temperature rises from t_1 to t_2 degrees. Each pound of water can then absorb approximately $(t_2 - t_1)$ B.t.u. and the pounds of injection water per pound of steam will be

$$W = \frac{\lambda - t_2 + 32}{t_2 - t_1} \dots \dots \dots (78)$$

The value of t_2 would be that corresponding to the absolute pressure in the condenser if it were not for the air and similar gases which exert some pressure. It is generally 10 or more degrees F. below the temperature corresponding to the vacuum. Values of t_2 in the neighborhood of 110° to 125° F. are customary with reciprocating engines and values as low as 80° are used with high vacuums in connection with steam turbines.

The weight of water used per pound of steam as given by Eq. (78) will vary between about 15 for very low initial and moderate discharge temperature to about 50 with average initial and moderate discharge temperature. Experience shows that it is necessary to add 10 per cent or more to the values of W obtained from equation (78) to obtain the weight of water which will probably be used.

ILLUSTRATIVE PROBLEM

Find the quantity of water theoretically required per pound of steam condensed in a contact condenser in which a vacuum of 25.5 ins. of mercury is maintained when the barometer reads

29.5 ins. of mercury. The initial temperature of the water is 60° F.

The absolute pressure in the condenser is 29.5 - 25.5 = 4.0 ins. of mercury and the steam tables give for this pressure, λ = 1115.0 and t₂ = 126. Substituting in Eq. (78) gives

$$W = \frac{1115.0 - 126 + 32}{126 - 60} = 15.5 \text{ approximately.}$$

117. Weight of Water Required by Non-contact Condensers. In the case of non-contact condensers there is no definite relation between the discharge temperature of the cooling water and that of the condensate. Experience shows that the discharge temperature of the circulating water is generally from 10 to 20 degrees lower than the temperature corresponding to the vacuum.

The temperature of the condensate (hot-well temperature) is generally 15 or more degrees below that corresponding to the vacuum, but good design makes the hot-well temperature very closely approximate that corresponding to the vacuum.

Assuming

t₁ = initial temperature of injection water in F.°;

t₂ = final temperature of injection water in F.°;

t_c = temperature at which condensate is discharged, i.e., hot-well temperature, in F.°;

λ = total heat above 32° F. of steam as exhausted,

and

W = pounds of injection water per pound of exhaust steam.

The weight of water which must be circulated per pound of steam can be found as in the case of the contact condenser. It is given by

$$W = \frac{\lambda - t_c + 32}{t_2 - t_1} \dots \dots \dots (79)$$

Values in the neighborhood of 25 lbs. of water per pound of steam are common with low vacuums and 50 or more pounds are often used with vacuums over 28 ins. of mercury.

ILLUSTRATIVE PROBLEM

A surface condenser receives circulating water at a temperature of 65° F. and discharges it at a temperature of 80° F. It maintains a vacuum of 28.0 ins. with the barometer at 29.5, and the temperature of the condensate discharged to the hot well is equal to 85° F. Find the quantity of circulating water theoretically required.

This vacuum corresponds to an absolute pressure of $29.5 - 28.0 = 1.5$ ins. of mercury. Assuming this all due to steam (neglecting presence of air) the value of λ may be taken from the steam table as 1100.1 B.t.u. Substitution in Eq. (79) then gives

$$W = \frac{1100.1 - 85 + 32}{80 - 65} = 69.9 \text{ approximately.}$$

118. Relative Advantages of Contact and Surface Condensers. The contact types are as a rule much cheaper than the surface condensers, and they are less subject to serious depreciation, the tubes of surface condensers often corroding seriously in very short intervals of time. On the other hand, the injection of the cooling water into the condensing space in contact types results in the introduction of large quantities of dissolved gases, and much of this material is liberated under the reduced pressure, thus tending to increase the condenser pressure, that is, decrease the vacuum. Where pumps are used to carry away the mixture with contact condensers, these pumps have to handle a much larger quantity of water than the corresponding pump in a surface condenser, and the work of pumping this water out of the vacuum into the atmosphere combined with the additional work required of the pump which handles the "air" may partly balance the advantage of lower first cost of the contact type.

A surface condenser must always be installed where it is desirable to use the condensate as boiler feed, and it is generally used when very high vacuums (low absolute pressures) are to be maintained. The surface condenser is at a serious disadvantage, however, when required to handle the exhaust of reciprocating engines. The exhaust from such engines always contains large quantities of lubricating oil carried out of the cylinder, and unless this material is separated before the exhaust enters the condenser it is deposited on the outer surfaces of the tubes and decreases the conductivity of those surfaces. Such oil can be eliminated to a great extent before the exhaust enters the condenser by means of oil separators, which are generally made up of a series of baffles upon which the steam impinges and upon which the oil is caught.

119. Cooling Towers. The large quantity of circulating water required by condensing plants is often an item of great economic importance. When such plants are located near a river or near tide water, the circulating water can generally be procured for the cost of pumping. When they are located in the middle of cities or in regions where water is scarce, the cost of water may be excessive or it may even be impossible to obtain a continuous supply equal to the demand of the condensers.

In such cases the condensing water is often circulated continuously, being cooled after each passage through the condensers. This cooling is generally done by exposure of a large surface to the air. The resultant evaporation of some of the water with the absorption of its latent heat of vaporization cools the remainder so that it can be used again. This sort of cooling may be effected by running the water into a shallow pond of large area, or by spraying it into the air over a small pond or reservoir or by passing it through a *cooling tower*.

Cooling towers are large wood or metal towers generally filled with some form of baffling devices. The hot water

is introduced at the top and spread into thin sheets or divided up into drops as it descends. Air enters at the bottom and flows upward, cooling the water by contact and by the partial evaporation which results. The circulation of air may be natural, i.e., due to the difference of temperature between the air inside and out, in which case a stack is fitted to the top of the tower; or the circulation may be forced by fans located in the base of the tower. In the latter case the apparatus is called a *forced-draught cooling tower*.

CHAPTER XV

COMBUSTION

120. Definitions. Certain substances are known to chemists as **compounds**, because they can be separated by chemical processes into simpler substances. Thus water and many of the most familiar materials known to man are compounds which can be separated into two or more simpler materials.

Those substances which cannot be further broken up by the processes used in separating compounds are called **elements**; they are regarded as elemental, as the stones of which the compounds of nature are built up. About seventy-five of these elements are now known, but many of them are comparatively rare. Pure metals are all elements; the oxygen and nitrogen which are mixed to form the greater part of the atmosphere are elements; carbon, which forms the greater part of most fuels, is an element.

In many cases the *combination* of elements to form compounds is *accompanied by the liberation of heat*, and some of these combinations are used by the engineer for the purpose of obtaining heat in large quantities. When the elements which occur in fuels, such as coal, wood and petroleum, combine with oxygen, the process is spoken of as **combustion**. The quantity of heat liberated when a pound of any material combines with oxygen (burns) is called the **heat value** or **calorific value** of that material.

Fuels contain a great number of elements, but only three of these ordinarily take part in combustion and are therefore spoken of as combustibles. They are *carbon*, *hydrogen* and *sulphur*. The sulphur content is generally

very small, and the carbon and hydrogen are therefore the most important constituents.

The combustion of each of these elements will be considered in detail in the following sections, but before this can be done two other ideas must be developed.

The smallest particle of an element which can be conceived of as entering into combination to form a compound is known as an **atom** of that element. It has been found that the atoms of each element have an invariable and characteristic mass. The lightest atom is that of hydrogen, and its weight is considered unity. The atom of carbon is twelve times as heavy as that of hydrogen and carbon is therefore said to have an atomic weight equal to twelve. Similarly the atomic weight of nitrogen is fourteen and that of oxygen is sixteen.

The smallest particle which can be formed by the combination of atoms is known as a **molecule**. Like or unlike atoms may combine to form molecules. Thus two hydrogen atoms combine to form a molecule of hydrogen, and hydrogen gas as it ordinarily exists may be pictured as made up of a collection of such molecules. Similarly, gaseous oxygen and gaseous nitrogen may be pictured as collections of molecules which are made up of two like atoms.

When unlike atoms combine to form a molecule, they form a molecule of a compound. Obviously a molecule of any compound is the smallest particle of that compound which can exist.

For convenience, the different elements are represented by abbreviations; thus oxygen is represented by O, nitrogen by N, hydrogen by H, carbon by C and sulphur by S. When these abbreviations are written in chemical equations, such as will be given later, they stand for an atom of the substance. Hence O in a chemical equation would mean one atom of oxygen. The symbol O_2 is used to mean two atoms of oxygen in combination, hence, one molecule

of oxygen. The symbol $2O_2$ means two groups of two oxygen atoms in combination, hence two molecules of oxygen.

The simplicity and elegance of this system will become apparent as the chemical equations which follow are developed and explained.

121. Combustion of Carbon. Carbon can unite with oxygen or burn to form two different compounds—carbon monoxide (CO) and carbon dioxide (CO_2). The monoxide is formed by the combination of one atom of oxygen with one atom of carbon; the dioxide, by the combination of two atoms of oxygen with one of carbon. The dioxide, therefore, contains twice as much oxygen as does the monoxide.

Carbon burned to carbon monoxide has not combined with the largest possible quantity of oxygen, and combustion is therefore said to be *incomplete* in such cases. When, however, carbon dioxide is formed, the carbon has combined with as much oxygen as possible and combustion is said to be *complete*.

It will be shown later that much more heat is liberated when the dioxide is formed than when carbon burns to the monoxide. Hence, *when liberation of heat is the object of combustion*, the process should be so conducted as to result in the formation of the maximum quantity of dioxide and the minimum amount of monoxide.

122. Combustion to CO. The combustion of carbon and oxygen to form the monoxide can be represented by the equation



or by the equation

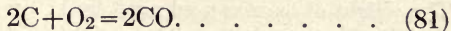

The former is the simpler and will be considered first, but the latter is the more perfect and indicates more to the trained eye than does the simpler form.

The simple equation states that one atom of carbon combined with one atom of oxygen to form one molecule

of carbon monoxide. It can, however, be so interpreted as to show much more than this. *The carbon atom is twelve times as heavy as the hydrogen atom, while the oxygen atom is sixteen times as heavy as that of hydrogen.* The equation

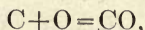

therefore, shows that an atom, which is twelve times heavier than the hydrogen atom, unites with one which is sixteen times heavier than the hydrogen atom to form a molecule which is $28 (= 12 + 16)$ times heavier than the hydrogen atom.

In other words, the weights of carbon and oxygen combining are in the ratio of $\frac{12}{16} = \frac{3}{4} = \frac{1}{1\frac{1}{3}}$. If a sufficient number of carbon atoms to weigh one pound be used, a quantity of oxygen weighing $1\frac{1}{3}$ lbs. will be required to combine with them to form carbon monoxide. The resultant carbon monoxide will contain the pound of carbon and the $1\frac{1}{3}$ lbs. of oxygen and will therefore weigh $2\frac{1}{3}$ lbs.

The same weight relations would hold irrespective of the weight of carbon used, and the simpler equation may therefore be put

$$1 \text{ weight of } C + 1\frac{1}{3} \text{ weights of } O = 2\frac{1}{3} \text{ weights of } CO. \quad (82)$$

ILLUSTRATIVE PROBLEM

To illustrate the use of this equation, assume that 9 lbs. of carbon are burned to carbon monoxide and that it is desired to find the weight of oxygen used, and the weight of the product. The weight of oxygen used must be $1\frac{1}{3}$ times the weight of carbon, that is, $1\frac{1}{3} \times 9 = 12$ lbs. The weight of the product must be $2\frac{1}{3}$ times the weight of the carbon, that is $2\frac{1}{3} \times 9 = 21$ lbs.; or, it must be the weight of the carbon burned plus the weight of the oxygen used, that is, $9 + 12 = 21$ lbs.

In general, the oxygen used for combustion is obtained from the *atmosphere*, which may be considered as a *mechan-*

ical mixture of oxygen and nitrogen in unvarying proportions. These proportions are roughly, 0.23 of oxygen to 0.77 of nitrogen by weight, or 0.21 of oxygen to 0.79 of nitrogen by volume, as shown in Table VIII. The weight of air which contains one pound of oxygen is therefore $\frac{0.23+0.77}{0.23}=4.35$ lbs., and this weight of air contains $4.35-1=3.35$ lbs. of nitrogen.

In the problem previously considered it was found that 12 lbs. of oxygen would be required to burn 9 lbs. of carbon to CO. The total weight of air required to obtain this oxygen will be $12 \times 4.35 = 52.2$ lbs. and it will contain $52.2 - 12 = 40.2$ lbs. of nitrogen.

By simple arithmetical calculations of the type just given all the weight relations involved in the combustion of C to CO can be determined. The volume of air required in any given case can be found by multiplying the weight of air by the specific volume as given in Table VIII. Thus, in the illustrative problem already considered, it was found that 52.2 lbs. of air would be required to burn 9 lbs. of C to CO. The volume of this air at 62° F. would be $52.2 \times 13.14 = 685.9$ cu.ft.

It is found that a quantity of heat equal to about 4500 B.t.u. is liberated per pound of carbon burned to CO; that is the *calorific value of C burned to CO is 4500 B.t.u.*

Returning now to Eq. (81), which was said to be more useful than the simpler form given as Eq. (80), it will be necessary to consider a rather simple law of gases. It has been shown experimentally that *equal volumes of all gases contain the same number of molecules when at the same temperature and pressure.* This statement is known as **Avogadro's Law.** It has also been shown that the molecules of gaseous oxygen contain two atoms.

The equation in question,

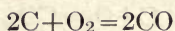

can therefore be read, two atoms of carbon combine with *one molecule of oxygen* to form *two molecules of carbon monoxide*. But, if every molecule of O yields two molecules of CO it follows from Avagadro's law that the CO *formed will occupy twice the volume of the oxygen used* if measured at the same temperature and pressure. If the equation be imagined as containing a numeral 1 before the O₂, it will be obvious that the coefficients of the terms representing gas molecules give volume relations directly. This equation therefore gives both volume and weight relations.

TABLE VIII

PROPERTIES OF AIR

Considering it to consist only of nitrogen and oxygen.

	Relative Proportions.		Ratio of N to O.		Ratio of Air to O.	
	Exact.	Approx.	Exact.	Approx.	Exact.	Approx.
By weight..	{ 0.766 N 0.234 O	{ 0.77 N 0.23 O	3.27	3.35	4.27	4.35
By volume..	{ 0.791 N 0.209 O	{ 0.79 N 0.21 O	3.78	3.76	4.76	4.76

	Spec. wt. at Atmos. Press. (Lbs. per Cu.ft.)		Spec. Vol. at Atmos. Press. (Cu.ft. per Lb.)	
	At 32° F.	At 62° F.	At 32° F.	At 62° F.
		0.08072	0.07609	12.39

Weight of air containing one pound of oxygen is approximately 4.35 lbs.

123. Combustion to CO₂. The combination of carbon and oxygen to form the dioxide is represented by the equation



which shows that one atom of carbon (twelve times heavier than hydrogen) combines with two atoms of oxygen (each sixteen times heavier than hydrogen) to form a molecule of CO_2 , which is forty-four times heavier than an atom of hydrogen. Therefore the weight of carbon and oxygen combining are as $\frac{12}{2 \times 16} = \frac{3}{8} = \frac{1}{2\frac{2}{3}}$, so that $2\frac{2}{3}$ lbs. of oxygen are required to burn a pound of carbon to carbon dioxide. Writing this in the form of an equation, gives

$$1 \text{ weight of C} + 2\frac{2}{3} \text{ weights of O} = 3\frac{2}{3} \text{ weights of CO}_2. \quad (84)$$

The weight of air required can readily be found by multiplying the required oxygen by the number 4.35, previously shown to be the number of pounds of air containing one pound of oxygen. Thus, the required air is $2\frac{2}{3} \times 4.35 = 11.57$ pounds per pound of C burned to CO_2 . This number is commonly rounded out to 12 in engineering literature.

The equation given shows volume relations directly. It is evident, therefore, that one molecule of O yields one molecule of CO_2 , and hence that the volume of the product is exactly equal to the volume of the oxygen used in forming it if measured at the same temperature and pressure. This is a very important relation, and is often made use of in engineering calculations.

Experiment shows that when carbon burns to the dioxide about 14,600 B.t.u. are liberated per pound of carbon burned, that is, the *calorific value of C burned to CO_2* in 14,600.

124. Combustion of CO to CO_2 . Since carbon which has burned to carbon monoxide has not combined with the greatest possible quantity of oxygen, the monoxide can take up more oxygen by burning to the dioxide. This process is represented by the formula



which shows that two molecules of monoxide combine with one molecule of oxygen to form two molecules of the dioxide. The volume of CO_2 formed is therefore equal to that of the CO burned.

So far as the ultimate result is concerned, it makes no difference whether carbon is burned directly to CO_2 or is first burned to CO and then the CO is burned to CO_2 . The total oxygen used per pound of carbon burned to CO_2 and the total heat liberated per pound of carbon burned to CO_2 are the same in both cases.

Thus, for the oxygen, one pound of C burned to CO_2 requires $2\frac{2}{3}$ lbs. of oxygen; but one pound of C burned to CO requires $1\frac{1}{3}$ lbs. of oxygen, and $1\frac{1}{3}$ lbs. more will be required when this CO is burned to CO_2 . The result is therefore the same.

For heat liberated, one pound of C burned to CO_2 liberates about 14,600 B.t.u.; but one pound of C burned to CO liberates about 4500 B.t.u. and 10,100 B.t.u. are liberated when this CO is burned to CO_2 . Since the sum of 4500 and 10,100 is equal to 14,600 the result is again the same.

Data on the combustion of C to CO and CO_2 and the combustion of CO to CO_2 are collected in convenient form in Table IX.

125. Conditions Determining Formation of CO and CO_2 . Excluding certain complicated considerations which are not of great importance in steam-power engineering, it may be said that when carbon is being burned at a certain rate (pounds per unit of time) the amount of oxygen brought into contact with the carbon determines whether the carbon burns to CO or to CO_2 . If enough or more than enough oxygen to burn the carbon to CO_2 is brought into contact, that oxide will be formed. If there is not enough to burn all the carbon to the dioxide, both oxides are formed in certain proportions, which can be calculated.

Since combustion to CO yields only 4500 B.t.u. per

pound of C and combustion to CO₂ yields 14,600 B.t.u. per pound of C, the importance of supplying sufficient oxygen to burn all carbon to the dioxide in cases where the liberation of the maximum quantity of heat is desirable is obvious. In actual practice the oxygen is furnished by supplying air and it is found necessary in most cases to supply more than the amount of air theoretically required in order to insure burning all, or even nearly all, of the carbon to the dioxide. This comes from the great *difficulty met in obtaining contact between the oxygen of the air and the carbon* which is to be burned, that is, in bringing all the oxygen of the air into intimate contact with the fuel being burned in real apparatus.

TABLE IX
COMBUSTION DATA FOR CARBON
(Per pound of carbon.)

Product.	Oxygen Required.		Nitrogen Accompanying Oxygen.		
	Pounds.	Cu.ft. at 62° F. and 14.7 Lbs.	Pounds.	Cu.ft. at 62° F. and 14.7 Lbs.	
CO.....	1.333	16.0	4.46	60.1	
CO ₂ from C.....	2.667	32.0	8.92	120.2	
CO ₂ from CO....	1.333	16.0	4.46	60.1	

Product.	Air Required.		Quantity of Product (N not included).		Heat Liberated.
	Pounds.	Cu.ft. at 62° F. and 14.7 Lbs.	Pounds.	Cu.ft. at 62° F. and 14.7 Lbs.	
CO.....	5.79	76.1	2.33	32.0	4,500 14,600 10,100 per lb. of C in CO 4,300 per lb. of CO
CO ₂ from C.....	11.58	152.2	3.67	32.0	
CO ₂ from CO....	5.79	76.1	3.67	32.0	

The air in excess of that theoretically required to burn all the carbon completely is spoken of as **excess air**. In the form of an equation, this statement is equivalent to

$$\text{Air supplied} - \text{air theoretically required} = \text{excess air.} \quad (86)$$

It is customary to express the quantity of excess air in terms of a numerical factor known as the **excess coefficient**. This coefficient is defined as the *number by which the quantity of air theoretically required must be multiplied to give the quantity of air actually used*. In the form of an equation this gives

$$\begin{aligned} \text{Excess coefficient} \times \text{air theoretically required} \\ = \text{air actually used.} \quad \dots \quad (87) \end{aligned}$$

ILLUSTRATIVE PROBLEM

Taking data from the illustrative problem previously considered, assume that 9 lbs. of carbon are burned in air to CO_2 . Each pound theoretically requires 11.57 lbs. of air, so that the theoretical air-supply for this case would be $9 \times 11.57 = 104.13$ lbs. If in a real case 150 lbs. of air are supplied, the excess coefficient is equal to $150 \div 104.13 = 1.44$.

126. Flue Gases from Combustion of Carbon. The gases resulting from the combustion of fuels are known in engineering as the *products of combustion or flue gases*, because they are the gases passing through the flues or passages leading from furnaces in which fuel is burned and to the stacks which serve to carry off the gases.

It has already been shown that the CO_2 formed by the combustion of carbon has the same volume as the oxygen which is used in forming it. Therefore, if the air supplied in a given case just equaled that theoretically required for combustion to CO_2 and if all of the oxygen were used, the CO_2 formed would *merely replace the oxygen* in the air. The theoretical proportions of the flue gas would then be 0.21 of CO_2 and 0.79 of N by volume,

If real flue gases obtained by burning carbon in air are found to contain less than 21 per cent of CO₂, the combustion has evidently not yielded theoretically perfect flue gases. The trouble may be due to an excess or to a deficiency of air. If there is an excess of air there will be oxygen present in the flue gases; if there is a deficiency there will be CO present in the flue gases. An analysis of these gases for oxygen and for CO would therefore indicate the source of trouble and the remedy to be provided.

The curve to the right of the central vertical line in Fig. 179 shows the theoretical decrease in volume per

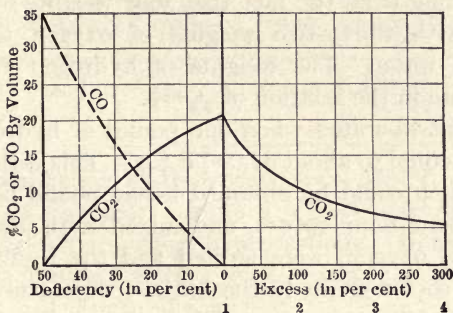
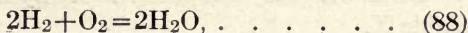

FIG. 179.— Effect of Air Supply on Flue Gas Analysis.

cent of CO₂ in flue gases as the excess air increases. The single numbers 1, 2, 3 and 4 indicate the excess coefficients corresponding to the various percentages of excess air.

The curves to the left give the theoretical decrease in volume per cent of CO₂ and the theoretical increase in volume per cent of CO as the air supplied is decreased below that theoretically required for complete combustion.

127. Combustion of Hydrogen. Hydrogen combines with oxygen, or burns, to form water. The equation for this reaction is



which indicates that two molecules of hydrogen combine with one molecule of oxygen to form two molecules of water. In terms of volumes, two volumes of hydrogen combine with one of oxygen to form two of *gaseous* water, that is, water in the form of highly superheated vapor. As the water is cooled down it will obviously approach and finally reach the liquid condition, with a rapid decrease in volume quite different from that experienced by a gas under similar conditions, so that the volume relations hold only at high temperatures.

The weight relations can be calculated as in other cases, starting from the fact that four weights of hydrogen combine with thirty-two weights of oxygen to form 36 weights of water. The weights of hydrogen and oxygen are therefore in the relation of $\frac{4}{32} = \frac{1}{8}$.

The heat liberated when one pound of hydrogen burns to water is equal to about 62,000 B.t.u. This is the quantity of heat which could be obtained if one pound of hydrogen at, say, room temperature, and mixed with the requisite quantity of oxygen, were ignited and the resultant water were then cooled down to the initial temperature. *During the cooling of the water it would partly or entirely condense and thus give up some or all of its latent heat of vaporization.* This heat would obviously be included in the calorific value just given.

In many pieces of engineering apparatus in which hydrogen is burned the products of combustion are not cooled to such an extent that the water is condensed. The latent heat of vaporization would not be liberated under such conditions, but would remain bound up with the water vapor. *When the water is not condensed* the heat liberated is only about 52,000 B.t.u. per pound of hydrogen. This number is known as the *lower calorific value* of hydrogen, while 62,000 is known as the *higher calorific value*.

Data on the combustion of hydrogen are given in Table X.

TABLE X
COMBUSTION DATA FOR HYDROGEN
(Per pound of hydrogen)

Product.	Oxygen Required.		Nitrogen Accompanying Oxygen.	
	Pounds.	Cu.ft at 62° F. and 14.7 Lbs.	Pounds.	Cu.ft. at 62° F and 14.7 Lbs.
H ₂ O	8	96	26.8	361

Product.	Air Required.		Quantity of Product (N not included).		Heat Liberated.
	Pounds.	Cu.ft. at 62° F. and 14.7 Lbs.	Pounds.	Cu.ft. at 62° F. and 14.7 Lbs.	
H ₂ O	34.8	457	9	Liquid 0.144	{ 62,000 52,000

128. Combustion of Hydrocarbons. Many of the fuels used by the engineer contain *compounds of hydrogen and carbon* which are called **hydrocarbons**. One of the best examples is *methane* (CH₄), which forms the greater part of all the so-called natural gas.

All of these hydrocarbons burn to CO₂ and H₂O if the supply of oxygen is great enough. If there is a deficiency of oxygen, combustion is incomplete and generally results in the formation of CO₂, H₂O, CO, C in the form of soot, and other products which need not be considered here.

For complete combustion the requisite oxygen and air can be determined as in previous cases by means of chemical equations. Thus for methane the equation is

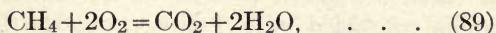

which shows that sixteen (12+4) weights of methane combine with sixty-four (2×2×16) weights of oxygen to form forty-four (12+32) weights of carbon dioxide and thirty-six (4+32) weights of water.

The calorific value of hydrocarbons is generally assumed to be equal to the sum of the heat values of the carbon and hydrogen contained in one pound of the material. Thus, if C represent the fraction of a pound of carbon contained in one pound of the hydrocarbon and if H represent the fraction of a pound of hydrogen contained therein, the common assumption would make the higher calorific value of the hydrocarbon

$$(C \times 14,600) + (H \times 62,000) \text{ B.t.u.} \quad . \quad . \quad (90)$$

The results obtained in this way do not generally check well with the experimentally determined values, and it is best to use the latter when they are available.

129. Combustion of Sulphur. Sulphur forms several different oxides, but when burned under engineering conditions it is generally assumed to form only the dioxide SO_2 . The chemical equation for such combustion is



and since the atomic weight of sulphur is 32, this equation shows that equal weights of sulphur and oxygen combine to form the dioxide.

The combustion of sulphur to SO_2 liberates about 4000 B.t.u. per pound of sulphur.

130. Combustion of Mixtures. It is often necessary to obtain approximate calorific values of combustible materials which, without great error, can be considered as mixtures of combustible and non-combustible elements. If there is oxygen present in the mixture it is assumed to be combined with hydrogen in the form of water, so that the *uncombined* or *available hydrogen* per pound of material is given by the expression

$$\text{Available H} = \text{H} - \frac{\text{O}}{8}, \quad . \quad . \quad . \quad . \quad (92)$$

in which H and O respectively represent the fractions of a pound of hydrogen and oxygen in one pound of material.

The calorific values of such a mixture containing carbon, hydrogen and sulphur would then be given approximately by the equation

$$\text{Higher B.t.u.} = 14,600C + 62,000\left(H - \frac{O}{8}\right) + 4000S, \quad (93)$$

in which the letters stand respectively for the fractions of a pound of each of the elements present in one pound of the mixture. Similarly the lower calorific value would be (approximately)

$$\text{Lower B.t.u.} = 14,600C + 52,000\left(H - \frac{O}{8}\right) + 4000S, \quad (94)$$

and the oxygen required will be

$$\text{Pounds of O} = 2\frac{2}{3}C + 8\left(H - \frac{O}{8}\right) + S. \quad \dots \quad (95)$$

131. Temperature of Combustion. If combustion of any material could be carried on inside of an ideal vessel which did not absorb nor transmit heat, the heat liberated during the combustion could not escape from the space within the vessel.

If the vessel contained initially only the combustible and the oxygen or air required to burn it, the products of combustion would be the only material contained within the vessel after the completion of combustion. Under such circumstances the heat would be used in raising the temperature of the products of combustion, and the process could be pictured as though all of the combustion occurred first, forming the products of combustion without change of temperature, and then the liberated heat raised the temperature of these products.

Knowing the weight of each of these products and the quantity of heat required to raise the temperature of one

pound of each of them one degree, the amount of heat required to raise all of them one degree could be found by multiplying the two known values. Thus, if carbon had been burned in oxygen to CO_2 with the theoretical oxygen supply, the vessel would contain only carbon dioxide. To raise the temperature of one pound of carbon dioxide one degree requires an amount of heat equal to the specific heat of that gas. Therefore, if W represents the weight of CO_2 formed and C represents its specific heat, the amount of heat required to raise the temperature of all of the CO_2 one degree would be $W \cdot C$ B.t.u. If Q B.t.u. were liberated by the combustion, the *temperature rise* in degrees would therefore be given by

$$\text{Temp. rise} = \frac{Q}{WC}, \quad \dots \dots \dots (96)$$

and if the initial temperature had been t_0 degrees, the *final temperature* would be

$$t = t_0 + \frac{Q}{WC}, \quad \dots \dots \dots (97)$$

A final temperature figured in this way is called the **theoretical temperature of combustion**. It can never be attained in practice because of heat lost to surroundings and because of other losses which need not be considered here.

Theoretical temperatures of combustion are, moreover, nearly always calculated on the assumption that the *specific heats of gases* are constants, whereas they really *increase with the temperature*. It therefore follows that temperatures determined on the assumption of constant specific heat will be too high for this reason also.

When gases are heated there are two distinctly different limiting possibilities; the volume occupied by the gases may remain constant or the pressure exerted by the gases may remain constant while the volume increases. In the case of constant volume all the heat added to the gases

must be used for raising the temperature; the amount of heat required per pound per degree under these conditions is known as the specific heat at constant volume and is designated by C_v .

When, however, the volume is allowed to increase at such a rate as to keep the pressure constant the heat supplied must not only raise the temperature, but must also do whatever external work is done in displacing (pushing out of the way) surrounding mediums. The heat required per pound per degree under these conditions is known as the specific heat at constant pressure and is represented by C_p . It is always greater than C_v by the amount of heat required to do the external work accompanying a rise of temperature of one degree.

Thus, in the case assumed above, had the vessel been so constructed that its internal volume did not change, the specific heat at constant volume would be used. On the other hand, had the vessel been fitted with a movable piston arranged to move outward at such a rate as to maintain constant pressure within the vessel as the temperature rose, the specific heat at constant pressure would be used.

In most cases the material burned is not pure carbon, but a fuel containing carbon, hydrogen and sulphur, and as air is generally used to furnish the oxygen, the products of combustion will contain not only the oxides of carbon, hydrogen and sulphur, but inert nitrogen as well. The temperature rise is determined in the same way, however, by dividing the heat liberated by the amount required to raise the temperature of the products one degree. Thus if $W_1, W_2, W_3 \dots W_n$ stand for the weights of the various products and $C_1, C_2, C_3 \dots C_n$ for their respective specific heats, the *theoretical temperature rise* is given by

$$\text{Temp. rise} = \frac{Q}{W_1C_1 + W_2C_2 + W_3C_3 + \dots + W_nC_n}, \quad (98)$$

and the *theoretical temperature of combustion* is given by

$$t = t_0 + \frac{Q}{W_1C_1 + W_2C_2 + W_3C_3 \dots W_nC_n} \quad (99)$$

if t_0 stands for the initial temperature.

PROBLEMS

1. Assume 10 lbs. of C burned to CO. Determine the quantity of oxygen required, the quantity of air required, the quantity of nitrogen in this air, and the quantity of heat liberated.

2. What will be the volume of the CO formed as above if measured at 62° F. and 14.7 lbs. pressure?

3. Assume 15 lbs. of C burned to CO₂. Determine the quantities of oxygen and air required, the quantity of nitrogen contained in this air, and the quantity of heat liberated.

4. What will be the volume of the CO₂ formed from 15 lbs. of carbon if measured at 62° F. and 14.7 lbs.?

5. What will be the volume of the flue gases formed by the combustion of 11 lbs. of carbon to CO₂ with the theoretical air supply?

6. The quantity of CO obtained by the combustion of 8 lbs. of carbon is burned to CO₂ with the theoretical amount of oxygen. Determine the quantities of oxygen and air required, the amount of nitrogen contained in this air, and the quantity of heat liberated.

7. Assume 5 lbs. of C burned in air to CO₂ with an excess coefficient of 1.5. Determine the quantities of oxygen and air supplied, the heat liberated and the composition of the flue gases.

8. The composition of flue gases resulting from the combustion of carbon in air is found to be 21% of CO₂ and 79% of N by volume. What is the value of the excess coefficient?

9. An analysis of flue gases resulting from the combustion of carbon in air shows 12% of CO₂ by volume and no CO. The gases are not analyzed for O or N. What can you say with regard to the air supply?

10. Three pounds of hydrogen burn with theoretical oxygen supply. Determine the weight of oxygen and air used, the weight of the resultant water and the weight of the flue gas.

11. Determine the heat liberated in the preceding problem if the water vapor is condensed and if it is not condensed.

12. How much hydrogen would have to be burned to obtain 20 lbs. of water?

13. The chemical formula of methane is CH_4 . If one pound of methane is burned with theoretical air supply, what weight of air will be used, and what will be the weight of the flue gases?

14. What would be the percentage composition of the flue gases of the preceding problem on a weight basis?

15. The chemical formula of ethane is C_2H_6 . Determine the calorific value of this material by means of the formula given in the text.

16. A certain material is found to have the following analysis on a weight basis: C, 85%; H, 12%; O, 1%; S, 2%. Determine the calorific value of this material by means of the formula given in the text, assuming that all the oxygen present is in combination with hydrogen.

17. Determine the amount of oxygen required to completely burn 3 lbs. of the material described in the preceding problem.

18. One pound of carbon is burned to CO_2 in pure oxygen in a vessel so arranged as to maintain constant internal pressure. The specific heat of CO_2 at constant pressure and at ordinary temperatures is about 0.21. Calculate the theoretical temperature rise and the temperature of combustion, using this value of the specific heat and assuming an initial temperature of 60°F .

19. Make the same calculations as called for in the preceding problem, but using the value 0.27 for the specific heat of CO_2 . This is more nearly the average value of the specific heat over the range of temperature existing in such a case.

20. The hydrocarbon ethylene is represented by the chemical formula C_2H_4 . Assume that one pound of this material is burned in air within a vessel arranged to maintain the products at constant pressure and that the excess coefficient is 1.5. Determine the theoretical temperature of combustion if the initial temperature is 60°F ., the mean specific heat of CO_2 is 0.27, that of H_2O is 0.61, that of N is 0.27, and that of O is 0.24.

CHAPTER XVI

FUELS

132. Commercial Fuels. In engineering practice anything which is combustible and which can be procured in large quantities *at a reasonable cost* is called a fuel. The principal commercial fuels are:

- a. Solid $\left\{ \begin{array}{l} (1) \text{ Coal.} \\ (2) \text{ Wood and wood wastes.} \\ (3) \text{ Vegetable wastes.} \end{array} \right.$
- b. Liquid $\left\{ \begin{array}{l} (1) \text{ Crude petroleum or natural oil.} \\ (2) \text{ Various products made from petroleum.} \\ (3) \text{ Methyl and ethyl alcohol.} \end{array} \right.$
- c. Gaseous $\left\{ \begin{array}{l} (1) \text{ Natural gas.} \\ (2) \text{ Artificial or manufactured gases.} \end{array} \right.$

Coal is by far *the most extensively used fuel* because of its abundance and relative cheapness in most localities. However, in oil-producing regions the *crude oil* and some of the products made from it are more often the commonly used fuel, particularly if good coal is not mined in the immediate vicinity.

Wood is, in general, too valuable to be used exclusively as a fuel excepting on the frontiers where wooded territory is being opened up and where coal cannot be procured excepting at prohibitively high cost. Wood wastes, on the other hand, are very often used for fuel in the industries producing them.

Vegetable wastes, like wood wastes, are essentially of local value, being practically entirely consumed by the industries producing them.

Natural gas is in many respects an ideal fuel, and is extensively used for power production in some localities. The diminution in the quantity available, the consequent rise in the price, the great economy achieved in burning this gas in gas engines and the increased use of the gas for domestic purposes are, however, gradually eliminating this fuel from the steam-power field.

Artificial gases have never been extensively used for the generation of steam, as it is generally cheaper to burn the materials from which the gases are made, rather than to convert them into gas and then to burn the gas under boilers. This condition may change in the future when better markets have been opened up for some of the by-products which can be obtained from artificial gas plants.

133. Coal. The word coal is used as the name of a great group of natural fuels which consist of more or less *metamorphosed vegetable remains*. At one end of the group is the material known as *peat*, which is only slightly changed from the original vegetable substance; at the other end is the *graphitic anthracite* which has undergone such radical metamorphosis that practically all of the original vegetable material excepting carbon and ash has been eliminated.

A common, rough classification of the coals in the order of age, or of completeness of carbonization is,

1. Peat or turf.
2. Lignite (brown or black).
3. Sub-bituminous coal.
4. Bituminous coal.
5. Semi-bituminous coal.
6. Semi-anthracite.
7. Anthracite.
8. Graphitic anthracite.

The divisions are not at all exact, as they depend partly upon chemical composition and partly upon physical properties.

Another classification of a more exact, variety is that given in Table XI and partly illustrated in Fig. 180, which gives what is known as Mahler's curve. It is for United States coals only. The terms used in this classification are explained in subsequent paragraphs.

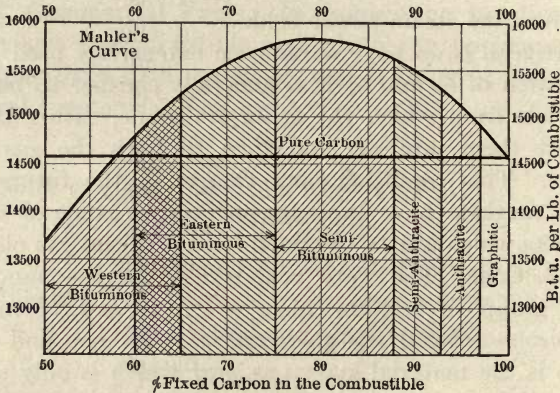

FIG. 180.—Mahler's Curve for United States Coals.

TABLE XI

CLASSIFICATION OF COALS

Division.	Per cent of Fixed Carbon in Combustible.	Per cent of Volatile Matter in Combustible.	Calorific Value, B.t.u. per Pound of Combustible.
Graphitic.....	100 to 97	0 to 3	14,600 to 14,900
Anthracite.....	97 to 92.5	3 to 7.5	14,900 to 15,300
Semi-anthracite....	92.5 to 87.5	7.5 to 12.5	15,300 to 15,600
Semi-bituminous....	87.5 to 75	12.5 to 25	15,600 to 15,900
Eastern bituminous...	75 to 60	25 to 40	15,800 to 14,800
Western bituminous..	65 to 50	35 to 50	15,200 to 13,700
Lignite.....	under 50	over 50	13,700 to 11,000

The *graphitic anthracite* occurs in very small quantities and mostly in Rhode Island. With a few minor exceptions the *anthracites* occur only in Eastern Pennsylvania and the

semi-anthracites are almost entirely confined to the western edge of this field.

The *semi-bituminous* coals are found on parts of the eastern border of what is known as the Appalachian coal field, extending from central Pennsylvania through the intermediate States to the northern part of Alabama. The greater part of this enormous bed consists of *eastern bituminous* coal. *Western bituminous* coals are found in large beds in the central part of the United States, principally in the States of Illinois, Indiana and Kentucky on the east of the Mississippi River, and in Iowa, Kansas and Texas to the west of that river.

Lignite is found in small quantities in nearly all of the western half of the United States and in large beds in the Dakotas, Texas, Arkansas, Louisiana, Mississippi and Alabama.

Peat is distributed in small beds throughout practically all of the United States and is continually forming in many marshes and on low-lying lands.

134. Coal Analyses. Two different coal analyses are in use, the simpler being known as the **proximate analysis** and the more exhaustive being called the **ultimate analysis**. Both are made and reported on a weight basis.

The proximate analysis assumes coal to contain four different and separable things, which are called *fixed carbon*, volatile hydrocarbon or *volatile matter* or volatile, *moisture* and *ash*.

Moisture is determined by maintaining a small quantity of finely ground coal at a temperature of about 220° F. for one hour. The material lost during this time is assumed to be moisture only and is reported as such. Coal from which the moisture has been driven in this way is called **dry coal**.

Volatile matter is determined by heating a sample from which the moisture has been driven, or a fresh sample. The coal is maintained at a red to white heat with exclu-

sion of air until there is no further loss of weight. In the case of a previously dried sample the loss under these conditions is called volatile hydrocarbon. If the sample was not previously dried a separate moisture determination is made on a similar sample and the weight of volatile is found by difference.

Fixed carbon is found by combustion of a sample from which the moisture and volatile have been driven, the loss under these conditions being assumed to be entirely due to the combustion of carbon.

Ash is the name given to the incombustible material left behind after determining the fixed carbon.

The volatile hydrocarbons and the fixed carbon as determined in the proximate analysis are assumed to be the only combustible parts of the coal and their sum is called *the combustible*.

Proximate analyses are reported in three different ways: On *coal as received*, on *dry coal*, and on *combustible*.

Since the water content of a sample of coal received at any plant is largely a matter of the weather conditions during shipment, the best idea of the character of a coal can be obtained by excluding the consideration of its moisture content. It is generally best, therefore, to convert analyses to a dry coal basis, that is, recalculate the percentages of volatile, fixed carbon and ash on the assumption that the analysis was made on the weight of coal which would result from drying the sample that was actually used. Excessive moisture is, however, undesirable for steam-raising purposes, and the amount of moisture should therefore be determined in every case.

Ash is also more or less a matter of accident in that the amount contained is largely determined by the care used in mining and subsequent cleaning of the coal. While it has a very appreciable effect upon the character of the material as a fuel it really has little connection with the combustible part of the fuel. For purposes of classifica-

tion, therefore, the ash should also be eliminated and the analysis given on the basis of combustible.

Sulphur is sometimes reported with a proximate analysis. In making such an analysis the greater part of the sulphur is really driven off with, and regarded as, part of the volatile, so that when the sulphur content is desired it must be determined by a separate analysis.

The *ultimate analysis* attempts to separate the dry combustible into the various elements of which it is composed. The percentages of carbon, hydrogen, oxygen, nitrogen and sulphur are determined as well as the percentage of ash in dry coal. Such analyses show the carbon contents of coal to vary from about 98 per cent in the graphitic anthracite through about 97 per cent in the semi-anthracite, 87 per cent in semi-bituminous, 80 per cent in bituminous and 74 per cent in lignites to as low as 61 per cent in peats. The corresponding figures for hydrogen run from about 1 per cent through a range in the neighborhood of 5 per cent for semi-bituminous to about 6 per cent in the case of peat.

Oxygen varies from about 2 per cent or less in the case of good anthracite to as high as 33 per cent for peat; nitrogen generally forms about 1 per cent of the dry fuel and sulphur from 1 to 3 per cent.

135. Calorific Value of Coals. The calorific value of coals on a basis of combustible has been shown to vary approximately according to a smooth curve, but the local variations are so great that no generally applicable formula for calorific value has yet been proposed. The formula commonly used is based upon the ultimate analysis and is similar to that suggested as approximately applicable in the case of mixtures of combustibles. It is known as **Dulong's formula**, and is

$$\text{B.t.u. per lb.} = 14,600C + \left\{ \begin{array}{c} 62,000 \\ \text{or} \\ 52,000 \end{array} \right\} \left(H - \frac{O}{8} \right) + 4000S, \quad (100)$$

in which the letters refer to the weight of the various elements contained in one pound of dry coal.

When an accurate knowledge of the calorific value of a fuel is desired it should be obtained by means of a **fuel calorimeter**. There are many varieties of this instrument, but practically all operate on the same general principle. A known weight of fuel is completely burned within a vessel and the heat liberated is absorbed by water or similar liquid. From measurements of liquid temperatures the heat absorbed by the liquid can be determined, and this with some additions for losses of various kinds must be the heat liberated by the fuel.

136. Purchase of Coal on Analysis. Until quite recently it was customary to buy coal from the lowest bidder provided the material supplied could be made to give satisfactory results in the plant. Obviously the purchaser knew nothing regarding his purchase, and often bought quantities of ash and moisture at the price of combustible. Now, however, the larger power plants and many of the smaller are buying on the basis of analyses and calorific values as determined in calorimeters.

A certain desirable standard analysis is set and certain variations are allowed from it. Wide variations are penalized by deducting so many cents per ton for each variation of a certain degree, and, finally, outside limits are set for moisture and ash beyond which the fuel need not be accepted. In some cases limits are also set for sulphur.

This is the logical method of purchasing coal in large quantities, and is sure to come into very general use as its advantages become known.

137. Petroleum. This material is obtained from drilled wells and has been found in many widely separated sections of the country. The oil wells of Pennsylvania and neighboring States, of Oklahoma, Texas and California have been the most productive and are hence the most widely known.

Natural petroleum, as it occurs in the United States, is

generally a dark, rather thick, oily liquid with a characteristic odor. It varies widely in composition so far as the compounds contained are concerned, but the variations in ultimate composition, specific gravity and calorific value are comparatively small.

The *ultimate analysis of crude oil* generally shows about 83 to 85 per cent of carbon, 13 to 15 per cent of hydrogen and small quantities of oxygen, nitrogen and sulphur.

The *specific gravity* generally lies between 0.80 and 0.90 and in most cases is nearer the upper figure. It is common practice to express the gravity in terms of the Beaumé scale, an arbitrary scale developed for an instrument known as the Beaumé hydrometer. This device is arranged to float in liquids and measures the gravity by the distance to which it sinks. Various corresponding values of the Beaumé scale and specific gravity are given in Table XII for the region most used in connection with petroleum.

TABLE XII

CORRESPONDING BEAUMÉ READINGS AND SPECIFIC GRAVITIES

Beaumé Reading.	Specific Gravity.	Beaumé Reading.	Specific Gravity.
20	0.9333	34	0.8536
22	0.9210	36	0.8433
24	0.9090	38	0.8333
26	0.8974	40	0.8235
28	0.8860	42	0.8139
30	0.8750	44	0.8045
32	0.8641	46	0.7954

The *higher calorific value* varies between 19,000 and 20,000 B.t.u. per pound and the lower value is generally 1000 to 1500 B.t.u. lower.

Crude oil is sometimes used for fuel, but this is undesirable, for two reasons. First, the crude oil contains many highly volatile constituents which can be distilled

off and which have a high market value in the forms of gasoline and allied distillates. Second, the presence of these highly volatile constituents in the oil makes it more dangerous, as combustible vapors are given off in large quantities at low temperatures and the mixtures formed with the oxygen of the air are often highly explosive.

As a consequence, the material generally sold as fuel oil is a residuum left after distilling off the more volatile constituents of the crude oil. It has practically the same properties as the crude, excepting that dangerous vapors are not given off at so low a temperature.

PROBLEMS

1. A sample of coal gives the following proximate analysis: moisture, 5%; volatile, 4.25%; fixed carbon, 80.75%; and ash, 10%. Determine the percentage of combustible and the percentages of fixed carbon and of volatile in the combustible.

2. What variety of coal is indicated by the values obtained in Prob. 1?

3. The following results were obtained in making a proximate analysis of a sample of coal; moisture, 7%; fixed carbon, 56.7%; volatile, 24.3%; ash, 12%. Determine the percentage of combustible and the percentages of fixed carbon and of volatile in the combustible. What variety of coal is indicated by these values?

4. The ultimate analysis of a sample of dry coal gave the following results: carbon, 79.12%; hydrogen, 4.14%; oxygen, 1.84%; sulphur, 0.92%; nitrogen, 0.74%; ash, 13.24%. Recalculate these values for an ash-free coal.

5. Determine by means of Dulong's formula the upper and lower calorific values of the coal described in Prob. 4.

6. The ultimate analysis of a sample of crude petroleum from which all water was removed gave the following results: carbon, 85%; hydrogen, 13%; sulphur, 1.0%; oxygen, 0.25%; nitrogen, 0.12%; ash (sand and similar material), 0.63%. Determine the upper and lower calorific values by means of Dulong's formula.

CHAPTER XVII

STEAM BOILERS

138. Definitions and Classification. The term boiler is generally applied to the combination of a furnace in which fuel may be burned continuously and a *closed vessel* in which steam is generated from water by the heat liberated within the furnace.

Boilers are classified in many different ways, the more important being given in the following schedule:

CLASSIFICATION OF BOILERS

- | | | |
|--|---|---|
| (1) According to form | { | (a) Plain cylindrical,
(b) Flue,
(c) Tubular,
(d) Sectional, etc. |
| (2) According to location of furnace | { | (a) Externally fired, and
(b) Internally fired. |
| (3) According to use | { | (a) Stationary,
(b) Portable (as on trucks, or rollers),
(c) Locomotive,
(d) Marine. |
| (4) According to direction of principal axis | { | (a) Horizontal,
(b) Inclined,
(c) Vertical. |
| (5) According to relative positions of water and hot gases | { | (a) Water tube,
(b) Fire tube. |

Examples of boilers of the different types mentioned are given in subsequent paragraphs.

139. Functions of Parts. It has been shown that there are two essentially different parts in the apparatus commonly known as a steam boiler, the *furnace* and the *boiling vessel*. A simple form of boiler known as a **horizontal, return tubular boiler**, or an H.R.T. boiler, is shown in Figs. 181 and 182 with the two essential parts and their components

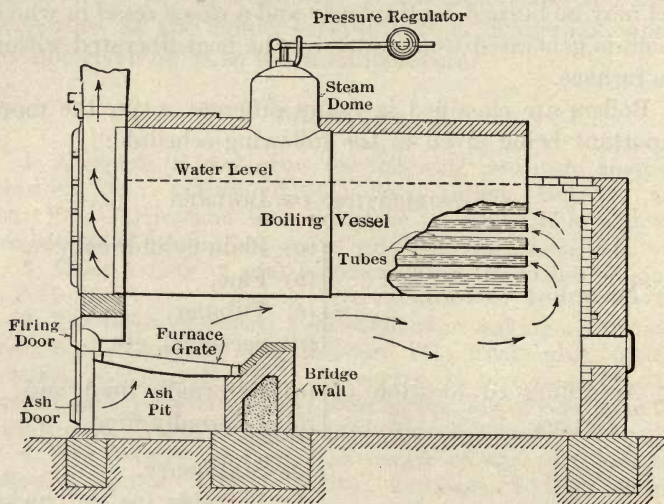

FIG. 181.—Sectional Elevation of H.R.T. Boiler and Furnace.

indicated. The furnace consists essentially of the combination of grates, bridge wall, fire and ash doors, the ash pit and the space above the grates. It is the function of the furnace to so burn the fuel that the maximum amount of heat will be made available for absorption by the water within the boiling vessel.

It is the function of the boiling vessel to transmit to the water within it the greatest possible quantity of the heat thus made available and to resist successfully the

tendency to rupture under the action of the high internal pressure, that is, the pressure of the steam.

In the type of boiler shown the fuel is "fired" by hand, that is, it is spread on the grate by being thrown from a scoop shovel through the opened fire door. Air enters through both doors in regulated proportions and in such quantities as best to approximate complete combustion.

The hot gases resulting from the combustion pass over the bridge wall, along the lower part of the boiler shell and then through the fire tubes, or flues, toward the front of the boiler as shown by arrows in the figure. From the front end of the tubes the products of combustion pass up through the smoke box to "breechings" or "flues," which carry them to the stack.

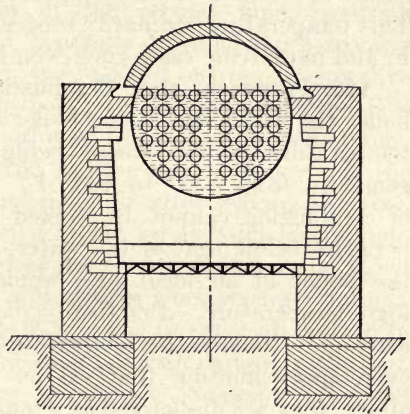

FIG. 182.

Section through Furnace of H.R.T. Boiler.

Heat is received by the water within the vessel in two different ways:

(1) The hot fuel bed on the grate radiates energy in the same way that the sun or any other glowing body radiates energy. Some of this energy traverses the space between fuel bed and boiler shell and ultimately passes through that shell to the water within. The rest of the radiated energy passes into the walls surrounding the furnace and heats them and the surrounding atmosphere.

(2) The hot gases of combustion pass over the heating surface of the boiler, as shown, and transmit part of their

Heat is received by the water within the vessel in two different ways:

heat to the water on the other side of those surfaces. The rest of the heat which they carry is either lost to the surrounding walls or is carried up the stack by the gases which leave the boiler at a comparatively high temperature. This temperature ordinarily ranges from about 500° to 700° F. and in extreme cases goes even higher.

140. Furnaces and Combustion. In most forms of boiler the water within the boiler has practically the same temperature as the steam being generated, and this is generally from 320° to 400° F. Obviously the products of combustion cannot be cooled by the water to a temperature below that of the water, so that the gases leaving the boiler in an ideal case would have a comparatively high temperature. Practically, it is found undesirable to attempt to reduce the temperature of the gases to a value even approximating that of the water and, as indicated above, they are discharged at a temperature several hundred degrees higher. In order that the maximum amount of heat may be made available for the boiling vessel the products of combustion must therefore leave the furnace with the highest possible temperature, and the ideal furnace would completely burn the cheapest fuel available in such a way as to give this highest possible temperature and not to generate smoke.

Real furnaces fall far short of this ideal performance, for numerous reasons. The more important of these are given in the following paragraphs:

(a) *Complete Combustion of Carbon.* In a real furnace the combustion of the carbon of the fuel may be incomplete in two senses; first, some of the carbon may remain entirely unoxidized and pass off with the ash, and second, some of the carbon may be burned to CO instead of to CO_2 .

Imperfect combustion of the first kind can result from fuel falling through the openings in the grate before it has been ignited or when only partly burned, or it can result from failure to get air to some of the carbon in sufficient

quantities to burn it completely before all of the surrounding fuel has been converted into ash and the locality cooled down to such an extent as to allow the unburned carbon in its midst to cool below the temperature of ignition.

Imperfect combustion of the second kind, resulting in the formation of CO, generally results either from a lack of sufficient air above the fuel bed or from an excessive quantity of air above the bed. In any furnace there is a tendency toward the formation of CO within the bed of fuel, and the deeper the bed the greater this tendency. If the CO thus formed meets sufficient air after leaving the fuel, and if the temperatures of CO and air be sufficiently high, it will burn to CO₂. Part of the air for what may be called the *secondary combustion* will always work its way through the fuel bed, because it is impossible to bring all oxygen in the air passing through into contact with carbon of the fuel. The remainder of the air required is generally admitted through the fire door and is heated by passing over the front part of the fuel bed. If too great a quantity of air is admitted in either way its temperature may be so low as to cool the CO below its temperature of ignition and thus fail to accomplish the object sought.

It has been shown that the combustion of pure carbon with the theoretical air supply would give gases containing about 21 per cent by volume of CO₂. If the combustible of real coal be assumed to consist entirely of carbon, the same proportion of CO₂ would result from ideal combustion. Practically, it is so difficult to bring the oxygen of the air into contact with the carbon of the fuel that a large excess is always used, the excess coefficient ranging from about 1.3 to over 2 and averaging about 1.5 to 1.7 under very good conditions. The latter figures correspond to percentages of CO₂ of 14 and 12 respectively, but a value as low as 10, which corresponds roughly to an excess coefficient of about 2, is not at all uncommon and is generally regarded as a very good result except in the largest plants.

(b) *Complete Combustion of Hydrocarbons.* The hydrocarbons which appear as volatile matter in the proximate analysis are practically all distilled from the fuel, as it is heated in the furnace before ignition in the same way as when making a proximate analysis. If they are to be completely burned they must be mixed with the requisite quantity of air after distillation and both the vapors and the air must be maintained at a sufficiently high temperature until combustion is complete. Part of the air for the combustion of distilled volatile filters through the fuel bed and the rest must be admitted through the fire door or in some equivalent manner.

If the flame formed by burning hydrocarbons is allowed to come in contact with cold surfaces, as, for instance, the heating surfaces of the boiler, the gases are cooled below the temperature of ignition and combustion ceases. This results in the deposit of soot (unburned carbon) upon the heating surfaces of the boiler and in the carrying of soot and unburned hydrocarbons up the stack. The soot and some of these hydrocarbons form the unsightly smoke so familiarly associated with some stacks.

Or, if the air supply is at a sufficiently high temperature, but is insufficient in quantity, the hydrocarbons are incompletely burned and smoke results.

The formation of smoke can be conveniently studied by means of the ordinary kerosene lamp. Such a lamp operates by burning hydrocarbons of the same general character as those distilled from solid fuels. The hydrocarbons are drawn up by the wick in the form of liquids, are vaporized by heat near the top of the wick and then combine with oxygen from the atmosphere to give the luminous kerosene flame.

If the flow of kerosene and the air supply are properly adjusted and if the temperature is high enough, the combustion results in the formation of invisible and practically odorless gases. If, however, the air supply be decreased

or be greatly cooled, a very smoky and very odorous combustion ensues. The same result could be obtained by the use of too great a quantity of air, a condition often attained when the supply of kerosene in the bowl of the lamp is almost exhausted.

The effect of a cold surface is easily seen by inserting a cold metallic or porcelain surface into the tip of the flame and then withdrawing it. It will be found covered with soot.

(c) *Advantages and Disadvantages of Excess Air.* It has been shown that excess air is practically necessary in the real furnace in order to insure against a deficiency at any point, and it is thus advantageous in that it makes the combustion more nearly complete than would otherwise be the case. On the other hand, excess air represents just so much excess material to be heated at the expense of heat liberated by combustion and hence decreases the maximum temperature attained. A sufficiently great supply of excess air could so reduce the temperature that even if combustion were complete very little heat would be made available for absorption by the boiling vessel, because the temperature attained by the products of combustion would be too low.

Excess air in large quantities may also result in cooling unburned gases before combustion to such an extent as to make the completion of combustion impossible.

141. Hand Firing. The commonest type of furnace is that shown in Figs. 181 and 182, and the commonest method of hand firing consists in spreading a layer of fuel as evenly as possible over the entire surface of the fuel bed as often as required to replace the fuel burned away. At such intervals as experience shows to be necessary the fire is cleaned, that is, the ashes are worked out from under the fuel by means of slice bars, so that practically nothing but live fuel resting on a thin layer of ash remains behind.

This method is open to many serious objections; the more important are:

1. There is a gradual increase in thickness of fuel bed from the time of one cleaning until the time of the next. This gives a constantly changing set of requirements for the proper proportions of air entering below and above the fuel bed and a constantly changing resistance to flow of air through the bed, so that great skill is necessary if the best conditions are to be maintained throughout.

2. There is always a tendency for a fuel bed to burn faster at some points than at others, due to the accidental distribution of fuel, ash and air. Where "holes" are formed in this way large quantities of comparatively cold air can pass through with the consequences already enumerated. It takes considerable skill and watchfulness on the part of the fireman to prevent the formation and continued existence of such holes.

3. The firing door must be opened wide every time that fuel is to be fired, that is, at intervals varying from two or three minutes to fifteen or more, depending on load, character of fuel, etc. While the door is open large quantities of cold air readily flow into the furnace and cool down all parts of it, and a proportionately smaller amount will ordinarily pass through the fuel bed. The result of this on the flue gases and operation of the boilers has already been considered, but there is another result of equal or greater importance. As a consequence of this action the volatile hydrocarbons distilled off from the freshly fired fuel, which are themselves at a comparatively low temperature, are surrounded on all sides by cooled walls and come in contact with cold air only. The chances of their burning completely are very slight, and a great part of these volatilized materials passes off unburned as invisible gas and as smoke. Obviously the greater the volatile content the greater the difficulty, so that anthracite causes least trouble in this way, while most bituminous coals give heavy black smoke when burned under these conditions.

The cooling down of the interior of the furnace during

firing is accompanied by the covering of the fuel bed with cold fuel, so that, for the time being, very little radiant heat enters the boiling vessel, and the gases which come in contact with its surface are comparatively cool. The maintenance of a constant steam pressure under these conditions is practically impossible, but the difficulties can be partly overcome by very frequent firing of small quantities, so that the door is open a very short time and also that the layer of fuel is very thin and does not cut off much heat.

4. The cleaning of the fire necessitates keeping the fire door open for several minutes, with results of the same variety as those just enumerated.

Summing up these difficulties, they divide themselves into two classes—those which can be almost or entirely eliminated by skill of a very high order and those which are inherent and cannot be eliminated by skill. It will also be observed that all should give more trouble with fuels high in volatile than with those of the anthracite variety, both as to incomplete combustion and to the formation of smoke.

Several other methods of hand firing have been proposed, particularly for use with bituminous coals, and some of them have been successfully utilized in isolated instances. Nearly all depend upon covering only part of the fuel bed at one time and, by alternating the parts covered in this way, fresh fuel on one part of the bed is coked while air is heated by coming in contact with the uncovered incandescent part of the bed and is therefore in proper condition to burn more perfectly the volume of hydrocarbons being distilled off. These methods are all good, but they involve a great deal of careful work and a high degree of skill on the part of the fireman.

Other methods of eliminating some of the difficulties depend upon modifications of the furnace and air supply. Most attempt to entirely surround the fuel and the gases given off with heavy masses of brick work and tile, so that

enough heat will be stored during incandescent periods to tide over the periods of cooling. Some forms have combined with this idea a series of air ducts in the brick work so arranged that air on its way to the furnace passes through these ducts and is heated. In some cases the air supply is automatically controlled and more air is supplied above the fire during the period of distillation, or coking, as it is called, than during the following period, when the coked coal is brightly incandescent and little volatile matter is present.

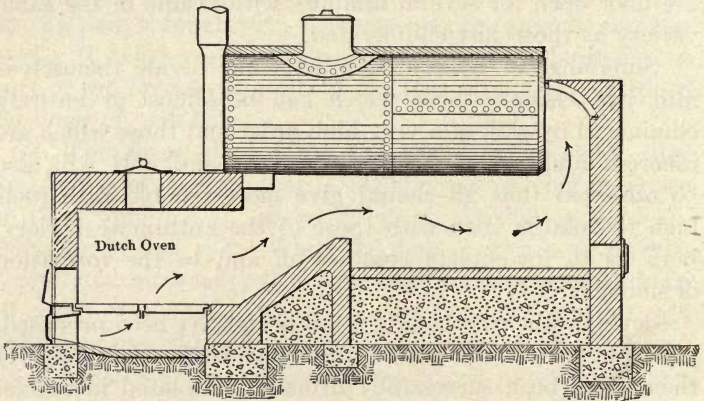

FIG. 183.

In some hand-fired furnaces which are intended for use with bituminous coals that give a long flame the parts of the boiling vessel within range of the flames are covered with tiles. This prevents impingement of unburned gases upon cool surfaces and thus tends to prevent the formation of smoke and incomplete combustion.

Carrying this principle to its logical conclusion results in the installation of the grate in a firebrick chamber in front of the boiler-setting proper, as shown in Fig. 183. Such a device is known as a *Dutch oven* and is often very efficient in totally or partially preventing the formation of

smoke. It does not, however, give as high an economy as might be expected, because a great part of the radiant heat of the fire does not reach the boiler surfaces and because the large external surface results in great radiation losses to atmosphere.

Another interesting modification consists of reversing the direction of the draft, that is, the direction in which the air passes through the fuel bed. The type of furnace already described is known as an **updraft furnace**, because the air passes upward in flowing through the bed. The modified type here referred to is called a **downdraft furnace**, because the air flows downward in passing through the fuel.

In downdraft furnaces the coal is fired on top of the grate as in other types, but the air is admitted above, flows downward toward what would normally be the ashpit, and from there on over the heating surfaces of the boiler. Fresh coal fired on top of the incandescent bed in such a furnace distills as in other types, but the volatiles are mixed with the entering air and are carried downward through the hot bed so that ideal conditions for combustion are more nearly attained. In some forms there is a second updraft grate beneath the downdraft grate. This second grate receives partly burned coals falling through from the upper grate and holds them until combustion is practically completed.

In downdraft furnaces the grate bars are generally made of pipes, and water, from the boiler or on its way to the boiler, is circulated through them. If this were not done the grates would quickly warp out of shape and ultimately burn away because of the high temperatures to which they are subjected.

142. Mechanical Grates. In order to overcome the difficulties arising from opening the doors for the purposes of cleaning the fire, numerous so-called rocking, shaking, self-cleaning, or dumping grates have been developed. These are generally built up of grate bars which have a

rough T or an inverted L section with the upper horizontal branch of the T or inverted L slightly rounded, as shown in Fig. 184. These bars are arranged in groups with their longitudinal axes running across the grate, and they are so supported that they can be rocked about a point in the vertical leg of the T or L by means of levers located at the front of the boiler. By rocking the bars the lower part of the fuel bed which has been burned to ash can be dropped into the ash pit, while the upper part is sufficiently agitated to close up holes which may have formed, and this can all be done

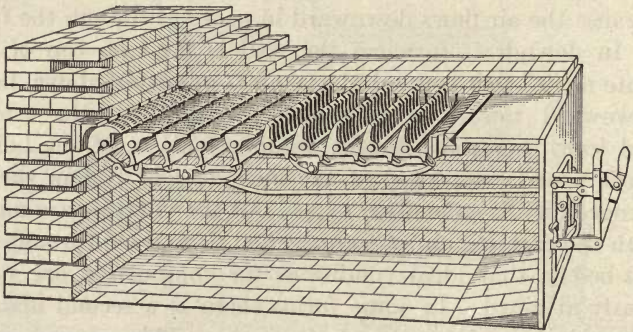

FIG. 184.

with the doors closed. Or, if desired, part or all of the fuel bed can be dropped into the ash pit by a similar rocking motion.

143. Smoke and Its Prevention. An idea of the reasons for the formation of smoke will have been obtained from the preceding paragraphs. A reasonably skillful fireman should have little difficulty in burning anthracite coals in the simpler forms of furnaces without smoke, but it is almost impossible to commercially burn many of the varieties of bituminous coals in this way without the formation of excessive volumes of dense black smoke at intervals immediately following each firing.

Aside from all æsthetic and sanitary considerations, smoke is undesirable because it represents poor furnace conditions and waste. The actual loss of carbon in visible smoke is generally almost negligible in comparison with the other losses in the form of unburned hydrocarbons, the lowered initial temperature, etc. All of these losses combined represent a waste of considerable magnitude.

The proper method of smoke elimination is not the combustion or removal of smoke already formed, but it is the burning of fuels in such ways as not to form any appreciable quantity in the first place. To accomplish this end the following must be achieved:

1. Coal must be fired continuously and uniformly without the opening of doors which admit cold air to the furnace.

2. Volatiles must be distilled continuously and uniformly and in such a place that they are given ample opportunity to mix with proper proportions of air and to burn completely before coming in contact with cool surfaces.

3. The air supply must be properly controlled and tempered to meet the demands of the fuel both in and above the bed.

4. The fire bed must be worked continuously and uniformly so as to eliminate ashes as rapidly as formed and to maintain a bed of uniform depth and condition.

Some of these necessary conditions can be attained by the use of the various forms of hand-fired furnaces already described but, even in the hands of skillful and industrious men, it is impossible to meet all of them. *Mechanical stokers* which more nearly approach the ideals set have therefore been developed and are widely used.

144. Mechanical Stokers. These mechanical devices are useful for two reasons—they eliminate a great deal of labor and they make possible the burning of many varieties of refractory fuels without the formation of excessive quantities of smoke.

Despite the good results which can be achieved by their use, mechanical stokers are not installed in small plants as often as might be expected. This is because good stokers are very expensive in comparison with hand-fired furnaces and, despite economy of fuel, do not generally show a financial saving unless their use eliminates the services of several firemen.

It is generally assumed that one man can care for water, coal and ashes for about 200 boiler horse-power or can handle coal only for about 500 boiler horse-power. Experience has shown that one man can care for about 2000 to 5000 boiler horse-power when the boilers are equipped with good stokers and coal-handling apparatus.

Financial calculations will generally show stokers to be profitable investments for plants of 2000 or more boiler horse-power. Where they are installed in smaller plants, the absolute necessity of eliminating smoke or the use of very poor varieties of coal have generally dictated their use.

Mechanical stokers can be roughly divided into two types, those which duplicate hand spreading of fuel and are known as **sprinkler stokers**, and those which supply fuel at one or more points and work it progressively toward the ash end of the apparatus as it burns. The first type has not been widely installed, though it is possible that it may meet with more popular approval after further development.

Stokers of the second type may be roughly divided into five classes, which are

1. Chain grates.
2. Inclined stokers.
3. Underfeed stokers.
4. Combinations of above.
5. Powdered coal stokers.

A **chain grate**, as made by the Illinois Stoker Company, is illustrated in Figs. 185, 186, 187, and 188. It consists

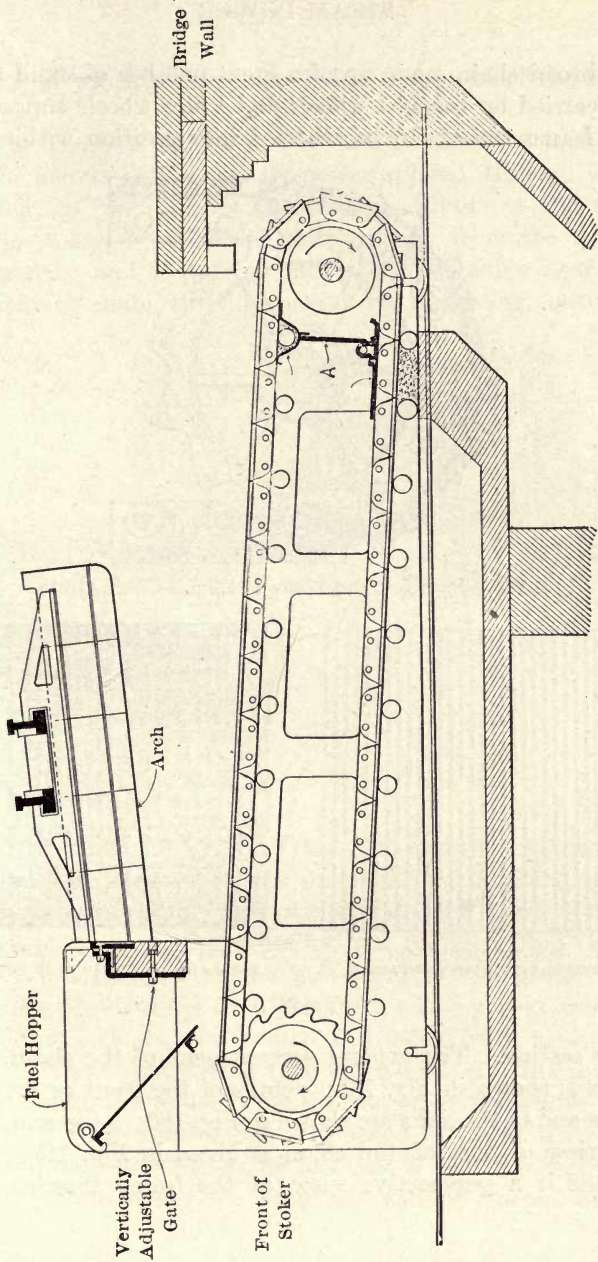

FIG. 185.—Illinois Chain Gate Stoker.

of a broad chain made up of a great number of small links and carried on toothed wheels and roller wheels supported in a frame which can be wheeled into position within the

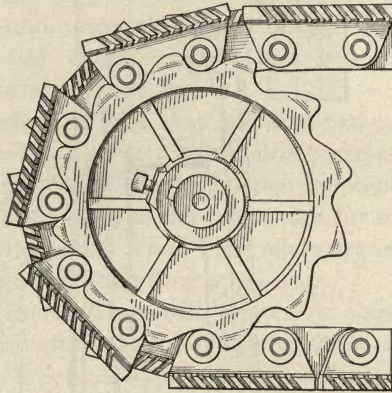
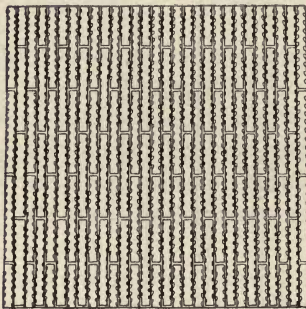

FIG. 186.—Sprocket and Links of Illinois Chain Grate.



TOP VIEW OF CHAIN
SHOWING DISTRIBUTION OF AIR SPACES



BOTTOM VIEW OF CHAIN
SHOWING ROLLERS FOR DRIVING-SPROCKET
ENGAGEMENT

FIG. 187.

boiler setting. The general arrangement of the chain and rollers is shown in Fig. 185; details of the front or driving rollers and of the links are shown in Fig. 186; a top and bottom view of part of the chain is given in Fig. 187; and Fig. 188 is a perspective view of the frame showing the

tracks on which it may be rolled into and out of the boiler setting.

The chain is driven slowly in the direction indicated by the arrows in Fig. 185 by power applied, through worm gearing, to the shaft of the toothed wheels at the front of the stoker. Coal feeds automatically from the hopper by gravity and is carried into the combustion space by the moving chain, the thickness of the bed being controlled

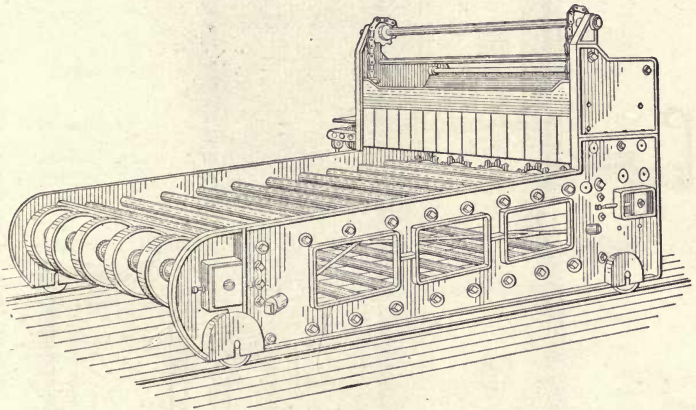

FIG. 188.—Framework of Illinois Chain Grate.

by the height of the adjustable gate shown. As the fuel enters the furnace it passes under the coking arch, which spans the entire front part of the grate and which is maintained at a high temperature by heat radiated from the incandescent fuel nearer the inner end of the grate. The volatiles are distilled from the fresh coal by heat received from this arch and are heated and mixed with air at this point. The coked fuel is then carried on into the furnace and burned, the refuse being discharged at the bridge wall.

If the thickness of bed and speed of chain travel are properly adjusted, all of the fuel can be coked before passing out from under the arch and can be burned almost

completely before reaching the bridge wall, so that practically ashes only will be discharged.

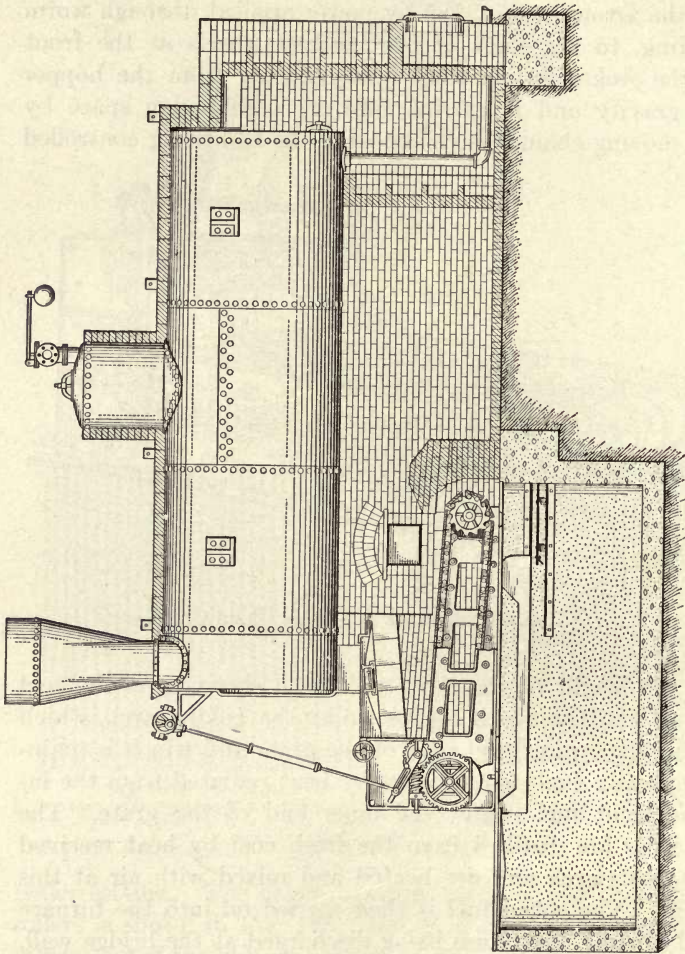

Fig. 189.—H.R.T. Boiler Fitted with Chain Grate.

The apron shown at *A* in Fig. 185 is used to prevent the free passage of air to the part of the chain carrying

practically nothing but ash, as this would result in excessive dilution of the products of combustion.

A stoker of this type installed under a horizontal return-tubular boiler is shown in Fig. 189. In the illustration part of the side frame of the stoker is broken away in order to show the chain and its roller guides. The eccentric shown

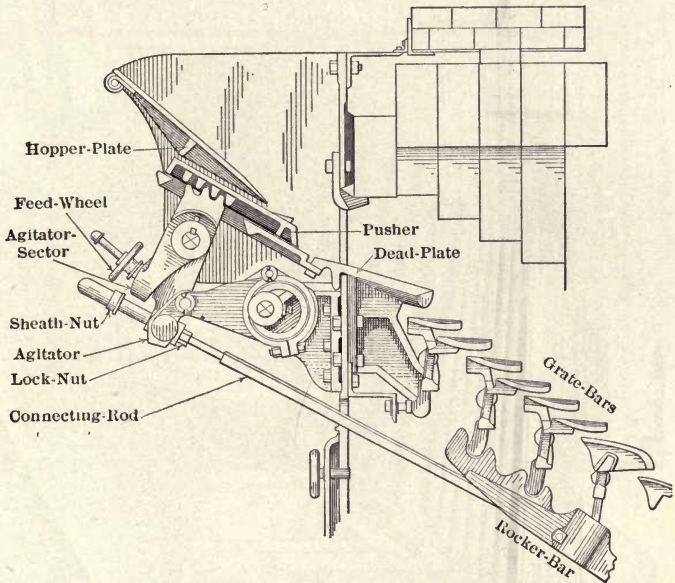

FIG. 190.—Details of Feed Mechanism, Roney Stoker.

near the top of the front of the boiler drives the chain through an arm of adjustable length, which makes possible the control of the speed of chain travel.

An inclined stoker with front feed and a step grate, known as the Roney stoker, is shown in Figs. 190 and 191. The fuel is fed out of the hopper and onto the dead plate by means of the reciprocating pusher. From the dead plate it is pushed down upon the grate bars by the following fuel. These bars are rocked mechanically so that their

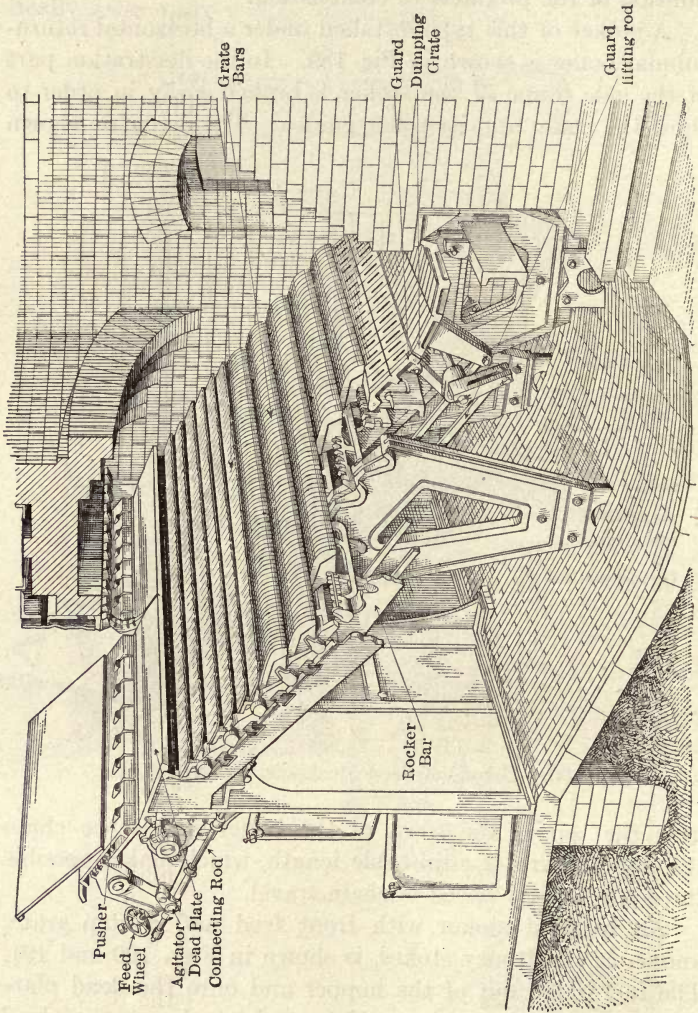

FIG. 191.—Roney Mechanical Stoker.

tops alternately assume horizontal and inclined positions, and this action feeds the fuel downward until it is discharged onto the dumping grate. The material collecting on this grate is periodically dropped by hand into the ashpit.

The fuel is coked while passing under the coking arch

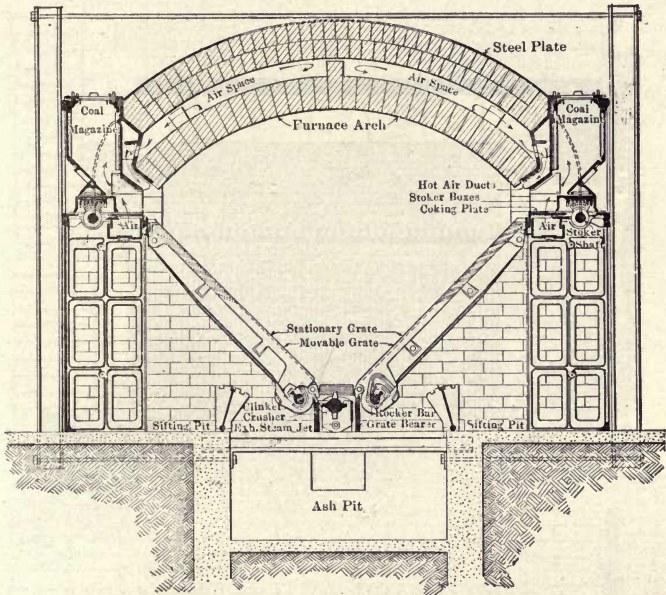

FIG. 192.—Transverse Section of the Murphy Stoker.

and the coked material is practically completely burned by the time it has traveled down the grate. The volatiles are mixed under the coking arch with heated air which has passed through the grate and with heated air forced in above the fuel by steam jets.

An inclined stoker of the side-feed type with bar grates, known as the Murphy stoker, is illustrated in Figs. 192, 193 and 194. This stoker is provided with two coal-

magazines or hoppers which are placed horizontally in the side walls of the boiler setting and feed fuel onto the inclined grate bars, Fig. 192, which carry it downward toward the lower point of the V formed by the grates. The grate bars, Fig. 194, are alternately fixed and movable, the movable bars being hung from above and their

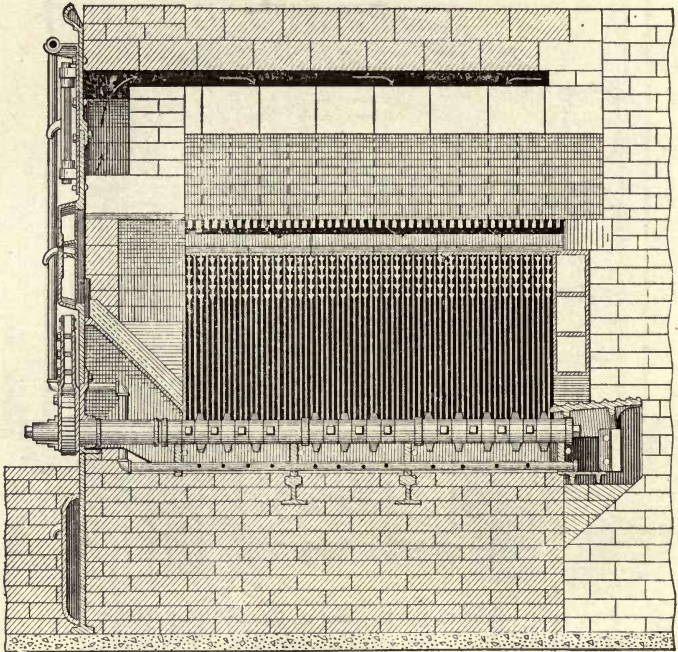

FIG. 193.—Longitudinal Section, Murphy Stoker.

lower ends being moved up and down by power furnished by a small steam engine.

A toothed bar arranged for rotation by hand or by power is located at the bottom of the V and is used for grinding up ash and clinker which is too large to fall through into the ash pit. This bar is kept cool by making it hollow

and connecting one end to the smoke flues or stack so that air is constantly drawn through it.

The location of the coking arch and the method used for supplying warm air should be evident from the figures.

A stoker of this variety is shown in place under a horizontal water-tube boiler in Fig. 195.

An underfeed stoker made by the American Stoker Com-

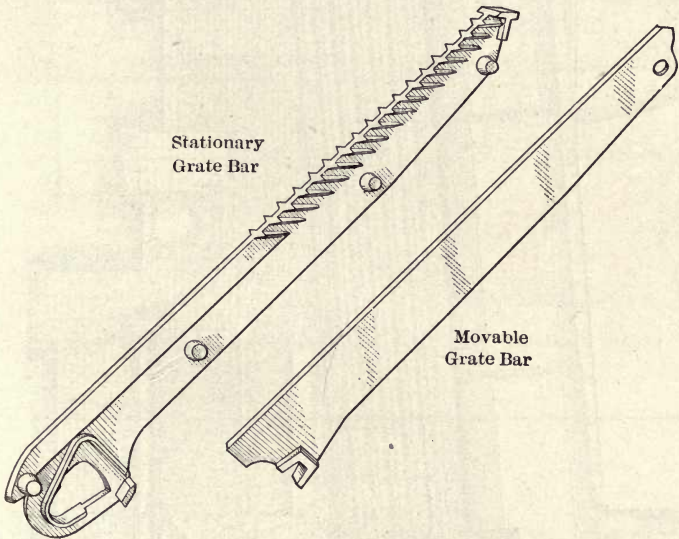

FIG. 194.—Grate Bars of Murphy Stoker.

pany is shown in Figs. 196 and 197. Coal is fed from the hopper onto the reciprocating bottom *B* by means of the reciprocating pusher *P*. The latter forms the bottom of a trough as shown in Fig. 197, and its reciprocating motion feeds the coal upward and out of this trough so that it spills over onto the inclined grate bars. The reciprocating motions are all obtained from the direct-acting steam cylinder shown.

The inclined grate bars are alternately fixed and mov-

able, the movable bars sliding back and forth at right angles to the trough under the action of horizontal rocking

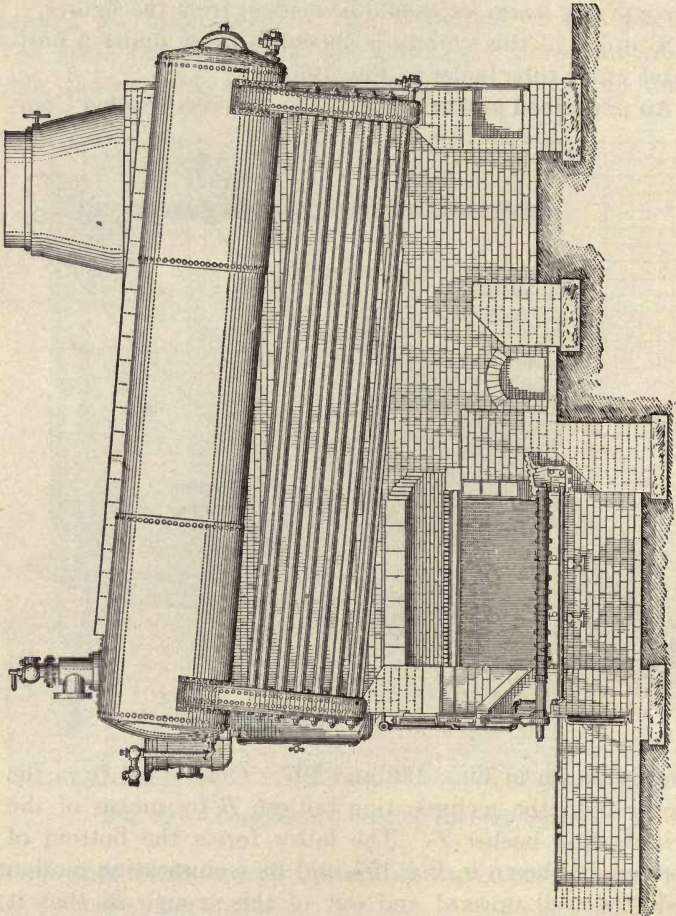

FIG. 195.—Murphy Furnace Arrangement as Applied to Horizontal Water-tube Boiler.

bars *R*. This action gradually feeds the fuel downward and toward the side of the furnace, the refuse finally landing on the dumping trays shown.

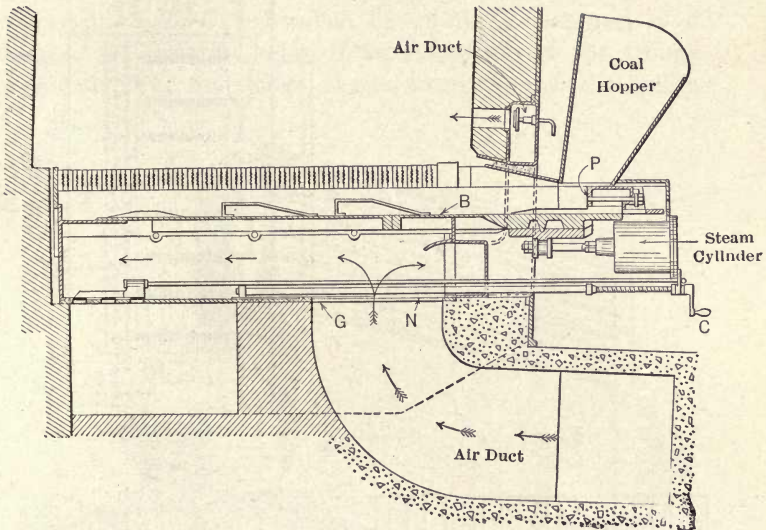

FIG. 196.—Longitudinal Section of Class E American Stoker.

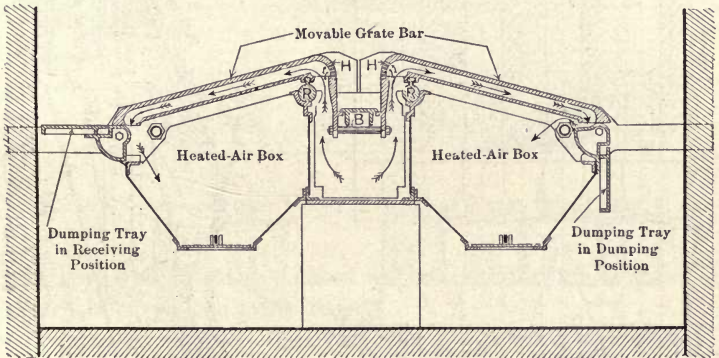

FIG. 197.—Cross Section of Class E, American Stoker.

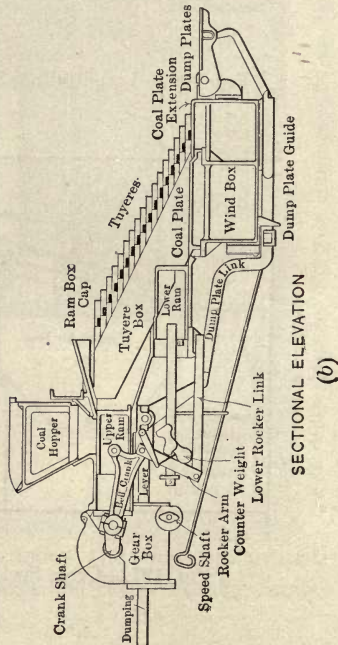
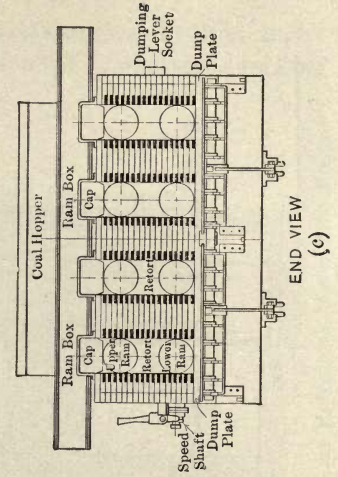
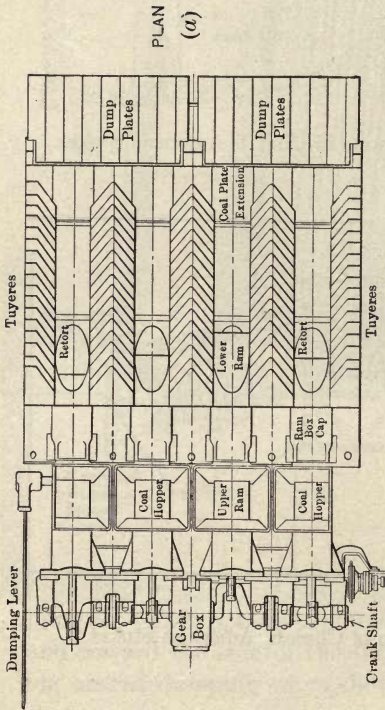

FIG. 198.—Taylor Stoker.

Air enters the duct below the trough through the adjustable gate *G*, controlled by crank *C*, and part of it passes out through holes *H* near the top of the trough Fig. 197. The remainder passes down through the hollow

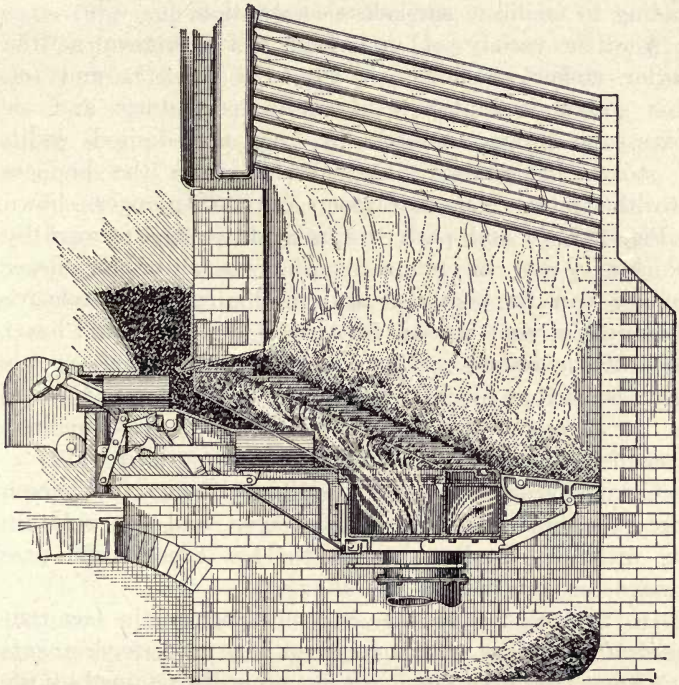

FIG. 199.—Taylor Stoker Under Horizontal Water-tube Boiler.

grate bars and into the heated air box from which it flows upward between the grate bars.

It will be observed that the coal is fed onto the grate from below, so that all volatiles distilled off must pass upward through the incandescent fuel before entering the space above the fuel bed. Part of the air which is to burn

this volatile matter also passes through the fuel bed and the remainder flows over the incandescent fuel from the opening shown near the hopper in Fig. 196. The air and volatiles are thus raised to a high temperature and well mixed, and the operation is continuous and uniform, all tending to facilitate smokeless combustion.

Another variety of underfeed stoker known as the Taylor stoker is shown in Fig. 198 (a), (b) and (c). This stoker is built up of alternated retorts and air boxes, the proper number to give the desired width of stoker being used. Coal is fed from the hoppers into the retorts by the upper ram or plunger shown in Fig. 198 (b) and part of it is again pushed forward by the lower ram or plunger. The stroke of the lower plunger can be regulated and in this way the relative quantities of coal pushed forward in the upper and lower parts of the retorts can be controlled. The coal spreads over the tuyere blocks which form the inclined tops of the air boxes and forms a comparatively even, inclined layer of fuel.

Coking proceeds under the incandescent fuel which forms the upper surface of this layer, and the volatiles mix with air entering through the hot tuyeres and pass upward through the hot fuel above.

In this stoker advantage is often taken of the fact that the draft (pressure of air) required with underfeed stokers is so great that it can be more economically attained by the use of a fan than by the use of a stack. The fan and the coal-feeding plungers are both connected to one engine and the speed of this engine is automatically controlled by the steam pressure within the boiler. As this pressure decreases the engine speeds up, thus delivering more coal and air and as the pressure increases the engine slows down with opposite results. By properly fixing the travel of the plungers initially, the best relative proportions of air and coal are set for the entire range of loads to be carried and the

variation of both is thereafter in approximately the same proportions.

A stoker of this type in position under a horizontal water-tube boiler is shown in Fig. 199. A double-ended arrangement of Taylor stokers as used under very large water-tube boilers is shown in Fig. 200.

Powdered-coal stokers have been invented in great number and are successfully used in several of the industries. They have not, however, been extensively used under steam boilers, although isolated installations have been reported as giving satisfactory results.

In all cases, bituminous coal is crushed to a fine powder and injected into the furnace with the necessary air for combustion, the air under pressure generally being made to mechanically entrain the coal dust and carry it into the furnace. The mixture of fine coal and air gives an intensely hot blow-pipe type of flame, and firebrick and tile are generally used to prevent it from impinging directly upon metallic parts.

Oil firing is essentially a mechanical, rather than a manual process, and while oil burners are not ordinarily understood as belonging to the class of mechanical stokers, they have all the essential characteristics of such apparatus.

To burn oil successfully under a boiler it must be finely atomized and mixed with the necessary quantity of air, and there must be sufficient open space within the furnace for the free development of the flame and the completion of combustion before impingement on cool surfaces.

Oil-burning furnaces are generally given a rather large volume; considerable firebrick is used in such ways as to give incandescent walls and baffles to assist ignition and combustion, and all heating surfaces are arranged so that they are not in the direct path of the flame.

The atomization of the oil is effected in two distinctly different ways. In some forms of burners it is brought about by mechanical means, the oil being pumped through

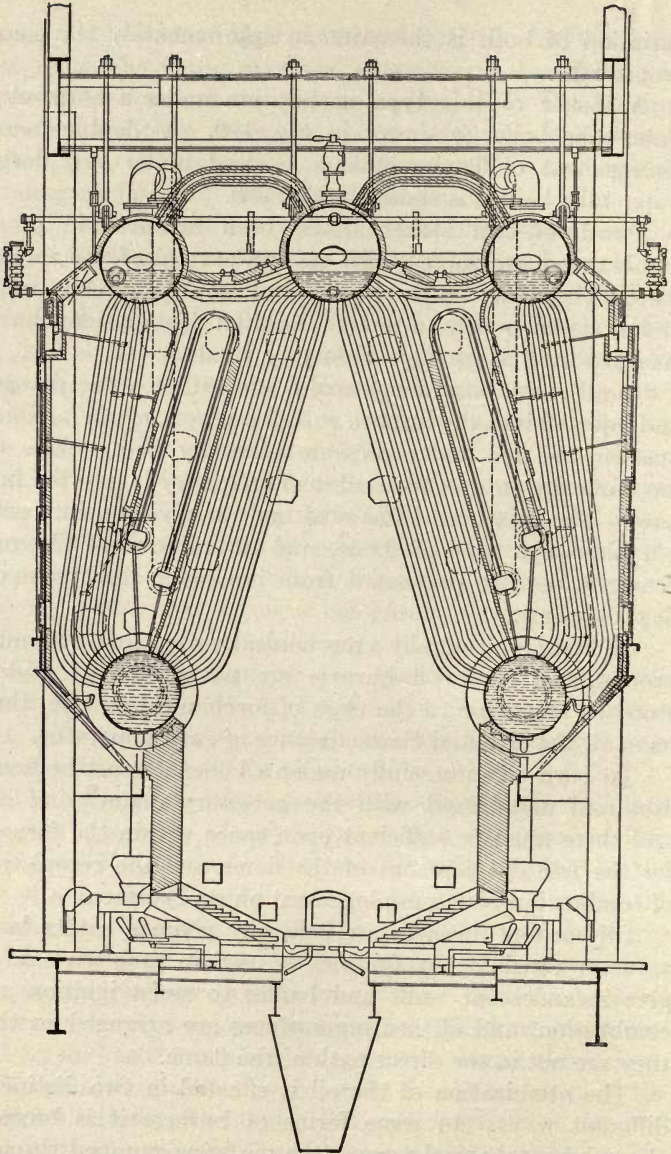

FIG. 200.—Double-ended Arrangement of Taylor Stoker under Sterling Type W. Boiler.

a nozzle of some sort which is so shaped that the issuing jet breaks up into a great number of very small particles. In other forms, steam is used to break up the jet, the steam and oil entering the body of the burner separately and later coming into contact in such a way that the oil is literally torn apart by the steam. This form of burner has been more extensively used in the United States than has the former.

Oil burning shares with the burning of powdered coal, the property of permitting very accurate regulation of the air supply to suit the quantity of fuel being burned. The excess coefficient may therefore be maintained at a low value and the initial temperature may be made correspondingly high. Part of the advantage thus gained over the commoner methods of coal firing is, however, counterbalanced by the quantity of steam used for heating and pumping the oil and for atomizing in some forms of burners.

Both oil burning and powdered-coal burning can be easily made to give smokeless combustion in properly designed furnaces and both yield readily to forcing. That is, the temporary consumption of excessive quantities of fuel to tide over short demands for excessive amounts of steam is comparatively easily effected.

145. Rate of Combustion. The rate at which coal is burned in a given furnace or on a certain grate is generally given in terms of *pounds of coal fired per square foot of grate surface per hour* and is referred to as the rate of combustion.

The rate at which coal can be consumed is largely dependent on the intensity of draft available, that is, on the air pressure available for driving air through and over the bed of fuel. The higher the pressure available, the greater will be the quantity of air which can be supplied and the greater will be the quantity of coal that can be burned. If it were not for the cost of creating the draft, the only limit to increasing the rate of combustion would occur when the velocity of the air became so great that the

fuel would be picked up from the grate and carried onward into the flues in a partly burned condition. Commercial drafts give pressure differences above and below the fuel bed which range from about 0.1 inch of water to as high as 8 ins. In stationary plants the pressures generally range from 0.1 to about 0.5 in cases where hand firing is employed, and are carried as high as 5 or more inches of water with some forms of mechanical stokers.

The best rate of combustion varies with the type and size of fuel, the type and size of furnace, the type and size of boiler, the draft and many other considerations. In ordinary power-plant practice the rates of combustion commercially used generally fall within the following limits: with anthracite, 15 to 20 lbs. per square foot per hour; with semi-bituminous, 18 to 22 lbs.; and with bituminous, 24 to 32 lbs. There is a rapidly growing tendency to exceed these values, particularly in the case of large plants.

As practically all of the volatile is consumed above the grate, the fixed carbon content is practically the determining factor, since it is this constituent that is burned on the grate. This explains the high rate possible with fuels with high volatile content. The most economical results are generally obtained when from 12 to 16 lbs. of fixed carbon are consumed per square foot of grate per hour.

The figures given above do not represent limiting conditions. In torpedo-boat practice, where high-draft pressures are used (from 4 to 8 ins. of water), rates of from 50 to 120 lbs. are attained. On locomotives, which also use high-draft pressures, rates of combustion greatly in excess of stationary practice are generally used.

The capacity of a given boiler, that is, its ability to generate steam, increases as the rate of combustion is increased, since more heat is thus made available. The economy of the combination, that is, pounds of steam generated per pound of coal fired, increases until some best rate of combustion for the fuel in question is reached, and

thereafter decreases. The variation of economy is, however, not very great for a comparatively wide range of combustion on either side of the best rate.

Curves giving approximate draft pressures required for different rates of combustion when different kinds and sizes of fuel are hand fired are given in Fig. 201. The sizes referred to are explained in Tables XIII and XIV. Table XIII also shows the relative increase of ash content as the

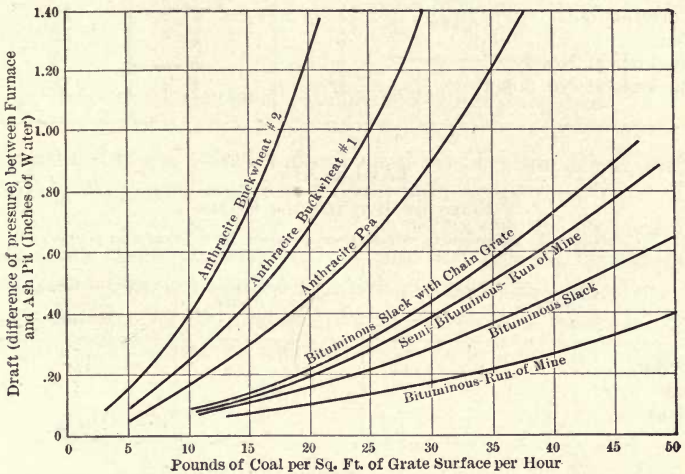

FIG. 201.—Draft Required for Different Rates of Combustion with Different Sizes and Kinds of Fuel.

size decreases, there being a tendency toward the concentration of the ash in the smaller sizes.

146. Strength and Safety of Boiler. Attention has already been called to the fact that the boiling vessel has to be designed with two different requirements in view: it must be mechanically strong to resist internal pressure and it must transmit the maximum amount of heat to the contained water.

Spherical and cylindrical surfaces with the pressure act-

TABLE XIII
SIZES OF ANTHRACITE COAL

(Sizes larger than pea coal generally too costly for power-plant use.)

Name.	Through Screen with Mesh. (Inclusive.)	Over Screen with Mesh. (Inclusive.)	Ash Content (Average).
Run of mine.....	unscreened	unscreened	
Broken.....		$2\frac{3}{4}$	
Egg.....	$2\frac{3}{4}$	2	6
Stove.....	2	$1\frac{1}{4}$	10
Chestnut.....	$1\frac{1}{4}$	$\frac{3}{4}$	13
Pea.....	$\frac{3}{4}$	$\frac{1}{2}$	15
Buckwheat No. 1.....	$\frac{1}{2}$	$\frac{1}{4}$	17
Buckwheat No. 2 or rice...	$\frac{1}{4}$	$\frac{1}{8}$	18

TABLE XIV
SIZES OF BITUMINOUS COALS

(Considerable variation in commercial practice in naming and sizing.)

Name.	Through Bars Spaced Apart. (Inches.)	Over Bars Spaced Apart. (Inches.)
Lump.....		$1\frac{1}{4}$
Nut.....	$1\frac{1}{4}$	$\frac{3}{4}$
Slack.....	$\frac{3}{4}$	

ing on the inside of the curve are best adapted to resist such pressures, as they already have the shape which the pressure would tend to give them. Boilers are, therefore, constructed as far as possible of vessels having only spherical and cylindrical surfaces.

Flat surfaces which are poorly adapted to resist such pressures as act within a boiler must often be used despite their weakness. When incorporated in a boiler they are invariably "stayed," that is, braced by being fastened to other surfaces by stay bolts and other forms of fastenings. Examples will be given later.

Most of the early designs of boilers and many of the

modern types consist of large cylindrical vessels made by riveting together properly shaped steel plates. These shells are often traversed from end to end by flues or tubes for carrying hot gases and generally have flat ends more or less perfectly braced by these tubes and by long tie rods

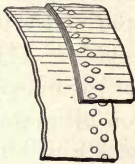

FIG. 202.—Lap Joint.

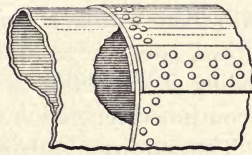

FIG. 203.—Butt Strap Joint.

and other braces. Such boilers when in operation are almost entirely filled with water and often hold many tons.

Boilers of these types have been responsible for many disastrous boiler explosions, and this fact has led inventors to the development of models which should be less dangerous. It seems practically impossible to develop a commercial boiler which cannot be made to explode to a certain extent

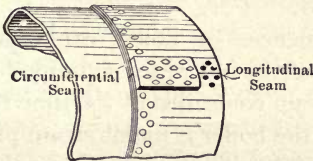

FIG. 204.—Riveted Plates of Boiler Shell.

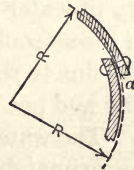

FIG. 205.

if sufficiently mistreated and mishandled; but much can be done to minimize the danger.

The great weakness of the older forms lies in the riveted joints, which can never be made as strong as the plates which they fasten together. Two types of joint are in use; they are known respectively as the **lap joint** and the **butt strap joint**. These are shown in Figs. 202, 203 and 204.

So far as a circumferential seam, that is, one running around the cylinder as shown in Fig. 204, is concerned, the lap joint is perfectly satisfactory and is universally used. With longitudinal seams, however, this is not the case. A lap joint throws the joined edges out of a true cylindrical surface as shown in Fig. 205, and when the vessel is subjected to pressure there will be a tendency for the plates to assume a cylindrical contour as nearly as possible. This causes local bending of the plates on each side of the lines of rivets, and the continued repetition of this action ultimately causes failure. The conditions are often made still worse by calking the joint on a line indicated by a in Fig. 205, that is, by hammering the metal at the inner surface of the edge of the outer plate into firmer contact with the outer surface of the inner plate for the purpose of making a tight joint.

The butt-strap joint can obviously be made so that the joined plates more nearly form a true cylindrical surface.

Other weaknesses of the older forms lie in the flat surfaces used; in constructions which render it possible for sediment to collect on heated surfaces and thus permit local overheating of the plate; and, above all, in the very large quantity of water contained.

The disastrous consequences of boiler explosions are generally due to the action of the hot water contained within the boiler and not to the steam contained at the time rupture occurs. The water within the boiler is under steam pressure and approximately at steam temperature. Removal of the pressure by rupture of the container would enable a great part of this water to flash suddenly into steam at the expense of its own heat, and this is exactly what occurs in the case of a boiler explosion. Local failure causes a sudden lowering of pressure, and this results in the formation of large volumes of steam which, blowing out through the initial fracture, tend to enlarge it, to move the boiler and surroundings, and, in general, to do all possible to further the rupture and make conditions worse.

From the preceding discussion the requirements for maximum safety can be deduced. They are:

1. The smallest convenient diameter of cylindrical vessels, so as to decrease the total load on joints for any given steam pressure.

2. The elimination of the greatest possible number of riveted joints and the use of butt-strap longitudinal joints on all large-diameter, cylindrical vessels.

3. The substitution of curved surfaces for all flat stayed surfaces.

4. So shaping the boiler that the required extent of heating surface may be obtained without enclosing a great volume to be filled with hot water when the boiler is steaming.

5. So shaping the boiler that such water as is contained therein will be divided up into small masses contained within separate vessels connected in such a way that rapid flow of all water toward one point of failure is impossible.

6. So shaping the boiler that no riveted joints shall be in the paths of flames and that no sediment can collect on metal immediately over flames or exposed to very hot gases.

7. So shaping the boiler that it shall be free to expand and contract with changes of temperature, with the least resultant strain on the different parts.

These various requirements are most nearly met in the different forms of water-tube boilers, some of which will be described in succeeding paragraphs.

147. Circulation in Boilers. If a flask of water, such as that shown in Fig. 206, be heated in the manner indicated, the water will gradually acquire motion and follow paths such as those shown by the arrows in the illustration. The heated water will rise in the center of the mass and the cooler water will flow downward around the outer surface.



FIG. 206.—Circulation in a Flask.

Such motion is called **circulation**. Rapid circulation within a boiler is very desirable, since it brings the maximum quantity of water in contact with the heating surfaces in a given time and hence tends to increase the amount of heat taken from those surfaces. It also tends to sweep along any bubbles of steam or gas formed on such surfaces and to carry away any sediment which may have collected, thus preventing overheating of the surfaces.

Circulation can be expedited by providing free and unrestricted paths for the water so as to guide it in the proper directions and by applying the most intense heat at the proper point along the path of the water. The temperature of the water which is subjected to the most intense

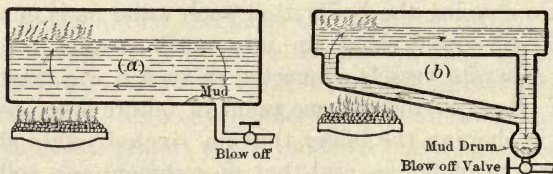

FIG. 207.—Elementary Types of Boilers.

heat is naturally raised and the water at that point becomes less dense than in other parts of the boiler. The formation of steam at such points also materially lessens the density. As a result of this lowering of density the heated water rises and the cooler water descends to take its place. The more rapid this exchange can be made, the more steam can be generated from a given amount of surface in a given time and hence, other things equal, the better the boiler.

The elements of two common forms of boiler are shown in Fig. 207, the arrows indicating the direction of the circulation and its effect upon the delivery of steam and of sediment.

148. Types of Boilers. In a book of this scope it would be impossible to describe all the types of boilers at present

in use. The more important varieties have therefore been chosen for description and illustration.

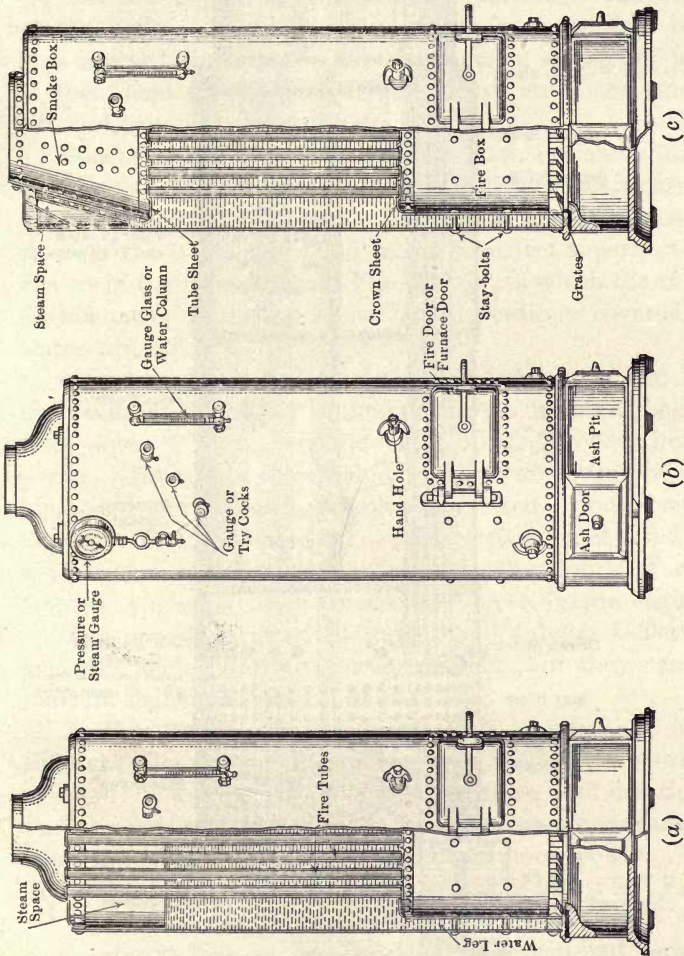

Fig. 208.—Upright or Vertical Fire-tube Boilers.

Two types of **internally fired, tubular boilers** more accurately described as **internally fired, upright or vertical, fire-tube boilers** are shown in Fig. 208. The furnace is

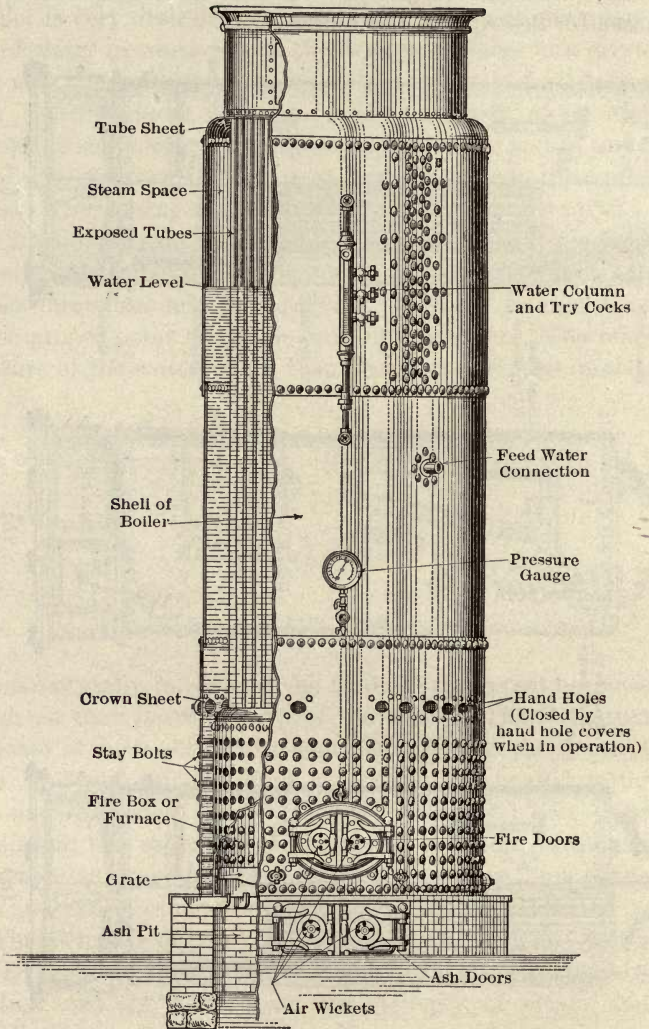

FIG. 209.—Large Internally Fired Tubular Boiler.

contained within the shell of the boiler and is almost completely surrounded with water. The heat radiated from the hot fuel is thus almost entirely received by the water of the boiler. The hot gases, rising from the fuel bed, pass upward through the tubes and, after giving up part of their heat to the surrounding metal, enter the smoke box and pass directly to the stack.

Boilers of the type shown in Fig. 208, (a) and (b) are called *exposed-tube* boilers, because the water level is carried below the tops of the tubes. The tubes, therefore, extend through the steam space and act as imperfect superheaters. Boilers of the type shown in Fig. 208, (c), in which the tubes do not enter the steam space, but are entirely covered by water, are called *submerged-tube* boilers.

Upright tubular boilers of the types shown in Fig. 208 are built by a number of manufacturers in sizes ranging from about 4 boiler horse-power to about 50 boiler horse-power. They are self contained, require no setting of any kind, and are shipped completely erected. Such boilers are very often mounted on trucks or skids and used to generate steam for small hoisting and other forms of contractors' engines. They are also used on steam fire engines.

The pressure carried in these small tubular boilers is generally under 100 lbs. per square inch, but they can be built for higher pressures if desired.

In Fig. 209 is shown a larger type of internally fired tubular boiler as made by the Bigelow Company for stationary use. These boilers are similar to those just described, but are made only in large sizes, in this case, in sizes ranging from 40 boiler horse-power to 200 boiler horse-power. The exposed tubes generally give a superheat of about 25° F.

These large upright boilers can be built to operate with a pressure as high as 200 lbs. per square inch and because of the small area covered by even the largest sizes, they are particularly adapted to locations in which floor space is limited.

The **locomotive type** of boiler is shown in Fig. 210. It is an internally fired, horizontal, tubular or fire-tube, boiler.

Such boilers are seldom used for stationary purposes, but are universally used on steam locomotives and, in the smaller sizes, are often mounted on trucks or skids and used for semi-stationary purposes by contractors and others. Boilers of this type are built in sizes ranging from 10 boiler horse-power or less up to over 100 boiler horse-power for general power purposes, while those used on the largest locomotives generate over 2000 boiler horse-power.

The **Continental type** of boiler, named from the Continental Iron Works, is shown in Fig. 211. These boilers

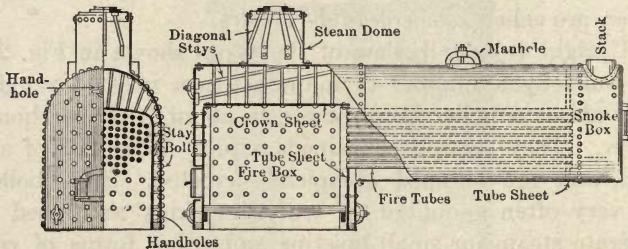

FIG. 210.—Locomotive Type of Boiler.

may be described as internally fired, return tubular, with semi-external combustion chamber, this chamber being outside of the boiler shell proper but being built as an integral part of the boiler and transportable therewith. Boilers of this type are built in sizes ranging from about 75 boiler horse-power to 300 or more.

The grates, furnace and ash spaces, and bridge wall are all carried within circular, corrugated flues, one flue being used in the smaller sizes and two in the larger. The corrugations serve the double purpose of strengthening the flue and of exposing added heating surface to fire and hot gases.

The steam pipe shown just below the steam connection at the top of the boiler is commonly used on boilers for the

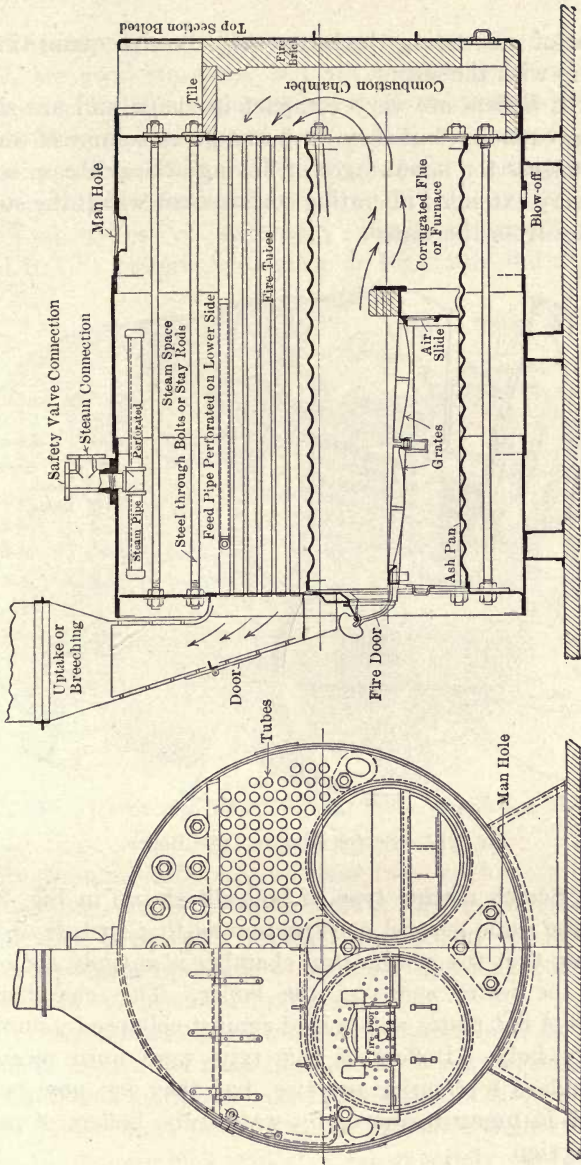

Fig. 211.—Continental Type Boiler.

purpose of preventing the escape of excessive quantities of moisture with the steam.

These boilers are very compact in shape and are short for their capacity, but they contain a great volume of water. They possess the advantages of having a large steam space and a very extended liberating surface over which the steam separates from the water.

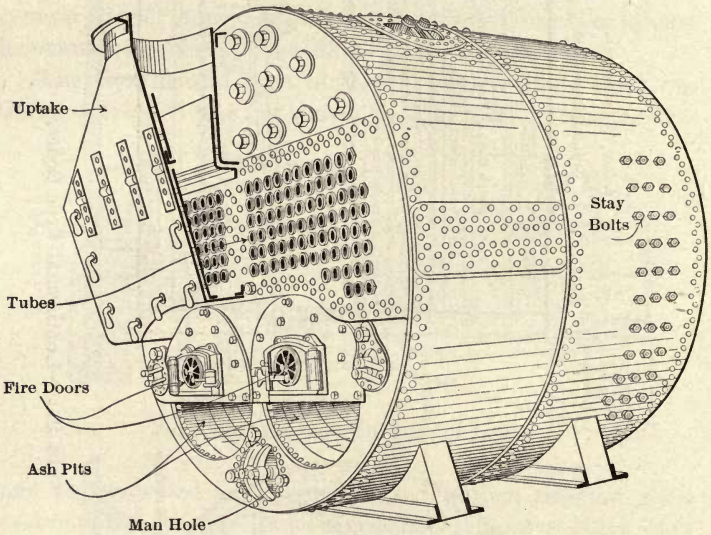

FIG. 212.—Scotch Marine Type Boiler.

The **Scotch marine type** of boiler is shown in Fig. 212. It has the same general construction as that just described excepting that the combustion chamber is entirely enclosed within the water space of the boiler. This chamber is built up of flat plates and is held against collapse by numerous stay bolts. Boilers of this type were until recently the standard for marine practice, but they are now being replaced in many instances by water-tube boilers of more recent design.

Scoten marine boilers are very economical in the use of fuel, are good steamers, and are absolutely self contained. They are built in numerous sizes, the smallest having shells with diameters of about 6 ft., while the largest diameter used is about 16 ft. The largest boilers have three and four corrugated furnaces.

Two types of **externally fired, return-tubular** (or "H.R.T.") boilers are shown in Figs. 213 and 214. The

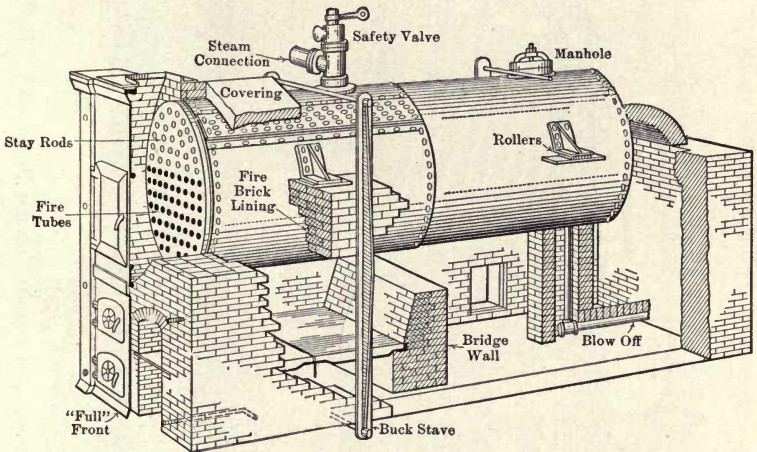

FIG. 213.—Horizontal Return-tubular Boiler with "Full Flush Front."

only essential differences in these two types are in the forms of setting and in the methods of suspending the boilers. The shell is generally rigidly supported at the furnace end and arrangements made to allow for movement of the other end with changes of temperature.

These boilers can be built very cheaply and are therefore widely used when their limitations do not prevent. It has been found inadvisable to build them in sizes larger than 200 boiler horse-power or for pressures higher than 150 lbs. per square inch, and they are generally used in smaller

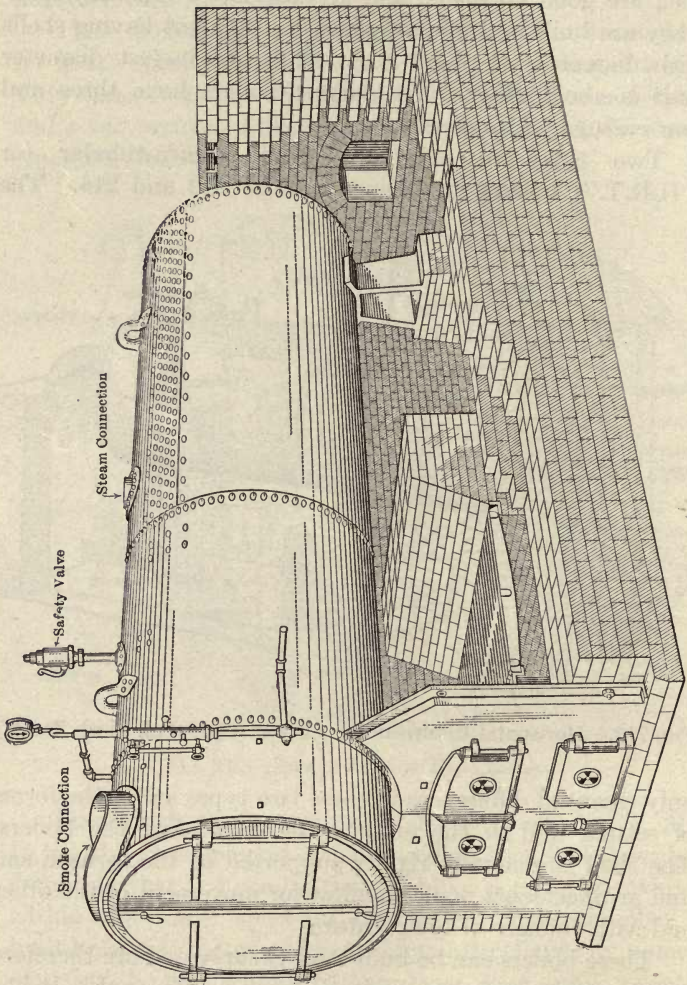

FIG. 214.—Horizontal Return Tubular Boiler with "Half Front."

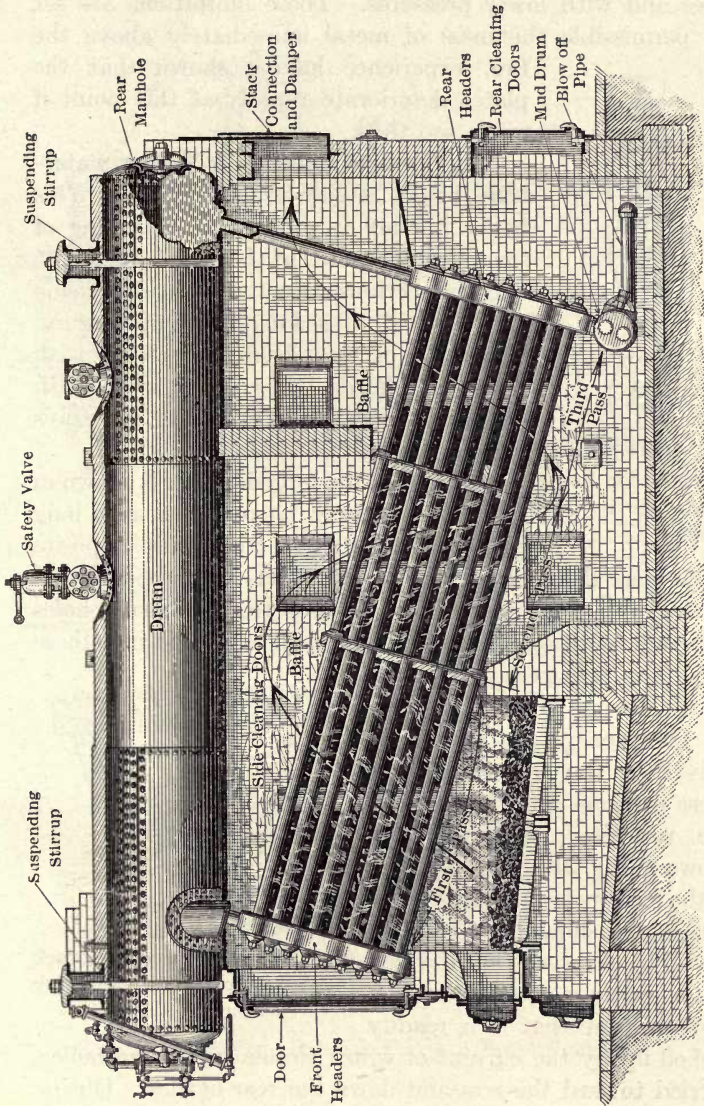

FIG. 215.—Babcock & Wilcox Water-tube Boiler.

sizes and with lower pressures. These limitations are set by permissible thickness of metal immediately above the fire, experience having shown that the plates deteriorate rapidly at this point if made too thick.



FIG. 216.—Forged Header for Babcock & Wilcox Boiler.

One form of **Babcock & Wilcox water-tube boiler** is shown in Fig. 215. This boiler is built up of sections consisting of several tubes joined at the ends by headers, and the sections are connected side by side at each end to a long horizontal drum. The ends of this drum are closed with “dished” heads, thus doing away with flat surfaces and the necessity for stays within the drum.

A detail of the forged header is shown in Fig. 216. It may be regarded as a long box of rectangular section with opposite walls pierced by circular holes, which has been so distorted as to give it a wavy shape. The distortion brings the holes into such positions that the tubes when expanded into these holes are “staggered,” that is, do not lie one above the other.

The general principle involved in the arrangement of these sections or elements and the resulting circulation are shown in Fig. 217. The location of the feed-water inlet and other details are shown in Fig. 218. It will be observed that the feed water enters in such a direction and position that it is readily picked up by the current of water circulating in the boiler, carried toward the rear and down the rear header. During this travel it is heated by contact with the hot water in

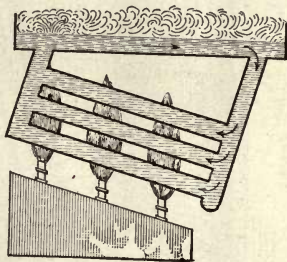

FIG. 217.—Elementary Babcock & Wilcox Boiler, Showing Circulation.

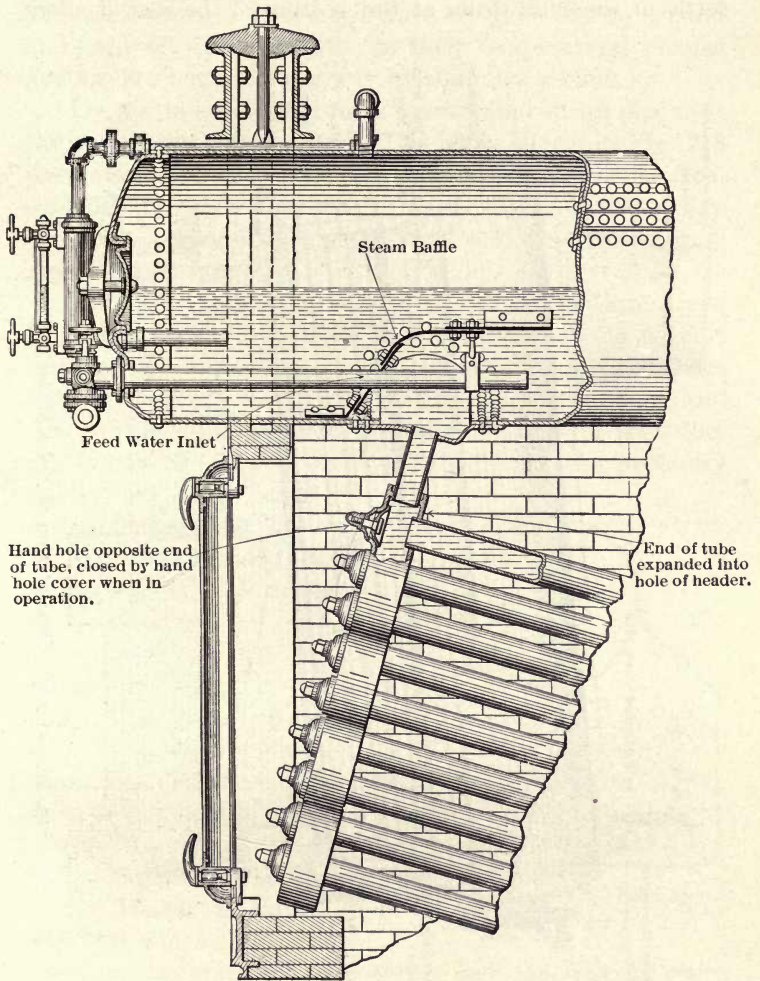

FIG. 218.—Details of Babcock & Wilcox Boiler Construction.

the boiler and most of its impurities are separated out and settle in the mud drum at the bottom of the rear header.

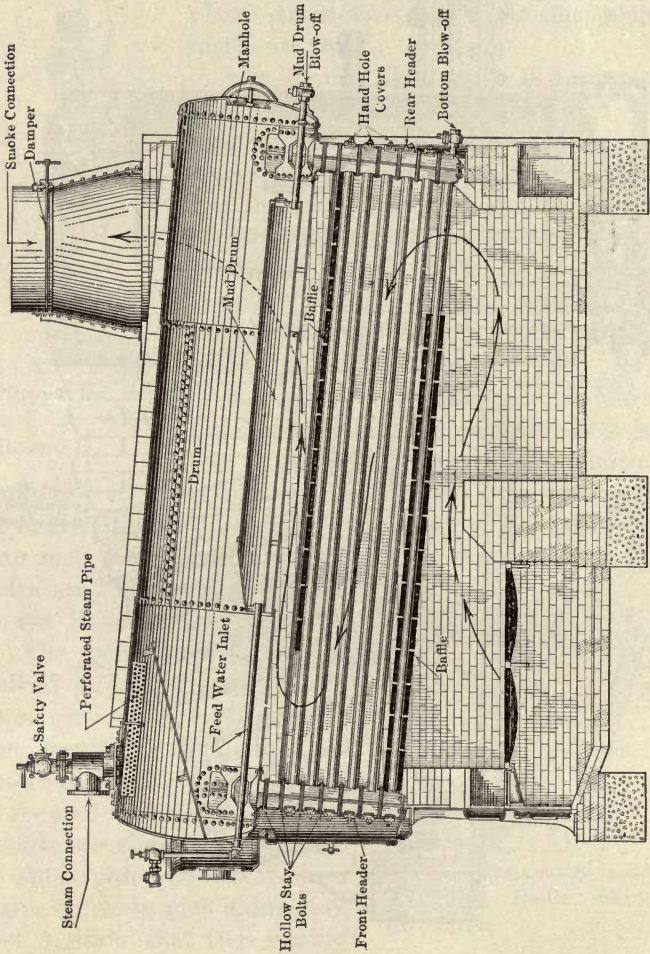

FIG. 219.—Longitudinal Section of Heine Boiler and Setting.

The boiler is suspended by stirrups from beams carried by the brickwork as shown in Fig. 215, the tube sections

simply hanging from the drum by the nipples at each end. The various parts of the structure are thus free to expand and contract independently as their temperatures change and are not bound in any way by the brick setting.

The steam is collected from a perforated steam pipe near the top of the steam space. The baffle shown in Fig. 218 prevents the steam which rises from the front header from carrying the water bodily into the steam space and makes the greater part of the water surface in the drum act as separating surface.

The scale which accumulates inside of the tube is removed by tools inserted through the hand holes in the front headers opposite the ends of the tubes. One of these hand holes and its cover are shown in section in Fig. 218. Soot and dust which accumulate on the outer surfaces of the tubes are blown off periodically by a steam jet, the necessary nozzle and hose being inserted through the tall and narrow side cleaning doors shown in Fig. 215 opposite each "pass."

A section of the **Heine water-tube boiler** is shown in Fig. 219. This boiler consists of a slightly inclined drum with dished heads, two sheet-steel headers and numerous tubes connecting these headers. The shape of the header is shown in Fig. 220, which indicates the positions occupied by the tubes and the way in which the header is joined to the drum.

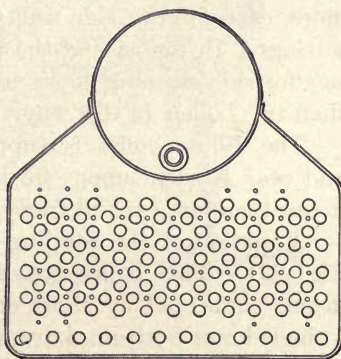

FIG. 220.—Front End Elevation, Heine Boiler.

The products of combustion are generally made to pass along the tubes by the longitudinal baffles shown, instead of across the tubes as in the boiler last described.

The mud drum in this type is located within the boiler and consists of a sheet-steel box supported a few inches above the bottom of the drum. The feed water enters at the front end of this drum and gradually spreads out as it is heated by the surrounding water. The greater part of the impurities settles to the bottom and is blown off periodically. The warmed water rises and flows out of an opening in the top of the box at the front end and there joins the circulation of the boiler, traveling toward the rear, down the rear header and up the tubes to the front header.

The interior of the tubes is cleaned of scale through hand holes just as in the last boiler. The external surfaces are freed of soot and dust by means of a steam jet which is introduced through the stay bolts in the headers, these bolts being made hollow for this purpose. Since it is not necessary to use doors in the side walls for cleaning in this type, Heine boilers are often set up in batteries of three or more, each interior side wall serving as the side wall of two settings. In the case of the boiler last described the necessity for side cleaning doors makes it impossible to join more than two boilers in this way.

The Heine boiler is supported by standing the front and rear headers upon the brickwork of the setting and it can therefore expand freely in all directions.

A section of the **Sterling water-tube boiler** is shown in Fig. 221. This boiler consists of three upper horizontal drums connected by short curved tubes and connected to a single lower horizontal drum by means of long tubes which are curved near the ends. The curves of all tubes are so made that the tubes enter the drum surfaces radially, thus giving a simple joint which is readily made tight by expanding the tube into the sheet.

The feed water is introduced into the upper rear drum, and is gradually heated and partly purified as it passes downward to the lower drum, in which the greater part of the material precipitated from the water is caught and

stored until blown off. From the lower drum the water is supposed to pass upward through the front bank of tubes, the steam formed passing to the central drum through the upper set of short curved tubes, and the water which is not evaporated passing to the central drum through the

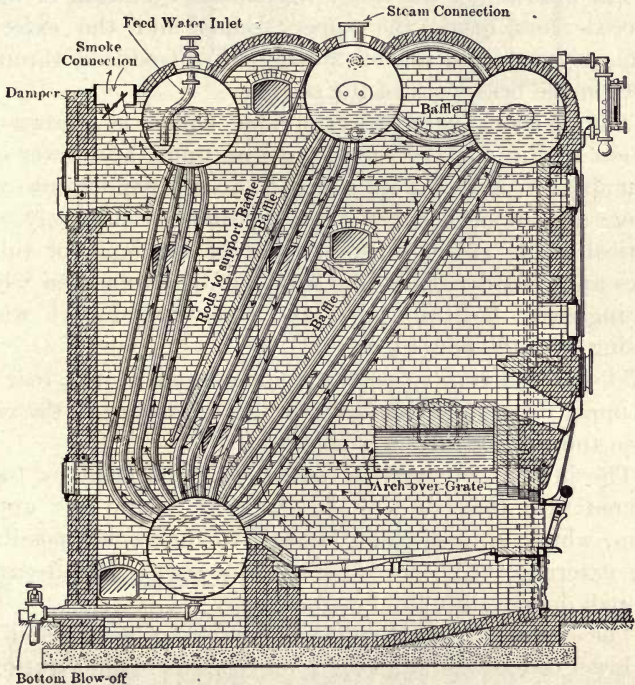

FIG. 221 —Section of Sterling Boiler.

lower set of curved tubes. This water passes from the upper central drum to the lower and returns through the front bank of tubes. Any steam formed in the rear bank of tubes or in the rear drum passes to the central drum through the short curved tubes connecting the steam spaces.

The entire boiling vessel is hung from a frame of structural steel by means of the upper drums, so that the lower

drum hangs practically free on the tubes. Independent expansion of all the members is insured by this method of suspension and by the curvature of the tubes, which permits each one of them to bend to the extent necessary to equalize any strains caused by changing temperatures.

The interiors of the tubes are cleaned by means of tools lowered from inside the upper drums and the exterior surfaces are blown off by steam jets introduced through doors in the brickwork of the setting.

The **Wickes vertical water-tube boiler** is shown in section in Fig. 222. It consists of an upper and lower circular drum, connected by straight tubes expanded into the lower and upper heads of the drums respectively. A vertical baffle placed in the center of the bank of tubes gives an upward path to the products of combustion when passing over the front tubes and a downward path when passing over the rear tubes.

The feed water is generally introduced at the rear of the upper drum, the circulation being downward in the rear tubes and upward in the front tubes.

The interior surfaces of the tubes are cleaned by tools lowered into them by a man standing within the upper drum, which is made high enough to make this possible. The external surfaces are cleaned by steam jets inserted through doors in the brickwork.

The entire boiler is supported on brackets riveted to the lower or mud drum and is free to expand in all directions, the brickwork simply enclosing but not confining it.

149. Boiler Rating. Practically all apparatus which is connected with the development of power is given a *horse-power* rating. In some cases such a method of rating is convenient and simple, in others it is inconvenient, irrational and complicated. The term horse-power, when used as a measure of work or power, means very definitely the equivalent of 33,000 ft.-lbs. per minute. When, however, a certain number of horse-power is used as the rating of a

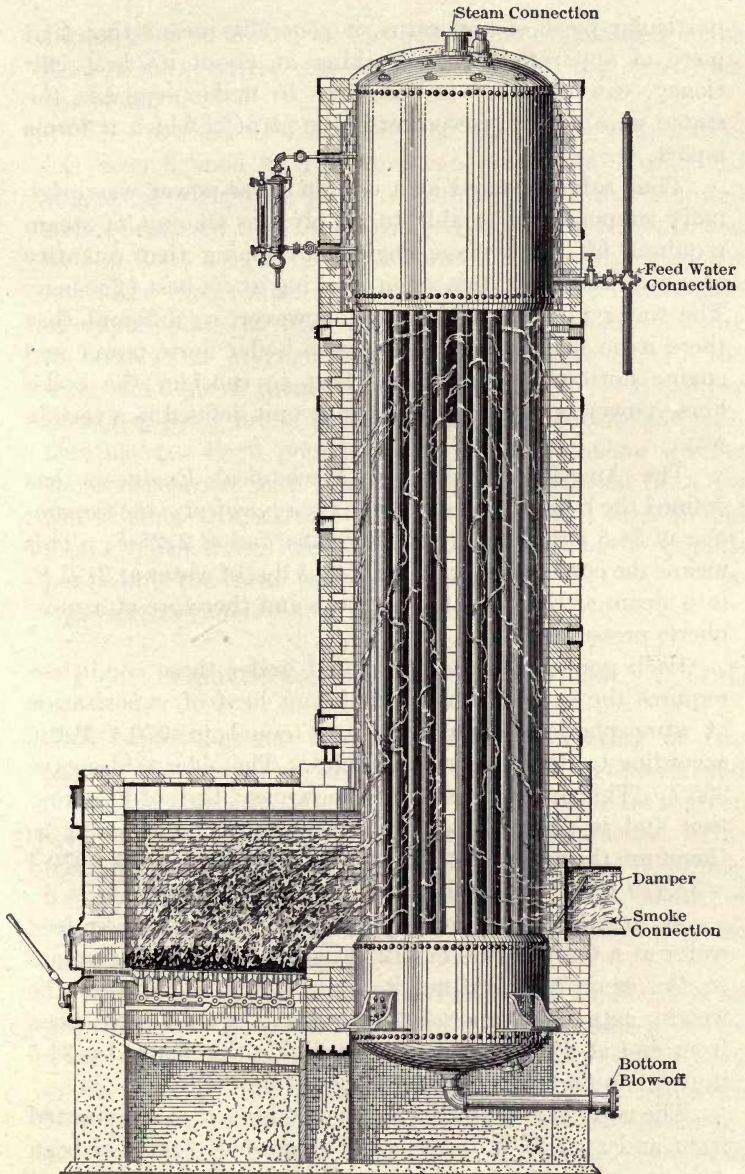

FIG. 222.—Wickes Vertical Boiler.

particular piece of apparatus, it generally means that that piece of apparatus, when working at about its best efficiency, can do what is necessary to make available the stated number of horse-power in the plant of which it forms a part.

Thus a boiler rated at a certain horse-power was originally supposed to be able to supply the amount of steam required by an average engine developing that quantity of power and to do this when working at its best efficiency. The water rates of engines are, however, so different that there is no real connection between boiler horse-power and engine horse-power, and it is best to consider the boiler horse-power as a perfectly arbitrary unit defined in a certain way.

The American Society of Mechanical Engineers has defined the **boiler horse-power** as the *equivalent of the evaporation of 34.5 lbs. of water per hour from and at 212° F.* This means the conversion per hour of 34.5 lbs. of water at 212° F. into steam at the same temperature and therefore at atmospheric pressure.

Each pound of steam generated under these conditions requires the expenditure of the latent heat of vaporization at atmospheric pressure, which is equal to 970.4 B.t.u. according to the latest steam tables. The older tables gave 965.7. This quantity of heat is known as a Unit of Evaporation and is abbreviated U.E. The boiler horse-power is, therefore, the equivalent of 34.5 U.E. per hour or $34.5 \times 970.4 = 33,479$ B.t.u. per hour.

As practically no power-plant boilers receive their feed water at a temperature of 212° F. and convert it into steam at the same temperature, it is necessary to convert the weight actually evaporated to what it would have been from and at 212° F. and then to divide this figure by 34.5 in order to find the boiler horse-power developed.

The number of pounds which would have been evaporated from and at 212° F. if the same amount of heat had been

transmitted is known as the **equivalent evaporation**, or as the *equivalent weight of water evaporated into dry steam from and at 212° F.*

The method of obtaining the equivalent evaporation has been defined by the American Society of Mechanical Engineers. The heat given to each pound of dry saturated steam produced is to be determined; this is to be multiplied by the total weight of dry saturated steam generated per hour, and the product is to be divided by the latent heat of vaporization at 212° F. Thus, for a boiler receiving its feed water at some temperature t_f above 32° F., the water contains a quantity of heat equal to q_f B.t.u. per pound, q_f being found in the steam table opposite the temperature t_f . Each pound of dry saturated steam leaving the boiler carries with it an amount of heat equal to λ for the existing temperature. The heat supplied each pound in the boiler must therefore be $\lambda - q_f$ and, for W pounds per hour, the heat supplied would be $W(\lambda - q_f)$. The equivalent evaporation is then given by

$$\text{Equiv. evap.} = W \left(\frac{\lambda - q_f}{970.4} \right) \text{ lbs. per hour.} \quad (101)$$

This expression may be regarded as consisting of two factors, the weight of dry steam generated per hour, and a fraction which will always have the same value for a given combination of pressure and feed-water temperature. This fraction is called the factor of evaporation, and it is customary to tabulate the various values of the factor of evaporation for different common combinations of pressure and feed-water temperature.

It should be noted that the equivalent evaporation as defined above gives the boiler no credit for heat given to water which leaves the boiler as water, nor does it give credit for any superheating. The former may be justified by saying that the boiler, as a commercial piece of apparatus, is not intended to supply hot water; but many commercial

boilers are expected to supply superheated steam and should be given credit for heat used in that way.

Returning now to the boiler horse-power, its value can obviously be found for any given boiler by dividing the equivalent evaporation per hour by the number 34.5.

Boilers are supposed to be so rated that they will develop their rated horse-power when operating at about their best efficiency and will do it with moderate draft and reasonably good firing with average fuel. Experience has shown that for most boilers the best efficiency is obtained when an equivalent evaporation of from 3 to 3.5 lbs. of water occurs per square foot of heating surface. The heating surface is generally taken as the total surface in contact with hot gases excepting in the case of tubes. The outer surfaces of tubes are generally counted even if they be in contact with the water. An equivalent evaporation of 3 to 3.5 lbs. per square foot would call for a heating surface of from 12 to 10 sq.ft. per boiler horse-power.

Most water-tube boilers are given 10 sq.ft. of heating surface per rated boiler horse-power, and most return-tubular boilers are supplied with 11 to 12 sq.ft. Scotch marine boilers are generally designed on a basis of about 8 sq.ft. per rated boiler horse-power.

The quantity of water which can be evaporated per square foot seems to depend to a great extent upon the rate at which hot gases can be passed over the heating surface, and experiments have shown that from five to eight times the ordinary rates of evaporation can be attained if sufficient fuel can be burned. As the rate of evaporation per square foot is increased above the commonly accepted value, the efficiency decreases, but the decrease is generally small for a considerable increase in rate of evaporation. Most power-plant boilers can give from 150 to 200 per cent of their normal rating, and some are now being installed to operate for long periods at about 200 per cent of what would be considered a normal rating.

150. Boiler Efficiencies. There are a great many possible efficiencies which may be considered in connection with boiler tests. The two most commonly used are defined by the A.S.M.E., and are:

1. Efficiency of the boiler

$$= \frac{\text{Heat absorbed per pound of combustible burned}}{\text{Calorific value of 1 lb. of combustible}}$$

2. Efficiency of boiler and grate

$$= \frac{\text{Heat absorbed per pound fuel}}{\text{Calorific value of 1 lb. of fuel}}$$

The names used are not very well chosen, and it is better to call the first the *efficiency based on combustible* and the second the *efficiency based on coal*. The weight of combustible burned is calculated by subtracting from the coal fired the total weight of moisture and the total weight of refuse in the ash pit.

The heat absorbed is by definition the heat absorbed by the dry steam made by the boiler, but it seems probable that this will also be modified in the near future as suggested in a preceding paragraph.

It is also possible to determine the efficiency of the grate, of the furnace, and of the boiling vessel, and this is sometimes done.

The best commercial operating values for the efficiency of the boiler as a whole, that is, the boiler and grate on the basis of total fuel fired, are about 75 per cent for good qualities of coal and 80 per cent for oil, but such values are generally obtained only in well-equipped plants operating on comparatively constant loads. Average commercial values generally range from 60 to 70 per cent on a yearly basis in well-equipped plants which are carefully operated, and many boiler plants are operated at an efficiency of 50 per cent and less.

The pounds of water evaporated per pound of coal

fired generally ranges between 6 and 10, and the equivalent evaporation per pound of combustible burned will generally fall between 8 and 12 pounds.

151. Effects of Soot and Scale. The flue gases in real boilers are seldom clean mixtures of the products of combustion and nitrogen, as theory would indicate. They always contain more or less soot and unburned hydrocarbons, as well as some finely powdered ash and fuel. With strong draught, very large particles of ash and fuel may be carried by the flue gases.

These materials are partly carried up the stack by the gases and partly deposited on the heating surfaces of the boiler. Such deposits decrease the conductivity of the heating surfaces, and if the deposits are heavy the loss may be very great. The results of one investigation on the effect of soot are given in Table XV, the values being taken from an article published in the Proceedings of the Institute of Marine Engineers for the year 1908. These values are probably too high, particularly for the thicker deposits, but they serve to bring out the fact that a very appreciable loss does occur from the presence of such deposits.

TABLE XV

EFFECT OF SOOT DEPOSITS ON BOILER HEATING SURFACES

Thickness of Deposit in Inches.	Loss of Conductivity in Per cent.
0	0.0
$\frac{1}{32}$	9.5
$\frac{1}{16}$	26.2
$\frac{1}{8}$	45.2
$\frac{3}{16}$	69.0

The effect of soot deposits in decreasing the efficiency of boilers was used for a long time as a basis for argument in favor of certain types of boilers in which the heating surfaces were so shaped and located that such deposits

formed to a minimum degree and against other types less favorably designed from this point of view. Practically, however, the removal of such deposits by means of steam jets applied at regular intervals is so simple that this consideration need be given little weight in the selection of a boiler. Provision should always be made, however, for the easy use of the jets for cleaning purposes.

152. Scale. Practically all water available for boiler feed contains various salts in solution and it often contains solid matter in suspension as well. This material is all deposited within the boiler as the water is heated and converted into steam. There is thus a gradual collection within the boiler of all the solid material brought in by the water.

In well-designed boilers the greater part of such deposits is carried to a part of the boiler in which the metallic surfaces are not exposed to high temperature gases, as, for instance, the mud drums in water-tube boilers. It can then be drawn off periodically in the form of a thin mud suspended in water. In practically all boilers, however, some of the solid material will be carried to the heating surfaces exposed to high temperature gases and deposited there. Under the action of heat, the mud-like material gradually changes until, in many instances, it forms a very hard, stone-like coating on the heating surface. This is known as boiler scale.

Such deposits may cause two kinds of trouble: They may decrease the conductivity of the heating surfaces and thus decrease the efficiency of the boiler; and, because of their location on the water side of the metal, they may permit the hot gases to overheat that metal, thus weakening it. Such overheated metal often "bags" under the high internal pressure and may eventually give way with disastrous results. The mechanical structure of the scale seems to be the determining factor; scales which are easily penetrated by water have little effect, while those which are very dense and non-permeable may cause serious trouble.

Boilers should be blown down periodically to keep them as free as possible of scale-forming material, and they should be so constructed that scale which has been formed can be removed easily. Very efficient tools have been developed for removing scale from the interior and exterior surfaces of tubes, so that boilers using tubular heating surfaces are readily cleaned of scale.

153. Scale Prevention. Much of the solid material carried by water is deposited when the water is heated to a temperature of from 150° to 200° F., so that heating feed water before it is admitted to the boiler is at least a partial preventive in most cases.

Nearly all of the salts which are soluble in hot water and therefore are not deposited when the feed is heated, can be made to form insoluble compounds by the addition of comparatively cheap chemicals. By the addition of such chemicals in the feed-water heaters, or in other apparatus specially designed for that purpose, the greater part of the solid content of the water can be precipitated before it is admitted to the boiler.

There are a great many "boiler compounds" on the market which are intended to be mixed with the water as it is fed to the boiler and are supposed to prevent the formation of scale on the heating surfaces. All they can possibly do is to change the chemical composition of the solids; they cannot prevent the deposit of these solids within the boiler. They are therefore, at best, only an imperfect remedy.

154. Superheaters. Many boiler plants are now arranged to supply steam superheated 25 to 200 degrees Fahr. It was shown in an earlier chapter that the use of superheated steam greatly improves the economy of reciprocating engines and turbines, and there are also other advantages which accrue from its use.

Superheaters are of two kinds—**separately fired** and **built-in superheaters**. The separately fired superheaters are

enclosed in a brick setting fitted with grate and furnace similar to that of an ordinary boiler. The built-in superheaters are installed within the boiler setting so that the products of combustion pass over them in flowing through the boiler.

In either type the steam passes through the superheater on its way from the boilers to the engines. In the case of separately fired superheaters, the temperature of the superheated steam is controlled by regulation of the fire on the grate of the superheater, but in the built-in type regulation in this way is practically impossible, as the fire under the boiler must be controlled to suit the demand for steam. The control of such superheaters is therefore effected either by locating them in such a position that the natural variation in the temperature of the gases reaching them gives an approximate regulation, or they are installed in a separate chamber and hot gases passed over them in such proportions as necessary to give the required temperature.

The Babcock & Wilcox superheater as applied to the boiler of the same make is shown in Fig. 223. The steam collected in the dry pipe within the drum passes downward to the upper manifold of the superheater and from there it flows through the U-shaped tubes into the lower manifold. From the lower manifold it flows through the superheater stop valve to the engine or turbine.

The superheater is so located that the hot gases pass over it between the first and second passes and there is no way of shutting off these gases. Provision, as shown in the illustration, is therefore made for flooding the superheater during starting, or when superheated steam is not desired. When flooded it becomes heating surface similar to that of the tubes below, the steam made passing into the drum through the dry pipe.

The Heine superheater as applied to a Heine boiler is shown in Fig. 224. It consists of a sheet-metal header or box into which U-shaped tubes are expanded. The steam

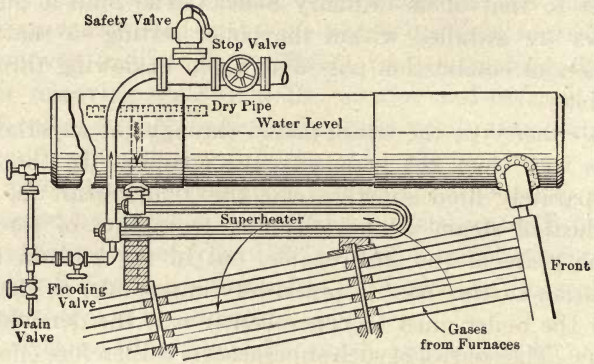

FIG. 223.

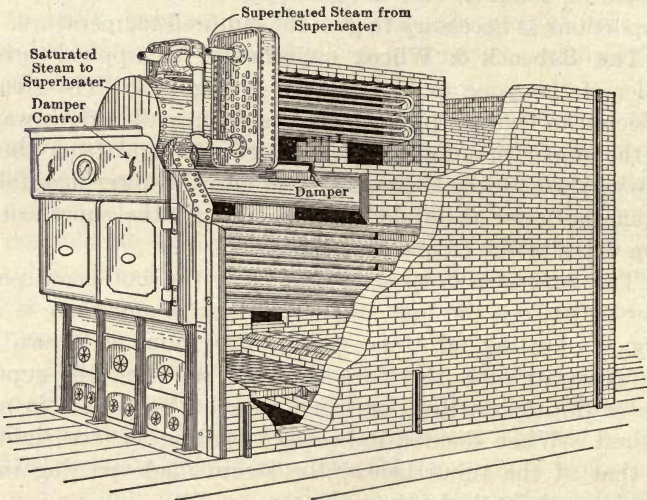

FIG. 224.—Heine Superheater.

enters the bottom of the header and is guided by diaphragms in such a way that it passes through the lower set of U-tubes, returns to the header, passes through the upper set of tubes, and then leaves the superheater at the top.

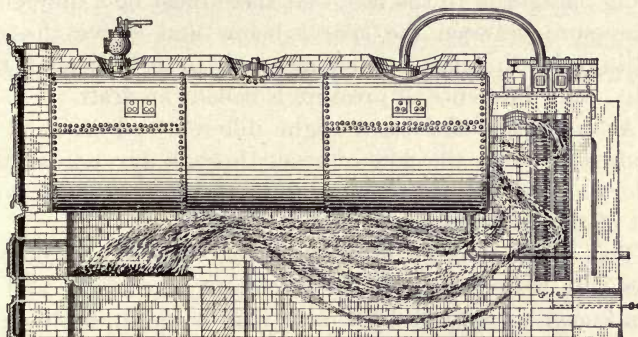

FIG. 225.—H.R.T. Boiler and Foster Superheater.

This apparatus is installed in a brick chamber built into the boiler setting and connected with the furnace by a flue (not shown) in the brick side wall. A damper controls the flow of hot gases to this chamber and the degree of superheat is controlled by the position of this damper.

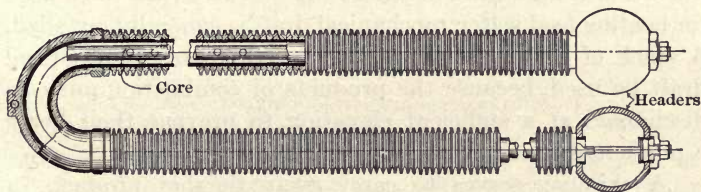

FIG. 226.—Element of Foster Superheater.

The Foster superheater is shown installed in the setting of an H.R.T. boiler in Fig. 225 and the details of the construction of one element are shown in Fig. 226. The core is used to spread the steam in a thin stream, thus bringing it into better contact with the heating surface. The fins

on the exterior of the element are used for the purpose of getting a more extended metallic surface in contact with the hot gases.

155. Draft Apparatus. Attention was called in a preceding paragraph to the fact that there must be a difference of pressure between the spaces below and above the fuel bed in order to cause the necessary air to flow through the bed. This difference of pressure is called the **draft**.

As a matter of fact, a slight difference of pressure is required to cause the flow of gases through any part of the boiler and the drop in pressure through the fuel bed is only part of the total draft required.

The draft may be created in two distinctly different ways. It may be caused by a chimney or stack, and is then known as **natural draft**, or it may be produced by fans or blowers, in which case it is called **mechanical draft**.

(a) **Chimneys or Stacks.** Stacks are practically always used in small plants because of the simplicity resulting from their use and because the interest on the investment compares favorably with interest on investment plus cost of operation for mechanical draft. In large plants fitted with some types of mechanical stokers, or where fuel is to be burned at a high rate, or where the flue gases are to be used for heating feed water, mechanical draft is generally installed. A stack of some sort is necessary even though mechanical draft be used, because the products of combustion must be discharged at a sufficient elevation to prevent their being a public nuisance.

A chimney serves to carry away the hot products of combustion and when in operation is filled with a column of gases with higher average temperature than that of the surrounding air. As a result the density of gases within the stack is less than the density of the outer air and the gas pressure at the bottom of the structure is less inside the stack than it is outside. If an opening is made at this point, the external air will therefore flow in. By arranging

the apparatus as shown in Fig. 227, the temperature of the air flowing into the bottom of the stack is raised as it passes through the furnace and the flow is thus made continuous.

The height of the chimney determines the draft created by it with flue gases of a given temperature, and, with any given height, the area determines the quantity of gas which

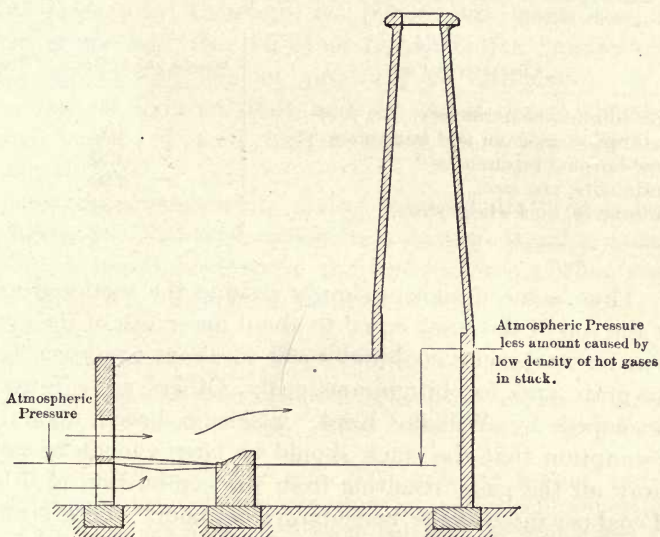

FIG. 227.—Diagrammatic Arrangement of Stack.

can be carried off in a given time. The proportions of chimneys can be determined from rational formulas based on theoretical considerations, but it is necessary to assume values for a number of constants and a proper choice depends largely upon experience.

As a result, all but the more important chimneys are generally designed on an empirical basis and many formulas have been developed for this purpose. One of the most common methods of design is to choose the height in accord-

ance with the values given in Table XVI, and then to determine the sectional area according to an empirical assumption or formula.

TABLE XVI
COMMON HEIGHTS OF CHIMNEYS

(Applicable to plants smaller than about 700 H.P. Larger installations should have stacks of from 150 to 175 feet in height unless local conditions call for greater height.)

Character of Fuel.	Height above Grate in Feet.
Free-burning bituminous	80
Anthracite, medium and large sizes	100
Slow-burning bituminous	120
Anthracite, pea size	130
Anthracite, buckwheat sizes	150

Thus, some designers simply assume the sectional area at the top of the stack equal to about one-ninth of the grate area for anthracite coal and equal to about one-seventh of the grate area for bituminous coal. Others use a formula developed by William Kent, which is based upon the assumption that the stack should be large enough to carry away all the gases resulting from the combustion of 5 lbs. of coal per rated boiler horse-power per hour. This formula gives the boiler horse-power which the stack can serve and is

$$\text{H.P.} = 3.33(A - 0.6\sqrt{A})\sqrt{H}, \quad . . . \quad (102)$$

in which

H.P. = Rated boiler horse-power;

A = Internal sectional area in feet of circular or square chimney;

H = Height above grate in feet.

(b) **Mechanical Draft.** Fans can be so used as to force air into the ash pit, that is, to raise the pressure on the

entering side of the fire. In such cases the equipment is said to give forced draft. Or fans may be installed at the discharge end of the flues and may "draw" the gases through the boiler by lowering the pressure within to a value below that of the external atmosphere. Such an installation is said to give induced draft.

Forced draft suffers from the disadvantage that the pressure within the furnace is greater than atmospheric and hot gases may therefore be blown out when the fire door is opened. On the other hand, the fan handles only cool air instead of hot products of combustion as in the case of induced draft and its useful life is therefore much longer. Forced draft is much more common than induced draft.

Several arrangements giving *balanced* draft have been developed. With such apparatus a pressure equal to atmospheric is maintained above the fuel bed and no hot gases are blown out through the firing door.

PROBLEMS

1. The equivalent evaporation of a boiler during a certain test was 3450 lbs. per hour. What boiler horse-power was developed?

2. A water-tube boiler with 5000 sq.ft. of heating surface and rated in the ordinary way gave an equivalent evaporation of 25,875 lbs. per hour. At what per cent of rating was the boiler operating?

3. A certain boiler produced 3500 lbs. of dry steam in one hour from feed water at a temperature of 50° F. The steam pressure was 200 lbs. per square inch gauge. What was the equivalent evaporation?

4. A boiler receiving water at a temperature of 250° F. converts it into superheated steam at a pressure of 210 lbs. per square inch gauge and a temperature of 580° F. The boiler produces 26,000 lbs. of steam per hour. What is the equivalent evaporation if the boiler is given credit for all the heat given the material passing through it? What boiler horse-power is developed!

5. A boiler produces 7.5 lbs. of dry steam per pound of coal fired. The feed-water temperature is 80° F, and the steam pres-

sure is 125 lbs. per square inch absolute. What is the equivalent evaporation per pound of coal?

6. A boiler is supplied with coal which has a calorific value of 13,520 B.t.u. per pound. It produces 8 lbs. of dry saturated steam at a pressure of 150 lbs. per square inch gauge per pound of coal. The feed-water temperature is 70° F. What is the efficiency of the outfit?

CHAPTER XVIII

RECOVERY OF WASTE HEAT

156. Waste Heat in Steam Plant. There are two great heat wastes in the steam plant—the waste in the hot gases going up the stack and the waste in exhaust steam. The magnitude of the stack loss can best be appreciated by determining an approximate value for assumed conditions. For this purpose assume the fuel to be pure carbon, the excess coefficient 1.5, average atmospheric temperature 60° F., average stack temperature 600° F., and no moisture in the air. The specific heat of the flue gases may be taken as constant and equal to 0.24.

With an excess coefficient of 1.5, the total weight of flue gas per pound of carbon burned would be about 18.4 lbs. and the heat carried up the stack figured above room temperature would be

$$\begin{aligned}\text{Stack loss} &= 18.4 \times 0.24 (600 - 60). \\ &= 2380 \text{ B.t.u. per pound of C burned (approx.)}\end{aligned}$$

With a calorific value of 14,600 B.t.u. per pound of carbon this loss would be equivalent to a little over 16 per cent of the total heat in the fuel.

It would be more correct to use the temperature of the steam in the boiler instead of room temperature, because the lowest temperature theoretically attainable by gases passing through a boiler would be equal to that of the steam and water on the other side of the heating surface. Under ordinary conditions of operation, this method of figuring would give a theoretically avoidable stack loss equal to about 50 per cent of the figure obtained above.

The magnitude of the exhaust loss can be similarly approximated. Assume for this purpose an engine receiving dry saturated steam at 115 lbs. absolute per square inch and exhausting it with a quality of 90 per cent at a pressure of 15 lbs. absolute per square inch.

The heat above 32° in the entering steam is 1188.8 B.t.u. per pound and the heat exhausted per pound is 1053.7. The heat in the exhaust represents therefore about 89 per cent of all the heat supplied when calculations are made above a temperature of 32° F. If a feed-water temperature of 60° be assumed and heat quantities be figured above that datum the results are practically the same.

There are always numerous pieces of auxiliary apparatus in steam plants such as boiler-feed pumps, circulating pumps, vacuum pumps, etc. These are often steam driven and are generally very uneconomical in the use of heat, so that they throw away in their exhaust steam large quantities of heat originally transferred from fuel to water and steam in the boiler.

157. Utilization of Exhaust for Heating Buildings. It often happens that steam-power plants are located within or in the neighborhood of buildings requiring artificial heat during part of the year. In such cases the exhaust steam from main and auxiliary engines can generally be advantageously used for this purpose. Under particularly favorable circumstances, the weight of steam required by the plant may equal approximately that required for heating, and the greater part of the exhaust could then be turned directly into the heating system.

The engines in plants of this character may be regarded as reducing valves for the heating system, receiving steam at high pressure and reducing the pressure to the value best adapted to the heating system installed. If the comparatively small losses arising from radiation from the engine, from friction and from the presence of hot water in the exhaust be neglected, all heat received by the engine

and not turned into useful mechanical energy is made use of in the heating system. The engine may therefore be very uneconomical in the use of steam and still not cause a waste of fuel, provided always that the heating system can absorb all heat exhausted.

Since the demands of a heating system vary from day to day and since there is generally no demand for heat during several months of each year, it follows that a high degree of skill is necessary in choosing the character of the apparatus installed. A compromise is generally made between the cheap and uneconomical engine allowable during the coldest months and the more expensive and more efficient engine desirable when no heating is to be done.

There are other cases of somewhat similar character. In many industries use can be made of exhaust steam for the heating of evaporating pans, dye vats, kilns and other apparatus. Steam plants of an uneconomical character may be very economical financially in connection with such industries if all or nearly all of the heat in the exhaust can be utilized industrially.

158. Feed-water Heating. An examination of the steam table will show that the total heat above 32° F. per pound of steam varies between 1180 and 1200 B.t.u. for such pressures as are commonly used in boilers. The average temperature of water as it occurs on the surface of the earth is probably somewhere in the neighborhood of 60° , so that the heat above 32° per pound would roughly average 27 B.t.u. A boiler receiving water at 60° and converting it into steam at any of the ordinary pressures must therefore supply over 1100 B.t.u. per pound of water.

This immediately suggests a use for heat in exhaust steam. Steam exhausted into very low vacuums has a temperature only 10° to 30° higher than the assumed average natural feed temperature, but steam exhausted at atmospheric pressure has a temperature of 212° F. and could therefore impart large quantities of heat to water at 60° F.

Since the boiler must supply over 1100 B.t.u. per pound of steam made, raising the feed temperature about 11° or 12° should effect a saving of about 1 per cent in fuel consumption. By raising the temperature from 60° to 212° there should therefore result a saving of approximately 13 to 14 per cent.

Other advantages which would accrue from this preliminary heating of the feed water would be (1) the deposit, outside of the boiler, of a large amount of the solid matter carried by the water, (2) the use of fewer or smaller boilers, and (3) the reduction of the strains which occur in the metal of some designs when very cold feed water is used.

Exhaust steam feed-water heaters are divided into two types, *open* and *closed heaters*. In **open heaters** the steam and feed water are brought into intimate contact in the form of jets, sheets and sprays within a vessel of appropriate size and shape. They are often called contact heaters. When the exhaust steam comes from reciprocating engines it always carries in suspension some of the oil used for lubricating the engine cylinders. If allowed to enter the heater, this oil would mix with the feed water and eventually reach the boilers, where it might cause serious damage by depositing upon heating surfaces exposed to the fire or to very hot gases. Such heaters are therefore always fitted with oil or grease extractors when used with reciprocating units. When receiving the exhaust from turbines, oil extractors are not necessary, as no lubricant is used within the steam spaces of such units.

Closed heaters consist of tubes or coils enclosed within a metal vessel. One medium passes through the tubes and the other over their outer surfaces. Such heaters are therefore often called non-contact heaters.

As oil is a poor conductor of heat, the exhaust steam from reciprocating units should be passed through an oil extractor before entering a closed heater in order that the heating surfaces may be used to the best advantage.

Exhaust steam feed-water heaters are often divided into *primary* and *secondary heaters*. This distinction has nothing to do with structure, being based entirely on position and temperature. Thus there may be available exhaust steam at a pressure below atmospheric, as from condensing main units, and exhaust steam at atmospheric pressure from non-condensing auxiliaries. The lower pressure steam could be used to heat the feed water in a primary heater and the higher pressure steam could then raise its temperature still further in a second or secondary heater.

The other great waste, that in the stack gases, can also be partly eliminated by using some of it to heat the feed water. As the highest steam temperature ordinarily available in the exhaust system is about 212° F., and as the products of combustion leaving the boilers generally have temperatures in the neighborhood of 600° to 700° F., it is evident that on a basis of temperature the hot gases have a decided advantage as a heating medium. On the other hand, the specific heat of the hot gases is low, while exhaust steam can give up all of its latent heat with no change in temperature, so that on a basis of heat available for transmission to the water, the steam has the advantage.

The waste heat in the flue gases is used for feed-water heating in devices known as economizers. These generally consist of groups of tubes, joined at their ends by headers and standing vertically within sheet-metal flues leading from the gas passages of the boilers to the chimney. The water to be heated is pumped through the tubes on its way to the boilers and the hot gases flow over the tubes on their way to the chimney. Mechanically operated scrapers are arranged to travel up and down the tubes at intervals and keep their external surfaces free of soot and dust, which would seriously reduce their ability to transmit heat.

The feed water supplied the economizer is generally first heated in an exhaust steam heater and arrives at the

economizer with temperatures between about 120° and 200° F., depending upon the kind of heaters used and upon the relative quantities of exhaust steam and feed water. The economizer discharges the water to the boiler at temperatures which generally run from about 210° to 300° F., depending upon the amount of preliminary heating, the extent of economizer surface and a number of other variables.

The gases which have passed through an economizer often have temperatures as low as 250 to 350° F., which is generally too low a value to give good chimney draft. Plants making extensive use of economizers are therefore generally fitted with some form of mechanical draft.

PROBLEMS

1. Determine the heat lost in the chimney gases per pound of coal in a plant operating under the following conditions, and express the loss as a percentage of the heat value of the coal. The coal has a calorific value of 14,000 B.t.u. per pound; the temperature of the gases leaving the boiler is 570° F.; 20 lbs. of gas result from each pound of coal burned; the mean value of the specific heat of the gases is 0.245; and the temperature of the air entering the furnace is 75° F.

2. Determine the quantity of heat which could be obtained from the gases of Prob. 1 by using an economizer to reduce their temperature to 250° F. What percentage of the heat value of a pound of coal does this saving represent?

3. The boilers of a certain plant produce 100,000 pounds of steam per hour when the plant is operating at full load. The steam-driven auxiliaries consume 10% of this steam. Steam is generated at a pressure of 175 lbs. per square inch gauge, and is superheated 150° F. The main units operate condensing and the condensate leaves the condensers at a temperature of 75° F. The auxiliaries operate non-condensing and exhaust their steam at atmospheric pressure and with a quality of 92%. The coal used has a calorific value of 13,850 B.t.u. The boiler efficiency $\left(\frac{\text{Heat given water and steam}}{\text{Heat in fuel supplied}} \right)$ is 75%.

(a) Determine the amount of coal which would have to be burned per hour if the steam exhausted from the auxiliaries were thrown away and make-up water at a temperature of 50° F. were

used in its place. The condensate from the condensers of the main unit is assumed to be returned to the boiler after being mixed with the make-up water.

(b) Determine the amount of coal which would have to be burned per hour if the auxiliary exhaust were used to heat the condensate from the main units in an open heater and if the operation of the plant were so perfect that no make-up water had to be added.

CHAPTER XIX

BOILER-FEED PUMPS AND OTHER AUXILIARIES

159. Boiler-feed Pumps. The pumps used for forcing the feed water into boilers may be of reciprocating or centrifugal construction and may be driven by reciprocating steam cylinders, by small steam turbines or by electric motors.

Steam-driven pumps are very wasteful, often using over 100 lbs. of steam per horse-power hour. It would therefore seem more economical to use motor-driven pumps in electric-power stations, as the large power units will generate electric power with a consumption of from 10 to 25 lbs. of steam per horse-power hour and the motor efficiency will generally be over 80 per cent. There is, however, another point which must be considered. The exhaust steam from small engines operating boiler-feed pumps can be used for heating the feed water as described in the last chapter, and thus the poor economy of these units is of little significance; practically all heat exhausted can be returned to the boiler in the boiler feed if desirable. As a result of this consideration, coupled with others of less importance, nearly all boiler-feed pumps and other similar auxiliaries are steam driven unless there are so many that there would be more exhaust steam than could be absorbed by the feed water.

There is at present a marked tendency toward the use of turbine-driven, centrifugal pumps for boiler feeding, in place of those driven by reciprocating steam units. The turbine type has several advantages, the more important being:

(1) No oil in exhaust steam, so that latter is well adapted to use in all forms of feed-water heaters;

(2) Higher speed because of continuous flow of water and continuous rotation of mechanical parts, thus making possible great decrease in size for a given amount of work, and

(3) Better pump characteristics for this sort of work.

The Duplex Steam Pump. The great majority of reciprocating steam pumps used for boiler-feed purposes are of the duplex pattern, one design of which is shown in Figs.

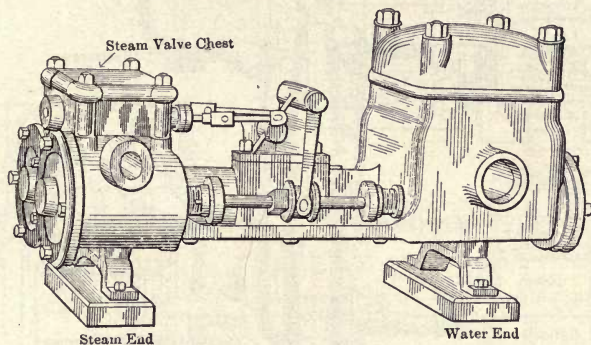

FIG. 228.—Duplex Steam Pump.

228 and 229. Two steam cylinders are arranged side by side, their piston rods extending into similarly arranged water cylinders and carrying water plungers or pistons as shown in Fig. 229. As there is no rotating shaft in a pump of this kind, the steam valves cannot be operated by eccentrics as is common with steam engines. For the purpose of operating these valves, bell cranks, pivoted near the center of length of the pump, are provided. These are arranged so that the long arm of one bell crank engages a collar on the piston rod of one steam cylinder and the short arm operates the valve gear of the other steam cylinder. The motion of the valve of one cylinder is therefore derived

from the piston motion of the other cylinder. The steam pistons are practically 180° out of phase, one moving out while the other moves in.

Practically no expansion of the steam is obtained in the cylinders of pumps of this type. They operate on the rectangular cycle described in an earlier chapter and are correspondingly wasteful in their use of steam.

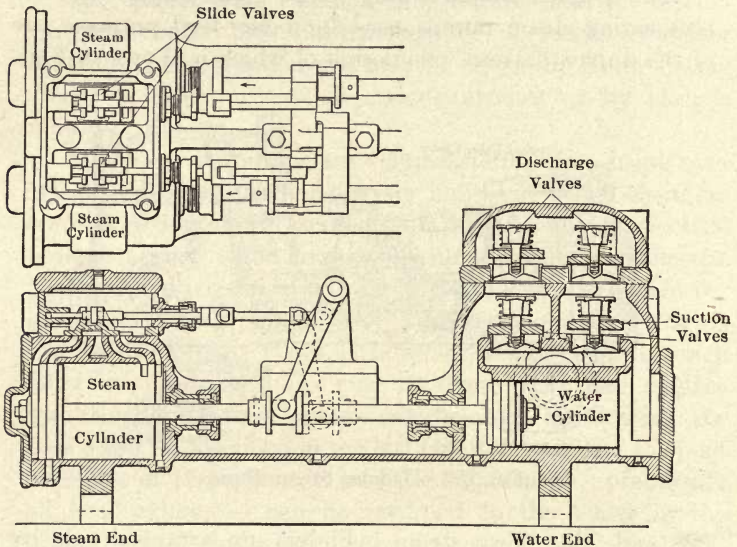

FIG. 229.—Duplex Steam Pump.

160. The Steam Injector. On steam locomotives and in other portable steam plants, as well as in many small stationary plants, a device known as a *steam injector* is used, instead of a pump, for forcing feed water into the boiler. A simple form of steam injector is shown semi-diagrammatically in Fig. 230.

Steam from the boiler flows through the steam nozzle and expands from boiler pressure to a very low pressure, thus acquiring a high velocity at the expense of the heat

energy which it brings from the boiler. At the end of the nozzle it mixes with water and imparts to that water some

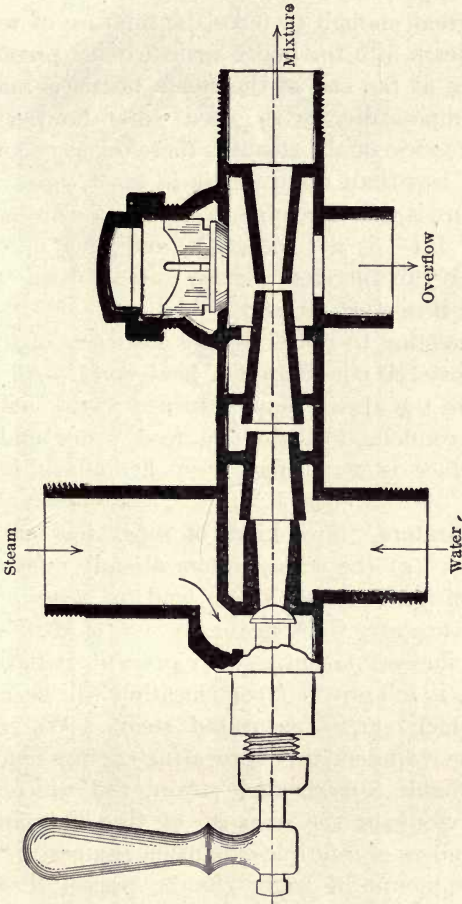

Fig. 230.—The Steam Injector.

of its kinetic energy, so that the mixture moves into the small end of the delivery tube with a high velocity. By the time it has reached that point, practically all the steam has been condensed, and, as the sectional area of the delivery

tube increases, the velocity of the liquid decreases with a corresponding increase in pressure according to Bernoulli's theorem. In properly designed apparatus, the resultant pressure is great enough to force the mixture of water and condensed steam into the boiler against boiler pressure.

The space at the end of the steam nozzle is maintained at a low temperature by the feed water flowing through it and the pressure of the steam is therefore very low at this point, being less than atmospheric in most cases. Atmospheric pressure is therefore able to force water up the suction pipe if the "lift" is not too great, and when once started such a device can therefore "raise" its own water as well as delivering it against pressure.

It is interesting to note that the efficiency of this apparatus is almost 100 per cent on a heat basis. All heat not radiated from the apparatus is returned to the boiler in the mixture of condensed steam and feed water and, as the external surface is very small, very little heat is lost by radiation.

161. Separators. Two kinds of separators are used in steam plants: (a) the *oil separators* already referred to for separating oil from exhaust steam, and (b) *steam separators*, which separate water from steam.

As it is impossible entirely to prevent radiation from steam pipes, it follows that condensation will occur in any pipe line which carries saturated steam. Water is also formed in the cylinders of reciprocating engines not supplied with very highly superheated steam, and much of it is generally present in the exhaust of the high and intermediate cylinders of multiple-expansion engines.

A small amount of water can be passed through the cylinder of a reciprocating engine without mechanical damage, but it probably causes a loss of heat by clinging to the walls and assisting in the heat interchanges which always occur. Large quantities of water are apt to cause mechanical damage, as water is inelastic, and if

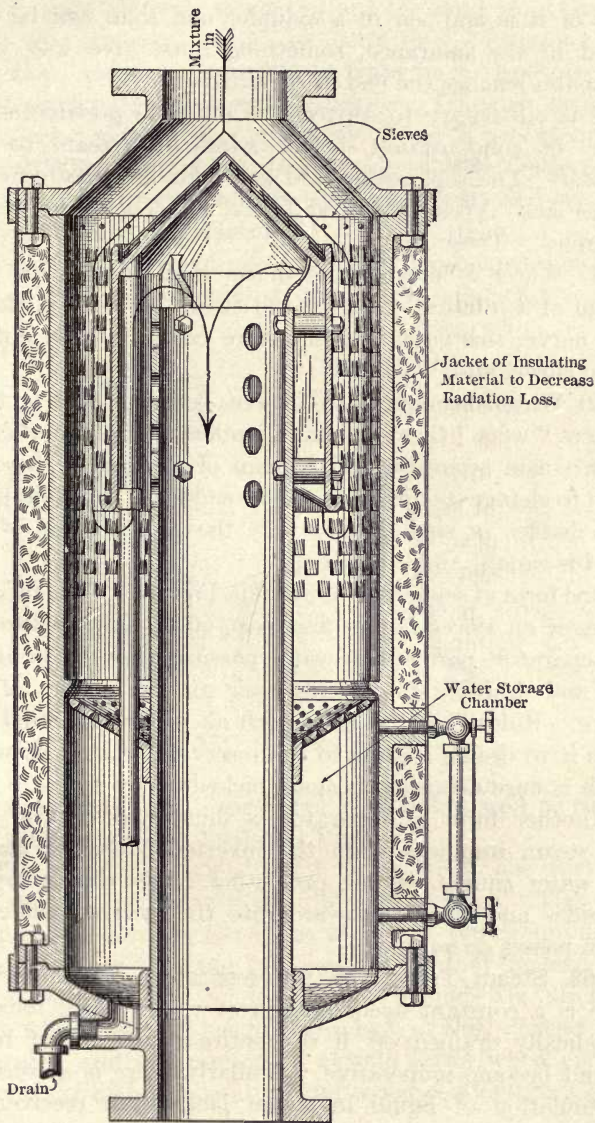

FIG. 231.—Steam Separator.

more of it is trapped in a cylinder end than can be contained in the clearance, something must give way when the piston reaches the end of its stroke.

It is customary to separate as much as possible of the water of condensation before admitting steam to the cylinder. The separators used are built in many different shapes and types, but practically all depend upon two principles. These are:

(1) Water is much more dense than steam, and if a stream of a mixture of water and steam be made to travel in a curve, the water will therefore collect at the outside of the curve, and

(2) Water brought into violent contact with metallic surfaces "wets" them and has a tendency to adhere thereto.

In steam separators the stream of mixture is therefore made to change its direction of flow suddenly and to impinge upon baffles in such a way that the greater part of the liquid is caught and drained off.

One form of separator is shown in Fig. 231. The mixture impinges on sieves in the first part of its passage through the separator, part of the water passing through the openings and draining to the reservoir at the bottom of the device. Ridges and troughs catch all water separated and guide it to drains leading to the reservoir, so that no water which is once deposited is again picked up by steam.

Another form of separator is illustrated in Fig. 232. The steam impinges upon the inverted V-shaped casting and water caught on the projecting ridges drains toward the sides and then downward into the receiver, while the steam passes on as shown.

162. Steam Traps. In the separators just described, there is a constant accumulation of water which must be periodically drained off if the entire device is not to fill up and become inoperative. Similarly there is a constant accumulation of liquid in steam jackets, in receivers of multi-expansion engines and in low points in steam lines.

To drain all such accumulations by hand from time to time, as necessary, would be both time consuming and uncertain, and devices known as traps have therefore been developed for doing this automatically. Traps are arranged to collect condensation until they fill to a predetermined point. When this occurs they automatically discharge in such a way as to prevent the escape of steam and are then ready to receive liquid again.

Traps may be arranged to receive condensation from high or low-pressure mains or from spaces in which a vacuum

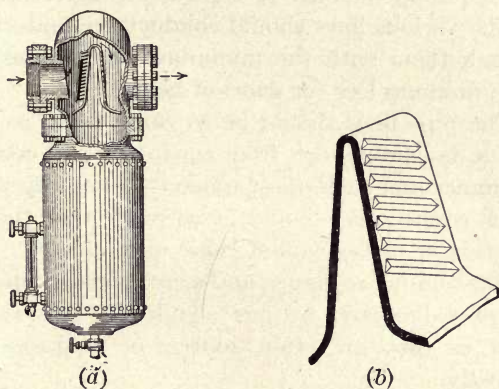

FIG. 232.—A Steam Separator.

is maintained, and to discharge it to a hot well or similar receiver or even into the boiler itself.

The principles upon which traps work are very numerous and there are many different designs. The more common either make use of the weight of the accumulating water to cause the trap to discharge, or they make use of floats resting on the condensate and opening the discharge valve when a certain height is reached, or they depend upon expansion and contraction of certain parts when exposed to steam of high temperature and cooler condensate respectively.

163. Steam Piping. There is a great deal of piping of various kinds in all steam plants and the financial success or failure of a plant often depends upon this apparently insignificant item. It is beyond the limits of a book of this scope to consider the many different forms of piping and the many different ways in which apparatus may be connected. This is a study in itself and one of great importance.

It should be noted, however, that all of the following points must be kept in view when designing and installing piping and that that installation which most nearly meets all these requirements may be regarded as the best.

(1) The various lines should conduct the materials flowing through them with the minimum loss of pressure and with the minimum loss (or gain) of heat.

(2) The pipe lines should be so constructed as to make failure of a dangerous sort, from expansion and contraction, water hammer and such, most unlikely if not impossible.

(3) All connections should be so made that the careless manipulation of valves cannot cause an accident.

(4) The number of flange and screw connections and the number of valves and fittings should be reduced to the minimum, as they are often sources of weakness and are always costly.

(5) The entire layout should be so arranged that interruption of service because of pipe, or valve, failure is (as nearly as possible) impossible.

(6) The cost of the system should be as small as it can be made, consistent with the other requirements.

It is almost unnecessary to say that all of these desirable ends are never attained in any plant. A compromise must always be made in order to bring the cost within reasonable limits, but most of the recent installations show a tendency toward better design in this part of the plant and a consideration of reliability and safety far in excess of what was formerly customary.

TABLES

TABLE GIVING THE PROPERTIES OF ONE POUND OF SATURATED STEAM

[Condensed and rearranged from Marks and Davis's STEAM TABLES AND DIAGRAMS, 1909, by permission of the publishers, Longmans, Green & Co., with addition of lines and columns as indicated by asterisks (*). The first eleven lines constitute a table based on temperatures which are so selected as to give (approximately) intervals of half an inch of Hg, in column 1, without using fractional degrees. The rest of the table is based on absolute pressures. At the heads of columns are given the alternative symbols which are often used.]

PRESSURE.		TEMP. ° F.	HEAT—BRITISH THERMAL UNITS.					ENTROPY.			SP. VOL. Cu.ft.	PRES. ABS. Lbs. Sq.in
Inches of Mer- cury.	Abs. Lbs. Sq.in.		Total.	Water.	Latent.		Total.	Liquid.	Vapor.			
					Total.	Inter- nal.				Exter- nal.		
	p	t	$\lambda(H)$	$q(h)$	$r(L)$	$\rho(I)$	APu^*	$\Delta\phi(N)$	$\Delta\phi_e(n)(\theta)^\dagger$	$\Delta\phi_v\left(\frac{r}{T}\right)\left(\frac{L}{T}\right)$	$V(v)(s)$	p
0.1804	0.0886	32	1073.4	0.0	1073.4	1019.3	54.1	2.1832	0.0000	2.1832	3294.0	
0.50	0.2472	59	1085.4	27.08	1058.3	1001.3	57.0	2.0944	0.0536	2.0408	1249.2	
1.00	0.4893	79	1094.3	47.04	1047.3	988.1	59.2	2.0358	0.0913	1.9445	657.0	
1.50	0.741	92	1100.1	60.0	1040.0	979.4	60.6	2.0007	0.1151	1.8856	442.2	
2.00	0.975	101	1104.0	68.97	1035.1	973.5	61.6	1.9776	0.1313	1.8463	341.0	
2.50	1.235	109	1107.5	76.94	1030.6	968.2	62.4	1.9678	0.1454	1.8124	272.9	
3.00	1.467	115	1110.2	82.92	1027.2	964.2	63.0	1.9435	0.1559	1.7876	231.9	
3.50	1.736	121	1112.8	88.91	1023.9	960.2	63.7	1.9296	0.1662	1.7634	197.9	
4.00	1.992	126	1115.0	93.90	1021.1	956.8	64.3	1.9183	0.1747	1.7436	173.9	
4.50	2.219	130	1116.7	97.89	1018.8	954.1	64.7	1.9095	0.1816	1.7279	157.1	
5.00	2.467	134	1118.4	101.88	1016.5	951.4	65.1	1.9008	0.1883	1.7125	142.2	

SATURATED STEAM (Continued)

PRESSURE.		TEMP. ° F.	HEAT—BRITISH THERMAL UNITS.				ENTROPY.			SP. VOL. Cu.ft.	PRES. ABS. Lbs. Sq.in.
* Gauge Pres- sure. Lbs. Sq.in.	Abs. Lbs. Sq.in.		Total.	Water.	Latent.		Total.	Liquid.	Vapor.		
	p	t	$\lambda(H)$	$q(h)$	$r(L)$	$\rho(I)$	APu^*	$\Delta\phi_e(n)(\theta)$	$\Delta\phi_v\left(\frac{r}{T}\right)\left(\frac{L}{T}\right)$	$V(v)(s)$	p
11.3	26	242.2	1161.2	210.6	950.6	875.1	75.5	0.3564	1.3542	15.72	26
12.3	27	244.4	1161.9	212.7	949.2	873.5	75.7	0.3594	1.3483	15.18	27
13.3	28	246.4	1162.6	214.8	947.8	872.0	75.8	0.3623	1.3425	14.67	28
14.3	29	248.4	1163.2	216.8	946.4	870.5	75.9	0.3652	1.3367	14.19	29
15.3	30	250.3	1163.9	218.8	945.1	869.0	76.1	0.3680	1.3311	13.74	30
17.3	32	254.1	1165.1	222.6	942.5	866.2	76.3	0.3733	1.3205	12.93	32
19.3	34	257.6	1166.3	226.2	940.1	863.4	76.7	0.3784	1.3107	12.22	34
21.3	36	261.0	1167.3	229.6	937.7	860.8	76.9	0.3832	1.3014	11.58	36
23.3	38	264.2	1168.4	232.9	935.5	858.3	77.2	0.3877	1.2925	11.01	38
25.3	40	267.3	1169.4	236.1	933.3	855.9	77.4	0.3920	1.2841	10.49	40
27.3	42	270.2	1170.3	239.1	931.2	853.6	77.6	0.3962	1.2759	10.02	42
29.3	44	273.1	1171.2	242.0	929.2	851.3	77.9	0.4002	1.2681	9.59	44
31.3	46	275.8	1172.0	244.8	927.2	849.2	78.0	0.4040	1.2607	9.20	46
33.3	48	278.5	1172.8	247.5	925.3	847.1	78.2	0.4077	1.2536	8.84	48
35.3	50	281.0	1173.6	250.1	923.5	845.0	78.5	0.4113	1.2468	8.51	50

SATURATED STEAM TABLE

37.3	52	283.5	1174.3	252.6	921.7	843.1	78.6	1.6549	0.4147	1.2402	8.20
39.3	54	285.9	1175.0	255.1	919.9	841.1	78.8	1.6519	0.4180	1.2339	7.91
41.3	56	288.2	1175.7	257.5	918.2	839.3	78.9	1.6490	0.4212	1.2278	7.65
43.3	58	290.5	1176.4	259.8	916.5	837.4	79.1	1.6460	0.4242	1.2218	7.40
45.3	60	292.7	1177.0	262.1	914.9	835.6	79.3	1.6432	0.4272	1.2160	7.17
47.3	62	294.9	1177.6	264.3	913.3	833.9	79.4	1.6406	0.4302	1.2104	6.95
49.3	64	297.0	1178.2	266.4	911.8	832.2	79.6	1.6380	0.4330	1.2050	6.75
51.3	66	299.0	1178.8	268.5	910.2	830.5	79.7	1.6355	0.4358	1.2007	6.56
53.3	68	301.0	1179.3	270.6	908.7	828.9	79.8	1.6331	0.4385	1.1946	6.38
55.3	70	302.9	1179.8	272.6	907.2	827.3	79.9	1.6307	0.4411	1.1896	6.20
57.3	72	304.8	1180.4	274.5	905.8	825.8	80.0	1.6285	0.4437	1.1848	6.04
59.3	74	306.7	1180.9	276.5	904.4	824.2	80.2	1.6263	0.4462	1.1810	5.89
61.3	76	308.5	1181.4	278.3	903.0	822.7	80.3	1.6242	0.4487	1.1755	5.74
63.3	78	310.3	1181.8	280.2	901.7	821.3	80.4	1.6221	0.4511	1.1710	5.60
65.3	80	312.0	1182.3	282.0	900.3	819.8	80.5	1.6200	0.4535	1.1665	5.47
67.3	82	313.8	1182.8	283.8	899.0	818.4	80.6	1.6180	0.4557	1.1623	5.34
69.3	84	315.4	1183.2	285.5	897.7	817.0	80.7	1.6160	0.4579	1.1581	5.22
71.3	86	317.1	1183.6	287.2	896.4	815.6	80.8	1.6141	0.4601	1.1540	5.10
73.3	88	318.7	1184.0	288.9	895.2	814.3	80.9	1.6123	0.4623	1.1500	5.00
75.5	90	320.3	1184.4	290.5	893.9	813.0	80.9	1.6105	0.4644	1.1461	4.89
77.3	92	321.8	1184.8	292.1	892.7	811.7	81.0	1.6087	0.4664	1.1423	4.79
79.3	94	323.4	1185.2	293.7	891.5	810.4	81.1	1.6069	0.4684	1.1385	4.69
81.3	96	324.9	1185.6	295.3	890.3	809.1	81.2	1.6052	0.4704	1.1348	4.60
83.3	98	326.4	1186.0	296.8	889.2	807.9	81.3	1.6036	0.4724	1.1312	4.51
85.3	100	327.8	1186.3	298.3	888.0	806.6	81.4	1.6020	0.4743	1.1277	4.429

SATURATED STEAM (Continued)

PRESSURE.		TEMP. ° F.	HEAT—BRITISH THERMAL UNITS.				ENTROPY.			PRES. ABS. Lbs. Sq.in.	
* Gauge Pres- sure. Lbs. Sq.in.	ABS. Lbs. Sq.in.		Total.	Water.	Latent.		Total.	Liquid.	Vapor.		
	p	t	$\lambda(H)$	$q(h)$	$r(L)$	$\rho(I)$	APu^*	$\Delta\phi(N)$	$\Delta\phi_v\left(\frac{r}{T}\right)\left(\frac{L}{T}\right)$	$V(v)(s)$	p
90.3	105	331.4	1187.2	302.0	885.2	803.6	81.6	1.5980	0.4789	1.1191	105
95.3	110	334.8	1188.0	305.5	882.5	800.7	81.8	1.5942	0.4834	1.1108	110
100.3	115	338.1	1188.8	309.0	879.8	797.9	81.9	1.5907	0.4877	1.1030	115
105.3	120	341.3	1189.6	312.3	877.2	795.2	82.0	1.5873	0.4919	1.0954	120
110.3	125	344.4	1190.3	315.5	874.7	792.6	82.1	1.5839	0.4959	1.0880	125
115.3	130	347.4	1191.0	318.6	872.3	790.0	82.3	1.5807	0.4998	1.0809	130
120.3	135	350.3	1191.6	321.7	869.9	787.5	82.4	1.5777	0.5035	1.0742	135
125.3	140	353.1	1192.2	324.6	867.6	785.0	82.6	1.5747	0.5072	1.0675	140
130.3	145	355.8	1192.8	327.4	865.4	782.7	82.7	1.5719	0.5107	1.0612	145
135.3	150	358.5	1193.4	330.2	863.2	780.4	82.8	1.5692	0.5142	1.0550	150
140.3	155	361.0	1194.0	332.9	861.0	778.1	82.9	1.5664	0.5175	1.0489	155
145.3	160	363.6	1194.5	335.6	858.8	775.8	83.0	1.5639	0.5208	1.0431	160
150.3	165	366.0	1195.0	338.2	856.8	773.6	83.2	1.5615	0.5239	1.0376	165
155.3	170	368.5	1195.4	340.7	854.7	771.5	83.2	1.5590	0.5269	1.0321	170
160.3	175	370.8	1195.9	343.2	852.7	769.4	83.3	1.5567	0.5299	1.0268	175

165.3	180	373.1	1196.4	345.6	850.8	767.4	83.4	1.5543	0.5328	1.0215	2.533	180
170.3	185	375.4	1196.8	348.0	848.8	765.4	83.4	1.5520	0.5356	1.0164	2.468	185
175.3	190	377.6	1197.3	350.4	846.9	763.4	83.5	1.5498	0.5384	1.0114	2.406	190
180.3	195	379.8	1197.7	352.7	845.0	761.4	83.6	1.5476	0.5410	1.0066	2.346	195
185.3	200	381.9	1198.1	354.9	843.2	759.5	83.7	1.5456	0.5437	1.0019	2.290	200
235.3	250	401.1	1201.5	375.2	826.3	742.0	84.3	1.5276	0.5676	0.9600	1.850	250
285.3	300	417.5	1204.1	392.7	811.3	726.8	84.5	1.5129	0.5878	0.9251	1.551	300
385.3	400	444.8	1208	422	786.0	701	85	1.489	0.621	0.868	1.17	400
485.3	500	467.3	1210	448	762	678	84	1.470	0.648	0.822	0.93	500
*985.3	1000	545	1200	535	665	587	78	1.39	0.73	0.66	0.4	1000
*	2000	640	?	?	490	430	60	?	?	0.45	0.2	2000
*Crit.	3200	706	?	?	0	0	0	?	?	?	0.05	3200

$$\frac{320.8}{370.8} = 130.0$$

PROPERTIES OF ONE POUND OF SUPERHEATED STEAM

[Condensed from Marks and Davis's STEAM TABLES AND DIAGRAMS, 1909, by permission of the publishers, Longmans, Green & Co.]

Sp.V. = specific volume in cu.ft.; ΔQ = B.t.u. total heat above 32° F.; $\Delta\phi$ = total entropy above 32° F.

Absolute Pressure. Lbs. Sq.in. Sat. Temp. ° F.		Degrees of Superheat.						
		0	50	100	150	200	250	300
15 (213)	Sp. V.	26.27	28.40	30.46	32.50	34.53	36.56	38.58
	ΔQ	1150.7	1174.2	1197.6	1221.0	1244.4	1267.7	1291.1
	$\Delta\phi$	1.7549	1.7886	1.8199	1.8492	1.8768	1.9029	1.9276
50 (281)	Sp. V.	8.51	9.19	9.84	10.48	11.11	11.74	12.36
	ΔQ	1173.6	1198.8	1223.4	1247.7	1271.8	1295.8	1319.7
	$\Delta\phi$	1.6581	1.6909	1.7211	1.7491	1.7755	1.8002	1.8237
100 (327.8)	Sp. V.	4.43	4.79	5.14	5.47	5.80	6.12	6.44
	ΔQ	1186.3	1213.8	1239.7	1264.7	1289.4	1313.6	1337.8
	$\Delta\phi$	1.6020	1.6358	1.6658	1.6933	1.7188	1.7428	1.7656
110 (334.8)	Sp. V.	4.05	4.38	4.70	5.01	5.31	5.61	5.90
	ΔQ	1188.0	1215.9	1242.0	1267.1	1291.9	1316.2	1340.4
	$\Delta\phi$	1.5942	1.6282	1.6583	1.6857	1.7110	1.7350	1.7576
120 (341.3)	Sp. V.	3.73	4.04	4.33	4.62	4.89	5.17	5.44
	ΔQ	1189.6	1217.9	1244.1	1269.3	1294.1	1318.4	1342.7
	$\Delta\phi$	1.5873	1.6216	1.6517	1.6789	1.7041	1.7280	1.7505
130 (347.4)	Sp. V.	3.45	3.74	4.02	4.28	4.54	4.80	5.05
	ΔQ	1191.0	1219.7	1246.1	1271.4	1296.2	1320.6	1344.9
	$\Delta\phi$	1.5807	1.6153	1.6453	1.6724	1.6976	1.7213	1.7437
140 (353.1)	Sp. V.	3.22	3.49	3.75	4.00	4.24	4.48	4.71
	ΔQ	1192.2	1221.4	1248.0	1273.3	1298.2	1322.6	1346.9
	$\Delta\phi$	1.5747	1.6096	1.6395	1.6666	1.6916	1.7152	1.7376
150 (358.5)	Sp. V.	3.01	3.27	3.51	3.75	3.97	4.19	4.41
	ΔQ	1193.4	1223.0	1249.6	1275.1	1300.0	1324.5	1348.8
	$\Delta\phi$	1.5692	1.6043	1.6343	1.6612	1.6862	1.7097	1.7320

PROPERTIES OF ONE POUND OF SUPERHEATED STEAM

(Continued)

Absolute Pressure. Lbs. Sq.in. Sat. Temp. ° F.		Degrees of Superheat.						
		0	50	100	150	200	250	300
160 (363.6)	Sp. V.	2.83	3.07	3.30	3.53	3.74	3.95	4.15
	ΔQ	1194.5	1224.5	1251.3	1276.8	1301.7	1326.2	1350.6
	$\Delta\phi$	1.5693	1.5993	1.6292	1.6561	1.6810	1.7043	1.7266
170 (368.5)	Sp. V.	2.68	2.91	3.12	3.34	3.54	3.73	3.92
	ΔQ	1195.4	1225.9	1252.8	1278.4	1303.3	1327.9	1352.3
	$\Delta\phi$	1.5590	1.5947	1.6246	1.6513	1.6762	1.6994	1.7217
180 (373.1)	Sp. V.	2.53	2.75	2.96	3.16	3.35	3.54	3.72
	ΔQ	1196.4	1227.2	1254.3	1279.9	1304.8	1329.5	1353.9
	$\Delta\phi$	1.5543	1.5904	1.6201	1.6468	1.6716	1.6948	1.7169
190 (377.6)	Sp. V.	2.41	2.62	2.81	3.00	3.19	3.37	3.55
	ΔQ	1197.3	1228.6	1255.7	1281.3	1306.3	1330.9	1355.5
	$\Delta\phi$	1.5498	1.5862	1.6159	1.6425	1.6627	1.6904	1.7124
200 (381.9)	Sp. V.	2.29	2.49	2.68	2.86	3.04	3.21	3.38
	ΔQ	1198.1	1229.8	1257.1	1282.6	1307.7	1332.4	1357.0
	$\Delta\phi$	1.5456	1.5823	1.6120	1.6385	1.6632	1.6862	1.7082
300 (417.5)	Sp. V.	1.55	1.69	1.83	1.96	2.09	2.21	2.33
	ΔQ	1204.1	1240.3	1268.2	1294.0	1319.3	1344.3	1369.2
	$\Delta\phi$	1.5129	1.5530	1.5824	1.6082	1.6323	1.6550	1.6765
500 (467.3)	Sp. V.	0.93	1.03	1.11	1.22	1.31	1.39	1.47
	ΔQ	1210.0	1256	1285	1311	1337	1362	1388
	$\Delta\phi$	1.470	1.519	1.548	1.573	1.597	1.619	1.640

INDEX

	PAGE
Absolute pressures	41
Absolute temperature scale	12
Action of steam, in cylinder	24
on impulse blades of steam turbine	234-236
Adiabatic expansion	58
Advance angle	167
Advantages of condensing	251, 252
Advantages, relative, of contact and non-contact condensers	274, 275
Air, excess, combustion	286
Advantages and disadvantages of	311
Analogy, hydraulic	26
Analyses of coal (see fuels)	299-301
Purchase of coal on analysis	302
Angle of advance	167
Ash in coal	300
Atmospheric line on indicator diagram	119
Atoms	278
Avogadro's Law	281
Babcock & Wilcox superheater	367
" " " water-tube boiler	352-355
Balanced slide valves	184
Barometer, conversion of readings from inches mercury to pounds per square inch	255, 256
Barometric Condenser	261-266
Baumé scale to express gravity	303
Bearings	111, 112
Bilgram diagram	168-182
Angularity of connecting rod	179
Diagram for both cylinder ends	177
Exhaust and compression	175-177
Indicator diagram from	180-183
Piston positions	177-182
Blades, impulse, action of steam on, in impulse turbine	234-236

	PAGE
Boiler-feed pumps and other auxiliaries.....	382-390
Boiler, generation of steam in.....	38, 39
Boilers, steam.....	305-374
Circulation in.....	341, 342
Classification according to—	
(1) form; (2) location of furnace; (3) use; (4) direction of principal axis; (5) relative positions of water and hot gases.....	305, 306
Draft apparatus.....	370-373
Chimneys or stacks.....	370-372
Mechanical draft.....	372, 373
Effects of soot and scale.....	364, 365
Efficiencies.....	363, 364
Functions of parts.....	306-308
Furnaces and combustion.....	308-311
Hand firing.....	311-315
Mechanical grates.....	315, 316
Mechanical stokers.....	317-335
Rate of combustion.....	335-337
Rating.....	358-362
Boiler horse-power.....	359
Equivalent evaporation.....	361
Scale.....	365, 366
Prevention of.....	366
Smoke and its prevention.....	316, 317
Strength and safety.....	337-341
Superheaters—	
Built in.....	366, 367
Separately fired.....	366, 367
Babcock & Wilcox.....	367
Foster.....	369, 370
Heine.....	367, 368
Types of boilers.....	342-359
Babcock & Wilcox, water tube.....	352-355
Continental.....	346-348
Externally fired, return tubular.....	349-352
Heine water-tube.....	355, 356
Internally fired, tubular.....	342-345
Locomotive.....	346
Scotch marine.....	348, 349
Sterling water-tube.....	356-358
Vertical fire tube.....	343-345
Wickes vertical water-tube.....	358, 359

	PAGE
British Thermal unit.....	3, 13
Buildings, heating of, by exhaust steam.....	376, 377
Built-in superheaters.....	366, 367
Calorific value of coals—	
Dulong's formula.....	301, 302
Fuel Calorimeter.....	302
Calorific value of, petroleum oils.....	303, 304
Calorimeter, fuel.....	302
Carbon, combustion of.....	279
CO, combustion to.....	279-282
CO ₂ combustion to.....	282, 283
CO and CO ₂ , conditions determining formation of.....	284-286
CO to CO ₂ , combustion of.....	283, 284
complete combustion of.....	308-310
flue gases from combustion of.....	286, 287
Card factors and conventional diagram.....	125-128
Centigrade scale.....	10, 11, 12
Chain grate stokers.....	318-322
Chart—	
Mollier, for steam.....	230
temperature-entropy, for steam.....	62-65
Chimneys or stacks.....	370-372
Circulation in boilers.....	341-342
Classification of boilers, according to—	
(1) form; (2) location of furnace; (3) use; (4) direction of principal axis; (5) relative position of water and hot gases.....	305-374
Classification of steam engines.....	92, 93
Clearance—steam engine—	
mechanical and volumetric.....	84, 85
Clearance volume determined from diagram.....	131, 132
Closed and open feed-water heaters.....	377-380
Coal-fuels.....	297-299
Analyses of—proximate and ultimate.....	299-301
Purchase of, on analysis.....	302
Coefficient, excess in combustion.....	286
Combined indicator diagrams.....	155-158
Combined type turbine.....	247
Combustion and furnaces; steam boilers.....	308-311
Combustion.....	277-295
Definitions—Compounds, elements, heat or calorific value, atoms, molecules, etc.....	277-279

Combustion—	
Combustion of—	
Carbon.....	279
Hydrocarbons.....	289, 290
Hydrogen.....	287-289
Calorific value of.....	290
Mixtures.....	290, 291
Sulphur.....	290
Combustion to—	
CO.....	279-282
CO ₂	282, 283
CO to CO ₂	283, 284
Conditions determining formation of CO and CO ₂	284-286
Excess Air and excess coefficient.....	286
Flue gases from combustion of carbon.....	286, 287
Rate of, in boiler furnaces.....	335-337
Temperature of combustion.....	291-294
Theoretical temperature.....	292
Commercial fuels—solid, liquid and gaseous.....	296, 297
Complete expansion cycle.....	55-58, 72
Complete $T\phi$ -chart for steam.....	68-70
Compound engine.....	149-151
Compounding.....	141-158
Combined indicator diagram.....	155-158
Compounding.....	144-149
Cylinder ratios.....	151-153
Gain by expansion.....	141-144
Indicator diagrams and mean pressures.....	153-155
The compound engine.....	149-151
Compounds—combustion.....	277-279
Compression and exhaust—Bilgram diagram.....	175-177
Condensation, cylinder, methods of decreasing.....	89-92
Condensation, initial.....	81, 82
determination of.....	86-89
Condensers and related apparatus.....	251-276
Advantages of condensing.....	251, 252
Conversion of readings from inches of mercury to lbs. per square inch.....	255, 256
Cooling towers.....	275, 276
Measurement of vacuum.....	252-255
Principle of.....	256-258
Types of—	
Contact.....	258-268

Condensers (continued)—	
Contact—	
Barometric.....	261-266
Jet, Parallel flow.....	259, 260
Siphon.....	266
Westinghouse—Leblanc.....	267, 268
Non-contact	268-271
Surface.....	268-270
Two-pass or double flow	270-271
Relative advantages.....	274, 275
Water required by contact condensers.....	271-273
Water required by non-contact condensers.....	273, 274
Condensing, advantages of.....	251, 252
Condensing plants.....	23
Conditions determining formation of CO and CO ₂	284-286
Connecting rod.....	109, 110
Angularity of.....	179
Conservation of Energy, law of.....	2
Conservation of Matter, law of.....	1
Constant-quality lines on $T\phi$ -chart.....	66, 67
Constant volume lines. on $T\phi$ -chart.....	68
Constant speed governing.....	215, 216
Contact condensers.....	258-268
Continental type boiler.....	346-348
Conventional diagram and card factors.....	125-128
Conversion of barometric readings, from inchs mercury to pounds	
per square inch.....	255, 256
Cooling towers.....	275, 276
Corliss and other high-efficiency engines.....	196-212
Locomobile type.....	210-212
Non-detaching Corliss gears.....	201-205
Poppet valves.....	205-208
Trip-cut-off Corliss.....	196-201
Unafrow engine.....	208-210
Corliss engine, trip-cut-off.....	196-201
Corliss gears, non-detaching.....	201-205
Crank end of engines.....	98
Cross-head and guides.....	107, 108
Cushion steam and cylinder feed.....	85, 86
Cut-off governing.....	215
Cut-off ratio.....	128
Cycle, area on $T\phi$ -chart representative of work.....	73
Complete expansion.....	55-58, 72

	PAGE
Cycle, incomplete expansion	58-60, 74, 75
Modifications for wet and superheated steam	73, 74
Of events in simple steam power plant	22
Theoretical, of steam turbine	225-228
Cycles, desirability of various, in engines	55
Cylinder, action of steam in	24
Condensation, methods of decreasing	89-92
Efficiency	139
Feed and cushion steam	85, 86
Ratios	151-153
Cylinder and steam chest	101, 102
Decreasing cylinder condensation	89-92
De Laval impulse turbine	236-238
Density, specific, of dry saturated steam	38
Description and method of operation of D-slide valve	159-165
Design of nozzle, steam turbine	228-234
Determination of clearance volume from diagram	131, 132
Determination of I.h.p.	120-124
Developed horse-power	137
Developed thermal efficiency	138
D-slide valve	159-195
Angle of advance	167
Angularity of connecting rod	179
Bilgram diagram	169
Description and method of operation	159-165
Diagram for both cylinder ends	177
Exhaust and compression	175
Exhaust lap	168
Indicator diagram from Bilgram diagram	180
Lead	166, 167
Limitations of D-slide valve	183-185
Piston positions	177
Reversing engines	185-187
Steam lap—outside lap	165, 166
Valve setting	187-195
D-slide valve engine, simple	96-98
Diagram, Bilgram, for both cylinder ends	177
Bilgram, indicator diagram from	180-183
Indicator	24
Indicator and mean pressures for compound engines	153-155
combined	155-158
Indicator, conventional and card factors	125-128

	PAGE
Diagram, water rate.....	86, 132-136
Diagrams from real engine.....	192, 193
Double acting engines.....	55
Double-flow condenser.....	270
Downdraft furnace.....	315
Draft apparatus.....	370-373
Chimneys or stacks.....	370-372
Mechanical draft.....	372, 373
Dry-air pump.....	264
Dry-saturated steam, total heat of.....	33
Specific density of.....	38
Specific volume of.....	36-38
Dry-vacuum pump.....	264
Dulong's formula—combustion.....	301, 302
Duplex steam pump.....	383, 384
Eccentric.....	160-165
Economy of turbines.....	247-249
Effective pressure, mean, methods of varying.....	215
Efficiency.....	52, 53
Cylinder.....	139
Developed thermal.....	138
Effect of temperature range on.....	75
Indicated thermal.....	138
Mechanical and thermal.....	137-140
Of boilers.....	363, 364
Relative.....	139
Elements—combustion.....	277
Energy—	
Conservation of energy, law of.....	2
Heat.....	2
Mechanical.....	2
Units of.....	3
Engine—	
Application of theory for an ideal to a real.....	54, 55
Compound, triple, quadruple, quintuple.....	148
Receiver type.....	149
Tandem and cross-compound.....	151
Woolf type.....	149
Desirability of various cycles.....	55
Double acting.....	55
Efficiency.....	52, 53
Heat quantities involved.....	50-52

Engine (continued)—

Ideal steam.....	43-60
Operation of	45, 42
Operation of the real steam.....	77-80
Reversing	185-187
Steam—	
Classification—	
1) On basis of rotative speed; (2) Ratio of stroke to diameter; (3) Valve gear; (4) Position of longitudinal axis; (5) Number of cylinders; (6) Cylinder arrangement; (7) Use.....	92, 93
Clearance, volumetric and mechanical.....	84, 85
Crosshead and guides.....	107, 108
Cushion steam and cylinder feed.....	85, 86
Diagram water rate.....	86
Cylinder and steam chest.....	101, 102
Determination of initial condensation.....	86-89
Initial condensation.....	81
Losses, in real installations.....	80-84
Methods of decreasing cylinder condensation...	89-92
Nomenclature.....	98
Principal parts	98-114
Bearings	111, 112
Connecting rod.....	109, 110
Crosshead and guides.....	107, 108
Cylinder and steam chest.....	101, 102
Flywheels	112, 113
Frame.....	99, 100
Piston	102-106
Piston rod and tail rod.....	106, 107
Shaft.....	110, 111
Re-evaporation in	83, 84
Rotative and piston speed.....	93-96
Simple D-slide valve.....	96-98
Throttling or wire-drawing.....	82, 83
Work done by.....	46-60
Engines, Corliss and other high efficiency.....	185-187
Locomobile type.....	210-212
Non-detaching Corliss gears.....	201-205
Poppet valves.....	205-208
Trip-cut-off Corliss.....	196-201
Unafrow.....	208-210

	PAGE
Entropy diagram	61-71
of liquid, vaporization, and dry saturated steam	61-63
$T\phi$ -chart for steam	62-65
Complete	68-70
Constant quality lines	66, 67
Diagram for a real engine	136
Heat from	68
Quality from	65-68
Saturation curve	63
Superheating lines	63, 64
Volume from	68
Water line	63
Entropy, diagrams of steam cycles	72-76
Equivalent evaporation, boilers	361
Excess air—combustion	286
Advantages and disadvantages	311
Excess coefficient	286
Exhaust and compression—Bilgram diagram	175-177
Exhaust lap	166, 168
Exhaust steam, utilization of, for heating buildings	376, 377
Expansion, adiabatic	58
Cycle, the complete	55-58, 72
the incomplete	58-60
Gain by, in compounding	151-144
Ratio of, apparent and real	128-130
External latent heat of vaporization	31
Externally fired, return tubular boiler	349-352
Fahrenheit scale	11, 12
Feed-water heating	377
Open and closed heaters	377-380
Firing boilers by hand	311-315
Fixed carbon in coal	300
Flywheel	97, 98, 112, 113
Regulation	213, 214
Flue gases from combustion of carbon	286, 287
Foot-pound, definition	3
Forward stroke of engines	98
Foster superheater	369, 370
Frames of engines	99, 100
Front end of engines	98
Fuel calorimeter	302
Fuels	296-304

Fuels (continued)—	
Commercial—	
Solid, liquid, gaseous	296, 297
Coal	297-299
Analyses	299-301
Calorific value of—	
Dulong's formula	301, 302
Fuel Calorimeter	302
Petroleum	302
Baumé scale to express gravity	303
Calorific values	303, 304
Purchase of coal on analysis	302
Functions of boiler parts	306-308
Furnaces—and combustion	308-311
—Updraft and downdraft	315
Gases, and vapors, steam	27
—Flue, from combustion of carbon	286, 287
Gaseous fuels	296, 297
Gauge pressure	39-41
Gearing and staging—turbines	238-243
Gears, Corliss, non-detaching	201-205
Generation of steam in real steam boiler	38, 39
Generation of steam or water vapor	28
Governing—throttle and cut-off	215
Coefficient of regulation	216
Constant speed	215, 216
Governor	97, 98
Regulation	214, 215
Governors—	
Pendulum	217
Rites inertia	218-220
Shaft	217, 218
Grates, mechanical	315, 316
Gridiron valve	185
Guides and crosshead	107, 108
Hand firing—steam boilers	311-315
Heat	9
Absorption, reversal of process	38
Energy	2
Unit of	13
From $T\phi$ -chart	68

Heat (continued)—	
Latent, of vaporization.....	30, 32
Internal and external.....	30, 31
Of liquid, q or h.....	31, 32
Of superheat.....	34, 35
Quantities in rectangular cycle.....	50-52
Quantity of.....	16
Specific.....	14
Total, of dry saturated steam.....	33
Of superheated steam.....	36
Of wet steam.....	33, 34
Value of elements and compounds.....	277-279
Heat, waste—in steam plant.....	375-381
Feed-water heating.....	377
Open and closed heaters.....	377-380
Utilization of exhaust for heating buildings.....	376, 377
Heaters, feed-water, open and closed.....	377-380
Heine superheater.....	367, 368
Heine water-tube boiler.....	355, 356
Horizontal, return, tubular boiler.....	306-308
Horse-power.....	17
Developed.....	137
Hour, definition.....	18
Of steam boilers.....	359
Hydraulic analogy.....	26
Hydrocarbons, combustion of.....	289, 290, 310
Calorific value of.....	290
Hydrogen, combustion of.....	287-289
I.h.p.—determination of.....	120-124
Impulse steam turbine.....	221-225
De Laval type.....	236-238
Inclined stokers.....	322-325
Incomplete expansion cycle.....	58-60, 74, 75
Indicated thermal efficiency.....	138
Indicator.....	115
Indicator diagram.....	24, 115-140
Atmospheric line.....	119
Conventional and card factors.....	125-129
Cut-off ratio.....	128
Determination of clearance volume from diagram.....	131, 132
Determination of I.h.p.....	120-124
Diagram factor or card factor.....	126-129

Indicator diagram (continued)—	
From Bilgram diagram	180-183
Mean effective pressure	122
Ratio of expansion	128-131
Reducing mechanism	118
Scale of spring	118
The planimeter	123
Indicator diagrams and mean pressures for compound engines	153-155
Combined	155-158
Indicator diagrams from real engine	192, 193
Injector, steam	384-386
Inertia governor, Rites	218-220
Initial condensation	81, 82
Determination of	86-89
Inside lap, negative	168
Internal latent heat of vaporization	30
Internally fired, tubular boilers	342-345
Jet condensers	259, 260
Joule's equivalent	14
Joule, the	3
Kinetic mechanical energy	8
Lap angle	166
Lap, steam	165, 166
Negative inside	168
Outside and exhaust	166, 168
Latent heat of vaporization	30, 32
Internal and external	30, 31
Lead	166, 167
Leblanc—Westinghouse condenser	267, 268
Liquid fuels	296, 297
Liquid, heat of, q or h	31, 32
Entropy of	61
Limitations of D-slide valve	183-185
Balanced slide valves	184
Gridiron valve	185
Piston valve	184
Riding cut-off valves	185
Locomobile type of high efficiency engines	210-212
Locomotive type boiler	346
Low-pressure or exhaust steam turbines	249

	PAGE
Matter.....	1
Law of conservation of matter.....	1
Units of matter.....	3
Mean effective pressure.....	122
Methods of varying.....	215
Mean pressures and indicator diagrams for compound engines.	153-155
Measurement of temperature.....	10
Measurement of vacuums.....	252-255
Mechanical and thermal efficiencies.....	137-140
Mechanical clearance, steam engine.....	84, 85
Mechanical draft.....	372, 373
Mechanical energy.....	2, 3, 7
Potential and kinetic.....	7, 8
Mechanical grates.....	315, 316
Mechanical stokers.....	317-335
Mercury readings, conversion to pounds per square inch.....	255, 256
Mercury thermometers.....	10-12
Method of operation and description of D-slide valve.....	159-165
Mixtures, combustion of.....	290, 291
Moisture in coal.....	299
Molecular activity.....	9
Molecules.....	278
Natural draft, chimneys.....	370
Negative inside lap.....	168
Non-condensing plants.....	23
Non-contact condensers.....	263-271
Surface (Wheeler).....	268-270
Non-detaching Corliss gears.....	201-205
Nozzle design, steam turbine.....	228-234
Oil firing.....	333-335
Open and closed feed-water heaters.....	377-380
Operation of simplified steam engine.....	45, 46
Operation of real steam engine.....	77-80
Outside steam lap.....	166
Outstroke of engine.....	98
Parallel-flow condenser.....	259-261
Parson's type turbine.....	246
Pendulum governors.....	217
Petroleum.....	302
Baumé scale to express gravity of.....	303
Calorific values.....	303, 304

	PAGE
Piping, steam	390
Piston, engine	102-106
Piston positions for Bilgram diagram	177-182
Piston rod and tail rod	106, 107
Piston speeds of steam engines	93-96
Piston valve	184
Planimeter	123
Plant, steam power	20
Plants, condensing, non-condensing	23
Poppet valves	205-208
Positions of piston for Bilgram diagram	177-182
Potential mechanical energy	7
Powdered coal stokers	333
Power and work	17
Power, unit of, horse power	17
Pressure, absolute	41
Gauge	39-41
Mean effective	122
Methods of varying	215
Pressures, mean, and indicator diagrams for compound engines	153-155
Prevention of smoke	316, 317
Prime-mover	20
Principal parts of engines	98-114
Principle of condenser	256-258
Properties of steam	27
Proximate analysis of coal	299
Pump, dry air or dry vacuum	264
Vacuum	259
Pumps, boiler feed	382-384
Purchase of coal on analysis	302
Quality from $T\phi$ -chart	65-68
Constant, lines	66, 67
Quantity of heat	16
Rate, diagram water	86, 132-136
Rate of combustion in boiler furnaces	335-337
Rating of steam boiler	358-362
Ratio, cut-off	128
Ratio of expansion—apparent and real	128-130
Ratios, cylinder	151-153
Reaction type turbine	243-247
Receiver engine	149

	PAGE
Recovery of waste heat.....	375-381
Reducing mechanism.....	118
Re-evaporation.....	83
Regulation.....	213-220
Coefficient of governor.....	216
Constant speed governing.....	215, 216
Governors—	
Pendulum.....	217
Rites inertia.....	218-220
Shaft.....	217, 218
Kinds—flywheel and governor.....	213-215
Methods of varying mean effective pressure—Throt- tling and cut-off.....	215
Relative advantages of contact and non-contact condensers..	274, 275
Relative efficiency.....	139
Return tubular boilers, horizontal.....	306-308, 349-352
Reversal of process of heat absorption.....	38
Reversing engines.....	185-187
Riding cut-off valve.....	185
Rites inertia governor.....	218-220
Rotative speeds of steam engines.....	93-96
Safety and strength of boilers.....	337-341
Saturated steam, dry, specific volume of.....	36-38
Saturated vapor.....	31
Saturation curve, temperature entropy chart for steam.....	63
for compound engine cards.....	156
Scale.....	365, 366
Prevention of.....	366
Scale of spring, indicator.....	118
Scotch marine type boiler.....	348, 349
Separately fired superheaters.....	366, 367
Separators.....	386-388
Setting, valve.....	187-195
Shaft governors.....	217, 218
Shaft of engine.....	110, 111
Simple D-slide valve engine.....	96-98
Siphon condensers.....	266
Slide valves.....	184
Balanced.....	184
Gridiron valve.....	185
Piston valve.....	184
Riding cut-off valve.....	185

	PAGE
Smoke and its prevention.....	316, 317
Solid fuels.....	296, 297
Soot and scale, effects of, in boilers.....	364, 365
Specific density of dry, saturated steam.....	38
Specific heat.....	14
Specific volume of dry saturated steam.....	36-38
Speeds, rotative and piston, of steam engines.....	93-96
Spring, scale of, indicator.....	118
Stacks or chimneys.....	370-372
Staging and gearing, steam turbines.....	238-243
Steam, action in cylinder.....	24
Action of, on impulse blades of turbine.....	234-236
Boiler, generation of steam in.....	38, 39
Cushion, and cylinder feed.....	85, 86
Diagram water rate.....	86
Cycles, $T\phi$ -diagrams of,.....	72-76
Steam engine the ideal.....	43-60
Bearings.....	111, 112
Classification.....	92, 93
Connecting rod.....	109, 110
Crosshead and guides.....	107, 108
Cylinder and steam chest.....	101, 102
Determination of initial condensation.....	86-89
Flywheel and governor.....	97, 98
Flywheels.....	112, 113
Frame.....	99, 100
Losses in real installations.....	80-84
The real.....	77-114
Initial condensation.....	81
Re-evaporation.....	83, 84
Throttling.....	82
Wire-drawing.....	82, 83
Methods of decreasing cylinder condensation.....	89-92
Nomenclature of.....	98
Operation of,.....	77-80
Piston.....	102-106
Piston rod and tail rod.....	106, 107
Principal parts.....	98-114
Rotative and piston speeds.....	93-96
Simple D-slide valve.....	96-98
Steam, entropy of dry saturated.....	61, 62
Generation of.....	28-39
Heat of superheat.....	34-35

	PAGE
Steam, lap, D-slide valve.....	165, 166
Modification of $T\phi$ -chart for wet and superheated.....	73, 74
Properties of.....	27
Specific density of dry saturated.....	38
Specific volume of dry saturated.....	36-38
Temperature-entropy chart for.....	62-71
$T\phi$ -chart complete.....	68-70
Total heat of dry saturated.....	33
Total heat of wet.....	33, 34
Vapors and gases.....	27
Wet, effect of.....	53
Steam injector.....	384
Steam piping.....	390
Steam power plant.....	20-22
Steam trap.....	388
Steam turbine (see Turbine).....	
Stephenson link gear.....	186
Sterling water-tube boiler.....	356-358
Stokers, mechanical.....	317-313
Chain grate.....	318
Inclined, overfeed.....	323-327
Powdered coal.....	333
Sprinkler.....	318
Underfeed.....	327-333
Strength and safety of boilers.....	337-341
Sulphur, combustion of.....	290
Sulphur in coal.....	301
Superheat, heat of.....	34, 35
total heat of.....	36
Superheaters—	
Built in.....	366, 367
Separately fired.....	366, 367
Babcock and Wilcox.....	367
Foster.....	369, 370
Heine.....	367, 368
Superheating.....	31
Lines, on temperature-entropy chart for steam..	63, 64
Surface condensers.....	268, 269
Tail rod and piston rod of engine.....	106, 107
Temperature.....	9
Measurement of.....	10
Pressure relations.....	29

	PAGE
Temperature of combustion.....	291-294
Temperature rise.....	293
Theoretical.....	292
Temperature-entropy chart for steam.....	62-71
Complete chart.....	68-70
Heat from.....	68
Quality from.....	65-68
Volume from.....	68
$T\phi$ -diagram for a real engine.....	136
$T\phi$ -diagrams of steam cycles.....	72-76
Complete expansion cycle.....	72
Area of cycle representative of work.....	73
Modifications for wet and superheated steam.....	73
Temperature range, effect on efficiency.....	75
Temperatures of vaporization.....	29
Theoretical cycle of steam turbine.....	225-228
Thermal and mechanical efficiency.....	137-140
Developed thermal efficiency.....	138
Indicated thermal efficiency.....	138
Thermometers, mercury.....	10-12
Throttle governing.....	215
Throttling or wire-drawing.....	82
Towers, cooling.....	275, 276
Traps, steam.....	388, 389
Trip-cut-off Corliss engine.....	196-201
Triple expansion.....	148
Tubular boiler, horizontal return.....	306-308
Turbine, steam.....	221-250
Action of steam on impulse blades.....	234-236
Combined type.....	247
De Laval impulse type.....	236-238
Economy of.....	247-249
Gearing and staging.....	238-243
Impulse.....	221-225
Nozzle design.....	228-234
Reaction type.....	243-247
Theoretical cycle.....	225-228
Types of boilers.....	342-359
Babcock & Wilcox, water-tube.....	352-355
Continental.....	346-348
Externally fired, return tubular.....	349-352
Heine water-tube.....	355, 356
Internally fired, tubular.....	342-345

	PAGE
Types of boilers (continued)—	
Locomotive.....	346
Scotch marine.....	348, 349
Sterling water-tube.....	356-358
Wickes vertical water-tube.....	358, 359
Types of condensers—	
Contact.....	258-268
Barometric.....	261-266
Jet, parallel flow type.....	259, 260
Siphon.....	266
Westinghouse-Leblanc.....	267, 268
Non-contact—	
Surface.....	268-270
Two-pass or double flow.....	270, 271
Ultimate analysis of coal.....	299-301
Una-flow engine.....	208-210
Underfeed stokers.....	325-333
Unit of heat energy.....	13
Units of matter, energy and work.....	3
Updraft furnace.....	315
Utilization of exhaust steam for heating buildings.....	376, 377
Vacuum.....	252-255
Measurement of.....	253, 254
Pump.....	259
Valve, D-slide—(see D-slide valve).....	159-195
Setting.....	187-195
Valves.....	159-195, 205-208
Balanced slide.....	184
Gridiron.....	185
Piston.....	184
Poppet.....	205-208
Riding cut-off.....	185
Vapor, saturated.....	31
Pressure-temperature relations; saturated water vapor....	29
Water or steam, generation of.....	28
Vaporization, entropy of.....	61
Latent heat of.....	30, 32
Internal and external.....	30, 31
Temperatures of.....	29
Vapors and gases.....	27
Volatile matter in coal.....	299

	PAGE
Volume, clearance, determined from diagram	131, 132
Constant, line	68
From $T\phi$ -chart	68
Volumetric clearance, steam engine	84, 85
Waste heat, in steam plant	375, 376
Recovery of	375-381
Water line, temperature entropy chart for steam	63
Water rate, diagram, steam engine	86, 132-136
Water required by contact condensers	271-273
Water-tube boilers	352-359
Water vapor or steam, generation of	28
Water vapor, saturated, pressure-temperature relations	29
Weight of water required by non-contact condensers	273, 274
Westinghouse-Leblanc condenser	267, 268
Westinghouse-Parsons turbine	245
Wet and superheated steam; modifications of $T\phi$ -chart for	73, 74
Wet steam, total heat of	33, 34
Wickes vertical water-tube boiler	358, 359
Wire-drawing or throttling	82
Woolf type engine	149
Work	3, 17
Area of cycle on $T\phi$ -diagram representative of work	73
Done by the engine	46-50
Unit of	3

Jan 1 X
200 net

RETURN
TO →

ON THE LAST DATE
CIRCULATION DEPARTMENT

202 Main Library

LOAN PERIOD 1

2

3

HOME USE

4

5

6

ALL BOOKS MAY BE RECALLED AFTER 7 DAYS

RENEWALS AND RECHARGES MAY BE MADE 4 DAYS PRIOR TO DUE DATE.
LOAN PERIODS ARE 1-MONTH, 3-MONTHS, AND 1-YEAR.

RENEWALS CALL (415) 642-3405

DUE AS STAMPED BELOW

AUTO DISC JAN 25 '90

FORM NO. DD6, 60m, 1/83

UNIVERSITY OF CALIFORNIA, BERKELEY
BERKELEY, CA 94720

YB 51990

GENERAL LIBRARY - U.C. BERKELEY



8000860225

TJ 342913
275
1456

Hirshfeld

UNIVERSITY OF CALIFORNIA LIBRARY

