

From the collection of the

z n m
Preinger
Library
t p

San Francisco, California
2008

ST. NICHOLAS:

AN

ILLUSTRATED MAGAZINE

FOR YOUNG FOLKS.

CONDUCTED BY

MARY MAPES DODGE.

VOLUME XXXII.

PART II., MAY, 1905, TO OCTOBER, 1905.

THE CENTURY CO., NEW YORK
MACMILLAN AND CO., LONDON.

52271
Ref.

Copyright, 1905, by THE CENTURY CO.

THE DE VINNE PRESS.

ST. NICHOLAS:

VOLUME XXXII.

PART II.

SIX MONTHS—MAY, 1905, TO OCTOBER, 1905.

CONTENTS OF PART II. VOLUME XXXII.

AFTER BURGOYNE'S SURRENDER. (Illustrated)	130
AMBIDEXTEROUS ARTIST, THE. Picture, drawn by E. W. Kemble	1122
"AMONG THOSE PRESENT." Pictures	795
ANIMAL PETS ON SHIPBOARD. (Illustrated)	832
APPLES AND ACHES. Verse	E. W. Sturdy 816
ARCHITECTURE, A LITTLE TALK ABOUT. (Illustrated)	Charles Love Benjamin 997
AUGUST MORNING, AN. Picture, drawn by John Bolles	Lucia Ames Mead 985
AUTUMN — AND SPRINGTIME. Picture, drawn by Charles C. Curtan	878
BABY MOON, THE. Verse	1072
BAT, THE. (Illustrated)	Anna H. Branch 1093
BEARS, TWO FUNNY FRENCH. (Illustrated by the Author)	H. P. 604
BEDTIME PICTURE-BOOK, THE. Picture, from a painting by Madame Elisa Koch	Meredith Nugent 602
BEES AS DISPATCH-BEARERS. (Illustrated by the Author)	750
BIRTHDAY OF VIRGINIA, THE. (Illustrated by W. L. Jacobs)	James C. Beard 920
"BISMARCK": A GREAT DAN. (Illustrated from photographs)	Empeigh Merwin 583
BLUEBIRD, THE. (Illustrated from photographs by the Author)	A. W. Dimock 740
BOBBY IS GOING TO A PARTY. Picture, drawn by H. G. Wall	Silas A. Lottridge 610
BOY THAT BLOWS THE BUGLE, THE. Verse. (Illustrated by Katharine N. Richardson)	993
BROOKLYN BRIDGE, A JUNE EVENING ON THE. Picture, drawn by A. B. Doggett	Joseph B. Gilder 879
BURGOYNE'S SURRENDER, AFTER. (Illustrated)	739
BUTTONS AND BULFON-HOLES. (Illustrated by C. M. Relyea)	Klyda Richardson Steege 1122
BY THE SEA IN AUGUST WEATHER. Verse. (Illustrated by H. R. Cort and A. G. Learned)	Ruth Kimball Gardiner 1110
CADDY, A. Verse. (Illustrated by the Author)	Margaret Hamilton 906
CANDY PILL AT SEA, A. (Illustrated)	Bess Goe Willis 180
CANDY STORE, THE. Picture, drawn by Anna B. Craig	C. W. K. 620
CHANGE OF CRAFTS, A. (Illustrated by George Varian)	1029
CHILDREN'S CELEBRATION OF HALLOWE'EN, A. (Illustrated from photographs)	Richard W. Child 961
CHIMNEY-SWEEP'S NEST, A. (Illustrated from a photograph by the Author)	Isabel Gordon Curtis 1124
CHUCKIE WUCKIE STORIES. (Illustrated by Albertine Randall Wheelan)	Russell M. Coryell 1019
COMMODORE'S CUP, THE. (Illustrated by C. M. Relyea)	Isabel Gordon Curtis 838,
CORNER CUPBOARD, THE. (Illustrated by C. M. Relyea)	934, 1030
COSTUME-PARTY, A. Pictures	William B. McCormick 865
COURT NEWS. Verse. (Illustrated by the Author)	Margaret Johnson 777
COW ACCOUNT, A. Verse. (Illustrated)	832
DAISY-FIELD, A FOURTH OF JULY MORNING IN THE. Photograph	Lucy Fitch Perkins 893
DIFFERENCE, THE. Verse. (Illustrated by Bess Goe Willis)	Charles Love Benjamin 967
DIFFICULT SUBJECT, A. Picture, drawn by E. Warde Blaisdell	776
DODGE, MARY MAPES, IN MEMORY OF. (Illustrated)	Caroline M. Cormick 1028
EDGAR'S "SISSY" JOE THAT PAID. (Illustrated)	929
ELEPHANT AND HIS SCHOOL, THE. Verse. (Illustrated by David Ericson)	William Fayal Clarke 1059
ELF'S ELECTRIC FAN, THE. Verse. (Illustrated by the Author)	Louise J. Strong 894
	Ellen V. Talbot 1020
	Peter Newell 1027

	PAGE
FAIRYLAND BELLMAN, THE. Verse. (Illustrated by the Author).....	<i>Margaret Ely Webb</i> 624
FEEDING THE CHICKENS. (Illustrated).....	<i>Stella George Stern</i> 933
FIRST AID TO THE INJURED.....	<i>Dr. Emma E. Walker.</i>
Burns.....	634
Fractures.....	697
Drowning.....	830
Sunstroke.....	927
Poisons.....	1021
Wounds and Hemorrhages.....	1103
FIRST VOYAGE OF "THE BROTHERLY LOVE," THE. (Illustrated by W. L. Jacobs)	<i>Elizabeth Hill</i> 675
FISHER-BOY OF THE EUPHRATES, THE. Verse. (Illustrated by Jessie McDermott Walcott).....	} <i>Margaret Johnson</i> 717
FLICKER FAMILY, PHOTOGRAPHING A. (Illustrated from photographs by Herman T. Bohlman).....	} <i>William Lovell Finley</i> 802
FLOWER NAMES. ("How Some Flowers Got their Names").....	<i>E. B. H.</i> 725
FOOLISH ELIZABETHANS, THE. Verse. (Illustrated by R. B. Birch).....	<i>Carelyn Wells.</i> 700
FOURTH OF JULY MORNING IN THE DAISY-FIELD, A. Photograph.....	776
FRIEND WITH BRASS BUTTONS, THE. (Illustrated by Albertine Randall Wheelan)	<i>Isabel Gordon Curtis</i> 1030
FROLICHSOME PLAYFELLOW, A. Poem.....	<i>George Bancroft Griffith</i> 739
GOOD SAMARITAN, THE LITTLE. (Illustrated by the Author).....	<i>Meredith Nugent</i> 1081
GOOSE GIRL, THE. Verse. (Illustrated by the Author).....	<i>Lucy Fitch Perkins</i> 810
GREAT WHITE HORSE, THE STORY OF THE.....	<i>Julian Ralph</i> 898
GUNDA. (Illustrated from photographs).....	<i>Helen D. van Eaton</i> 1090
GUNNERS, THE. Verse. (Illustrated by C. M. Rogers).....	1083
HALLOWE'EN, A CHILDREN'S CELEBRATION OF. (Illustrated from photographs)	<i>Isabel Gordon Curtis</i> 1124
HALLOWE'EN PROCESSION, A. Picture, drawn by S. B. Pearce.....	1127
HANDSOME IS AS HANDSOME DOES. Verse. (Illustrated by A. G. Learned).....	613
HER VERY OWN. (Illustrated from a photograph).....	<i>Florence A. Pardee</i> 820
HIS CADDY. Verse. (Illustrated by the Author).....	<i>Bess Gee Willis</i> 680
HOLE IN THE CANNA-BED, THE. (Illustrated by Albertine Randall Wheelan)	<i>Isabel Gordon Curtis</i> 934
HOME SKETCHES. Pictures, drawn by Rose Mueller Sprague.....	1012
HONEY-BEE. Verse. (Illustrated by the Author).....	<i>Lucy Fitch Perkins</i> 811
HOW SOME FLOWERS GOT THEIR NAMES. (Illustrated).....	<i>E. B. H.</i> 725
HOW TEDDY SAW THE KING. (Illustrated by George Varian).....	<i>Dorothy Brooks</i> 771
HOW THEY CELEBRATED. Verse. (Illustrated).....	<i>Edwin L. Sabin</i> 837
HOW TO STUDY PICTURES. (Illustrated).....	<i>Charles H. Caffin.</i>
Hobbema and Claude Lorraine.....	614
Reynolds and Gainsborough.....	683
Constable and Turner.....	806
Breton and Millet.....	902
Fortuny and Von Piloty.....	998
Whistler and Sargent.....	1004
IF I WERE QUEEN. Verse. (Illustrated by the Author).....	<i>Lucy Fitch Perkins</i> 1099
"I KNOW A VERY ANCIENT GAME." Verse. (Illustrated by Geo. R. Halm).....	<i>E. E. Sterns.</i> 601
"I LOVE YOU" STORY, THE. (Illustrated by Albertine Randall Wheelan).....	<i>Isabel Gordon Curtis</i> 838
IMPUDENT GUINEA-PIG, THE.....	<i>Charles F. Lummis.</i> 908
IN 1905. Picture, drawn by C. T. Hill.....	636
INDIAN STORIES. ("Stories Told by Indians").....	<i>Julian Ralph</i> 898
IN MERRY ENGLAND. Verse. (Illustrated by the Author).....	<i>Lucy Fitch Perkins</i> 618
IN THE WORLD WITHOUT A SUN. (Illustrated by I. W. Taber).....	<i>H. S. Canfield</i> 588
JEREMI' AND JOSEPHINE. Verse.....	<i>Laura E. Richards</i> 1121
JINGLES.....	601, 613, 617, 618, 619, 637, 696, 743, 810, 811, 820, 879, 892, 893, 910, 920, 925, 967, 1002, 1027
JOHNNY AND THE PARROT. (Illustrated).....	<i>S. G. S.</i> 743
JUNE EVENING ON THE BROOKLYN BRIDGE, A. Picture, drawn by A. B. Doggett.....	739
KALISTA WISEFELLOW. (Illustrated by C. M. Relyea).....	<i>Mary Dillon</i> 644
LITTLE GOOD SAMARITAN, THE. (Illustrated by the Author).....	<i>Meredith Nugent</i> 1081
M. M. D. Verse.....	<i>R. W. Gilder</i> 1071
M. M. D. Verse.....	<i>Josephine Daskam Bacon.</i> 1071

MAIDEN AND THE CRAB, THE. Verse. (Illustrated by L. Heustis)	<i>Stephen Blair</i>	925
MAIDS AND THE MOLLO, THE. (Illustrated by C. M. Relyea)	<i>Margaret Johnson</i>	968
MARY AND HER GARDEN. Verse. (Illustrated by Katharine Gassaway)		920
MARY MAPES DODGE, IN MEMORY OF. (Illustrated)	<i>William Fayal Clarke</i>	1059
MAY-DAY PARTY, A. Picture, drawn by C. M. Relyea		610
MESSENGER, A. Verse.	<i>L. S.</i>	909
MOTHER'S BURDENS, A. Picture		1008
MUD-PIES. Verse. (Illustrated by Florence E. Storer)	<i>Carolyn Wells</i>	785
NAN-AB-BEJU, THE STORY OF. (Illustrated)	<i>Julian Ralph</i>	900
NARROW ESCAPE, A. (Illustrated)	<i>H. A. Johnson</i>	931
NATURE-LESSON, A. Verse. (Illustrated)	<i>Carolyn Wells</i>	1102
NEW DOLL, THE. Verse. (Illustrated)	<i>M. M. D.</i>	820
NEW MAN, THE. Picture, drawn by E. Waide Blaisdell		975
NILE-GREEN COLLAR, THE QUEST OF A. (Illustrated by C. M. Relyea)	<i>Carroll Watson Rankin</i>	889
NOCTURNAL SAILOR, A. (Illustrated)	<i>Mervith Nugent</i>	932
NONSENSE RHYME. (Illustrated)		910
OLD WIDOW AND HER CAT, THE. (Illustrated)	<i>H. Maria George</i>	911
ONE DAY IN THE COUNTRY. Picture, drawn by Florence E. Storer		696
ON THE HILLSIDE. Picture, drawn by Bessie Collins Pease		881
ON THE HILLSIDE. Verse. (Illustrated by the Author)	<i>F. S. Gardiner</i>	885
OPTICAL ILLUSION, AN. (Illustrated by James Carter Beard)	<i>B. J. C.</i>	926
OUR FRIENDS, THE TREES. (Illustrated from photographs)	<i>Edwin W. Foster</i>	577, 703, 812
OWL AND THE PUSSY-CAT, THE. Picture, drawn by C. T. Hill		1002
PANAMA CANAL, A LITTLE TALK ABOUT THE. (Illustrated)	<i>Walter Kenyon</i>	1100
PAPER-DOLLS. Verse. (Illustrated by the Author)	<i>Ruth Ingraham</i>	637
PAYING THE DOCTOR'S BILL. Picture, drawn by Albert B. Blashfield		989
PENCIL BEWITCHED, THE. (Illustrated)	<i>Benjamin Webster</i>	702
PHOTOGRAPHING A FLICKER FAMILY. (Illustrated from photographs by } Herman T. Bohlman) }	<i>William Lovell Finley</i>	802
PHOTOGRAPHING A WILD FOX. (Illustrated from photographs by the Author)	<i>Silas A. Lottridge</i>	721
PICTURES		600, 636, 696, 702, 732, 739, 776, 795, 827, 829, 832, 833, 870, 876, 877, 878, 881, 929, 975, 989, 993, 1002, 1010, 1011, 1012, 1013, 1029, 1072, 1098, 1103, 1121, 1127
PINKEY PERKINS: JUST A BOY. (Illustrated by George Varian)	<i>Captain Harold Hammond,</i> <i>U. S. A.</i>	
How Pinkey Delivered an Address		605
How Pinkey Closed the School Term		733
How Pinkey Celebrated the Glorious Fourth		796
How Pinkey Settled an Old Score		871
How Pinkey Triumphed by Diplomacy		1022
How Pinkey Treated the Public		1084
PLYMOUTH ROCK, A VISIT TO. (Illustrated from photographs)	<i>Cornelia Hickman</i>	994
POLLY PORTER. (Illustrated by C. H. Stevens)	<i>Mary Rice Miller</i>	742
PRACTICAL BOY, THE. (Illustrated)	<i>Joseph H. Adams</i>	
Boats		639
Tents and Water-wheels		799
Tree-huts		822
Pets' Shelters		921
Home-made Gymnasium		1014
Electrical Apparatus		1113
QUEEN ANNE MAKES HER LACE. Picture, drawn by Margaret Ely Webb		829
QUEEN ZINI OF IX. (Illustrated by Frederick Richardson)	<i>L. Frank Bauson</i>	593, 688, 786, 882, 975, 1073
QUEER CARRIERS. (Illustrated)	<i>Gerrish Eldredge</i>	628
QUEST OF A NILE-GREEN COLLAR, THE. (Illustrated by C. M. Relyea)	<i>Carroll Watson Rankin</i>	889
RIDGE'S TRIPLE PLAY. (Illustrated by C. M. Relyea)	<i>Marjorie Allison</i>	681
SILHOUETTES OF THE STATES AND TERRITORIES. Drawn by H. Bridwell		1010
SISTERS, THE. Verse. (Illustrated)	<i>Stella George Stern</i>	1020
SMALL MUSICIAN, A. Verse. (Illustrated by Penrhyn Stanlaw)	<i>Norman W. Gray</i>	925
SOLID OLD MAN OF BUSINESS, THE. Verse. (Illustrated by C. T. Hill)	<i>Walter Camp</i>	828

	PAGE
STATES AND TERRITORIES IN SILHOUETTE. Drawn by H. Bridwell.....	1010
STORIES TOLD BY INDIANS. (Illustrated).....	<i>Julian Ralph</i> 898
SUMS, SOME SIMPLE. Verse. (Illustrated).....	<i>Charles Love Benjamin</i> 967
SUSIE AND WINNIE AND THE BALLOON. (Illustrated by Olive Rush).....	<i>Alice H. Lovie</i> 625
SWALLOW'S REVENGE, THE. (Illustrated).....	<i>Margaret Watson</i> 793
TACKS ON TEA. Verse. (Illustrated).....	<i>Charles Love Benjamin</i> 967
"THE HORSEMAN, THE PARSON." Verse. (Illustrated by George R. Halm).....	<i>E. E. Sterns</i> 601
THOUGHTS IN CHURCH. Verse. (Illustrated by the Author).....	<i>Lucy Fitch Perkins</i> 619
TIMMIE TOOLE AND WILLIE WISE. Verse.....	<i>Louisa Fletcher Tarkington</i> 1019
TIN-PEDDLER, THE. Verse. (Illustrated by the Author).....	<i>Lucy Fitch Perkins</i> 1003
TOTSI AND THE CHERRY-BOUGH. Verse. (Illustrated by Jessie McDermott } Wolcott).....	} <i>Margaret Johnson</i> 1105
TOWSER AND THE RAT. Picture, drawn by L. Hopkins.....	702
TREES, OUR FRIENDS THE. (Illustrated from photographs).....	<i>Edwin W. Foster</i> 577, 703, 812
TWINS, THE. Verse. (Illustrated by George R. Halm).....	<i>E. E. Sterns</i> 743
TWO BOYS AND TEN MILLION MOSQUITOES. (Heading by Phillips Ward).....	<i>Frank J. Stillman</i> 1004
TWO FUNNY FRENCH BEARS. (Illustrated by the Author).....	<i>Meredith Nugent</i> 602
TWO LITTLE GIRLS, A LITTLE STORY OF.....	<i>Stella George Stern</i> 732
UNFAIR ADVANTAGE, AN. Picture, drawn by E. Warde Blaisdell.....	1103
VACATION IN FAIRYLAND. Pictures, drawn by Elise Bohm.....	702
VALOR. Verse. (Illustrated by the Author).....	<i>Lucy Fitch Perkins</i> 892
VANDALS, THE. Verse. (Illustrated by A. G. Learned).....	<i>Lucy L. Cable</i> 708
VENUE. (Illustrated).....	<i>John Mott</i> 622
VIRGINIA CREEPER, A GENUINE. Picture, drawn by E. W. Kemble.....	732
WARBLER WAYS. (Illustrated from photographs by Herman T. Bohlman).....	<i>William Lovell Finley</i> 916
WELL-TAUGHT LESSON, A. Verse. (Illustrated by Katharine N. Richardson).....	<i>Clara Odell Lyon</i> 879
WHAT UNCLE TOM DID. (Illustrated).....	<i>Elizabeth Price</i> 990
WHEAT-FIELDS OF CALIFORNIA, SCENES FROM THE GREAT. From photographs.....	876
WHEN DICK WENT TO THE RACE. (Illustrated by C. M. Relyea).....	<i>Elsie Carmichael</i> 834
WHEN TO CRY.....	<i>Mary Elizabeth Stone</i> 878
WHERE THE REVOLUTION WAS FOUGHT. Picture, drawn by H. L. Bridwell.....	827
WHICH SHALL BE MAY-QUEEN? Verse. (Illustrated by Isabella M. Davis).....	617
WHITE HORSE, THE STORY OF THE GREAT. (Illustrated).....	<i>Julian Ralph</i> 898
WHO IS IT? Verse. (Illustrated by Isabella M. Davis).....	<i>Will P. Snyder</i> 699
WILFUL KANGAROO, THE. Verse. (Illustrated by R. B. Birch).....	<i>Ellen F. Talbot</i> 632

FRONTISPIECES.

"Queen Zixi rode out at the head of her army," by Frederick Richardson, page 576—"She ushered Margaret into the room," by W. L. Jacobs, page 674—"How Teddy saw the king," by George Varian, page 770—"Queen Zixi greeted Bud and his sister," by Frederick Richardson, page 864—"We have lost a beautiful cloak," by Frederick Richardson, page 960—Mary Mapes Dodge, from a photograph, page 1058.

DEPARTMENTS.

	PAGE
ST. NICHOLAS LEAGUE. (Illustrated).....	656, 752, 848, 944, 1040, 1136
NATURE AND SCIENCE. (Illustrated).....	648, 744, 840, 936, 1032, 1128
BOOKS AND READING. (Illustrated).....	668, 764, 860, 956, 1052, 1148
THE LETTER-BOX. (Illustrated).....	670, 766, 862, 958, 1054, 1150
THE RIDDLE-BOX. (Illustrated).....	671, 767, 863, 959, 1055, 1151
EDITORIAL NOTES.....	862, 958, 1054, 1150



F. RICHARDSON

"QUEEN ZINI RODE OUT AT THE HEAD OF HER ARMY, CLAD IN A SUIT OF MAIL."

ST. NICHOLAS.

VOL XXXII.

MAY, 1905.

No. 7.



BY EDWIN W. FOSTER.

To know the trees, especially our fine American forest trees, is to possess friends whose character can always be depended upon, and whose intimate acquaintance brings continual and increasing pleasure.

It is surprising how few people know even a very little about our trees; and this is as true of country people as it is of those who live in cities. Perhaps it is because the scientists have frightened people with their formidable Latin names, but whatever the cause, the fact remains that few people can walk through the woods or parks and name correctly half a dozen trees.

As one becomes acquainted with these noble and beautiful plants, he soon finds that each tree differs from every other tree just as each human being differs from his fellows, and yet there are families and classes of trees just as there are races and nations among men.

It is quite a wonderful thing to know that in a forest containing thousands of trees, with their millions of leaves, no two leaves are exactly alike, and yet we can readily distinguish the maple leaves from those of the oak, the beeches from the birches, and so on through the list, just

as we can tell Chinese from negroes, and Indians from white men, in the human family.

On the other hand, some leaves are so nearly alike that we must observe them very carefully in order to discover whether they belong to the same kind of tree. For example, in Figs. 5 and 6 on page 581, we have two leaves which at the first glance seem quite similar, but which on closer examination prove quite different. The one on the left is the chestnut, so dear to all of us, while the other, which is wider and has rounded instead of sharp teeth along its edges, is the chestnut-oak.

Of course if we had the two trees standing side by side we could distinguish them immediately by their fruit, because one would bear burs containing chestnuts and the other acorns. The chestnut-oak is a true oak, and is so named simply because its leaves so closely resemble those of the chestnut. It is a noble tree, and grows to a great size, often being found a hundred feet in height. There is one near Fishkill-on-the-Hudson famous for its age and size. This tree is seven feet in diameter. It is claimed that in 1783 Washington used to

Copyright, 1905, by THE CENTURY CO. All rights reserved.

mount his horse under it when he rode from his headquarters to the army encampment at Fishkill.

Sometimes we better appreciate the value of a tree if we know of what use it is to us. The chestnut-oak, besides being one of our most beautiful trees and valuable for the timber it furnishes, has a bark which is rich in tannin, a substance used extensively in tanning leather.

The chestnut-tree needs no description to American boys and girls, as we all have spent glorious days in the crisp autumn weather searching for the plump brown nuts in the dry leaves, and afterward roasting them over blazing hot fires during the long winter evenings.

The boys may be interested to know that chestnuts prove a very profitable crop. Experts claim that an orchard of chestnuts will bring greater returns to the owner than an apple-orchard of the same size, as the nuts are retailed on the street corners at about six dollars a bushel, while the Italian who sells roasted chestnuts receives pay for them at the rate of at least eight dollars a bushel.



FIG. 1. A CHESTNUT-TREE STRIPPED OF ITS FOLIAGE.

The tree is one of our most rapid growers, and has been known to bear fruit at five years of age.

THE OAKS.

THE large family of American oaks is one of which we are justly proud, and it is difficult to say which is the finest. Among trees the oak

stands for all that is sturdy, reliable, hardy, and useful—a symbol for the honest, true, and patriotic citizen among men. Although it is perhaps not as graceful as the elm, nor as luxuriant as the magnolia or the palm, its strong and heavy trunk, its gnarled branches, and its clean, healthy foliage give it a prominent place among our American trees. Its wood ranks high as valuable timber, being strong, hard, and durable, with a handsome grain which takes a fine polish.

Figs. 7 and 8 show the leaves of the two oaks



FIG. 2. A POST-OAK.

which are the best known and most common about New York City. Their leaves are so different that they can never be confounded. The white-oak leaf is deeply indented and has rounded lobes; there is not an angle nor sharp point anywhere on the leaf; while the red-oak leaf on the right is sharply toothed and bristling with points. Both of these leaves are large, the white-oak being of a beautiful light-green color, while the red-oak is darker, stiffer, and very glossy.

Both trees grow to a very large size, and their timber, which is used extensively in ship-building, carriage-making, cooperage, and cabinet-work, is the standard among woods for strength and durability.

There are several kinds of oak closely related to these two trees. For instance, the post-oak (Figs. 2 and 9) has a leaf resembling the white-oak in shape, yet it is a simple matter to

distinguish either the trees or individual leaves. The leaves of the post-oak are very much darker, thicker, and more leathery than the delicate and refined leaf of the white oak, and the indentations are not so deep. The whole tree is rougher in its bark, leaves, and general appearance, and the leaves have a habit of

finest development in the Mississippi valley, but is occasionally found in the Eastern States. It grows to a great height,—one hundred and fifty feet being not unusual,—and its wood is of a superior quality.

The great oak family might be divided into two classes: those that ripen their acorns in



FIG. 3. A WHITE OAK.

clothing the entire branch, from the point where it leaves the trunk out to the very tip. The wood is so hard that the tree is often called the iron-oak. It is very common on Long Island and all along the eastern coast.

Another tree which resembles the white oak is the magnificent mossy-cup or overcup oak, with its long, shiny leaves, which are sometimes a foot in length. Figs. 11 and 12 show the difference between the two leaves; but the principal points of difference are the peculiar, corky ridges found on the young branches of the mossy-cup and the beautiful, single acorns of the latter, with the heavy fringe around the nuts, from which the tree takes its name. This tree is primarily a Western oak, and reaches its

one season, such as the white, post, and mossy-cup oaks just mentioned, and those which require two full years, such as the red, scarlet, and black oaks. To the first class belong the chestnut-oak and the live-oak of the South. This latter tree for generations played an important part in ship-building, but has now been superseded by iron and steel. The leaf, which is an evergreen, is entirely without indentations, and is thick and leathery. The wood is very heavy and strong, has a beautiful grain, and is susceptible of taking a high polish. At one time this wood was so valuable that our government paid two hundred thousand dollars for large tracts of land in the South, that our navy might be sure of a supply of live-oak timber.

To the second class of oaks we are largely indebted for the gorgeous colors of our autumn leaves. The red, scarlet, and pin oaks, with their brilliant reds, scarlets, and browns, are close competitors with the maples in giving our American landscapes the most wonderful autumn colorings to be found anywhere in the world. These three trees have leaves which at first glance are quite similar, but by careful examination may always be distinguished.

The red-oak leaf is an unusually large one, of a dark-green color and very shiny. By com-



FIG. 4. A YOUNG PIN-OAK.

paring the sketch of it with that of the scarlet oak, it will be apparent that the indentations are not nearly as deep in the former, which has a broad, massive appearance, while the latter is so deeply indented as to give a skeleton effect. The deeply cut foliage of the scarlet oak makes it the more handsome tree of the two, but each of these oaks grows to a large size and is valuable both as a shade and a timber tree.

The novice at tree study is much more apt to confuse the scarlet and pin oaks than the red and scarlet. Referring again to the diagram of leaves, one sees at a glance that the pin-oak has a smaller leaf than the scarlet oak, and this difference in size appears to even better advantage on the trees than in the drawing.

The pin-oak, which has recently become a favorite among nurserymen as an ornamental tree, takes its name from the pin-like appearance of the tiny branches which sprout from the main trunk and the limbs; its timber, however, is not as valuable as some of the other oaks. No list of oaks which are common about New York would be complete without the black-oak and black-jack varieties. These two trees—the latter being sometimes called the barren oak—thrive in exposed and sterile regions such as the sandy flats of New Jersey and Long Island, where no other tree except a stunted pine seems able to live. Their whole appearance, from the individual leaf to the framework of the stripped tree, is summed up in the two words "tough" and "rugged." The leaves are tough and leathery, while the wood is gnarled and strong, and altogether these trees are in perfect harmony with their wind-swept surroundings. The leaf of the black-jack oak (Fig. 16) may be easily recognized by its three lobes or rounded points, from which it rapidly tapers to a point at the stem. The leaf of the black oak (Fig. 17) is very slightly indented for an oak leaf, the sharp points being few, far apart, and separated by shallow recesses, as shown in the sketch.

Occasionally one will find in the parks or along the roadside an oak which bears fine, large acorns, with a leaf which somewhat resembles our white oak, but is poorer, smaller, and very inferior in size and symmetry. This is the famous English oak (Fig. 15), which has been imported into this country as a shade-tree. A curious thing in connection with this leaf is the fact that practically all of the wood-carving we use, in which oak leaves and acorns are prominent features, represents the English oak. Our artists will find a mine of wealth in our American oaks and acorns that has hardly been touched.

Then, too, we find some interesting freaks in the oak family: such as the willow-oak, whose leaves closely resemble the long, narrow, and familiar leaves of the willow; and the laurel-oak, whose thick, glossy, and dark-green leaves remind us of our evergreen laurel. These two varieties are not common around New York, however, but reach their highest development in the South and West; the willow-oak being a

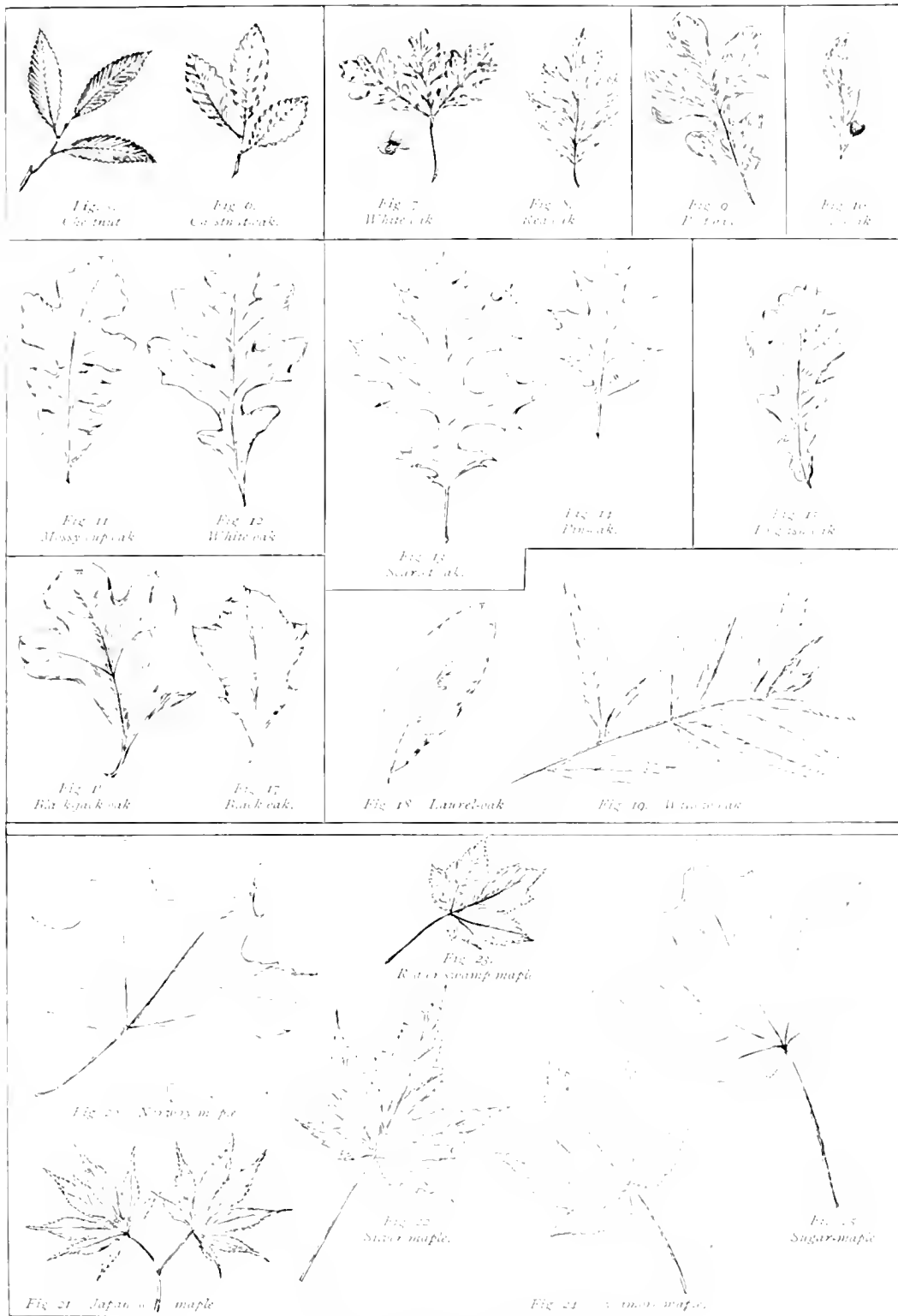

Fig. 5
Chestnut

Fig. 6
Chestnut oak

Fig. 7
White oak

Fig. 8
Red oak

Fig. 9
F. latifolia

Fig. 10
Chestnut oak

Fig. 11
Mossy cup oak

Fig. 12
White oak

Fig. 13
Scarlet oak

Fig. 14
Pin oak

Fig. 15
English oak

Fig. 16
Bitternut oak

Fig. 17
Black oak

Fig. 18
Laurel oak

Fig. 19
White oak

Fig. 20
Norway maple

Fig. 23
Rice swamp maple

Fig. 22
Siberian maple

Fig. 24
Sugars maple

Fig. 21
Japan maple

Fig. 24
Sugars maple

DIAGRAM OF OAK AND MAPLE LEAVES.

remarkably beautiful shade-tree, familiar to all dwellers below Mason and Dixon's line.

THE MAPLES.

But all fine trees do not belong to the oak family; indeed, we have in the maple group a list which gives the oak group a very close race. From the dwarf Japanese maples with their purple foliage, which is so delicate and feathery that one wonders how it can ever withstand the elements, up to the sycamore-maple, whose leaves are often quite a foot long and so strong and big as to give it the nickname "false sycamore," this group is of constant interest and usefulness, with not a black sheep in the family.

It is to this race of trees that we are indebted for nearly all the cool shade in our sweltering cities; in fact, these trees must be possessed of unusual vitality, because, although of delicate and refined foliage, they seem better able to stand the smoke and gases of large cities than any other group, with a few exceptions.

The Japanese maples were, as their name implies, imported from Japan, and are noticeable on lawns and in the city parks for their reddish-purple coloring and the deep-cut leaves.



FIG. 26. YOUNG SILVER MAPLES.

These indentations extend almost to the stem of the leaf, cutting it into five or seven distinct fingers, which in some cases are so slender as to give it the appearance of a feather rather than a leaf. Prospect Park, Brooklyn, has a particularly large and fine collection of these tiny trees or shrubs. The red or swamp maple, the wild species of our woods, has a small leaf, very easy to distinguish. It is divided into three main points, each of which is cut up by small teeth along its entire edge. They are famous for their brilliant red colors in the fall. The highest pinnacle of tree development, however, seems to have been reached when the silver maple was formed in nature's crucible. Think of all the good points in a physically perfect, high-strung, blooded horse, apply these points to tree life, and we have the silver maple. From the ground up to the topmost leaflet we find expressed in every atom of the tree strength, vitality, purity, beauty, and usefulness. The trunk of this tree is as sleek and clean-cut as any one could imagine a tree to be. The leaf is beautiful in its shape and color, the under side being a silvery white,—from which it takes its name,—and as one stands under it and looks up he sees a silver dome; or if a breeze is blowing, the green-and-silver leaves shimmer and vibrate like an aspen, giving the appearance of pale-green fire, which is especially noticeable on the approach of a storm. The leaf is five-pointed, and the entire edge is again indented with well-defined teeth. This is the common shade-tree of our cities.

Another shade-tree very common in our cities is the imported Norway maple. This tree is made of rather coarser and sterner stuff than its tall and stately silver brother. It may be distinguished from the other, not only by the leaf-form shown in Fig. 20, but also by the dense, dark-green foliage, the very dark bark, and by its low and compact form. Its leaf somewhat resembles that of the sugar-maple, but the latter has coarser teeth with blunt points. Our boys and girls will always associate maple-trees with buckwheat-cakes, but only the true sugar-maple furnishes us with maple-syrup. The boring of the trees is a part of the process, which requires considerable judgment. In order to prevent killing the

trees, only one boring must be made each year, and the weather must not be too cold nor too hot. When the sap begins to flow in the trees the winter is supposed to be about over and the spring at hand.

The sycamore-maple, frequently seen along with our silver and Norway maples, has an unusually strong and heavy leaf. It may be easily distinguished by its long, thick red stem, by its five distinct fingers, and by the fact that the entire edge of the leaf is finely toothed, in

which respect it differs from all the other maples. This tree is a great favorite in Europe, where it is often planted to the exclusion of other shade-trees.

We have fancy and curious varieties of maples just as we have among other groups. For instance, the cut-leaf silver maple, which is similar to the ordinary silver variety except that its leaf is more deeply cut and indented, also the ash-leaved maple, whose leaf reminds us of the ash; and a number of others.

(To be concluded.)

THE BIRTHDAY OF VIRGINIA.

BY EMBLIGH MERWIN.

ALL this might not have come about if Virginia had not been invited to Florence Patterson's birthday party, and if her own birthday had not been the same as that of her mother—the young mother whom she could hardly remember.

Virginia sat thinking about the party and living it over again—Florence was such a dear girl, Florence's mother was *so* charming; the table, with its big birthday cake, had been beautiful, and it was *such* fun to run upstairs with the other girls and witness Florence's delight over her gifts, spread out on a table.

Virginia's own birthday, December 10, was only three weeks away; but she knew quite well there would be no party, no gift-covered table. Grandpa did not approve of making a fuss over birthdays and Christmases.

As she sat brushing her hair the night after Florence's party, Virginia was sad—just a little. If one only had one's own mother! Virginia stared hard at the photograph on her bureau, and winked away a tear. She knew it was n't right to let herself feel sad—her lovely mother, whom every one praised, had been like the sunshine, every one said. Virginia wished sincerely that she were like her mother; it seemed as though being born on her birthday ought to help.

Virginia Greene lived with her grandfather, Judge Atkins, and his twin daughters, Mary and Esther. His two younger children, Edward and Margaret,—Virginia's mother,—had seemed to belong to a different generation from the elderly twins. Away at school much of the time after their mother's death, both Edward and Margaret had married early and gone to live far from the old New England home. There Judge Atkins and his older daughters had grown old and dignified together.

One day the judge, his face very sorrowful, had started suddenly on a journey. When he returned, looking still sadder and older, he led a frightened child of six by the hand. Margaret and her husband had died within the same week, and the judge was bringing Margaret's little girl, Virginia, to his own home.

So, for five years, Virginia had lived with the three old people.

Virginia's grandfather promptly engaged tutors and a music-teacher from Boston. Often, while Virginia slept in the pretty room that had been Margaret's, Judge Atkins and his daughters downstairs held consultation concerning the welfare of Margaret's child.

Virginia's dresses were the admiration of all the girls. Aunt Mary and Aunt Esther made

them, of the finest materials, with exquisite handiwork, employing the dressmaker merely to insure correctness in fashion.

Virginia knew that she was a well-cared-for and fortunate girl, and reminded herself of it again and again, especially on occasions such as the night after Florence's party.

"You know very well," Virginia said to herself in the glass, "that grandpa does n't like noise and fuss. Maybe you won't, either, when you get to be as old as he."

"But," objected the Other Virginia, who was also herself. "Christmas trees are such fun, and a birthday with presents on a table in your own room, and all the girls running in to see, would be *so* nice and — *mother-y*."

There were times when Virginia had to deal severely with the Other Virginia. "Are n't you *ashamed*, Virginia Greene," she said sternly, "always thinking about your own pleasure, even when you're sitting right here before your mama's picture — she who *never* thought about herself!"

The most precious legacy left by Margaret Atkins to her child was the universal testimony to the sunny sweetness of her nature, her forgetfulness of self, her vivid interest in whatever concerned those near her.

"You're not a *bit* like her," continued Virginia, "even if you were born on her birthday. Do you suppose *she* would be thinking about tables covered with presents for herself?"

The scolding of the Other Virginia came to a sudden end, the hair-brush stopped midway — a glorious idea leaped into existence.

Before she fell happily asleep she had planned it all out — she would celebrate her own birthday and her mother's!

No one thought anything of it that Virginia,

during the next weeks, kept pretty closely in her own room after school. The aunts were always busy with the affairs of the orderly household. Besides, Virginia was always quiet; she respected grandpa's dislike of noise.

Virginia's birthdays were by no means entirely overlooked. It was the judge's custom to add, on her birthday and on Christmas, fifty



"YOU KNOW VERY WELL," SAID VIRGINIA TO HERSELF IN THE GLASS.

dollars to the sum accumulating for the college expenses of Margaret's child; his daughters gave twenty-five dollars each.

Few girls receive gifts of the value of one hundred dollars. Yet, deep in her heart, Virginia preferred the tree and the party for her girl friends, although she said that grandpa was

"so kind" and Aunt Mary and Aunt Esther "did *everything*." Indeed, the judge and his daughters would have given their last dollar for Margaret's child; they did not know that her life lacked anything.

On Friday evening, the 9th, Judge Atkins looked up from his newspaper to his daughters busily sewing on Virginia's things, when the bell rang violently. It was a telegram from Edward: his wife, with the two children and nurse, would arrive in the morning for a week's visit.

When Virginia came down next morning, rooms were being prepared for the expected guests. This was but the third visit from Edward's wife since her marriage seven years before.

Virginia had somehow received the impression, from family discussions, that Aunt Gloria was — one might say, frivolous. "Gloria is a well-meaning girl," Aunt Esther would say defensively. "Yes," the judge would admit; "but not what you could call *dignified*." "A curious name — Gloria," Aunt Mary once commented. "But pretty, too, and suited to her," said Aunt Esther. "I prefer the sensible, old-fashioned names," said the judge, decisively.

Despite her long-standing desire to see Aunt Gloria, the news of her expected coming only sent Virginia directly to her room after breakfast. And when, later, that vivacious, auburn-haired lady herself arrived, with six-year-old Teddy and Baby Madge, Virginia stayed downstairs only to give them her shy greeting and then disappeared.

In the afternoon, the first excitement of the arrival over, Virginia's absence was observed.

"I've hardly seen Margaret's daughter; why does n't she come down?" asked Gloria.

As if to reply in person, Virginia appeared in the doorway. Her eyes shone; bright spots glowed in her cheeks.

"Grandpa," she began, "this is my birthday."

The judge considered.

"Yes, so it is." He nodded. "The 10th — Margaret's birthday, too."

"I declare I'd forgotten," said Aunt Mary.

Gloria stared; she could hardly imagine their forgetting Virginia's birthday.

"I want to invite everybody to my party — it's going to be a surprise!" said Virginia.

The expressions on the aunts' faces indicated that it was indeed a surprise! The judge looked amazed.

"Will you all please come upstairs?" continued Virginia.

At this, the three older people apparently lost their tongues in astonishment.

"I'm so sorry, Virginia," cried Aunt Gloria, "that I did n't know about your birthday. I wish we had come a day earlier."

"Oh, but it's so delightful that you are here to-day, Aunt Gloria!" said Virginia. "And please bring Teddy and Madge."

They all followed Virginia upstairs.

In the center of her room stood a small table covered with various parcels neatly tied with ribbons.

The red in Virginia's cheeks deepened. It was very embarrassing. But Margaret's daughter was, also, Judge Atkins's granddaughter — which meant that a thing once undertaken had to be carried through.

"I do *so* like birthday celebrations," she began; "especially a table with presents that are a surprise. But then I know it is n't nice to make a fuss. So I thought I'd just celebrate my birthday and mama's myself. And because it's mama's birthday, too, I thought of this way of celebrating — you know I'm not always like mama. I don't always remember about others first — it's hard for me. But this is n't only my party — it's *sort of* mama's party."

Virginia's eyes were stars, and her cheeks full-blown roses. Making a speech is exciting work. But she went on bravely:

"The night after Florence's party — her party was just lovely — I was thinking about — mama. And it just came to me then — now would n't it really be nicer to give presents on your birthday than to get them? And it's so much more proper, too, for a girl like me, that has so much, and every body doing things for me. So I'm celebrating our birthday by giving things to the people who are so good to me. And I *do* think it's the most fun. Grandpa, it really is blessed to give than to receive, just as you've told me."

The audience stood stock-still and quite silent. Aunt Gloria's eyes and cheeks rivaled Virginia's. But Virginia, her shyness lost now in eagerness, was too busy to observe.



BECAUSE IT'S MAMA'S BIRTHDAY, TOO, I THOUGHT OF THIS WAY OF CELEBRATING.

"This is for you, grandpa." She handed the bewildered old gentleman a little cardboard affair. "It 's to hold your reading-glasses — it hangs on the wall, you know; when you lay them on the mantel, they often get brushed off."

The distribution continued — handkerchiefs neatly hemstitched, be-ribboned pincushions, needle-books, and so on. Hannah, the cook, and Baby Madge's nurse, present by invitation, were not overlooked. Some gifts for Florence and two other friends were laid aside.

"I 'll take them over afterward," explained Virginia. "I did n't ask the girls to come, because — well, yes, grandpa, Florence *does* giggle sometimes, but she 's a nice girl, I think — don't you?" She smiled apologetically while she defended her absent friend.

"If I 'd only known you were coming," she said regretfully to Aunt Gloria, "I could have done so much better. It was lucky to-day is Saturday."

Aunt Gloria received a stock that showed some signs of hasty manufacture. Teddy was already racing up and down with a gorgeous pin-wheel. Baby Madge sat on the floor, smiling radiantly, her little fists full of gaily gowned paper-dolls and "peanut-men."

Teddy was the first to express himself — with the sincerity and emphasis of a six-year-old.

"Say, Virginia, if *anybody* 's all right, *you 're* all right!"

"You darling, you!" Aunt Gloria was clasping Margaret's child to her heart.

"Why, my dear, my dear, bless you! bless you!" faltered the judge.

"Father, she 's more like Margaret every day!" Aunt Esther actually kissed Virginia.

Aunt Mary had disappeared. When they finally went downstairs, there was a great fruit-cake on the table; Hannah, smiling delightedly, was bringing in tea. Aunt Mary was taking out her choicest china cups.

"This has been the loveliest birthday!" said Virginia, who was sitting happily in the circle of Aunt Gloria's arm, showing Baby Madge how to make her paper-dolls sit down.

"Father Atkins," Gloria said to the judge, "I want to take Virginia back with me to New York; I really need her help through the holidays."

Virginia fairly held her breath.

"She has no lessons next week," said Aunt Mary.

"And if Virginia would like to go — " began Aunt Esther.

"There 's no reason why she should n't," concluded the judge.

After Virginia had fallen asleep, the judge and his daughters sat below with their guest.

Gloria Atkins's pretty face wore a determined look. That strange, stiff old gentleman and those queer, elderly sisters-in-law were older than herself; still, she believed that they were making a mistake, and she was courageous.

"Do you really never do anything on Virginia's birthday?" she asked.

"Oh, yes," said Esther, hastily. "Father always puts away fifty dollars for her college money, and Mary and I add something."

"But what does a girl of her age know of a bank account? Besides, she will have her education, anyhow."

Gloria was quite respectful, but something in her voice made them uncomfortable. The judge settled the matter.

"Gloria," he said, a little huskily, "you are young, but you know some things I 'm too old to learn. Since you came I 've been seeing that we have missed giving Margaret's child the thing she needs most — her girlhood. God knows I would spare nothing, and the girls" — he meant his elderly daughters — "would give all they have for the child. But we 've left out something. Gloria, in the future I think we 'll have to look to you."

The twins were wiping their eyes — on handkerchiefs from "the table with presents that are a surprise." Gloria — impulsive, warm-hearted Gloria — had the judge's hand in both of hers.

"Father Atkins, *you* have done everything. I am the one to be blamed. I 'm ashamed that I have n't come out here before. I should have known there was something for me, too, to do for Margaret's motherless girl. And I have never even asked if you needed my help."

So out of that evening's talk came an understanding and a firm bond of friendship among those four that never failed; and that birthday of Virginia brought results far-reaching and very pleasant to all concerned.

IN THE WORLD WITHOUT A SUN

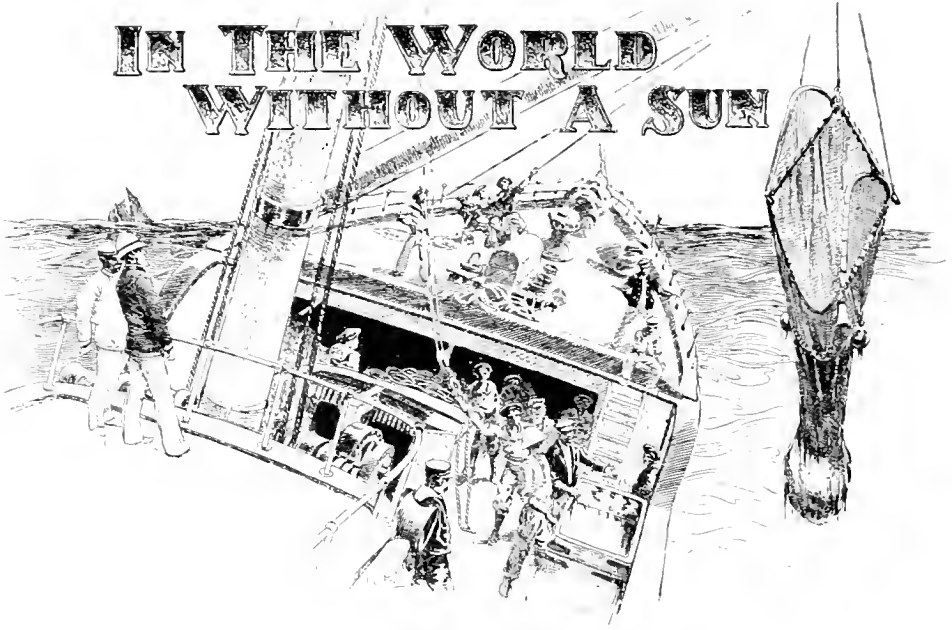

BY H. S. CANFIELD.

AMONG the passengers on board the United States steamship *Petrel*, detailed to make deep-sea soundings under the auspices of the Smithsonian Institution, were Professor George Crenshaw of the Smithsonian Institution and Robert Lessing, his nephew. Bob was recovering from typhoid fever, and his uncle had secured him the berth of "custodian of instruments." The opportunity for combining a health-giving cruise with the chance to earn a little money on so interesting an expedition was one not to be missed by the wide-awake boy.

The mission of the boat was to take soundings in the lower portion of the Caribbean Sea. She was small, trim, and powerful, and neat as a pin from stem to stern. Her officers were a jovial and gentlemanly crew, and they took a liking to the pale, quiet boy who was never in the way, did not ask needless questions, and seemed anxious to bear a hand at whatever would be useful. The professor was in his element, telling stories, singing snatches of sea-songs, and overhauling the instruments for specks of rust. They went by islands whose "shores, like playhouse scenes, slid past their wondering eyes." They plowed waters of a

blue almost dazzling. They sighted the Southern Cross, and that great constellation burned to the southward like a beacon. Then they slacked speed and began sounding.

The rope was made of thin wires; it ran from a reel full of levers, wheels, and cogs. The reel had brakes on it to counteract the increased weight of the wire as it paid out the miles; it was screwed firmly to a stout platform built out from the side of the ship. Utmost care was taken to prevent the wire kinking, for when it kinked it broke; otherwise, as the professor said, "it would hold a buckskin wale with black stripes around his legs." The weight to carry the wire down was attached to its end, and when bottom was reached this weight came off automatically and stayed down forever. Here and there above the weight instruments were attached. One of them was a thermometer, which did not act until it was within three feet of the bottom. Then it registered the temperature, set itself, and stayed set. There was a little box which opened itself at the bottom, filled itself with sea-water, and shut. There was a valved tube which collected mud or sand. There was a cylinder which



A GEMSE INTO THE WORLD WITHOUT A S.

registered the pressure of the water; sometimes it was as high as eight thousand pounds to the square inch.

"That pressure," said the professor, "would thin a man out like a pancake."

The *Petrel* was not only a sounder, but a fisherman, and it was this work which the professor was superintending and recording. When it began he was busy from morning until night, and had no time for jokes except such as forced their way out of him in spite of himself. He had great alcohol-jars in which the smaller specimens were preserved, and he walked around the bigger ones as they sprawled, and measured them and photographed them and examined their tissues in steady delight. He told Bob that the work was of exceptional interest, because scarcely a haul was made in which he did not see something that no man had ever seen before, despite the fact that deep-sea fishing had been going on for years; so vast is the ocean floor and so innumerable the varieties of the inhabitants.

On the deck were large steel drums with cables wound about them, and these pieces of intricate machinery let down the weighted trawls by steam and hauled them up. Once they were down the *Petrel* either steamed at one-eighth speed or drifted on the current, and after a while the strain was put on and the drums began to turn slowly in the uplift. At first the engines groaned, because the steel nets always became half sunken in the soft bed; but as they came up, the water washed the mud from their meshes, and they reached the vessel's side clean and alive with the most wonderful squirming or flapping things. Never a man in his wildest dreams had such visions as those which confronted the watchers on the *Petrel's* deck.

Bob got an object-lesson one day in the meaning of sea-pressure. The sounding-wire had been let down, with a hollow metal sphere attached just above the sinking-weight. This sphere was a foot in diameter and made of finely tempered steel. The wire was wound in, and not twenty feet away the fishing-trawl was also coming in. They reached the surface simultaneously as he peered over the side. The steel sphere had been mashed into a thin disk and one of its edges rolled over in a cylinder.

In the trawl were half a dozen specimens of deep-sea life, and one of them, as it came into the air, blew up like a toy balloon. This fellow had been taken about half-way up, and being used to a pressure of some thousands of pounds to the square inch had naturally expanded rapidly when that pressure was released.

"We have brought up thousands of species," said the professor one day, in a lecturing mood, "but the government cannot hope to secure a specimen of each of the varieties, for they are too many, nor can we hope ever to capture any one of the larger kinds. They are so enormous that we could not handle them if they were caught. We know enough about the world down there, however, to know that if man could visit it, all of the wonder-stories written since time began would seem tame beside the marvels unfolded. No human imagination is equal to picturing even the least grotesque of those forms; we need them actually before us to appreciate them; and each haul of the net produces things which seem only outrageous contortions of nature. There is no sun in those abysses under miles of water, not a ray of our light ever pierces to the entrances of the vast caverns; yet there is a strange and ghostly light made by the fishes themselves, and if we could see it, we would seem to be in a land haunted by gleaming specters of the horrible. Passengers in great steamers plow merrily only a mile or two above monsters that would send them into spasms of fright if they could be seen close at hand. The deepest haul of a net ever made in the world was achieved by Americans off the Tonga Islands in the South Pacific. The trawl struck bottom twenty-three thousand feet below the surface; that is considerably more than four miles down, but even at that depth animal life was found. Those strange beings lived in water whose temperature was constantly just above the freezing-point, and under a pressure of nine thousand pounds to the square inch. To sink that net and bring it back again took a whole day of steady labor."

As a rule, however, the professor was too busy to lecture. When waiting for the net to come up he was making notes, or writing reports, or bottling specimens, and once the haul was on deck he was a man possessed by a quiet

QUEEN ZIXI OF IX.

Copyright, 1905, by L. FRANK BAUM.

By L. FRANK BAUM,

Author of "The Wizard of Oz."

CHAPTER XIII.

TULLYDUB RESCUES THE KINGDOM.

ALL soldiers love to fight; so when the army of IX learned that they were to go to war, they rejoiced exceedingly over the news.

They polished up their swords and battle-axes, and sewed all the missing buttons on their uniforms, and mended their socks, and had their hair cut, and were ready to march as soon as the queen was ready to have them start.

King Bud of Noland had an army of seven thousand seven hundred and seventy-seven men, besides a general ten feet high; but the Queen of IX had an army more than twice as big, and she decided to lead it in person, so that when she had conquered the city of Nole she herself could seize the precious magic cloak which she so greatly coveted.

Therefore Queen Zixi rode out at the head of her army, clad in a suit of mail, with a glittering helmet upon her head that was surmounted by a flowing white plume. And all the soldiers cheered their queen and had no doubt at all that she would win a glorious victory.

Quavo the minstrel, who wandered constantly about, was on his way to Noland again; and while Queen Zixi's army was cutting a path through the forest and making a bridge to cross the river, he came speedily by a little-known path to the city of Nole, where he told Tullydub, the lord high counselor, what was threatening his king.

So, trembling with terror, Tullydub hastened

to the palace and called a meeting of the five high counselors in the king's antechamber.

When all were assembled, together with Bud and Fluff, the old man told his news and cried:

"We shall all be slaughtered and our king-



"THE GENERAL SAT DOWN SUDDENLY AND GREW PALE." (SEE PAGE 504.)

dom sacked and destroyed, for the army of IX is twice as big as our own"—yes, twice as big!"

"Oh, pooh! What of that?" said Tollydub, scornfully; "have they a general as tall as I am?"

"Certainly not," said the chief counselor. "Who ever saw a man as tall as you are?"

"Then I 'll fight and conquer them!" declared Tollydob, rising and walking about the

"And their queen is a witch," added Tullydub, nervously. "We must not forget that!"

"A witch!" exclaimed Princess Fluff, with sudden interest. "What does she look like?"

But all shook their heads at the question, and Tullydub explained:

"None of us has ever seen her, for we have never been friendly with the people of IX. But from all reports, Queen Zixi is both young and beautiful."

"Maybe it 's the one who wanted to teach me witchcraft in order to steal my magic cloak!" said Fluff, with sudden excitement. "And when she found she could n't steal it, she went back after her army."

"What magic cloak do you refer to?" asked Tullydub.

"Why, the one the fairies gave me," replied Fluff.

"Is it of gorgeous colors with golden threads running through it?" asked the lord high general, now thoroughly interested.

"Yes," said the princess, "the very same."

"And what peculiar powers does it possess?"

"Why, it grants its wearer the fulfilment of one wish," she answered.

All the high counselors regarded her earnestly. "Then that was the cloak I wore when I wished to be ten feet high!" said Tollydob.

"And I wore it when I wished I could reach the apple," said Tellydeb.

"And I wore it when I wished that my dog Ruffles could speak," said Tallydub.

"And I wore it when I wished the royal purse would always remain full," said Tillydib.

"I did not know that," remarked Fluff, thoughtfully. "But I 'll never forget that I lent it to Aunt Rivette, and she wished she could fly!"



"THE LORD HIGH COUNSELOR DREW THE CLOAK OVER HIS SHOULDERS."

room, so that all might see where his head just grazed the ceiling.

"But you can't, general; you can't fight an army by yourself!" remonstrated Tullydub, excitedly. "And being so big, you are a better mark for their arrows and axes."

At this the general sat down rather suddenly and grew pale.

"Perhaps we can buy them off," remarked the lord high purse-bearer, jingling the purse that now never became empty.

"No, I 'm afraid not," sighed Tullydub. "Quavo the minstrel said they were bent upon conquest, and were resolved upon a battle."

"Why, it's wonderful!" cried old Tullydub. "Has it granted you, also, a wish?"

"Yes," said Fluff, brightly. "And I've been happy ever since."

"And has your brother, the king, had a wish?" Tullydub inquired eagerly.

"No," said Bud. "I can still have mine."

"Then why does n't your Majesty wear the cloak and wish that your army shall conquer the Queen of IX's?" asked the lord high counselor.

"I'm saving my wish," answered Bud, "and it won't be that, either."

"But unless something is done we shall all be destroyed," protested Tullydub.

"Then wear the cloak yourself," said Bud. "You have n't had a wish yet."

"Good!" cried the four other counselors; and the lord high general added: "That will surely save us from any further worry."

"I'll fetch the cloak at once," said Fluff, and she ran quickly from the room to get it.

"Supposing," Tullydub remarked hesitatingly, "the magic power should n't work?"

Then Fluff arrived with the cloak; and, after considering carefully how he would speak his wish, the lord high counselor drew the cloak over his shoulders and said solemnly:

"I wish that we shall be able to defeat our enemies, and drive them all from the kingdom of Noland."

"Did n't you make two wishes instead of one?" asked the princess, anxiously.

"Never mind," said the general; "if we defeat them it will be easy enough to drive them from our kingdom."

The lord high counselor removed the cloak and carefully refolded it.

"If it grants my wish," said he, thoughtfully, "it will indeed be lucky for our country that the Princess Fluff came to live in the palace of the king."

The queen formed her men into a line of battle facing the army of Nole, and they were so numerous in comparison with their enemies that even the more timorous soldiers gained confi-

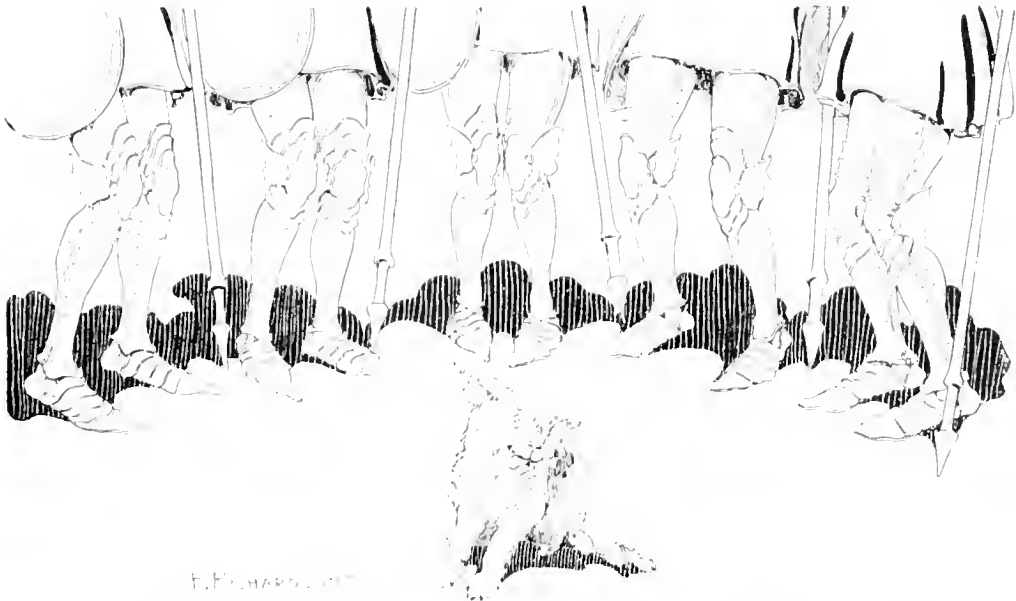

F. F. HARRIS, D.D.

"AND KEELES WOULD PLEASE TO BE AVOIDING HIS NOSE WITH HIS LEFT HAND TO THE" (SEE PAGE 577)

"Oh, but it will!" answered the general. "I'm sure it will," said the steward. "I know it will," declared the purse-bearer. "It cannot fail," affirmed the executioner; "remember what it has already done for us!"

dence, and stood up straight and threw out their chests as if to show how brave they were.

Then Queen Zixi, clad in her flashing mail and mounted upon her magnificent white charger, rode slowly along the ranks, her white

plume nodding gracefully with the motion of the horse.

And when she reached the center of the line she halted, and addressed her army in a voice that sounded clear as the tones of a bell and reached to every listening ear.

"Soldiers of the land of Ix," she began, "we are about to engage in a great battle for conquest and glory. Before you lies the rich city of Nole, and when you have defeated yonder army and gained the gates you may divide among yourselves all the plunder of gold and silver and jewels and precious stones that the place contains."

Hearing this, a great shout of joy arose from the soldiers, which Zixi quickly silenced with a wave of her white hand.

"For myself," she continued, "I desire nothing more than a cloak that is owned by the Princess Fluff. All else shall be given to my brave army."



"THE LORD HIGH EXECUTIONER

"But — suppose we do not win the battle?" asked one of her generals, anxiously. "What then do we gain?"

"Nothing but disgrace," answered the queen, haughtily. "But how can we fail to win when I myself lead the assault? Queen Zixi of Ix has fought a hundred battles and never yet met with defeat!"

There was more cheering at this, for Zixi's words were quite true. Nevertheless, her soldiers did not like the look of that silent army of Nole standing so steadfastly before the gates and facing the invaders with calm determination.

Zixi herself was somewhat disturbed at this sight, for she could not guess what powers the magic cloak had given to the Nolandars. But in a loud and undaunted voice she shouted the command to advance; and while trumpets blared and drums rolled, the great army of Ix awoke to action and marched steadily upon the men of Nole.

Bud, who could not bear to remain shut up in his palace while all this excitement was occurring outside the city gates, had slipped away

from Fluff and joined his gigantic general, Tollydob. He was, of course, unused to war, and when he beheld the vast array of Zixi's army he grew fearful that the magic cloak might not be able to save his city from conquest.

Yet the five high counselors, who were all present, seemed not to worry the least bit.

"They're very pretty soldiers to look at," remarked old Tollydob, complacently. "I'm really sorry to defeat them, they march so beautifully."

"But do not let your kind-hearted admiration for the enemy interfere with our plans," said the lord high executioner, who was standing by with his hands in his pockets.

"Oh, I won't!" answered the big general, with a laugh which was succeeded by a frown. "Yet I can never resist admiring a fine soldier, whether he fights for or against me. For in-

SUDDENLY STRETCHED OUT HIS LONG ARM, AND

stance, just look at that handsome officer riding beside Queen Zixi — her chief general, I think. Is n't he sweet? He looks just like an apple, he is so round and wears such a tight-fitting red jacket. Can't you pick him for me, friend Tellydeb?"

"I'll try." And the lord high executioner suddenly stretched out his long arm, and reached the far-away general of Ix, and pulled him from the back of his horse.

Then, amid the terrified cries that came from the opposing army, Tellydeb dragged his victim swiftly over the ground until he was seized by the men of Nole and firmly bound with cords.

"Thank you, my friend," said the general, again laughing and then frowning. "Now get for me that pretty queen, if you please."

Once more the long arm of the lord high executioner shot out toward the army of Ix. But Zixi's keen eyes saw it coming, and instantly she disappeared, her magical arts giving her power to become invisible.

Tellydeb, puzzled to find the queen gone, seized another officer instead of her and dragged

him quickly over the intervening space to his own side, where he was bound by the Nolanders and placed beside his fellow-captive.

Another cry of horror came from the army of IX, and with one accord the soldiers stopped short in their advance. Queen Zixi, appearing again in their midst, called upon her wavering soldiers to charge quickly upon the foe.

But the men, bewildered and terrified, were deaf to her appeals. They fled swiftly back over the brow of the hill, and concealed them-

his seven thousand seven hundred and seventy-seven men out of the city gates and formed them in line of battle on the brow of a hill. Then he asked Aunt Rivette to fly over the top of the mountain and see where the enemy was located.

The old woman gladly undertook the mission. She had by this time become an expert flier, and, being proud to resemble a bird, she dressed herself in flowing robes of as many colors as a poll-parrot could boast. When she mounted into the air, streamers of green and



REACHED THE FAR AWAY GENERAL OF IX, AND PULLED HIM FROM HIS HORSE.

selves in the wooded valley until the sun set. And it was far into the night before Queen Zixi succeeded in restoring her line of battle.

CHAPTER XIV.

THE ROUT OF THE ARMY OF IX.

THE next day was a busy one in the city of Nole. The ten-foot lord high general marched

yellow silk floated behind her in quite a beautiful and interesting fashion, and she was admired by all beholders.

Aunt Rivette flew high above the mountain-top, and there she saw the great army of Queen Zixi climbing up the slope on the other side. The army also saw her, and stopped short in amazement at seeing a woman fly like a bird. They had before this thought their queen sure of vic-

tory, because she was a witch and possessed many wonderful arts; but now they saw that the people of Noland could also do wonderful things, and it speedily disheartened them.

Then all the soldiers would look around to see who had spoken these fearful words, but could see nothing but a little dog; and Ruffles would pretend to be scratching his nose with his left hind foot, and would look so innocent that they never for a moment suspected he could speak.

"We are surrounded by invisible foes!" cried the soldiers; and they would have fled even then had not Queen Zixi called them cowards and stubbornly declared that they only fancied they had heard the voices speak. Some of them believed her, and some did not; but they decided to remain and fight, since they had come so far to do so.

Then they formed in line of battle again and marched boldly toward the army of Noland.

While they were still a good way off, and the generals were riding in front of their soldiers, the lord high executioner suddenly stretched out his long arm and pulled another general of Ix from his horse, as he had done the day before, dragging him swiftly over the ground between the op-

posing armies until he was seized by the men of Nole and tightly bound with cords.

The soldiers of Ix uttered murmurs of horror at this sight, and stopped again.

Immediately the long arm shot out, and pulled another general from their ranks, and made him prisoner.

Queen Zixi raved and stormed with anger; but the lord high executioner, who was enjoying himself immensely, continued to grab officer after officer and make them prisoners: and so



"THE GIGANTIC TEN-FOOT GENERAL OF THE ARMY OF NOLE STEPPED IN FRONT OF HIS MEN."

Zixi ordered them to shoot a thousand arrows at Aunt Rivette, but quickly countermanded the order, as the old woman was too high to be injured, and the arrows would have been wasted.

When the army of Ix had climbed the mountain and was marching down again toward Nole, the lord high steward sent his dog Ruffles to them to make more mischief. Ruffles trotted soberly among the soldiers of Ix, and once in a while he would pause and say in a loud voice:

"The army of Noland will conquer you."

far there had been no sign of battle; not an arrow had been fired nor an ax swung.

Then, to complete the amazement of the enemy, the gigantic ten-foot general of the army of Nole stepped in front of his men and waved around his head a flashing sword six feet in length, while he shouted in a voice like a roar of thunder, that made the army of Ix tremble.

mountain-top and down the other side and then scattering in every direction, each man for himself and as if he feared the entire army of Noland was at his heels.

But it was n't. Not a soldier of Nole had moved in pursuit. Every one was delighted at the easy victory, and King Bud was so amused at the sight of the flying foe that he rolled on the



"BUD WAS SO AMUSED AT THE SIGHT OF THE FLYING FOE THAT HE ROLLED ON THE GROUND IN LAUGHTER."

"Forward, soldiers of Noland—forward! Destroy the enemy, and let none escape!"

It was more than the army of Ix could bear. Filled with terror, the soldiers threw down their arms and fled in a great panic, racing over the

ground in laughter, and even the fierce-looking General Tollydob grinned in sympathy.

Then, with bands playing and banners flying, the entire army marched back into the city, and the war between Noland and Ix was over.

(To be continued.)



A MAY-DAY PARTY

RIDDLES IN RHYME.

I know a very ancient game
 Now see if you can guess;
 Its name begins with C H E
 And ends with double S .

The horseman, the parson,
 The king and his wife,
All went to battle
And fought for dear life.
The dwarfs ran ahead
But the king was afraid
And back of his castle
He prudently stayed;
Till a horseman came jumping
Right over the house,
And caught the poor king
In a trap like a mouse.

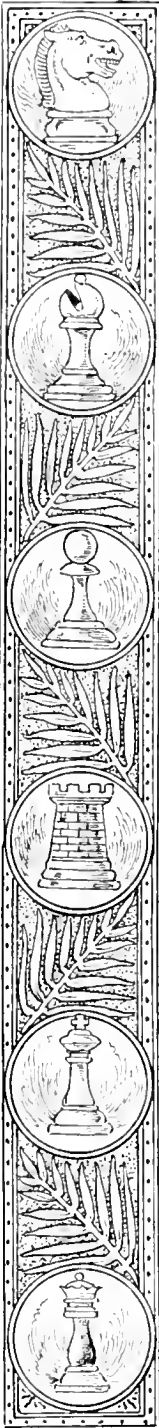

TWO FUNNY FRENCH BEARS.

BY MEREDITH NUGENT.

I WONDER what Bruin thought of it all. For years he had looked up at just such little girls; and now one was actually in the same pit with himself. True it was smaller than the children

countenance as he held the wax figure within a few inches of his nose brought shrieks of laughter from the onlookers above, and no one enjoyed the fun more than the baby boy who had accidentally dropped the doll in the first place. Nurses lifted their little tots higher that they might get a better view, and larger children squeezed between the French, English, and American visitors who always flock to this famous Jardin des Plantes, and who now thronged to this bear-pit especially. Their exclamations and merriment did not disturb Bruin though, for he was too much interested in his new-found possession. Sometimes he held it in both paws, sometimes he clasped it in one bear arm as shown in the picture. It was too little a child to hug even if he had wished to do so, and he

must have wondered why it did not cry out, or kick, or bite, or make some sort of resistance. Plainly, if ever a bear was puzzled that bear was. If he thought it a little human cub, — and I should not be surprised if that is just what he did think, — he must have had a mighty poor opinion of all those grown-up creatures above who would not risk their lives to save the little one. Accidentally his nose tilted the stylish hat off, and when, some few minutes later, his huge paw as unintentionally knocked off that curious cub's head so that the sawdust came streaming out, I wondered, indeed, what he could have thought of it all. Now

who usually peeked through the railings; but then it was finely dressed, and had long flowing hair, and eyes, nose, and mouth, too, just like other children. The comical expression of his

do you suppose he thought, as he glanced up at all those laughing people leaning far over the railing, that, because they looked like the doll, they were stuffed with sawdust, too?



AN UNEXPECTED VISITOR.

There was another bear in this same Jardin des Plantes in Paris, a roly-poly, rollicking sort of bear, that gave an exhibition of such apparent intelligence that I have never seen it equaled by any bear since, and but rarely by any other animal before that time. It was just after feeding-time and most of the animals were dozing, when we heard noises down at the farthest of the inclosures, and knew at once that the little bear was cutting up capers again. This time he had a large marrow-bone which must have contained some unusually choice morsel, for the antics he indulged in to get at this would have done credit to a circus clown. He tipped it up and he tipped it down, and he turned it all sorts of ways. He poised it over his upturned head as if in some vain hope that the contents might accidentally drop into his mouth. Then he would leave it altogether and amble curiously around the cage or play with the wooden ball. His mind did not leave it, however, for he would constantly return to the old performance. In his eagerness he would roll clear over and fall into the most ludicrous positions, as though the more ridiculous an object he made of himself, the better his chances would be to get that marrow. Once he nearly rolled a back somersault and actually did balance himself on the back of his neck, with one end of that bone held between his hind feet, and the other pointing to his open mouth below. Then he carried it to the little water-tank, but it dropped to the floor instead of into the water, as he evidently intended it should. He picked it up and dropped it again and again, but somehow his clumsiness always foiled him of his purpose, whatever that purpose was. At last he succeeded; and now that the bone was in the

water he sucked on the projecting end of it with all his might. The result of this was that the much-sought-after morsel was drawn up into his mouth with the water.

Did that little bear know that by drawing water through the bone he would probably get the morsel he so much



BRUN AND THE MARROW-BONE.

desired? This was the question we all asked ourselves. But no one could answer it.

For aught we knew, it might have been an old trick of his, learned years ago as a result of one of those lucky accidents which the history of invention tells us sometimes fall to the lot of the greatest human discoverers.

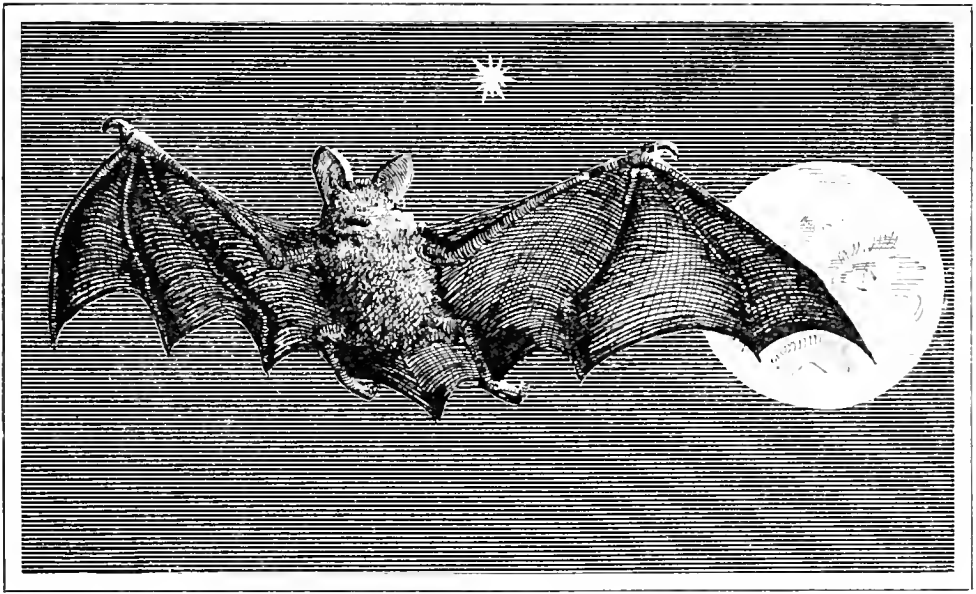

THE BAT: A FABLE.

By H. P.

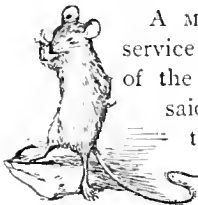

A MOUSE, one time, rendered a service of some importance to one of the eagles of Jupiter. "Ask," said the grateful bird, "anything that you desire, and in the name of my master, Jove, I promise to grant it to you."

"Oh, sir," said the mouse, eagerly, "I have long felt the mortification of living among such vulgar creatures as the beasts, and have ardently desired to associate with the more refined society of the birds. If you could but grant me wings, my happiness would be complete."

"Consider well what you ask," said the eagle, gravely. "Nature has placed you in a certain grade of society, and you need not hope that *wings* alone will make you a bird."

"I have considered the matter thoroughly," said the mouse, "and feel certain that if I

had but wings I could at last associate with those I have so long envied and admired."

"Very well," said the eagle; "be it so!" and, instantly, wings springing from the mouse's shoulders, the first bat was created.

His ambitious desires, however, were not realized; for the birds, perceiving that he still had ears and a tail and was, besides, covered with hair, would not associate with him, while, upon the other hand, his own pride had withdrawn him from his old companions.

"Alas!" said the poor, lonely animal, "why was I not contented with the humble sphere that nature intended me to fill? My very wings, that I hoped would be my pride, now prevent me from walking upon the ground, where I belong."

So mortified and disappointed was he that thenceforth he ventured out into the world no longer by daylight, but only at night, when all other creatures had retired.



PINKEY PERKINS: JUST A BOY.

BY CAPTAIN HAROLD HAMMOND, U. S. A.

IV. HOW PINKEY DELIVERED AN ADDRESS.

CHILDREN'S DAY at the church was drawing near, and each day Pinkey Perkins was becoming more and more impressed with a sense of his personal importance. He had been selected to deliver the "Welcome Address to the Fathers and Mothers" on that occasion. When he had been informed of the fact in the beginning, he had not looked on it with favor. Heretofore his oratorical efforts had been confined to the school-room, and he lacked the necessary confidence to attempt such a courageous feat. But his mother had been assured by the lady who consulted her on the subject, that the committee had carefully considered all the boys available for the honor, and had decided that of all these Pinkey was the one to make the address.

When the task had been turned over to him and he had set about practising, it was with a pardonable air of superiority that Pinkey, on occasions, when invited to join in some after-school game of "scrub" or take part in an attack on some newly discovered *bumble-bees'* nest, would reply, with a sort of bored air: "I wish I could, but I've got to go and rehearse."

True, there were others who had "to go and rehearse," but not in the way that Pinkey did. While they devoted their time to singing and went to practise collectively, he went alone to Miss Lyon, his Sunday-school teacher. That lady, being a teacher of elocution, had taken the task of drilling Pinkey in the most effective delivery for his first public oration.

"Humph! You need n't feel so smart," retorted Bunny Morris one day when Pinkey had referred rather loftily to "my address"; "you're not the only one who has to practise."

It happened that Bunny was one of eight who were to sing in chorus on Children's Day, and, although he would not admit it, the fact that Pinkey had been selected to make the "Welcome Address" rankled in Bunny's bosom.

When Bunny had made this stinging remark, Pinkey merely replied in his condescending way: "I don't 'practise.' I rehearse."

Pinkey had really entered on his work with a will, and a week before the eventful Sunday he had committed the whole of his address to memory and could recite it perfectly.

This statement, however, must be slightly modified. Sometimes, in rehearsing, he would have difficulty with certain portions of it, and that difficulty came about in this way:

Once in two weeks Miss Vance, Pinkey's school-teacher, required one half of her pupils to "recite a piece," either prose or poetry. For Pinkey's part in one of these bi-weekly punishments, as they were looked upon by the pupils, she had assigned him "The Supposed Speech of John Adams." Pinkey had surprised her by acquitting himself with credit on the occasion, for he had spent hours and days of careful preparation on it—"just to make her think it was easy," as he expressed it.

For some time, Red Feather, as she was known among her pupils, had not made Pinkey's school-life a bed of roses. Since one memorable Monday morning, when she had found four able-bodied mice secreted in her desk, she had always felt certain that he was responsible for their presence. From that day, the examples hardest to work, the States hardest to bound, and the words hardest to parse, according to Pinkey's standard, had fallen to his lot. It was to this "partiality" that Pinkey attributed his assignment of the "Supposed Speech."

Now, the author of the "Welcome Address," when in search of suitable material for that literary effort, had evidently used as a reference-work "Great Speeches of Great Men," wherein was printed "The Supposed Speech of John Adams." Owing to this fact, several portions of the "Supposed Speech," either word for word

or slightly modified, had found their way into the "Address." Oratorical flights were scattered all through it, such as: "Let not those beneath these vaulted roofs, within these hallowed walls, upon this memorable occasion, forget the incontestable vital truth that it is the young blood, the young mind, that we look to for our support," and so forth—sentiments more appropriate to John Adams's speech than to a Children's Day address.

In rehearsing, Pinkey found it hard not to confuse the two orations. In fact, neither was to him much more than a series of high-sounding phrases, intended more to impress the ear than to enlighten the mind. This is why it is necessary to modify the statement that Pinkey knew his address perfectly a week before the date appointed for its delivery.

As a reward for his diligence, Pinkey's mother promised him what had long been his heart's desire—a pair of patent-leather shoes that laced up the front and had sharp-pointed toes increased in fancy-edged tips.

Besides, since his unfortunate experience on the way home from Red Feather's party, he felt that he had been continually losing ground with his Affinity, and he hoped that the possession of a pair of patent-leather shoes might turn her in his favor.

Eddie Lewis, his arch-rival for her affections, had been paying her marked attention of late, and to Pinkey it seemed that she regarded these attentions as more or less acceptable.

Pinkey felt that the important moment when his Affinity must choose once and for all between him and Eddie would be when he should appear on the rostrum and, by his manly bearing and glowing oratory, win everlasting approval or disapproval. Consequently, he set great store by the promised shoes, which he felt would be not a small factor in making his appearance all that could be desired and thereby serve as an aid in fanning back to life the waning affections of his Affinity.

Saturday evening came at last, and, to Pinkey's delight, he was allowed to go down-town with his father and try on the coveted shoes, and to carry them home. He insisted on putting them on again when he got home, just to show his mother how well they fitted him and

how far superior they were to anything he or any of the boys had ever had before, and how high the heels were and how bright and shiny the toes. And Pinkey was doubly proud of them on account of the squeak that accompanied each step. Before he went to bed, he carefully wrapped them up again and replaced them in their box, in order that no speck of dust might get on them and mar the luster that he depended on to melt the heart of his Affinity.



PINKEY ADMIRES HIS PATENT-LEATHERS.

As he lay in bed that night, reciting his address over and over, and making his gestures in the darkness, he pictured the envy of the others as they saw him in his new shoes mount the platform to declaim his welcome. He had said nothing to any one about the shoes his mother had promised him,—not even to Bunny,—and he looked forward to the envy they would arouse among his less fortunate companions.

When Pinkey awoke next morning, it was raining; but no rain could dampen his spirits on such an occasion as this. He wore his ordinary "Sunday shoes" to Sunday-school that morning, desiring not to show his patent-leathers until the time came for his address.

On account of the rain and mud, Mrs. Perkins suggested that it might be better not to wear the new shoes to the exercises; but Pinkey could not think of such a blow to his plans, and his mother had not the heart to wound his pride

by insisting on her suggestion, and, besides, she feared he might not do so well with his speech if he were plunged into disappointment after all his anticipations.

"Pinkey," said his mother, after putting the last finishing touches to his toilet, "since you *must* wear your new shoes in all this rain and mud, I want you to put on these high overshoes of mine, to keep your shoes clean."

To this compromise Pinkey reluctantly assented, but later found his action to be a wise one, as he encountered the muddy crossings on the way to church, against which his own rubbers would have been but little protection.

Pinkey's heart swelled with pride as he strutted along between his father and mother on the way to the church. But as he saw the people entering the building, several of whom spoke encouraging words to him about his forthcoming address, he began to feel a little shaky and noticed his heart beating faster than he liked. He kept trying to swallow a lump of suppressed excitement that would go neither up nor down.

If Pinkey gave these symptoms more than a passing thought, he attributed them to his inward exultation and not to any manifestation of stage-fright—a malady of which, up to that time, he had never known the existence.

Pinkey left his parents at their pew and marched on up the carpeted aisle, looking neither to right nor left. He mounted the rostrum and took his seat on one of the uncomfortable, high-backed, hair-cloth chairs which, since time immemorial, had occupied space at either end of the equally uncomfortable, though not so high-backed, hair-cloth sofa on the platform. The top of the seat was rounded in form, and Pinkey found it hard to retain his position and his composure at the same time.

As the time drew near for the exercises to begin, Pinkey became more and more nervous. The church became full to overflowing, despite

the bad weather, and, look where he would, Pinkey found hundreds of eyes gazing at him. He envied those in the chorus, because they each had seven others to assist in the singing, but he must get up and do his part all alone.

Presently the minister appeared and attempted to put the children at their ease by shaking hands with each one and uttering a few words of encouragement.

The members of the chorus were seated on a long bench on one side of the rostrum, and were partly hidden by the banks of flowers, while Pinkey sat alone on the other side, out in full view of the congregation, where he could get only an occasional, uncertain view of the



PINKEY REHEARSES IN BED—“RECITING HIS ADDRESS OVER AND OVER, AND MAKING HIS GESTURES IN THE DARKNESS.”

others. His Affinity was there, but he could not muster up the courage to look at her.

He tried to look unconcerned, but he knew the utter failure he was making. Once he saw Putty Black grin and whisper something behind his hand to the girl next to him, and then they both looked at Pinkey and tittered.

By and by the last bell stopped ringing and the exercises began. By the time the chorus had sung the “Welcome Carol,” and the minister had made the opening prayer, Pinkey had partly regained his composure. But the minis-

ter's reference to the "bright young faces" around him, and the pleasure he felt and that he was sure every member of the congregation must feel "on such an occasion," made the

Then he began. Automatically the words came, but his voice sounded hollow and strange. His throat was parched, and it was with difficulty that he could get his breath. The roaring in his

ears made his voice sound as though it came from far in the distance. The perspiration stood in beads on his forehead, and he felt hot and cold by turns. Still on he went, though it seemed that each word must be his last.

About midway of his speech, in order to allow the full import of his words to awe his hearers, Pinkey had been taught to strike an attitude and pause for effect. Reaching that point, he paused, right hand uplifted, left foot ad-



pitapat of Pinkey's heart seem to him loud enough to drown all other sounds.

After a few other appropriate remarks, during which Pinkey's discomfort became more and more marked, the minister announced his "pleasure in presenting to the congregation the orator of the day," who would welcome the fathers and mothers on this joyous occasion — "Master Pinkerton Perkins."

Pinkey slid from his perch on the hair-cloth chair as the minister seated himself on the mate to it at the other end of the sofa.

With shaking knees, he walked to the front. When he stopped, his legs trembled so violently that he felt sure every one in the congregation must notice his quaking knees.

He could distinguish nothing. All before him was an indistinct blur. Beyond, at the rear of the auditorium, he could make out a hazy, arched opening. That, he knew, was the door. He looked for his mother, but his eyes would focus on nothing, and the intense stillness that pervaded the whole room only added to the suffering he was undergoing.

vanced. As he put his foot forward, a nauseating wave of sudden mortification swept over him. *Now* he knew why Putty Black had whispered to the girl next to him. *Now* he knew why they had both tittered as they looked at him. Gradually he bent his head and looked down until his gaze met his feet. The sight that greeted his eyes sickened him.

He had forgotten to take off his mother's overshoes!

The shock of this realization, combined with his stage-fright, rendered Pinkey utterly helpless. He stood as one petrified, speechless, before the assembled throng. He stared glassily at his overshoes; they seemed fascinating in their hideousness. A stir in the congregation awakened him to the fact that he had been standing mute, he knew not how long.

He tried to continue his address, but the words had taken wings. Miss Lyon attempted to prompt him, but all her efforts proved futile. He could not take up the broken thread.

Yet he dare not quit the platform with his speech unfinished and go down to ignominious

failure before the eyes of the congregation, of his father, his mother, and, above all, his Affinity.

Then came a brilliant thought. "The Supposed Speech of John Adams"! Since the two speeches were so similar, why would not that do instead of the one he could not remember?

Without further delay, he began: "Sink or swim! live or die! survive or perish! I give *my* hand and *my* heart to this vote! It is true that, in the beginning, we aimed not at Independence; but there 's a Divinity that shapes our ends—" and so on, without hesitation, clear to the end.

Delivering his school-room speech, he regained his school-room composure, and as he spoke he gathered courage. His voice became natural and his lost faculties, one by one, returned. His knees became firm again, and his heart became normal. What had been but a hazy blur became a sea of faces, and all within the church began to take definite form.

As Pinkey concluded, he made a sweeping bow, once more possessed of all his customary assurance.

Spontaneously the congregation burst into applause, such as the old walls had never heard on any occasion. Every one had seen his overshoes, and had been moved to sympathy when they saw his embarrassment on discovering them. That he had left out part of his address, which he had plainly forgotten, and delivered another entirely out of keeping

with his subject and the occasion, only increased their admiration for his determination and grit.

With his head erect, Pinkey faced about and returned to his chair. As he did so he gave a look of triumph at his Affinity, and received in return a look that told him, plainer than words, that, overshoes or no overshoes, he had won her unqualified approval.

When he reached his place, he knelt down,



PINKIE DIS-OVERS HIS OVERSHOES.

calmly removed the overshoes, and, with his heart swelling with pride at the ringing applause, resumed his seat on the hair-cloth chair.

THE BLUEBIRD.

BY SILAS A. LOTTRIDGE.



A GENTLE south wind has been blowing at intervals for a week, the snowbanks are diminishing in size, and here and there the brown earth seems to be pushing itself up from beneath. The sun has loosed the ice fetters, and again the murmur of the brook is heard; over the water the pussy-willows are hanging their swollen buds; and out in the grove the sap is beginning to drop from the maple-trees. These are signs of spring, indeed! Now it is time to listen for the note of the bluebird. A plaintive note it is at first, but it will soon give place to a pleasing song, never loud, but always sweet and altogether suggestive of the warblers.

How welcome it is—that bit of blue and brown flitting among the yet naked boughs of the old apple-trees! We look for the bluebird in spring with a feeling different from that for any other bird during the whole year. His note awakens within us the assurance of the quick return of the spring-beauty and wake-robin and of a whole troop of songsters.

In a day or two Lady Bluebird will arrive—a very modest little woman, with less brightly colored plumage than her lord's, and more retiring manners. Now, if you are patient, you will have an opportunity to observe a most interesting courtship. Mr. Bluebird is an attentive lover, exhibiting to his lady all the charms of his beautiful plumage, singing to her his sweetest songs, and feeding her with the choicest bits of food to be found. In actual bird life it sometimes happens that a rival will appear upon the scene, and then there are many contests with voice and beak until one or the other is vanquished. After this the courtship proceeds smoothly, and before long the birds begin to look about for a suitable place for

house-keeping. The "bird-boxes" and small cavities in trees are carefully inspected, and when a spot is found to their liking, a nest is quickly made if the birds are not interfered with in their work. The house-wrens, and especially the English sparrows, are their greatest enemies, and often attempt to drive the bluebirds away. But when once settled they are very determined, and usually succeed in maintaining their own. However, year by year they are becoming less numerous about our dwellings on account of the English sparrows.

In my bird note-book I find a sketch of the bluebird families that have occupied a bird-box for several years in succession. The box was erected against the side of a large tree that stood in the rear of the house. It consisted of a hollow limb about twenty inches long and six inches in diameter, closed at the top and bottom, and having a hole in one side. On another side was a door, through which the nest and contents could be inspected. It was placed about ten feet from the ground and connected with a microphone, and a line joined it to a telephone receiver in the house. A microphone is to the ear what the microscope is to the eye; it consists of loose pieces of carbon so arranged as to magnify any near-by sound, just as a lens magnifies an image in a microscope.

I did not expect to obtain results that could any more readily be turned into words than can the notes of the veery, or the singing of a mountain stream; but I wanted to hear the notes of the old birds and their young when undisturbed by man, and this was the only method known to me of accomplishing the desired end.

When the arrangements were completed, I waited for the house to be occupied. By March 20 it had been inspected by many bluebirds, but none had decided to remain. Through the apparatus I had the pleasure of

listening to bluebird conversations such as I had never heard before. As the birds were house-hunting, their notes at times were very



THE "BOX" WITH THE "DOOR" REMOVED, SHOWING THE MICROPHONE AND CONNECTIONS

spirited, and their quick movements were plainly indicative of their excitement.

The first week in April, after a very careful inspection of the house, inside and out, a pair of bluebirds decided to remain. They commenced the nest at once, using fine grass as material. The sounds of their building could be heard very distinctly through the telephone receiver. The third day a great commotion was announced over the line, and on investigation I found that some English sparrows were trying to turn the bluebirds out. After two days of disturbance the bluebirds were victorious, but the male bird kept a very careful watch about the box for several days; and he proved himself to be a veritable "blue streak" to every English sparrow that came within a hundred feet of his home.

In due season the nest was finished, and on April 23 there were five eggs. By May 7 all the eggs were hatched. The peeping of the

little birds and the quieting notes of the mother could be plainly heard through the receiver. The notes varied greatly in pitch and quality. The mother bird used certain notes that the little ones appeared to answer, just as chickens will respond to certain sounds and movements of the hen. A certain note from the mother hen will call the chickens, while another will send them immediately to cover if a hawk appears in the sky.

When the mother bluebird was in the nest and the little ones were making a noise, if some one carefully approached the tree and scratched on the bark, the mother would give one low note and all would immediately be quiet. Each repetition of the experiment called forth the same low note.

This naturally leads to the query: Is this true of other birds as well? I believe it is.



THE "BOX" WITH THE "DOOR" CLOSED

It is a fact that the ruffed grouse does it, and there is every reason to believe that all birds have some sort of language of their own.

The old birds of this family early became very tame. On the ninth day after the young were hatched, the female must have been killed, for she disappeared on that day and was not seen again. This tragedy seemed to discourage the male, and seeing that the young were in danger of starving, we took them into the house and brought them up by hand. They became great pets, and after they could fly about the yard they would come for their food several times a day. They remained until August 15, and after that I was not sure that I saw them again, for one bluebird looks very much like another.

In late summer the song of the bluebird is changed to a plaintive note that is as suggestive of coming winter as the song is of returning spring. At this season of the year, and especially in autumn, it is usual to see small flocks of them along the roadsides and about

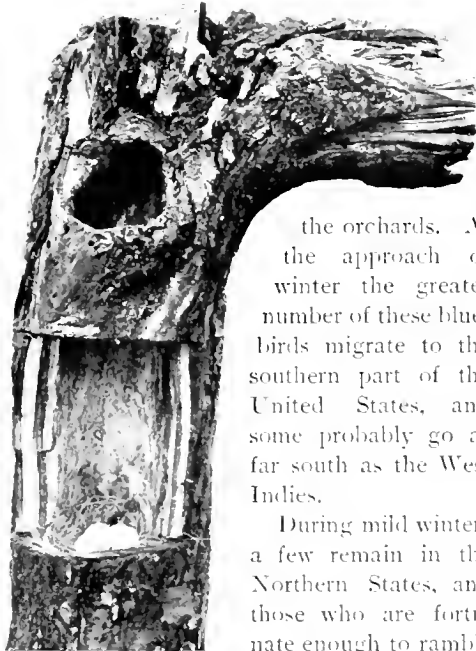

THE NEST WITH "DOOR" REMOVED, SHOWING THE EGGS.

the orchards. At the approach of winter the greater number of these bluebirds migrate to the southern part of the United States, and some probably go as far south as the West Indies. During mild winters a few remain in the Northern States, and those who are fortunate enough to ramble about the hedges and byways find them in sheltered places. On pleasant days, too, they are sometimes seen in the open fields among the brown weeds, eagerly searching for the few seeds that the wind shakes from the pods still above the snow; or occasionally they may

even be found flitting about the haystacks near the barns, where the cattle are fed in pleasant weather.

One January morning I saw a very unusual bird-picture about one of these stacks. The



THE NESTINGS.

ground was covered with a thick blanket of snow, over which the hay had been scattered. The loosened seeds were tempting bits of food for the hungry wild birds, and as the morning grew warmer a flock came from the thick underbrush of the woods near by. The greater number were snowflakes, but there were a few sparrows and five bluebirds. On nature's

white background the blue of the bluebirds, the gray of the sparrows, and the brown and white of the snowflakes made indeed a very pleasant variety of color and contrast.

The sweet disposition and gentle, lovable ways of the bluebird are evident even in captivity. In the summer of 1898 I had the pleasure of carefully studying the habits of old and young in that condition. The old birds were kept in a large bird-room with several other varieties of American birds. The bluebirds were models of good behavior, not only among their own kind, but in their relations with other birds. The young birds were kept in cages, and with a moderate amount of care and attention became very tame. It was amusing to see them, about the usual feeding-time, arrange themselves on a particular perch. Each bird in order of precedence would take the food from a stick, and if one was purposely omitted there was no fluttering of wings or selfish attempt to obtain the morsel as it was offered to the next bird.

These unselfish table manners I have observed as well in wild bluebirds. Several years ago a pair of bluebirds selected as a home the

deserted winter quarters of a downy woodpecker. The cavity was located in the dead branch of a cherry-tree which stood in the yard in the rear of the house. On the seventh day after the young were hatched a severe wind-and-rain storm so broke and split the old stub that the young were in danger of perishing. We soon converted a small basket into a comfortable nest for the unfortunate family; and from a second-story window of the house we watched the birds unobserved. The old birds accepted the situation and continued to feed and care for the young. As the food was brought there was no strife on the part of the young birds, but each waited his turn. This continued not only while the young were in the nest, but until they flew away.

The bluebird makes a very playful and affectionate little pet. Mr. A. Radclyffe Dugmore tells of a very interesting one he possessed. "While I am writing," he says, "a pet one, but three months old, is sitting on my paper, seeming to wonder what I am doing and why I do not play with him. He nips my pencil, but I pay no attention to him; then he tries to creep up my sleeve, and still I pay no attention; so, disgusted, he flies off in search of ants or other small insects. After a time I raise my hand and call; back he comes,



THE BLUEBIRD OFTEN CHOOSES A HOLE IN AN OLD FENCE-POST FOR HIS NEST.

like a flash, and, hovering, more like a large moth than a bird, he perches on my finger, singing at the same time a soft little song that is his method of speech."

"HANDSOME IS AS HANDSOME DOES."



"COME, PAPA, TAKE OUR PHOTOGRAPH! YOU PROMISED ME YOU WOULD
MY DOLLY'S NOT SO BEAUTIFUL; BUT THEN, YOU KNOW, SHE'S GOOD."

HOW TO STUDY PICTURES.

BY CHARLES H. CAFFIN.

A series of articles for the older girls and boys who read "St. Nicholas."

SEVENTH PAPER.

COMPARING HOBBEEMA WITH CLAUDE LORRAIN.



"THE AVENUE," OR "THE ROAD TO MIDDELHARNIS," BY MEINDERT HOBBEEMA

MEINDERT HOBBEEMA (BORN 1638?, DIED 1709); CLAUDE LORRAIN (BORN 1600, DIED 1682).

THE village of Middelharnis, in Holland, is one of the places that lay claim to be the birth-place of Hobbema, the town of Koeverden and the cities of Haarlem and Amsterdam being the others. And this picture, "The Avenue," gives us a clear idea of the approach to Middelharnis as it appeared in the late sum-

mer of 1680, when Hobbema is supposed to have painted it. It is a portrait of a bit of nature, whereas Claude's picture—you might guess it from the title, "Landing of Cleopatra at Tarsus"—illustrates the use of nature to build up an imaginary composition; the borrowing from many sources, and the arrangement of the details to produce a scene which the artist's imagination has conceived to be ideally beautiful.

We ought to be able to enjoy the one and

the other, but we do not feel toward both in the same way. It is very probable that we shall begin by preferring the Claude. It so, it is largely because the lines and masses of its composition are more pleasing. The hulls, masts, and spars of the shipping on one side balance the lines of the architecture on the other, and between them is a gently dipping curve which separates the luminous open space of the sky from the glittering waves of the water and the busy animation of the figures. Besides the actual beauty of balance between the

and hardly care to distinguish which of the figures is Mark Antony's. Our feeling is that a shore which was once a ragged ending of the land, where the sea began, has been made a stately approach of terraces leading up to noble buildings; that in these, as in the shipping, man's creative power is apparent; that the scene is an improvement upon nature.

Now we turn to the Hobbema. It is a composition of vertical lines contrasted with horizontal; a much cruder arrangement of spaces—of nature unadorned, we might al-



"LANDING OF CLEOPATRA AT TARSUS," BY CLAUDE LORRAINE

full and the empty spaces of the composition, we get the added enjoyment of contrast between a sense of activity and a still stronger one of permanence and repose. Everything has been calculated to stir our imagination pleasantly. We find ourselves thinking that if there is no spot on earth like this, it is a pity; that there ought to be one, and that the artist has made it possible. In fact, he has created it—and thereby we are the happier.

We are little concerned with Cleopatra,

most say, or, at any rate, taken as the artist found it. We are disposed to feel that perhaps we are lacking in imagination, and that his work, as compared with the ideal beauty of Claude's, is homely and uninteresting; that, to use an expression of the eighteenth century, when artists prided themselves on having a "pretty fancy," it is "pedestrian"—that it does not soar, but walks afoot like the common people.

Certainly Hobbema was not inventive, like

Claude; he did not devise or try to construct an ideal Holland out of his imagination. But imagination may display itself also by its sympathy with and insight into things as they are; and it was this kind of imagination that Hobbema possessed. He loved the country-side, studied it with loving care, and has depicted it with such intimacy, or truth, that the road to Middelharnis seems as real to us to-day as it did over two hundred years ago to the artist. We see the poplars, with their lopped stems, lifting their bushy tops against that wide, high sky which floats over a flat country—full of billowy clouds, as the sky near the North Sea is apt to be. Deep ditches skirt the road, both to drain it and to collect the water for purposes of irrigation and—later on, when it has joined a deeper, wider canal—for purposes of navigation. We get a glimpse on the right of patient perfection of gardening, where a man is pruning his grafted fruit-trees; farther on, a group of substantial farm-buildings. On the opposite side of the road stretches a long, flat meadow, or "polder," up to the little village which nestles so snugly around its tall church tower; the latter fulfilling also the purpose of a beacon, lit by night, to guide the wayfarer on sea and land. A scene of tireless industry, comfortable prosperity, and smiling peace, snatched alike from the encroachments of the ocean and from the devastation of a foreign foe, by a people as rugged and as aspiring as those poplars, as buoyant in their self-reliance as the clouds. Pride and love of country breathe through the whole scene, and we may be dead to some very wholesome instincts if we ourselves do not feel drawn on the one hand toward its sweet and intimate simplicity, and on the other toward its fearless originality of composition.

Indeed, if we have entered into the spirit of it, we may find that this picture, as well as Claude's, has its ideal beauty—if by this term we understand that kind of beauty which is distinguished by the idea revealed in it. In other words, it is not only imaginary subjects which may be ideal; there may also be an idealization of the facts, so that the more their outward appearance is pictured, the more we are made to feel as well their underlying meaning—the soul, as it were, within them. In this

way a portrait may be idealized. I am not thinking, for the moment, of the kind of idealization indulged in by Van Dyck, who gave to all his sitters, men and women, an elegant refinement, corresponding to the idea of elegance and refinement in himself. That is more like the kind of idealization in Claude's picture. But let us take the case of the portrait of your own mother. One painter may paint it so that anybody, comparing it with the original, will say it is a good likeness; whereas another may have the imagination to put in something of her beauty of character, to reproduce something of what you know of her as a mother. He gets at the soul of the face.

Similarly, the portrait of a landscape may reproduce the sentiment which attracts to the country-side—the love of the painter for it, the attachment of those who live in it, what it is to them as part of their lives. Such a landscape is in a measure ideal. The modern French have coined a phrase for it,—*paysage intime*,—for which I can find no better translation than "the well-known, well-loved country-side." They coined it to describe the kind of landscape that was painted by Rousseau, Dupré, Corot, and some other French artists, who made their headquarters at the little village of Barbizon on the borders of the forest of Fontainebleau; and these men were followers of Hobbema and the other Dutch artists who had lived two hundred years before.

Very little is known of Hobbema's life. He appears to have been born at Amsterdam in 1638, but, as we have seen, other towns claimed to be his birthplace. It is probable that he was the pupil of Jacob van Ruysdael, and certain that he lived in Amsterdam. He died poor, his last lodging being in the Roosegraft, the street in which Rembrandt, also poor, had died forty years before. His works were little appreciated in Holland until nearly a hundred years after his death, and most of them found their way to England.

Claude, on the contrary, enjoyed in his lifetime a European reputation. Yet his early life was modest enough. He was born of poor parents in the little village of Chamagne, near the right bank of the Moselle, in what is now the department of Vosges, but in 1600 was the

duchy of Lorraine. His real name was Claude Gelée, but from his native country he received the name of Claude de Lorraine, or, more shortly, Claude Lorrain. As a child he seems to have been apprenticed to a pastry-cook, and when the years of his apprenticeship were completed he set off with a party of pastry-cooks to Rome. The Lorrainers were famous in this capacity, and the young Claude had no difficulty in finding employment. He was engaged by a landscape-painter, Agostino Tassi, as cook and general housekeeper, with the privilege of cleaning his master's brushes. He gained from him, however, instruction in painting, and seems to have become his assistant. When he was twenty-five years old he revisited France and stayed two years, returning then to Italy, where the rest of his life was spent. And it was a life of fame. Three popes in succession were his patrons, as were the noblest families of Italy, while commissions came to him from his native land, from the Netherlands, Germany, Spain, and even far-off England.

By the great Italian masters landscape had been used almost entirely as a background for the figures. Claude went a step further, making his figures of comparatively little importance and concentrating his effort upon the ideal or heroic character of the landscape, into which he incorporated the beauty of archi-

tecture. He was a close student of nature, sketched and painted in the open air, and filled his skies with sunshine. But the use that he made of nature was unnatural.

Not satisfied to paint nature as it is, for its own sake, as Hobbema was, Claude felt that the province of art was to improve upon it. He was one of the founders in French art of what is called the classic or academic school, which would reject everything that is "common" or "vulgar," and paint only types as near as possible to perfection. So, in the case of a landscape, the painter would select a morsel from this place, and others elsewhere, and put together out of his head a composition that should present an ideally beautiful arrangement of lines in masses. This exactly suited the taste of the time, in which the great gardens of Versailles were laid out with combination of grottoes, fountains, architecture, and landscape. The result was a popularity for Claude's pictures which extended throughout the eighteenth century and on into the following one. He was regarded as the greatest of landscape-painters. When, however, Frenchmen began to turn to nature directly, they soon discovered Hobbema's work and made it the foundation of their own efforts; carrying the truth to nature in their work even further than he did in his.



EACH LITTLE GIRL IS NEAT AND SWIFT, AND ALL ARE QUAINLY DRESSED.
HOW CAN WE CHOOSE ONE MAY-QUEEN AND LEAVE OUT ALL THE REST?
WHICH IS THE NEATEST, WHICH IS THE SWEETEST, AND WHICH DO YOU LIKE THE BEST?

IN MERRY ENGLAND.

BY LUCY FITCH PERKINS.



In merry, merry England,
In the merry month of May,
Miss Mary Ella Montague
Went out in best array.
Her wise mama called out to her,
"My darling Mary Ella,

It looks like rain to-day, my dear;
You 'd best take your umbrella!"
That silly girl she paid no heed
To her dear mother's call.
She walked at least six miles that day,
And it never rained at all!



THOUGHTS IN CHURCH.

BY LUCY FITCH PERKINS.



O'er, to be a sailor
And sail to foreign lands—
To Greenland's icy mountains
And India's coral strands!
To sail upon the Ganges
And see the crocodile,
Where every prospect pleases,
And only man is vile.

I 'd love to see the heathen
Bow down to wood and stone,
But his wicked graven image
I 'd knock from off its throne!
The heathen-in-his-blindness
Should see a thing or two!
He 'd know before I left him
What a Yankee boy can do!



A CANDY PULL AT SEA.

By C. W. K.

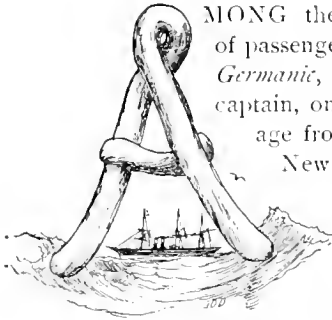

AMONG the large number of passengers on board the *Germanic*, of which I was captain, on a certain voyage from Liverpool to New York, was an American family consisting of a widow, with her two daughters and a son.

They were from one of the Western States. They sat at my table, and as the eldest daughter, a girl of sixteen, was never seasick, I had come to call her "Jack," in compliment to her good sailor qualities.

I could tell of many of the jolly happenings on that particular trip, but I will confine myself to but one, for that was something new in my experience.

On the morning of the fifth day, as I stood at the door of the wheel-house, I turned and saw a group of young girls, with Jack at their head, timidly walking in my direction. Seeing my gaze directed toward them, Jack walked up, while the others slowly followed.

"Captain," she said, "we have come to ask a very great favor of you, and we do so hope you will grant it, for I'm sure you never had such a thing on board ship before."

I smiled and said, "I must first know what it is before I can give my consent."

"Well," she said, catching her breath and looking at the girls behind her, who were now encouraged to draw a little closer, "we would so much like to have a candy pull." And now that the secret was out, she looked up with one of her bright, sunny smiles and added, "Oh, *please*, captain, say yes."

"If you will tell me what a candy pull is I shall no doubt be glad to give my consent. I have been to sea all my life, and, as you say, I never heard of such a thing on board ship."

"And we shall need the stove in the kitchen for a little while to boil it, captain," she continued, without noticing my remark.

"Oh, it's cooked, is it?" I inquired.

"Of course it is. We could n't pull it if it was n't, you know."

"No, I don't know anything about it," I replied. "It's all Greek to me. But we must first interview Professor Goff, the chief cook, before we can fully decide the question. The kitchen is his domain, and we cannot intrude without his permission."

Her face fell a little as she said: "Do you think he will object even if you say we may?"

"Let us go and see and then we can decide the matter at once."

So off we started for the galley, the girls chatting the while like magpies, though in half-subdued whispers. Arriving there, I said to the chief cook: "Mr. Goff, here are some young ladies who have a special favor to ask of you. They have my full permission, and it rests with you to accommodate them."

Jack mustered up courage to say that they would like the use of the galley stove for about two hours. It was arranged that they could have it in the afternoon, and also one of the stewards as assistant. After selecting one of the kettles and some pans, the girls left the galley, delighted with their success.

The news soon spread among the passengers, for, as you know, the most trifling incident that helps to vary the monotony of an ocean voyage is always welcome.

About half-past two that afternoon I walked quietly down toward the galley. I shall never forget the sight that met my eyes. Seven young girls enveloped in white aprons, with faces red from the heat of the stove, were flying about, all laughing and talking at once, so that I could not make out a word. One of them, in what looked like a prim Quaker dress, but with an outlandish chef's cap of white paper, was stir-

ring something in a large saucepan. Despite the fantastic costume, I recognized Jack.

There was only a slight motion to the ship that day, but the girls, who had never seen a moving kitchen, found it hard to get used to the continual rising and falling and tilting of the stove. I moved a little nearer the door, and one of the girls caught sight of me.

"Oh, there 's the captain!" she cried.

"Please don't come in yet! You won't enjoy the candy half so much if you smell the cooking."

"Have you everything you want?" I asked.

"Oh, yes; everything is just splendid. Thank you so much!" she replied.

Never before had such a scene been enacted in the galley of the old ship.

In an hour the candy was pronounced done, and Jack, with some help, lifted the heavy saucepan off the stove and rested it upon a receiving-shelf, stirring it all the while. The boiling contents were poured into pans and allowed to remain until partly cooled. It was then turned into seven platters, one portion for each girl, and carried by two of the stewards into the dining-saloon, where the "pulling" was to take place. Hearing from one of the passengers that this process was in full operation, I decided to go below for closer observation.

Jack was seated in my place at the table, with three girls on each side. To give room for their arms, vacant chairs had been left between them. All were working and pulling the snowy mass as if the safety of the ship depended upon their success.

The passengers had become so interested in Jack's scheme that they nearly all went down to the dining-saloon to encourage the happy candy-makers in their work.

After pulling for about half an hour, each girl

laid her portion in a plate before her, and the judges drew near to give their decision as to which one had produced the whitest "twist."

Seven anxious faces were raised to hear the verdict, and I confess I was pleased when Jack's piece was pronounced the whitest. And while, of course, the other girls were disappointed for a moment, they were in the end pleased, as it was because of Jack's energy that the afternoon's amusement had come off at all.

After hearing the decision I left the saloon and went up to my chart-room.

An hour later, as I sat reading, I heard a chorus of girlish voices and approaching footsteps. Glancing out of the port-hole, I saw the candy party coming toward me, evidently with the intention of making a call.

To my surprise, they brought with them a box gorgeously tied with red, white, and blue ribbons. Removing the cover, I found it to contain the result of Jack's labor. It lay embedded in silver-paper at the bottom of the box. Afterward I took it to my cabin, and I made it last not only until we reached New York, but for many a voyage thereafter.

No ship-captain, I venture to say, had ever a more winsome little passenger than our little "Jack," the charming American girl who superintended the first recorded candy pull at sea.



"STIRRING IT ALL THE WHILE."

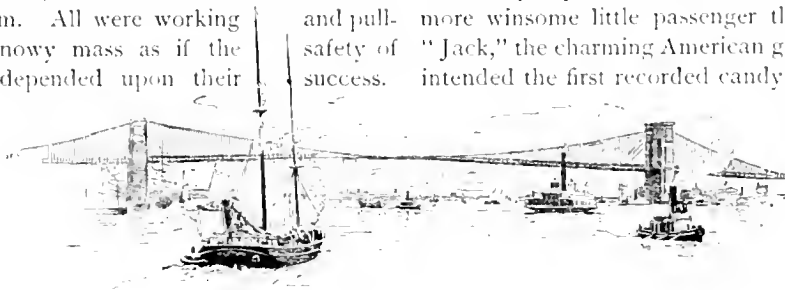

VENICE.

BY JOHN MOTT.

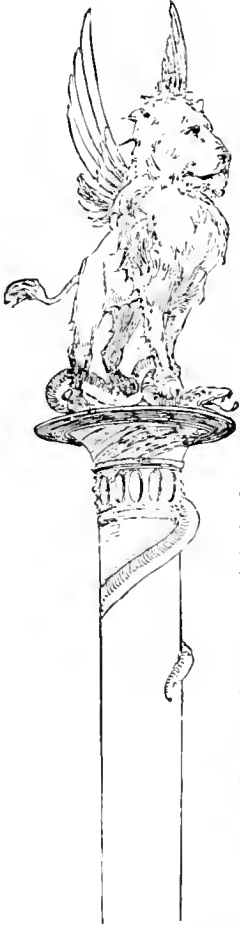

You all have heard of Venice, that curious city on the Adriatic Sea where the streets are canals and the men go from place to place in gondolas instead of in carriages. Long ago Venice was one of the wealthiest cities in the world: its great fleets brought home the merchandise of the East, jewels and silks and spices; its merchant princes built those beautiful palaces which stand to-day beside the Grand Canal, most of them sadly in need of repair, it is true, but majestic still, though the plaster is falling from their weather-beaten walls. Perhaps Venice is even more beautiful now in its decay than it was in the days of its greatest glory, for age has a beauty of its own, softer

and more delicate than that of youth. The bright colors which once shone with dazzling brilliancy under the Italian sky are now subdued and mellowed like those of an old tapestry. So, though wealth and commerce are deserting the city in the sea, its loveliness increases from year to year and attracts to it thousands of visitors from all parts of the earth; from Germany and England and America, and even from far-away China and Japan. These visitors come in the greatest numbers in the early springtime, for then the weather is best; the days are clear and fine, and the bright southern sun makes Italy warm and delightful when people in more northern countries are still shivering with the cold. So during the pleasant spring days the old square of San

Marco, the Public Gardens, and the bathing beach at the Lido are crowded with strangers, while the graceful black gondolas which dart through the narrow canals are nearly all decorated with the flags of foreign countries, among which the Stars and Stripes is not lacking.

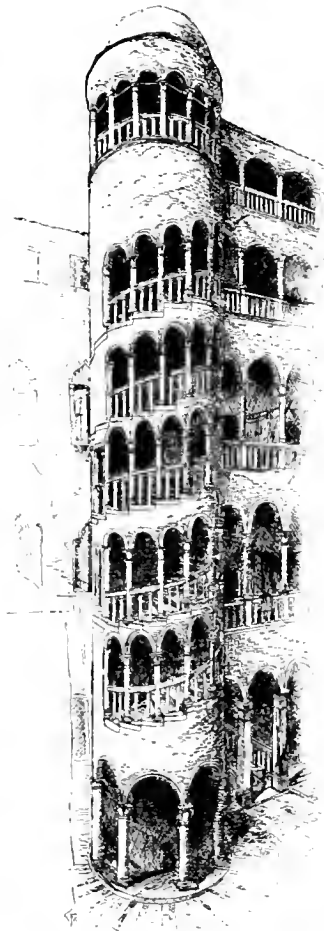

AN ANTIQUE STAIRWAY IN A PRIVATE PALACE.

But it is on a moonlight night that Venice is most beautiful. Then the lights along the quay adjoining the Doge's Palace show throngs of laughing people; the ancient mansions that line the Grand Canal seem to be gazing calmly down at their broken reflections in the dark water, and the moon rides high in the heavens above the white dome of the church of "Our Lady of Salvation." Suddenly the soft strains of sweet music fill the air. They come from a large boat, all aglow with gay colors and lanterns. It floats

along the center of the Grand Canal. The crowd on the quay cease chattering and laughing for an instant, the balconies of the hotels fill with eager



A CANAL IN VENICE.

listeners, and the fleet gondolas which have been darting about in the moonlight cluster quickly around the boat, where a boy is singing to the accompaniment of two or three stringed instruments.

The young Venetian's beautiful voice rises clear and strong on the still night air as he sings an Italian love-song. To many of his hearers his words are without meaning, but the language of music is universal; a singer needs no interpreter; so the stranger, as he leans back on the cushioned seat of his gondola, understands as

well as the native. All discordant sounds are hushed; only a faint murmur from the people on the quay, the soft rubbing of one gunwale against another as the gondolas snuggle closely together, and the lapping of the ripples mingle with the singing to make it different from any that the listener has heard elsewhere. But ever afterward, when the music of that song flashes through his memory, as music has a way of doing, he will see again the moonlight and the dark canal, the somber old palaces and the gleaming lights along the quay.

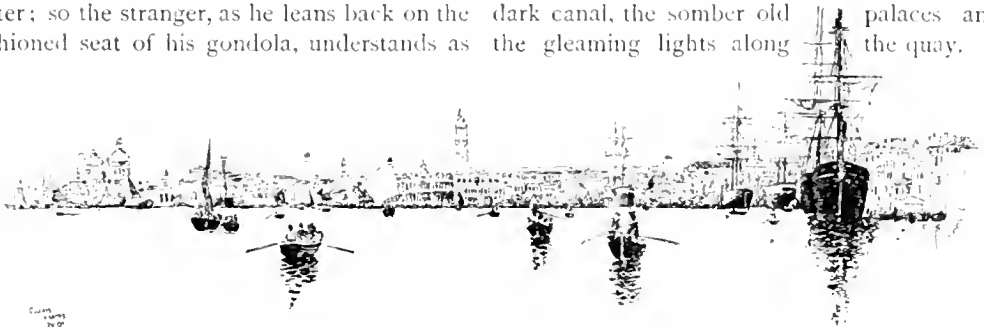

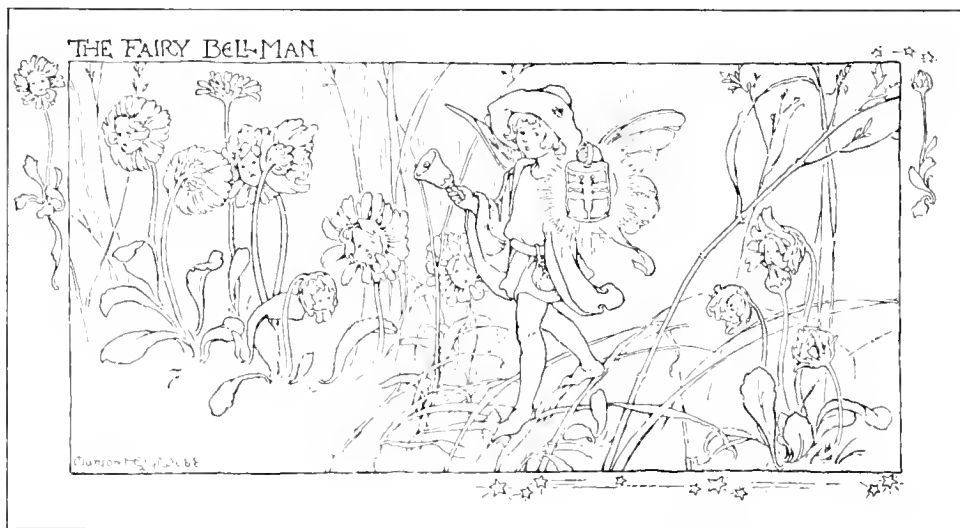

THE FAIRYLAND BELLMAN.

BY MARGARET ELY WEBB.

THE bee goes home when the shadows creep
 Across from the slope of the western hill;
 The cricket is quiet; the field is still;
 The flushed little daisies are longing for sleep.

Look! Through the grass comes a firefly light:
 'T is the fairy watchman with his bell,
 Crying, "Eight o' the clock and all is well;
 It is time that the daisies were shut up tight."

Hark! Through the field goes a sleepy sigh!
 Slowly the little white petals close;
 Wee pointed nightcaps, rows upon rows,
 Nod as the wind goes whispering by.



SUSIE AND WINNIE AND THE BALLOON.

By ALICE H. LOVIE.



SUSIE.

SUSIE and Winnie stood on the lawn watching the carriage turn the corner. Two little fists twisted into two little eyes, and the toes of two little shoes dug small wells in the gravel.

"I can't ever be happy again," wailed Susie, and, though Winnie's feelings were too deep for expression in the English language, she succeeded in voicing such a series of mournful noises that the little swallows in the nest under the house-eaves called to their mother and cuddled together in fright.

Papa had taken the two boys to Newburyport to see the balloon go up, and to stay at home quietly with mama and play with their dolls, even if they did have a chocolate cream apiece, seemed the flattest thing on earth to Susie and Winnie. For the balloon ascension had been long talked of, and was a great event to the children; but Newburyport was six miles away, and mama had concluded that it would be too long a drive, in the heat and dust, for the little children.

But she was sorry for her disappointed little girls, and she came out on the lawn to them. "The balloon goes up at four o'clock," she said, "and then we will go upstairs and take the spyglass, and I have no doubt we can see it nicely from the east window."

So, at just four o'clock, a group of eager faces gathered at the east window. A few of their nearest neighbors came in, because the house was on a hill with a clear view from the windows.

"Now," said mama, "look just at the left of

the upper church-steeple, and by and by you will see the balloon."

Five minutes past four, and no balloon! Would it fail them after all?

Ten minutes past four! Life was hard to bear for the little people. The minutes were hours to Susie and Winnie.

Twelve minutes past four—and look! The balloon shot into the air, up, up, till it seemed to the excited children that it had disappeared above the clouds. There was a strong east wind, so there was no danger of its going out to sea; and by and by, so slowly as to be almost imperceptible, it seemed to come nearer. The two children watched it for nearly an hour, and then, as it seemed to go away toward Haverhill, they lost interest in it.

Cousin Alice took them down the road to pick berries. "When George and Eddie come home," she said, "they will tell us just how it looks close by."

As the sense of their loss at not seeing it nearer had not left them, she tried to divert their attention, and succeeded so well that they had quite a merry time in the bushes, and forgot to watch the balloon. It was almost six when they started for home.

They were nearly there when some one called from directly over their heads.



WINNIE.

Oh, wonder of wonders! What was that? Had the moon that they had wanted so often when they were little tots come right down to them, man and all, and was he calling to them?

But cousin Alice shouted, "The balloon! the balloon! Run, children, run!" And then came mama and auntie and all the rest, and they all ran together. The great balloon was steadily descending toward them, and soon it was so near that they could almost catch hold of the rope that was hanging from it; and the man in the basket was waving his hat and calling to them.

Cousin Fred had a pail of milk in his hand, and he called out to the man, "Come on down, won't you?"

"I will," answered the man; "help me."

He was going to land right on their hill! Oh, what hurrying of little feet! Oh, what big eyes! Oh, what a day for the children!

The drag-rope had a big knot in the end, which caught between the limbs of an apple-tree. Cousin Fred climbed into the tree and untwisted it, and some other men who had gathered got hold and pulled the big balloon down to earth.

"Steady there, steady," called the man in the balloon; and slowly, slowly, down, down came the great wonder till the basket rested on the ground.

"Bring rocks from the wall," said the man, "and put them in the basket."

The basket, as most of our young folks know, hangs underneath the balloon; this one might have been four feet by three feet in size, and looked very small compared with the great inflated brown top. All around the rim of the basket were gay little flags of all nations.

So the men brought great rocks and piled them on the sand-bags remaining in the basket, and thus kept the balloon steady, for only enough gas had been let out barely to allow it to descend to the ground. Then Professor Blank (the man who came in it) put out the anchor. The anchor is different from a ship's anchor, as it has many sharp points around a center, so that if thrown out it will fasten into the ground somewhere. The other rope was tied to a tree opposite the rope attached to the anchor; and the balloon swayed quietly to and fro as if contented with its resting-place.

Mama asked Professor Blank if Susie and

Winnie might get into the basket for a minute, for the sake of saying that they had been in a balloon. He lifted them in on the top of the rocks that were piled there.

Just think of it! the little children who two hours before had cried on the lawn because they could not go to Newburyport and see the balloon go up were now sitting in the very thing itself. Never will they forget that day. They could look up through the ropes and flags, and see the great swaying balloon above that had been so far into the air.

The balloon was left on the hill for the night, and the people gathered from far and near to see it. Papa and George and Eddie came home planning to tell the little children all they could about the balloon, and you can imagine their surprise at seeing it looming up behind their own house.

Professor Blank stayed with them all night, and kindly and patiently answered the many questions asked him. He said that when he left Newburyport the balloon went directly up into the air for three miles. At that distance, he said, one would become somewhat deaf and be troubled with a ringing in one's ears.

"Were you not frightened?" some one asked.

He laughed, and answered that he was eating his luncheon then. "I had been hard at work getting ready to ascend," he added, "and after I was once up I took it easy. I have been up a hundred and sixty-nine times and have never yet met with an accident."

He said that no tongue could describe the grandeur of the sights from a balloon, or the sense of restfulness as one sails along. "Dizzy? Oh, no, indeed! There is little sensation of moving; the earth seems to be leaving you, instead of your leaving it."

He said that when over a river everything at the bottom was visible if there were no ripples.

"In a thunder-storm? Oh, yes; I have been in a thunder-cloud so black that I could not see my hand before my face."

"Was there no danger?"

"No danger from the lightning—lightning has never been known to strike a balloon; but the wind was terrific, and the balloon danced about like a mad creature."

The balloon he was using then held twenty

thousand cubic feet of gas. The one he used on the last Fourth of July, when he made the ascension from Lowell, Massachusetts, held eighty thousand cubic feet. The balloons of olden times were made of silk, but now they are made of cotton goods oiled.

"Are you never troubled to get gas enough?" was asked. "Yes," he answered, "both for quantity and quality. For these reasons I prefer making my own gas. We made the gas for the ascension at Newburyport. We used six thousand pounds of sulphuric acid, six thousand

Some of the rocks and sand-bags were taken out of the basket, and the professor took a few of the people, one by one, up with him in the balloon to a height of about a hundred feet. This he could do without using additional gas, as the wind took the balloon up as if it were a huge kite, and stout arms pulled it down by means of the drag-rope.

I am sure that none who ascended that day will ever forget the magnificent view of ocean and inland, or ever cease to be grateful to Professor Blank for his kindness and patience.



"THE GREAT BALLOON WAS STEADILY DESCENDING TOWARD THEM."

pounds of iron, and the same amount of water. The cost of filling this balloon is about one hundred dollars."

Professor Blank told Susie and Winnie about his two young daughters, and how many times they had ascended with him.

But at last mama said that *her* daughters must go to bed if they wanted to see the balloon in the morning.

At about nine o'clock on the next morning a crowd of people gathered on the hill to see Professor Blank start out in his balloon once more. And then, as the day was fine, he gave to a fortunate few a rare treat, and one that they will consider a great event in their lives.

Mama did not dare to let the children go up, for fear they would be frightened and fall; but they were allowed to climb into the basket, and even dear little baby, who was only ten weeks old, was put in, and was given a little swing with some one holding the rope.

At about half-past ten the remaining rocks and a few of the sand-bags were removed, the last words were spoken, and amid hearty cheers from the people Professor Blank sailed away in his big balloon whithersoever the wind listed.

After he had gone Susie took hold of Winnie's hand and held it very tightly. "Oh, Winnie," she said, "let us take our money that we are saving for a pony and buy a balloon!"

QUEER CARRIERS.

BY GERRISH ELDRIDGE.

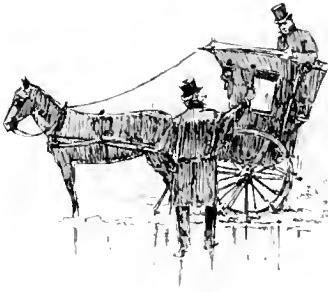

A QUEER CARRIER WHEN YOU COME TO THINK OF IT.

FROM the days of the winged Pegasus, the aspiring horse of Bellerophon, and from those of sharp-backed and raw-boned Rosinante, who bore the crazy Don Quixote, down to our own day, the horse has been the animal most used by man as carrier, charger, courser, hunter, and cart-horse.

True, the humble second cousins of the horse have filled the place of drudge and servant in the work of bearing burdens or hauling loads. The donkey, indeed, has been a useful animal ever since the remotest times known to history. General Washington, it is said, introduced them into this country; and all over

key is noted for docility and affection for its owner, and many a barefooted boy, driving his well-loaded pack-mule to the mill or to town, knows what a slow, steady, uncomplaining, helpful little creature it is.

But there are many countries and many circumstances where the possession of a horse or even of a donkey is beyond the means of those who serve as carriers. I am not considering, of course, those mighty carriers, the elephant, the dromedary, and the camel. These are exceptional animals, as are also the ox of our own land, the Egyptian buffalo, and the zebra of India, which are employed under unusual conditions, where great strength or endurance is required. In Germany and other parts of Europe, dogs are in very general use among the poorer classes as carriers; and, indeed, many New Yorkers can remember how,



A PATIENT BEAST OF BURDEN.

the civilized world the donkey and the mule are accepted as the best, the most patient, and the most tireless of all the beasts of burden. Although vicious when ill treated, yet the don-

more than forty years ago, the dog was very largely used by the ragmen and traveling peddlers of New York. Every morning the little wagons, some with two and some with four

wheels, would come down the street, drawn by one or two dogs, and guided sometimes by a woman and sometimes by boys.

This use of dogs came, without doubt, from

The dog of the Eskimo, as the explorers have all told us, is, of course, the swiftest and



A BELGIAN DOG-CART.

Holland and Belgium, where the dog has been in service as a beast of burden for many years. In almost every Dutch or Flemish city these "dog-carts"—not the stylish vehicle of that name which we meet in the park or on the avenue, but literally carts drawn by dogs—may be seen. It is usually a four-wheeled affair, and holds as much as a porter's hand-cart; not infrequently the dog's helper, on the other side of the pole, is a stout boy or girl.

In the Dutch dog-carts the dog is securely harnessed in—and so, indeed, is the boy when he is at the pole. The huckster-women who own or drive the dog-carts generally live in some of the little villages on the outskirts of the large Dutch or Belgian towns, and bring their farm produce for sale in the city streets.

On pleasant days, many of these little wagons may be seen on city corners, their wares offered for sale by the shrewd driver, while the dogs, with harness partly loosened, lie asleep at the roadside or beneath the body of the cart.

If trade is dull, the dog is awakened, the harness tightened, and off goes this queer conveyance through the streets to some more populous or promising quarter of the town.

most highly trained of these canine beasts of burden; and within the Arctic Circle from Greenland to Kamchatka many an Eskimo lad knows how fast and far these fierce yet well-trained Arctic "dog-horses" can carry them.



A MONKEY JOCKEY.

In fact, the point to which the training of dogs as "haulers" or draft-animals may be carried is measured only by the strength of this



ARCTIC CARRIERS — THE ESKIMO DOGS.

docile friend and helper of man. Any boy or girl who has watched the doings of a troupe of trained dogs must be aware of this; for one

the ring with all the zeal and fleetness of high-bred race-horses.

We all remember the story of "Sindbad the Sailor," and how the horrid "old man of the sea" made poor Sindbad carry him picka-back so long. We have always pitied Sindbad for this heavy task, but do not always remember how many men and women there are, in all parts of the world, who are little better than beasts of burden. The coolies of the far East are less expensive carriers than horses or even donkeys; and Mr. Stanley, in his wonderful African journeys, was always followed by a host of Zanzibari porters. You will find such porters, too, in India, in South America, in China, and in Egypt; and even in more highly civilized countries these human carriers are no infrequent sight.

Not many years ago, on the highroads about Wittenberg, in Germany, travelers frequently met an old woman trudging slowly along, pushing before her a light wheelbarrow loaded with bundles and parcels.

The old woman was at least sixty, but she was so cheerful and uncomplaining that the people had no hesitation in employing her. She had many knieknacks and parcels to carry to and from the city, into which, three or four times a week, she pushed her barrow, which folks called "the Wittenberg Express."

This plucky old woman walked with her express wheelbarrow at least ten miles each trip,



"THE WITTENBERG EXPRESS."

of the most interesting feats in the circus-ring is the race of trained dogs, ridden by monkey jockeys, in which the eager racers dash around



AFRICAN CARRIERS OF IVORY.

and her earnings, a small fee for each parcel, served to support herself and her two invalid daughters, who could do only a little sewing. The old woman would allow no one to pity her; she liked the work, she said, and was only sorry that as she grew older she could not make such frequent trips, for her earnings were helping herself and her children.

So, you see, there are all manners of queer carriers and burden-bearers in the world, from that fleetest of postmen, the carrier-pigeon, which takes a message through the air for hundreds of miles with the speed of an express train, down to the locomotive, the bicycle, the trolley-car, and the automobile, which once would have been considered "queer carriers" indeed, but that time is now long past.



ON THE CARAVAN ROAD IN AFRICA.



FAMILIAR QUEER CARRIERS: THE SPRING MANGELVERS OF THE SKEWARD SQUAD.



THE little Kangaroo
 (If this story is quite true)
 Could not be made to bathe him in the river.
 He said he never yet
 Saw water quite so wet —
 The mere suggestion made him shake and shiver!

His mother said, "Absurd!
 You 're a ninny, on my word!
 What well-bred jungle creature would act so?
 The little Elephants
 Are glad to have the chance —
 Their bath is just a frolic, as you know.

"The little Barbary Ape
 Does not try to escape
 When threatened with cold water and the soap;
 The Hippo-potamusses
 Don't make such awful fusses,
 Nor the Jaguar, nor the little Antelope.

"The mild, obedient Yak
 Would never answer back,
 Nor does the Rhino-cino-roarer-horse;
 And the baby Crocodile —
 Why, the water makes him smile;
 And he takes his daily plunges as of course."



THE LITTLE ELEPHANTS.

The little Kangaroo
 (A naughty thing to do!)
 Made up an ugly face and fell a-weeping!
 "The Puma and the Lynxes,
 And all the little Minkses,
 The Silky Tamarin,
 The Ounce and Pangolin,
 The humpbacked Impofo,
 The shaggy Buffalo,
 May bathe, and wash, and rub,
 And splash, and dash, and scrub,—
 But I just won't!" and off he went a-leaping.



FIRST AID TO THE INJURED.

BY DR. EMMA E. WALKER.

I. BURNS.

"OH, Jerry," said John, "I've thought of the jolliest way to spend our vacation! Let's go camping—really, truly camping, I mean, not a tent on our own lawn. I am sure father and mother 'll let us, if guardie goes along with us to see that nothing terrible happens."

"Guardie" was Mr. Wilson, the boys' tutor, and they had given him this name because their father called him their mental guardian. Dr. and Mrs. Sturges were going abroad this summer, so they had promised their boys a little extra treat in their vacation, and they had planned this camping party. Of course they talked it all over with guardie, and he said that he knew just the place where they could have "great fun." They could row and fish, and go on long trolley-rides, and explore the country, and do all sorts of jolly things. It was a place where he had lived himself when he was a boy, and he knew every inch of the ground. It was the beautiful Blennerhassett Island, which lies in the middle of the Ohio River, between the shores of West Virginia and Ohio. It is an ideal spot for a summer camp, as many young people know, for there is never a summer when the island is not visited by merry parties.

Mr. Wilson decided on the night train because the boys would be more amiable after a good night's sleep than they would be if they had to travel all day.

It was an excited little party which tried to stow its possessions away in the sleeper; for after they had piled up their fishing-tackle and golf-sticks, their overcoats and valises and lunch-boxes, there was hardly room left for the children themselves. The boys found, however, that the train did not take them directly to their destination; after reaching the nearest town, they had to take a stage down to the river, where they found a little launch awaiting them which took them directly to the island.

It did n't take them long to pitch their little tent and get their camp in order. Guardie had written ahead to some of the farmers, and they had an old kitchen stove ready for the boys to cook on. Jerry and John called guardie their "chef," and said they 'd be his assistants. They drew lots to see which one should get the first breakfast, and this work fell to John, who really was more pleased than otherwise to start in.

Mr. Wilson mixed the griddle-cake batter, for he was an old camper and knew just how to do it. John began to fry the cakes, and they certainly were a great success; but as he was buttering the griddle for the last batch, the grease took fire, and, suddenly flaring up, the flame caught his cotton blouse. Mr. Wilson grabbed a heavy steamer-rug, and, quickly wrapping it about John's body, threw him flat on the ground, smothering the flames. John was frightened, but not badly hurt. However, his arm had been slightly scorched, and guardie quickly sprinkled some baking-soda over it and bandaged it with a piece of soft linen.

John soon felt better, and Mr. Wilson said: "Boys, now this is a fine chance to talk a little about burns. You know, John, that 's one of the first things you 'll have to learn when you go to medical school. Suppose you begin by asking me questions."

"All right," said Jerry. "What makes the skin get red?"

"That 's a leading question, as a lawyer might say, and I could n't have asked a better one myself; for that 's the first thing you notice in a slight burn. I 'll tell you why the skin gets red; but first I 'll tell you something else, and that is this: there are three kinds of burn, as your father would tell you if he were here. The slightest kind is like that on John's arm, and I presume he thinks that was painful enough before we put on the soda and bandage."

"I guess you 'd have thought so if it had been your arm," piped John.

"The second degree of burn is one in which a blister comes. The third degree is a deep burn, and goes down into the flesh. When the skin is slightly burned, like John's, some of its tiny cells are injured. Too much blood rushes to the part, and that is why it looks red. But in a few days these little cells that have been hurt die and fall off,—or, as the doctors say, desquamate,—and new cells grow and take their places. Now, when you have a little burn like John's, do as I did this morning—sprinkle baking-soda or flour over it, and then carefully bind it up with clean, soft linen. This is to keep out the air. But you would n't do this if the skin was broken. I remember, at a Fourth-of-July party last year, a boy had his hand badly burned by a cannon fire-cracker. It was down on Long Island, and you know there is a great deal of lockjaw in some parts of the island."

"Lockjaw, guardie! Do you mean it goes there visiting, or lives there?" said John.

"Lockjaw lives in certain places, just as we live in our houses. It's a germ. These germs are very fond of the earth of old gardens; then, when a boy or a girl gets a cut on a finger, and digs in the garden and gets some of the dirt into the cut—you may look out for a case of lockjaw. But the people who were with this boy when the cracker went off covered his hand with a thick salve, and then wrapped it up with heavy bandages.

"When he came to the city that night his doctor was frightened; for, as he told me, all the germs that were on the hand were shut right in, and could n't get out even if they had a mind to. He took off the bandages at once, washed and picked off the salve, and covered the hand with wet dressings."

"Well, what are wet dressings?" asked Jerry; "and why did n't he put on baking-soda, as you did on John's?"

"I know why," said John; "because when the skin is broken you must n't ever put on any kind of powder. Father says so; it gets hard, and when they try to take it off it will hurt terribly."

"You're right, John; and it will not only

hurt, but it will sometimes tear off the flesh. Wet dressings are pieces of bandages soaked in water, or sometimes in oil. And in case of a burn which goes down deep the best thing to do before the doctor comes is to cover it with oil. Make some carron-oil by mixing linseed-oil with lime-water, half and half. Or you may soak a bandage in water that has baking-soda dissolved in it, as I might have done for John."

"Why could n't you use just olive-oil—the kind that mother puts on lettuce?"

"You could," said Mr. Wilson; "but never put on a bandage that will stick to the raw flesh and have to be peeled off afterward."

"Guardie," said John, "what about blisters? Is it right to prick them or let them alone?"

"That depends upon the blister," said guardie. "If it is loose and wabby, as Jerry says, let it alone. That loose skin is the very best kind of dressing for it. But if the blister is bulged out hard, like a rubber balloon, then prick it underneath at a little distance from the edge of the blister, running the needle just under the skin till it enters the blister, so that the water will run out and the skin covering be left unharmed."

"What would you prick it with?" asked John.

"Never with a pin. Take a bright, new needle, and dip it first into boiling water for a minute."

"Well, another thing, guardie: What made me feel so queer? I felt 'kind of gone' all over, as grandmother says."

"That was shock; you always feel upset by a burn. That is sometimes the worst part of the accident."

"Well, guardie, anything more about burns that we want to hear—I mean that John wants to hear?"

"Yes, there 's one thing more, boys. Did you think that burns by fire were the only kind of burns?"

"I burned myself with sealing-wax last winter," said Jerry.

"Yes, and the cook's baby drank some lye last week," said John; "and they said he was burned inside."

"Exactly! You see, there are other kinds.

And one other thing that causes bad burns is an acid. Next winter, when we begin to study chemistry, you'll learn about two things called acids and alkalis."

"What are alkalis?" said John.

"It's pretty hard to tell," said guardie; "but lye is an alkali, and so are soda and potash and ammonia—you can get a little idea that way. When you have an alkali burn, pour over it an acid, like weak vinegar or lemon-juice and water. And if you are burned by an acid, as carbolic acid or sulphuric acid, dip the burned spot into water to dilute the acid and then put on any alkali—saleratus or washing-soda. Alcohol greatly relieves the pain of a carbolic-acid burn. Even common mud is good for acid burns, because it has alkali in it. That's the way to treat a bee sting. You remember the one you had last summer?"

"I guess I do," said Jerry.

"When I burned my hand with the sealing-wax, you just put it under the faucet to cool it, and let the sealing-wax come off by itself," said John.

"Yes, and the same way with pitch," said Mr. Wilson. "For you will do great harm if you try to pull off the wax at once."

"There's a lot more to burns than I thought there was," said John. "Are we through, guardie?"

"Not quite. If you ever see an accident

in which any one's clothes are on fire, just do as I did this morning: grab up something woolen, because that does not burn easily,—a blanket or rug, or a coat, or a piece of carpet—never anything cotton,—and quickly wrap it about the flames, and throw the person on the floor if you have to. If your own clothes catch fire, never run or get in a draft; lie right down, with a rug or a blanket round you, and smother the flames. And, boys, one last thing: never, when there is a cry of 'Fire,' run out of a crowded building. It is very risky, and you are much better off to stay where you are until the stampede is over; then you can go out safely. But if you're caught in a burning building, and the smoke gets thick, cover your face with a wet handkerchief or towel, if one can be had; and if it's hard to breathe, crawl along the floor till you can get out. The best air in a burning room is always on the floor, because the smoke is lighter than the purer air and rises."

"That seems funny," said Jerry.

"Well, it's true, if it is funny," said Mr. Wilson. "But, above all, boys,—and this is the last thing,—never lose your head; self-control may save your own life, as well as some one else's, some day."

"Well," said John, "we know something about burns, anyway. Come on, Jerry; we've got to wash those dishes." And so began the first day of camp life on the island.

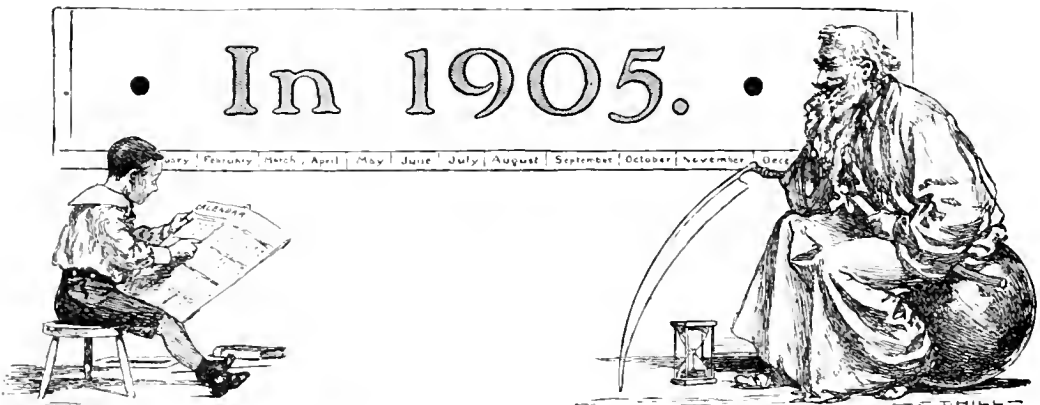

FATHER TIME: "THE LITTLE SCAMP! HE'S LOOKING THROUGH THE CALENDAR TO FIND THE HOLIDAYS!"

PAPER-DOLLS.

BY RUTH INGRAHAM.



HERE we come, little folks, spandy and new,
Ready to give you all something to do.
We're quite at your service to frolic and caper,
Whenever you get out the scissors and paper.

AN ARTFUL WISHER.

ONE wish only I give to you:
Make the best of it, little one.



What do you most wish to come true,
Of all the wishes under the sun?

One wish only I have from you?
I wish all my wishes to always come true!

PHILEMON AND ESTELLA.

PHILEMON JOHN and his sister Estella,
When walking out, carefully share their umbrella;
And that both may be equally safe from the weather,
Each holds out a hand as they walk on together,
To make sure, you see, that it really is blowing
Or shining or raining or hailing or snowing;
For otherwise they would scarce need their umbrella,

Philemon John and his sister Estella!



THE CLAM-DIGGER.



HERE is a clam-digger, basket and spade;
 Hat could n't be bigger, very fine shade.
 Oh, what a proud snigger! — he 's just been
 paid.

GRANDPA AMES.

Good Grandpa Ephraim Silas Ames
 Goes walking out each sunny day;
 He loves to see the children play,
 He calls them fondly by their names:

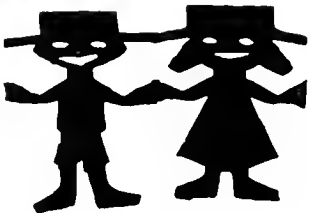

They all wear broad-brimmed hats
 pulled low,
 They all wear frank and open smiles,
 And are quite free from wicked
 wiles;
 No wonder grandpa loves them so!

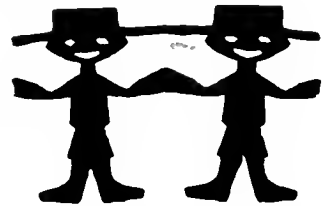

THE DANCING LESSON.

HERE is a happy little one
 Who 's having just the best of fun!
 Who would n't be
 In greatest glee
 To have a little fairy
 girl
 Come in and teach
 her how to whirl
 With steps so light
 and airy?



To skip and dance and turn and twirl,
 And spin about in merry whirl,
 To slide
 And glide
 From side to side —
 Oh, would n't any one of you
 Be glad to have a lesson, too,
 From a "really truly" fairy?

Lizette Gertrude Evangeline,
 Azalia Gazelle Clementine,
 And little Zelda Antoinette;
 Stephen Percival Alphonso,
 Fitzjames Summerville Alonzo,
 And young Jerome Eliphalet.

THE PRACTICAL BOY.

BY JOSEPH H. ADAMS.

SEVENTH PAPER.

BOATS.

IN this article we give a few of the simpler forms of sail and mechanical boats. The warning should be made at the outset that the boy use the greatest care in constructing a boat, not only for the natural pride he will take in making

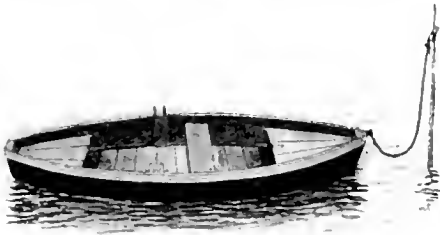

FIG. 1. A DOUBLE-ENDED SHARPIE.

a good job, but for the still more important reason that the safety of all on board is dependent upon his skill and conscientious work in making the parts strong and thus avoiding the possibility of open seams and other leaks.

A DOUBLE-ENDED SHARPIE.

CEDAR, white-wood, pine, or cypress are the best woods to use. Obtain two boards, 15 or 16 inches wide, 14 feet long, and $\frac{3}{8}$ of an inch thick, planed on both sides. From a piece of hard wood cut a stem 18 inches long and 4 inches wide, with beveled planes, shown in perspective and section at A and F in Fig. 2. The long side boards are to be cut at bow and stern as shown at C. The bow recedes 3 inches and the stern is cut under about 4 inches.

With galvanized screws attach the bow ends of the boards to the stem-post, so that the top of the sides will be flush with the flat top of the post, and as a result you will have a V-shaped affair resembling a snow-plow, which

must be bent and formed in the shape of a boat. From a board $\frac{3}{8}$ of an inch thick cut a spreader, D, 10 inches wide, 48 inches long at one side, and 42 inches at the other. Arrange this between the boards about midway from bow to stern, so that the bottom of the spreader is flush with the bottom of the sides, and draw in the rear ends of the boards and tie them temporarily with a piece of rope. The stern-plank is cut the same shape as the stem-post, B, but it is 3 or 4 inches wide. An inner keel is then cut 6 inches wide and pointed at the bow ends and stern, where it is attached to the lower edges of the sides and flush with those edges.

The spreader and stern-plank will give the sides a flare, which will have a tendency also to curve the bottom of the boat slightly from bow to stern. The bottom planks are 4 inches

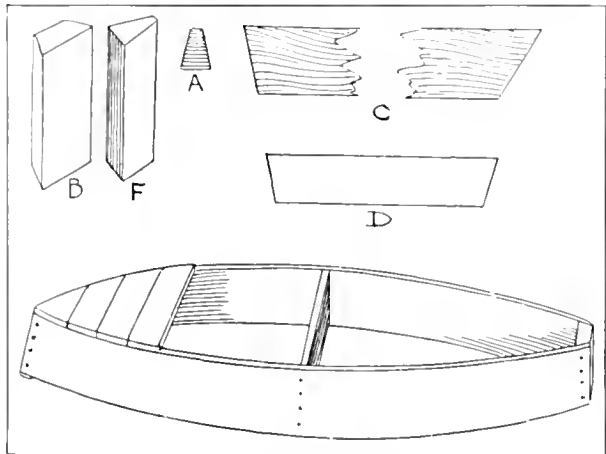

FIG. 2. DETAILS OF A DOUBLE-ENDED SHARPIE.

wide, of clear wood, and must not have tongue-and-groove edges, but should be plain, so the white lead and lamp-wicking will make a tight joint when the planks are driven up snug to each other. A short keel, or shag, is fastened

to the under side of the sharpy, and extends from bow to stern, with the ends rounded up.

At the outside of the sides, an inch below the top, a gunwale-strip is made fast.

A SPRIT-SAIL SHARPY.

It is not a difficult matter to convert a rowing-sharpy into a sail-boat. The row-boat features need not be altered nor the seats removed, as the rib and brace work for the deck can easily be fitted and fastened over the seats, which will lend added strength to the deck.

Just behind the front seat and at the forward edge of the back seat, cross-ribs are made fast to the sides of the sharpy. Between these, and 8 inches from the sides of the boat, additional lengthwise braces are sprung and securely attached at the ends and provided with short cross-braces. The deck planking is nailed to these ribs, and the seats under them give a substantial support to both the ribs and deck. The opening or cockpit will be 6 feet long and of varying width, as the side decks are 8 inches

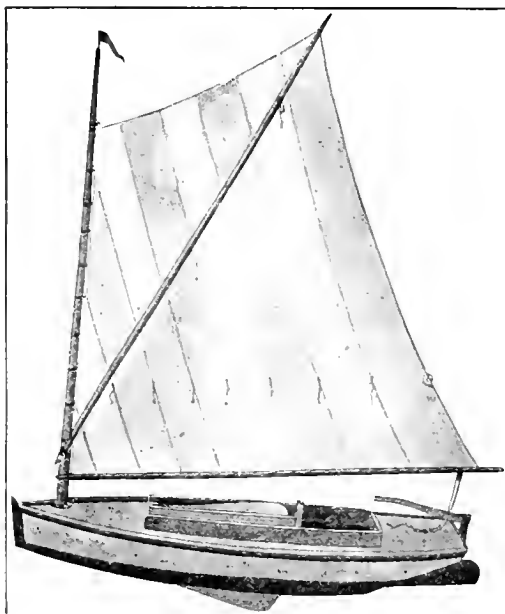

FIG. 4. A SPRIT-SAIL SHARPY.

wide and follow the line of the boat's sides, but amidships it should measure about 28 inches.

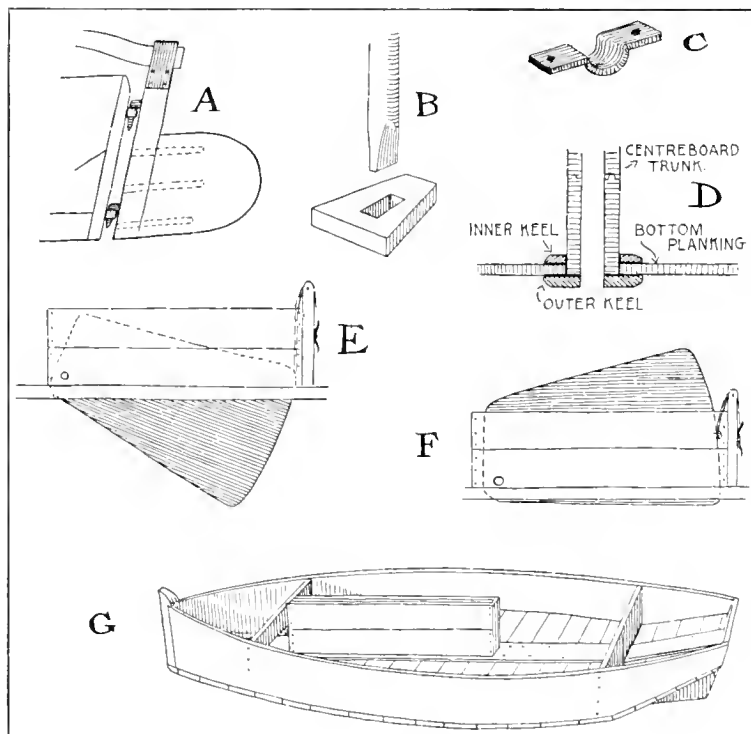

FIG. 3. DETAILS OF A SAILING-SHARPY.

The decking is done with narrow strips of pine, cypress, or cedar, $1\frac{1}{2}$ inches wide and $\frac{3}{4}$ of an inch in thickness. The canvas should be tacked down over the outer edge of the boat and the inner edge of the cockpit. A gunwale strip an inch square is to be nailed along the top edge on both sides of the boat, and an inch below the top nail fender-rails along each side. Arrange a combing in place that will project 4 inches above the deck, and attach the boards fast to the inner side of the ribs with screws, as shown in the illustration of the finished boat. Ten inches back from the stem-post, bore a $2\frac{1}{2}$ -inch hole for

the mast. The mast-step, to be fastened on the bottom of the boat, is shown at B in Fig. 3.

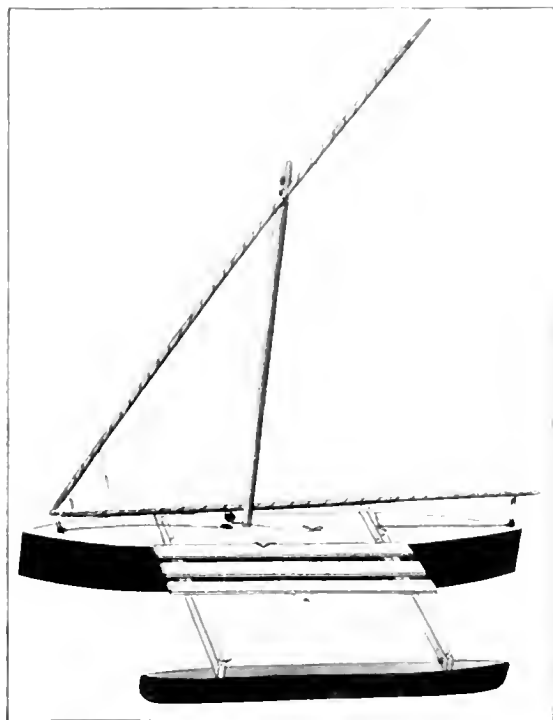

FIG. 5. A PROA. (SEE PAGE 642.)

The mast measures 14 feet high by 2½ inches at the base, and the boom 13 feet long by 2 inches in diameter, both tapering near the end. They are made of spruce or pine.

It is impossible to hold a boat on the wind without a centerboard; but as this sharpy has none, a leeboard will be required to keep her from drifting leeward. This board can be made 5 feet long and 30 inches wide, and hung over the lee side when running on the wind, where ropes and cleats will hold it in place.

It can be made of three planks banded together at the rear end with a batten, and at the forward end it is strapped across with bands of iron.

With a sail of twilled or heavy unbleached

muslin, this boat can be driven through the water at five or six miles an hour.

If the boat is not an "adapted" rowing-sharpy, but was planned as a sailing-boat, a centerboard should be built when the keel is laid. As shown in Fig. 3 the well is 3 feet from the bow, and is 5 feet long, 18 inches high, and 13¼ wide inside to allow for the centerboard, which is 1¼ inches thick, 4 feet and 9 inches long, 30 inches wide at the back, and 24 inches at the front. It is made of tongue-and-groove boards, which are attached to posts 13¼ inches square at bow and stern with stout screws. The well is mounted on the keel and set in white lead, then securely fastened with screws. A slot is cut in the keel the same size as the inside opening of the trunk—that is, 2 inches wide and about 5 feet long.

The bottom planking is butted against the sides of the trunk at the middle of the boat, as shown at D in Fig. 3, where it is nailed to the keel at the middle and to the lower edge of the sides at the outer ends. An inner keel 6 inches wide is laid over the bottom planking through the center of the boat from stem to stern.

The centerboard is attached to the trunk with a hard-wood pin near the forward lower end, and when it is drawn up it will appear as shown at F; when lowered it will look as at E. There is an advantage to this fin-like form of

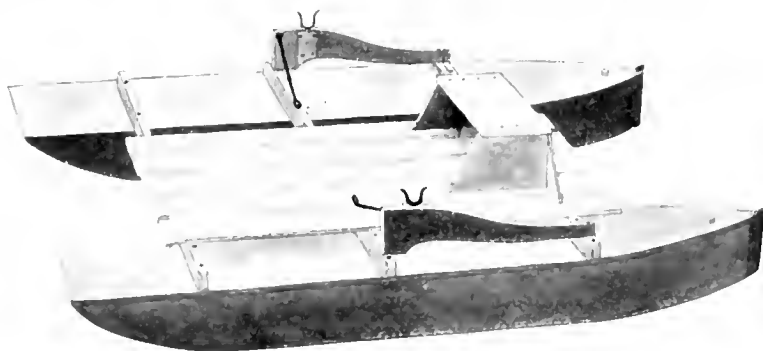

A ROWING CAYAMAKAN. (SEE PAGE 643.)

the centerboard projecting below the bottom of the boat, for if the boat should suddenly come into shallow water or upon a bar or rock, the slanting front edge of the board will gently and gradually raise it out of danger. An eye and

rope, made fast at the middle of the rear edge, will provide a means for raising and lowering the centerboard. Several wooden pegs along the front edge of the well-box, convenient to the steersman, will be useful in fastening the loop of the centerboard rope, thus enabling the skipper to quickly fasten and hold the board at varying heights. Another plan is to have a cleat on the well; on this the rope may be fastened after hauling up the board at the desired height.

A PROA.

This is a perfectly safe boat, and lies close to the water. (See Fig. 5 on page 641.)

Get two 10-inch planks, 16 feet long, and spring them 5 feet from either end, so that they come together at both ends, and are separated 15 inches along the middle for 5 or 6 feet. Diagram H in Fig. 8 will serve to show the construction of this, except that the proa is pointed at both ends. Between the sides place three or four spreaders, two of which should be stout enough to receive the bolts that will hold the two cross-braces. Set a step-block for the mast, then plank the deck and bottom, using plenty of white lead and lamp-wicking between the joints. The cross-braces are of 2 by 4 inch spruce and 6 feet long, and their outer ends are bolted to a solid spruce timber 12 feet long, 4 inches wide, and 10 inches deep; sharpened at each end with an adz, a draw-knife, or chisels and plane, as shown in Fig. 5.

A mast 12 feet long and 3 inches in diameter is stepped 7 feet from the bow, and to it a latteen rig is lashed fast, having the gaff 18 feet and the boom 15 feet long. A block and tackle at the bow will regulate the angle, and another at the stern the position of the sail. Cross-wires for braces may extend under the short decking to steady the outrigger and to keep it from racking the braces. The illustration shows but three boards on the outrigger; it would be safer to have it completely decked.

A ROWING-CATAMARAN.

FOR safety on the water—as near as safety can be assured—there is nothing to compare with a catamaran (see Fig. 6); for it is absolutely “non-capsizable,” and if not damaged to the leaking-point, one or the other of the two boats will float and hold up several persons.

The boats are 14 feet long, 18 inches wide, and 14 deep, including the bottom and deck. Use pine, white-wood, cedar, or cypress $\frac{3}{4}$ of an inch thick and planed on both sides. At the bow, the ends of the sides are attached to a stem-piece of hard wood, as shown at H in Fig. 8; and having poured boiling water on the forward ends, they may be drawn around a spreader 16 inches long and 12 inches wide, provided with two V-cuts at the bottom. These are placed at the bottom so that any water may be run to one end of the boat and pumped out.

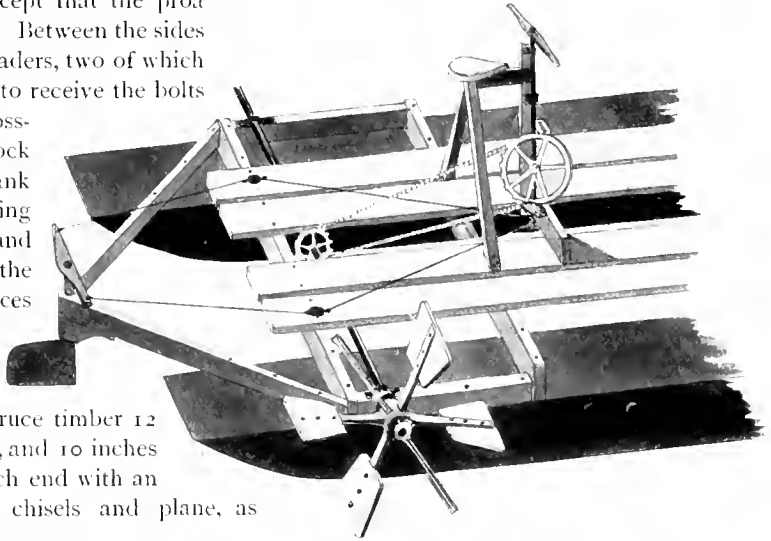

FIG. 7. A SIDE-WHEEL CATAMARAN.

The first spreader is placed 3 feet from the bow, and three or four more of them can be fastened between the sides. The bottom is made of pine or white wood boards, well leaded in the joints and along the edges where the bottom and top boards join the sides; and before the top or deck is placed on, the interior of the boats should have two or three good coats of paint. Three cross-stringers of spruce $2\frac{1}{2}$ by 4 inches, and 6 feet long, are securely attached

to the boats, and on these the deck of 4-inch boards is made fast. Between the middle and forward stringers, at the ends, two boards are at-

sprocket-wheel on an axle. At the outer side of each boat, between the middle and rear cross-braces, fasten two pieces of wood 2 inches wide and 3 inches high, and 6 or 8 inches from the rear end make two V-cuts for a 5/8-inch axle to fit into. At a blacksmith's obtain two old carriage or buggy wheels and cut the spokes so that they will be 14 inches long from the hub. Dress one side of each spoke flat so that a paddle can be attached to it with screws. The paddles are of hard wood 8 inches wide at

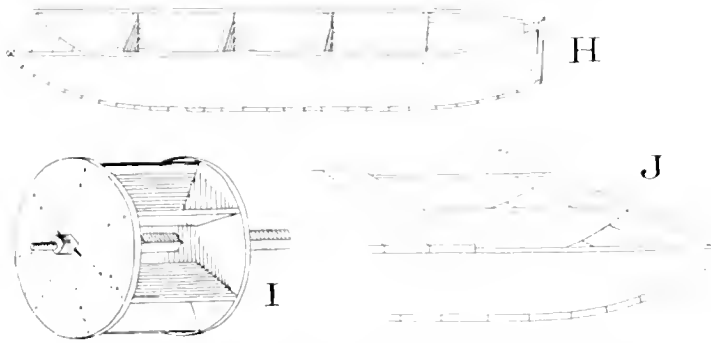

FIG. 8. DETAILS OF A SIDE-WHEEL CATAMARAN AND A BICYCLE-BOAT FOR TWO.

tached on which the row-locks may be fastened. These boards are 8 or 9 inches wide, and cut away at the front so that they are not more than 2 or 3 inches wide. The high ends are braced with round iron braces as shown, and where the row-locks are mounted a short plate of wood is screwed fast to the inside of each piece, as can be seen in Fig. 6. Near the front cross-piece a seat is built and braced with a board as shown in the illustration; and, with another boy at the stern, sitting on the deck, this catamaran will be well balanced and will prove very seaworthy as well as a light boat to row.

the outer end, 6 at the inner end, and 6 inches deep. Fasten the paddles on with brass screws.

Have a blacksmith heat the ends of an axle and pound them square, then slip one hub over the iron and with hard-wood wedges make it fast. When the axle is in place the other wheel can be slipped on and attached in a similar manner.

An old bicycle-chain and sprocket, together with the axle, cranks, and pedals, can be arranged on a frame, so that a saddle can be mounted the proper distance above the pedals. These bicycle parts can be bought cheap.

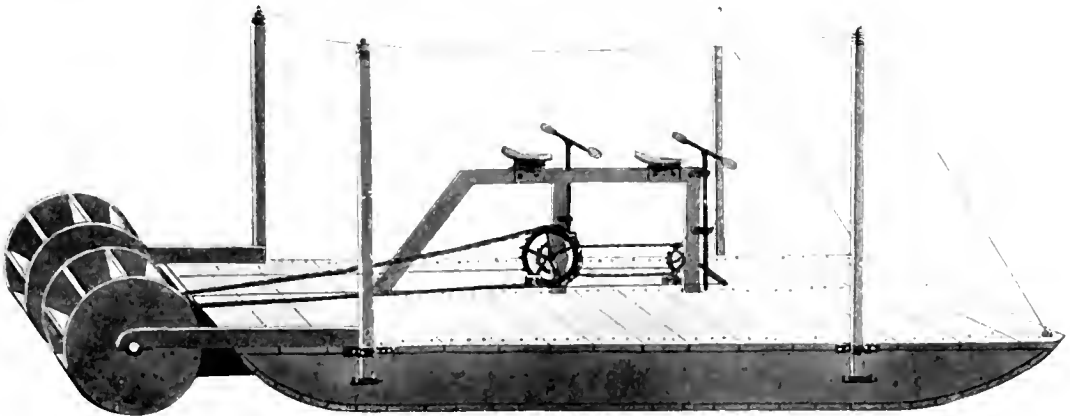

FIG. 9. A BICYCLE-BOAT FOR TWO.

A SIDE-WHEEL CATAMARAN.

A BICYCLE-BOAT FOR TWO.

THE rowing-catamaran can easily be converted into a side-wheel boat (Fig. 7.) by removing the middle deck-slat and making an opening through which a chain will lead to a cog or

A NOVEL feature for the propulsion of a flat-bottom boat, or punt, is shown in Fig. 9. The deck may be boarded over or left open as in the side-wheel catamaran.

KALISTA WISEFELLOW.

BY MARY DILLON.

III. CAMEL'S HUMP.

THERE was another thing for which the back yard was used besides for chickens and ducks, and there was something else nice in it besides the hollyhock hill.

In the winter when the ground was all covered with snow, the children used that long hill from the kitchen windows to the street for coasting, and the other nice thing was a "hump" right in the middle of the hill. When their sled struck the hump they would give a great leap and go flying through the air and come down on the ground ever so much farther down the hill. It was great fun, but you had to hold on tight, or very likely you would go flying off the sled, and the sled would go running off by itself clear down to the fence. And if you were a very little boy like Hector, you might pick yourself up and find you were crying because your face and hands were all scratched by the hard snow.

Of course Kalista never went down the hill alone, but sometimes Achilles or Theodora took her on their sleds in front of them and held her fast, and thought there was never anything so funny as her little shriek of fear and delight when they went over the hump.

One winter evening the FAMILY were all at the supper-table. It was only half-past five o'clock, but the lamps were lighted, and the warm red curtains were drawn to shut out the cold and the dark.

The LEARNED PROFESSOR looked across the table to mama and said:

"It 's a glorious moonlight night, My Love; it reminds me of our sleighing party to Mount Holly. Do you remember it?"

Mama smiled and blushed; but before she could reply, Achilles said:

"Oh, papa, won't you let us go coasting to-night down Camel's Hump?"

And then Theodora eagerly chimed in:

"Oh, yes, *please*. And let 's go over for the Coltons, and we 'll fix up the omnibus, and it will be *such* fun!"

The children were all excitement at once. Hector's eyes sparkled while he waited breathlessly for the answer, and Kalista laid down her porridge-spoon and said, "P'ease do," in her very sweetest tones.

The LEARNED PROFESSOR looked at mama and mama looked at the LEARNED PROFESSOR. It was mama's rule that the children should not go out after supper, but she knew that the best way to have rules kept was to let them be broken once in a while when there was a very good reason for it.

"What do you say, Dear?" said mama, a little doubtfully.

"It 's a glorious night," said papa, persuasively.

"I think I will have to take a look at it," said mama, and she rose from the table and went to one of the windows and drew aside the curtains.

There she saw a beautiful sight. The whole garden, away down to Fairy Home, was covered with a shining white floor like marble. Every bush and every tree stood out as clear as day in the moonlight, and the bare branches and twigs threw a network of shadows on the shining marble that looked like the loveliest lace. The LEARNED PROFESSOR went to the window and stood beside mama, and they both looked out on the beautiful sight and never spoke a word for as much as a minute; then he said:

"I think we will have to let them go, Dear."

There was not much more supper eaten that night. Achilles went flying over to Mrs. Colton's to invite Mary and Charlie and Lizzie and Johnny to a moonlight coasting party.

Mrs. Colton said they might go. "But you don't want Johnny, do you?" she asked.

"Oh, yes 'm," said Achilles. "Mama 's



"ON THE VERY TOP OF CAMPUS HUMP SAU THE LEARNED PROFESSOR"

the top of the hill ready for a start, and mama and papa were at an upstairs window watching them.

The "omnibus" was a long ladder fastened to two stout bobs that Achilles and Charlie Colton had made themselves. Achilles sat in front with the guide-ropes in his hands and was engineer, and Charlie sat at the very back and was conductor. Next to Achilles sat Mary Colton, holding fast to Johnny, and she had quite a safe and comfortable seat because she was right over the front sled. Theodora, with Kalista tight in her arms, sat on the back sled just in front of Charlie, and between Mary and Theodora sat Lizzie and Hector, and they had to hold on very tight indeed, for there were no sleds under them; they had to sit on one round of the ladder with their feet on another and hold fast to the sides.

going to let Kay go." And that was quite true; Kalista was going coasting by moonlight, just like a big girl. Mama had not thought of her when she said the children might go; but Kalista slipped from her chair, and took hold of mama's dress, and looked up in her face, and said, "Me, too!" with such a pleading air, and the children all begged so hard to let her go, and Theodora said she would take care of her and hold her tight, that at last mama said she might go.

And then, such a time as there was getting all bundled up and getting the "omnibus" ready! But by six o'clock the four little Coltons and the four little Wisefellows were all at

Then when all were in their places, the conductor shouted "All aboard!" three times, and the third time Charlie and Achilles pushed with their feet, and the long sled started slowly down the hill. Very slowly indeed, at first, but soon it was going faster and faster, and by the time it got to the hump it was going very fast. And my! what a leap it gave when it came to the hump! If Achilles had not been a *very* skillful engineer and Charlie a *very* careful conductor, all the passengers would have gone overboard. But Achilles held the ropes very tight and true, and Charlie, who was kneeling at the back, used the toe of his copper-toed boot for a rudder, and so, although the omnibus squirmed and twisted through the

air, it came down all right, with its passengers all safe and sound, and screaming with delight at the lovely jolting. Then they shot over the smooth snow straight for the fence; and when the engineer shouted, "Slow up!" Achilles and Charlie both dug their heels into the snow, and they came to a stop just three feet from the fence. Then all the passengers got off and trudged up the hill, and Charlie and Achilles pulled up the omnibus ready for another start. That was part of the fun, only Kalista and Johnny went so slowly, and the rest of the passengers were so impatient, that the next time Charlie and Achilles and Mary and Theodora made two queen's chairs and carried them up.

Papa and mama watched the children from the window a long time, and papa said it made him wish he was a boy again. After a while, when mama went down to the kitchen to see about something nice she was having cooked there, papa put on his high silk hat and went down into the back yard to be a little nearer the fun. When the children got up to the top of the hill and saw the LEARNED PROFESSOR standing there, they all began to beg him to go down the hill with them. "It was such fun! If he only knew how nice it was, he would surely try it!"

Now I think very likely that was just what the LEARNED PROFESSOR had come out for, to get an invitation to ride down the hill, so he did not need much urging.

As I said before, he had on a high silk hat, and he also wore a kind of coat they called "swallow-tail," with two long narrow tails in the back. Charlie very generously gave up his seat to the LEARNED PROFESSOR, because it was a post of honor, and took one for himself farther front. The LEARNED PROFESSOR did not kneel as Charlie had done, but sat down on the sled; and at first it was a little hard to find out what to do with his long legs. But at last they were all fixed, and the conductor shouted, "All aboard!" for the third time, and they started.

"Oh, is n't it lovely, papa?" said Theodora, as they began to go faster. The LEARNED PROFESSOR'S high hat was planted firmly on his head, his hands were tightly grasping

the sides of the ladder, and his coat-tails floated straight out on the breeze behind him.

"Yes, it is very nice," he said a little doubtfully. At that moment they reached the hump. Up into the air went the first sled, and then as it began to plunge downward, up went the second one twice as high as the first. The LEARNED PROFESSOR gave a little gasp when the first sled struck the hump, but the children did n't hear it, they were all screaming with delight. As the second sled struck and then came down on the ground with a thump, Theodora said again: "Is n't it *lovely*, papa?"

There was no answer, and Theodora looked around.

On the very top of Camel's Hump sat the LEARNED PROFESSOR, his legs straight out in front of him, his coat-tails straight out behind, resting on the snow, and half-way up the hill his high hat calmly reposing right side up.

He did look *too* funny. He looked "so 'sprised," Hector said, and the children laughed so hard, they nearly tumbled off the sled. As for the LEARNED PROFESSOR, after one hasty and sheepish glance at the house, to make sure that mama had not seen him, he laughed louder than any of the children. And then when they came back up the hill the LEARNED PROFESSOR insisted he must try it again. He had n't been prepared for such a sudden jolt at first, but next time he would know how to stick on. So down they all went again, and this time the LEARNED PROFESSOR went over the hump all right, and the boys gave him three cheers, and the LEARNED PROFESSOR joined in the cheers, which Achilles said was not at all proper. Then when they got to the foot of the hill the LEARNED PROFESSOR picked up the little Kalista and tossed her up on his shoulder, where she held on with her arm squeezed tight around his neck, while he trotted up hill with her.

And then they all begged him to go down "just once more." And that time he carried Johnny up the hill pickaback, and when they got to the top of the hill, there was Janie waiting for them. Janie said it was half-past

seven, and Mrs. Wisefellow said they were all to come into the dining-room, and Mary and Charlie and Lizzie and Johnny must be sure and come too.

Such a short hour and a half! They could hardly believe it possible that it was half-past seven! They would have been very sorry to leave such fine sport, only the invitation to the dining-room sounded very nice, and although it had been only two hours since supper, they had played so hard in the clear, sharp winter air that they were quite ready for something to eat.

What a happy troop of children gathered around the table in the bright, warm dining-room! Everybody was talking at once and all were trying to tell mama about the LEARNED PROFESSOR going over Camel's Hump. Mama thought she had never seen such rosy cheeks or such sparkling eyes, or heard such merry laughter.

And then Janie brought in the great silver soup-tureen of oyster broth, steaming and giving out the most delightful odors.

The children were not all fond of oysters, but they all liked the hot broth into which they broke the crisp crackers. The Big Boys and Mary and Theodora were quite proud of liking the oysters as well as the broth; though with Theodora eating oysters was quite a recent accomplishment, and she found three as many

as she could manage—much to her mortification, for Mary Colton proudly ate *six*!

But the hot broth and the warm room were too much for the little Kalista after her vigorous exercise in the keen air. She struggled with all her might, but the white lids with the long dark lashes *would* keep dropping down over the bright eyes, and the curly brown head *would* keep nodding in a very disgraceful manner. Achilles had just been telling over again, for the third time, how funny papa looked sitting on top of the hump, with the sled flying down the hill without him, and the children had shouted with laughter just as much the third time as they had the first, and little Kalista had tried her best to join in the laugh, and had only succeeded in making one sleepy little gurgle, when her head sank beside her bowl of broth.

And, just as on the evening of the Christening Party, she was sound asleep at the table; and, just as on that evening, the LEARNED PROFESSOR took her up softly in his arms and carried her to Janie. But this time she did n't wake up at all; only, when Janie had put on her pretty white nightgown and tucked her in her soft, warm crib, another sleepy little gurgle of laughter rippled out of her rosy mouth, and Janie thought she must be dreaming of how papa went over Camel's Hump.

THE END.





NATURE FOR YOUNG
AND SCIENCE FOLKS.
EDITED BY
EDWARD F. BIGELOW.

Black-and-white warbler.

American redbird.

Chestnut-sided warbler.

Magnolia warbler.

"If on any day in May the tree-tops are full of flitting little warblers, it is no sign that the following day will find them still there."

THE RETURN OF THE BIRDS.

THE yearly return of the birds is one of the greatest of nature's puzzles. For many years grown-up folks have been observing and re-



A ROBIN PULLING AN EARTHWORM OUT OF THE GROUND.

cording facts pertaining to this puzzle. In this all young folks can aid.

Nearly all small birds make their long flights by night, spending the daytime quietly feeding and resting, so that if on any day in May the tree-tops are full of flitting little warblers, it is no sign that the following day will find them still there. Some kinds, like phoebes, song-sparrows, meadow-larks, and bluebirds, come very early—as soon as the snow is all gone and the south-sloping hillsides begin to feel warm and "smell of spring."

But it is not until May, when the buds are bursting and the apple-trees are in blossom, that the vast numbers of little birds come to stay with us or to pass on farther north.

What is the best place to look for birds? Why, every kind of place has its charms for different kinds of birds. Along the little streams or lakes you can find dainty sand-pipers, green herons, and phoebes. A king-fisher's rattling cry may catch your ear; you may even see him plunge headlong into the water and come out with a gleaming shiner in his big bill. In the marshes are the beautiful clear-piping redwings and the chuckling marsh-wrens, and you may startle a big brown bittern. Along the roadways the vesper-sparrows may fly ahead of you, showing their white tail-feathers as they go.

The great things to learn about birds, after you have come to know a number of kinds, are: first, that every kind does things in its own way; second, that they group themselves



THE RED-SHOULDERED BLACKBIRD MAKES MUSIC IN THE MARSHES.

naturally into families as much by similar habits as by what scientific men call "character." Thus, flycatchers dart out and catch insects on the wing, with a snap of the bill, returning to their perch to wait for another victim. Sparrows like to be near or on the ground. Woodpeckers like to climb about in the trees, bracing on their stiff tails, head up. It has been ascertained that, in the main, birds like to follow valleys when they can, even going back for short distances to enter a valley that will lead them in their true direction. Many birds do not migrate at all, like the crows, chickadees, and many hawks and woodpeckers; while others, like the red-poll linnets, snowflakes, crossbills, and butcher-birds, come to us only with very cold winters.

But how birds know when to go, and which



A KINGFISHER PLUNGING HEADLONG INTO THE WATER.

way to turn, are things not yet well understood, because the flights are at night and the great movements start a long time before it is really necessary for the birds to go. They leave their winter homes (perhaps in Mexico) when there is no perceptible change in the weather, and return from their breeding-grounds in most cases while their food-supply is at its very height—long before it is cold or the grass and weed seeds and insects begin to get scarce. In many cases, too, the young birds of the year, who have never left their homes before, lead the long procession in the great southward flight and are followed later by their parents.

To show how well birds know where to go, even when they cannot see their goal, I will



A HUMMING-BIRD EXTRACTING SUGAR FROM THE BLOSSOM.

tell of a vast colony of sea-birds I once visited far up in the Bering Sea, on a volcanic island called Bogoslof. There is always a dense fog in this sea, and the island is always shrouded in steam. Yet, as our ship approached, more and more birds were seen flying over us, until, when we got quite near, a constant stream of them came out of the gloom and were lost again,—all going in the same direction, which, as our compass showed us, was straight for the island. And when some of our party took a ship's boat and went ashore, the birds were seen to dive right into the thick columns of steam, where their single egg was laid on some tiny shelf of rock. Yet, while it was impossible to see a bird fifty feet in the dense fog, birds had been going over our ship for fifty miles. LOUIS AGASSIZ FUERTES.

While sight is of the first importance to the older and more experienced birds who know the way, young birds, who are making the journey for the first time, doubtless rely on their hearing to guide them. Birds' ears are exceedingly acute. They readily detect sounds which to us would be inaudible. OLAFSON.



"CAW, CAW, CAW! WHY DID YOU ALL GO SOUTH? WE STAYED AT HOME!"

SMALL BUT INTERESTING FORMS OF LIFE.

ONE day I found, in a damp place in the road, what looked like a dab of green paint. I was sure it could not be that, so I took some of it home for examination under the microscope. There I discovered that my "find" was composed of hundreds of minute polliwog-like things, each with a very slender lash-like thread at the front. They each had a soft, green body, and a red spot that seemed to be an eye. The tiny creatures, scores in a drop of water, swam about, with the whip-like lash foremost and wiggling so fast that it was almost invisible.

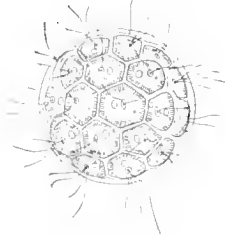

"MANY BODIES, EACH WITH TWO ANTERIOR LASHES."
(*Pandorina morio.*)

I had found a lot of euglenas, as they are called. You will find them described in the botanics as plants and in the zoölogies as animals, so you may take your choice

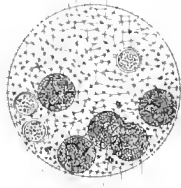

"STUCK ALL OVER WITH GREEN BODIES THAT LOOK LIKE DOTS."
(*Volvox globator.*)

and put them in either class. This is not very important, because among these lowly beings the difference between plants and animals is pretty much wanting.



"LIKE A MIS-SHAPEN FLASK WITH A LONG NECK AND A MOUTH AT THE END WHERE THE CORK SHOULD GO."
(*Chetospira Mulleri.*)

One reason why we think that euglena is a plant is that many undoubted plants, at certain seasons of the year, break up into just such little tadpole-like bodies, which swim away and finally grow into new plants. Another reason is that there are two or three small water-plants — at least they are, on the whole, more like plants than animals — which are hardly different from a lot of euglenas growing together in a colony. One of these, pandorina, is made up of several bodies similar to euglena, even to the red eye-spot, but each with two anterior

lashes. The bodies are bunched together in a spherical mass, with their numerous trembling threads sticking out in all directions. Sometimes the colony breaks up and the separate parts swim away to freedom. Sometimes each one of these parts splits up into sixteen



"SUGGESTS A SWAN."
(*Trachelocerca olor.*)

smaller ones, which swim away and become full-sized colonies in their turn. Another of these water-plants is the volvox, a hollow sphere about the size of the periods on this page, and stuck all over the surface with green bodies that look like dots. These are so numerous that when the whip-like lashes beat the water all together, they send the little green ball rolling and spinning along in a lively way.



"LIKE AN ANCHOR WITH HORNY FLUKES."
(*Ceratium tripos.*)

On the other hand, there are plenty of creatures which are usually counted as animals, but which, with the exception of their color, are nearly like euglena in structure. Some of these are red, some brown, some yellow. Seen under the microscope, they sparkle like little jewels, and where they occur, a thousand to a thimbleful of water, they color large patches of the ocean.

Besides these there are many microscopic creatures which are beyond all possible doubt animals and not plants, living almost anywhere in water, on the surface of the mud, or even in the bodies of larger animals. One sort is in form like a misshapen flask with a long neck and a mouth at the end where the cork should go. Another suggests a swan; a third an elephant. A fourth is like an anchor with horny flukes, while still another lives in a dwelling shaped like a goblet. In short, there is no end to their strange forms and wonderful structure.



"LIVES IN A DWELLING SHAPED LIKE A GOBLET."
(*Cothurnia putula.*)

Some of the commonest kinds, however, are not less interesting. One has only to dip up a few gills of water from any pool or ditch, and let it stand in the window for a few days, to get hundreds of infusoria of several different kinds. The trumpet-animalcule (stentor) and the slipper-animalcule (paramecium) are particularly easy to find, and large enough to be seen, though with some difficulty, with the unaided eye. These move by means of countless little cilia, as they are called, instead of one or two long lashes, and they go whirling over and over as they swim, so that their course is straight ahead in spite of their lopsided bodies.

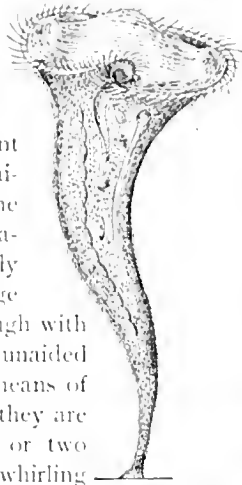

THE TRUMPET-ANIMALCULE.
(*Stentor polymorphus*.)

They are so transparent that one can see much that goes on within them, and make out the balls of half-digested food and the smaller animals or plants which they have more recently swallowed. It is a lively sight when half a hundred slippers get together around a mass of bacteria, of which they are fond. They shove and push and butt one another for all the world like so many little pigs around the trough at dinner-time.



THE SLIPPER-ANIMALCULE.
(*Paramecium aurelia*.)

Another common infusorian, smaller than these and therefore harder to find, is the bell-animalcule (vorticella). When full-grown and in comfortable quarters, this is always fixed to some support by means of a long stalk. It has a tiny, roundish body, with a crown of cilia about the upper edge. When disturbed it vanishes like a flash; but if one looks closely, he finds it clinging to its support, its stalk coiled up like a spiral spring, ready to uncoil and let the creature blossom out again when the danger is past.



THE BELL-ANIMALCULE.
(*Vorticella nutans*.)

E. T. BREWSTER.

A FREAK OF NATURE.

In my country rambles I, of course, always carry a sketch-book, and very often one of my cameras. In the book I make "studies" for pleasure or for future use; with the camera I get a more perfect picture of what I have n't time to sketch, or of what will not admit of sketching. My wife and I were out mountain-climbing one fine afternoon last summer, when, in a wood of chestnut-trees, she called my attention to two that had grown together.



THE CHESTNUT-TREES THAT HAD GROWN TOGETHER.

They were tall and on a steep hillside or mountain, and the light on them was bad, but I decided that I must get a picture of them. I thought the sun would possibly get into the woods in the morning and light them up.

I took my "pocket-camera" and tripod, and trudged up the steepest mountain that I ever climbed, just to get that picture. The light on the trees was perfect, and I hastened to get the exposure before it changed too much.

It was difficult to adjust the tripod on such a steep, uneven place; but a friendly moss-grown log helped me, and I set my shutter at stop 64, and gave it one second.

My wife tells me of two young trees, one of which was rubbed by the wind against the other till the bark was rubbed off and a natural graft made, which in later years appeared like this pair, which is so interesting.

HARRY B. BRADFORD.

THE PAPER-NAUTILUS.

THIS beautiful, silvery-white shell, with radiating and encircling rows of low prominences, has been called the argonaut or the paper-sailor. The former name recalls that of the ship which carried the bold Greek adventurers

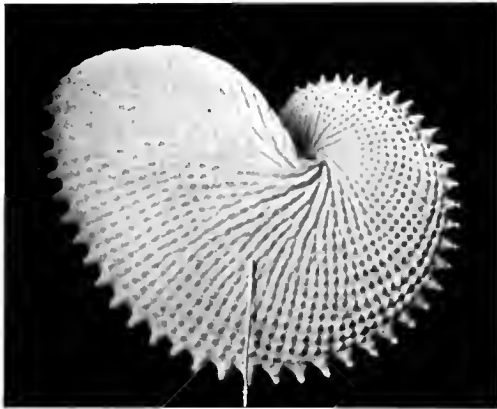

SHELL OF THE PAPER-NAUTILUS.

who, centuries ago, started out to find the Golden Fleece. It is an exquisitely light and delicate structure. The lovely creatures inhabit the warmer seas, and are sometimes found along the coasts of Florida and of California. They appear in great numbers at Messina, Italy, during the spawning season. The specimen figured here is at the American Museum of Natural History, New York City, and is regarded as one of the most perfect known. All the delicate and fragile ornamentation of its surface is preserved, and its outline is unmarred by any break or disfigurement. Perhaps the shell ranks among the gems in the animal world because of its mathematical perfection and symmetry.

L. P. GRATACAP.

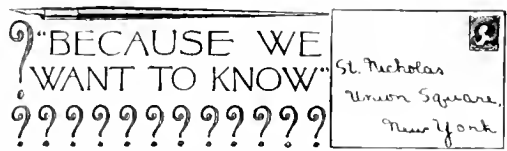

CUTTING GLASS UNDER WATER.

STRATHCLAIR, MANITOBA, CANADA.

DEAR ST. NICHOLAS: We all take such an interest in Nature and Science, that there is a question which I should like to ask that department, "because we want to know."

How is it that glass can be cut under water with a pair of scissors, when they make no impression on it when used out of the water?

Wishing St. NICHOLAS long life and success, I remain,
Yours truly,

GERTRUDE MAY WINSTONE.

Glass may be "cut," or rather broken off, with a heavy pair of scissors, or shears, more conveniently under water than out of it, because the water prevents the small pieces from scattering and endangering fingers or eyes. The scissors have as much effect on the glass out of the water as in.

FOOD HABITS OF SHINERS.

WABASHA, MINN.

DEAR ST. NICHOLAS: I live on the Mississippi River, and have noticed that the shiners, or skipjacks, as they are called here, are always caught on the surface of the water, although they are never seen there like gars. Why is it that they are not caught under water like other fish? Ever your reader,

JAMES G. LAWRENCE.

Fishermen say that there are two classes of fishes, those which feed at the surface and those that seek their food nearer the bottom. Your shiner is not only a surface feeder, but it is very fond of fresh air, and may often be seen to come to the top for a good breath. In many

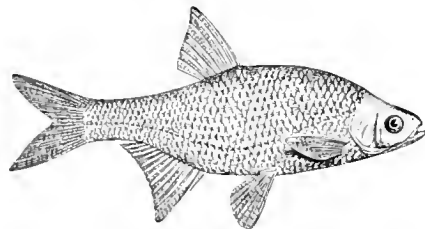

THE SHINER.

other parts of the country they feed well under the surface, and I have seen them eating at the bottom of small creeks and ponds.

A HOLE IN A SHELL.

PHILADELPHIA, PA.

DEAR ST. NICHOLAS: I inclose in this mail a shell which I found last summer at Atlantic City. It has a



SHELL OF *FULGUR CARIA*
(Showing hole made by a drill-mollusk.)

true hole at one side. Can you tell me how the hole happens to be there?

Yours truly,
ABRAM KARSH (age 12).

Your shell is a small *Fulgur caria*, and the evenly cut hole on the side has been made by a drill-mollusk, *Urosalpinx cinera*. The shell you send is common on our coast, and grows larger than the size of the little specimen you send. This drill-mollusk is a great enemy of oysters. See further particulars in Mrs. Arnold's "The Sea-beach at Ebb Tide," published by The Century Co.

A WHITE ENGLISH SPARROW.

GERMANTOWN, PHILADELPHIA, PA.

DEAR ST. NICHOLAS: We have been very much interested in a little white bird that has been in our neighborhood this fall, with a flock of sparrows. It is a pure white bird except for a few grayish-blue feathers and dark spots under its wings, and a dark blue spot on top of its head. We wonder if there could be such a thing as a white sparrow.

One of your readers, SARA CASHY (age 10).

Undoubtedly a partial albino English sparrow. They are frequently seen about the city. Most domesticated or semi-domesticated animals show a strong tendency to albinism.

W. S.

HOW THE TREE-TOAD CHANGES ITS COLOR.

ONTARIO, CANADA.

DEAR ST. NICHOLAS: I am very much interested in the tree-toads around here, and I should like to know more about them. The first tree-toad I ever saw was up the river about two miles, at a place which we call "Air Camp," because that is where we camp. The tree-toad was on a dead tree and was just the color of

the bark. This summer there was one on the kitchen window in a box of plants. It was bright green, the color of the leaves on the plants. Is the natural color of tree-toads green with black stripes? Will you please tell me more about them, and what makes them change color?

Your interested reader,

WINONA STEWART.

NORTHUMBERLAND, ENGLAND.

DEAR ST. NICHOLAS: Last spring I introduced into my greenhouse half a dozen small green frogs. I believe their original home was the south of France. They are really pretty little fellows, about two inches long, very clean and green, with a little round sucker on the end of each toe. By the aid of these they climb and cling all over the plants, and even on to the smooth surface of the glass and wood; and very funny it is to see one of them hanging by one toe for a second or two in the course of his rambles. They are certainly very easy to keep, as they find their own board and lodging, and at the same time are very useful in keeping down the flies which attack the plants; but they are very modest about it, for never since I have had them have I seen them eat or drink anything! They used to be very fond of climbing up the rose-vine at the side of the greenhouse, and I fancy some of them escaped through the open window in the warm weather, for now I usually only see two. Once one escaped and made his way into the house, where he was discovered in the back kitchen, and once or twice they have been found in the garden. One of the queerest things about them is their habit of barking: you can't call it croaking—it is a loud, sharp, chattering bark, like a small dog. We were all very much surprised the first time we heard it. I happened to see one of the vocalists directly after, and his throat was swelled as if he had been trying to swallow a marble and it had stuck half-way. One day one of them came into the drawing-room on a plant (I did not notice him as I was carrying it in) and startled some visitors by suddenly joining in the conversation!

Another queer thing about them is that they seem to



THE TREE-TOAD THAT CHANGES COLOR.
(*Hyla versicolor*.)

have no objection to heat and light: I would often find them on the hot summer days basking in the sun, and apparently enjoying it. When the cold weather came

on they both retired under a flower-pot saucer which I kept full of water on the greenhouse shelf, as a bath for them, where they remained huddled together, puffing quietly, as usual, but apparently in a state of hiber-



ONE OF THE HYLAS OR "SPRING PEEPERS" SWELLING HIS THROAT.

Imagine a man swelling his throat thus until it took a balloon shape fully three feet in diameter, and then letting the thing collapse with a deafening scream that could be heard fully eighteen miles! Yet this, supposing the *Hyla's* size and voice could be proportionately increased, is exactly what would happen.—MATHEWS. (This is *Hyla pickeringii*.)

nation. After Christmas, however, we had some much milder weather, and on looking under the saucer I found they had disappeared. Yesterday, however, I found one cuddled down between the leaf and stalk of one of the plants. I was tearing off the leaf, as it was turning brown, and he looked rather disgusted at being disturbed.

I would be very much obliged if you will tell me how it is that these frogs, chameleons, etc., change their color so as to match what they are resting on. When first I got them one was dark brown, and I suppose had been sitting on some earth; later I found one in a chrysanthemum-pot, and it was spotty gray-green like the leaves of that plant. It can hardly be a conscious action on the part of the animal, in the way in which a bird will conceal itself or its nest so as to harmonize with its surroundings; it is not quite the same as those animals that are colored so as to render them inconspicuous in the places they frequent, such as the lion or the Arctic hare. Buckland says that all the theories on the subject are unsatisfactory; but has anything been discovered since he wrote? And to how many colors can the animals change?

Yours truly,

M. MEARS (age 15).

The common American form of tree-toad, or, better, tree-frog (*Hyla versicolor*), ranges from very pale gray to almost black, often with a faint greenish tinge, and sometimes quite green. The common form in the north of Europe is a green of various shades, appearing occasionally as a bronze-brown. Tree-frogs change their color

when excited by light, heat, cold, variations in moisture, food, and the excitement of the chase. The impressions which reach them through their eyes appear to be the most important. The change in color depends on the movement of the blackish granules contained in cells located in the skin. These granules are at times collected into tiny masses, deep below the outer surface of the skin, and at other times spread out like little splatters of ink nearer the surface. The cells containing these granules (or coloring-matter) are called chromatophores, or color-bearers.

When black granules are condensed and withdrawn from the surface of the skin, the animal has the fixed color of the skin and in general appears light; when the granules are spread out and close to the surface, the color is variously modified, and becomes dark. These changes are chiefly under the control of the nervous system.

The very interesting power to change color is found in many other animals: insects and other invertebrates; many species of frogs and



A FAVORITE RESORT OF THE HYLAS.

Close by, in a corner lot between the two cross-roads of the village, lies a wretched little puddle, the home of countless *Hylas* until the June sun dries it up.—SHARP.

toads; fishes and reptiles, the classical example among the reptiles being the African chameleon.

THE EARS OF FROGS.

PHILADELPHIA, PA.

DEAR ST. NICHOLAS: I have been taking you for only about six months, and I like you very much in-

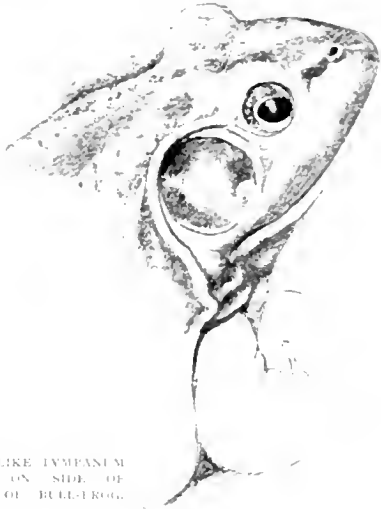

DRUM LIKE TYMPANIC
EARDRUM ON SIDE OF
HEAD OF BULL-FROG.

deed. I am a new subscriber, and I am delighted when I receive your lovely magazine. There is a question I would like to ask you, and it is: Have toads and frogs ears? I am almost sure they have, though we cannot see them. The question was brought up in school, and while some of the girls said they had, others said they did not; so I thought I would write to you, where I should get the right answer.

Wishing you great success and a long life, I remain,
Your faithful reader,

BEAURIC C. NATHANS (age 11).

THE EARS OF TURTLES.

CORNWALL (ROCK ACRE), N. Y.

DEAR ST. NICHOLAS: I have a glass case with five turtles in it—two snapping-turtles and three box-turtles. I have looked well for their ears, but cannot find any. Please tell me how they can hear.

Your friend and reader,

LEHLL HARVEY OCTERBERGEL (age 11).

AFFECTED BY A JAR, BUT NOT BY LOUD NOISE.

COLORADO SPRINGS, COLO.

DEAR ST. NICHOLAS: I have three turtles, and the loudest noises don't seem to disturb them in the least, although a slight jar excites them surprisingly.

Your loving reader,

EDWARD HINI.

The ears of a frog are the thin, flat spots back of the eyes. Scientists call the vibrating tissue over each spot a tympanic membrane. This vibrates after the manner of the head of a drum—only, of course, on a very small scale.

There is no opening as in the ears of higher animals.

Turtles have similar membranes a little back of the jaws, but they are smaller than in the frog, and do not show conspicuously. Indeed, unless you know just where to look, you will fail to find them, because they are below thick skin. You can usually feel this membrane, by pressing with thumb and finger on both sides of the head, as an elastic spot surrounded by a hard, circular wall.

In most fishes the internal ear does not have this tympanic membrane, and the "ear" is probably not for hearing, but an organ of equilibrium (that is, of keeping right side up) only. Some salamanders do not have this membrane, but others, and all the higher amphibians, like frogs and turtles, have the membrane.

Snakes have no membrane, and the hearing is right through the bone of the skull, which we can somewhat understand by comparing it to our hearing noises or other sounds through the partition between two rooms of a house. Snakes are not charmed by music.

Strange that such a myth so contrary to the actual facts should have originated. An animal of very imperfect hearing charmed by music! Regarding this, the following quotation from "The Vivarium" will be of interest.

I think the general belief that snakes can be charmed by music should be added to the list of fallacies about them. Snakes have no exposed ears, and, seemingly, their powers of hearing, like their powers of sight, are very limited. When a piccolo was played softly and shrilly before a case con-

THE HEAD OF
A PAINTED
TURTLE.

The beautifully variegated head and shell—red, yellow, blue, black—of the painted turtle makes it a very prominent object among the many attractions of a clear, sandy-bottomed pond. Sometimes it is found in the mud-diest, most dismal marshes, but it evidently prefers clear waters, for it is oftenest found there. There its colors show to good advantage.

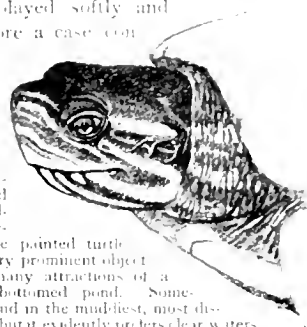

taining snakes, neither the music nor the noise made any impression upon them as far as I could see.—REV. GREGORY C. BAILEMAN, in "The Vivarium."

THE ST. NICHOLAS LEAGUE

FOR MAY.



"A HEADING FOR MAY" BY D. M. SHAW, AGE 14. (GOLD BADGE)

SPRING RHYME.

THROUGH sloping fields be-
decked with spring,
Where daisies bud and robins
sing,
With happy hearts and spirits
gay
We March through April
into May.

WHAT WE ARE DOING AND CAN DO.

THIS has been one of the League's very large months: more good poems, stories, drawings, etc., than we could find room to print or even to put on the Roll of Honor. Much of the work is almost professional in its touch, and many Leaguers who have reached the age limit, and are so sorry to leave us behind, need not fear for their ultimate success in the larger fields of art and letters which lie ahead.

Of course success will not come without a struggle—it never does, and it never ought to. The effort to win the prizes in the League is only a preparation for the greater struggle to win the greater prizes of recognition and material reward which the world has to bestow on those who labor long and well in the divers ways of literature and art. If the effort be conscientious and persistent, and if it is backed with only a little talent, some measure of success is sure. But never to confess discouragement, never to acknowledge defeat, to strive and keep on striving so long as life lasts and brain endures,—that is the way of winning, and it is for that way and for that life of unceasing effort that the League is a preparatory school.

It is five years ago that we were writing our first introduction to a May League. Most of those who were members then have passed beyond the age limit; some of them have become workers—successful ones—in the larger fields. But the advice we gave them that month, curiously enough, fits in with what we have just said, now, five years later, and may be repeated here. This is what we said:

"If there comes no encouragement whatever after several trials, it may be because you have undertaken something unsuited to you. If you have written five stories, for instance, and not obtained even honorable mention, suppose you try a poem, or a drawing, or a puzzle, or puzzle-answers.

There are many ways to obtain recognition through perseverance and conscientious effort. We cannot all have genius, but we can all have industry and perseverance, and in the long run the difference between these and genius is said to be hardly noticeable. Remember this, and that the value of faithful effort is worth more to us than the winning of a gold or silver badge."

PRIZE-WINNERS, COMPETITION No. 65.

IN making the awards, contributors' ages are considered.

Verse. Gold badges, **Mary Yeula Wescott** (age 15), Poplar Branch, N. C., and **Elmira Keene** (age 16), 31 E. Springfield St., Boston, Mass.

Silver badges, **Edward S. Ingham** (age 8), Irvington, N. Y., and **Dorothy Kerr Floyd** (age 12), 181 Cypress Ave., Flushing, N. Y.

Prose. Gold badges, **Henry B. Dillard** (age 14), Huntsville, Ala., and **Helen Davenport Perry** (age 13), 79 North Main St., Rockland, Maine.



"AN OLD RELIC." BY LAWRENCE V. SHERIDAN, AGE 17. (GOLD BADGE.)

Silver badges, **Bernard Nussbaumer** (age 11), 50 E. 108th St., New York City, and **Lawrence Burton** (age 10), Sullivan, Ind.

Drawing. Gold badges, **Ray Sapp** (age 17), 91 Starr Ave., Columbus, Ohio, and **D. M. Shaw** (age 14), 2 Tor Villa, Watts Road, Tavistock, Devon, England.

Silver badges, **Harold Sheffield van Buren, Jr.** (age 7), 15 Promenade des Anglais, Nice, France; **Charlotte Waugh** (age 15), 144 W. Robie St., St. Paul, Minn.; and **Richard A. Reddy** (age 17), New Brighton, Staten Island.

Photography. Gold badges, **Lawrence V. Sheridan** (age 17), 449 S. Clay St., Frankfort, Ind., and **Edmonia M. Adams** (age 12), House K, Navy-yard, Brooklyn, N. Y.

Silver badges, **Carl Stearns** (age 11), 14 Lincoln St., S. Framingham, Mass., and **Elsie Williamson** (age 12), 1270 Dorchester St., Montreal, Canada.

Wild Animal and Bird Photography. First prize, "Opssum," by **Lucien Carr**, 3d (age 17), Winchester, Va. Second prize, "Deer," by **Katharine E. Pratt** (age 13), 241 Clinton Ave., Brooklyn, N. Y. Third prize, "Duck," by **H. Maynard Rees** (age 13), 972 Euclid Ave., Cleveland, O.

Puzzle-making. Gold badges, **Fannie Tutwiler** (age 16), 113 31st St., E., Savannah, Ga., and **Edna Krouseage** (age 14), 527 Howard St., San Francisco, Cal.

Silver badges, **Mason Garfield** (age 12), 49 Library Place, Princeton, N. J., and **Catharine E. Jackson** (age 14), Seminole Inn, Winter Park, Fla.

Puzzle-answers. Gold badges, **Neil A. Cameron** (age 12), Sylvania, Pa., and **Marguerite Hyde** (age 12), 68 Dagmar St., Winnipeg, Man., Canada.

Silver badges, **Marjorie Mullins** (age 14), Franklin, Pa.; **Gladys Cherryman** (age 14), 188 Scribner St., Grand Rapids, Mich.; and **William Munford Baker** (age 14), 80 W. 40th St., New York City.

MY HOME BESIDE THE OCEAN.

BY MARY VERA WESCOTT (AGE 15).

(Gold Badge.)

In my home beside the ocean
I can hear the sea-birds cry;
I can watch them darting upward
Clear against the azure sky.
I can watch the white-winged vessels
Sailing onward out to sea;
In my home beside the ocean
I am happy as can be.

In my home beside the ocean
I can hear the billows roar;
I can watch the white-capped breakers
As they dash against the shore.

When old Neptune grows quite angry,
I can see the waves afar
Madly rush before each other
On across the sandy bar.

In my home beside the ocean,
When the spring has come again,
And I hear the low, sweet patter
Of the gentle summer rain,
Or the sun is shining brightly,
Then my life is filled with glee,
And the days pass—oh, so quickly!
In my home beside the sea.

A KIND DEED.

BY HENRY B. DILLARD (AGE 14).

(Gold Badge.)

About the year 1842 the greatest misfortune overtook a negro slave girl, by name Frances.

The old "marster" had died, the property being divided among several persons.



"AN OLD REEF." CARONADE FROM THE "QUANTICO" NOW AT THE BROOKLYN NAVY-YARD. BY EDMONIA M. ADAMS, AGE 12. (GOLD BADGE.)

A few of the slaves were to be sold; among them was Frances, who was about sixteen years old.

They were bought by a slave-trader who, to save trouble and delays by good-bys, determined to secure them on his vessel by a ruse.

The next day Frances received orders to board the vessel in the harbor and sell vegetables. This she did.

Soon other slaves arrived, and before long the vessel sailed away to Norfolk.

Frances was wild with grief. She did not know that the captain was her owner. Even if she had it would have made little difference; she was leaving home and everything she had ever loved and cared for. From Norfolk they proceeded overland to Alabama, camping at night or tramping over mountains and fording rivers during the day. When, after a long, weary journey, she reached Huntsville, Alabama, she was put on the block and sold again.

The years rolled away. Frances was freed with the rest of the slaves at the close of the war. She was now at work for my grandmother as cook.

All she could remember was that she came from the tide-water regions of Virginia. Her grief had so crazed her that she remembered nothing that had happened from the time she left till she reached Huntsville. At last, one day, she remembered the name Gloucester court-house.

My mother wrote that same day to the negro church at Gloucester, asking if anything was known of the family.

In two weeks Frances received a letter from her sister saying that she was alive and well, and that her mother had been dead only three years.

Frances left in a few days for her old home, and there met her sister for the first time in many years. The writing of that letter restored her to her only remaining relative, for if my mother had not written, it is very probable Frances would never have seen or even heard of her sister again in this world.

HOME LONGINGS.

BY EIMIRA KEENE (AGE 16).

(Illustrated Poem. Gold Badge.)

THOUGH from my window here I see
The ocean in its wild unrest,
The rocky beach, the craggy ledge
Where Nature gives her mightiest;

And though the sunset by that sea
Its own unrivaled beauty brings,
And leaving as it dies away
A half disgust for lesser things:

Yet still I miss the noisy cars,
The children's voices, shrill
and sweet,
Rising above the rest to make
The music of the city street.

The line of houses stretch-
ing far,
And fading in the city
blue;
The thousand things that made
home dear,
And greatest of the missing—
you.

For us the pleasure of our days
In our association lies;
Perhaps the earth-born stranger weeps
Within the gates of paradise.

The St. Nicholas League, now more than five years old, is an organization of St. Nicholas readers; the membership is free. A League badge and instruction leaflet will be sent on application.



"AN OLD RELIC." BY ELSIE WILLIAMSON, AGE 12.
(SILVER BADGE.)



"THE MUSIC OF THE CITY
STREET." (SEE IOEM,
"HOME LONGINGS.")



"AN OLD RELIC." BY CARL
STEARNS, AGE 11. (SILVER BADGE.)

A KIND DEED.

BY HELEN DAVENPORT
PERRY (AGE 13).

(Gold Badge.)

SHE is my heroine of kind deeds, and her name, Clara Barton, is known and revered throughout many different countries. Fame and honor she won for herself as a Red Cross nurse, and in the Civil War she nursed the wounded soldiers through sixteen terrible battles, among which were Bull Run, Antietam, and Fredericksburg. It was a long time before America consented to sign the Red Cross Treaty, but as a result of Clara Barton's long and untiring efforts the nation did so finally. At the head of this organization in America was my heroine of kind deeds. After the Civil War ended, she spent four years searching for soldiers who were reported as missing, and marking the graves of those who would never again hear the roar of the cannon. This was a hard and long task, and upon finishing it she was completely worn out.

Her physician advised her to go to Europe, and she finally decided to go to Switzerland, where the Red Cross Treaty was first signed. She had not been there long before the Franco-Prussian War broke out, and the Red Cross sought her aid, for they knew that her long experience would be of great value to them. She could not refuse, and once more went on the battle-field. Many soldiers will remember her for her kindness and devotion to them as they lay wounded on the field, but in my memory she will always remain the heroine of kind deeds.

She is old now, too old to follow the Red Cross any more; yet she has faithfully done her part.

One of my favorite authors says in a recent book, "She now sits in the evening of her life, and has many jewels in remembrance of her kind deeds."

It is a noble and kind deed to aid those who are willing to die for their country's sake, and if any woman's name ever be written in the temple of fame it should be Clara Barton's.

Lost or damaged League badges will be replaced free on application. This does not apply to prize badges, which cannot be replaced

KINDNESS.

(A story about Longfellow, never before published.)

BY LAWRENCE BURTON (AGE 10).

(*Silver Badge.*)

MY mamma has an old cousin living now in Columbus, Ohio, who has been a frequent visitor in our family.

A good many years ago he was a law student in Cambridge, Massachusetts, and while he was there the government of Brazil sent about twenty young men to our country to go to our different schools to study law. One of them, a Mr. Del Bal, who went to Cambridge, boarded at the same place with this cousin Phil, and they became fast friends.

Mr. Del Bal knew our language well, and a great deal about our literature; and he especially admired Mr. Longfellow's works.

He carried a letter of introduction to him, and was very eager for the time when he might call on him, but would not think of going to see him until he had learned all that was perfectly proper to do in our country in making such a call.

He wanted to know the proper time in the day to call, how long he ought to stay, and just what he should wear. He was so particular that every article should be exactly what we would consider correct, and that he might not make any breach of etiquette.

At last he went to call, and Mr. Longfellow himself met him at the door, in his cordial manner, and took him back through the long hall to his study.

Mr. Del Bal was so charmed with Mr. Longfellow, and his kind, friendly manner put him so at ease, that before he realized it he had stayed much longer than he had intended to. They conversed in Spanish, Mr. Del Bal's language, and he said afterward that Mr. Longfellow spoke the language as correctly as if he were a Spaniard.

When Mr. Del Bal rose to leave, Mr. Longfellow bade him adieu at the study door, and let him come down the hall alone. But when he reached the front door he could not get it open. He worked at it such a long time, it seemed to him, but he could not move it. Finally Mr. Longfellow must have heard him, for he opened the study door and came down the hall smiling. He said: "Well, Mr. Del Bal, I hope you will always find it harder to get out of my house than to get into it."



"GLOSSAL." BY EUGEN CARR, 3RD, AGE 17. (FIRST PRIZE, "WILD-ANIMAL PHOTOGRAPH.")

EVERY summer my sister and I
Play around, and pretend to fly;
In the play-house, around and around,
Chasing over a lot of ground.

Every summer my sister and I
Put on wings and climb on high;
Climb so high that we can see
Far, far over land and sea.

Every summer we do these things,
Climb the trees and put on wings;
So, some summer, if you'll come to see,
We'll show you how we climb the tree.

A KIND DEED.

BY BERNARD NUSSEBAUMER

(AGE 11).

(*Silver Badge.*)

MANY men have shown their bravery by doing great deeds, and have received their reward; but the story I am about to tell is of a different kind. It is of a man who cared little for praise, but who did more than his duty only for the good it would do to others.

It happened during Napoleon's retreat from Moscow in the winter of 1812, among the remains of the Brigadiers of Baden. These, for the most part ill or wounded, had retreated to Vilna in the hope of finding peace and comfort. The victorious enemy marched to this same place to refresh themselves. Using their power, they seized the best houses and rooms, and confined the poor German allies of Napoleon to the worst quarters. In this way a certain troop of about eighty officers was crowded into two rooms. Many were half frozen, and many lay in fever from their wounds. They were in a piteous condition, with no means of aid and no physicians, so that many of them died. Those who were left were captured by the Russians, and the outlook was very dark.

Unexpectedly one brave man



"DEER." BY KATHARINE F. PRATT, AGE 13. (SECOND PRIZE, "WILD-ANIMAL PHOTOGRAPH.")



"DUCK." BY H. MASAARD REES, AGE 13. (THIRD PRIZE, "WILD-ANIMAL PHOTOGRAPH.")

appeared upon the scene. He was military surgeon, and although he himself had escaped capture, he returned to Vilna to use all his powers to help his comrades. The act was particularly beautiful, for he might have returned home safely; but instead he ran the risk of becoming a captive and of sharing the famine, the cold, and danger of his fellow-soldiers. Not only did he help them with his medical skill, but he also gave them what money he had to procure expensive medicines and bread.

The greatest risk of all was in himself venturing out to get the medicines, because the Russians would torture and maltreat any of the Germans who ventured out. Many of those who had previously attempted it met with a sad fate. So this brave surgeon disguised himself as a Russian peasant, with high boots, a long coat, and a switch, and went out every night to bring aid to the suffering.

This story, which we read in old family letters,

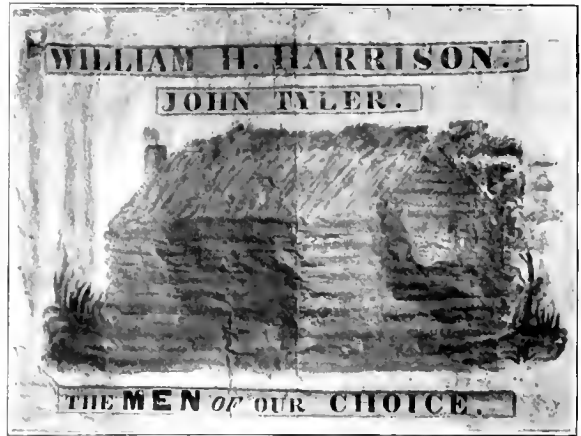

"AN OLD RELIC." LOG-CABIN CAMPAIGN BANNER, 1840.
BY GERTRUDE M. HOWLAND, AGE 12.

A KIND DEED DOUBLED.

BY ALLEN FRANK BREWER (AGE 15).

THE night of the blizzard in February, 1905, my uncle discovered, on arriving home, that a strange black dog had followed him. He did not take it in, however, as he thought it would go away. After dinner we heard a scratching noise on the front porch, and, looking out, we saw this dog; he had evidently come to stay. We took him in and gave him a nice supper by the stove, for he was half starved and frozen. The next day, not seeing any advertisement in the paper, we decided to adopt him until we could find his owner; so we took him out and introduced him to our other dogs. We then named him "Rover."

Some time after we heard a noise in the garden, and, looking out, saw our dogs chasing a little white rabbit. When Rover saw this he ran into the garden—as we thought, to take a hand in the chase. No; he picked up the rabbit and brought it to us, not hurting it at all. Truly this was a kind deed, for he had never been trained, as far as we knew, for a retriever.



"AN OLD FORGE." BY VIRGINIA LIVINGSTON HUNT, AGE 14.

came to my memory during the last terrible blizzard, which reminded me of the awful sufferings of Napoleon's army in Russia. The doctor was my great-grandfather, whose name I am proud to bear.

HOME.

BY DOROTHY KERR FLOYD
(AGE 12).

(*Silver Badge.*)

WHETHER it be in the city,
So busy, noisy, and hot;
Or whether it be in the suburbs,
Or a humble country cot;

Or whether it be in the mountains,
Or close by the swift sea-foam:
The place where are father and
mother—
This place is surely home!



"GREAT-GRANDMOTHER'S HIGH CHAIR" BY
THEODORE S. FAUL, AGE 15.

GRANDMA'S HOME.

BY HATTIE MOORE (AGE 10).

WHEN I stay at grandma's,
In April and in May,
There is a little garret
Where I sometimes play.

And in this little garret
Is everything so gay,—
Even to little instruments
On which I sometimes play.

Then there is another place,
A dainty little room,
Where I keep my dollies' furni-
ture,
From bedstead down to broom.

Oh, dear, I wish I lived there!
But what would mama do?
I run on all her errands,
And tend to Baby Lu.

A KIND DEED.

BY AGNES LEE BRYANT (AGE 12).

THE United States has boasted many heroes, and one of the greatest ones, I think, is General Grant.

It was n't his kindness and good will in great things, but in little things.

One day he was riding in command of his army, when suddenly he halted, causing the whole army to swerve aside.

It was afterward found out that the cause was a little ground-sparrow's nest. He had rather put a whole army out of the way than to take a bird's life. I think



"A FIFTEENTH-CENTURY TYPOLIST MONUMENT." BY ELVIA VARRARO, AGE 16.

the same thing that was said of Captain Miles Standish may be well said about Grant:

"In battle he had the heart of a lion, but in caring for the sick and wounded he had the heart of a woman."

THE HOME OF MEMORY.

BY MARGUERITE STUART (AGE 17).

How oft, in the twilight that follows the day,
I dream of the home that I knew, far away!
The great world is wide, but there never can be
A spot where the days seem so happy to me.

As I speak, I behold the blue waves of the sea
Before me—so restless, so boundless, so free!
I toss back my head as I feel, even now,
The cool breath of heaven blow fresh o'er my brow.

Again I am counting the waves at my feet,
While the birds fill the air with their melody sweet.
There flowers always blossom, the sun always gleams,
The trees always shadow the home of my dreams.

So, longing, I dream of my home by the sea,
Where life seemed so bright and unclouded to me.
And, no matter where I may happen to roam,
My thoughts still return to the place I called "home."

A KIND ACT.

BY MARY GRAHAM LACY (AGE 13).

THE kindest act I know of was something Mrs. Roosevelt did a few years ago.

When Mr. Roosevelt was made President, I cut out

all the pictures of him and his family I could find in the newspapers and magazines.

One day, while I was playing with them, I lost my picture of Ethel. I was so distressed that father said, in fun, I had better write to Ethel and ask her for a picture. I thought he was in earnest, so I wrote to her. I was just a little girl then, so I first wrote the letter in pencil and then copied it in ink. Mother found the pencil letter a few days ago, and I will copy it here, as it tells the story better than I could remember it now:

"DEAR ETHEL: I am making a collection of your family. I have nine pictures of your father and four of Miss Alice, and I thought I had all; and I stood you up in a row along the paneling in the hall, and I did not know there was a little crack behind it, and you slipped down in the crack. I tried to get you out with a bonnet-pin, but I scratched so much paint off the wall that mamma made me stop; so will you please send me a picture of you? for I have looked through all the newspapers I could find, and I can't find any picture of you anywhere, and it spoils my collection of your family not to have any picture of you.

"Faithfully yours,

"MARY GRAHAM LACY."

When I had finished the letter I asked mother if I could send it. She said I could, because she knew I would be so disappointed if she did n't let me, and she thought by the time no picture came I would be more reconciled to my loss.

But about ten days later, to every one's surprise but mine, came a large photograph of Ethel, taken with her mother; and on one corner Mrs. Roosevelt had written, "Ethel Roosevelt and her mother."

I was so delighted I could hardly believe the picture was really mine; and mother said she thought Mrs. Roosevelt must be a very sweet, kind woman, for there were very few persons who would have taken that trouble just to save a little girl from disappointment.

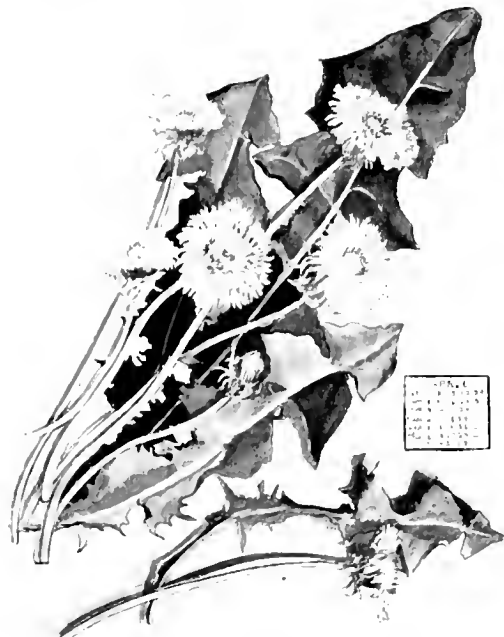

"DANDELIONS." BY ALICE SHIRLEY WILLIS, AGE 16.



"A FANCY FOR MAY" BY HELEN GARDNER WATERMAN, AGE 13.

COMING HOME.

BY RUTH BAGLEY (AGE 16).

(Honor Member.)

ABOVE the low hills sinks the sun in its glory,
And gilds the plowed fields with its own mellow
light.
The apple-boughs, laden with blossoms, are bending
To greet the bright dewdrops that herald the night.

High up in the tree-top a
robin is singing
His care-free, melodious
farewell to day.
But now twilight deepens, and
clear stars are twinkling,
And shines the pale moon
with its cool silver ray,

Which touches the clouds with
a glimmering whiteness,
As billows are crested with
flecks of bright foam;
And so, in the calm of the early
spring evening,
A lad and his father are go-
ing toward home.

Their cottage, which nestles
upon the broad hillside,
Is cheerily lighted, and
homelike, and warm.
The neat, simple rooms and
the savory supper
Will welcome the two com-
ing home from the farm.

When all is prepared, to the
door goes the mother,
And looks through the dark-
ness, and listens, until
the tinkling of cow-bells is
heard in the valley,
For Laddie is driving the
herd up the hill.

Contentment descends on the heart of the mother,
And joy that at last they may rest from their roam;
For, glad in the knowledge of labor completed,
Her lad and his father are coming toward home.

MY FRIEND THE SEA.

BY AMABEL JENKS (AGE 8).

I HAVE a very funny friend,
And he is named the Sea;
He rolls about with bow and bend,
As gentle as can be.

But sometimes he gets very mad,
And then he tears about;
And then I feel quite sad and say,
"He's really quite put out."

A KIND DEED.

BY MARY PEMBERTON NOURSE (AGE 13).

IN writing for the League, it seems to me to be preferable to write, if possible, about those who have taken part in some public event, or who are, for some other reason, known. At any rate, it is delightful to know of the little "kind deeds" done by the men who are everywhere honored.

Late one evening, in the fall of 1862, as the sun was sinking behind the beautiful Blue Ridge Mountains, leaving its radiant glow to spread out over the rolling hills and to be reflected in the east, Colonel Murray of the Confederate army came up the broad box-bordered walk which led to his home.

At this time he was not with his command, but was on sick leave; and as it was unsafe for him to stay at home, he had his tent at Foxville, about twenty miles away, sometimes coming to spend a night with his family.

On this occasion he was accompanied by a small body of Federal soldiers who had captured him a few hours before. The scouts who had captured him had taken him to General Patrick of the Federal army, who was now conducting him to his home.

General Patrick and Colonel Murray came up to the porch, where Mrs. Murray was sitting with a friend. Colonel Murray, after greeting them, said:

"Mrs. Murray, allow me to introduce my old friend, General Patrick of the Federal army."

A friendly talk followed; and then General Patrick, about to go, turned to Mrs. Murray and said:

"Ma'am, I have a favor to ask of you."

"What is it, general?" she asked.

"That you will keep Colonel Murray here as my prisoner."

And, turning to his captive, he said, "Now, Ned, stay at home."

In a few minutes he was galloping away with his men.



"MY FAVORITE FANCY." BY MARGARET DOBSON, AGE 10

This was not the only kindness shown to the Southern colonel by the Northern general; for when Colonel Murray was able to return to his command, at a time when it was almost impossible to make an exchange of prisoners, General Patrick effected his.

One striking thing in this story is the friendship which these West Point men held for each other, although their sense of duty had called them to opposite sides of our great civil struggle.

MY LITTLE HOME.

BY SUSAN WARREN WUBER (AGE 12).

It stands where western prairies sweep a thousand acres o'er,

'Mid autumn's waving grasses far as eye can see and more,—

The only patch of woodland for many a weary mile,—
The sweetest little farm-house, the quaintest country stile.

'T is a perfect little homestead,
With clambering rose and vine,
And a forest dense behind it
This little home of mine.

The birds, those happy songsters, sing their myriad melodies

From joyous little nests within the lofty forest trees.

Inside this little farm-house the hours like moments fly—

Before the springtime 's reached us, the summer 's passing by.

But 't is not the waving prairies,
Nor nature's joys that twine,
It is love that makes me cherish
This little home of mine.

A KIND DEED.

BY THODA COCKROFF (AGE 13).

THE sea was rough, and no wonder, for 't was the winter month of November. Many a wave had washed the decks of the steamship *St. Paul* as slowly, day by day, it made its way toward New York.

I had been seasick during the rough weather, and lay in my berth on this certain morning. My mother entered and asked if I had heard about the Russian Jew baby that was born in the steerage. "Really?" I exclaimed; "a baby born in the middle of the Atlantic Ocean?"

One gentleman said he thought we ought to do something for it.

So it was agreed that all who would should give a dollar to little "Paul," as we said the baby should be named, after the ship.

The money was collected, seventy dollars in all, and a Russian baron was asked to take it down, as he was the only one that could speak the mother's language. He took with him a wrapper that a lady had sent to the poor mother,



"A LAFIERCE FOR MAY," BY ISABEL G. HOWELL, AGE 14.

and some clothes for the little baby. A great many accompanied him.

We made our way down into the steerage. Dirty men of all nationalities crowded around us, curious to know why so many cabin-passengers were down there. We were told that the mother was not there, and were led to a clean little hospital room, where lay the mother with her little red baby.

The baron gave her the money, told her how much it was, and whom it was for.

The mother was over-whelmed with joy. She grabbed the baron's hand and tried to kiss it, but the baron drew back. Then



"MY LITTLE HOME," BY SARAH B. COOKE, AGE 11.

She grabbed the hand of the man who stood next. That was all. But that little baby, through the kindness of the passengers, did not come into America a pauper.

WINTER EVENINGS AT HOME.

BY PHYLLIS BROOKS (AGE 13).

At home, when evening shadows fall,
We listen to the north wind's call;
With curtains drawn, and bright lamp lit,
Around the cheerful fire we sit.

We do not care for howling storm
If we are happy, safe, and warm.

The kitten, "Thut," purrs on her mat
Without a thought of mouse or rat.

Our mother reads us fairy-tales,
And as the firelight dims and pales

We hear about King Arthur's knights,
Of noble deeds and splendid fights.

And as we watch the ruddy fire,
The sprightly flames leap high and higher;
We do not care the world to roam,
When mother reads to us at home.

NOTICE

Members should remember that, owing to preparation for Commencement Examinations and Vacation Season, the May Competitions close five days earlier than usual.

MY PRAIRIE HOME.

BY JESSICA N. NORTH (AGE 13).

(Honor Member.)

The roses open with the day
 Outside my cottage door;
 They drop the dewdrop jewels gay
 That all night long they wore.

The first pink rays of morning light
 That o'er the prairie fall
 Light up the blossoms red and white
 Along the eastern wall.

The breezes, laden with perfume,
 Over my garden sweep
 In through the window of my room,
 To wake me from my sleep.

My lovely, lovely prairie home!
 No marble palace fine,
 With lofty spire, and gilded dome,
 Could hold such charms as thine.

Give me my quiet prairie home,—
 I ask for nothing more,—
 My little prairie cottage
 With the roses at the door.



BY ELIA E. PRESLOW, AGE 16. (HONOR MEMBER.)

THE HOME OF BEAUTY.

BY EMMELINE BRADSHAW (AGE 13).

(Honor Member.)

The hills are bright with sunset hue,
 The river's voice is hushed and still;
 The brilliance 'gainst the evening blue
 Shines forth in light from hill to hill.
 O home of beauty, chaste and fair,
 The flow'r-clad mountains scent thy air!

The sun is set, the moon's soft light
 Doth bathe the fell with fairy sheen;
 And elfin spirits of the night
 In magic rings salute their queen.
 O home of beauty, chaste and fair,
 The moonbeams light thy silv'ry air!



"MY FAVORITE FANCY." BY RAY SAPP, AGE 17. (GOLD BADGE.)

The dawn is rising rosy-red,
 The river's breast is turn'd to gold;
 The shepherd's song rings overhead,
 The moon is dimm'd by morning cold.
 O home of beauty, chaste and fair,
 Your glory greets the perfum'd air!

BABY'S HOME.

BY ALMA C. JONES (AGE 12).

Baby's home is in a cot;
 All night long tucked up he stays;
 You see, he's such a little tot
 That he does not know our ways.

He has not yet received a name,
 So he is always called the Baby;
 But he will have one just the same,
 And in but a few days, maybe.

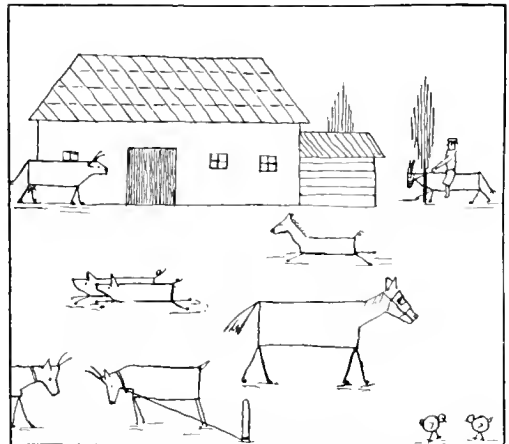

"MY FAVORITE FANCY." BY HAROLD SHEFFIELD VAN BUREN, JR., AGE 7. (SILVER BADGE.)



"A HEADING FOR MAY." BY RICHARD A. REDDY, AGE 17. (SILVER BADGE.)

HOME FROM THE CRUSADE!

BY MARGARET STUART BROWNE (AGE 15).

My prowess won me far renown:
Full many a knight I overthrew,
In lists of battlemented
town,
Or in the desert, bare and
brown,
Roofed only by the eter-
nal blue.

The victor's laurels here I
hold:
No infidel has scarred
my shield,
Undinted is its carven
gold;
My banner showed its
crimson fold
In many a glorious field!

Now I return with joy and
pride:
In yonder ivied castle
tower

My lady-love doth patient bide;
I hasten to my beauteous bride,
My glorious English flower!

How oft of her I dreamt, when far!
By desert pool, and Moslem dome,
I prayed for her, 'neath sun and star;
But now how glad my prayers are,
I come to her—and home!

HOME.

BY LELAND G. HENDRICKS (AGE 13).

I STOOD where Pleasure reigned as queen;
Sweet music filled the air;
I saw gay throngs, as in a dream,
And joy was everywhere,—
Yet 't was not home.

I stood beneath a palace dome,
'The dwelling-place of kings,
Where Luxury had built her throne,
And every wish took wings,—
But 't was not home.

I stood upon a lowly hearth,
Blest greatly from above
With sweet content, best gift of earth,
And simple peace and love,—
And this was home.

LETTERS.

It has been reported that one of the wild-bird pictures (March) labeled "Coot" should have been called a cormorant.

Now the League editor is not especially versed in coot and cormorant lore, and has to rely a good deal on the contributor's knowledge in these matters; but it is quite certain that a coot would feel offended to find himself labeled a cormorant, and vice versa. Hence it is to be hoped that the members of this multifarious and diversified family will be properly designated as often as possible, for the League ought not to get into any family quarrels with any of the numerous swimmers and divers, so many of whom have been long our faithful friends.

BAY CITY, MICH.

DEAR ST. NICHOLAS: It is now exactly two weeks and one day since my eighteenth birthday. I wanted to write and tell you of this sooner, but my eyes were bad; and, besides, I had several other important things on my mind. To-day, however, as I am alone, I will take the opportunity to thank you again for the beautiful gold badge which you sent me a year ago in June, and to say good-by. ST. NICHOLAS, I have been a member of the League for about three years, and during all that time

I have sent in only a very few contributions; I have not been as faithful as I should have been, and as I really intended to be, but I loved you none the less for that.

The gates are now closed upon me and I am left out in the cold, cold world; but may I not sometimes return,—may I not sometimes linger here outside the gates and look in upon the happy fields where I played in my childhood? Grant me this one wish, dear ST. NICHOLAS. And now, farewell!

Your old friend,

HILDA VAN EMSTER.

Other interesting and appreciative letters have been received from Lois Campbell Douglas, Madge Oakley, Laura M. Thomas, Francis Marion Miller, James M. Walker, Harry W. Hazard, Jr., Marjorie Soper, Arnold H. Bateman, Josephine Swain, Beth Baxter, Gladys S. Chamberlain, Eleanor Moore, Caro Kingman, Sybil Kent Stone,

Katherine Rutan Neumann, Dorothy Ochtman, Will Byrnes, Norman B. Keating, Fred E. Burger, Clarence Barry, Christine Schaff, Rosa Gahn, Frank P. O'Brien, Eliza Maclean Piggott, G. H. Kammerring, Ethel Dickson, and Martin Janowitz.

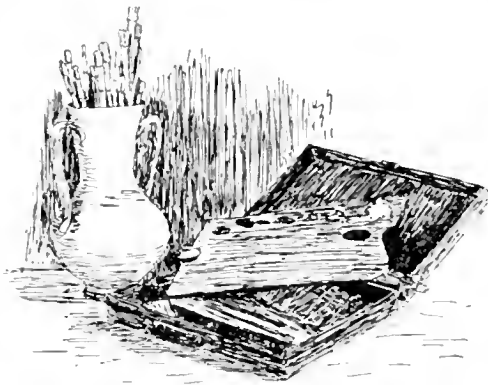

"MY FAVORITE FANCY." BY DOROTHY OCHTMAN, AGE 12. (HONOR MEMBER.)



"A HEADING FOR MAY." BY CHARLOTTE WAUGH, AGE 15. (SILVER BADGE.)

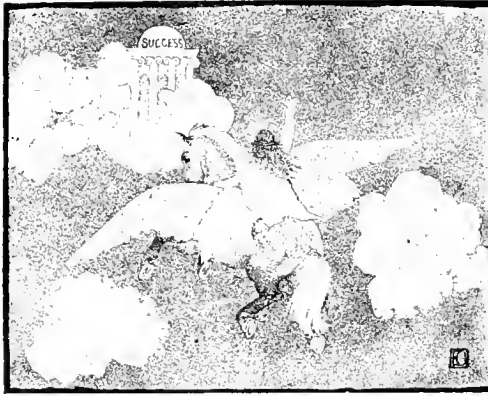

"MY FAVORITE FANCY." BY ELIZABETH OTIS, AGE 17. (HONOR MEMBER.)

THE ROLL OF HONOR.

No. 1 A list of those whose work would have been used had space permitted

No. 2 A list of those whose work entitles them to honorable mention and encouragement.

VERSE 1.

Harold R. Norris
Helen Van Dyck
France Lubbe Ross
Eleanor Johnson
John Guy Gilpatrick
Theresa Sniffin Leshet
Adelaide Nichols
Eleanor S. Wilson
Marguerite Sanderson
Wilbur K. Bates
Olive Mudie Cooke
Helen Leslie Follans-
bee
Margaret A. Brownlee
Nannie B. Nelson
Dorothy Schmidt
Maud Dudley Shackel-
ford

Agnes Churchill Lucy
Delia Alden Smith
Dorothy Gibson
Nannie Clark Barr
Dorothy McL. Yorke
Ethel Mitchell Dickson
Essex Cholmondeley
Catharine H. Straker
Constance Smith
Alice Blaine Dariosch
Frances Morrissey
Julia S. Ball
Russell B. Livermore
Jeanie Knowles
Mary Elizabeth Mair
Delphina L. Hammer

VERSE 2.

Marion Eleonore Lane
Clement R. Wood
Lester Jay Reynolds
Arthur Albert Myers
Helen Thayer
Marjorie K. Peck
Ruth Greenwood Lyon
Louisa F. Spear
Marguerite M. Jacque
Twila A. McDowell
Gladys Nelson
Margaret Eugenie Ste-
vens
Daisy Errington Bret-
tell
Elizabeth R. Marvin
Mary Winslow
Mary M. Dabney
Ruth M. Hapgood

Edith J. Minaker
Gladys M. Manchester
Constance Buell
Marion C. Stuart
Susan J. Appleton
Helen Wyman
Kathryn Johnstone
Josephine E. Swann
Miss Lucia Beebe
Marie Armstrong
Eleanor R. Chapin
Lucile D. Woodling
Grace Leslie Johnston
Theresa R. Robbins
Hannah K. Glover
Dorothy Coffin
Margaret Brooke
Ralph Harrison
Gracie Conner

PROSE 1.

Phyllis M. Clarke
Francisca Blainu
Margaret McElroy
Ray Murray
Alma Wiesner
Marian Phelps van
Buren
Miriam W. Cragin
Bertha Torchiani
Jessie Strauss
Dorothy Cooke
Marianna Lippincott
Constance Taylor
Imogene Avis Tatum
Helen Lathrop
Gladys M. Davis
Elizabeth Knowlton

PROSE 2.

Camille Adams
Margaret Hudson
Dorothy Goldthwait
Thayer
Margaret Spahr
Theda Kenyon
Isabel Weaver
Ruth Adler
Charles Thorburn van
Buren
Charlotte Brinsmade
Percy V. Pennybacker
Elaine Sterne
Roy Howard Arms
J. Dunham Townsend
John L. Taylor

Mary C. Fuller
Eleanor Moore
Lucy K. Browning
Arthur N. Neht
Helen Hodgman
Alice Schiff
Ruth E. Wilson
Dorothy Butes
Ruth Fisher
Mary Louise Smith
Lois Lovejoy
Irene Rose Weil
Gwendolen Gray Perry
Dorothy Stanion
Kenneth Dorrien
Jumetta Stephen
Gwendolen Tugman
Cornelia R. Hinkley
Volant Vashon Ballard
Abby Duming
William Wehage
Hilda S. Boeghold
Elsie F. Weil
Iola Kandelrock
Muriel Bennett
Edith Carey Owens
Fvy Varian Walshe
Maysie Regan
Ethel Berrian
Mildred Newman
Frank Bechtel
Vincent Imbrie
Sylvana Blumer
Ruth Pennybacker
Josephine Freund
Eugenie Powdermaker
Helen E. Bartlett

DRAWINGS 1.

Vera Demens
Mellville C. Levey
Archibald MacKinnon
Hugh Spencer
Helen M. Brown
Kathleen Buchanan
Nancy Barnhart
I. J. Dis her
Phoebe Hunter
Robert Edmund Jones
Sidney Moise
Ruth Collins
Frank P. O'Brien
Dorothy Adams
Katherine Dulcebella
Barbour
Stasito Azoy
Oscar Schmidt

Elise Donaldson
Florence Gardiner
Richard F. Babcock
John Andrew Ross
Margery Bradshaw
Clifford Jackson
Cordner H. Smith
Clinton Brown
Roy Chapman
Genevieve A. Ross
C. Hart Bradley
S. Davis Otis
Emily W. Browne

DRAWINGS 2.

Evelyn Buchanan
Roger K. Lane
Lucy B. Mackenzie
Phyllis Ottman
Everard McAvoy
Ruth Mouser
Alberta A. Heintmiller
Wesley R. DeLappe
Carrie May Jordan
Ralph M. Crozier
Helen Stafford
Kate Sprague De Wolf
Mary Ellen Willard
Mark Curtis Kinney
Morton Newburger
Marion H. Tuttil
William Byrnes
Lillie Lemp
Everett Williamson
Genevieve A. Ledger-
wood
Esther Parker
Leonie Nathan
Gladys L'Estrange
Mary Hazelune Few-
smith
Alice Whitton
Ewing Amos
Marcia Hoyt
Katharine A. Page
Katherine M. Keeler
Anita Moffett
William W. Westring,
Jr.
Irving Beach
Margaret W. Peck
Mervyn Joy
Claudia Paxton Old
Mary Williams Bliss
Aline Macdonald
D. Merrill
Mildred Andrus
Harriett Bradley
Louise Garst
Beatrice Darling
Jeannette Dair Gray
Katharine N. Rice
Ethel Messervy
Herman L. Schaffer
Bessie Shields
Mary Yadowsky
Rebecca Newcomb
Roy E. Hutchinson
L. Fred Clawson
Elinor Colby
Marion Shumway
Julius Fay
Josephine Holloway
Ivan Black
Rivington Pyne
Margaret B. Richard-
son
Frances Jeffery
Alan Adams
Helen Allen
Lucy B. Scott
Mary A. Jones
Alice Noble
Eric Cushman
Esther F. Aird
Carolyn Williams
Katharine Havens
Mary Falconer
Amy O. Bradley
Mildred E. Williams
Robert A. Heunstin
William C. Engle

Katharine Duer Irving
Margaret Lantz Dan-
tiell
Louise Richer
Marian Walter
Walter Heller
Marion Fitch
Marian Wright
Mary Klauer
Stanley T. Curran
Robert H. Gibson
Stephanie Balderston
Jack O. Melveney
Flora Shen
John Comly White
Sarah Lippincott
Lawrence Cowll
Margaret B. Wood
Rachel Wyse
Walter Burton Nourse
William M. Bayne
Katharine Marshall
Hattie Cheney
Helen Baker
Edwards Adams Rich-
ardson
Ella Hotelling Tan-
berg
Agnes Hayne
Mary Ellen Willard
Mark Curtis Kinney
Kosamond Cadman
Eleanor Keeler
Alice Trimble
Janet Dexter
Clinton Brown
M. Harrison
W. R. Wilson
Tom Brown
Ethel Irwin
Grace F. Slack

Evangeline G.
Coombes
John D. More
Dorothy R. Halkett
C. H. Pangburn
William Warfield
Ralph L. Bell
Caroline Dudley
Helen Johnson
Cornelius Cannon
Granville L. Williams
Joseph S. Webb
Dorothy Hungerford
Robert Edward Fith-
ian
Everett Mitchell
Kathleen Brown
Albert L. Schoff
Madison Dyer
W. Caldwell Webb
Robert S. Treat
Marian Rowe
John Gatch
Morris Douglas
Margaret Wilkins
Clarence A. Manning
Alice du Pont
Anna Clark Buchanan
Lawrence Day
George Grady, Jr.
E. D. Wall
Frederic C. Smith
Isadore Douglas
Constance L. Bottom-
ley
Amy Peabody
George Ashley Long,
Jr.
Helen D. Long
Dorothea da Ponte
Williams

PHOTOGRAPHS 1.

Bradley Z. Coley
Piero Colonna
Robert S. Platt
Donald Armour
Mary R. Paul
John B. Lowry
Edward Harper Lasell
J. Gordon Fletcher
Barbara O. Benjamin
Marjorie C. Newell
Dorothy Weir
Arthur H. Wilson
Harold Fay



"MY FAVORITE FANCY." BY LYLIE FRINK, AGE 14.

PUZZLES 1.

Henry Morgan Brooks
Harry W. Hazard, Jr.
John Farr Simons
Leonard Barrett
Mildred W. Weston
Isabel Weaver
Elizabeth Beal Berry
Catharine E. Jackson
Leslie Spencer
Julia Dorsey Musser
C. D. Tait
Terry B. Martin
Grace E. Moore
James B. Diggs
Irwin S. Joseph
Arthur Rubeck
Edmund P. Shaw
Agnes R. Lane
Fred E. Berger

PHOTOGRAPHS 2.

Kenneth Horner
G. Huntington Wil-
liam, Jr.
George Mastick, Jr.
William C. Wright, Jr.
Miles W. Weeks

PUZZLES 2.

Esther Jackson
Eleanor L. Halpin
Mary Parker

PRIZE COMPETITION No. 68.

THE St. Nicholas League awards gold and silver badges each month for the best poems, stories, drawings, photographs, puzzles, and puzzle-answers. Also cash prizes of five dollars each to gold-badge winners who shall again win first place. This does not include "Wild Animal and Bird Photograph" prize-winners.

Competition No. 67 will close May 15 (for foreign members May 20). The awards will be announced and prize contributions published in ST. NICHOLAS for August.

Verse. To contain not more than twenty-four lines. Title: to contain the word "Waves."

Prose. Story, article, or play of not more than four hundred words. Subject, "A Funny Incident."

Photograph. Any size, interior or exterior, mounted or unmounted; no blue prints or negatives. Subject, "The Playground."

Drawing. India ink, very black writing-ink, or wash (not color), interior or exterior. Two subjects, "A Study of Foliage" (from life) and a Heading or Tailpiece for August.

Puzzle. Any sort, but must be accompanied by the answer in full, and must be indorsed.

Puzzle-answers. Best, neatest, and most complete set of answers to puzzles in this issue of ST. NICHOLAS. Must be indorsed.

Wild Animal or Bird Photograph. To encourage the pursuing of game with a camera instead of a gun. For the best photograph of a wild animal or bird taken in its natural home: First Prize, five dollars and League gold badge. Second Prize, three dollars and League gold badge. Third Prize, League gold badge.

RULES.

ANY reader of ST. NICHOLAS, whether a subscriber or not, is entitled to League membership, and a League badge and leaflet, which will be sent on application.

Every contribution, of whatever kind, must bear the name, age, and address of the sender, and be indorsed as "original" by parent, teacher, or guardian, who must be convinced beyond doubt that the contribution is not copied, but wholly the work and idea of the sender. If prose, the number of words should also be added. These things must not be on a separate sheet, but on the contribution itself—if a manuscript, on the upper margin; if a picture, on the margin or back. Write or draw on one side of the paper only. A contributor may send but one contribution a month—not one of each kind, but one only. Address:

The St. Nicholas League,
Union Square,
New York.

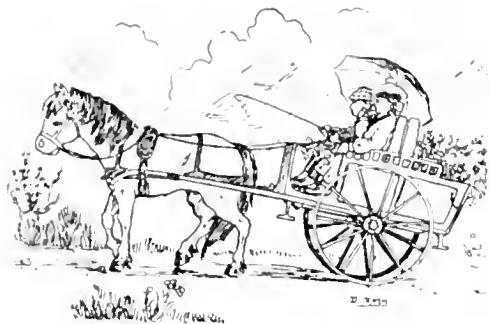

"MAY." BY BEN ROTH, AGE 15.

Frances Carrington Edward A. Niles Isabel Creighton
Bruce Simonds T. Burdick Frank Beatrice F. Cogle

LEAGUE NOTES.

THE "Canadian Youth" is a little paper devoted "to boys, their sports and hobbies." It is published by Frank O. Mortley and C. B. Whitney of Toronto, Canada, and is a creditable amateur sheet. It opens with an interesting story, and is neat and workman-like in appearance.

Florence C. Clark, Willoughby, Ohio, and Edith Helmcken, 23 Langley Street, Victoria, B.C., wish to exchange postal cards.

Edna Behre asks, "Do you ever write us about our contributions?"

Not often. The task would be too great. Now and then, when something of very unusual merit has been received, which for one reason or another could not be used, the editor has written to explain why. But it would be impossible to criticize contributions after the manner of school work. The League is a great comparative school, and the benefits gained by comparing one's work with the work of others, and in trying to understand and to rectify the shortcomings.



JUDY

"MY FAVORITE FANCY." BY MARY STEWART CLAPLIN, AGE 5.

Elsie F. Weil wishes to say that her age is 15 and not 14 as set down with her story published in the March issue. Well, perhaps it was the printer, perhaps it was the editor, perhaps it may even have been Elsie herself who did not write perfectly plainly. Let us all blame it on one another and be happy—and charitable.

H. T. T. and others write that they have lost their prize badges and would like them replaced. This cannot be done. A badge once lost is like any other treasure. It's gone. Replacing prize badges would eventually lead to complications and trouble. Take care of your badges, once earned. The earning is hard enough to make the winner very careful.

Edna Mead and others ask, "How should MSS. be addressed when sent to magazines in the regular way?"

Simply, "Editor of the Magazine, City, State." The MS. should bear the author's address and number of words, just as if prepared for the League, omitting only the age and indorsement. It is one object of the League rules to teach the young writer and artist how to prepare their work for the editor.

The words "Honor Member," in connection with any contribution, mean that the contributor has already won a gold or cash prize.



"SPRING." BY MARJORIE NEWCOMB WILSON, AGE 12.



"TAILPIECE." BY EDITH CLEMENT, AGE 13.

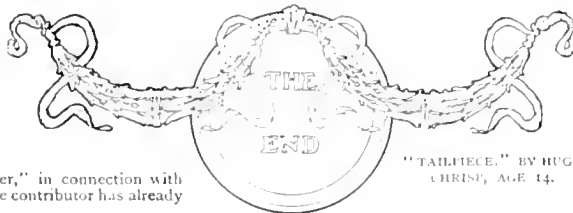

"TAILPIECE." BY HUGH CHRISP, AGE 14.

BOOKS AND READING.

OLD FRIENDS IN NEW DRESS. It is a charming thing about books that they have the power of appearing in more than one character without ceasing to be the same. To find a story one has read in some unadorned Quaker-like edition, presented anew in the gala costume of fine binding, broad margins, and appropriate illustrations, is to renew acquaintance with an old friend grown prosperous without becoming distant. And it is one of the benefits of making friends with the best books that they are ever appearing in some new and taking garb. To replace your battered copy by a better copy is not an act of disloyalty, since the soul of the volume remains the same.

MILESTONES ON THE ROAD TO LEARNING. To see whether one makes progress there must be a point from which to measure. If you row out into a lake during a thick fog, you will find it hard to tell either how fast you are moving, or what point you have reached. For this reason it is well to re-read some book you liked a few years ago, and to see whether you are a person of the same tastes and opinions as you were during the earlier reading. The result may be very pleasant. You may find you are not only older, but that you have learned much and advanced in wisdom; for, of course, the book does not change. But do not be discouraged if you can see no change in your liking for the book; it may be that the volume chosen is one that is "not of an age, but for all time."

The same test may be used in one's school-work; going over old text-books will often make a boy or girl understand how much has been gained since the familiar volumes were studied. Let us recommend this to the discouraged.

A BIOGRAPHICAL DICTIONARY. ONE of the most helpful books to keep upon your table, ready to be consulted as you read other books, is a biographical dictionary. Then, when you come to some historical character about whom your knowledge is a little faded, it will require but a moment to refresh your memory and make your reading more intelligent. You have a right to the acquaintance of these

distinguished men and women, and should keep up at least friendly relations with them, if for no other reason than in gratitude for what they have done to make your life pleasant.

FIRST AND SECOND TIMES OF READING. IN reading good poetry or well-written prose it is a good plan to go straight through, to make sure that the main story is well understood. Then, if your interest is great enough to make you wish for more information, read the notes, introductions, comments, and explanations during a second and more minute reading. All the best literature has been carefully studied by men well fitted for the work, who have told us whatever is necessary to a full understanding of the authors' meaning. One of the advantages of Sunday-school work is in learning how much is necessary to be known before one may be sure of having fully comprehended a passage in the Scriptures. In the same way, a college education is valuable chiefly in teaching one how to study.

"GETTING INTO SOCIETY." THE question of making the right friends is very important to us all, and we should all try to know the very best society open to us. The most distinguished society in the whole world, that containing the noblest, wisest, and most interesting men and women of all ages, invites you to its company within the covers of books. And you do not have to make their acquaintance by chance, for they are all known and valued for you. What shall we think, then, of the girl or boy who will not take the trouble to seek these friends?—to invite them to dwell in the home and become daily companions?

You may be sure that the great authors are *all* worth knowing. Which will become your most intimate chums no one can tell; but do not make the mistake of thinking they did not write to please you, or that because a book is by a great man it must be obscure—hard to understand. The contrary is most likely. Because of his simplicity, largely, Homer is thought by many the greatest of all poets. The Hebrew prophets in the Bible are as simple in speech as

they are grand in thought, powerful in language and imagery.

Coming to our own day, have you ever read Tennyson's story of the "Sleeping Beauty," and noted its simple language? Here is the breaking of the charm :

A touch, a kiss! the charm was snapt,
 There rose a noise of striking clocks,
 And feet that ran, and doors that clapt,
 And barking dogs, and crowing cocks ;
 A fuller light illumined all.
 A breeze through all the garden swept,
 A sudden hubbub shook the hall,
 And sixty feet the fountain leapt.

All of you young lovers of fairy-stories who know the romance of that old legend should read Tennyson's telling of the story—and then you will read more of Tennyson, to your lasting enjoyment and betterment.

FLY-LEAF MEMORANDA. EVERY now and then you will find in some periodical an item relating to the subject of a book in which you are interested. It is a good plan to enter on the fly-leaf a reference to this passage, so that you may find it again when needed. Such notes neatly written in pencil do no harm, and will often save you much time. You may in the same way make notes of the numbers of pages in which you have been specially interested. A correspondent writes to us, asking whether we recommend "marking books." To this extent we certainly do, provided the book is not so fine an edition that it should be kept as spotless as can be. Besides, *very light* pencil notes can be removed in a moment without harm to any page. But the marking of books that extends to disfiguring them will never be done by any one who realizes how long a good book may continue to delight new readers, and to bring them help in right living and thinking.

HOW ABOUT YOUR SCHOOL-BOOKS? BOOK-PLATES are always interesting; won't some of our readers let us see what designs they have adopted? If there were no other reason for having a book-plate, it would be worth while as a neat and harmless way of marking property. Have any of you ever seen a school-book with the owner's name scrawled on both covers, all over the fly-leaves, and in half a dozen other

places where the clear, white, unsoiled paper would have been far more attractive? You need not keep your school-books in boxes lined with cotton; but—why throw them into any odd corner, or use them as if they were riatas? They are books, after all, and many of the modern text-books are excellent pieces of book-making—some of the editions of Cæsar and Virgil, for example, are good enough to merit a place on your library shelves. Or, if you don't care for them yourselves, give them to some other student, and help to educate another boy or girl. One wishes at times that some of the old scholars of the Middle Ages could come to life again for the purpose of seeing how plentiful in our day are the volumes that were once so highly treasured. In some schools pupils are fortunately taught how this has come about, and to appreciate the true use and worth of the store of learning now everywhere available.

"IF I HAD TIME." THE month of May is near enough to vacation to make plans for the days when you may dispose of your own time more freely. "If I had time" ceases to be a good excuse in the summer months for many of you. Won't you arrange to read, this summer, that book you have always "meant to read" when you had time?

A BOOK AND ITS ARMOR. IN the modern method of binding books there is one weak point, and the owner should bear this in mind. The joining of the pasteboard cover to the leaves is very likely to give way if the book is not properly cared for, and if it once begins to separate there, its early destruction is sure. Therefore be careful not to force the cover down flat, nor to let the book fall. The covering case is the book's armor against the accidents of its life, and should be carefully preserved. Once loose in the cover, the weight of the leaves soon wears out the joining. A good workman being known by the condition in which he keeps his tools, a lover of books should take pride in keeping his mental weapons ready for easy use. Putting on workaday coats of stout paper is an excellent plan in the case of all books often handled. There are several sorts of adjustable covers for sale by all stationers, and these are made of good strong material and make excellent overalls.

THE LETTER-BOX.

MY DEAR ST. NICHOLAS: Have any of your readers ever seen a little dog with a broken leg which is tied up in a splint? I send to you his picture, which is very interesting, but at the same time sad. As soon as his leg



BILLY.

was broken we took him down to the veterinary hospital, where they set his leg. Afterward we had to carry him around for three weeks before his leg got well. He could hobble about on a level, but not go up and down stairs. He was four months old when it happened, and his name is "Billy."

Your sincere reader,

SOPHY BISPHAM (age 9).

TO THE EDITOR OF ST. NICHOLAS,

Dear Madam: In looking over some old letters recently I found a number from the late Frank Stockton, which brought to mind that I was a contributor to ST. NICHOLAS back somewhere in the seventies. The boys and girls who read ST. NICHOLAS then are middle-aged men and women now, and I wonder whether the boys and girls of the present time appreciate ST. NICHOLAS as highly as the juveniles did twenty-five years ago. One of the boys of that time told his aunt the other day what this periodical was to him when he was a little country boy living on an isolated farm situated on the highest point of the State, having but little society, few books, and without a library, even of the Sunday-school sort in a primitive community. As a Christmas gift his aunt subscribed to ST. NICHOLAS for him, and for three or four years he looked forward to the monthly feast of good things that never failed to come on time. The nearest post-office was four miles away, and if a neighbor

going to the village did not bring him the precious parcel, he traveled eight miles to get it! After he had finished, his brothers enjoyed the undiminished feast, and then passed it along to other hungry boys who had no generous city aunt.

At length a time came when he waited in vain for dear ST. NICHOLAS, and it was Christmas-time, too. Perhaps there was a delay of the mail. The snow was deep and heavy, and everything was snowed except the great high hill he lived upon. Christmas passed without its usual cheer: something very dear to the boy's heart was lacking, and, alas! the lack was never made up to him, though, encouraged by that same aunt, the country boy went to college and got his degree.

"Oh, my dear boy, why did you not write and tell me how much ST. NICHOLAS was to you?" said the aunt after her nephew had told his story, the half of which has not been told here.

"I could n't, I felt so wretched; I simply could n't say anything of what I felt," he replied. Now, I hope that if there are any city aunts subscribing to ST. NICHOLAS for their young country nephews they will keep up the subscription indefinitely and thereby escape the regret of

Yours sincerely,

ANNIE E. DE FRIESE.

MADRID, SPAIN.

DEAR ST. NICHOLAS: I have taken you for five years and like you very much. My favorite tales are "Quicksilver Sue," "King Arthur," "Queen Zixi of Ix," Nature and Science, etc. I have a horse called "Plata" (Silver), two little white Galfa birds, two very tame canaries and thrushes. We have a country house, which formerly belonged to the Dukes of Osuna. It is a lovely place.

We (my brothers, age 12 and another age 4) have our own little gardens. The 27th of November, a Sunday, it snowed all night, and in the morning a white carpet of snow covered the ground, such as Madrid has not seen since the winter of 1866. We snowballed (for the first time) and amused ourselves immensely. All the telegraph posts fell down.

Yours truly,

IGNACIO BAUER (age 14).

BAY CITY, MICH.

DEAR ST. NICHOLAS: I thought that I would write you a letter, as I have never seen one from Bay City before. My grandma gave you to me for a Christmas present for two years, and my father has given you to me for a year. I enjoy reading you very much; so do my mother and my father.

The stories that I like to read are "Denise and Ned Toodles," "Elinor Arden, Royalist," and "How Two Dorothys Ran Away from the British." I also like to read the stories and poems in the League department. I have tried to write something, and I got my name in the Roll of Honor.

Last summer I went away to visit, and on my way home I stopped at Niagara Falls. I saw Goat Island, Three Sister Islands, and Luna Island. It is a wonderful place.

Hoping my letter is not too long, I remain,

Your sincere reader,

DOROTHY DUNNING (age 11).

THE RIDDLE BOX

ANSWERS TO PUZZLES IN THE APRIL NUMBER.

GEOGRAPHICAL SQUARES. I. 1. Durand. 2. Verdun. 3. Orkney. 4. Calais. 5. Manila. 6. Punjab. II. 1. Berlin. 2. Pilsen. 3. Leshé. 4. Moscow. 5. Jordan. 6. Norway. III. 1. Balkan. 2. Soudan. 3. Jasper. 4. Fulton. 5. Yellow. 6. Selwyn. IV. 1. Nantes. 2. Baikal. 3. Hebron. 4. Madrid. 5. Saugus. 6. Merced. V. 1. Nippon. 2. Kenton. 3. Baglen. 4. Haynau. 5. Persia. 6. Corrib.

DOUBLE ZIGZAG. "Nicholas Nickleby" and "David Copperfield." **CROSS-WORDS:** 1. London. 2. Signal. 3. Active. 4. Behind. 5. Sounds. 6. Lactic. 7. Parrot. 8. Vesper. 9. Saipan. 10. Sinner. 11. Copper. 12. Skiffs. 13. Salmé. 14. Regret. 15. Emblem. 16. Synods.

CONNECTED SQUARES. I. 1. Beat. 2. Each. 3. Ache. 4. Then. II. 1. Here. 2. Now. 3. Rope. 4. Ewer. III. 1. Peal. 2. Ergo. 3. Aged. 4. Lode.

TO OUR PUZZLERS: Answers to be acknowledged in the magazine, must be received not later than the 15th of each month, and should be addressed to ST. NICHOLAS Riddle-box, care of THE CENTURY Co., 33 East Seventeenth St., New York City.

ANSWERS TO ALL THE PUZZLES IN THE FEBRUARY NUMBER were received, before February 15th, from William E. Hart—Frances Hunter—Nina H. Weiss—F. Adelaide Hahn—Gladys Cherryman—William Munford Baker—Emily P. Burton—J. Alfred Lynd—"Chuck"—"Katiejam"—Grace Haren—Florence DuBois—Mildred C. Jones—Jo and I—"Alli and Adi"—Marguerite Hyde—Katharine Whitney—Elizabeth D. Lord—Dorothy Rutherford—Paul K. Deschere—Nessie and Freddie—Neil A. Cameron—Francis M. Weston, Jr.—Marjorie Mullins.

ANSWERS TO PUZZLES IN THE FEBRUARY NUMBER were received, before February 15th, from M. Reid, 1—R. Dechart, 1—L. Clark, 1—M. M. McKinney, 1—T. Beus, 1—E. Philips, 1—M. Rupprecht, 1—R. Williams, 1—P. R. Zimmole, 1—S. Thordike, 1—Frederica K. Mead, 7—W. F. Cooper, 1—M. McCulloch, 1—R. Rose, 1—F. Hayes, 1—L. M. Williams, 1—Elsie Nathan, 6—R. C. Hammer, 1—J. Bruce, 1—R. H. Gaul, 1—M. F. Pierson, 1—Dorothy Fisher, 4—L. Holberg, 1—J. Lambkin, 1—William Chauvenet, 3—Ella J. Sands, 6—William H. Bartlett, 7—J. Rankin, 1—H. Rogers, 1—P. Erben, 1—E. Heald, 1—G. Cleveland, 1—E. Gnaedinger, 1—D. M. Fargo, 1—Caroline Kay Servin, 7—P. Cohen, 1—Lois Treadwell, 6—E. Fox, 1—R. Watson, 1—S. Miller, 1—S. Moczygenba, 1—M. Cooke, Jr., 1—K. and C. Newbold, 3—M. Dimond, 1—S. J. Lawellin, 1—D. Cathell, 1—I. M. Warden, 1—Elisabeth Morris, 7—M. McCall, 1—R. Tinker, 1—R. B. Thomas, 1—Two Little Maids, 5—E. Nelson, 1—John Orth, 4—Marian A. Smith, 7—No Name, Hackensack, 1—Mary E. Askew, 6—J. Shapiro, 1—Florence Goldman, 4—F. Nicol, 1—E. Bunnell, 1—E. F. Oswald, 1—J. Crystal, 1—Benjamin L. Miller, 7—Harriet Bingham, 5—B. Snowden, 1—St. Gabriel's Chapter, 6—Emily Smith, 6—Carl Philipp, 5—M. L. Powell, 1—G. Lincoln, 1—D. T. Graves, 1—Jeannie K. Sampson, 7—P. S. Lamb, 1—Andree Maite, 5.

CONCEALED NAMES.

(Silver Badge, St. Nicholas League Competition.)

ONE feminine name is concealed in each couplet.

1. Do not deface or mar you wall;
"T will mischief make, both spring and fall.
2. I win if Redway will play fair;
If not, to win I do not care.
3. Here 's some real ice which came from the lake,
Three feet by five feet—a nice cold cake.
4. She lent me a dollar, bright and new;
She is not a cheat and her faults are few.
5. Oh, do, Rastus, stop that noise;
Seems to me you 're naughty boys.
6. Cousin Ed, it had a roar
Louder than a big, wild boar.
7. "I am, you are, thou art,"
Sang little Billy Hart.
8. When France sold to us the wide, wide West,
We bought it right quick, and now see 't was best.

CATHARINE E. JACKSON.

BEHEADINGS AND CURTAILINGS.

(Gold Badge, St. Nicholas League Competition.)

WHEN the following words have been rightly beheaded and curtailed, the four remaining letters may (sometimes) be rearranged so as to form a word. When these sixteen new words have been written one below another, the final letters will spell the name of a great general. Example: Behead and curtail scribbles, and make to weary. Answer, w-rite-s, tire.

1. Behead and curtail to alter, and leave to suspend.

MULTIPLE CROSS-WORD ENIGMA. Pompey, Cicero, Caesar, alpaca, monkey, ocelot. — **CHARADE.** Malay.

DOUBLE BEHEADINGS AND CURTAILINGS. Last-ride. 1. Current, err. 2. Le-ah-ong, and. 3. Instead, set. 4. Certain, tar. 5. Sa-due-ss, end. 6. Sugar-ed, rag. 7. Con-tin-u-tan. 8. Ab-cie-nt, ice. 9. Band-its, dim. 10. Ac-rea-ze, ear.

A ZIGZAG. Martin Fish-her. **CROSS-WORDS:** 1. Moisture. 2. Basilisk. 3. Terminal. 4. Ecstatic. 5. Palliate. 6. Renowned. 7. Handcuff. 8. Reporter. 9. Doubloon. 10. Culpable. 11. Nautilus. 12. Forsaken. 13. Inherent. 14. Lemonade. 15. Rambling.

ILLUSTRATED NUMERICAL ENIGMA. "Consider the lilies of the field, how they grow."

DOUBLE ZIGZAG. Keats, Lamia. **CROSS-WORDS:** 1. Keel. 2. Peat. 3. Atom. 4. Str. 5. Soda.

2. Behead and curtail articles used in school, rearrange, and make a story.
3. Behead and curtail an angle, rearrange, and make the name of a wicked emperor.
4. Behead and curtail a certain fruit, rearrange, and make another fruit.
5. Behead and curtail fetches, and leave a circle.
6. Behead and curtail a human being, rearrange, and make a lovely flower.
7. Behead and curtail certain joints of the body, rearrange, and make a sudden calamity.
8. Behead and curtail a moderate gallop, rearrange, and make a volcano in Sicily.
9. Behead and curtail a reply, rearrange, and make fresh tidings.
10. Behead and curtail a king around whose name many legends cluster, rearrange, and make a book of the Bible.
11. Behead and curtail active, rearrange, and make one of the sons of Jacob.
12. Behead and curtail a comrade, rearrange, and make part of a harness.
13. Behead and curtail to hire, rearrange, and make a squad.
14. Behead and curtail greatly, rearrange, and make a common seasoning.
15. Behead and curtail beaches, rearrange, and make a very brave man.
16. Behead and curtail certain nuts, and leave a grain.

A CARGO OF TEA.

EXAMPLE: Take tea from a snare, and leave a blow. Answer, T-rap.

1. Take tea from a piece of furniture, and leave qualified.
2. Take tea from a legend, and leave a beverage.
3. Take tea from a money-box, and leave sick.
4. Take tea from a sharp pain, and leave a fireside.
5. Take tea from labor, and leave to lubricate.
6. Take tea from to drill, and leave a downpour.
7. Take tea from a cord, and leave a beverage.
8. Take tea from a quick pull, and leave a wizard.
9. Take tea from part of a wheel, and leave wrath.
10. Take tea from sour, and leave science.
11. Take tea from disloyalty, and leave sense.

ANGUS M. BERRY.

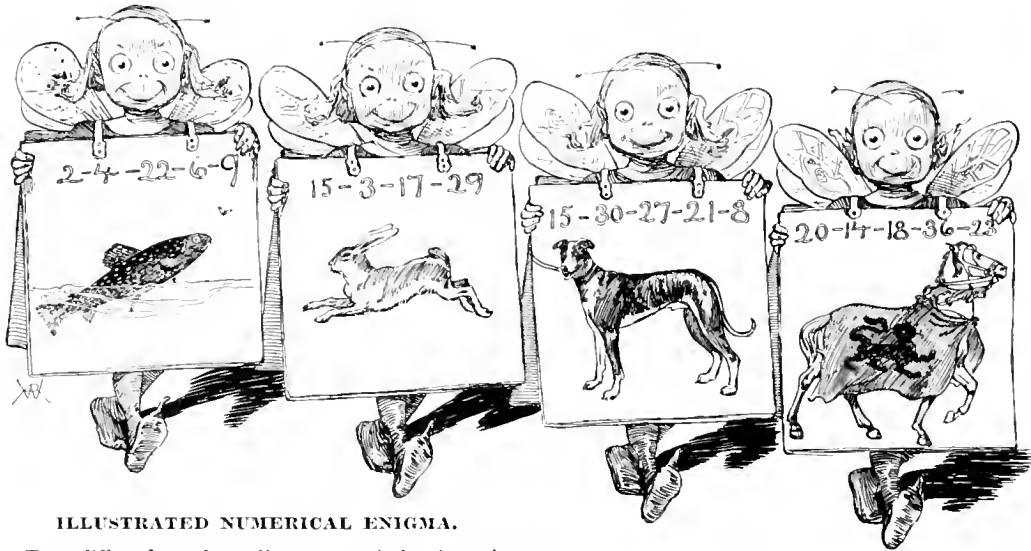

ILLUSTRATED NUMERICAL ENIGMA.

THIS differs from the ordinary numerical enigma in that the words forming it are pictured instead of described. When the eight objects have been rightly guessed, and the letters set down in the order given, the thirty-six letters will form a proverb.

CONNECTED SQUARES.

(Gold Badge, St. Nicholas League Competition.)

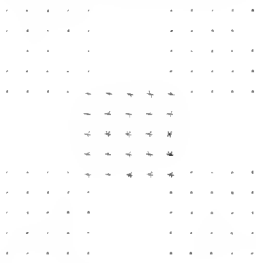

- I. UPPER LEFT-HAND SQUARE: 1. A lid. 2. A tropical fruit. 3. Crimes. 4. Incident. 5. Reposes.
- II. UPPER RIGHT-HAND SQUARE: 1. To depart.

- 2. A joint in the body. 3. To diminish. 4. One who votes. 5. Pitchers.
- III. CENTRAL SQUARE: 1. A gardening implement. 2. Makes a low and continued murmur. 3. Tapestry. 4. A play. 5. A trial.
- IV. LOWER LEFT-HAND SQUARE: 1. The capital of Holland. 2. A deputy. 3. A genius. 4. A confederacy. 5. Short jackets.
- V. LOWER RIGHT-HAND SQUARE: 1. Often heard at foot-ball games. 2. Neither more nor less. 3. Riches. 4. Big. 5. Frozen rain.

EDNA KROUSEAGE.

CHARADE.

(Silver Badge, St. Nicholas League Competition.)

My first is in pen;
 My second is men;
 My third is in faint;
 My whole is a paint.

MASON GARFIELD.

ANAGRAM.

A FAMOUS British statesman:
 LIST! MAIL W. T. A GOLDEN EWER.

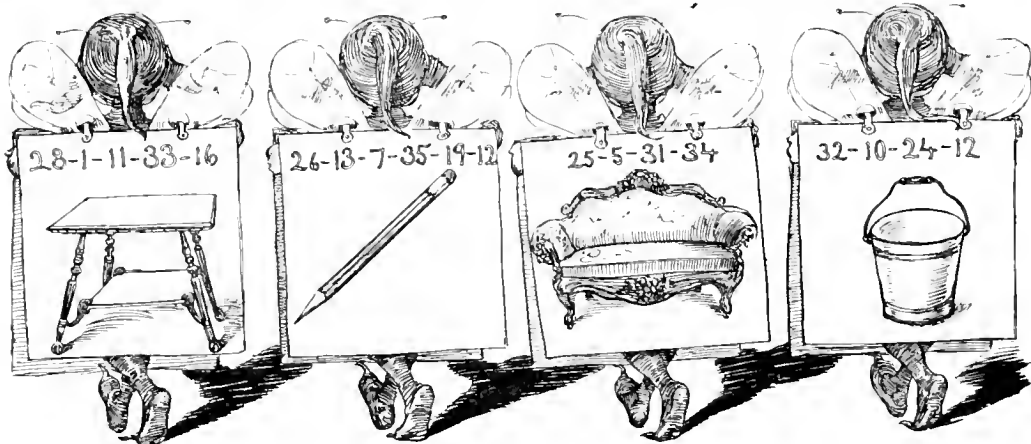



- Wm Jacobs -

"THEN SHE USHERED MARGARET INTO THE ROOM WHERE EARL WAS SITTING."

(See page 076.)

ST. NICHOLAS.

VOL. XXXII.

JUNE, 1905.

NO. 8.

THE FIRST VOYAGE OF "THE BROTHERLY-LOVE."

BY ELIZABETH HILL.

"As the time draws near," said Margaret, "I tremble for fear something may happen to prevent our going. It seems to me I could not bear that."

Edith laughed. "What could happen?" she said lightly. And then, checked by Margaret's serious look, she exclaimed, half in irritation, half in raillery: "Dear me, Cassandra, you *are* so solemn! What could happen?"

"Nothing will, I hope," replied Margaret, in her turn; "only, my anticipations are so delightful they seem too good to be true."

"Mother had a letter from Uncle Stevie this morning," said Edith. "He says we must prepare to sail by the 1st of October, for *The Brotherly-Love* is now almost fitted for sea and will soon take on her cargo. Oh, to think of it, Margaret!—in five weeks we shall be sailing!—sailing over the bounding main!" Edith almost skipped on the sidewalk as she hummed the words under her breath, and exclaimed again:

"Well, good-by, Miss Much-afraid; here we must part." Then she turned in at her garden gate and tripped blithely up the walk, while Margaret went slowly and thoughtfully down the sunny street, beneath the yellowing elms.

A year before—she recalled it, as she walked

along,—Edith's uncle, Captain Stephen Yates, had said, one evening, when she was taking tea at Edith's, "Girls, how would you like to go out to Buenos Aires with me next year?"

"Oh, Uncle Stevie!" cried Edith. "Do you mean it?"

"I do," replied Captain Yates. "Phillips Brothers are going to build a four-master to carry lumber to South America. I am half-owner, and shall have command of her. She will be launched sometime next summer or fall, and will be called *The Brotherly Love*. James Phillips is going out to Buenos Aires to take John's place there, and his two sisters—those charming spinsters, Miss Abigail and Miss Cynthia—are going with him. Now, if you would like to make the trip I will take you. We can accommodate four ladies as well as two. That is our limit, however. They are nice "girls"; and I know a number of people in Buenos Aires, so I think you would have a good time."

"How about school?" said Edith's mother.

"The time would not be lost," Captain Yates replied; "they could be learning things that their books would not teach them. Besides, they could study on the voyage. And in the meanwhile they can work hard at their lessons. I suppose Edith leads her class?"

"Dear me, no!" said Edith, laughing, as she saw the twinkle in her uncle's eyes.

"Margaret does n't, either," she added; "but she comes pretty near it. She would lead if it were not for Marie Bowen. But don't tempt her, Uncle Stevie; anybody that should try to get ahead of Marie Bowen would probably need a sea voyage before long."

That was a year before; and in the meantime Margaret had led her class, for Marie Bowen suddenly dropped out of the ranks.

In December Marie took a severe cold, which resulted in pneumonia, and she did not recover her health. During the winter Margaret and Edith were very attentive to her (although she was not a particularly intimate friend of theirs); but there were so many things to take up their attention that gradually, and unconsciously, the days and weeks passed, until now they had not seen her for two months. Margaret studied a good deal, and helped her mother about the housework, and Edith—out of school hours—was taken up with social gaieties. Then, when vacation began, they went into the country; and since their return they had been busy sewing for the voyage.

And all the year this enchanting prospect had occupied their minds. They kept it to themselves, because—as Margaret said—it would "commonize" it to have everybody knowing it and talking it over for months beforehand; but alone together they talked of little else. They read everything they could find relating to the seas they should cross and the places and people they should visit; they wondered what the Phillips "girls" were like, and made guesses about them; they wondered, also, if Mr. Phillips were older than Captain Yates, who (so Edith said) was "just the right age—old enough to know a lot, and not too old to want lots of fun—more like a cousin than an uncle"; they wondered if they should be seasick, and if they should know the Gulf Stream when they got into it, and if they should see any wrecks or derelicts, and ever so many other things; they wore their old clothes, that they might have new ones when the time came; they saved most of their spending-money, that they might buy curiosities to fetch home. And Margaret had hard work not to

let her day-dreams interfere with her daily duties; the sea never quite ebbed from her thoughts.

Now, at the beginning of school, they were going to tell their teachers and fellow-students, and bid them good-by for six months at least. Margaret felt regretful to lose her high place in the class; and that afternoon, as she reflected upon it, she remembered Marie Bowen, and, for the first time, had a vivid, realizing sense of what Marie's loss must have been.

She had thought that she felt sympathy for Marie before, but it was not this pang of true understanding. "How much harder it must have been for her!" she mused. "Her rank was perfect right along, and she counted on winning the scholarship. It was not mere honor she was after; she needs it, for they are poor. And she had not only to lose it, but to be sick also. I wonder if she is going back to school this term. I am ashamed of myself; I have not been near her since—oh, dear! it was in strawberry-time!—I went down to carry her some of Aunt Marty's berries. I am a mean, selfish thing! I don't deserve this happiness! I will go see her at once!"

It was a long walk, and the sun was low when Margaret reached the narrow, densely shaded street and the little house where Marie lived. Mrs. Bowen came to the door, and Margaret felt a sudden discomposure at the look of her face—it was so worn and wearied.

"How is Marie?" asked Margaret, anxious and self-reproachful.

"She does not improve, I'm sorry to say," Mrs. Bowen answered, in a tired, troubled voice. Then she ushered Margaret into the room where Marie was sitting.

It was dim, because of the heavy foliage in the street. The floor was strewn with white work. A sewing-machine stood at one window, and Marie sat close to the other, languidly pulling out bastings. Her face was emaciated, wan, and mournful. Margaret was shocked. Was this Marie Bowen, who had been so high-spirited?—who, even last winter and spring, when she was suffering, was always hopefully bright?

Marie came forward to greet her caller, trying to smile a welcome. "I am so glad to see

you," she said; but her cordiality had no sparkle.

"Marie," said Margaret, "when I was here last you were better, and I hoped the summer would do you good." She did not dare say more, for it was plain that Marie was worse.

"Yes," said Marie; "I hoped so, myself."

There was a slight pause. Then Margaret resumed: "Your cough—is n't it better?"

"Yes, thank you; I don't cough much," was Marie's brief answer. She sat down weakly, and leaned back in her chair, looking very white.

"What does the doctor say?" Margaret asked of Mrs. Bowen. "Does n't he think—How long will it be before he can cure her?"

There was silence for a moment—a silence fraught with evident emotion. Margaret felt that she had been tactless to ask such a question before Marie. She saw that Marie turned her face to the window; and she noted the bitterness in Mrs. Bowen's voice, as she answered slowly and unsteadily: "He says that only a change of air could help her."

"Where does he advise her to go?" asked Margaret, with an effort.

"He recommends a sea voyage," Mrs. Bowen replied, and there was an under-note of sarcasm in her now calm voice.

Margaret Vaughan was often thoughtless and sometimes selfish because she was young, not because she had a selfish or unthinking nature; but when she did think she felt from the bottom of her heart. There came to her now a vision of Marie at school a year before—the animated, ambitious countenance, the confident manner, the vibrant voice. And then came a memory of the face that had always welcomed Edith and herself the winter before—pale and wasted, but bright with desire and hope; and her heart sank as she contrasted those lifeful looks with the piteous eyes that were now shunning her own. There came to her, in a flash, the cruel meaning of it all: the months of pain, sorrow, and patient struggle; the disappointment; the despair. She looked at the machine and the heaped-up work, and at Mrs. Bowen's thin, sad face; and she thought—what she had once or twice half thought before—of the ever-increasing doctor's

bill. Marie had had the doctor every day for several months; and they were poor, to begin with. She heard again that bitter tone—"He recommends a sea voyage." And then it came surging over her, like a great, smothering wave,—this was what her strange foreboding meant,—she could not have that happy voyage, for Marie Bowen must go in her stead! *It would save Marie's life!*

Margaret scarcely knew what words she spoke, excepting that she tried to be sympathetic; or what Mrs. Bowen and Marie replied, excepting that they thanked her. Her dismay almost overcame her self-possession. "How can I give it up?" her heart was crying. But in her mind there was no question. As soon as she could politely say good-by she did so, promising to call again in a day or two, and she hastened home to take counsel with her mother.

"But, Margaret," said Mrs. Vaughan, "you are an invited guest; I am not sure that it is becoming for you to take things into your own hands like this."

"I am not taking things into my own hands," replied Margaret; "I'm only going to tell Edith, and she will tell her uncle, and he will invite Marie."

"It is you whom Edith and Captain Yates have invited," said her mother.

"Of course," Margaret assented; "Edith—and Captain Yates, too, since he does not know Marie—would prefer to have me go; but this is n't a question of preference, mother, it is a matter of necessity."

"Your Aunt Marty would take her out to—" Mrs. Vaughan began.

"We ought to have thought of that this summer," said Margaret, impatiently. "If Edith and I—or any of the girls—had shared our vacation visits with her, it might have done her good; but it is too late now for country air to help her."

"Well," said Mrs. Vaughan, "let us have supper, and then we will go over to Edith's and see what she and her mother say."

So Margaret went with some misgivings, although she did not really believe that Edith would object. She told her story earnestly, and waited for a response; but Edith sat silent. "Edith!" said Margaret, imploringly.

For yet a moment Edith did not speak. But at length she said, in an aggrieved way:

"I am very, very sorry for Marie, and of course I want to do something for her. But you talk as if you thought we were to blame for her illness. I don't see why. We are not her only classmates, and we have never been so intimate with her as some others have. Of course we did n't think it was our place to ask her to go with us in vacation."

"As a matter of fact, my dear, we did n't think anything about it," said Margaret.

"Besides," Edith went on, "there 's Uncle Stevie. If Marie is to go, she must be asked at once, that she may have time to get ready. How can we take so much upon ourselves?"

"I feel sure—" Margaret began eagerly, and then stopped, colored, and looked confused.

"Oh, you do, do you?" rejoined Edith, with a gleam of humor in her eyes. "Well, I don't. Uncle will have decided objections—"

"Edith!" exclaimed her mother. "You know better! He will be disappointed, but he will think that Margaret is right."

Margaret turned eagerly to Mrs. Yates. "You see," she said, "the necessity for it?"

"Yes, I do," answered Mrs. Yates, warmly. "And so does Edith; this is only her way of expressing her disappointment. Edith—"

"Well, I don't care!" Edith retorted. "Margaret's conscience always works like a thunder-clap out of a clear sky."

"How ought conscience to work?" asked Margaret, drawing a breath of relief.

"Gradually," answered Edith. "That 's what conscience is for—to have a 'wrestle' with. My good impulses are like vaccination—I have a terrible time before they take."

After a pause she continued:

"Of course I shall do it. I always do what you want me to. You just wind me round your finger. I will go down to Marie's to-morrow and ask her. If she thinks it strange that you are not going, I will say that you were invited, but that it is impossible for you to go—which is quite true according to your reasoning. And when Uncle Stevie comes I will face him dauntlessly. And I will take good care of her, and hide my woe behind a mask of cheerfulness. But I should rather not go at all than

go without you—for all you are so difficult to get along with."

"Edith!" her mother exclaimed.

"I don't care!" said Edith again. "I feel as if I were going to cry. And I am. So there now!"

"So am I," said Margaret, in a heartfelt tone. "I don't see how I can ever bear it. But, of course, we ought to be thankful that we have found out in time. I could never have forgiven myself if—it had been too late."

Next day Mrs. Yates and Edith called at Mrs. Vaughan's.

"It 's all settled," said Edith. "Marie is going. I wish you could have seen her mother's face when mother gave the invitation. Marie did n't seem to care, though she was polite enough. But I waxed eloquent over the sunsets on the sea, the tropical moonlights and stars and balmy airs and things, and the delights of Buenos Aires, and what a duck Uncle Stevie is, until she warmed up to it. But her mother looked as if—as if she were going herself."

"I think she needs it almost as much as Marie," said Mrs. Yates. "And I wish she could go, too, on Marie's account. Marie needs a better nurse than my well-meaning but rather inexperienced daughter."

"Mrs. Bowen was so relieved," she continued, "that she let me see a little into their troubles. Did you know that she lost her husband and only son five years ago?"

"No," said Margaret; "you know we have known Marie only two years—since we began going to the high school."

"She has supported herself by machine-work—a very poor livelihood. Her only hope is in Marie. She looks as if she were becoming bitter and hard over their troubles."

"I don't wonder!" Margaret exclaimed vehemently. "Such a depressing place, 'way in that dead-and-buried street; and that dreary pile of work, day after day, for years; and nobody caring; and fresh trouble forever washing up—layer upon layer! It 's enough to make people bitter and hard!"

"Well, she won't now," said Edith; "she will begin to hope again—thanks to you, dear."

In the days that followed, Margaret often thought of Edith's "vaccination" remark, for she had her "terrible time" getting used to relinquishment. She studied with all her might;

gleam of sun-bright sails, and almost hearing the winds and waters, when a sudden peal of the bell startled her, and in rushed Edith, followed more sedately by Captain Yates.



"DID YOU THINK WE COULD SAY WITHOUT YOU?" HE ASKED, SMILING. (SEE PAGE 689)

and she grew even thin and more than usually sober and quiet. The evening before the girls were to start for Portland to join Captain Yates and *The Brotherly-Love*, she was sitting with her history, trying to fix her mind upon the lesson, but seeing, instead of words, the

"Margaret," cried Edith, seizing the book and twirling it across the table, "go and pack at once! You are going, too!"

"I?" said Margaret, in bewilderment, turning pale. She rose as if in a daze, and mechanically offered her hand to Captain Yates.

He took it, and held out his left hand for her other one. "Did you think we could sail without you?" he asked, smiling.

"But you said," Margaret stammered, flushing and trembling with surprise and joy—"you said that your limit was four."

"I know; I thought so then," he replied. "*The Brotherly-Love* is not fitted up for passengers, and we were prepared to accommodate only four ladies; but we shall rig up an extra

cabin and stow you all away somehow." And he laughed.

"And Mrs. Bowen is going too," said Edith. "We have just come from there. And Marie has had calls from lots of the girls. They have brought her reading enough to last a lifetime. And we are going to start at five o'clock in the morning; so go upstairs and pack now, quick. Come, Uncle Stevie, you and Margaret can have it out later on."

HIS CADDY.

BY BESS GOE WILLIS.



How do you like my caddy?

He 's the nicest dog I know.

The sticks belong to daddy.

"Fore! Fore!" Now watch it go!

RIDGE'S TRIPLE PLAY

BY MARJORIE ALLISON.

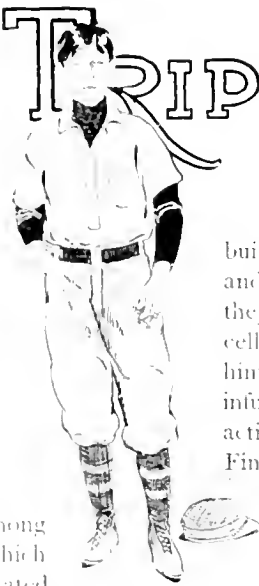

THE road leading to the ball-ground was thronged on that Saturday afternoon, for the High School and the Preparatory School of Sagamore were to play the deciding game of the series for the school championship, each having won two of the five games that constituted the year's contest.

These two schools ranked high among the institutions of the country at which boys prepared for college. The elevated ground on which the town stood provided superb ball-grounds, for which nature had done so much that art could make little improvement. From the home plate to center-field the smooth turf lay as even as the top of a table, and the diamond was without a flaw. Deceptive bounds of swift grounders and resulting black eyes or bruised noses were unknown on the grounds of the Sagamore schools' base-ball clubs.

Long before the hour set for the game—three o'clock—the shady places under the trees, where benches had been placed, were packed with spectators; for this deciding game was one of the features of the town, and all the residents were deeply interested in whatever concerned the two schools. Besides, there were many graduates of the schools and visitors at the hotels, and, as many of them were friends or relatives of the school-boys, they were very enthusiastic attendants.

There was a predominance of red ribbons as it happened, for red was the Preparatory's color. The nine of that school was the favorite, and one reason was that, though the younger and the weaker team, they had held their own so well against the brawny giants who composed the High School nine.

By two o'clock most of the "Preps" were on the ground, and by half-past all were there, and practising furiously. They were slim, slightly

built lads, but coached by their captain and first-baseman—Jack "Scoop," they called him—to a remarkable excellence in throwing and running. Jack himself was a phenomenon, and had infused a large amount of his own fire, activity, and accuracy into his team. Fine fielders, all of them, they made up in this respect for their weakness at the bat.

At stealing bases they were most expert thieves. Let one of them but reach first base on a hit or an error, and second was easy prey for him. The "modern catapult" that officiated in the "box" for the High School, and the catcher of the same nine, knew this thoroughly, and many were the schemes concocted to catch a runner. But generally on the first ball pitched he was off for second, and in nine cases out of ten gained it by a desperate slide, while the verdict "Safe!" from the umpire, and a storm of cheers from the crowd, gladdened his heart as he dusted his padded trousers and smiled kindly on the discomfited second-baseman.

Shortly before three o'clock, the High School reached the grounds, looking handsome and strong in the brown uniforms; and their brown-ribboned friends greeted them warmly and cast pitying glances on the Preps in their gray suits with red trimmings. For ten minutes the "Highs" practised, and then Captain "Scoop" and the catcher of the High School nine tossed up, and the Prep's nine was sent to the bat, having lost the first point in the eventful day's proceedings.

The game progressed rapidly, with few errors, few runs, and many close decisions, none of which, however, was disputed. The umpire was the left-fielder of a noted college nine, and he excited the awe and admiration of every boy on the field. Ridge was playing second base on the Preparatory nine, and if at the beginning

of the game he was excited and nervous, who can blame him? But as the game went on the important feature of his organization had resumed its normal state, and he played as coolly

ball pass him, he had not, as yet, been able to put a man out at his base; a couple of flies, half a dozen assists to first, and one to home base, constituted his fielding up to that time.



"RIDGE LEAPED WITH HAND OUTSTRETCHED HIGH IN THE AIR"

as if this were the first, instead of the last and deciding, of the championship series.

The Preparatory's catcher was not at his best that day, and three or four bases had been stolen with impunity. All of his throws to the second-baseman had been a little slow or a trifle wild, and although Ridge had not let a

At the bat he had been more fortunate, having made two well-timed "singles" that helped wonderfully; and in the Preps' half of the ninth inning he had driven the ball over the left-fielder's head, bringing in two runs, and reaching third himself. These two runs tied the score. A moment or two later a desperate dash for home resulted in a fumble by the catcher in his excitement. Ridge slid. "Safe!" cried the umpire; and the Preparatory's score stood one ahead. The next man "fanned" out, and the Preps took the field amid an excitement unparalleled in the history of base-ball at Sagamore.

The strain was too much for the Preparatory's pitcher. The first High to the bat made first base on a scorching grounder past third; a moment later he was forced to take second by a base on balls. It was too bad! With the most daring runner of the High School nine on first, and their heaviest hitter at the bat, the Preps' chances seemed small and the outlook gloomy.

"Watch for home, boys!" cried Captain Jack, and the Prep played close. Ridge got inside the base-line some distance from second, while the short-stop watched the runner.

A ball or two had been pitched, when crack! went the heavy bat against the ball, as the batter swung it with all his might, and, almost without knowing it, Ridge leaped with hand outstretched high in the air, and as the swift liner flew over his head, his fingers clutched and held the ball. The man on first, thinking the hit

safe, had taken a long lead and was near second when Ridge caught the ball, while the man on second, with equal confidence, had started in a very leisurely way for third. Ridge touched the one nearest as he passed him and with the same impulse started to second. The High School boy had turned, but it was too late; Ridge reached the bag, and "Out! Out!! Out!!!" came in such quick succession from the umpire that the second and third words sounded like quick echoes. The side was out; the game was won for the Preps!

Ridge told the captain after the game that although he had played many games of baseball, and might play many more, he had never felt, and never again would feel, the glow of exultation and pride he experienced when the umpire took his hand and said:

"My boy, I want to tell you that was the neatest play I ever saw on a ball field!"

HOW TO STUDY PICTURES.

BY CHARLES H. CLEGG.

A text-book for the girls and boys who read "St. Nicholas."

EIGHTH PAPER.

COMPARING SIR JOSHUA REYNOLDS WITH GAINSBOROUGH.

SIR JOSHUA REYNOLDS (BORN 1723, DIED 1792); THOMAS GAINSBOROUGH (BORN 1727, DIED 1788).

IN the same year, 1784, that Sir Joshua Reynolds's picture, "Mrs. Siddons as the Tragic Muse," was exhibited at the Royal Academy, the famous actress sat for her portrait to his rival, Gainsborough. Sarah Siddons was then in her twenty-ninth year, in the prime of her beauty, and in the first flush of that popularity which was to make her the queen of the English stage for thirty years.

We can compare two aspects of her personality in these pictures. Sir Joshua exhibits her in an attitude of rapt contemplation, as if gaz-

ing into the world of the imagination and listening for the voice of inspiration; dressed in a costume which at the end of the eighteenth century passed for "classical." In Gainsborough's picture she appears as she may have looked when Fanny Burney met her, in 1782, while paying an afternoon call at a friend's house. Mrs. Siddons had just become famous. Miss Burney makes this entry in her diary: "We found Mrs. Siddons, the actress, there. She is a woman of excellent character, very calm, modest, quiet, and unaffected. She has a fine countenance, and her eyes look both intelligent and soft."

In this picture, her hair is frizzled and powdered after the fashion of the time, and sur-

mounted by a large, black-feathered hat; she wears a blue-and-gray-striped silk dress, with a buff shawl hanging from her arm, and holds a

and that the blue, gray, or green colors should be kept almost entirely out of these masses and "be used only to support and set off these warm colors; and for this purpose a small proportion of cold colors will be sufficient. Let this conduct be reversed," he added, "let the light be cold and the surrounding colors warm, as we often see in the work of the Roman and Florentine painters, and it will be out of the power of art, even in the hands of Rubens or Titian, to make a picture splendid and harmonious."

It is said that Gainsborough took up the challenge and produced the "Mrs. Siddons" portrait; though others assert that it was in another famous portrait, "The Blue Boy," that he did this. Whether or not it be true that he deliberately painted these pictures to refute his rival's theory, matters very little beside the fact that they do refute it. For one of the chief charms of Gainsborough's work is the delicacy of his color-harmonies, in which he was entirely original. But this story brings out very sharply the difference between these two artists: Reynolds regu-



"MRS. SIDDONS AS THE TRAGIC MUSE," BY REYNOLDS. (PHOTOGRAPH BY VALENTINE, LONDON.)

lating his art and life on safe and ordinary principles. Gainsborough following always the beckoning of a dreamy, poetic temperament; the one a man of the world, the other simply an artist.

Sir Joshua, in the eighth of the discourses which, as president of the Royal Academy, he delivered to the students in 1778, laid down the principle that the chief masses of light in a picture should always be of warm, mellow color,

Sir Joshua was born at Plympton, four miles from Plymouth, in Devonshire, in 1723. His

father, rector of the grammar-school, early trained him in classical studies, intending his son to be an apothecary; but he displayed

the Mediterranean station, invited the young painter to accompany him in his ship, the *Centurion*. Thus he was able to visit Rome,



PICTURE OF THE AUTHOR'S MOTHER.

such an inclination for drawing, diligently copying the prints which fell in his way, that the father yielded and sent him to London as a student of art. After two years he returned to Devonshire and established himself as a portrait-painter in Plymouth, where he was taken up by Commodore Keppel, who, being appointed to

spending two years there in very close study, especially of the works of Raphael and Michelangelo. It was while painting in the corridors of the Vatican that he contracted a cold which brought on the deathness that afflicted him during the rest of his life. Leaving Rome, he visited Parma, where he fell under Correggio's

influence, then Florence and Venice, in the latter city studying the works of the great colorists. On his way home he stopped in Paris, making acquaintance with the work of Rubens. Arrived in London, he settled in St. Martin's Lane, and painted a portrait of his patron, Commodore (then Lord) Keppel, which laid the foundation of his fortunes. Later he established himself in Leicester Square, where his house, No. 47, may still be seen.

Van Dyck had been dead a hundred years. Though his memory was a great tradition in England, no Englishman had succeeded to his fame, and yet portraiture was the trend of painting that chiefly interested the English. Reynolds, coming back from his travels with well-considered rules which he would follow if it were possible for him to paint historical or ideal subjects, immediately adapted himself to circumstances and applied these rules to portrait-painting. Every portrait should be a picture as well as a rendering of the features of the original. He had learned how Michelangelo made the attitudes and gestures of his figures so full of expression; what triumphs of light and shade were produced by Correggio; the dignity and sumptuousness of Venetian coloring, the decorative splendor of Rubens's pictures, and the exquisite sentiment of Raphael's women and children and the dignity that this artist gave to the heads of men. He had learned all this and much more, and set himself to combine as much of these different qualities in his portraits as he could. "No one," said James Northcote, a pupil of Reynolds who wrote his life, "ever appropriated the ideas of others to his own purpose with more skill than Sir Joshua. The opinion he has given of Raphael may, with equal justice, be applied to himself: 'His materials were generally borrowed, but the noble structure was his own.'"

In this Siddons portrait Reynolds, intimate friend of the great actor Garrick and of the brilliant orator Burke, tried to represent the mighty impressiveness, the emotional grandeur and intellectual splendor, of the nobly spoken world. The actress, with her right arm extended, looks as if she may spring from her seat and impetuously give out of herself what she feels. Throughout all Reynolds's work there is a

strong inclination toward the dramatic representation; even the children—and no one ever painted sweeter children than he—unconsciously played some little part. Moreover, Reynolds lived in the grand world, painted all the great and fashionable people of his time, and sought to apply to portraiture the principles of the "grand style" of painting.

Look back to Gainsborough's "Mrs. Siddons," and see how free from anything dramatic or "grand" it is; how simple and straightforward, true and sure in the drawing. On the other hand, quite as noticeable is the delicacy of the picture: its refinement of expression and the delicate rendering of the face and hair; while we have already alluded to the choice and original beauty of the scheme of color-harmony. Altogether there is a rare quality of distinction in this picture, which we shall not find in the Reynolds, for all its grandeur. It is also a much finer kind of distinction than appears in Van Dyck's pictures; and I think we may discover why.

This quality of distinction in a picture is not so much a reproduction of something in the subject as of something in the artist, else we might expect to find it as evident in Reynolds's picture as in Gainsborough's. No; you may find this quality also in a landscape. It is an expression of the mind and imagination of the artist, even as the touch of a musician is an interpretation not only of the music, but of the way in which the music affects him — an expression of himself, in fact.

Gainsborough, while painting portraits for a living, painted landscapes for his own pleasure, and lived at Hampstead during the summer that he might be constantly in fellowship with nature. It was this love of nature and of simple things, and the faculty of seeing beauty in them, that gave such a choice distinction to his work, because it was the expression of his own simple, lovable personality. He had beauty in himself, and all his life it fed on simple delights — the joys of nature, of domestic happiness, of music, and of his own art.

He was born in the little town of Sudbury, on the river Stour, in the beautiful county of Suffolk. As a boy he loved to ramble in the country, sketching; and showed so much inclination for

it, and so little for any other kind of study, that when he was fifteen he was sent to London and placed under the care of a silversmith, who procured him admission to the St. Martin's Lane Academy. Here he worked for three years studying painting. Gainsborough's eighteenth year was an eventful one. He hired three rooms in Hatton Gardens and set up as a painter on his own account. Meeting with little encouragement, he returned to Sudbury; there he fell a victim to the charms of a young lady of seventeen, Miss Margaret Burr, who had an annuity of \$1000, married her, and established himself in the country town of Ipswich. Here he worked on happily and quietly for fifteen years, continually studying in the open air and executing such small commissions for portraits as came to him, until he had succeeded in discovering for himself a manner of painting suited to his needs, and had developed an extraordinary skill.

In 1760 he moved to Bath, at that time the most fashionable city outside of London. The gay world of that time congregated there to drink the waters.

Gainsborough's success was immediate, but with increasing wealth there was no alteration in his simple method of living. He worked four or five hours a day, and devoted the rest of his time to the society of his wife and a few friends who were musical. For music now became a passion of his life, so that it was said he painted for business and played for pleasure, constantly mastering some fresh instrument.

So passed fourteen years, when, in 1774, Gainsborough moved to London, was commissioned by George III to paint a portrait of himself and the queen, and became the rival of Reynolds. He died in 1788, having contracted a chill while attending the trial of Warren Hastings, and was buried at his own request in Kew Churchyard. On his death-bed he sent for Reynolds. There had been misunderstand-

ing and estrangement between the two. It was now forgotten. Reynolds caught his last dying words, "We are all going to heaven, and Van Dyck is of the party." Reynolds also acted as one of the pall-bearers at the funeral, and subsequently pronounced a eulogy upon him.

Sir Joshua himself survived Gainsborough only four years. He was buried with much pomp in St. Paul's Cathedral.

The contrast between these two artists is almost the difference between art and nature. Reynolds was learned in what other painters had done, and had reduced his own art to a system. Gainsborough found out almost everything for himself; never lost the simple, natural way of looking at things and people; and painted not according to rule, but at the dictates of what he felt. Reynolds planned out his effects, Gainsborough painted on the spur of the impression which the subject aroused. Reynolds's art was based on safe general principles; Gainsborough's was the fresh and spontaneous expression of his temperament—depending, that is to say, on feeling rather than on calculation. His temperament, or habit of mind, was dreamy and poetic, gentle and retiring, including a small range of experience. Reynolds, on the other hand, was a man of the world and of business capacity; intimate with Samuel Johnson, Oliver Goldsmith, and other celebrities of the day; a man of knowledge and clever conversational power, whose pictures by their variety prove his versatility. Consequently, when the Royal Academy was established in 1768, he was elected president by acclamation and was knighted by George III, an honor that has ever since been bestowed on the holder of this office.

These two men were at the head of the group of portrait-painters who, in the latter part of the eighteenth century and in the early years of the succeeding one, added luster to the new growth of art in England.

QUEEN ZIXI OF IX.

Copyright, 1905, by I. FRANK BAUM

BY I. FRANK BAUM.

Author of "The Wizard of Oz."

CHAPTER XV.

THE THEFT OF THE MAGIC CLOAK.

WHEN the soldiers of Queen Zixi ran away, they fled in so many different directions that the bewildered queen could not keep track of them. Her horse, taking fright, dashed up the mountain-side and tossed Zixi into a lilac-bush, after which he ran off and left her.

One would think such a chain of misfortunes could not fail to daunt the bravest. But Zixi had lived too many years to allow such trifles as defeat and flight to ruin her nerves; so she calmly disentangled herself from the lilac-bush and looked around to see where she was.

It was very quiet and peaceful on this part of the mountain-side. Her glittering army had disappeared to the last man.

In the far distance she could see the spires and turreted palaces of the city of Nole, and behind her was a thick grove of lilac-trees bearing flowers in full bloom.

This lilac-grove gave Zixi an idea. She pushed aside some of the branches and entered the cool, shadowy avenues between the trees.

The air was heavy with the scent of the violet flowers, and tiny humming-birds were darting here and there to thrust their long bills into the blossoms and draw out the honey for food. Butterflies there were, too, and a few chipmunks perched high among the branches. But Zixi walked on through the trees in deep thought, and presently she had laid new plans.

For since the magic cloak was so hard to get she wanted it more than ever.

By and by she gathered some bits of the lilac-bark, and dug some roots from the ground. Next she caught six spotted butterflies, from the wings of which she brushed off all the round, purple spots. Then she wandered on until she came upon a little spring of water bubbling

from the ground, and filling a cup-shaped leaf of the tatti-plant from the spring, she mixed her bark and roots and butterfly-spots in the liquid and boiled it carefully over a fire of twigs; for tatti-leaves will not burn so long as there is water inside them.

When her magical compound was ready, Zixi muttered an incantation and drank it in a single draught.

A few moments later the witch-queen had disappeared, and in her place stood the likeness of a pretty young girl dressed in a simple white gown with pink ribbons at the shoulders and a pink sash around her waist. Her light-brown hair was gathered into two long braids that hung down her back, and she had two big blue eyes that looked very innocent and sweet. Besides these changes, both the nose and the mouth of the girl differed in shape from those of Zixi; so that no one would have seen the slightest resemblance between the two people, or between Miss Trust and the girl who stood in the lilac-grove.

The transformed witch-queen gave a sweet, rippling laugh, and glanced at her reflection in the still waters of the spring. And then the girlish face frowned, for the image glaring up at her was that of a wrinkled, toothless old hag.

"I really must have that cloak," sighed the girl; and then she turned and walked out of the lilac-grove and down the mountain-side toward the city of Nole.

The Princess Fluff was playing tennis with her maids in a courtyard of the royal palace, when Jikki came to say that a girl wished to speak with her Highness.

"Send her here," said Fluff.

So the witch-queen came to her, in the guise of the fair young girl; and bowing in a humble manner before the princess, she said: "Please, your Highness, may I be one of your maids?"

"Why, I have eight already!" answered Fluff, laughing.

"But my father and mother are both dead; and I have come all the way from my castle to beg you to let me wait upon you," said the girl, looking at the little princess with a pleading expression in her blue eyes.

"Who are you?" asked Fluff.

"I am daughter of the Lord Hurrydole, and my name is Adlena," replied the girl, which was not altogether a falsehood, because one of her ancestors had borne the name Hurrydole, and Adlena was one of her own names.

"Then, Adlena," said Fluff, brightly, "you shall certainly be one of my maids; for there is plenty of room in the palace, and the more girls I have around me the happier I shall be."

So Queen Zixi, under the name of Adlena, became an inmate of the king's palace; and it was not many days before she learned where the magic cloak was kept. For the princess gave her a key to a drawer and told her to get from it a blue silk scarf she wished to wear, and directly under the scarf lay the fairy garment.

Adlena would have seized it at that moment had she dared; but Fluff was in the same room, so she only said: "Please, princess, may I look at that pretty cloak?"

"Of course," answered Fluff; "but handle it carefully, for it was given me by the fairies."

So Adlena unfolded the cloak and looked at it very carefully, noting exactly the manner in which it was woven. Then she folded it again, arranged it in the drawer, and turned the key, which the princess immediately attached to a chain which she always wore around her neck.

That night, when the witch-queen was safely locked in her own room and could not be disturbed, she called about her a great many of those invisible imps that serve the most skil-

ful witches, commanding them to weave for her a cloak in the exact likeness of the one given Princess Fluff by the fairies.

Of course the imps had never seen the magic cloak; but Zixi described it to them accurately, and before morning they had woven a garment so closely resembling the original that the imitation was likely to deceive any one.

Only one thing was missing, and that was the golden thread woven by Queen Lulea herself, and which gave the cloak its magic powers.

Of course the imps of Zixi could not get this golden thread, nor could they give any magical properties to the garment they had made at the witch's command; but they managed to give



"WHICH IS MINE?" SHE FINALLY ASKED, IN A STARTLED VOICE."
(SEE NEXT PAGE.)

the cloak all the brilliant colors of the original, and Zixi was quite satisfied.

The next day Adlena wore this cloak while she walked in the garden. Very soon Princess

Fluff saw her and ran after the girl, crying indignantly: "See here! What do you mean by wearing my cloak? Take it off instantly!"

"It is n't your cloak. It is one of my own," replied the girl, calmly.

"Nonsense! There can't be two such cloaks in the world," retorted Fluff.

"But there are," persisted Adlena. "How could I get the one in your drawer when the key is around your own neck?"

"I'm sure I don't know," admitted the princess, beginning to be puzzled. "But come with me into my rooms. If my fairy cloak is indeed in the drawer, then I will believe you."

So they went to the drawer, and of course found the magic cloak, as the cunning Zixi had planned. Fluff pulled it out and held the two up together to compare them; and, sure enough, they seemed to be exactly alike.

"I think yours is a little the longer," said Adlena, and threw it over the shoulders of the princess. "No, I think mine is the longer," she continued; and removing the magic cloak, put her own upon Fluff. They seemed to be about the same length, but Adlena kept putting first one and then the other upon the princess, until they were completely mixed, and the child could not have told one from the other.

"Which is mine?" she finally asked, in a startled voice.

"This, of course," answered Adlena, folding up the imitation cloak which the imps had made, and putting it away in the drawer.

Fluff never suspected the trick, so Zixi carried away the magic cloak she had thus cleverly stolen; and she was so delighted with the success of her stratagem that she could have screamed aloud for pure joy.

As soon as she was alone and unobserved, the witch-queen slipped out of the palace, and, carrying the magic cloak in a bundle under her arm, ran down the streets of Nole and out



"BECAUSE I CANNOT CLIMB A TREE, ANSWERED THE ALLIGATOR."

through the gate in the wall and away toward the mountain where the lilac-grove lay.

"At last!" she kept saying to herself. "At last I shall see my own beautiful reflection in a mirror, instead of that horrid old hag!"

When she was safe in the grove she succeeded, by means of her witchcraft, in trans-



"SHE THREW OFF THE CLOAK AND RAN TO THE CRYSTAL SPRING."

forming the girl Adlena back into the beautiful woman known throughout the kingdom of Ix as Queen Zixi. And then she lost no time in throwing the magic cloak over her shoulders.

"I wish," she cried in a loud voice, "that my reflection in every mirror will hereafter show the same face and form as that in which I appear to exist in the sight of all mortals!"

Then she threw off the cloak and ran to the crystal spring, saying: "Now, indeed, I shall at last see the lovely Queen Zixi!"

But as she bent over the spring, she gave a sudden shriek of disappointed rage; for glaring up at her from the glassy surface of the water was the same fearful hag she had always seen as the reflection of her likeness!

The magic cloak would grant no wish to a person who had stolen it.

Zixi, more wretched than she had ever been before in her life, threw herself down upon her face in the lilac-grove and wept for more than an hour, which is an exceedingly long time for tears to run from one's eyes. And when she finally arose, two tiny brooks flowed from the spot and wound through the lilac-trees — one to the right and one to the left.

Then, leaving the magic cloak — to possess which she had struggled so hard and sinfully — lying unheeded upon the ground, the disappointed witch-queen walked slowly away, and finally reached the bank of the great river.

Here she saw a rugged old alligator who lay upon the bank, weeping with such bitterness that the sight reminded Zixi of her own recent outburst of sorrow.

"Why do you weep, friend?" she asked, for her experience as a witch had long since taught her the language of the beasts and birds and reptiles.

"Because I cannot climb a tree," answered the alligator.

"But why do you wish to climb a tree?" she questioned, surprised.

"Because I can't," returned the alligator, squeezing two more tears from his eyes.

"But that is very foolish!" exclaimed the witch-queen, scornfully.

"Oh, I don't know," said the alligator. "It does n't strike me that it's much more foolish than the fancies some other people have."

"Perhaps not," replied Zixi, more gently, and walked away in deep thought.

While she followed the river-bank, to find a ferry across, the dusk fell, and presently a gray owl came out of a hollow in a tall tree and sat upon a limb, wailing dismally.

Zixi stopped and looked at the bird.

"Why do you wail so loudly?" she asked.

"Because I cannot swim in the river like a fish," answered the owl, and it screeched so sadly that it made the queen shiver.

"Why do you wish to swim?" she inquired.

"Because I can't," said the owl, and buried its head under its wing with a groan.

"But that is absurd!" cried Zixi, with impatience.

The owl had an ear out, and heard her. So it withdrew its head long enough to retort:

"I don't think it's any more absurd than the longings of some other folks."

"Perhaps you are right," said the queen, and hung her head as she walked on.

By and by she found a ferryman with a boat, and he agreed to row her across the river. In one end of the boat crouched a little girl, the ferryman's daughter, and she sobbed continually, so that the sound of the child's grief finally attracted Zixi's attention.

"Why do you sob?" questioned the queen.

"Because I want to be a man," replied the child, trying to stifle her sobs.

"Why do you want to be a man?" asked Zixi, curiously.

"Because I'm a little girl," was the reply.

This made Zixi angry.

"You're a little fool!" she exclaimed loudly.

"There are other fools in the world," said the child, and renewed her sobs.

Zixi did not reply, but she thought to herself:

"We are all alike — the alligator, the owl, the girl, and the powerful Queen of Ix. We long for what we cannot have, yet desire it not so much because it would benefit us, as because it is beyond our reach. If I call the others fools, I must also call myself a fool for wishing to see the reflection of a beautiful girl in my mirror when I know it is impossible. So hereafter I shall strive to be contented with my lot."

This was a wise resolution, and the witch-queen abided by it for many years. She was

not very bad, this Zixi; for it must be admitted that few have the courage to acknowledge their faults and strive to correct them, as she did.

CHAPTER XVI.

THE PLAIN ABOVE THE CLOUDS.

I HAVE already mentioned how high the mountains were between Noland and the land of IX; but at the north of the city of Nole were mountains much higher—so high, indeed,

other high mountain, rising from the level and capped with a second plain; and then another mountain, and so on; which made them somewhat resemble a pair of stairs. So that the people of Nole, who looked upon the North Mountains with much pride, used to point them out as "The Giant's Stairway," forgetting that no giant was ever big enough to use such an immense flight of stairs.

Many people had climbed the first mountain, and upon the plain at its top flocks of sheep were fed; and two or three people boasted they had climbed the second steep; but beyond that the mountains were all unknown to the dwellers in the valley of Noland. As a matter of fact, no one lived upon them; they were inhabited only by a few small animals and an occasional vulture or eagle which nested in some rugged crag.

But at the top of all was an enormous plain that lay far above the clouds, and here the Roly-Rogues dwelt in great numbers.

I must describe these Roly-Rogues to you, for they were unlike any other people in all the world. Their bodies were as round as a ball—if you can imagine a ball fully four feet in thickness at the middle. And their muscles were as tough and elastic as india-rubber. They had curious, stunted heads and arms, and very short legs; and



F. RICHARDSON

"WHY DO YOU WAIL SO LOUDLY?" SHE ASKED."

that they seemed to pierce the clouds, and it was said the moon often stopped on the highest peak to rest. It was not one single slope up from the lowlands; but first there was a high mountain, with a level plain at the top; and then an-

all these they could withdraw into their ball-like bodies whenever they wished, very much as a turtle withdraws its legs and head into its shell.

The Roly-Rogues lived all by themselves in their country among the clouds, and there were

thousands and thousands of them. They were quarrelsome by nature, but could seldom hurt one another; because, if they fought, they would withdraw their arms and legs and heads

mediately rolled themselves to the edge and watched the luckless Roly-Rogue fly down the mountain, bounce across the plain, and thence speed down the next mountain. By and by he



F. K. R.

"WILL DO IT FOR RESTORED THE QUEEN."

into their bodies, and roll themselves at one another with much fierceness. But when they collided they would bounce apart again, and little harm was done.

In spite of their savage dispositions the Roly-Rogues had as yet done no harm to any one but themselves, as they lived so high above the world that other people knew nothing of their existence. Nor did they themselves know, because of the clouds that floated between, of the valleys which lay below them.

But, as ill luck would have it, a few days after King Bud's army had defeated the army of In, one of the Roly-Rogues, while fighting with another, rolled too near the edge of the plain whereon they dwelt, and bounded down the mountain-side that faced Noland. Wind had scattered the clouds, so his fellows im-

mediately became a dot to their eyes, and then a mere speck; but as the clouds had just rolled away for a few moments the Roly-Rogues could see, by straining their eyes, the city of Nole lying in the valley far below.

It seemed, from that distance, merely a toy city, but they knew it must be a big place to show so far away; and since they had no cities of their own, they became curious to visit the one they had just discovered.

The ruler of the Roly-Rogues, who was more quarrelsome than any of the rest, had a talk with his chief men about visiting the unknown city.

"We can roll down the mountain just as our brother did," he argued.

"But how in the world could we ever get back again?" said one of the chiefs, sticking his head up to look with astonishment at the ruler.



"AT THE WORD OF THEIR RULER, THEY

"We don't want to get back," said the other, excitedly. "Some one has built many houses and palaces at the foot of the mountains, and we can live in those, if they are big enough and if there are enough of them."

"Perhaps the people won't let us," suggested another chief, who was not at all in favor of the expedition.

"We will fight them and destroy them," retorted the ruler, scowling at the chief as if he would make him ashamed of his cowardice.

"Then we must all go together," said a third chief; "for, if only a few go, we may

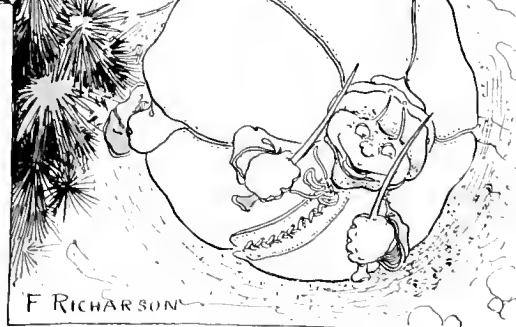

HURLED THEMSELVES DOWN THE MOUNTAIN

find ourselves many times outnumbered and at last be overcome."

"Every Roly-Rogue in the country shall go!"

On the plain grew a grove of big thorn-trees, bearing thorns as long and sharp as swords: so the ruler commanded each of his people to cut two of the thorns, one for each hand, with which to attack whatever foes they might meet when they reached the unknown valley.

Then, on a certain day, all the hundreds and thousands of Roly-Rogues that were in existence assembled upon the edge of their plain, and, at the word of their ruler, hurled themselves

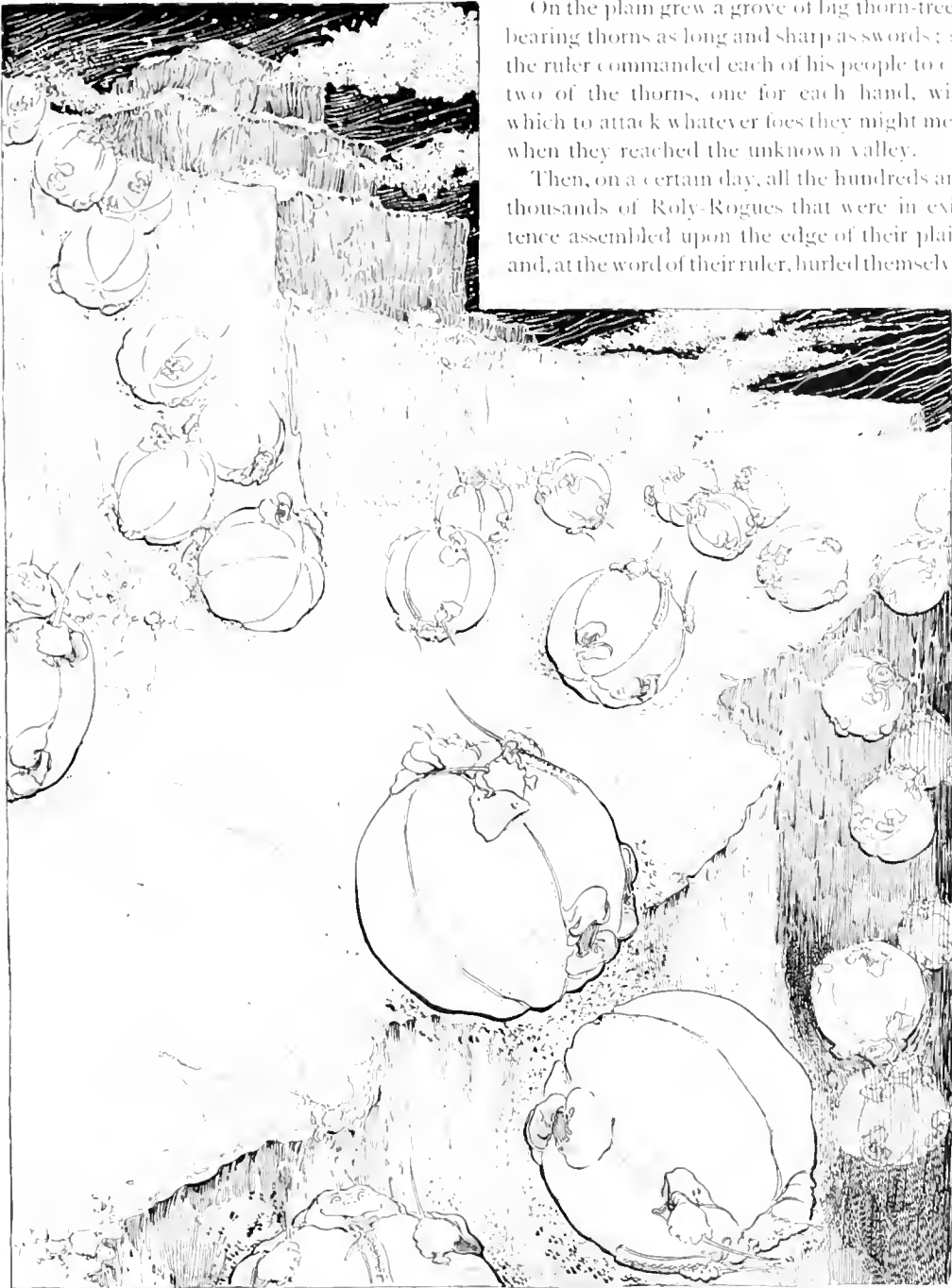

WITH TERRIBLE CRIES AND WENT BOUNDING AWAY TOWARD THE PEACEFUL CITY OF NOLE."

declared the ruler, who brooked no opposition down the mountain with terrible cries and went when once he had made up his mind to a thing, bounding away toward the peaceful city of Nole.

(To be continued.)



"WHY, ONE DAY IN THE COUNTRY
IS WORTH A MONTH IN TOWN!"
CHRISTINA G. ROSSETTI.

FIRST AID TO THE INJURED.

BY DR. EMMA E. WALKER.

II. FRACTURES.

THE boys grew tired of staying in the camp all the time, so Mr. Wilson was always proposing some new trip that he had been thinking up for them. One day he planned an exploring expedition. First they were to cross from the island over to the Ohio side, where they were to take a wagon for a mile or so up to a little town called Belpré, which was named by the French and means "beautiful prairie." There is a little ferry-boat that runs across from Belpré to Parkersburg, which is the opposite town on the West Virginia side. Here the boys were to take the trolley, which winds along the river-bank for about fourteen miles, and finally crosses a bridge over to the Ohio side. This was the "longest way round," which, Jerry said, would be the "most fun." So they engaged Abraham Jennings to row them across the river from the island to the Ohio shore, where he had his farm-wagon waiting to take them up to Belpré.

"Abe," as the boys had nicknamed him, had bright-red hair and a freckled face, and was the jolliest sort of companion. He was well acquainted with all the country round about and its history, and Mr. Wilson was very willing to have him with them. He knew more about the birds and trees than the boys had ever dreamed of before. When Jerry asked him how a paw-paw tasted, he said it always made him think of the apple-custard fruit that he'd read about in "Swiss Family Robinson" and "Masterman Ready." "But," he added, "most people think the pawpaws are more like bananas than anything else, 'cause the inside is soft and yellow and sweet. But the seeds are n't like bananas; they are big and tough and brown. But, boys," he said, "did you ever eat a martynia? That's a queer one for you. They call them mouse-pickles, for they are funny little things, about as big as a small, fat cucumber, with a long, thin, curly tail. And mother makes lovely sweet

pickles of them!" The boys declared they had never heard of such queer things — right in their own country, too. Abe said he'd bring over some of the mouse-pickles to the camp.

Just then they overtook Tom Smith, a boy friend of Abe's, who was also on his way to town, and they offered him a lift. Tom climbed up and said he'd drive the wagon back from the ferry to a barn up on the bank, where it could stay till the boys came back from their trolley-ride. As they were about half-way down the levee, Tom turned round to say something to Abe, when one of the horses stumbled, and in the effort to keep his balance Tom pulled so hard on one of the reins that it snapped and the poor little driver went rolling down to the ground. Abe managed to stop the horses, but not till one of the heavy wheels had rolled over Tom's leg. Mr. Wilson and the boys jumped to the ground and lifted him to one side of the road, laying him gently on some blankets which were taken from the wagon.

The boys ran to the nearest house, where Mr. Wilson told them to ask for a large feather-pillow. They also saw an old, narrow door lying in the barn, and this they brought back for a stretcher. With the boys' help, Mr. Wilson very carefully slid the pillow under the injured leg, and then bound it around with strong cord which Abe always carried in his pocket. They then placed poor Tom on the door, which they lifted, with its burden, into the wagon, that had been turned around ready for driving home. Poor Tom was badly hurt, although he bore his pain very bravely; and the boys knew that their trip was over for that day. Indeed, they had no heart for it at all, for Mr. Wilson told them he thought Tom's leg must be broken. He knew that Tom's father would have no one but his own doctor; and as the doctor had gone some miles into the country that morning, it was not

wise to wait for him by the roadside, so the little party went back to Tom's home. Abe drove very slowly; and as the wagon had fairly easy springs, the drive home was not so painful for the poor fellow as it might have been.

Before starting, Mr. Wilson, who always carried a supply of bandages when out with the boys, took from his pocket some pads of gauze which he wet in the cool river water and put on the injured leg over the part where he feared the bone was broken; for the leg was useless and was very painful, and began to swell and turn black and blue. They changed the bandages several times before reaching Tom's home, as they had a bucket in the wagon which they had filled with river water when they started back. On reaching the house, they carefully carried in the door on which poor Tom was stretched and laid it on a bed to await the family doctor's arrival. They put a pillow under Tom's head, and he declared that he was quite comfortable and felt very little jar as they moved him. The boys were now in no humor for their trip, and so they went back home to their island camp, talking earnestly about the accident. John was especially eager to understand all that Mr. Wilson had done for Tom, and asked why he had n't kept him by the roadside till the doctor came.

"I should have done so," said Mr. Wilson, "if we could have got hold of the doctor within an hour; but as it was to be so long before we could get him, the best thing was to take Tom home, where he could be comfortable."

"Well, guardie," said Jerry, "why did n't you try to set the leg? Could n't you have done it?"

"That is the most important thing of all, I think, for boys to know about a broken bone," said Mr. Wilson; "that is, that they must *let it alone*. You must never try to set a broken bone, for you might injure it so that it would never be right again."

"Well, but, guardie, you tied a pillow round Tom's leg,—that was doing something to it," said John.

"Yes, that was helping it; the pillow kept it as quiet as possible, for every movement of the limb hurts a broken bone. If we had put

poor Tom into the wagon without laying him on Mr. Brown's old door, and without the pillow, he would have been so jolted and shaken up by the time we reached his house that the leg would have been inflamed, and the bone, which I suspect is broken, would have been very hard to set on account of the swelling which would have followed. Some swelling had set in as it was."

"Well, another thing, guardie, that I don't quite understand," said John: "there was n't any blood on Tom's leg. Now last winter, when James fell off the step-ladder and broke his arm, I saw blood all over it."

"Lucky for Tom that there was n't any blood," said Mr. Wilson. "You've struck the nail on the head, for that's what makes the difference between a simple and a compound fracture, that you hear so much about when people break their legs or arms. You will learn all about that when you go to the medical school. When a bone is broken and the flesh is not injured, it is called a simple fracture, and is far less dangerous than the other kind, in which not only the bone is broken but the flesh is injured, sometimes the bone even sticking out, so that you can see it. This is called a compound fracture. Then there are lots of chances for microbes to get in and do their deadly work. The danger from microbes is one thing that makes a compound fracture so serious."

"But," said John, "what would you have done if it had been a sprain and not a broken bone at all?"

"I should have sent you up to Mrs. Brown's kitchen to get a pail of hot water, and I should have put Tom's foot—for we'll pretend that it was his ankle that was sprained—into the water, just as hot as he could bear it. That would have eased the pain and stopped the ankle from swelling so much. As the water cooled off we should have added more hot water, then we should have taken Tom home carefully, though we should n't have needed a barn door. An accident like that would have meant for Tom some days of sitting quiet, with his foot on a pillow on another chair. But I have seen a doctor bind a sprained ankle with strips of surgeon's plaster, which supported it so well

that the boy could walk across the floor at once without injury to the foot."

"It seems to me that we're having good and plenty of accidents this summer," said Jerry.

"Yes, we are having our full share, there is no doubt of that," said Mr. Wilson; "but, after all, I don't think it's very unusual with a party of such active boys. Do you?"



WHO IS IT?

BY WILL P. SNYDER.

WHO is it is so tired
 At the closing of the day?
 Who is it washed and ironed
 And put dolly's things away?
 Who is it is so sleepy
 When she climbs on papa's knee?—
 "I do not know e'zactly,
 But I dess 'at 's me."

Who is it is so sorry
 That she broke the china vase?
 Who is it teased the kitty
 And got scratches on her face?
 Who promised just this morning
 A much better child to be?—
 "I do not know e'zactly,
 But I dess 'at 's me."

Who is it lies on mama's lounge
 And reads ST. NICHOLAS—
 Or tries to, for she just has joined
 A kindergarten class?
 Whose papa says her grammar
 Is as shocking as can be?—
 "I do not know e'zactly,
 But I dess 'at 's me."



THE FOOLISH ELIZABETHANS



BY CAROLYN WELLS.

THESE two Elizabethans here you see
Are noblemen of very high degree;
The taller of the two
Is Sir Braggart Blusteroo,
And the other is Lord Big-wig Blusteree.

Lord Big-wig was just spoiling for a fight,
So he ridiculed his friend's excessive height;
And he said, "You look, by jingo!
Like that lanky-legged flamingo!"
And Sir Braggart was so angry, he turned white.

He retorted, "I would give a thousand pound,
If a bird that looks like *you* could but be found!"
Now his every angry word
Was plainly overheard
By two more Elizabethans standing round.

They were rustic country yokels, were these two;
They had neither wealth nor title, but they knew
Where to find a feathered creature
With Lord Big-wig's form and feature,
And for it to a market-stall they flew.

'They took it to the noble fighting fops
(Sir Braggart paid a price above the shops);

Then said, " Big-wig, you 're like that!
Silly as a goose, and fat!"

And Lord Blusteree was just as mad as hops!



Now that is what Elizabethan folks
Considered just the wittiest sort of jokes!
There 's an unauthentic rumor
That they had a sense of humor,
But I believe the statement is a hoax.

THE PENCIL BEWITCHED.



WHEN tell me, what are the tasks I must perform to win the princess's hand?" said the handsome young prince.

"There is but one," replied the prince's fairy godmother.

"Is it difficult?" the prince inquired.

"You may try it and see," she answered.

"Here is the picture of an envelop. You are to draw this without looking on the paper."

"With my eyes open?"

"Certainly," answered the fairy godmother, "but you must not look at the paper."

"Can I use a mirror?"

"If you think it will help you," the fairy said. And then, with a diagram of the envelop before him, the prince boldly set out to make a copy.

Suppose you try his experiment, and see if you find, as he did, that *the pencil had been bewitched?*



DIRECTIONS.— Place a piece of paper, pinned down, on a table. Then arrange a book, or screen of some sort, so that you cannot see your hand or pencil, except as reflected in a mirror held before you.

Benjamin Webster.



"NO, TOWSER, IF HE 'S AS CLEVER AS THAT YOU CAN'T HAVE HIM."

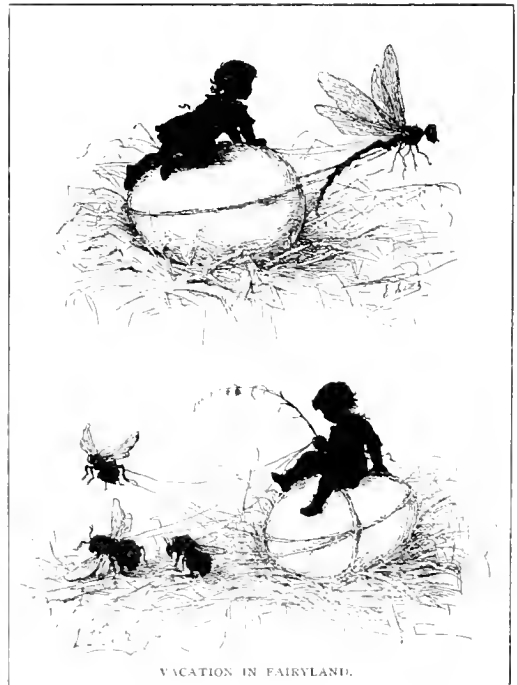

VACATION IN FAIRYLAND.

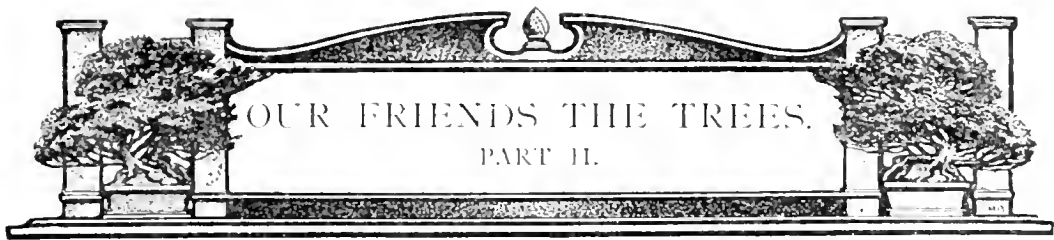

BY EDWIN W. FOSTER.

OUR public parks are very often more valuable as places for tree study than the woods themselves, because our landscape-gardeners have gathered hardy and interesting specimens from the four quarters of the globe and placed them in such positions that harmonious colors in some cases and strong contrasts in others tend to attract the attention of people who too often totally ignore every fact except that they are trees. If we will but look we will notice frequently a tree whose every branch and twig seems anxious to reach the sky, like the numberless points of a Gothic cathedral. On examining the leaf, we find it shaped like an open fan or like the tiny leaf of the maidenhair fern enlarged many times. This is one of our wonderful trees. The impression of its leaves is found in coal, and, indeed, it is believed to be the only tree which has survived the carboniferous age, that period in the world's history when coal was formed. It was preserved for centuries by the Japanese priests, who considered it sacred, and now it has been introduced into our country and is becoming one of our well-known shade-trees. It reaches a great height, is never attacked by insects which ruin many of our other trees, and may always be recognized by its peculiar thick green leaf, which turns golden yellow in the fall. By holding one of these leaves of the ginkgo or maidenhair tree up to the light it will appear that the veins radiate from a common point, like those in the leaf of a lily, and that the beautiful green color is of exceptional clearness.

All the trees we have considered so far have simple leaves. There is a large number of common trees whose leaves are called compound. A well-known example is the ordinary horse-chestnut, which, by the way, is not a

native, but an importation from Europe. In this case the indentations are even deeper than those of the Japanese maples, the leaf being divided into five or seven distinct leaflets, which meet at a common center and form the complete leaf. Our native American buckeye is built after the same fashion, but has only five leaflets, which are narrower, smaller, and not so luxuriant or dense as those of the horse-chestnut. This is one of our valuable Western trees, and judging from the fact that Ohio is called the Buckeye State, buckeye timber must have been plentiful there in days gone by. There are several varieties of buckeye, such as the yellow or sweet, the red, the purple-sweet, and the Ohio or fetid buckeye, etc. Its wood is tough and strong and makes famous farming implements.

Hickory also has a compound leaf, being related to the buckeye. There are five or seven leaflets, but instead of radiating from a common center, as in the buckeye, they are arranged along a stem in pairs, with the odd one alone at the end. There are also several varieties of hickory, some of which are well known to the boys who live near the woods, such as shag-bark, big shellbark, mockernut, pignut, bitter-nut or swamp-hickory, and the delicious pecan-nut of the South and Southwest.

This latter variety is the largest tree in the hickory family, often reaching a height of one hundred and seventy feet. It is sometimes found as far north as the Ohio River, but attains its best development in Texas, where great supplies of the popular nuts are shipped to market.

The city boy on a visit to the country is often puzzled in trying to distinguish black walnuts and butternuts in the green state. The

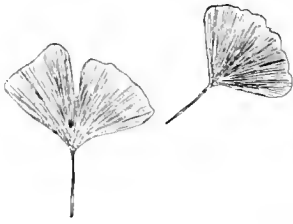

Fig. 1. Ginkgo.

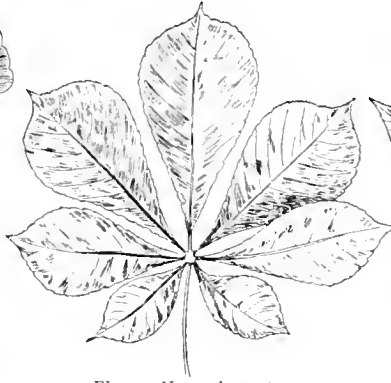

Fig. 2. Horse-chestnut.

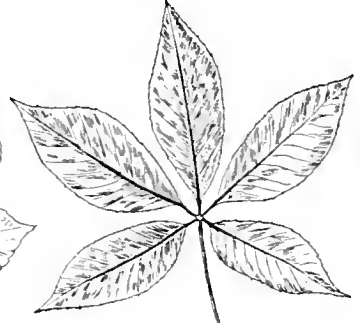

Fig. 7. Buckeye.



Fig. 4. Hickory.



Fig. 5. Butternut.



Fig. 6. Black birch.



Fig. 7. American beech.



Fig. 8. Black walnut.



Fig. 9. Yellow locust.



Fig. 10. White or gray birch.



Fig. 11. Catalpa.



Fig. 12. Honeylocust.



Fig. 13. Sycamore.



Fig. 14. Gumwood.



Fig. 15. Whitewood or tulip.



Fig. 16. American elm.

leaves are almost alike, being compound and having a variable number of leaflets arranged on a long stem. The butternut stem has from nine to seventeen leaflets, and the black-walnut



FIG. 17. AVENUE OF CEDAR TREES, THE GREAT GROUNDS, WASHINGTON, D. C.

from fifteen to twenty-three. The teeth on the latter are larger and sharper than those on the butternut, and lack the fuzzy stem, but the real distinguishing feature is the odor; having once smelled the crushed leaves of a butternut and a black walnut, a person can never fail to know them thereafter.

The nuts of the black walnut, which look so much like green lemons, are more round and not as elongated as the butternuts.

The wood of both trees is valuable in cabinet-work, walnut furniture being too common to need description; but the fact that butternut makes a handsome interior finish is not so generally known.

Many of us know the sweet birch and slippery-elm by heart, but few of us can tell the birch from the beech. A careful examination of the two leaves, however, will prove that they are not alike.

The black birch, besides the pleasant taste of the tender brown bark on the twigs, has the entire edge of its simple, delicate leaf finely toothed. These teeth seem to be not exactly simple. First the edge is toothed, then each of these teeth has one or more little teeth of its

own, giving what the botanists call a double-toothed edge, and the base of the leaf next the stem is heart-shaped or scalloped.

In the beech leaf notice that the scalloped base is missing, and the teeth—the distinguishing feature—are decidedly different, for not only are they single and far apart, but they are very shallow and the spaces concave.

Beech leaves are very smooth, thin, shiny, and delicate. The European beech, which is very common in our parks, has the spaces between the teeth so shallow as hardly to deserve the name, the result being that the outline of the leaf has a decidedly wavy appearance.

The most striking member of this family is the copper or purple beech, whose dark-purple foli-



FIG. 18. A WHITE BIRCH

age is a striking feature of our parks and lawns.

The white birch, with its paper-like bark, is another tree which takes a prominent part in the color-scheme of our landscape-gardening.

There are two distinct kinds of white birch. The one which grows so tall in the North woods, the canoe-birch, has a tough white bark



FIG. 19. A BLACK WALNUT

which is waterproof, and was formerly used by the Indians for canoes. It is a large tree, and its name paper-birch comes from the formation of the bark in layers, which separate as readily as sheets of paper.

The smaller white birch, which is becoming so common on Long Island, sometimes called gray birch, is an entirely different tree with a characteristic leaf. You will find no tree in the forest with a leaf like this one of the gray birch. Notice the broad, flat base, then the graceful, gradual taper out to a fine point, and the sharp teeth. The long, slender stems allow the leaf to be fluttered like an aspen by every breeze until the whole tree, with its long, drooping branches, is one mass of glimmering green and silver.

This tree is much smaller than the paper-birch, and its bark is not as white, nor does it separate in layers easily like the canoe-birch. It is much more delicate, and makes a handsome addition to any lawn.

In dealing with contrasts in leaf forms, perhaps no greater contrast can be found than between the leaves of the catalpa and honey-locust. The boys will quickly remember the catalpa-tree when we remind them that it produces long, round beans which sometimes are nearly eighteen inches in length, and which are sometimes "smoked" by mischievous and adventurous boys. The leaf is very simple and

enormous in size, often approaching the palm-leaf fan in its dimensions. Placed side by side with the delicate and refined spray of the honey-locust, we wonder if Nature has not tried to see how infinite are her range and power to create beautiful and ugly forms.

The locust family seems particularly fond of thorns, even the common yellow and clammy varieties being well supplied with them.

Aside from this disadvantage, however, the tree is a valuable one, the wood being very hard and durable. It is in particular demand for fence-posts and other timbers which are to be in contact with the ground. These parts of fences or buildings are always liable to early decay and attacks of destructive insects, yet the yellow locust is able to withstand all these enemies, animate and inanimate, for a century. The nearest wood to this in point of durability is the cedar, which is famous for its lasting qualities.

No list of American trees would be complete



FIG. 20. A PURPLE BEECH.

which did not include the three forest giants, buttonwood, sweet-gum, and tulip.

The various names of buttonwood, button-



FIG. 21. A TULIP OR WHITEWOOD.

ball, sycamore, and plane tree, as it is called in different parts of the country, all suggest that typical American tree which sheds its bark as well as its leaves, leaving a ghostly and gaunt monster of freedom which produces an enormous crop of buttonballs so well known to every country boy and country girl.

Its leaves are in proportion with the trees, great in size, often measuring a foot in length, and being frequently covered on the under side with a heavy growth of fungus. The wood of the sycamore, as it is erroneously called, is valuable for cabinet-work, having a beautiful grain and taking a high polish.

The sweet-gum tree also produces a crop of "balls" or seed-pods, but although about the same size as the buttonballs,—an inch in diameter,—they could never be confused, as the gumballs are covered with rather sharp points, while the buttonballs are smooth.

The leaf of the sweet-gum—so called from

the amber-colored gum the tree gives out—reminds one of the starfish, being five-fingered and quite different from any other tree in the forest. This tree grows very tall, and its wood is a beautiful brown color with fine and intricate grainings. It is, however, liable to warp excessively, but not withstanding this it is much liked by wood-turners on account of its softness and even grain.

The lumber furnished by the tulip-tree, commonly called whitewood, is more valuable than that of the sweet-gum; although why it should be called whitewood is not clear, as it is of a greenish-yellow color, much darker than white pine.

This tree is remarkable for its individuality. Its foliage is not so dense as many of our other trees, but each leaf stands out conspicuously and aggressively, as if it had a will of its own. The shape of the leaf also expresses the independent character of the tree, and when it has once been seen it will never be forgotten.



FIG. 22. THE AMERICAN Sycamore.

Reterring to the diagram, it will be seen that the end seems cut off very abruptly, as though another point had once been there but had

been cut abruptly off as with a pair of scissors.

The flowers the tree bears in the spring give it the name tulip. These blossoms, which fairly cover the tree, are shaped like a tulip and are frequently as large as from three and a half to four inches in diameter. This famous tree is a giant among giants. Specimens seven feet in diameter and a hundred and fifty feet high have been found in the Southern States, where it reaches its fullest development.

And, lastly, we must take off our hats and make our most profound bow to the stately elm, the tree which has been considered typical of American, particularly of New England, char-

acter—graceful, dignified, sturdy, straightforward, and useful. One can hardly conceive of such New England towns as New Haven, Concord, or Lexington stripped of their elms; they would indeed be different places. The shape of the tree is a gradual, almost imperceptible spread as the branches leave the main trunk. One good feature of the tree is that its foliage is so high above the ground that it does not obstruct the view, and yet it gives an ideal shade.

An avenue bordered on either side with elms which meet high overhead is a sight to be remembered, and reminds us of the noble arches of a Gothic cathedral.

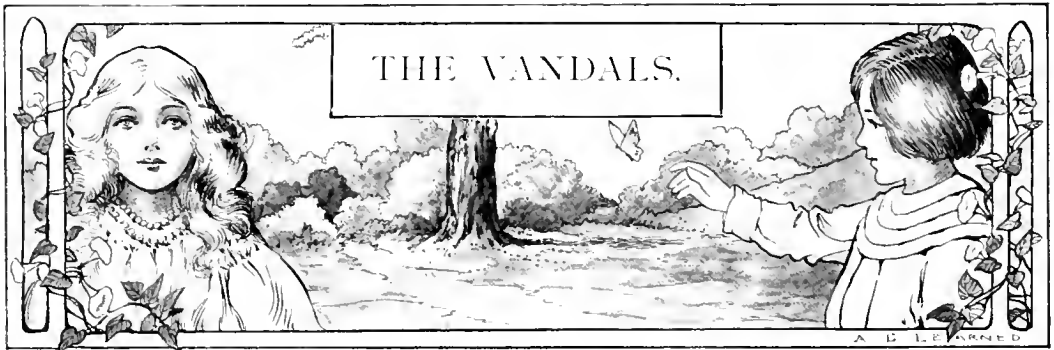

BY LUCY L. CABLE.

Down beyond the garden wall
They have cut down the maple-tree;
But they who cut it cannot know
The loss to you and me.

They think to build themselves a house
Where long our tree has stood—
Our tree that was a house of leaves,
Fairer than house of wood.

Will they see the wondrous sights we saw,
From their windows made of glass?—

The wingèd clouds, the marching sun,
The shadow-ships that pass?

We saw the Spring come up the land,
The Autumn's flags flung out;
We felt the South Wind kiss our hair,
And answered the West Wind's shout.

Their house of wood will higher be
Than our tree-house in the air;
Yet they will not live so near the sky,
Nor see what we saw there!

THE PRACTICAL BOY.

BY JOSEPH H. ADAMS.

EIGHTH PAPER.

I. TENTS, HOUSE-TENTS, AND CAMP FURNITURE. II. WATER-WHEELS.

A NEW TENT.

ONE great drawback to the pitched or army tent is that in wet weather, when one has to stay within, it is not a comfortable abode unless you sit down or keep close to the ground; for there is little or no head room, excepting directly in the middle.

In Fig. 1 is shown a new form of tent which, even in the smaller sizes, will admit of a boy's standing up when close to the side-walls. Two uprights, three ridge-poles, and four angle-bars will be required for the frame, and

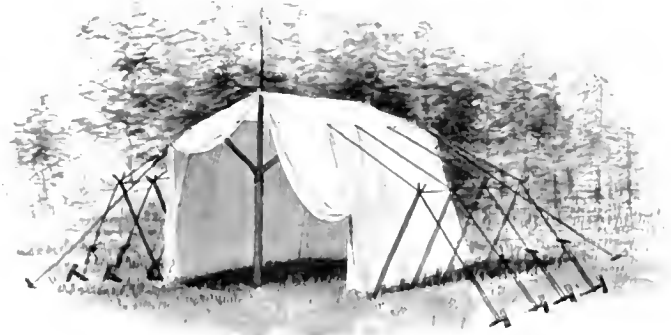

FIG. 1. A NEW TENT.

out from the tent, as shown in the illustration, for then there will not be such a down drag on the side ridge-poles. For a party of three or

four boys this tent should be 7 feet 6 inches high, 6 feet 6 inches broad at the top, 8 feet at the bottom, and 10 or 12 feet deep. The sides and top are in one piece 21 feet long and 10 or 12 feet wide. The back end is made in one piece and sewed fast to the edges of the sides and top. At the front two flaps are sewed to the top and sides. They each measure 7 feet 6 inches long at the inner edge,

4 feet across the bottom, 3 feet 5 inches at the top, and 7 feet at the outer edge. They are cut as shown at A

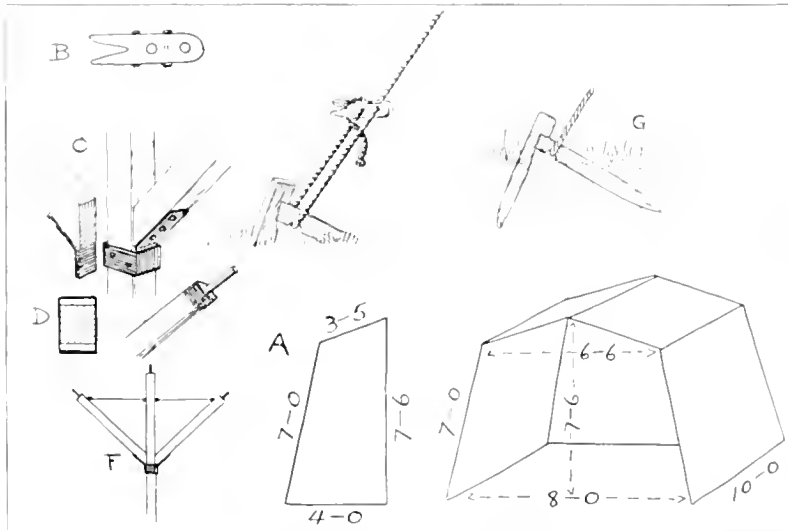

FIG. 2. DETAILS OF THE NEW TENT.

when in the woods some long, slim poles with crocheted ends can be cut to prop the guy-ropes

the outer edge. They are cut as shown at A

in Fig. 2. The frame is composed of two uprights 2 inches square and 9 feet long, 18 inches of which is let into the ground; three ridge-poles 2 inches in diameter and 10 feet long; and four brace-bars 2 inches square and 4 feet 3 inches long, beveled at the lower ends to fit against the upright post, as shown at C. An iron pin is driven in the top of each upright and at the outer ends of the brace-bars over which the ridge-poles fit, they having been provided with holes to receive the pins. Angle-irons are sewed fast to the beveled ends of the brace-bars, and a collar of iron is made and screwed fast to the uprights so the tongue end of the angle-irons will fit in them, as shown at D. Stout screw-eyes and wire hold the braces in position at the top, as shown at E, and prevent the outer ridge-poles from straining the canvas. One of the best anchorages for the guy-ropes of a tent is made with the lock-stake and dead-eye cleat shown at G. The dead-eye cleat (B) is 2 inches wide, 6 inches long, and provided with two holes 3 inches apart. At one end a jaw is cut so that a rope may be caught in it, and steel-wire nails are passed through holes indicated by the dotted lines and riveted at the point ends to strengthen the dead-eye. In driving the lock-stake, care should be taken not to slant either peg so much that not sufficient earth will be over it, else it will not hold when a sudden pull is given to the rope.

A LARGE CAMPING-TENT.

For a company of boys numbering from four to eight, a large camping-tent is shown above in Fig. 3; which, if made 20 feet long, 10 feet wide, and 8 feet high to the ridge-pole, will accommodate six cots and two hammocks. Three uprights 2½ inches square can support the ridge-pole, which is in two pieces

lapped at the middle. A fly 20 feet long and 18 feet wide is supported over the tent, where, in clear weather, it can be propped up at the outer edges, as shown at the left side in the illustration. The fly is drawn back at the right side to show how the guy and stanchion ropes are attached to the stakes so as to prevent the wind from blowing the tent backward and forward as well as from side to side. All around the lower edge of the tent ¾-inch harness-rings should be sewed fast about 12 inches apart, by means of which the apron end can be tied fast to short stakes or wooden pins driven in the ground to prevent its flapping.

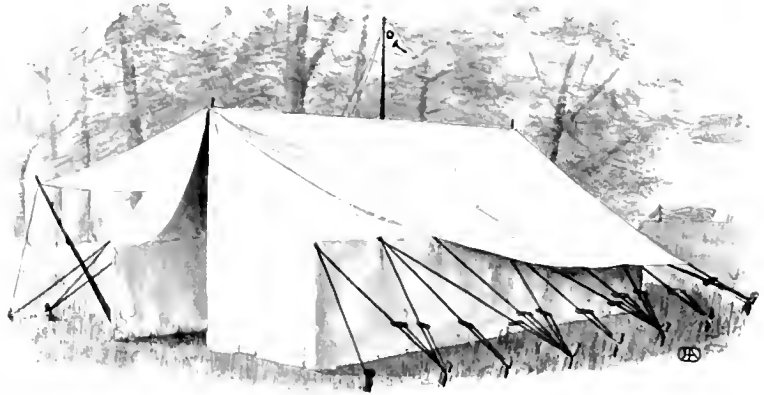

FIG. 3. A LARGE CAMPING-TENT.

If possible, provide the tent with a board floor raised a few inches from the ground.

TABLES AND BENCHES, FLIES, CANOPIES, AND BEDDING.

A LARGE and strong table is shown at H in Fig. 5. The boards, three or four in number, can be from 6 to 8 feet long. They are nailed fast to 4 or 5 inch rails attached to the tree-trunks and to stout posts embedded in the ground. The middle of the table is supported by a batten or rail which is mounted on or nailed fast to the top of a post embedded under the center of the table.

Chairs that can be made for camp life from rustic wood and pieces of board need not be so well put together that any great amount of time must be expended on their construction;

but they should be strong and serviceable, if not very beautiful.

A simple chair, that almost any boy can make



FIG. 4. A CANOPY AND FURNITURE.

from branches or small tree-trunks 2 or 3 inches in diameter, is shown at A, B, and C of Fig. 5.

The seat is 18 inches high and 16 inches square, and the back posts are 36 inches high.

In the illustration of a canopy (Fig. 4), a table and benches are shown. The table is 36 inches wide and 5 feet long, and it can be built either detached or fast to the ground.

Two benches, running the length of the tables, are made in a similar manner to the chairs.

The table and benches may become fixtures if the same camp is made each year, and in that case the furniture can be made stronger and better than if used for only one season.

Every camping-tent should have a fly,—that is, an extra canvas roof,—for no matter how good the canvas of which it is made may be, it will become thoroughly soaked in a heavy rain; but if protected by a fly which practically covers it, the fly will lead the water off and receive the greater part of the wetting. Fig. 3 shows a tent with the fly partly turned back.

In fair weather, when it is possible to dine outside the tent, the fly can be used as a canopy if drawn over the ridge-pole and held up at the ends by means of poles and stanchion-ropes, as shown in Fig. 4.

A canopy over a fire will keep rain off and make it possible to burn the dry wood necessary to cooking, and may be used as well to keep fuel under, and the extra rustic chairs and tables that can be made in the woods for use about the camp.

Fly- or canopy-ropes should be bound with rope all around the edges to prevent tearing, and at distances from 12 to 18 inches apart 1/4-inch harness-rings should be made fast, so that stanchion-ropes can be reeved wherever it is necessary to attach the sheet to branches or poles set in the ground for its support or anchorage.

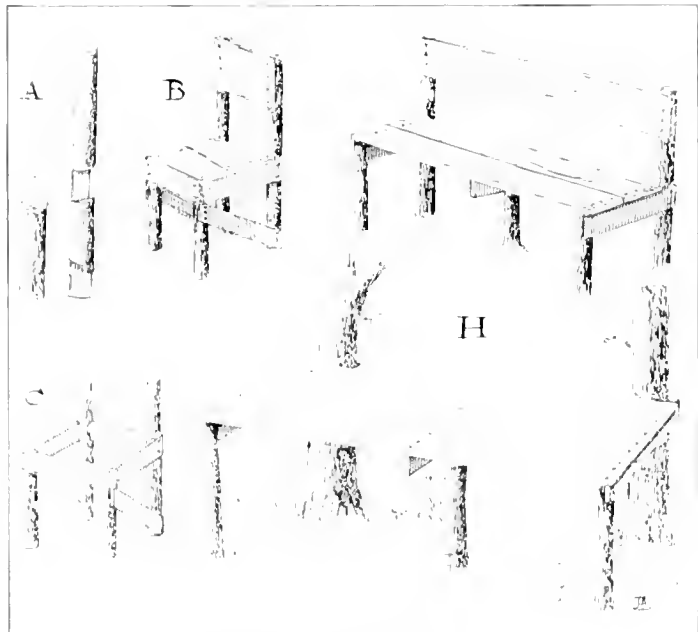

FIG. 5. DETAILS OF CHAIR-FURNITURE.

In Fig. 6 is shown one end of a simple camp cot. The canvas can be sewed with a loop

fold along the entire length of the sides before leaving home, and the side poles and forked

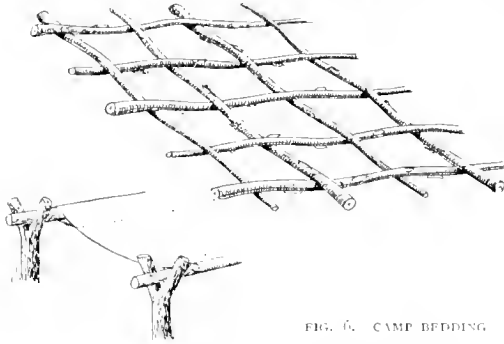

FIG. 6. CAMP BEDDING.

stakes can be cut at the camping-place. For strength the stitching should be in several rows, else it will tear out if a sudden weight is thrown on it.

When making a cot of boughs the most satisfactory and comfortable affair is the basket-woven or lattice mattress of small pliable saplings, trimmed and interwoven, as shown in Fig. 6. The long pieces should be so laid that the large end of one stick will be next the small

where at least six months of each year are spent out of doors.

The frame is 12 feet long, 8 feet wide, and 9 feet high from the floor to the peak. The wood sides are 3 feet 6 inches above the floor, and out beyond one or both sides of the house the joists may extend to support one or both of the wood sides, which, if hinged along the bottom, can easily be dropped to act as piazzas, thereby giving additional room in fair weather. The framing shown in Fig. 9 is 2 inches square, with joists for the under timbers. The joists or flooring-beams rest on the ends of posts embedded 2 feet in the ground, to which they are spiked with long steel-wire nails. The flooring, of 4-inch matched boards, is laid on the space within the four corner uprights, and the same or wider boards can be employed for the siding or sheathing (see Fig. 9). The triangular end-pieces of canvas are attached to the frame with copper or tinned tacks, so they will not rust, and the roof and both sides

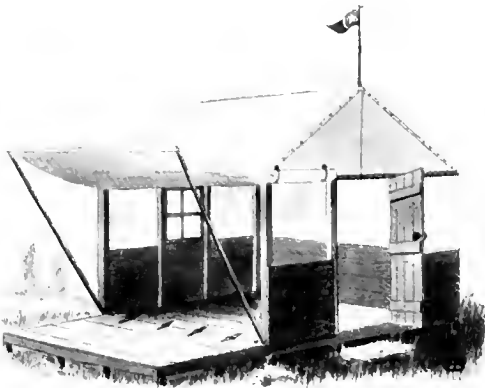

FIG. 7. A HOUSE-TENT—OPEN.

end of another, so as to distribute the stronger parts of the wood evenly all over the lattice.

This arrangement applies also to the shorter or cross-pieces, and when finished the mattress is laid on a pair of poles supported with crotched sticks, as shown in Fig. 6, but without the canvas.

A BOARD-AND-CANVAS HOUSE-TENT.

THIS style of camp has become very popular in California and through the Southwest,

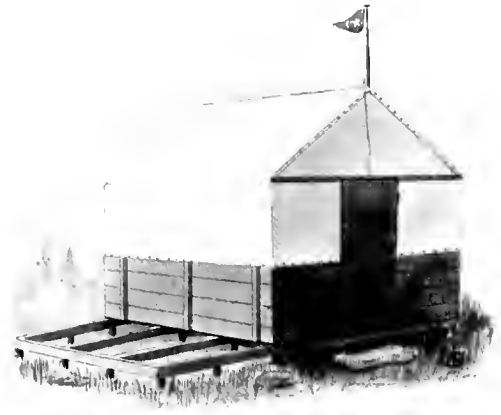

FIG. 8. A HOUSE-TENT—CLOSED.

are of one piece, made by sewing lengths of canvas or twilled sheeting together. At the front and back it is drawn over the edges of the end-rails forming the roof, and tacked to hold it in place; while at the top of both sides the edge may be tied to galvanized nails driven in the wood, or caught over curtain-buttons such as are used on carriages, and which can be purchased from a carriage-maker for a small amount.

At the front, on either side of the doorway,

the canvas may be arranged to roll up in clear weather, and be, after the manner of carriage-curtains, held to the upper frame-bar with cords or straps. The side that lets down to form the piazza is battened on the outside, as the first illustration shows, so that when the side is down the battens drop in between the extended floor-joists.

It will be well to bear in mind that if the side is left open as shown in Fig. 7, and a sudden rain-storm comes up, the rain will tend to fill up the gutter formed by the slanting roof and the slanting canopy. This can be avoided by lowering slightly the two supports in order to give the canopy more of an "outboard" pitch. Perhaps it would be better still to set the pitch of the canopy roof so that it will always be ready for a rain-storm.

When the camp is broken in the fall, the canvas should be removed from the framework and kept for next season, but the frame may be left standing, first having removed the door and sashes and slid them under the floor, for they would offer resistance to the wind if left standing in place, and might break or cause the framework of the house to rock and become rickety during the winter

storms and high winds; or the window sash might be nailed temporarily to the lower wood sheathing. As the frame is to stand through the winter without any roof, thus exposing the joints, it will be a wise precaution to give the ends of the timbers a coat of thick lead paint before they are nailed together.

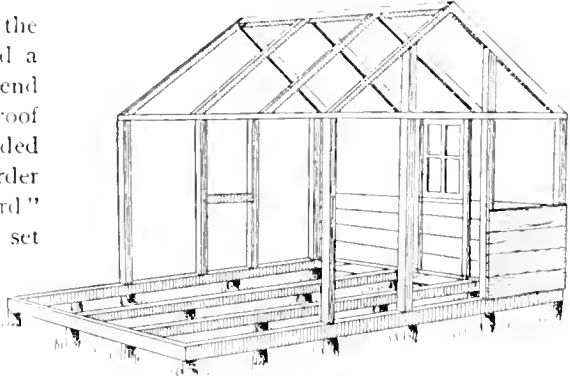

FIG. 9. SHOWING THE FRAMING OF THE HOUSE-ENT.

A coat or two of paint on the woodwork would improve its appearance greatly and preserve the wood if the house is to be used for a number of seasons. It is very little work to do this, and the advantage far outweighs the trouble necessary.

WATER-WHEELS.

IN camping, if there is a waterfall or rapidly running brook near your camp, the power that can be derived from its flow will run a water-

days, pumping water, and lending its aid to save your labor in various ways. There are three kinds of wheels, the overshot, breast, and under-

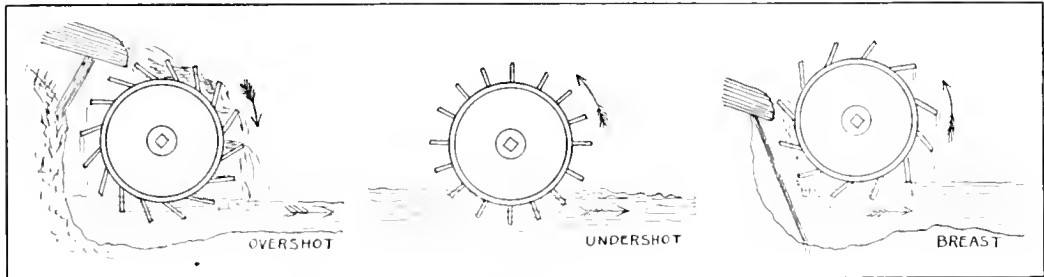

FIG. 10. SHOWING THE DIFFERENT KINDS OF WATER-WHEELS.

wheel, which in turn can be made to serve your purpose in many ways. Once you get a wheel in operation with a shaft and pulley attached, it is then a simple matter to harness your power and make it do all sorts of things, such as sawing wood, grinding coffee, operating a fan on hot

shot. The overshot is the most powerful, for it is not only moved by the weight of water it holds, but by the force of the onrushing water from the sluice arranged to feed it from above. The breast-wheel is the next in power, and is used where the fall of water is not so great.

The undershot wheel is employed in a rapidly running stream, where there is no dam or body of head water. This form is the least powerful and the most unreliable, but is easy to construct as it requires very little preparation.

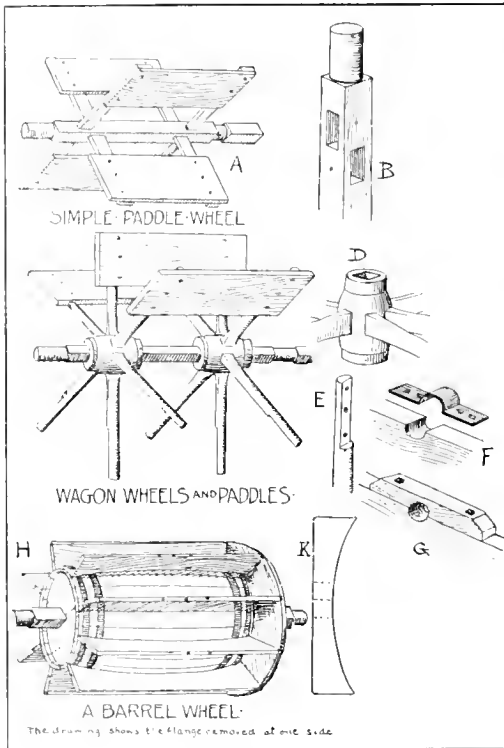

FIG. 11. DETAILS OF WATER-WHEELS.

In Fig. 11 several ideas for water-wheels are shown, and among them a boy should be able to find one that he can easily make from boards and sticks at a slight cost, and which, if properly rigged and adjusted, will develop a considerable amount of power. A simple paddle-wheel (A) is made from an axle 3 inches square, four spokes, and four boards. For a wheel of medium size that will develop about one eighth of a horse-power the axle can be 4 feet long. One end is rounded for a distance of four inches, as shown at B, and with bit and chisel two mortises are cut in opposite directions, as shown also at B. These holes are $1\frac{1}{4}$ inches wide and 3 inches long, and into them the spokes are driven and held with screws or iron pins. Another pair of holes are cut 30 inches from the first and two more spokes driven in them.

The spokes are 30 inches long, thus leaving $13\frac{1}{2}$ inches of each one projecting beyond the axle or hub. The paddle-blades are boards 30 inches long, 10 inches wide, and $\frac{7}{8}$ of an inch thick. They are attached to the spokes with carriage-bolts and washers. A rounded bearing 2 inches wide is cut in the axle beyond the spokes so as to correspond with the other end, and beyond this the axle is left square. Bearings for this wheel are made in the edge of a stout plank notched as shown at F, and held in place by iron straps. Long screws or screw-bolts, commonly known as lag-screws, will hold the straps in place, and from the square end of the shaft the connection is made for power. In place of an iron strap another piece of wood may be cut and clamped down over the axle end as shown at G.

Another water-wheel can be made from the hubs and spokes of two old wheels, preferably those from a buggy or light wagon. Remove the iron boxes from the hubs by driving them out, then cut a hole in each hub with a chisel and mallet, as shown at D, so they will be at least $1\frac{1}{2}$ inches square. From hickory or other hard wood make an axle the size of the holes, and arrange the hubs on it so they will be thirty inches apart. One side of each spoke should be cut as shown at E, so the blades will lie against a flat place instead of against the rounded surface. The blades can be from 30 to 36 inches long and 10 or 12 inches wide, and held to the spokes with carriage or tire bolts.

This wheel can be swung in bearings as described above, and from the square end of

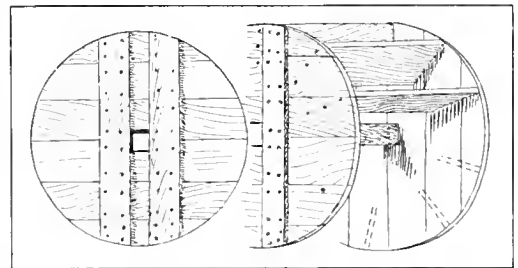

FIG. 12. DETAILS OF WHEEL SHOWN ON OPPOSITE PAGE.

the axle the power can be taken. Both of these wheels can be used as overshot or undershot, but not as breast-wheels, for a breast-wheel must have pockets to hold the water, and the

overshot wheel should have them too if the force and weight of water are to be counted on for all the power available.

A very simple and efficient device of a barrel-

and into these holes an axle is driven. It is provided with the rounded bearings and square end, and when swung in a carriage and connected a powerful wheel will be the result.

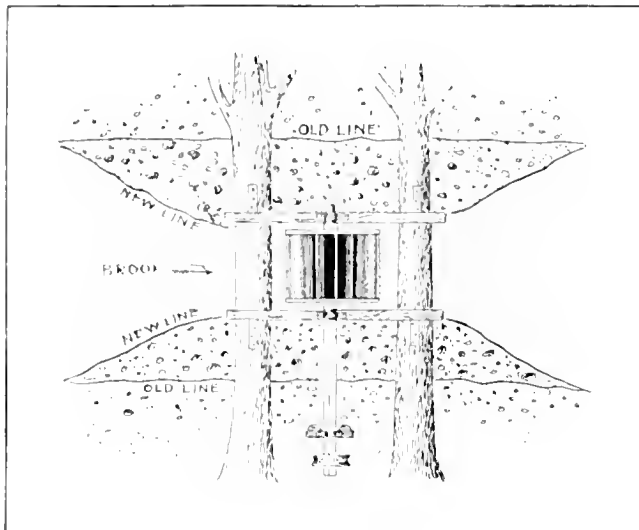

FIG. 13. DIAGRAM SHOWING HOW A STREAM MAY BE NARROWED TO PERMIT THE USE OF A WATER-WHEEL.

wheel is shown at H in Fig. 11. This consists of an oil or pork barrel having tight ends and staves, a number of blades, and some siding boards. The blades are of hard wood 10 inches wide and the length of the barrel. One edge of each blade is cut to conform with the bilge of the barrel, as shown at K, and with three or four long screws each blade is made fast to the barrel at the middle. The ends of the barrel are replanked so as to build their surface even with the projecting edges of the staves, then some matched boards are nailed or screwed to the ends to bind the ends of the blades. Screws are passed through the boards and into the ends of the blades to make them secure, and in this manner a hollow wheel is made with pockets around the outside. A square hole is cut in each end of the barrel,

anchor them well with spikes and chock-blocks.

The various illustrations in this article must be considered as only suggestions for boys. Especially with regard to water-wheels, the conditions of the country in which they are to

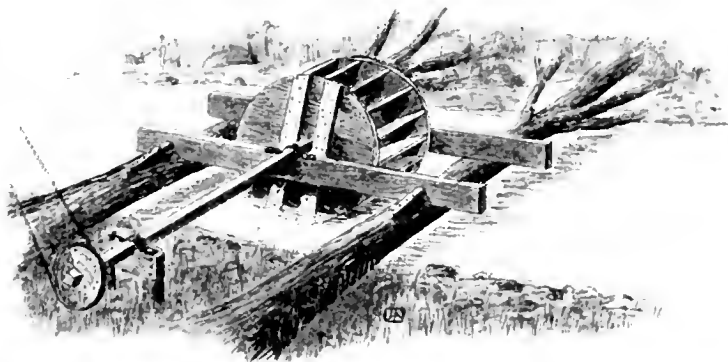
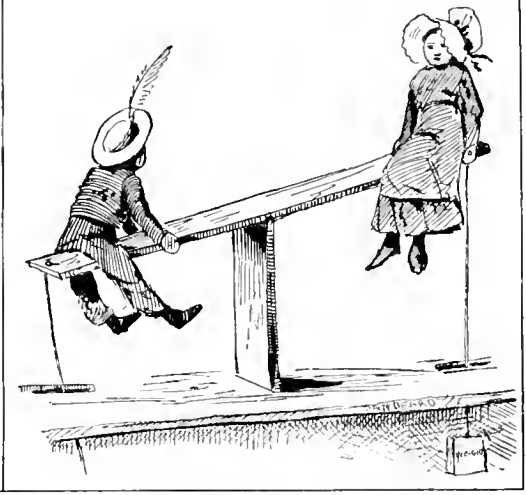
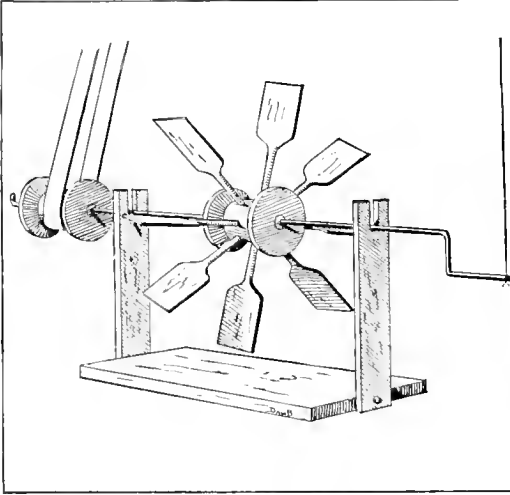

FIG. 14. THE WATER-WHEEL IN OPERATION.

be used will determine which kind of wheel is desirable. Then the time at the boys' disposal must be considered; for it would be folly to attempt an elaborate water-power plant if the vacation were very short.



While on the subject of water-wheels, here is a postscript. An elder brother will be interested in the illustrations on this page, which suggest to him how he can amuse his younger brother or sister. The hub of the water-wheel

is made of a spool, and dolls and jumping-jacks serve as the performing company. No description is necessary, as any handy boy who has followed "The Practical Boy" articles will be more than equal to this toy water-wheel.

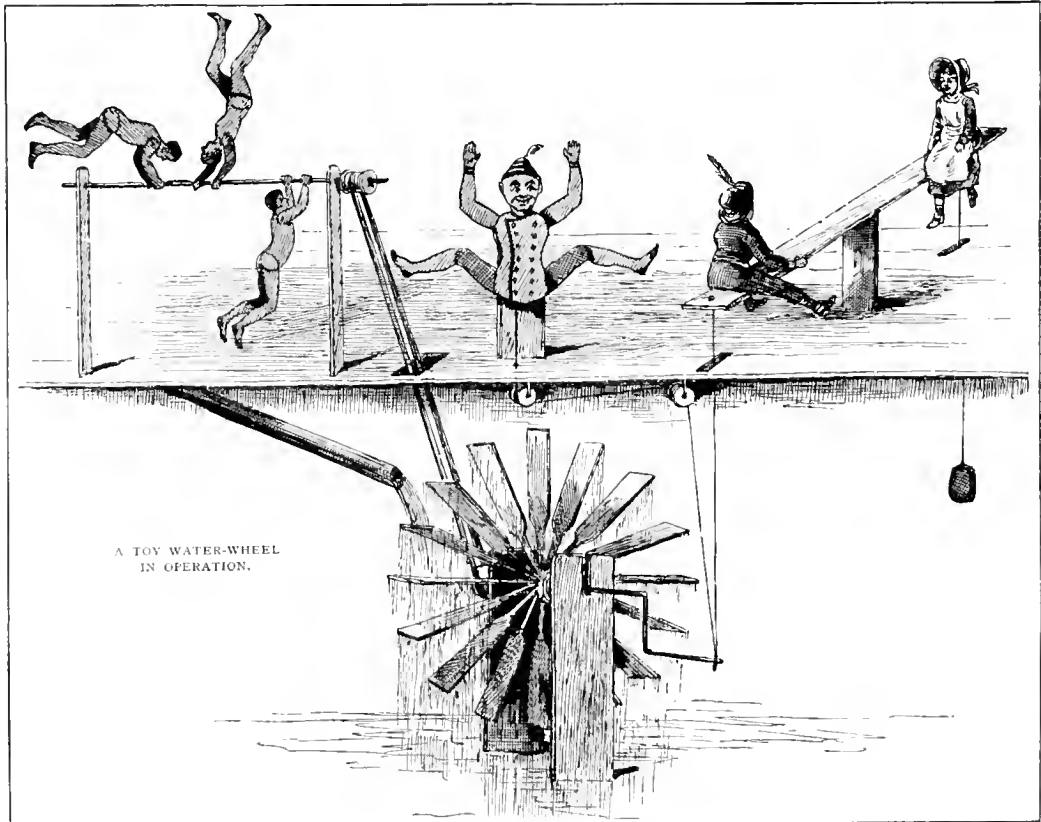

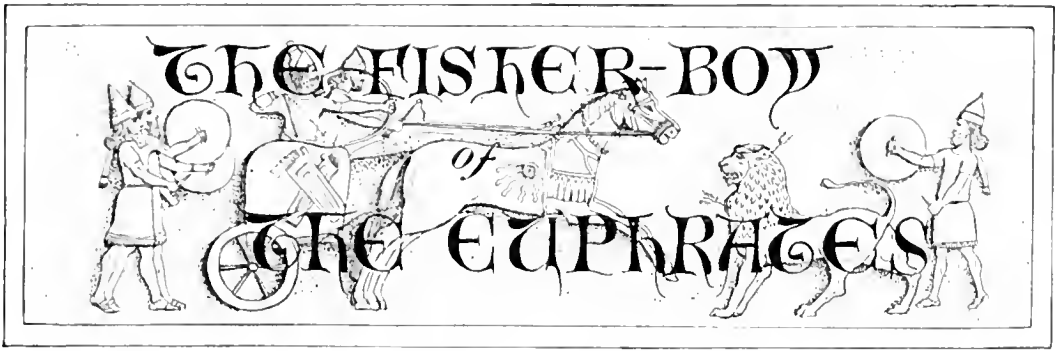

BY MARGARET JOHNSON.



OH, as brown as a nut from
his bare little toes
To the tip of his truly Assyrian nose,
The fisher-boy, little Tiglates,
Among the tall rushes sat
fishing for carp
With a line very long and a
hook very sharp,
As he sat every day,
Merry-hearted and gay,
And fished in his ancient Assyrian way,
By the banks of the river Euphrates.

A cloud on the highway, a sound in the air,—
Now who could be coming, his fishes to scare,
And his basket not yet over-brimming!
His line from the water he carefully drew,
And after a gay little flourish or two
On the pipe he had made
From the rushes that swayed
In the river, a tune so enchanting he played
That the fishes to listen came swimming.

But the king was out hunting that day by the shore
Some twenty ferocious big lions or more,
And 't was this that had startled Tiglates;
With thunder of hoof-beat and rattle of wheel,
And shimmer of satin and sparkle of steel,
The grand cavalcade and the royal parade
Their glittering way, as it happened, had made
To the banks of the river Euphrates.

But even a king may grow weary in time
Of a royal amusement, however sublime,

And now by the river he halted;
His bow was too heavy, his arrows were dull,
His fan-bearers served but the breezes to lull;
The flies they were rude,
And the sun would intrude,
And in short his Assyrian Majesty's mood
Scarce befitted a rank so exalted!

The king, as he turned his imperial frown
On the stream, for presuming to spatter his gown,
He spied in the rushes the fisher-boy brown,
With his pipe and his basket of wicker;
And, seized with a sudden and royal caprice,
He vowed he must have for his supper a piece
Of that very same fish;



"THIS RAN THE PRIME
MINISTER, FLORID
AND FAT."

And 't was also his wish
That the piper should
play, ere he tasted
the dish,
That the moments
might pass for
him quicker.

Then ran the prime
minister, florid
and fat,
In a little gold fillet
instead of a hat,
And a lot of gold tas-
sels and fringe
and all that,

And a dozen proud nobles behind him;
And down on the wondering fisher they pounced,
And the fish from his basket they speedily
bounced,

And bore him away,
 Never stopping to say
 "By your leave!" for his Majesty's humor that
 day
 Made it wise very promptly to mind him.

In state on his throne with its purple-fringed
 tent
 (For he carried one with him wherever he
 went),
 And its cushions with gold interwoven,
 He sat, while Tiglates, a trifle abashed
 By the splendor that round him, bewildering,
 flashed,
 Played a melody clear,
 And—you *may* think it queer!—
 Quite as sweet to an early Assyrian ear
 As the music of Bach or Beethoven.



"THEY BORE HIM AWAY."

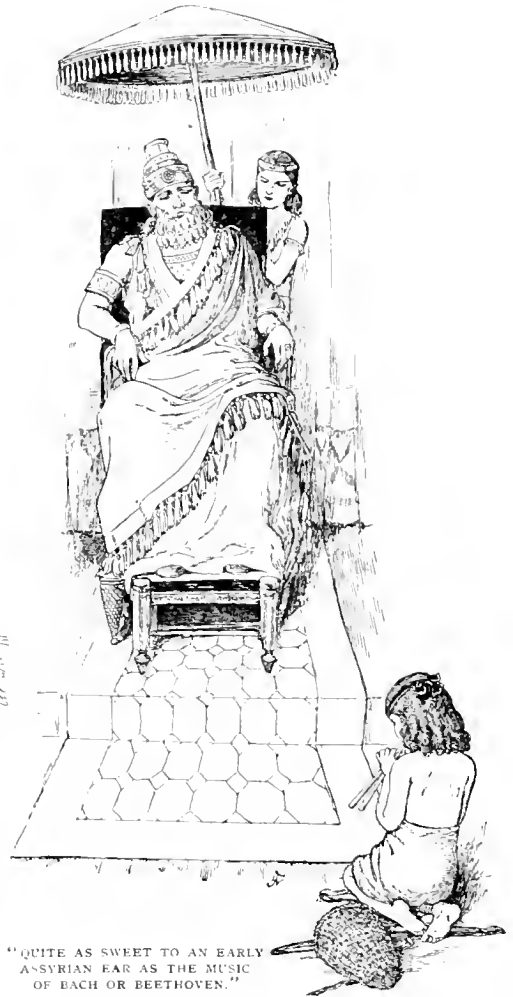

"QUITE AS SWEET TO AN EARLY ASSYRIAN EAR AS THE MUSIC OF BACH OR BEETHOVEN."

The king was delighted. "This fisher," he cried,
 "No more in the wilderness here shall abide!
 He shall come to my palace, shall stand at my
 side;

For, whatever his name and his fate, he 's
 A genius!" And straight, ere the boy could
 draw back,
 They had hustled him into a—no, not a hack,
 But a chariot proud;
 And away like a cloud
 He was whirled, with the rest of the glittering
 crowd,
 From the banks of the river Euphrates.

Now all of the wonderful things that befell
 At the end of the journey, I really can't tell,

For the time, if we tried it, would fail us.
Each room in the palace was big as a church,
And although for a window in vain you might
search,

There were portals a score,
And beside every door
Such a great winged bull as delighted of yore
The mighty King Sardanapalus.

Here little Tiglates, the fisher unknown,
They dressed up in silks of an exquisite tone,
Perfumed with Assyrian eau-de-cologne,
And embroidered with sphinx and with
griffin;

He played for the king, and right merrily, too;
Yet—I know you will hardly believe it is true
That he had, with all this,
The presumption to miss
A low hut by the river, while tasting the bliss
Of a feast in his Majesty's arbor!

But for halls that were splendid and bulls that
were big,
If the truth must be spoken, he cared not a
fig,
Nor for garments of tints that were Tyrian;
He wanted his mother, he wanted his home,
He wanted the dear muddy marshes to roam,

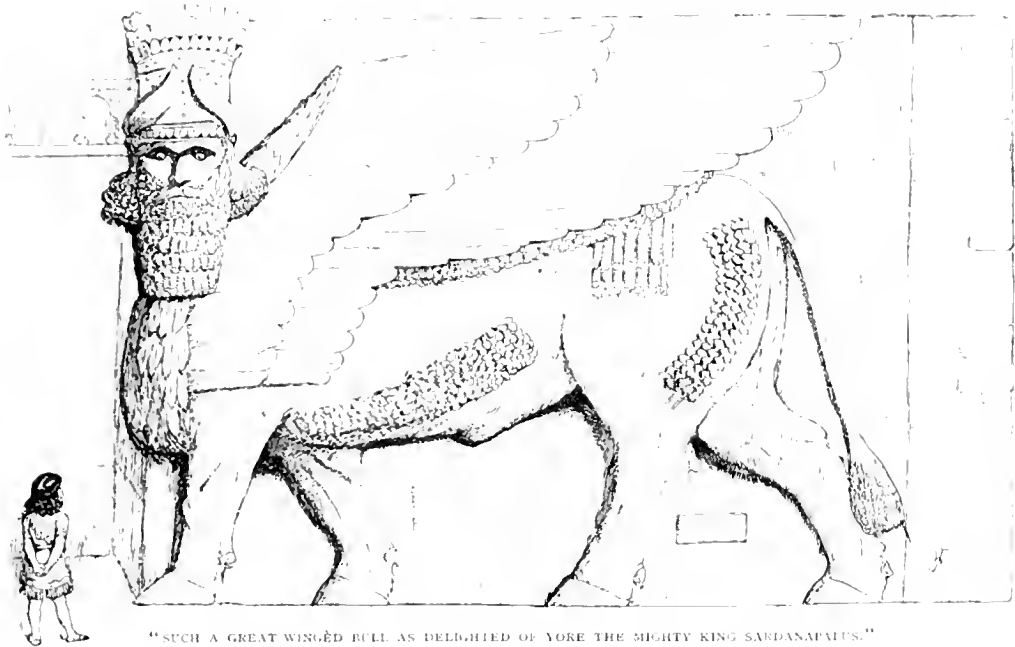

They fed him with locusts (you would n't like
that!),

Pomegranates, pineapples, and partridges fat;
They showed him the queen,
Who, majestic of mien,

Could n't move (so I judge from the pictures
I've seen)
For the jewels her garments were stiff in!

They showed him the gardens, the pride of the
world;

They had all his ringlets exquisitely curled
By a fine Babylonian barber.

And the reeds by the stream
Just a beautiful dream
Had begun, ere the first day was ended, to seem
To the poor little homesick Assyrian.

And when, at the close of the banquet, the king,
Who a boon to this gem of a piper would fling,
"Your wish?—it is yours, by the seal on my
ring!"

Cried aloud to the waiting Tiglates,
The heart of the boy overflowed like the tide:
"Oh, your Majesty's pardon!" (he knelt as
he cried,)

" I have but one wish,—
 To go back to my fish,
 And to hear the sweet waters that ripple and
 swish
 By the shores of the river Euphrates!"



" THEY SHOWED HIM THE QUEEN."

The king almost fainted; his lady likewise;
 The waiters they staggered with doubt and
 surprise,

And the guards fairly reeled in the gate-
 way:

A fisher, who might have had favors galore,
 And who asked but for freedom to roam by the
 shore,

In a solitude dread!—

Well, the word it was said,

And the king rather peevishly nodded his head,
 And dismissed the whole circumstance
 straightway.

That brave little lad, ere the morning was done,
 For joy fairly danced and hallooed in the
 sun

(From the monarch, of course, a safe dis-
 tance!).

And went speeding away in a chariot proud
 Over meadow and marsh, like a glittering
 cloud;

And with never so much as a penny endowed,
 Bare and brown as before,
 He was dropped at his door,



And he never saw horseman or chariot more,
 All the days of his happy existence.

You think 't was a pity? Why, then you have
 missed—

And 't is yours to find out—of my story the
 gist!

For to roam like the breezes wherever you list,
 Or to dwell in exceedingly great ease
 Shut up in a palace, with pleasure and pelf,—
 Why, even King Sardanapalus himself,
 In his sovereignty high,

Might have thought with a sigh
 Of the fisher, content with the reeds and the
 sky

By the banks of the river Euphrates!





A TYPICAL VIEW OF THE FOX COUNTRY.

PHOTOGRAPHING A WILD FOX.

BY SILAS A. LOTTRIDGE.

THROUGHOUT the wooded districts of Otsego County in New York State, west of the Glimmerglass, there are to be found a considerable number of foxes. The natural conditions for the protection and even increase of this species of wild animal exist there to a marked degree. Although the woodsman has worked great havoc among the pines, hemlocks, and chestnuts that once covered the high hills of the district, here and there even now may be found a comparatively large forest. The ground, when cleared, not being suitable for agricultural purposes, it has been allowed to run wild, and a luxuriant growth of scrub-oak, pine, and cherry, a few evergreens, and a tangle of brier have taken the place of the larger timber. The whole section, therefore, offers ideal homes for the foxes.

It was during the tapping of the sugar-bush that some boys noticed numerous fox-tracks in the snow. They also caught an occasional glimpse of a long, slim body gliding as silently as a shadow into the dwarf hemlocks by the swamp, and the watchers of the sugar-camp at night were often startled by shrill barking just

outside of the circle of light. This reminded the boys of the gradual disappearance of their father's fowls and the oft-repeated threats against Reynard, and they determined, when the hurry of sugar-making was over, to turn their attention to the destruction of their troublesome neighbors.

The motive of my interest in the foxes was very different from that of the farmer and his family, with whom I was staying, so that my enthusiasm was less easily dispelled. I was bent, not on their destruction, but on learning more of their habits and real life,—how they cared for their young and protected themselves from the many dangers that beset them,—and on obtaining, if possible, some photographs of wild foxes.

One day, while in an old stump-lot which sloped south, I caught a glimpse of a large fox as he disappeared behind a knoll and then reappeared a little farther on. He trotted leisurely across the open pasture, never once turning his head or in any manner indicating that he had seen me. He was not fifteen rods away, and

would have been an easy shot, but I would not have killed him for all the poultry in the farm-yard. I immediately seated myself by an old



BAIT FOR THE FOX.

stump and focused my field-glass upon the beautiful animal. I had no sooner done this than the fox, which probably had been watching me all the time, sat down, dog-fashion, and turned his gaze full upon me. For ten minutes there seemed to be an equal fascination between man and fox, and then a sudden change came over the fox. My perfect quietness seemed to disturb him. His frequent change of position, the occasional opening of the mouth, and other quick, nervous movements, told very plainly of the strain he was undergoing.

During this time I had lowered the glass and was gazing intently at him, and never for an instant did he take his eyes from me. I was at a loss to know how to proceed, for I very much

desired a closer acquaintance with this wonderful old fox, who had matched his wit against that of man and the trained hound. The fox evidently had a similar inclination, for he slowly raised himself, standing at full height for a moment, and then advanced probably fifty feet. Here he stopped an instant as if to reassure himself that he had made no mistake, and then trotted toward me, a little to one side of a direct line, and came to rest on a knoll above me, about six rods away. Thus he stood for fully a minute, keeping his eyes fixed on mine, and then, turning suddenly, he disappeared among the brakes. Before this I had known the fox only as a shy and cunning animal, but this one had shown another side. My attitude of friendliness toward him seemed to be reciprocated, and I believe that with me he had lost the fear that was so evident in his relations with other men.

I was now certain that his den and family could not be far away, so the next morning I led the dog to the place where I had met the fox on the day previous. Almost before I had time to remove the dog's collar, the fox appeared, not a hundred feet away. In a moment the dog had sighted him, and away they went to the south over the old course. I now devoted my time to a search for the den, and within twenty minutes stumbled upon it. It was strange that I had not found it before, as I had been within a few feet of it several times.

During the afternoon I laid plans for the further study of the old fox. The following morning I led the dog to the former place of starting. The fox appeared just as on the previous day, and away they ran over the course of the



A GOOD "FIND."

morning before. With field-glass in hand, I followed until I reached a point on the side of the ravine opposite the den, from which I com-



WATCHING THE HOUND IN THE VALLEY BELOW.

manded a full view of the valley below, as well as of the den. Here I concealed myself and awaited further developments.

The sound of the hound's baying died away in the distance, and for about an hour the stillness was broken only by the occasional song of birds and the chirp of insects. Then again I heard the hound, and in a little while he appeared in sight in the valley below. He apparently had lost the trail, and so it proved, for in another half-hour he passed my place of concealment on the way to the house. I watched until the middle of the afternoon, but saw nothing more of the old fox.

The next day I repeated the experiment, and watched particularly for the appearance of the dog in the valley. I found that he lost the trail in about the same place near the creek. Sometime before this I had seen the fox coming up the creek near the den, which he passed, never so much as turning his head, and I soon lost sight of him among the ferns and low bushes.

The dog worked the trail for some time longer, but finally gave it up and went to the house. By this time I thoroughly understood the action of the dog. Now I must watch for the fox. On the third day, as the fox and the dog started as before, I carefully watched the place where the dog had lost the trail. Two hours later I saw the fox, on his return trip, on the top of a stone wall, at the place where the hound lost the trail each time. The wall at this point was so near the creek that the fox could jump from the wall to the bed of the creek. The banks were low for some distance, and I could see him in the shallow water, making his way toward the den. As the banks became higher he was lost to view, and I turned the glass upon the creek, which was fully exposed near the den. In a little while he passed this point, and farther up the creek came out upon the high ground and seated himself near a stump, carefully sur-



"THESE SEEMED TO FOLLOW THE FOX."

veying the valley below. At first he seemed very calm, but became more restless as the hound appeared in the valley. By the time the dog had reached the place where the fox had taken to the wall, the fox, in his apparent delight,

lost all control of himself. He jumped and frisked about, and seemed to enjoy the perplexities of the dog with almost human intelligence. As the dog became more and more bewildered,



THE STONE WALL USED BY THE FOX IN ESCAPING FROM THE HOUND.

he gave vent to his disappointment at intervals in long-drawn howls. These seemed to electrify the fox, his hair bristled, and for a moment he looked very fierce; but almost instantly a change came over him, he lay down, opened his mouth, and fairly laughed as the dog became more and more puzzled. These varied scenes lasted for half an hour, until the hound uttered one prolonged howl and gave up the struggle.

Thereupon the fox became quiet, resting in a position half concealed by a stump, where he could watch every movement of the dog. After the dog had passed, the fox sat up on his haunches and watched him until he was out of sight, when, almost instantly, the fox turned and disappeared among the low bushes which skirted the maple grove.

This performance was repeated almost to the letter on the following day. The situation was now perfectly clear to me. The fox was on guard at the head of the valley, ready to lead the dog away, and, after completely fooling him, returned by way of the creek, and from his

vantage-point at the upper end of the valley in the stump-lot watched with absorbing interest the perplexities of the old hound.

It was now time to attempt to photograph the fox; his acquaintance had been carefully cultivated, his method of deceiving the old hound studied, and his appetite satisfied with many a fat chicken. Knowing something of his resting-places at the head of the ravine, where he watched the hound in the valley below, and being supplied with a long-focus lens and a release to the shutter that could be operated from two to three hundred feet distance, I felt reasonably sure of success. The camera was properly concealed, and after about two weeks of con-

stant work there were found among the numerous failures four fairly good negatives.

I saw nothing of the fox during the week which ended my stay at the farm. At night I sadly missed the barking that sounded from the grove or meadow, and sometimes even closer to my window; but I had a secret hope that the tamest of wild foxes was still active and — even, alack! at the expense of chickens and goslings — might long outwit those who sought his life.





HOW SOME FLOWERS GOT THEIR NAMES.

By E. B. H.

THE origin of the names of flowers is an interesting study. Have you ever wondered how they got their names—their every-day, simple names by which we call them?

We all know how people get their first names. Uncles and aunts, brothers and sisters,

and cousins, perhaps, all have their suggestions to make, and finally the father and mother decide what the baby shall be called. The name may be chosen because it belongs to some one else, or just because it is pretty. It has nothing to do with the appearance or character of the baby. Blanche, Lily, and Pearl may be brunettes, and Philip may prefer an automobile to a horse, but they still keep the same names, though they do not suit them at all. I

do not think that the flowers were named until after they were quite grown up, so that such mistakes have been avoided with them. Their names in some cases, however, have been changed from their original forms, and it is often hard and sometimes impossible to find the reason for our calling them as we do.

Some flowers, however, are named after the men who discovered them, or after famous botanists. Among these we have the gardenia, the fuchsia, the dahlia, the wistaria, and the camellia, after Garden, Fuchs, Dahl, Wistar, and Kamel. So





remember that,
and you will not mis-
spell fuchsia, nor mis-
pronounce wistaria and
camellia.

It is easy to see why
some flowers are named
as they are, for it
does not seem as
if the buttercup
or the bluebell
could have been
called anything else.
But there are not many
flowers the meaning
of whose names is as
easily guessed as those,
though there are a
number which get
their names from the
appearance of the
blossom, leaves, or
seed-pods.

Who could guess
that the dandelion
was the "dent-de-lion"



THE SONG OF THE MORNING GLORY.



"PANSIES"

"FOR
"PANSIES"



or lion's tooth; the tulip so called because it looks like a turban, and tulip was another name for turban?

The beautiful gladiolus is a sword-lily: "gladiolus" in Latin means "a little sword." It is so called from the shape of its leaves. The asphodel is from the Greek word meaning "king's-spear." The name daffodil comes from "asphodel," and so means the same thing.

Some country people will tell you that a cowslip is so called because the cows will not eat it; others think it means "cow's lip"; but the explanation accepted as the true one is that the color of the flower suggests bits of butter that the cow has scattered around her path.

The columbine, geranium, and larkspur we think of together because they are all named after birds—the dove, the crane, and the lark. The meaning of geranium is "crane's-bill," and if you notice the seed-pods of a geranium you will see that they do look like the long bill of a crane. The touch-me-not gets its name from a peculiarity of the seed-pod, too,

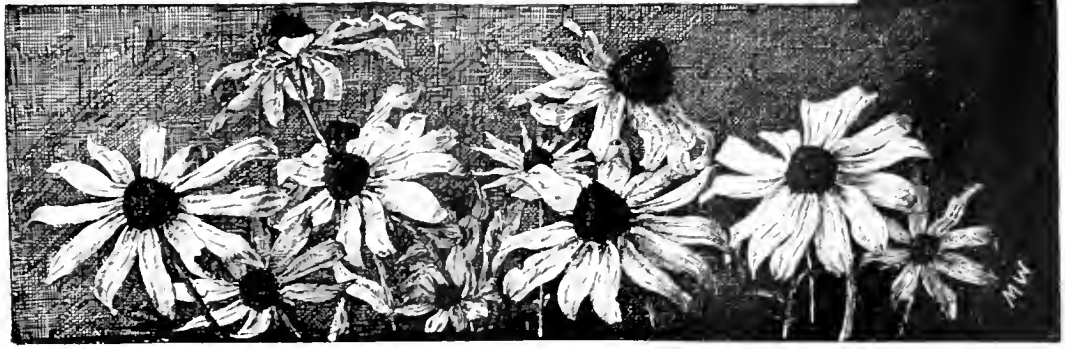



"DAISY."

but not a peculiarity of appearance. It is the pool you must not touch, for if you do it will burst and out will fly the seeds.

The lupine gets its name from a Latin word, *lupus*, meaning wolf. Some think the plant was

thus named because it is very greedy and takes so much nourishment from the soil around it.

The lycopodium owes its name to the wolf, too; it means "wolf's-foot," and is intended to describe the appearance of the roots.

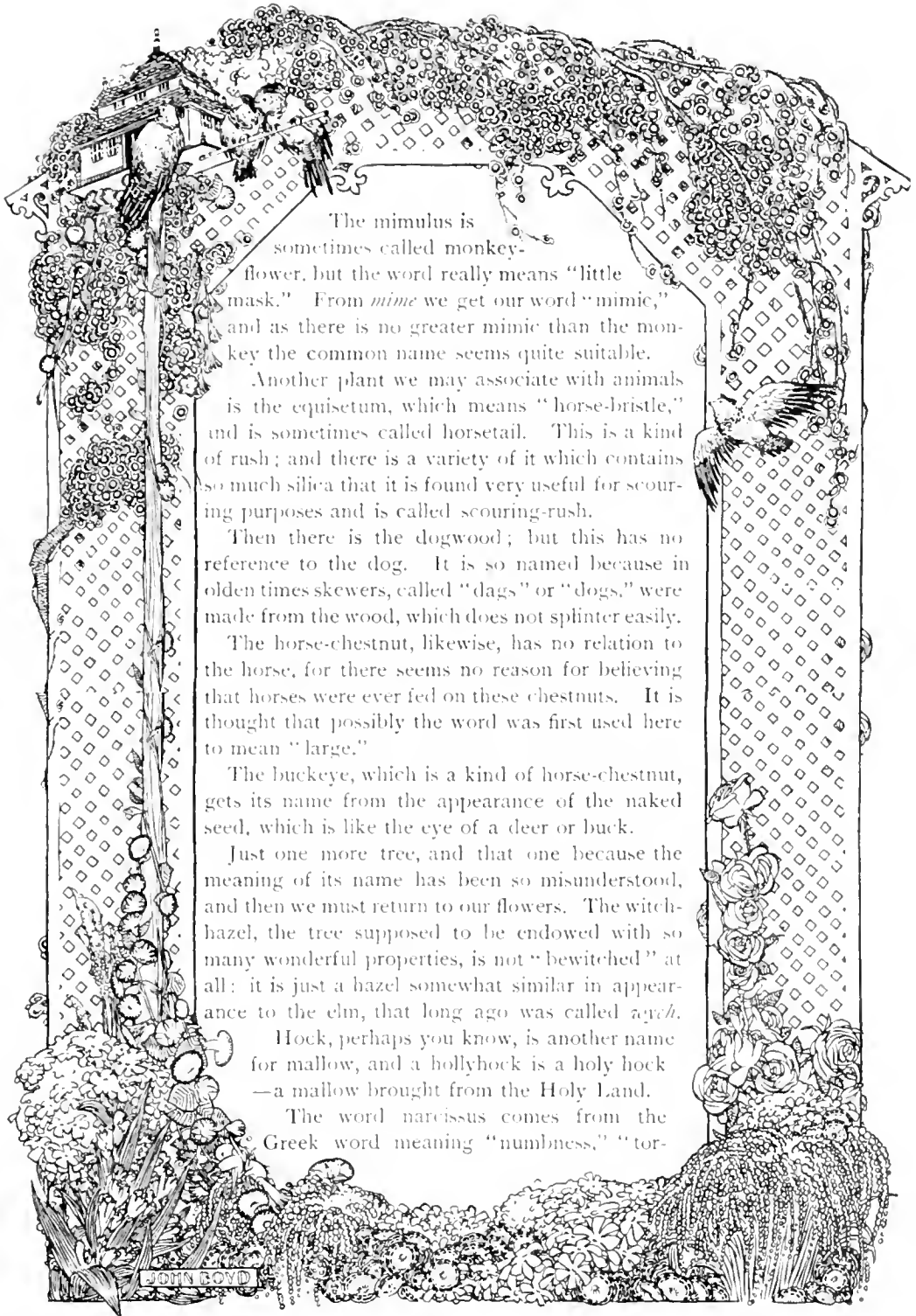

The mimulus is sometimes called monkey-flower, but the word really means "little mask." From *mime* we get our word "mimic," and as there is no greater mimic than the monkey the common name seems quite suitable.

Another plant we may associate with animals is the equisetum, which means "horse-bristle," and is sometimes called horsetail. This is a kind of rush; and there is a variety of it which contains so much silica that it is found very useful for scouring purposes and is called scouring-rush.

Then there is the dogwood; but this has no reference to the dog. It is so named because in olden times skewers, called "dags" or "dogs," were made from the wood, which does not splinter easily.

The horse-chestnut, likewise, has no relation to the horse, for there seems no reason for believing that horses were ever fed on these chestnuts. It is thought that possibly the word was first used here to mean "large."

The buckeye, which is a kind of horse-chestnut, gets its name from the appearance of the naked seed, which is like the eye of a deer or buck.

Just one more tree, and that one because the meaning of its name has been so misunderstood, and then we must return to our flowers. The witch-hazel, the tree supposed to be endowed with so many wonderful properties, is not "bewitched" at all: it is just a hazel somewhat similar in appearance to the elm, that long ago was called *aych*.

Hock, perhaps you know, is another name for mallow, and a hollyhock is a holy hock—a mallow brought from the Holy Land.

The word narcissus comes from the Greek word meaning "numbness," "tor-



"MYRIADS OF DAISIES HAVE SHOWN FORTH IN FLOWER."

por," and the plant has that name because of its narcotic or sleep-giving qualities.

The jonquil is of the same genus as the narcissus but is not named in the same way. Like the asphodel and the gladiolus, its name comes from the shape of the leaf. It has rush-like leaves, and "jonquil" comes from *juncus*—a rush.

Heliotrope means literally "sun-turn," and is

the Greek word for sun-dial. The flower of that name needs a great deal of warmth and is said to turn toward the sun, just as the sunflower is supposed to do. The heliotrope is sometimes called turnsol, which means just ex-



"HERE BESIDE THE MODERN STOCK
FLAUNTS THE FLOWERING HOLLYHOCK."



IN THE SUNFLOWER GARDEN.

actly the same as heliotrope, and is a name also given to the sunflower. The wind, too, has a flower named for it—the anemone.

Shakspeare makes *Ophelia* say, "There 's rosemary, that 's for remembrance: there is pansies, that 's for thoughts." Did you ever realize that pansies really are "for thoughts"? The French word *pensée* means "thought."



I do not know why rosemary should be for remembrance. It is not a kind of rose, as you might be led to believe. Its name comes from the Latin words *ros* and *marinus* and means "sea-dew."

And the daisy, it has always seemed to me, has the prettiest name of all—the day's eye. Wide open when the sun shines, it dozes when night comes and its duties are ended; for the night has other eyes all her own, as we find in the beautiful aster.

when it was still a single flower like the daisy, and some wild asters are still called daisies. And



The aster I have left to the last—it comes from *astra*, the stars. It probably was named

are their names so very different? One is the day's eye, the other the star—the eye of night.





A GENUINE VIRGINIA CREEPER.

A LITTLE STORY OF TWO LITTLE GIRLS.

BY STELLA GEORGE STERN.

ALICE and Bertha played in the same garden, because they were little sisters.

They were always playing in the garden, and everybody who passed by would say, "Hello, Alice!" and "Hello, Bertha!" and the little sisters would run to the fence and say, "Good morning! Good morning!"

But one day a very sad thing happened. Alice and Bertha had a quarrel.

Alice wanted to play that her house was under the pink rose-bush by the fountain. But Bertha wanted to play that her house was under the pink rose-bush by the fountain. So Alice said that she would n't play at all. And Bertha said neither would she. They each walked around the garden alone. It was sad.

They thought the sun did not seem bright, and they thought the flowers were not pretty, and they did not like the little fountain, and

they were very miserable and did not know what to do.

So Alice walked back to see what Bertha was doing. And what do you suppose that was?

Why, Bertha was walking back to see what Alice was doing.

Just then a little bird flew down and took a bath in the fountain. He splashed and splashed and splashed. Alice clapped her hands and laughed. And Bertha did too.

Alice and Bertha looked at each other and kept right on laughing and laughing.

"You may have your house by the pink rose-bush, Bertha," said Alice.

"Oh, no! You have yours there," said Bertha.

"I tell you what," Alice said. "We will have our house there together."

The dreadful quarrel was over at last, and the two little sisters were happy again.

PINKEY PERKINS: JUST A BOY.

BY CAPTAIN HAROLD HAMMOND, U. S. A.

V. HOW PINKEY CLOSED THE SCHOOL TERM.

PINKEY PERKINS and his schoolmates were building their towering castles of things to be done as soon as vacation time should come.

Every morning, when Red Feather asked if there was any preference in regard to the opening song, the request was always the same: "Vacation Time is Coming—the Happiest of the Year." To the pupils there seemed to be something delightful in the words of their favorite song, and it was with a will that they all joined in singing it, and especially the rousing chorus:

"Come lay aside your labors, and drive all care away;
We've had our time of study, and now 't is time for play.
We'll fill the lovely summer with joy and pleasures dear;
Vacation time is coming—the happiest of the year."

There were plans on foot for a grand celebration on the last day of school, which, though it seemed ages distant, was but two weeks off.

In addition to the usual speeches and essays, there was to be a dialogue on that occasion, and Pinkey was not in the best of humor over the part given him. Red Feather had seen fit to assign to him a minor rôle, while Putty Black had been named to take the part which made him an escort for Hattie Warren, Pinkey's Affinity, in the numerous trips back and forth across the platform which was to do duty as a stage.

After his oration at the church on Children's Day, Pinkey had resolved, once and for all, that he had made his last appearance as a public speaker; but, in spite of that resolution, here he was, less than two weeks afterward, rehearsing his part in a dialogue. That Welcome Address was still a very sore subject with Pinkey. He never mentioned it to any one, and stood ready and willing to do his best to punish any one who mentioned it to him.

One Monday morning, about three weeks

after Children's Day, Pinkey and Putty became involved in a wordy war over a game of leap-frog. Pinkey claimed that just as he went to jump Putty had "let down," thereby sending Pinkey sprawling in a muddy place in the yard. In his fall he had carried Putty down with him, and both were much the worse for their tumble. This disagreement soon assumed a most threatening aspect, and, to make matters worse, Putty unwisely suggested that Pinkey could probably jump better if he only had on his mother's overshoes.

At the mention of "overshoes," and especially coming as it did from Putty, Pinkey became fighting mad in an instant.

"Don't you say 'overshoes' to me," said Pinkey, bristling up to Putty sidewise. "I've just been wanting a chance to settle with you ever since that Sunday when you laughed at me and whispered to Bess Knapp about my overshoes."

A crowd began to gather, and then it was too late to back down, if either had thought of doing so.

"Stand back and give 'em elbow-room," shouted one of the interested spectators. Sufficient space was cleared, but still the two boys only stood and glared at each other.

There was a sudden scattering of the crowd, followed by the appearance on the scene of Red Feather, bareheaded and severe, and armed with the ever-present hard-wood ruler.

This put a stop to all prospects of a fight, and, before either Pinkey or his foe could escape, Red Feather had taken each of them by the coat-collar, in a vise-like grip, and was marching them off to the school-house. Once or twice Pinkey had settled back against the power that was silently urging him onward, but each time a vigorous shake of the propelling hand reminded him how useless his objection was.

"What were you boys fighting about?" questioned Red Feather, when she had safely landed her charges in the school-house.

"Were n't fightin'," said Pinkey.

"Well, you were going to, which is as bad. What is the matter, Harry?" Putty was borne on the rolls as "Harry."

Putty began to snuffle, as he had a habit of doing when he got into trouble.

"Pinkey Perkins picked a fight with me 'cause he said I laughed at him in church one time," replied Putty.

"You did laugh at me, too —"

"That will do, Pinkerton," interposed Red Feather; "it is enough you were quarreling, and



"BOTH WERE MUCH THE WORSE FOR THEIR TUMBLE."

you both know that quarreling as well as fighting is against the rules. There can be no excuse for such disobedience."

"Well, what 's a feller to do when —"

"Pinkerton!"

"If I can't p'tect myself against a feller who laughs at me when I 'm makin' an address —" continued Pinkey, regardless of Red Feather's warning.

"Pinkerton, be careful," cautioned Red Feather, giving him another shake; "remember to whom you are talking, and what you are saying."

Pinkey was apt to be rash in his statements at times, and to say things of which he afterward repented.

As a punishment for quarreling, Red Feather condemned Pinkey and Putty to brush the dirt from each other's clothes, and, for being impertinent, to occupy the same seat the remainder of the forenoon.

As the pupils entered the room after recess, there was Putty down on his knees, whisk-broom in hand, brushing away at the dirt stains on Pinkey's clothing, while the latter stood with his hands behind him, solemnly regarding the transom over the door.

When Putty had finished, Red Feather bade him arise and transfer to Pinkey the whisk-broom. When he offered it to Pinkey, the latter did not move his hands from their position behind his back.

"Pinkerton," said Red Feather, "take the whisk-broom and brush off Harry's clothes."

Pinkey shook his head.

"Do you hear me? Now don't make it necessary for me to speak again."

Still no reply from Pinkey, either by word or movement.

"Pinkerton, are you going to do as I bid you, or shall I be obliged to chastise you?"

Pinkey still declined to move, though he knew what his stubbornness would bring him.

With grim courage he accepted the whipping he had chosen, receiving the punishment on the palms of his hands through the medium of a hard-wood ruler. When it was all over he marched proudly to his seat, with joy in his heart sufficient to offset the burning of his hands. He had stuck to his inward resolve not to clean off Putty's clothes, and Red Feather had been unable to make him cry when she whipped him.

Nothing was said about Pinkey and Putty sitting together, and Pinkey was allowed to retain his own seat. As soon as Putty, with the assistance of Red Feather, had cleaned his muddy clothing, he returned to his seat. He had got off easier than Pinkey, but he knew that by doing what Pinkey would not he had lost standing with his fellow-pupils.

Affairs at school now settled back to their usual state. But Pinkey had not forgotten his

grievance about the dialogue; and although he attended rehearsals regularly, he grew more and more disgusted every time he saw Putty escort Hattie Warren across the platform.

Before long, his heart was set on stopping the whole dialogue, and, if possible, doing it in such a way that he would not suffer for it later.

After considering and passing as inadvisable or impossible a number of schemes, Pinkey at last hit upon one which he hoped might succeed.

In the school-room were two old-fashioned coal-stoves, each having a long line of stove-pipe running overhead to the one central chimney of the building. Since they had ceased to be of need, they had been used as receptacles for all waste paper and odds and ends that had accumulated, until both were full to bursting.

It was upon these stoves and their contents that Pinkey depended to make his scheme a success.

In Bunny Morris he found a willing assistant who, in this case, was even more ready than usual to do his part.

Bunny was down on the program for an essay entitled, "Why I Love My School Work"; and, needless to say, he was not at all in sympathy with his theme.

When school convened that last afternoon, everything was in readiness for carrying out the lengthy program Red Feather had prepared. All books, slates, and other school material had been taken home at noon, and nothing remained to mar the success of the occasion or to suggest the long and tedious term now so nearly completed.

Visitors came in goodly numbers, and the pupils whose seats were near the front of the room received instructions to sit elsewhere, the guests being assigned to these seats.

Pinkey's mother came, which fact did not fill Pinkey with the proper delight, and he envied Bunny, who had no relatives present.

Red Feather, her little dangling curls showing unusual and careful attention, was faultlessly arrayed in her best black alpaca. She busied herself in seeing to the comfort of her guests, and in bestowing here and there frequent and unexpected caresses on her assembling pupils.

One of the guests was a member of the

School Board, and in addition there were others present who had sufficient influence to work either benefit or harm to Red Feather at the coming meeting of the board, when teachers would be selected and salaries fixed for the coming year.

All the children were decked out in their Sunday best, and the room assumed an air quite in keeping with the spirit of the occasion.

The school bell tolled its last commands for many weeks to come, and pupils and guests arranged themselves about the room as directed. Pinkey and Bunny, who usually sat in the front row and on opposite sides of the room, selected seats in the back part of the room, convenient for the carrying out of their plan.

"Vacation Time is Coming" was given a last rousing good-by, with a repetition of the chorus as an encore. Then the member of the School Board, at Red Feather's request, made a long, rambling address.

First on the regular program was a very parrot-like attempt at a recitation of "Thanatopsis," by a little girl perhaps eleven years old. She became confused, then frightened; and, finally, her memory failing her altogether, she broke down completely and took her seat amid a flood of tears which even the soothing caresses of Red Feather could not stop.

The next number on the program was an essay by Eddie Lewis, entitled, "Honesty — The Best Policy." At the conclusion of this paper, those who were to take part in the dialogue were to assemble on the platform and make their preparations behind the large calico curtain which was to do duty as a theater curtain by being drawn to and fro as occasion demanded. After what seemed to Pinkey and Bunny a very long time, Eddie concluded with a stiff, hinge-like bow, and with the bow came a loud, approving volley of hand-clapping, during which all eyes were fixed on Eddie.

Pinkey gave Bunny the signal. It was time to act, and to act quickly. While the noise was at its loudest, and without attracting the slightest attention, they lighted the matches they had been holding in readiness. Bunny was quite close to one of the stoves, and it was an easy matter for him to reach out and touch his match to the piece of carefully arranged paper pro-

truding from the stove door. Then he quietly arose and took a different seat, as he had done twice since the exercises began. As the applause subsided, he was gazing blandly out of the half-open window, with an expression of the most angelic innocence on his face.



"THERE WAS PUTTY DOWN ON HIS KNEES, BRUSHING AWAY AT THE DIRT-STAINS ON PINKEY'S CLOTHING."

Pinkey, as soon as he struck his match, arose from his seat and started for the platform, carefully shielding from view the burning match in the concavity of his hand. As he passed the desks on his side of the room and reached the stove, he paused for an instant, ostensibly to pick up the handkerchief he had dropped, but really to ignite the paper in the bottom part of the stove.

Then he walked on up the aisle and disappeared behind the large calico curtain.

As the fire in the stoves gathered headway, the smoke began to pour into the room from the openings in the doors and from every crack and joint. Red Feather and those seated in the front part of the room heard a commotion

among the pupils, and on looking around were dumfounded at what they saw. Red Feather at once arose, much excited, and tried to think of something to do or say; but, for once in her life, speech forsook her.

Once started, the smoke was rolling from every outlet in the stoves as from two miniature volcanoes. The stoves being full and the dampers carefully closed, the contents could not blaze freely, but the volume of smoke which poured into the room increased momentarily.

Red Feather ran to one of the stoves and opened the door, but that only permitted more of the pent-up smoke to rush out into her face and bring tears to her eyes.

"Who started these fires?" she shouted as she shut the door again. "Speak up. Who lit this paper?" But she received no response to her demands.

As the smoke grew thicker and began to spread in obscuring skeins throughout the room, the fumes of smoldering wool and leather smote the nostrils of those near the stoves. Pinkey had thoughtfully placed some old rags and an old shoe in each stove to aid the smoke in its purpose. Some one opened the hall door, hoping the smoke might blow out; but there was not the faintest breeze stirring, and the attempt at ventilation was fruitless. Several of the pupils began to cough, and those who had not done so in the beginning left their seats and retreated toward the platform, where the visitors were gathered. Bunny, with no parental eye to check him, escaped into the hall and out into the yard. Vacation for him had begun at last.

Pinkey remained behind the curtain, not desiring to be questioned by his mother.

Finally the member of the School Board, acting as self-appointed regulator of the disturbance, said to the much-worried Red Feather: "Just calm yourself, Miss Vance. Leave everything to me. I will extinguish the fires and endeavor to rid the room of smoke." He was as much at loss as to how he was going to accomplish his task as any one else.

Boldly he marched through the thickening maze, coughing and wiping his eyes. On reaching the stove, he saw that the only thing to do was to open the dampers and let the fire burn

itself out. After burning his fingers in closing the damper in the door, he noticed that the damper in the pipe also needed adjusting, and mounted one of the desks in order to reach the pipe.

Just as his tall, lean figure loomed up above the lowering clouds of smoke, Bunny Morris came rushing madly in the door, shouting in genuine panic-stricken tones: "There 's powder in that stove! It 'll bust in a minute!"

After leaving the school-house he had suddenly remembered that this was the first time there had been a fire in the stoves since April Fool Day, when Pinkey had told him that he knew some one had hidden a can of powder in the stove, because he had seen it there. In reality, Pinkey himself had placed a small can of baking-powder in one of the stoves, and had told Bunny of the "powder," hoping to "fool" him.

But Bunny had been too wary to investigate any rumors that day, so Pinkey had later returned the can to the pantry at home; and during the weeks that followed nothing more had been said or thought about powder.

So it was that Bunny's alarm was decidedly real as he tore breathlessly into the room to warn the occupants against the explosion of what he really believed to be gunpowder.

In the stampede which followed, the member of the School Board cleared at one leap the row of desks between him and the outside aisle, and joined in the frantic retreat from the room. A dozen throats took up the cry, "The stoves 'll blow up! The stoves 'll blow up!" repeating it in their scramble for safety.

Ferried mothers embraced their daughters and carried them from the room to the yard. With the exception of the member of the School Board, who escaped early in the excitement, the few men present devoted their efforts to quieting the frightened ones. It was plain to

them that had there been powder in the stoves, they would certainly have known of its presence long before this; but no words of theirs could stop the frantic rush for the doors.

For a few moments, Pinkey was more frightened at the result of his joke than was any one else. He had visions of an awful explosion, and his heart sank within him as he thought of the consequences. But when he remembered the baking-powder, the cause of Bunny's alarm was evident, and he felt a wave of relief come over him as the terrible possibilities vanished. His presence of mind returned, and he viewed with the utmost pride the outcome of his scheme, the great success of which was due to Bunny's needless heroism.

On all sides Pinkey heard glowing words of praise for Bunny's bravery, and now he saw a chance to distinguish *himself*. Rushing into



"HE GREW MORE AND MORE DISGUSTED EVERY TIME HE SAW PULLY ESCAPE BATTLE WARREN ACROSS THE PLATFORM"

the hall, he secured the two buckets of drinking-water that were there and which, in the excitement, had been entirely forgotten. With great effort, and consequent damage to the clothing of those who jostled him, he reentered the room, and going first to one stove and then

to the other, dashed a bucketful into each, completely extinguishing the fires.

He, too, could be a hero.

As the last of the occupants were leaving the smoke-filled room, teachers from the adjoining rooms ran excitedly into the hall to see what could be the cause of such unusual noise and

It was a rather shamefaced crowd that gathered in the yard, after it was all over, to discuss the excitement before dispersing. Some of the more timid were still unconvinced that danger was past, and thought that the entire school should be dismissed; but wise counsel prevailed and overruled their proposition.

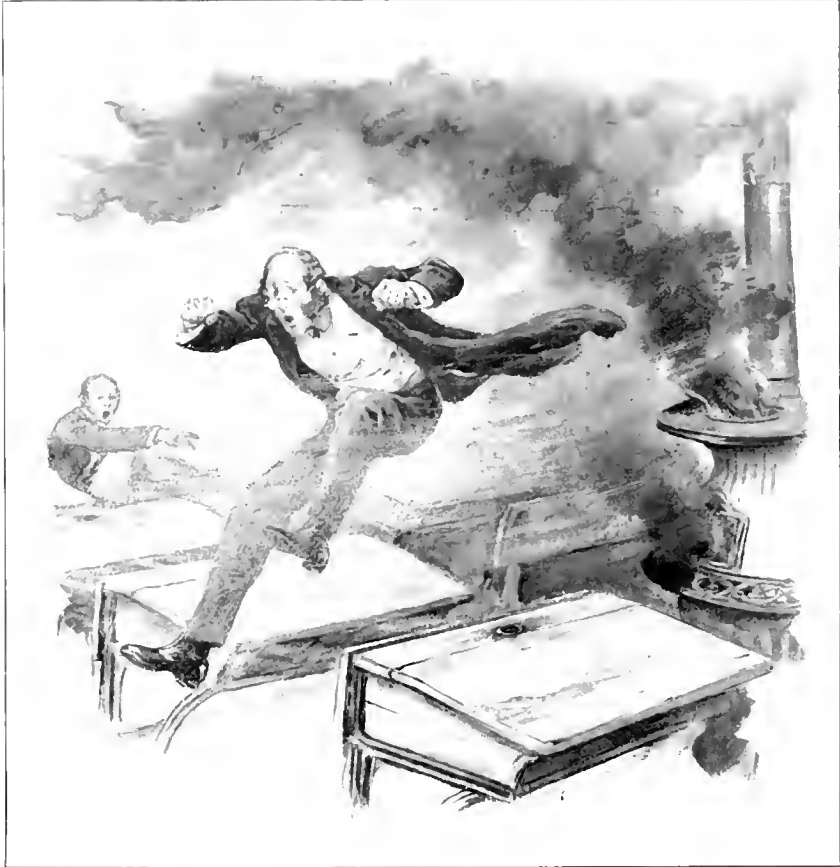

"IN THE STAMPEDE WHICH FOLLOWED, THE MEMBER OF THE SCHOOL BOARD CLEARED AT ONE LEAP THE ROW OF DESKS BETWEEN HIM AND THE OUTSIDE AISLE."

confusion; and had it not been for the cooler heads, who explained the whole matter and assured them that it would be foolish to do so, every room in the building would have been dismissed. But when convinced that there was no danger of an explosion, they returned to their classes, entirely reassured; and, with the exception of Red Feather's room, which was still filled with smoke and the odor of wet, charred paper, the exercises were continued.

Pinkey, realizing how necessary it was to his present glory and future welfare that the rumor of powder in the stove should not be investigated, managed to get near to Bunny before the latter had been questioned. Without going into any details or explanation, he said to Bunny, in an undertone that conveyed volumes to that young man's mind: "Now — you — skip! School's out for this year."

And Bunny took the hint.



A JUNE EVENING ON THE BROOKLYN BRIDGE.

A FROLICSOME PLAYFELLOW.

BY GEORGE BANCROFT GRIFFITH.

A PLAYFUL little wind was out,
A roving, baby breeze, you know,
Not boisterous,—like the boys who shout
When school is done, and homeward go,—
Yet full of fun and mischief, too.

There, at the entrance to the wood,
He shook the trees till rain-pearls flew
As from a fount in merriest mood!
Then running through the fragrant grass,
He found a window opened wide,
Where Elsie sat, the studious lass,
With notes and drawings by her side.
Whiff! How the rustling papers spread!
This fresh, sweet, unseen presence there

Put new thoughts in that curly head
While morning lessons claimed her care.

And next, all unabashed, within
The library's open door he stole,
Where grandpa sat, with features thin,
An innocent and drowsy soul!
He softly stirred his silv'ry hair,
And fanned his faded cheek in glee,
Just touched his dear hand white and fair,
And brushed the book-mark from his knee.
Then noiselessly he sped away,
This baby breeze that none could hold,
To come again some sultry day.
A welcome guest with gifts untold!



“ BISMARCK.”

This dignified Great Dane was named “ Bismarck,” for he was a great-grandson of Tyras, who lost his life while dragging furniture from the burning palace of his master, the great German chancellor. Bismarck had not the fierce look usual with Great Danes, because his ears were as nature made them and had not been trimmed in the cruel fashion of the day.

Sometimes puppies presumed on his gentleness and teased him without harm, but if a dog of size became troublesome a big paw was laid upon that dog and he was crushed to the earth.



“HE RARELY ALLOWED HER TO PASS THE GATE WITHOUT HIM.”



“HE WAS ALWAYS READY FOR A ROMP WITH HIS FRIEND.”

Bismarck once adopted a little spaniel with a big name and was bullied by him without limit. “ Kaiser Wilhelm ” was a restless puppy who got into disputes with

strange dogs, and then Bismarck stood between Kaiser and trouble; and Kaiser, being only a dog, repaid him with gratitude and danced around him in token of affection. Together they caught woodchucks and chased minks, squirrels, foxes, and an occasional bear. Once they caught a porcupine, and Bismarck came home with a full growth of porcupine-quill whiskers.

Bismarck's chosen friend was the bicycle-girl, whom he rarely allowed to pass the gate without him. As she rode through woods and

over lonely roads he was always beside her wheel, and was ever ready for a romp with his friend. He would jump around her in a fashion so lively that a stranger usually sought safety by climbing the nearest fence.

At night, from the hearth, Bismarck's eyes would turn with kindly gleam from one to another of those he was guarding.

A melancholy interest is added to the story by the fact that about a year ago Bismarck perished in the flames which destroyed his master's house, as did his ancestor Tyras.

A. W. Dimock.

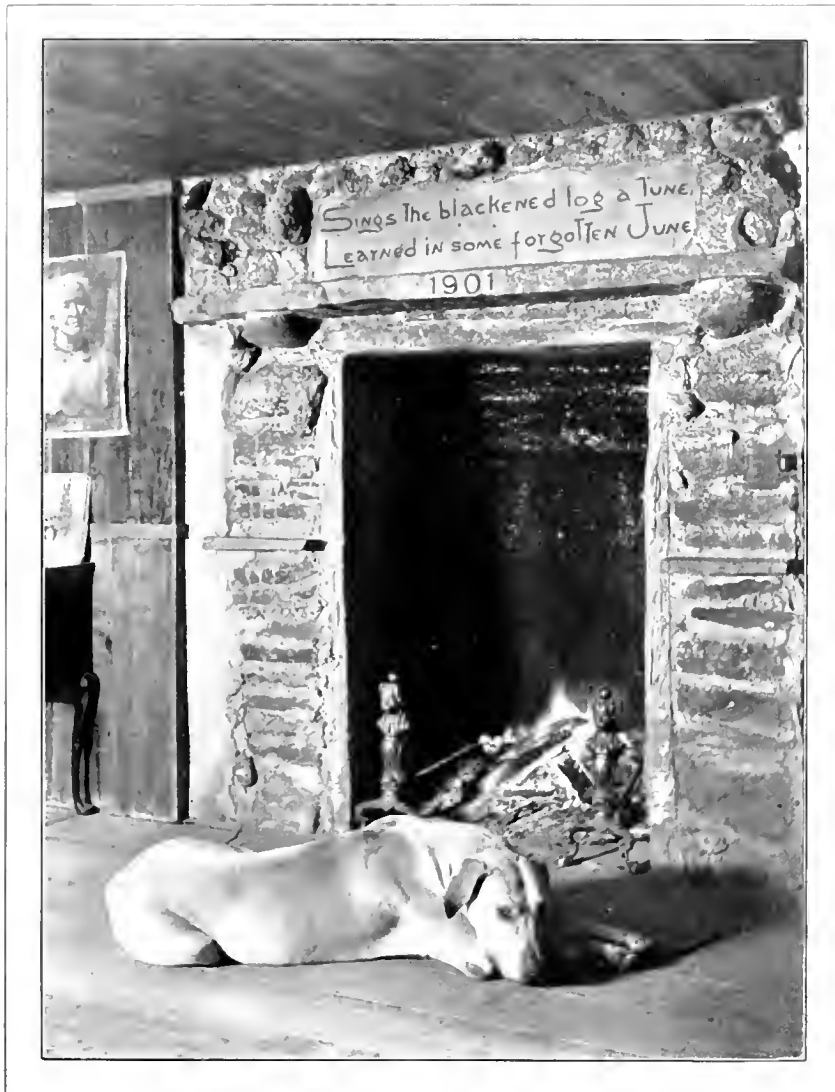

"POLLY PORTER."

BY MARY RICE MILLER.



PERHAPS all parrots have equally remarkable memories; but twenty-five years' acquaintance with "Polly Porter" enables me to say that he never forgets what he has once learned. Like other parrots, when he is alone he exercises his memory, as if amusing himself. Then it is that Polly Porter chatters in sentences; laughs aloud, hysterically; calls, in various tones, commandingly or beseechingly; calls the names of servants who, but for Polly,

would have been forgotten; calls the cat; whistles for dogs who were about him years ago.

Polly's cage is in the bow-window of the dining-room — a good place for keeping an eye on the family. When the father rises from the breakfast-table Polly advises: "Hurry! Hurry up! Hurry!"

Later, with the first movement preparatory to the children's start for school, he repeats sharply: "Hurry! Hurry up! Hurry!"

When a guest comes in he says briskly: "Why, how d' ye do?"

When he calls "Good-by" to persons passing on the street it seems almost certain that he reasons about the coming and departing guest. He quickly notices little children: coming to one particular corner of the bottom of his cage, he flutters before a little one, attempting baby-talk, which is very funny, ending with, "Beautiful child! Beautiful child!" and a loud laugh.

When the house is quiet and his mistress has a visitor in the parlor, Polly craves attention.

He repeats the children's names, almost as if he were calling the roll, in sweet, low tones. Then he says "Ma-ma!" over and over, in a child's voice, till it is common for a visitor to say, "Do answer that child," or "Some one is

calling you." He comes very near to telling tales, saying, "Ah, ah! naughty boy!" with great severity.

Polly is most impatient at breakfast-time, when he shrieks till he receives attention: "Polly wants coffee! Polly wants breakfast!"

He takes a piece of bread cautiously; examines it; if it is not well buttered he throws it down. He enjoys a bunch of grapes, holding it down with one claw while with the other and

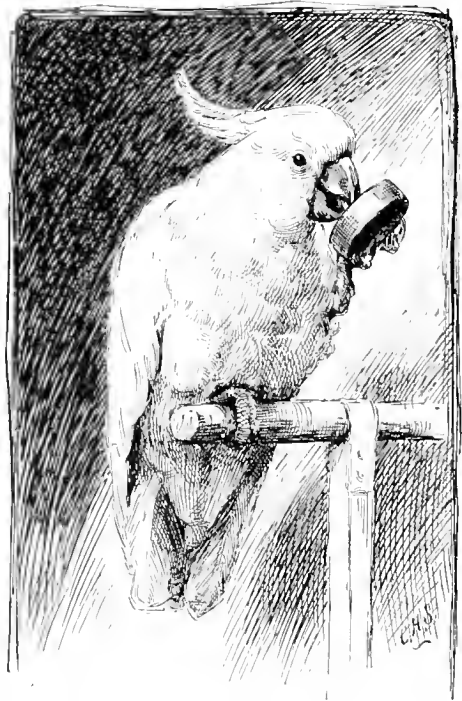

"POLLY PORTER."

his beak he opens grape after grape, eats the seed, and casts the pulp away. He easily crushes a pear or an apple to get at the seeds.

Last Christmas Polly was sent by his owner, a New York boy, to friends as a present. They were told of his liveliness and astonishing powers of speech.

For some months Polly moped and said no-

thing, but at last began calling members of the family by name. If let out of his cage, he fought the pug and whipped the cat; when shut up in his cage for punishment, he would persistently work at the wires till he would force them apart and walk out defiantly. Recently

he began upon his old lessons, and now repeats the cries of the newsboys in the street: "Extra! Extra! Journal!—Sun!—Herald!" And he sings quite well "Yankee Doodle," which was taught him last summer.

Good-by, Polly!

JOHNNY AND THE PARROT.



JOHNNY was a little boy, and they were trying to teach him to talk.

Polly was a little parrot, and they were trying to teach *him* to talk.

Polly belonged to Uncle Tom, and Uncle Tom was proud of him.

But Johnny belonged to mama and papa, and you may be sure they were very, very, very proud of *him*.

"Oh," Uncle Tom used to say, "you wait and see. My parrot will talk before your baby will."

But "Oh," mama and papa would then say, "*you* wait and see. Johnny will talk before your parrot will." And they waited.

But all Polly said was, "Craw, crawl, crawl!" And all Johnny said was, "A-zoo, a-zoo, a-zoo!"

One day Uncle Tom went to Polly's cage.

"Polly," he said, "say 'Pretty Polly!'"

And what do you think?

Polly did! He said, "Pretty Polly!"

Uncle Tom ran to mama and told her what Polly said.

"Oh, ho!" said mama, "Johnny has been talking all the morning."

But Johnny did not say, "Pretty Polly!" Johnny said, "Ma-ma," over and over again.

Now Johnny has grown to be a big boy; he can say a great many things. But Polly can say only, "Pretty Polly!"

S. G. S.

THE TWINS.

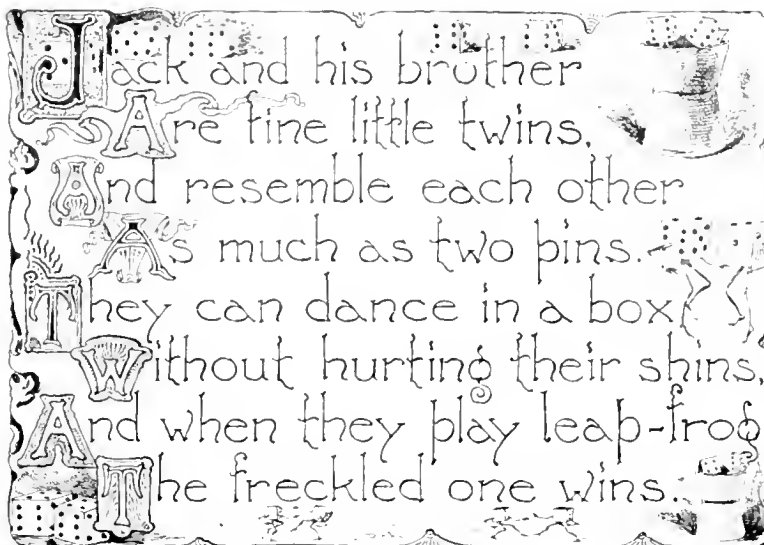

NATURE AND SCIENCE FOR YOUNG FOLKS.

EDITED BY EDWARD FB GELOW

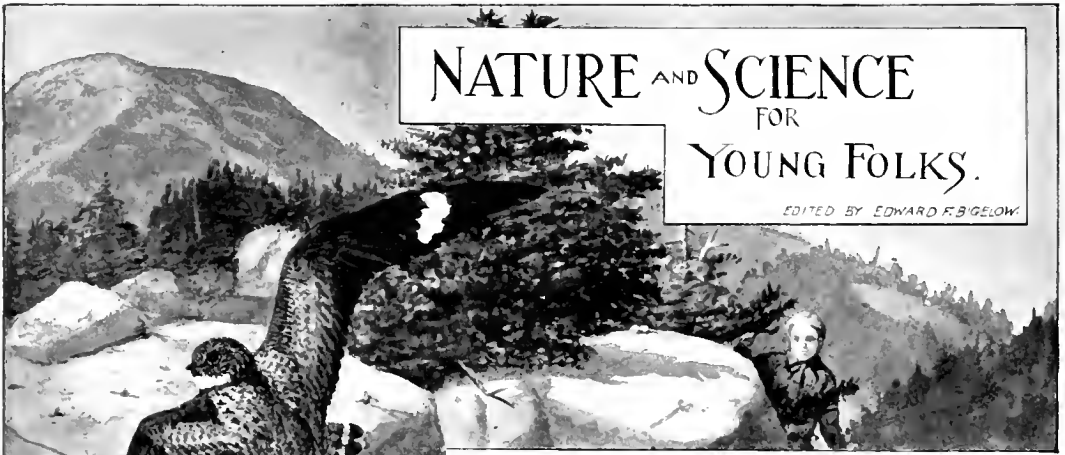

THE TWO EGGS ON THE ROCK. 19

THE MALE NIGHT-HAWK.

The male often assists in hatching the eggs.

THE BIRDS AT HOME.

WHAT is the matter with this night-hawk? Has he a broken leg or wing?

Not in the least. He is deceiving, in a manner common among birds that lay their eggs on the ground. He sat close on the eggs until the boy (it might have been a mink, cat, skunk, fox, or weasel) got almost to him. Then his courage failed, and he flew to save himself. But, as soon as he was a short distance away and had the full attention of the boy, he began to limp and flutter, and to display his bold black-and-white markings, trying to lure the danger a safe distance away from the nest, almost permitting himself to be caught. Then he flew away to safety, to return in a few minutes to the eggs. When the wings and tail of the male are folded the bright marks are all concealed, and nothing could be more beautifully "hidden in plain sight" than this same night-hawk. He is not only covered all over with little pictures of lichen and ground, but nature

has even painted out the shadows on the bird itself! I have seen persons (and very sharp-eyed ones, too) who could not see a night-hawk sitting on a bare rock twenty feet away, so perfectly was she "painted" into her granite surroundings.

But while the night-hawk is selecting a rock in the pasture on which to lay her pair of mottled eggs, the other birds are busy with many kinds of houses. The woodpeckers are hewing out their homes in the solid wood of the orchard trees; the crested flycatchers and bluebirds are peeping into attractive knot-holes; the vireos and orioles are weaving their graceful hanging baskets; the meadow-larks and ground-spar-



THE BALTIMORE ORIOLE ATTACHES A HANGING NEST TO A BRANCH

rows are neatly lining a corner under a tussock or at the base of some pasture weed; the queer

swifts are breaking off dead twigs for their curious little glued-up bracket-nest in the chimney; and the dainty, moth-like little humming-birds are at work on their tiny cradles of plant down, lichens, and cobwebs. All birds have great individuality. Some of this is manifested when they first arrive, but it is more marked in home-building and the care of young. Each kind has its own method of doing the regular household duties that come with a growing family. What a task it is to keep that nestful of yawning throats filled and quiet!

Swifts fly through the evening air, open-mouthed, trapping insects, like young folks with butterfly-nets. They store a quantity in



THE CHIMNEY SWIFT SIFTS THE "SIDE POCKETS" OF ITS MOUTH FULL OF LIES.
This is similar to the manner in which a chipmunk packs grain and nuts in its mouth "pockets."



THE PHOEBE MAKING A NEST UNDER THE PROJECTING EDGE OF A ROCK.

their great throat before dashing home to tumble down the black chimney to their clamoring young.

In the marshes, industrious little wrens are making their big round nests. Each nest has an opening down on one side. The parent birds may make or begin a dozen nests and use only one of them!

The phoebes are making their beautiful nests of moss and feathers under the rock ledges, the veranda roofs, or the country bridge. Later they will be hunting flies for their cavernous little ones. The sly cowbirds are silently searching for nests in which to lay their unwelcome eggs. The glossy, brown-headed blackbird that we see in the pastures has a bad name, as the dull-

colored females never make nests of their own, but foist their eggs on other and better mothers, who rear the hungry changelings at the expense of their own broods.

Wrens, chickadees, bluebirds, martins, and sometimes crested flycatchers will come to bird-houses in our gardens. Such houses should not be too new nor exposed. They should be arranged so that cats and squirrels cannot get to them. If they do come, we can learn much more by watching them a season than any book can teach us. Nearly all birds build nests for their eggs, each pair selecting a pleasant and secure place, while some kinds — mostly water-birds — form immense colonies.



THE MARSH-WREN BUILDS A NEST WITH THE ENTRANCE AT THE SIDE.

I have seen two thousand flamingos' nests in one community, and some of the guillemots breed in numbers vastly greater. Some birds



THE SANDPIPER PUTS ITS EGGS ON THE GROUND WITH BUT LITTLE IF ANY NEST-LINING.

build no nests, but, like the night-hawk, whip-poorwill, and some sandpipers, lay their earth-colored eggs right on the ground or among the dead leaves.

LOUIS AGASSIZ FUERTES.

SOUND GOES SLOWER THAN LIGHT.

ABOUT a thousand yards from the window where I sit is a factory which blows its whistle every noon. The steam always comes from the whistle some little time before the sound is heard. Yesterday I counted three seconds between the time when the first steam was seen and when the sound of the whistle was heard. This whistle is heard when the weather is foggy or clear; hot or cold; windy or calm. It is sometimes louder than at other times, but it always takes three seconds to travel the three thousand feet from the factory to my house.

We often hear also an echo of the whistle, which comes two seconds later than the first sound. This is the same sound coming by a roundabout journey five thousand feet long. It travels first one thousand feet to a hill beyond, and then is sent back four thousand feet to our house.

A few days ago I heard a band of musicians playing upon the street, and, although they were far distant from me, the high tones of the piccolo and the low tones of the bass horn reached me exactly together, showing that high and low tones travel at the same speed.

During a recent thunder-storm I noticed a flash of lightning, and counted ten seconds be-

fore the sound of the thunder was heard. This showed me that the storm was about ten thousand feet (or about two miles) away. A little later, however, the time between the lightning and the thunder began to grow less, and the noise of the thunder became louder, which showed that the storm was getting nearer. Finally a dazzling flash of lightning was followed immediately by a deafening crash of thunder, and at the same time the shingles flew from a patch of roof on a barn near by. It had been struck by lightning, and was soon in flames.

JOHN F. WOODHULL.

BARN-OWLS AT HOME.

A CURIOUS hissing noise came from the large red maple under which I was standing. Nothing was visible overhead to indicate the author of the curious sounds, and I realized



BARN-OWL AT THE AGE OF FIVE WEEKS.

that I was in the presence of a real mystery. After a rather difficult climb of some twenty-

five feet, a cavity was found leading into the heart of the tree. It had widened out from two weeks later, about the middle of June.



PREPARED TO DEFEND OLIVIER STROGDOLD AGAINST ALL COMERS.

the entrance into a good-sized chamber. Here, after my eyes had become accustomed to the darkness, were visible six young barn-owls, which crouched in the farthest corner. The mother bird awaited my next move in a defiant attitude. Quite a rumpus was raised in the family before three of the younger members were induced to sit for their pictures on a nearby log, an honor which the mother positively declined. Possibly she may have felt ashamed of her brood, for a more homely lot of youngsters never stood up to be photographed. From head to foot they were clothed in a suit of soft, yellowish down, and their long, solemn faces and little black eyes gave them a grotesque appearance. They did not object at all to being handled.

One little fellow was only about half as large as his brothers, and was probably fully a week younger. They were returned to the

nest in good order; and I again visited them two weeks later, about the middle of June. This time the mother bird was not at home, but the younger members were well able to uphold the dignity of the family. In the interval of two weeks they had learned to use beak and claws wonderfully well. When trying to get them into a good position to photograph, although scarcely able to stand erect, they would crouch and spring at me, falling over each other in their efforts to reach the enemy, in a way that was very funny. The beautiful brown wing-feathers were just showing, and the curious disks around the eyes were bordered with a band of brown, and for the first time you realized that they were beginning to look like



THEY HAVE LASHED ASIDE THEIR DOWNY BABY-CLOTHES, AND ARE DRESSED IN A BRAND-NEW SUIT OF FEATHERS OF THE LATEST STYLE.

real owls. So interesting had they become that I decided to take them home in order more leisurely to watch further developments.

They showed great aversion to the cat, and whenever pussy came near she was sure to be greeted with a loud snapping of beaks and a threatening chorus of hisses, and she never seemed to desire any closer acquaintance.

THOMAS H. JACKSON.

ANTS' COW-SHEDS.

ONE of the most interesting studies of insect life is the relationship between ants and plant-lice, or aphids. These plant-lice supply honeydew from the juices which they take as food from plants. The ants are very fond of this sweet substance, and care for the aphids in a manner that seems to us surprisingly intelligent. They sometimes carry them bodily to a better feeding-ground and drive away certain of their enemies. It is claimed that they even build sheds of mud in the crotches of shrubs and small trees. On account of this insect relationship, one may truthfully call the ants



ANTS' COW-SHED.

Natural size, on dogwood. Made of mud. "There were six or eight plant-lice on the branch within the hollow mud shed, and small ants were going out and in the round hole seen near the center."—From a memorandum by Professor M. V. Slingerland, who took this photograph.

"farmers," the aphids "cows," and these protecting mud cases "cow-sheds."

THE BULLFROG WANTS TO KNOW.

PERMIT me to inquire why the young folks were writing about my ears last month (see Nature and



Science, page 655). Why did n't they say something about my mouth and eyes? Are n't they conspicuous enough? I am quite proud of them.

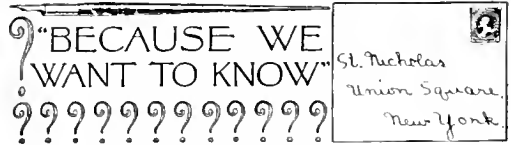

FROZEN FISH.

STEPHEN, MINN.

DEAR ST. NICHOLAS: In the last part of winter, as a friend of mine and I were walking on the frozen river, we found many little fish, about six inches long, lying on the ice, and also hundreds of minnows scattered over the ice around a hole. There was ice about three inches thick in the hole, and we took stones and broke it.

The water in the hole was filled with frozen minnows and little fish, and the ice which we had broken was a mass of frozen fish. As we were looking at the fish we noticed that little fish came to the top of the water to breathe, as we believed. We walked farther down the ice and saw innumerable minnows and fish lying frozen under the ice. They were not in contact with the ice, unless there was ice on the bottom of the river. Please tell me how it happened that there were so many frozen fish, and how so many should be found on the ice.

Your faithful friend,

CARL OLSEN (age 13).

It seems probable that some one had cut the hole in the ice to catch minnows for bait.

Minnows and other fish are attracted to such a hole, as is well known. The angler caught his minnows, but had more than he needed, or else did not use them at all, and threw them away. Some remained on the ice, some fell in the hole and stayed there, and others fell in the hole and were washed under the ice.

PHOTOGRAPHING LEAVES WITHOUT A CAMERA.

TWIN OAKS, WASHINGTON, D. C.

DEAR ST. NICHOLAS: I send you four photographs of different leaves. One is the skeleton or lace plant, a rare plant (*Ocrotandra fustulata*), from the island of Madagascar. It grows entirely submerged in the water. The others are two Japanese-maple leaves, a white-oak leaf, and a maidenhair-fern leaf. I will tell how to do it. First get a printing-frame and a clear glass to fit it. Put the glass in with the leaves face up, then put the prepared side of the paper down on the leaves, then put the back on and clamp it. Do this in dim light. Next is to print it. Put it under an electric light or a gas-light for a few seconds. Do this with such paper as velox. With solio paper you have to print in the sun until deep enough, then tone as desired. If you do this right, you can make pretty designs.

DAVID BISSET (age 12).

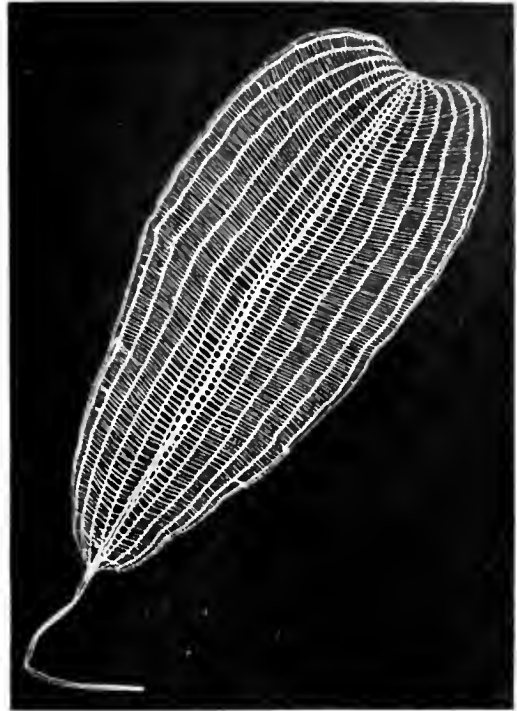

LEAF OF LACE-PLANT.

Of the four photographs received with this letter, that of the lace-plant and of the maidenhair fern are published herewith. See article, "Photography without a Camera," page 842, Nature and Science for July, 1903.

SQUIRRELS ROB BIRDS' NESTS.

THREE LAKES, WIS.

DEAR ST. NICHOLAS: Do squirrels rob birds' nests and eat the eggs and little birds?

KEITH DONNELLY.

So far as I am aware, the red squirrel is the only one of our true squirrels which habitually robs birds' nests of their eggs and young. The gray squirrel, on occasion, has been reported to do the same thing, and some of the Western chipmunks have been accused of being as destructive to eggs and young birds as is the Eastern red squirrel.

C. HART MERRIAM,

Chief, Biological Survey.

It is charged that the gray squirrel sometimes devours the eggs of wild birds, but I have never known of its being accused of devouring young birds. I think it is entirely probable

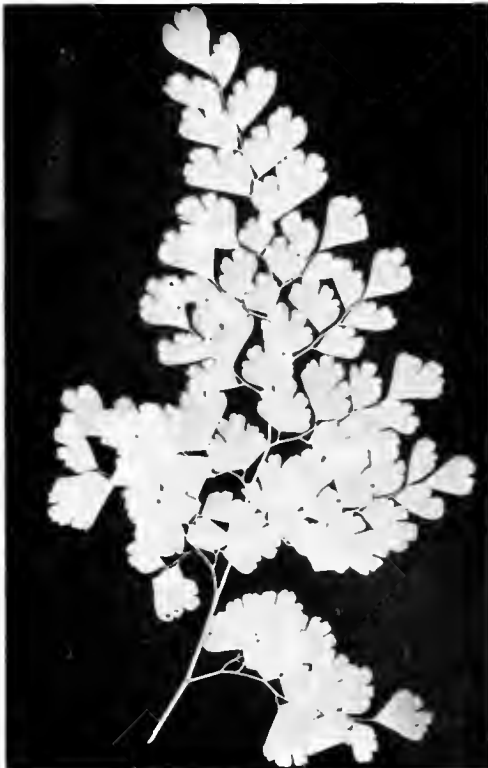

PART OF FROND OF MAIDENHAIR FERN.

that occasionally the gray squirrel does commit the offense charged in regard to eggs; but oc-

fish so afflicted would be to take them to a goldfish-dealer for treatment.

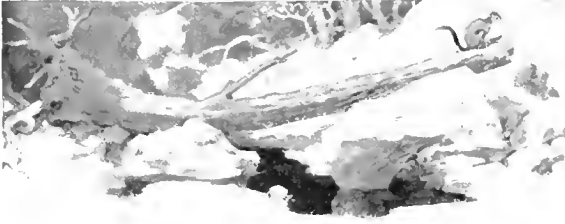

"THE RED SQUIRREL HABITUALLY ROBBS BIRDS' NESTS OF THEIR EGGS AND YOUNG."

Where did you get your unholy and horrible craving, Chickaree? Is there weasel blood mingled with the squirrel in your veins? You are deprived past relief—seven times worse than the weasel, for his blood-thirst is natural. The black-snake and turkey-lizzard are almost moral compared with you. You are everything wicked, you have earned your evil reputation. — SHARP.

currences appear to be so rare as not to constitute a serious offense, and even those who are most strenuous about protecting birds have not demanded the destruction of the gray squirrels.

W. T. HORNADAY,

Director New York Zoological Park.

DOWNY GROWTH ON GOLDFISH.

BOSTON, MASS.

DEAR ST. NICHOLAS: I have a bowl of goldfish, and one of them has a downy growth on it. Will you please write me the meaning of it? Hoping to hear from you soon,

I am your loving friend,

SUSAN J. APPLIX.

This growth is the plant known as *Saprolegnia*. This is commonly called "fungus," and attacks fishes when the skin becomes injured or sore, frequently killing them. If it has not been growing too long, or is not too wide-spread, it may be destroyed by salt water. Remove the fish to a separate vessel containing water with about a tablespoonful of common salt per quart. Watch the fish, and when it begins to turn upon its side remove it to fresh water. Do not put it back in the bowl with the other fish until cured, as it is apt to transfer the fungus to them.

H. M. SMITH,

Bureau of Fisheries, Washington, D. C.

Formalin is sometimes applied by an expert. Probably the best way for you or others with

LARGE SHELLS FOR FONTS AND VASES.

DETROIT, MICH.

DEAR ST. NICHOLAS: I saw a picture of a *Tridacna* in the February number of ST. NICHOLAS, and will be glad to tell you they are used in the Philippines and in our church (St. Stephen's). We have it as a font. In Spanish houses they are used to hold flowers. They are very common over there. I hope the readers of the ST. NICHOLAS will enjoy what I have told. Your loving reader,
DUNCAN Mc GREGOR.

Tridacna shells are very commonly used in churches in Europe for holy-water basins and even fonts. The largest, perhaps, are those in use at St. Peter's, Rome. These shells attain a weight of five hundred pounds (the two valves together), the animal itself sometimes being twenty pounds in weight.

The word *Tridacna* is from the Greek *tri-daknos*, eaten at three bites; but who could eat a twenty-pound animal at three bites!

INTERESTING OBSERVATIONS OF BIRDS' NESTS.

DEAR ST. NICHOLAS: There is a dear little house-wren's nest in an old disused pump near where we are



THE TREE-SWALLOW THAT NESTED IN A PUMP

staying. The wren goes in from the top and comes out under the handle. There are six lovely brown eggs. Another queer place for a wren's nest is in a canvas

clothes-pin, apron with pockets. A house-wren has built in a frier's back yard, in a hole in a log-pole.

We put out some red yarn for a crow who was building a nest, and she took it and wove it into her nest, making it a flaming red.

Your interested reader, PRUDENCE ROSS.

Dallas Fore Sharp tells of a tree-swallow that also nested in an old pump. I have heard of a wren that built a nest in a broken tea kettle on a rubbish-heap.

limping down the slope as though he were lame, thus seeking to deceive the little girl and her brother. Was that not very queer?

CATHERINE E. CAMBELL.

The pheasant *Phasianus torquatus* to which you refer is known as the Mongolian, Chinese, or Denny pheasant, because it was introduced in your vicinity from China by Judge O. N. Denny in 1883-84, and they are now quite numerous in your section of the State.

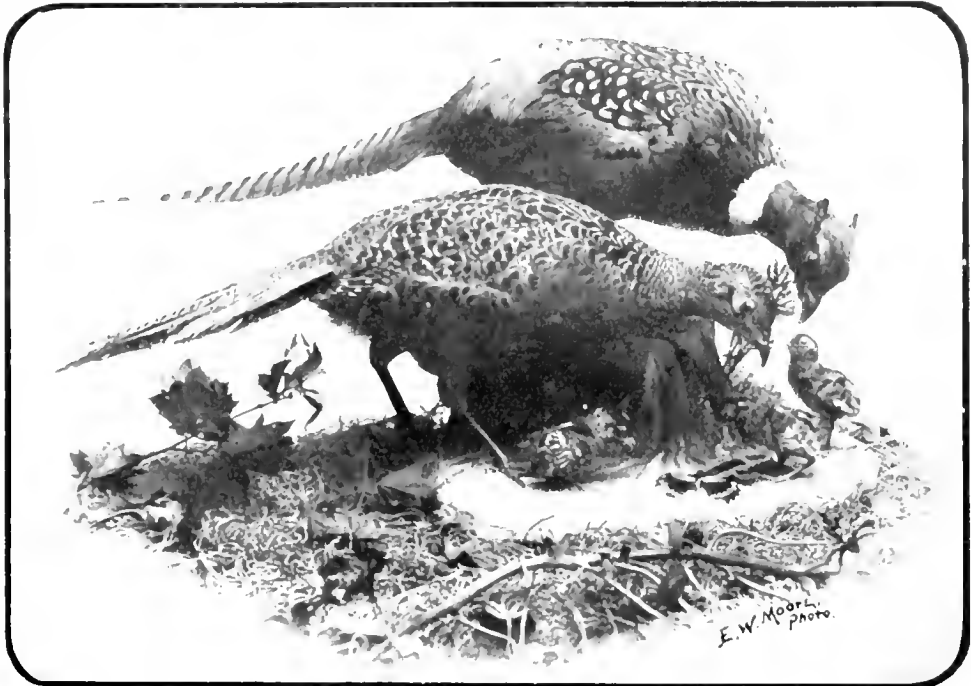

THE HINEY OF DENNY PHEASANTS FEEDING YOUNG.
(Cut lent by the Oregon Agricultural College, Corvallis, Oregon.)

DISCOVERY OF A CHINA PHEASANT'S NEST.

MONMOUTH, ORL.

DEAR ST. NICHOLAS: One day in early spring a China pheasant built her nest, of horse-hair and dry grass neatly woven together, on the ground near a small oak-tree. The mother bird was very proud of the nest she had built and the nine precious eggs which it contained.

On a bright Sunday afternoon, as she was brooding on her nest (I imagine that she was thinking of the time when she would have nine little ones, and how happy they would be), suddenly she heard a noise of children's voices in the woods. Crouching low upon the nest, she thought at first to avoid being seen; but a little girl, reaching for a flower that she wished, came so near the hidden nest that the mother felt obliged to fly. She flew directly into the little girl's face and ran off

The females are exceedingly timid and shy, and I presume the act of the bird flying in your face was purely accidental, as they usually fly in the opposite direction from one approaching them.

As most young folks know, the game birds of other species also feign lameness for the purpose of withdrawing attention from their eggs or young when either of these are too nearly approached. The male night-hawk thus deceiving as to wounds or lameness is pictured in the heading of this number of Nature and Science. Will young folks please write of other observations of birds as hypocrites?

THE ST. NICHOLAS LEAGUE FOR JUNE.



"FAIRY STORIES." BY D. M. SHAW, AGE 14. (CASH PRIZE.)

FAIRIES.

BY EDITH J. MINAKER (AGE 13).

(Honor Member.)

I HEARD among the willow boughs
A gentle, whispering, sighing sound,
As though amid the swaying leaves
A host of moving forms were found,
Whose draperies, touching as they moved,
The willow twigs bent
to and fro.
My mother says 't was just
the wind;
I think it was the fairies,
though.

Last night, before I went
to sleep,
Closed tightly was the
tulip's cup,
It must have been a fairies'
bed,
Because this morn 't was
opened up.
What made it close its pet-
als soft,
And open with the sun-
rise glow?
My mother says 't was na-
ture's ways;
I think it was the fairies,
though.

There are so many, many
things
I cannot understand at
all,
And even mother does n't
know
Just why the snow and
rain-drops fall,
And yet they say there are
no sprites
Or fairies, when they do
not know
How else such curious
things could be,
I think there *must* be
fairies, though.

ST. NICHOLAS LEAGUE.

THIS month we have a genuine fairyland number, something out of the usual order of our competitions.

The poems, the stories, and the drawings are all of the little people that we so seldom see, yet hear of so much, whose stories have made children happy ever since the first fay strung dewdrops for diamonds, chimed bluebells for music, or hoarded dandelion petals for gold.

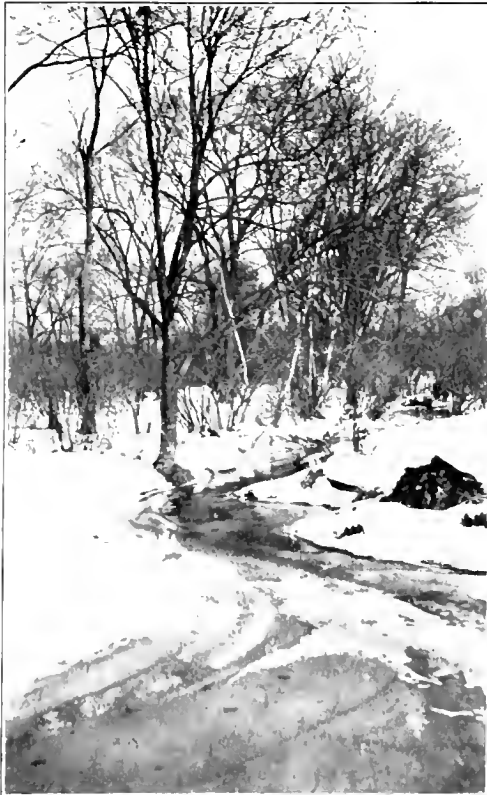

"MARCH." BY HANFORD MACNIDER, AGE 15. (GOLD BADGE.)

We do not often see them at work or at play, for they are like thin air and perfumes and electric waves — we cannot perceive them with the ordinary eye. There are even persons who, because they cannot see the fairies, and examine them with microscopes, and weigh them in scales, will tell you that there are no fairies, that whatever we cannot perceive with one of our five imperfect senses cannot exist, and that we are very foolish to think otherwise.

We always feel very sorry for such people. There are so many things we cannot see and weigh and handle, yet that mean so much to the world, and make us all so much happier. — beautiful thoughts, for instance, and hope, and sympathy, and forgiveness, — that one might almost believe these are the best of life — the real things — and that all the rest are as nothing without them. And as for fairies — why, they are the fairies who bring these things; if not, then by what means do they come to us?

We say, "The thought suddenly came into my

head." True, but how did it come then? The wise man who solemnly declares that there are no fairies will have a hard time to answer that question. He will use a great many long words trying to explain what you will never understand—words that he uses only to cover up the fact that he does not understand, either. But all the time we, who believe in fairies, know; and when we explain that the fairies bring the thoughts, and the dreams, and the impulses, and that they attend to the flowers, closing some of them at evening, and opening them again the next morning, making the vines and trees always grow in graceful forms, even in winter tracing their loveliness on the window-panes, we use only such simple words that any one can understand them; and if the solemn man gets angry and growls that there are no fairies, we will make him prove it, and he will have to invent a great many more long, hard words before he can do that. He has been trying to get words big enough to explain about thoughts and dreams, and the habits of flowers, and the wonders of electricity, for a good many years; and he has never yet been able to do it in a way that he can even understand himself.

But there is a scientist we know—and there may be many more—who, though he has invented the most delicate of all instruments for measuring light and heat, and has gone further into the things we cannot see with our eyes and feel with our fingers than any other living man, is still the strongest champion of the "little people," and finds, he says, his greatest comfort and happiness in "children and fairy stories." Perhaps Dr. Langley, who is secretary of the Smithsonian Institution at Washington, where he has arranged a room of wonders for children alone, would not profess a complete scientific faith in Titania and Oberon and Puck and all the rest; yet we feel sure he likes to think that round and about us there are hordes of little helpers we cannot see, and that upon moonlight nights they do assemble in the forest glades or dance upon the village green. Like us, he knows that the faith, the memories, and the fancies of childhood are the best treasures to preserve for later years. Perhaps it is well to be wise and serious, but not overwise nor over-serious; and certainly it is not well to begin these things too soon.

PRIZE-WINNERS, COMPETITION No. 66.

IN making the awards contributors' ages are considered.

Verse. Gold badges, **Dorothea Gay** (age 16), 205 W. 100th St., New York City; **Eleanor R. Chapin** (age 12), 79 Porter Place, Montclair, N. J.; and **Lewis S. Combes** (age 8), Amesbury, Mass.

Silver badges, **Margaret Ewing** (age 12), 629 McCallie Ave., Chattanooga, Tenn.; **Martha Stringham** (age 14), Box 29, Pacific Grove, Cal.; and **Mary Eloise Grabill** (age 6), Takoma Park, D. C.

Prose. Gold badges, **Marjorie Miller** (age 13), 6055 Hurst St., New Orleans, La., and **Marjorie R. Peck** (age 14), Oxford, Conn.

Silver badges, **Marion Leonard** (age 9), Fort Russell, Wyo., and **Helen Spears** (age 11), Llano, Tex.

Drawing. Cash prize, **D. M. Shaw** (age 14), Tor Villa, Watts Road, Tavistock, Devonshire, England.

Gold badges, **Edward L. Kastler** (age 16), 1824 College Ave., Racine, Wis., and **Oscar Schmidt** (age 13), 468a McDonough St., Brooklyn, N. Y.

Silver badges, **Frieda Zimetmann** (age 16), St. Mary's School, Knoxville, Ill.; **C. H. Bradley** (age 15), Albright House, Northampton, Massachusetts; and **Anna Furman Goldsmith** (age 14), 4 Gardner St., Salem, Massachusetts.

Photography. Gold badges, **W. L. Irish** (age 15), The Hamilton, Norristown, Pa., and **Hanford Macnider** (age 15), Milton Academy, Milton, Massachusetts.

Silver badges, **Robert L. Ackerman** (age 13), 3222 Jackson St., San Francisco, Cal.; **Charlotte L. Eaton** (age 11), 153 Mountain Ave., Montclair, N. J.; and **Kenneth Horner** (age 13), 181 Kansom St., Grand Rapids, Mich.

Wild Animal and Bird Photography. First prize, "Deer," by **Anna Clark Buchanan** (age 13), 664



"MARCH" BY W. L. IRISH, AGE 15. GOLDEN DOG.

Philadelphia Ave., Chambersburg, Pa. Second prize, "Flicker Leaving Nest," by **C. H. Pangburn** (age 16), 731 Elm St., New Haven, Conn. Third prize, "Rabbit," by **Robert Bartley** (age 15), Sandwich, Massachusetts.

Puzzle-making. Gold badge—**Elizabeth Beal Berry** (age 13), 823 Federal St., Camden, N. J., and **Leslie V. Spencer** (age 13), 121 Bank St., Batavia, N. Y.

Silver badges, **Gladys Richardson** (age 10), St. Gabriel's School, Peekskill, N. Y., and **Myron K. Barrett** (age 9), 116 W. 118th St., New York City.

Puzzle-answers. Gold badges, **Harriet Bingaman** (age 15), 704 Chestnut Ave., Altoona, Pa., and **Jessie W. Clifton** (age 14), 3218 Mt. Vernon St., W. Philadelphia, Pa.

Silver badges, **Florence Du Bois** (age 16), 232 N. Emporia Ave., Wichita, Kan., and **Elisabeth Morss** (age 13), Salt Spring Rd., Syracuse, N. Y.

SUMMER FAIRIES.

BY LEWIS S. COMBES
(AGE 8).

(Gold Badge.)

AIRY little fairies
Dancing in the sun;
Playing all the daytime,
Having lots of fun.

Hungry little fairies,
Eating honey sweet
Hidden in the blossoms,
Think it is a treat.

Thirsty little fairies,
Sipping drops of dew
Sparkling on the roses
And the grasses too.

Tired little fairies,
Resting all the night;
Sleeping in the flowers,
Cuddled up so tight.

VACATION~DAYS

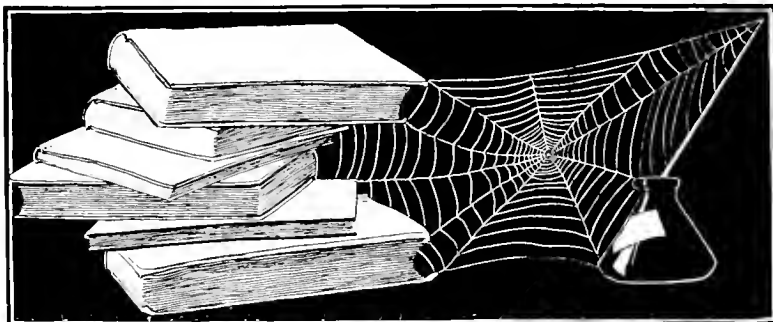

"A HEADING FOR JUNE." BY EDWARD L. KASTLER, AGE 16 (GOLD BADGE.)



"A HEADING FOR JUNE." BY FRIEDA ZIMMERMANN, AGE 16. (SILVER BADGE.)

THE THREE PEARLS.

BY MARJORIE MILLER (AGE 13).

(Gold Badge.)

THE princess was crying. But she had plenty of reason for it, for her mother was dead. Her father had died so long ago that she did not even remember him. And, then, the princess was only seventeen. But in the midst of her crying she heard a sound, and, looking up, she saw her fairy godmother standing beside her. How she knew that it was her godmother I do not know, for she had never seen her since her christening; but she did know, anyway.

"Althea," said her godmother, "you are a queen now. Your parents made me your godmother because they thought I could help you to be a good queen, and that is what I am here for. Here is a necklace with three pearls on it. The pearls represent three wishes, which you must make before you are eighteen. Be careful of them, for they are far more precious than these emblems." So saying, she vanished, leaving the necklace behind.

Althea immediately forgot what she had been thinking about, and began to wonder what to wish for. At last she decided that she would never be sorry if she should ask for beauty. As soon as she had made her wish one pearl disappeared from her chain, and she found her appearance was quite different.

When the mourning for the old queen was over, Althea was crowned, and she found that beauty is not the most important thing in life, especially to a queen. For her army was continually at war with the neighboring countries, and it was more often unsuccessful than victorious. Finally, Althea determined to make her second wish one for more power than any other king or queen. Soon her armies became universally victorious, and her domains increased rapidly. But this only added to her cares, for the newly conquered countries were troublesome, to say nothing of one country that she could not overcome.

About this time Althea's godmother once more appeared before her.

"Do you know why you cannot conquer the King of Noland?" she asked. "It is because I gave also to him, my godson, three wishes, and he wished for the most power of all the world. The only way whereby I may fulfil both of your wishes is for you two to be married.

Are you willing?"

"If he is," said Althea.

So they were married, and lived happily for many years; but Althea forgot her last wish.

THE PRINCESS OF THE GREEN HOOD.

BY MARJORIE R. PECK (AGE 14).

(Gold Badge.)

TITFRE once lived a king who had a beautiful daughter. Her father wished her to marry a king old and



"MARCH." BY ROBERT L. ACKERMAN, AGE 13. (SILVER BADGE.)

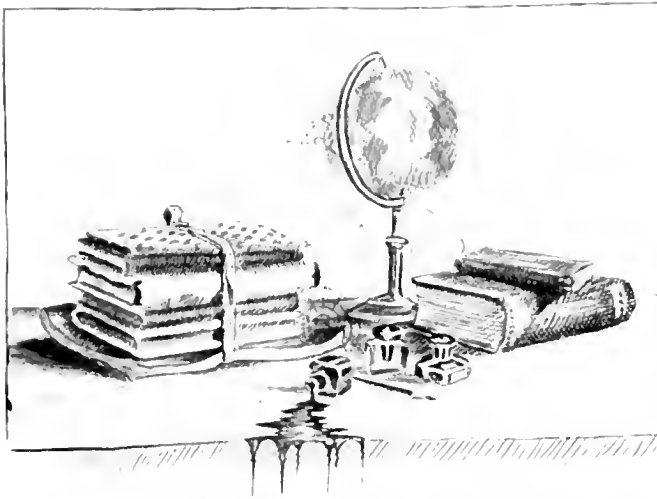

"A HEADING FOR JUNE." BY OSKAR SCHMIDT, AGE 13. (GOLD BADGE.)

tyrannical. She resisted, but was finally forced to marry him. He took her home to his great, gloomy castle in the midst of a thick wood, and then what a life she led!

Every spring the king went to visit his other estates, leaving the princess locked in a tower, with food enough to last until his return.

There came a time, however, when the princess decided that she could stand it no longer. The king was to set out on one of his spring journeys. He had been working hard all day and was very tired; everything seemed safe, so he fell asleep in the garden.

But the guards at the castle gate had fallen asleep, too. The princess, noticing this, hastily threw a green cloak over her shoulders, tied a green hood over her golden curls, and tiptoed through the gate.

Once outside, she ran swiftly through the wood until she dropped exhausted beside a brook.

Crouching down among the tall grasses, she pulled her green hood closer about her face and waited, hardly daring to breathe.

Suddenly she felt a light touch upon her head, and, looking up, beheld a fairy resting on a fern. "What is

the trouble, sweet maiden?" she asked. When the princess had told her story the fairy said, "I will help you!" and, gently touching the princess with her wand, transformed her into a beautiful flower.

The king searched the woods for two days, and then, giving up, started on his journey in a wrathful mood.

Year after year the princess remained beside the brook, only daring to show her face in the spring, when she knew that the king had gone on his journey.

The descendants of this fair princess still dwell in quiet nooks along the banks of brooks.

When they first appear, their green hoods are drawn closely about their white faces; but when the sun grows warmer and they are sure it is spring, they gain courage, and, flinging back their soft hoods, reveal their hidden charms.

If a person picks one of these flowers his hands are stained with blood, which proves their descent from a mortal. To this day the beautiful flower which blossoms beside the brooks in the spring is called the bloodroot.

JUNE



"A HEADING FOR JUNE." BY C. H. BRADLEY, AGE 10. (SILVER BADGE.)

THE FAIRIES' DANCE.

BY DOROTHEA GAY (AGE 10).

(Gold Badge.)

THE moonlight is glittering, a soft subdued twitt'ring
Comes from the nestlings far up in a tree;

A light wind is wafting a soft, gentle sav'ring
Of primrose and daisy abloom on the lea.

Through the forest comes stealing a strange, very
feeling;

It spreads through the brush and creeps over
the mere.

The moonlight seems brightened, the green moss
is lightened;

A soft glow of foxfire—the fairies are here!

O'er the grass they come tripping, some flying,
some skipping;

Half drifting they seem, for they scarce touch
the ground;

In the glade they are swarming, their ranks
quickly forming

To join in the dance round the green elfin mound.

The bluebells start chiming a soft cadence, timing
The feet of the dancers who airily tread



"MARCH." BY CHARLOTTA L. LATO, AGE 11. (SILVER BADGE.)



"DEER." BY ANNA CLARK B. CHANAN, AGE 13. (FIRST PRIZE, "WILD-ANIMAL PHOTOGRAPH.")

Mystic mazes and twirling—the whole mass seems
whirling
In serpentine twistings by royalty led.

The day is approaching; its light is encroaching
On the time of the dancers—already 't is dawn.
See! the mound has yawned
wide—trooping in at its
side
With an echo of laughter,
the fairies are gone!

THE FAIRY RING.

BY MARION LEONARD
(AGE 9).

(*Silver Badge.*)

You all know how water sparkles by moonlight. I will tell you why it sparkles in beautiful Lake Lanao. Once a terrible giant ravaged everything around the lake, murdered people, and took their food. None dared oppose him. Finally, a Moro prince went to the mosque and vowed, by fire, earth, water, and the Prophet's beard, to slay the giant or die in the attempt. At this the priest placed upon the prince's right hand the most beautiful diamond ring ever seen, and said: "Go forth, my son; conquer in Ali's name. This ring, made by

the genii [or fairies] of Persia, will reveal hidden danger, but only once." Armed with spear and creese, the prince bravely set forth. He found the giant sitting on a rock, and challenged him to mortal combat. The giant grasped his terrible kampilan, sprang up, and struck at the prince. The magic ring then revealed to the prince that the giant, mortally wounded by one blow, must die like any man; but if struck a second blow two giants equally terrible would take his place. With steady aim the prince hurled his spear into the giant's body; but the ring also left his hand and fell into the lake. The giant sank to his knees and begged the prince to strike one more blow, and so end his pain. But the prince, being warned, refused to do this. The giant, then hoping to force a blow in self-defense, sprang up and again rushed at the prince, who turned and fled around the lake until he reached the Agus River, too deep, wide, and swift for man to cross. His pursuer, seeing his advantage, raised the fearful kampilan to strike. But the wound and the exertion of pursuit had done their work. The weapon paused in mid-air, trembled, and fell from the giant's nerveless fingers, and the giant sank dead.

At Marahui the Moros still point to a huge hill which, they say, is the giant's body turned to earth. When the moonlight glints on the lake they say it is the reflection of their prince's magic diamond ring.

THE GARDEN-SEEDS.

BY HELEN SPEARS (AGE 11).

(*Silver Badge.*)

LITTLE Mary Arden lived with her grandmother, who was old and feeble and very poor.

Mary was sitting in the yard one day, looking very thoughtful, when suddenly there appeared a tiny little lady, who said, "What are you thinking about, little girl?"

"I am trying to plan a way to get some garden-seeds."

"You had better get your garden ready for the seeds, and then by that time you might think of some way to get them." Then the little lady vanished.

Next morning Mary prepared her garden, and finished it in time to get dinner. Her grandmother sent her to town for groceries that afternoon, and she was disappointed when she found she had no money left for the seeds. As she was returning she saw an old man sitting by the roadside, who said to her, "I am blind, little girl. Will you kindly lead me into the city?"

Mary gently took him by the hand, and patiently retraced her steps. On reaching there, the old man patted her on the head and said, "You will not lose your reward."

It was a happy but tired little girl who reached home that afternoon; and when she went to her garden, to her surprise she found it full of luxuriantly grown vege-



"FLICKER LEAVING NEST." BY C. H. PANGBURN, AGE 10. (SECOND PRIZE, "WILD-BIRD PHOTOGRAPH.")

tables. Strange thoughts of the old man stole into her mind. When she and her grandmother were sitting at the table there was a rap at the door. Mary opened it, and there stood an old woman, who asked to stay all night there. Mary said she could, and the old woman sat down in the chair Mary had placed for her. She ate supper with them, and when bedtime came there was no place for her to sleep; so Mary let her have her own bed, while she slept on the floor on rugs.

Next morning, while Mary was cooking breakfast, the fairy that she had seen in the yard again appeared and said: "I will give you a wish for your kindness to the stranger last night. Now, what will you have?"

"I wish," said Mary, "that grandmother were strong and well again."

"You have wished well, my child; and I will not only grant this wish, but will give you what you will see if you go in the yard." And Mary went and saw a beautiful castle, and her grandmother on the front steps of it, well.

Mary spent many happy years in this beautiful home with her grandmother.

THE FAIRY-BOOK.

BY ELEANOR K. CHAPIN (AGE 12).

(Gold Badge.)

MOTHER is out to-night to tea;
There's no one at home save the cat and me

And the nodding cook,
The wind may howl to its heart's delight,
But what care I, by the firelight bright,
With a fairy-book?

Without, the snow is drifting high;
The clouds in yonder northern sky
Have a threatening look;
The kettle sputters, the fire is low,
Oh, what care I for the drifting snow,
With my fairy-book?

The storm may rage the whole night through,
It matters not to me, nor you,
In our favorite nook.

Till Prince is married—the
quest is o'er—
I sit and read the mystic
lore
Of the fairy-book.

THE STORY OF ALMA.

BY LOIS F. LOVEJOY
(AGE 14).

ONCE upon a time there lived a family in a far country. It consisted of the father and mother, Alma, and her baby brother. They were poor, and kept getting poorer each year. At last one day they had nothing to eat. "What shall we do," wailed the mother, "without even a crust to give to my poor baby?"



MARIE BY LEWIS KADG, AGE 11. (GOLD BADGE.)

Alma, who could not bear to see her mother unhappy, said, "I will go out and see if some one won't be kind enough to give me some food for you." So she started out, and many people heard her plea, but none heeded it. She walked and walked, till she could go no further without food. Just then she came to an old man eating by the wayside. "Give me a crust," cried Alma, "or I starve." The old man grumbled, but broke off a small piece and gave it to her. She had just begun to eat, when she came to another old man, lying on the ground, apparently exhausted. "Poor man," thought Alma, "he needs bread more than I." And so she stooped down and gave him all she had left, saying,

"Here, little father; eat this and you will be stronger." The old man sat up and took the bread in his hand. Then a wonderful thing happened: for, as Alma watched with wide-open, wondering eyes, the small piece of bread grew and grew and grew, until it was the largest and best-looking loaf that she had ever seen. And not only that, but the old man grew tall and straight and handsome.

"Here, little one," he said, putting the loaf in her hand; "take this home, and because of your kindness and unselfishness, every time that a slice is cut from it another will appear in its place."



"RABBIT" BY ROBERT BARTLEY, AGE 13. (THIRD PRIZE.)

"Oh, sir—" began Alma, but he had vanished; and, turning, she found that she was just outside her own door. So she went in and told her father and mother what had happened. How glad they all were!—and Alma most of all, because she knew that it was unselfish kindness that had procured for them this wonderful gift.

THE FAIRIES' SLEEPY TIME.



BY MARTHA SRINGHAM (AGE 14).

(Silver Badge.)

The dear little daisies are nodding their heads,
The roses and violets are dozing,
The insects are safely tucked into their beds,
And the fairies their bright eyes are closing.

The firefly flits to and fro with his light,
While the glow-worm helps out with his ray,—
They see that each fairy is safe for the night,
From the queen to the tiniest fay.

The warm summer breeze a low lullaby sings,
While the moon gives his silvery light.
To the wee, tired fairies, with soft folded wings,
Good night, little fairies, good night!

A FAIRY COUNCIL.

BY SIBYL KENT STONE (AGE 15).

IF you had been out that night, and had kept your eyes open, you would have been surprised. For Titania was about to hold her court in the wood. Though the birds slept, many helpers waited to lend assistance when needed. First, there was the moon, big and yellow, up in the blue-black sky, and the stars, shining steadily and cheerfully. In the shadows flitted miniature stars, the fireflies, whose duty it was to help the moon and smaller companions provide the light.

There was a subdued bustle among the trees. The fireflies were settling into twinkling rows; an occasional June-bug blundered through the branches, shaking down showers of fragrant dew. Suddenly a hush fell upon the assembly, and with a little rustle all the fairies, rising from their seats, remained standing as their queen walked up and took her place on the throne. When all was still she said: "My people, I called you hither for serious council. Last night, while we were gaily dancing, a dreadful deed was committed. The red fox killed the rabbit's babies. Had he hungered, there were some excuse; yet he did not, for he left them stiff and cold beneath these trees. Should he not pay the penalty of his crime with his life?"

Cries of "Yes! Yes!" arose from the fairies. When all was again quiet, Titania continued, "Poppy and Kose, be it your task to cover the victims with fragrant petals." At the mention of their names two fairies bowed and soon disappeared. "Foxglove, track the murderer to his lair; and when you have found it, fly to a mortal's dwelling, guide his foot-steps thither, and whisper in his ear of the rascal's fine, smooth coat, that a trap may be set before his den and—"

The moon blinked warningly, and suddenly all the fireflies began to fly about excitedly. Some of the fairies screamed; then, darkening the bar of moonlight,

a shadowy shape, the red fox, drifted between the tree-trunks and vanished.

A cloud floated across the moon's face, and another, until the sky was gray. Finally a soft summer rain began to fall, and the wood, once full of fairies, was dreary and bare. It might have been a dream, but the red fox was caught the next day.

THE FAIRIES' DANCE.

BY MARY FLOISE GRABILL (AGE 9).

(Silver Badge.)

WHEN the sun sank down behind the hills,
And the breezes ruffled the dancing rills,
When the stars and the moon shone bright and clear,
Then all the fairies did appear.

They danced so long on the mosses green
That a tiny pathway could be seen.
They danced in the light of the glimmering moon
Till morning came, too fast—too soon.

LUCY'S LESSON.

BY ELIZABETH HIRSH (AGE 12).

LUCY FROST lay on the worn old lounge, reading one of the books that the kind lady at the big house had given her. Shutting the book, she heaved a great sigh.

"Oh, if I only had one Fortunatus's purse, I'd give up everything."

As she spoke, a fairy appeared before her.

"Lucy," said the beautiful being, "if you really mean what you say, take this purse; but you must promise me not to read any books during the time you keep the gold."

"Oh, yes, I promise," said Lucy, eagerly; and the fairy vanished as suddenly as she had appeared.

Lucy bought many things with her magic purse, and



"FAIRYLAND." BY ANNA FURMAN GOLDSMITH, AGE 11
(SILVER BADGE.)

the Frosts built a large castle and surrounded themselves with every possible luxury. But in all this grandeur Lucy lacked one thing, and that was books. Never in her life did she yearn for them as now, and she would have nothing to do with her fine gowns and jewels. Time went on, and the temptation became too

THE FAITHFUL PRINCESS.

BY HANNE READ SAMERSON (A. G. L. 15.)

(Honor Member.)

Just a month before the marriage of Prince Charming and Princess Rosalie a dire calamity befell the kingdom. The prince was changed into a bird, and the princess carried into captivity by an ogre called Fearsome.

One night Rosalie awoke and saw a fairy standing in the dungeon beside her.

"Rosalie," she said, "keep up a stout heart. You are so good that I will help you. Escape now to Delphi, to the Nymphs, where you may obtain any request if you answer three questions. Take with you strength and fortitude. Beware of vanity and self-conceit. You will receive aid. I dare promise no more." So saying, she vanished.

Rosalie now hastened to the door, which yielded to her touch. Scarcely had she gone two miles when the ogre started in pursuit. Mile after mile she ran, encouraged by the song of a bird—her lover. Steadily Fearsome gained on her, and it seemed that she must be overtaken, when she saw a blacksmith shop. The blacksmith, pushing a stool toward her, said, "Sit here, and beware of vanity." The ogre, seeing her temporary place of safety, pulled a hand-mirror from his pocket. Rosalie closed her eyes. Had she looked, she would have been in his power; but as it was, Fearsome was forced to retreat a mile.

Rosalie now resumed her journey, but Fearsome ran twice as fast as before. Almost in despair,—for six miles still lay before her,—the princess again sought refuge in a blacksmith shop. Scarcely was she seated when the ogre stamped in.

"No one but myself has come ten miles to-day," he roared. Rosalie had gone twelve, but wisely kept quiet. Fearsome was again foiled.

Swiftly she now ran to Delphi and climbed the ladder, almost exhausted. There, thirty feet in air, she must stand the final test.

"How can a maid tell whether her lover has forsaken her?" asked the Nymph.

"Pluck the topmost leaf from that oak, and cast it in the fountain," Rosalie replied.

"Right! What kind of mate does an oyster choose?"

"An oyster, of course," she answered.



"FAIRYLAND" BY R. HILL BROWN, A. G. L.

great. She bought a book. Amid a clap of thunder, the castle vanished, and Lucy found herself sitting on the lounge, clasping the fatal book.

She opened it, and there, wrought in letters of gold, appeared the words, "Be content with what you have, little though it be."

Lucy awoke with a start. It was long past dusk, and she must be getting supper. As she set the table, she thought over her strange dream; and from that time on she ceased to long for things she could not have, and became content.

THE DANCE OF THE FAIRIES.

BY MARGARET EWING (A. G. L. 12.)

(Silver Badge.)

'T was in a forest deep and green,
Where stood old, hoary, moss-grown trees,
That stretched their leafy branches out,
And joined the murmuring of the breeze;

'T was on a still, dark summer night,
When silence lay on field and town,
When sleeping flowers drooped their heads,
And the silvery moon shone coldly down;

When out of the stillness grew a sound,
A strain of elvin music sweet,
And from the green-paved forest aisles
The pattering of fairy feet.

Out of the shadows deep they came
Into a moonlit forest glen,
Where the branches formed a leafy roof,
And the moss ne'er echoed the steps of men.

Each tiny fay was richly clad
In flower-petals bright and fair,
And dewdrop diamonds gleamed and flashed
On snowy throats and shining hair.

Then, while the nodding bluebells rang,
The fairies danced till the night was done,—
Till the wan moon sank behind the hills,
And the wee stars faded one by one.

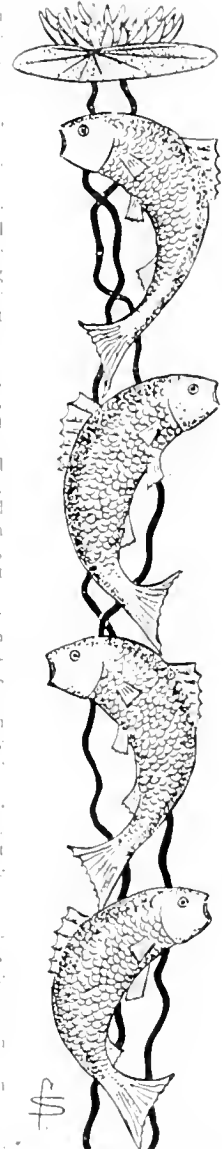

S

DEPT. OF COMMERCE,
BY ORDER OF THE SECRETARY,
AGE 15. (HONOR
MEMBER.)



"MARCH." BY KENNETH HORNER, AGE 13. (SILVER BADGE.)

"Right, again! Now, how long can true love endure?"

"Forever!" was the response.

"Name your request," said the Nymph.

"Restore Prince Charming to me, and grant us safety and happiness."

"They are yours," was the reply.

Prince Charming and Princess Rosalie now returned home, and a few days later the wedding was celebrated.

THE FAIRY LAKE.

BY CATHARINE H. STRAKER (AGE 12).

(Honor Member.)

Far from the city's endless rush,
Far from the clamor, the noise and crush,
There is a lake no man has seen,
For by it lives the fairy queen.

No motor horn 's been heard of
there,
No sorrow known, or toil, or care;
There everything is perfect bliss,
And nothing 's ever gone amiss.

The trees and shrubs are all in
flower,
There 's always sun, and ne'er a
shower,
The air is sweet, without a wind,—
A nicer place you could not find.

The waving pines, the rippling lake,
The cliffs that rise without a break,
The rocks and caves where fairies
dwell,—
Long tales of these there are to tell.

Alas! no mortal man can reach
That quiet lake and rocky beach;
For fairies guard it night and day,
To fright each human step away.



"A JUNE NIGHT" BY CAMILLA DANIELS, AGE 7.

SEVERAL hundred years before the invasion of Mexico by Cortez, there ruled in the realm of sunshine a very wise emperor, who made the following law: Every stranger who comes to the court shall be served with a fried fish. The attendants shall carefully watch the new comer, and if, after eating the fish down to the bone, he turns it over to eat the other side also, he shall be arrested and after three days hanged. But, through his imperial grace, the culprit may each day make a wish, which shall immediately be granted, provided he does not ask for his life.

There had already been more than one victim to this new law, when one day a young count appeared at the court. The noble guest was welcomed in the warmest manner, and, in accordance with the law of the emperor, a fried fish was served



"JUNE." BY RICHARD A. REDDY, AGE 17.

MOTHER'S FAIRY.

BY MARCIA HOYT (AGE 14).

A SMILING little fairy
Is around the house each
day;
She runs on errands long
and short,
Without a bit o' pay.
She minds the baby like a
nurse,
And never 's in the way.

This fairy has n't any wings,
She walks upon two feet;
She does not feed on cake
or wine,
But bread and milk doth
eat.
She 's only mama's little
one,
This fairy kind and sweet.

HOW THE COUNT WON HIS KINGDOM.

BY RAY MURRAY (AGE 13).

to him in the midst of his repast. The young nobleman relished it heartily, and after eating it down to the bone he turned over the fatal fish.

He was instantly seized by two attendants and dragged before the emperor, who ordered him to be thrown into prison.

Once in the dungeon, the youth said to the jailers: "You know that, before dying, I am entitled to three wishes. Go to the emperor, and tell him to send to me his daughter and a priest to marry us."

A more astonished man than the emperor at this insolent demand it would have been hard to find. But a sovereign's word is sacred, and after much useless trouble the king gave his consent to their marriage. The next day he had the emperor name him as his successor to the throne at his death.

On the third day the emperor came himself to the culprit and said:

"Come, make haste to tell me your last wish, for I am beginning to tire of your unreasonable demands."

"Sire," said the youth, "I have but one more wish to ask of your imperial majesty, and then I shall die content. It is to put out the eyes of all those who saw me turn over the fish."

"Very well," said the emperor; "your demand is quite natural, and does credit to your goodness of heart."

Upon which, he arrested the cupbearer.

"Z, sire!" cried the cupbearer. "I saw nothing of the kind; it was the butler."

"Seize the butler," cried the emperor, "and put out his eyes!"

But the butler declared with tears that he had seen nothing of the kind; he referred to the pantler, who referred to the head waiter, who referred to the second waiter, who referred to the third; and, in short, no one had seen the young nobleman turn over the fish.

As no evidence was to be had, the count was set free; and at the death of the emperor he himself became the ruler of Mexico.

IN SEARCH OF FAIRYLAND.

BY ALLEINE LANGFORD (AGE 16).

(Honor Member.)

"Oh, will you tell me, sir?" she asked;
 "I've hunted all the day,
 And have not found a single one,
 And now I've lost my way.

"I want to find a little elf;
 I've looked both high and low,
 But I can't see a sign of one;
 So pray, sir, do you know

"Where I can find one fast asleep,
 And would you kindly tell?
 They are not in the primrose buds
 Or in the lily's bell.

"I've hunted in the buttercups,
 And in the daisies white;
 For they must be somewhere to-day—
 I'm sure they danced last night.

"I've looked beneath the spiders' webs
 That dot the meadow green;
 For I have heard they are the tents
 Made for the fairy queen.

"So will you please to tell me where
 I'll find the elfin band?
 For I have grown so very tired
 In search of fairyland."



"ELF IN FAIRYLAND," BY ELIZABETH OTIS, AGE 17.
 (HONOR MEMBER.)

NOTE.

A number of accepted stories and poems have been crowded out of this number and will appear in later issues.

NEW CHAPTERS.

No. 798. "Merry Six." Rosa Gahn, Secretary; six members. Address, Hudson Heights, N. J.

No. 799. Helen Baxter, President; Beth Baxter, Secretary; three members. Address, 4701 Dupont Ave., Minneapolis, Minn.

No. 800. Leslie Berger, President; Wallace D. Holden, Secretary; ten members. Address, 25 Hazel St., Danville, Ill.

No. 801. "The Snowflake." Rita Collins, President; Gladys Carikum, Secretary; four members. Address, Hilerica, Mass.

No. 802. "Towanda." Ruth A. Spalding, President; Jean L. H. Lombard, Secretary; four members. Address, 22 William St., Towanda, Pa.

No. 803. Marion Jackson, President; Dorothy Dutt, Secretary; six members. Address, 525 Garland St., Flint, Mich.

No. 804. Harold White, President; Catherine Toole, Secretary; five members. Address, 245 Center St., Bangor, Me.

No. 805. "Carthage Chapter." Fifty-five members. Address, Carthage, Mo.

No. 806. "M. S. C." Hazel Schofield, President; Emma Rogers, Secretary; fifteen members. Address, New Lexington, Ohio.

No. 807. Ida Laubenstein, President; Willie Clair, Secretary; ten members. Address, Ashland, Pa.

No. 808. Margaret Spain, Secretary; ten members. Address, 34 Nassau St., Princeton, N. J.

No. 809. "Diamond H." Shida Noble, President; Muriel Fairweather, Secretary; eleven members. Address, 29 Percy Park Road, Lynemouth, Northumberland, England.

No. 810. "The Sunshine Chapter." Therese McDonnell, Secretary; four members. Address, 602 N. 17th St., Philadelphia, Pa.

No. 811. Charley E. Cole, Secretary; twenty members. Address, Middleton, Ga.

No. 812. "Abba." Alice R. Bond, President; Ruth Keaton, Secretary; thirteen members. Address, Kohala, Hawaii.

No. 813. Josephine Lanning, President; six members. Address, 2841 Eighth Ave., N. Y. City.

No. 814. "Scribblers." Rosamond Coney, President; Anna Darmitzen, Secretary; ten members. Address, 137 Radston Ave., So. Orange, N. J.

No. 815. "St. Nicholas Six." Eleanor S. Berry, President; six members. Address, 113 E. Terrace, Chattanooga, Tenn.

No. 816. Laura E. Lacy, President; Edna E. Hughes, Secretary; four members. Address, 4006 Pine St., W. Philadelphia, Pa.

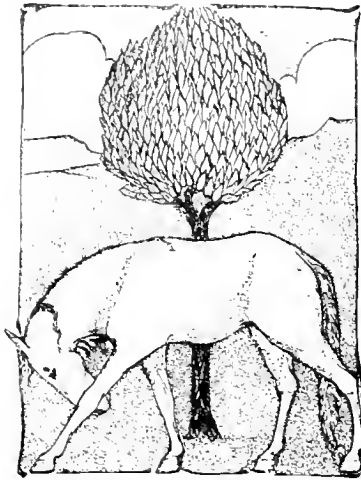

"JUNE." BY EMILY W. BROWNE, AGE 15.

THE ROLL OF HONOR.

No. 1. A list of those whose work would have been used had space permitted.

No. 2. A list of those whose work entitles them to honorable mention and encouragement.

VERSE 1.

Agnes Churchill Lacey
Nannie Clark Barr
Eleanor Myers
Wilma E. Davis
Gerald Jackson Pyle
Elizabeth Spicer
Margaret A. Brownlee
Clady's Nelson
Beatrice Washburn
S. Mildred Martin
Dorothea Thompson
Grace Le-Je Johnston
Annie Wilson Highley
Helen M. Dana
Edith Louise Smith
Agnes Alexander
Dudley Clapp
Dorothy Alderton
Katharine G. Kurz
Louisa F. Spear
Marguerite Stuart
Ruth P. Getchell
Elizabeth Morrison
Elizabeth C. Day
Helen Leslie Follans-
bee
Olga Maria Kolff
Marguerite M. Jacque
Emmeline Bradshaw
Anna C. Heffert
Margaret Mernam
Sherwood
Margaret Goldthwaite
Hester Leavenworth
Webb Vorys
Stella Benson
H. Mabel Sawyer
Helen B. Parsons
Kathleen A. Burgess
Susan Warren Wilbur

VERSE 2.

Frances Paine
Clement R. Wood
Joseph L. Dunham
Maude H. Brasie
Geneva Anderson
Wyliah Aitken
Alice Tomblor
Beatlah H. Ridgeway
Olive Mudie-Cooke

Fanny J. Walton
Mary E. Mair
Emily Rose Burt
Edward F. Sartor
Twyla A. McDowell
Elizabeth H. Critten-
den
Dorothy Nicoll
Alda Palmer
Elliot Q. Adams
Mollie M. Cossaart
Dorothy G. Gibson
Gratus B. Camp
Florence Isabel Miller
Marguerite Weed
Alta M. Lockwood
Lida S. McCague
Margaret Bennett
Jones
Frances Lubbe Ross
Edith Beatrice Avera
Alice Wells Walter
Clara Sisson
Leah H. Stock
Mason Garfield
Adolph Sparling
Dorothy Mercer
Wilbur K. Bates
Leland G. Hendricks
Alice Blaine Damosch
Elizabeth Toof
Ions Gilbert Sutherland
Rosamond H. Coney
Mary Blossom Bloss
Lois M. Cunningham
Carolyn Bulley
Corinna Long
Helen Hinds Twitchell
Julia Dorsey Munser
Josephine Ethel Swain
Maude Miller
Dorothy G. Stewart
Mary Winslow
Robert E. Naumburg
Myrtle Moore
Julia S. Ball
Dorothy Puell
Elsabeth Sears Ram-
say
Theresa S. Leshar
Constance Gardner
Marguerite Radley
Henrietta Hepburn
Matilda Canara

PROSE 2.

Edith Louise Jordan
Helen W. Purdy
Helen Schmidt
Mary Ellen Willard
Ethel Berrian
Elsie F. Weil
Ada M. Neisel
Margaret McElroy
Barbara Thrasher
Harriet Fitts
Fred Flinn
Mary E. Pidgcon
Theodora B. E. Mc-
Cormick
Madeleine Polk Taylor
Dorcas Perkins
Bertha Torchiani

PROSE 1.

Edith M. Johnson
Margaret Abbott
Helen Davenport
Perry
Freda M. Harrison
H. K. Pease
Katherine R. Polk
Rachel Bulley
Katharine J. Bailey
Margaret Dole
Lawrence Harger Doo-
little
Mary R. Paul
Mildred Bacon
Jessie May Furness
Primrose Lawrence
David Fishel
Enid H. Pendleton
Katharine A. Potter
Master B. Hodge
Mildred Eareckson
Adele d'e. Blauvelt
Jeannette Munro
Marion L. Fox
Helen Hinman
M. W. Twitchell
Helen Paul
Edith Carey Owens
Ethel Louise Knight
Grace Phelps
Clarence B. Reemeln
Frances C. Reed
Helen Semple
Ada Loeb
C. Ethelwyn Harris
Katharine M. Sher-
wood
Marie Armstrong
Constance H. Parmely
Sylvia Mary Allen
Katharine Place
Helen R. Schlesinger
Anna M. Kress
Elsa Loeber
Helen Wheeler
Eleanor Granger
George Switzer
Helen W. Irvin

Florence Campola
Dorothy St. John Mid-
may
Sarah P. Madill
Elizabeth G. Beale
Elnor L. P. Lyon
Helen Wyman
Viola Irene Teepe
Margaret Lyon Smith
Nance Daniels
Alice Wangerheim
Josephine Freund
Dorothy Jefferson
Eleanor Johnson
Sam W. Lambert
E. Babette Deutsch
Frances Moyer Ross
Sterling A. Wood, Jr.
Marguerite Wessel
Mary Taft Atwater
Clarence Sears Kates,
Jr.

Mary J. Kelley
Helen Van Dyck
Christian Vranz
Abigail E. Jenner
Dorothy E. Wallace
Susan J. Appleton
Olive Brogan
Luther E. Ellsworth,
Jr.
Carlton Montaiye
Clara Allen
Florence Rosalind
Spring
Marjorie Bailey
Georgia Hurlin
Irene Bowen
Katharine Norton
Gertrude Amory
Pauline Hamilton
Dorothy S. McIlwraith
Marjorie Butler Sump-
ter

Elizabeth Lewis
Lelia E. Tupper
Marguerite Brewster
Inogene Avis Tatum
Margaret E. Lanmer
Mary Pemberton
Nourse
Frances Jeffery
Gladys Harrison
Eleanor B. Southworth
Jeannette Langhaar
Elsie Alexander
Elizabeth L. Clarke
Sibyl H. Wright
Buford Bryce
Margaret F. Grant
Robert Wood
Wendell Holmes Gar-
rison
Alma H. Liechty
Helen N. Macdonald
Willie S. Allen
Marjorie G. Lachmund
Elnor Townsend
Eleanor E. Wild
Ruth P. Cornwall
Marian T. Whitford
Kathie Macphail
Mary Fuller
Marta Cardinal y Ry-
jals
Evelyn M. Mactavish
Elsa Clark
Marian P. Van Buren
Eric Hodge Bounder-
vean
Annette Evans
Therese Born
Caroline Porter
Bruce Simonds
Duncan McGregor
Vincent Imbrie
Beryl Morse
Oswald Brewster
Virginia Merritt
Catherine E. Jackson

DRAWINGS 1.

Shirley Alice Willis
Margaret Dobson
Elbert Baldwin
Manuela von Heri-
goven
Bryden Pease
Robert Edmund Jones
Bessie T. Griffith
Lois D. Wilcox
Seth Harrison Gurnee
Linda Matthew-Hale
Scarritt
Margery Brad-haw
John Andrew Ross
Florence Sherk
John D. Butler
Kate Sprague De Wolf
Elizabeth Morton
Margaret Winthrop
Frank Lister
Marie Atkinson
Guadalupe Alvarez

Katharine Dulce
Bella Harbour
Alice C. Lloyd
Raymond E. Cox
Bertha C. Larrabee

DRAWINGS 2.

Josephine Bell
Georgina Marion Wood
Rita Wood
Charles Valles
Florence Murdoch
Hugh Spencer
Laurence J. Young
Charlotte Waugh
Isadore Douglas
Elmer Rampion
Melville C. Levey
Carola Keller
Eleanor I. Town
Ben Roth
Bion Barnett
Neva Kanawaga
Mark Curtis Kinney
Sarah McDavitt
Paul Sheaffer
Edith Prindeville
Jennie S. Fernald
Beth May
Elsie A. Seeger
Fred L. Pindy
Maysie Regan
Leslie Crouch
Fannie Tutwiler
Helen O. C. Brown
Beatrice Andrews
Anna Zucker
Marjone L. Keasbey
Archibald MacKinnon
Maude G. Barton
Mary McKim Wilde
Isabel Howell
Rena Kellner
Carma Eaglesfield
Elizabeth Robinson
Lauren Ford
Elizabeth E. Thomas
Sue Melame Justice
Rita Ward
Pauline Robinson
Vera Demens
Wilma Cory
Edna Behre
Dorothy Sturgis
Mildred Andrus
Mary Powell
Lena Gertrude Towsley
Gracie Westbrooks
Walter J. Norman
Mary A. Jones
Frances Ward
Mabel Updegraff
John Wetzel
Helen Drew
Frances Powell
Bertha V. Sanders
Dorothea Keasbey
Delphina L. Hammer
John Willis Love
Leila V. Remnitz
Dorothy G. Hamilton
Walter Burton Nourse
Dorothy Smith
Lois Treadwell
Frances Jackson
Edward Osgood
Bradley Middlebrook
Flora Sheen
Jean Byers
Minabell Summy
Gretchen Smith
Charlotte St. George
Nourse
Katharine Van Buskirk
James Rowland Joiner
Anna Smith
Theresa R. Robbins
Eleanor D. Eldsgett
Lorenzo Hamilton
Helen May Baker
Ruth Brockington
Rebecca Wyse

Molte Bullock
Margaret P. Merrill
Mabel Alvarez
M. A. Harrison
Alice Noble
Elizabeth Stockton
Grace Noble
Myron C. Nutting
Muriel C. Evans

PHOTOGRAPHS 1.

Alfred D. Karr
Katharine Ordway
Donald Jackson
Cornelius Cannon
Muriel Foster
Harry F. Cornwall
Mary A. Woods
Paul Wormser
E. S. McCawley
Gwendolen Matthew-
Hale Scarritt
Eaton Conger Edwards
Roland Redmond
Dorothy Wormser

PHOTOGRAPHS 2.

Foster Townsend
Helen R. Power
Emily Yocum Brown-
back
Alice K. Bushnell
Irene F. Wetmore
Florence R. T. Smith
Henry Morgan Brooks
Constance Taylor
Caroline Dudley
Hilliard Comstock
Eric Cushman
Marjorie Miller
Walter Byrne
Gertrude M. Howland
Sheila St. John
Dorothy Hall
Hamilton Howland
Hoppin
Willis Fay
Marjorie Pope
Rutherford H. Platt, Jr.
Phyllis Eaton
Dorothy Eaton
Warren Sullivan
Evangeline G.
Coombes
Amy Ehot Mayo

PUZZLES 1.

Lawrence Phelps
Scott Sterling
Benjamin Berry, Jr.
Weightman Edwards
Erwin Janowitz
Dorothy Marcus
Harry I. Tiffany
Agnes R. Lane
Mabel Howe
Agnes M. Fishel
Anita Hackbusch
Oris Zielsdorf
Edna Krouse
Helen Farrington
Burt H. Smith
Dorothy Stabler
Fred Stedman
Nettie Barnwell
Margaret Greenshields
Alfred Janowitz
Ellsworth Gilbert
Margaret B. Richard-
son
George G. Chapin
Beatrice Reynolds
Laurence E. Whitaker
John Orth

PUZZLES 2.

Arthur C. Hoppin
Dorothy E. Bates
George Wehber
Thorne, Jr.
James Burgess Diggs
Gertrude C. Valentine

LEAGUE LETTERS.

BOSTON, MASS.
MY DEAR ST. NICHOLAS: Thank you ever so much for the gold badge. It is a perfect beauty, and I feel so proud of it! Perhaps you can imagine how surprised I was when one of my friends came in to congratulate me for the prize; because, you see, I had not received my December number yet, and so did not know anything about it.

I have been trying for a prize ever since the League began, and until this fall—when I got my name in the roll of honor—I never got anything. It proves the saying that "if at first you don't succeed, try, try again."

Thanking you again for the badge, I remain always,

Your faithful reader,
ANNA LORRAINE WASHBURN.

DEAR ST. NICHOLAS: Thank you ever so much for my badge. I lost it I woke up in the night, and being afraid it might in some way be lost got up to make sure it was there. My friends all admire it very much.

Will you please have "An Original Fairy Story" in some competition? I think it would be great fun.

Your grateful friend and faithful reader,
LOUISE ROBERTS.

P. S. I am very much interested in "Queen Zita of Ex."

CENTRAL PARK, N. Y.

DEAR ST. NICHOLAS: My badge came last night and I am delighted with it. It is a great encouragement to me, and I shall try hard to win a gold badge next.

I have only been taking the magazine regularly since last winter, and I think it is splendid. I liked "Elmor Arden, Royalist" very much, and I am sorry that "A Comedy in Wax" is finished, for I thought it was very good, especially the Shakspeian quotations. I am a little English girl, and was born in London, but we came to America when I was only four years old, and have lived here most of the time since then. I am very fond of reading, and writing compositions, and I hope to be an author when I grow up, so I am very much interested in the League competitions. And now I must close my letter.

Your loving reader,
DOROTHY RULES.

SOUTHAMPTON, ENGLAND.

DEAR ST. NICHOLAS: Please can you spare a little place to print this letter, because if you can't I am afraid the other League members will think I am getting lazy, as I shall not be able to send many contributions now. I am just ten, and have begun to go to school. I have never been before, and have to join a class with girls older than I am, so the lessons seem very long and take up every bit of the time that is not used for coming and going. The school is a long way from here, and the cars do not go in that direction. I have been for three weeks. Eight mistresses teach in my class and I like every one of them, and the lessons are lovely, only I do wish I could write more quickly. I shall always want to do something for ST. NICHOLAS, and shall try directly I have time. I want to send a drawing of Henry V's cradle.

Your loving friend,

ELSA B. CARLTON CLARK.

BARCELONA, SPAIN.

DEAR ST. NICHOLAS: I have had you for three years and I like you very much.

I am a little Spanish girl and I live in Barcelona.

It is only three years since I began to learn English, and as soon as I can I will try for one of your competitions.

It has given me great pleasure to see in the October number that my friend Zenobia Camprubi has won the gold badge, and through you I congratulate her.

The tales I like best are "Elmor Arden, Royalist" and "The Comedy in Wax."

Wishing you many years of life, I remain your faithful reader and League member,

MARTA GARDENAT (age 12).

Appreciative and interesting letters have been received from Mary Hunter, Alice Knowles, Mary Wood, Helen R. Sampson, Paul Twitchell, Helen Stroud, Dorothy Ruthertford, Janet Rankin, Imogene A. Tatum, Gertrude Cott, Fanny S. Mitchell, Margaret Bull, Seward C. Simons, Elizabeth Curtis, Elizabeth Palmer Lopez, Helen Twitchell, H. Ernest Bell, Philip John Sexton, Dorris Jenney, Anna Clark Buchanan, Marion van Buren, Elizabeth Toof, Edith Louise Smith, Dorothy Candee, and Ynez A. Wingerter.

NOTICE.

SUGGESTIONS for League subjects are always welcomed by the editor.

PRIZE COMPETITION No. 69.

THE St. Nicholas League awards gold and silver badges each month for the best poems, stories, drawings, photographs, puzzles, and puzzle-answers.

Also cash prizes of five dollars each to gold-badge winners who shall again win first place. This does not include "Wild Animal and Bird Photograph" prize-winners.

Competition No. 69 will close **June 25** (for foreign members **June 30**). The awards will be announced and prize contributions published in ST. NICHOLAS for **September**.

Verse. To contain not more than twenty-four lines. Title: to contain the word "Summer."

Prose. Story, article, or play of not more than four hundred words. Subject, "A Strange Adventure."

Photograph. Any size, mounted or unmounted; no blue prints or negatives. Subject, "The Waterfall."

Drawing. India ink, very black writing-ink, or wash (not color), interior or exterior. Two subjects, "A Study of Flowers" (from life) and a Heading or Tail-piece for September.

Puzzle. Any sort, but must be accompanied by the answer in full, and must be indorsed.

Puzzle-answers. Best, neatest, and most complete set of answers to puzzles in this issue of ST. NICHOLAS. Must be indorsed.

Wild Animal or Bird Photograph. To encourage the pursuing of game with a camera instead of a gun. For the best photograph of a wild animal or bird taken *in its natural home*: *First Prize*, five dollars and League gold badge. *Second Prize*, three dollars and League gold badge. *Third Prize*, League gold badge.

RULES.

ANY reader of ST. NICHOLAS, whether a subscriber or not, is entitled to League membership, and a League badge and leaflet, which will be sent on application.

Every contribution, of whatever kind, *must* bear the name, age, and address of the sender, and be indorsed as "original" by parent, teacher, or guardian, *who must be concerned beyond doubt that the contribution is not copied*, but wholly the work and idea of the sender. If prose, the number of words should also be added. These things must not be on a separate sheet, but *on the contribution itself*—if a manuscript, on the upper margin; if a picture, *on the margin or back*. Write or draw on *one side of the paper only*. A contributor may send but one contribution a month—not one of each kind, but one only. Address:

The St. Nicholas League,
Union Square,
New York.



"FAIRYLAND." BY KATHLEEN BUCHANAN, AGE 10.



"JUNE" BY F. BURBANK, AGE 12.

BOOKS AND READING.

A VACATION BOOK. WHEN it comes to packing your trunk for your vacation, do not forget the "book for a rainy day." There are now so many small and compact editions of good authors that it would be a pity to leave all your library at home. Sir Walter Scott's *Waverley Novels* are issued in several pocket editions, and you will find it difficult to make a better choice than one of these. He is so wholesome and bracing, so fond of fresh air and the country, that his stories read best in the woods or on the lake, or (before all) in the mountains. "Rob Roy," or "Waverley," or "Anne of Geierstein," or "The Fair Maid of Perth" will gladly insure you against dullness, though there is nothing but the printed page to amuse you for hours.

ANOTHER VACATION HINT. IF you have some duplicates of books you are fond of re-reading, take one of these with you to the country, and it may be you will find an opportunity to leave it with an appreciative friend who has not read it. Then you will bestow a kindness, and make room on your shelves for some new friend in covers.

"ROBINSON CRUSOE" AS A TEACHER. THERE are a large number of stories that are now considered "for young people," but were originally written for grown-up readers—such as "Robinson Crusoe" and "Gulliver's Travels." They are so good as stories that readers would not wait until they were old enough to understand the deeper purposes of their authors: and yet there is little doubt the philosophy and learning in them were intentional. "Robinson Crusoe," for example, has often been commended as a very fine set of studies in political economy; and yet the goat, the parrot, the savages, the footprint, and the little fort in the rocks are so interesting that few care so much for the second part, after the island is settled and the real problems begin. Even the best fairy-stories are often no more than old fables that once were meant to teach serious and important lessons; but in many cases the lessons have slipped away, leaving only the

sweetening added to make the plain truths more palatable. Lessons can be taught in so many other ways, and really good stories are rare. Æsop's fables are examples of the old method of teaching great truths by simple stories, and they have not been greatly changed from their earliest forms. La Fontaine expanded them into poems, it is true, but the simpler fables themselves are the better known.

THE FIVE CITIES. RUSKIN considered that there were five great cities whose history should be learned by every fairly educated boy and girl. He named Athens, Rome, Venice, Florence, London; adding that the history of London included, or at least compelled in parallel study, some knowledge of the history of Paris. We are not compelled to stop with these even if we admit their great importance, but may add a German city and an American, to say nothing of Jerusalem, Alexandria, and Babylon or Nineveh. Surely that will be enough.

Indeed, to make a beginning, we Americans might do worse than do some reading about London, one of the most interesting localities on the surface of our round earth, and the place of all others to help one to understand English Literature. "Walks in London," by Hare, or Besant's "London," will start you on a course of interesting work that will last throughout your life. And if you are fortunate enough to visit the city, how much more you will see of it!

FICTION AND FACT. TWO or three young girls formed a little circle for sewing and reading together; each one would read aloud, in turn, while the others worked. At first they read fiction, but they decided one day to try something else, and happened to choose French history. Now, to read aloud any one history must become a little monotonous; so these wise young ladies made up their minds to use the history only as a starting-point, or guide, and to read upon such topics as were suggested by the main narrative.

For instance, reaching the age of Charles the Great, they resolved to know something about

Charlemagne's times, of his court, and of the knights who fought his battles. When they came to the feudal system, they laid the history aside until they became acquainted with that great society which grew up around the strongholds of the nobles. In this way the history became not only clear but very interesting — and they all declare that the pleasures of fiction do not compare with the charms of truth.

HOW READING HELPS. A YOUNG correspondent who has been kind enough to write a letter of thanks for some aid received from suggestions in this department says that she finds much pleasure in securing pictures of her favorite "book-friends" to hang in her room. "Sir Galahad" she gives the place of honor. Such pictures are helpful in making book-characters more real, and the books return the service by giving the portraits greater interest. Indeed, all work helps one to understand books better, and books help one to do good work. The idea that a reader is a dreamer, an unpractical, useless being in real life, can apply only to those who read idly and without thought stories written without purpose — and that, without doubt, is mere laziness.

NATURE STUDY. THERE is more than one way of studying nature. The way that is most commonly understood by those using the phrase is that of the student of science, who observes the living creatures and thus adds to his knowledge. But the lover of books may find in his outdoor rambles much to help him in understanding his reading. Nearly all the poets find sentiments as well as facts in nature, and in order to appreciate the best poetry it is necessary to sympathize with their love of outdoors.

During the coming summer you might select a good piece of verse descriptive of each month, and, bearing it in mind, learn to see the realities that the poet has put into his lines. And there is no reason why the same advice should not be widened to take in the whole year.

NOT BAD, ONLY POOR. No doubt many a boy feels that his father or his mother unjustly condemns story-books he finds good reading. It is best to admit at once that there is usually little or no harm in the ordinary juvenile books; even the poorer ones are often harmless enough. But when your kind uncle

remarks, "I should n't think you 'd waste time over that book," he is likely to mean that you are giving valuable time to valueless reading.

It is worth while to find out the best; and the finding of good reading on almost any subject is to-day an easy matter. If you will let us know what topics interest you, we can give you in this department lists of books that you will enjoy, and that will do you good. If you read second-rate books, you will be led to think in a commonplace way.

POETRY AGAIN. WE should not be surprised if some young readers of this department should feel that there was a large proportion of its space given to recommending the reading of the poets. Possibly it is not necessary; but one who has found great pleasure in the poetical side of literature is anxious that young readers should not make the mistake of thinking poetry less attractive than prose. The trouble with those who find poetry dull is usually in the choice of the wrong poems for their moods. Much verse depends very largely for its effect on the mood of the reader; what will seem sublime at one time may fail to affect you at another, and humor of the most delicate character is lost upon a sullen or an indifferent reader. But in order to make an intelligent choice one must know enough about poetry to furnish variety from which to select. At one time you will enjoy a ballad by Browning or Macaulay, at another will prefer one of the "Tales of a Wayside Inn"; Wordsworth suits one mood, Campbell another, while Scott or Emerson may be preferred on some days. When, however, you are suited, no reading will bring you so keen a delight.

MOTHER GOOSE GEOGRAPHY. THE old "Banbury Cross" familiar from the Mother Goose rhyme was a real cross in the English town of Banbury. For a long time it was in ruined condition, but was restored some twenty years ago, possibly because tourists would ask to see it. But the "Old Lady" upon the white horse, with all her bells and rings, is gone forever, music and all. "Primrose Hill" is another real locality, being in London near Regent's Park. "St. Ives," on the road *from* which "seven wives" were met, is the town where Oliver Cromwell passed five years in farming.

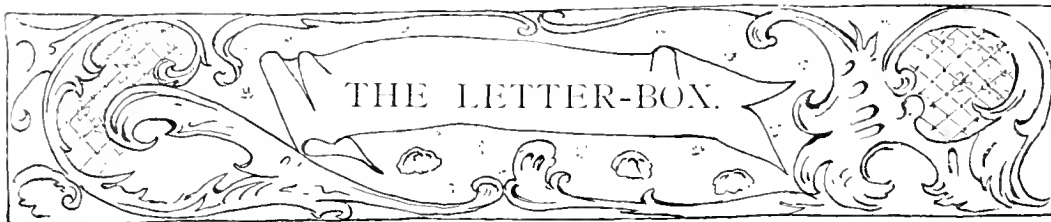

WORCESTER, MASS.

MY DEAR ST. NICHOLAS: This morning I went out expecting to have some fun, but the snow was so deep that I did not get any fun at all.

I have never written a letter to the Letter-box, and I have never got any of the League badges; but I hope soon to do such good work that I may be successful.

I like the ST. NICHOLAS very much, and I like "Queen Zizi of Ix" too.

I have one of those big Chinese fishes that wave like flags in the air. I had mine out last spring, but I could not find a pole to put it on; so I got a short pole and put it in the top of one of our trees and tied a string to the end of its tail and tied it to the ground, so when the wind came up I could give the string a pull and the fish would wave.

Very truly yours,
NEWTON P. DARLING (age 8).

BURRADOO, NEW SOUTH WALES.

MY DEAR ST. NICHOLAS: I do wish you had a post-card column, as I'm a very keen collector. I have sent nearly forty post-cards away since April, but have had no answers yet, and English mail-day is great excitement to us. I have three sisters, two of whom also collect, so there are three collecting in this house. If you print this letter, I hope that some of your readers who collect post-cards will exchange with me. I only want views. Burradoo is not a town, but a number of summer residences of Sydney people who come up in the summer.

I can ride, but have not a horse at present. Last Friday, Saturday, Sunday, and Monday we had sixteen inches of rain, and one of our ponies got the cramp and could not move. We have five cats, and three puppies, and two horses. The cows belong to the place, so do two ponies. Mother is in Sydney at present.

Good-by now, with best wishes from
MARGERIE INNES NOAD.

PORTLAND, ORE.

DEAR ST. NICHOLAS: I am nine years old, and I have taken you for three years, but this is the first letter I have written to you. When my mother was a little girl she took you from the first year you were printed till she was eighteen. She saved lots of the volumes, and we can enjoy the stories that are more than twenty-five years old. And they are fine stories, too.

My little brother and I have six ponies and two dogs. We keep them on our ranch in Montana, where we go in the summer.

Your constant reader,
CHARLEY LARRABEL.

IOWA CITY, IOWA.

DEAR ST. NICHOLAS: I received the badge and certificate, and I am glad to be a member of the League.

I want to tell you about some plays some of my friends and I are having. One of the girls, who is eleven years

old, fixed "Elinor Arden" into a play. We acted it in a barn which we had decorated and fixed with a stage. It made a very nice play. I will send you one of our handbills. We got a dollar and fifteen cents from the tickets, which were five cents apiece.

A N I N C I D E N T
i n t h e L i f e o f
E L I N O R A R D E N

A N E W P L A Y
B r i l l i a n t a n d T h r i l l i n g

a n d P r e s e n t e d b y a n
A L L S T A R C A S T

Captain Lawrence
Helen Loos

Geoffrey Lawrence
Cristabel Loos

ELINOR ARDEN
ALICE LOOS

Princess, Henrietta Anne
Gwendolyn McClain

Lady Lindhurst
Ethel Gordon

Nell Lawrence
Helen McChesney

at the

Saturday October Twelfth
Three o'clock P.M.

Dress Circle Five Cents

and fifteen cents from the tickets, which were five cents apiece.

Now we are going to act "Princess Madge," and perhaps "Mrs. Tubbs's Telegram."

I hope you will have some more stories which we can act.

Your loving reader,
ETHEL RUTH
GORDON.

DEAR ST. NICHOLAS: This is your second year with me, and I hope it will not be the last. You were a Christmas present from my Aunt Fannie in New York. I like the Letter-box very much, and always look at it. I live in Greenwich, Connecticut, and I have four pets. They are three guinea-pigs and a cat. We have a fine place to skate here, and I always go when it is good. Wish-

ing you success,
Your interested reader,
DWIGHT BOWLES, JR.
(age 10).

BRIGHTON, MASS.

DEAR ST. NICHOLAS: I want to write and tell you how much I have enjoyed your article of "How to Study Pictures."

I belong to an art club, and am secretary of it. Every week we take up a new artist and write about him in books which we have, and if there is anything about him in ST. NICHOLAS, the president reads it to us.

I think I will stop now, as I don't want this letter to be too long. Ever your devoted reader,

GWENDOLEN TUGMAN.

Interesting letters, which lack of space prevents our printing, have also been received from Philip P. Patout, Aline Whiteman, Melville B. Calvert, Gertrude Beer, Enid Foote, John Ely Moore (Korea), Josephine Holden, Ruth Horney, Dorothea Spottiswoode Dandridge, Edith Philips, and Eva Lucile Foster.

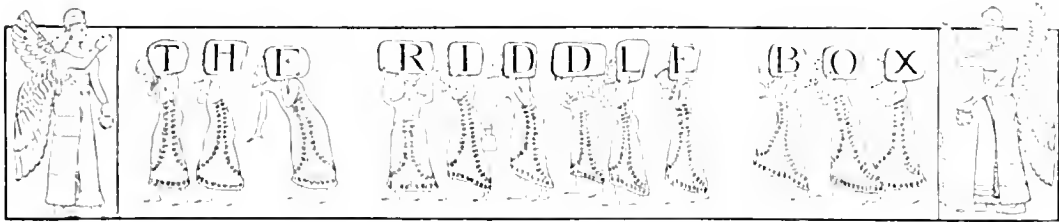

ANSWERS TO PUZZLES IN THE MAY NUMBER.

CONCEALED NAMES. 1. Mary. 2. Winifred. 3. Alice. 4. Helen. 5. Dora. 6. Edith. 7. Amy. 8. Frances.

BEHEALINGS AND CERTAININGS. George Washington. 1. Change, hang. 2. S-lates, tale. 3. Corns-r, Nero. 4. Grapes, pear. 5. B-rings, ring. 6. P-erson, case. 7. E-lbow-s, blow. 8. C-ante-r, Etna. 9. A-n-swer, news. 10. A-r-thur, Ruth. 11. L-ively, Levi. 12. F-rien-d, rein. 13. E-n-gag-e, gang. 14. V-astly, salt. 15. S-hore-s, hero. 16. A-corn-s, corn.

A CARGO OF TEA. 1. Table. 2. Trade. 3. T-ill. 4. Tingle. 5. T-ool. 6. T-rain. 7. T-wine. 8. T-witch. 9. T-ire. 10. T-art. 11. T-reason.

TO OUR PUZZLERS: Answers, to be acknowledged in the magazine, must be received not later than the 15th of each month, and should be addressed to ST. NICHOLAS Riddle-box, care of THE CENTURY CO., 33 East Seventeenth St., New York City.

ANSWERS TO ALL THE PUZZLES IN THE MARCH NUMBER were received, before March 15th, from "Alil and Adi"—Jo and I—Katherine B. Carter—Harriet Bingham—Florence Du Bois—William Bud Hart—Warren C. Waite—"Duluth"—Marguerite Hyde—Helen Hamilton Stroud—J. Alfred Lynd—C. Anthony—Paul R. Deschere—Alice D. Karr—Elizabeth Morss—Eugenie Hollister—Charles I. Sherman—Olga Lee—Jessie W. Cliton—Grace Haren—Mary E. Askew—"Chuck"—Bessie Sweet Gallup—Miriam Wendle—Mildred C. Jones—Elizabeth D. Lord—Dorothy Rutherford—Laura S. Dow—Elizabeth Delo—Eleanor Wyman—Lillian Jackson.

ANSWERS TO PUZZLES IN THE MARCH NUMBER were received, before March 15th, from Caroline Ray Servin, 8—R. Muchmore, 1—I. Shapiro, 1—M. Kahn, 1—H. Winn, 1—William H. Bartlett, 8—"Girls at 726," 7—Marion Smith, 8—Ella Sands, 8—Frank M. Walling, 5—Leonie Nathan, 8—E. Fox, 1—Elizabeth E. Lord, 4—A. Pennington, 1—"Microbia," 8—J. P. Harvey, 1—Ellen S. Brewer, 8—John Farr Simons, 8—B. Williams, 1—B. H. Smith, 1—Helen and Evelyn, 4—"St. Gabriel's Chapter," 7—Ray S. Arne, 1—Andree Mante, 3.

ZIGZAG.

(Silver Badge, St. Nicholas League Competition.)

WHEN the following words have been rightly guessed, and written one below another, the zigzag (beginning at the upper left-hand letter) will spell a place of enchantment.

CROSS-WORDS: 1. Severe cold. 2. Imagination. 3. To change. 4. Covered with hair. 5. An imaginary being. 6. Happening every twenty-four hours. 7. To browse. 8. Without sense. 9. Twelve.

GLADYS RICHARDSON.

SQUARES AND DIAMONDS.

(Gold Badge, St. Nicholas League Competition.)

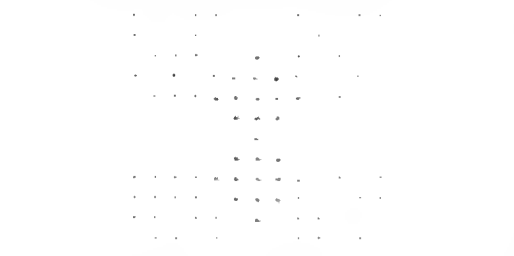

I. UPPER LEFT-HAND SQUARE: 1. Trouble-some winged insects. 2. A cavity in a wall. 3. Pungent. 4. An object. 5. Coarse grass growing in swamps.

II. UPPER RIGHT-HAND SQUARE: 1. A fruit of southern Europe. 2. Cloth made of flax. 3. Sluggish. 4. Poetry. 5. To go in.

III. UPPER DIAMOND: 1. In League. 2. An emmet. 3. To follow. 4. A small cask. 5. In League.

IV. LOWER DIAMOND: 1. In League. 2. Useful

ILLUSTRATED NUMERICAL ENIGMA. At a round table there is no dispute of place.

CONNECTED SQUARES. I. 1. Cover. 2. Olive. 3. Vices. 4. Event. 5. Rests. II. 1. Leave. 2. Elbow. 3. Abate. 4. Water. 5. Ewers. III. 1. Spade. 2. Purrs. 3. Arras. 4. Drama. 5. Essay. IV. 1. Hagne. 2. Agent. 3. Genio. 4. Union. 5. Erons. V. 1. Yells. 2. Equal. 3. Lucre. 4. Large. 5. Sleet.

CHARADE. Pig-men t

ANAGRAM. William Ewart Gladstone.

to lumbermen. 3. Proscription. 4. A tree. 5. In League.

V. LOWER LEFT-HAND SQUARE: 1. A tree. 2. Benefit. 3. Laid over with solid material. 4. Sovereign. 5. A senior.

VI. LOWER RIGHT-HAND SQUARE: 1. A number. 2. A sluggard. 3. A dazzling light. 4. A wading bird. 5. Tendency.

LESLIE V. SPENCER.

TRIPLE BEHEADINGS.

1. TRIPLY behead a small pin on which thread is wound in making lace, and leave a large box for coal. 2. Triply behead a catastrophe, and leave a flower. 3. Triply behead the flesh of sheep, and leave a weight. 4. Triply behead an instrument used in mowing, and leave an article. 5. Triply behead a wreath, and leave to ashore. 6. Triply behead to rely upon, and leave the extremity. 7. Triply behead junction, and leave over. 8. Triply behead greedy, and leave a water animal. 9. Triply behead to obtain, and leave a remedy. 10. Triply behead an inclosure containing fruit-trees, and leave difficult. 11. Triply behead a body of officers for maintaining order, and leave a frozen fluid. 12. Triply behead a square of linen formerly worn by women on the head, and leave a head man. 13. Triply behead a large fowl, and leave part of a lock. 14. Triply behead fealty, and leave epoch. 15. Triply behead to discharge, and leave to omit. 16. Triply behead the end, and leave a beverage. 17. Triply behead the goddess of love, and leave a pronoun. 18. Triply behead sweet-smelling, and leave to bestow. 19. Triply behead an assumed name, and leave like.

When the words have been rightly beheaded, the initials of the remaining words will spell a great event which happened in September, 1803.

MARY E. DUNBAR (League Member).

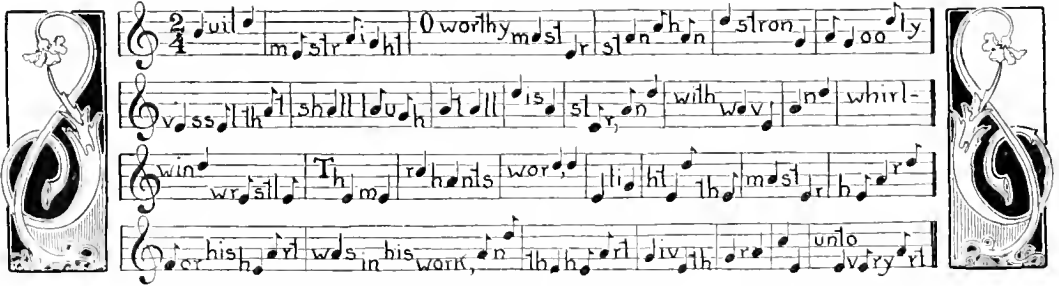

ILLUSTRATED MUSICAL PUZZLE.

How many can find, in the above lines, two verses from a famous poem?

Designed by ISABEL WEAVER (age 10).

ENIGMA.

(Silver Badge, St. Nicholas League Competition.)

M
E

Who can find the name of a flower, enigmatically expressed, in the above letters?

MYRON K. BARRETT (age 9).

ALLITERATIONS.

SUPPLY all the words of a line with the same initial letter.

*ober *ally's *ewing *eams;
*apper *avid *awdling *reams;
*houghtful *hisbe's *hinking *hemes.

*anny *urnishes *ree *ares;
*retty *olly *ickles *ears;
*illy *oxes *arney's *cars.

*reely *ilbert *athers *old;
*areless *arrie *atches *old;
*miling *tella *hould n't *cold.

*uiet *uincy *uickly *uaffs;
*azy *eonard *eaning *aughs;
*heerful *harley *huckling *haffs.

*radley's *ringing *uilding *ricks;
*usan *ibley's *aving *ix;
*essa *eaches *ommy *ricks.

DELIA HART STONF.

DOUBLE BEHEADINGS AND CURTAILINGS.

(Gold Badge, St. Nicholas League Competition.)

1. Doubly behead and curtail one who believes, transpose the remaining letters, and make base.
2. Doubly behead and curtail a certain plant which glistens, transpose, and make colorless.
3. Doubly behead and curtail to fail of its purpose, transpose, and make common vehicles.
4. Doubly behead and curtail a climbing plant, transpose, and make a companion.
5. Doubly behead and curtail the utmost points, transpose, and make a period of time.
6. Doubly behead and curtail a boundary, transpose, and make particular.
7. Doubly behead and curtail wind-flowers, transpose, and make a sign.
8. Doubly behead and curtail an ambassador, trans-

pose, and make an abbreviation meaning the present month.

When the new words have been written one below another, take the first letter of the first word, the second letter of the second word, the first of the third, the second of the fourth, and so on. This zigzag will spell something which comes with the summer.

ELIZABETH BEAL BERRY.

REVERSIBLE SQUARES.

1	.	2	.	3
.
4	.	5	.	6
.
7	.	8	.	9

FROM 1 to 2, the face of a clock; from 2 to 1, deposited; from 2 to 3, a province of Spain; from 3 to 2, a name for Christmas; from 1 to 4, a name for Dordrecht; from 4 to 1, walked on; from 2 to 5, an artificial water-trench; from 5 to 2, a Chinese coin; from 3 to 6, the upper part of a glacier; from 6 to 3, level; from 4 to 5, a civil wrong or injury; from 5 to 4, to jog; from 5 to 6, duration; from 6 to 5, to send forth; from 4 to 7, sesame; from 7 to 4, the European pollock; from 5 to 8, flood; from 8 to 5, to prepare for publication; from 6 to 9, the god of love; from 9 to 6, painful; from 7 to 8, to subsist; from 8 to 7, wicked; from 8 to 9, augments; from 9 to 8, an old word meaning "sick."

ROGER WILLIAMS (League Member).

CONCEALED WORD-SQUARE.

ONE word is concealed in each couplet.

1. An extra cedar you must get;
We've time to trim this corner yet.
2. The seats are moved into the hall;
They're high and low, and large and small.
3. Sam uses quite a space that might
Be ours for tables here to-night.
4. His office might be called, I'm sure,
A San Francisco sinecure.
5. His last typewritten letter had
Eleven errors — that was bad.
6. But his desertion we'll not mind;
Enough there are for work inclined.

HELEN A. SIBLEY.

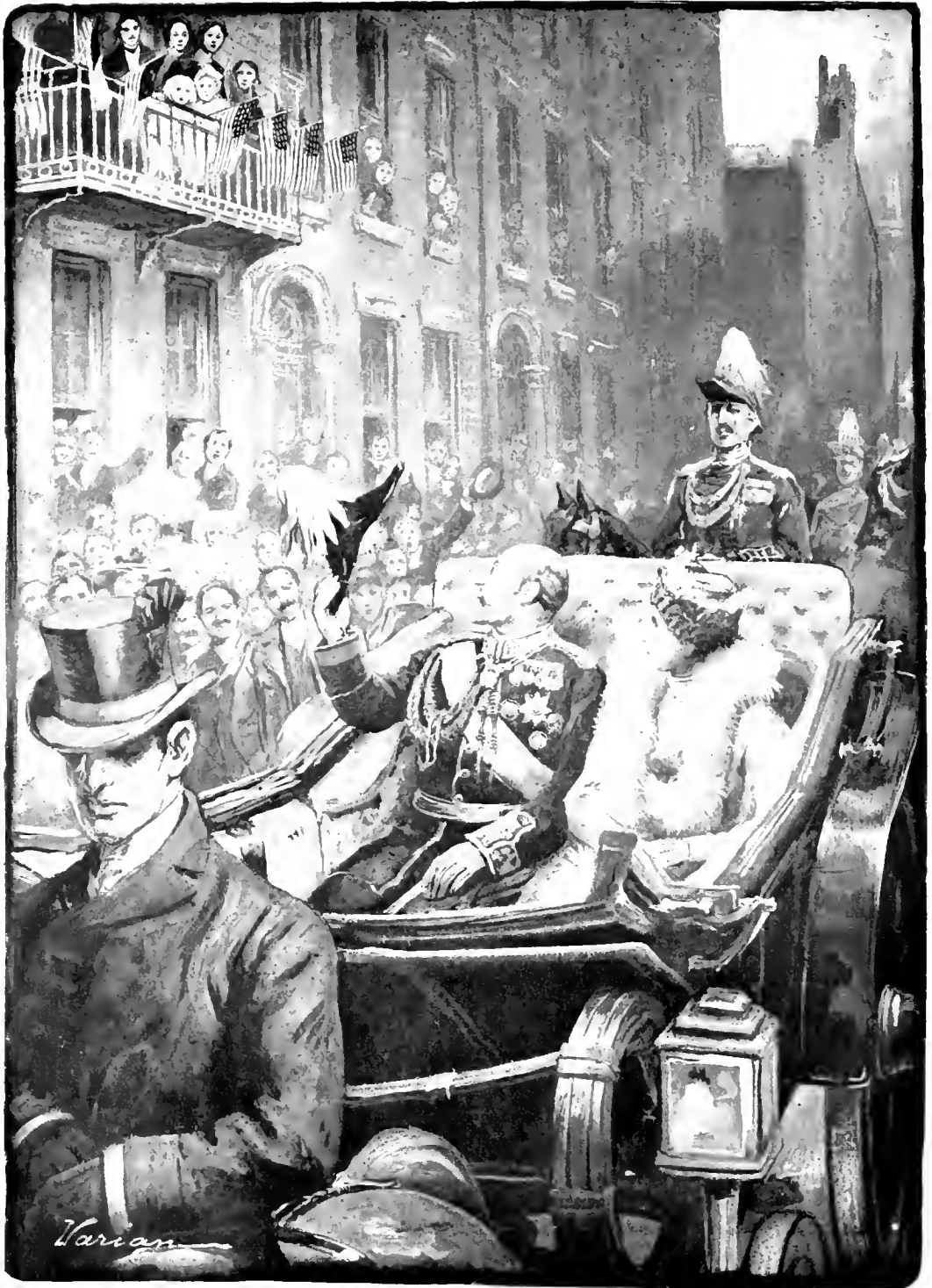

HOW TEDDY SAW THE KING.

(1901)

ST. NICHOLAS.

VOL. XXXII.

JULY, 1905.

NO. 9.

HOW TEDDY SAW THE KING.

(A Fourth-of-July Story.)

BY DOROTHY BROOKS.

TEDDY was—I don't like to say cross, but very disconsolate as he sat on the small balcony and kicked its iron railing that sunny morning. Perhaps you will say, when I tell you all about it, that he had a shadow of an excuse.

Had n't he been dragged away from school, and home, and native land, to travel with mama and two of her friends away over the ocean to Europe?

"Europe! What is the good of Europe, anyway!" said the lonely and patriotic youngster to himself.

Of course he knew that the only reason mama took him was because there was no one with whom she could well leave him.

The voyage across had not been so dull as he expected it to be; for, as his mother and her friends were not feeling very well, they kept to their state-rooms most of the time, and Master Teddy followed his own sweet will, which always suited him perfectly.

He made friends with the captain, the purser, and the doctor; he investigated the ship from the captain's bridge to the engine-room; he penetrated to the steerage, and became very friendly with several good-natured Irishmen returning to their native shores.

Best of all, many of the ladies on board had candy and other delicacies, which had been

parting gifts, but which, in the present condition of old Ocean, they could n't possibly eat; and Teddy went the rounds every morning, knocking at the state-room doors and inquiring:

"Do you feel better to-day, Mrs. Smith?"

And the expected answer came regularly:

"Oh, rather better, thank you; but, Teddy-boy, do eat some of that candy out on the locker, for I *can't* look at it when I get up." Which Teddy very obligingly proceeded to do, until it was a wonder how he ever reached the shores of Ireland alive. But, strange to say, he seemed to thrive on this sort of treatment, and no one landed at Queenstown in better condition than lovely May evening than Master Teddy.

I have n't told you his full name, and as no one ever called him anything but Teddy, it does n't much matter. His father had died when his little son was a mere baby, leaving him to the care of the young mother. Teddy was very fond—and secretly very proud—of his pretty young mother, who was more of a chum than a strict guardian.

But after landing on Irish shores, when the traveling began, Teddy's troubles began too.

If they would only go to see some good, new, handsome buildings in the cities they come to, thought Teddy, or to some big factories where

they make things! But no sooner did they arrive at a decent sort of place, like Killarney for instance, where there was a chance for a small boy to enjoy himself, than it was: "Now, Teddy dear, we are going to see a wonderful old abbey."

"Abby — Abby who?" grumbled the boy. "I'd rather go with Dennis, the boatman. He says there's great fishing in that pool below the second lake."

But it was no use. "Abby" carried the day; and Teddy, with nose in air, sniffed contemptuously at Gothic windows and ivy-covered tower, until the others almost wished he had been left to Dennis and the fish.

It was the same all the way along, as they zigzagged up through Ireland, over into Scotland, and then down into England, dragging poor Teddy with them to abbeys, and cathedrals, and, worse than all, picture-galleries.

Here in London it had been harder than anywhere; and after two hours one morning in Westminster Abbey, and another at the Na-

tionally the 'Maze'—were not bad; but the British Museum — oh, my!"

"Is there anything over here that you really do want to see, Teddy?" said Mrs. Knight, hopelessly. (Mrs. Knight and her daughter Marian were the two ladies who were traveling with his mother.)

"Yes," answered Teddy, stoutly; "the King."

"What?" exclaimed Miss Marian. "Why, Teddy-boy, I thought you were fiercely republican. I thought you did n't like kings."

"Well," replied Teddy, "can't a fellow want to see an enemy once in a while? And they say he's a good sort, as kings go. Anyhow, I'd rather see him than anything else in this whole country. But, Miss Marian, what's his crown good for? You know they showed it to us in the Tower the other day. If he does n't keep it on all the time, I should think he'd want it at home to look at."

"Possibly they are afraid of burglars, Teddy," said the young woman, soberly.

But Teddy's special grievance that morning was that it was the famous fourth day of July. What a great day it was at home in America! And he was spending it in London!

In London of all places! The home of the red-coats, the British, the enemies of all Yankee school-boys, as his imagination extravagantly painted them! And of course there was no celebration of the "Glorious Fourth."

"No fire-crackers, no torpedoes, no fireworks, no cap-pistol, no nothing!" mourned Teddy, and he kicked the railing and sulked.

"Hail, Columbia, happy land!" sang a merry voice down below.

"Morning, Ada," called Teddy, as he thrust his head under the railing and looked down to where a pretty little girl stood on the front steps. "Where are you going?"

"With papa," said Ada, "to do some American sight-seeing, he says."

"Huh!" said Teddy, with scorn, "where'll you find it over here?"

"Oh, there's the Lincoln tower on the church where Dr. Newman Hall used to preach, and the Peabody buildings, and the grave of Captain John Smith; and we shall go into the abbey and see the bust of Longfellow; and — don't you want to come with us, Teddy?"

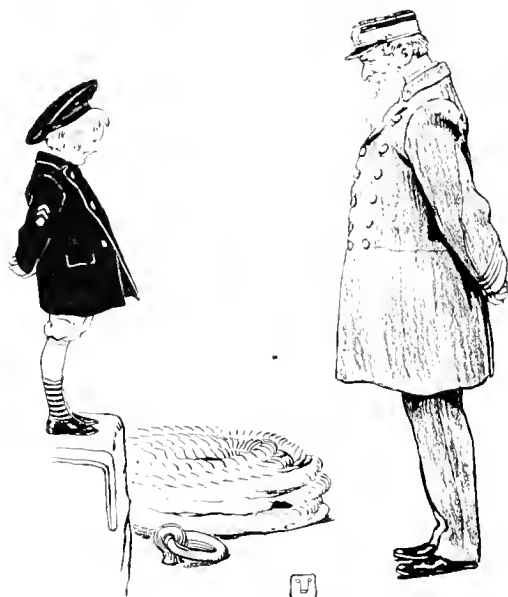

"HE MADE FRIENDS WITH THE CAPTAIN."

tional Gallery. Teddy had looked so pale and exhausted that his mother relented, and, with a sigh, concluded that his education must be continued along other lines.

"I don't mind the Tower," said poor Teddy; "and Kew Gardens and Hampton Court — spe-

"No, thank you!" said the boy, hastily drawing back at the word "abbey." "I'll have to stay at home and write to grandma. But, Ada, you don't know any place near here where a fellow could get some ice-cream, do you?"

"Not near by; only that shop away up on Oxford Street where we went once. You remember that, Teddy?"

"Guess I do!" was the reply. "No, I thank you; I don't care to spend a lot of sixpences that way again very soon."

A week before, when out on a sight-seeing trip, Ada and Teddy had discovered a small sign in a cake-shop window bearing the magic words, "Ice-cream," and had begged their mothers to take them in and give them a treat.

With much elation the children had each ordered an ice; but when the waitress put the toothsome dainty before them, Teddy looked at the quantity (about a large teaspoonful), and said: "Yes, that 's the kind I want; please bring me six of 'em."

She brought them, in six saucers, and then vanished to tell the tale to four other waitresses, who all hovered around the doorway to watch the small American boy who ordered ice-creams by the half-dozen.

That was the longest Fourth-of-July morning in all his life, but in slow fashion it did move along, and when the lunch hour came Teddy, although still depressed, was quite ready for it.

The house was in the highly respectable but rather dull neighborhood of Russell Square, and was a boarding-house much frequented by Americans. The two tables in the dining-room which Teddy entered were almost filled with his

own country-people. There was only one exception—a young Englishman named Lawson, who, it was said, had made the house his home before it had become so thoroughly American. With true British persistence, he refused to be crowded out by United States travelers. He was very quiet and gentlemanly even when the eagle screamed the loudest, and only occasionally entered a mild protest when comparisons



"TEDDY'S FACE BRIGHTENED AS HE REACHED HIS SEAT."

between things English and things American seemed to be going all one way.

Teddy's face brightened as he reached his seat, for just before his plate there waved a cluster of small American flags. There were at least a half-dozen of them, and over at the other side of the table in front of Ada were as many more, and the little girl's face smiled across at him as she leaned over to whisper:

"I bought them, Teddy; papa and I found them at a shop in the Burlington Arcade and brought them home. Are n't they lovely?"

Truly no great silken banner at the head of marching battalions had ever looked so beautiful to Teddy as did those modest little Stars and Stripes that homesick day. There was some-



"SO, A LITTLE LATER, THE TWO CHILDREN WERE BUSY FASTENING THEIR FLAGS ALL OVER THE BALCONY."

thing suspiciously like a lump in his throat, and the red, the white, and the blue seemed to be all running together into a blur before his eyes. He would have liked to stand up and salute them, and say as they did in school, "I pledge allegiance to my flag"; only, not being a "spread-eagle" boy, of course he did n't.

After lunch in the parlor, as the children gathered their flags together, a brilliant idea struck Teddy.

"Oh, Ada, let 's decorate our balcony with the flags."

"You don't suppose it would make Miss Murray and Mr. Lawson feel badly, do you?" said polite little Ada.

Mr. Lawson, standing near the children, overheard the last remark, and laughed as he said: "Not at all, Miss Ada. I quite admire your Stars and Stripes, and all they stand for; and Miss Murray, you know, is a Scotchwoman, so I am sure she could n't possibly object."

Miss Murray was the landlady, and a very pleasant one, too.

"And the neighbors?" said Ada, anxiously; "do you think they 'd mind — about the Fourth, I mean?"

"Indeed, no," replied the Englishman, soberly. "I really don't think there is any one about here who would mind it at all."

So, a little later, Miss Murray yielding a ready consent, the two children were busy fastening their flags all over the balcony. They really made a brave showing when finally adjusted, and Ada and Teddy went across the street to admire them.

"It 's fine!" said the boy; "and —"

Teddy never finished that sentence, for just then an officer on horseback came riding down the street and ordered a man with his cart of vegetables to move along. "The King and Queen are coming this way," he said.

"Hurrah!" cried Teddy; and across the street, up the steps, and out to the decorated balcony sped the children, calling to the others in the house as they ran. They had hardly time to reach this point of vantage before the mounted escort turned the corner.

"Oh, Teddy," cried Ada, "the flags! the flags! What will King Edward say when he sees them, for he certainly will remember that it 's the Fourth?"

"Too late!" said the boy, trembling with excitement, for at last he was to see the King.

Along came the escort, — "Red-coats — all of them," thought Teddy, — and then an open carriage, and in it their Majesties King Edward and Queen Alexandra.

Would the King see them? Would he see the flags? Yes, it was a quiet street, with not much to pique the curiosity of kings or anybody else. He looked up to the balcony, he smiled, he called the Queen's attention to the little patriots, and then he raised his hat and remained uncovered until the carriage was well past the house.

"Do you s'pose," gasped Teddy — "do you s'pose he remembered 't was the Fourth?"

"I should n't wonder at all, Teddy," said his mother, stooping over to hug her boy. "Anyhow, he saluted our own dear flag."

"Well, he 's a gentleman, all right, if he *is* a king," declared Teddy.

It had seemed to Teddy that up to this time the American people in the house with him had thought very little about its being their national holiday; but this incident seemed to rouse all the dormant patriotism in them, and at the dinner-table that evening the flags fluttered again, and many a knot of red, white, and blue ribbon was to be seen on the ladies' dresses and the coats of the men; and when Mr. Lawson came in with two tiny flags—the English and the American—crossed on the lapel of his coat, the enthusiasm was great.

The evening was spent by many of them in the parlor and the balcony leading from it, for the night was warm; and while one presided at the piano, the others sang all the patriotic songs

stood with Teddy out on the balcony, while they looked up at the starlit sky.

"Yes, but I—I wish I could have had my ice-cream."

"Bless the boy!" said Mr. Lawson, as he sat smoking his cigar near them. "He shall end the day to suit his little American heart if I can accomplish it"; and he started up, threw his cigar into the street, and disappeared into the house.

There followed a somewhat lengthy conversation over the telephone between this young man and the manager of a neighboring hotel, and then Mr. Lawson came back to the parlor and sought out Teddy's mother.

"Would you kindly lend me your son for a little while? I want to take him and Ada to the hotel to end the day with a truly American treat."

And so presently the two wondering and expectant children were on their way with the kind young Englishman; and when the hotel was reached and they entered the great dining-room, a serving-man led them to a table where, in a moment, they were each helped to a heaping plate of ice-cream and a bewildering assortment of fancy cakes.

I dare not tell you how much Teddy ate, but it was a right royal treat indeed that his kind friend provided; and it was a very

happy boy who sleepily murmured to his mother that evening as he went to bed:

"'T was 'most as good a day as at home, mama; and the ice-cream—was—'peachy'; —and— and— I've—seen—the—King!"



"THEY WERE EACH HELPED TO A HEAVING PLATE OF ICE-CREAM."

they could remember: "America," "The Star Spangled Banner," "Hail, Columbia," "Marching Through Georgia," and many others.

"If we only could have had a few fireworks, it would have been perfect," said Ada, as she



A FOURTH-OF-JULY MORNING IN THE DAISY-FIELD.

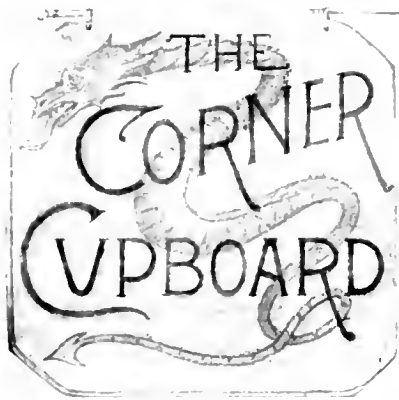

By MARGARET JOHNSON



THE sun had already been up for hours, and was busy setting fire to the windows in all the cottages looking seaward, touching up the tops of the waves with a most engaging glitter, turning brown sails to bronze and white to silver, and doing his best generally to present to the world a brilliant and satisfactory sample of a fine summer morning by the sea.

But this little ceremony of introducing a new day was not left entirely to the pleasure of the sun in Coquisett Harbor.

Boom! went the gun—like a big drum-major giving his orders—from the boat-house on Coquisett Island, where the governor's cottage stood. Brisk and blithe in the wake of the ponderous roar broke out the tripping notes of the reveille, and all the dancing yachts in the harbor answered, one after another, in a soft hurry of silvery bells chiming the hour in many different keys. Up went the flags with a rush, caught and challenged by a spanking breeze. "Eight bells, and *now* it is morning!" said the gun and the bugle and the bells and the flags to the laughing sun.

"Eight bells, and all 's well!" cried Kitty Magee, and she thrust a radiant face out of the seaward window of "The Corner Cupboard," to greet the day thus gallantly ushered in.

"I'm not so sure about that!" said a voice from behind the green curtain which divided the main apartment of the Cupboard from the store-room beyond. "Is it well to be exhausted with untimely toil when other people are just getting up? And to be famished for lunch when the rest of the world has n't had breakfast?"

"'T is the voice of the sluggard," declaimed

Kitty, still leaning out of the window; "I heard him complain—"

"No, you did n't!" Grace emerged from the dusky recesses in which she had been rummaging. "I'm not complaining. I'm only expounding my philosophy of life. But if you won't be edified, come in and get to work! True, the supply of paper-cutters is at present nearly, if not quite, equal to the demand: but who knows—"

"Don't be sarcastic, Gracie!" said Kitty, blithely, still intoxicated with the morning air. "I feel perfectly sure that we are going to begin to make our fortunes to-day! The summer boarder has arrived. I see him, her, it, here, there, and everywhere—"

"Except here," murmured Grace, glowering over the motto she was burning upon a rough shingle.

Kitty withdrew reluctantly from the window, and, sitting down at a little table, seized a paper-cutter and began to portray thereon the figure of a lobster with lavish energy and scarlet paint.

"If you like this paper-cutter *rezy* much, Gracie," she observed affectionately, "I'll give it to you at Christmas. Aunt Frieda says—my goodness gracious!"

A tremendous knock upon the frail front door caused the contents of the Cupboard to rattle alarmingly. Kitty's brush made an unexpected splash, which she promptly turned into a deformed lobster claw; but Grace did not lift her head.

"It 's Billy," she observed calmly. "By the time he has walked over from the hotel in the morning, he feels the need of a little active exercise. I'm glad you did n't go up the rain-pipe

and come down through the trap-door in the roof, Billy Reed!" she continued, opening the door.

"Morning, ladies," said Billy, entering cheerfully—a long youth in flannels, with sleepy blue eyes, and a fine coat of tan on his boyish features.

"How 's business?" he inquired, bowing to each of the girls with his hand on his heart.

"Hustling!" answered Kitty, with spirit.

"Twelve customers yesterday, while you were out sailing, you wretch! And they all bought fudge, and one of them a ten-cent stamp-box besides! Not a minute to lose—come, Billy, get to work."

"Work, quotha!" Billy cast an appealing glance at the rafters. "When I've been up since day-break bailing out the *Lily May*. What, in the name of common sense, do you want me to do now?"

"Redecorate the window, there 's a good boy," said Kitty, promptly. "Who knows what effect a new disposition of our treasures may have upon the S. B. (that 's short for summer boarder). There 's some of yesterday's fudge on the table behind you. I should have eaten it up myself, but Grace always will save it for you."

*"O to Grace how great a debtor
Daily I'm constrained to be!"*

said Billy, devoutly, choking himself with a huge mouthful of candy.

"Tell me what it is you want me to put in the window," he finished, when he could speak again, "and I 'll do it this instant minute."

The Cupboard stood on a corner, of course,—the corner of a lane and another lane. What else would you expect in Coquisett Harbor? It had been originally the quaint land home of an old sea-captain, one of those mysterious little structures which cling to the shore of the harbor like barnacles to a rock—gray, rough, weather-beaten, with a window looking seaward and another on the lane leading down to the ferry, a wide door, and a crazy step or two. The girls had found it the summer before, when they had spent a month at Coquisett with Aunt Frieda—Kitty's aunt, not Grace's, for the



"AUNT FRIEDA, ON A QUAIN OLD SETTEE, WAS USUALLY DEEP IN THE LATEST NOVEL."

"firm" were fellow-students at an art school in the city. They had dreamed of it all winter. They had made a delicious trip down in the spring, and hired it from a granddaughter of the original owner. They had coaxed Aunt Frieda to lend it the support of her dear, gray-haired, placid presence. They had fitted it up as a studio in June, arranging to board with Mrs. Denny, in her cozy old colonial house just across the way. There the two girls had met Billy Reed—also down at the shore thus early in order to make arrangements at the hotel for himself and his invalid mother, who

turned out to be an old school friend of Aunt Frieda's. While the girls were at work in the Corner Cupboard, Aunt Frieda, on a quaint old settee in Mrs. Denny's "best room," was usually deep in the latest novel.

Billy had promptly annexed himself to the Corner Cupboard in the capacity of guide, philosopher, and man-of-all-work. It was he who had put up the sign now swinging under the gable, a beautiful creation in burnt wood, with a realistic dragon curling his flaming tail about the modest letters. Let the unwary summer boarder first be lured by this work of art. A step would then bring into view the glories of the window; another, the open door; and, his foot once across the threshold, that boarder and his pocket-book were lost! Or, at least, thus Billy declared, in the fervor of youthful hope.

And who, indeed, could withstand the esthetic charms of the Cupboard? A great fish-net was draped over the green curtain, entangling various incongruous works of art in its homely folds. The windows were hung with yellow cheese-cloth, the seats beneath piled with cushions, cotton-covered, bran-stuffed. The rough beams of the ceiling were adorned with Japanese lanterns and giddy nothings made of tissue-paper; and the tables, and the cunning shelves upon the walls, and the stairs which led to the tiny loft were crowded with wares — knickknacks of birch-bark, shell, and burnt wood, views of Coquisett lighthouse and other scenes of local interest, reproduced on every available object from a needle-book to a pair of bellows; and scattered here and there among all the fantastic medley, Grace's clever sketches in water-color and pen-and-ink.

"Put a pewter porringer and a candlestick in the window, Billy," directed Kitty, briskly. "Now, which do you like best, those spoons of Grace's or my lobster paper-cutters?"

"I would n't take either of 'em for a gift," said Billy, candidly. "I hate to discourage you; and, of course, my taste and the taste of the summer boarder —"

"That will do," said Kitty, severely. "Your tastes appear to be equally benighted. I grieve to say. But would n't you think —" she appealed to him with sudden pathos — "that, just for the sake of the moral principle, Coquisetters

would patronize such an enterprise as this? Two really deserving girls, winning their way to fame and fortune, and trying to provide for next winter's study out of this summer's Cupboard,— would n't you think they would simply rush to support us?"

"Don't they?" said Billy, struggling with a fish-net which threatened to entangle him "for good" in the window.

"Don't they!" echoed Kitty, tragically. "Do they! The only one that rushes is Mrs. O'Halley. She comes three times a week, and turns over everything in the studio, and never buys a thing! And look at the attractions we offer! Tea — *good* tea, solid silver strainer and Aunt Frieda's grandmother's cups. And then there 's prime fudge — pure maple, real cream, and nuts from the home farm — all for the absurdly small sum of a quarter for the full of a clam-shell, with the date in gilt letters thrown in, free of charge! And our goods — paper-cutters that *cut*, picture-frames that stand alone; and still they don't buy!"

"Why," inquired Billy, cautiously, "if I may ask,— why, then, do you continue to produce these works of art?"

"Force of habit," said Grace, grimly. "It 's like strong drink — now that we've begun, we can't stop. We shall go on painting all summer, and then organize in the fall the 'S. P. P. P.' — Society for Providing the Poor with Paper-cutters and Picture-frames. Does anybody want anything from the Dismal Swamp? I 'm going in for some more shingles to make cheerful mottos on."

"It 's a little discouraging," Kitty dropped her voice as her partner disappeared behind the curtain. "The summer 's going so fast! It 's for Grace I mind, you know. I 'm a little no-account thing, so far as art is concerned, and I don't really have to do it; but Grace does, and she 's a genius — she would n't be a Belknap if she were n't. The Belknaps have always had everything but money.— birth, breeding, talent, — ask Aunt Frieda. If somebody would only recognize Grace, and give her a start! When she is sarcastic like that, it 's because she is hurt inside. She counted a good deal on this summer, I know; and I can't bear to see the weeks go by and have her disappointed."

"I see," said Billy, soberly. "I'd buy the truck — treasures, I mean — myself, much as I should hate to have 'em lying around, only —"

"Mercy on us!" cried Kitty. "*You!* I should as soon think of finding a customer in one of Captain Ephraim's lobster-pots! Hush! — Did you find the shingles, dear? They 're in the — Billy Reed, what are you doing over there?"

"Coming right back," said Billy, hastily. "I just wanted to sample the — the paper-cutters."

"And the fudge," added Kitty, reproachfully.

*"O Billy, in our hours of ease
Alert to torment and to tease,
When work and worry wring the brow,
O what a broken Reed art thou!"*

I made that up for you last night."

"Hear mine!" cried Grace, interrupting the victim's applause.

*"O Billy, in our hours of work
A most unmitigated shirk,
Let fudge appear — O my, O me! —
Your industry would shame the Bee!"*

"Much obliged, I 'm sure," said Billy, suavely. "I could keep it up like that all day, you know :

*"O Kitty, in the summer-time
Bedecked with freckles all sublime,
How will they look — just tell me that —
When seen beneath your winter hat?"*

*"O Gracie, when the shopper shops,
As sweet as maple lollipops,
When custom fails and boarders sniff
You'd freeze the very syrup stiff!"*

"O Kitty,—

Say, girls! hold on — wait! I've got it!"

Billy leaped from the window-sill in a spasm of sudden inspiration.

"Got what?" cried Kitty. "Not the S. B.!"

"No, no! the idea! The S. S.—secret of success!" Billy's sleepy eyes twinkled with unwonted energy. "How do they do these things in the great 'metropolus'? 'Sdeath! are we too proud to advertise? Something unique and fresh in the way of posters is the very thing

the Cupboard needs to make it go: something to catch the public eye.— to fix the wandering fancy of the S. B. And here 's all this poetic faculty going to waste among us! Great Scott! why did n't I think of it before! You girls can do it just as easy; like this, you know — ahem!

*"Old Mother Hubbard
She went to the Cupboard
To get a small gift for herself.
When she got there
The Cupboard was bare —
Coquisett had cleared every shelf!"*

"Bravo!" cried the girls, applauding wildly.

"Or this," said Billy, with modest elation.

"Help me out, Gracie, if I get stuck.

*"How dear to this heart are the scenes of the
seaside,
When fond recollection presents them to
view!"—"*

*"How gaily I wandered the sunny shore BE'-
side."*

struck in Grace,—

"Regardless of sunburn, or sand in my shoe!"

*The pier and the plank and the little steam-ferry
I've run for so often, and always in vain;
The succulent clam and the wild huckleberry,
And e'en the rude Cupboard that stood in
the lane:*

*The quaint little Cupboard, the trim Corner
Cupboard,
The moss-covered Cupboard that stood in the
lane!"*

They finished all together in a jubilant chorus. Grace's eyes were intent. "I believe we could!" she said. "They would attract attention, anyway; and I could illustrate them. And if they were really clever —" Her voice trailed off into silence. Her look became fixed.

"Genius burns!" whispered Kitty, ecstasically. "And when Grace once gets started — I knew fortune was on its way to us to-day. Billy, I take it all back —

*"When toil and trouble wring the brow,
An angel of a Billy thou!"*

The posters appeared the next morning, one in the Cupboard window, two or three among the goods, and others at Merritt's Drug-store and Noble's Emporium, both much frequented by idle Coquissetters. Some were graceful, some were funny, some contained "local hits" in rhyme, and all were decorated with Grace's clever and amusing sketches.

The results were immediately manifest. Twice as many people as usual visited the Cup-

board to spare. "We have n't made our fortunes yet, young man!"

"No, but we're on the highroad!" cried Kitty. "If only the prince would appear now, we should have nothing left to wish for."

"The prince?" said Billy.

"Grace's prince. My lady yearns for patronage on a grand scale, instead of being content to store up the humble penny, like me. I can hardly trust her to wait on the casual customer



"'MUCH OBIGED, 'M SURE," SAID THE... "WOULD REEF IT LIKE DOST... 'NOW?"

board during the day; and on the next day and the next these came again, and brought others to laugh over the clever posters, of which Grace's busy fingers had made a fresh supply.

"Gracious!" cried Billy, joyously, making his usual entrance "from the flies" one day, just after the tea-drinkers had dispersed. "What a crowd! I guess I'd better lay in a paper-cutter or so before they're all sold out, had n't I?"

"Help yourself," said Grace, grimly. "Plenty

now, she is so high and mighty since Fortune smiled a wee smile on us."

"If you two are going to stay over there and gossip," said Grace from the opposite window-seat, "you'd better give me a signal if you see the casual customer approaching."

"We will," said Kitty. "One if by land, and two if by sea. Oh, don't you wish it *would* be by sea! Grace's prince ought to come that way, of course. How full the harbor is to-night! There's the governor's yacht, the *Dris*,

She came in yesterday, you know, while you were away."

"By the powers, so she did!" Billy almost fell out of the window in a sudden fury of excited interest.

"He comes to his cottage on the island almost every summer," explained Kitty, with the importance of superior knowledge. "And he's a very nice man, they say, the governor is. Captain Denny's seen him."

"You don't say so!" Billy was curiously quiet again, and his blue eyes looked sleepier than ever. "How would his Excellency do for Grace's prince?" he suggested lazily.

"Very well, I should think," laughed Kitty. "But don't put any more such notions into her head, I beg of you! Ahem! Grace—customer!"

"Wait on him yourself—you can't trust me!" returned that haughty damsel, continuing to recline on her bran-pillows; and she refused to do any more business that night.

But her faithful mentors were not to be disheartened in the work of reformation, and her disdain of lowly custom was properly rebuked in a new poster shortly after tacked upon the Cupboard wall:

*"True virtue oft in humblest guise is found:
Behind the penny works the dollar round;
And she who cares for the trivial stranger cares
May ennobled a governor unawares!"*

"Good-by, Kit—Grace stopped to look in at the studio door. . . . day a week or two later.

"Good-by," said Kitty. "Take care of Aunt Frieda!"

She watched the two as they went down the lane, bound on a shopping trip to the city, and



"SHE BROUGHT OUT GRACE'S SKETCHES, ONE BY ONE; AND THE GRAY GENTLEMAN PRAISED THEM."

then came back to her busy afternoon. For an hour or so customers were plenty. Then there was a pause.

"I shall have to drink my tea alone, I guess," Kitty murmured as the afternoon waned. But this she was not destined to do; for, just as the table was ready, a broad shadow fell across it, and the portly figure and beaming smile of Mrs. O'Halley followed the shadow.

"O my soul!" moaned Kitty to herself. "She'll stay forever! I wish—" But here her native hospitality got the better of her impatience, and it was a demure and charming

Kitty who accompanied the lady in her enthusiastic tour of the Cupboard, and explained, one after another, the treasures which she had fully explained twenty times before.

Then it was tea for Mrs. O'Halley, and again it was a smiling though exhausted Kitty who presided over the kettle; but she did wish that some one else would appear to divert the good lady's flattering attentions, and was glad when an elderly gentleman with a keen, kind face came in, on his way to the ferry, for a cup of tea and some fudge. He listened amiably while Mrs. O'Halley poured forth over the fragrant cups her admiration for the young artists and their work, and, when she had finished, asked if he might see some of the pretty things so highly spoken of.

"The poster in the window," he observed, "is a very clever piece of work. It shows quite unusual talent, I should say."

Kitty glowed. Here was recognition, indeed, of the true sort! "That is n't at all Miss Belknap's best work," she cried loyally. "May I show you something else?"

She brought out Grace's sketches, one by one; and the Gray Gentleman (she called him that because his hair and clothes were grizzled to nearly the same shade) praised them with a discrimination that made her blush for joy.

"The young lady ought certainly to have the best advantages," he said, buying the prettiest one on the spot. "And these knickknacks—? The ladies at my house are getting up some sort of function, I believe; and I am sure they would like some of these for favors. I'll just take a few as samples, if you please."

Kitty thought at first, in amused dismay, that he meant to take the whole stock. But after buying enough copies of Coquisett Light to illuminate Darkest Africa, he desisted, saying that he would send the ladies to select for themselves.

"You have posters inside as well as out," he observed, strolling about the studio, while Kitty tied up his bundle.

"*True virtue —*"

"Oh, *that!*" Kitty turned hastily, laughing and blushing. "That was n't meant — Billy

must have put it up again. It was just for fun, and I took it down right away!"

"Oh, Billy put it up again, did he?" said the Gray Gentleman, continuing to regard the placard with grave interest.

"*True virtue oft in humblest guise is found;
Behind —*"

A faint noise sounded overhead. Kitty looked up, startled, to see the form of Billy appear cautiously at the head of the stairs, whence he beckoned wildly for a moment, with frantic though noiseless signals of distress, and then vanished without a sound.

"*Behind the penny lurks the dollar round;
And she —*"

Again Billy appeared, hovering over the balusters like a demented ghost. Again he signaled with distracted gestures, pointing first to the placard and then to the Gray Gentleman.

"*And she who for the trivial stranger cares
May —*"

Billy dropped silently upon the step, rocking to and fro in an ecstasy of anguish and despair. Kitty turned white. She gasped with fearful premonition.

"*May entertain a governor unawares!*"

With the last words the awful truth broke upon her. Her poster was a boomerang — her warning had recoiled with fatal aim upon herself! The Gray Gentleman *must* be the governor himself!

Expecting nothing less than instant annihilation, she stood awaiting her doom for one eternal moment, her breath gone, her tongue cleaving to the roof of her mouth. Then a placid voice broke the silence.

"Very good!" it said. "I trust you manage to live up to that very worthy sentiment!" And when Kitty lifted her eyes from that abyss of fear and self-abasement, the Gray Gentleman was smiling!

What happened next still more clearly re-

membered. It was said afterward that the visitor reported himself as having been delightfully entertained by one of the prettiest and most modest little girls he had ever met. But Kitty knew nothing about that. He went at last, leaving word that he would send for his purchases later; and Mrs. O'Halley went — when she got ready; and Grace and Aunt Frieda came home just in time to find Kitty collapsing on the window-seat, while Billy dashed headlong down the stairs, to the imminent danger of the diminished stock.

"Was it — the *governor*?" gasped Kitty, gazing wild-eyed.

"It was — it was the governor!" replied Billy, with sepulchral emphasis.

Grace and Aunt Frieda collapsed in their turn at these fateful words. But something made Kitty start to her feet with a sudden exclamation.

"William Reed!" she said solemnly. "Look at me! You — I do believe you knew it all the time!"

William Reed's face wore the blush of conscious guilt. "I cannot tell a —" he began.

"You sent him!" cried Kitty, with rising excitement. "How could you! How did he know? *Tell* us, Billy!"

"Well, you see," said Billy, modestly — "ahem! — the Gray Gentleman 's a very nice man, Kitty, the governor is! And he happens — just happens, you know — to be my uncle!"

"Billy Reed! You fraud! What do you mean? How could you! Why did n't you tell us before?"

Billy ducked beneath the fire of questions and reproaches.

"Don't!" he begged. "Don't kill me! I'll explain, truly, if you'll only listen! I thought you might think I was stuck up or something, don't you see, — the fellows have guyed me so; and then I did n't know how it would work — uncle might be too busy, or not interested. So I made the mater promise not to tell till I was ready —"

"That poster!" breathed Kitty, with a fire

of vengeance in her eye that made Billy double up with unholy glee.

"Richness!" he cried. "Well, luckily enough, uncle remembered Aunt Frieda and the Belknaps; and when I told him what I wanted him to do, he caught on like a duck, joke and all. Throw up your hats, girls! the Cupboard 's made; for if he once takes an interest in a thing, it 's bound to go. And he adores pluck, and is great on art; and if Gracie has really got the right stuff in her, he 'll give her, somehow, the start she wants."

"Just a *little* start!" cried Grace. "I can do all the rest myself!" She turned abruptly to the window, the Cupboard being too small to hold so great a joy. Boom! went the boat-house gun across the water, followed faithfully by the bugle and the bells and the flags. And, thus warned that setting time was come, the obedient sun dropped softly out of a great surge of splendid color in the cloud-filled west, and left a trail of glory across the rippling harbor and the rosy sails. Speechless, Grace stood and gazed. Who knows what visions appeared to her girlish eyes in that glory — of rapturous work and study, of New York and Paris, of ambitions realized and dreams fulfilled!

"Look at her!" whispered Kitty, her own eyes dewy with sympathetic joy and tenderness. "She 's in the seventh heaven at the very thought! Billy — angel — I forgive you! How can we ever thank you?"

"Not me!" laughed Billy, red through all his tan. "Uncle 's the angel, and it 's he — him — it — you ought to thank! Hold on — what 's that about old Timotheus?" He clutched his forehead wildly, and, after an interval of frenzied thought, burst forth, to a round of applause which made the joyous Cupboard ring again, in a final paroxysm of poetic utterance:

*"O not for me the winner's prize —
Let uncle keep the cup :
I drew a governor from the skies,
He raised a mortal up !"*

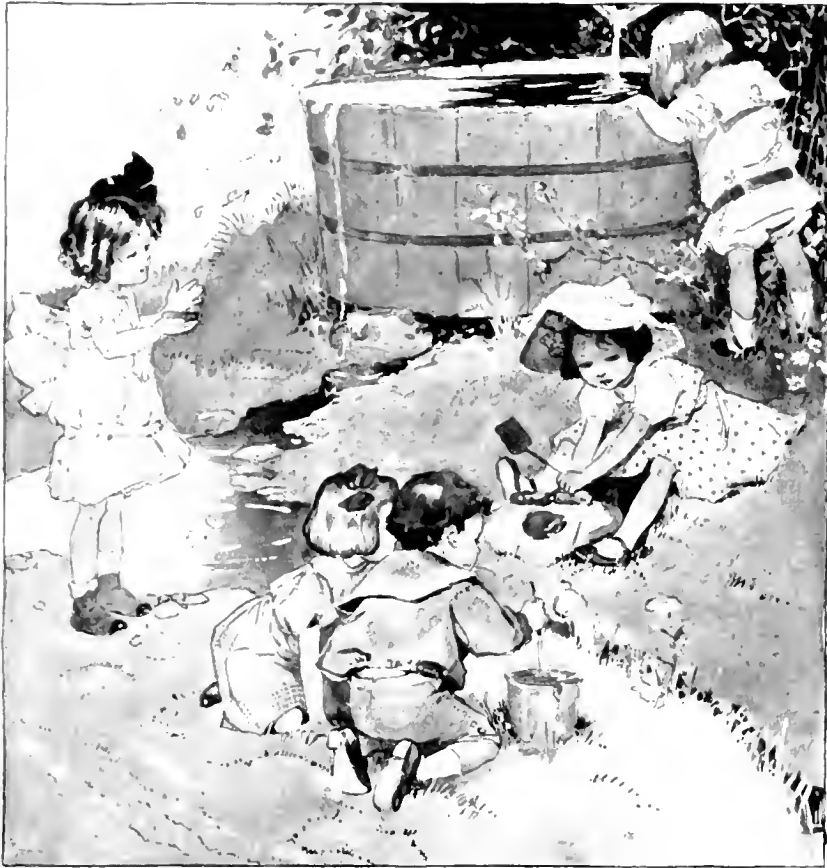

MUD-PIES.

THE Grown-Ups are the queerest folks; they never seem to know
That mud-pies always have to be made just exactly so.
You have to have a nice back yard, a sunny, pleasant day,
And then you ask some boys and girls to come around and play.

You mix some mud up in a pail, and stir it with a stick;
It must n't be a bit too thin,— and not a bit too thick.
And then you make it into pies, and pat 'em with your hand,
And bake 'em on a nice flat board, and my! but they are grand!

Carolyn Wells.

QUEEN ZINI OF IX.

Copyright, 1905, by L. FRANK BAUM.

BY L. FRANK BAUM,

Author of "The Wizard of Oz."

CHAPTER XVII.

THE DESCENT OF THE ROLY-ROGUES.

KING BUD and Princess Fluff were leading very happy and peaceful lives in their beautiful palace. All wars and dangers seemed at an end, and there was nothing to disturb their content.

All the gold that was needed the royal purse-bearer was able to supply from his overflowing purse. The gigantic General Tollydob became famous throughout the world, and no nation dared attack the army of Noland. The talking dog of old Tallydab made every one wonder, and people came many miles to see Ruffles and hear him speak. It was said that all this good fortune had been brought to Noland by the pretty Princess Fluff, who was a favorite of the fairies; and the people loved her on this account as well as for her bright and sunny disposition.

King Bud caused his subjects some little anxiety, to be sure; for they never could tell what he was liable to do next, except that he was sure to do something unexpected. But much is forgiven a king; and if Bud made some pompous old nobleman stand on his head, to amuse a mob of people, he would give him a good dinner afterward and fill his purse with gold to make up for the indignity. Fluff often reproved her brother for such pranks, but Bud's soul was flooded with mischief, and it was hard for him to resist letting a little of the surplus escape now and then.

After all, the people were fairly content and prosperous, and no one was at all prepared for the disasters soon to overtake them.

One day, while King Bud was playing at ball with some of his courtiers on a field outside the city gates, the first warning of trouble reached him. Bud had batted a ball high into the air, and while looking upward for it to descend he

saw another ball bound from the plain at the top of the North Mountains, fly into the air, and then sink gradually toward him. As it approached, it grew bigger and bigger, until it assumed mammoth proportions; and then, while the courtiers screamed in terror, the great ball struck the field near them, bounced high into the air, and came down directly upon the sharp point of one of the palace towers, where it stuck fast with a yell that sounded almost human.

For some moments Bud and his companions were motionless through surprise and fear; then they rushed into the city and stood among the crowd of people which had congregated at the foot of the tower to stare at the big ball impaled upon its point. Once in a while, two arms, two short legs, and a head would dart out from the ball and wiggle frantically, and then the yell would be repeated and the head and limbs withdrawn swiftly into the ball.

It was all so curious that the people were justified in staring at it in amazement; for certainly no one had ever seen or heard of a Roly-Rogue before, or even known such a creature existed.

Finally, as no one else could reach the steeple-top, Aunt Rivette flew into the air and circled slowly around the ball. When next its head was thrust out, she called:

"Are you a mud-turtle or a man?"

"I'll show you which, if I get hold of you," answered the Roly-Rogue, fiercely.

"Where did you come from?" asked Aunt Rivette, taking care the wiggling arms did not grab her.

"That is none of your business," said the Roly-Rogue. "But I did n't intend to come, that you may depend upon."

"Are you hurt?" she inquired, seeing that the struggles of the creature made him spin around upon the steeple-point like a windmill.

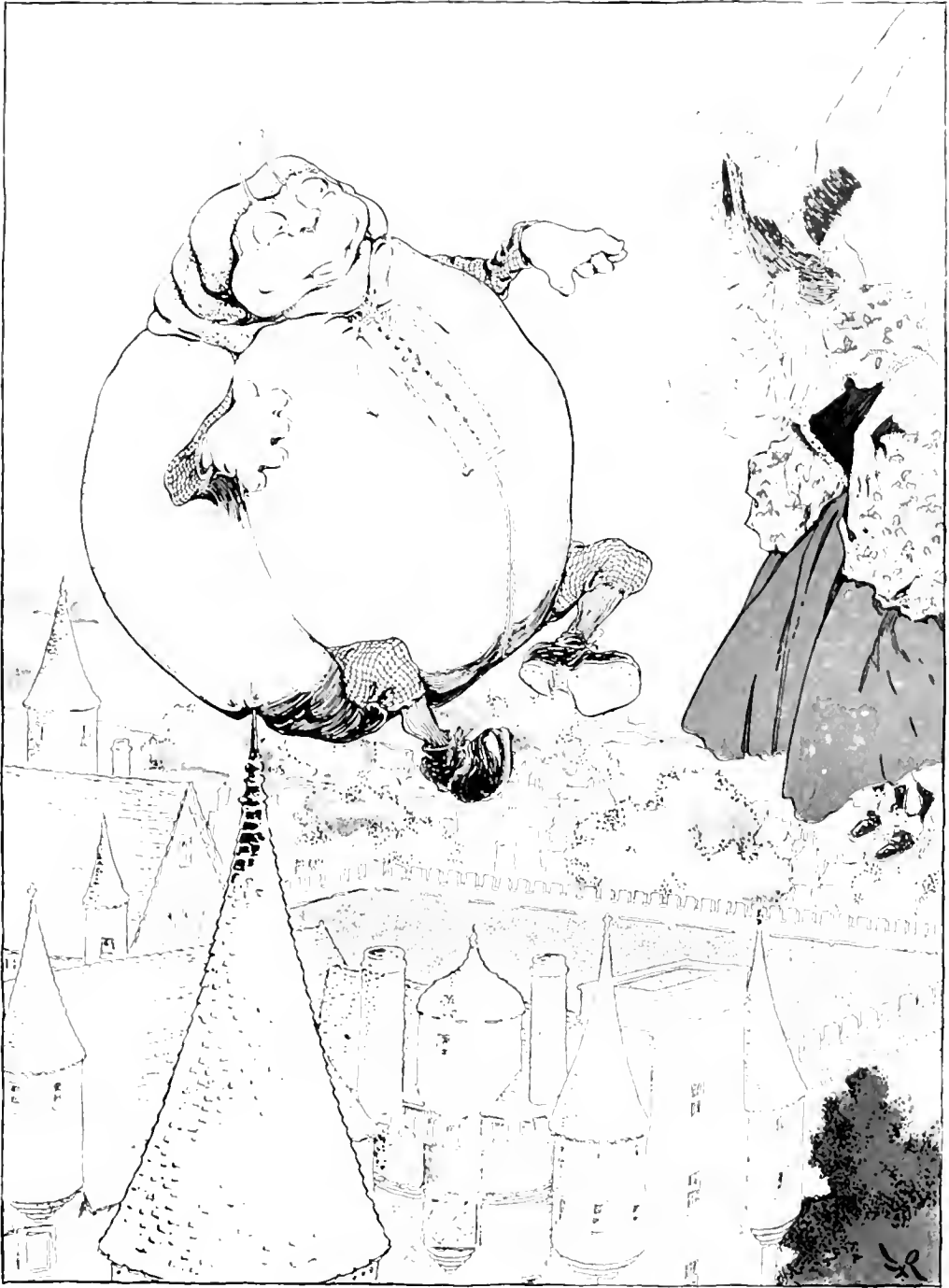

“WHERE DID YOU COME FROM?” ASKED AUNT RIVETTE.

"No, I'm not hurt at all," declared the Roly-Rogue; "but I'd like to know how I'm going to get down."

"What would you do if we helped you to get free?" asked Aunt Rivette.

"I'd fight every one of those idiots who are

"We might have him gilded," proposed the old woman, "and then he'd look better."

"I'll think it over," said the king, and he went away to finish his ball game.

The people talked and wondered about the queer creature on the steeple, but no one could say where it came from or what it was; they were naturally much puzzled.

The next day was bright with sunshine; so, early in the forenoon, Bud and Fluff had the royal cook fill their baskets with good things to eat, and set out to picnic on the bank of the river that separated Noland from the kingdom of IX. They rode ponies, to reach the river sooner than by walking; and their only companions were Tallydab, the lord high steward, and his talking dog, Ruffles.

It was after this picnic party had passed over the mountain, and were securely hidden from any one in the city of Nole, that the ruler of the Roly-Rogues and his thousands of followers hurled themselves down from their land above the clouds and began bounding toward the plain below.

The people first heard a roar that sounded like distant thunder; and when they looked toward the North Mountains they saw the air black with tiny bouncing balls that seemed to drop from the drifting clouds which always had obscured the highest peak.

But, although appearing small when first seen, these balls grew rapidly larger as they came nearer; and then, with sharp reports like pistol-shots, they began dropping upon the plain by dozens and hundreds and then thousands.



"THE GREAT BALLS SEEMED TO DROP FROM THE DRIFTING CLOUDS."

laughing at me down there!" said the creature, its eyes flashing wickedly.

"Then you'd best stay where you are," returned old Rivette, who flew back to earth again to tell Bud what the Roly-Rogue had said.

"I believe that is the best place for him," said Bud; "so we'll let him stay where he is. He's not very ornamental, I must say, but he's very safe up there on top of the steeple."

As soon as they touched the ground they bounded upward again, like rubber balls the children throw upon the floor; but each bound was less violent than the one preceding it, until finally within the streets of the city and upon all the fields surrounding it lay the thousands of Roly-Rogues that had fallen from the mountain-peak.

At first they lay still, as if stunned by their swift journey and collision with the hard earth; but after a few seconds they recovered, thrust out their heads and limbs, and scrambled upon their flat feet.

Then the savage Roly-Rogues uttered hoarse shouts of joy, for they were safely arrived at the city they had seen from afar, and the audacious adventure was a success.

CHAPTER XVIII.

THE CONQUEST OF NOLAND.

It would be impossible to describe the amazement of the people of Nole when the Roly-Rogues came upon them.

Not only was the descent wholly unexpected, but the appearance of the invaders was queer enough to strike terror to the stoutest heart.

Their round bodies were supported by short, strong legs having broad, flattened feet to keep them steady. Their arms were short, and the fingers of their hands, while not long, were very powerful.

But the heads were the most startling portions of these strange creatures. They were flat and thick on the top, with leathery rolls around their necks; so that, when the head was drawn in, its upper part rounded out the surface of the ball. In this peculiar head the Roly-Rogue had two big eyes as shiny as porcelain, a small stubby nose, and a huge mouth. Their strange leather-like clothing fitted their bodies closely and was of different colors—green, yellow, red, and brown.

Taken altogether, the Roly-Rogues were not

pretty to look at; and although their big eyes gave them a startled or astonished expression, nothing seemed ever to startle or astonish them in the least.

When they arrived in the valley of Nole, after their wonderful journey down the mountains, they scrambled to their feet, extended their long arms with the thorns clasped tight in their talon-like fingers, and rushed in a furious crowd and with loud cries upon the terror-stricken people.

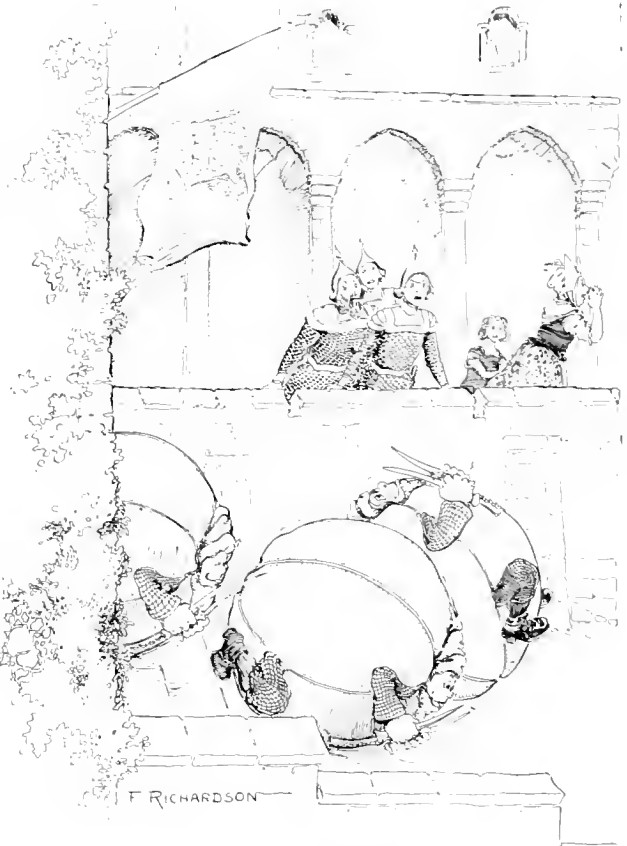

"AS FOR THE WOMEN AND CHILDREN,

The soldiers of Tollydob's brave army had not even time to seize their weapons; for such a foe, coming upon them through the air, had never been dreamed of.

And the men of Nole, who might have resisted the enemy, were too much frightened to do more than tremble violently and gasp with open mouths. As for the women and children, they fled screaming into the houses and bolted

or locked the doors, which was doubtless the wisest thing they could have done.

General Tollydob was asleep when the calamity of this invasion occurred; but hearing the shouts, he ran out of his mansion and met several of the Roly-Rogues face to face. Without hesitation the brave general rushed upon them; but two of the creatures promptly rolled themselves against him from opposite directions, so that the ten-toot giant was crushed between

the general started to run away. But other foes rolled after him, knocked him down, and stuck their thorns into him until he yelled for mercy and promised to become their slave.

Tullydub, the chief counselor, watched all this from his window, and it frightened him so greatly that he crawled under his bed and hid, hoping the creatures would not find him. But their big round eyes were sharp at discovering things; so the Roly-Rogues had not been in Tullydub's room two minutes before he was dragged from beneath his bed, and prodded with thorns until he promised obedience to the conquerors.

The lord high purse-bearer, at the first alarm, dug a hole in the garden of the royal palace and buried his purse so no one could find it but himself. But he might have saved himself this trouble, for the Roly-Rogues knew nothing of money or its uses, being accustomed to seizing whatever they desired without a thought of rendering payment for it.

Having buried his purse, old Tillydub gave himself up to the invaders as their prisoner; and this saved him the indignity of being conquered.

The lord high executioner may really be credited with making the only serious fight of the day; for when the Roly-Rogues came upon him, Tellydeb seized his ax, and, before the enemy could come near, he reached out his long arm and cleverly sliced the heads off several of their round bodies.

The others paused for a moment, being unused to such warfare and not understanding how an arm could reach so far.

But, seeing their heads were in danger, about a hundred of the creatures formed themselves into balls and rolled upon the executioner in a straight line, hoping to crush him.

They could not see what happened after they began to roll, their heads being withdrawn; but Tellydeb watched them speed toward him,



THEY FLED SCREAMING INTO THE HOUSES."

them until there was not a particle of breath left in his body. No sooner did these release him than two other Roly-Rogues rolled toward him; but Tollydob was not to be caught twice, so he gave a mighty jump and jumped right over their heads, with the result that the balls crashed against each other.

This made the two Roly-Rogues so angry that they began to fight each other savagely, and



"OTHER FOES ROLLED AFTER HIM AND KNOCKED HIM DOWN."

and, stepping aside, he aimed a strong blow with his ax at the body of the first Roly-Rogue that passed him. Instead of cutting the rubber-like body, the ax bounced back and flew from Tellydeb's hand into the air, falling farther away than the long arm of the executioner could reach. Therefore he was left helpless, and was wise enough to surrender without further resistance.

Finding no one else to resist them, the Roly-Rogues contented themselves with bounding against the terrorized people, great and humble alike, and knocking them over, laughing boisterously at the figures sprawling in the mud of the streets.

And then they would prick the bodies of the men with their sharp thorns, making them spring to their feet again with shrieks of fear, only to be bowled over again the next minute.

But the monsters soon grew weary of this amusement, for they were anxious to explore the city they had so successfully invaded. They flocked into the palace and public buildings, and gazed eagerly at the many beautiful and, to them, novel things that were found. The mirrors delighted them, and they fought one another for the privilege of standing before the glasses to admire the reflection of their horrid bodies.

They could not sit in the chairs, for their round bodies would not fit them; neither could the Roly-Rogues understand the use of beds. For when they rested or slept the creatures merely withdrew their limbs and heads, rolled over upon their backs, and slept soundly — no matter where they might be.

The shops were all entered and robbed of their wares, the Roly-Rogues wantonly destroying

all that they could not use. They were like ostriches in eating anything that looked attractive to them; one of the monsters swallowed several pretty glass beads, and some of the more inquisitive of them invaded the grocery-shops and satisfied their curiosity by tasting of nearly everything in sight. It was funny to see their wry faces when they sampled the salt and the vinegar.

Presently the entire city was under the dominion of the Roly-Rogues, who forced the unhappy people to wait upon them and amuse them; and if any hesitated to obey their commands, the monsters would bump against them, pull their hair, and make them suffer most miserably.

Aunt Rivette was in her room at the top of the palace when the Roly-Rogues invaded the city of Nole. At first she was as much frightened as the others; but she soon remembered she could escape the creatures by flying; so she quietly watched them from the windows. By and by, as they explored the palace, they came to Aunt Rivette's room and broke in the door; but the old woman calmly stepped out of her window upon a little iron balcony, spread her great wings, and flew away before the Roly-Rogues could catch her.

Then she soared calmly through the air, and having remembered that Bud and Fluff had gone

to the river on a picnic, she flew swiftly in that direction and before long came to where the children and old Tallydab were eating their luncheon, while the dog Ruffles, who was in good spirits, sang a comic song to amuse them.

They were much surprised to see Aunt Rivette flying toward them; but when she alighted and told Bud that his kingdom had been conquered by the Roly-Rogues and all his people enslaved, the little party was so astonished that they stared at one another in speechless amazement.

"Oh, Bud, what shall we do?" finally asked Fluff, in distress.

"Don't know," said Bud, struggling to swallow a large piece of sandwich that in his excitement had stuck fast in his throat.

"One thing is certain," remarked Aunt Ri-



"STEPPING ASIDE, TALLYDAB AIMED A STRONG BLOW WITH HIS AX AT THE BODY OF THE FIRST ROLY-ROGUE."

vette, helping herself to a slice of cake, "our happy lives are now ruined forever. We should be foolish to remain here; and the sooner we escape to some other country where the Roly-Rogues cannot find us, the safer we shall be."

"But why run away?" asked Bud. "Can't something else be done? Here, Tallydab, you're one of my counselors. What do you say about this affair?"

Now the lord high steward was a deliberate old fellow, and before he replied he dusted the crumbs from his lap, filled and lighted his long pipe, and smoked several whiffs in a thoughtful manner.

"It strikes me," said he at last, "that by means of the Princess Fluff's magic cloak we can either destroy or scatter these rascally invaders and restore the kingdom to peace and prosperity."

"Sure enough!" replied Bud. "Why did n't we think of that before?"

"You will have to make the wish, Bud," said Fluff, "for all the rest of us have wished, and you have not made yours yet."

"All right," answered the king. "If I must, I must. But I'm sorry I have to do it now, for I was saving my wish for something else."

"But where 's the cloak?" asked the dog, rudely breaking into the conversation. "You can't wish without the cloak."

"The cloak is locked up in a drawer in my room at the palace," said Fluff.

"And our enemies have possession of the palace," continued Tallydab, gloomily. "Was there ever such ill luck!"

"Never mind," said Aunt Rivette, "I'll fly back and get it—that is, if the Roly-Rogues have n't already broken open the drawer and discovered the cloak."

"Please go at once, then!" exclaimed Fluff. "Here is the key," and she unfastened it from the chain at her neck and handed it to her aunt. "But be careful, whatever you do, that those horrible creatures do not catch you."

"I'm not afraid," said Aunt Rivette, confidently. And taking the key, the old lady at once flew away in the direction of the city of Nole, promising to return very soon.

(To be continued)



"'BUT WHERE 'S THE CLOAK?' ASKED THE DOG."



THE SWALLOWS' REVENGE.

BY MARGARET WATSON.

WE are all very fond of the swallows. They go darting about so quickly, and make such a pretty little twittering, and never do any harm, only good, because they eat up the flies which nobody wants.

We used to wish and wish that a pair would build a nest in our porch, over the front door, as they did in the porch of Mrs. Nutt's cottage.

We wished and wished—and then one spring morning, when we came in from our walk with Miss Wilson, our governess, Nancy said: "I do believe the swallows are going to build in the porch at last. There 's a bit of mud stuck on the wall."

"Oh, where?" we all cried.

"Just there, up under the roof," said Nancy, pointing to it.

Then we all saw it. Just a few little dabs of mud sticking on the wall.

"Do you think the swallows did that?" I asked doubtfully.

And then, while we watched, a swallow came darting in over our heads and put another little dab of mud on the wall.

"There!" cried Nancy. "What do you say to that?"

So we sat and watched the swallows—all but Molly. First one and then the other came flying in and clung to the wall with its claws and wings, while it plastered a bit of mud on the nest.

We spent most of our spare time at that

window for the next day or two. It was so jolly to see the nest growing into shape.

The birds twittered over it, and talked to each other about it.

At last it was all plastered up, except the hole at which the birds were to go in and out, and they twittered round it, and flew up and down, as though they were looking to see if there was anything else they could do.

But they could n't see anything, so they darted away to catch a few flies for themselves, and rest a little on the telegraph wires.

In the morning the nest looked all right; but at noon, when we looked at it, there was a straw sticking out!

"What 's that for?" said I. "I did n't know swallows lined their nests with straw."

"They don't," said Nancy, looking serious.

"You don't think—" cried Dora, breathlessly.

"I do, though," said Nancy.

"Why, what do you mean, Nancy?" asked Miss Wilson.

"Sparrows build nests with straw."

"Oh!" cried Molly. "Would a sparrow steal a swallow's nest?"

"They do, sometimes," answered Nancy.

"What can we do?" said Dora.

"Could n't we wait, and frighten the sparrows away?" I suggested.

"No use," said Nancy. "That would be impossible, for we can't stay here all day."

"If you would n't mind lifting me up, Miss Wilson, I'd take that straw out, anyhow," I said.

So Miss Wilson lifted me up, and I pulled the straw out, and a feather came with it.

But we all felt anxious. Sparrows are not easily discouraged.

We hurried down to the dining-room window as soon as we could; Miss Wilson actually said we might do our practising in the evening. She was really interested in the stolen nest herself.

So we watched, and very soon a saucy little cock sparrow came, carrying a feather in his mouth, and popped into the nest, and bustled round and round in it, and then came out; and then the hen sparrow came, looking very slim and smooth, and she had a long straw, and dragged it after her into the nest, and twisted it round and round till she got it all in.

But just then the swallows came back.

They flew to their nest with a rush, twittering in a very anxious kind of way; and the hen sparrow put her head out of the hole and ruffled up all her feathers, and the cock ruffled up his feathers and flew at them, pecking right and left. The poor swallows beat about with their wings, and gave little harsh cries, and swept about the porch; but the sparrows had the nest, and their beaks were much stronger and harder than the swallows'.

"I'll turn that provoking hen sparrow out, anyway," said Dora.

So she carried a chair into the porch, and climbed upon it, and then the sparrow flew out; and, as soon as she took the chair away, one of the swallows flew in and turned round and round in it, flinging out the feathers and straw, and twittered away as happily as possible.

We were all so pleased.

But next morning, when we came down to breakfast, we found the sparrows had the nest again. So it seemed useless to do anything more.

When we came in, before dinner, we saw the swallows hovering about, and heard them talking to each other. So we settled down to watch.

We saw that the cock sparrow was inside the nest, making out to be very busy arranging it,

and the hen bird kept bringing him straws and feathers; but both the swallows came up with bits of mud in their beaks.

Suddenly they darted into the porch, and each put a dab of mud on the mouth of the nest.

The sparrow looked out and pecked at them, but he did n't try to come out; and the hen sparrow went inside, too.

Then one swallow flew away, while the other waited, hovering round the nest; and presently the first one flew back with some mud, and swooped in and put it on the nest. Then he waited there while the other went away for mud and stuck it on, too.

"Whatever are they doing?" I said.

"I can't think," answered Nancy. "It's very funny!"

They kept on, and by dinner-time the hole was much smaller.

"They're going to wall those sparrows in!" cried Dora, with a sudden startling inspiration.

"I believe they are!" exclaimed Nancy.

So we called father and mother and Miss Wilson to see, and they said they had never seen anything like it. It was quite evident that that was what the swallows meant, but the sparrows had n't begun to suspect them yet.

We asked Miss Wilson and mother if we might have a half-holiday to watch them. Miss Wilson was half inclined to say, "No," though it was clear she wanted to watch, too,—perhaps that was why,—but father and mother both said it was such a wonderful thing that it would be a pity not to see it.

So we had the whole afternoon, after we had had our dinner, and that did n't take us long.

They kept right on, one watching and the other going for mud; and at last the sparrows began to see that there was something wrong.

The cock put his head out and would have come out altogether, but the swallow clung to the edge of the nest and beat him back with his wings. After this they tried to get out once or twice, but I think they were thoroughly frightened, for they did n't seem to try very hard.

By four o'clock the thing was done. The sparrows were quite walled up in the swallows' nest, and not the tiniest hole was left; and the

swallows sat on the fence and twittered contentedly to each other.

"Well," said Nancy, "I never could have believed that birds could take a deliberate revenge like that."

"It serves the sparrows right," I said. "The little thieves!"

"But what will they do now? Will they leave them to starve to death?" asked Molly.

"They won't care," said Dora. "But it does seem rather hard."

"I think they're very cruel little birds," said Miss Wilson. "They're sitting on the fence and rejoicing in their work."

"Well, it was provoking to have those robber sparrows take their house, just as they'd built it so beautifully," said Nancy; "but it seems rather dreadful to starve them to death for it."

"They deserve to be thoroughly well frightened, anyhow," said I. "We might leave them in till father comes home, and let him see it, and then let them out."

"Yes. That would give them a lesson, I should think," said Nancy.

When father came home he was very tired, so we thought he had better have tea before we talked to him about the birds.

After tea we begged him to come out on the porch and see the nest.

He said it was wonderful.

"Don't you think we ought to let them out?" asked Dora. "It's a dreadful death to starve."

"How long has it been finished?" asked father.

"Oh, about two hours," answered Nancy.

"Then I think you need n't fear starvation for those sparrows—they must have died long ago. The nest is so well sealed up they could not get any air to breathe."

"Oh, father! do you think so?" cried Molly, and she began to cry.

"Well, we'll see," said father, and he made a hole in the nest with his knife, and put his hand in and took out first one sparrow, and then the other; but they were both quite dead.

Molly cried more than ever.

"Don't cry, child," said father. "They must have died in a few minutes—and it was their own fault. They had no business there."

"I suppose the swallows will come back and have their nest now," I said.

But they never did. The nest stayed there empty all the summer.

I wonder if it was haunted.

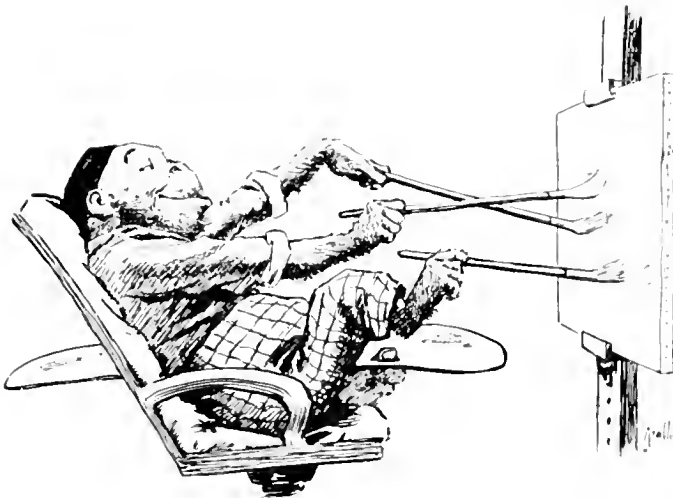

"TALK ABOUT YOUR AMBIDEXTROUS CHAPS—JUST WATCH ME!"

PINKEY PERKINS: JUST A BOY.

BY CAPTAIN HAROLD HAMMOND, U. S. A.

VI. HOW PINKEY CELEBRATED THE GLORIOUS FOURTH.

WHEN the glamour of the first few days of vacation had worn off, Pinkey Perkins was seized with a commendable desire to earn money. Fourth of July was coming, and Pinkey's ideas as to what would be an appropriate sum to expend in celebrating the day differed materially from those he could reasonably expect his father to entertain. Besides, he felt that it would be a very creditable move to branch out and earn something for himself, to have a source of income entirely independent of his parents' generosity.

About this time the boy who had been employed by Mrs. Betts in the Post Office Book Store moved away from town, and Pinkey at once applied for and secured the position thus left vacant. He was to receive the princely sum of sixty cents a week, which amount would provide him with sufficient fire-crackers, torpedoes, pin-wheels, and Roman candles properly to celebrate the Fourth, and leave a fair-sized surplus for other things.

Pinkey's principal duties were to sweep out the store in the morning and to deliver to the business houses on and near the public square the daily papers, which arrived on the noon train from the big city, two hundred miles away.

In his new situation, Pinkey felt a pardonable importance. It delighted him to note that his daily visit was always an event of moment to those who waited for the latest news from the outside world. It is true that the town of Enterprise could boast of two home papers, but they were weeklies and contained little news from beyond the county limits.

Bunny Morris, Pinkey's closest chum, envied Pinkey his position, which, aside from being a financial boon, brought him constantly before the public. As a consequence, Bunny, too, was seized with the money-making fever, and

at once set about seeking a "situation," as he was wont to term it. He went from place to place, without any decided opinions as to the special character of the service he would perform, or as to what the weekly wage should be. His one aim was to get the situation; what he could earn would be just that much clear gain.

After many fruitless and widely varied endeavors to obtain employment, Bunny finally was successful in securing the position of telegraph messenger at the railroad station, where all telegrams were received. For each message delivered beyond the public square he was to receive ten cents; all others he must deliver free. The situation was not a very paying one, but it carried with it certain privileges which meant more than the salary. It entitled him to admission behind the gate in the railroad office, forbidden ground heretofore untrodden by juvenile feet.

With the keenest delight did Bunny love to impress the importance of his position on the crowd of idle boys always about the station, by announcing with a very lordly air that he "must go in and get to work." In reality, there was not a thing for him to do, but he knew with what burning envy his auditors watched him as he passed through the wooden gate which bore the forbidding "NO ADMITTANCE" sign, on behind the counter, and, if he chose, clear into that holy of holies — the ticket-office. The best that his jealous companions could do was to go around to the other side of the station and look through the window at him.

Pinkey and Bunny had made their plans for a great celebration of the Fourth, and, for once in their lives, they were going to have enough material. Before they obtained employment their outlook had not been very rosy, and the fund which they had together accumulated since vacation began, to be expended in fire-crackers,

torpedoes, pin-wheels, and Roman candles, was still far below their desires.

But the financial outlook was now no longer serious, and they were assured of all that they had dreamed of in the line of pyrotechnics, with plenty of funds remaining to meet any and every other possible desire.

Enterprise had decided to observe the Fourth in grand style. According to the posters, there were to be a balloon ascension and parachute



IN THE PANTRY.

jump, a barbecue, two bands to furnish the music, and a wonderful display of fireworks at night. What more delightful prospects could any one desire than the pleasures offered by such a combination?

The post-office would be closed on the Fourth, and Pinkey would be free all day. But about two weeks before the Fourth, when several bill-posters arrived in town and spread broadcast over barns, fences, shops, and empty buildings the colored bills announcing that, in addition to the advertised celebration, there would be a circus in town on that day, Pinkey and Bunny were in a perfect whirlwind of excitement, and

wondered how in the world they were going to manage to see everything.

Now it happened that at that time the important office of the city marshal of Enterprise was held by one Jeremiah Satrap Singles, a very self-respecting person, and a passed master in the duties of constable.

And among the laws which "Old Tin Star," as the boys called him, specially liked to enforce was the usual ordinance that can be found on the records of any small town, prohibiting loafing about the railroad station, or "depot," as it is invariably called, or riding on the cars and engines.

Since Bunny had attained his position at the telegraph office, he and Pinkey had succeeded in making friends with the engineers to such an extent that they enjoyed the privilege of riding about the yards while switching was in progress, and frequently they rode all the way to the coal-mine, whither the engine went almost daily to get the output of the day before for shipment. Enterprise being the terminus of the branch line from the big city, the train that arrived in the evening remained overnight and departed again the next morning.

Notwithstanding the fear of the town marshal, the boys continued their riding; for Bunny felt that, employed as he was in the railroad office, he should not be molested. In fact, he felt a sort of partnership in the entire railroad system now, and secretly wondered how the company had ever prospered without his services. Pinkey, of course, was entitled to anything that Bunny enjoyed.

For a few days before the Fourth, however, Pinkey did not go to the depot. His fondness for that locality had become known to his parents, and he was at once ordered to stay away; and Pinkey feared that something might happen to interfere with the plans he and Bunny had made to go down early to see the circus-train arrive on the morning of the great day.

Fourth of July dawned bright and clear, to the booming of cannon fire-crackers and other ear-splitting noises invented to show patriotism.

True to their prearranged plan, Pinkey and Bunny met at Pinkey's house at a strangely early hour for them. Knowing that they would not get breakfast for several hours, they repaired

to the pantry and regaled themselves with the remains of an especially delicious custard-pie.

Even as it was, they were none too early; for, while still several blocks from the station, they heard a warning whistle at the crossing a mile from town, and at once broke into a run, arriving tired and panting, but on time to the dot, just as the long train pulled up to the platform.

Pinkey was the first to find the elephant-car, and he availed himself of the right of discovery by ascending the ladder at the end of the car and dispensing to the eager crowd about him fragments of information gained by peeping through a convenient opening near the top. He reported that there were "three big elephants and a baby one and four camels" in the car.

Then came the unloading of the gilded chariots, animal-cages, band-wagons, and all the circus belongings, and the removal of the same to the show-grounds in a vacant lot near by.

The wildest sort of guesses were made as to the probable contents of this or that box-like cage, adorned on the outside with gaudy paintings of unknown animals, but which in reality was filled with ropes, canvas, and tent-pins.

When, at last, the tents had taken definite shape, and all the visible animals and the cages containing the others had been taken inside (away from the gaze of the multitude), Pinkey and Bunny reluctantly decided to allow the circus to shift for itself for a time and go home to breakfast.

Pinkey could hardly eat his breakfast, so desirous was he of acquainting his parents with the wonders he had seen. As soon as he had finished, he effected a prearranged meeting with Bunny, and together the busy pair at once returned to their neglected circus.

But there was little to be seen at the show-grounds at that hour, so the boys decided to vary the program by going over to the station and enjoying a ride on the engine and

going out to the coal-mine, provided the engine made its usual trip that morning.

Keeping a sharp lookout, lest Jeremiah be somewhere in sight, the boys climbed up on the engine and, as was their custom, wished Mr. Plumber, the engineer, universally known as "Dad," and his fireman, a very polite "Good morning," and then remained discreetly silent.

They had long since learned not to ask permission to ride,—as that courted a refusal,—but had found it much better just to clamber aboard, maintain a respectful silence, and, to the best of their ability, keep out of the way.

And never did they miss a chance to be of



"WHAT WERE YOU KIDS DOING ON THAT ENGINE A FEW MINUTES AGO?"

any slight assistance in the way of filling the water-jug for the fireman, or handing a wrench or piece of waste to the engineer when he was out on the ground, oiling up. They never felt secure, however, until the fireman told them to get up and sit on part of his cushion, where they would be well out of the way. This position they

knew to be permanent until it was time for the train to pull out. Thus seated, they would shrink themselves into as small a space as possible, and remain perfectly quiet and subdued, rarely speaking even to each other.

On the morning in question, after switching in the yard for a while, Pinkey and Bunny, from their perch on the fireman's bench, saw the brakeman give the familiar signal, in reply to which Dad reached up and gave the whistle-lever two short jerks, and they heard the "toot—toot" from the whistle above the cab.

The two boys nudged each other eloquently and moved a little closer to the window in the front end of the cab, for they knew they were bound for the coal-mine. Life for them contained no more blissful moments than these, when they were permitted to sit in the swaying cab and look out on the track ahead and watch the two lines of steel being apparently devoured by the monster beneath them.

When they returned from the mine, about an hour later, and the cars of coal were coupled to the waiting train, their morning's ride came to an end and the two boys dismounted from the engine, intending to return to the show-grounds and see how preparations for the morning parade were progressing.

As Pinkey's feet reached the ground and he turned to walk away from the engine, his heart seemed to leap into his throat. There, not thirty yards away, seated with some other men on a pile of railroad-ties in the shade of a wheat-elevator, was Jeremiah Satrap Singles, his badge of office shining forth as a formidable reminder of his authority.

"Gee, Bunny, there's Old Tin Star! D'you s'pose he saw us getting off the engine?" said Pinkey, fearing to look again in the direction of the pile of ties.

"Oh; cracky! I hope not, Pinkey," replied Bunny, much disturbed. "'F he did, it's all up with us, an' he'll fine us three dollars and costs, and lock us up, too, maybe."

"And we'd miss the p'rade and the circus and the fireworks, too, Bunny."

"What d'you s'pose we'd better do—run?"

"I dunno 's there's any good in runnin', 'cause if he wants us he'll get us 'fore long, anyway. There's only one way to find out if

he saw us, and that is to give him a chance to catch us. If he saw us runnin', he'd know in a minute we were runnin' from him."

"What you goin' to do, Pinkey,—go up an' tell him we wuz ridin'?"

"What d'you take me for, anyway? Course I'm not goin' to tell him. Just you stay here and I'll find out if he saw us or not."

Without explaining to Bunny what his plans were, Pinkey walked deliberately over to the group of which the marshal was the central figure, and going straight up to him, asked in polite and respectful tones: "Mr. Singles, could you please tell me what time it is?"

Mr. Singles did not reply for a minute, but fastened a severe gaze on Pinkey, much to the boy's inward discomfort. Then he slowly took his watch from his vest pocket, glanced down at it for an instant, and as he snapped the case shut again, said in a most foreboding tone: "It's just five minutes to ten. What were you kids doing on that engine a few minutes ago?"

That settled it. There was no hope for them now. For a moment Pinkey stood silent and thoughtful, then he managed to muster the one word: "Riding."

"Well, you boys have been doing too much riding around here, and as soon as I can swear out a warrant for you I'll have you up before the justice of the peace."

Pinkey did not know that had Jeremiah desired to arrest him and Bunny just then, he did not need a warrant. Nor did he appreciate that, just at that moment, the preparations for the circus parade were as interesting to the marshal as to any one else.

"I'm too busy now to attend to your case," continued the comfortable Singles; "but as soon as I go up-town I'll see to it."

All this might be in real earnest or it might be said just to scare them, but Pinkey was not for taking any chances. For the first time in his life he realized the grim majesty of the law in all its terror, and he decided that the greater distance that he and Bunny maintained between themselves and Mr. Singles, the better for them.

There was nothing to do but to beat a retreat and inform Bunny of the fix they were in.

After getting several blocks away from the

railroad yards, they stopped to discuss matters and to decide on their future movements.

"What are we ever goin' to do?" asked Bunny, solemnly. "I 'spose it 'll cost us five dollars apiece for fines if we get taken up."



"IN THE AFTERNOON THEY FINISHED THEIR DAYTIME FIREWORKS."

"We 're not goin' to get taken up," said Pinkey, resolutely. "We 're goin' to the country just as fast as we can get there. What 's the use of stayin' here, just *waitin'* to get arrested?"

"An' miss the p'rade, an' the b'loon ascension an' fireworks, an' everything," moaned Bunny.

"What fun is there stayin' around town when Old Tin Star is liable to light on you any minute and arrest you? No, siree; I 'm goin' to take *my* fireworks and skip just as quick as I know how."

To Pinkey and Bunny "the country" meant the farm about two miles south of town where one of Pinkey's uncles lived, and where, during the holidays and on Saturdays, the two boys were frequent and welcome guests.

Bunny was soon convinced of the soundness of Pinkey's arguments, and the pair at once began their preparations for departure.

Their store of supplies was secreted in the woodshed at Pinkey's home, and thither they went as soon as their decision was made. While Bunny was stowing the fireworks in an empty bag, Pinkey scribbled a note on a scrap of paper, and slipped around the house and pinned it to the side door. There was no one at home, and no one saw him leave his message.

The note was decidedly brief, but it carried sufficient information to serve its purpose. It read:

Gone to country. If Mr. Singles asks you where we are, tell him you don't know exactly. P. & B.

Then they set out, making a wide circuit of the town to avoid detection and possible questioning. When their way was clear to the southward, they gave the main road a wide berth, keeping to the open fields. They imagined that Mr. Singles would probably inquire for them of every person he met, so they

avoided the human race in general, trudging doggedly on, weighed down by the heavy load of ill luck that had blighted their hopes.

Presently the sound of music came faintly to their ears, and they knew that the parade was in progress, and a cold chill settled on their hearts as every step took them farther and farther away from all that was dear to them.

When they arrived at their destination, they found the place deserted, the whole family having gone to town for the celebration. But they

were safe from pursuit. Out in the woods pasture they went with their store of fireworks, and there, in the shade of the large oak-trees, with no audience save the astonished animals who from a safe distance observed the strange performance, Pinkey and Bunny observed the Nation's Birthday with all the juvenile rites the situation would permit.

In the afternoon they finished their daytime fireworks, and then they enjoyed themselves about the farm until evening should come and they could set off the half-dozen sky-rockets they had brought with them.

Pinkey's uncle came home early in the evening to attend to the stock; and when the boys explained to him the cause of their absence from town, they were disappointed that he did not appear concerned about their plight, or even surprised at finding them there.

When they had unburdened themselves, he told them they need not be alarmed any further; that Pinkey's father had learned from Mr. Singles the cause for the note on the door and their hurried departure, and had promised for them that they would ride no more on the engine. Mr. Singles had consented to let them off this time only on

that condition, and if they wished to return home with that understanding, they were at liberty to do so, and no harm would come to them.

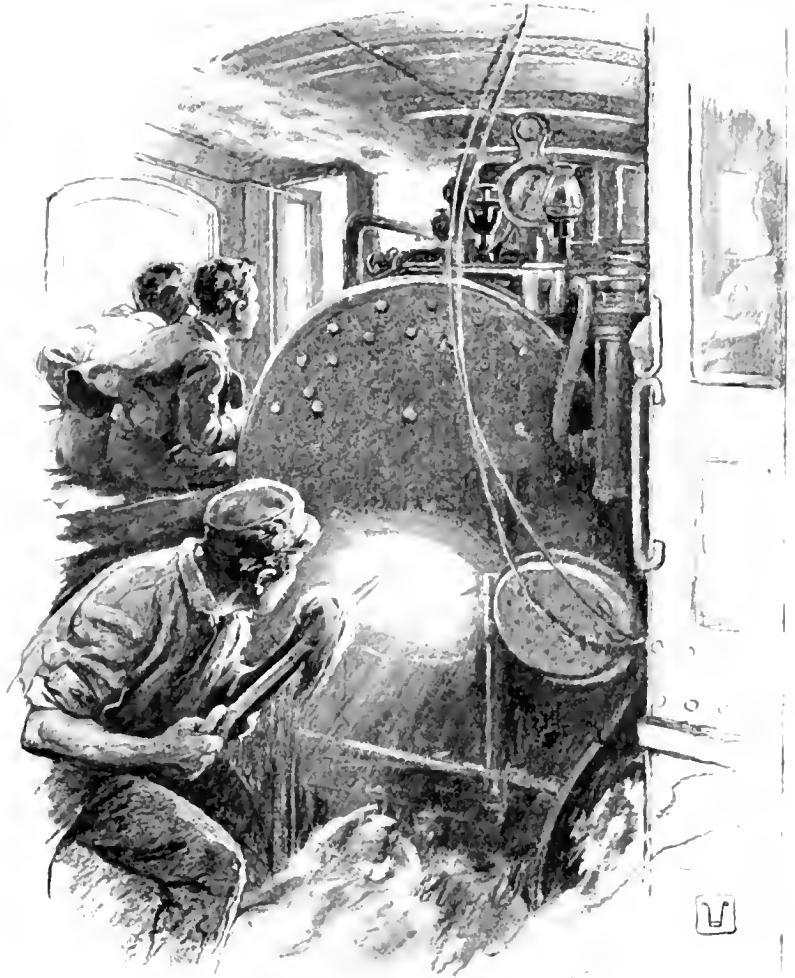

PINKEY AND BUNNY ON THE FIREMAN'S BENCH.

That night Pinkey and Bunny attended the circus, as they had planned in the beginning, and enjoyed it all the more, because on that occasion they felt as a rightful owner might who had recovered some lost, and valued treasure.

PHOTOGRAPHING A FLICKER FAMILY.

(With Pictures by Herman T. Bohlman.)

BY WILLIAM LOVELL FINLEY.



IF I were the owner of the Oregon firs about the reed-covered pond, I'd rather take a lease from the flickers than from any other bird family. They're not always a-moving south and leaving your trees without an occupant as soon as the first frost nips. When the thermometer drops low and the kinglets are twittering too softly to be heard more than a few yards away, "highhole" always sends a full share of bird cheer up and down the scattering woods. Nor is he half as particular as some of the bird residents. He takes the best of the few remaining stumps and seems satisfied. Once he pounded out a wooden home just below his last year's house. His wife did not like it very much, but they settled it in some way and reared a thriving family.

"Redhammer" of the West, like "yellowhammer," his Eastern cousin, is a rather odd mixture of woodpecker and robin. The *Picus* family in general takes its food from the bark of a tree, but redhammer often feeds on berries, grain, and earthworms. According to woodpecker taste, a bird should cling to the side of a tree, clutching two toes above and two below, with body propped by his tail; but highhole is independent and often sits on a limb as an ordinary percher. Nature has given the flicker a bill slightly curved, instead of straight and chisel-shaped. But why does this Westerner parade the woods in a jaunty suit lined with

red, while his Eastern cousin flaunts from tree to tree in a yellow-lined jacket?

Highhole is somewhat of a barbarian among the Romans about the pond. He knows nothing about, nor does he care for, the finer arts of architecture and music. A dark den suits him as well as a mansion. He has a voice like the "holler" of a lusty-lunged, whole-souled plow-boy. As he swings from stump to stump, his wings flash red like a beacon-light. He shouts, "Yar-up! Yar-up! Yar-up!" from the tree-top, or occasionally he breaks the woody silence with a prolonged, jovial "Ha! Ha! Ha! Ha! Ha! Ha! Ha!" Sometimes he sounds a softer chord in his nature. In the spring I have often seen him hitch slowly up the stump to his favorite trysting-place, where he calls, "Zwick-a! Zwick-a!" to his mate.

With a tinge of regret I've watched the clumps of fir thinned year after year. Highhole does not care a snap. He can bore a hole in a church steeple as easily as in a fir snag. The moral influence on his family is about the same in one place as the other. For two seasons I watched a red-shafted flicker rear his family in the tall steeple of a Presbyterian church in the heart of the city. Another flicker dug a home in one of the maples that border the walk about a large grammar-school. The poor hen



"IN THE HOLLOWED HEART OF A CERTAIN FIR LAY SEVEN GLOSSY EGGS."

was harassed half to death by attention from the boys, but she reared four lusty shouters.

I have known highhole for years. For two seasons we have photographed him and his family. He has punctured with doors and

windows every old stump about the pond. Every one of these old holes is dead to the deepest root, yet I generally find them throbbing at the heart more vitally than the greenest neighbor in the clump. Redhammer is not altogether idle during the months of rain and snow. When he does work, he goes like an automatic toy wound to the limit. As soon as the weather brightens into the first warm spring-like day, he and his wife have a wooden house well near its completion.



"WITH THE CAMERA READY TO SNAP, FIRMLY FASTENED TO A SMALL BOARD, WE CLIMBED THE TREE."

Few birds have larger families than the highhole. But were it not for the number of his family, how could he hold his own among so many enemies? His conspicuous size and color always make him a shining mark to the collector, for every village lad in the land has collected flicker's eggs. He is a fellow of expediency, however. If his home is robbed, his wife soon lays another set of eggs. It is on record that one pair, when tested by the removal of egg after egg, laid seventy-one eggs in seventy-three days.

In the hollowed heart of a certain fir, on a bed of fine wood bits, lay seven glossy eggs, inanimate, but full of promise. They all had the vital flesh-tinge of pink. Each imprisoned a precious spark of life, to be fanned by the magic brooding of the mother's breast.

Redhammer had grown quite trustful. We got a ladder twenty-five feet long, which reached

almost up to the nest. The eggs had been placed a foot and a half below the round entrance. On the opposite side from the entrance, and on a level with the eggs, we sawed out a back door, giving a good view of the living-room, and letting in a little sunlight. With the camera ready to snap, firmly fastened to a small board, we climbed the tree. Holding it out to a measured distance, we aimed it downward at the eggs. The first attempt came nearer landing camera and all in a heap in the shallow water of the pond, than getting a photograph of the eggs; but after several trials a good picture was taken.

Neither mother nor father flicker seemed exactly to understand our right of making free with their home. The former nervously returned to her nest each time we descended the tree. She climbed in the front door. It was easy enough to recognize her own eggs, but that new door was a puzzle. She had to slip out and examine it half a dozen times, return-



"THEY TRIED TO CLING TO OUR CLOTHING."

ing always by the round door above. This modernized dwelling made her a little uneasy, but she soon settled down, satisfied to brood



THE PARENT BIRD AT HIS
FRONT DOOR.

(Copyright, 1935, by H. T. Bohlman)

and watch her gossiping neighbors at the same time. After we fastened up the new entrance, flicker affairs went on as usual.

Some of our later visits were certainly a little tiresome for the brooding mother. A knock at the foot of the tree was generally followed by an impatient eye and a dangerous-looking long bill at the threshold, the greeting a busy housewife gives an intruding peddler.

With a bored look,

she flipped across the way and sat while the visitors nosed about and prowled in her house.

Those naked baby flickers were the ugliest little bird youngsters I ever saw.

In the heart of the fir the development was rapid. The thin, drawn lids of each callow prisoner cracked and revealed a pair of black eyes. Feathers sprouted and spread from the rolls of fatty tissue up and down their backs. Each bill pointed ever upward to the light. The instant the doorway darkened, each sprung open to its limit. The nestlings soon took to climbing the walls, not solely for amusement. The sharp ears of each youngster caught the scrape of the mother's claws the instant she clutched the bark of the tree, and this sound always precipitated a neck-stretching scramble toward the door. The young had little chance of exercis-

ing their wings; so the next time we climbed the tree with the camera, they were apparently full-grown, strong in climbing, but, to our advantage, weak in flying.

We are not likely to forget the day we climbed the stump to picture the young flickers. The full significance of the task had not struck us. Nor had the enjoyment of it dawned upon the fledglings. They were bashful at first, but after a little coaxing and fondling they were as tame as pet pussies. They

climbed out and crowded the stump-top, where they sat in the warm sunshine, stretching, fluffing, bowing, and preening.

They liked to cling to our clothing. A coat sleeve was easier climbing than a tree-trunk,



"ON GUARD."

and it was softer to penetrate with a peck. There was a streak of ambition in the soul of each flicker that would put most people to shame. They climbed continually, and always toward the top. Up our arms to our shoulders they would go, and then to our heads. Just at the instant one's mind and energy were directed toward balancing in the tree-top, he was sure to get a series of pecks in the cheek. One might endure the pecks of the sharp claws as they penetrated his clothing now and then, but he would be likely



"THEY CLIMBED OUT AND CROWDED THE STUMP-TOP."

to cringe under the sting of a sharp chisel-shaped drill boring with rapid blows into his arm.

I could n't see any use in the parents working themselves to death feeding such ravenous full-grown children. "They might as well 'hustle' a little for themselves," I said, as I climbed the stump next morning. We took all five of the fledglings to the ground. Wild strawberries they gulped down with a decided relish until we got tired and cut short the supply. We soon had a regular "yar-uping" concert. One young cock clutched the bark with his claws, his stiff-pointed tail feathers propping his body in the natural woodpecker position as he hitched nestward up the tree, followed by his mates.

Afterward, when I set all five on a near-by

aggravated patience of the bird photographer. "About face!" was executed with the same lack of discipline on the part of the feathered company. The captain stepped meekly around to the other side of the limb, and planted himself and camera in the rear.

During our early acquaintance the fledgling flickers savagely resisted our attempts to coax them out of their home. After a few hours in the warm sunshine, they fought every effort to put them back. They were no longer nestlings, for a bit of confidence had transformed them into full-fledged birds of the world.

The following day a casual observer might have noticed that the flicker population of the



"COMPANY, ATTENTION!" FRONT VIEW



REAR VIEW.

limb with the order, "Company, attention! Right dress!" they were the rawest and most unruly recruits I ever handled. If the upper guide did not keep moving, he received a gouge from his impatient neighbor below. This was sure either to set the whole squad in motion, or to start a family brawl, without regard to the

fir woods had increased. Here and there, one caught sight of a bird bearing the emblem of a black crescent hung about his neck. Juvenile "Yar-ups" echoed among the scattered trees and over the pond. Occasionally there were flashes of red as wings opened and closed and a bird swung through the air in wave-like flight.

HOW TO STUDY PICTURES.

BY CHARLES H. CAFFIN.

A series of articles for the older girls and boys who read "St. Nicholas."

NINTH PAPER.

COMPARING JOHN CONSTABLE (BORN 1776, DIED 1837) WITH JOSEPH MALLORD WILLIAM TURNER (BORN 1775, DIED 1851).

WHAT a contrast of serene simplicity and character of every tree and object in the familiar splendid audacity these pictures present! The scene. It was along the banks of this little river one, a loving record of something intimately familiar; the other, an amazing vision of the imagination. Turner's was painted in 1829—one of the finest works of this master, who is a solitary figure in landscape art, almost unapproached by others. Constable's picture appeared six years later—an excellent example of the painter who may be regarded as the father of modern landscape.

"The Valley Farm" itself is on the river Stour in the county of Sussex, England, near the mill at East Bergholt where Constable was born; for he, like Rembrandt, was a miller's son. It is a characteristic bit of English scenery, not grand or romantic; just a tiny bit of a little country, so home-like that those who love it, as Constable



"THE VALLEY FARM." BY CONSTABLE.

did, get to have a companionship with every detail, learning to know the line of its hills, the winding of its streams, and the position and

that he strayed in boyhood; whither, too, he came back, after he had been studying in London at the schools of the Royal Academy, and

copying the pictures in the galleries, especially those of Hobbema and Ruisdael. But he soon tired of looking at nature through the eyes of other men. "There is room enough," he wrote to a friend, "for a nature-painter. Painting is with me but another name for feeling; and I associate my careless boyhood with all that lies upon the banks of the Stour; those scenes made me a painter and I am thankful." This is the kind of spirit which, we have seen, inspired the Dutch landscape-painters of the seventeenth century; and, indeed their love of nature was reborn in Constable. For in the lapse of time

pictures—that the clouds might move and overhang the spot, that its atmosphere might penetrate every part of the scene, and that trees and water, and the very plants by the roadside, might move and have their being in it; and secondly, he put his own personal affection into his representation. Then, too, in the matter of color, which cannot be judged from the reproduction, he dared to paint nature green, as he saw it, and the skies blue, with the sunshine either yellow or glaring white.

It is, then, because of this closer faithfulness to the hues of nature, and to the effects of



"ULYSSES DERIDING POLYPHEMUS" BY TURNER.

their art had been forgotten; the Dutchmen themselves, like the painters of France and England, had forsaken the direct study of nature for an attempt to picture the grandeur of the classic landscape. Reynolds, who drew his inspiration from Italy, had set its stamp upon English portraiture; and Claude, the Italian-Frenchman, was the landscape-painter most admired.

Constable painted the scene as he saw it, but he was not satisfied with merely copying nature. It was to him so real a companion that, in the first place, he tried to make it live in his

movement, of atmosphere, and of light, and because he interpreted nature according to his own mood, that Constable is called the father of modern landscape. For these are the qualities that particularly occupied the artists of the nineteenth century.

On the threshold of this new movement stood Turner, alone among his fellow landscape-painters, the most imaginative of them all, who was less concerned with the truth of nature than with its splendors and magic. No one has equaled him in suggesting the mystery of

nature in its sublime forms. One turns to the "Ulysses Deriding Polyphemus," not to be drawn toward it and made to feel at home, as in the case of the Constable, but to be lifted up and filled with wonder at its strangeness and mysterious grandeur.

The incident depicted in it is from Homer's "Odyssey." The hero, Ulysses, in his voyage from Troy to his home in Ithaca, stopped at the isle of the Cyclops, and with his followers approached the cave of Polyphemus. The monster devoured six of the crew; but the hero plied him with wine brought from his vessel, and, while he slept, put out his single eye. The mariners then escaped to their ship, while Polyphemus, in his pain and rage, flung rocks in the direction of their voices. We see, his huge form writhing on the top of the cliff; the sailors scrambling up the masts to loosen the sails; the red oars flashing upon the water; a bevy of sea-nymphs around the prow drawing the ships to safety through the green water, the latter gilded with the reflections of the rising sun, that paints with gold and crimson the little clouds floating in the vaporous sky, wherein are rifts which reveal further depths of blue.

But really the incident was of very little account to Turner, except as it furnished him with a peg upon which to hang the splendors of his own imagination. Fourteen years earlier he had painted "Dido Building Carthage," which showed that Turner could compete with Claude, the landscape-artist then held in highest repute. But his mind was set upon further things; having proved that he could rival Claude, he would now be Turner—himself. At this time he paid the first of three visits to Italy, and the picture we are studying, painted after his return, reveals a heightened sense of color, and the magnificence of his imagination, probably, at his highest point.

The mystery of this picture, its spaces of light and darkness, that the eye explores but cannot fathom, we are conscious of at once. Moreover, if we think about it, we are sure that, if our eye could pierce the shadows and closely discern the formation of the rocks, definitely learn the structure of the ship and the appearance of its sailors, peer into the distance and discover exactly how each mass of cliff succeeds

another; if, in a word, our eye could grasp everything and convey the facts distinctly to our understanding, we should not enjoy the picture as we do. It is the sense of something hidden that is one of the sources of its enjoyment.

And then the strangeness of the picture—that arch of rock; the huge, roughly hewn figure of Polyphemus; a sky full of surprises to people who seldom see the daily pageantry of sunrise. But it is less in detail than in general character that the picture is strange. The artist has taken a theme of old times, when the world was young and things loomed very big to men's imagination. For to the ancients the world seemed huge and mysterious, and they peopled its unknown spaces with fanciful beings that were vague and large. In old Greece, as in the Norse mountains or the German forests, the old-time peoples imagined weird personages vast in size, only half formed in shape, whom they called either gods or giants; and it is the suggestion of this vastness, of the early beginning of things,—this great strangeness, in a word,—that helps to make Turner's picture so impressive. Turner's scene seems part of a vast new world; Constable's, a little spot that for ages the hand and heart of man have shaped.

Whether Turner felt toward nature the wonder which his pictures inspire in us, may be doubted. His life was a strange contradiction to the splendor and imagination of his work. Like many other great landscape-artists, he was city-bred. The son of a barber in London, he early showed a talent for drawing, and the father hung the child's productions on the wall of his shop and sold them to his customers. By degrees the boy obtained employment in coloring architectural designs, and at fourteen was entered as a pupil in the schools of the Royal Academy. The following year he exhibited his first picture. He worked with tireless energy, and during vacations went on walking tours, sketching continually and painting in water-colors; so that, by the time he was twenty-four and admitted as an associate to the Academy, he had exhibited pictures which ranged over twenty-six counties of England and Wales. During this early period his greatest success was made in water-colors, in which

he developed a remarkable skill. He would brook no rivalry. Girtin was at that time the most admired artist in water-colors; he set to work to surpass him. Having done so, he practically abandoned this work for oil-colors, and then threw down, as we have already noted, a gauntlet to the popular admiration for Claude.

Turner's rule of conduct, in fact, was "aut Cæsar aut nullus." Having established his supremacy over rivals, at least to his own satisfaction, he set himself to conquer a universe of his own. For a period of twelve years, beginning with the picture of Ulysses and ending with the one of a tug-boat towing to a wrecker's yard a ship of the line, "The Fighting Téméraire," and with "The Burial of Wilkie at Sea," he did his greatest work. For during this period his imagination was at its ripest and richest, displayed particularly in the majesty of moving depths of water, in skies of vast grandeur, and in the splendor of his color-schemes; moreover, the workmanship of his pictures was solid, and he still based his imagination on the facts of nature. But, as time went on, he studied nature less and less. He seems to have felt almost an intoxication of actual skill in using paint, until one may suspect that he thought more of the magic of his brush and paints than of the qualities of nature which he was supposed to be representing. So his later pictures were greatly inferior to his earlier work.

And during all these years his life as a man was morose and mean; his house in Queen Anne Street was dirty and neglected; and, finally, it was in a still more squalid haunt in a wretched part of London that he was found dead. When his will was opened, the curious contradiction that he was fond of hoarding money and yet refused to sell the majority of his pictures was explained. He had left his works to the National Gallery, and his money as a fund for the relief of poor artists. A strange mingling of greatness and sordidness, of boorish manners and kindly sympathy!

Constable, on the other hand, led a happy, simple life in the village of which he wrote, in one of his letters, published by his friend, the painter Leslie, "I love every stile and stump and lane." It was an out-of-door life, for he

Painted, as he expressed it, "under the sun"; observing the big clouds as they rolled inland from the North Sea, with their attendant effects of light and shadow. He became, in fact, the first of the modern school of open-air painting.

The Englishmen, however, of that date, paid Constable little honor. It is true he was made an associate of the Royal Academy in 1819, after which he moved from Suffolk and established himself in what was then the village of Hampstead on the northern outskirts of London: but it was not until he had been honored with a gold medal by the French that the Academy admitted him to full membership. Nor did this increase the public's appreciation; he died at Hampstead in very meager circumstances, but with the happy expectation that some day his pictures would be understood and valued. The expectation has been fully realized.

Such tardy reward has been the lot of many painters great enough to create something new. Turner would not have been so highly esteemed in his own generation but that Ruskin, the most admired writer upon art in his time, was his enthusiastic advocate, extolling him, indeed, with extravagant enthusiasm. Ruskin claimed for him every virtue of a painter; and the later discovery, that he was not so great as his advocate claimed, has somewhat obscured the greatness that was really his.

Moreover, the world has now become so persuaded of the beauty of the natural style of landscape-painting that it is distrustful of the imaginative. In its praise of Constable it rather pooh-poohs Turner.

This is a foolish and ignorant attitude of mind. The proper one for the genuine student is to recognize that in art, as in any other department of life, a man should be judged by what he himself is.

Now to a man who loves nature Constable must appeal; yet — it may be on a mountain, or in the presence of a sunset, or beside a little brook, anywhere, at any time — to the lover of nature may come a moment in which the details of the landscape are swept into forgetfulness, and all he is conscious of is a sense of his soul being strengthened, purified, exalted. It is so that Turner's best pictures may affect him.



THE GOOSE GIRL.

BY LUCY FITCH PERKINS.



Oh, I 'm a goose, and you 're a goose, and
we 're all geese together.
We wander over hill and dale, all in the
sweet June weather,
While wise folk stay indoors and pore

O'er dusty books for learning lore.
How glad I am—how glad you are—that
we 're birds of a feather:
That you 're a goose, and I 'm a goose,
and we 're all geese together!

HONEY-BEE.

BY LUCY FITCH PERKINS.



HONEY-BEE, honey-bee! Here is some money ;
Take it and bring us a pot of new honey!
Fly away! Fly, you buzzing old rover!
Gather us sweets from the blossoming clover!

"OUR FRIENDS THE TREES."

(Showing the branch, leaf, fruit, and general form of several of our common fruit and nut bearing trees. See page 862.)



WILD CHERRY.



QUINCE.



PEACH.



PLUM.



CHERRY.



APPLE.



CRAB-APPLE.



PEAR.

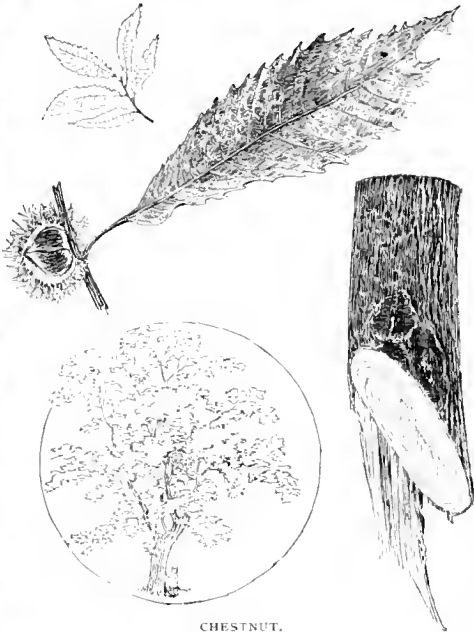
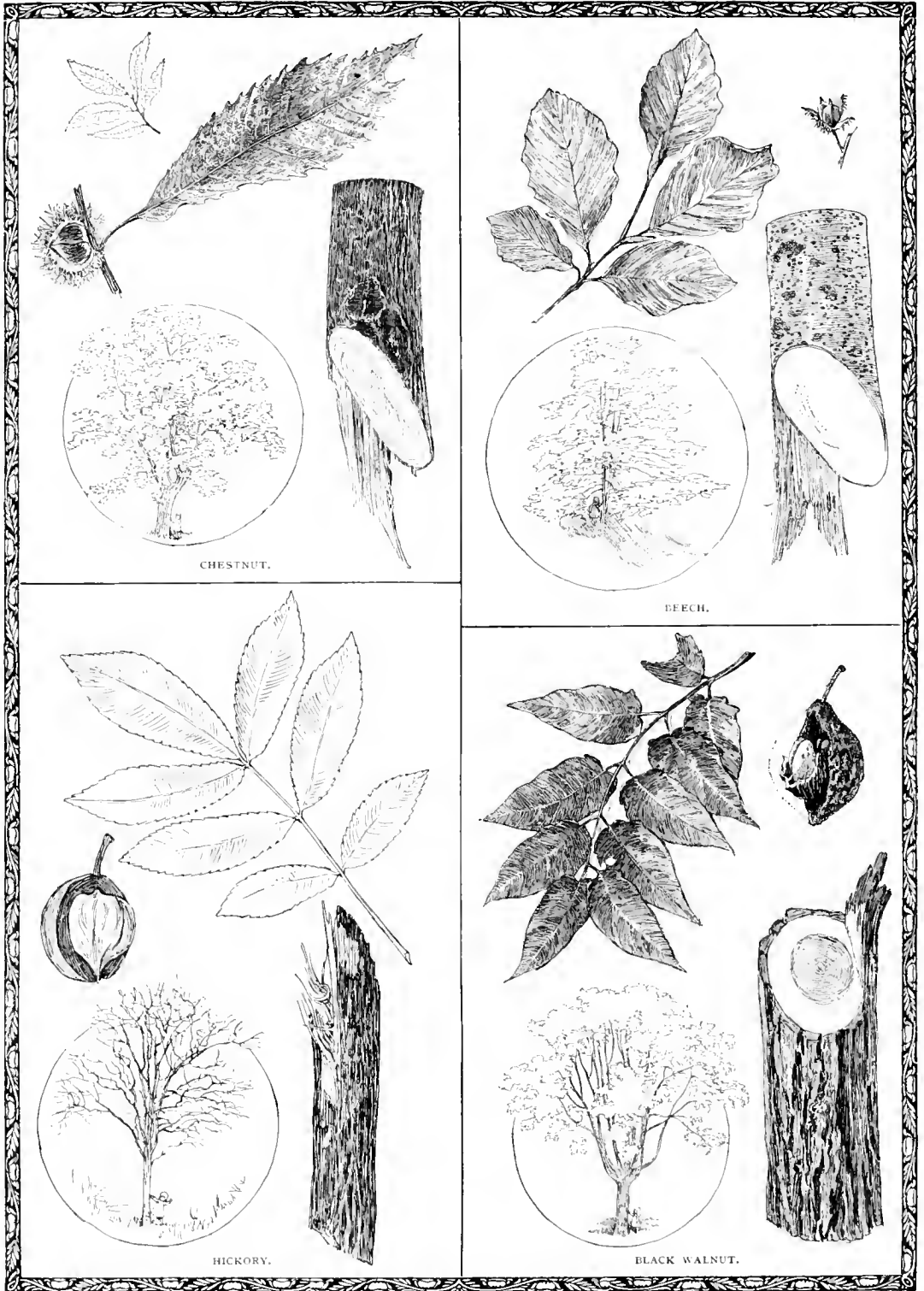

CHESTNUT.

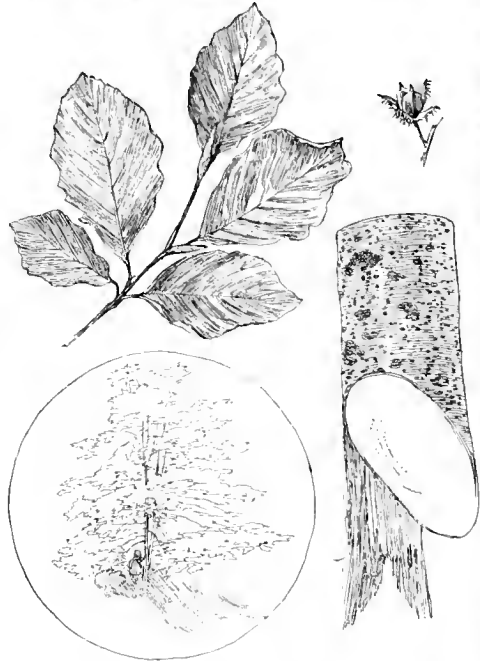

BEECH.

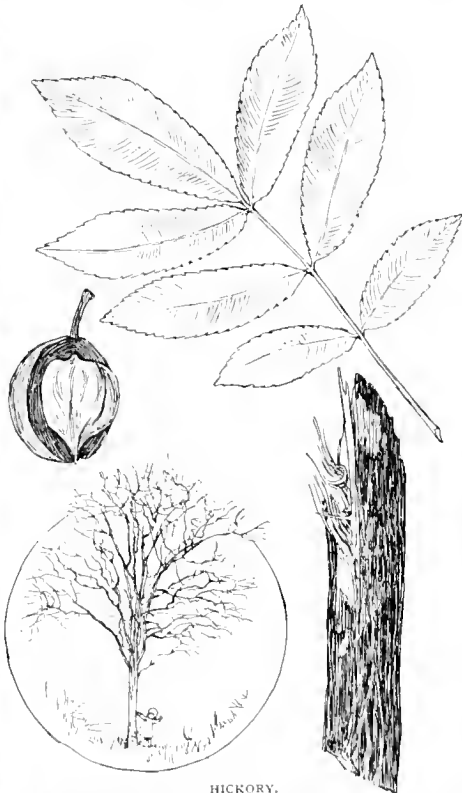

HICKORY.



BLACK WALNUT.



BUTTERNUT.



WHITE OAK.



WHITE MULBERRY.

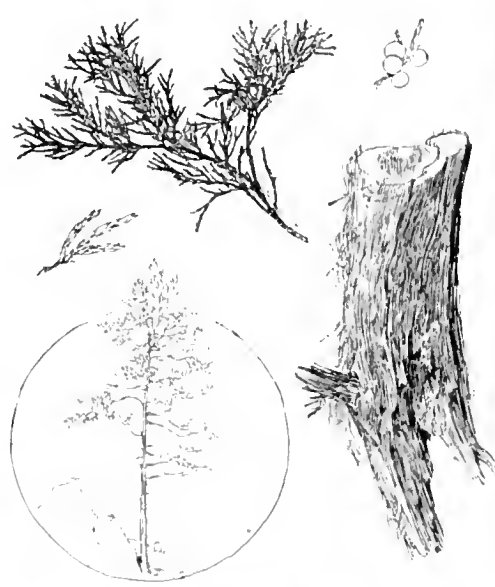

CEDAR.

ANIMAL PETS



BY THE LATE LIEUTENANT-COMMANDER E. W. STURDY, U. S. N.



ANIMAL pets have ever been a great joy to the average sailor. There is hardly a ship afloat that does not carry one or more such little favorites, to whom the crew are universally kind. More than this, there is frequently developed an attachment

between men and animals that is seldom to be seen on shore; and the intelligence displayed by these animals often far exceeds the wonderful stories we sometimes see in print. On men-of-war there is probably more consideration shown the crew in this regard than on merchantmen; at all events, you will find there many more ship's pets. It is by no means uncommon to see upon the same deck a dozen or more well-trained animals of various kinds whose natural homes are separated by thousands of miles.

The number and variety of animals brought home depend not only upon the countries visited, but to quite an equal extent upon the knowing how to take such care of each and every one that he will thrive in any climate and under conditions sometimes very trying. When we started forth in a certain ship on a cruise around the world, we had on board a black cat — every ship has a cat, and a black cat is supposed to insure good luck; a young Newfound-

land dog — quite a puppy he was then; and a very fierce-looking American eagle, the gift of one of the ship's visitors. This last we kept in a large cage, and for a long time he was treated with unquestioned respect, for his claws were sharp and his beak strong and forbidding.

From being suspicious of the intentions of any one who approached his cage, and almost resenting the offer of food and water, "Rocky" in a few weeks grew more trusting; and when the peculiarities of his appetite became understood by the crew he was so pampered in that respect that he would work his head from side to side in a knowing way, which plainly indicated that he appreciated the tidbits placed before him. Gradually it was admitted that he was under the special care of Tim Burton, for Tim had succeeded somehow in gaining Rocky's confidence to a greater extent than any one else. During the whole cruise, no matter what new pets were adopted on board, nor how interesting they might be in their individual antics, the crew remained so steadfastly loyal to Rocky that he never occupied other than the first place in their affections.

Of the black cat we really saw but little. He was known as "Erebus," and was friendly only with the captain of the hold, to whom he would come occasionally with a rat in his mouth, and ask in a cat-like way for some reward of his service in clearing the ship of one more pest.

"Rover," the Newfoundland puppy, grew rapidly in size and intelligence. He attached

himself to Andy Smith, the coxswain of the first cutter, and kept near him on all possible occasions. At meals he was by Andy's side at the mess-cloth, lying quietly until his food had been placed on a tin plate marked with his name. He never moved unless he was very hungry, when he would thump the deck a little with his tail until Andy gave him permission; then, dexterously taking the plate in his mouth, he carried it off some distance, and, without spilling the least particle on the clean decks, carefully ate his ration. When finished, he always licked his plate scrupulously clean and carried it to the mess-cook, whose duty it was to wash all mess-gear. We verily believed the dog thought he was helping the cook.

Rover had his own drinking-bucket, which was fitted, as ship's buckets are, with a rope handle. The place for this was in the manger, a small space forward in the bow. If Rover was thirsty he would get his bucket and carry it to the scuttle-butt, where he would stand until some one gave him water. When he had drunk enough he never failed under any circumstances to return the bucket to its place.

He knew the special bugle-call for the first cutter as well as its crew. If any other boat was called away he showed not the slightest interest; but let the bugler play the first bar of "The Girl I Left Behind Me," and Rover was up instantly, bounding toward the gangway.

Here he knew that Andy's permission

was reported ready, if the officer said, "No, Rover; you can't go," he would raise his paw to his head in salute and walk forward, his tail drooping ever so little with disappointment.



"LIMBER JIM" AND HIS WIFE

But if the officer said, "All right, Rover," he saluted in just the same way, and then in two jumps was in the bow of the boat, standing as erect and still as any figurehead.

The crew wanted a really intelligent monkey, and thought many times they had secured one; but after giving each a fair trial they sent him away as unworthy of admission among our ship's exclusive pets. One morning, however, a man returned from leave, bringing two lively monkeys, but one of them died soon after coming on board. As monkeys soon throw aside all shyness, it was not long before this new pet was well installed on the ship; and



THE HASTY FLIGHT OF "EKEBIS" AT THE SOUND OF THE SALUTING GUN

was of no avail. It was on the officer of the deck that Rover kept his eye. When the boat

"Limber Jim," as we called him, devised mischief enough to satisfy the most "larky" sailor.

There was one thing, however, that the monkey could never stand with calmness, and that was the firing of a big gun; he soon understood the preparations for firing a salute or for target practice. At such times he invariably scuttled off to the same spot under the fore-castle whenever the first gun was fired.

Limber Jim had a jaunty, substantial suit made for him, with the usual cap and fittings.

was a never-ending source of amusement. The many hues which this little animal is capable of assuming were practically shown us. He often took the color of an object on which he was resting; it might be a brilliant green or a sober brown—he adopted the shade at once.

In his normal state he was the most stupid, sleepy-looking thing in the world, showing no energy, but rather a supreme indifference to



THE CREW OF THE *AEOLUS* WITH THEIR PET GOAT IN THE FOREGROUND

Erebus shared with him this fear of any explosion. One day when the captain of the hold was preparing to go ashore, the ship saluted the fort at the harbor entrance. This so alarmed Erebus that he jumped from the berth in which he had been sleeping, and in a flying leap completely overturned the sailor's gripsack and scattered its contents on the bunk floor. The cat remained in hiding until the next day.

On the coast of Africa we made several additions to the ship's menagerie. A chameleon

what was going on about him. A peculiarity of the chameleon is the power of moving the eyes independently of each other, so that, with one looking ahead, the other may be observing something over the shoulder. On this account the new pet was called "Swivel-eye."

Up the Shat-el-Arab River, lying off Bus-sorah, whence Sindbad the Sailor set forth on his famous journeys, we had given us, as a great table delicacy, a young gazel. The little fellow was not more than two feet in height; his



ANOTHER OF THE KEARSARGE'S PETS.

eyes were large and brown and lustrous; his little horns and hoofs were as black and shining as ebony; his fawn-colored skin was like silk; his movements were the embodiment of grace. No one had the heart to contemplate killing such a beautiful creature; so when some men came aft to beg that they might have him to care for, he was at once given to them.

"Sindbad" was a name not quite suited to him, but the sailors chose it from associations with the place. He was beloved by every one.

Sindbad gave Rocky a good race for first place in the love of the crew, and I am not sure that in the officers' quarters he did not hold it.

The sailors of the United States battleship *Kearsarge* have had among their pets a goat and a bear. Bruin, or "Roosevelt" as the bear was named, would sit for hours on the rail, with his fore feet on the lowest round of the shrouds, and in the shadow of the boat above him would remain an interested observer of the men on deck at their work or play.



THE UNITED STATES BATTLE-SHIP KEARSARGE.



THE NEW DOLL.

'MERICAN doll-doll, how you do?
 Goldy-haired missy-doll, I love you.
 'Merican doll-doll, what 'oo say?
 "Little Jap missy *do* love play?"
 Pretty blue round eyes shiny shine.
 Very 'Merican dolly mine!

M. M. D.

HER VERY OWN.

(A True Story.)

BY FLORENCE A. PARDEE.

ONCE upon a time, there was a little girl named Helen. She lived in the country, and about her house there were many fine trees, where the birds came every year to spend the summer. Now Helen loved to watch the birds, butterflies, and bees doing their work.

Well, one day, Mr. and Mrs. Oriole came to look at the big elm-tree. They soon decided to build a nest there, and each flew off in a different direction to find building-material.

"Oh, papa," cried Helen, who had caught the gleam of brilliant orange and black, "let's help them, so they 'll stay here."

"All right, little girl," answered her father.

Helen had helped birds before by putting bits of string and worsted, and straws, on the ground and near-by bushes.

Suddenly she clapped her hands, exclaiming, "Oh, I'm going to label *this* nest, and then, after it's all built, it will be mine!"

So she carefully wrote her name on a tag of paper, putting a long piece of white string through the end of the tag. On some other tags she wrote the day and month, "May 28th." Then they were left in plain sight, and Helen scampered away.

The birds did not seem to notice the strings

at first, but later every one was gone, and from that hanging nest waved *six* little tags bearing Helen's name and the date!

When the birds had raised their families and had gone south, her father took down the nest and brought it into the house to Helen. Here is a picture of one of the orioles and the nest.



ONE OF THE "ORIOLES" AND THE NEST.

THE PRACTICAL BOY.

By JOSEPH H. ADAMS.

NINTH PAPER.

HIGH AND LOW TREE-HUTS.

A GROUND TREE-HUT.

For this a good stout tree is selected for the central support, and to it the roof-timbers are made fast. The hut can be made almost any size, but for five or six boys it can measure 10 feet across, with each of the eight sides 4 feet wide (see Fig. 1). Lay out a perfect octagon with

points, having them project, say, $6\frac{1}{2}$ feet from the ground; and with 2 by 3 inch timbers connect the tops of the posts and the angles with the tree, as shown in Fig. 8 on page 825, letting the top horizontal timbers project 1 inch beyond the posts.

The highest point of the slanting roof-joists may be 9 feet from the ground. Six inches up from the ground, nail a line of 1-inch boards 6 inches wide around the posts, and midway between these and the top line run another line of similar boards, but omitting one where the door will be hung (see Fig. 8).

The bottom of the hut should be floored over, and to do this embed short timbers in the ground, on which cross-timbers will rest so that the tops of them will be on a line with the top edge of lower line of timbers connecting the eight uprights. Where the middle line of timbers are attached to the uprights, each upright is cut away with saw and chisel, as shown at A in Fig. 7, so that the horizontal



FIG. 1. A GROUND TREE-HUT.

each of the angles an equal distance from the tree-trunk, and drive a stake to indicate each angle or corner. Dig a hole 2 feet deep, and embed a 2 by 4 inch joist at each of the eight

pieces will lap snugly against the wood. In joining use steel-wire nails.

The roof and sides are made of 4 or 6 inch matched boards driven together well, after

being left in the sun for a day or two to dry out thoroughly, so that they will not shrink or warp.

Use three or four simple sashes, as desired, and make an ordinary batten door.

The boards forming the roof should be laid across from timber to timber, and not from the sides of the hut to the tree; and, to make a tight watershed, tar-paper is to be laid on and tacked down, and afterward painted.

Where the roof joins the tree, a collar can be made of the tar-paper and tightly bound to the trunk with stout cord, the whole to be painted with the other roof-covering.

A circular table may be built around the tree, and fixed benches or other furniture and fittings may be used at the boys' pleasure.

A square hut is easier to build than an octagonal one, and one 10 or 12 feet square would accommodate quite a club of boys. Illustration B in Fig. 7 will give an idea for a hut of this kind.

A SINGLE-TREE HUT.

In the spreading branches of a large oak-tree a very snug roost can be made high above the ground, as shown in Fig. 2. This single-tree hut is 25 feet above the ground, and below it is a landing from which the rope-ladder is dropped. From this landing to the deck of the hut a stiff ladder is made fast both at top and bottom, and an opening in the floor of the deck will allow room to mount up on the deck near the door to the hut. As very few trees are alike, it

would be difficult to give a plan for the floor timbers among the outspreading branches; but from the illustration shown for the twin-tree hut in Fig. 6, some idea of the construc-



FIG. 2. A SINGLE-TREE HUT.

tion can be had for a single-tree hut. The main tree-trunk will, usually, have to project up through the hut, and the location in the tree should be selected so that the outspreading branches will form a support to the lower edges of the floor frame, as may be seen in Fig. 2. A peaked, a mansard, or a flat roof can be placed on the hut, depending on the main trunk

to give it support; and if the space in the tree will permit, a deck across the front and both



FIG. 3. A LOW SINGLE-TREE HOUSE.

sides will be very pleasant to sit on or walk about. The floor timbers should be well braced to the main trunk of the tree with long and short bracket-pieces as props, and where the lower ends are attached to the trunk large spikes should be driven in well. Cleats or blocks can be nailed fast under the ends also, as they will help to support and strengthen the anchorage.

Keep fire away from the tree-huts, and do not light any matches nor burn candles; for if once a fire is started, nothing will save your hut. It is too high to reach with a bucket, and, located as it is, a perfect draft will fan a small flame into a raging fire in no time, so that it is hazardous to use fire about any tree-hut.

A LOW SINGLE-TREE HOUSE.

FOR younger boys a low tree is best. An apple or maple tree near the house often affords a good support for a low tree-hut, and if the trunk is sufficiently heavy a house similar to the one shown in Fig. 3 can easily be constructed. The size of the house will be governed

somewhat by the size of the tree, which should be large enough to bear the weight of the house without straining it, particularly when there is a storm or high wind.

The construction of the frame is shown in Fig. 9. This is but a general idea, and will not apply to every tree; for trees vary in shape and size, and the huts cannot always be built square, as this one shows. The frame should be of 2 by 3 inch spruce, and the flooring-beams can be of 2 by 4 inch spruce, or almost any short pieces that can be had. One or two windows and a door can be arranged in the hut, and tar-paper tacked on the roof will make it waterproof. Access to the hut can be had by means of a ladder made from 2 by 3 inch spruce rails with hickory rungs or with 2 by 1 inch hardwood sticks securely nailed to the rails.

A LOW TWIN-TREE HUT.

A VERY serviceable twin-tree hut is shown below in Fig. 4.

To properly build this hut select a location between two trees from six to eight feet apart. With an ax clear off the brush and small branches for twenty feet up from the ground at the inside of the trunks where the hut is to be located. Obtain four or five pieces of spruce, hemlock,

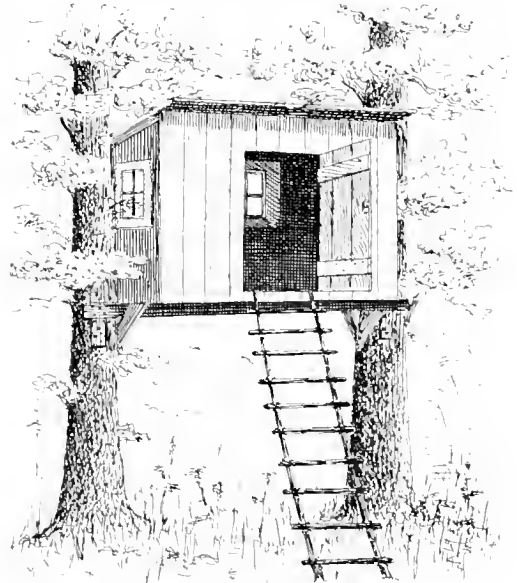

FIG. 4. A LOW TWIN-TREE HUT.

or other timber 2 by 8 inches and 16 feet long, and as free from knots as possible.

the length of the distance between tree-trunks. In the 6 foot pieces cut notches at the under

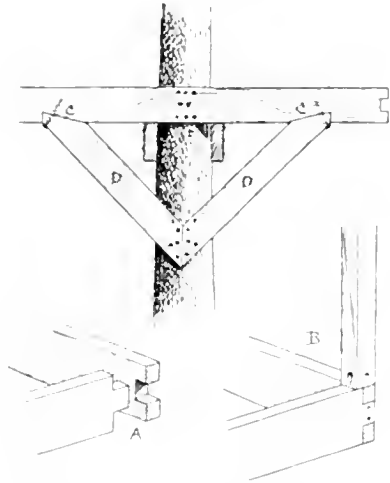

FIG. 5. DETAILS OF FRAMING OF THE BRACKET.

Saw off and nail two of these pieces to the trunks of the trees 8 feet above the ground, first cutting away some of the bark and wood of the trunk to afford a flat surface for the timbers to lie against on each side.

Six-inch steel-wire nails will be required for these anchorages; and under the timbers, and

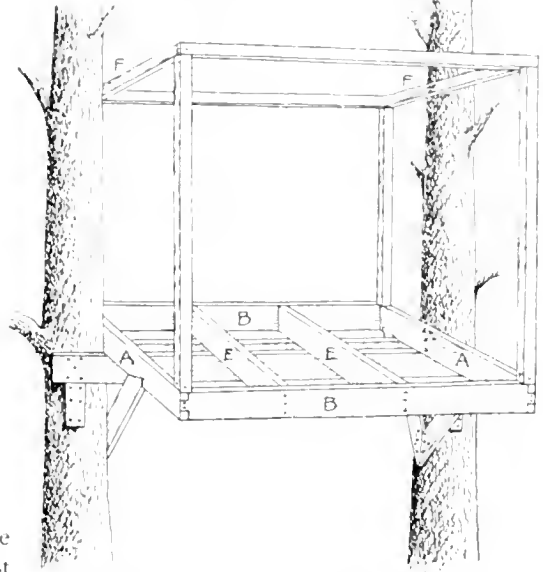

FIG. 6. DETAILS OF FRAMING OF A TWIN-TREE HOUSE.

side, as shown at CC in Fig. 5, into which the ends of bracket timbers DD will fit; and cut the ends of the timbers forming the square frame so they will dovetail, as shown at A.

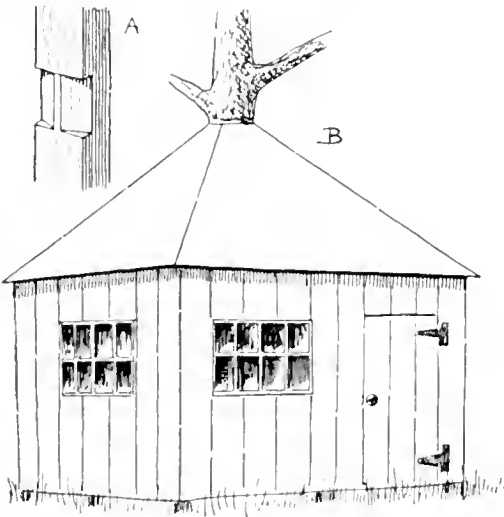

FIG. 7. A SQUARE GROUND-HUT.

lying flat against the tree-trunks, bracket-blocks, 2 by 8 inches and 15 inches long, are securely spiked to lend additional support to the cross-timbers. Cut two timbers 6 feet long, and two

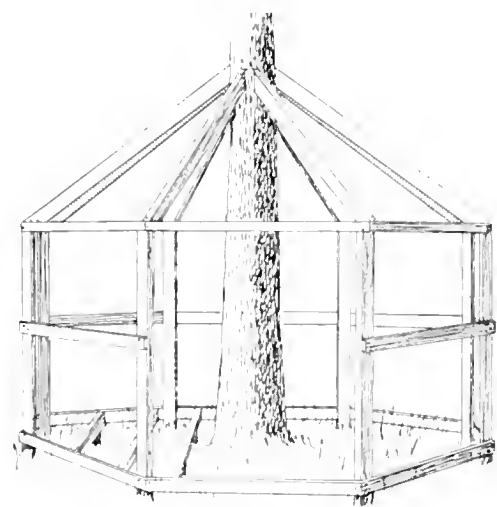

FIG. 8. FRAMING OF AN OCTAGONAL GROUND-HUT.

Spike the 6-foot timbers to the tree-trunks so that they will rest on the first two timbers that were nailed to the trees, and from the 2 by 8 inch wood cut four brackets, DD, and spike

them fast under each cross-timber so each tree will appear as shown in the upper part of Fig. 5. Place the remaining two timbers in position so that the ends will fit into those fastened to the trees, and nail them fast, as shown at B in Fig. 5.

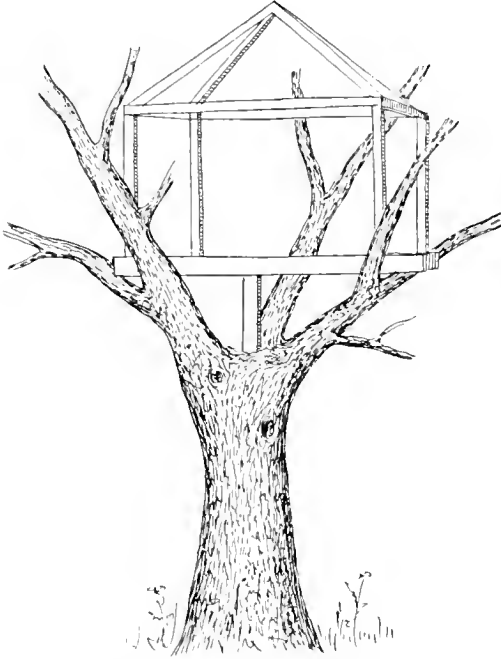

FIG. 9. DETAILS OF FRAMING OF A LOW SINGLE-TREE HOUSE.

Cut two more timbers, EE (see Fig. 6), and lay them across the supporting timbers, nailed to the tree, so that they will fit inside the front and back timbers BB, where they are to be well secured with long nails.

From 2 by 3 inch spruce construct a frame 7 feet high at the front, 6 feet at the back, and spike the side-timbers FF, forming the top, to the inside of the tree-trunks.

The bottoms of the uprights are to be mounted on the corners of the floor frame, as shown at B in Fig. 5, where four long nails will hold them securely in place.

Cut two timbers and arrange them in an upright position at the front, thirty inches apart, where the door will come; then half-way between the floor and top of the framework run a line of timbers all around, except between the door timbers, and spike them to the trees.

For the sides, floor, and roof use matched boards planed on both sides.

Over the roof a thickness or two of tarred paper is to be laid and fastened down at the edge with small metal washers and nails. Shelves, benches, and table may be built in the hut as required. Put in windows as needed.

If exclusiveness is desired, use a rope ladder or one made of light hickory poles with lashed rounds — the ladder in either case being hauled up when the owners are “at home.”

A TWIN-TREE LEAN-TO.

IN Fig. 10 is shown a simple form of hut built upon the ground, relying upon two trees for strength and firmness. It is built substantially as is the low twin-tree hut, except in the matter of flooring, which may follow the plan of the house-tent shown on page 713 of the June number. This twin-tree lean-to will be found a very serviceable hut, and is very easily built and at a low cost. If rather thin saplings are chosen for the supports, the swaying in a high wind may loosen the joints in the house. If there are no stout trees, and such lighter ones have to be used, it will sometimes be found advisable to “guy” them to other trees to make them stiff. In fastening down tar-paper on the roofs, care should be taken to use the tin

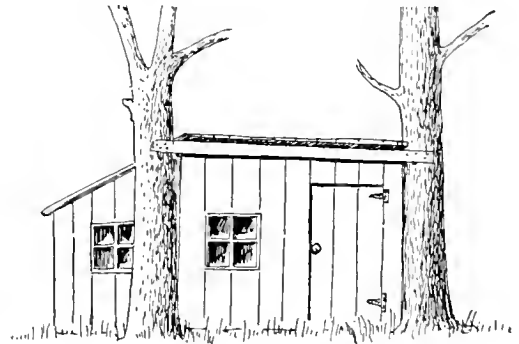

FIG. 10. A TWIN-TREE LEAN-TO.

washers that come for this purpose; or, if these are not to be had, nail down over the joints ordinary lath, letting the same nail answer for both the lath and the tar-paper. If these or similar precautions are not taken, the paper will, in a high wind, pull through the nail-heads.

1
CONCORD

2
LEXINGTON

APRIL 19TH
1775.

17
YORKTOWN

19
COWPENS

3
BUNKER HILL

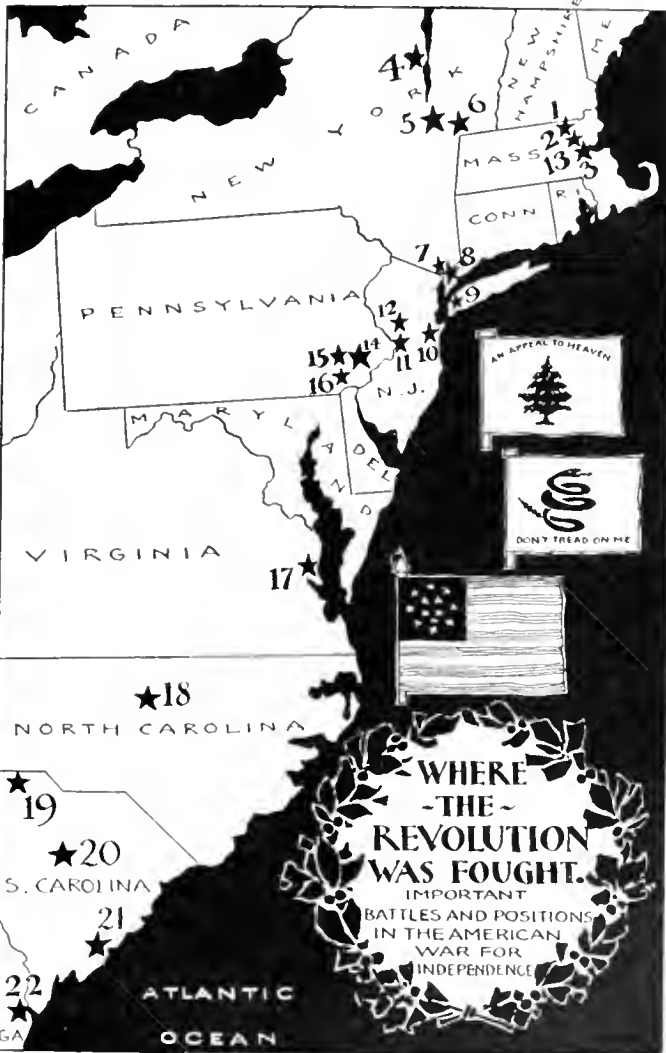

22
SAVANNAH

13
BOSTON

18
GUILFORD C.H.

11
TRENTON

20
CAMDEN

9
LONG ISLAND

21
CHARLESTON

7
F-WASHINGTON

8
NEW YORK

12
PRINCETON

10
MONMOUTH

6
BENNINGTON

15
VALLEYFORGE

4
TICONDEROGA

5
BEMIS HEIGHTS

OCT. 19TH
1781.

16
BRANDYWINE

14
GERMANTOWN

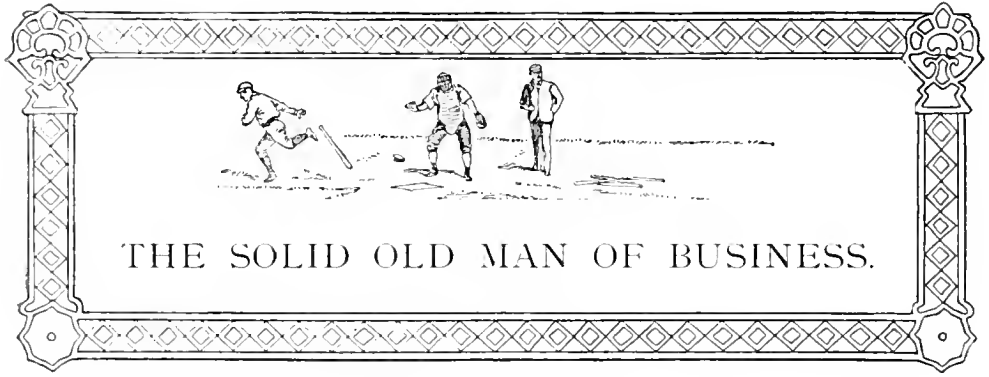

By WALTER CAMP.

THE solid old man of business sits in his chair
 in his down-town office;
 And he 's prone to inquire,
 Is this good old esquire,
 How his boy is doing at college,



"IN HIS DOWN-TOWN OFFICE."

As he sees in the lines of his "Post" and his
 "Times"
 The growth of a new,
 And he doubts not true,
 Queer-fangled athletic knowledge.

This irate old man of business growls in his
 chair in his down-town office;

And his temper grows sore,
 As he ponders the more
 Upon what he has read in the papers
 Of the foot-ball match, and the base-ball
 game,
 And th' unusual stew
 Kicked up by the crew,
 And tennis and other capers.

Then the sage old man takes a notion to leave
 his chair in his down-town office.
 With a curt "Short trip!"
 He packs up his grip,
 And a train he takes for the college.
 Then he scans his "Times" for a base-ball
 date,
 And he chuckles a bit
 When he finds he has hit
 Just the time for acquiring knowledge.

This clever old man to the ball-ground drives.
 In the grand stand soon he 's sitting,
 And glancing down,
 With a sinister frown,
 Toward the uniformed boys on the
 bases.
 He knows not the game, but his neighbor
 does,
 And insisting to tell,
 The youth posts him well,
 Naming over the brown young faces.

But the dark old man only frowns the more
 as the game goes through eight innings,
 And only one more
 Remains, while the score

Brings ten innings close into vision;
For the visiting nine goes out "one, two,
three,"

And also "one, two,"
Of the side in blue,
And the third takes up his position.

The solid old man of business gives a start as
of recognition

At his neighbor's cry;
"Now hit it, Si!"

And the batsman swings all his muscle —
What a cheer goes up as the ball shoots
out,

And far over the head
Of the fielder in red
It sails, while above all the noise and
bustle

A wild old man of business yells as he leaps
on his bench in the grand stand —

"Hooray! hi! yi!
A home run, Si!"

I tell you that that youngster's mine, sir!
Silas W. Brown — I'm S. Withington
Brown —



"HOORAY! HI! YI!"

I'll give him a dinner,
That fine young sinner, —
Yes, him and all of his nine, sir!"





FIRST AID TO THE INJURED.

BY DR. E. E. WALKER.

III. DROWNING.

As the boys had not been on the river very many times, they begged Mr. Wilson to let them hire a skiff and take a row by themselves. They said they would take Abe, and they *knew* they would be safe. So for once their guardian was over-persuaded. The plan was to row up the river for two or three miles, as that would be the hard work, and then they could float down with very little effort. Their skiff was rather large and flat-bottomed, so there was no danger of overturning, even though they had to look out for the big waves made by the steamboats going up and down. Abe entertained them on this trip by telling them about the life on the river, and naming the different towns and villages they passed.

They rowed or almost floated down the river. It was sunset, a glorious sight on the Ohio. The river was higher than usual at this season on account of recent heavy rains, and the current ran swiftly as it neared the island. There was a dam built from the mainland on the eastern shore out to the upper end of the island, and before the boys realized the force of the water, they were being swept down upon this wall of stones. Abe, although courageous, was very excitable; and though he pulled with might and

main to turn the boat out of the current toward the other side of the island, it was fast getting beyond his control when, suddenly, one of his oars, hitting the trunk of a tree that jutted out of the water, slipped out of his hand and the boat veered sidewise in its hurried course down the stream.

“Thæthar’t’h ghoht, but we ’re loht!” lisped Abe, his face the color of his mother’s apron.

On the boat hurled until it struck the dam with such force that Abe, who was standing up in his excitement, was thrown into the water. Although he had lived by the river all his life, Abe did not know how to swim, and down he went, to the terror of John and Jerry, who were sitting quietly in the boat. Mr. Wilson, who had been watching them through his spy-glass all the way through their trip, rushed out on the bank and forded the dam just in time to rescue Abe, who was

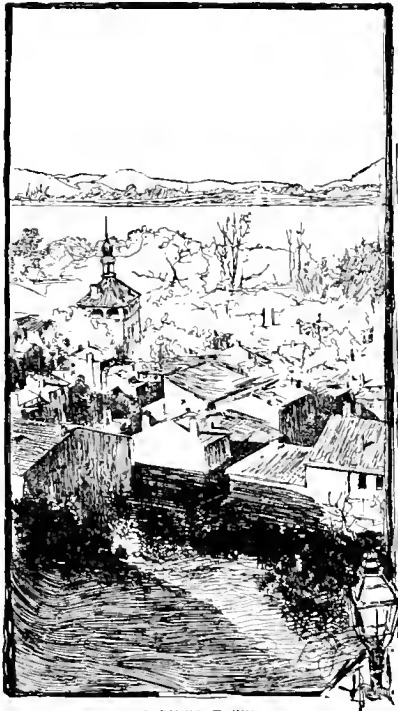

A RIVER TOWN.

choking and gasping in the water. He dragged him out and laid him on the bank, and began to work over him, for Abe by this time had lost consciousness. The boys sat quite still in the boat, as Mr. Wilson directed; for after it once struck the dam it came to a standstill, only knocking against it as it was driven by the

waves. With the help of an obliging negro from one of the shanties on the shore near by, the boat was soon dragged round to the shore and the two boys landed in safety. In the meantime Mr. Wilson had turned Abe over on his face to let the water out of his mouth. By the time the boys reached him he had turned him over on his back, and had rolled up a blanket and laid it under Abe's shoulders so that his head hung low. He loosened all the clothing around his neck, chest, and waist, and put his finger into his mouth to see that his tongue had not fallen back in his throat to stop his breathing. More quickly than it takes to tell it, Mr. Wilson then dropped on his knees behind Abe's head, seized both of his arms just above his elbows, and swept them around on the ground in an arc of a circle till they were stretched away above his head. He held them there a few seconds, pulling on them, and then swept them back again, pressing them in against the ribs. He did this slowly and regularly, just about as Abe would breathe; and in two or three minutes the boy's eyelids began to quiver, and he drew a short breath. Mr. Wilson then rubbed him thoroughly and wrapped him in warm blankets which the boys had brought down from the camp. John also made a cup of hot coffee, which Abe was soon able to drink, and then they took him to the camp. In about an hour he was ready to go home, and Mr. Wilson rowed him across to the Ohio side.

When the boys were eating supper that night, Jerry said: "Guardie, why did n't you roll Abe on that barrel that was down there on the shore? I thought that was always tried first when anybody was 'most drowned."

"Not at all. I once knew a man whose ribs were broken by being treated so roughly."

John asked: "But, guardie, why did n't you carry him up to the camp first?"

"Because he might have died before we got him there. The first thing to do, when a person is almost drowned, is to start his breathing again."

"You mean to pump air in and out of his lungs, the way you did with Abe?" said Jerry.

"Yes, that is really it; for when the arms come up the air goes into the lungs, and when the hands are swept down and pressed against the ribs it squeezes the air out."

"I think it would be jolly fun to try it when a person is n't drowned," said John.

"It would not be a bad plan for you boys to practise it on each other," said Mr. Wilson.

"And then we could rub each other with our hands, and have a cup of coffee, could n't we?"

"You might, if you did n't practise too often," said guardie.

"I wonder what Abe's mother said when she saw him with my clothes on," said Jerry. "It's lucky we were near the camp and could get some good dry ones."

"But, guardie," said John, "why is it that you are always hearing about good swimmers getting drowned?"

"It's generally because they are taken with cramp," said guardie. "You know how hard it is to come out of the water when you are down at the sea-shore; and you know how your father insists on your not staying in swimming more than ten or fifteen minutes. Well, this is largely on account of the danger from cramp; for when you stay in the water too long you are apt to get chilled; then the cramp comes on and makes the best swimmer utterly powerless."



"AMONG THOSE PRESENT"
AT A YOUNG FOLKS' COSTUME PARTY.



FROM THE DAYS OF THE DIRECTORY.



IN GRANDMA'S CAP AND GOWN.



A BASHFUL BRIDESMAID.



A LITTLE HARLEQUIN.



THE MINUET.



A COLONIAL DAME.



MISS WIGGS OF THE BERRY PATCH.



THE PRINCESS AND THE PAGE.

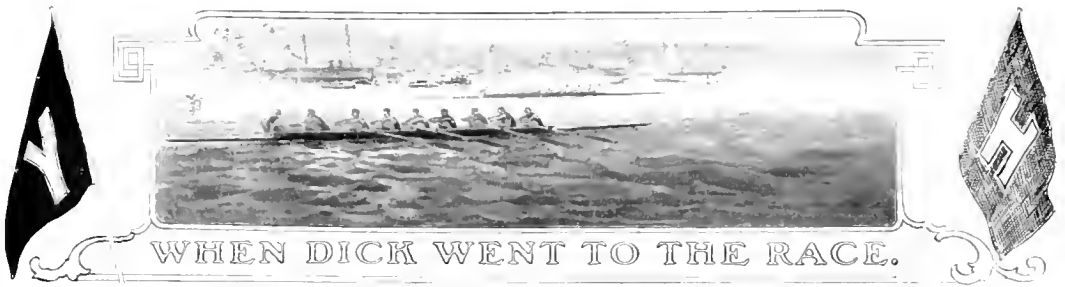

WHEN DICK WENT TO THE RACE.

By ELSIE CARMICHAEL.

DICK tried to choke back the tears as he turned away from those hard-hearted relatives of his and looked over the brilliant flower-beds and velvety lawn to the blue Sound, where white yachts were flying by under a stiff breeze, bound for New London. He had set his heart on going to the Yale-Harvard regatta, and he was bitterly disappointed.

"Mother, we can't take that baby," Donald had said. (And oh, how it had cut—"that baby"!)" "We had all we could do to get tickets on the observation-train for our own crowd, anyway, and we could never get another anywhere near us; and, besides that, he would get all tired out in that big crowd. We could n't *think* of taking Dicky."

Isabelle, Dick's big sister, dropped a light kiss on his tear-stained cheek as she went to the carriage, and then they all drove off gaily to the Pequot, where they were going to lunch before the race.

"I'm a Yalesey," sobbed Dicky. "And I want to go to the rogatto, *please*." But the older ones were firm.

"Dick, when you are older you will have plenty of opportunities to go," said his mother. "Next year perhaps we can manage it."

"Besides, Dick," his Harvard uncle tried to comfort him. "Yale *is* n't going to win this year, and you would be disappointed."

But Dick refused to be comforted. Slowly and sadly he dragged one foot after the other down the garden path to the beach, where the blue summer sea rippled in tiny waves up the sands. He looked with longing eyes off toward New London, and watched the yachts dip and rise as they tacked into the harbor. Every one in the world, it seemed, was going to this particular Yale-Harvard race except Dick.

The *Kelpie*, a new St. Lawrence skiff, was lying beside the float, and Dicky climbed over the side and flung himself down in the bottom so that he could not see the steamers and launches and craft of all sorts going by to New London; but as he lay there on his back and gazed at the sky, the white clouds drifting by looked so like the white-sailed yachts below that he shut his eyes to keep from seeing them.

The *Kelpie* rocked gently on the little waves, and at last, lulled by the gentle motion and soothed by the warm sun, Dick must have fallen asleep; for, the next thing he knew, he heard shouts above him, and, opening his eyes, he sat up suddenly in the boat. All around him were big waves on which his little skiff rode like a feather. Almost over him was a great white yacht whose brass rails glittered in the sun. From masthead to deck it was strung with little fluttering blue pennants, and the men who crowded to the rails wore bachelor's-buttons in their buttonholes and carried big flags with Yale on them in letters a foot high.

"Well, young chap, you had a close call," said one of them as Dick was carried up on deck. "In another minute we would have run you down, unless you had stove us in first. What do you mean by not looking out for small craft like us?" He spoke seriously, but Dick caught a merry twinkle in his eye, and liked him at once.

"I guess I went to sleep," he explained. "I wanted to go to the rogatto to see the Yaleseys win, and they would n't take me, so I went to sleep in the boat, I guess. I don't know how I got here. I'm a Yalesey, and I wanted to see the rogatto," he wound up.

"That 's the right stuff!" cried the big fellow in the white yachting-suit. "Let 's give him a

three times three." And such a tremendous cheer floated over the water that the people on the near-by yachts looked over smilingly as the big *Sea Queen* swept along.

Dicky very soon felt perfectly at home with these men, some of whom knew his brother Don well; and they were delighted with the manly, well-set-up little chap, with his handsome frank face and his eyes of true Yale blue.

"We'll send word to your mother from New London," explained Richard Brent, whom Dicky looked on with awe, for some one had whispered to him that he was the captain of the foot-ball team, and Dick knew what that meant. "But I don't see but that we will have to take you to the race with us. It will be all right, old man; I'll explain to your mother and Don."

Dick's shining eyes were answer enough, for he could n't speak, as a big choke came in his throat.

"That 's all right," Brent said, patting him on the shoulder, while Dick swallowed hard. "And now make yourself at home. We are going up to the Quarters for a little while, as the race won't be rowed until afternoon. I hope you don't mind."

Mind! Dick's heart was thumping up and down in his chest. He could feel it. To see the race was marvelous, but to think of going up to the Quarters, where these great men lived, was almost too much to be borne like a man.

Then they sailed into New London harbor, crowded with yachts with glittering brasswork and fluttering pennants of crimson or blue. Over the water came at intervals the long-drawn cheer of Harvard, and again the quicker cheer of Yale. Bands played on the big excursion-steamers, and as they steamed down the long avenue of anchored yachts they were greeted everywhere by vociferous Yale cheers, for their yacht was recognized, and, though Dick did not know it, they were a very important part of the show. Many eyes were turned admiringly on the handsome boy standing high in the bow waving the big blue flag, while Captain Brent of the football team held him secure with one arm around his shoulders.

It was all the most wonderful sight Dick had ever seen—the hundreds of gaily decorated yachts and launches and steamers loaded with

people, the music, the cheering, the excitement of it all. Soon they left it behind them, however, as they steamed up the broad river toward the point where the big blue flag waved gaily in the breeze. Captain Brent pointed out the cozy red-roofed Harvard Quarters on the bluff as they passed, and Dick looked rather pityingly toward the big fellows in white sweaters who were loafing about the float, for he knew they were to be beaten, of course.

Up at the Yale Quarters they were greeted with tremendous cheering, and the crew came down to the dock to welcome them. Proudly Dick stood like a figurehead at the bow, waving his huge flag; and then one of the biggest and most splendid-looking of the men came up to Brent and him, holding out his hand.

"Are n't you going to introduce me, Brent?" he asked in a grand sort of way Dick loved, and Brent said:

"Dick, I want to introduce you to Captain Goodwin of the Yale crew." Dick shook hands shyly. This was the greatest moment of his life. With big, shining eyes he stood there with Brent's arm round him, while the two greatest men in college discussed him.

"You see he is the true Yale stuff," announced Brent. "He was bound to see us win, and he just came willy-nilly. He is the kind we want. Let 's see, Dicky, boy, what 's your class?" he asked.

Dick blushed. "1920," he said promptly. He and Don had worked it out.

The men roared. Then, seeing the serious look in Dick's eyes, they straightened their faces.

"That will be a fine class, I'm sure," said Goodwin. "Now, my boy, I want you to meet my men"; and so Dick, striding along between the two big seniors, went over to the group of crew-men and was solemnly introduced to each in turn.

"He is booked for 1920," explained Goodwin. "And some day he is coming up here to Gales Ferry to pull a good oar for old Yale."

"In the meantime he is going to be our mascot," cried the stroke-oar. "Here!" He picked up a blue sweater with a big white Y on it, and pulled it over Dick's head. It came down to his feet, but they rolled it up and turned back

the sleeves. Then on his fair head they placed a blue cap with the crossed oars of the Varsity crew, and then Goodwin swung him to his shoulder, Dick still grasping his big Yale flag.



"HE LIFTED DICK TO HIS SHOULDERS."

"Now cheer for 1920 and Dick Ordway," he cried, and the cheers that came from many throats nearly deafened Dicky.

"Bring us good luck," they cried after him,

as Brent carried him back to the yacht. "It depends on you now, Dicky, to bring us good luck in the race."

The rest of that afternoon was like some bewildering dream. They steamed down the beautiful river, passed the gay yachts again, and dropped anchor near the finish. There was a jolly lunch served on deck, with Dick at the head of the table in his big Yale sweater; and then, toward late afternoon, the excitement grew intense. The guns were fired more often, the cheering was continuous, and the bands played "Fair Harvard" and "Here's to Good Old Yale" louder, trying to drown each other out; and all the time the sun was dropping lower, until it hung just above the hills across the river.

Dicky, on the bridge of the yacht with Captain Brent and some of the others, peered through the huge binoculars up the river, just as he saw the other fellows do. When the gaily decorated observation-trains wound up each shore toward the starting-point, Dick wondered proudly what Don and Isabelle would think if they could see him now. Then the noise became deafening; the cheering burst out again and again; the bands played louder.

"They've started!" Brent said in a low, tense sort of way, and Dick felt the arm about him tremble a little.

Nearer and nearer came the two specks down the long path of water between the yachts, the oars of the crimson and the blue flashing rhythmically as they came. Suddenly Brent dropped his marine glasses. "Harvard's ahead!" he groaned. "Come, get together, boys, and cheer as you never cheered before. Keep it up even if you are dumb forever after. We've got to win!"

He lifted Dick to his shoulders. "Bring us good luck, Dicky," he pleaded.

"Oh, yes, we're going to win," Dicky announced confidently.

Nearer and nearer they swept, those two white bird-like shells, Harvard plainly in advance by a good boat's length. But not for an instant did the men on the *Sea Queen* show to others any discouragement. Clear and strong rang out the Yale cheer over and over again, and above the

deep "Rah, rahs!" came a high, piercing, sweet child's voice. It was Dicky, cheering for his future Alma Mater.

Whether they took heart from the steady cheering of their men, or whether the Harvard men had rowed themselves out—at any rate, the Yale shell forged ahead suddenly, and when they were opposite the *Sea Queen* the two boats were "neck and neck."

Dick almost jumped out of Brent's arms. "Go it, go it, go it!" he shrieked high above the deep roar of the cheering; and, as though in answer to their little mascot, the Yale crew, in one mighty spurt, shot ahead and crossed the line, a winner by only a few feet.

And then bellam reigned. Every one went wild, and amid a deafening roar of booming cannon and bands and cheering spectators the Yale crew went aboard their launch and

steamed up the river. As they passed the *Sea Queen* they slowed down and waved their hands.

"You are a good mascot, Dicky," Goodwin shouted. "You helped us win." And then, tired as they were with their long pull, the crew gave a last cheer with Dick's name on the end.

Then it was all over, and the *Sea Queen* sailed out into the harbor toward the open Sound, while a fairy sea of green and rose spread out around her in the sunset glow, and the spires and chimneys of New London were silhouetted black against the fading crimson of the sky. Out toward the Sound it was all pale and misty and mysterious, but behind her the yachts were glittering with lights like jewels, as one by one they glided through the great drawbridge and made for the open Sound, and took their mascot to his home. And so everybody was glad that Dicky went to the race.



HOW THEY CELEBRATED.

BY EDWIN L. SABIN.

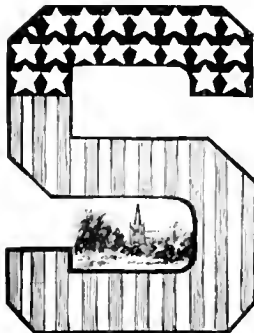

Said the belfry: "Clang! Clang!"

Said the crackers: "Rap! Rap!"

Said the brass cannon: "Whang!"

Said the torpedoes: "Snap!"

Said the sky-rockets: "Whizz!"

Said the candles: "Sh! Piff!"

Said the small pin-wheels: "Fizz!"

Said the big ones: "Whir! Wiff!"

Said grandma: "There, there!"

Said father: "Boys! Boys!"

Said mother: "Take care!"

Said cook: "Such a noise!"

Said Puss: "Gracious me!"

Said Towser: "Bow-wow!"

Said Susie: "Wee-ee!"

Said Will: "Hurrah! Ow!"



THE CHUCKIE WUCKIE STORIES:

BY ISABEL GORDON CURTIS.

THE first thing everybody says when meeting Chuckie Wuckie is, "Why, what a funny name! Who gave it to you?"

And Chuckie Wuckie always answers, "My papa found it for me."

"Why did he give it to you?" they ask.

"Because he says I look just like a Chuckie Wuckie."

"But what is a Chuckie Wuckie?" everybody persists in asking.

"I don't know," Chuckie Wuckie answers gravely. "My papa says there is n't any other Chuckie Wuckie in the world—that he knows of, at least."

When "old peoples"—that is what Chuckie Wuckie calls her mama and papa—when "old peoples" let their memories go back to the days when they were "very little peoples," they always remember that it was the "really, truly stories" they loved best. Fairy-tales were beautiful and giant-stories were exciting, but it was the stories mother and father told of little boys and girls they had once known, and of little cats and big dogs they had loved, which were the very best of all. For this reason, I want to tell you, before you read any of the Chuckie Wuckie stories, that Chuckie Wuckie herself is real, and her papa and mama are real, and everything I have written about her is true.

THE "I LOVE YOU" STORY.

ONE summer it grew very, very hot, and the doctor advised Chuckie Wuckie's mama to take

her up in the mountains where the air was cool. Papa could not go with them, because he had work to do at his office, so mama and Chuckie Wuckie prepared to go alone.

"Dear, dear!" said Chuckie Wuckie one afternoon, while she sat watching her mama pack the trunks—"dear, dear! Poor papa will be so lonesome!"

"Yes, we do wish he could go with us. We



"CHUCKIE WUCKIE WENT AWAY TO HER OWN LITTLE DESK IN HER OWN LITTLE ROOM."

would all enjoy our holiday so much better," said mama.

"He won't forget we love him just as much,

will he, if he thinks we are having a good time where we are and he is working down in the dusty old city, all alone, where it is hot?"



"INSIDE EACH SLIPPER WAS ANOTHER LITTLE 'I LOVE YOU!'"

"No, indeed," said mama; "he won't ever forget we love him. We will write a long letter every day and tell him everything we do."

Mama went on folding little frocks and petticoats, rolling stockings into little balls, and tucking wads of tissue-paper about little hats. Chuckie Wuckie sat very quiet for a long time; then she said, "Mama, will you please show me how to print 'I love you'?" You know I can make all the letters nicely, only I don't know how to put them together into any words, except 'dog' and 'cat' and my name."

Mama laughed. "Of course I will, dear," she said. "It is a very easy little sentence, and you can write it without any trouble."

Chuckie Wuckie brought a pencil and paper; then mama sat down beside her and printed "I love you" in beautiful, clear, big letters.

"Now, suppose I print it in French. Here it is: 'Je t'aime,' just as Georgie would say it."

"Georgie would n't say it, though, mama, because you know we have n't been friends since he poked my doll Jessie's eyes out."

"I had forgotten that," said mama.

Chuckie Wuckie went away to her own little desk in her own little room. For two hours, while mama was packing and arranging things round the house, the little girl sat cutting out bits of paper and writing on them. Mama was glad to have her busy, because she had so much to do.

Next morning they went away on an early train to the mountains, and with the last hug and kiss which Chuckie Wuckie gave to her papa, she whispered, "You won't forget how much I love you?"

"Papa can never forget that," said her father, with a big laugh and a tight squeeze.

Then the choo-choo cars came along with their great noise, and papa was left on the platform waving to a little girl who was throwing kisses at him from the window of a car. On Monday morning Chuckie Wuckie received her first letter from papa. Here is what it said:

AT HOME, July 15.

MY DARLING CHUCKIE WUCKIE: I have been very busy since you went away; but I must tell you what happened after you had gone. When I came home Tuesday night, I found under my ink-bottle on the library table a little slip of paper, and printed on it in great, big letters was, "I love you." Tucked into my pen-wiper was another little "Je t'aime." Inside each slipper I found a little "I love you." Tucked under my blotter was another "I love you." I had to open the telephone-book, and a little "I love you" fell out of it. There was a dear little "Je t'aime" in all my dressing-gown pockets; "I love you" curled about the handle of my tooth-brush, and another was in my match-box. When I went to bed I found "Je t'aime" and "I love you" all over my room — in the bed, under the pillows, everywhere! Why, there was a "Je t'aime" among my collars, and "I love you" through my neckties! It rained the next morning, and a tiny "Je t'aime" fell out of my umbrella. There were bits of paper which said, "I love you," in my rubbers. I'll keep finding "I love you" in some new spot every day till you come home, and every one of them printed by your own dear little hand. What a clever little thought it was to make a poor, lonesome old papa feel happier! No other little five-year-old girl but my Chuckie Wuckie would have thought of it. Now, I must say good-by, with a great, big "I LOVE YOU!"

FROM PAPA.

Nature and Science

for Young Folk;

Edited by Edward F. Bicklow.

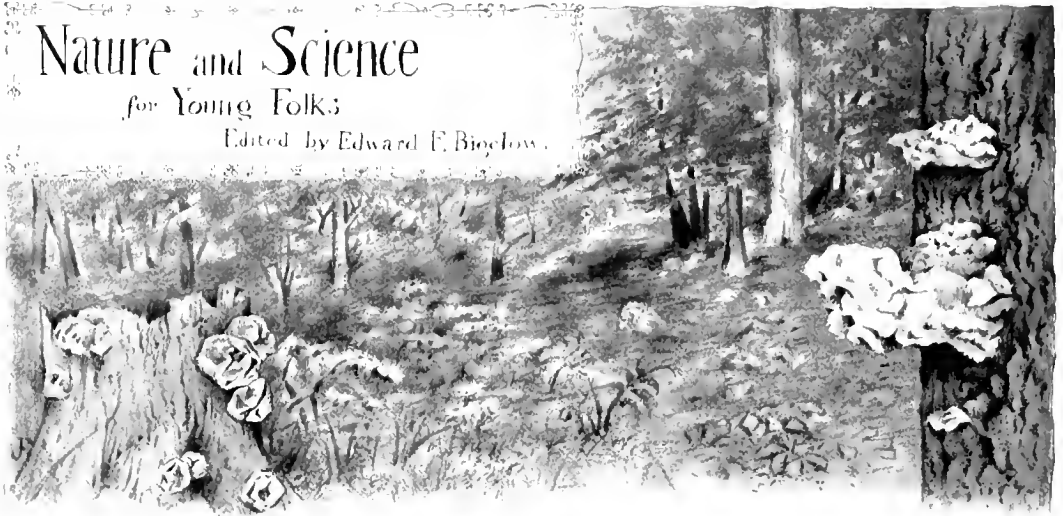

Puffballs.

"GOING THROUGH THE WOODS IN SUMMER"

Polyporus sulphureus.

THE FUNNY FUNGUS FAMILY.

GOING through the woods in summer, we often find beautiful bits of a low form of plant growth called Fungi, branching like brackets from the trees, covering old stumps, or poking their dainty heads through the dead leaves at our feet. Many more may be found, by careful searching, hiding themselves behind the grasses and leaves. We exclaim with delight at their exquisite forms and colors. We can admire—but beware! Don't eat. There, perhaps right in your path, is that innocent-looking Death's-cup, the deadly *Amanita*, most poisonous of all the mushrooms. So easily are the poisonous ones mistaken for harmless kinds, it is a safe rule for young folks never to eat of specimens, but just

study them and admire their beautiful colors and forms. A swelling of the stem at the base, hidden partly or often wholly underground, is always a dangerous sign.



"WE CAN ADMIRE—BUT BEWARE! DON'T EAT!"
(*Amanita phalloides*.)

Strange to say, the Death's-cup closely resembles the one most eaten of all the meadow mushrooms,—our common table mushroom,—which, however, is cultivated, the supply for the markets being not usually obtained from those found growing wild. The growth of a mushroom is interesting. A good one to study is the common table mushroom, as it has characteristics common to all the Fungus Family.

The first we see is the tiny



THE GROWTH OF OUR COMMON TABLE MUSHROOM.
(*Agaricus campestris*.)



"WE PICKED UP, ONE DAY, A FROST-BIDEN STICK COVERED WITH DAINY CUPS."
(*Sarocypha floccosa*.)

button-like form pushing its head above ground. This, as it grows taller, swells and expands at the top into a bulb-shaped body; and soon, on the under side, we see a break in the skin or veil. The top keeps swelling and the skin splitting till we have the gills in sight, stretching from outer edge of cap to top of stem. Their entire surfaces are covered with minute club-like protuberances which hold and scatter the tiny dust-like particles or spores, just as flowering plants do their seeds. This is the mission of our mushrooms, for what we see above ground is only the fruiting body—the real body of the plant lies underground. Let us follow one of those minute spores down in the rich, moist earth. It swells, absorbs food through its walls, and divides into two cells. These again swell and divide until we have a tangle of white thread-like substances called the mycelium—the real body of the plant. At many

points the threads mat together, forming tiny knobs which increase in size and push upward until they break the soil and look out upon our world, where they soon become the familiar parasol-shaped mushroom. How strikingly different are fungi from other plants! They have no green leaf, and none of that wonderful green coloring-matter, chlorophyl, which takes carbon from the air and hydrogen gas and oxygen gas from water and forms them into food for the plant, so making it an independent being. As the Fungi lack this, they must get the food already made by some other plant or animal. That is the reason we find them attached to trees, logs, anything that will furnish them with the desired food. Many forms look like flowers and are just as beautiful.



"THAT BROWN-LOOKING CORNUCOPIA."
(*Craterellus cornucopioides*.)



"IN THE FIELDS OR ON THE EDGE OF THE WOODS, THAT IS CALLED THE FAIRY RING."
(*Marasmius oreades*.)

We picked up, one day, a branched stick covered with dainty cups, bright red inside, on their tall, curving stems; and I certainly think it ought to be called the Flower Fungus instead of that long Latin name which no one can remember. When we see that brown-looking cornucopia coming out of the ground, it seems as if some of the Christmas candles ought to be inside. Probably we have all seen, in the fields or on the edge of



SHAGGY-MANE
(*Coprinus comatus*)

the woods, that circle called the Fairy Ring. Before fairy folk came to be doubted, it was firmly believed these rings were the dancing-ground of the fairies. In the moonlight the sprites danced, wearing down the grass under their feet—at least so our grandfathers said, but we must take science's simple explanation of it. A fungus plant will soon exhaust all the fungus food from the soil beneath it, so that only the spores which fall outside this barren spot will take root and flourish. So the ring is always widening outward, forming a perfect circle unless something interferes with it. The rings are abundant in wet weather, of a buff color or reddish. In the



"IF YOU TOUCH IT, WILL SHAKE
LIKE A BOWLFUL OF JELLY."
(*Tremella fuciformis*.)

vast family of Fungi, about thirty-eight thousand kinds of which are known to botanists, there are many queer varieties, as the Shaggy-mane or Horsetail mushroom. These are such rapid growers you can hardly believe your eyes in the morning to see a whole patch of them where there were none the night before. Their coloring is gorgeous, the gills being a deep salmon-pink and the spores black; the latter, when mature, dissolve into a

black fluid which drips from the cap. This fluid was used for writing-ink when people made their own. Another peculiar fungus is the delicious Morel; and you will have no trouble in knowing it, so different is it from any other, with its dark-brown pits covering the entire outer surface. A beautiful white form is the Trembling Fungus, which, if you touch it, will shake like a bowlful of jelly. It is very soft and grows close to the ground. Perhaps the handsomest of all is the Coral Fungus. Its name describes it well in color, shape, and growth. Found all over the world is the Earth-star, beautiful in its oddity. You can tell what the weather will be by it, for it is nature's barometer. When you see it spread



"THE DELICIOUS MOREL"
(*Morchella crassipes*)



THE CORAL FUNGUS
(*Ciccaria formosa*.)

its star-like covering on the earth, then prepare for rain and cloudy weather; but

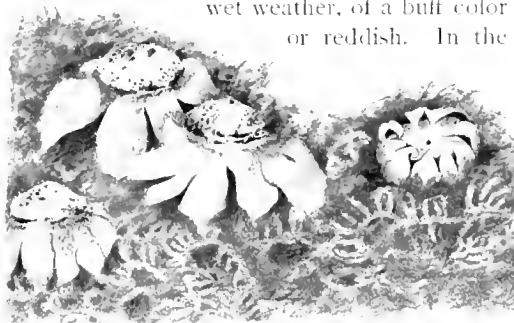

A FAIR-WEATHER TRAVELER.
(*Gaeaster hygrometricus*.)



BIRD'S-NEST FUNGUS.
(*Cyanthes vermicosus*.)

when it closes its petals up around its puffy body, fair, dry weather is at hand. Then it delights in being rolled about by the wind in all directions, scattering its spores as it goes, but always resting at night or in damp weather. A fair-weather traveler, indeed! We often come across that cunning little one, the Bird's-nest Fungus, each nest containing four or five eggs that lack only a fungus bird to sit on them. All have heard the saying, "A mushroom growth"; and, indeed, many of these plants have lives of but a day or so. Others there are which add, year by year, a rim to their cup or bracket; and some have been known to reach the age of eighty years. Our admiration and

HOW SWALLOWS DRINK.

Of course we know that swallows drink as they skim over the surface of water. We have seen how here and there the water ripples on a pond when swallows are gracefully skimming to and fro. One day I sat down beside a small pond where, every evening, many barn-swallows came to bathe and drink on the surface of the glassy water. With sketch-book and pencil in hand, I closely watched the birds; and you may imagine my delight to see just how they managed to touch and dip up the water as they came within a few steps of me. Here is a drawing from the sketch I made. You see,

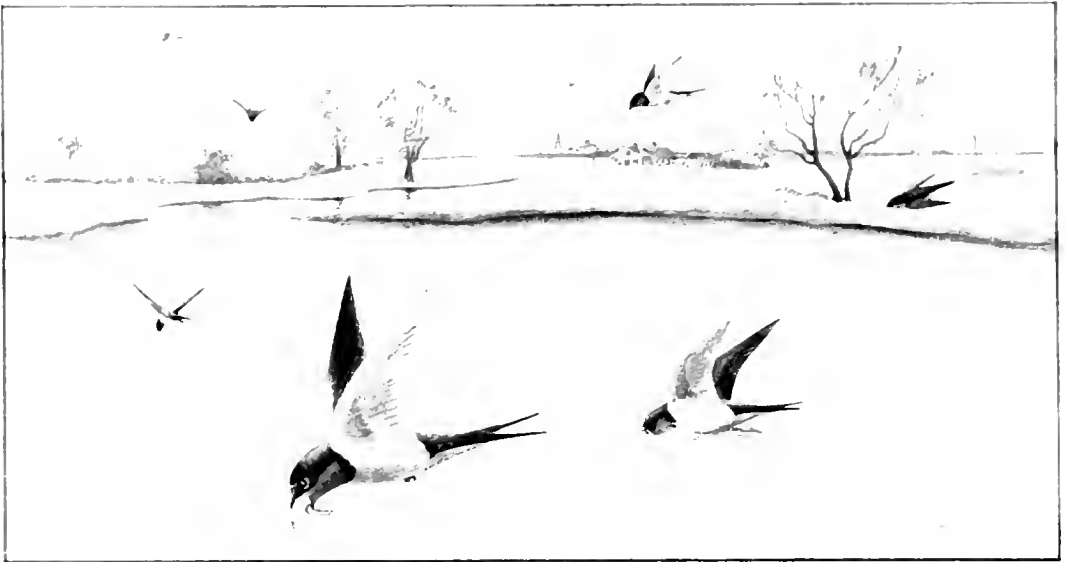

"MANY BARN-SWALLOWS CAME TO BATHE AND DRINK ON THE SURFACE OF THE GLASSY WATER."

interest grow with the study of these little plants. All of us like to know the principal birds, trees, etc., we see on our walks, and why not learn to know the Fungi? In winter as well as summer they await us in woods and fields. We certainly should feel grateful to them when we think how they absorb and purify so much of the poisonous matter in the earth and air, making our world a much healthier place for us to live in; hiding often in the darkest of corners, which they brighten and beautify with their lovely colors. They never cease their good work.

JEAN FERGUSON.

the swallow takes up water in its lower bill, just as you would dip up a little water in a spoon or in the hollow of your hand while you glided over the surface in a boat. Only the under half of the open bill touches the water; if the upper half were also to touch, the water would be forced out on either side instead of being scooped up *into* the bill.

The young swallows, I noticed, were less skilful than their parents, who, of course, had practised this way of refreshing themselves for a year or more. Such things teach us to study nature as closely as possible.

EDMUND J. SAWYER.

DO THEY WALK, TROT, PACE, OR GALLOP?

WHITE STRAWBERRIES.

HERE is a problem for people with sharp eyes! As we all know, a horse when walking or trotting advances only one leg of each pair at a time, but when galloping lifts both fore feet together and then both hind feet. Now the question is how other animals manage this matter. The birds, of course, flap both wings together, but which birds run and which hop? We human beings "trot" when we walk, and "gallop" when we swim—that is, if we are using the plain breast stroke. The dog, however, "trots" for both. Now, do the amphibious animals—the seals, otters, and the rest—swim like men or like other four-footed creatures?

Then there are the fish. One would rather expect that, as they move their tails from side to side, they would flap alternately with the fins, which are their hands and feet. Who can tell whether they do or not, and whether all fish at all times follow one rule? By the way, how does a frog use its "hands"?

The great anatomist, E. Ray Lankester, has lately pointed out that while the "thousand-legs," such as our common gally-worm, advance two feet of a pair together, the centipeds, which are much like them, do exactly the opposite; and the swimming worms also alternate the stroke of each pair of paddles. I doubt if many people can tell on which system the caterpillar manages its dozen or so legs, or whether the adult insect walks, trots, paces, or gallops on its six. How does the spider use eight?

Altogether this is a large field for observation, a field, too, where any one may discover new facts as yet unrecorded, and thus add to the store of knowledge.

E. T. BREWSTER.

WHERE is the boy or girl who does not like to go strawberrying? I know of a place where they are plentiful. Follow the lane where the cows go to pasture and climb the old stone wall that hides an upland daisy-field. Here, where the grass is thin, you will find patches of the luscious fruit. Pick all you want, then string them like beads on a long grass stem and carry them home to eat in bread and milk. When the men come to mow, if you follow the machine you can gather great bunches of the fruit-clusters.

Later there are the wood-strawberries, those shiny pointed berries with their straw-colored seeds scattered over their surfaces instead of being set in deep pockets like the meadow-berries. The hulls always cling to the stem when we gather the fruit, leaving nice little holes in the berries for sugar and cream, if we can find enough to fill a saucer. But the mother partridge has been ahead of us. Almost before the sun was up, she brought her brood along the shady wood road to feast on the luscious fruit.

In my locality among the Berkshires, we have still another kind of wild strawberry, a white one of delicious flavor. Each year, late in June, I visit the queer white garden which produces such odd fruit. It is situated above the brook on a dry, rocky knoll under a tangle of blackberry-brier and sumac. There are

perhaps two dozen plants, and, strange to say, they never seem to increase in numbers. To an ordinary observer they resemble the wood-strawberry plants. However, the flower is more beautiful, the margin of each petal being finely toothed, instead of entire as is the case with field and wood-strawberry blossoms.

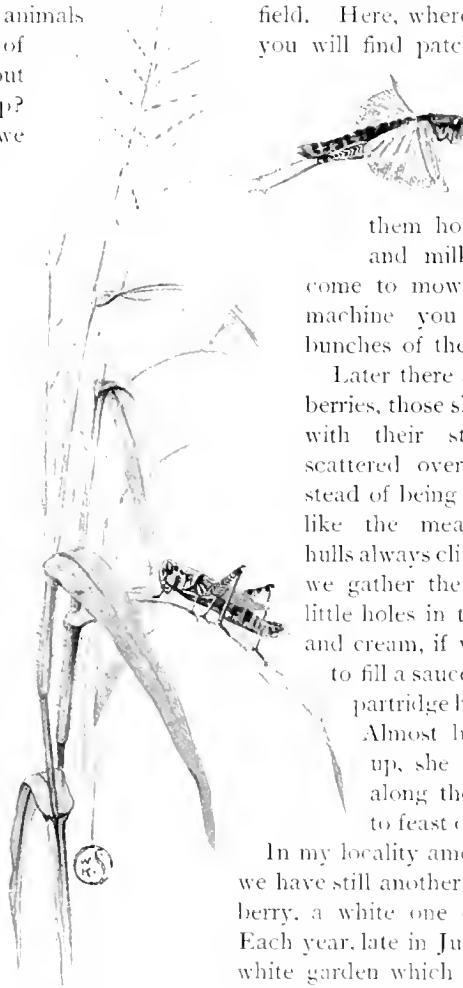

THE GRASSHOPPER GALLOPS (UPPER FIGURE) AND WALKS (LOWER FIGURE).

There is nothing unusual about the fruit until it begins to ripen, when, instead of turning red, it becomes a light straw-color, and



WHITE STRAWBERRIES.

(Photographed from specimens sent by Miss Knowles.)

when fully ripe possesses a delicious flavor, which somewhat resembles that of the pineapple.

I have transplanted a few of these queer plants in a waste corner of the garden where the soil is rich, and they have increased tenfold. Last year the writer enjoyed a tea-saucer of white strawberries.

At first the plants seemed a freak of nature, but later I discovered another patch of the same kind of white berries in an open glade in

the woods half a mile away; and since then a member of the family distinctly recalls having picked white strawberries on the way to the district school over forty years ago. That locality is ten miles distant, as the bee flies, from the other two places, but the soil and spot are similar.

If this is a new species, no other botanist, to my knowledge, except a chance bird, has known of its virtues. Perhaps this is a remnant of some ancient race of strawberry-plants, and in the long struggle for existence the strawberry learned that red fruit would more surely attract the birds and thus scatter its seeds far and wide over the face of the earth!

W. C. KNOWLES.

White strawberries are fairly common in western Pennsylvania and eastern Ohio, but, so far as I can ascertain, the above is the first report of finding the plant as far east as the Berkshires. Botanists propose the name *Fragaria albocarpa* (Britt.) Rydb.

CRUSHING AN INSECT.

HERE is a remarkable photograph from life of an entire chipping-sparrow family in a characteristic occupation. The parent birds are crushing an insect in their bills so that it may be swallowed easily by the young birds. It is quite evident from the photograph that two of the young birds are impatient of the delay in getting the insect crushed.



CHIPPING-SPARROW FAMILY AT BREAKFAST.
(Photograph by C. A. Reed. Copyrighted.)

"BECAUSE WE WANT TO KNOW" St. Nicholas Union Square, New York

WHY SOME WATER HAS AN UNPLEASANT TASTE.

MONTECLAIR, N. J.

DEAR ST. NICHOLAS: I should very much like to know why water that has been in an open bottle in an ice-box that contains vegetables tastes of them.

If the vegetable is at some distance from the water, I don't see how the taste can get into the water. I hope you can tell me.

Yours very truly,

IRVING CAIRNS, JR.

Water seems to be willing to absorb almost any kind of an odor or vapor, especially when the vessel and the vapor are inclosed in a tight box like an ice-chest. Butter has the same peculiarity. I drink water that has been boiled to kill the microbes and any other germs; and, according to my experience, when the open pitcher is kept in the ice-box, I can pretty accurately tell by the taste what else is there, especially if it have a decided odor, like boiled turnips, muskmelons, or boiled cabbage. I know a woman who painted her ice-box, and then stored her week's butter in it. I have been told that a pig will usually eat anything, but no sane or self-respecting pig would have touched that butter. It is said that a pail of water will remove the odor of a freshly painted room, if placed in it with the doors and windows closed. I cannot vouch for the correctness of this, but I know that the water would soon taste almost as much like paint as the paint itself. If the ice-box could be well ventilated by a steady draft of fresh air, the water would not be able to capture so much of the passing odors.

CROCODILES AND ALLIGATORS.

SOMERSWORTH, N. H.

DEAR ST. NICHOLAS: Will you please tell me the

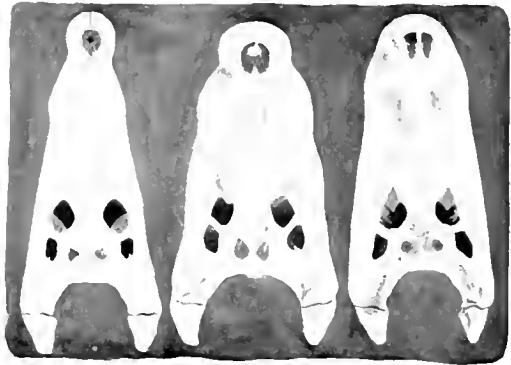

SHOWING DIFFERENCE IN FORMS OF HEAD-BONES.

Florida crocodile.

Indian crocodile.

Mississippi alligator.

difference between a crocodile and an alligator, and their habits?

Yours very respectfully,

PHILIP N. HORNE.

"The difference between a crocodile and an alligator" (a question that has been asked a countless number of times) consists chiefly in the shape of the head, and the manner in which the teeth are placed in the lower jaw. The typical crocodile has a narrow, triangular

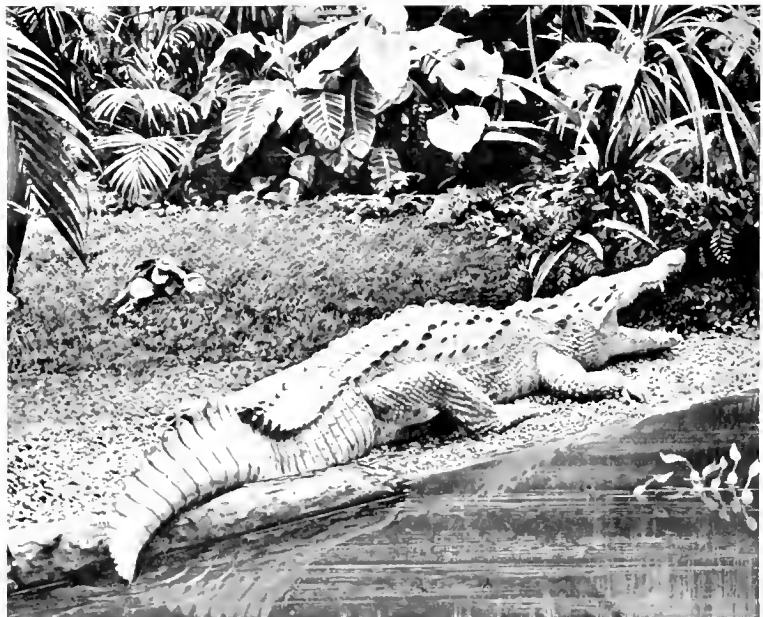

A FLORIDA CROCODILE.

(Copyright, 1904, by W. T. Hornaday.)

head terminating in a rounded point. The head of an alligator is broad, with almost parallel sides, and at the end it is broadly rounded off. The canine tooth in the lower jaw of a crocodile fits on the outside of the upper jaw, in a notch close behind the nostrils; whereas in the alligator the same tooth fits into a pit in

It is probable that your elm-tree has been injured in some way; perhaps a branch has been broken off by the wind and the spores of some fungus growths have gained access at the point injured. The large growth is probably one of the so-called "woody fungi" or "bracket fungi," but which one we could tell



A MISSISSIPPI ALLIGATOR.

(Length 12 feet 5 inches. Copyright, 1904, by W. T. Hornaday.)

the upper jaw, just inside the line of the upper teeth.

WILLIAM T. HORNADAY,
in "The American Natural History."

The accompanying illustrations are from this book, and have been kindly lent by the publishers, Charles Scribner's Sons.

AN ENEMY OF THE ELM-TREE.

TOLLEDO, OHIO.

DEAR ST. NICHOLAS: In our front yard is a beautiful elm-tree forty-five or fifty years old. Last summer a large growth appeared about ten feet from the ground, and the bark is all peeling off the trunk of the tree. Where the bark has peeled are brick-red spots which, under the magnifying-glass, look like clumps of eggs. The wood of the tree seems dead and soft.

Will you please give me an explanation of the growth and the spots? Do you think the tree is dying?

Your interested reader,

KATHARINE MARBLE SHERWOOD (age 13).

only after having seen it. The red, egg-like dots are probably the fruiting stage of another fungus, a *Nectria*. *Nectria* may destroy a living tree and then be called a parasite, or it may develop on dead or dying wood and then be classed as a saprophyte. Your tree may live, even diseased as it is, for a number of years.

CAN INSECTS REALLY SEE?

WEST HAVEN, CONN.

DEAR ST. NICHOLAS: Can you tell me why hornets will not sting you when you are perfectly still?

Yours truly,

LEX NASON.

Hornets and bees are not so apt to sting a person if he keeps absolutely still, but this is not necessarily due to the fact that they do not see readily, but simply that they do not recognize an enemy in a perfectly stationary body. The accumulated intelligence of generations has shown them that still objects, like posts, stones, or trees, are not enemies, and that disturbance of their nests is always occasioned by objects having power of motion. It thus follows that if a hornets' nest be disturbed or if a wild bees' nest be agitated, danger of stinging is much less if the person keeps perfectly still.

But it is best not to depend too much on that, for the hornets may be guided by smell. Professor A. S. Packard says:

It is now supposed that no insects, except dragonflies and perhaps some butterflies, can perceive objects at a greater distance than about six feet.



"A FOURTH-OF-JULY STUDY OF HANDS." BY ROBERT F. JONES, AGE 17. (HONOR MEMBER.)

DAYS OF SUMMER ONCE MORE.

So now we have July again, bringing the season of vacation, with camping, and picnics, and fishing, and all the other good things of summer-time. This is the sixth summer of the League, and a good many of our boys and girls who went camping and picnicking and fishing with us that first summer of our beginning have become big and grown up, and have flown away like birds from the nest. And, like other birds, we think they went rather unwillingly; for there have been many good times and pleasant summers in the League nest; and when the last one comes and it is time to fly, there are some who, exactly like birds, have to be pushed out of the nest to try their wings alone. Happy are they who began with the League very young, at eight or nine, and are still young, with four or five more League summers ahead. There is so much they can do, and they have the best years still before them. Many of them have done much already, and so made a rare beginning of the work which lies be-



"A HEADING FOR JULY." BY STANISLAUS F. McNEILL, AGE 14. (GOLD BADGE.)

THE BROOK.

BY GRACE LESLIE JOHNSTON, AGE 12. (Cash Prize.)

RUSHING down the mountain, tumbling through the vale,
Sprinkling all the land about with spray,
Sliding under boulders which dot the hill and dale,
A little mountain brooklet pushed its way.

It helped to turn the mill-wheel of the mill upon the bank,
It made some pools where children love to be,
It helped the merry fisher as his hook and line he sank,
And it whispered as it ran into the sea:

"I'm glad I helped the miller, and made the children dance,
And I'm glad I made the fisher merry be;
I'm glad I did a bit of work when once I had the chance,
And now I'm glad I've made a larger sea."



"MY ANIMAL FRIEND." BY WARREN ORDWAY, AGE 10. (GOLD BADGE.)

fore. With summer-time and vacation comes opportunity to see and to set down in words and picture, just as we and those who have left us have done during the summers of the past—just as we and those who follow us will do in the summers still to come. We will have, this year, subjects suited to the season; and, with by far the largest membership we have ever known, we will try to make this the happiest and most profitable summer we have ever had.

PRIZE-WINNERS, COMPETITION No. 67.

In making the awards, contributors' ages are considered.

Verse. Cash prize, **Grace Leslie Johnston** (age 12), 174 West End Ave., New York City.

Gold badge, **Stella Benson** (age 13), 39 Norfolk Sq., Hyde Park, London, W., England.

Silver badges, **Dorothy Mercer** (age 13), 180 W.

88th St., New York City; **Margaret P. Talbot** (age 11), Canton Ave., Milton, Mass.; and **Claire Lawall** (age 10), 76 W. South St., Wilkes Barre, Pa.

Prose. Gold badges, **Rebecca Edith Hilles** (age 13), Stanford University, Palo Alto, Cal., and **Margaret Davidson** (age 13), 1510 Third Ave., New Brighton, Pa. Silver badges, **Frances C. Jeffery** (age 13), Tank Home, Oberlin, Ohio, and **Philip Warren Thayer** (age 11), 35 Willbraham Ave., Springfield, Mass.

Drawing. Gold badges, **Stanislaus F. McNeill** (age 14), 605 Jessie St., San Francisco, Cal., and **Helen Mertzano** (age 13), address illegible—please send.

Silver badges, **Hilda Bronson** (age 12), 2310 Arlington Ave., Morgan Park, Ill.; **Enid E. Jones** (age 16), 53 Belgrave Rd., London, S. W., England; and **Priscilla A. Williams** (age 7), 39 Devon Rd., Newton Centre, Mass.

Photography. Gold badges, **Warren Ordway** (age 16), 11 Gibbs St., Newton Centre, Mass., and **Fred Loomis Mohler** (age 11), 127 S. College St., Carlisle, Pa.

Silver badges, **Margaret Andrews** (age 10), 30 Avenue Henri Martin, Paris, France; **Adelia Johnson** (age 12), 620 N. Cascade Ave., Colorado Springs, Colo.; and **Fanny J. Walton** (age 15), Langhorne, Pa.

Wild Animal and Bird Photography. First prize, "Squirrel," by **Margaret A. Dole** (age 14), 91 Glen Rd., Jamaica Plain, Mass. Second prize, "Wild Ducks," by **Claire Curran** (age 15), Hotel Touraine, Brooklyn, N. Y. No third award.

Puzzle-making. Gold badges, **Clara Beth Haven** (age 15), 102 Main St., Watertown, N. Y., and **Angus Bandel** (age 17), 1123 Bolton St., Baltimore, Md.

Silver badges, **William Shipman Maulshy** (age 14), 80 Curtis St., W. Somerville, Mass., and **David Fishel** (age 13), 34 East 76th St., N. Y. City.

Puzzle-answers. Gold badges, **Bessie Garrison** (age 15), care of H. Perkins, Nacogdoches, Tex., and **Emma D. Miller** (age 14), 1952 N. Broad St., Philadelphia, Pa.

Silver badges, **Florence G. Mackey** (age 12), 1204 Columbus Ave., Sandusky, Ohio, and **Louis Stix Weiss** (age 11), Depot Lane, Ft. Washington, N. Y. City.

THE BROOK.

BY SILLIA BENSON (AGE 13).

(Gold Badge.)

THE little brook went winding down the hill,
 Ran rippling down the hill,
 The frowning, gloomy hill,
 When all the world was dark and gray and still,
 Preparing for the tempest that was nigh;
 But still the brook went rippling, dancing by,
 Laughing, all heedless of the stormy sky.

Unceasing ran the brook—a silver thread,
 A narrow, winding thread,
 A dancing, shining thread,
 A little spark of life amongst the dead;
 And when the sunbeams drove away the rain,
 Still happier was the brooklet's merry strain
 Because the world was gay and bright again.

A RUNAWAY ADVENTURE.

BY REBECCA EDITH HILLES (AGE 13).

(Gold Badge.)

IT was one of those rare summer mornings that come only to San Diego. The air, in all its salty freshness, blew straight in from the sea, beyond beautiful "Point Loma," which sloped like a bit of fairyland beneath the morning sky. The horses, their heads high, came prancing to the door, and off we started on the forty-mile drive to queer old La Juana, Mexico.

For weeks we had been waiting until trail little Miss Cranston, the missionary, could go with us. So, great was our joy when we descended to the carriage and found her waiting, her face one beaming smile beneath her little black bonnet. Off we started, Miss Cranston



"MY ANIMAL FRIENDS," BY FRED LOOMIS MOHLER, AGE 11. (GOLD BADGE.)

saying over and over: "This is a great day for me! My first holiday in so many, many months!"

How little any of us knew what a great day it was, indeed, to be before we ever again saw our vine-covered hotel set among its palms and roses! I sat on the front seat, beside our driver, a pious-looking old Quaker with long white hair and whiskers. He was the owner of the big bay horses, and quite as proud of them as they seemed to be of themselves. My mother noticed, however, that one of them shied at every passing carriage; but the driver assured us he'd "raised 'em both, an' they were just as gentle as kittens."

He might have added that one was only a colt, and frightened easily, but he left us to find that out a few hours later.

After a glorious day, we found ourselves "homeward bound." I, sleepy and tired, tucked my head in mother's lap, and soon went to dreamland. A voice like Miss Cranston's wildly shrieking, "Whoa!" wakened me, while I felt the carriage lifted high in the air as the horses sprang to and fro. All the sins I had ever done came up before me like a black cloud, and, wringing my hands, I wept bitterly. In a terror-stricken voice I heard myself saying, "O Lord, have mercy!"

Bits of harness flew in the air, and pieces of the carriage broke off! We saw the driver would be dragged over the dashboard to his death, did he continue to



"MY ANIMAL FRIENDS," BY MARGARET ANDREWS, AGE 10 (SILVER BADGE.)

cling to the reins, as the horses had broken everything that held them to the carriage; and we all cried, "You'll be killed! Throw away the reins and let them run!"

That saved our lives, for they ran on, and we tumbled out of the wreck, within a few feet of a telegraph-pole close by a railroad track, where another moment would have sent us to certain death.

THE COURSE OF THE BROOK.

BY DOROTHY MERCER (AGE 13).

(Silver Badge.)

NEAR the cloud-encircled summit

Of a mountain crowned with snow

Is my source, from which I trickle
To the valley far below,

Where I babble through a pasture,
Daisies grow along my brink,
And I widen here, and deepen,
Where the cattle come to drink;

Then I join a mighty river,
And we two rush on in glee,
Past the dusty, murky cities,
Till we reach the open sea.

AN ADVENTURE ON THE WAY TO JAMAICA.

BY MARGARET DAVIDSON

(AGE 13).

(Gold Badge.)

We started from Philadelphia, the 1st of February, for Jamaica. It is a five days' voyage.

The second night we were out we encountered a storm. The electric lights went out, the engine broke down, and it was three hours before it was sufficiently repaired to move on.

In the meantime the ship was at the mercy of the waves, which dashed all over the deck, higher than the top of the state-room doors. The ship would roll over and go down, down, till the port-holes touched the water. Then it would slowly right itself, and go down as far on the other side. The sensation was fearful. When the boat would go down, we would think it would never right itself again.

The howling and screeching of the wind, and the moaning of the waves, made the night terrible.

it open. There we were—my mother in the lower berth, and myself in the upper—in total darkness. If one of us did not pull the door shut, we should be washed out and drowned. Just as the boat started to right itself, mother jumped out of her berth and tried to pull the door shut. In her agony pulling against the wind, the knob came off in her hand, and for a moment it seemed as if we should both be drowned. Just then a fierce gust of wind blew the door shut and knocked her in on to the floor of the state-room, and we were safe.

THE BROOK AT OUR FARM.

BY CLAIRE LAWALL (AGE 10).

(Silver Badge.)

The brook at our farm is different
From any I have seen,
It runs along the meadow,
And by the grass so green.

I love to take my playthings there,
And play the livelong day,
While "Bobby," my little terrier,
Scampers among the hay.

I think I see the fairies there,
When I am by myself;
They sail in little fairy boats,
And the boatman is an elf.

I want to go and play with them;
But when I start to rise,
And just begin to speak to them,
They vanish from my eyes.

There is nothing I like better
Than to dream beside the
brook,
About the fairies I have seen.
That vanish when I look.

Oh, the brook at our farm is different
From any I have seen;
It runs along the meadow,
And by the grass so green.



"MY ANIMAL FRIENDS," BY ADELIA JOHNSON, AGE 12. (SILVER BADGE.)

NOTICE.

The St. Nicholas League is an association of ST. NICHOLAS readers. Any reader of the magazine (not necessarily a subscriber) is entitled to membership, and will be sent a League badge and instruction leaflet, free, on application.

AN ADVENTURE IN THE HILLS OF INDIA.

BY FRANCES C. JEFFERY
(AGE 13).*(Silver Badge.)*

DURING the hot season in In Jia, which comes about the month of May and lasts through August, most of the missionaries and their families go up to the Pulney Hills, where it is cooler.

It was during a season at Kodai kanal that I had an interesting adventure.

One bright afternoon my brother Richard, sister Pauline, friend Willie, and myself went out in the woods for a picnic. We picked the wild violets and ferns and talked and told stories.

When we came to a comfortable-looking log my brother said, "Let's sit down here and eat our plantains and sandwiches"; and



"LOCKED-OUT" BY ORIAN L. DYER, AGE 14.

We accepted Pauline's suggestion, but Willie's thought was not taken so agreeably. Just then we heard voices, and all of us crouched behind trees. Two Tamil boys walked past us with bows and arrows, probably intending to shoot birds.

When they had passed we went on up to a little stream and began wading. We were splashing about gleefully, when I noticed my small brother was standing still, intently looking at something. I followed the direction of his gaze and saw a chetah.

He looked almost as large as a tiger, and generally devoured only dumb animals.

But this fact I did not know.

"It's a tiger!" I gasped; and, seeing that Willie and Pauline had taken to their heels, I clutched hold of Richard's arm and followed. We did not stop till we reached home.

A few days later a chetah was killed in the same woods, and I excitedly declared, when I saw its body, that he was the same one.

"SQUIRREL" BY MARGARET A. DOLE, AGE 14
(FIRST PRIZE, "WILD-ANIMAL PHOTOGRAPH.")

as we were hungry we followed his advice.

"Let's pretend men were hunting for us," cried Pauline.

"And that they cooked us," added Willie.

WHAT BECAME OF THE CREAM-PITCHER.

MOSES grew to be a fine big cat, and we were very fond of him; but, I am sorry to say, he could not be taught to be honest and trustworthy. When we were in the room he would keep off the table and would not eat the food that belonged to the family; but when we

were out of sight he was liable to do anything. One day my mother could not find the cream-pitcher, which she had placed, half full of cream, before the pantry window. Moses slept in a basket behind the stove; but that night he failed to appear, though called and looked for everywhere. For five days he was absent. One morning my mother was washing dishes, when through the open kitchen door walked an emaciated and despon-

"WILD DUCKS" BY CLARE CURRAN, AGE 15
(SECOND PRIZE, "WILD-BIRD PHOTOGRAPH.")

dent gray and white cat, with the rim of the missing cream-pitcher around his neck! It was Moses. Where he spent those five days, and what were the harrowing details of this second adventure, we never knew; but he never again took anything that did not belong to him.



"ANIMAL FRIENDS," BY DUDLEY WALLACE, AGE 14

THE ADVENTURES OF MOSES.

BY PHILIP WARRIN THAYER
(AGE 14).*(Silver Badge.)*

HOW HE ARRIVED.

IT was in March that I first saw him. The winter snows were melting, and the brook behind the house was transformed into a foaming yellow torrent. I had been building a castle, but had stopped for lack of boards; so now I stood on the bank of the stream with a long pole, trying to bring to land any suitable pieces of wood that might be floating by. I had already secured quite a few choice pieces, when along came an empty orange-crate with a thoroughly drenched gray-and-white kitten perched on top of it. By leaning far out I managed to bring it ashore, and the shivering kitten seemed to be very glad to be through with his first adventure. I took him home, dried, fed, and warmed him, and of course we called him "Moses."

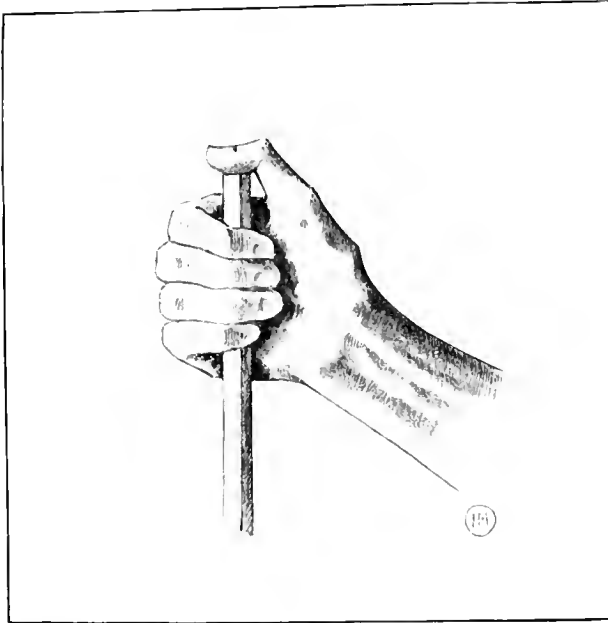

"A STUDY OF THE HAND" BY HELEN MERTZANOFF, AGE 13. (GOLD BADGE.)

THE BROOK AND ITS FRIEND.

BY MARGARET P. TALBOT (AGE 11).

(Silver Badge.)

COME, little brook, I'll run with thee;
 We'll run away to the deep blue sea.
 "Oh, little friend, I would—but how?
 I'm frozen to ice, and can't come now."
 Well, then we can wait till the summer or spring;
 Then onward we'll go and merrily sing.

HOW THE ROBIN GOT A RED BREAST.

BY JOHN GUY GILPATRICK (AGE 9).

ONE day the robin thought he would be swell, so he bought a black coat and white vest and a red tie.

He was going to a dance, so he put on his best clothes and the red necktie. It was in April, and raining hard, but the robin went. He forgot his umbrella, and when he got to the dance he looked down at his white vest, and there—the tie had run all over it!

The robin scrubbed and scrubbed, but the red would n't come off; so from that day robins have had red breasts.

THE BROOK.

BY SUSAN WARREN WILBUR (AGE 12).

GLIDING 'neath o'erhanging rushes,
 Bubbling o'er a pebble round,
 Whirling past a stone and flowing
 Into spots no man has found;

Peering into fishes' dwellings,
 Hiding 'neath the grasses long,
 Flowing, flowing ever onward
 Goes the brook with murmur'ing song.

THE SONG OF THE BROOK.

BY GERTRUDE A. STRICKLER (AGE 15).

I STARTED—oh! so long ago,
 No one remembers when!
 And I've been singing, as I flow,
 For every day since then.

For every day? Oh, no, I'm wrong;
 Sometimes quite still I keep,
 And do not sing my little song—
 For I am sound asleep.

But when the days are long and hot,
 I sing, and sing, and sing;
 While in some cool and shady spot
 The cows lie listening.

And out and in, and in and out,
 From shadow into light,
 The little fishes dart about
 And chase the sunbeams bright.

And though to watch the fishes play
 I'd like to stop awhile,
 I haste along my winding way
 O'er many a pleasant mile.

AN ADVENTURE.

BY JOSIE HAMPTON (AGE 12).

ONE February morning, about six o'clock, a party of friends and myself started out with our skates slung over our shoulders, thinking that we would get a good skate before the ice began to get slushy. When we arrived we buckled on our skates in a great hurry; but when we began to skate we found, to our dismay, that it was rough—so we started to a much deeper pond not far off. Several reached the pond before the crowd came, I being one of these. The ice was very good in the center, but near the edges it was thin; but we were not afraid, and began to enjoy ourselves. Suddenly one of the boys who was skating quite fast ran into a crust of snow on the ice and broke through. One of the girls and I, being the nearest to him, attempted to be the gallant rescuers, and the ice broke with us also; so there we were all three in the water, holding to the edges of the ice and trying to climb out; but, of course, the ice would break just as we were about out, and so we got very discouraged and gave up the attempt. Then



"MY ANIMAL FRIEND." BY MARJORIE E. FARMS, AGE 14

Frances began to call for help, and the whole crowd came running as fast as they could—some with one skate on and one off.

We were pulled out dripping and wet up to our necks (for we had managed to keep from going under). After they got me out, as I started to walk I broke through again, but was pulled out in a hurry.

We looked like a funeral procession instead of the gay party that had started out two hours before.

When we arrived at our homes our teeth were chattering so fast that we could hardly speak; but we were all out playing that afternoon, as if nothing had happened; and a crowd of us went back and gathered up a few skates that had been left.

I told ma-ma that the medicine she gave me was *almost* as bad as falling in.

THE SONG OF THE BROOK.

BY CLEMENT K. WOOD (AGE 16).

I RISE in a pool that is limpid and cool,
Where the water springs up with a will;
Through the woodland I flow, with its trees
bending low;
Then ho! for a run down the hill.

Though I'd rather stay here, I must follow, I fear,
Where the flowers are dried by the sun;
For I'll do them more good than I could in this
wood;
So downward—far downward—I run.

And the thirst-smitten cows, here beneath the tree
boughs,
Come gladly my waters to drink,
Where the sweet flowers grow as I steadily flow
And broider my ferny-fringed brink.

On, on down the hill, and I turn every mill,
For I've grown to a creek in my flight.
As onward I flow to a river I grow—
Hurrah! for the ocean 's in sight!

But I'm caught up again to descend in the rain,
And down on the mountains I spill.
Now ho! for the pool that is limpid and cool,
And again for a run down the bill.

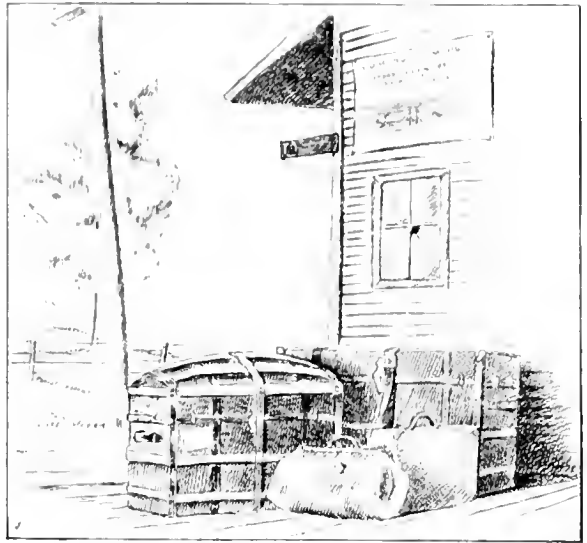

"JULY," BY OSCAR L. SCHMIDT, AGE 13.

A WESTERN HOLD UP.

BY LUCILE RAVENSCROFT (AGE 13).

PERHAPS you have heard of the numerous hold-ups in the West. I live in Denver, and will tell you a true story of a hold-up—the only one I was ever in. It happened when I was about eight years old. Two of my friends and myself had been planning for several days how to get some money to buy candy with. We earned a little, and were given a little, and at last had the required amount—which consisted of fifteen cents each. It was a bright spring day, and we went hippety-hop, with our arms around each other, to the nearest store to spend our money. This meant a great deal to us.

We took some time in choosing the different kinds we wanted, and were happily coming home when, all at once, we saw four unknown boys barricading the sidewalk.

They told us we could not pass unless we would give up all our precious candy.

We were so frightened we did as they told us, and ran home as fast as we could go—three very unhappy little girls.

FOLLY MILL BROOK.

BY LEWIS S. COMBES (AGE 8).

(Honor Member.)

TRICKLE, trickle, little brook,
Coming down the hill;
Trickle, trickle all the way
Down to Folly Mill.

Ripple, ripple through the bridge,
Into meadows wide;
Ripple, ripple o'er the stones
Where the fishes hide.

Hurry, hurry to the pond
By the maple-tree;
Slower, slower through the marsh,
Flowing to the sea.



"MY ANIMAL FRIEND," BY SIDNEY MOISE, AGE 17. (HONOR MEMBER.)



"A HEADING FOR JULY" BY MAUDE G. BARTON,
AGE 14

AN ADVENTURE.

BY IRENE BOWEN (AGE 13)

THE hero of this tale was a very humble one. He was only a yellow puppy with a wrinkled black nose, curling tail, and short legs. He was a common dog, and, as his mother soon died, he was alone and friendless. He had a home, but it was a very poor one, for his masters were of that class which travel in wagons as gypsies do.

"Captain" he was named, but "Cap" he was called whenever he was called anything. Cap had a kind disposition which rarely protested against the kicks he received. Sometimes, however, he stole food when he was very hungry, and then he was beaten unmercifully.

At last Cap decided to go away, but he found the world no kinder. Boys tied cans on his tail, cats fought him, and dogs chased him. Finally a cow tossed him upon her horns and threw him over a fence.

When Cap could walk again he went home—for the wagon was still home. When he reached the place where it had stood it was gone, and Cap trotted many miles before he caught it. Then he sank down to rest, but the men soon saw him and were angry. They had only kept him to watch the wagon; and since he did not do that, they did not want him.

That night the men visited a large farmhouse, and there found a place in which to fasten Cap.

Two old ladies lived in this house, and their little niece, Ethel, was visiting them. In the morning one of them opened the wood-house door, and a yellow dog jumped upon her, barking joyfully at his release.

For a week Cap was happy; Ethel petted him, and he grew strong and playful. But our hero had one more obstacle in his path. The assessor came. Cap's story was told; the assessor proposed to chloroform him, and they assented.

Ethel was horrified at the thought of killing the dog, and took him and ran away to her swing. There her aunts found her crying, with her arms around Cap;

and her tears must have changed their intentions, for the assessor went away satisfied.

Cap had entered his kingdom. He lived there many years; and one day, when he was old and blind, Ethel came to see him. He greeted her joyfully and then fell down at her feet, dead.

THE LEGEND OF THE WILLOW-TREE AND BROOK.

BY FRANCES LUBBE ROSS (AGE 14).

A WILLOW-TREE, one lovely day,
Espied a brook, so legends say.
So laughing, gay, and fair was she,
That she bewitched the willow-tree.
He bent far down to whisper to her;
He spoke sweet words and tried to woo
her;

But brooklet, pretty, saucy maid,
To him no kind attention paid.
She sparkled on beneath the rays
Of sun-shine bright; for days and days
He begged her, weeping, to be kind,
But to him she was deaf and blind.
And so he 's stayed, for many years,
Until, because of all his tears,
A weeping willow he 's been named;
While brooklet, for her coldness famed,
Still sparkles on, most full of glee,
Not noticing, although the tree
Beside her, weeping, still is found,
With branches hanging to the ground.

THE ADVENTURES OF A RUBBER DOLL.

BY FLORENCE R. T. SMITH (AGE 16).

"PUDGE" was my first doll, and he is now over fifteen years old. As he always went everywhere with me,—to bed and the bath-tub among other places,—his rubber face is so cracked that if one attempted to put it in shape it would surely break, as it is brittle.

When I was about five years old, Pudge and I went on a picnic near a lake about five miles from home.

After lunch I went out in a boat with a lady of the party, and, after fastening a string to the doll's neck, I pulled him through the water behind me.

Of course the string broke, and Pudge floated away.

Before I noticed his absence he had vanished completely. I felt very badly, so we went out on the lake later, and at last found him bobbing about among the lily-pads.

His next journey was a trip to Newark, New Jersey, a year later. As Pudge had no suitable hat for the occasion, I had him borrow one of his brother "Tommy."

When my mother and I left the train at Newark we were jostled against other people in the crowd, and the hat was lost. Looking around, I saw it caught in the fringe of a lady's cape, and I screamed, "Oh, mama,

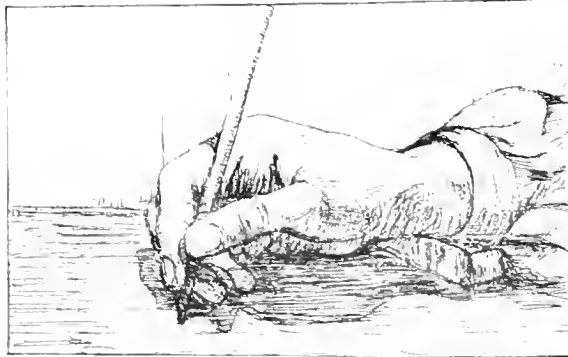

"STUDY OF A HAND." BY ENID E. JONES, AGE 10. (SILVER BADGE.)

Pudge has lost Tommy's hat, and now Tommy won't have any, either!"

By the time I had told my mother where the hat was, the lady was out of sight, and Pudge never found the borrowed hat. Poor old Pudge is now packed in a drawer with his brothers and sisters, too old to be of use to any one.

Several years ago his queer, cracked face won for him, at a doll show, the prize awarded to the homeliest doll.

I think I had better times with Pudge than with any of my other dolls, although he was certainly the "ugly duckling."

A FAIRY TALE.

BY MARGUERITE HUNT (AGE 13.)

MAID MARION was a pretty child,

A pretty child was she,

Who dearly loved the fairy folk

With a fondness fair to see.

And all the bright, warm summer days

She hunted high and low

For pixies, gnomes, and fairies sweet,

That she so wished to know.

And one day, as she wandered—

Wandered o'er the meadows green,

A fairy came and stole her,

And she never more was seen.

Her lifelong wish was granted,

She was happy as could be;

She was living with the fairy folk,

A tay herself and—free!

THE DIARY OF A DRAGON.

BY MORRIS G. BISHOP (AGE 11).

(Honor Member.)

12680 B.C.

JUNE 1. Ate a magician.
I think I'm getting sick.
That magician had a bottle labeled "Sleeping Mixture." I think I'll take it. My old friends the Seven Sleepers said there was nothing as refreshing as a good long nap.

1905 A.D.

June 1. I took it. I didn't remember anything else until I found an old man prodding me in the ribs and saying: "Fine specimen of a *Kinlobistoxatsthorus*." I ate him instantly for insulting me so. What does he take me for? A Russian?

June 7. These people have more impudence. I met a man to-day who tried to sell me a sewing-machine. I threatened to eat him, and he offered me a cure for indigestion. I ate his traps besides himself.

June 8. Went to a museum, and there I saw the bones of my poor old mother, labeled "*Shakepopolaristank-oranorifitorus*." I just lay down and cried. But I only cried the oil for that sewing-machine. It's my



"A HEADING FOR JULY." BY HELEN O. C. BROWN, AGE 15.

own fault. The family doctor always said such things would go to my head.

June 12. Saw a lot of people getting something from a boy called a newsboy. I went up to him. He said, "Take the 'World'?" "It would be too much at one gulp," I replied. "'Sun'?" said he. "No, thanks; I don't deal in planets," said I. "Have a 'Herald'?" he said. "Yes," I answered. "Heralds have a distinct flavor and don't wear armor, which gives me indigestion." But the insolent cub only gave me a piece of paper. He tasted awfully.

June 17. A dime-museum man offered me \$20 per week and all his creditors for food if I would join his company. I accepted.

June 18. The dime-museum man was saying, "This is the only great and original dragon," when a man said, "Aw, he's all hot air." That dragon is just two men inside a skin." I showed him I was all hot air. I scorched the people for ten rows back. And as for two men, there must have been a dozen.

(Extract from the "New York Courier.")



"ANIMAL FRIENDS." BY LANSY J. WALTON, AGE 15

"A dragon was found sleeping on the third rail of the subway, just above Forty-second Street. He stopped traffic for four hours, until he was blown up with dynamite. That cleared the track."

THE BROOK FAIRY.

BY ROBERT F. ROGLES

(AGE 10).

BENEATH the wind-blown sedge, where April flowers scatter pink petals in the hurrying stream, There is a cool blue grotto, dim with vines,

Where sits a water-nymph with harp of pearl,
Attuned to faint and fairy melody.
Perchance on rushy banks, by shady elms,
She rests, and binds her misty golden hair
With water-lilies dropping silver dew,—
Her sun-kissed hair, which pours about her face,
Over her lovely bosom and white arms,
And mingles with her jewel-tissued weed,
Broided with many a wondrous sea-carved gem,
Woven of shimmering green, a misty gauze,

Through which, as seen through waters, half revealed,
 Shines her sweet body, rosy in the light.
 And through the trees the weary wanderer,
 Lured by the wave-like music of her song
 And by the winsome magic of her eyes,
 Kneels at her feet, and in her soft, sweet arms
 Drowsily wastes his soul in kisses; then
 She slowly bears him down in ripples cool,
 To sleep forever in her dim, blue cave;
 While bending o'er him in her loveliness,
 The maiden softly sings his slumber-song.

AN ADVENTURE.

BY DONALD M. BROWN (AGE 11).

ONE bright Saturday morning in the summer of 1902, I, in company with about seventy other boys, all members of the "Boys' Club of Chautauqua," started for a hay-ride, taking a lunch of lemons and candy; intending to stop at Wanita Point, a summer resort some two miles west of the assembly grounds, where the larger boys were going to have a lemon fight in the water.

Here, out from a large hotel, a long dock extended, its end standing in about ten feet of water. Upon this the boys gathered to wave a salute to the head instructor as he came up the lake in a launch, accompanied by his wife, who was just returning from a trip she had taken in search of health.

We saluted, and the launch was within six feet of the dock when the latter gave way, leaving about fifty small boys—few of whom could swim—struggling in the water. Things seemed pretty serious for a while.

One boy, evidently pretty much surprised at this sudden ducking, struck for the middle of the lake, crying that he could not swim a stroke!

I sank once, but when I came up I saw a pole projecting up out of the water, and, seizing it, held myself up until one of the instructors lifted me on to the remaining part of the dock, and I went inshore.

And so we were lifted, one by one, from our watery bed by the instructors and older boys, who worked bravely. The strict discipline we had been under, the obedience to the instructors which we had been taught, really prevented a serious accident.

As it was, the only real loss we suffered was in hats instead of life, the storekeeper finding it very hard to supply fifty new hats for Sunday.

WHERE DO THE FAIRIES MEET?

BY JESSICA NELSON NORTH (AGE 13).

(Honor Member.)

WHERE, oh where, do the fairies meet?
 I've hunted the country through;
 I've looked in the heart of the violet-sweet
 As it shone with its wealth of dew,
 And I've watched the crest of a cloudland fleet
 As it floated across the blue.

I've searched the sky when the thunder rolled,
 By the wrestling demons riven;

And I've watched the lights of red and gold
 As they shone in the west at even,
 And the still white beams, so clear and cold,
 That fell from the moon in heaven.

I thought, as I stood on the silent hill,
 That I heard their hastening feet;
 But it was the wind of midnight chill
 As it rustled the fields of wheat.
 And the question remains unanswered still,—
 Where do the fairies meet?

MY BROTHER'S ADVENTURE.

(A True Story.)

BY ALICE BRAUNICH (AGE 17).

IT was in the summer of the year 1902, and in the city of Amsterdam, that my little brother met with an adventure which, though it now seems to him more amusing than thrilling, made him wish, at the time, to leave the land of canals forever.

We had spent the afternoon at the Zoological Garden, with its large collection of birds and beasts; had with difficulty torn ourselves from the bright flamingos and graceful swans; and were returning on foot to our hotel. In that part of the city the walks are quite narrow—so narrow, in fact, that we were obliged to march in single file. Hugo, the little brother, led the way; I followed; then came mama, next papa, and the big brother brought up the rear. We were walking along a canal, and, as canals were still quite new to me, I went slowly, enjoying the view, and not noticing that my little brother was at a considerable distance ahead.

He was walking on, unconcerned, in haste to reach the hotel for supper, when he was met by a group of Dutch boys about his age, who stopped him and began to talk to him in Dutch. Hugo, bewildered, cried, "*Kannt verstan!*" and tried to move on. But one of the boys held him fast; another seized his cap—an English cap; and they all continued to talk in loud and angry tones. The only words that my brother could understand were "Englishman!" and "Canal!" which they repeated frequently and with great vehemence.

Hugo turned pale, for he knew that the Dutch were unfriendly to the English on account of the Boer War; and he thought that the boys were threatening to throw him into the canal. They were four against one.

Fortunately the rest of us arrived upon the scene before the Hollanders could put their threat into execution. At sight of us the boys fled, without giving papa a chance to explain that Hugo was not an Englishman, but an American.

We found the British cap upon the ground, where one of the boys had dropped it; but my brother never wore it again as long as we stayed in Holland.

LEAGUE NOTES AND LETTERS.

MARGARET E. BULL, Secretary of Chapter No. 759, of Naugatuck, Conn., writes to say that this chapter gave a very successful entertainment, which consisted of a ST. NICHOLAS play, "The



"MY ANIMAL FRIEND," BY JOHN S. BERRY,
 AGE 17 (HONOR MEMBER)

Magic Sword," on Washington's Birthday. Cake and ice-cream were served, and the total receipts were \$130.37, of which the profit, \$20, was given to the King's Daughters for charitable work. This is very commendable work, and we are only sorry that Chapter No. 750 was not competing in one of our Chapter Entertainment Competitions, as it would almost certainly have won a prize. Never mind, there will be other competitions by and by.

Chapter No. 788, 37 Stimson Place, Detroit, Mich. (Grace L. Barber, Secretary), would like to correspond with foreign chapters. Will foreign secretaries please consider this proposition?

Maria Bullitt would like to know if drawings can be made with a brush. Yes, if made in black and white only. Maria also asks, "What is an honor member?" An honor member, as often explained, is one who has won a gold badge.

The following League members would like to exchange souvenir postal cards: Dorothy Mercer, 80 W. 88th St., N. Y. City. Fileen Keefe, 16 Richmond St.; Geraldine Carleton, 229 City Road; and Beatrice Carleton, 229 City Road, all of St. John, New Brunswick. Margaret Bates, 100 Riverside Drive, N. Y. City. Florence Short, 307 Fourth Ave., Asbury Park, N. J.

TYNEMOUTH, ENGLAND.

DEAR ST. NICHOLAS: I received your badges last Monday, and felt exceedingly important at getting such an immense envelop. The badges are, we all think, very pretty, and we always wear them. We had a meeting last Thursday. I read the rules out and made some announcements, and then it was time to stop. It was my birthday yesterday. I was fifteen. I got some lovely presents.

My sister is going to be married on the 4th of April, and I am going to be chief bridesmaid; it is getting very exciting—what with having dresses fitted on, and presents arriving, etc.

Now I have no more to say.

Yours truly,

MURIEL FAIRWEATHER.

SWANMORE SPRING, KANS.

DEAR ST. NICHOLAS: I thank you very much indeed for my gold badge. I tried to win it for so long; and now that I have, I don't know how to express my thanks.

When the magazine came I looked in the Roll of Honor, and not finding my name there, did not suppose that it deserved encouragement. But as it is almost impossible to lay the ST. NICHOLAS down before one has looked it through, I began to explore the pages of the League and saw it.

I knew very little about poetry until I joined the League, and then I always compared my contributions with the best, corrected my mistakes, and never made them again.

I don't think we could do without the ST. NICHOLAS, for we have taken it since 1899.

Wishing you many prosperous years, I am your interested reader,

GLADYS NELSON.

MILL VALLEY, MARIN CO., CAL.

DEAR ST. NICHOLAS LEAGUE: I live in a little town just outside of San Francisco, at the foot of Mount Tamalpais. Together with several friends, I cross the bay to San Francisco to high school. I have a camera and will exchange pictures of our home and surroundings with a girl correspondent of fifteen or sixteen, if she wishes to.

Hoping you will always prosper and bring as much joy to those who will take you in the years to come as you do to those now,

I remain,

ELIZABETH BRIDGE.

P. S. I want to add that I belong to the League Chapter No. 651, in which I have had many jolly times.

GLEN LOCH, PA.

DEAR ST. NICHOLAS: There is a flicker (or pigeon-woodpecker) that comes to our roof at about six o'clock in the morning and pecks a few times, then drums; and it makes the funniest noise, because the bird is on top of the attic. It sounds like this: "Bri-rr-rum-bum-bri-rr-rum-bum." The first day we heard it we thought it was somebody knocking on the door, and so everybody (that is to say, mother and my tutor, Mr. Beede) went bustling around the house; and the next morning mother looked out of the window and saw a woodpecker sitting on the peak of the roof, pecking away at it. The reason that it does this is because the worms come out to see what the matter is, and the woodpecker calmly gobbles them up; and he does this until he gets almost all the worms out of the roof.

In Athens my father saw a little girl with a St. Nicholas badge on, and my father asked her what it meant, and she said: "Whv, did n't you know I belonged to the St. Nicholas League, and that this is my badge?" She seemed to be very proud of the badge.



"A READING FOR JULY." BY HILDA ERONSON, AGE 12. (SILVER BADGE.)

because we almost never saw her without it on. We have four hundred (400) pigeons,— Antwerp homing pigeons I mean,— and six (6) or seven (7) little calves, and they butt (or try to butt) everybody that passes by them; even their mothers fall a victim to their butting.

We had a thoroughbred Jersey heifer named "Beauty," and how do you think it died? By eating white lead for its breakfast. I think it thought the lead was condensed milk.

I remain your friend,

HOWARD AVH WORRELL KATES (age 11).

BROOKLYN, N. Y.

DEAR ST. NICHOLAS: Thank you for the St. Nicholas badge and leaflet. I want to tell you something that our collie dog did. One day Clara, our maid, went out rowing in the evening, and Lady Babbie followed her down to the dock. Then Clara put a box of matches in the bushes, so she could get them when she came back, and off she went; and when Clara got home at eleven o'clock at night, she saw Babbie waiting on the dock. As Clara stepped off she heard something rattle in Babbie's mouth. She called her to see what it was. As she took it out she saw that it was the box of matches, and it had not a scar on it. I think Babbie must have known it was something that Clara had wanted.

Your affectionate reader,

ALICE BRISTOW (age 9)

SHEPHERDS BUSH, LONDON, W., ENGLAND.

DEAR ST. NICHOLAS: I have to thank you very much indeed for awarding me a silver badge, as the result of a photograph that I sent in.

When dear old St. Nick arrived, I turned over the pages until I came to the Roll of Honor. After glancing anxiously down the columns and not seeing my name, I returned the leaves with trembling fingers, and saw my photograph placed second in the League, with "silver badge" underneath.

I think I was simply crazy for a little while, and no words can fully express how pleased I was, or how grateful I am to you.

There is only one thing I am waiting for now, and that is the badge itself. I eagerly watch every post, and am quite disappointed when it does not come.

I must, I suppose, be patient; and I hope by the time you receive this I shall be wearing it. I thank you for it in advance, and just know it will be perfectly splendid.

I am eager to win more laurels if I can, especially as I have only six months left to do so. I have worked up from the Roll of Honor, and hope to end with a cash prize. I am afraid I am not very modest.

I take many English magazines, but without doubt there are none to compare with St. Nick.

I have one American friend, but she is in Germany. I should like very much to correspond with some of your League members, as I am an ardent collector of post-cards, and should dearly like some of America.

Thanking you again and again, believe me,

Your sincere admirer,

DOROTHEA DA PONTE WILLIAMS.

Other interesting and appreciative letters have been received from Lewis P. Crag, Frances Willard Huston, G. O. Basil Hacker, Marian Tyler, Grace L. Barber, Edward J. Dimock, Katherine D. Barbour, Sidney Meise, Gertrude F. Nichols, Barbara O. Benjamin, Milly Pearson, Mildred E. Verral, Henrietta McIvor, Eleanor Gill, Louisa J. Spear, Ruth G. DePledge, Persis Parker, Mildred Quiggle, Miriam H. Tanberg, Mary Parker, Elizabeth M. Kuggles, C. Rachel Clarke, Ethel Bohmann, Muriel L. Gibson, Kathie Macphail, Elizabeth M. Kim, Louise C. Jones, Harry W. Hazard, Jr., Grace Westbrook, The A. Temp, Emma M. Guenther, Elizabeth C. Burt, and Dorothy St. John Mildmay.

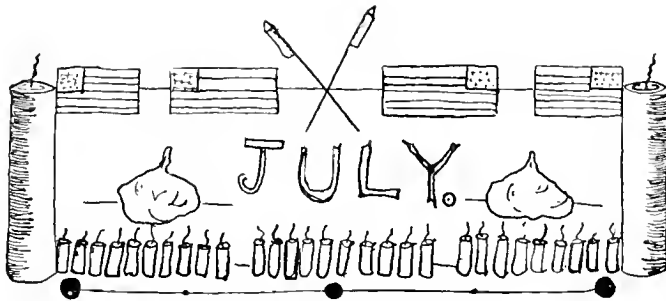

"A HEADING FOR JULY." BY PRISCILLA A. WILLIAMS, AGE 7. (SILVER BADGE.)

THE ROLL OF HONOR.

No. 1. A list of those whose work would have been used had space permitted.
 No. 2. A list of those whose work is considered worthy of encouragement.

<p>VERSE 1.</p> <p>Marjone C. Paddock Robert Strain, 3d Ray Randall Hazel L. Raybold Jessie Freeman Foster Kate Sprague DeWolf Hélène Mabel Sawyer Beulah H. Ridgeway Leland G. Hendricks Jeanie G. Knowles Elizabeth Roberts Eleanor Johnson Natche Wurts Emily Rose Burt Maud Dudley Shackelford Marguerite Stuart Louisa F. Spear Rachel M. Crane Mary Travis Howard Elliot O. Adams Jessie E. Wilcox Catharine E. Jackson Katharine M. Sherwood Marjorie Peck Gladys Nelson Marguerite Weed Nannie Clark Barr Primrose Lawrence Frances Paine Mary Winslow Teresa Vitucci Harold R. Norris Dorothy St. John Mildmay Floy DeGrove Baker</p>	<p>Corinne Bowers Florence Short Ethel Dickson Arthur Albert Myers Dorothy H. Ebersole Myrtle Moore Greta Torpadie Björkstén Rispah Goff Mabel Winslow Alice Blaine Damosch Phyllis Brooks Elizabeth J. Phillips Wilbur K. Bates Thoda Cockroft Margaret S. Caldwell Dorothy Stabler Carl H. Weston Marjorie Clark Linda W. Baker Adelaide Loughhead John L. Taylor Margaret Ewing Marie Armstrong Florence Dean Anna Eveleth Holman Sylvia Mary Allen Margaret Dornen Elizabeth Banks Ruth Albert Josephine E. Swain Louise E. Grant Frida Tillman Dorothy Smith C. Marie Flummerfelt Frances Hodges Rachel Thayer Mary Emily Bailey Katharine B. Newmann Julia S. Bail Anita Nathan Esther Galbraith Catharine H. Straker Ise M. Neymann Helen Lathrop Mary Comstock Charles Irving Stewart Arthur Kennard Underwood Margaret E. Harper Isabel Weaver Melanie F. Deutsch Marie Perot Zesinger Josephine Freund Sylvana Blumer Ormstead C. Gordon Gladys M. Adams Helen B. Jessup Gertrude Ford Mary M. Dabney Hiram Langdon Ken-nicott Joseph A. Clark</p>	<p>PROSE 1.</p> <p>Gladys Halter Julia G. Moore Carolyn Houston Emily Cale Morris Gilbert Bishop Valerie Greene Vincent Intirie Lulu Adele Pearson Harnette Kyler Pease Gladys M. Cornish Theodora B. Elliot McCormick Dorothy Gibson Madelaine F. H. White Sarah F. Elliott Margaret Douglass Gordon Mabel Robinson Katharine Norton Francis Marion Miller Marie A. Pierson Grace E. Moore Thelma Elkins Charles Curtis Amidon Howard Murphy Edna Anderson Dorothy Barclay</p>
---	---	--

<p>VERSE 2.</p> <p>Frances O. Nichols Monica Shannon Clarence B. Reemelin Ella E. Preston Frances Raymond Hill Walter MacFwen Mary Elizabeth Maur Roscoe H. Vining Helene Esberg Bessie Emery Gratia B. Camp Erma Bertha Mixson Florence Isabel Miller Eva Harrington Margaret Albert Alda Palmer Mildred Seitz Marjorie W. Lee Joseph P. D. Hull Alta M. Lockwood Marguerite Eugénie Stephens Dorothy Coit</p>	<p>PROSE 2.</p> <p>Eddie Warner Adelaide Durst Harold I. Jeffrey Mabel Leescombe Margaret Abbott Helen Leslie Follansbee Gwendolen Tugman Elsie F. Weil Twila A. McDowell J. Murphy Mary Louis Smith Margaret Twitchell Benjamin Cohen Catharine Wharton George, Erskine Heard Lola Hall Carl Olsen Marion Louise Fox Harry E. Popp Vera V. van Nes Mary Pemberton Nourse Rosamond Baker Harris Isabel McCarthy Brooks Shepard Esther Avid Hilda Torrop Dorothy Bedell Julia Dorsey Musser Elizabeth R. Marvin Lillian M. Hynes</p>
---	---

Helen Parfitt Katherine Dulcebella Barbour Kate Fishel Sidney Cohen Vera Demens Katherine Mize Walter Burton Nourse	Evelyn Buchanan Julia A. Buchanan Myron C. Nutting Marie Seton Anne Furman Goldsmith Lillian Buckman Madeleine Sweet Helen M. Copeland Hilda Kohr Rena Kellner Lucy Pedder Ruth Cutler Margaret Helen Bennett M. Harrison Louis A. Jutras Eunice Clark Barstow Fred Graham Jessie L. Taylor Martha Carroll Norvin McQuown Rosamond H. Coney Mildred C. Jones Dean C. Throckmorton Delmar G. Cooke Frederick Greenwood Margaret A. Dobson Marguerite Strathy Helen Reading Sara D. Burge Lillie Lemp A. Hart Edythe Crombie Marion K. Cobb Mary Ellen Willard Carl B. Timberlake Emily W. Browne Alice Noble Rita Wood Olive Munde-Cooke Lauren Ford Dorothy Ochtman Fanny C. Storer Charlotte Waugh Corinne H. Smith William W. Westring, Jr. Mary Clarke
--	--

DRAWINGS 2.

Ruth Walden Rachel Wyse Hobart Fairman Hester Noyes Irving Beach Katherine Gibson Louis P. Hastings Marguerite McCormick Elinore Clark John Eliot Woolley Viewa Fisher Rebecca Wyse Helen Wilson Kathleen Buchanan Genevieve Morse Bessie Bocage Maria S. Bullitt Theresa R. Robbins Nelly B. Lewis Esther T. Root Ruth Brockington Tom Moffett Flora Sheen Eugenia Vansant Webb Mellin Siemens Elizabeth Cockle Margaret Osborne Frederic S. Murray Frieda Funck Mary Pyne Hazella F. Bradley R. J. Harrison Mildred E. Verral Lydia C. Gibson Kate M. Horton Helen L. Allen Thomas League Nancy E. Barton Katharine L. Carrington Ruth Lawrence Carroll Clara Shanafelt	M. Harrison Louis A. Jutras Eunice Clark Barstow Fred Graham Jessie L. Taylor Martha Carroll Norvin McQuown Rosamond H. Coney Mildred C. Jones Dean C. Throckmorton Delmar G. Cooke Frederick Greenwood Margaret A. Dobson Marguerite Strathy Helen Reading Sara D. Burge Lillie Lemp A. Hart Edythe Crombie Marion K. Cobb Mary Ellen Willard Carl B. Timberlake Emily W. Browne Alice Noble Rita Wood Olive Munde-Cooke Lauren Ford Dorothy Ochtman Fanny C. Storer Charlotte Waugh Corinne H. Smith William W. Westring, Jr. Mary Clarke
---	---

DRAWINGS 1.

Richard A. Reddy Alice Shirley Willis Claudia Paxton Old Harold G. Preul Gordon Ashford Mitchell Helen L. Wilson John D. Butler Roland I. Stringham Stassto Azuy Lucy E. B. Mackenzie Monica Peirson Turner Bernice Corson	Richard A. Reddy Alice Shirley Willis Claudia Paxton Old Harold G. Preul Gordon Ashford Mitchell Helen L. Wilson John D. Butler Roland I. Stringham Stassto Azuy Lucy E. B. Mackenzie Monica Peirson Turner Bernice Corson
--	--

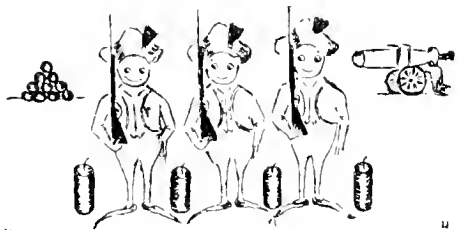

"Let Independence Be Our Boast"
 "THE OLD GUARD." BY EDNA BEHRE, AGE 15.

Margaret Spencer-Smith William C. Engle Rita Ward Elisabeth MacDougall Ethel Messervy Robert H. Gibson Leicester Spaulding Anna Graham Wilson Marguret B. Richardson Rexford Hawley Elizabeth Jackson Howard Wallingford Lois Macgavock Sybil Emerson Katharine L. Havens Harriet Eager Dorothy Curtis Aline J. Macdonald James Harrison	Alice Havens Arthur Jennings White Arthur H. Wilson Audrey Huston Margaret F. Upton Robert F. Granger Margaret Janeway Margaret Burroughs Cornelia L. Walker Gilbert Durand Ruth A. Woodruff Ailyn R. Frager George Hill Lawrence V. Sheridan Jane Elliot Buchanan Phyllis B. Mudie-Cooke W. J. Hickmott, Jr. Gertrude M. Howland
--	--

Susan J. Appleton
 Adelaide Ellithorpe
 James M. Walker
 H. Ernest Bell
 Roger I. Twitchell
 Walter Creigh Preston
 Knight Woolley

PHOTOGRAPHS 2.

Dorothea da Ponte
 Williams
 Helen Wing
 Eleanor Cory
 Philip Simons
 William Whitelock
 Marjorie Betts
 Ada G. Kendall
 Jack Platt
 Stella Heinsheimer
 Alan F. Winslow
 Joseph M. Hayman,
 Jr.
 Joseph C. Buchanan

Godfrey R. Thorne
 Horace McK. Hatch
 John Sittle
 Arthur Blue
 Theobald Forestall
 Phyllis Eaton
 Mary Pyne
 Dorothy Eaton
 Helen L. K. Porter
 Charlotte Eaton
 Julian Janeway
 Charles Dodge Hoag
 Ruth W. Leonard
 Elizabeth Henn
 Helen F. Price
 Granville A. Perkins
 Anita M. Smith
 Katharine Robinson
 Donald McIlvaime
 Donald Armour
 Gertrude D. Wood
 J. Rose-Tripp
 Gertrude O. Daniels

Katherine Hobart
 Ely Raymond
 Jeanette Langhaar
 Alice B. Carleton
 Randolph Payson
 Donald F. Hood
 Nathaniel S. Thayer
 Charles McKnight
 Marguerite Hyde
 Anna C. Buchanan

William Fielden
 Elwood Bachman
 Dorothy Williams
 Edith M. Andrews
 Rene Piereroux
 Alice Durand
 Elsa van Nes
 Elsie Woimser
 Joseph S. Webb
 Hillard Comstock
 Marjorie Nind
 Robert S. Erskine
 Hugh McMillan Kin-
 gery
 Olive A. Granger
 Genevieve A. Houra-
 han
 Richard de Charus, Jr.
 Elsie Garland
 Henry Morgan Brooks
 Lawrence Sherman
 Thyra Jeremissen
 Margery Wylie
 Alice L. Cousins

Ruth I. Clay
 Bertha D. Reimer

PUZZLES 1.

Agnes R. Lane
 Andree Mante
 Regine Mante
 Odette Mante
 Marguerite Jervis
 Elizabeth Beal Berry
 J. Wells Baxter
 Fred Dohrmann
 E. Adelaide Hahn
 Sybil Xavier Basford
 Benjamin I. Miller
 Fred Stedman
 Elizabeth Palmer
 Loper
 Mary E. Ross
 Edith L. Kaskel
 Katharine Putnam
 Erwin Janowitz
 Eleanor V. Coverly



"A JUNE FANCY." BY JESSIE C. SHAW, AGE 17.

PUZZLES 2.

Marian Willis Tyler
 Robert L. Moore
 Eleanor Hussey
 Lewis B. A. Mc-
 Dowell
 John M. Stevens
 Margaret Curtis
 Willie O. Dickinson

NOTICE.

ANSWERS to the advertising competitions of the League should be addressed plainly to that department, as the two have different editors, and contributions are likely to be misplaced and lost when sent to the wrong department. *This is important.*

NEW CHAPTERS.

No. 817. Alice M. Savage, President; Elsie Moore, Secretary; six members. Address, 52 Grant St., Somerville, Mass.

No. 818. "Sunshine Society." Ruth McKinley, President; Grace McKinley, Secretary; six members. Address, 208 Butler St., Lansing, Mich.

No. 819. Mary de Saussure, Secretary; seven members. Address, 16 Church St., Charleston, S. C.

No. 820. Leonard Rivers, President. Thelma Claiborne, Secretary; six members. Address, 70 Cassitt Library, 249 Orleans St., Memphis, Tenn.

No. 821. Ruth Tusel, President; Lawrence Booth, Secretary. Address, 745 Westlake Ave., Los Angeles, Cal.

No. 822. "The Wild Violet." Catherine Flint, President; three members. Address, Wood Brae, Bellows Falls, Vt.

No. 823. "Le Moyne Institute League." Leonard Rivers, President; Katherine Goens, Secretary; sixty-five members. Address, 629 Wickes Ave., Memphis, Tenn.

No. 824. "G. G." Dorothy Connor, President; four members. Address, 1116 9th St., Des Moines, Iowa.

No. 825. "The Merry Makers." Buford Brice, President; seven members. Address, 1404 Bacon St., Washington, D. C.

No. 826. George M. Kelly, President; seven members. Address, 76 Quincy St., Brooklyn, N. Y.

PRIZE COMPETITION No. 70.

THE St. Nicholas League awards gold and silver badges each month for the best poems, stories, drawings, photographs, puzzles, and puzzle-answers. Also cash prizes of five dollars each to gold-badge winners who shall again win first place. This does not include "Wild Animal and Bird Photograph" prize-winners.

Competition No. 70 will close **July 20** (for foreign members **July 25**). The awards will be announced and prize contributions published in *ST. NICHOLAS* for **October**.

Verse. To contain not more than twenty-four lines. Title: to contain the word "Camp" or "Camping."

Prose. Story, article, or play of not more than four hundred words. Subject, "The Fish that Got Away."

Photograph. Any size, interior or exterior, mounted or unmounted; no blue prints or negatives. Subject, "Vacation Days."

Drawing. India ink, very black writing-ink, or wash (not color). Two subjects, "The Fence Corner" (from life) and a Heading or Tailpiece for October.

Puzzle. Any sort, but must be accompanied by the answer in full, and must be indorsed.

Puzzle-answers. Best, neatest, and most complete set of answers to puzzles in this issue of *ST. NICHOLAS*. Must be indorsed.

Wild Animal or Bird Photograph. To encourage the pursuing of game with a camera instead of a gun. For the best photograph of a wild animal or bird taken *in its natural home*: **First Prize**, five dollars and League gold badge. **Second Prize**, three dollars and League gold badge. **Third Prize**, League gold badge.

RULES.

ANY reader of *ST. NICHOLAS*, whether a subscriber or not, is entitled to League membership, and a League badge and leaflet, which will be sent on application.

Every contribution, of whatever kind, *must* bear the name, age, and address of the sender, and be indorsed as "original" by parent, teacher, or guardian, *who must be convinced beyond doubt that the contribution is not copied*, but wholly the work and idea of the sender. If prose, the number of words should also be added. These things must not be on a separate sheet, but *on the contribution itself*—if a manuscript, on the upper margin; if a picture, *on the margin or back*. Write or draw on *one side of the paper only*. A contributor may send but one contribution a month—not one of each kind, but one only. Address:



"TAILPIECE." BY CHAR-
 LOTTE ST. G. NOURSE,
 AGE 10.

The St. Nicholas League,
 Union Square, New York.

BOOKS AND READING.

SUGGESTIONS FOR THE GIRLS' READING. The Marchioness of Londonderry has been setting forth in an English paper her suggestions as to the proper reading for young girls. Evidently she believes that, before twelve years of age, girls should become well acquainted with the best fairy stories, as, beginning with "Nursery Rhymes," she puts next the fairy stories by the brothers Grimm and those by Hans Andersen. The list, as it goes on, does not strike us as particularly well chosen. For instance, she includes the works of Captains Marryat and Mayne Reid. Most of the books by Reid and by Marryat are too old for girls of that age, and many of them are objectionable because of their sensational features.

She recommends, however, a book well worthy of attention and one seldom read to-day, "The Voyage of the Little Fox," by McClintock, certainly one of the little classics of Arctic exploration, and a most delightful true story for girls or boys.

A book she names in her list is "Self-Help," by Samuel Smiles. It would be interesting to learn on what grounds this is recommended, as it is a series of biographical notes meant chiefly to help poor young men to get on in the world.

At a later age, the same lady would have girls read rather deeply in history, and accompany the historical reading with such novels as Kingsley's "Westward Ho!" and Scott's in so far as they refer to the sixteenth century. We quote the end of the article in which these books are named:

Reading in this way, a girl becomes saturated with the subject; she breathes the atmosphere of the period she is reading about, and learns to take an interest in the lives of great men and women, and realizes the consequences of actions in real life; her judgment would be trained and her character formed by some such plan.

A STORY OF THE VIKINGS. AMONG the serials that were published in *ST. NICHOLAS* not long ago was a charming little story by Allen French entitled "Sir Marrok." Before the publication of that story in this magazine, Mr. French had won a great many friends

by his earlier serial of an entirely different character, "The Junior Cup," a story of life in a boys' boarding-school. Perhaps some of Mr. French's *ST. NICHOLAS* friends would be glad to be reminded that Mr. French has written within a few months another story for young people well worth their attention in "Rolf and the Viking's Bow." He has made real for us the life of the old Northmen in their own home, and has also drawn a hero worthy of the traditions attaching to this land of brave men. It is rather remarkable that each of Mr. French's stories has so few points of resemblance to any other. They differ in time, in place, and in characters, and even in style of telling.

IN THE ENCYCLOPEDIA. If you will look at the first entry under the letter G in the "Britannica," — which is an article on that letter itself, — you will find some interesting examples of words which may begin with either G or W, such as warrantee, guarantee; wage, gage; guise, wise. Under each letter of the alphabet in the encyclopedia you will find some good reading, for the tracing of the history of letters leads one among interesting bits of history. The letters I and J, and K and C, may also be consulted, during some rainy day, in your library.

AN INTRODUCTION AMONG THE BOOKS RECENTLY PUBLISHED. AMONG the books recently published, there is one by S. R. Crockett meant to serve a very delightful purpose. Having learned that certain children, intimate friends of his, declared they could not read Sir Walter Scott, it occurred to Mr. Crockett that it would be wise to make such selections from a few of the more stirring Waverley Novels as would teach the children something of the delights that were in store for them if they would give the time necessary to make a beginning in any of these charming books.

There is no use in pretending that the reading of one of the Waverley Novels is quite so simple a matter as the reading of ordinary boys' or girls' books. The usual juvenile story contains so little in plot or in incident, displays so little character, and accomplishes so trivial a re-

sult, that it can begin almost anywhere, wander here and there without especial aim, and leave off at one place almost as well as at another. With Scott there is always a depth of purpose and a breadth of view making it necessary for him to lay a foundation before constructing the lighter parts of his novels. Some young readers are too impatient to make themselves acquainted with the conditions Scott wishes them to understand before taking up his story. As a result, these young critics read a few pages in a great masterpiece, declare it dull, and close the book forever — to no one's loss but their own.

"Redcap Tales," the title given by Mr. Crockett to his introduction to the Waverley Novels, is meant to show young readers of this sort all the delights they are losing. The book is beautifully made, and is exquisitely illustrated in color. It would make a good companion for either boy or girl during this vacation.

VACATION BOOKS. NOT long ago in this department we asked for suggestions as to books suitable to take upon a camping trip. Then came the question as to whether boys and girls would care to take with them the works of any poet. A bright reader who lives in Maine writes to us to say that her first choice for such a trip would be her volume of Tennyson. But we will let her talk direct to you. She says: "Often and often, when the question of what to read arises, I turn to the top shelf of my book-case, where my poets live. The one who comes out to talk to me most is Tennyson, with Longfellow a close second. Dear Sir Walter is a great favorite, too, and Wordsworth's poems are well thumbed. So, you see, there is one bookworm, at least, to prove unfounded your fears that younger readers do not like poetry."

We should be very glad if so discriminating a lover of poetry would send us a few words of advice to other young girls, to aid them in selecting poems that would prove lifelong friends.

READERS OF DICKENS. WHAT would the United States do without the State of Massachusetts? Here is a sharp-eyed critic who dates her indictment from Worcester, and delivers this terrible charge: "I have never noticed in the Books and Reading department anything about Charles Dickens." This hurts

her feelings, as she is especially fond of that author's works. We fear that there is some justice in our young assailant's accusation — not that it is entirely true, for we have never made up a list of books recommended for young people's reading without including those stories of Dickens's best fitted to please and help the younger readers.

Perhaps the reason that their mention is rare is the belief upon our part that the greater authors are so well known that there is little to be said about them personally. We should be very glad if our vigilant correspondent would send us a little letter, giving briefly the main facts about the life of Dickens, told in such a way as to interest young readers. Certainly his career was, in a way, almost as remarkable as that of Napoleon Bonaparte, and, some will say, undoubtedly of greater use to the world.

TWO FORGOTTEN STORIES. WE thank another correspondent for sending us the names of two books which she recommends highly, although she says they are almost forgotten by young readers. These are "Caleb" and "The Little Lass," by Mary Paynter. Who will tell us more about these two volumes?

AN ERROR IN ENGLISH. EVEN the greatest authors now and then make a little slip in their English. Thus Sir Walter Scott in his "Legend of Montrose" has this sentence: "But ere Montrose could almost see what happened, Allan McAulay had rushed past him." The "almost" should come before "ere," in order to express the author's meaning.

A NEW "GIRLS' BOOK." DURING the vacation, when there come those inevitable gray days that confine you to the house, and you long for some little bits of amusing handiwork to occupy restless fingers without a great strain upon the resting mind, it would be hard to find a better help than the little manual entitled "Handicrafts for Girls," by the Beard sisters. Most books of this sort have been upon the market for a great many years, and are no more than copies of one another. But this American book is new, carefully prepared, and thoroughly practical. Here you will find designs and devices with which older girls and boys can amuse younger ones, and, incidentally, be themselves amused.

EDITORIAL NOTES.

IN the May and June numbers ST. NICHOLAS described some of the most characteristic of American trees, and showed in outline the form of their leaves.

On pages 812 to 815 of this issue are shown, in the briefest space, pictorial outlines of the branch, twig, leaf, and fruit of fourteen of the principal American fruit and nut bearing trees, with added diagrams of the mulberry and cedar. The height of the tree in every case may be judged by comparing it with the height of the child standing beside it.

By the aid of these three contributions, ST. NICHOLAS readers should be able to distinguish and name correctly most of the common American trees.

"The Swallows' Revenge," on page 793 of this number, narrates a story of bird life so remarkable that it seems almost incredible. But in answer to a special inquiry the author writes that the story is a record of actual facts. Here is an extract from her letter.

SHIRBURN,
WALLINGFORD, ENGLAND.

... The incident of the swallows walling up their nest, with the sparrows that had stolen it inside, is perfectly true. It happened on this place many years ago, but I well remember it, and there are several other people who can vouch for it.

MARGARET WATSON.

THE LETTER-BOX.

PORTLAND, ORE.

DEAR ST. NICHOLAS: Here is a picture of a tree-house built by brother Alan and me in a tall fir-tree in our back yard.



A HOME-MADE TREE-HUT.

The tree is over one hundred feet high, and we put an American flag on the top. The house is built in among the lower branches, about twenty feet from the ground. We rigged up a rope hoist to pull up the heavy timbers for the floor-joists. The house is eight feet long and seven feet wide and five feet high. We made a book-case out of a box, and kept all of our books and papers up there, where we spent most of our time during our summer vacation.

We made two beds in the main room, and slept up there on warm nights. We invited our father to spend a night with us, and he said the bed was more comfortable than a Pullman-car berth. He liked it so well he slept with us several nights. Alan is twelve years old, and I am ten. We planned and built the house by ourselves and enjoy it. Our sister takes ST. NICHOLAS, and we all read it and like it very much.

Yours truly,

PENN ROWE.

MARASH, TURKEY.

DEAR ST. NICHOLAS: The nineteenth of January was the Armenian Christmas. In the morning one of the American teachers in the Marash College, Miss Welpton by name, came to our house and asked me if she could cut out some advertisements from the magazines. Then she told me that the night before she had asked the girls what they would wish for if a fairy should come and ask them. These wishes, as far as she was able, she was cutting from advertisements. One girl wished for a cheerful face. She was given one of an advertisement of a breakfast food showing "The smile that won't come off." Several girls wished for Miss Welpton's photograph. Miss Welpton remembered this little Irish song:

I sent to her a picture — I did upon my word;
Not a picture of myself, but a picture of a bird.

So she gave each a picture of a bird. One girl wished for a coat and six thousand pounds. She got a doll's purse, which, she was told, was waiting for the money. Then, besides these jokes, each girl got a picture from Miss Welpton and a bag from Miss Blakely.

EDITH MACALLUM.

AN old-time friend of ST. NICHOLAS sends us this sketch, which is supposed to represent



THE AMERICAN EAGLE ON THE FIFTH OF JULY.

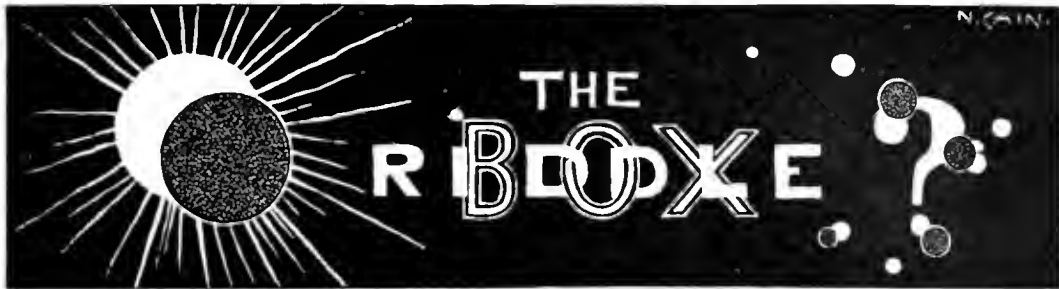

ANSWERS TO PUZZLES IN THE JUNE NUMBER.

ZIGZAG. Fairyland. Cross-words: 1. Frost. 2. Fancy. 3. Shift. 4. Hairy. 5. Fairy. 6. Daily. 7. Graze. 8. Inane. 9. Dozen.

SQUARES AND DIAMONDS. I. 1. Gnats. 2. Niche. 3. Acrid. 4. Thing. 5. Sedge. II. 1. Olive. 2. Linen. 3. Inert. 4. Verse. 5. Enter. III. 1. E. 2. Ant. 3. Ensue. 4. Tub. 5. E. IV. 1. E. 2. Ax. 3. Exile. 4. Elm. 5. E. V. 1. Maple. 2. Avail. 3. Paved. 4. Liege. 5. Elder. VI. 1. Eight. 2. Idler. 3. Glare. 4. Heron. 5. Trend.

TRIPLE BEHEADINGS. Battle of Chickamauga. 1. Bob-hin. 2. Disaster. 3. Mut-ton. 4. Sey-the. 5. Gar-land. 6. Dep-end. 7. Uni-on. 8. Sel-fish. 9. Pro-cure. 10. Ore-hard. 11. Pol-ice. 12. Ker-chief. 13. Tur-key. 14. Hom-age. 15. Dis-miss. 16. Fin-ale. 17. Ven-us. 18. Fra-grant. 19. Ali-as.

ILLUSTRATED MUSICAL PUZZLE:

Build me straight, O worthy master;
Stanch and strong,
A goodly vessel
That shall laugh at all disaster
And with wave and whirlwind wrestle.

TO OUR PUZZLERS: ANSWERS to be acknowledged in the magazine, must be received not later than the 15th of each month, and should be addressed to ST. NICHOLAS Riddle-box, care of THE CENTURY Co., 33 East Seventeenth St., New York City.

ANSWERS TO ALL THE PUZZLES IN THE APRIL NUMBER were received, before April 15th, from "Chuck"—John Farr Simons—"Allil and Adj"—Nessie and Freddie—Jo and I—Hamilton Fish Armstrong—Florence G. Mackey—Bessie Garrison—Dorothy Rutherford—Louis Six Weiss.

ANSWERS TO PUZZLES IN THE APRIL NUMBER were received, before April 15th, from M. Budd, 1—Katharine W. McCollin, 3—K. Stone, 1—S. D. White, 1—E. H. Parker, 1—Mary G. Bonner, 3—Helen L. Patch, 5—R. V. Williamson, 1—Edwin and Beatrice, 2—Uncle George, 1—Rose Caroline Huff, 8—"Duluth," 7—"Fritz and his Cousins," 4—C. C. Anthony, 8—Mary E. Askew, 5—Bessie Sweet Gallup, 5—Gerald O. B. Hackett, 1—Emma D. Miller, 7—Wm. M. Yarker, 2—Marion Patton, 4—L. S. Clapp, 1—Andrée Mante, 4—Harriet Binghamon, 7.

CHARADE.

A WAYSIDE shelter is my first;
My next, a river small;
Mightier than the sword, my third;
My fourth comes from a fall.
Liberty and freedom my whole,
Dear to every patriot soul.

GRETCHEN NEUBURGER
(League Member).

CENTRAL SYNCOPATIONS.

(Silver Badge, St. Nicholas League Competition.)

EXAMPLE: Syncopate an animal, and leave a garden implement. Answer, ho-r-se, hose.

1. Syncopate pertaining to the sun, and leave to fly.
2. Syncopate to drift along, and leave tasteless.
3. Syncopate a feminine name, and leave epochs.
4. Syncopate a character in "Oliver Twist," and leave gladly.
5. Syncopate stories in a building, and leave portions.
6. Syncopate a weapon, and leave part of a ship.
7. Syncopate paved, and leave fastened.
8. Syncopate a masculine nickname, and leave crafty.
9. Syncopate an outcry, and leave closed.

The merchant's word
Delighted the master heard,
For his heart was in his work,
And the heart
Giveth grace unto every art
The Building of the Ship.

ENIGMA. Anemone. An m on e.

ALLITERATIONS. 1. S. D. T. 2. F. P. B. 3. G. C. S. 4. Q. L. C. 5. B. S. T.

DOUBLE BEHEADINGS AND CURTAILINGS. Vacation. 1. Bel-iev-er, vile. 2. Ic-e-pla-nt, pale. 3. Mi-scar-ry, cars. 4. Cl-emat-es, mate. 5. Ex-trem-es, term. 6. Pi-ccin-ci, nice. 7. An-emon-es, omen. 8. Mi-nist-er, inst.

REVERSIBLE SQUARES. From 1 to 2, dial; 2 to 1, laid; 2 to 3, Leon; 3 to 2, Noel; 1 to 4, Dort; 4 to 1, trod; 2 to 5, leat; 5 to 2, tacl; 3 to 6, névé; 6 to 3, even; 4 to 5, tort; 5 to 4, trot; 5 to 6, time; 6 to 5, emit; 4 to 7, teel; 7 to 4, leat; 5 to 8, tide; 8 to 5, edit; 6 to 9, Fros; 9 to 6, sore; 7 to 8, live; 8 to 7, evil; 8 to 9, ckes; 9 to 8, seke.

CONCEALED WORD-SQUARE. 1. Traced. 2. Remove. 3. Amuses. 4. Cosine. 5. Evener. 6. Desert.

10. Syncopate an arbor, and leave a South African colonist of Dutch descent.

The ten syncopated letters will spell the surname of a famous man. WILLIAM SHIPMAN MAULSBY.

MULTIPLE CROSS-WORD ENIGMA.

(Silver Badge, St. Nicholas League Competition.)

My firsts are in harlequins, not in fate;
My seconds, in maundering, not in eight;
My thirds are in nimbleness, not in loom;
My fourths, in sincerity, not in bloom;
My fifths, in pedantic, not in glow;
My sixths, in Zamindar, not in blow;
My sevenths, in vanity, not in save;
My eighths are in coaxed, but not in brave;
My ninths are in herring, but not in dumb;
My tenths are in boisterous, not in thumb;
My elevenths, in filibuster, not in try;
My twelfths, in arboriculture, not in cry;
My last is in xanthous, but not in tree;
Now, if you are clever, you will see:
An author whose fairy-tales all do delight;
A magazine which I am sure is just right;
And, lastly, a story, both witty and new,
And by this magazine it is brought unto you.

DAVID FISHEL.



F. P. HARDSON

"QUEEN ZIXI GREETED BUD AND HIS SISTER AND AUNT
WITH GREAT KINDNESS."

ST. NICHOLAS.

VOL. XXXII.

AUGUST, 1905.

NO. 10.

THE COMMODORE'S CUP.

BY WILLIAM B. MCCORMICK.

LON MARSHALL stood in the post-office, staring wistfully at the notice, tacked up on the bulletin-board, of the forthcoming annual regatta of the Squam Yacht Club. The particular thing that caught his eye was the second money prize of fifteen dollars for sailing-dories, offered by the commodore. There were other prizes, of course: the much-coveted silver cup, called "the Commodore's Cup," for knockabouts, pennants for the raceabouts and half-raters, and a first money prize of twenty-five dollars for the fishermen's sloops.

But the one he stared at so longingly was that second prize. For he felt certain that the *Wanderer*, his sailing-dory, could beat anything in the Cove or up Squam River. The trouble was to get the entrance fee of two dollars. The commodore was a very generous man, as every one in Squam knew; but he believed that it was only fair that the local fishermen should pay to enter the race. Two dollars, however, stood between Lon and the prize.

He shifted his crutch and was about to stomp away on it and his one leg, when a familiar voice called out cheerily, "Good-morning, Lon! What 's the trouble now?"

It was Commodore Black who spoke to him, and at the sound Lon whipped around and said quickly: "Good-morning, sir! I

was trying to think of some way to make two dollars."

"Two dollars," echoed his companion, "What for? Want to see the circus?"

"No, sir," Lon replied emphatically. "I want a chance to win that dory prize, that 's all."

"Is n't lobstering paying this season, Lon?"

"Pretty well, sir; but Alice and Dan have been sick, and it takes all that mother and I can make to pay the doctor's bills and keep them comfortable. That fifteen dollars would come in mighty handy now."

"Hum!" ejaculated the commodore. Then Lon turned away and walked up the road. He was cudgeling his brains to think up some plan whereby he might raise the much-desired two dollars. He had enough lobsters in the "car" down at the dock to be worth that, if the cottagers would only buy them. But on his rounds that morning very few seemed to want lobsters at all.

Lon Marshall was fifteen years old, and the loss of his right leg had occurred two years before, through his being thrown from a trolley-car. That happened the winter his father died; and as soon as Lon was able to get about on the rough crutch he had made himself, he worked as hard as he could helping his mother in keeping a home for Alice and Dan.

His father had left him a fast sailing-dory, and, however much Lon was hampered on land by the loss of his leg, he was as good as the next one on board a boat. The villagers took a pride in his ability as a boat-sailer; and the cottagers liked him for his cheerfulness and the way he worked. But both as a lobsterman and as a boat-sailer he had one very active rival. This was Bob Richards, the postmaster's son.

Lon and his mother discussed the situation while they were eating dinner, and Mrs. Marshall suggested that he should make another tour of the hotels and cottages that afternoon and remind the people that the morrow was "Squam Day," and more lobsters would be needed to feed the crowd of visitors attracted by the boat-races. Lon started out as soon as dinner was over, but before he had reached the first cottage, Mrs. Black, the commodore's wife, called to him from her phaëton.

"Oh, Lon," she cried, as she reined in her horse, "have you any lobsters on hand?"

"Yes, ma'am," replied Lon. And, to his wonder and delight, she ordered ten from him, to be delivered at once. Then she paid him the amount of his "bill," which was three dollars and a half. Lon went back to the cottage with as near to a run as his one leg would allow.

"Mother," he cried, as he burst into the kitchen, "I've got it!" And he threw the money down on the table.

"So you have, my boy. But do you really think you ought to go into that race? Is n't it a kind of gambling?"

Lon brushed his doubts aside by saying he guessed "if it were gambling Commodore Black would n't put the prize up." Mrs. Marshall had no argument to advance against that statement, for in Squam everything the commodore did was considered just right.

Lon took the two dollars, went down to the club-house, and entered his dory for the race.

"Hope you'll win, Lon," said the steward as he wrote, "Alonzo Marshall, *Wanderer*. Paid." on the list of entries. "You want to look out for Bob Richards, though. That 'ere dory of his is right smart."

"Oh, I think I can beat him, Jim, unless he outwits me with some surprise. He's a good sailor, but I'm not afraid of Bob or the *Arrow*."

The race was set for the next day, the start being at ten o'clock. But, race or no race, Lon had to go out in the bay to overhaul his lobster-pots and take up his night's catch. So he left home before daybreak the next morning, rowed out to the "Ledge," and after taking up one set of pots baited and dropped the second set overboard.

Before seven o'clock he had transferred his catch to the "car" in which he kept them, and then started to haul the *Wanderer* up on the beach to give the bottom a scrubbing off. When he had finished this and had overhauled the rigging of his spritsail and jib, it was time to make his way out to the starting-point off the lighthouse.

It was a beautiful morning, with just the kind of a breeze Lon liked. It was coming out of the southwest in heavy puffs that were dangerous to a craft not sailed by skilled hands. Lon liked it, not because he was fearless, but because he knew just how hard a blow the *Wanderer* would stand. And as he knew Bob Richards was nervous on the water, he counted more than ever for this reason on being able to beat him. He knew that when the heavy puffs came tearing across the bay, whipping it into foam, Bob would throw the *Arrow* up in the wind, thus losing headway. Meanwhile the *Wanderer* would be keeping steadily on her way, even if Lon had to climb out to windward to do it. That was a part of sailing a race.

As Lon ran out to the starting-point where the commodore's schooner lay at anchor, he was startled at catching sight of Marion Darcy, the commodore's niece, out sailing alone in a cranky little rowboat of her own. It had been converted into a sail-boat by the addition of a centerboard and a spritsail that was much too big for it, Lon thought. But Marion had been brought up around the water, was thoroughly at home in boats, and could swim; and her uncle allowed her to do pretty much as she pleased with her boat. Her greatest danger, Lon knew, lay in her fearlessness and ignorance of the faults of her cranky craft.

When the boy first caught sight of her, she was sailing to leeward, running before the wind as Lon was. And, as usually happens with a cranky craft, Marion's boat was yawing badly,



HE HEADED THE WINDERL FOR THE DISABLED BOAT AND STRUGGLING GIRL (SEE NEXT PAGE)

and threatening to roll the boom under. He ran off to leeward of her and then hailed her:

"Oh, Miss Marion, don't you think you are carrying too much sail? It's blowing pretty fresh to-day. It's coming harder every minute."

"Too much sail?" she shouted back across the water; "not for me. I could n't go to windward without the sprit up. If you don't look out I'll beat you to the start."

This was a joke, for Lon was gradually drawing away from her. As he neared the starting-point the thought came into his head to run alongside the schooner and speak to the commodore of the danger Marion was in. But just then the warning-gun for his class sounded, and he went about, hoisted the jib, and began "jockeying" for a good position with the four other dories that were entered for the race.

The *Wanderer* stood away from the line for as near two minutes as Lon could count. Then he went about and ran down to the starting-line, with Bob Richards following his every move. The other three dories were having a battle between themselves on the opposite tack, for their owners realized that they were bound to take third place between them if Lon and Bob stayed in the race. Much to Lon's disgust, as he neared the line he saw he was ahead of time, and he had to jibe over and make a tack away from it. Bob just caught the gun-fire at the proper time, which gave him the advantage at the start.

The course was a triangular one, three miles to a leg. On the first and second legs Bob managed to keep ahead of Lon's boat; but on the third one, as the puffs were growing stronger with every blast, he began to lose his courage and let his sheet run every few minutes as the squalls struck his boat and knocked it down.

This was Lon's opportunity, and skilfully did he take advantage of it. Before they were half-way home on the last leg, the *Wanderer* was several lengths ahead of Bob's boat, and going like a steamer. Lon was soaked through with the spray.

Suddenly he again caught sight of Marion Darcy, who was coming out to meet the racing dories. She was to windward of the *Wanderer* when Lon saw her, and it made his heart jump

to see the way her cranky rowboat was "lying down" under the big sail. Although it was as much as he could do to hold the tiller in one hand and the sheet in the other, he took a turn of the sheet around the tiller for a moment, and with the hand left free waved to her to go back.

Whether she understood him or not, he did not know; but to his horror he saw her put the tiller up and start to run across the stern of his dory, with the sail of her boat broad off. Then just what he had feared happened. The boom rolled into the water, and as Marion jammed the tiller down to swing up into the wind, a vicious puff came tearing across the bay, caught the water-logged sail, and upset the boat, throwing Marion down into the sail.

Without a moment's hesitation, Lon jibed over and ran to where the girl was struggling to free herself from the sail and the sheet. He could see Bob Richards was keeping on his course, and he realized he had thrown away the race. But he never faltered for a moment. He knew Marion could swim, but he was afraid she would become tangled up in the sail. In that lay her danger.

True as the direction of the wind, he headed the *Wanderer* for the disabled boat and struggling girl. As soon as he came within hearing-distance he yelled, "Grab the boat!" and "Keep still!" and presently he had rounded the *Wanderer* up alongside of Marion's boat, from which it was comparatively easy to drag her into his dory. Then, while she laughed and talked excitedly, he made her sit down in the bottom of his boat, threw his oilskin coat around her shoulders, and after dropping his jib, proceeded to clear the mast and sail away from the overturned craft preparatory to towing it into the harbor.

Meanwhile the launch from the commodore's schooner had been tearing out to the scene of the accident. By the time Lon had Marion's boat ready, the launch was up with them, Commodore Black standing at the wheel in the bow. Just then, across the water came the sound of the gun announcing the finish. In the midst of the commodore's heartfelt expression of thanks, all Lon was thinking of was the fact that he had lost the prize. He refused to accept the offered tow, and beat back into the

Cove alone. He had to tell his mother of his failure to win the fifteen dollars.

It was the custom of the Yacht Club to end the day with a fireworks show, a supper, and the presentation of the prizes, and every one in

himself up in one of the windows at the back of the room with the other village boys.

Standing on the platform by the table, the handsome old commodore gave out the prizes, to the accompaniment of applause from the crowd in the parlor and out on the piazza. Lon felt a pang of jealousy toward Bob Richards when he saw him walk up the aisle to receive the little purse that contained three shining five-dollar gold pieces. Then the audience started to move out of the room, but the commodore raised his hand and asked every one to wait a moment.

He lifted from the table a red flannel bag, from which he drew another silver cup. Old yachtsmen and those near the table recognized at once the cup which the commodore's son (who had fallen in the Spanish War) had won in a hotly contested race nine years before.

"I have one more prize to present," he said. "It is an impromptu one, just as was the act it is to honor. This afternoon, most of us assembled here saw a boy do a very brave thing; he deliberately threw away a race he was about to

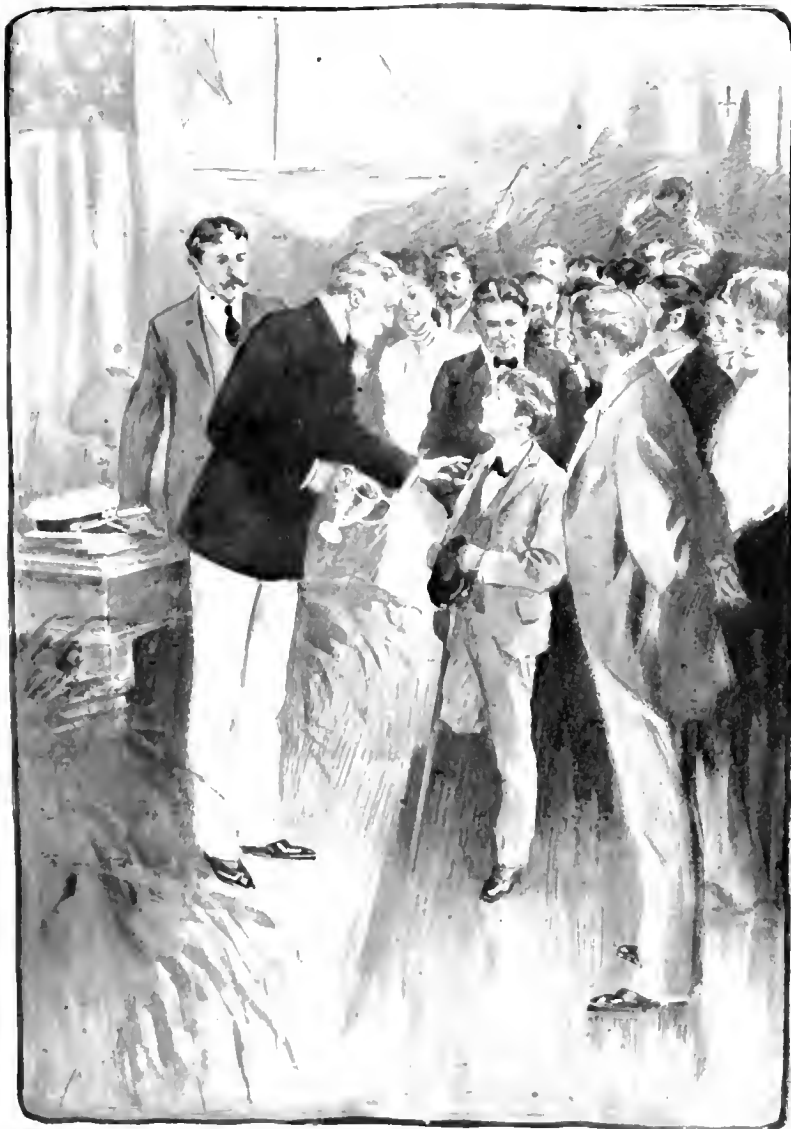

THE COMMODORE'S CUP. (SEE NEXT PAGE.)

the village attended the jollification. Although he had no share in the distribution of prizes, Lon stumped down to the club-house at eight o'clock. He was too whole-souled a boy to let his defeat interfere with the night's pleasure. The big parlor was crowded, and he had to perch

win in order to save a human life. You all know whom and what I mean—I refer to Alonzo Marshall, and his rescue of my niece." The commodore had to stop a moment until the clapping of hands and stamping of feet ceased. "In giving this cup, that was the prize of one brave

boy, to another brave boy, I feel that I am honoring both." Then he called out, "Come up here, Lon," and the red-faced lad was pushed lovingly by every hand that could reach him up through the narrow aisle to the platform.

As Lon took the cup, the kindly giver leaned down and whispered, "There 's something in-

side it for you, Lon." And while the crowd cheered and clapped and stamped their feet until the walls echoed again, Lon stumped away to show his prize to his mother. At the first electric light he stopped long enough to see what the "something inside" was; and his astonished gaze fell on a check for fifty dollars.



PINKEY PERKINS: JUST A BOY.

BY CAPTAIN HAROLD HAMMOND, U. S. A.

VII. HOW PINKEY SETTLED AN OLD SCORE.



FOR weeks Pinkey Perkins and his side-partner, Bunny Morris, had been waiting for a big frost, so they could go nutting. They had already gathered a few walnuts, which indelible fact was proudly evidenced in school by the prodigal display of hands covered with stains that "would n't come off till they wore off."

But the real excursion was to take place when they rode "Old Polly," the Perkinses' family mare, took their lunch, and stayed all day. Old Polly would carry single, double, quadruple, or sextuple, all depending on the ability of her passengers to remain aboard. The two boys were to ride her and also to carry home with them what nuts they might succeed in gathering.

Finally, one Saturday morning early in October, Pinkey awoke to find the ground covered with heavy white frost, and he knew the long-looked-for day had arrived. There had already been a few light frosts, but none like this one.

While Pinkey was eating his breakfast, Bunny appeared, armed with his lunch, done up in a paper, and with a flour-sack in which to bring home his share of the day's spoils.

It required a deal of maternal firmness to induce Pinkey to finish his meal, so desirous was he to be off. While his mother prepared his lunch, he and Bunny went to the stable after the horse, and little time was lost in getting under way.

Once started, Pinkey turned Old Polly's head southward, and, as soon as they were out of sight of the house, succeeded in urging her into a "lope," much to the discomfiture of Bunny, who was seated behind, holding a lunch-basket.

In planning their expedition, the two boys had consulted "Johnny" Gordon, son of Farmer Gordon, who lived about a mile and a half

south of town. Johnny had generously informed them that they could get all the hickory-nuts they wanted if they came out to his grove. He said the trees were full, and they might as well have some of them as not.

"But you 'll have to look out for paw," he warned; "'cause if he catches you in there, he 'll tan you, sure!"

Farmer Gordon, popularly known as "Old Hostetters," was conceded to be the "meanest man in seven States," being one of those small-souled individuals who seem to cherish a grudge against mankind. He was not a poor man by any means, but so tenaciously did he hold on to his money that his appearance and his continual references to his poverty would lead one who did not know him to believe him in dire need of the necessities of life.

Notwithstanding these well-known traits, Pinkey and Bunny decided to accept Johnny's offer and run the risk of encountering Old Hostetters in their endeavor to procure part of their winter's supply of nuts from his grove. In case they were successful, they would feel doubly repaid, and their pleasure would be all the more acute when they told the other boys where they had got the nuts.

Pinkey was too much of a strategist to lay his course to the grove in a direct line, for that would take them within sight of Farmer Gordon's house, and, besides, he might be coming to town about this time, and his suspicions would probably be aroused if he saw them and their flour-sacks going toward his farm. When they had reached a cross-road, about a quarter of a mile from their destination, Pinkey turned old Polly to the right, and then by a circuitous route they made their approach from the rear. After letting down some bars and opening a couple of gates, they arrived at the fence which inclosed Farmer Gordon's grove. There were

nuts a-plenty, and they lost no time in getting to work. They finally succeeded in climbing a tree, and soon the frost-bitten nuts were showering to the ground.

Like beavers they worked, climbing tree after tree, until by noon the ground was covered with the result of their labors. Their hands were bruised and their clothes were torn, but it mattered not. They had something to show for it all.

After caring for the horse and eating their own lunch, they began to "hull." They feared they had so many nuts that their flour-sacks would not hold them all. But by the time they had gathered and hulled all that were on the



"THE TWO BOYS HAD CONSULTED JOHNNY GORDON"

ground, they found that there were, by far, more hulls than nuts, and they lacked about a fourth of a sackful to make the day a complete success.

So again, tired and sore as they were, they both ascended a large hickory-tree and began to shake.

Suddenly they stopped, and exchanged glances.

"What 's that?" said Pinkey.

"Dog barkin'!" replied Bunny. "Let 's git."

"Where is he — can you see him?"

"No, I can't, but I 'm sure he 's a-comin' this way; his bark is gettin' louder every second."

It was plain that both boys were becoming very uneasy.

"Let 's keep right still," said Pinkey, "and maybe he 'll go on by. Hope there 's nobody with him, 'cause if Old Hostetters caught us in here, he 'd whale us well, most likely."

"Johnny said we could get all we wanted," argued Bunny, weakly. But both remembered that Johnny had warned them.

"Yes, but Johnny 's not Old Hostetters — not by a long shot," said Pinkey; "and like as not he 'd whale Johnny, too, for tellin' us."

By this time it was too late to come down, had they decided to do so. The dog was under the tree, nosing around the two sacks and the remnants of lunch. Presently he discovered the two boys in the tree, and again began to bark. Old Hostetters was not far behind. He had been making a visit to the town and was taking a short cut home through the fields.

"Treed 'em, did ye, Tige?" he said, as a malicious grin overspread his face: "bully fer you! We 'll teach these here town kids to steal nuts, won't we, Tige? How do you like yer roost, eh?" This last to Pinkey and Bunny.

Both were too scared to reply, and there was nothing to say, anyway.

"Don't think much uv it, eh.—purty rough settin' ye 'll find it 'fore mornin'."

They would not tell on Johnny. It would only get him in trouble, and would do them no good, so they kept mum.

"Hello! two sacks uv 'em, 'n' hulled too. Good thing we happened along, Tige," said Old Hostetters, as he discovered the sacks of nuts. "I c'n git six bits fer 'em up town."

"We gathered and hulled all them, 'n' they 're ours," shouted Pinkey, with growing courage as he saw Old Hostetters preparing to make off with the sacks.

"They are, are they? Well, we 'll see about that, young man. This 'll be the last time *you* 'll ever steal nuts in this grove." Old Hostetters called to his dog. "Here, Tige, you watch 'em while I tote these nuts to the house. We 'll show 'em how to rob a poor farmer, the young scamps. Watch 'em, Tige!"

Old Hostetters, being too lazy to carry the nuts himself, brought his old blind mare into service. She was grazing near by, which fact

was evidenced by the "tonk-a-tonk" of a cow-bell attached to her neck as a guard against her getting lost beyond an easy finding.

But Tige had not forgotten them. Old Hostetters had said, "Watch 'em," and "watch 'em" he did. He settled himself comfortably under the tree, his head between his paws, and occasionally rolled his eyes upward, just to make sure his prey had not escaped him. The two boys fell to discussing what would happen to them when Old Hostetters returned, and whether it would be better to risk Tige then or both of them later. Finally they decided to wait. An hour passed, and Tige still retained his attitude of vigilant comfort, while Pinkey and Bunny sat in the tree, cramped and helpless, and boiling with rage.

There is no telling how long this situation would have continued, had not a providential rabbit wandered within range of Tige's vision and tested his constancy. The temptation was too much for him, and he immediately deserted his uninteresting charges for the excitement of the chase, during which the two prisoners half slid, half fell to the ground and made their escape.

It was a dejected, heartbroken pair that dismounted at the Perkinses' stable that evening. When they parted, they entered into a solemn compact to "have revenge on Old Hostetters if it took ten years to get it."

Winter and spring came and went, and with the warm days of summer the annual epidemic of the swimming-fever broke

out among the boys. No matter what the consequence might be, a shrill whistle, accompanied by the mystic sign of two fingers held high in the air, was sufficient to cause any boy within hailing-distance to be seized by a violent attack of the disease. Nothing short of



"PINKEY AND BUNNY SAW OLD HOSTETTERS LOAD THEIR TWO SACKS OF NUTS ON THE OLD MARE'S PACK."

Helpless in their rage, Pinkey and Bunny saw Old Hostetters exultingly load their two sacks of nuts on the old mare's back and lead her limping and clanking away to the house. He paid no attention to them when he left. Apparently he had forgotten all about them.

an hour in the water, coupled with violent exercise, could bring relief and restore him to the full enjoyment of health.

One Saturday morning, Pinkey received some very definite and special instructions regarding some Sunday wood. These instructions must be carried out before he could go swimming. On school-days the boys all went swimming in the small ponds near the town, but on Saturday, there was a juvenile exodus to Crane Creek, about two miles south. There they had water deep enough to dive in, and a spring-board, from which the older ones turned somersaults into the water.

After sawing and piling what, in his estimation, was an economic sufficiency of wood, and without waiting for his estimate to be verified, Pinkey quietly departed by way of the back fence, and headed cross lots for Crane Creek.

As he got within sight of Farmer Gordon's hickory-grove his nutting experience came back vividly to his mind, and he burned for revenge. As a rule, Pinkey's grudges were short-lived, but the memory of the outrage he had suffered that day still rankled in his bosom.

As he passed the grove he noticed, about a hundred yards from the fence, a large pile of freshly dug earth. He saw a man bending over the mouth of a new well, from which he was drawing a bucket of mud and dirt. After emptying the bucket he lowered it again into the well. Then, after a few words to some one in the well, he picked up a small tin pail and started toward the house, obviously to get some drinking-water.

By intuition Pinkey felt that Old Hostetters

was in that well, the truth of which feeling he verified by creeping up to the well and looking in. There was Old Hostetters, twenty feet below, filling the bucket with soft, muddy clay. He had long needed a well in his pasture, and not being a man who would willingly pay out



"PINKEY FINALLY STOPPED WALKING AND FAINTLY TINKLED THE BELL AS A HORSE WOULD WHEN STANDING ALMOST STILL."

a dollar that he could save, he was doing most of the work himself, employing only a helper to hoist the dirt from the well.

To Pinkey this seemed a most opportune time to settle old scores. He wished for a bucket of water, that he might drench him. He could drop something on him, but that might

hurt him. Pinkey did not crave bodily injury as a revenge. But he could not let this chance slip. Here was Old Hostetters in the well, and the ladder he used in entering and leaving it lying on the ground outside. He thought of stealing the ladder, but it was too heavy; and, besides, the helper could get Old Hostetters out if he did take it.

Suddenly a brilliant thought flashed through his mind. He had hit upon a scheme that could not fail, and he lost no time in carrying it into effect.

Keeping clear of the well, he stealthily approached the old blind mare, who was quietly grazing in the corner of the pasture, and removed her bell. Then, slowly ringing it, in an aimless, halting sort of way, he indirectly approached the well. In this way he was able to imitate perfectly the noise made by the deliberate browsing of the old mare.

While yet several yards from the well, Pinkey heard a muffled, "Whoa! Whoa, there, *Kate!* Whoa, *BACK!!! KATE!!!*" come from the depths of the well.

Pinkey finally stopped walking and faintly tinkled the bell as a horse would when standing almost still. After remaining quiet for a minute, he again began his grazing "tonk-a-tonk," still gradually approaching the well.

Again, to his unspeakable delight, he heard, "Whoa! Whoa, there!! *Gee! GEE!! GEE!!! YOU old FOOL! HELP! HELP!!! WHOA, BACK!!!*"

Again Pinkey stopped. He was almost moved to compassion by the piteous wails of the helpless and frantic Hostetters. Then the vision of an old mare, with two sacks of nuts on her back, led by this same Hostetters, and clanking this same bell, came to his mind, and he remained firm. He was only human, and he must have satisfaction.

At the first clank of the bell, as Pinkey, for the third time, took up his deliberate, zig-zag approach, Old Hostetters fairly shrieked, "*WHOA, THERE! YOU OLD FOOL!!!*"

Whoa, *ZIM!* Whoa, *HE-A-W U-P!!! BACK! BACK!!* Whoa, *BACK!!!* Whoa, now! Stand still! *HELP! JIM!! ZIM!!!*"

Pinkey was now quite close to the well, and, just to heighten the reality, he kicked a few dry clods into the well. These brought forth only agonized groans from Old Hostetters, who was by this time so nearly petrified with fright that he could not articulate distinctly.

Suddenly, as a shower of clods came down on him, he gave one heartrending yell: "*ZIM! ZIM!! RUN! SHE'S A-FALLIN' ZV ON ME!!!*" Jim was his helper. Then, as a possible refuge from the equine avalanche which he felt every instant must be impending, he began with all his strength to dig a niche in the wall of the well.

As Pinkey looked toward the house he saw Jim sauntering along, carrying a pail of water. He decided it was high time for him to vacate the premises. As a parting shot he went to the mouth of the well, once more deluged the terrorized Hostetters with dirt and clods, let go the bell, and ran for the fence. As it clattered against the sides of the well and fell harmlessly to the bottom, a shriek came from the well that was music to Pinkey's ears.

When Jim reached the well he found a very abusive and irate man therein, promising Jim more different kinds of death than the proverbial cat could endure.

Jim proved his innocence by producing the bucket of water. He was as much at loss as to the identity of Old Hostetters's strange visitor as was that worthy himself.

Pinkey did not go swimming that day, nor for many days, at Crane Creek. Thereafter he confined his rural expeditions to the other points of the compass.

Before telling even Bunny of his escapade, he swore him to secrecy by all the solemn rites known to boyhood. A wholesome fear of Old Hostetters kept them almost suspiciously silent whenever that arch-enemy of mischievous boys was mentioned in their presence.

SCENES FROM THE GREAT WHEAT-FIELDS
OF CALIFORNIA.



A THIRTY "MULTI-POWER" COMBINED HARVESTER

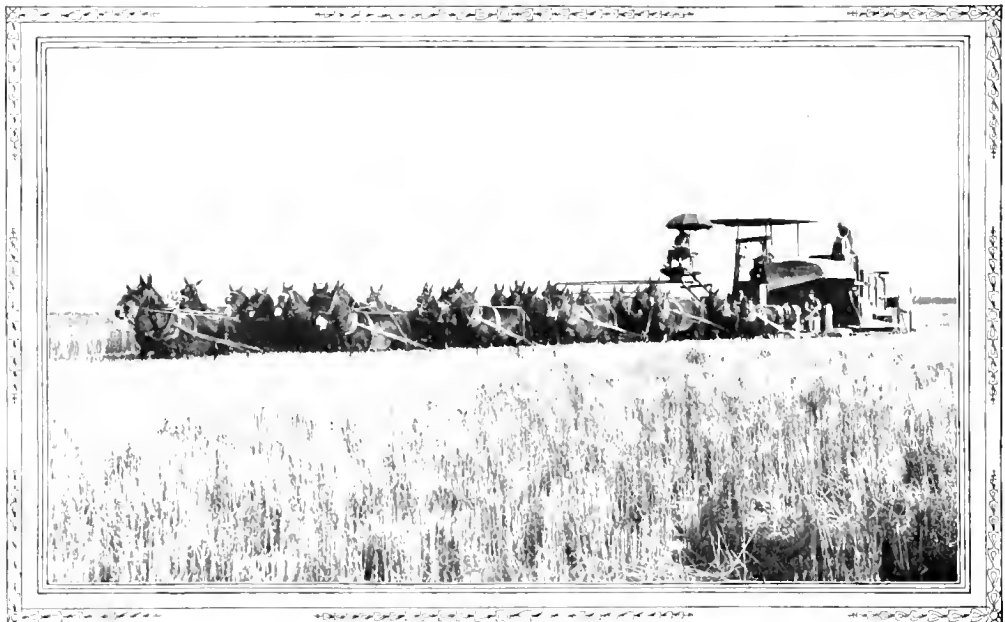

ANOTHER VIEW OF THE COMBINED HARVESTER.



A STEAM-POWER COMBINED HARVESTER.



ACRES OF WHEAT IN BAGS, TO BE TAKEN TO THE GRAIN-ELEVATOR.



AN AUGUST MORNING.

WHEN TO CRY.

THERE are millions of little boys and girls in the world who want to do just the right thing and the very best thing. But they do not always know what just the right thing is, and sometimes they cannot tell the very best thing from the very worst thing.

Now I have often thought that there are little boys and girls who cry, now and then, at the wrong time; and I have asked many of the older people, but none of them could tell me the best time to cry.

But the other day I met a man older and wiser than any of the rest. He was very old and very wise, and he told me:

"It is bad luck to cry on Monday.

"To cry on Tuesday makes red eyes.

"Crying on Wednesday is bad for children's heads and for the heads of older people.

"It is said that if a child begins to cry on Thursday, he or she will find it hard to stop.

"It is not best for children to cry on Friday. It makes them unhappy.

"Never cry Saturday. It is too busy a day.

"Tears shed on Sunday are salt and bitter.

"Children should on no account cry at night. The nights are for sleep.

"They may cry whenever else they please, but not at any of these times, unless it is for something very serious."

I wrote down the rules just as the old man gave them to me. Of course they will be of no use to the boys and girls who are past six, for those children do not cry. The wise old man meant them for the little ones—the millions of little boys and girls who want to do just the right thing and the very best thing.

Mary Elizabeth Stone.



A WELL-TAUGHT LESSON.

"I THINK my talk on Holland was impressive," teacher said,
 "For now each little maiden wears a windmill on her head."

Clara Odell Lyon.

THE BOY THAT BLOWS THE BUGLE.

BY JOSEPH B. GILDER.

I HARDLY KNOW, exactly, *just* what I'd like to be —
 A soldier in the army, or a sailor-boy at sea,
 I love the noise the drum makes, the horse the colonel rides,
 The flag the sergeant carries, and the soldiers' jerky strides.
 But when the tide turns seaward, and up the anchors come,
 I forget the flying banners and the bugle and the drum.
 O then I'd be a sailor, with rough and tarry hands,
 Bound out for Yokohama, or "India's coral strands."
 And yet, although I'm fairly brave, and not *afraid* to roam,
 I should n't like to find myself *too* far away from home.

So, if I get the chance, some day, I'll give the folks the slip,
 And get to be the bugler on a transatlantic ship.

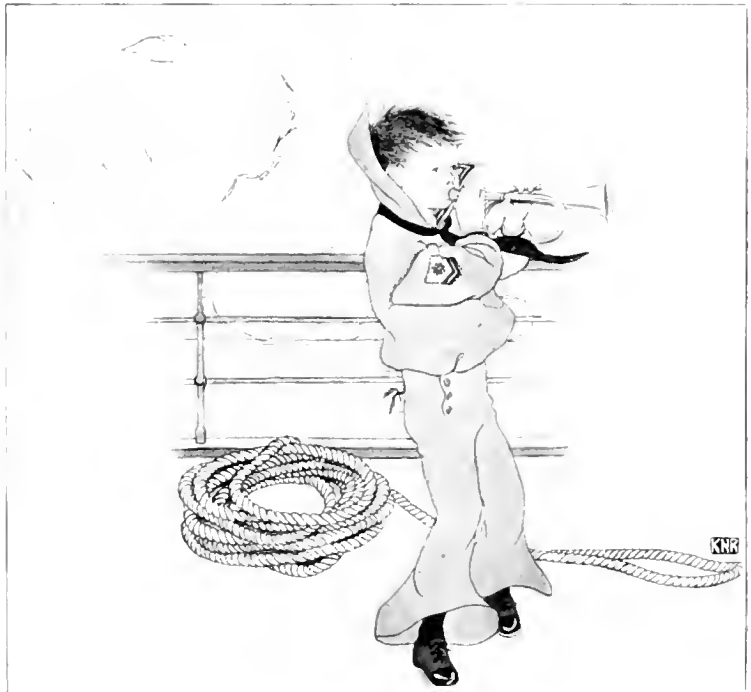

ON THE HILLSIDE.

F. G.



The place that I love best to go
Is up on the hill where the breezes
blow.

There are thousands of daisies and
buttercups there.

And the long, soft grass waves to and
fro.

I climb on top of the old stone wall
And watch the clouds in the bright
blue sky,

And the far-off road as it winds along,
And the ripples and waves from the
fields of rye.

And the brown-haired city girls, Bess
and Prue,

From the big house up where the
new lane ends.

They gather the daisies and call to me,
And are kind and jolly, and we 're
great friends.

They look so sweet in their pretty
gowns,

And I walk on the wall and watch
them play

Long games of golf, and they've prom-
ised me

That I shall caddy for them some day.

They like it, too, on the side of the
hill,

Where we look away over the fields
below,—

Oh, the place that I love the best of
all

Is up on the hill where the breezes
blow!

F. S. Gardiner.



ON THE HILLSIDE.

DRAWN BY FESSIE COLLINS PEASE.

QUEEN ZIXI OF IX.

Copyright, 1905, by L. FRANK BAUM.

BY L. FRANK BAUM.

Author of "The Wizard of Oz."

CHAPTER XIX.

THE BRAVERY OF AUNT RIVETTE.

THE Roly-Rogues were so busy rioting that they did not look into the air and discover Aunt Rivette flying over the city. So she alighted, all unobserved, upon a balcony of the palace, just outside the chamber of the Princess Fluff, and succeeded in entering the room.

drawer in which rested the magic cloak was still locked, and in a few moments the old woman had the precious garment in her hands.

It was, as we know, the imitation cloak Queen Zixi had made and exchanged for the real one; but so closely did it resemble the fairy cloak that Aunt Rivette had no idea she was carrying a useless garment back to her little niece and nephew. On the contrary, she



"HE MADE OLD JULYDUB, THE LORD HIGH COUNSELOR, ROOK HIM GENTLY AS HE LAY UPON HIS BACK." (SEE PAGE 884)

The creatures had ransacked this apartment, as they had every other part of the royal palace, and Fluff's pretty dresses and ornaments were strewn about in dreadful confusion. But the

thought to herself: "Now we can quickly dispose of these monstrous rogues and drive them back to their own country."

Hearing some one moving about in the next

room, she ran to the window and soon was flying away with the cloak to the place where she had left Bud and Fluff.

"Good!" cried the lord high steward, when

"But it would be an awful job to bury so many great balls," objected Bud. "It would keep all our people busy for a month, at least."

"Why not wish them dead and buried?"



"BUCKI WAS RATCHING THE BACK OF ANOTHER ROLY-ROGUE." (SEE PAGE '84.)

he saw the cloak. "Now we have nothing more to fear. Put on your cloak, your Majesty, and make the wish."

Bud threw the cloak over his shoulders.

"What shall I wish?" he asked.

"Let me see," answered Tallydab. "What we want is to get rid of these invaders. Wish them all in the kingdom of IX."

"Oh, no!" cried Fluff; "it would be wicked to injure Queen Zixi and her people. Let us wish the Roly-Rogues back where they came from."

"That would be folly!" said the dog Ruffles, with an accent of scorn. "For they could easily return again to our city of Nole, having once learned the way there."

"That is true," agreed Aunt Rivette. "The safest thing to do is to wish them all dead."

asked Ruffles. "Then they would be out of the way for good and all."

"A capital idea!" responded Tallydab.

"But I have n't seen these curious creatures yet," said Bud; "and if I now wish them all dead and buried, I shall never get a glimpse of one of them. So let's walk boldly into the city, and when they appear to interfere with us I'll make the wish and the Roly-Rogues will instantly disappear."

"That's all right," agreed Tallydab.

So the entire party returned to the city of Nole; Bud and Fluff riding their ponies, Aunt Rivette fluttering along beside them, and the lord high steward walking behind with his dog.

The Roly-Rogues were so much surprised to see this little party boldly entering the streets

of the city, and showing no particle of fear of them, that they at first made no offer to molest them.

Even when Bud roared with laughter at their queer appearance, and called them "mud-turtles" and "foot-balls," they did not resent the insults; for they had never heard of either a turtle or a foot-ball before.

When the party had reached the palace and the children had dismounted, Bud laughed yet louder; for the gigantic General Tollydob came to the kitchen door, wearing an apron while he polished a big dish-pan, the Roly-Rogues having made him a scullion.

The ruler of the Roly-Rogues was suffering from a toothache, so he had rolled himself into a ball and made old Tullydub, the lord high counselor, rock him gently as he lay upon his back, just as one would rock a baby's cradle.

Jikki was scratching the back of another Roly-Rogue with a sharp garden-rake, while Jikki's six servants stood in a solemn row at his back. They would do anything for Jikki, but they would not lift a finger to serve any one else; so the old valet had to do the scratching unaided.

These six young men had proved a great puzzle to the Roly-Rogues, for they found it impossible to touch them or injure them in any way; so, after several vain attempts to conquer them, they decided to leave Jikki's servants alone.

The lord high purse-bearer was waving a fan to keep the flies off two of the slumbering monsters; and the lord high executioner was feeding another Roly-Rogue with soup from a great ladle, the creature finding much amusement in being fed in this manner.

King Bud, feeling sure of making all his enemies disappear with a wish, found rare sport in watching his periwigged counselors thus serving their captors: so he laughed and made fun of them until the Roly-Rogue ruler stuck his head out and commanded the boy to run away.

"Why, you ugly rascal, I'm the King of No-land," replied Bud; "so you 'd better show me proper respect."

With that he picked up a good-sized pebble and threw it at the ruler. It struck him just

over his aching tooth, and with a roar of anger the Roly-Rogue bounded toward Bud and his party.

The assault was so sudden that they had much ado to scramble out of the way; and as soon as Bud could escape the rush of the huge ball, he turned squarely around and shouted:

"I wish every one of the Roly-Rogues dead and buried!"

Hearing this and seeing that the king wore the magic cloak, all the high counselors at once raised a joyful shout, and Fluff and Bud gazed upon the Roly-Rogues expectantly, thinking that of course they would disappear.

But Zixi's cloak had no magic powers whatever; and now dozens of the Roly-Rogues, aroused to anger, bounded toward Bud's little party.

I am sure the result would have been terrible had not Aunt Rivette suddenly come to the children's rescue. She threw one lean arm around Bud and the other around Fluff, and then, quickly fluttering her wings, she flew with them to the roof of the palace, which they reached in safety.

The lord high steward and his dog went down before the rush, and the next moment old Tallydub was crying loudly for mercy, while Ruffles limped away to a safe spot beneath a bench under an apple-tree, howling at every step and shouting angry epithets at the Roly-Rogues.

"I wonder what 's the matter with the cloak," gasped Bud. "The old thing 's a fraud; it did n't work."

"Something went wrong, that 's certain," replied Fluff. "You had n't wished before, had you?"

"No," said Bud.

"Perhaps," said Aunt Rivette, "the fairies have no power over these horrible creatures."

"That must be it, of course," said the princess. "But what shall we do now? Our country is entirely conquered by these monsters; so it is n't a safe place for us to stay in."

"I believe I can carry you anywhere you 'd like to go," said Aunt Rivette. "You're not so very heavy."

"Suppose we go to Queen Zixi, and ask her to protect us?" the princess suggested.

"That 's all right, if she does n't bear us a



"I'LL SOON CARRY YOU OVER THE MOUNTAIN AND THE RIVER
INTO THE KINGDOM OF IX."

grudge. You know we knocked out her whole army," remarked Bud.

"Quavo the minstrel says she is very beautiful, and kind to her people," said the girl.

"Well, there 's no one else we can trust," Bud answered gloomily; "so we may as well try Zixi. But if you drop either of us on the

gardens, shrubbery, and buildings were beautifully planned and cared for.

The splendid palace of the queen was in the center of a delightful park, with white marble walks leading up to the front door.

Aunt Rivette landed the children at the entrance to this royal park, and they walked slowly



THE LORD HIGH PURSE-BEARER WAS WAVING A FAN."

way, Aunt Rivette, I'll have to call in the lord high executioner."

"Never fear," replied the old woman. "If I drop you, you'll never know what has happened. So each one of you put an arm around my neck, and cling tight, and I'll soon carry you over the mountain and the river into the kingdom of Ix."

CHAPTER XX.

IN THE PALACE OF THE WITCH-QUEEN.

BUD and Fluff were surprised at the magnificence of the city of Ix. The witch-queen had reigned there so many centuries that she found plenty of time to carry out her ideas; and the

toward the palace, admiring the gleaming white statues, the fountains and flowers, as they went.

It was beginning to grow dusk, and the lights were gleaming in the palace windows when they reached it. Dozens of liveried servants were standing near the entrance, and some of these escorted the strangers with much courtesy to a reception-room. There a gray-haired master of ceremonies met them and asked in what way he might serve them.

This politeness almost took Bud's breath away, for he had considered Queen Zixi in the light of an enemy rather than a friend; but he decided not to sail under false colors, so he drew himself up in royal fashion, and answered:

"I am King Bud of Noland, and this is my sister, Princess Fluff, and my Aunt Rivette. My kingdom has been conquered by a horde of

bold a beautiful reflection in her mirror was both impossible and foolish; so she had driven the desire from her heart and devoted herself to ruling her kingdom wisely, as she had ruled before the idea of stealing the magic cloak had taken possession of her. And when her mind was in normal condition the witch-queen was very sweet and agreeable in disposition.

So Queen Zixi greeted Bud and his sister and aunt with great kindness, kissing Fluff affectionately upon her cheek and giving her own hand to Bud to kiss.

It is not strange that the children considered her the most beautiful person they had ever beheld; and to them she was as gentle as beautiful, listening with much interest to their tale of the invasion of the Roly-Rogues, and promising to assist them by every means in her power.

This made Bud somewhat ashamed of his



"THE LORD HIGH EXECUTIONER WAS FEEDING ANOTHER ROLY-ROGUE WITH SOUP FROM A GREAT LADLE."

monsters, and I have come to the Queen of IX to ask her assistance."

The master of ceremonies bowed low and said:

"I am sure Queen Zixi will be glad to assist your Majesty. Permit me to escort you to rooms, that you may prepare for an interview with her as soon as she can receive you."

So they were led to luxurious chambers, and were supplied with perfumed baths and clean raiment, which proved very refreshing after their tedious journey through the air.

It was now evening; and when they were ushered into the queen's reception-room the palace was brilliantly lighted.

Zixi, since her great disappointment in the lilac-grove, had decided that her longing to be-

past enmity; so he said bluntly: "I am sorry we defeated your army and made them run."

"Why, that was the only thing you could do, when I had invaded your dominion," answered Zixi. "I admit that you were in the right, and that I deserved my defeat."

"But why did you try to conquer us?" asked Fluff.

"Because I wanted to secure the magic cloak, of which I had heard so much," returned the queen, frankly.

"Oh!" said the girl.

"But, of course, you understand that if I had known the magic cloak could not grant any more wishes, I would not have been so eager to secure it," continued Zixi.

"No," said Bud; "the old thing won't work any more; and we nearly got captured by the Roly-Rogues before we found it out."

"Oh, have you the cloak again?" asked Zixi, with a look of astonishment.

"Yes, indeed," returned the princess; "it was locked up in my drawer, and Aunt Rivette managed to get it for me before the Roly-Rogues could find it."

"Locked in your drawer?" repeated the witch-queen, musingly. "Then, I am sorry to say, you have not the fairy cloak at all, but the imitation one."

"What do you mean?" asked Fluff, greatly surprised.

"Why, I must make a confession," said Zixi, with a laugh. "I tried many ways to steal your magic cloak. First, I came to Nole as 'Miss Trust.' Do you remember?"

"Oh, yes!" cried Fluff; "and I mistrusted you from the first."

"And then I sent my army to capture the

I've often wondered what became of my maid Adlena, and why she left me so suddenly and mysteriously."

"Well, she exchanged an imitation cloak for the one the fairies had given you," said Zixi, with a smile. "And then she ran away with the precious garment, leaving in your drawer a cloak that resembled the magic garment but had no magical charms whatever."

"How dreadful!" said Fluff.

"But it did me no good," went on the queen, sadly; "for when I made a wish the cloak could not grant it."

"Because it was stolen!" cried the girl, eagerly. "The fairy who gave it to me said that if the cloak was stolen it would never grant a wish to the thief."

"Oh," said Zixi, astonished, "I did not know that!"

"Of course not," Fluff replied, with a rather triumphant smile. "But if you had only come to me and told me frankly that you wanted to



"THE LORD HIGH STEWARD AND HIS DOG WENT DOWN BEFORE THE RUSH."

cloak. But, when both of these plans failed, I disguised myself as the girl Adlena."

"Adlena!" exclaimed the princess. "Why,

use the cloak, I would gladly have lent it to you, and then you could have had your wish."

"Well, well!" said Zixi, much provoked with

herself. "To think I have been so wicked all for nothing, when I might have succeeded without the least trouble had I frankly asked for what I wanted!"

"But — see here!" said Bud, beginning to understand the tangle of events; "I must have worn the imitation cloak when I made my wish, and that was the reason that my wish did n't come true."

"To be sure," rejoined Fluff. "And so it is nothing but the imitation cloak we have brought here with us."

"No wonder it would not destroy and bury

This expression of kindness and good will brought great joy to Zixi, and she seized the generous child in her arms and kissed her with real gratitude.

"We will start for the lilac-grove to-morrow morning," she exclaimed delightedly; and "before night both King Bud and I will have our wishes fulfilled!"

Then the witch-queen led them to her royal banquet-hall, where a most delightful dinner was served. And all the courtiers and officers of Zixi bowed low, first before the King of No-land and then before his sweet little sister, and



"'BECAUSE IT WAS STOLEN!' CRIED THE GIRL, EAGERLY."

the Roly-Rogues!" declared the boy, sulkily. "But if this is the imitation, where, then, is the real magic cloak?"

"Why, I believe I left it in the lilac-grove," replied Zixi.

"Then we must find it at once," said Bud; "for only by its aid can we get rid of those Roly-Rogues."

"And afterward I will gladly lend it to you also; I promise now to lend it to you," said Fluff, turning to the queen; "and your wish will be fulfilled, after all — whatever it may be."

promised them the friendship of the entire kingdom of IX.

Quavo the wandering minstrel chanced to be present that evening, and he sang a complimentary song about King Bud; and a wonderful song about the "Flying Lady," meaning Aunt Rivette; and a beautiful song about the lovely Princess Fluff.

So every one was happy and contented, as they all looked forward to the morrow to regain the magic cloak, and by its means to bring an end to all their worries.

The Quest Of A Nile-Green Collar.

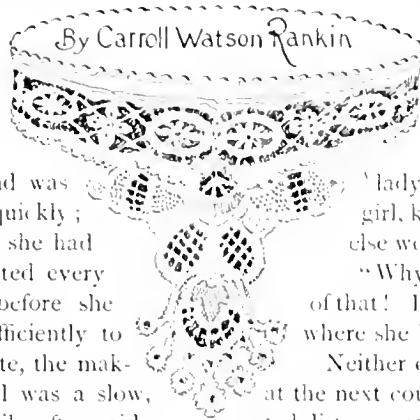

PERHAPS Katherine's mind was too large to be made up quickly; perhaps it was so small that she had to wait until she had collected every particle of all her brains before she could concentrate them sufficiently to form an opinion. At any rate, the making up of Katherine's mind was a slow, laborious process, as the family often said.

This was why the collar escaped in the first place. The girl was almost certain that it was the right shade; she almost knew that the price was more than reasonable; yet, because she was Katherine, and for no other reason that anybody could discover, she had hesitated. She herself was not lost, but the collar was; for a positive young person named Brown had decided at a glance that the collar was precisely what she wanted, had paid for it under deliberate Katherine's very nose, and had disappeared before the hesitating young shopper could utter a word of protest.

"But I wanted that collar!" objected Katherine, when it was too late for objections to avail. "Why, I've been here four times to look at it. It's the only one I've ever seen that would match my new green waist."

"I'm sorry," returned the shop-girl; "but really —"

"Oh, it was n't *your* fault. I should have been quicker. Are you sure you have n't another like it?"

"Quite sure," returned the girl. "You see, it was an imported article, and we had only one of each color. I could give it to you in yellow —"

"Oh, that would n't do at all. My waist is that peculiar shade of pale green that is so hard to match, and I have n't even a scrap of the goods left to make a collar. Dear me! Why was n't I quicker!"

"Perhaps you could buy it from the young

lady that got it," suggested the girl, kindly. "Perhaps something else would please her just as well."

"Why, I should never have thought of that! But I don't know her name nor where she lives."

Neither did the shop-girl; but the girl at the next counter, who had been an interested listener, stepped forward with the information that the name was Brown. More than this meager fact she was unable to impart.

Katherine consulted the city directory, discovered that the town contained twenty-two Browns, and likewise learned that there were Browns and Brownes. Then, with her amused mother's consent, she started on her unusual quest.

Like almost all slow persons, Katherine was persevering. She visited the twenty-two Browns in turn, but without finding the young woman who had purchased the collar. This pilgrimage, however, brought other, hitherto unsuspected Browns — also Brownes — to light. The Brainards possessed a visiting niece named Brown, the elderly Maynards had a Brown granddaughter, and one newly married lady stated that she had just turned from Brown to Grey.

"I believe," said this pretty little Mrs. Grey, when Katherine had laid the case before her, more than a week after the loss of the collar, "that the Armstrongs, who live just across the street, have a governess named Brown."

Katherine went to the Armstrongs' and asked for Miss Brown.

"She's gone," replied the maid; "but you could see Mrs. Armstrong."

Mrs. Armstrong listened kindly, and obligingly described her Miss Brown. The description tallied exactly with what Katherine remembered of the purchaser of the green collar. Miss Brown had even gone shopping on that particular morning for the express purpose of

purchasing neckwear; but, Mrs. Armstrong was sorry to say, the young woman had left her employ that same day to go abroad with the Poysers, who lived next door, and who expected to stay for two years, by which time, of course, the collar would be worn out and out of style.

"They were to sail," concluded Mrs. Armstrong, "this morning."

"Well," said Katherine, "that, of course, settles my collar."

Katherine was blessed with a great many relatives. Some of them admired, others were amused at, the persistence with which she sought for "Brown persons and green collars," as the family liked to put it. Every member of the large family connection was interested; and for nearly two weeks, trifle that it was, the Nile-green collar, and Katherine's enthusiastic search for Browns, became the principal topic at all family gatherings. When Katherine announced that the collar had gone abroad and was hopelessly lost as far as she was concerned, every member of the sympathetic family agreed that it was "too bad."

But the quest was not ended. Although Katherine herself had given up all hope of ever owning a collar that exactly matched the pretty waist, the family was more sanguine. Katherine's cousin Jessie went to a neighboring town to buy embroidery silks not obtainable in her own town, and saw a green collar. It looked to her very like Katherine's collarless waist, so generous Jessie promptly bought it. But it did not match.

Then Katherine's aunt Celandine, who had a pocketful of annual passes, went to Chicago to buy a shoe-string — at least Aunt Celandine's railroading husband claimed that a needed shoe-string was always a sufficient excuse. Arrived there, this wandering lady, unhampered by any lack of means, bought, with Katherine in mind, all the green collars she happened to run across in the course of a day's shopping.

Also, Katherine's married sister, a perennial victim of catalogue fever and likewise free from poverty, ordered green collars from almost every firm whose catalogue gave any indication that there might be green collars in stock; and several of Katherine's girl friends, unable to purchase ready-made collars, bought material that

purported to be Nile-green in color, and started to make a few.

But this was not all. Letters went from many of Katherine's kindly relatives — indeed, even Katherine herself wrote several — describing, sometimes with illustrations, the coveted collar. On one point they were unanimous. One and all implored the recipients to search the shops in their towns for Nile-green collars made of ribbed silk, edged with honiton, and provided with an elongated tab in front.

Even Katherine's granduncle William, who lived alone in Boston, heard about the collar, and, like the others, was instantly seized with a longing to send Katherine a green collar.

"Why," said the dear old man, folding the letter that told of the quest, "if there 's such a thing as a green collar in Boston, I 'll buy it for that nice little girl. I always liked the child."

Unfortunately, Granduncle William's kindness of heart greatly exceeded his knowledge of collars. If there is a dearth of green collars in Boston to-day, it is because a smiling old gentleman with soft, kindly eyes and a stately, courteous manner that pleasantly impressed the least considerate of shop-girls bought all the collars that could by any stretch of the imagination be called green. Fortunately for Uncle William's not-too-plethoric purse, a green collar is something of a rarity. Until one has actually searched for green collars, one cannot realize how little verdant neckwear even a town as big as Boston contains. Had the supply been unlimited, there is no knowing how far Uncle William's kindly zeal would have carried him. As it was, he was obliged to content himself with only sixteen, one for each year of Katherine's life. As no two of his purchases were alike, however, good Uncle William felt certain, as he expressed them to Katherine, that one of them at least would prove to be a replica of the ribbed-silk, long-tabbed Nile-green collar.

"I wish," said Katherine, some days later, "that somebody would pinch me. I believe I 'm asleep and dreaming green collars! For the last ten days every parcel I 've opened has contained anywhere from one to twenty-four green collars. Am I having a prolonged attack of nightmare?"

"You are not," returned her mother, laugh-

ing. "You are really having green collars. But is n't that a new parcel? Where did it come from?"

"The expressman just brought it — it's from dear, lovely old Uncle William. But — mother! Of all impossible collars! Every shade of green,

It was true. The waist was a tender Nile-green, a singularly elusive shade. The collars were bottle-green, olive-green, apple-green, grass-green, Irish-green, hunter's-green, sap-green, sage-green, Hooker's-green, Lincoln-green, emerald-green, and every other green

that nature or man has devised; but not one of them was wearable with the green waist.

"Collars, collars everywhere," paraphrased Katherine, as she viewed the collection on her bed and on the floor, with the shades graduated from light to dark; "and not a one to wear. Unless I have a 'Green-collar Sale' for the benefit of the Deans, or dye part of them black, or buy a waist to go with each one, I don't know what I'll ever do with them. I hope I sha'n't get any more."

But she did. About two months later the postman handed her an envelop addressed in an unfamiliar handwriting and bearing a foreign stamp. It contained a brief note and the very Nile-green collar that she had so much wanted to buy. The note read:



"'COLLARS, COLLARS EVERYWHERE', AND NOT A ONE TO WEAR.'"

every shape and every size that you can imagine. Sixteen of them!"

"How many does that make?" asked smiling Mrs. Dean, inspecting the contents of the latest box.

"Eighty-three," laughed Katherine; "and not a single one matches that waist!"

MY DEAR MISS DIAN: Mrs. Armstrong writes me that you were disappointed at losing a certain green collar that matched your waist, and that I inadvertently deprived you of it. Since it does not match mine, I have never even put it on, and so you must let me have the great pleasure of restoring it to you.

Truly yours,

ADLAIDE BROWN.

VALOR.

BY LUCY FITCH PERKINS.

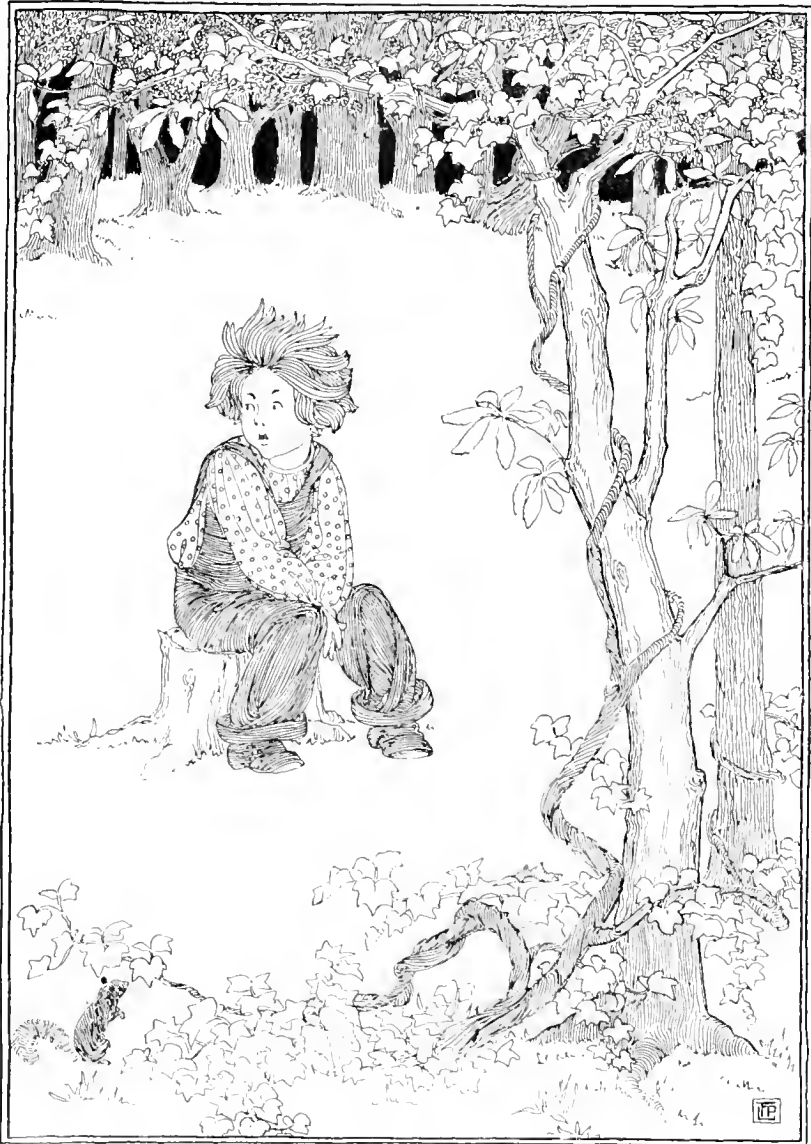

THERE is n't any giant
Within this forest grim,
And if there were, I would n't be
A bit afraid of him!



COURT NEWS.

BY LUCY FITCH PERKINS.



THE king and queen went out to-day,
A-riding on a load of hay.
The king fell off and lost his crown;
The queen fell, too, and tore her gown.



EDGAR'S "SISSY" JOB THAT PAID.

BY LOUISE J. STRONG.

MRS. PEARSON came down with pale face and tired eyes. Baby Rex was teething, and restless and fretful, and her sleep had been broken and unrefreshing. She glanced anxiously at the clock and about the untidy kitchen. The table was not set; a skillet of potatoes scorched on the stove, sending up a cloud of unsavory smoke; Frank was slicing bread; Edgar was putting the dry oatmeal in the dry boiler, and the dry tea-kettle snapped on a hot lid; Father Pearson fidgeted about, clumsily attempting several things.

"I asked you to fill the tea-kettle, Frank," he said, as Mrs. Pearson, having set off the skillet, took the tea-kettle and hastened to the sink.

"I forgot; and now there 's no water for coffee again, or oatmeal either!" Frank exclaimed. "Edgar, I thought you —"

"And I thought you would; I don't see what you want to cut bread the first thing for, anyway," Edgar retorted.

"Don't wrangle, boys," Mr. Pearson interposed mildly, adding, "Just give us anything, mother, so we can be off."

"I 'll do the best I can, but the boys have burned the potatoes, and there 's no time for coffee and oatmeal," she replied unsteadily, with discouragement in her voice. After a brisk quarter of an hour she reduced the chaos to a semblance of order, and produced something that passed for breakfast, which was eaten hurriedly, in a gloomy silence.

"You 've got to have help, some way, mother," Mr. Pearson said as he arose from the unsatisfactory meal. "I don't see how we can go on like this; and yet, until the outlook is better —"

"No," she interrupted, "you know we 've gone over it and over it! There 's not a cent to spare from absolute necessities: you can't risk a failure when times are so hard. We 'll get on better when baby is well." She tried to speak bravely, but was stifling a nervous sob.

"We cannot sacrifice you; we must find some other way." He hurried away, with anxiety added to his already heavy burden.

The younger boys, late now for school, clattered about getting ready, with Edgar's assistance.

"Mother," he said, when they were off, "I might stay at home and help you."

"No, dear, you must not miss your lessons," she replied, thanking him with a kiss.

There were six boys in the Pearson family — or five boys and the baby, as they put it.

"All wood-choppers; not a dish-washer among them," Father Pearson remarked sometimes, a little regretfully it must be admitted.



"EDGAR AND FRANK TALKED IT OVER THAT NIGHT IN THEIR ROOM."

With the care of baby, and looking after the clothing and comfort of the entire family, Mrs. Pearson had enough to do when the kitchen work and cooking were done for her; but now — Edgar the thoughtful shook his head.

He had noticed how worn the dear mother was growing, and understood his father's anxiety; he pondered the situation earnestly, and he and his older brother Frank talked it over that night in their room before going to bed. Frank had found Edgar reading when he came up to bed, and he tried to bring his brother to his way of thinking—that one of the younger boys should help their mother more. Edgar listened to him for a while, and then replied: "No, Frank, I have made up my mind. We can't go on like this, as father says; there 's a job right here, waiting for somebody, and somebody 's got to do it. You are father's right-hand man in the store; Archie 's too young, and, besides, he hates it like poison; Willie and Ted don't count for much, only at the table. That settles it! I am the one to do it."

When he came home at noon the next day he brought a bundle of gingham bought from his private savings. "Could n't you cut me a couple of long-sleeved aprons, mother, and run them up on the machine this evening?" he said, as he displayed the goods.

"Aprons!" cried Ted. "Are you goin' into a bakery?"

"Yes; the home bakery," Edgar replied. "You see," he explained, seating himself at the table, "mother 's got to have regular help. What 's everybody's business is nobody's business; we 've proved that. Under the present system we all do a little, and none of us does much. Now I 'm going to make the kitchen work my own particular business, mother being my general-in-chief. I 'll do all the cooking as fast as I learn how, and all the dish-washing."

"Hired girl! Sissy!" exclaimed Ted and Willie together, laughing.

"That 's it," Edgar said good-humoredly. "We certainly need a sissy bad enough in this family."

"So we do. But it is n't an easy place to fill, and I 'm afraid you 'll make a poor substitute," commented his father.

"Wait a while and you 'll change your mind, father. I 'm in earnest, and I mean to study cooking as I hope to study law some day."

"But you must n't leave school, my dear," his mother said.

"No, mother, I don't intend to. You 'll all

have to be ready for breakfast a half-hour earlier, so I can get my work done. Some girls do lots of work and go to school. Mary Beach works for her board, and I asked her all about it. She accomplishes a great deal, but I think I can do as well, or better, when I learn how. A boy past sixteen ought to be as smart as a girl the same age."

"The boys 'll make sport of you for doing girls' work," Archie reminded him.

"Of course! I expect that! Guess I can stand it. We 've all got to eat yet awhile, whatever we do in the future, and it 's a good thing for a fellow to know how to cook, sometimes. Don't you remember how Uncle Joe said he wished he could cook when he was in the army? Now, then, I 'll wash these dishes in a jiffy, while mother puts Remy to sleep."

He took up the work with a cheerful, willing earnestness, and his mother's face brightened with an expression of relief as she watched and guided him, and the plan began to look feasible.

"But it won't last. Our Biddy will strike after a few weeks of it," Frank prophesied one day. "And won't the crockery suffer!"

"Wait and see," Edgar replied.

Day after day he tramped about the kitchen like a warrior, conquering the difficulties that arose, with a persistent patience and a comforting cheerfulness. His mother often smiled to hear his merry whistle or boyish roundelay, to the accompaniment of rattling pans and kettles. He developed a deft quickness, and the crockery suffered no more than the usual accidents.

From the first he was not at all ashamed of his "job," and answered the door-bell, if his mother was not in the house, in his apron if necessary. Once, so garbed, he conducted the minister into the parlor, blushing under the good man's warmly expressed approbation.

Of course when the boys got hold of it they set upon him.

"Gone into the Biddy business, I hear," Ralph Cone teased.

"Yep." Edgar smiled on the crowd of boys.

"Ho, ho! sloshing in the dish-water like a girl," jeered Bob.

"No, I slosh like a boy, and I 'm having more fun than you could shake a stick at," Edgar laughed, and he thought of "Tom Sawyer."

"Fun!" That *was* news.

"Yep. You just ought to see me knock the spots out of the bread-dough. It 's great! Beats the punching-bag all to pieces. You see, I bake a whole lot at once, and have a pile of dough; I roll up my sleeves, scrub my fists till you would n't know them, and play I'm a prize-fighter, and cuff, and maul, and pound that dough in a way to make your eyes pop. It 's soft and does n't hurt your hands, and the more you beat it the better bread it makes. It 's great sport!"

It sounded like it, the way he told of it. Some



"EDGAR TOOK FROM HIS VEST-POCKET A DOUBLE SHEET OF LETTER-PAPER."

of the boys doubled their fists and thumped an imaginary dough-pile, wishing they could try the real thing.

"But it 's women's work, all the same, and nothing in it. You would n't catch me at it!" Tom Smith declared.

"Now look here." Edgar took from his vest-pocket a double sheet of letter-paper on which he had pasted a clipping from a newspaper, which he had ready for such an occasion. "Just

listen to what some men get for doing this kind of 'women's work.'" He read them a clipping of an account of the salaries paid to some of the great chefs.

"Wh-e-e-w!" whistled Ralph. "Thousands of dollars! What a lot just for cooking!"

"'Just for cooking,'" quoted Edgar. "Did you never think, son, how important cooking is, and eating, too? Tom has, I know," and they all laughed, for Tom could do wonders in the matter of eating.

"I don't know as I'm so much more given to eating than the rest of you," Tom protested, "unless it 's doughnuts. Say, do they let you make 'em, Ed?"

"I should say so! — by the peck! I can make dandy ones, too! Going to make a lot Saturday; if you fellows 'll come round about ten, I 'll let you sample 'em. But you 've got to stay on the back porch, for I scrub Saturday mornings, and I won't have you tracking the floor."

They were there, and watched enviously as he flourished about, magnifying his importance, and patronizingly distributing two cakes each, crisp and brown and fragrant, just from the kettle. They left with the impression that his was an enviable position, and spread abroad his skill as a cook; and his fame grew.

He kept at it all winter, learning readily because he put his mind to it, and doing the cooking to the satisfaction and content of the family, and with considerable pride in his own dexterity. His mother often declared that she would never get such another worker.

"I don't know that I 'd care to go into it as a life business, but while I'm getting ready for something else, this is good enough," he said at times.

Early one morning in June, soon after school had closed, a young man called at the Pearson home.

"I hear that you have a young fellow here who can cook. May I see him, please?" he asked.

Edgar came forward, aproned from chin to shoes. "I do a little in that line," he said.

"How much of a little? And are you open to an offer of a situation?"

"To go out cooking?" Edgar exclaimed, and his brothers at the table could not refrain from laughing. Even his mother smiled.

The stranger smiled, too, explaining: "A lot of our club fellows go up to the Lakes every summer; we have a camp there and a good outfit, but we find it difficult to get a reliable cook and caretaker. We come and go, and want some one trustworthy there all the time. You're younger than I expected, but you look dependable. What kind of cooking can you do?"

"Most of the plain and some of the frills,

time; no one was about the building but a cabman removing some baggage from the box-seat, and a perspiring iceman lazily crossing the street with the daily charge for the waiting-room ice-cooler. As Edgar drew nearer, however, Mr. Thompson came down the steps with his grip-sack and rods, and hailed his new cook. Together they went across the street and bought a few things at the hardware-store.

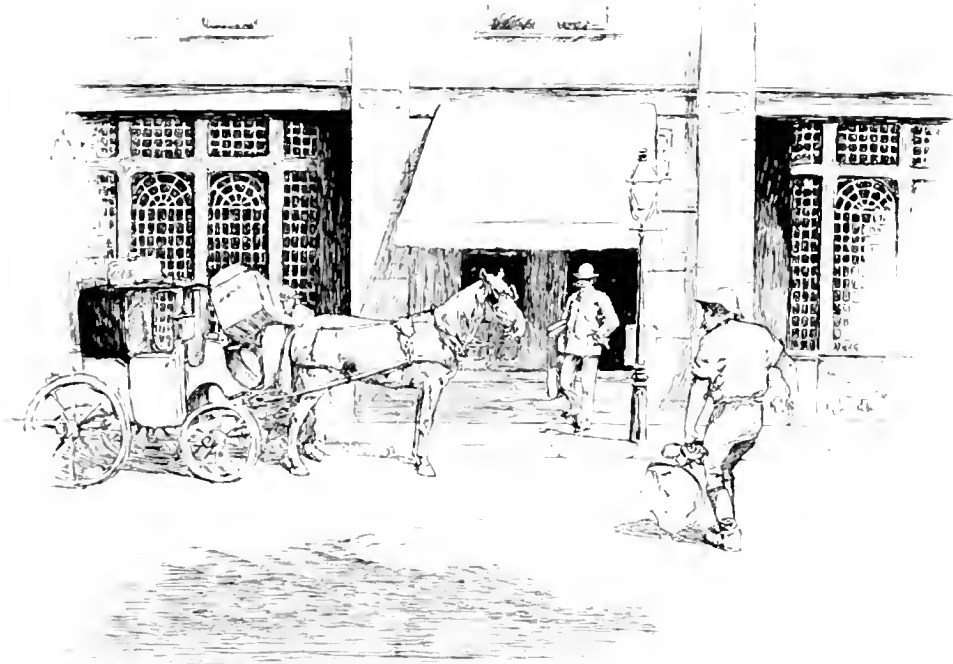

"MR. THOMPSON CAME DOWN THE STEPS WITH HIS GRIPSACK AND RODS."

like pie and gingercake, doughnuts and rice-pudding." Edgar hastily ran over the list of his accomplishments.

"You'll do; we never had a man who could cook as much. We give fifty dollars a month and expenses. We would want you next week, and probably until the last of September. What do you say?"

"I'll go, and cook my prettiest," Edgar replied excitedly.

"We'll call it settled, then," replied the visitor. "My name is Thompson, and I will be at the station to-morrow in time for the 12.30 afternoon train. Meet me there."

It was a hot June midday when Edgar arrived at the station. He was there ahead of

As the time approached for the departure of the train, Edgar's friends began to arrive, and soon it seemed that every boy he ever knew was there.

Edgar boarded the train, to an accompaniment of cheers from the boys. But he was saying to himself: "Three months at fifty dollars a month! I'll get rich! Mother shall have a good Bridget in my place. I see my way through college! I'll cook myself through! Hurrah! Hurrah!"

The boys saw him off with considerable envy.

"Just think of all the fun you're going to have, and get paid for it, too!" Ralph said.

"Why, boy," Edgar chaffed, "it's nothing but women's work — just a sissy dish-water job," and he waved his hat from the car window.

STORIES TOLD BY INDIANS.

BY THE LATE JULIAN RALPH.



A MOTLEY band of half-breeds and Chippewa Indians had camped at the first portage on the Nepigon River, north of Lake Superior. They were at work for the great

Hudson Bay Company, carrying supplies to a distant fort or trading-post in the north. It was a wild spot, but the game, large and small, seemed to know that it was "out of season," and that their pelts were of little value at that time. A family of bears not far from the camp frolicked and splashed in a shallow natural basin with all the glee that might have their captive relatives in the safe pits of a zoölogical garden.

Among the Indians was one far older than the others, a little, thin, bent old man, with a face as wrinkled as a nutmeg, with the complexion of the sole of one of your shoes, with his griz-

ple supper had been eaten, there was gathered in front of this queer little old man the Indian and half-breed boys, and all asking for a story. The old Chippewa smoked on gravely and reflected as we are led to believe Indians do most of the time. Soon he removed his pipe from his mouth and talked, as Indians like to do in the right place and time. It is not true that Indians are always silent; they often gabble like children when their interest is aroused.

Every boy who has read Grimm's fairy tales remembers the story of the master thief who stole the horse while a man was on his back. The Blackfeet Indians have such a story, and although it is a tale of the cleverness of their enemies, they nevertheless recite it to their children.

This is the story the old Indian told:

THE STORY OF THE GREAT WHITE HORSE.

ALL Indians who use horses are very fond of horse-racing, and not only race their own horses



"A FAMILY OF BEARS NOT FAR FROM THE CAMP FROLICKED AND SPLASHED IN A SHALLOW NATURAL BASIN."

zled hair cut off square around his neck, with not an ounce of flesh to spare, and dressed in moccasins, trousers, a red worsted belt, and a gray flannel shirt. One evening after the sim-

against one another, but they race their own against those of other tribes,—and used to do this even in the wild era of the buffalo and of constant warfare. Even at that time friendly

tribes and bands joined in the two grand buffalo hunts of each year, and, after the hunting was over, pitted the fastest horses of the various bands one against the other. At one time, not so very long ago, the Blackfeet had the very

Crows, the Sioux, the Crees, and all the other Indians of the plains.

Stealing is considered fair between tribes, and if it can be successfully done those savage people think it very honorable, even glorious.



"FROM THAT DAY HIS TRIBE OWNED THE GREAT WHITE HORSE." (SEE NEXT PAGE.)

fastest horse that any one knew of; the fastest horse of which any one could tell, or which any one had seen. He was a source of wealth to the tribe, for Indians are very fond of betting, and this animal always won everything that was bet against him. You can imagine how proud the Blackfeet were of this creature. You can also imagine how envious were the Stoneys, the

The Blackfeet, therefore, kept the wonderful race-horse in a tent at night. They did not dare leave him out with their other horses. They bought a string of bells at the Hudson Bay Company's nearest Fort, put the bells around the horse's neck, tied him to a tepee pole inside a big tepee, and set four men to sleep in the tent with him. This was the

rule every night, and on no night did the men forget to close the door of the tepee and "cinch" it tight with thongs of buckskin. Whoever could steal that big white beauty of a horse had to be a very clever thief, they thought; but, in truth, they never dreamed that he could be stolen.

The smartest thief among the Crow Indians told his chief and the head men that he was going to try to get that horse away from the Blackfeet. One evening he crawled through the grass to the tall bluff along the Bow River (north of our Idaho, I think, was the locality), where the Blackfeet had their camp. He saw the noble horse led into a certain tent, and he saw the four watchers go in and close the door. Night fell, and he crept down the slanting bluff into the camp. The only thing he had to fear was the barking of some dog. If a dog saw or heard him and barked, that would set all the other dogs barking and he would be obliged to run for his life. Stealthily, as only an Indian can move on his softly moccasined feet, this arch-thief of the thieving Crow nation crept into the Blackfoot camp. He had to step over several sleeping dogs, and he did not awaken one. He came to the tent of the white horse. He looked it all over. He went to another tepee and took a travois from its side and carried it and set it up against the horse's tent.

A travois is the wheelless wagon the Indians use in the summer. It is made of two long poles with the upper ends near together; the lower ends spread apart and drag upon the ground. You see by this description that if a travois is stood on end, it can be made to serve as a sort of ladder. Thus the arch-thief of the Crows used the one he put up against the horse-tent. On it he climbed to the top of the tepee, and from there he got a view of the interior, looking down between the tent-poles that form the sides of the chimney-hole. He saw the horse dimly, and even more dimly he saw the four men beside the horse, all asleep. He climbed upon the tent-poles; he poised his body very nicely in the chimney-opening; he dropped fairly and squarely upon the white horse's back!

The instant he felt himself on the back of

the beast, his knife, which was in his hand, swept through the cord that tethered the horse. His heels shot in against the horse's sides, the bells rang out sharp and clear, and the horse snorted with surprise. But the pressure of the thief's heels urged the animal forward, and as he took one step the man reached out and slit a gash straight up and down through the fastened door, which was only buckskin. The four Indians leaped to their feet, but the horse and his captor were now out in the open ground and like the wind shot away from the camp. The watchers ran and yelled, the dogs barked, the whole tribe rushed out of the tents, and every man sprang to horse! But what was the use? There was no horse that could catch the animal, and so they all turned sadly home again after a mad ride of a mile or two. The thief rode in triumph home to the tents of the Crows, and from that day his tribe owned the great white horse, and his fame and their riches increased.

The little redskins listened eagerly to this story, which, doubtless, they had often heard before; but they were not so quiet as the reader might imagine, for they asked so many questions that the old man pretended to be cross, and said that if they wanted to know so much he would not tell them another story.

THE STORY OF NAN-AB-BEJU.

"I WILL tell you the story of Nan-ab-beju," said the old fellow, relenting. "He is the man who made the new earth after the big water came and covered it."

He told this tale in the Chippewa tongue, and I can only repeat it as it was translated to me afterward. It will remind you, in parts, of the flood and Noah and the ark:

"Big waters came, and there was nothing anywhere except water, and the sky, and the sun, and the stars," said the old Chippewa. "Nan-ab-beju made a great raft, and put on it some relic of everything that had been on the earth: specimens of each kind of animals, of all the trees, shrubs, plants, flowers, birds, rocks,—and one man and one woman. In short, he did not leave out anything except

sand. He forgot to save some sand, and yet he could not do anything without it. He sailed out far into the flood and made a little island, very, very small. Then he found he had no sand. He made a very big line, longer than hundreds of deerskins cut up into ribbons and tied together, and he took a muskrat off the raft and tied the line to it, and threw it

"Nan-ab-beju blew his breath on the muskrat, and its life came back to it. Then he mixed the sand in the little island that he had made, and blew on that also. As he blew and blew, it swelled and swelled until it was so big that Nan-ab-beju could not see the sides or end of it in any direction. Nan-ab-beju was not quite certain whether he had made it as big as the old earth before the big water came. He had to make it as big as it had been; so big, in fact, that no man or creature could find the end of it. He had plenty of animals that could travel over the earth and find out how big it was, so

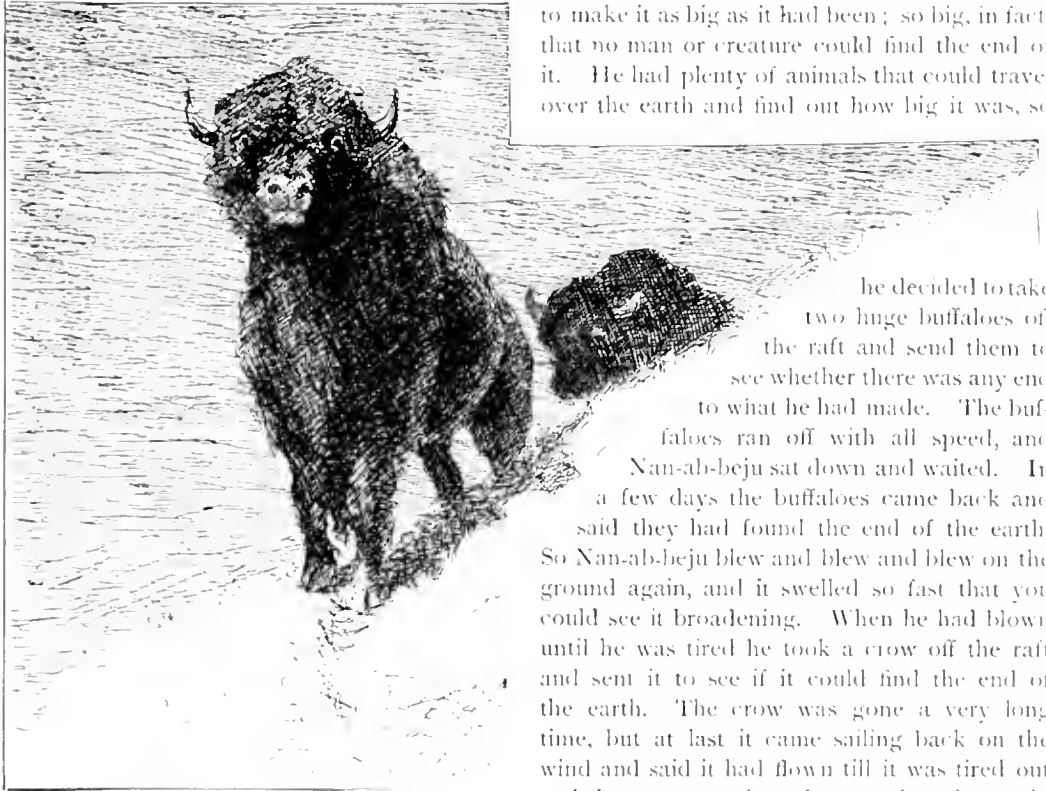

"IN A FEW DAYS THE BUFFALOES CAME BACK."

into the water. The frightened rat dove down and down, and when there was no longer any pulling at the line Nan-ab-beju knew the rat was at the bottom of the sea. Then he began to pull the line up. At the end of it came the poor muskrat, stone dead, drowned. But Nan-ab-beju saw that the little black paws of the animal were clenched as if there was something in their palms that the rat had held tight hold of even after death. The little paws were forced open, and in them were found half a dozen grains of sand. One grain would have been enough for the great Nan-ab-beju.

he decided to take two huge buffaloes off the raft and send them to see whether there was any end to what he had made. The buffaloes ran off with all speed, and Nan-ab-beju sat down and waited. In a few days the buffaloes came back and said they had found the end of the earth. So Nan-ab-beju blew and blew and blew on the ground again, and it swelled so fast that you could see it broadening. When he had blown until he was tired he took a crow off the raft and sent it to see if it could find the end of the earth. The crow was gone a very long time, but at last it came sailing back on the wind and said it had flown till it was tired out and there was no sign of any end to the earth.

"Nan-ab-beju, to make sure, blew again and swelled the earth a great deal bigger. Then he untied and uncaged and untrapped all the animals and drove them from the raft on to the land, and left them free to roam where they might. He took all the trees, plants, bushes, and shrubs, and planted them around; and he blew the grass out of his hands as hard as he could blow it, so that it scattered all over. Next he let loose all the birds and beetles and bugs and snakes and toads and butterflies; and, finally, he invited the man and woman, both Chippewas, to go ashore and make the new earth their hunting-ground. And Nan-ab-beju's task was done."

HOW TO STUDY PICTURES.

BY CHARLES H. CAFFIN.

A series of articles for the older girls and boys who read "St. Nicholas."

TENTH PAPER.

COMPARING BRETON WITH MILLET.

JULES BRETON (BORN 1827); JEAN FRANÇOIS MILLET (BORN 1814, DIED 1875).

HERE are two pictures of peasant subjects, and, as it happens, with very similar titles: Jules

ent. As the meek women stoop, one carries her left hand behind her back and the other's elbow is lifted backward. If you imitate for yourself the action of leaning down and extending one hand, you will find that the other has an in-



"THE GLEANERS" BY JEAN FRANÇOIS MILLET.

Breton's "The Gleaner," and "The Gleaners" by Jean François Millet.

With what a proud courage Breton's girl strides through the field! How painfully Millet's women are stooping! — their figures are clumsy, uncouthly clad, and you cannot see their faces. The girl, however, is dressed in a manner that sets off her powerful and supple form: her face is strong, and its expression haughtily independ-

ent. As the meek women stoop, one carries her left hand behind her back and the other's elbow is lifted backward. This natural tendency of the human body to secure its balance is a principle that the best artists rely upon to produce a perfect poise of rest or movement in their figures.

Now study the arms in Breton's picture. The left one — with what a gesture of elegant decision it is placed upon the hip! — while the right has the elbow thrown out with an

action of freedom and energy. Evidently the girl is not tired, or the elbow would seek support against the chest. Her hands, too, are finely shaped, and the fingers spread themselves rather daintily. I wonder if so light a grasp as that of the right hand on a few heads of wheat would really hold the sheaf in place upon her shoulder! I wonder, also, how her bare, shapely feet withstood the pricks of the stubble! I notice that Millet's women have prudently kept on their clumsy wooden sabots.

But now turn the inquiry toward your own experience. If you went into a wheat-field, where peasants were gleaning, would you expect to see a beautiful, proud girl like Breton's, unt fatigued by her toil, or homely women like Millet's? I fancy you would be more likely to meet the latter, and I doubt if anywhere in France you might come across such a type as Breton's, which is rather that of the women of the Roman Campagna, a noble remnant of the classic times. She is unquestionably a handsome creature.

But beauty does not consist only in what is pleasing to the eye; there is a beauty also which appeals to the mind. "Truth is beauty, and beauty is truth." Perhaps, if we study Millet's picture, we shall find that it has a beauty of its own in its truth to nature. His women are not posing for their picture. Quite unconscious of anybody's gaze, they are absorbed in their toil, doing simply what they are supposed to be doing in the most natural way. They are very poor, these peasants: working early and late, and, despite all their labor, keeping body and soul together with difficulty; a meek, God-fearing race, roughened and drawn out of shape by toil.

With what an intimate insight into the lives of these people as well as into their occupation Millet represents them! He paints them, not as if he were a city gentleman visiting the country,

but as if he belonged to their own class. And, as a fact, he did. He was the son of a small farmer, and had bent his own back under the scorching sun and felt the smell of the earth in



"THE GLEANER," BY JULES BRETON.

his nostrils. But an uncle, who was a priest, had taught him as a boy, so that in his manhood he read Shakspeare and Vergil in the original texts. Therefore, although he was of the peasant life, he was greater than it, and he brought to the interpretation of its most inti-

mate facts a largeness of view and depth of sympathy which make his pictures much more than studies of peasants. They are types. He painted a picture of a sower that is now in the Metropolitan Museum, New York; and when we have once grasped the fullness of its meaning, it becomes to us the type of the sower; so that we could not look on another picture of similar subject without instinctively comparing it in our mind with Millet's.

Breton, on the other hand, had never toiled in the fields; he pursued the usual routine of study through the art schools, whereas Millet, "wild man of the woods," as the other students called him, tried the usual methods only to abandon them. He could not master, or bring himself to care about, the elegancies and refinements of drawing as practised in the schools. In these Breton is proficient. He has also written very creditable poetry; so that, when he went into the fields for subjects, he had the teaching of the schools in mind and the sentiment of a poet in his heart. Accordingly, he freely translated the peasant into both.

Note, then, these two ways of reaching a poetical result: Breton had beautiful ideas, and used the peasant as a peg on which to hang them; Millet, with no direct thought of being poetical, sought only to portray the truth as he saw and felt it. But he has represented the dull, homely facts with such an insight into the relation which they bear to the lives of the people engaged in them, that he has created — and this is the great accomplishment of the poet — an atmosphere of imagination around the facts.

In our era Millet's method has prevailed both in literature and in painting. The present is an age of what has been called naturalism, and one of the master minds who helped to make it so was Millet.

His early life was very close to nature. His father's farm was at Gruchy, in the hilly department of Manche, which juts out like a promontory into the English Channel. In that narrow strip the sea is nowhere far off. He grew up in the air of the hills and of the sea — surroundings bringing sturdiness of character and development of imagination, if a boy chance to have either of these. And the young Millet

had. He knew nothing of art or artists, but he had the desire to represent what he saw, and in the interims of work upon the farm he would copy the engravings in the family Bible, or take a piece of charcoal and draw upon a white wall. By the time he was eighteen a family council was held, and it was decided that the father should take him to Cherbourg and consult a local painter as to Jean's prospects. The painter advised his studying art and undertook to teach him. However, he worked in Cherbourg only two months, for then his father died and he had to return home to resume his work as a farm laborer. Three more years he labored, until the municipality of Cherbourg provided a sum of money to enable him to go to Paris to study. He was now twenty-three, a broad-chested Hercules, awkward and shy, his big head covered with long fair hair, with nothing to denote intellectual force except a pair of piercing dark-blue eyes. Delaroche, to whose studio he attached himself, was kind to him; but Millet could not understand the large classical pictures that the master painted. To him they seemed artificial, with no real sentiment. Ringing in his ears, even then, as he used to say in later life, was the "cry of the soil," — memories of his home life, that in some way he wanted to learn to paint. Delaroche's studio was no place for him, and after a little while he left it.

Then followed eight years of beating the air. He married and had to bestir himself for a living; he tried to paint what the people seemed to like — pretty little figure subjects; but prettiness was not in his line, and the attempt to seek it disgusted him. Suddenly he made the great resolve to paint what he wished to, and could, paint, and in 1848 produced "The Winner." It represented a clumsy peasant, in uncouth working-clothes, stooping over a sieve as he shakes it to and fro. From the point of view of the academies, a shockingly vulgar picture! Yet it sold for five hundred francs (\$100). Millet now had the courage of his convictions.

His friend Jacque, afterward the celebrated painter and etcher of sheep and poultry, told him of a little place with a name ending in "zon," near the forest of Fontainebleau, where

they could live cheaply and study from nature. The two painters, with their wives and children, rumbled out of Paris in a cart which took them to the town of Fontainebleau. Thence they proceeded on foot through the forest. It was very wild in those days. "How beautiful!" was Millet's constant exclamation. Arrived at Barbizon, they were welcomed at Ganne's Inn by Rousseau, Diaz, and the other artists who lived in the village, and invited to the evening meal. When a fresh painter came into the colony it was the custom to take down from the wall a certain big pipe, that, as the newcomer puffed at it, the company might judge from the rings of smoke whether he was to be reckoned among the "Academics" or the "colorists." Jacque was proclaimed a colorist; but, some uncertainty being expressed concerning Millet, the latter exclaimed, "Ah, well, if you are embarrassed, put me in a class of my own." "A good answer," cried Diaz; "and he looks strong and big enough to hold his own in it." The little pleasantry was prophetic.

But its fulfilment was deferred for many years, during which Millet worked on in poverty; pictures that now would bring large sums of money being refused at the exhibitions of the Salon and finding no purchasers. A hint of his condition is contained in a letter to his friend Sensier, acknowledging the receipt of twenty dollars: "I have received the hundred francs. They came just at the right time. Neither my wife nor I had tasted food for twenty-four hours. It is a blessing that the little ones, at any rate, have not been in want."

It was only from about his fortieth year that his pictures began to sell at the rate of from two hundred and fifty to three hundred francs each. Rousseau, who had himself known the extremes of poverty, was the first to give him a large sum, buying "The Wood-cutter" for four thousand francs, under the pretense that it was for an American purchaser. It was resold at the Hartmann sale in 1880 for 133,000 francs. By the beginning of the sixties, however, Millet's reputation was no longer in question. At the

Paris Exposition of 1867 he was represented by nine pictures and received the grand medal. In the Salon of 1869 he was on the hanging committee! But he still continued what has been happily called his "life of sublime monotony"; his sojourn in Barbizon being interrupted only during the war of 1871, when he retired to Cherbourg, painting there some fine pictures of the sea. He died in 1875, at the age of sixty, and was buried in the little churchyard of Chailly, overlooking the forest. A rock in the latter bears a bronze tablet on which a sculptor has represented side by side the bust-
 portraits of Rousseau, the father of modern French landscape, and Millet, the artist of the people who work in the fields.

In his own words, Millet tried to depict "the fundamental side of men and things." His subject was the peasant life: not the representation of it such as one sees in opera, nor the pretty, sentimental aspect of it; but the actual drama of labor continuously proceeding through the four seasons—the "cry of the soil," echoing in the hearts of the patient, plodding, God-fearing toilers. Everything was typical. We have spoken of his "Sower." Of another picture the critic Castagnary wrote: "Do you remember his 'Reaper'? He might have reaped the whole earth!"

Everything that Millet did was full of a deep seriousness and sincerity. He never was an "easy" painter, so that his greatness as an artist is perhaps more clear in the black-and-white than in the colored subjects. Certainly in his crayon drawings, lithographs, and etchings he proved himself to be one of that limited number of artists who may be reckoned master-draftsmen. Moreover, the character that he expresses is of that grand and elemental quality which sometimes reminds us of Michelangelo.

Millet's influence produced a host of painters of the peasant, among whom the strongest are the Frenchman L'Hermitte, and Israëls the Dutchman. These, like him, have represented their subject with sympathy and with understanding also. Breton, however, has not.



BY THE SEA IN AUGUST WEATHER.

BY MARGARET HAMILTON.



BOARING waves and slippery sand—
 Dear me! I prefer the land!"
 That 's what Dora says, for she
 Thinks it 's dull beside the sea;
 But auntie, Dot, and you and I—
 We are n't lonesome, are we, Guy?

How can days be dull for her
 Here, where everything 's astir?
 Fish-hawks flap and dance and dive,
 And the marsh is all alive
 With the fluttering, rosy mallows,
 And the wee fins stir the shallows;
 Lantern-headed dragon-flies,
 Gleaming like the blue-green eyes
 In a peacock's gorgeous tail,
 Through the meadow sail and sail;
 Snipe above the breakers flit,
 With their tiny twit-twit-twit,
 Or perhaps go running past
 On their magic stilts, too fast

For the white-maned wave to reach
 As it races up the beach;
 Gray song-sparrows teeter-teeter,
 Swinging, singing, sweeter, sweeter,
 On the long, light-green sea-grasses,
 Swaying as the sea-breeze passes.
 When the wind blows from the west,
 Every wave will wear a crest,
 If it 's blue and sunny weather,—
 One fine rainbow like a feather!
 Sometimes, too, the billow brings
 Scores of fishes, helpless things!
 And along the sands they shine
 In a leaping silver line,
 Showing just the last wave's track;
 And I try to put them back.

Then the sunny afternoons
 All along the shining dunes!
 And the bathing! when you sway
 Up and down in foam and spray
 Till the breakers' plunging roar
 Sweeps you shouting back to shore!

Where could any mortal be
 Happier than beside the sea!



"THEN THE SUNNY AFTERNOONS
ALL ALONG THE SHINING DUNES!"

THE IMPUDENT GUINEA-PIG.

BY CHARLES F. LUMMIS.

No other creature is so absolutely graceful as a rattlesnake, and none more gentle in intention. It is only against imposition that he protests. Our forefathers had learned a not unworthy lesson from their contact with nature in the New World when they put upon the first flag of the colonies a rattlesnake with the Latin legend, *Nemo me impune lacessit*—"No one wounds me with impunity." The flag of independence, however, only half told the real meaning of its emblem—the warning, and not the self-restraint. There is a device, to my notion, much more expressive: a rattlesnake rampant, with the Spanish motto, *Ni huves ni persigues*—"Thou needst not flee, but thou must not pursue." Or, in other words, "I impose upon no one; no one must impose upon me." That is the real meaning of the rattlesnake, as any one can testify who knows him well.

I chanced one day to enter the market in Los Angeles, and was surprised to find in one of the stalls a large collection of rattlesnakes, mostly brought in from the Mojave desert. It was the first time I had ever seen the crotalus sold in the stalls of a city market; and as they went at the very reasonable figure of fifty cents apiece, I promptly purchased a pair. The dealer, with a noose of cord, lassoed the two I indicated, and after some manœuvring got them stowed in two large cigar-boxes which he tied up tightly. Reaching home safely with my new pets, I made them a roomy cage with wire-screen front and a sliding door on top, and transferred them to it without much difficulty. One was a strong, handsome fellow five feet long and with fifteen rattles; the other was about three feet in length and had an ordinary "string."

The dealer told me they had eaten nothing in six months; and fancying it must be about lunch-time with them, I went down-town, as soon as they were comfortably settled in the

new quarters, to get them food. A rattler, you know, will touch no dead meat, so I had to seek some living bait. After ransacking the markets I found at last one young *cuye*—the funny little South American, generally mis-called among us the "guinea-pig." It was about half-grown—a very proper-sized morsel for the larger snake.

My friends rattled a little as I opened the slide on the top of their cage, promptly closing it as I dropped the *cuye* in. But, to my surprise, they paid no further attention to the newcomer, except to appear very much bored by him; and, stranger yet, the guinea-pig showed no sign whatever of fear. I have so often watched birds, rabbits, dogs, horses, cattle, and other animals—up to the strongest and boldest—in presence of the rattlesnake, and have always noted in them such unmistakable tokens of terror, that it astonished me to find this pretty little white-and-tan creature so utterly unconcerned. In dropping from the door he alighted squarely upon the backs of the snakes, whereupon they drew away uneasily; and he proceeded to look and sniff about, very much as you may have seen a rabbit do. I stood by the cage a long time, expecting the snakes to lose patience at last and enact a tragedy; but nothing happened. The *cuye* scurried freely about the cage, generally treading upon the irregular loops which covered most of the floor; and the snakes neither rattled nor raised their heads at him.

For fully a week the three lodged together harmoniously. Sometimes, on entering the room, I found the guinea-pig quietly reposing inside the careless coil of one of his strange bedfellows. Several times he was squatting upon them, and more than once sitting squarely upon the head of one! I began to wonder if there were anything constitutionally wrong with the snakes. Whether they deemed him too big or too foolish to be eaten, I have never

known, but, whatever the reason, they made no motion toward eating him. Unfortunately, he did not know how to return a favor.

One afternoon I was writing at my desk, when a tremendous rattling behind me caused me to jump up and go to the cage. The smaller snake was up in arms, skirring his rattle violently, while the larger one was twisting uneasily about, but not showing fight. And what do you imagine ailed him? Why, that miserable cuve was perched upon him, coolly nibbling that beautiful rattle, of which only three or four beads were left! In my righteous indignation I tore open the slide and "snaked out" the vandal as quickly as possible. Afterward it occurred to me to wonder that I had not been struck; for nothing so alarms and angers a crotalus as a swift motion like that with which I had removed the cuve. The rattles never grew again, and my best snake was spoiled. Why the cuve should have cared to eat that mysterious husk which is so absolutely dry and flavorless, I can explain only by adding that rats and mice have the same perverted taste, and that it seems fairly a passion with them. I have had many skins and rattles eaten up by them.

Shortly after this episode one of our helpers in the office found a nest of mice, and, mindful of my hungry snakes, I contrived to catch

one mouse alive. When the rattlers saw him through their screen, they manifested such a lively interest as nothing had aroused in them before. I cautiously opened the slide in the top of the cage, held the mouse up by the tail, and let him drop.

There was a fair illustration of the matchless agility of the crotalus when he *cares* to be quick. The cage was just twelve inches high in the clear; but before the falling mouse was half-way to the bottom, there was an indescribable gray blur, and I knew that the larger snake had hit him. I have improved numerous chances to study the stroke of the rattlesnake, which is the swiftest motion made by any living creature; but that particular case, better than any other, gave me a conception of its actual rapidity. From years of experience with the pneumatic shutter in photographing objects in rapid motion, I should say the snake's head traversed that twelve or fifteen inches in something like the three-hundredth part of a second.

The mouse fell upon the floor of the cage, and it never moved again. The snake knew perfectly that it had done its work, for in place of "recovering" for another stroke, as they invariably do after a failure, he swallowed the mouse in the usual slow and painful fashion, with as much apparent effort as a morsel four times as large should have given him.

A MESSENGER.

By L. S.

LITTLE Jack by the seaside stands,
Watching the setting sun.
He runs to the beach at eventide,
For his day of play is done.

His father has gone to the China seas,
For a cruise of a year and more;
And little Jack is left behind,
On the edge of Long Island shore.

He kisses his hand as the sun sinks down,
And murmurs a message low:
"When you shine on father to-morrow morn,
Just tell him Jack says 'Hello!'"

"Supper is ready," the black nurse calls.
Jack answers, "I can't come, Dinah;
The sun has a message to give to dad—
I'll wait till he gets to China."

Nonsense Rhyme.

from the Negro quarters



JAY-BIRD a-sittin' on a Hickory limb.
He winked at me, I winked at him.
'Taint gwine to rain no mo'.



HAWK and BUZZARD went to law;
Hawk fell down and broke his jaw.
'Taint gwine to rain no mo'.



Oh, de Wren an de Thrush go clackety-clack,
Dey bofe talk at once an dey bofe talk back,
Dey say: "Jim Crow, my but you is black!"

'Taint gwine to rain no mo'.



THE OLD WIDOW AND HER CAT.

BY H. MARIA GEORGE.



IN Bruges, a city of the Netherlands, lived, a long time ago, a widow whose name was Mechie—the only name by which she was known. The country was called Flanders then, and was ruled over by a very powerful prince called an earl. There was

war in the land, for the Earl and his subjects did not live very pleasantly together, and many men had been killed, and, among others, Mechie's husband, whose name was Dolph. He had been but a simple diker; but if he had been a knight, Mechie could not have missed him more. Dolph had always been industrious and had received good wages for his labor, and Mechie had never known what want was while he lived; but now that her husband was dead, she was very poor; and often she could find no work, and so her provisions would run very low.

She lived in a small hovel in one of the dark, narrow lanes of the city. There was only one room on the ground floor, which was of earth covered with straw. A square window, with latticed bars across it in checkers, let in all the light there was. In the small fireplace hung the crane, and on it was the dinner-pot, which was often empty. Two or three wooden benches, a rough table, and a bed were the only furniture. On the table were some pewter and wooden dishes, and above it on the wall was a small brass lamp.

In one corner of the room stood a short ladder that led to the loft above, where the

children slept. The children and a large black cat were all Mechie had—she had no other friends in the world to whom she could apply for help or advice.

The cat had belonged to the oldest son, Max, who was gone to the wars to fight for his sovereign, Earl Louis. The cat's name was Nebuchadnezzar. Max had raised him from a kitten, and given him his name—a very large name, it seemed at that time, for so small a cat. He was now large, and proved to be a voracious eater; but, though she found it difficult to procure enough for all to eat, the widow kept him because he had belonged to her good, brave Max.

Two years before, Max, who was a sturdy lad, had helped his father, as a mason's apprentice, in the work upon the dike; but he had been absent more than a year now, and during the time Mechie had heard nothing from him. She began to fear that he was dead. There had been a number of battles, and in the last one the Earl had been defeated by his enemies.

Bruges itself was in a state of siege by the rebel men of Ghent, led by the brave and energetic Philip of Artevelde, a young man of great promise and ability.

Affairs grew worse daily for the poor widow. Food was scarce in the city and brought high prices, and Mechie could find no lace to weave, as she had formerly done. Tirelessly she walked up and down the now nearly deserted streets, and tried in all the shops to get work to do. The children could be spared but a pittance, and the widow herself often went supperless to bed.

Nebuchadnezzar was so lazy and exerted himself so little that he did not grow gaunt. Every day he sat on the window ledge, purring in the sun, as happy and contented a grimalkin as ever lived. Work he would not, and if he got a piece of barley bread or a black crust

from his mistress's scanty store, he troubled himself for nothing more save his long nap on the window ledge.

But things grew so bad at last that the widow began to fear that she could not get even a barley crust for her children, much less supply Nebuchadnezzar with a meal. Absolute hunger stared her in the face. There was not a crumb in the house to eat, and she was without money to buy anything.

Mechie was truly disconsolate. Her children were indeed quiet now; but on the morrow she knew there would be wailing for food, and where could she get any? There was no alternative but that they must starve.

At that moment her eyes chanced to rest on Nebuchadnezzar, who sat purring, with his eyes open, upon his usual throne. A thought as if born of inspiration rushed into her mind. In more prosperous days Berthold the Burgomaster had offered Max a gold piece for his cat, and Max had refused it. Would the rich burgomaster buy him now? If so, why not sacrifice him and save her children? They would grieve for the loss of their pet; but, at any rate, it was better than starvation. She wondered that she had not thought of it before.

The widow rose from her chair and approached the table. She looked at the boiling pot, and thought of the savory dishes that one gold piece would purchase.

Suddenly she paused. She thought of Max. What would he say if he should come back and find Nebuchadnezzar gone? The cat had been her boy's chief pet, and it was all she had now to remember him by. Even the cradle in which she had rocked him and the other children had been sold to buy food for her little ones.

The cat still blinked and purred on the window ledge, the very place where Max had taught him to lie. Mechie could almost see Max himself, just as he had stood there a thousand times in the old days. Tears sprang to her eyes as she thought of her dear boy.

Just then one of the children in the loft above awoke from her sleep and cried for something to eat. The cry went to the mother's heart. Max could not want them all to starve, and the price that Nebuchadnezzar would bring would prolong their lives for a few days at least. She crept softly up to the window ledge.

But Nebuchadnezzar seemed all at once to arouse from his usual idleness. Something in the widow's manner, the gleam of her eye, awakened his feline suspicions. With a yowl of mingled surprise and affright, he got up, looked hastily about him, and then sprang through the latticed window and dashed away.

Mechie sat down in her chair and cried. She was half glad that Nebuchadnezzar had escaped; but the thought of her starving children pierced her heart.

"Perhaps Nebuchadnezzar will come back in the morning, and there will yet be time." This was the thought in her mind as she went to sleep.

But when the morning came it did not bring Nebuchadnezzar. The house was lonesome without him. She kept the door open all day, but the cat did not return. When it was dark she closed the door and lit her lamp.

It was a still summer night, and for a long while Mechie heard nothing save the cry of a sentinel from time to time on the wall. This was a common greeting, and the widow kept on with her work,—the darning of a little ragged frock,—undisturbed by any thought of danger. She finished her task at last, and was about putting out her light when loud, fierce shouts startled her.

"Our enemies are in the city," she said to herself; and though she hated the men who had slain her husband, she was almost glad for her children's sakes, for she thought that now she could get something for them to eat.

She waited a long time, but the tumult seemed to increase rather than to diminish. Amid the shouting and the noise of tramping soldiery, Mechie heard a low, faint mew at the door.

"It is our Nebuchadnezzar," she thought; and she went to the door and opened it.

Sure enough, it was Nebuchadnezzar, who



rushed in with a glad cry, but behind him Mechie saw the tall figure of a man.

"I am Earl Louis, thy sovereign," said the stranger, hoarsely, and panting for breath; "and evil men seek my life. Give me shelter and refuge, and Heaven will reward you."



"SHE TRIED IN ALL THE SIGNS TO GET WORK TO DO."

"I am only a poor widow, but such as I have I give you," answered Mechie. "My lord, enter."

Never before had the powerful Earl of Flanders entered so humble an abode; but he was glad even for this refuge, for his strait was desperate. The widow conducted him to the loft and showed him six children asleep on a bed of straw.

"Conceal thyself quickly, for I hear thy pursuers already at the door," she said, pointing to the straw.

The great man hastily crept over the slumbering children, and, finding some loose straw, crept far under the eaves and heaped the straw over and beside him till he was completely hidden.

Meanwhile, a loud pounding had summoned the widow to the door again.

"Where is the man who has just entered thy hut?" demanded a savage man of Ghent,

"I am a widow and live here alone with my children," she answered, trembling with fear.

"Nay, but we saw the light upon the way, as it glared forth from the open door."

"My cat came in from the street. If there be a man within, search and find him."

The man cast a quick glance within. He saw the ladder leading to the loft, and, taking the light from the widow's hands, he hurriedly ascended. A row of children huddled together and a loose mass of straw was all that he saw, and he descended muttering.

"The hag is right," he grumbled. "There is only a nest of children sleeping together, and there is n't room enough for an ant to hide, much less the Earl of Flanders."

Uttering cries of balked vengeance, the throng of Ghent men pushed on, and patrolled the streets until morning, stopping every person who, as they thought, might in any way be connected with the Earl of Flanders, or endeavoring to be in communication with him.

In the meantime the Earl, with a thankful heart for his wonderful preservation, went to sleep in the company of the young children who shared his humble couch of straw. Sorely wearied by fatigue, he slept as soundly in the mud hovel of the poor widow as though he had lain on a down bed in one of his own palace chambers.

The next morning was the Sabbath, and the great Earl was awakened by the wondering cries of the children.

"How funny! Brother Max has come to bed with his clothes on," cried one little boy.

"Hush, Minna!" cried Hans; "it is not Max, and he may be angry with you for mistaking his name."

"Nay, I am a friend to you all," said Earl Louis. "From this hour forward count the Earl of Flanders your protector."

The children were awed to silence at the mention of that great name, and the Earl presently descended to the lower room, in which he found the devout widow singing her Sunday-morning hymn. When Mechie saw him she gave a great cry.

"Where is my son? Oh, tell me, where is Max, my boy? 'Thou hast on his clothes!'"

The Earl looked first at the widow and then at his clothes, and then he noticed a great black cat purring about his feet, for Nebuchadnezzar had jumped from his perch and

"The hand of God is in it!" cried the Earl solemnly. "Much do I owe thee and thine. It was thy son who risked his own life by making this generous exchange. And if it had not been for this black beast here, I never should have found thy cot," and he stooped and stroked the soft hide of Nebuchadnezzar.

"I was wandering, lost and exhausted," continued the Earl, "when this cat rushed out from a dark corner, appearing as if pleased to see me. Following him, I came to your door. A moment before I had given up all hope of life, for my enemies were coming up from every side, let in by that traitor, De Mareschant."

"And the night before I was going to sell the faithful fellow," said the widow; "for we were starving; and now my sovereign owes him his life."

"Thou shalt know want no longer, nor shall thy family," he said, plac-

ing in her hands a purse of gold crowns. "Let thy children now go and buy bread."

"I will take only enough to buy us some food," interrupted Mechie. "The rest thou needest more than we, for thou art not yet out of danger, and it has cost us nothing to shelter thee. It is almost like seeing Max to see thee here."

"When I have my rights again the widow of Dolph the diker shall not regret that she entertained her sovereign," replied the Earl; and he did not forget his promise.

He stopped all that day with the widow, keeping a better Sabbath than he had for a long time before; and the following night succeeded in making his escape out of the city, still disguised in the humble dress that had



"IT WAS NEBUCHADNEZZAR, AND BEHIND HIM MECHIE SAW THE TALL FIGURE OF A MAN."

approached him as though he were an old friend.

"The clothes are not my own, surely; but whose they are I cannot say. I took them in exchange from a friendly stranger, who wore away my own princely suit."

"It must have been my son Max, for the clothes are those of my own making," asserted Mechie. "He wore them away from here a year ago, when he went to fight under your banner against the men of Ghent."

"If indeed 't was he, he has won his golden spurs," said Louis. "But who art thou to whom the Earl of Flanders owes his life?"

"I am the widow of Dolph the diker, whom the men of Ghent slew when he was at work for his sovereign, and Max is my oldest son."

been worn by Max. In the meantime Max was having exciting adventures. On one occasion he was set upon by a burly man of Ghent who, seeing on Max the remnant of the Earl's fine clothes, believed him to be one of that noble's courtiers. He was obliged to defend himself with his sword. Although his antagonist was much larger than he, his youth and agility served him, and he managed to disable his opponent sufficiently to permit of his own escape. He finally succeeded in re-joining the forces of the Earl, who had reached Lisle, one of his loyal towns, in safety; and an army soon gathered



"ON ONE OCCASION MAX WAS SET UPON BY A BURLY MAN OF GHEENT."

was slain. Ghent and Bruges were delivered up to him, and Flanders once more passed under the sway of its rightful lord.

Max was found with the Earl's velvet mantle and plumed cap upon his person, and Louis himself went with him to his mother's. There was rejoicing that night in the widow's cottage. The children each had a present, and even Nebuchadnezzar was not forgotten.

But there was a statelier ceremony the next day at the Earl's castle, when Max had the honor of knighthood bestowed upon him, and was given jewels and a velvet mantle of his own.

Meehie and her children all became the protégés of the Earl, who gave them a fine large house and gold enough to enable the widow to pass her last days in comfort.

As for Nebuchadnezzar, he grew lazier and fatter still, and loved the sunlight more and more. But he did not now sit on a hard wooden window-seat as formerly. He had a cushion made of velvet and edged with gold lace, and wore a

collar all of gold; for Max said that if it had not been for the faithful cat, they would none of them have found their good fortune.



"THEY PATROLLED THE STREETS, STOPPING EVERY ONE WHO, AS THEY THOUGHT, MIGHT IN ANY WAY BE CONNECTED WITH THE EARL OF FLANDERS."

around him quite large enough to enable him to take the field against his rebellious subjects.

In a great battle he completely defeated the

WARBLER WAYS.

With photographs by Herman T. Bohlman.

BY WILLIAM LOVELL FINLEY.

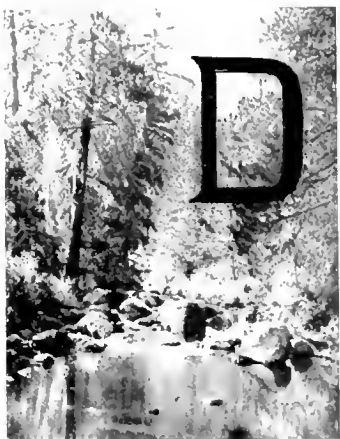

DURING the warm days of June, when the mystery of life seems suddenly unveiled in a miraculous manner, I often frequent a woody retreat above the old mill-dam on Fulton Creek. The water gurgles among the gray rocks and glides past a clump of firs and maples. Star-flowers gleam from the darker places of shade, white anemones are scattered in the green of the grass-blades and ferns, and Linnean bells overhang the moss-covered logs.

As one sits here in the midst of the woods the chords of every sense are stretched. His eye catches the cautious movements of furry and feathered creatures. His heart vibrates with the rhythmic throbbing of the forest pulse.

One day, as I lay idling in this favorite haunt, a shadow caught in the net of sunbeams spread under the maple. A black-throated gray warbler fidgeted on the limb above with a straw in her bill. This was pleasing. I had searched the locality for years, trying to find the home of this shy bird, and here was a conclusive piece of evidence thrust squarely in my face.

The site of the nest was twelve feet from the ground, in the top of a sapling. A week and a half later, I parted the branches and found a cup of grasses, feather-lined, nestled in the fork of the fir. There lay four eggs of a pinkish tinge, touched with dots of brown.

The chief source of satisfaction in a camera study of bird life comes not in the odd-time chances of observation, but in a continued

period of leisure, when one may spend his entire time about bird homes just as he takes a week's vacation at the sea-shore. To be a successful amateur bird-photographer one has fairly to make a business of lying in wait for his subjects hour after hour, day by day, and maybe week after week.

The real value of photography is that it records the truth. The person who photographs birds successfully has to study his subjects long and carefully. He is not likely, therefore, to get only a scanty set of notes and be compelled to complete his observations when he is seated in the comfortable chair of his study. For this reason, a camera in the hands of some of the recent nature-writers would be of great value to science, if they could picture some of the humanized habits of creatures they have described with the pen. Of course, in the study of art, we may try to improve on nature, but in nature-study truth is the important element. We might as well understand that a beast or bird is interesting because of its own wild individuality, not because it is a man dressed in fur or feathers.

Of course it showed a pure lack of discretion to try to picture the home of such a shy warbler during the days of incubation, but I half believe the feathered owners would have overlooked this, had it not been for the pair of blue jays that bucanereed that patch of fir. While we were getting a picture I saw them eying us curiously; but they slunk away among the dark firs, squawking jay-talk about something I did n't understand. Two days later we skirted the clump to see if the sense of warbler propriety had been too severely shocked by the camera. In an instant I translated every syllable of what that pair of blue pirates had squawked. The scattered remnants of the nest and the broken bits of shell told all.

These gray warblers, however much they were upset by the camera-fiend and blue-jay

depredations, were not to be thwarted. They actually went to housekeeping again within forty yards of the old home site. The new nest was placed in a fir sapling very like the first, but better hidden from marauding blue-jays. It was supremely better located from the photographer's point of view. Just at the side of the



"A CUP OF GRASSES, FEATHER-LINED, NESTLED IN THE FORK OF THE FIR."

new site was the sawed-off stump of an old fir, upon which we climbed and aimed the camera straight into the nest. There, instead of four, were only two small nestlings. They stretched their skinny necks and opened wide their yellow-lined mouths in an attitude of unmistakable hunger.

The moment the mother returned and found us so dangerously near her brood, she was scared almost out of her senses. She fell from the top of the tree in a fluttering fit. She caught, quivering, on the limb a foot from my hand. Involuntarily, I reached to help her. Poor thing! She could n't hold on, but slipped through the branches and clutched my shoe. I never saw such an exaggerated case of the chills, or heard such a pitiful, high-pitched note of pain. I stooped to see what ailed her. What! both wings broken and unable to hold with her claws! She fell like an autumn leaf to the ground. I leaped down, but she had limped under a bush and suddenly got well. Of course I knew she was tricking me.

The next day my heart was hardened against all her alluring wiles and "crocodile" tears.

She played her best, but the minute she failed to win I got a furious berating. It was no begging-note now. She perched over my head and called me every name in the warbler vocabulary. Then she saw we were actually showing that cyclopean monster right at her children. "Fly! fly for your lives!" she screamed in desperation. Both the scanty-feathered, bobtailed youngsters jumped blindly out of the nest into the bushes below. The mother outdid all previous performances. She simply doubled and twisted in agonized death-spasms. But, not to be fooled, I kept an eye on one nestling and soon replaced him in the nest where he belonged. Nature always hides such creatures from me by the simple wave of her wand. I've seen a flock of half a dozen grouse flutter up into a fir and disappear, to my eyes, as mysteriously as fog in the sunshine.

This fidgety bit of featherhood is called the "black-throated gray warbler," but it is only the male that has a black throat. He is not the whole species. His wife wears a white cravat, and she, to my thinking, is a deal more important in warbler affairs. Mr. Warbler seemed unavoidably detained away from home on matters of business or social importance the greater part of the day, when the children were crying for food.

The first day we really met the gentleman face to face we were trying to get a photograph



"THERE, INSTEAD OF FOUR, WERE ONLY TWO SMALL NESTLINGS."

of the mother as she came home to feed. She had gotten quite used to the camera. We had it leveled point-blank at the nest, only a yard distant. A gray figure came flitting over the

tree-top and planted himself on the limb right beside his home. He carried a green cut-



"I'VE OFTEN SEEN DISPUTES ARISE WHILE THE MOTHER WAS AWAY."

worm in his mouth. No sooner had he squatted on his accustomed perch than he caught sight of the cyclops camera. With an aston-

I could not tell one nestling from the other. As I sat watching the mother the questions often arose in my mind: Does she recognize one child from the other? Does she feed them in turn, or does she poke the food down the first open mouth she sees? Here is a good chance to experiment, I thought. So with a good supply of 5 by 7 plates we watched and photographed from early in the morning till late in the afternoon for three days. At the end of that time we had eight pictures, or rather four pairs, each of which was taken in the same order as the mother fed her young.

The warblers foraged the firs for insects of all sizes and colors. The digestive organs



"THE MOTHER FED THE NEAREST NESTLING."



"FOR ALL HIS BEGGING THE NEAREST GOT A KNOCK."

ished chirp he dropped his worm, turned a back somersault, and all I saw was a meteor streak of gray curving up over the pointed firs. I doubt if he lit or felt any degree of safety till he reached the opposite bank of the river.

We met his lordship again the following day. The mother was doing her best to lure us from the nest by her deceiving antics. Every visit we had made she kept practising the same old trick. Just as she was putting on a few extra

of those bobtailed bantlings seemed equal to almost any insect I had ever seen.

In the days we spent about the nest I never saw the time when both the bairns were not in a starving mood, regardless of the amount of dinner they had just swallowed. The flutter of wings touched the button that seemed automatically to open their mouths. At the slightest sound I've often seen disputes arise while the mother was away. "I'll take the next!"



"THE GRAY MOTHER REWARDED HIM WITH A MOUTHFUL THAT FAIRLY MADE HIS EYES BULGE."



"ON HER RETURN, SHE DID NOT FORGET THE HUNGRY FLEDGLING STILL IN THE NEST."

agonizing touches, I suddenly saw a glint of gray shoot through the air. The father pounced down and drew the feigning mother away.

said one. "I guess you'll not!" screamed the other. The mother paid no more attention to their quarrels and entreaties than to the cease-

less gurgle of the water. How could she? I don't believe she ever caught sight of her children when their mouths were not open. The fact that the mother fed them impartially appealed in no way to their sense of justice. The one that got the meal quivered his wings in ecstasy, while the other always protested at the top of his voice.

The first pair of pictures in the series was taken while the young were still in the nest.



"FIRST THE RIGHT RECEIVED A TOOTH-SOME MORSEL."



"SOON AFTER THE HUNGRY BIRD ON THE LEFT GOT A JUICY BITE."

The mother fed the nearest nestling. Changing the plate and adjusting the camera again, we had to wait only three minutes. The bairn at the edge of the nest surely had the advantage of position. But what was position? For all his begging the nearest got a knock on the ear that sent him bawling, while his brother gulped down a fat spider.

Soon after one of the bantlings hopped out on the limb, and the gray mother rewarded

fed only from the right. This looked good to the first little chick, for he seemed to reason that when he opened his mouth wide his mother could not resist his pleadings. He reasoned rightly the first time. On the second appearance of his mother, position did not count for much: it was his brother's turn.

Later in the day I watched the gray warbler coax her two children from the high branches of the fir into the thick, protecting

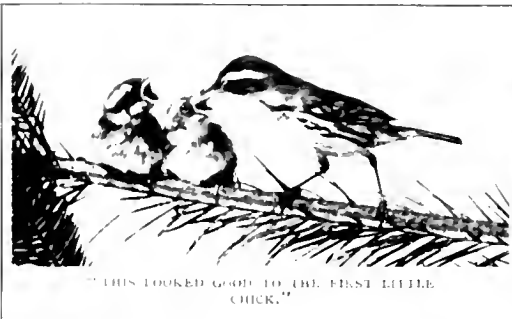

"THIS LOOKED GOOD TO THE FIRST LITTLE CHICK."



"ON THE SECOND APPEARANCE POSITION DID NOT COUNT FOR MUCH: IT WAS HIS BROTHER'S TURN."

him with a mouthful that fairly made his eyes bulge. On her return, she did not forget the hungry, more timid fledgling still in the nest.

bushes below. With the keen sense of bird motherhood she led them on, and they followed out into the broad, wide world of bird experience.

MARY AND HER GARDEN.

DRAWN BY KATHARINE GASSAWAY.



MARY, MARY, QUITE CONTRARY, HOW DOES YOUR GARDEN GROW
WITH LARKSPUR AND PHLOX,
AND LAISIES WITH STOCKS,
STIFF AND FRIM, BY THE WALL, IN A ROW.

THE PRACTICAL BOY.

BY JOSEPH H. ADAMS.

TENTH PAPER.

BIRD-BOXES, RABBIT-HUTCHES, AND OTHER PET SHELTERS.

BIRD-BOXES.

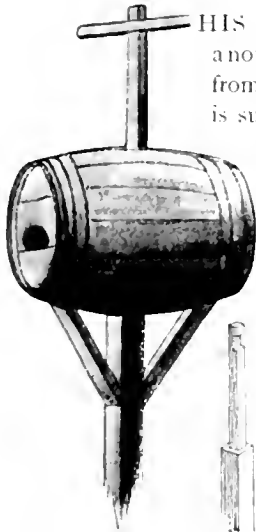

FIG. 1.
A NOVEL BIRD-BOX.

HIS initial illustration shows a novel kind of bird-box made from a small keg. The keg is supported at the top of a post and braced at the bottom with two bracket-pieces. A hole $2\frac{1}{2}$ inches in diameter is made at each end of the keg, through which the birds can enter; and the post to which the keg is fastened is cut away at the upper end, as shown in Fig. 2. In one side of the bilge of the keg a hole is cut as large as the post is square or round, and at the other side

a corresponding hole is cut the size of the upper part of the post. The keg is then dropped down over the post so that the shoulder, formed by cutting away the wood, will rest under the upper side of the keg, in which the smaller square hole has been cut.

Bird-houses of an infinite variety of styles can be made by any handy boy. The following directions for pigeon-cotes will serve for these, except that the bird-boxes will be smaller, and perches will be more appropriate than platforms for the birds to alight upon.

PIGEON-COTES.

FOR ordinary pigeons that fly about the house and barn open cotes will answer; but for valuable pigeons a large wire inclosure should be

made and the lodges placed within them—unless the birds are very tame and will not leave the premises.

Some small pigeon-cotes are pictured in this article. In Fig. 5 a cote with three holes is shown that is easily made from thin boards.

It may measure 30 inches long, 9 inches wide, and 12 inches high at the back, while at the front the board with the holes cut in it may be 9 inches wide, with the holes 5 inches high and 4 inches wide. The wood is put together as

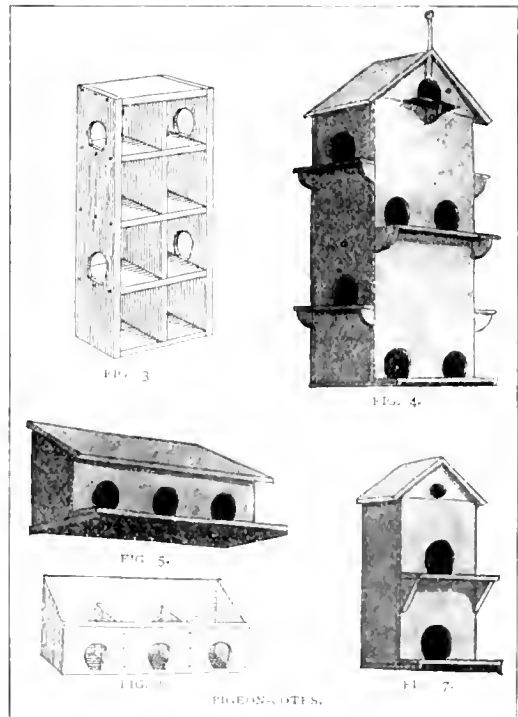

shown in Fig. 6, and the roof boards overhang the ends and front for an inch or two. The upper ends of the two divisions need not extend beyond the height of the front board,

for when the birds are in, this space will give good ventilation. Provide a ledge 3 inches wide, as shown in the cut.

The entrances to the cotes shown in Figs. 3 and 4 are alternated from front to sides. Outside each entrance a ledge 3 inches wide is supported on brackets, and under the pitched roof the ninth compartment is arranged.

A two-compartment cote is shown in Fig. 7, and under the peaked roof a bird-house is made, to which access can be had through a two-inch hole in the peak.

CHICKEN-COOPS.

EVERY boy is familiar with the ordinary barnyard chicken-coop, but we give here a novel kind that will be found thoroughly practical. In this a canopy fly of muslin or a piece of stout dress goods is arranged at the front to keep off rain and to give shade. This coop is 3 feet long, 2 feet wide, and 30 inches high at the front, but at the back it need not be more than 24 inches high.

It may be constructed from boards with matched edges, or perhaps from a dry-goods case; and if it is raised from the ground an inch or two, and a few holes bored in the bottom, you will be sure of a dry floor. The cross-rail at the bottom, to which the upright slats are nailed, is 3 inches above the floor.

Outriggers can be nailed at each end so that

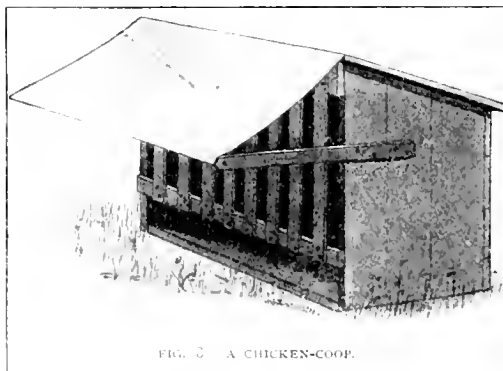

about 15 inches of the wood shall project beyond the sides, where a strip may be fastened between the ends. Light canvas or muslin is then tacked to the roof and strips; and with a coat of paint the coop will appear as in the illustration.

BIRD-SHELTERS.

BIRDS do not always seek the shelter of trees in a storm; they will hover about the house and barn, under the eaves and piazza-sheds, where they are protected from the rain and the drippings from wet leaves.

A good shelter is made from a flat barrel-hoop loosely covered with canvas or muslin tacked all around the edge. In the top of a post a wooden peg is driven, and over this the middle of the canvas disk is slipped, a hole having first been made (double-seamed) in the fabric through which the peg can pass. Four wires are to be

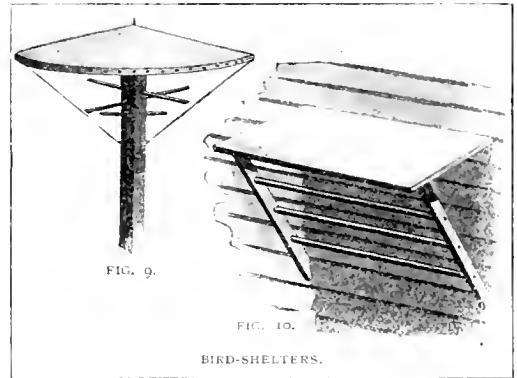

attached to the hoop at equal distances apart, and the lower ends are caught through screw-eyes driven in the post a foot or two from the top. Two or three holes can be made through the post, in which perches may be driven.

A shelter for the side of a house or barn can be made from a piece of thin board, two bracket-strips, and three long dowels or round sticks to act as perches, as shown in Fig. 10.

SQUIRREL-CAGES, ETC.

FOR squirrels, chipmunks, and white rats some very good cages can be made from wire cloth, tin boxes, and wood. A base-board is cut 28 inches long, 15 inches wide, and $1\frac{1}{4}$ inches thick (see Fig. 11). Ten inches from one end the edges of the board are tapered off so that the end will be 6 inches wide. Eleven inches from the small end a square piece of wood is mounted on the base-board to form the back to the compartment. This is covered with tin on

the inside, so that the rodents cannot gnaw the wood away at the edges or about the hole that leads into the cylinder. From thick wire a 3-sided frame is made and driven into holes at

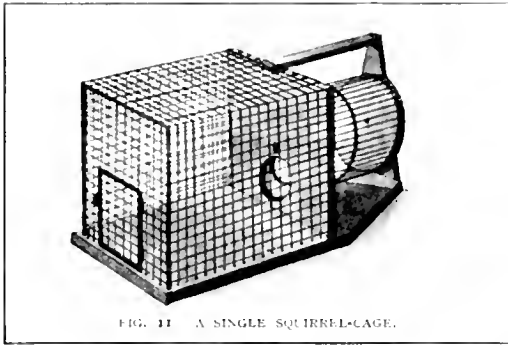

FIG. 11. A SINGLE SQUIRREL-CAGE.

the corners of the wide end of the board. It should be the same size as the back board, and is placed there to support the wire cloth of which the cage is made. Small holes are made in the base-board with an awl; the ends of the wire cloth are slipped into them and bent over. The edges of the cloth are tacked to the back board and wired to the 3-sided wire frame at the opposite end. A wire-screen door can be hung on hinges which may be soldered to the galvanized cloth; and with straight wires or wire cloth an exercising cylinder can be made with wooden or tin ends and supported between the back of the cage and the wedge-shaped upright.

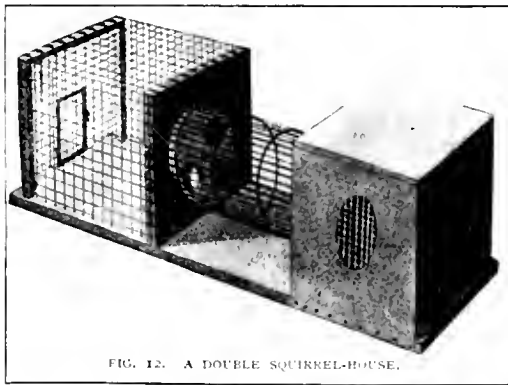

FIG. 12. A DOUBLE SQUIRREL-HOUSE.

The squirrel-house (Fig. 12) is constructed in the same manner as the cage, but it has the advantage of a covered shelter at one end of the base-board. This is made from a tin cracker-box with the lid removed and inverted so that

the bottom acts as the roof. In one side an oval opening is cut, and a wire screen is fastened to it at the inside.

The wire cylinder is 7 inches in diameter and 12 inches long—quite large enough for two squirrels to run a race in at the same time.

REPTILE-PENS.

THE lizard-run shown in Fig. 13 is made from a wooden shoe-case, open at the front, on top of which a smaller box is mounted and connected with the lower one by means

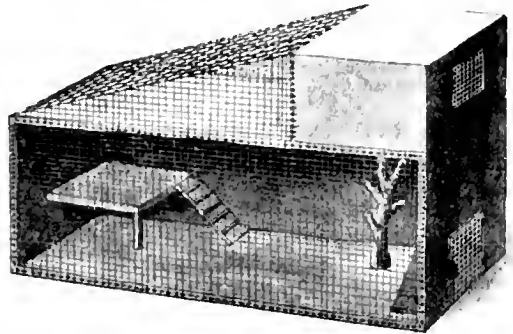

FIG. 13. A LIZARD-RUN OR REPTILE-HOUSE.

of an opening and an inclined board down which the lizards can crawl. A ventilator is cut in the upper box and covered with wire netting; and in the lower box, at one end, a doorway is made, 4 by 6 inches, and protected by a heavy wire-screen door on hinges. A raised platform, with a ladder, is made at one end of the large box and located in the open space; one or two tree branches can be made fast on which the lizards can climb.

RABBIT-HUTCHES.

IN Fig. 14 a simple double-floored rabbit-hutch is shown, and if it is made large enough quite a family of rabbits can live in it, the larger ones downstairs and the smaller ones upstairs, where an inclined plane will make it possible for the friends and relatives to visit one another from floor to floor.

This hutch may be from 4 to 5 feet long, 24 inches wide, and 24 inches high. The second floor is arranged so that it will be midway between the top and bottom, and at the rear an opening 5 inches wide and 10 inches long will re-

ceive an inclined board across which short sticks have been nailed to prevent the rabbits slipping. At one end a compartment is made 18 inches

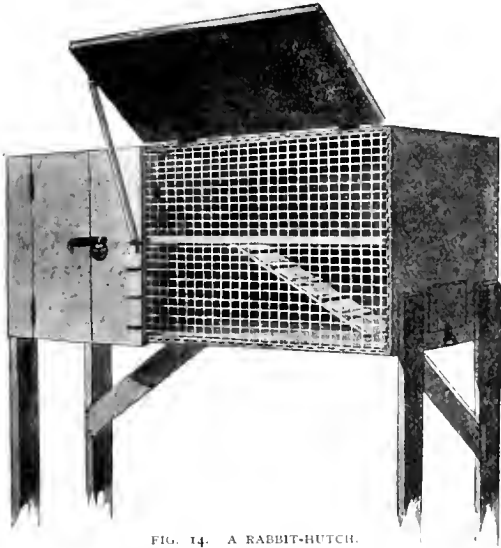

FIG. 14. A RABBIT-HUTCH.

wide, and provided with a door 6 inches wide, hung on hinges, and fastened with a hasp and lock. Openings 5 inches wide and 6 inches high are cut in the side of this compartment, so that the rabbits may enter it from either floor.

A drop front, on hinges, will permit the hutch to be partially closed in very severe weather; but when it is pleasant the front can be raised and propped up with a stick in the ends of which hooks are arranged that will fit into screw-eyes driven into the lid and along the side of the compartment, as shown in the illustration. In the end of the hutch, opposite the bottom of the stairway, a feeding door 6 inches square can be cut with a compass-saw.

This hutch should be supported on stout sticks or posts embedded in the ground for at least 2 feet, and it should be from 30 to 40 inches high. Across the open runs galvanized-wire cloth, with from $\frac{1}{2}$ to $\frac{3}{4}$ inch meshes, is to be nailed fast with staples.

DOG-KENNELS.

THE size of a kennel must be governed somewhat by the size of the dog; but for, say, a set-

ter or collie, a kennel similar to those shown in the illustrations may be from 3 to $3\frac{1}{2}$ feet long, 2 to $2\frac{1}{2}$ feet wide, 2 feet high at the sides, and 3 feet from the ground to the highest part.

A batten is nailed across the top of the front, sides, and back, to which the upper ends of the boards and the roofing boards are nailed; and at the top of one or both of the sides, or at the rear, a ventilator is cut with a bit and compass-saw. The kennel may stand alone out in the open, or may be built against the side of a house or barn. When built against a building a strip is fastened to the siding of the building, on which to nail the roof boards. In such a "lean-to," the wall of the building may be used as the fourth side of the kennel.

A swinging door is sometimes hung in the opening. This is a weather door, and is made an inch narrower on each side than the width of the doorway, and is hung on screw-eyes and staples so that it will act as a flap that can be pushed in or out by the dog when entering or leaving the hut. In the winter-time and when it is raining, this door will keep out snow and

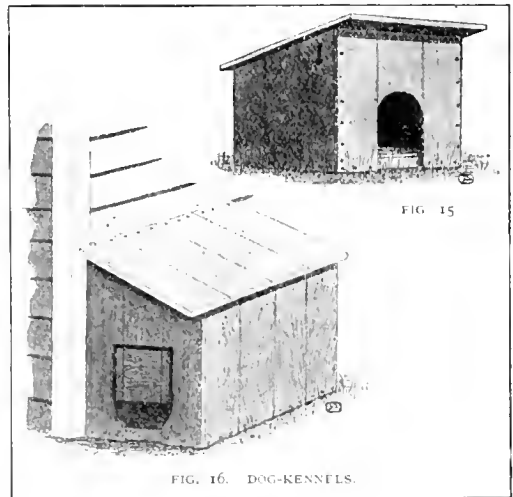

FIG. 16. DOG-KENNELS.

water and also protect a dog from strong winds. A little straw or matting or an old piece of carpet on the floor of the kennel will make it more comfortable for dogs, who will be very grateful for any kindness shown by their masters in providing for their comfort.

YE SOFT LITTLE MAID & YE HARD-SHELL CRABBE.

BY STEPHEN BEAUK.



“Oh, you funny old crab, why are you so
slow?
With so many legs you should faster go.”
But scarce had she spoken when, quick
as a flash,
Straight for the young lady the crab
made a dash.
And what happened next the picture
will show,
For off limped the wee maiden, a-crying,
“Oh! Oh!”



A SMALL MUSICIAN.

In the sunny South, at the river's mouth,
Sat a crab by the sounding sea,
And he played him a tune by the light of the moon,
For a fiddler-crab was he.

Norman W. Gray.

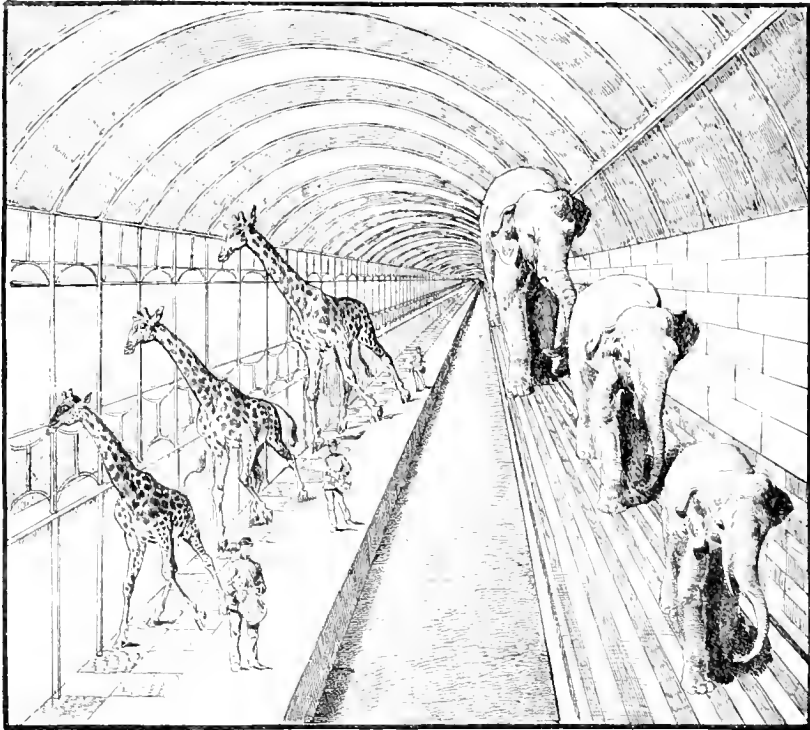

AN OPTICAL ILLUSION.

By B. C. J.

THERE is a remarkable picture painted by the celebrated English painter Hogarth. It is called "False Perspective." There are houses in the foreground, a stream in the middle distance, and a hill in the background. In a spirit of humor, Hogarth has filled the picture with impossibilities from the standpoint of perspective, and yet at the first glance a careless observer would detect nothing wrong in it.

Here is a somewhat similar picture that shows what a queer-looking jumble would result if the artist should neglect the rules of perspective in parts of his drawing and follow them in others.

If you were asked to point out which of the three elephants and which of the three giraffes traveling through the long, queer-looking corridor or bridge shown in the accompanying picture are the tallest, would you not at once place your finger upon the hindmost animals? The giraffe that brings up the rear seems to

overtop the other two, and the elephant in front appears but a dwarf compared with his big brother occupying the last place behind; and yet, surprising as it may seem, you will find, by carefully measuring the heights of the animals, that the nearest ones are really either taller than those that follow, or fully equal to them in size.

The reason that the latter look so much larger than they really are is because they do not grow smaller in the same proportion as do their surroundings, which are drawn according to the rules of perspective.

For you will notice that the lines of the roof, floor, and sides of the building grow closer together as they vanish in the distance. The illusion is further emphasized by the three men on the platform. These also are drawn in accordance with the laws of perspective—that is, they appear larger or smaller according to their distance from the eye of the observer.

FIRST AID TO THE INJURED.

BY DR. E. E. WALKER.

IV. SUNSTROKE.

"WHAT queer names the Indians used to have!" said John, as they were walking along the road one afternoon. "I have read about them at home; an Indian who lived in this valley was named Cornstalk because he was so strong and his people could lean and depend upon him. Another was called Big Foot. He was very large and very strong; in fact, a regular giant. He was, besides, a celebrated chief of the Wyandottes."

"You have a good memory, John," said Guardie.

Just here Sarah, Abe's sister, who with Abe had been invited over to the camp for the day, chimed in and said: "Mr. Wilson, father has told me that the Indians greased their bodies so that when they had a hand-to-hand fight they could slip out of the grasp of their enemy like a greased pig."

"Yes, that is true," said Mr. Wilson. "You saw, at the county fair last summer, the race after the greased pig, did n't you, boys? Well, just imagine how hard it would be, when you are wrestling in the 'gym,' if the body of the boy you are trying to throw were slippery with oil or grease, like those pigs."

"They could get plenty of oil in this part of the country in these days, could n't they, Guardie?" said Jerry.

For along from place to place in the Ohio Valley are the wonderful oil-fields with the derricks raising their tall heads here and there; and this is one of the most noted oil-regions in the world. These derricks had interested the boys very much, and they asked many questions about them. Mr. Wilson took them out one day and showed them a genuine oil-field, where the pumps were at work and the oil was flowing out. This afternoon he had planned a surprise for the boys in the way of a trip out into the country to an old farm-house on the main-

land, where they could be sure of a good supper. On the way they passed the oil-wells, noticed the many-colored effects of the oil which lay on the surface of the river, and saw the rows on rows of workmen's cottages down in the valleys. Finally, as they were passing a large farm made up of a long stretch of land with very few trees, Mr. Wilson saw something wrong among a group of men who quickly gathered about one of their number.

"Ah, boys," said he, "one of those men has a sunstroke."

Guardie stopped the horses, handed the reins to John, and, quickly jumping down, went up to the little group.

"What 's the matter, men?" he asked; "a sunstroke?"

They nodded their heads, and one of them said: "He has told me all day that his head hurt him and that he felt weak and dizzy. I tried to make him stop working, but he kept right on, and now I guess he 's done for."

Mr. Wilson looked at the man and told the others to carry him up under the shade of the one friendly tree that stood near. He then asked if they had any water. The men said that there was a well near by, and they went for a bucket of its cool water. Sarah had jumped down and was standing at Mr. Wilson's side, so that she might help if there was any chance. This soon came, for Mr. Wilson said, "Sarah, I wish you would run up to the farm-house and ask them to give you a towel and a pan of cracked ice." Sarah soon returned with the ice, which Mr. Wilson told her to wrap in the towel and lay on the man's head. He then thoroughly sponged the head and chest of the unconscious man with the cold water until he opened his eyes and began to breathe naturally. "That was not a very bad attack," said Mr. Wilson. He then told the men to carry the

sick man to the house and put him to bed in a large, airy room; for, as he told the boys, people who live or sleep in close, unventilated rooms, and those who use alcohol freely, are far more liable to attack by sunstroke than those who breathe pure, fresh air both by night and day and who let alcohol alone.

As they started on their way again, John said: "Guardie, how did you know that man had sunstroke? How does any one feel before he gets a sunstroke?"

"Well, John, in most cases there is pain in the head, which this man had; you often feel heavy at the pit of your stomach, and dizzy and faint, and begin to find that you can't breathe very well. Oftentimes, too, the mind is a little queer and your thoughts wander. Generally the skin is hard and dry. Sunstroke comes on in very hot weather, generally after it has lasted for quite a while. People who get sunstruck are often those who have worked very hard and have not drunk enough water; as I said before, people who drink alcohol and those who breathe impure air are far more apt to be overcome by the heat."

"What's the best thing to do for a person with the sunstroke?" John asked.

"First take him to a cool place. But, really, the best thing is to put him into a bath-tub which is filled with cool water. The whole body should be put in—except the head, of course. And then do as I did—put an ice-cap on the head."

"How long should a person be kept in the bath, Mr. Wilson?" asked Sarah, who had been very much interested in everything that had gone on.

"For about ten or fifteen minutes," said Mr. Wilson. "He should then be taken out and placed in bed, between blankets, without being dried. If the patient stops breathing, then begin artificial respiration, as I explained to you in our talk on drowning."

"Does the first bath always bring him round all right?" asked Jerry.

"No," said Mr. Wilson; "and then a second bath should be given—that is, if his body gets hot again and he becomes stupid. You don't need medicine at this time, unless, as sometimes happens, a stimulant is necessary, and one of the best is aromatic spirits of ammonia."

"Oh," said John, "mother always has that at home; and you would give fifteen or twenty drops in a tablespoon of water every few minutes, till three or four doses have been taken, would n't you, guardie?"

"Good, John!" said Mr. Wilson. "You have n't missed your calling, I see. Now, boys and Sarah, what would you do to keep off sunstroke?"

"Well, guardie," said John, "if I were a doctor and had to look out that my patient did n't get sunstruck, I'd tell him he could n't drink any beer, or wine, or anything like that."

"And I'd tell him that he must sleep a lot, and keep his windows wide open all the time," said Jerry.

"And I'd make him take a bath every night," said Sarah; "and I would n't let him eat a whole lot of pie and candy."

"Now, Abe, it's your turn," said Mr. Wilson.

"Well," he drawled, "I would n't let him drink ice-water, but I'd make him drink a lot of spring-water between meals."

"Well, children, you've told almost all of the things," said Mr. Wilson; "but you have n't said anything about your patient's clothes. You must make him wear light-colored things, and loose-fitting, as they do in all hot countries. But the hat's the most important part of all."

"Oh, yes," interrupted John; "it should be straw."

"Yes, and one that will let the air in," said Mr. Wilson. "And if you have to be out in the sun, it is a fine thing to put a wet handkerchief or some damp leaves on top of your head, under your hat. When I was a boy, we always put plantain leaves in our hats when we were out playing. But even if you've done all these things, and begin to feel queer out in the sun, what would you do?"

"I'd run for a cool, shady place, and rest, and drink some cold water," said Jerry.

"That is about the best thing you could do," said Mr. Wilson.

"Guardie, what would you do for sunburn?" said John.

"Apply the same treatment that you would for any burn," replied Mr. Wilson. "Put on plain baking-soda, or vaseline mixed with soda. This will take out the smart."

A DIFFICULT SUBJECT.

DRAWN BY E. WARDE BLAISDELL.



PHOTOG. APHER: "WELL, MADAM, IF YOU INSIST UPON A FULL-LENGTH PORTRAIT, I'LL HAVE TO TAKE YOU IN SECTIONS."

BEEES AS DESPATCH-BEARERS.

BY JAMES C. BEARD.

A VERY curious and interesting investigation has been going on for some time past among naturalists with regard to the senses of the lower animals. It has been found that in most cases these are very different from ours, and it cannot any longer be denied that instances occur in which special senses that are not possessed by human beings are developed in animals. One of these, called "the sense of direction," enables bees to return from long distances to their hives, unaided by any of the five different ways we have of recognizing our surroundings.

To test this matter thoroughly, the little honey-makers have been taken considerable dis-

tances from their hives, to localities which it was certain that they had never before visited; yet when set free they flew as unhesitatingly, as directly, and as unerringly home as from places perfectly known to them.

A few years ago it occurred to a well-known bee-keeper that this remarkable ability on the part of bees might be made useful. Convincing himself that he could rely upon their speedy return from anywhere within the range of three or four miles from their hives, whether they had ever been at the place from which they started homeward or not, he set to work to test their ability to carry messages as do homing pigeons. He accordingly procured a few bees

from a friend who lived on the further side of a barren, sandy tract of land which, offering no inducements in the way of possible food supplies, was never visited by the insects, and crossed over to his own home. Going into his garden with his children, he touched certain tiny packages, prepared for the occasion, with bird-lime. Upon these were written, in minute handwriting, certain messages from his two little girls. The packages consisted of the thinnest of paper fastened with the thinnest of thread, and done up in the smallest parcels possible.

Releasing the bees, one by one, from the pasteboard box in which they had been imprisoned, he fastened with a trained hand each of the little packets to the back of a bee, which he then allowed to fly away.

Like homing pigeons, they started off at once across the unfamiliar desert for their home, arriving there in an incredibly short space of time with their packages secure upon their backs.

While at first sight it must be confessed that the employment of bees as couriers may seem something like a joke, it appears to have been regarded quite seriously in England. Military despatches, it was said, might be carried safely by bees in cases where birds could not escape a vigilant enemy, their small size rendering them practically invisible; and, if not snapped up by birds or by hornets, they could doubtless be relied upon to deliver safely the despatches with which they had been intrusted.

It must be added, however, that the use of bees for this purpose would, in a measure, be restricted to clear weather, when a strong wind is not blowing nor heavy showers likely to take place.

Early in June of this year experiments were made in Connecticut by Dr. Edward F. Bigelow

and Mr. L. C. Root, a bee-keeper of national reputation. In the first experiment the bees failed to return to the hive; or, if they did return, they could not be distinguished from the other bees. Of the second experiment, Dr. Bigelow writes as follows:

"We made careful tests, releasing bees at three different distances, from one mile to about two, on two different trips. Mr. Root had his horse and carriage for taking the bees away. We spent about half a day in experimenting with them, and the result was a success. The bees came in. We used flour mostly to mark them so that we could identify them, but also some blue diamond-dye powder. It would be



"HE FASTENED WITH A TRAINED HAND EACH OF THE LITTLE PACKETS TO THE BACK OF A BEE."

possible to send messages by different colors. One very interesting fact was developed. Out of one lot, some of the bees took in a load before they came home! Economy of time, they doubtless thought. They were combining business with pleasure! They were gone about a half-hour from the time they were released at a spot about a mile distant from the hive; and they came in with heavy loads of pollen on their legs."

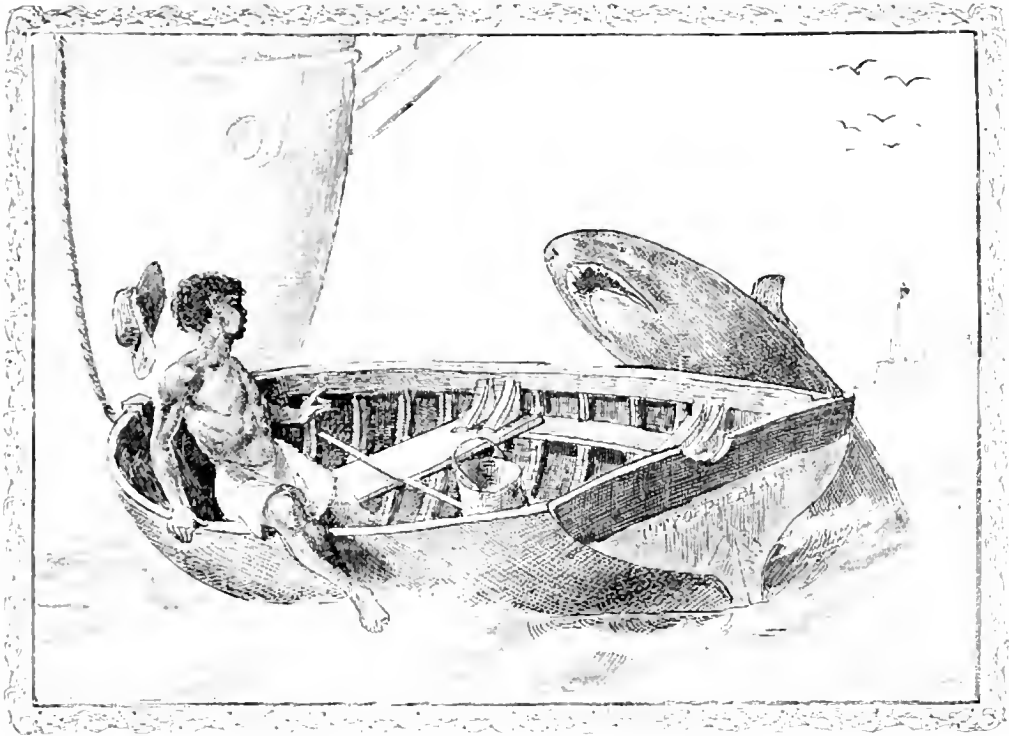

A NARROW ESCAPE.

BY H. A. JOHNSON.

THU yellow fever was raging in the city of Vera Cruz that year, and one of the large West-Indian liners which arrived on a certain day was obliged to anchor off in the harbor. A small boat, known as a dinghy, floated astern, and in this an active young colored boy of about fifteen was busily at work washing off the seats. The boat lurched over with a sudden dip as the boy bore his weight on one of the thwarts, and Pedro heard a warning shout from the steamer's deck just in time to give one terrified glance around, and to hear a noise he knew only too well.

Without an instant's hesitation he jumped overboard from the opposite side of the boat. For as he looked he caught sight of the jaws of a great shark which, spying this tempting morsel of a plump little darky boy, had leaped

toward the careened boat with open mouth. So vigorous was the shark's leap, that as Pedro went over on one side of the boat the shark flopped in on the other. Not being used to these surroundings, and missing his prey, he floundered around until his head bore down the gunwale, and he slid from the careening boat into the sea again before the people on the steamer could fling a harpoon at him. Almost as he disappeared poor Pedro's head popped up on the opposite side of the boat, and in a terrible fright he clambered into the dinghy again, as thoroughly scared a young darky as ever had a narrow escape.

Had he not thus saved himself from the man-eater, help from the steamer would have been necessary, and even then it is more than probable that the boy would not have been saved. This is a remarkable instance of the ferocity of a shark seeking his prey out of the water.

A NOCTURNAL SAILOR.

BY MEREDITH NUGENT.

THERE was n't a better sailor aboard than "Pete," and it was his first voyage too. As for climbing — why, he could do some tricks on the ship's ropes that made the sailors jealous with envy. But then these ignorant seamen would not have been so surprised at Pete's won-

thought of ever going to sea. During the day Pete slept comfortably in the wooden box just forward of the donkey-engine, as he had n't any fancy for daylight; but when glorious night came, with its magnificent setting of southern stars, Pete was more wide awake than anybody.

Then it was that he would climb the ship's rigging, and walk out to the ends of the swaying yard-arms; or work

his way up to the top of the tallest mast, and from this dizzy height look down at the sailors far below.

What a transformation all this must have been from the thick forests where Pete had been brought up! How strange the tall, smooth, leafless trees and taut climbing vines must have seemed to him! For undoubtedly he thought these masts and ropes somehow akin to the trees and vines of his tropic home.

When I visited Pete after his arrival in New York he was fast asleep; but as soon as the sailors learned that the readers of *St. NICHOLAS* would like to know how a clever little South American ant-eater had climbed the rigging, they woke him up, although it was broad day-

derful performances had they known that for years he had practised climbing on the great vines which hang in such amazing profusion from the trees of the tropical forests. Indeed Pete could hardly have selected a better school than those dense woods in which to fit himself for seamanship, although he probably never had the faintest idea of being captured, and still less

light, and set him on the steel-wire jib-stay that runs from the bowsprit to the foremast. Very reluctantly Pete climbed that slender rope to the yard-arm, and then slowly and deliberately returned to the deck, as though much annoyed at being disturbed in his slumbers. However, he had stayed aloft long enough for me to make a sketch of him, and here it is.



"VERY RELUCTANTLY PETE CLIMBED TO THE YARD-ARM."



FEEDING THE CHICKENS.

BY STELLA GEORGE STERN.

"WHAT shall we do this morning?" asked Papa Brown.

"I don't know!" said Bob.

"I don't know!" said Ben.

And "I don't know, indeed!" said Billy.

Billy liked to say "indeed," because mama said it.

I suppose you think that Bob and Ben and Billy were little boys. But they were not. They were little *girls*; and their papa called them boys' names for fun.

"Would you like to feed the chickens?" asked Papa Brown.

"Oh, yes!" said Bob.

"Oh, yes!" said Ben.

And "Oh, yes, indeed!" said Billy.

And then papa went to get the bread and water and corn. But when they reached the farm-yard, the little chicks were all around the coop, and acting very strangely. And what do you suppose was in the coop?

"It is the cat!" said Bob.

"It is the cat!" said Ben.

And "It is the cat, indeed!" said Billy.

Yes, there lay the brindled cat fast asleep! No wonder the little chicks were puzzled and frightened.

"Shall we wake her?" said papa.

"Oh, no!" said Bob.

"Oh, no!" said Ben.

And "Oh, no, indeed!" said Billy.

And they scattered the corn a few grains at a time, and drew the little chicks away from the coop.

And they fed the chicks, and the old hens laughed to see the little ones peck and the big ones gobble, and Bob and Ben and Billy clapped their hands and had a merry time. And they never waked the cat at all!

"That old rooster over there cannot hurt the little chicks, can he?" asked Papa Brown.



"Oh, no!" said Bob.

"Oh, no!" said Ben.

And "Oh, no, indeed!" said Billy.

THE HOLE IN THE CANNA-BED.

BY ISABEL GORDON CURTIS.

ONE evening in May, Chuckie Wuckie's papa finished setting out the plants in the front yard. Into one large bed he put a dozen fine cannas. They looked like fresh young shoots of corn. He told Chuckie Wuckie that when summer

"Much taller; as tall as I am."
Chuckie Wuckie listened gravely while papa told her she must be very careful about the canna-bed. She must not throw her ball into it, or dig there, or set a foot in the black, smooth

earth. She nodded her head solemnly, and made a faithful promise. Then she gathered up her tiny rake and hoe and spade, and carried them to the vine-covered shed to put beside her father's tools.

Next morning, when papa went to look at the canna-bed, he discovered close beside one of the largest plants a snug, round hole. It looked like a little nest. He found Chuckie Wuckie digging with an iron spoon in the ground beside the fence.

"Dearie," he said, "do you remember I told you, last night, that you must not dig in the canna-bed?"

"Yes," said the little girl.

"Come and see the hole I found there."

So Chuckie Wuckie trotted along at her father's heels. She



"PAPA TOLD HER SHE MUST BE VERY CAREFUL ABOUT THE CANNA-BED."

came they would grow tall, with great spreading leaves and beautiful red-and-yellow blossoms.

"Taller than me, papa?" asked the little girl, trying to imagine what they would look like.

stood watching him as he filled in the hole and smoothed down the earth.

"I did not dig it," said Chuckie Wuckie. "I just came and looked to see if the cannas had grown any through the night, but I did not dig."

"Really?" asked her papa, very gravely.

"Really and truly, I did not put my foot on there," said Chuckie Wuckie.

Papa did not say another word. But he could

"That hole again," said her father. "There's a stone in it now, is n't there?"

"No, that's what I thought; stoop down and look close, papa!" cried Chuckie Wuckie.

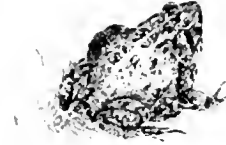

not help thinking that the hole looked as if the iron spoon had neatly scooped it out.

Next morning he found the hole dug there again, and Chuckie Wuckie was still busy in her corner by the fence. He did not speak of it, however. There were prints of small feet on the edge. He only smoothed down the earth and raked the bed. He did this for three mornings, then he led Chuckie Wuckie again to the canna-bed.

"Papa," she said earnestly, "I did not dig there. Truly, I did n't. The hole is there every morning. I found it to-day before you came out, but I did not dig it." There were tears in her brown eyes.

"I believe you, Chuckie Wuckie dear," said her father, earnestly.

That night the little girl stood at the gate, watching for her father to jump off the car. She could hardly wait for him to kiss her. She took his hand and led him to the canna-bed.

"Look!" she cried eagerly.

She was pointing excitedly to a hole beside the roots of a fresh, green canna plant.

It was the head of a fat hop-toad, but all that could be seen was its mouth and bright eyes. It was staring at them. Papa poked it with the point of his umbrella. It scrambled deeper into the hole, until there was nothing to be seen but the dirt. It was slowly changing to the color of the black earth.

"I watched him," cried Chuckie Wuckie, excitedly,— "oh, for an hour! When I found him he was just hopping on the canna-bed. He was looking for his house. He acted as if the door had been shut in his face. Then he began to open it. He crawled and scrambled round and round, and threw up the dirt, and poked and pushed. At last he had the hole made, just as it is every morning, and he crawled in. Then he lay and blinked at me."

"Clever fellow," said papa. "Well, we won't grudge him a home, and we won't shut the door again in his face, will we, Chuckie Wuckie?"

The cannas have grown very tall now, and so thick that you cannot see where the roots are; but a fat, brown hop-toad has a snug, cool, safe little nest there, and he gratefully crawls into it when the sun grows very hot.



NATURE AND SCIENCE

For Young Folks.

Edited by

Edward F. Bigelow.

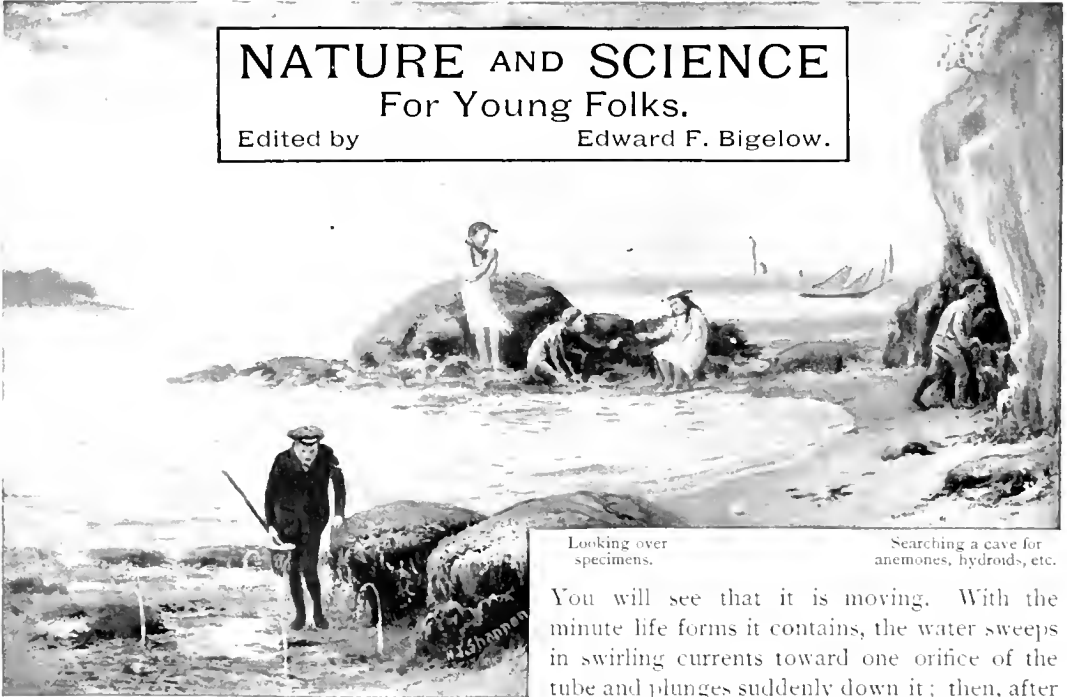

Watching the spurtings of soft clams.

Looking over specimens.

Searching a cave for anemones, hydroids, etc.

THE LIFE ALONG THE SEASHORE.

As we walk along the shore at low tide, on the lookout for seaweeds or interesting animals, little jets of sea-water will be seen spurting up from holes in the sand. Let us dig rapidly down under one of these tiny openings and we will catch the spurter, the common soft clam; but if we are not quick enough he will burrow so rapidly as to disappear entirely and only send a last spout of water into our faces, as if in defiance. Place the shell in a glass of sea-water, and when the clam gains confidence he will extend from his shell the long tube-like

You will see that it is moving. With the minute life forms it contains, the water sweeps in swirling currents toward one orifice of the tube and plunges suddenly down it; then, after passing over the gills and body of the clam and giving out nourishment, the water is expelled through the other tube, and we see it rising slowly from the opening. If, however, the clam takes a fancy to contract his shell and so hasten this motion, we will see a little fountain shoot up and sprinkle the surroundings, just as they were observed to do on the shore.

Be sure to look for the many worms that may be found, either in burrows in the sand or in tubes which they have built on rocks and stones.

All are interesting, and the forms and colorings of many are most



AN EGG-CASE OF THE SKATE

siphon, and the two openings in the end of it, with their fringed borders, will be seen. Now take a compound microscope or a magnifying-glass and watch the water above the siphon.

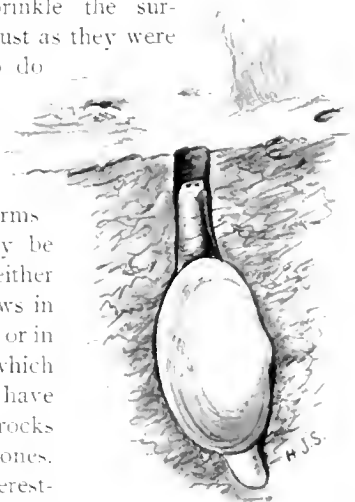

A SOFT CLAM BURIED IN THE MUD. The siphon extended above and the foot burrowing below.

beautiful, and their habits are remarkable. The sabella, one of the most interesting of the tube-

graceful motion, the worm allows the fringes of the filaments to gather a portion of mud from the sea-bottom, when, fingering and moulding it, the fringes carry it down the length of the filament to the bottom of the

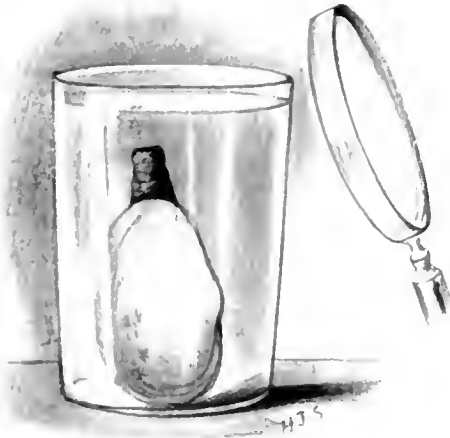

A CLAM PLACED IN A GLASS OF SEAWATER.

Currents of water being watched through a magnifying-glass.



THE WORMS SABELLA LIVING IN THEIR TUBES ON AN OYSTER. The worm at the right is not yet enclosed in the tube. There are some old and abandoned tubes on the upper part of the oyster-shell.

builders, may be found on rocks or shells in tubes of a parchment-like color built of sand and mud. From the end of the tube the worm extends a plummy crest of feather-like forms, which are the breathing-organs and are called gill-filaments. Each filament has two fringes of little tentacles extending along its length on the inner side, and these sensitive organs come into play when the tube is built. The process is wonderful. Bending down with slow and

funnel. Here it is given into the charge of two leaf-like organs on the neck of the worm, which place this building-material on the edge of the tube and shape it there, while at the same time a mucous secretion is given off by the worm which gives the mud cohesive power. When the action ceases, it will be seen that the tube is slightly lengthened.

One of the most interesting members of the crab family is the queer and grotesque little "fiddler" which lives in burrows in the banks of creeks and estuaries back of the beach. Into these burrows the crab retires in autumn and composes itself for a long winter sleep. The eye-stalks are then folded



TWO BLUE-CRABS FIGHTING.

Just in front of the crab coming toward us there is an anemone which has closed to protect itself. Expanded anemones are seen in the foreground at the left and on the rocks at the right. A hermit-crab and a shrimp are shown at the left.

down into sockets beneath the shell, and the large claw rests closed and inert against the body, while the legs are folded up until the entire animal is snugly closed upon itself, and it

lay their eggs in the warm sand in summer, and in August the little ones hatch out in great numbers, so

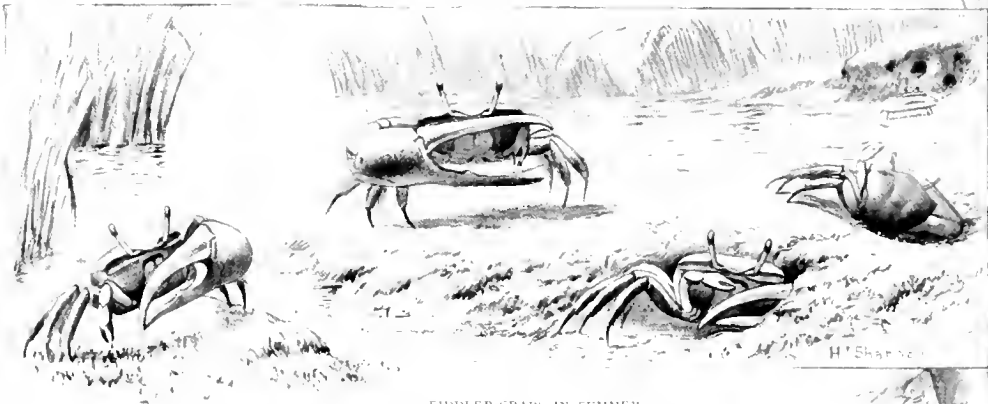

FIDDLER-CRABS IN SUMMER.

The one at the left is picking up food, while the one in the burrow is placing food in its mouth. At the extreme lower right a bank is shown as it appears in winter, cut through to show a crab hibernating in its burrow.

remains in this dormant condition until the spring. Early in April the fiddlers awaken, and immediately attend to clearing out their burrows. The large claw is useless for eating, only the small one being available for this purpose. It is amusing to see the delicacy with which this little claw feels about and picks up the particles of vegetable matter and places them in the mouth, while the eyes are all the time raised aloft on their stalks and apparently looking off into the distance. The female crabs have both claws small and of equal size, so they are both used in feeding, and she can satisfy her hunger just twice as easily and quickly as the male. These fiddler-crabs also gather food and store it in their burrows for future use.

Another queer crab is the *Limulus polyphemus*, or horseshoe-crab. These crabs

that in certain situations the shore is fairly alive with them. We may see them now, no larger than one's finger-nail, swimming actively about in the shallow water, or plowing the sand up before them with their queer little shovel-shaped heads.

They soon retire to deep water and live there with their parents, either on the sea-bottom or half buried in the mud and sand.

Great quantities of mussels are fastened all along banks and on the rocks. If we try to pull one away, we find it is securely fastened by a bundle of mooring-threads called the byssus. The mussel produces these threads at will when it finds a suitable situation; and although of apparent delicacy, these strands are very strong.

HOWARD J. SHANNON.



A HORSESHOE-CRAB BURROWING ON THE BEACH.

At the left some mussels are attached to the bank by their anchoring-threads.

A MONSTER FISH.

In the next column is shown a huge fish remarkable both on account of its size and its game qualities. It is known as the black sea-bass or California jewfish (*Stereolepis gigas*), and is found in moderate depths of the Pacific Ocean from the Farallones southward, being quite abundant in the kelp-beds about the islands off the coast. The one here shown was taken at Avalon, Santa Catalina Island, where anglers for large game-fish resort. The weight of the monster was four hundred and fifty-nine pounds. The fish is said to attain a weight of six hundred pounds or more. It feeds chiefly on other fishes, and, taken by hook and line, affords great sport for anglers. Heavy (25-ounce) 7½-foot rods of green-heart or split bamboo, large and well-constructed reels with a capacity of four hundred feet of No. 21 Irish-linen line, a 9-foot wire leader, and a 10-inch hook baited with several pounds of albacore, barracuda, or a live white-fish (*Caulolatilus*), are the tackle used by sportsmen. Rope, chain for leaders, and shark-hooks are used by the native hand-line or market fishermen.

The black sea-bass of California is one of the groupers, several of which grow to a weight of five hundred pounds or more (for example, the guaza, or spotted jewfish, and the black grouper).

Two notable specimens taken by rod and line weighed, one 419 and another 384 pounds. A photograph on the writer's table is entitled, "The World's Record Four Hours' Catch," by Dr. L.

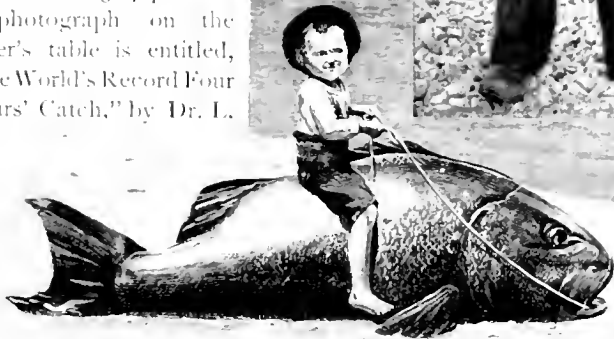

"A LITTLE FELLOW WAS PLACED ASTRIDE THE MONSTER AND PHOTOGRAPHED."

M. Taylor and H. St. A. Earlscliff, July 30, 1904, at Catalina Island. Five fish are shown, and the weights are 320, 280, 250, 170, and 130 pounds respectively.

B. A. BIAN.

Washington, D. C.

Mr. C. F. Holder writes us of a huge jewfish which he caught. It measured six feet in

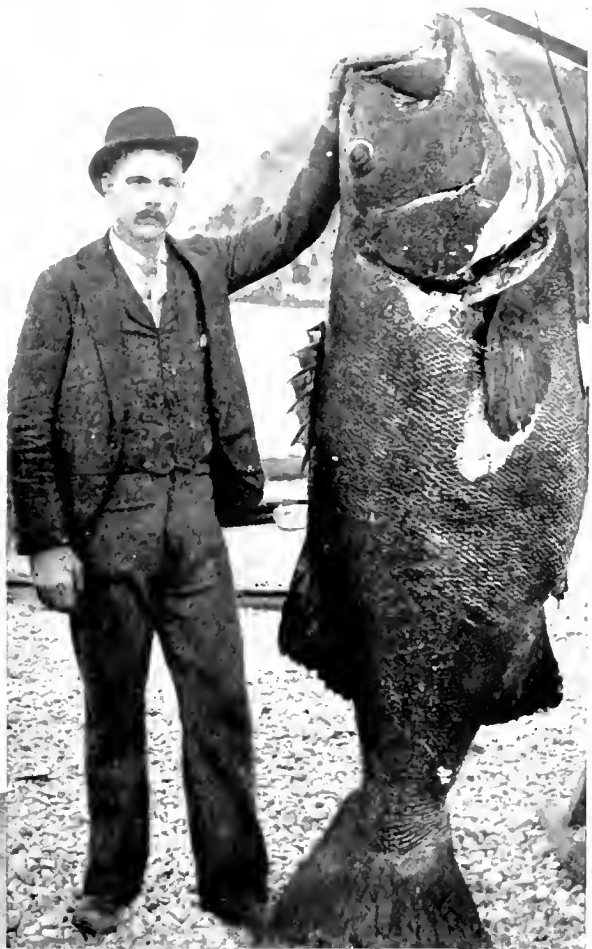

length and weighed three hundred pounds. He says:

"After we had beached the fish, a little fellow, who had been heard to say that he would like to ride a real jewfish, was placed astride the monster and was photographed.

WONDERFUL WORK BY SHELL-ANIMALS.

ONE of the most wonderful things Mother Nature does is to teach her children how to accomplish things with means and appliances that seem entirely inadequate for the purpose. A

bird will build an intricate and beautiful nest with no better tool than her beak (birds do not use their claws for this purpose); a

caterpillar can shape a symmetrical cocoon,

A certain sea-shell, *Lima hians*, shown in the illustration snugly ensconced in a dainty little nest of pretty, variegated, tiny shells and red coralline, not only swims about as freely as a butterfly flies,—though, as far as its form is concerned, a snuff-box would be apparently as well fitted to do so.—but actually builds the nest that it lives in, spinning a sort of net which binds the parts together, and this in spite of the fact that it has no eyes.

Another shell, *Pholas*, accomplishes something more wonderful—though this seems scarcely possible—than the *Lima hians*, for it actually works out nests or burrows for itself in the hardest sort of rocks, such as gneiss and granite. No one knows how this is done, for the material of the shell and of every part of the animal inside of the shell is, of course, much softer than the rocks into which it burrows. It is generally supposed that the creature works its way into the hard substances that it penetrates by means of what is called its foot, which is covered with a hard armor that is said to be renewed as soon as it is worn away.

As may be conjectured, however, it would take a very long time to make any sensible impression on the hard gneiss or granite with such an instrument.

So naturalists are not all of one mind about the matter. The only certainty is that Mother Nature teaches the *Pholas* to do this marvelous thing with appliances that seem utterly inadequate to the task.

The *Pholas* is shown at the bottom of the illustration on this page, safe within its rocky "nest"; at the

"NESTS" BUILT BY SHELL-FISH
Phosphorescent *Limas* "flying" through
the water as butterflies through the air.

and bees the sharp-angled cells of their combs. These are familiar instances of this, but by no means as wonderful as those shown in the work of some sea-animals that live in shells.

Pholas excavating burrows in rocks.

top, in the circle, are to be seen the *Limas*, fluttering about like moths in the dark. They are phosphorescent, however, and give out a light of their own, as do fireflies.

B. C. J.

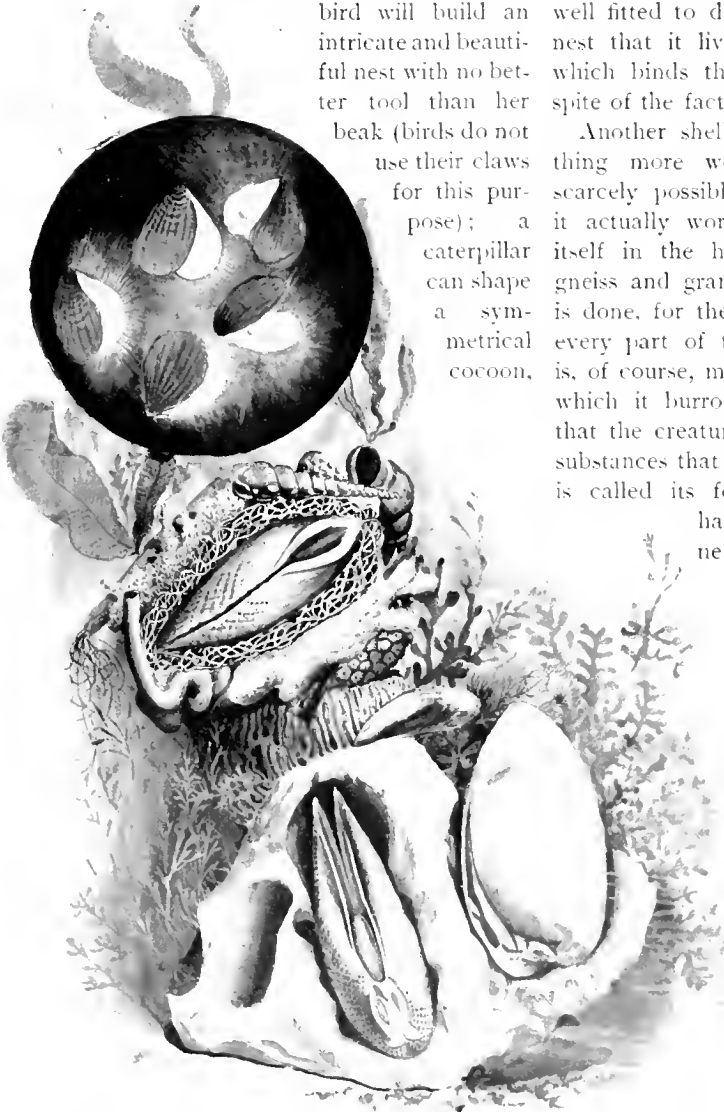

A COWBIRD EGG IN BLUE-WINGED WARBLER NEST.

On the ground at the root of a poplar-tree that had sprung up in a pasture beside the woods, a pair of blue-winged warblers had made their nest.



THE COWBIRD

A cowbird, in her suit of brown, came along that way one June morning. She seemed to have an object in view as

she disappeared among the leaves.

I could not tell what she was thinking, but it must have been something like this: "What a pretty nest! Plenty of room for another egg. Suppose I place one of mine there—who will be the wiser? What a fine thing to let some one else rear my bird, feed him when he is hungry, brood him through the cold nights, and, when grown, teach him to fly!"

So she laid an egg there, and, peeping from under the leaves to see that no one was near, she darted like a shadow into the woods and



A NEST OF A BLUE-WINGED WARBLER WITH FOUR EGGS AND A COWBIRD'S EGG.

The nest was very near the ground in a young poplar in an open pasture one hundred feet from the edge of the woods. The nest of dry leaves was externally lined with fine strips of bark.

down the ravine that leads to the brook where the thrushes, vireos, and warblers were flitting

and singing. She made no long tarrying with them, however, but soon flew over the hill and across the fields, and dropped, at last, into a flock of her own kind that were feeding among the cows in the meadow.

THOMAS H. JACKSON.

A "SUNRISE" PHOTOGRAPH.

WHAT I call my sunrise photograph was taken at "Fern Rock," Brookside, West Virginia, one morning in July. As I looked out



"THE PICTURE MAKES ME THINK OF A BOMB-SHELL BURSTING AMONG THE TREES."

of the window, the sun was trying to peer through a heavy fog, and I knew that I had a chance to get a fine picture, so out came the camera, and the photograph was quickly taken. I was not disappointed in the result. The trees appeared in strong relief amid the bank of mist, and "old Sol," like a huge morning star, came forth as a conqueror.

The picture makes me think of a bomb-shell bursting among the trees in the evening twilight. It is a snap-shot made in the one-hundredth part of a second.

HARRY B. BRADFORD.

"BECAUSE WE WANT TO KNOW" St. Nicholas Union Square, New York

????????????????

THE SCARLET Tanager WANTS TO KNOW.

THE birds and four-footed animals are nearly if not quite as eager to know about you as you about them. Watch their attitude of curiosity as they peer down at

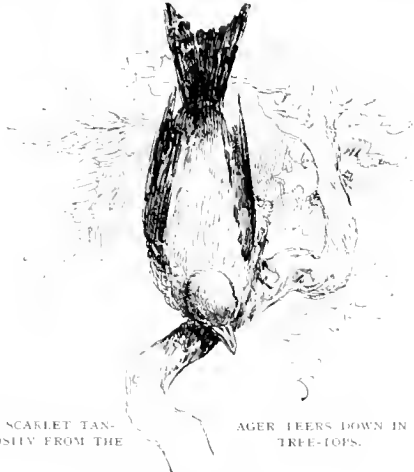

THE SCARLET TANGER CURIOUSLY FROM THE

AGER PEERS DOWN IN TREE-TOPS.

you from the tree-tops, especially if you make some queer sound like kissing the back of your hand—a favorite method of some naturalists of exciting animal curiosity.

CICADA GETTING OUT OF THE SHELL.

WETHERSFIELD, CONN.

DEAR ST. NICHOLAS: When we first saw the cicada he was just as he came up out of the ground. He kept climbing up the tree until he was ready to come out. Then he split the shell on his back. Then his back humped out, and soon his head and eyes came out. He kept leaning over backward until his head hung down a little. As he was going over backward, his legs came out, two by two. When about four legs were out, we saw some

little white threads which were fastened on him break. At first his wings were all crimped and folded up tight. Then it was fun to watch the wings unfold. He looked as if he would fall on his head. On the end of his tail we noticed that there



THE CICADA. (Improperly called "locust")

was a kind of hook that keeps him in so firmly. When the wings are almost straight, he throws him-

self up on the shell, and then crawls off on the tree, where he hangs until his wings are strong enough to fly.

HARRIET LORD BARSTOW (age 9).

The cicada is often incorrectly called "locust"—a term which should be applied only to grasshoppers. The cicada is a peculiarly interesting insect in that it has the longest life-period of any known insect. Some

kinds live even seventeen years, and are known as the seventeen-year cicada.



CICADA COMING OUT OF ITS SHELL

THE SO-CALLED "STING" OF CICADA.

ELICOLF CITY, MD.

DEAR ST. NICHOLAS: Having heard some persons say cicadas sting and others say they do not, I have decided to write and ask you, as I would like to know. Where is their stinger, if they have one, and is the sting fatal? I am of the opinion that they do not sting, as I have caught a great many and have never observed a stinger or been stung by one. But of course that is only my opinion. I knew, though, that if I wrote and asked you, you would be sure to tell me.

Your devoted and interested reader,

LAURA LAURENSEN BYRNE (age 12).

Newspapers very frequently report that human beings have been stung by cicadas. It would be possible for the periodical cicada to pierce the flesh with its sucking-beak or its ovipositor (egg-placer), or so-called "sting," but such occurrences, so far as known to scientists, are extremely rare.

Dr. Smith spent



CICADA LEAVING HIS OLD SHELL

much labor in carefully investigating such accounts, and found in every case that he followed up, where death had been reported as caused by the "bite" or sting of the "locusts," the story to be entirely fabulous.

Professor Potter, referring to the cicada, says in this connection: "It cannot defend itself against an ant or a fly. We have handled them, male and female, time after time. We have worried them in every way, but never could provoke resentment."

Professor Riley says that of the thousands and thousands of insects which he has handled, and the hundreds of other persons, including children, who have also handled these insects, not a single bona-fide case of stinging has, to his knowledge, resulted.

PINE-TREE LIZARDS.

WILMINGTON, DEL.

DEAR ST. NICHOLAS: I am sending you a photograph of myself with pet lizards. The lizard has a long body, four legs, and a tail. The tail will come off if the lizard is caught by it, and another will grow on again. These lizards live on the trunks of trees and on fences. Those in my picture were caught on the fence rails on grandpa's farm in West Virginia. Those lizards are harmless, and I was not afraid of them. Lizards eat grasshoppers, bugs, and roaches.

Yours truly,

ARTHUR F. SPAID (age 6).

This lizard is most commonly known as the fence-swift. Its technical name is *Tecloporus undulatus*. The species is found generally in the southern half of the United States, from the Atlantic to the Pacific coast. With the exception of the "chameleon," *Anolis carolinensis*, it is the most abundant lizard in this country—particularly in the East. Its food consists of insects. Male specimens may us-

ually be distinguished by brilliant blue spots on the throat and under side.

RAYMOND L. DEEMARS.

Master Spaid's father is the superintendent of the public schools of New Castle County, Delaware. Upon writing him, I found that he had published this photograph with an article

THE SUCKING-BEAR OF THE CICADA.



At the right and left are cicadas that have emerged; in the center is an empty shell.

the illustration.) In the article Mr. Spaid wrote as follows:

If there is anything we need to teach more than another, it is that numerous insects and reptiles, which are held by many persons to be poisonous, are perfectly harmless. This is especially so of the pine-tree lizard, or, as it is often called, the fence-lizard.

I know of nothing else so easily tamed. When caught in the hand, they seldom attempt to escape. Placed on one's clothing, they often sit in the same position for a long time. Knowing this peculiarity, I decorated my little son with nineteen lizards, just to prove to some skeptical people that I was willing to back up my assertions with a demonstration. Yet one observer who witnessed it declared that it was a risky thing to do.



PINE-TREE LIZARDS AS PETS.

THE ST. NICHOLAS LEAGUE.

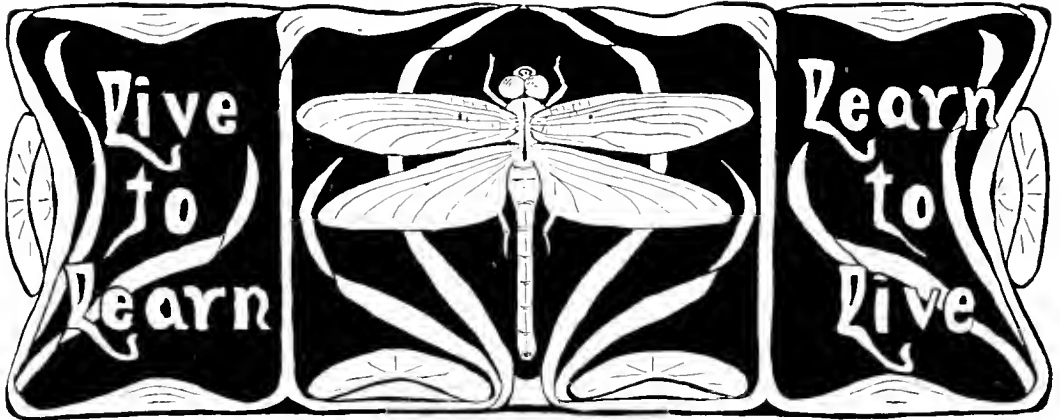

"A HEADING FOR AUGUST." BY CHARLOTTE WAUGH, AGE 15. (GOLD BADGE.)

THE WAVES.

BY HELEN COPELAND COOMBS (AGE 13).

(Gold Badge.)

I LOVE to listen to the waves
That softly lap upon the shore;
And farther out, along the rocks,
I love to hear the breakers roar.

I love to see the white-caps dance
Upon a blue and sparkling bay,
Or hear the fog-horn blow, perchance,
To signal wandering ships away.

I love to feel the cold salt breeze
That blows my tumbled hair about;
And when the boats are coming in
I love to hear the sailors shout.

The sea has always been my friend:
The waves that dash in foam and spray
Seem calling me upon the sand
As I am writing this to-day.

At intervals of now and then, perhaps because we have so many new members, it becomes necessary to set certain of our Leaguers right on the question of rules. There are signs that the time has come to do this once more.

For one thing, a good many contributors in this August competition sent poems, stories, etc., on the subjects given for June and July. Now if our new members (and some of our old ones) will look carefully, they will see that with each month the subject changes; and if it happens occasionally that we print something on the subject of the month before, it is because such contributions were previously accepted and left over for want of room, and not because we accept contributions on old subjects—unless, as happens sometimes, the old subject is repeated and so becomes a new one.

Then there is another thing: "photographs of wild animals and birds in their native homes" cannot be considered when the wild creatures are taken in an inclosure or private park. The object of this competition is to encourage the pursuit of animals and birds with the camera instead of a gun, and any creature in any sort of captivity, however wide may be its range, does not come within the rules. The animals of Yellowstone Park, though protected, come and go at free will, and photographs of these have been accepted, and have sometimes been prize-winners. But no protected range smaller



"THE PLAYGROUND." BY IRENE MERSEREAU, AGE 17. (GOLD BADGE.)



"THE PLAYGROUND." BY LYRA HOGGHELLING CANFIELD,
AGE 7. (SILVER BADGE.)

or with less freedom than the Yellowstone can be regarded in the light of a wild animal's native home.

It seems hardly necessary to say that it is useless to send photographs of *pictures* of wild animals. Yet, strange to say, these are offered in competition now and then. A young man of fourteen, from California, this very month sent a photograph of three deer taken from an "after Landseer" chromo or engraving. What is still more strange, the photograph is indorsed as having been "taken directly from the animals in their natural home," and this is signed by—well, we will reserve names this time, but it was not by either of the young man's parents. If the two young men who signed and sent this picture would reflect for a few moments, or even for half that long, they would realize that any one selected to edit the League would be employed, for one thing, for the very reason that he could tell the difference between a photograph and a chromo. It is not much of a qualification, either, but it's one he has to have to hold his place. He had it when he began the League six years ago, and the accomplishment has not been allowed to rust for want of practice. Besides, boys, even if you had succeeded, what is a prize worth if it is not won by real effort and fair means?



"THE PLAYGROUND." BY THEOBALD FORSTALL, AGE 11. (SILVER BADGE.)

PRIZE-WINNERS, COMPETITION No. 68.

In making awards, contributors' ages are considered.

Verse. Gold badges, Margaret Stuart Browne (age 15), Glendon, Devonshire Place, Eastbourne, England; Helen Copeland Coombs (age 13), 414 Liberty St., Warren, Pa.; and Kathryn Lewis (age 13), 55 W. 68th St., N. Y. City.

Silver badges, Hazel L. Raybold (age 15), 125 Tobey St., Providence, R. I.; Aileen Hyland (age 12), 500 E. D. Hyland, Inglewood, Station I., San Francisco, Calif.; and Phyllis Sargent (age 11), Graeme's Dyke, Berkhamstead, England.

Prose. Gold badges, Carl Philippi (age 11), 168 Beach Ave., N. Y. City, and Marta Cardenal y Pujals (age 13), Pasaje Mercader 7 y 6, Barcelona, Spain.

Silver badges, Paul Vallé, Jr. (age 11), 60 Brown, Shipley & Co., 123 Pall Mall, London, England, and Judith S. Russell (age 10), 145 W. 97th St., N. Y. City.

Drawing. Gold badges, Charlotte Waugh (age 15), 144 W. Robie St., St. Paul, Minn., and Richard A. Reddy (age 17), New Brighton, Staten Island.



"THE PLAYGROUND." BY LEWIS WALLACE, JR., AGE 13. (SILVER BADGE.)

Silver badges, Marion H. Tuthill (age 16), 1084 Bedford Ave., Brooklyn, N. Y.; Ben Roth (age 15), Columbus, Ind.; and Anne Duryea (age 10), Palo Alto, Cal.

Photography. Gold badge, Irene Mersereau (age 17), 99 N. Marengo Ave., Pasadena, Cal.

Silver badges, Lewis Wallace, Jr. (age 13), 1260 N. Meridian St., Indianapolis, Ind.; Theobald Forstall (age 11), Montclair, N. J.; and Laura Houghteling Canfield (age 7), Mrs. Cass Canfield, Roslyn, L. I.

Wild Animal and Bird Photography. Cash prize, "Least Flycatcher," by Dunton Hamlin (age 16), Box 82, Orono, Me. Second prize, "Wild Turkeys," by Mildred Armour (age 14), 1668 Ridge Ave., Evanston, Ill. Third prize, "Turtle," by Donald Armour (age 12), above address.

Puzzle-making. Gold badges, Helen Semple (age 15), Morgan, Harjes & Co., Paris, France, and Russell S. Reynolds (age 14), 142 W. 12th St., N. Y. City.



"A HEADING FOR AUGUST." BY RICHARD A. REDDY,
AGE 17. (GOLD BADGE.)

Silver badges, **Virginia Livingston Hunt** (age 14), 273 South St., Morristown, N. J., and **Corinne J. Reinheimer** (age 13), 127 E. 72d St., N. Y. City.

Puzzle-answers. Gold badges, **Edmund Willis Whited** (age 15), 286 Main St., Pittsburg, Pa.; **John B. Hollister** (age 14), 1819 Madison Road, Cincinnati, Ohio; and **Louis Stix Weiss** (age 11), Depot Lane, Fort Washington, N. Y. City.

Silver badges, **Margaret Greenshields** (age 13), 53 Simpson St., Montreal, Quebec; **William H. Bartlett** (age 10), Hampton Falls, N. H.; and **Helen L. Patch** (age 9), Berkshire, Tioga Co., N. Y.

THE SONG OF THE WAVES.

BY MARGARET STUART BROWNE (AGE 15).

(Gold Badge.)

PROUD and free, fierce and bold,
Whom neither chains nor walls can hold,
We laugh and mock at the sailors' pale,
Who cower as we pipe in the yelling gale,
And, clinging hard to a shattered rail,
Face death in the waters cold.

We can fight and wrestle where
Foam-wreaths shatter and wind-horns blare;
We can dance to a merry tune

With gentle feet where the ripples croon,
And white arms raised to the tranquil moon
That silvers our streaming hair.

Man may boast of his steeds of steel,
With red-hot eyes, and with clanking wheel;
He at a frantic pace can ride
Where tangled seaweed and coral bide,
And, singing, we can race beside
The steamer's heavy keel.

And if we tire of this din and stir,
And of stormy skies which fog-banks blur,
He can sleep in a sunny bay
Where pink shells lie and children play,—
Where, on quiet waters, walks blue-clad Day,
Her cloud-sons leading her.

FUNNY WHEN IT WAS OVER.

BY MARTA CARDENAL Y PUJALS (AGE 13).

(Gold Badge.)

THE funniest incident I know about happened in a town in Spain. A lady once went for a walk in one of the principal streets of the town, with a little girl nine years old, and also a fox-terrier which both of them loved dearly. It happened to be in spring, when the dog-catchers seize all the dogs that they see without a muzzle, because it is dangerous to be bitten by them.

This lady had her dog following her without a strap or muzzle, so the dog-catchers caught it. When she and the little girl saw their dog had disappeared, they began to weep. They told the dog-catchers they would pay however much they asked, if they would only return them their dog. The men could not give the dog back until it had been at least one night with them.

When they saw they could not have it, they determined not to leave it, but to follow the cart. So they followed it until dusk; the lady and the little girl crying bitterly, and the dog howling and barking inside the cart.

On arriving at the place where the cart was to stop, one of the officials said they could only have it restored to them if they went to the town hall and asked a card from the mayor. With that, and by paying a dollar, the dog would at once be given back to them.

On the way to the town hall they discovered they had not as much as a dollar in their purse. When they arrived there the policeman said it was too late. When they heard the news they began to cry again, until the policeman, on seeing their sorrow, took compassion and lent the required money and gave the card. They then went back to the dog-catcher's house, and after having given the money and the card they carried the dog home in triumph, where the whole tale was related and laughed over by the rest of the family.

THE WAVE.

BY KATHRYN LEWIS (AGE 13).

(Gold Badge.)

I AM the Wave of Life,
Stained with my margin's dust;
From the struggle and the strife
Of the narrow stream I fly
To the sea's immensity,
To wash from me the grime
Of the muddy banks of Time.

A FUNNY INCIDENT.

BY CARL PHILIP (AGE 11).

(G. of Badge.)

LAST winter, when the snow and ice covered the ground and it was frozen hard, a favorite cat died in the household of Mr. R—, a suburban resident of New York City. There was no possibility of burying the animal in the hard ground. So Mrs. R— put the cat in a neat little package and gave it to her husband to throw in the Hudson River as he crossed on his way to New York. Mr. R— absent-mindedly forgot to throw the cat overboard, and reached the office with the parcel in his hand.

He decided to keep the package until evening and to dispose of it on the way home. On his return home, he met several of his friends on the ferry and became interested in their conversation. Before he knew it, he was on the train with the parcel still in his possession.

Mr. R—, being a very particular man, decided to take it home again and try over the next day.

He placed the parcel in the receiver overhead. Soon he reached his destination and started to leave the train. Just as he was stepping off the train he remembered his bundle, and had barely enough time to get it.

He soon reached home and told his wife what had happened. She looked at the bundle and said:

"Why, that is not the one I gave you this morning!"

She took it into the kitchen to examine more closely, and, to her great surprise, found that the paper contained a fine roast beef.

Imagine the still greater surprise of the other man!

MY HOME BESIDE THE WAVES.

BY AILEEN HYLAND (AGE 12).

(Silver Badge.)

I HAVE the sweetest home on earth,
Right here beside the sea;
Where I can watch the wild waves dance,
So restless and so free,
Of all the homes in this wide world,
None could so well suit me.

I love to watch the roaring waves
As they come tumbling in,
And catch the funny jellyfish,
So round and flat and thin;
I love to dig down in the sand,
And hunt for terrapin.

I see the gulls skim o'er the waves,
And fly up in the air;
Sandpipers run across the beach,
And leave small footprints there.
I hunt for shells and odd seaweeds,
Which sometimes are quite rare.

What fun the mermaids ought to have
Among those waves all day!
But when the sea is clothed in mist,
On land I'd rather stay;
For it is cold at eventide
Down in these depths so gray.

A FUNNY INCIDENT.

BY PAUL VAHLE, JR. (AGE 11).

(Silver Badge.)

ONE day (I was about six years old) I started out hunting nests. Very soon I spied a robin's nest up in a tree about fifteen feet from the ground. Not having any robin's nest, I decided to try and get this one. No sooner said than done. I was up the tree, and had almost reached the nest, when, horror of horrors! my foot slipped and down I fell. Instead of falling to the ground as I expected, the seat of my trousers caught hold of a branch, and there I hung like a scarecrow without being able to release myself. I yelled and screamed and kicked a lot, but nobody heard me. How

long I stayed I did not know, but I do know that I had hardly any breath left in me when, luckily for me, the iceman made his appearance, and after quite a little trouble lifted me down and took me home.

My mother was waiting for me on the porch, and broke out laughing when she heard my story. She did not punish me as I deserved, but she told everybody about it, and by and by it got to the boys, who made a great deal of fun of me.



"A STUDY OF FOLIAGE." BY BEN ROTH, AGE 15. (SILVER BADGE.)

A TALE OF THE WAVES.

BY HAZEL I. RAYBOLD (AGE 15).

(Silver Badge.)

FAR out in the wondrous ocean
great a little wavelet grew;
She lived on sky and sunshine
sweet and seaweed wet with dew.
Her mother was a billow big, her
father was a swell;
They lived in high society, as any
fish could tell.
Their palace was the jeweled cave,
their maids the mermaids
green;

When they had other waves to dine it was a stirring
scene!
They fed their private fisheries with shells of every
shade,
And thus had shell-fish for each meal, and sponge-
cake, all home-made.
One day the wavelet, wand'ring, leaned upon a broad
sand bar,
And with a pensive, tearful eye gazed on the sea
afar;
And then a watery smile smiled she, more sweet than
I could say,
For from the grand Sea View Hotel the bell-buoy
looked her way.

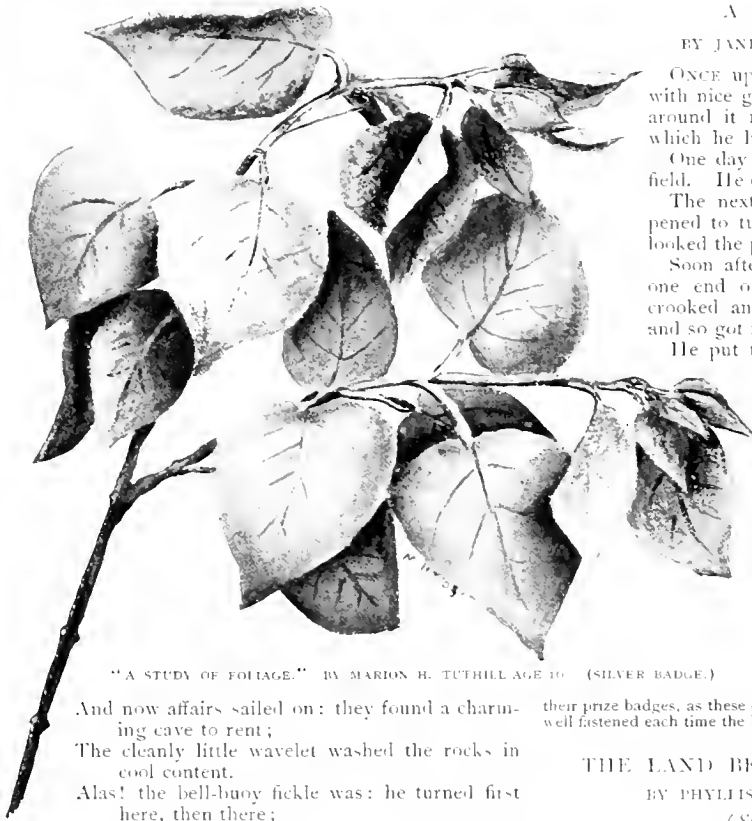

"A STUDY OF FOLIAGE." BY MARION H. TUTTILL, AGE 10. (SILVER BADGE.)

And now affairs sailed on: they found a charming cave to rent;
The cleanly little wavelet washed the rocks in cool content.

Alas! the bell-buoy fickle was: he turned first here, then there;

He craved for other conquests, and for old loves ceased to care.

He quoth: "I'm in deep water; 'time and tide wait for no man';

I 'll leave her once, forever,—'t is the only way I can."

The wavelet on the sand-bar saw he looked her way no more;

His gaze was always fastened on a shallop near the shore.

With grief the wavelet faded till she grew too thin for speech;

One day she ventured to the land, and died upon the beach.

A FUNNY INCIDENT.

BY JUDITH S. RUSSELL (AGE 10).

(Silver Badge.)

IN a lower East Side school, a teacher sent a boy out to see the time. She had just been giving a lesson about leaving off the "g's" at the end of words ending in "ing." When the boy came back she asked him what time it was.

The boy, instead of saying five minutes to three, said: "Teacher, in five minutes we 're goin' home."

The teacher then said: "Johnny, where is your 'g'?"

Johnny promptly answered: "Gee, teacher, in five minutes we 're goin' home."

Lost or damaged League badges will be replaced free of charge

A FUNNY INCIDENT.

BY JANET E. STEVENSON (AGE 10).

ONCE upon a time a farmer had a field with nice green grass in it; he had a fence around it made of logs to keep the pigs which he had on his farm out.

One day he found one of his pigs in the field. He could not imagine how it got in.

The next day he watched, and he happened to turn his head away, and when he looked the pig was not there.

Soon after he found that the pig got in one end of one of the logs, which was crooked and hollow, and crawled through and so got into the field.

He put the log in such a way that both ends came out at the same field, so if the pig went in one way it would come to the same field.

He watched, and soon the pig crawled in the log. When it came out the other end into the same field it could not understand what it meant. It looked around in the most disgusted way and walked off.

It never tried to enter the field in that way again.

NOTICE.

Members should be very careful of their prize badges, as these cannot be replaced. See that the pin is well fastened each time the badge is worn.

THE LAND BENEATH THE WAVES.

BY PHYLIS SARGENT (AGE 11).

(Silver Badge.)

I LONG to see the land beneath the waves,

Where all the wonderful sea-people dwell,
Who live far down in lovely coral caves—

I look for them while angry billows swell;

I sit and watch where every wave has rolled,

To know the pathway to their ocean home;

Sometimes I think there is a gleam of gold—

But no, it is the seaweed in the foam.



"LEAST FLYCATCHER" BY DUNTON HAMLIN, AGE 10. (CASH PRIZE, "WILD-BIRD PHOTOGRAPH.")

I often dream at night of mermaids fair,
 Who, when we all are sleeping, softly rise
 And dance in circles 'mid the breakers there,
 Until the sun appears in eastern skies,
 When ships come in from waters deep and green,
 With white sails flapping in the summer breeze,
 I think of everything they must have seen
 If they have viewed the land beneath the seas.

A FUNNY INCIDENT.

BY EDITH M. ANDREWS (AGE 17).

ON Labor Day, 1904, I witnessed one of the funniest incidents I have ever seen.

It occurred in Niagara-on-the-Lake, Ontario, Canada, at the Queen's Royal Hotel. Labor Day was celebrated by holding gymkhana races in the afternoon. The last race of all was the "Animal Race." Young ladies each chose an animal; they started at one end of the tennis-courts and went to the other end; the animal from which they chose were pigs, geese, chickens, and rabbits. No dogs were allowed to enter this event.



"TURTLE." BY DONALD ARMOUR, AGE 12. (THIRD PRIZE, "WILD-ANIMAL PHOTOGRAPH.")

After much confusion and laughter, the young ladies managed to get their charges in line, and they started off for the other end. People cheered, pigs squealed, geese squawked, chickens flew wildly about, and rabbits refused to move. Really, I don't think I ever laughed so much in my life before. To see the way the girls shoved the poor little birds and beasts to make them go was a sight never to be forgotten. Of course no one was allowed to pull an animal; one could only tap it with a twig and yell at it. Miss F — won, having driven a pig which grew so scared at all the noise that it dashed forward from time to time, until it reached the goal. I do not know what the prizes were, but I do know that they were very well earned.

THE LAND BEYOND THE WAVES.

BY MARGUERITE STUART (AGE 17).

BEYOND the waves that sometimes, deeply blue,
 Come rippling toward the sands upon the beach,
 And sometimes, gray, with foamy white-caps decked,
 Defy and warn who comes within their reach,
 There lies a sunny land, that seems to be
 Enticing, siren-like, across the sea.

There lie wide, waving fields of golden grain;
 There warbling brooks flow down the mountain-side;



"WILD TURKEYS." BY MILDRED ASMOUD, AGE 14. (SECOND PRIZE, "WILD-BIRD PHOTOGRAPH.")

While nestling close among encircling hills
 The homes of peace and happiness abide,
 And all the ripples seem to sing to me:
 "An ideal land lies yonder, o'er the sea."

There also lies a forest, still as death—
 Except, indeed, the song of some stray bird
 Or sighing of the wind among the pines,
 There never sound of discord may be heard.
 And this is what the white-caps tell to me:
 "A land of perfect peace lies o'er the sea."

Oh, why is something unattainable
 The thing our hearts seem always to require?
 Why does the land that lies beyond the waves
 Forever seem the height of our desire?
 "The secret," said the laughing waves to me,
 "Is as unfathomable as the sea."

A FUNNY INCIDENT.

BY MILDRED C. JONES (AGE 16).

ONE morning, when my brother Almon was a little boy, we were preparing to go to a party. Almon was happy playing and thinking of the fine time in view, when mama told him he must go to the barber's first.

Now before mama had always cut his hair, and he strongly objected—indeed, was afraid to visit the shop where the scissors were used.

However, he at last decided to make a trial, and crossed the street with his mother; but one look in the window was enough, and he fled home in spite of his mother's warnings that he would have to stay home. She said he was too big a boy to have his mother cut his hair any longer, and if he was ever going to be a man, like papa, he'd better begin to go to the barber's. Almon at last surrendered to such reasoning, somewhat ashamed of himself, and this time was seated in the barber's chair; but at the first touch of the shears he jumped up terrified and raced for home. Mama declared she would have nothing more to do with him, and he might stay home if he wished. And a boy with a sad little face sat disconsolately in front of the barn door the rest of the morning.

Whenever he ventured to the house for comfort or to see whether his mother showed any signs of relenting or not, some one was sure to be talking about the party, and he sadly resumed his seat in the barn doorway.

After we had gone, auntie told Almon that if he would go to the barber's with her, she would take him to the party and also buy him a big bag of peanuts. The

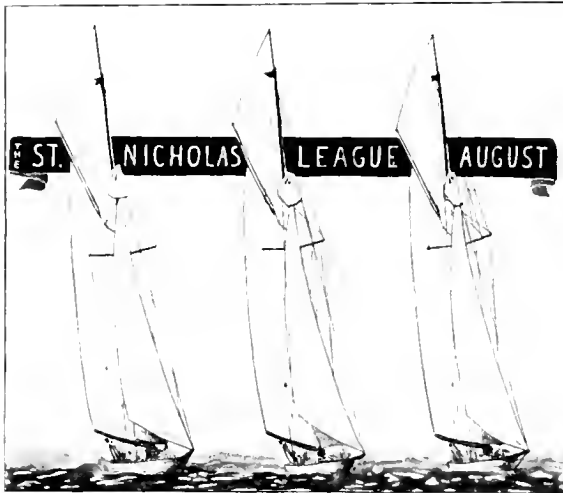

"A HEADING FOR AUGUST," BY E. F. ANDREWS, AGE 10.
(HONOR MEMBER.)

peanuts decided the day. Seated in the chair, with teeth clenched and hands tightly grasping auntie's purse, he had his first real hair-cut, which truly was n't so dreadful, after all, when one had the prospect of peanuts.

In the middle of the afternoon, whom should we spy coming up the road with auntie but Almon. He had a broad grin on his face; and when they reached the gate he proudly took off his cap to notify all present that *he* was ready for the party.

THE SONG OF THE WAVES.

BY ELEANORE MYERS (AGE 15).

(Honor Member.)

"AWAKE! awake, O world of sleep!
We call to thee as on we leap;
Behold! Aurora's blushes bright
Flood all the eastern sky with
light—
Come, join us as we speed along,
And hear our rippling laugh and
song."
Thus sing the waves when morning
breaks
And all the slumbering world awakes.

But when 't is noon they plaintive
call,
As on the beach they rise and fall:
"Oh, come with us, ye mortals, pray,
And to the ocean deep away.
Behold! as far as ye can see,
The blue sea stretches temptingly."

But lo, as twilight dims the day
And night inwraps the world in gray,
Still sing the wavelets from the shore,
But they entreat and call no more.
A voice arises from the deep—
It whispers: "O ye mortals, sleep!
Through all the dark and misty night
We watch the white stars twinkling
bright;

For they and we our watch must keep,
But ye, O mortals, rest and sleep!"



"A HEADING FOR AUGUST"
BY MURIEL C. EVANS, AGE 17.
(HONOR MEMBER.)

A FUNNY, YET ALARMING INCIDENT.

BY MILDRED S. RIVES (AGE 11).

Two or three weeks ago I went to the Horse Fair, and there I saw a very funny thing, though it frightened me a good deal at the time. They had all sorts of performances: among them were cowboys racing and doing tricks. They had just let a steer into the ring, and all the cowboys tried to lasso him; but before they were able to catch him he dashed up the stairs that lead to the boxes, and, galloping into the musicians' stand, put them all to flight. The cowboys jumped off their horses and ran after the steer, and succeeded in capturing him just as he was nearing our box. Of course all the people scattered when they saw him come toward them.

I laughed till I cried when it was all over.

THE WAVES.

BY GRACE LESLIE JOHNSTON (AGE 12).

(Honor Member.)

MISS NANCY WHITE went out, one day,
With shovel bright and bucket gay,
And sitting down, with graces grand,
She then proceeded, with the sand,
To build, as finely as could be,
A little castle by the sea.

The waves crept up about her feet—
Miss Nancy quickly changed her seat;
They rippled o'er the glistening sand—
She hastily withdrew her hand;
And when she rested in her play,
They swept the castle quite away!

Miss Nancy grasped her shovel bright,
And gazed upon the direful sight.
But she had learned a lesson then,
And now, in age and wisdom,
when
To architecture she 'll repair,
She builds her castles in the air.

(NOT) A HERO.

BY DORIS FRANKLYN (AGE 17).

HE *would* have been a hero
If he had just known how!
He practised on the chickens,
The roosters, and the cow.
He charged them in the meadow,
Upon his wooden steed;
But when the cow came toward him,
He climbed the fence with speed!

And when a bee came buzzing
Around his curly head,
Bethought himself of running;
And straightway homeward fled.

He left the creatures laughing:
The old cow chuckled, "Moo!"
The ruffled roosters answered
A "cock-a-doodle-doo!"

That evening, after supper,
Safe by his mother's knee,
He heard the farm-yard "laughter,"
And knew the cause of glee.

"I will not be a hero,
And talked of when I'm dead!
I'd rather just be Georgie
On mother's lap," he said.

THE FAIRY BALL.

BY CHARLES IRISH PRESTON
(AGE 12).

LIGHTED by the firefly's glimmer
And the summer moon's pale
light,
By the mystic, winding river
There is revelry to-night.
Here, upon their reed-pipes play-
ing,
Are the tiny elfin band,
And upon a toad-stool sitting
Is the king of fairyland.
Guests arrive in dainty barges
Made of water-lily leaves;
For their sails are spread the cob-
webs
That the garden-spider weaves.
Merrily the hours are speeding,
See the gallants' swords shine
bright,
While the ladies through their
arches
Gaily trip with footsteps light.
But along the east horizon
Shows the faintest tinge of dawn,
And without a sign of warning
All the fairy troop are gone.



"THE PLAYGROUND" BY ALICE GARLAND,
AGE 14 (HONOR MEMBER.)

A FUNNY INCIDENT.

BY HELLN BLAIR (AGE 10).

AMONG the wedding guests, when my father and mother were married, was an old judge who was growing somewhat absent-minded and forgetful. After the ceremony was over the guests came up to congratulate the bride and groom.

The judge came up and shook hands with my mother. Then he turned to my father and said: "Beg pardon, what name, please?"

My father gave his name and concealed his amusement.

THE WAVES.

BY MARION MAIR (AGE 8).

THE waves were rushing at my feet,
That beautiful August day,
As I sat alone on my benchlike seat,
And watched the sea-gulls play.

I watched the sea-gulls soar on high,
Above the foaming waves;
The waves were colored like the sky,
And roared inside the caves.

But some did dash upon the shore,
And washed the sand away,
Until my bench was safe no more,
And so I did not stay.

A SONG TO THE WAVES.
BY MAUD DUBILEY SHACKLEFORD (AGE 16).

(Honor Member.)

BEAR me away on your breast, O Waves,
When the round of the day is done;
Carry me far in the golden west,
To the land of the sinking sun,

Where many a ship, with sails
afloat
In the flush of the crimson
light,
Has crossed the line and passed
beyond,
In the mist of the ocean's night.

Pillow my head on your current
strong
When the moon comes up from
the sea—
A fairy ship in the darkened
sky,
It rises, a beacon to me,

When 't is the time that the salty
winds
With the laughing mermaids
play,
As gems they pluck for their yel-
low hair,
From the crest of the moonlit
spray.

Drift me afar on the restless
tide,

As the bunches of seaweed float
On the silver path that is left behind
In the wake of my fairy boat.

Out with the wings that the breezes lend,
Till the lights that burn on the strand
Shall fade from sight as I near the shores
Of the far-away sunset land.



"THE PLAYGROUND" BY WAKREN ORDWAY, AGE 16. (HONOR MEMBER.)

WAVES.

BY ISADORE DOUGLAS (AGE 17).

(Honor Member.)

FROM somewhere out of the woods by the lane
 An idle wind wanders and touches the wheat;
 And where was but now a field of grain,
 A shimmering sea ripples out at my feet,
 Whose waves go eddying up the hill,
 Stray over the field—now here, now there,
 Then quicken, swayed by the mad wind's will.
 Race on to the fence where two fields meet,
 To break in a swirling of daisy-heads
 And the tossing spray of bittersweet.

THE MAGIC TOOLS.

BY ARNOLD H. RAFFMAN (AGE 11).

ONCE upon a time there lived a poor woman who, though she had many boys, had only one girl. She worked hard, but only earned enough to support herself and family in the poorest way. Her eldest son soon left her to search for "the Magic Tools." He had heard that any one who secured these would be famous the world over, for one would give him wisdom, one would grant any wish he might express, and a



BY ELISE R. RUSSELL, AGE 11

third would point out to him the person whom he was to marry. These were kept in a certain mountain, and were guarded by a dragon so fierce that no one, however brave, dared face him. They were kept in a gold chest, and the key the dragon had swallowed, so that it was a very hard task to perform. The young man reached the mountain and procured the weapons with which he was to slay the dragon. He then reached the chamber, which was black as night, and, looking round, saw the eyes of the fiery dragon gleaming like torches.

At first sight of the dragon the young man trembled; but as he stood gazing at the eyes he lost all fear, and, creeping up softly, struck a blow with all his might and then sprang nimbly behind a rock, for the dragon was in his death-throes. The dragon seized the rock behind which he was hiding, and hurled it at the boy; but it, missing him, fell on the golden chest, and immediately he vanished. The room became as bright as day, and the lid of the golden chest, instead of being smashed, stood wide open. A smaller box inside was also open. In it there was a small silver key, and tied to it was a paper which said:

"Search for the keyhole along the wall,
 Insert this key, and—that is all."

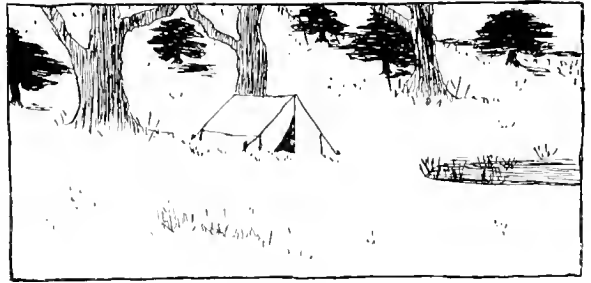

"A HEADING FOR AUGUST" BY ANNE DURVEA, AGE 10. (SILVER BADGE.)

The boy eagerly sprang up and looked round, but not a crack or hole did he see. At last the sunshine fell on a small hole. He ran to it, inserted the key, and—that was all; for he saw his quest, the Magic Tools.

He gazed at them at first with the greatest joy. Then came a shade of disappointment, for, instead of being bright gold set with diamonds, as he had imagined, they were of rusty iron.

He naturally reached out his hand, but he received such a sting that he drew it back hastily. Looking round, he observed a horn on which was inscribed:

"Blow a single blast on me,
 And you shall soon your treasure see."

Seizing it, he blew a shrill blast. The tools remained the same. He seized them, but they vanished. Much disappointed, he went out of the mountain and home. He told his mother his adventures, and that he had decided to stay at home with her. He went to his room to put on his working-clothes; but as he laid his coat down there was a heavy thump. He put his hand in his pocket and drew out—the Magic Tools!

After getting them in his possession we will hope that he lived happy ever after.

THE FAIRIES' DANCE.

BY LISA TALK (AGE 16).

WHEN twilight, like a misty veil,
 Drops softly over hill and dale,
 When proud the silvery moon so fair
 Mounts silently her throne of air,
 When lost in dreams lie wood and lake,
 'T is then the fairy folk awake!

From fairyland, the realm of dreams,
 O'er bridges built of moonlight beams,
 O'er paths upon the glassy lake,
 Through darksome glen and tangled brake,
 This fairy band from clifland go
 With footsteps light as falling snow.

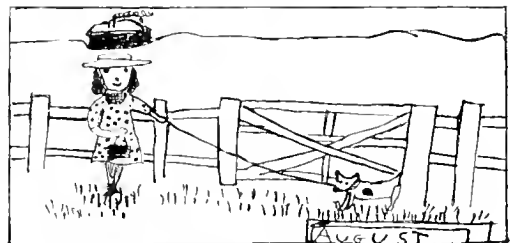

"A HEADING FOR AUGUST." BY BERYL MARGETSON, AGE 6.

In spots by mortal eyes ne'er seen,
Where mosses grow like carpets green,
Among the ferns and violets blue,
And blossoms fair of every hue,
Where glow-worms golden, fireflies bright,
Diffuse their tender misty light,—

There trip the gay and merry band
An airy dance of fairyland,
And whirl so lightly round and round,
Their twinkling feet scarce touch the ground—
Till, when the flush of dawn is seen,
They flee in clouds of golden sheen.

A DREAM OF THE FAIRIES.

BY MARY CLARA LUCKER (AGE 15).

(Honor Member.)

I SAT beside a streamlet, flowing peacefully along;
And as it flowed the murmuring waters sang to me a
song.

Now gay it was, now plaintive, so it lulled me far away
To the pleasant land of
slumber where the little
fairies stay.

Then all those fairy crea-
tures gathered round me
—so I dreamed;

And as I looked a count-
less, brilliant multitude it
seemed,

As if five thousand rain-
bows and a thousand stars
of light

Had blended all together to
dispel the gloom of night.

And then I asked, "Why
do you never come our
world to see?"

Why is it that you always
dwell in realms of fan-
tasy?"

Then spoke the queen of
all the rest, "We come
to earth each day,

Though some know not
that we are there, and
some turn us away.

"The sympathy that leads you to relieve another's
woe,

The love you give to others in the journey here be-
low,

The hope that makes you meet the hardships, loyal,
strong, and true,

The faith that makes you happy e'en when sorrow comes
to you,—

"Lo! what are these but fairies? Oft they come to
you in vain;

And if they are not welcomed they will never come
again."

Her voice became the rippling of the little woodland
stream,

When I awoke and realized that it was all a dream.

I think I learned a lesson on that lovely summer's day
As I sat there in the forest where the streamlet found
its way:

VOL. XXXII.—120.

The fairies come—if we but welcome them they'll ne'er
depart;
The pure and noble thoughts they are, enshrined within
the heart.

WHY THEY ARE CALLED PUSSY- WILLOWS.

BY HELEN EDGELL (AGE 11).

ONCE upon a time, when the world was very young,
there lived on the edge of a desert a great many little
pussy-cats.

Now, cats in those days could talk as well as we our-
selves can. These cats used to boast a great deal about
what they could do. When people passed by, the cats
would all begin to tell what they could do, although
they never did what they said.

At last the genie of the desert heard of this and made
up his mind to punish them. So he came to them and
said:

"What will you do?"



"A STUDY OF FOLIAGE." BY CLISTON BROWN, AGE 16.

(HONOR MEMBER.)

And then they each began to tell what they could
do.

One said she could swim all day and she was n't
afraid of water; another said that he was n't afraid of
dogs; and still another said he could bark like a
dog.

And one said one thing and another the other, until
the genie commanded them to stop talking and do it.

But they did nothing at all. All they did was to say:

"Pussy-will-oh, pussy-will-oh!"

Then the genie got very angry and said:

"Well be pussy-willows!"

As soon as he said that they rolled themselves up
until nothing but their backs were visible, and jumped
into some bushes that were near, and remained that
way to this very day.

And whenever the wind blows they brush against
each other and you can hear them whisper:

"Puss-s-s-s-y-will-ow, puss-s-s-s-y-will-ow, puss-s-s,
puss-s-s-s!"



"A HEADING FOR AUGUST," BY S. DAVIS OTIS, AGE 15. (SILVER-BADGE WINNER)

Margaret Jaques
Harriett Dayton
Helen May Baker
Louise Converse
Earl H. Cranston
Louis P. Hastings
George C. Squires
Anna K. Cook
Mary Carr
Estella Johnson

PHOTOGRAPHS 1.

Samuel Dowse Robbins
Thomas Turnbull, 3d
Miriam H. Tanberg
Alice L. Cousens
Catherine Evans
Caroline Dудey
Kate Sprague
Lucile Morgan
Edna Lewinson
Rachel Arnold
A. Winfield Fairchild, Jr.
Alice Nielsen
Gerard Thorp
Harriette Gowen
Marion L. Bradley
Mary R. Paul
Lucy T. Dawson
Lucien Carr, 3d

PHOTOGRAPHS 2.

Dorothy V. Gresham
Olive Mudie-Cooke
Sarah Perkins Madell
Marguerite Strathy
Triscilla Ordway
Florence R. T. Smith
Margaret Griffith
Morris Luxenberg
Susan J. Appleton
G. Huntington Williams, Jr.
Ernest L. Weaver
Joel E. Fisher, Jr.
H. Ernest Bell
Charlotte Eaton
Rutherford H. Platt, Jr.
Edwina Higginson
Lewis Holbrook
Robert Solomon
Dorothy Hanvey
Alfred S. Niles, Jr.
Elinor L. P. Lyon

PUZZLES 1.

Alice D. Karr
Agnes R. Lane
Albertina L. Pitkin
Edith Younghem
Margaret Hussey
Mason Garfield
Gaylord M. Gates
Anna M. Neuburger
Bruce Simonds
William S. Maulsby
Marjorie L. Williams
Hamilton Fish Armstrong
Alice Knowles

PUZZLES 2.

Elizabeth Beale
Henry W. Ruhl
Robert W. Wood

TO NEW READERS.

The St. Nicholas League is an organization of St. NICHOLAS readers. Its aims are recreation, intellectual improvement, and the protection of the oppressed, whether human beings or dumb animals. Gold, silver, and cash prizes are awarded for meritorious achievement. The membership is free, and a badge and full instructions will be sent on application.

THE ROLL OF HONOR.

No. 1 A list of those whose work would have been used had space permitted

No. 2 A list of those whose work entitles them to encouragement.

VERSE 1

Louisa F. Spear
Margaret A. Brownlee
Emmeline Bradshaw
Alma E. Jones
Mary S. Coolidge
Caroline Millard Morton
Roscoe H. Vining
Emily Rose Burt
Clement R. Wood
Helen Leslie Follansbee
Teresa Cohen
Anna Eveleth Holman
Warren L. Irish
Robert E. Rogers
Ethel Louise Knight
Elizabeth A. Steer
Gabrielle Elliot
Susan Warren Wilbur
Dorothea Thompson
Claire Lawall
Lewis S. Combes

VERSE 2

Abby Dunning
Ethel M. Dickson
Dorothy Barclay
Muriel Bush
Maude H. Brisse
Walter MacEwen
Dorothy Nicoll
Florence Short
Elizabeth H. Crittenden
Helen D. C. Clark
Natalie Wurts
Elizabeth Toof
Eleanor L. M. Eisenbrandt
Mary Elizabeth Maur
Jessie Freeman Foster
Elsie Reed Hayes
Gladys W. Jones
Helen L. Brainard
Ruth Greenoak
Olive Louise Jenkins
Marjory Macy
Dorothy Dickinson
Lucile D. Woodling
Cuthbert Vail Wright
Nannie Cooper
Lois M. Cunningham
Corinna Long
Rebecca L. Ruhl
Virginia Peirce
Frances Morrissey
Rispah Goff

Dorothy Smith
Rachel Thayer
Mabel Lindsay
E. Adelaide Hahn
Margaret Ewing
Maria L. Llano
Charles Irish Preston
Wilbur K. Bates
Dorothy Mercer
Grace J. Conner
Emuly M. Thayer
Margaret L. Smith
Constance Gardner
Sibyl H. Wright
Lawrence Hocheimer
E. H. Gregory
Jeanette Munro
E. Babette Deutsch
Eleanor Johnson
Margaret Caskey
Josephine Freund

PROSE 1.

Dorothy Cooke
Erma Bertha Mixson
Antoinette F. Rogers
Isabel Weaver
Lael Maera Carlock
Ruth E. Wilson
Dorothy Schmidt
Edmund P. Shaw

PROSE 2.

J. P. Ackerman
Leland G. Hendricks
Marguerite Weed
Corinne Bowers
Ruth Henghes
Bertha Torchiani
Lida S. McCague
Katharine J. Bailey
Leonora Ross
Rose L. Goldbaum
Gladys A. Moch
Katharine Rutan Neumann
Gladys Caylor
Marie Armstrong
Katharine Jerlatha Synon
William F. Dever
Helen Newby
Elsie Alexander
Frances P. Gordon
Katharine E. Pratt
Frances Paine
Walter Burton Nourse

Margaret Kyle
Mary Pemberton Nourse
Stuart Marsden
Winifred Brown
Morris Gilbert Bishop
Marguerite Hunt
Louis De Forest
Elizabeth Marvin
Kathryn L. Glidden
Helen Schvencck
Henry Van Pelt
Marian C. Cooper
Charlotte St. George Nourse
Beulah Elizabeth Amidon
Marie A. Pierson
Elmer Beller

DRAWINGS 1.

Vera Demens
Jacky Hayne
Ella Elizabeth Preston
Emily W. Brown
Vieva Fisher
Robert Edmund Jones
Talbot F. Hamlin
Margery Bradshaw
Shirley Alice Willis
Laura Schnarendorf
Sarah Lippincott
Lylie May Frink
Maude H. Aldrich
Albert Hart
John R. Smith

DRAWINGS 2.

Helen Reading
Mary Ellen Willard
Elmira Keene
Roy Chapman
Grace Wardwell
Carl B. Timberlake
Raymond Rohn
Helen H. Stafford
Eleanor K. Paget
Edith Angeline Huff
Ellen Adair Orton
Sue Melanie Justice
Maude G. Barton
Estelle M. Crosby
Ruth Cutler
Anna Linker
Ethel Malitar
Martha S. Stringham
Hester Margetson
Anna A. Flichtner
Robert F. Schulkers
Lucy Oliver Beck
Mary A. Woods
Joseph Burchfield
Alice Humphrey
Margaret Duryea
Mary Falconer

Lillie Lemp
Marjory Gillian de H Brown
Aline J. Macdonald
Ethel Messervy
Carlos Cardenal
Harold Sheffield van Buren, Jr.
Katherine Dulcebella Barbour
Marguerite B. Albert
Dorothy Curtis
W. R. Wilson
Olive Garrison
Helen Mather Brown
Edith Clement
Katharine Thompson
Mildred Andrus
Bertha Scharif
Josephine Holloway
Sidney J. Cohen
Joyce M. Slocum
V. C. Merritt
Sybil Emerson
Mary Wales
Herman Gillis
Lydia Gibson
Irene Bowen
Katie Sargent
Lois Macgavock Williams
Margaret B. Wood
Ralph Holland
W. Wallace Alward
Isabel Caley
Ethel J. North
Katherine Byrer
Charlotte Cyder
Helen D. Long
Edward Estlin Cummings
Alice Cotton
Constance How
Wilson J. Brown
Katherine MacBride
Helen Townsend
Ione Casey
L. Berkeley Cox
Mary Klaunder
Benjamin Cohen

NEW CHAPTERS.

- No. 827. "Merry Five." Beulah E. Amadore, Secretary; five members. Address, Fargo, N. Dak.
- No. 828. "Conocic League Club." Corinne Bowers, President; Sybil B. Basford, Secretary; four members. Address, 102 N. Main St., Chambersburg, Pa.
- No. 829. "Sunbeam." Lenore Kester, President, Annette Howell, Secretary; seven members. Address, Box 34, Hillsboro, Ill.
- No. 830. "Fleur del Mar." Mabel Tenney, President; Grace Flanagan, Secretary; twelve members. Address, Ventura, Cal.
- No. 831. Alice Precourt, Secretary; ten members. Address, 15 Walnut St., Manchester, N. H.

LEAGUE NOTES AND LETTERS.

A good many of our contributors were late this month. They will wonder why their work receives no mention, forgetting that a magazine, like a train, has a schedule and can't wait for belated passengers.

By an error, Emmeline Bradshaw was put down as an "Honor Member" in the May issue. It is Margery Bradshaw who is the gold-badge winner; but if we may prophesy from the poem mentioned, it will not be many months before Miss Emmeline will wear equal honors.

The following named Leaguers would like to exchange souvenir postal cards: Marjorie Scarlett, 47 Johnson Ave., Newark, N. J.; Lillian Muncester, 42^{1/2} Bull St., Charleston, S. C.; Vivian Dewey, 417 Market St., Kenosha, Wis.; and Evelyn Coorse, 1370 Spruce Place, Minneapolis, Minn.

OXFORD, N. C.

DEAR ST. NICHOLAS: To-day's mail carries you two contributions from my little family, and there are others being prepared by Mary and Sophronia. I want to thank you for the pleasure you give my little ones. Their grandmother and auntie gave the ST. NICHOLAS to Mary and Sophronia last year, and Mr. Cooper and I were so pleased with the influence it had upon them that we would not, for anything scarcely, have failed to renew the subscription; but we, as well as the children, were delighted to receive the certificate that mama and my sister had sent to Sophronia, Julia, and Elliott, thinking Mary, who is 13 years old, had perhaps outgrown the ST. NICHOLAS. But they were never more mistaken; and she reads every line in it, and is also preparing a very pretty heading for April. Still, she is willing for it to come in the other children's names, as it gives them so much pleasure. The older children have been very busy lately with their school examinations; but they are over to-day, so they will again turn their attention to ST. NICHOLAS. Nina Cooper, who is only 5 years old, came to me the other day with an envelop filled with papers, which she asked me to send to ST. NICHOLAS. I took them out to examine them, and she had flowers on some sheets, birds, cats, dogs, and all sorts of things on other sheets of paper. I selected the one which I mailed to you to-day as the most appropriate for April. Sophronia's gold badge is an incentive to them all, and Mr. Cooper and I thank you so much for giving it to her. She wears it constantly, and is as proud of it as the first day she received it. Again thanking you,

Very respectfully,
MRS. H. G. COOPER.

CHICAGO, ILL.

DEAR ST. NICHOLAS: I cannot tell you how glad I was when I knew that I had really won a silver badge. I want to thank you for it, and to tell you how much it has encouraged me.

It is very pretty, but I like it still more because it reminds me of a great many disappointments and then a very pleasant surprise.

After comparing my own poems with those of other members of the League, I used to (and still do) become very disappointed with my own work. But I mean to keep on trying just the same.

Thanking you again for my beautiful badge, I am,
Your loving reader,
JESSIE FREEMAN FOSTER.

Appreciative and interesting letters have been received from L. J. Nussbanmer, Beulah E. Amidon, Richard S. Bull, Mabel Tenney,

Mary R. Ellis, George Ashley Long, Jr., Mary Grumbrecht, Richard A. Reddy, Helen E. McVior, Mason Garfield, Leonora Ross, Katherine A. Robertson, Lucien Carr, 3d, Agnes I. Peaslee, Helen D. Perry, Cecily Whitworth, Edmonia M. Adams, and Charlotte Wagh.

PRIZE COMPETITION
No. 71.

THE St. Nicholas League awards gold and silver badges each month for the best poems, stories, drawings, photographs, puzzles, and puzzle-answers. Also cash prizes of five dollars each to gold-badge winners who shall again win first place.

Competition No. 71 will close **August 20** (for foreign members **August 25**). The awards will be announced

and prize contributions published in ST. NICHOLAS for **November**.

Verse. To contain not more than twenty-four lines. Title: to contain the word "Thanksgiving."

Prose. Story, article, or play of not more than four hundred words. Subject, "A Rescue."

Photograph. Any size, interior or exterior, mounted or unmounted; no blue prints or negatives. Subject, "Camp Life."

Drawing. India ink, very black writing-ink, or wash (not color). Two subjects, "The Falls" (from life) and a Heading or Tailpiece for November.

Puzzle. Any sort, but must be accompanied by the answer in full, and must be indorsed.

Puzzle-answers. Best, neatest, and most complete set of answers to puzzles in this issue of ST. NICHOLAS. Must be indorsed.

Wild Animal or Bird Photograph. To encourage the pursuing of game with a camera instead of a gun. For the best photograph of a wild animal or bird taken *in its natural home*: *First Prize*, five dollars and League gold badge. *Second Prize*, three dollars and League gold badge. *Third Prize*, League gold badge.

RULES.

ANY reader of ST. NICHOLAS, whether a subscriber or not, is entitled to League membership, and a League badge and leaflet, which will be sent free.

Every contribution, of whatever kind, must bear the name, age, and address of the sender, and be indorsed as "original" by parent, teacher, or guardian, *who must be convinced beyond doubt that the contribution is not copied*, but wholly the work and idea of the sender. If prose, the number of words should also be added. These things must not be on a separate sheet, but *on the contribution itself*—if a manuscript, on the upper margin; if a picture, *on the margin or back*. Write or draw on *one side of the paper only*. A contributor may send but one contribution a month—not one of each kind, but one only. Address:

The St. Nicholas League,
Union Square,
New York.

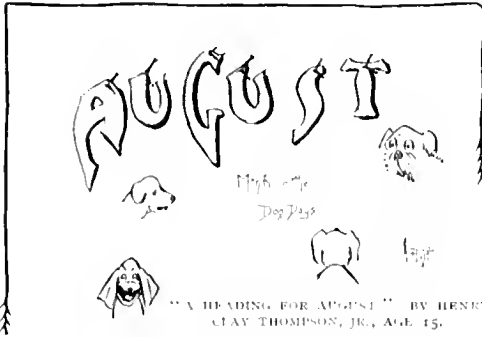

"A HEADING FOR AUGUST" BY HENRY CLAY THOMPSON, JR., AGE 15.



"GOOD-BY TO THE LEAGUE." BY JESSIE C. SHAW, AGE 17



BOOKS AND READING.

A YEAR'S READING.

FROM a young English girl we have a list of the chief books she read in one year — a list that strikes us as decidedly unusual. It includes "Sartor Resartus"; "A Girl's Ride in Iceland," by Mrs. Tweedie; Lord Roberts's "Forty-one Years in India"; "Where Three Empires Meet" and "Madagascar in War Times," by E. F. Knight; Sir Theodore Martin's translation of Horace; "Fights for the Flag," by the Rev. W. Fitchett; Ruskin's "Ethics of the Dust" and "Crown of Wild Olive"; Homer's "Odyssey" (Lang's translation); Herbert Spencer's "Education"; and several others. This is only about half of the books she read in a single year or less. We should like the opinion of our readers upon the list. It seems to us that of such substantial fare she has partaken of more than can be readily assimilated.

CHILDREN'S CORNERS.

WHENEVER you go into a large public library, a publisher's office, or a bookstore, it would be well for you to inquire whether there is not a special corner or alcove set apart for young readers. There are now so many books published exclusively for children that it is becoming usual to group them for the convenience of the readers for whom they are especially intended.

AN EXCELLENT LITTLE ESSAY.

FROM Scotland there has come to this department a charming little paper telling of some of the tributes to dogs from the poets. We take great pleasure in printing it for our readers:

IN PRAISE OF DOGS.

BY ALINE JEAN MACDONALD.

MANY great authors and poets have written about dogs. Take Wordsworth, for instance. He has a poem called "Characteristics of a Favorite Dog." This dog, Dart, while hunting a hare, tries to cross a river, only thinly coated with ice, which breaks under his weight. Little Music, his dog friend, tries to rescue him, but in

vain, although she does not relax her efforts until her companion sinks to rise no more.

Wordsworth has also a poem called "Tribute: To the Same Dog." He writes an epitaph, showing how deep is his regret over the death of his favorite.

Many people know his beautiful poem "Fidelity," telling how a shepherd finds a dog keeping guard over his master, who had fallen from a precipice and was now a lifeless skeleton.

Mrs. Browning has also something to say in praise of dogs. Every one should read her beautiful poem called "To Flush, my Dog." Her tender verses describe so eloquently the dear little dog, and show how much she loved him.

One of the most lovely poems in the language is Matthew Arnold's "Geist's Grave." I think the following verse is quite perfect:

And not the infinite resource
Of Nature, with her countless sum
Of figures: with her fulness vast
Of new creation, evermore,
Can ever quite repeat the past,
Or just thy little self restore.

All the verses are exquisite; they could not be too much praised.

Shakspeare has, as far as I can see, nothing to say in praise of dogs; for, when he does speak of them, it is always slightly. I think you will agree with me that the dog is next to man in intelligence; and, indeed, many men would do well to copy some of the noble and heroic qualities of the dog.

A NEW EDITION OF MISS ALCOTT'S WORKS.

READERS of Miss Alcott's works who are old enough to remember when the books came out, can hardly have forgotten the very crude illustrations of the first edition.

For many years the stories lacked proper illustration, but recently there has been published a beautiful new edition,— which is not yet completed,— the illustrations of which leave nothing to be desired. Lovers of Miss Alcott's stories are advised by all means to see this eminently satisfactory edition.

COLERIDGE'S COMPARISON.

So great has been the affection of readers for the books that have given them delight, that litera-

ture is full of proofs of gratitude toward noble books. There have been countless comparisons and metaphors used to make clear the relation between the book and the reader. Perhaps the most original was hit upon by Coleridge, who compares an excellent book to a well-chosen and well-tended fruit-tree. He says, "We may recur to it year after year, and it will supply the same nourishment and the same gratification, if only we ourselves return to it with the same healthful appetite."

But, though his simile pleases the fancy, it does not quite satisfy the judgment. While the fruit of a tree must yield much the same flavor always, the gratification we experience from reading must always differ according to the condition of mind of him who reads. It has been said that a traveler can bring home only what he takes with him: which means that the pleasure derived from traveling is entirely dependent upon the capacity of the traveler's mind. One's taste may change, and one's ability to understand and appreciate is constantly changing.

DID SHE DREAM IT? **WHO** can help a puzzled young correspondent from Ohio? She read some time ago a story which, according to her remembrance, was about some region in the mountains of Kentucky. A rich man, finding he owned an estate there, sent a young lawyer to make inquiry. The lawyer found a farmer occupying the estate and set about to reclaim it. The Kentuckians did their best to get rid of the young man, who was aided by the daughter of the farmer because the lawyer had been kind to a favorite dog of hers. Our young correspondent cannot recall any more of the story, nor can she remember its title. She says her family call it "the book she dreamed." Can any of our well-read friends assist her?

CHINA AND AMERICA. **TO** one who considers the history of the present day, as certainly many of our readers must do, since it is becoming very common to keep pupils informed upon current events, it is evident that when the present generation of young Americans shall grow up, they will have more or less to do with the opposite side of the world. It is not so very long ago that both China and Japan were regarded as regions of mystery. To-day, the old travel-sketches, filled with ac-

counts of oddities and strange observations, have been replaced by books of travel giving close and minute accounts of the daily life in these two old empires. Kirk Munroe, a favorite author with boys fond of wholesome and stirring stories, not long ago resolved to lay the scene of a boys' story in China, and made a journey to that land that he might truthfully picture the surroundings of the events described. The story, "The Blue Dragon," deals with the experiences of a Chinese boy in America, and then with those of an American boy in China, thus contrasting the two lands and their treatment of strangers. Besides being an adventurous and thrilling story, this book will acquaint young Americans thoroughly with the conditions of life among the Celestials.

A YOUNG MUSICIAN. **WE** have often invited readers of this department to apply for information in regard to their reading, and now we have a young musician who begs for a list of some good books about the lives of great musicians, and also books that tell the stories of the greater operas. She is fourteen years old, but says that she prefers books that will be interesting to her all her life if she goes on studying music. Will not some other lovers of music come to her aid?

THREE NEW BOOKS. **THOSE** who are seeking for novelties in fairyland should by no means omit to read a "Japanese Fairy Book," by Yei Theodora Ozaki. Everything about the volume is Japanese, even the illustrations; so one may be sure of getting an entirely new atmosphere. To accompany this in a companionship of strangeness, we may name Dr. Eastman's "Red Hunters and the Animal People." Our readers will remember that Dr. Eastman is an educated Sioux Indian who wrote for *St. Nicholas* his remembrances of his childhood. This new book is made up of animal stories and accounts of the Indian hunters, and should be well worth reading.

Young readers who may be interested in the marvels of modern science will find great delight in Russell Doubleday's "Stories of Inventors," a pleasing discussion of wireless telegraphy, the recent improvements in telephoning, the wonderful biograph, and other up-to-date triumphs of mechanical ingenuity.

EDITORIAL NOTE.

By an oversight, three drawings showing a toy water-wheel in operation (printed on page 716 of our June number) were credited to Mr. Joseph Adams. They were really the work of the well-known artist Mr. Dan Beard.

We take pleasure in stating, too, that Mr. Beard is the originator of the tree-huts or tree-houses now so popular with boys. Mr. Adams's article upon this sub-

ject, in the July number, showed the models of a few easily constructed habitations of this sort, and we have received from our boy readers several photographs of tree-houses made by themselves. One such picture, indeed, is published in the July Letter-Box.

To Mr. Beard, however, belongs the credit of being the first to devise and publish the plans for practicable tree-huts for boys' use during the summer.

THE LETTER-BOX.

UNDERHILL, VT.

DEAR ST. NICHOLAS: I am a little girl eleven years old. I do not subscribe for you, but my mama buys you for me every month.

I like you very much.

I have a parrot named "Plato" and a little fox-terrier named "Beauty." I also have a piano and am taking lessons on it.

I like all the stories in ST. NICHOLAS very much. My mama took you for a good many years.

With all good wishes for your future, I am,

Sincerely yours,

ALMA HOPE SCRIBNER.

GERMANTOWN, PA.

MY DEAR ST. NICHOLAS: I am a little boy nine years old. I live in the State of Washington, near Tacoma. Now I am in Germantown, Pa., at the Institution for the Deaf. I am learning to talk, write, and read. I like ST. NICHOLAS. I try to find out the enigmas. I have found out several. My aunty helps me. I like them. I did not see any rabbits in Washington. I have seen many here. My papa has seen many bears in Washington. I have seen many deer. I have one pony. Her name is "Polly." Some day I will go back to Washington and ride my pony.

Yours very truly,

JAMES MORRIS LOWELL.

SPRINGFIELD, N. H.

DEAR ST. NICHOLAS: I live in the country, a small town in New Hampshire. I go snow-shoeing and skeeving, also sliding; we have lots of snow.

A friend sent ST. NICHOLAS to me for a year, and I cannot tell you how very much I am enjoying it.

I am getting a collection of souvenir postal cards. We have several pretty views of places in town.

Your friend,

BESSIE I. GARDNER (age 13).

PAPEETE, TAHITI.

DEAR ST. NICHOLAS: My brother and I have taken you for a long time, and we like you very much. The steamer only comes here every five weeks, and I watch for the ST. NICHOLAS.

I live in Tahiti, in the South Seas, on a big sugar-plantation. There are lots of cocoanut, banana, bread-fruit, maumie-apple or papaw, burau, guava, feis, pandanus, bamboo, and mango trees on our place.

The natives are big and strong. The men wear a pareu, or colored cloth, around their waist. They live on feis, bananas, miti or cocoanut-sauce, and fish.

In the middle of the island, between two high mountains, there is a smaller mountain, shaped just like a crown, which is called "the Diadem."

My brother brought his Indian pony from San Francisco, and she did not get seasick at all; but papa's riding-horse died on the way down.

We have plenty of rain in December and January—it is our summer then.

Your devoted reader,

RONALD S. ROBINSON (age 9).

DEER PARK, WIS.

DEAR ST. NICHOLAS: My sister got you as a Christmas present in 1903. She enjoys you very much, and so do I.

I am nine years old, and am in the fourth grade. I hope I will be in the fifth grade next year. My sister is in the eighth grade.

She is fourteen years old. My father is a minister.

We have two cats and a horse. I used to have a dog, but he was shot. The cats are both Maltese. One cat weighs twelve pounds, and the other five. They are very good friends. The larger cat will give up anything and let the other cat have it.

Yours truly,

GERTRUDE JACOBSEN (age 9).

DEAR ST. NICHOLAS: I like ST. NICHOLAS very much. I used to take "Little Folks." It is a nice book, but not as nice as you. I used to take "Four-footed Friends," too, a book published by the Animal Rescue League. I like the story of "Queen Zixi of Ix." You were very kind to send us November and December, so we could begin the story.

From your reader,

ROBERTS BANCROFT.

DEAR ST. NICHOLAS: I have not written to you before, so I thought I would write this month. I was perfectly delighted to find that my puzzle had got in, as it was the first thing I sent to the League, and I did not expect to have it in so soon.

I have taken the ST. NICHOLAS as long as I can remember, and have always looked forward with great pleasure to the first of each month.

New Year's number was most interesting. I always start at the first page, and it seems that each page you read is more interesting, and I always read from cover to cover.

I am your affectionate reader,

JUANITA READ HARMAR (age 11).



ANSWERS TO PUZZLES IN THE JULY NUMBER.

CHARADE Inn-dee-pen-dents, independence

CENTRAL SYNCOPATIONS. Longfellow. 1. Sol-lar. 2. Flo-at. 3. Ag-n-es. 4. Fa-g-ib. 5. Lo-f-ts. 6. Sp-e-er. 7. Tel-ed. 8. Wi-ly. 9. Sh-o-ut. 10. Ho-w-er.

MULTIPLE CROSS-WORD ENIGMA. Hans C. Andersen, St. Nicholas, Queen Ziti of IX

PATRIOTIC NUMERICAL ENIGMA "A star for every state and a state for every star"

NOVEL DIAGONAL. From 1 to 15, Independence Day. Cross-words: 1. Identify. 2. National. 3. Defender. 4. Eminent. 5. Prelude. 6. Ennobled. 7. Negation. 8. Disperse.

CONCEALED CENTRAL ACROSTIC. Vacation. 1. Riv-er. 2.

TO OUR PUZZLERS: Answers, to be acknowledged in the magazine, must be received not later than the 15th of each month, and should be addressed to St. Nicholas Riddle-box, care of THE CENTURY CO., 33 East Seventeenth St., New York City.

ANSWERS TO ALL THE PUZZLES IN THE MAY NUMBER were received, before May 15th, from Daniel Milton Miller—Ruth H. Caldwell—Alice Patterson—Caroline Ray Servin—St. Gabriel's Chapter—"Kategiam"—Laetitia Viele—"Duluth"—Samuel Simes Richards, Jr.—Eva Garner—Frieda Rabinowitz—Laura Florence Lacy—Eugenie A. Stenier—Katharine King—"Chuck"—Elizabeth Palmer Loper—Helen G. Johnson—W. Carter Herbert—Edmund Willis Whited—Grace Haren—Frederick B. Dart—John B. Hollister—"Allid and Adi"—Ellen J. and Rosa May Sands—Harriet Bingaman—Helen L. Patch—Elizabeth Delo—Mildred D. Yenawine—Jo and I—Mary E. Seeds—Paul R. Deschere—Mary Elizabeth Askew—C. Anthony—Mina Louise Winslow—Helen Hamilton Stroud—Benjamin L. Miller—Margaret Greenshields—Florence DuBois—Buford Brice—"The Spencers"—Leah E. Stock—Helen Hoag—Elsie Nathan—Eleanor Wyman—Mary McCune—Dorothy B. Usher—Florence G. Mackey—Marian Swift—Helen Jelliffe—Marjorie Mullins—Wm. H. Bartlett—Eleanor Underwood—Nessie and Freddie—Julian A. Fleming—Esther, Clare, and Jean—Elizabeth D. Lord—Florence R. Elwell—Catharine Hooper—Clements Wheat—Lilian S. Burt—Prue K. Jamieson—Louis Sux Weiss—Margaret H. Kellogg—Ruth H. Darden—Jeannie R. Sampson—Andrée Maute—Marguerite Jervis

ANSWERS TO PUZZLES IN THE MAY NUMBER were received, before May 15th, from D. Gilpin, 1—C. Hackstaff, 1—R. Bennett, 1—K. E. and G. L. Wheeler, 1—R. Read, 1—A. S. Ward, 1—A. Macalester, 2—W. Ripley Nelson, 1—K. Comstock, 1—G. H. Moore, 1—R. Alexander, 1—J. C. Haddock, Jr., 1—H. R. Crouch, 1—M. Weyand, 1—Penelope B. Noyes, 4—G. H. Morse, 1—James F. Martin, 3—K. L. Munroe, 1—E. Crampton, 1—Dorcas Perkins, 1—R. W. Moore, 1—C. E. Montgomery, 1—A. H. Chapin, 1—Jack and Hill, 6—Marjorie Skelding, 1—Thomas W. Trembath, 3—L. S. Clapp, 1—H. L. K. Porter, 1—A. Wight, 1—E. M. Warden, 1—S. H. J., 6—B. Carleton, 2—P. Briggs, 1—Bryant Hervey, 2—Muriel von Tunnelmann, 6—Agnes N. Holmes, 1—Edward Fox, 1—J. E. Swain, 1—Grace Parmele, 2—R. B. Pritchard, 5—May W. Ball, 6—Leila H. Dunkin, 6—M. and T. M. Douglas, 3—H. Kraay, 1—B. Smith, 1—C. McNitt, 1

CHARADE.

COME, my *second*, in my *first* :
Here my *puzzle* is rehearsed,
Though my *whole* is small indeed,
It must serve my every need.

ANNA M. PRATT.

DOUBLE BEHEADINGS AND CURTAILINGS.

(Gold Badge, St. Nicholas League Competition.)

1. DOUBLY behead and doubly curtail certain wind-instruments, rearrange the four remaining letters, and make the little stint of India.
2. Doubly behead and curtail expressing derision, rearrange, and make the goddess of the rainbow.
3. Doubly behead and curtail to grow together, rearrange, and make to fasten with wax.
4. Doubly behead and curtail supple, rearrange, and make a wild Alpine goat.
5. Doubly behead and curtail one of the cases of the noun in Latin, rearrange, and make part of a squirrel.

En-a-et. 3. Fa-et. 4. De-aw. 5. Ac-tor. 6. St-ell. 7. Th-orn. 8. Sa-n-ds

ADDITIONS. James Wolfe. 1. Room, Jordan. 2. Dana, Adrian. 3. Aden, Medina. 4. Osen, exocen. 5. Pier, spider. 6. Teal, wallet. 7. Cord, orchid. 8. Nile, linnet. 9. Reef, tarret. 10. Wage, earwig.

TRIPLE BEHEADINGS. Caesar. 1. Dis-charge. 2. Cap-sable. 3. App-eased. 4. Bed-spread. 5. Car-away. 6. Sea-red.

DOUBLE ZIGZAG. From 1 to 2 and 3 to 4, The Declaration of Independence. Cross-words: 1. Fomado. 2. Sheriff. 3. Sterile. 4. Editing. 5. Imagined. 6. October. 7. Eclipse. 8. Bayonet. 9. Refrain. 10. Cascade. 11. Between. 12. Piquant. 13. Organic. 14. Induced.

6. Doubly behead and curtail the French word for pavement, and leave a German masculine name.

7. Doubly behead and curtail winds and turns, rearrange, and make a feminine name.

8. Doubly behead and curtail messengers, rearrange, and make a narrow opening.

9. Doubly behead and curtail magnificent, rearrange, and make one who goes.

10. Doubly behead and curtail a brief, rearrange, and make crafts.

When the ten words of four letters each have been rightly guessed and written one below another, the zig-zag, beginning at the upper left-hand letter, and ending with the lower right-hand letter, will spell the name of a great Greek sculptor.

RUSSELL S. REYNOLDS.

WORD-SQUARE.

1. To slope. 2. Farther down. 3. Conscious. 4. Courage. 5. Large vegetable growths.

DAVID W. COLFITTS, JR. (League Member).

NUMERICAL ENIGMA.

(Silver Badge, St. Nicholas League Competition.)

I AM composed of forty-nine letters and form two lines from a well-known poem.

My 35-2-23 is a busy insect, and my 19-8-40-48-27-5 is a little web-spinner; my 30-46-8-33-10 is a familiar tree, and so is my 16-42-30-44-28-14-1-24. My 17-37-8-6-20-32-16-11 is a spring flower, and my 3-11-13-49-43 is a summer flower. My 41-29-9-22-7-42 is a bird with a sweet song, my 25-46-31-4-21 is a bird of sable plumage, and my 45-35-47-6-36-18-9 is a bird of brilliant plumage. My 28-26-46-34 is a fresh-water duck, while my 12-40-15-38 is delves.

VIRGINIA LIVINGSTON HUN1.



IN this numerical enigma the words are pictured instead of described. When the eleven objects have been rightly guessed, and the thirty-six letters set down in proper order, they will form the first line of a famous verse.

Designed by MILDRED WINTHROP WESTON (League Member).

TRIPLE BEHEADINGS.

(Gold Badge, St. Nicholas League Competition.)

1. TRIPLY behead glaring, and leave to allow.
2. Triply behead back dues or rents, and leave part of the head.
3. Triply behead the workroom of a chemist, and leave the art of speaking well.
4. Triply behead to contract, and leave a line.
5. Triply behead a bugaboo, and leave a malicious elf.
6. Triply behead to resolve, and leave a kind of fur.
7. Triply behead external, and leave a division of a hospital.
8. Triply behead the face, and leave cra.
9. Triply behead the edge of a road, and leave lateral.

10. Triply behead a relative, and leave to cut down.
11. Triply behead ascending, and leave sick.
12. Triply behead lion-like, and leave a number.
13. Triply behead an agreement, and leave profit.
14. Triply behead the god of the ocean, and leave an air.

15. Triply behead to disclaim, and leave to possess.
 16. Triply behead a red stone, and leave a snare.
 When the words have been rightly beheaded, the remaining words will spell the name of a famous personage.

HELEN SEMPLE.

A DIAGONAL PUZZLE.

(Silver Badge, St. Nicholas League Competition.)



Cross-words: 1. To give up. 2. Slanting. 3. A short, light musket or rifle. 4. A breastwork. 5. Tracts of swampy land. 6. One of the three kingdoms in which things are generally classified. 7. The smallest amount. 8. To have the upper hand. 9. Pertaining to animals that live at the surface of the ocean. 10. Deep gorges. 11. To steal off. 12. Lack of rain. 13. A mathematical term. 14. A quack medicine.

From 1 to 2 and from 3 to 4 spell the name of a very famous person.

CORINNE J. REINHEIMER.

CONNECTED WORD-SQUARES.



- I. UPPER LEFT-HAND SQUARE: 1. Binds. 2. An island. 3. A feminine name. 4. An aquatic animal.
- II. UPPER RIGHT-HAND SQUARE: 1. The amount paid. 2. A masculine name. 3. To move. 4. A member of the conservative party.
- III. CENTRAL SQUARE: 1. Final. 2. A part sung by a female voice. 3. A luminous body. 4. Severed.
- IV. LOWER LEFT-HAND SQUARE: 1. An inventory. 2. Within. 3. To remain. 4. Playthings.
- V. LOWER RIGHT-HAND SQUARE: 1. Weapons. 2. Genuine. 3. The hair on the neck of a horse. 4. A winter vehicle.

WILMOT S. CLOSE (Honor Member).

OMITTED LETTERS.

REPLACE the * by the same letter in every word.

- 1 * * * * * A mountain of Asia.
- 2 * * * * * A city of the Antilles.
- 3 * * * * * The pineapple.
- 4 * * * * * A desert.
- 5 * * * * * A kind of labor, used by the Moors.
- 6 * * * * * A famous isthmus.

ERWIN JANOWITZ (Honor Member).



"WE HAVE LOST A BEAUTIFUL CLOAK IN THE LILAC GROVE,"
SAID QUEEN ZINI TO THE SHEPHERD."

ST. NICHOLAS.

VOL. XXXII.

SEPTEMBER, 1905.

NO. 11.



A CHANGE OF CRAFT.

BY

Richard W. Child.



FROM a boy's standpoint, Seattle is one of the most interesting ports on the Pacific coast. Robert Cole, whose father had lost all his fortune after the boom had ended and the false prosperity of a newly built city was over, lived very near the waterfront, and used to spend many hours, when he was not in school, in dangling his feet over the edge of a dock, and watching the interesting shipping in the busy Puget Sound port.

Bobby had a little craft himself. It was an old row-boat with a leg-o'-mutton sail, but it did very well for a day's cruise around the wooded islands of Puget Sound in the summer season, when the days were mild and pleasant, and the sunlight was dazzling white on the snow-cap of Mount Rainier. Charley Ruggles, who was the son of one of the harbor pilots, and who had taught Bobby all he knew about sailing and the winds and tides and currents, nearly always went with him on the daylight sails of exploration about the Sound.

One day in August the boys had arranged to sail over to the western shore of the Sound to a fishing settlement of Siwash Indians. Bobby

had come down to the float where the *Ready*, as he called his sail-boat, was tied up; it was early morning, with a heavy mist over the bay. Bobby peered over the wharf-edge and saw Charley bailing out the boat. Beyond, there was the queerest-looking craft he had ever seen, fretting against the piles on the other side of the dock; in the mist and against the dark surface of the water he could hardly see her, although she was only a few yards away. From the tip of her stem to the edge of her rudder, all along her thirty feet of thin, narrow length, she was painted a dull, neutral gray, the color of battleships in war-time. At her bow was a little black machine-gun peeping out from a cover of gray canvas, she looked for all the world as if she were built for the use of pirates.

"Hello! Charley," cried Bob, swinging himself down the slippery ladder to the float. "What boat is that?"

"Don't you know?" answered the other, looking up, red in the face from stooping over; "that 's the *Smuggler's Nightmare*, or at least that is what they call her."

"The smuggler's what?" exclaimed Bobby.

Copyright, 1905, by THE CENTURY CO. All rights reserved.

"Why, you know how much smuggling of Chinamen and opium there is in the Sound. Well, that 's the boat the government has built to catch the smugglers. She 's gray and can't be seen any distance, and she has electric power and so is very fast and does n't make any noise. Besides, she does n't draw much water, and can travel all along the shore of the shallow inlets."

"She looks like a ferret," commented Bobby. There was something silent, dark, and mysterious about the curious craft; and even when the boys had sailed out into the running tide with the brisk morning wind which was blowing the fog over the steep shores, Bob turned back for a last look.

"We have had the wind at our back all the morning," said Bobby, about noon; "and unless it shifts we will have to beat our way every inch homeward."

"It 's just possible we won't get there at all!" Charley wet his finger in his mouth and held it up to get the direction of the wind. "I can't make out where this new breeze is coming from."

The sail had first been filling and then flopping loosely with the rattle and squeak of the rigging.

Suddenly the breeze dropped altogether, as if it had been shut off by a curtain.

Charley scowled. He looked anxiously at the gray clouds that had slanted up across the western horizon, and toward the north, where a white film of fog was rolling toward them across the water.

"We 're going to be becalmed," he said finally. "I thought so."

"What mean luck!" said Bobby, dipping his fingers in the water. "We've only got one oar, and we may not get any wind before to-morrow morning. I'm mighty glad, though, that my mother will understand that we are becalmed," he added in an endeavor to find something cheerful about the situation.

Charles nodded. "What time is full tide?" he asked.

"I don't know," said Robert. "It must be nearly full now. Are you wondering—"

"Yes," interrupted Charles. "I'm wondering how far the tide will take us before morn-

ing." He picked up a splinter of wood from the bottom and opened his jack-knife. "I wish we had a salmon-line," he said.

The gray fog, damp and salty, had rolled up the bay and, growing heavier and thicker, shut off the sight of the opposite shore. Behind the curtain of fog the radiant glow of the sun grew redder and then faded slowly away.

"Is n't it funny that we are not scared?" asked Robert, who was killing time by making knots in a piece of rope. "If this fog should n't lift—say for three days—we might starve here."

Charles did not answer. He was looking over the boat's edge into the oily water that licked the white-painted sides.

"We would n't starve in this exact spot," said he, gravely looking up. "Feel of that rudder!"

"Why, we are under way!" exclaimed Bob, as he felt the slight resistance of the helm. "And look at that seaweed go by!" He cast a glance at the sail; it was still lying limp against the mast.

"It 's the tide!" said Charles. "It 's running out!"

"The tide!" echoed the other. "I've never seen a tide rush along like this."

"But we are on the other shore, and among these islands just off the point here it empties like an upset pail," explained Charles, who knew the waters of the upper Sound well. "We can travel fifty miles on this current before daylight, and it 's nearly dark now!" He looked searchingly out into the fog, which with the coming of night had lost its filmy-white color. "I wish I knew in which direction the point lies,—we might steer our course toward it and row into shallow water. I know the direction of the current, but I can't tell just which way we are going."

"Why, I can find out," Bob said, "by feeling of the rudder. There, look how straight it is! We 're pointing right down the current now."

"Good!" said Charles. "Now I will row on the port side, and that will keep us edging over toward shore."

"It 's cold enough," mused Bob; "and I wish I could have a hot slice of roast beef."

"Don't joke," said Charles, who understood

the dangers of being carried into the maze of island waterways of the Sound. Both boys sat dejected and helpless, preparing themselves for a long fast and a cold night on the water.

Suddenly Bob started. "Did you hear that?" he cried. The muffled sound of the explosive pounding of a naphtha-launch came to them over the waters.

"Yes," said Charles, straining his ears. "Listen! Is it coming nearer? I think we'd better yell to them." He threw his head back and shouted, "Ahoy, there!" several times. The noise of the naphtha-engine stopped for a moment. Charles continued his hallooing, and then a curious thing happened: behind the curtain of fog and darkness the chugging noise of the launch began again; but this time, instead of coming nearer, it faded rapidly away. The boys looked at each other in amazement.

"Well, whoever they are—they 're mean enough," said Bob, indignantly.

Charles nodded. "I should say so," said he. "Now we have the problem of spending the whole night in this wet mist; and, what is more, no one can tell where we will be in the morning." He dipped his hand in the water again, and it rippled up on to his wrist. "We are still moving fast enough," he announced.

"What time is it?" asked Bob, after a long and patient silence. Charles struck a match and found it was already nine o'clock. The fog had begun to take on a new white radiance, and just the faintest breeze moved the baggy sail.

Suddenly the boat bumped over a rock and, with a slight shiver, turned half around. "Shal-

low water!" cried Robert. "And see—the moon shows! The fog must be lifting."

"You 're right!" said Charles; "and look there!" Both the boys could make out black shadows against the moonlight. They were skirting along the shore of one of the islands. Charles picked up the oar and in a few rapid

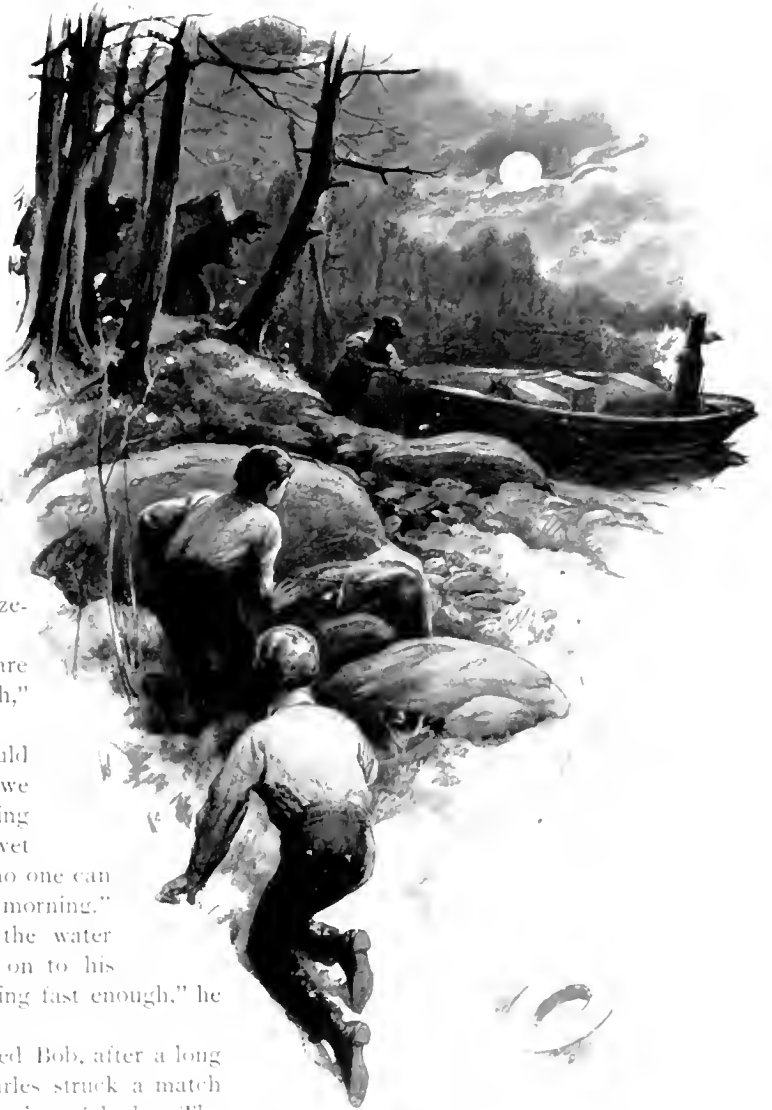

"LET DOWN BEHIND THESE ROCKS," WHISPERED CHARLES."

strokes had sent the little craft inshore. The boys jumped out and stretched their legs.

"This island, anyway," said Bob. He stopped suddenly, for not fifty yards away through

the pines he saw the light of a lantern moving toward the beach. It was carried by a short, stocky man, who was followed by two others carrying several small wooden boxes. One of



"THEY TUGGED AWAY TO GET HER INTO DEEP WATER."

them said in a voice that the boys could hear plainly enough: "Blow it out. What is the use of taking any risks?"

Bob thought only of getting home; he had already filled his lungs to shout, when he felt Charles's hand tighten upon his wrist and heard him whisper: "Keep still, Bob! Can't you see—they're the smugglers! There's the launch we heard. See it on the shore?"

It was as Charles said; a black launch loaded with small wooden boxes had been pulled over the gravel into shallow water. As Bob looked the lantern was blown out and the beach was once more in darkness; the light of the moon had grown stronger, and a

faint night breeze was sighing through the pines; the fog was lifting.

"Get down behind these rocks," whispered Charles. "You can't tell what they would do if they should find us here. It's lucky that the *Ready* is around the point, for her sail would surely show in this moonlight."

The rumbling voices of the men continued.

"There! These are all stowed away. Another trip and we'll have a full load," said one.

"Light the lantern," said another, in a complaining voice. "I keep tripping over these rocks."

"Look!" whispered Charles in Robert's ear. "You can see their shadows through the trees. Now is the time for us to get away."

Robert set his mouth in a determined manner. "See here, Charles," he said; "these men are law-breakers. They're cheating the government. It would be cowardly to run."

"Well, what are you going to do?" inquired Charles, cautiously rising to his feet.

"You can run a naphtha-launch."

"Yes."

"Then we have n't a second to lose. The men will be back in a minute. I'm going to take that launch and her cargo back to the revenue officers, and leave these smugglers prisoners on this island."

"Whew!" exclaimed Charles, in an astonished tone. "Think of the danger! And, besides, the men could escape in the *Ready*."

"No," said Bob, firmly. "I'll push the *Ready* out into the current. We ought to take the risk."

Charles was enthused by the idea. "I'll do it!" said he. He ran back and pushed the little sail-boat out into deep water; when he had waded beyond his waist he gave her a final push that sent her out into the channel.

As he came back to the beach he heard once more the voices of the men approaching. "It's too late!" he whispered. "They're coming!"

"It's our only chance to get off this island—now the *Ready* has gone," said Bob, his voice trembling with excitement. "Come on!"

The two boys started down the beach in a race for the launch. As they tugged away to get her into deep water, the lantern was coming

ner and nearer through the trees, and finally to I heard the angry cry of the bearer of the light and the swift beat of feet on the crunching gravel.

"Quick!" cried Bob. "Jump in!" Both

only got to the water's edge when the propeller of the launch began to buzz, and Tom boiled up in the broadening wake.

"Come back here!" shouted one of the men, frantically running into the water.

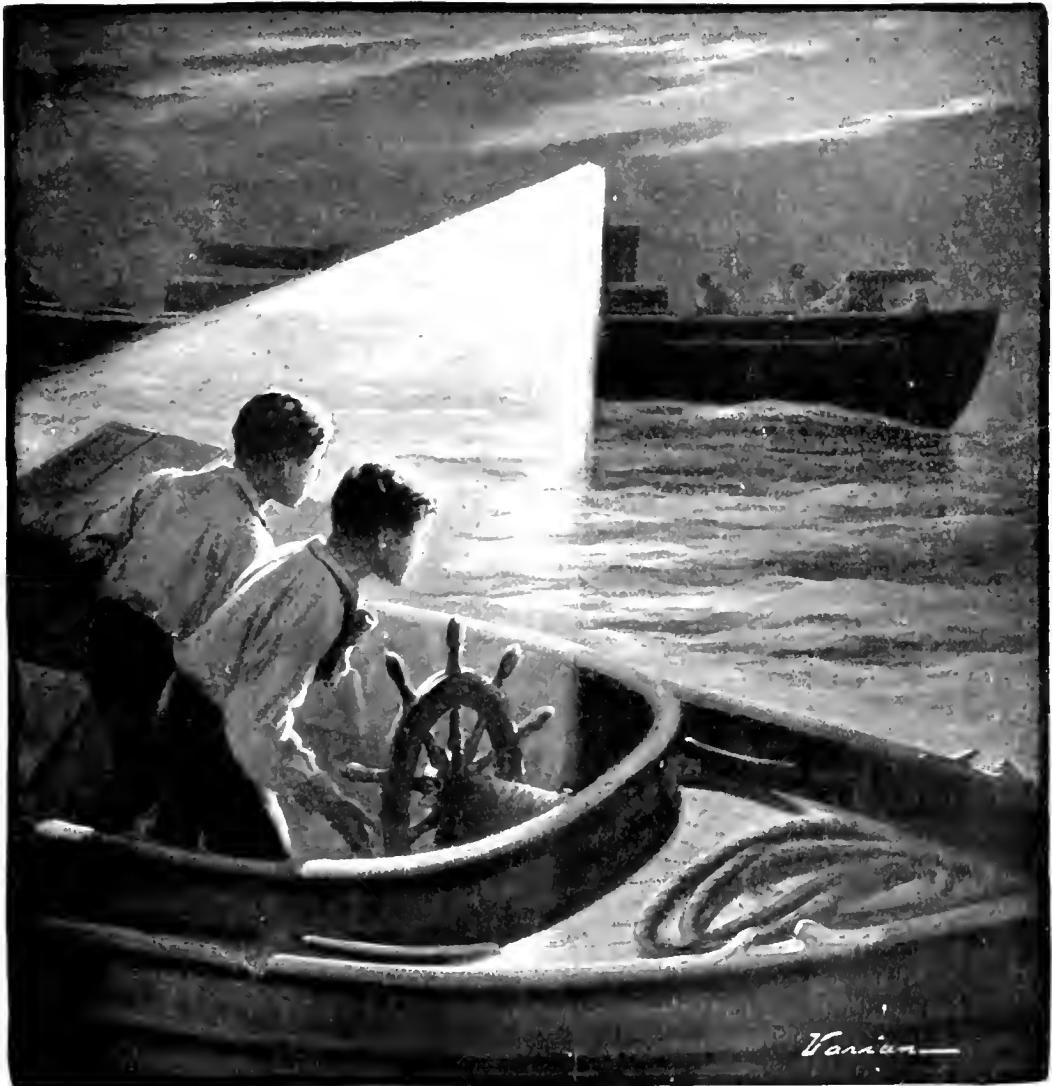

boys sprang over the side of the launch, which now floated in the deeper water. The moon had been obscured by a cloud, and Charles had to feel for the wheel and lever to start the little engine. The three men were running down the beach, shouting hoarsely, and had

"Stop or I'll shoot!" cried the other. Through the darkness the boys could see that one of the smugglers had drawn a revolver.

"Get down behind the boxes," shouted Charles to Bob. "They'll follow us along the beach and take a shot at us."

The men were running along the shore, following the direction in which the launch was going at an ever-increasing speed; at last one of them stopped and took deliberate aim.

"Don't shoot!" cried the stocky man, knocking the other's hand into the air. "We're caught here like rats and we don't want to be taken for murder."

Bob, in the bow with his hand on the wheel, gave a sigh of relief as the craft drew swiftly away from the island. "Where shall I steer?" he asked.

"I'll take her," said Charles, crawling over the boxes. "We'll steer for those lights."

The launch pounded along over the black waters, and finally turned into the open Sound; but the boys were too excited to say much. Suddenly Charles stopped the engine. "Listen!" said he.

Behind them they could hear the pounding of a propeller in another boat. "They're chasing us!" cried Bob. "Start the engine again."

Once more they were off. "We've got to race for it now," cried Charles; "they're after us, sure enough. You see, they carry no lights."

The launch now plowed along at her top-most speed, but it soon became evident that the other was gaining.

"There's only one chance," said Charles, excitedly,— "if we stop the engine they may go by us in the dark." Already his hand was on the lever, and immediately the noise ceased, and the craft slid along silently through the black water. Voices on the other boat began to sound distinct.

"They've stopped their engine," said one. "We'd better take a look!"

With a quick flash the beam of a search-light stretched out over the water like a long finger. It turned this way and that, and then suddenly settled on the launch with its two boys and its cargo of boxes.

"Oh, we've got 'em this time!" shouted a voice, and the blinding light began to come nearer.

"It's all over with us," said Charles, dismally. Bob was about to answer when the other craft slid alongside. She was thin and

dark, and there was the muzzle of a machine-gun poking over her bow.

"It's the *Smuggler's Nightmare!*" cried Bob.

"Why, they're nothing but boys!" exclaimed a bearded man in a trig blue uniform, more astonished than any one.

"Give us a hand, please," said Bob, "and I'll come aboard and explain."

To the revenue officer the boys told the whole story. He listened intently to all that they said. Every now and then he nodded and remarked: "Good work! good!" But when they explained how they had left the smugglers prisoners on the island, he chuckled heartily and slapped his knees. "This is splendid!" said he, finally. "I'll put a man into the launch with you so that you can go right home. You must be very hungry and tired. Of course we will have to go to the island for the men."

"If you should happen to see our boat, I wish you'd pick it up—we shall miss her badly, sir," said Bob.

"Oh, I would n't worry about your boat, young man!" said the officer. "There is enough reward for the capture of these smugglers to buy you a very respectable little cruising-yacht—cabin and all. And it seems to be very plain that these rascals are not only caught, but held prisoners by your act. Now we must hurry a little."

Both the boys and one of the sailors got into the launch. "Good night!" shouted the revenue officer. "Good night!" the boys answered joyfully.

Once more the naphtha-launch started on her journey toward the harbor, but this time instead of sneaking along she bore a light at her bow and carried two very tired and very happy passengers.

"It is n't so bad being becalmed, after all," said Charles, when they had climbed up on to the wharf and were saying good night.

"No, indeed!" Robert said heartily; "and we won't really lose the *Rauzy*, either, for I took the bearings of a little cove she drifted into as we were coming out with the launch."

SOME SIMPLE SUMS.

BY CHARLES LOVELL BENJAMIN.



PLEASE figure out, as school-day comes,
The sense and nonsense of these sums :

TACKS ON TEA.

WHILE bringing in 2 cups of tea
If Mary Ann should step upon
A carpet-tack, I think that she
Would put down 2 and carry 1.
If picture shown portrays her actions
Correctly — give result in fractions.

APPLES AND ACHES.

FOUR little boys consume 16
Large apples (*not* large and *green*):
This proves to any, but a dunce,
That 16 into 4 goes once.

If every apple caused a pain,
How many little boys remain?
The answer 's 8. Before the trouble
The boys were 4 — and now they "double."

A COW ACCOUNT.

A cow that gives 9 quarts a day
When milk is worth 8 cents a quart,
Eats 96 cents' worth of hay
Each day. Now work out this report.
Would not a self-respecting beast
Eat less or give 12 quarts at least?



THE MAIDS AND THE MOTTO.

BY MARGARET JOHNSON.

I

THE president had put on a little pink sun-bonnet, tying it naively under her round chin.

The secretary observed this piece of frivolity with an eye of gloom. "Alice," she said, "that bonnet is — unparliamentary!"

"But if the girls will have the meeting in the garden!" urged the president, softly. "And, besides, it 's rather — becoming, don't you think? You would n't want me to look ugly, Dody?"

This was really too ridiculous. The secretary's grim features relaxed.

"You will have your own way, whatever happens," she said; "so I don't suppose it matters much what you wear. Only don't expect *me* to fall in with your Kinder-Sinfonie scheme, bonnet or no bonnet! I have more serious things on hand I can assure you."

This was in the privacy of the president's own room, before the meeting. Shortly after, she and the secretary went out into the garden, where the rest of The Merry Maids were already assembled.

The month was only March, but on the sunny side of the high brick wall which separated the grounds of Miss Burnham's school from those of her neighbors, the vines were already in full leaf, and a glint of purple showed among the budding lilacs by the gate. These, and a warm, warm sun, and the devastations of broom and dust-pan in their own apartments, had sent the club out with one accord to its favorite haunt.

It was seldom, indeed, that this honorable body held two consecutive meetings in the same place. It led at the best a somewhat harassed existence, owing to the whims of teachers, the demands of study-hours, and the like. Hence the more need for the president's eloquence, which on the present occasion won the day for her cause.

She referred with pathos, aided by an effective droop of the bonnet, to the waning fortunes

of the club, its lack of enterprise, its waste of talent. She alluded feelingly to the state of its exchequer. And then, warming to her subject, she unfolded her plan of relief — money, glory, and no end of a good time, to be obtained simply by the exercise of a little energy and of their combined and unquestioned ability.

When she dropped, breathless, upon the arbor-step, the success of the Kinder-Sinfonie project was already assured. The motion was made and carried in the twinkling of an eye. Unbounded enthusiasm followed. A date was agreed upon, committees were appointed, and



"'ALICE,' SHE SAID, 'THAT BONNET IS — UNPARLIAMENTARY.'"

the club adjourned, going gleefully to put its rooms in order and to study its lessons.

Then it was that the president, still flushed with victory, put her books aside after a desultory glance, and sought the secretary's room.

That officer was sewing by the window, and beside her sat one of the little girls, a slender child, whose long locks of fair, straight hair fell over the book in her lap and the industrious small finger tracing out the words.

"Go on, Maugy!" said the secretary. The child's name was Maudie Dugall, corrupted by the girls into the endearing and felicitous title of Maugydoodle.

"Dan — loks — out — of — the — winder," read Maugydoodle, laboriously.

"Wind-*ow*," corrected the secretary. She was always kind to the little girls, who adored her in consequence. "Don't you remember I told you wind*ow*, pill*ow*? —"

"Yes," said the child, gravely. "I can say 'em all now, Miss Dora, — wind*ow*, pill*ow*, banan*ow* —"

"There!" said the president, pettishly. "You see how much good it does to teach her!"

She dropped down on the cushion at that moment somewhat haughtily vacated by Miss Dugall, and leaned her head against the secretary's knee with a gentle sigh.

"You 'd like to lead the symphony, Dody?"

"No," said the secretary, sewing a button on the wrong side of her glove with great energy: "I would n't."

"But you will do it to please me, Dody?"

"No," repeated the secretary: "I don't think I shall."

"I have to play the piano, you know, and there is no one else who knows how to conduct!"

No answer.

"*Dear!*" murmured the president.

"That," said the secretary, with severity, "is also unparliamentary and is not fair!"

"*Darling!*" amended the president, softly.

The secretary ripped the button off the wrong side of her glove and began to sew it on the right. The president's face was fortunately hidden from her by the unparliamentary bonnet, which she still wore, though it was no longer necessary.

"Alice," said Dora, "the trial-debates are to come off at just about the time that you have chosen for the symphony. You are not interested in them, I know, but then I am. Do you understand? — but of course you do, though."

"Yes," said the president, nodding thoughtfully; "I understand, thou understandest, she understands — meaning Miss Burnham — possibly also Maugydoodle, if I do not mistake



"THE OFFICER WAS SEWING BY THE WINDOW."

the attentive expression of her back hair. "Go on!"

But the secretary did not go on at once. She was thinking. The secretary was a very ambitious girl; and the musical ability which made her so desirable a conductor for the symphony, was of less importance in her own eyes than the literary talent which she also possessed, and which caused her to yearn ardently for literary honors. To be chosen as the representative of her class in the coming debate with the girls of the Burton Academy, — this was the glory she dreamed of; and this glory was to be

conferred upon that girl whose work in the several appointed trial-debates should win the highest vote of her companions.

Miss Burnham herself was interested in the contest. The secretary's chances were good. And now —

"If I don't do my best in the trial-debates," said the secretary, aloud, "I shall lose my chance of being chosen, you know." It sounded selfish, but she said it. "The symphony will take a deal of practice, if we are to do it well; and if I spend my extra time rehearsing with the girls, where is all the hard work I have done, and must do yet, to get ready for the debates?"

"Sounds like Peter Piper," mused the president, quaintly, her elbows on her knees. "Dora Darrow did a lot of dreadful study. *If* Dora Darrow did a lot of dreadful study, *where*'s the lot of dreadful study Dora Darrow did?"

She was such a dear, delightful girl, in her whimsical way, that the secretary felt her resolution slipping fast. She looked severely at her mending, and went on, making a fresh start.

"I have often thought," she said, "that the club took up too much of our time, anyway!"

"You!" cried the president, in grieved astonishment. "You disapprove of the club, when it exists for the very purpose of improving our minds and morals and everything else that is Dody-ish and desirable! We don't debate, to be sure; but we do try to do a little good. And I give you my word — we have at this moment in the treasury but two cents to do it with. We pledged ourselves to take care of the Sclavoni family till summer, and how can we — I ask you as a friend — how can we do it on two cents? Whereas, if we sell one hundred tickets for the symphony, we shall have one hundred dollars, Dora Darrow! And the glory — and the fun — and the ice-cream, — Miss Burnham says we may, — and, oh, Dody, dancing afterward!"

Again she was so adorable in her girlish rapture that the secretary was obliged to hold herself in more firmly than ever.

"Dody," — she leaned both round arms upon her friend's knee, — "you are the cleverest girl in school! You know you could beat everybody at the debates, and lead the symphony, too, just as well as not, if you only wanted to; and

no one can make that symphony a success except you!"

"Nonsense!" returned the secretary, hard-pressed but resolute.

The president plucked the unparliamentary bonnet from her head, and cast it upon the floor.

"Then it's all up with us!" she declared, tragically. "The Sclavonis will die of cold and hunger, and the rest of us will perish of ennui, which is just as bad! and you promised, Dody, — you promised, if I came to school with you, that you would be — kind — to me! You said it did n't matter if I *was* a stupid little thing — we would do everything — together —" The president's voice broke. Her mouth quivered with pathos. Her hand went out for her little pocket-handkerchief, and failing this, seized upon the pink sunbonnet, and pressed it, a crumpled rose, to the rose of her tear-wet cheek.

This time her argument was irresistible. To work a little harder, thought Dora, to have a little less time for recreation, — was this too much to do for one's dearest friend, and that friend the dearest girl in the world?

"When," said the secretary, suddenly, "when shall we have the first rehearsal?"

"Maugydoodle!" cried the president, dancing out of the room a few minutes later, and seeing that young person's pale and eager little face still gazing silently from her dusky corner — "Maugydoodle, if you're awfully, terribly good every single minute from now till then, we're going to let you and Polly play the little wind-things in the symphony! Is n't that an honor? By-by, Dora darling!"

II.

"*One, two, three! One, two, three!*"

The secretary's little wand beat out the time, sharply, persistently.

"*One, two, three!*" The Drum was off the count again, and banged away with untimely zeal on the wrong note, bar after bar, followed with stupid devotion by the Cymbals. The Quail had lost her place, and determined that nothing should induce her to admit the fact, piped persistently, in season and out of season,

regardless of the efforts of the Cuckoo, who sat next her, and who showed a soaring though mistaken ambition to outplay the entire orchestra. The "little wind-things" burred and chirred whenever the conductor cast an unwary glance in their direction. The Nightingale had bubbled itself out of water, and refused to emit anything but a dismal squeak in response to the most frantic efforts. Only the piano kept on its way, undisturbed.

The secretary rapped sharply on her stand, "We will begin back at G," she commanded, pushing the hair from her hot face. "All the instruments count sixteen bars before coming in."



"SHE WAS PLAYING
THE 'MELODY IN F.'"

The piano gave out the melody, softly. Ah, that was playing! No wonder the president loved her piano. It responded to her touch as if it loved her, sure, spirited, beautiful. It sang, it rippled, it stormed, as she chose to have it. She looked up with eyes full of mischievous laughter to meet the secretary's anguished glance, as the instruments straggled in among the bars, like a flock of timid sheep into a forbidden meadow.

They began at G again. The secretary went down and found their places for them, patiently. She went back and beat the time, hopefully.

"One, two, three! All together now!" On the key or off, in time or out—bang! crash! gurgle! *cuckoo! cuckoo! cuckoo!* squeak!

"It will come out all right in time," encouraged the president, gathering up her music when the rehearsal was over; "when they once get the knack of it, you know!"

The exhausted secretary did not answer. She went up to her own room and shut the door. She sat down by the window and dropped her chin in her hands and thought.

If this went on much longer something was going to break. When she studied up for her debates, she was thinking about the symphony; and when she led the symphony, she was thinking about the debates. It was no use. One thing she could do successfully, but not both. She had tried hard, because she could not bear to disappoint Alice. But when one's reason began to give way—"Cuckoo! cuckoo! squeak!" The chirp of that idiotic bird rang in her ears with maddening insistence.

Alice *would* be disappointed, of course. To her the success of the symphony meant a great deal. But then, why should Alice always be the one to be considered? Other people had wishes to be gratified, too. The honor of representing the class in the Burton Debate—that was something worth working for, a serious and lofty achievement, a satisfaction, a delight. Oh, yes, the symphony must go! She would run and tell Alice at once; and somebody else could take the conductor's place,—they would manage to get through it some way,—they *must!*

She went quickly to the door and opened it. The sound of a piano came floating up from below. That was Alice, now. She was playing the "Melody in F." What a touch she had! What a note of freshness, of joy, of triumph, rang out in the buoyant measure! It was like spring, like the budding of the lilacs in the garden, like Alice herself.

Something deep, true, sweet, in the girl spoke through her music, under all the daintiness, the wayward and wilful charm. Listening, the secretary felt her heart swell with a great wave of tenderness toward the friend she loved. She

could almost hear the whimsical, grave voice repeating: "If Dora Darrow did a lot of dreadful study, *where 's* the lot of dreadful study —"

Something entered into her mind, breaking her thought off in the middle; something in Latin, that she knew well, but had forgotten for the moment — "Alter ipse amicus," that was it: "A friend is another self." It was the motto of the club. She and the president had chosen it together, and the girls had accepted it gladly as a pledge of their loyalty and devotion to each other.



"'CHILD,' SHE SAID STERNLY, 'WHAT ARE YOU DOING HERE?'"

If that motto meant anything, it meant that Alice's triumph was as much to her friend as her own; that any success won at the price of Alice's happiness and confidence would be worse than a failure.

The secretary caught her breath. Why, of course it would! What had she been thinking about? What if the symphony had seemed to her an unnecessary, a frivolous thing? Alice wanted it; Alice counted on her, trusted her. All the praise and honor in the world could not make up for the loss of that trust. She saw herself suddenly, standing proud and glowing with her triumph, and Alice's face looking out at her, grieved and sober, under the rosy shadow of the pink sunbonnet.

That was enough. A few minutes later she stood knocking at the door of Miss Burnham's room.

III.

ONLY Miss Molly was there, writing at the desk. That was lucky. Miss Molly's eyes were kind and vague, not keen and compelling

like her sister's. It was quite easy to make her understand that honors were a matter of great indifference to some people, and that, as for this particular affair, the secretary, being rather tired and very busy with her lessons, had decided to give up all thought of representing her class in the contest with the Burton Academy girls, and so not to join in the trial-debates.

Miss Molly was sorry. But she knew that the secretary could be trusted as to the reasons for her withdrawal.

"You wish to be left out entirely, then, Dora?" she said, with regret.

"If you please," said the secretary, with decision. And Miss Molly crossed off the name of Dora Darrow from a list upon her desk.

The matter being thus happily settled, the secretary went up-stairs again, much relieved and humming a little tune under her breath. True, her knees felt a trifle weak, and she hardly noticed a small form which crept out upon her from some unexpected corner; but, winking hastily and hard, she perceived it to be the form of Maugydoodle. Whereupon she suppressed an unwonted desire to shake that ever-present young person.

"Child," she said sternly, "what are you doing here?"

But Maugydoodle, having no answer ready, only embraced her fervently about the knees, and shook her small head with a shrewd look of understanding and sympathy which the secretary fortunately did not see.

IV.

THAT was Thursday. The president was going home the next day, to spend Sunday. There was to be a party at the home of one of her friends on Friday night. She was all dimples and delight when the secretary kissed her good-by — rather hurriedly, for fear of possible questions.

A rehearsal of the symphony had been appointed for that afternoon, and the first of the trial-debates was to take place the following morning. The president would, luckily enough, be out of the way.

"I hope everything will go well," she said, jabbing a reckless hat-pin into her picture-hat.

"Becky Ford can play the piano—for once, and I shall be back early Monday. Good-by, Dora darling. Is my hat on straight?"

Straight? Of course not. The president's hats were always on crooked, bless her! How radiant she was under her drooping feathers! How good it was to see her so radiant and so happy!

The secretary did not wait to see her off. She ran down-stairs to study awhile in one of the class-rooms, and then went to meet the club in another for the symphony rehearsal.

This time she put her whole heart into the work. The players felt the new spirit in the hand that led them, and rose heroically to the charge. They were all there except one of the little wind-things, who straggled in late with a guilty expression, and hurred and chirred with double vigor to make up for it.

Becky Ford made superhuman efforts at the piano. The Quail kept her place for three consecutive pages without a break. The Drum roared—in the right places—as gently as any sucking-dove. The secretary's spirits rose. When she heard the whistle of the president's departing train, she drew a long breath of relief, and led the attack on "G" with fervor and enthusiasm.

"One, two, three!" Gurgle! bang! chir-r! cuckoo! cuckoo! squeak!

Things were going famously. They were trying it for the last time. Then suddenly the music was snapped and shattered as by an earthquake. All the instruments ran amuck for one wild second, and then stopped.

The secretary looked at them astonished. What had happened? Polly and Maud, who sat nearest her, dropped the little wind-things and pointed their fingers at the door behind her.

The secretary turned slowly. On the threshold stood the president. She was still in her hat and jacket, her face demure and sparkling, her hands folded with an air of mingled meekness and triumph bewildering to behold.

"Alice—Heath—Dunbar!" exclaimed the secretary.

"Dody!" said the president.

It was not much of an explanation; but with the tone of the president's voice and the look in her eyes, it was enough for the secretary.

"My dear!"—she began, coming down from the platform.

"No," said the president, waving her off. "Not 'dear' at all! Selfish, thoughtless, horrid,—anything but dear! But don't tell me you thought I was as bad as that, Dora Darrow! Don't, because I won't believe it! I never thought—I never for one moment dreamed—"

"You've lost your train!" said the secretary, breathless. "You've missed your party!"

"Goose!" returned the president. "As if a hundred million parties were of any conse-



"GOOD-BY, DORA DARLING. IS MY HAT ON STRAIGHT?"

quence, compared with your losing the desire of your heart! You meant to lose it—you meant to skip your old trial-debates to-morrow, and go and break my heart when I was n't here to know it was being broken! You know you did—don't tell me! But, oh, Dody,"—she caught both the secretary's hands in hers suddenly, with a little catch in her voice which was not quite a laugh nor yet wholly a sob,—“oh, Dody, you *know* I would n't have let you, if I had guessed, my dear!”

If she had been radiant before, under her drooping feathers, how much more radiant she was now, with that tender brightness in her eyes and that laughing quiver on her

lips! If she had been lovable before, in her own wilful way, how much more lovable she was now, with the earnestness and the sweetness



"ON THE THRESHOLD STOOD THE PRESIDENT."

that were in her shining up under all her pretty sparkle!

The secretary would have hugged her on the spot, but the president retreated from her affectionate arms.

"We shall have to resign, you know," she said, dabbing briskly at her eyes. "The girls will never speak to us again for deserting them this way; but we can't help that! We'll give up the symphony right here and now, before the examination to-morrow, and then we'll both resign—"

"*Cuckoo! cuckoo!*"

The hoarse call of that irrepressible bird broke forth again at this moment amid a babel of impatient voices.

The president sprang to the platform and called the meeting to order. In a two-minute speech she made plain the situation, and offered the resignations of herself and the secretary.

"I move, Madam President," cried the Night-

ingale, before she had fairly finished, "that we decline those resignations! I move that the symphony be postponed till—till the—well, anyway, till after the debates are over, and Dora has won the honors! Nobody else can lead, and nobody but Alice—I mean Madam President—can play the piano, and—"

"Second the motion!" cried the Drum. "All in favor—I beg pardon, Madam President!—all in favor, say—"

There was a unanimous "Aye" from the entire club; and Miss Molly, who was passing the door, came running in to find out what on earth was the matter.

But the president and the secretary, bowing acknowledgments from the platform, knew that henceforth the motto of The Merry Maids would never be to them an empty phrase, but the expression

of a truth, deep and beautiful, which they had proved and tested for themselves.

"By the way," said the secretary, going up-stairs with her arm around the president's waist, "how did you happen to find out?"

"Maugydoodle," said the president, concisely. "Maugydoodle came up to my room and told me, just as I was ready to start."

"The blessed little—pitcher with big ears! I move," said the secretary, forgetting for the moment

that the club was not in session, "that Maugydoodle be restored to her rightful name, and made an honorary member—*mem-borv*, I mean—of The Merry Maids!"

And so she was.



"SECOND THE MOTION!" CRIED THE DRUM.

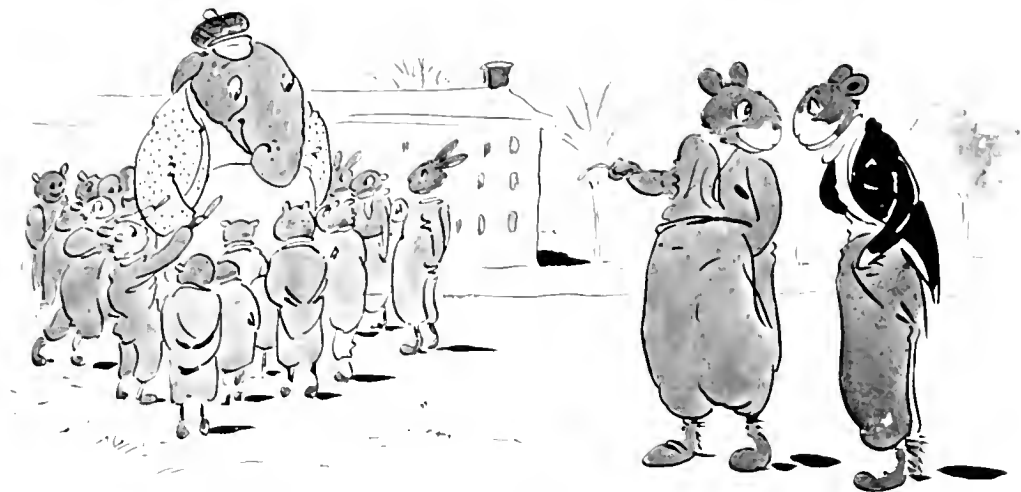

"THE NEW MAN SEEMS VERY POPULAR; SEE HOW THEY CROWD AROUND HIM!"
"YES, THEY ARE TRYING TO GET HIM TO PLAY ON THE FOOT-PATH TEAM."

QUEEN ZIXI OF IX.

Copyright, 1915, by L. FRANK BAUM.

By L. FRANK BAUM,
Author of "The Wizard of Oz."

CHAPTER XXI.

THE SEARCH FOR THE MAGIC CLOAK.

THE sun had scarcely risen next morning when our friends left the city of IX in search of the magic cloak. All were mounted on strong horses, with a dozen soldiers riding behind to protect them from harm, while the royal steward of the witch-queen followed with two donkeys laden with hampers of provisions from which to feed the travelers on their way.

It was a long journey to the wide river, but they finally reached it, and engaged the ferryman to take them across. The ferryman did not like to visit the other shore, which was in the kingdom of Noland; for several of the Roly-Rogues had already been seen upon the mountain-top. But the guard of soldiers reassured the man; so he rowed his big boat across with the entire party, and set them safely on the

shore. The ferryman's little daughter was in the boat, but she was not sobbing to-day. On the contrary, her face was all smiles.

"Do you not still wish to be a man?" asked Zixi, patting the child's head.

"No, indeed!" answered the little maid. "For I have discovered all men must work very hard to support their wives and children, and to buy them food and raiment. So I have changed my mind about becoming a man, especially as that would be impossible."

It was not far from the ferry to the grove of lilacs, and as they rode along Zixi saw the gray owl sitting contentedly in a tree and pruning its feathers.

"Are you no longer wailing because you cannot swim in the river?" asked the witch-queen, speaking in the owl language.

"No, indeed," answered the gray owl. "For, as I watched a fish swimming in the water, a

man caught it on a sharp hook, and the fish was killed. I believe I 'm safer in a tree."

"I believe so, too," said Zixi, and rode along more thoughtfully; for she remembered her own desire, and wondered if it would also prove foolish.

Just as they left the river-bank she noticed the old alligator sunning himself happily upon the bank.

"Have you ceased weeping because you cannot climb a tree?" asked the witch-queen.

"Of course," answered the alligator, opening one eye to observe his questioner. "For a boy climbed a tree near me yesterday and fell out of it and broke his leg. It is quite foolish to climb trees. I 'm sure I am safer in the water."

Zixi made no reply, but she agreed with the alligator, who called after her sleepily:

"Is n't it fortunate we cannot have everything we are stupid enough to wish for?"

Shortly afterward they left the river-bank and approached the lilac-grove, the witch-queen riding first through the trees to show the place where she had dropped the magic cloak. She knew it was near the little spring where she had gazed at her reflection in the water; but, although they searched over every inch of ground, they could discover no trace of the lost cloak.

"It is really too bad!" exclaimed Zixi, with vexation. "Some one must have come through the grove and taken the cloak away."

"But we must find it," said Bud, earnestly; "for otherwise I shall not be able to rescue my people from the Roly-Rogues."

"Let us inquire of every one we meet if they have seen the cloak," suggested Princess Fluff. "In that way we may discover who has taken it."

So they made a camp on the edge of the grove, and for two days they stopped and questioned all who passed that way. But none had ever seen or heard of a cloak like that described.

Finally an old shepherd came along, hobbling painfully after a flock of five sheep; for he suffered much from rheumatism.

"We have lost a beautiful cloak in the lilac-grove," said Zixi to the shepherd.

"When did you lose it?" asked the old man, pausing to lean upon his stick.

"Several days ago," returned the queen. "It was bright as the rainbow, and woven with threads finer than —"

"I know, I know!" interrupted the shepherd, "for I myself found it lying upon the ground beneath the lilac-trees."

"Hurrah!" cried Bud, gleefully; "at last we have found it!" And all the others were fully as delighted as he was.

"But where have you put the cloak?" inquired Zixi.

"Why, I gave it to Dame Dingle, who lives under the hill yonder," replied the man, pointing far away over the fields; "and she gave me in exchange some medicine for my rheumatism, which has made the pain considerably worse. So to-day I threw the bottle into the river."

They did not pause to listen further to the shepherd's talk, for all were now intent on reaching the cottage of Dame Dingle.

So the soldiers saddled the horses, and in a few minutes they were galloping away toward the hill. It was a long ride, over rough ground; but finally they came near the hill and saw a tiny, tumbledown cottage just at its foot.

Hastily dismounting, Bud, Fluff, and the queen rushed into the cottage, where a wrinkled old woman was bent nearly double over a crazy-quilt upon which she was sewing patches.

"Where is the cloak?" cried the three, in a breath.

The woman did not raise her head, but counted her stitches in a slow, monotonous tone.

"Sixteen — seventeen — eighteen —"

"Where is the magic cloak?" demanded Zixi, stamping her foot impatiently.

"Nineteen —" said Dame Dingle, slowly. "There! I 've broken my needle!"

"Answer us at once!" commanded Bud, sternly. "Where is the magic cloak?"

The woman paid no attention to him whatever. She carefully selected a new needle, threaded it after several attempts, and began anew to stitch the patch.

"Twenty!" she mumbled in a low voice; "twenty-one —"

But now Zixi snatched the work from her hands and exclaimed:

"If you do not answer at once I will give you a good beating!"



"SO, INDEED," ANSWERED THE GRAY OWL. "I BELIEVE I AM SAFER IN A TREE!"

"That is all right," said the dame, looking up at them through her spectacles; "the patches take twenty-one stitches on each side, and if I lose my count I get mixed up. But it's all right now. What do you want?"

"The cloak the old shepherd gave you," replied the queen, sharply.

"The pretty cloak with the bright colors?" asked the dame, calmly.

"Yes! Yes!" answered the three, excitedly.

"Why, that very patch I was sewing was cut from that cloak," said Dame Dingle. "Is n't it lovely? And it brightens the rest of the crazy-quilt beautifully."

"Do you mean that you have cut up my magic cloak?" asked Fluff, in amazement, while the others were too horrified to speak.

"Certainly," said the woman. "The cloak was too fine for me to wear, and I needed something bright in my crazy-quilt. So I cut up half of the cloak and made patches of it."

The witch-queen gave a gasp, and sat down suddenly upon a rickety bench. Princess

Fluff walked to the door and stood looking out, that the others might not see the tears of disappointment in her eyes. Bud alone stood scowling in front of the old dame, and presently he said to her, in a harsh tone:

"You ought to be smothered with your own crazy-quilt for daring to cut up the fairy cloak!"

"The fairy cloak!" echoed Dame Dingle. "What do you mean?"

"That cloak was a gift to my sister from the fairies," said Bud; "and it had a magic charm. Are n't you afraid the fairies will punish you for what you have done?"

Dame Dingle was greatly disturbed.

"How could I know it?" she asked, anxiously; "how could I know it was a magic cloak that old Edi gave to me?"

"Well, it was; and woven by the fairies themselves," retorted the boy. "And a whole nation is in danger because you have wickedly cut it up."

Dame Dingle tried to cry, to show that she

was sorry and so escape punishment. She put her apron over her face, and rocked herself back and forth, and made an attempt to squeeze a tear out of her eyes.

Suddenly Zixi jumped up.

"Why, it is n't so bad, after all!" she exclaimed. "We can sew the cloak together again."

"Of course!" said Fluff, coming from the doorway. "Why did n't we think of that at once?"

"Where is the rest of the cloak?" demanded Zixi.

Dame Dingle went to a chest and drew forth the half of the cloak that had not been cut up. There was no doubt about its being the magic cloak. The golden thread Queen Lulea had woven could be seen plainly in the web, and the brilliant colors were as fresh and lovely as ever. But the flowing skirt of the cloak had been ruthlessly hacked by Dame Dingle's shears, and presented a sorry sight.

"Get us the patches you have cut!" com-

manded Zixi; and without a word the dame drew from her basket five small squares and then ripped from the crazy-quilt the one she had just sewn on.

"But this is n't enough," said Fluff, when she had spread the cloak upon the floor and matched the pieces. "Where is the rest of the cloak?"

"Why,—why —" stammered Dame Dingle, with hesitation, "I gave them away."

"Gave them away! Who got them?" said Bud.

"Why,—some friends of mine were here from the village last evening, and we traded patches, so each of us would have a variety for our crazy-quilts."

"Well?"

"And I gave each of them one of the patches from the pretty cloak."

"Well, you *are* a ninny!" declared Bud, scornfully.

"Yes, your Majesty; I believe I am," answered Dame Dingle, meekly.

"We must go to the village and gather up

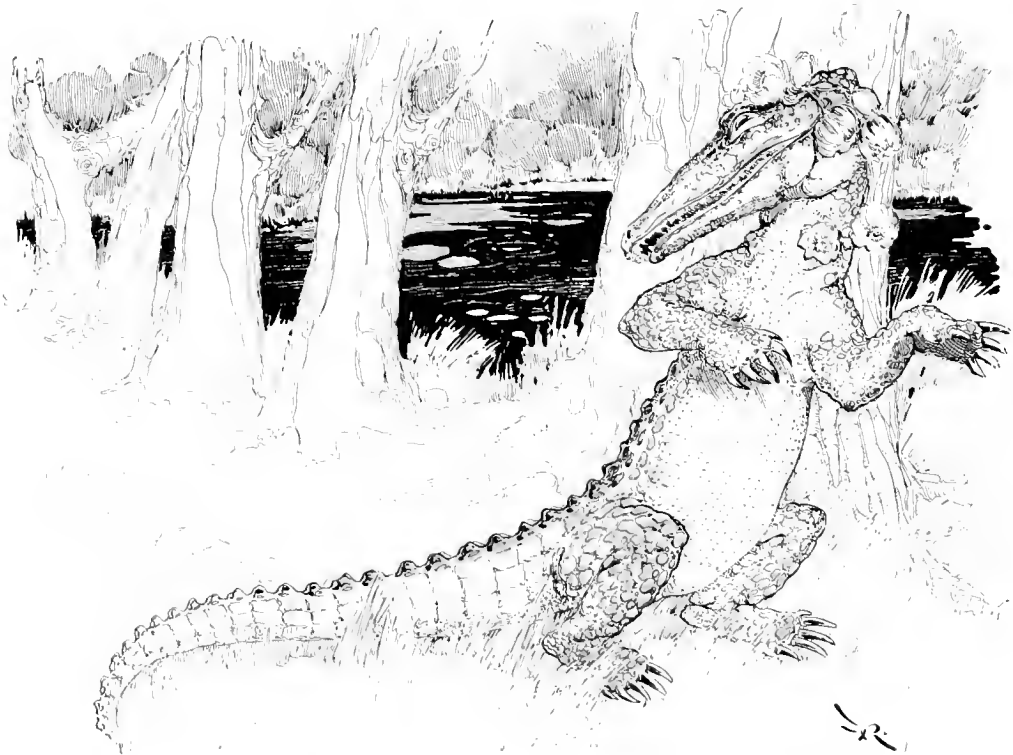

"OF COURSE," ANSWERED THE ALLIGATOR, OPENING ONE EYE TO OBSERVE HIS QUESTIONER."

those pieces," said Zixi. "Can you tell us the names of your friends?" she asked the woman.

"Of course," responded Dame Dingle; "they were Nancy Nink, Betsy Barx, Sally Sog, Molly Mitt, and Lucy Lum."

"Before we go to the village let us make Dame Dingle sew these portions of the cloak together," suggested Fluff.

The dame was glad enough to do this, and she threaded her needle at once. So deft and fine was her needlework that she mended the cloak most beautifully, so that from a short distance away no one could discover that the cloak had been darned. But a great square was still missing from the front, and our friends were now eager to hasten to the village.

"This will cause us some delay," said the witch-queen, more cheerfully; "but the cloak will soon be complete again, and then we can have our wishes."

Fluff took the precious cloak over her arm, and then they all mounted their horses and rode away toward the village, which Dame Dingle pointed out from her doorway. Zixi was sorry for the old creature, who had been more foolish than wicked; and the witch-queen left a bright gold piece in the woman's hand when she bade her good-by, which was worth more to Dame Dingle than three pretty cloaks.

The ground was boggy and uneven, so they were forced to ride slowly to the little village; but they arrived there at last, and began hunting for the old women who had received pieces of the magic cloak. They were easily found, and all seemed willing enough to give up their patches when the importance of the matter was explained to them.

At the witch-queen's suggestion, each woman fitted her patch to the cloak and sewed it on very neatly; but Lucy Lum, the last of the five, said to them:

"This is only half of the patch Dame Dingle gave me. The other part I gave to the miller's wife down in the valley where the river bends. But I am sure she will be glad to let you have it. See—it only requires that small piece to complete the cloak and make it as good as new."

It was true—the magic cloak, except for a small square at the bottom, was now complete;

and such skilful needlewomen were these crazy-quilt makers that it was difficult to tell where it had been cut and afterward mended.

But the miller's wife must now be seen; so they all mounted the horses again, except Aunt Rivette, who grumbled that so much riding made her bones rattle and that she preferred to fly. Which she did, frightening the horses to such an extent with her wings that Bud made her keep well in advance of them.

They were all in good spirits now, for soon the magic cloak, almost as good as new, would be again in their possession; and Fluff and Bud had been greatly worried over the fate of their friends who had been left to the mercy of the terrible Roly-Rogues.

The path ran in a zigzag direction down into the valley; but at length it led the party to the mill, where old Rivette was found sitting in the doorway awaiting them.

The miller's wife, when summoned, came to them drying her hands on her apron, for she had been washing the dishes.

"We want to get the bright-colored patch Lucy Lum gave you," explained Fluff; "for it was part of my magic cloak, which the fairies gave to me, and this is the place where it must be sewn to complete the garment." And she showed the woman the cloak, with the square missing.

"I see," said the miller's wife, nodding her head; "and I am very sorry I cannot give you the piece to complete your cloak. But the fact is, I considered it too pretty for my crazy-quilt, so I gave it to my son for a necktie."

"And where is your son?" demanded Zixi.

"Oh, he is gone to sea, for he is a sailor. By this time he is far away upon the ocean."

Bud, Fluff, and the witch-queen looked at one another in despair. This seemed, indeed, to destroy all their hopes; for the one portion of the cloak that they needed was far beyond their reach.

Nothing remained but for them to return to Zixi's palace and await the time when the miller's son should return from his voyage. But before they went the queen said to the woman:

"When he returns you may tell your son that if he will bring to me the necktie you gave him, I will give him in return fifty gold pieces."

"And I will give him fifty more," said Bud, promptly.

"And I will give him enough ribbon to make fifty neckties," added Fluff.

The miller's wife was delighted at the prospect.

ing the necktie, that she left two of her soldiers at the mill, with instructions to bring the man to her palace the instant he returned home.

As they rode away they were all very despondent over the ill luck of their journey.



"WHERE IS THE CLOAK?" CRIED THE THREE, IN A BREATH.

"Thank you! Thank you!" she exclaimed. "My boy's fortune is made. He can now marry Imogene Gulb and settle down on a farm, and give up the sea forever! And his neckties will be the envy of all the men in the country. As soon as he returns I will send him to you with the bit of the cloak which you need."

But Zixi was so anxious that nothing might happen to prevent the miller's son from return-

"He may be drowned at sea," said Bud.

"Or he may lose the necktie on the voyage," said Fluff.

"Oh, a thousand things *might* happen," returned the queen; "but we need not make ourselves unhappy imagining them. Let us hope the miller's son will soon return and restore to us the missing patch." Which showed that Zixi had not lived six hundred and eighty-three years without gaining some wisdom.

CHAPTER XXII.

RUFFLES CARRIES THE SILVER VIAL.

WHEN they were back at the witch-queen's palace in the city of IX, the queen insisted that Bud and Fluff, with their Aunt Rivette, should remain her guests until the cloak could be restored to its former complete state. And, for fear something else might happen to the precious garment, a silver chest was placed in Princess Fluff's room and the magic cloak safely locked therein, the key being carried upon the chain around the girl's neck.

But their plans to wait patiently were soon interfered with by the arrival at Zixi's court of

came so cross and disagreeable that even Zixi was provoked with him,

"Something really must be done," declared the queen. "I'll brew a magical mess in my witch-kettle to-night, and see if I can find a way to destroy those detestable Roly-Rogues."

Indeed, she feared the creatures would some day find their way into IX; so when all the rest of those in the palace were sound asleep, Zixi worked her magic spell, and from the imps she summoned she obtained advice how to act in order to get rid of the Roly-Rogues.

Next morning she questioned Ruffles carefully.

"What do the Roly-Rogues eat?" she asked.

"Everything," said the dog; "for they have

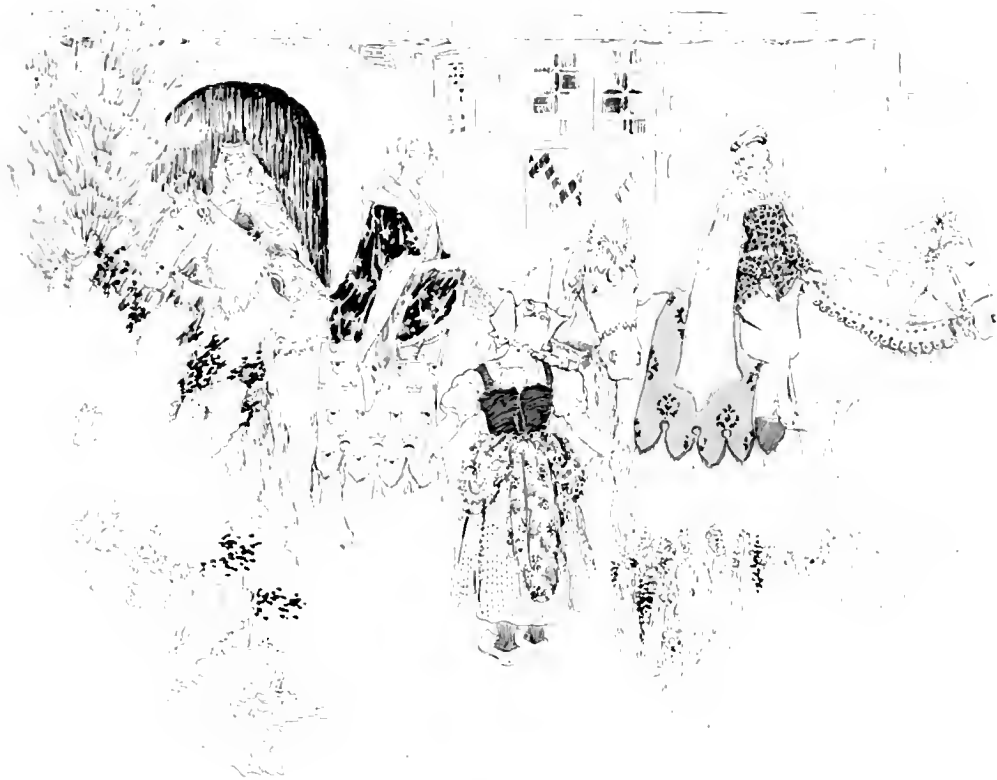

"AND WHERE IS YOUR SON?" DEMANDED ZIXI!

the talking dog, Ruffles, which had with much difficulty escaped from the Roly-Rogues.

Ruffles brought to them so sad and harrowing a tale of the sufferings of the five high counselors and all the people of Noland at the hands of the fierce Roly-Rogues, that Princess Fluff wept bitterly for her friends, and Bud be-

no judgment, and consume buttons and hairpins as eagerly as they do food. But there is one thing they are really fond of, and that is soup. They oblige old Tollydob, the lord high general, who works in the palace kitchen, to make them a kettle of soup every morning; and this they all eat as if they were half starving."

"Very good!" exclaimed the witch-queen, with pleasure. "I think I see a way of ridding all Noland of these monsters. Here is a Silver Vial filled with a magic liquid. I will tie it around your neck, and you must return to the city of Nole and carry the vial to Tollydob, the lord high general. Tell him that on Thursday morning, when he makes the kettle of soup, he must put the contents of the vial into the compound. But let no one taste it afterward except the Roly-Rogues."

"And what then?" asked Ruffles, curiously.

"Then I will myself take charge of the monsters; and I have reason to believe the good

bid me; for I long to free my master and have revenge on the Roly-Rogues."

So Queen Zixi tied the Silver Vial to the dog's neck by means of a broad ribbon, and he started at once to return to Nole.

And when he had gone, the queen summoned all her generals and bade them assemble the entire army and prepare to march into Noland again. Only this time, instead of being at enmity with the people of Noland, the army of IX was to march to their relief; and instead of bearing swords and spears, each man bore a coil of strong rope.

"For," said Zixi, "swords and spears are useless where the Roly-Rogues are concerned,



"QUEEN ZIXI TIED THE SILVER VIAL TO THE DOG'S NECK."

citizens of Noland will no longer find themselves slaves."

"All right," said the dog. "I will do as you

as nothing can pierce their tough, rubber-like bodies. And more nations have been conquered by cunning than by force of arms."

Bud and Fluff, not knowing what the witch-queen meant to do, were much disturbed by these preparations to march upon the Roly-

"Why not try the magic cloak as it is," suggested the little princess, "and see if it won't grant wishes as before? There's only a



FIGURE 1.

"AND MAY I WISH FOR ANYTHING I DESIRE?" SHE ASKED EAGERLY. (SEE PAGE 274.)

Rogues. The monsters had terrified them so greatly that they dreaded to meet with them again, and Bud declared that the safest plan was to remain in Zixi's kingdom and await the coming of the miller's son with the necktie.

"But," remonstrated Zixi, "in the meantime your people are suffering terribly."

"I know," said Bud; "and it nearly drives me frantic to think of it. But they will be no better off if we try to fight the Roly-Rogues and are ourselves made slaves."

small piece missing, and it may not make any difference with the power the fairies gave to it."

"Hooray!" shouted Bud. "That's a good idea. It's a magic cloak just the same, even if there is a chunk cut out of it."

Zixi agreed that it was worth a trial, so the cloak was taken from the silver casket and brought into the queen's reception-room.

"Let us try it on one of your maids of honor, first," said Fluff; "and, if it grants her wish, we will know the cloak has lost none of its

magic powers. Then you and Bud may both make your wishes."

"Very well," returned the queen, and she summoned one of her maids.

"I am going to lend you my cloak," said the princess to the maid; "and while you wear it you must make a wish."

She threw the cloak over the girl's shoulders, and after a moment's thought the maid said:

"I wish for a bushel of candies."

"Fudge!" said Bud, scornfully.

"No; all kinds of candies," answered the maid of honor. But, although they watched her intently, the wish failed, for no bushel of candies appeared in sight.

"Let us try it again," suggested Fluff, while the others wore disappointed expressions. "It was a foolish wish, anyhow; and perhaps the fairies did not care to grant it."

So another maid was called and given the cloak to wear.

"And may I wish for anything I desire?" she asked eagerly.

"Of course," answered the princess; "but,

as you can have but one wish, you must choose something sensible."

"Oh, I will!" declared the maid. "I wish I had yellow hair and blue eyes."

"Why did you wish that?" asked Fluff, angrily, for the girl had pretty brown hair and eyes.

"Because the young man I am going to marry says he likes blondes better than brunettes," answered the maid, blushing.

But her hair did not change its color, for all the wish; and the maid said, with evident disappointment:

"Your magic cloak seems to be a fraud."

"It does not grant foolish wishes," returned the princess, as she dismissed her.

When the maid had gone Zixi asked:

"Well, are you satisfied?"

"Yes," acknowledged Fluff. "The cloak will not grant wishes unless it is complete. We must wait for the sailorman's necktie."

"Then my army shall march to-morrow morning," said the queen, and she went away to give the order to her generals.

(To be concluded.)



F. RICHARDSON

"HE STARTED AT ONCE TO RETURN TO NOLE."

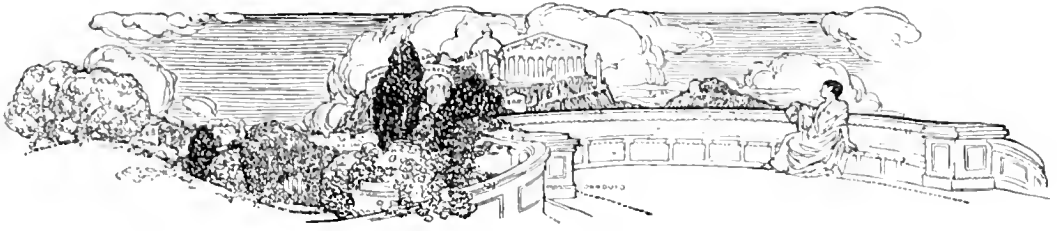

A LITTLE TALK ABOUT ARCHITECTURE.

BY LUCIA AMES MEAD.

ALMOST as much can be learned about ancient nations from looking at what they made or built as by reading their writings and inscriptions. For the kind of buildings that any nation erected depended on several different things—climate, geography, building materials, religion, and government.

People in snowy Scotland, for instance, needed very different buildings from those who lived in sunny Italy. Some countries had forests and built many wooden houses, others had great quarries and so made use of massive stone, and other countries that had little stone or wood but had great beds of clay, like ancient Assyria, built their palaces and temples of burnt clay made into bricks. People who lived among the mountains or by the sea, as did the people of Greece and Italy, built differently from those who lived on the level plains of Asia or Africa. Some nations had many gods and built temples for the kind of worship that their particular religion required. Christian nations lavished their skill and money on grand cathedrals, convents, and cloisters.

In countries where the ruler was a despot, great palaces were built by slaves, but where there was no great monarch, as in ancient Greece, there were no grand private buildings, but the finest work was put into great public buildings for the people.

Yes, if all the books and records in the world were burned we should still be able to trace the customs and ideas of ancient nations by the structures and works of art that they have left.

In Egypt and Palestine the climate was warm, and consequently homes were built with flat roofs, on which the dwellers could sit in the eve-

ning; whereas in snowy regions houses were built with slanting roofs to shed snow and rain. In Egypt were few trees or brooks or clouds—only a wide, sandy plain, a great river, and an immense, unbroken arch of blue sky. The architecture was on an immense and simple scale, just like the scenery. As the ancient religion laid great stress on immortality and it was thought very important to preserve the mummies of the dead, enormous tombs were among the chief structures. Great quarries of building-stone, hordes of slaves, and one great despot ruling over all made it possible to build the temples



EGYPTIAN STYLE OF ARCHITECTURE

and huge pyramids. From paintings and carvings on the temples and tombs one may learn a great deal more about how these wonderful Egyptians lived and dressed and carried on their trades and commerce than any of their writings could tell us.

Neither the Egyptians nor any peoples in

Africa or Asia have influenced very much the present architecture and decoration of the nations in Europe. Each of the Persian, East Indian, Chinese, and Japanese nations had an

Greek art was very different from Egyptian, for the country of Greece and the religion and government and customs of the Greeks were different from those of the Egyptians. Greece had no great desert or great river. The Greeks were unlike the Egyptians, too, in not caring as much for huge, strong things as for delicate, beautiful ones. Their art was in keeping with their snow-capped peaks and rosy clouds, and groves and brooks and mossy fountains. There never was a people with a greater love for exquisite curves and noble proportions.

Their quarries of fine, white marble gave them just the right material into which they could cut firm and delicate lines. Their freer government encouraged every man to work out his own thoughts, as the slaves who built the pyramids under a master's whip could never have done.

If we want to enjoy our fine public buildings and to get much pleasure as we walk along the street we need to know enough to recognize

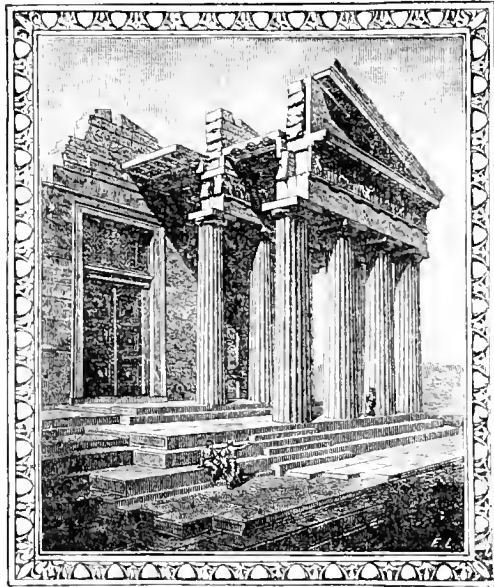

THE DORIC STYLE OF ARCHITECTURE.

interesting art of its own, but Europeans, as a whole, did not know much about it until the nineteenth century. Now we have the wares of all these peoples in our shops, though we do not often imitate their buildings.

As we go through the handsome streets of the rich cities of America we behold many costly houses, some beautiful and some only showy, and not beautiful. Any one who knows the history of art is much interested to see how all over them, in their pillars and arches, and cornices and roofs, there are designs and forms which the architect did not invent, but which were first made over two thousand years ago in Greece and Rome.

Not only are half of our English words and a great many of our laws and customs and ideas founded on those of the ancient Greeks and Romans, but so are our architecture and decoration. If we wish to understand ourselves we must know a great deal about the Romans and Greeks; just as if we wish to know all about a man we must know something about his father and the home in which he was brought up.



THE CORINTHIAN ORDER OF ARCHITECTURE.

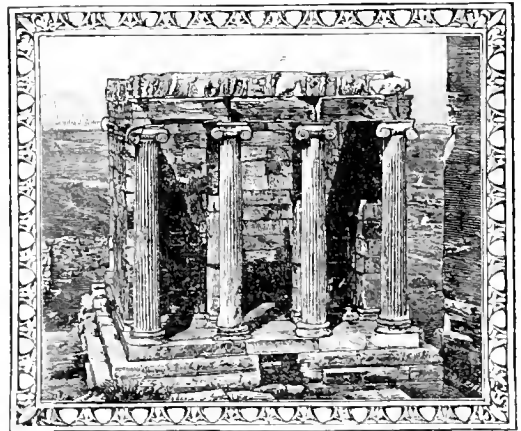

THE IONIC STYLE OF ARCHITECTURE.

some of the beautiful designs that our architects have copied from those the Greeks invented twenty-five hundred years ago. Our architects rarely get such delicate lines as the Greeks did.

Every race and every age unconsciously write their character in the buildings which they erect, in the kind of furniture they put in them, and the kind of streets on which they place them. If a great American city were buried 2000 years under a mass of ashes, as Pompeii was, and was then excavated, it would be plainly seen what manner of people had lived in it. Our "sky-scrapers" and tunnels and mechanical conveniences would show how ingenious we were and how our laws permitted every man to build without regard to shutting off his neighbor's sunshine; they would show how we did business and how we cared chiefly for saving time and making money. Our city would show that we cared less for beauty than men did in former times. It would show that a few people were as rich as kings and lived in palaces, but that there were hundreds of thousands who were living in crowded tenements like ants in an anthill. Our school-buildings would show how we cared for education and our churches would indicate our manner of worship. All our good and bad qualities would be revealed by the things we had made, even if all the books about us had perished.

The Greek temples were rather long and low, and frequently had rows of beautiful pillars around the sides as well as at the front and rear. These pillars had grooves that ran from top to bottom and cast pleasant shadows. There were three kinds of pillars. The plainest ones that had no base and rested flat on the floor were called *Doric*. The slender pillars that rested on a base decorated with moldings and were finished at the top with a block of stone called a "capital," that looked like a cushion with its ends tucked under, were called *Ionic*. These beautiful Ionic pillars have been copied in many public buildings in our own country. The third kind of pillars was called *Corinthian*. These were also slender and, like the Ionic, had a base, but their capitals were carved to represent leaves. Extending across the top of the pillars was a band of stone which was divided lengthwise by little grooves into three parts. Above that was a row of carved blocks of stone.

In the triangular space under the gable were groups of figures. This space was called the "pediment." In the cornice were rows of little

blocks called "dentils," because they look like a row of teeth. Whenever we find an English word beginning with "d-e-n-t," like dentist or dentistry, or dentil, we may know that it has something to do with teeth. In many places on the Greek temples were bands of ornamentation called "tongue and egg" moldings, because they look like rows of eggs with long, sharp tongues between them. Greek moldings and capitals may be seen on thousands of buildings in America. The Greeks built beautiful gateways and market-places and open-air theaters, and sometimes beautiful tombs.

The Romans had a religion and climate and building-materials that were much like those of the Greeks, but they had a different government and were a less refined people. Their art was a good deal like the Greeks', but coarser and more mechanical. Their curves could be made with a compass. Their ornamentation was often heavy and overdone. They were, however, in advance of the Greeks in some things.



THE ITALIAN STYLE OF ARCHITECTURE.

They knew how to conquer all kinds of people and keep them all together and loyal to Rome.

In their buildings they used arches made of several stones held together by a middle stone called the "keystone," just as all the different

parts of the Roman world were held together by Rome. The use of the arch was new and important. It made it possible to erect much higher and stronger buildings than the Greeks had. Their arches were like a half-barrel. One of their most wonderful buildings was the Pantheon, at Rome, which had a broad, low dome held up without any pillars or support.

After the Roman world became Christianized we find that the most beautiful and important buildings were churches. In western Europe these were almost always built in the shape of a Latin cross. The long part was called a "nave" and the cross-piece was called a "transept." For many centuries these had the Roman arches over the doors and windows.

Gradually a new style, very different from the old Roman or classic style, became common. The churches had thick walls and small windows and square towers. The pillars and the carvings were totally unlike those familiar in the classic buildings of Greece and Rome.

Some of our most beautiful modern churches and libraries and small

Not far from the year 1200 A.D. another style of building began to be seen, which had a

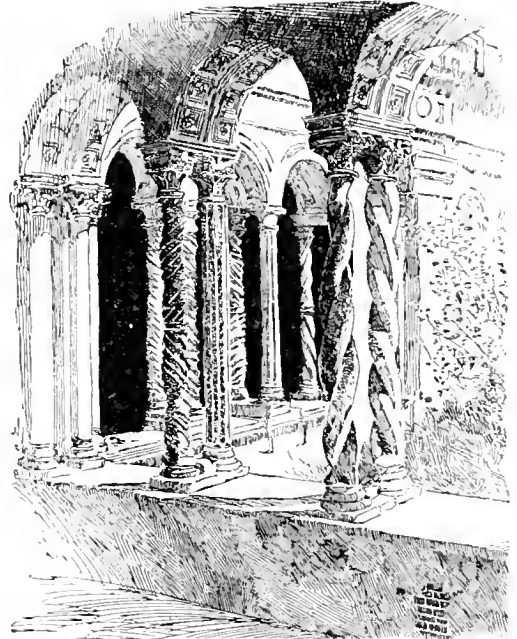

CLOISTER IN ST. PAUL'S, ROME.

pointed instead of round arch. This new style came to be called Gothic. At first its windows were called "lancet" windows, as they looked like the end of a lancet. After a time the lance-like end was filled in with beautiful patterns cut in stone, and was called "decorated."

Gothic buildings increased in number, and in three hundred years France, Germany, Spain, and England had not only hundreds of great churches, but city halls and private houses built in this style. The walls were thinner than the Romanesque walls and the windows were larger, as glass was becoming more common. The weight of the roof might have pushed the walls out if it had not

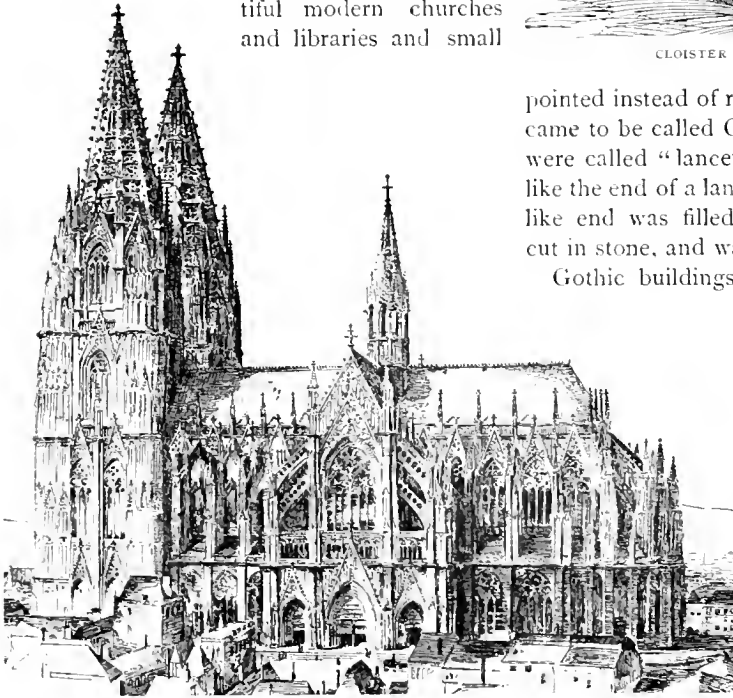

COLOGNE CATHEDRAL. A BEAUTIFUL EXAMPLE OF GOTHIC ARCHITECTURE

railway-stations are built somewhat in this old style, which is called Romanesque.

been for rows of stone braces, called "buttresses," that braced the walls up between the win-

dows. The Gothic churches often had spires rising from their towers. These were placed at the front of the church, and a smaller spire was often put just over the spot where the nave and transept crossed, as shown in the picture of Cologne Cathedral.

About the time Columbus discovered America another style was coming into common use. Men began, after so many centuries, to think again of the Greeks and Romans and to build splendid churches and showy palaces in a style that was largely borrowed from the Romans. They built the most magnificent domes the world ever saw. St. Peter's Church at Rome, St. Paul's in London, and later, our Capitol in Washington, were built in this style, which is called the Renaissance. Renaissance means new birth and stands for a new birth, or new interest, in old or classic ideas.

Most of the court-houses and city halls and state-houses in America are built of this style.

There are many different kinds of Gothic and Renaissance buildings as, of course, each century and each country had its own particular variety.

We put up buildings of Classic, Romanesque, Gothic, and Renaissance styles on the same street, suiting them to our own needs. Many of our buildings are of no particular style. There is no reason why we should invent a wholly new style. It is better for us to use the old forms wisely and develop them to suit modern needs.

It is often said that a little learning is a dangerous thing, for it makes people, who know only a little, conceited and critical. But, on the other hand, we must have a little learning before we can have much, and a little learning may make us ambitious, instead of conceited. It may open our eyes to a thousand new, interesting things in every-day life.

A little knowledge about architecture is more of a help, too, than a little knowledge about most other subjects. It is more important for the average American to learn to look at his city intelligently than it is to know what are the tributaries of the Amazon, or how many men were killed at the battle of Salamis, or a hundred other things, no more important, which he has spent much of his time in learning.



PAYING THE DOCTOR'S BILL.



WHAT UNCLE TOM DID.

BY ELIZABETH PRICE.

HE was the picture of innocence. His big brown eyes were meek and patient, his very long ears drooped resignedly, and he had a way of puckering his loose lips that gave him a most pathetic expression. The children hailed his advent into the family with shouts of joy and assurances of undying devotion, to all of which Uncle Tom responded with a subdued and polite nicker that completed his work of conquest on the spot.

"He is perfectly safe, Hester. The man who sold him declared I could trust him with the children at any and all times," said Mr. Thompson, trying to reassure his wife, who eyed with suspicion anything in mulish guise.

"Why did he want to sell him?" she demanded, still holding Baby Charlie out of the reach of those slim, unmoving hoofs.

"He belonged to a third-rate theatrical troupe," explained Mr. Thompson. "They've been playing 'Uncle Tom's Cabin' through the small towns in the State, and they claim this animal has many clever tricks at his command. Their funds gave out and they stranded here. The company has disbanded and they are selling their property possessions to raise money enough to get away on. I happened to see this little donkey, and when I thought what pleasure he would give the children I couldn't resist the temptation. So I bought him and named him without delay.

"He seems perfectly gentle — has probably had the spirit beaten out of him, poor brute. You wouldn't hurt a fly, would you, old fellow?"

and Mr. Thompson patted the shaggy, mouse-colored back. Once more the polite nicker came in response. The children shrieked with delight. "He answered, papa, he surely did. Oh, is n't he smart?" Uncle Tom parted his lips, as if smiling, and stood quite still until his new master lifted the baby on his back and led him toward the barn-yard, while Mrs. Thompson held her breath and waited for the catastrophe that didn't happen.

From that day Uncle Tom was—at least in his own estimation — the most important member of the Thompson family.

The trickeries of the creature were past belief, for besides those inbred in his nature, he had acquired many through the careful training of a clown, with whom he had been associated in a circus.

Fasten him as they would, leaving him to mourn in solitude while they played croquet or ball, in the midst of the game he would appear, smiling, frisking, getting directly in front of everybody and putting a stop to everything. If the children were given a between-meal treat Uncle Tom must share it; if they ran he ran, when they stopped he stopped. On one occasion when some workmen were repairing the furnace of the village church, he sauntered into one of the unused rooms in the basement, and frightened the poor old sexton by braying a vociferous "good morning," through the vine-clad easement-window.

Finally the novelty began to wear away. The children grew tired of a pet so unruly and

rather resented his attitude of self-satisfied independence.

And Mrs. Thompson rebelled. "George, for six months I've borne in silence with that unbearable animal," she said to her husband that evening. "I have come now to the place where patience ceases to be a virtue. My flower-beds are wrecks, the windows require daily attention, the children have no peace at their play, and visitors are frightened out of their senses by his unexpected appearance and ear-splitting bray. I can't be so annoyed any longer."

"Very well, I'll sell him to the first man, woman, or child who'll give me half what I paid for him. You can make yourself easy on that score, Hester," said Mr. Thompson.

"Very well, George. I'm quite willing."

The next day Mrs. Thompson and the children left home for a week's visit to grandfather. Mr. Thompson was to take his meals down town and sleep at home, and he boasted much of the blissful quiet and content he should enjoy. But after a day or two the content seemed to ooze away and the quiet began to pall upon him, so he invited his friend Fielding to spend a night with him. By way of extra hospitality, the host kindled the first fire of the season in the big base-burner that stood in the sitting-room, close by the bedroom door. The air out of doors was chilly and held a nip of frost, and the two men drew close to the fire, which, however, did not behave as well as it might, sullenly refusing to burn, and smoking badly now and then.

They sat late over their papers and cigars and

when, at last, they drowsily "turned in," neither one remembered to open the window. As for the stove, its many complicated dampers and drafts were as Egyptian puzzles to the man of the house, whose wife had always managed them; and the guest was a dweller in a down-



"ON ONE OCCASION HE SAUNTERED INTO ONE OF THE UNUSED ROOMS OF THE CHURCH BASEMENT."

town boarding-house, where hot air came through registers set in the walls. With no thought of danger these two grown-up innocents rolled into bed and soon slept the sleep of the just.

And while they still slept, in the early morn-

ing, the pet donkey, Tom, awoke in the stable and began to meditate. Not a child had been seen or heard of for two whole days. With a joyful nicker he broke loose from his stall, opened the stable-door, and kicked up his heels; then he set off at a lively pace for the house. Tap, tap, went the little feet on the board-walk, pausing at every window, as Uncle Tom rubbed his face against the glass and whimpered for the children. The shades were up and Uncle Tom could see two faces on the bed. Uncle Tom nickered and whimpered and whined, but there was no response and the children did not come.

Finally, tired of waiting, the little donkey passed to the window of the next bedroom, and, finding it closed, lowered his head slightly and deliberately pounded with his forehead on the window-pane. The first blow was without result, but the second shattered the pane. Delighted with the result thus far accomplished, the donkey laid back his ears and uttered a long-drawn bray that woke the echoes far and wide. The sudden rush of fresh air into the room dispelled the stupor that steeped Mr. Thompson's brain, and he opened his eyes. A deadly odor smote his dulled senses and a lethargy gripped his limbs. "Air—give me air!" he gasped, fighting feebly at the blankets. What could have happened—where were they all? Hester—the babies—Oh, if he could but reach the window—but the window was—so-o—fa-a-r. Then that awful noise recalled him to himself and he rose and staggered forward, only to fall to the floor trying with his last glimmer of consciousness to call his companion who lay as one already dead. At last the fresh air reached him, too, and he crawled over to the window of the communicating room.

Gathering his forces, Uncle Tom brayed a bray before which all his former efforts paled into insignificance. Again aroused by it, the limp figures in the room contrived to open another window. The rush of plenty of pure, bracing air gradually did its work, and Mr. Thompson managed to crawl to the door and call for help.

It was night before Mrs. Thompson could get to them, and the invalids had rallied con-

siderably, though still pitifully weak, and nervous enough to tremble as they told their tale. "Oh, my dear—my dear," exclaimed Hester, almost as pale as her husband, "it's no wonder you were suffocated without a breath of fresh air and not a damper in the right position! You know I told you particularly, George dear, that the base-burner was choked up everywhere and charged you to have the stove-man attend to it while I was away. It was unsafe to try to use it. I thought you knew."

"I—I believe you did say something about it," acknowledged the careless husband, meekly. "But I quite forgot, and anyhow I did n't suppose it made any special difference. It won't need cleaning now, Hester. We'll sell it for old iron to-morrow. But—I've decided not to sell Uncle Tom."

"Sell him! I rather think there is n't money enough to buy him—after—this!" The little woman choked in spite of her bravery as she remembered what her home-coming might have been. Then she resolutely choked back her tears, and made toast and tea, and shook out pillows and smoothed bedclothes, and drew the blinds and poked the fire—a cheery wood blaze in the dining-room—before which her two patients reclined in easy-chairs while regaining their strength.

It was quite late and dark as ink in the barn when somebody slipped past Billy's stall and Clover's, and laid loving arms about the little donkey's rough and shaggy neck; and somebody's voice stole into the silence with promises that never—*never*, should anybody have dear Uncle Tom except the family he had saved from a bereavement too terrible to be imagined.

"But for you my heart would be broken and my children would be orphaned! And to think I wanted you *sold!*"

Then the somebody slipped out again and laughed huskily at her own silliness as she hurried back toward the quiet house where life and happiness still reigned.

Mrs. Thompson looked up at the peaceful stars that twinkled cheerily back as she said fervently, "I thank God for all His blessings, and most of all, to-night, for Uncle Tom."



BOBBY IS GOING TO A PARTY.

A VISIT TO PLYMOUTH ROCK.

BY CORNELIA HICKMAN.

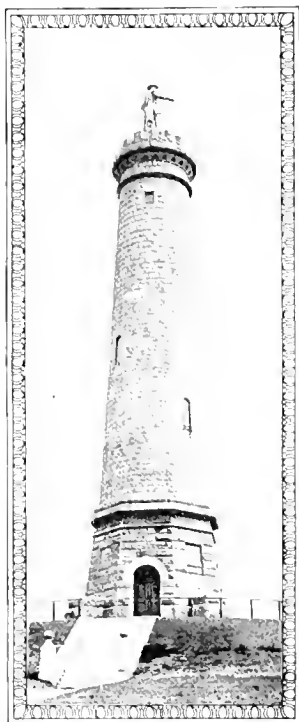

THE MILLS STANDISH MONUMENT AT DUXBURY, NEAR PLYMOUTH.

PLYMOUTH has been called the cradle of New England. It is on the coast, thirty-eight miles south of Boston, and is a thriving and prosperous New England town, with good schools and churches, and town hall, and shops of all kinds, and comfortable homes.

On the flat strip of land that runs for miles up and down the shore of the bay, the diminutive white houses of the fishermen are crowded close together. In the center of the same

flat land-strip, flanked on both sides by the fishermen's homes, is a large, open square forty yards from the water-front. Here stands Plymouth Rock, the first sight of which gives one a mental shock, for, no doubt, fancy has pictured an immense boulder rising grandly out of the sea; but, instead, the visitor sees only an oblong, irregularly shaped gray sandstone rock twelve feet in length and five feet in width at the widest point and two at the narrowest. Across one part runs a large crack which has been filled with cement, and which gives to Plymouth Rock a highly artificial appearance. The origin of this crack is a bit of unique history, and bears evidence to the early differences that at times divided the inhabitants into two factions.

For a long time there waged spirited and

bitter wrangling between the opposing parties, and it even settled down upon the much-cherished Plymouth Rock, which one party declared ought to be removed to a more worthy position in the town square, and the other wranglers protested it should not be moved an inch from its position, even though they had to guard it with their pikes and guns.

Finally, the stronger faction drew up their forces around Plymouth Rock, and in attempting to remove it up the hill it split asunder, which seemed a bad omen for those who had attempted such a thing, until an ardent Whig leader flourished his sword, and by an eloquent appeal to the other zealous Whigs convinced them that they should not swerve from their plan of carrying the rock to a place in the town square.

"The portion that first fell to the ground belongs to us," he cried; "and that we will transport with all care and diligence to its proper home."

Twenty yoke of oxen drew the Whig section of Plymouth Rock up the hill, amid the shouts of the throng that pushed forward around the liberty-pole which was to mark the new site. The ceremony of dedicating the rock in its new position was very impressive, and the people stood with bared heads, and in reverent tones chanted their high-pitched psalms in token of thanksgiving.

In the town square this part of Plymouth Rock remained for more than half a century, when a committee of the council resolved to move it back to its original position, and join it, as best they could, to the other half. Accordingly, in 1834, on the morning of the Fourth of July, the Plymouth Rock had been reunited in all seriousness to its long-estranged portion, and the union made complete by a mixture of cement and mortar.

To-day four granite columns support a canopy of granite that offers Plymouth Rock an indifferent protection against the rain and the sun, and

serves to keep back, in some measure, the thousands of sight-seers that come to Plymouth with only one object in view, namely, to press up around the iron bars, and to gaze through them

"Why, of course it is Plymouth Rock! What else could it be?" answers the man to whom the question is addressed; but, nevertheless, looking a trifle skeptical himself as he regards it. "It's not much to look at; but it's Plymouth Rock, just the same," he says in decisive tones.

From the wharf, with its fishing-boats and sail-boats ranged around its sides, one gets but an imperfect view of Plymouth Harbor and the sea beyond. Just climb the hill back of the fisherman's cot-



VIEW OVER PLYMOUTH
Rock

at the revered rock, on which they see the single inscription, cut in the middle of its face in long, plain figures: "1620."

The rock is surrounded by a high iron railing composed of alternate boat-hooks and harpoons, and inscribed with the illustrious names of the forty men who drew up the Pilgrims' compact on board the *Mayflower* that November day, as they sighted the coast that henceforth was to be their home.

"And so this is Plymouth Rock?" some one asks doubtfully. "Are you sure?"

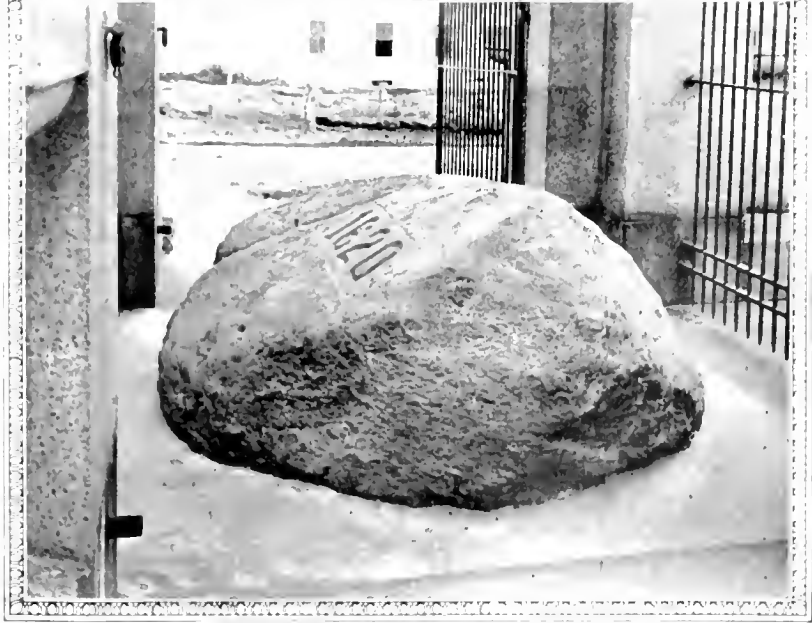

PLYMOUTH ROCK

tages, on which the main portion of the town is built, and pass on to the summit of "Burying Hill," and from this high point the eye can take in the long, narrow beach; the bald

crown of "Captain's Hill" on the left; the "Gurnet" lights upon their rocky promontory that runs out into the sea where the steamers come

the *Mayflower* who had perished from cold and hunger. It was there on Captain's Hill that Miles Standish built him a substantial log-house, in the vain hope that the Puritan Priscilla would one day become its mistress.



PLYMOUTH CEMETERY ON THE SITE OF THE WATCH-HOUSE

Far away to the north, beyond those distant hills yellow with fields of stubble, is Marshfield and the grave of Daniel Webster.

Viewed from the summit of Burying Hill, the scene is beautiful and restful, and one never to be forgotten.

Burying Hill might claim your attention for a week, with its ancient tombstones and their ingenu-

ous inscriptions, that are so quaintly and, oftentimes, humorously worded that they provoke a smile in spite of yourself. It is the old Plymouth burying-ground, and occupies one of the highest cliffs that overlook the bay.

A road leads down from Burying Hill through the old part of the town, along the narrow and crooked streets, with their square-roofed houses and queer-looking stores and warehouses, and rope-walks that run into byways, up and down hill, and finally emerge upon the ruinous old wharf with its rotting piles projecting far out into the harbor.

Duxbury Beach, scarcely twenty rods in width, stretches from the mainland for miles to the southward, interposing its narrow barrier of drifting sand between the stormy Atlantic and the quiet Plymouth Harbor lit up by the October sun.

Along Court street one goes, gazing at the houses on each side of the way, with scanty little front door-yards full of old-fashioned flower-beds; at the square turrets of the more pretentious dwellings; at the steeples and cupolas of the churches on the different hills; at the shops, big and small, with green blinds and dingy white fronts, until he comes to the town hall, on the right-hand side of the street. The hall is of rough granite, with a wooden veranda

"Saquish Head" guards the inlet, that grows wider and wider, and the lonely, wind-swept cliff is the homestead of a score of hardy fishermen whose cabins look as if they were about ready to topple into the sea.

On one high point rises the statue of John Alden; and, at the foot of Captain's Hill, you see the smoothed-over sward where were buried John Carver and his gentle wife, who could not survive her husband's loss, and the bones of fifty of the unfortunate passengers of

and go; and the placid blue waters of the bay. On the outer edge of the bay lies an island with an oval outline that slopes gradually down to the water in green curves, its round surface dotted here and there with clumps of cedars and stunted pines.

whose colonnades are Doric painted in imitation of granite. This building is "Pilgrims' Hall," and is seventy feet long and forty feet wide. The corner-stone was laid on the first of September, 1824, and the hall is divided into several rooms that are filled with interesting memorials and relics of the Pilgrims, and the *Mayflower*, and the early colonial days.

The principal apartment contains a large painting of the "Landing of the Pilgrims," by Henry Sargent. In the recesses of the windows are two old walnut chairs that came over in the *Mayflower*: the larger one belonged to Governor Carver, and the smaller one to William Brewster.

In a large glass case in this room there are many interesting relics, among which are the sword of Miles Standish; the clumsy-looking gun whose bullet killed the brave King Philip; a small iron pot and a dish that were brought over in the *Mayflower*; John Alden's Bible; some wearing apparel that was the property of Alice Bradford; watches, swords, seal-rings, flint-locks, stocks, and gauntlets that once belonged to prominent citizens of the colony.

In a frame on the wall in one room is a faded sampler worked by the dainty fingers of Lorea Standish. There is a deed signed by Miles Standish, and another bearing the signature of John Alden.

Here is a bond of Peregrine White, the first native Yankee, as he was the first child born in New England.

In an adjoining room is a portion of the library belonging to the Pilgrim Society. Here are the Indian Bible translated by John Eliot, "the Apostle to the Indians," and some inter-

esting books and manuscripts that were prized by the governors of Plymouth, for books were rare in those days. In the basement one sees some very thick boards, that might have formed a part of the hull of a small vessel, raised upon a platform. This is said to be a fragment of the *Mayflower*.

In this big underground room the Pilgrim Society of Plymouth has given many a dinner in commemoration of "Forefathers' Day," as December the twenty-second is styled.

Passing on from Pilgrims' Hall down the main street, one sees that the houses are generally built close upon the sidewalk, and that the lower stories are used as shops and stores.

Levden Street is the oldest street in Plymouth,

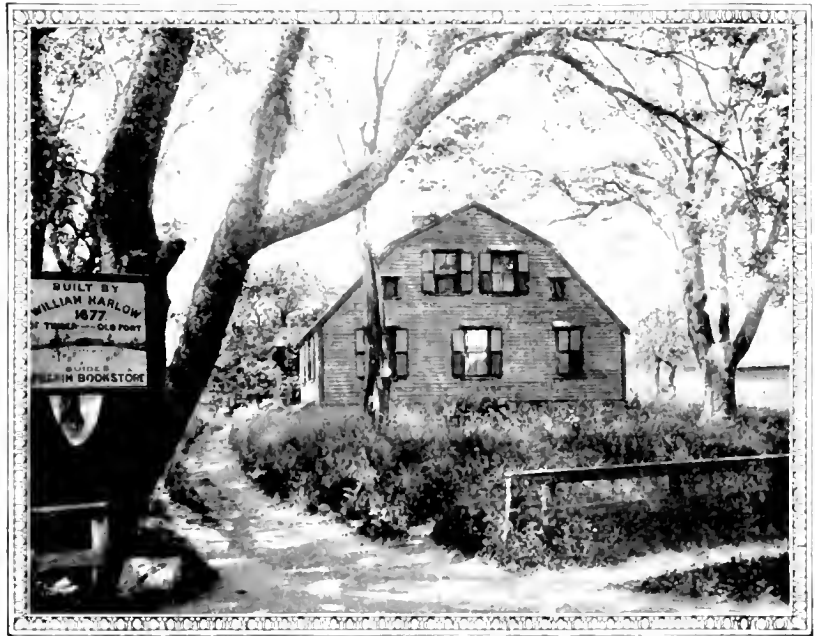

THE HARLOW HOUSE, BUILT FROM TIMBER FROM THE OLD FORT.

Lots were laid out upon it within a week after the landing, and wooden gates were built at the ends of the street, and a stockade raised against a sudden attack from the Indians.

On Plymouth Hill stands the imposing statue to the Pilgrims. Its base is granite and supports a seated figure at each of the four corners, with eyes searching the surrounding country, while a woman's figure crowns the top. On the pedestal is inscribed the name of every man, woman, and child that came over in the *Mayflower*.

HOW TO STUDY PICTURES.

BY CHARLES H. CAFFIN.

A series of articles for the older girls and boys who read "St. Nicholas."

ELEVENTH PAPER.

COMPARING FORTUNY WITH VON PILOTY.



"THE SPANISH MARRIAGE" BY FORTUNY (FROM A PHOTOGRAPH BY LAURENT & CO.)

MARIANO FORTUNY (BORN 1838, DIED 1874);
KARL THEODOR VON PILOTY (BORN
1826, DIED 1886).

IN Fortuny's picture "The Spanish Marriage" there is much beautiful detail to gladden the eye; in the canvas by Piloty, with its long title, a great deal to stimulate our interest in historical incidents. We already feel a curiosity to become acquainted with this particular one. We reach for a history to discover who these people are, and how they happen to find themselves in the circumstances represented; and, having read the story (which will be retold later in this article), we shall proceed to search the picture to identify the persons and see how the incident has been portrayed. All of which has, strictly

speaking, nothing to do with the appreciation of the painting, as a painting. On the other hand, to appreciate the "Spanish Marriage" we need no help from outside; the incident depicted explains itself. An elderly beau and young belle have been united in marriage at one of the altars in the church, and are now with bridesmaids and guests assembled in the sacristy to sign the register. For the rest, we are free to enjoy without any interruption the brilliant groups of figures and the exquisite delicacy of the great screen and the other details of the sacristy.

Again, let us contrast the two pictures from the point of view of composition. In Fortuny's the figures are sprinkled like gay flowers across the picture and surrounded by open

spaces; the impression produced being one of spaciousness and dignity, united to elegant sprightliness. In that of *Piloty*, however, the figures, following the line of a letter S, occupy almost all the composition. Except for the little piece of ground in front, and the view beyond the arch, there are no quiet spaces in the picture. Moreover, while *Fortuny* has massed his shade beyond the screen, giving a depth and mystery to the distance, *Piloty* has scattered his

in comparison with which *Piloty's* seems artificial and confused and broken up. Perhaps this is intentional; perhaps the artist sought in this way to create a suggestion of stupendous impressiveness, corresponding to the strange, tumultuous spectacle that the actual incident must have presented. If so, in order to attain his object he has sacrificed the unity of his picture, which as it now stands might almost be called a combination of several smaller pictures



"THUSNELDA AT THE TRIUMPH OF GERMANICUS," BY VON PÜCHEL. (FROM A PHOTOGRAPH BY FAYET.)

over the whole picture. It might be difficult to find a natural cause for the shadows striking where they do; but the artist's intention is clear enough — namely, to bring out strongly the center group composed of *Thusnelda* and her child and handmaids, and give a somewhat slighter prominence to the Emperor *Tiberius*. Below the latter are the lighted figures of the old priest and the German soldier to whom he is bound, which lead up, so to speak, to the central mass of light.

Now, while the composition of each picture is arranged with deliberate planning, *Fortuny's* is so excellent that the scene appears real and impresses us at once as a single harmonious whole,

— the group with the bear in the front; the group of women; the emperor's group; that of the senators at the back welcoming *Germanicus*, the conqueror — a set of separate incidents ingeniously linked together.

And now examine more closely the individual figures. Those in the "*Spanish Marriage*," how they brim with life and character! Note the attitude of the priest, as he rises from his seat and leans over the table while the bridegroom signs his name. What an elderly top the bridegroom is, arrayed in his rich costume! The bride is in a white gown trimmed with flowered lace and has a wreath of orange-blossoms in her luxuriant black hair. She is toying with a

fan, enjoying its pretty decorations, while she listens to the remark of a girl friend, who leans forward with a most delightful gesture of dainty grace. How cleverly the artist has suggested in the conduct of all the people present that this union of age and youth is not an affair of the heart — not a real "love-match" as we say! Observe particularly the indifference which the couple sitting on the right display to what is going on; while an old man has removed to a far corner, and sits with his hat on his head, as if in contempt of the whole proceeding.

But in Piloty's picture, too, there is no lack of gestures and poses; every figure enacts some separate part in the drama; each is drawn with correctness and power. Yet, I suspect, the sum total of the impression that we receive is not so much of life and reality as of a great spectacle, such as one may occasionally see on the stage of a theater. The tableau has been arranged by an ingenious stage-manager, who has packed it with stirring situations and piled effect upon effect. The scene-painter and costumer having done their share, he has drilled the crowd of supernumeraries until every one of them knows what he is expected to do and does it with all his might, as if the success of the whole depended upon his individual effort. The result is overpowering and magnificent, but unreal, stagy. It is too ambitious and self-important. It reminds us of a high-sounding remark by a certain German historian who lived at the same time with Piloty. "We stand," he said, "on a summit overlooking the whole past. To bury one's self in the past, to get at the most essential meaning of its life, to renew what has vanished by art—such is the vivifying work of our time."

But is this picture vivifying? It may succeed in awakening knowledge of the past, but does it renew its life? Certainly it is interesting as an illustration of that page of history which relates how Thusnelda, the wife of Harminius, a German prince, was betrayed by her own father, Segestes, into the hands of the Romans, in order to curry favor with Germanicus, the Roman general. But Germanicus' success had aroused the jealousy of Tiberius. Roman emperors lived in constant fear of being dethroned by a victorious general, so Germanicus was recalled to Rome and allowed a "triumph," which

Thusnelda, the German queen, is compelled to adorn by walking in the procession as a captive, with her little son, and her handmaids. Her humiliation the miserable Segestes, her own father, who had betrayed her into the Romans' hands, is forced to witness. In the latter's bowed head may well be brooding a dread of Germanicus, and of vengeance against Rome, if these magnificent barbarians should ever discover their own strength and Rome's growing weakness.

After all, how much more effectively a writer could represent this scene! He would make you realize not only the outward appearance of the spectacle, but also the inward emotions that are stirring in the individual actors. He would fathom not only the thoughts in the brain of Tiberius, but those in the woman who proudly marches past him; those of the Roman ladies; of that priest and the German warrior to whom he is bound; of that woman on the left who raises her arm in anger at the captive queen; of the people applauding the victorious general; and of what lies concealed in the mind of the conqueror, calmly uplifted against the lighted distance.

The fact is that a picture of this sort, by attempting to represent so much, passes beyond the point at which it can give a single great, lasting impression; steps outside of its own special mission as a record of what the eye can grasp without assistance; and challenges rivalry with literature on the latter's own ground, and, therefore, naturally is worsted. Yes, a clever writer could represent this scene to our imagination and move our emotions much more vividly than this picture does.

Like most of the so-called historical painters, Piloty has selected a subject that will yield opportunity for striking contrasts and for display of his skill in drawing and archaeological learning; and then, by crowding the large canvas with learned details, cleverly represented, seeks to impose upon the spectator an impression of something grander than the ordinary—heroic. For, as a rule, the "historical" painter thinks that the representation of the life of his own day is vulgar. He has learned to draw the human form and draperies, in art schools, and then rummages amid the dust of antiquity to find

subjects that will demonstrate his skill. Turn to Piloty's picture and note the old priest in the foreground. The upper part of the body is represented nude, and the drapery below is so arranged that the old man could not possibly walk. What could be more obviously dragged in for effect?

Most of these painters are able draughtsmen, although their figures are generally coldly correct, or stilted and bombastic; but few of them are good painters. Piloty, however, was an exception. He received his education at the Munich Academy, under men who were inclined to boast that they were not painters and to look down on the "colorers," asserting that "form is everything." But after he had visited Venice, Antwerp, and Paris, he came back a skilful painter, who could render correctly the color-appearance of any object he represented. Munich was eager for something new, in art, and he obtained sudden and great popularity. In 1852 he was appointed professor at the Academy, and, through the great number of pupils who flocked to him and the influence that he exerted over Germany, he really revived in that country the art of painting.

For the Germans, like the English, are disposed to prefer a picture which tells a story. Piloty, as we have seen, chose historical subjects; but a very large part of modern German painting is occupied with the little pictures of social or peasant life, in which the personages, generally set in an interior, are enacting some pretty sentimental scene. They are, for the most part, cleverly painted, but usually, like Piloty's pictures, without any suggestion of inspiration, of real atmosphere or of remarkable skill. It is in this respect that Piloty is not a "painter" compared with Fortuny.

The latter, after receiving the usual academical training at the School of Fine Arts in Barcelona, won the prize which enabled him to go to Rome to pursue his art studies. But while he was studying the old masters in that famous city, war broke out between Spain and Morocco. Fortuny, then twenty-three years

old, received a commission from the town council of Barcelona to proceed to Africa and paint the exploits of the army. This experience of a few months changed the whole current of his life. The brilliance of the Moroccan sunshine, the glowing colors of the scenery, the richness of the costumes and the splendor of decorated trappings and weapons, the glittering movement of the life of the people — all these things fascinated him and drew all his imagination into the direction of light and color. Other painters before him had been attracted by the charms of the south, but none up to that time had so absorbed the inspiration of the color-splendors and the charm of the Oriental life.

At first he introduced these qualities into a series of Moroccan subjects; then passed on to pictures like our present one. They represent interiors decorated profusely in the style of Louis XV, known as rococo,* because the ornamentation included imitation of rockwork, shells, foliage, and intricacies of scroll-work. These countless details, and the gay silk and lace and velvet costumes of the period he learned to portray most skilfully.

His pictures sparkle like jewels and are as brilliant as a kaleidoscope. When he went to Paris he made a great sensation and became attached to the circle of which Meissonier was the leader. The latter's pictures are like his in the minuteness of their craftsmanship, but do not show the same exquisite color-sense. In fact, Fortuny himself set the fashion for a class of pictures filled with silks and satins, bric-à-brac and elegant trifling, distinguished by deftness of hand, but possessing no higher aim than to make a charming bouquet of color with glancing caprices of sunshine. Because they were painted with remarkable cleverness they attracted extravagant admiration; but now that clever painting has become general, their reputation has declined to that level which shallowness of motive always reaches.

In art as in life, a man must have a great and noble aim, to accomplish results that will be lasting.

* A French word made in imitation of the French word *rocaille*, rockwork, from *roche*; Middle Latin *roca*, a rock.

THE OWL AND THE PUSSY-CAT.

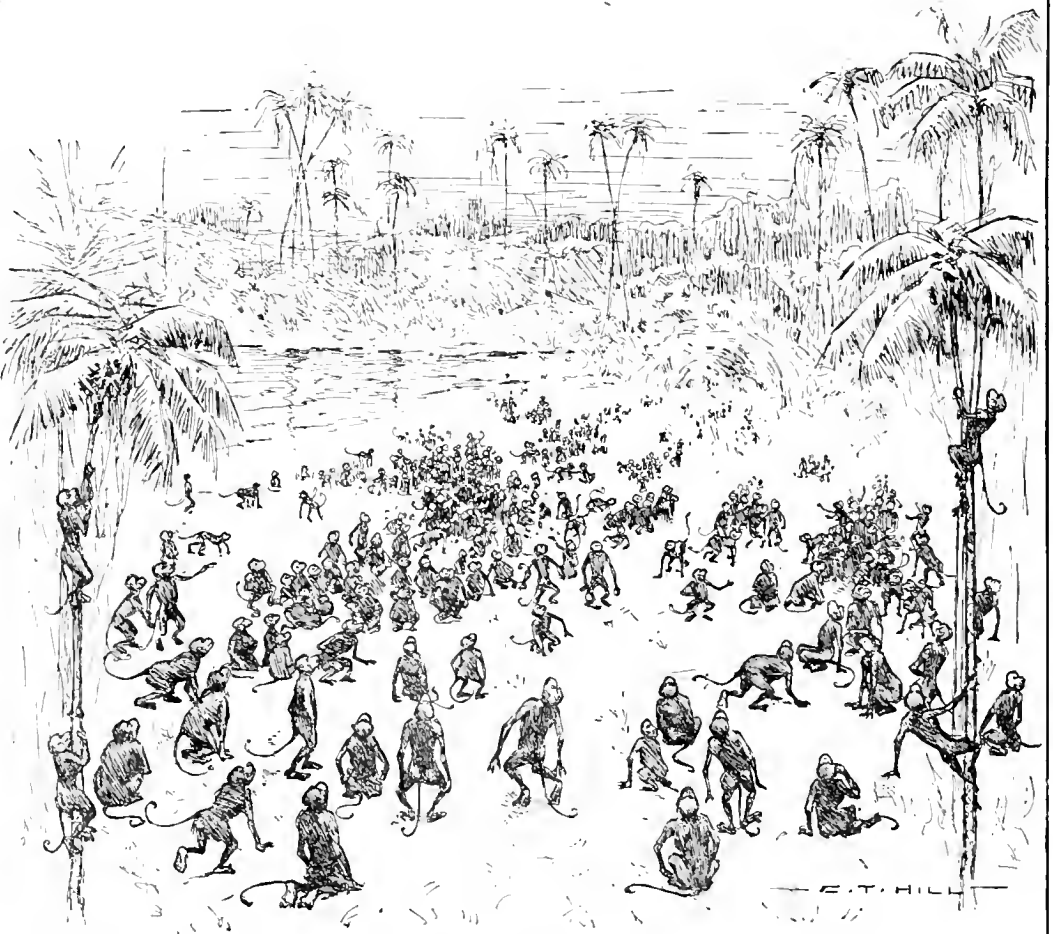
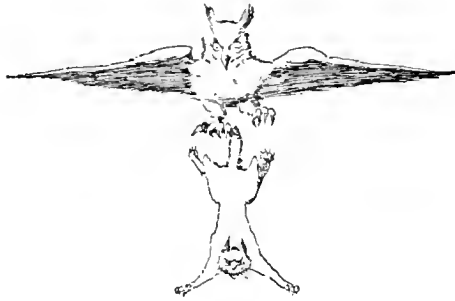

THE OWL AND THE PUSSY-CAT FLEW O'ER THE SEA,
TO BE GONE FOR A MONTH OR SO.
BUT AT LAST THEY CAME DOWN IN A BIG MONKEY TOWN
IN THE HEART OF BORNEO.

THE TIN-PEDDLER.

By LUCY FICH PERKINS.



Out, the tin-peddler's life is happy and gay!
He 's up in the morning before it is day.
He sees the red dawn come up in the sky,
Birds sing in the hedges as he goes by;
The roosters are crowing their morning alarms,
The smoke rises high from the chimneys of farms;

He sees the dew sparkling on corn in the shock,
And the shepherd go forth to care for his flock.
When the world is awaking he rides on the road,
Sitting atop of his shining load.

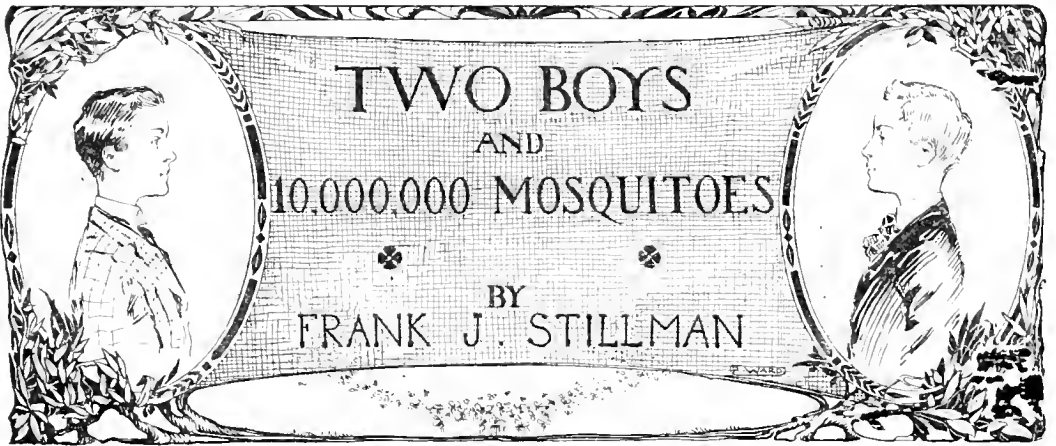

THAT Zeb and Darwin were good fellows was admitted without debate, but while the "nine" buckled into hard practice every afternoon in early summer, and the first team hammered and butted the scrub eleven from one end of the gridiron to the other in the autumn, Zeb and Darwin "tinkered with some contrivance" or "studied a mess of dope in the laboratory."

Zeb Ferren was the son of a retired farmer. Darwin Russell's father published a weekly newspaper in Low Lake, a county-seat town of three thousand inhabitants. Notwithstanding the oft-repeated statement of his father that he must some day "run the farm," Zeb had steadfastly declared that he was going to be a doctor. When Mr. Ferren rented the farm and moved to Low Lake, Zeb, then sixteen, spotted the town library, got acquainted with the librarian, and had buried himself in a work on anatomy even before the parlor carpet had been laid in his new home.

Darwin Russell's mother declared time and again that he would certainly kill himself, or blow his hands off. Before he was fifteen Darwin had rigged a water-wheel, attached to the hydrant, to a jig-saw; connected the house and printing-office by telephone; built a motor-fan that drew its power from home-made gravity batteries down cellar, and scorched his eyebrows manufacturing "gas" from sulphuric acid and zinc. But when the "air-springs" on the cylinder-press at the printing-office balked, and the grease-besmeared, perspiring foreman crawled out from under the "bed" and raved

and spoke about a "junk pile," Darwin made a few passes with a monkey-wrench and the old "cylinder" began at once to reel off its 1200 impressions without a jar.

Zeb and Darwin were class-mates in the third year, and their acquaintance quickly grew into very close companionship. Darwin, who had hitherto followed, all alone, his bent for chemistry, electricity, and mechanics, found great joy and inspiration in the fellowship of a boy after his own heart's desire, and Zeb, coming for the first time within the precincts of a real "laboratory," fairly reveled in the opportunities afforded.

The spring rains, the year after Mr. Ferren moved to town, broke all previous records in that part of the country. For weeks farmers were unable to do a stroke of work in the fields, and it was June when settled weather came and crops were finally in. Low, marshy places had developed into shallow lakes, and puddles stood about everywhere. Mosquitoes began to appear. They had never before been seen in such swarms as swept over the town. And such mosquitoes! Big, ferocious mosquitoes that followed their victims like wolves and left upon them marks that stung for hours.

Within a week the people of Low Lake were up in arms. Finally the town council grappled with the question. The National Mosquito Extermination Society was appealed to for aid, and advised the use of coal-oil upon all standing waters in town and vicinity. The secretary, in replying to the council's letter, went into the matter with some detail. He wrote:

The female mosquito deposits from 150 to 400 eggs upon the water; in five days these eggs become larvae or "wrigglers," and about five days later emerge from the water full-fledged mosquitoes. During this second period the wriggler must frequently come to the surface to breathe. Oil upon the water prevents this, and the insect perishes in a few moments. The life of the mosquito is comparatively brief, and if the wrigglers are prevented from maturing the insects soon disappear.

Great activity followed the receipt of these suggestions. A car-load of coal-oil was ordered by telegraph. Town and adjacent country were divided into districts, and half the men and boys in town as volunteer field-workers, clad in overalls and armed with big sprinklers, sought the watery haunts of the pestiferous insect and poured oil upon the trouble-breeding waters in the marshes and ponds.

But weeks dragged along into a month, bringing no appreciable relief, and there were signs of discouragement. Enough oil to kill all the wrigglers in the State had been used, yet the ranks of the mosquitoes were promptly recruited from somewhere.

In response to another letter to the National Mosquito Extermination Society, the following telegram was received:

Experienced New Jersey mosquito expert will arrive Low Lake Thursday; prepare to proceed under his direction.

The expert came and declared the work to be lacking in thoroughness. "Thoroughness is the price of success," said he; "unless every pond, puddle, or receptacle—every unused well or cistern, every tin can, broken bottle, or hoof-print of cattle, every spot capable of holding exposed water is drained, or the surface covered with oil, you will fail to obtain satisfactory results. On the other hand, mosquitoes cannot breed without standing water and if you are thorough and persistent, deliverance will come."

A town council meeting was held and, after much debate, it was decided that lasting relief could be found only in the costly plan of draining the marshes. The season was too far advanced, so the plans were laid for the following spring.

During the remainder of the summer Zeb and Darwin wrought valiantly with the other oil-sprinklers. Several times Darwin had expressed the belief that a method of exterminating the hungry hordes could be devised.

"I've got it," he exclaimed, meeting Zeb one morning, late in September, on the way to school.

"Got what?" said Zeb, in alarm.

"You know, about the boll weevil and the devastation it has wrought in the cotton fields of the South," said Darwin, excitedly. "Well, the Secretary of Agriculture has just imported from Guatemala a species of red ant that, when introduced into the cotton-fields, makes short work of the weevil—cleans 'em out as a ferret does rats in a barn. There is our cue: we will import some sort of an insect that will destroy the mosquitoes. I read the other day that Persia, which has a climate similar to ours, has no mosquitoes. Let's write to some one there."

The next day a letter was despatched to the United States Minister at Teheran, Persia. It read as follows:

DEAR MR. MINISTER: During the summer just past our town has been afflicted with a plague of mosquitoes, due to excessive rains and near-by marshes. We have fought them with coal-oil and other weapons without success. We are informed that mosquitoes are unknown in certain parts of Persia, and we thought this might be due to their having been exterminated or driven away by some other insect. If this is the case and it is not asking too much, we would like to have you send us by mail some of the insects, so that we may turn them loose on our mosquitoes. We are boys in the third year of the high school. This is our own scheme and a secret. If you could know how our people have suffered all summer, you would, we are sure, go to some trouble, if need be, to help us. Hoping to hear from you with the mosquito-destroying insects, if such insects there be, and assuring you of our appreciation, we are,

Yours with great respect,

DARWIN RUSSELL,

ZEB FERRIN.

P.S. We inclose newspaper-clippings telling what a fearful time we have had.

United States Minister,
Legation United States of America,
Teheran, Persia.

Zeb and Darwin mailed their letter with full knowledge that several weeks must elapse before a reply could be received. In the meantime a laboratory was fitted up in a spare, vacant room in Darwin's home, and here it was proposed to carry on the experiments.

They procured a jar of pond water containing wrigglers, and placed it in a woven-wire screen. Within a week the wrigglers had dis-

appeared and hundreds of adult mosquitoes swarmed within the cage.

In the course of nearly two months, they received a letter from the secretary of the Persian legation saying that, so far as he knew, there were mosquitoes everywhere in Persia.

For a few moments neither boy spoke; then Zeb said with bitterness, "It 's just as I was afraid. Darwin, we 're on the wrong track."

"Well," groaned Darwin, "we have several hundred thousand game mosquitoes on hand at bargain prices; I suppose we might as well take the big cage out and make a bonfire of them."

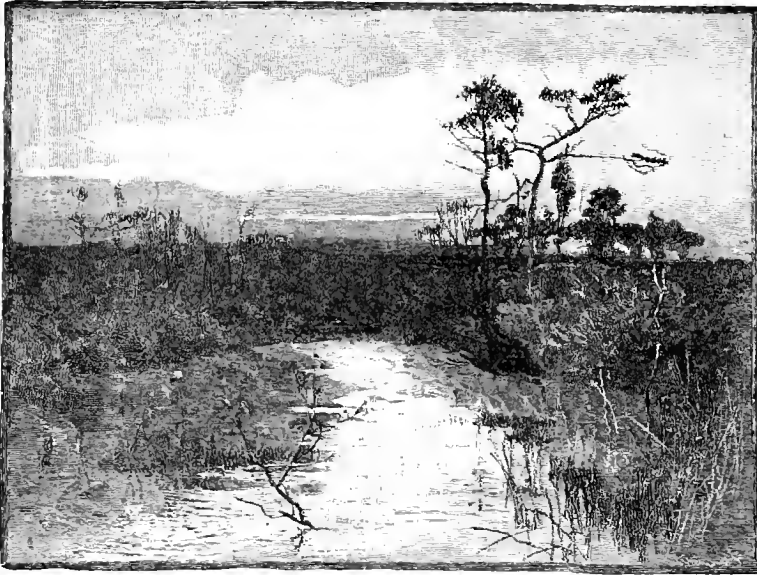

"THE LOW, MARSHY PLACES HAD DEVELOPED INTO SHALLOW LAKES."

"No, we may need them," said Zeb. "I have another scheme. I propose that we tackle the insect from another quarter; that we poison him, smother the whole army at one stroke. My idea is to discover a combination of chemicals that will produce a gas that will prove fatal to mosquitoes without injuring the delicate cells of the human lungs. What we want is a gas heavier than air, so that it may be diffused in the upper air and descend."

"That 's a grand scheme on paper, but is it possible to discover or produce such a gas?" inquired Darwin.

"It 's certainly worth an earnest, persistent effort," responded the farmer's son, with animation. "Remember how Mme. Curie, the French-

woman, toiled in her meager laboratory for ten years, working away at apparently worthless pitch-blende; trying endless analyses and combinations, and how in the end she gave to the world that wonderful new element, radium, and jarred the very foundations of chemistry itself. The mosquito, undoubtedly, possesses a weak spot; we have our own and the high-school laboratory at hand and a plentiful supply of insects; we may yet discover the vulnerable point."

"First, let us get down to bed-rock," continued Zeb, "and make lists of all known gases; then get away from the beaten path and dig up some new combination of elements. That is our only hope. If no known gas is fatal to mosquitoes and not injurious to man, then we must produce an entirely new gas, and it must descend instead of rise in the air."

Then, day after day and week after week, the youthful chemists worked and experimented. Gases without number were produced; some mild and odorless; occasionally a mixture that drove them precipitously from the laboratory. Yet the mosquitoes thrived and multiplied, apparently unconscious that science sought their undoing.

"What 's that?" inquired Darwin, as Zeb entered the laboratory one afternoon in the late spring and drew a baking-powder can from his pocket.

"That 's what I would like to know," said Zeb, exhibiting a powdery, yellowish substance. "The men drilling the new well for the town struck a five-foot vein of it at a depth of 320 feet; I don't suppose it possesses chemical properties of any value to us, although it does have an odd odor and is slightly acid."

A sample of the material was submitted to

Professor Hanson, the chemistry teacher, who declared he had never seen anything like it before. Professor Hanson was deeply interested in the new substance and mailed a sample to Dr. Tanning, of the government Bureau of Chemistry. As a precautionary measure, Zeb carried a pailful of the yellow mineral home and put it in a dark corner in the cellar.

In about a week Professor Hanson received a letter from Dr. Tanning asking for further information concerning the sample mineral, and requesting that a larger quantity be sent by express. The yellow mineral was unknown at the Department. In honor of the discoverer, Professor Hanson named the substance "ferrenite."

In the meantime Darwin and Zeb had made numerous unsuccessful experiments with it. When dry, unslaked, and saturated with coal-oil it burned with a violet flame and diffused a pungent odor, but the mosquitoes appeared unaffected by it.

But Darwin says he will never forget the staggering sight he beheld one morning when he entered the laboratory. The bottom of the big cage lay an inch deep with dead mosquitoes; not a live insect could be seen.

At the close of school the boys hurried back to the laboratory. Suddenly Zeb walked to the side of the room where innumerable bottles stood upon shelves; seemed to be scrutinizing something closely; then burst out with: "Hurrah, we've got it; see here, the mosquitoes were simply smothered, asphyxiated; whoopee!"

What Darwin saw was an overturned bottle of sulphate of zinc solution, carelessly placed on the shelf, a small portion of the contents of which had spilled into a flat tin box containing a bit of the unknown yellow mineral. There were unmistakable evidences that chemical action had taken place.

"We can settle that question very quickly; let's see what the effect is: here, pour some sulphate on this fresh stuff," shouted Darwin, in a delirium of excitement; "that will prove if you are correct."

That the two substances produced a gas was speedily proven. When the sulphate of zinc fell upon the yellow mineral, a violent effervescing occurred, which caused an odor unlike anything the young chemists had ever before

known. Furthermore, it was found that the gas fell to the floor. Darwin and Zeb were in a state bordering on hysterics over their accidental discovery and the circumstantial evidence so strongly pointing toward success, yet just a shadow of doubt tempered their joy.

"We've got our heavy gas, all right; now we'll try it—great guns! Zeb, we have n't a solitary mosquito to experiment on, and I don't suppose there is one this side of Florida!"

Again they were forced to raise their own mosquitoes, which they succeeded in doing within the next three weeks.

After they had transferred enough insects to the "mosquito cage," a small bit of ferrenite was dropped into the zinc solution, sizzling and bubbling, and the boys stooped to note the effect on the victims in the cage on the floor. Suddenly the mosquitoes in the upper section fell to the bottom, and as the gas wave quickly descended, all perished.

"What does this mean?" cried Mrs. Russell, hurrying upstairs and throwing open the laboratory door. "Is the house on fire, or are you both killed or maimed. Judging by the sounds, a band of Indians has taken possession of the house."

The boys apologized, said they were all right and happy, and Mrs. Russell, still with an anxious face, departed. Wild with delight Darwin and Zeb were tempted to herald their great discovery, but finally concluded to wait. A gas fatal to mosquitoes had been discovered, that was certain; the practical value of the discovery and its effect in open air remained to be proved.

Later on, an experiment under conditions that would enable them to decide more accurately what might be expected of the gas out of doors was made in the mammoth old roller-skating rink. Two small cages of mosquitoes were placed on the floor at either end of the building. Perched on one of the cross-beams supporting the roof, Darwin immersed a small piece of ferrenite in the sulphate of zinc solution. In less than a minute the insects were dead.

Professor Hanson was incredulous when informed of the discovery,—having first given a pledge of silence,—and not until he had witnessed a demonstration in the rink would he

believe. Even then he shook his head and declared the boys were playing a trick on him. The two fathers were let into the secret and scouted the theory, and only believed it, if indeed they did believe, when they saw live mosquitoes fall dead.

The latter part of May was at hand, and the sub-committee of the town council, assisted by a drainage engineer, had advertised for bids on the big work of cutting through the hills and draining the marshes. The cost was variously estimated at from \$15,000 to \$20,000. Zeb and Darwin determined to stay proceedings before the contract had been let and it was too late. Editor Russell was consulted and advised the boys to go before the council and make a statement.

"But we can't present the matter as it should be presented," protested Darwin.

"Yes, you can; you are the only ones able to demonstrate and explain your theory," rejoined his father. "Go ahead; make an appointment for a hearing, tell the council what you can do, and offer to prove your claims. They'll hear you. See the mayor to-day and ask for half an hour to-morrow night."

Mayor Davis's consent for a hearing was readily obtained, and the boys were promptly on hand at the Tuesday evening meeting. Darwin declared he could not make a speech, and Zeb was forced to proceed. In a straightforward, quiet way the young man reviewed the experiments, omitting minor details, concluding with the statement that a gas, fatal to mosquitoes, produced by inexpensive chemicals, harmless to man, had been discovered. Generated in the upper air the gas settled, destroying mosquitoes and their larvæ; practical experiments had proved this; it would be a pleasure to demonstrate the operation of the gas to the honorable council at its convenience.

Naturally the proposition amazed and staggered the town officials, yet the very audacity of the scheme and the high standing and reputation of the young men, compelled earnest consideration. Of course the council would be glad to witness a demonstration, and would respect the request that secrecy be maintained.

The experiment was in every way similar to those previously made in the laboratory, and a

majority of the "city fathers" at its conclusion said they were satisfied the gas would destroy mosquitoes. The effect of the gas in open air, with wind, rain, and varying climatic conditions, however, remained to be proved. By vote of five to one it was decided to postpone awarding the contract for the marsh drainage, pending conclusive proof of the results of the gas.

It was, of course, no longer possible to keep the discovery secret, and before night it was upon every tongue. Opinions varied as to the value of the scheme. One newspaper ridiculed the idea. Mayor Davis, however, stoutly declared his faith in the new theory.

With the rapid increase of mosquitoes a good deal of uneasiness as to the outcome prevailed, even among those who had great faith in the young chemists, and Zeb and Darwin began to feel the strain of heavy responsibility. The skeptical ones boldly declared the whole business to be child's play, and severely censured the city authorities for allowing themselves to be led away from a plan that insured lasting relief by a couple of dabsters in science — well-meaning but imaginative boys with a veritable will-o'-the-wisp scheme.

Announcement had been made that the demonstration would occur Saturday evening, June 28, at 7:30. News of the wonderful discovery of an insect-destroying gas by two high-school boys had been heralded throughout the country, and such interest was everywhere aroused over the prospective experiment and its far-reaching effects, that correspondents representing the leading daily papers, and eminent scientific men began to arrive Friday, and by Saturday noon rooms in Low Lake's two hotels were at a premium. The townspeople were keyed to the highest pitch of excitement.

Zeb and Darwin had employed their time in careful preparation for the event that should make them famous or cover them with the blight of permanent ridicule. At their suggestion four spliced poles seventy feet long and fitted with tackle, were erected near the four corners of town. From these heights and from the flag-pole in the courtyard square, at the center of the town, the gas would be generated.

The evening was peaceful and balmy; in fact, rather too "close," if anything, for per-

sonal comfort. At seven o'clock the last narrow rim of the sun disappeared behind the low hills. It seemed that almost the entire population of the town, big and little, had business in the vicinity of one of the five centers of interest, and one might have fancied it to be Fourth of July night. Everybody fought mosquitoes, which, evidently scenting abundant prey, were present in tremendous numbers.

On the stroke of the half-hour bell, Zeb and Darwin, assisted by their fathers and Professor Hanson, stationed at the foot of their respective poles, hauled seventy feet in the air five granite-ware pails of sulphate of zinc solution, into which had been placed that instant several pounds of the yellow mineral.

After a seeming age of breathless waiting—eighty-five seconds to be exact—during which the dead silence was unbroken save for the swish of a hat or the slap of a hand when the mosquitoes became particularly vicious, those nearest the poles detected a slight odor; strange though not unpleasant, followed almost instantly by the cessation of that familiar humming. A moment before and the air had seemed alive with ferocious mosquitoes; now they had disappeared. As if by magic the intolerable plague had been abated; deliverance had come!

From the five sections of town, almost simultaneously rose the sound of cheers, augmented by other shouts, as the descending wave reached and destroyed the insects, until the town rang with a mighty and prolonged roar of voices.

In the exuberance of his joy, Dick Tyler, the novelty-store man, dragged out the remnant of his last year's Fourth of July stock of fireworks, and soon the sky was ablaze with screeching rockets, bursting mines, and hissing candles. Attracted by the display, the people from all quarters assembled in the courtyard and high carnival reigned until midnight. Low Lake went wild over an evening out-of-doors without a battle with hungry mosquitoes.

The busiest man in town that night was

Harry Roberts, operator at the telegraph office. By ten o'clock he had more "copy" on his desk than had been sent out of Low Lake in a year, with a dozen newspaper men fighting him for a single wire. All night long he hammered the "key" while the correspondents fumed and threatened.

The next day the scientific men met, pronounced the experiment a success, and passed resolutions of a complimentary character.

During the following week the public pulse reached normal, the nights being mosquitoless except for a few lonesome stragglers. The fatal gas diffused from two poles erected at either end of the marshes speedily put an end to all survivors and wigglers, and its use twice a week, at a cost of \$10 per month during the summer, brought final relief from touring insects.

Telegrams and letters of congratulation poured in from high government, state, and municipal authorities and from scientific institutions. The University of North America wired a free four-year course to each of the young chemists.

In the meantime the business feature had not been overlooked. Immediately after the first experiments Mr. Russell and Mr. Ferren had secured options for ninety days on real estate immediately adjoining the new city well, and, following the successful demonstration, had "closed the deal." A company was organized for the sale of the yellow mineral, the demand for it since the demonstration having become enormous. Last of all, the experiments with ferrenite, under the direction of the Bureau of Chemistry of the Agricultural Department disclosed the fact that the new mineral possessed medicinal properties of the highest value in blood diseases and rheumatism.

Zeb and Darwin were made officers in the company, and each received a liberal portion of the stock.

Even before university opening day arrived the profits had rendered outside assistance either for tuition or expenses unnecessary.

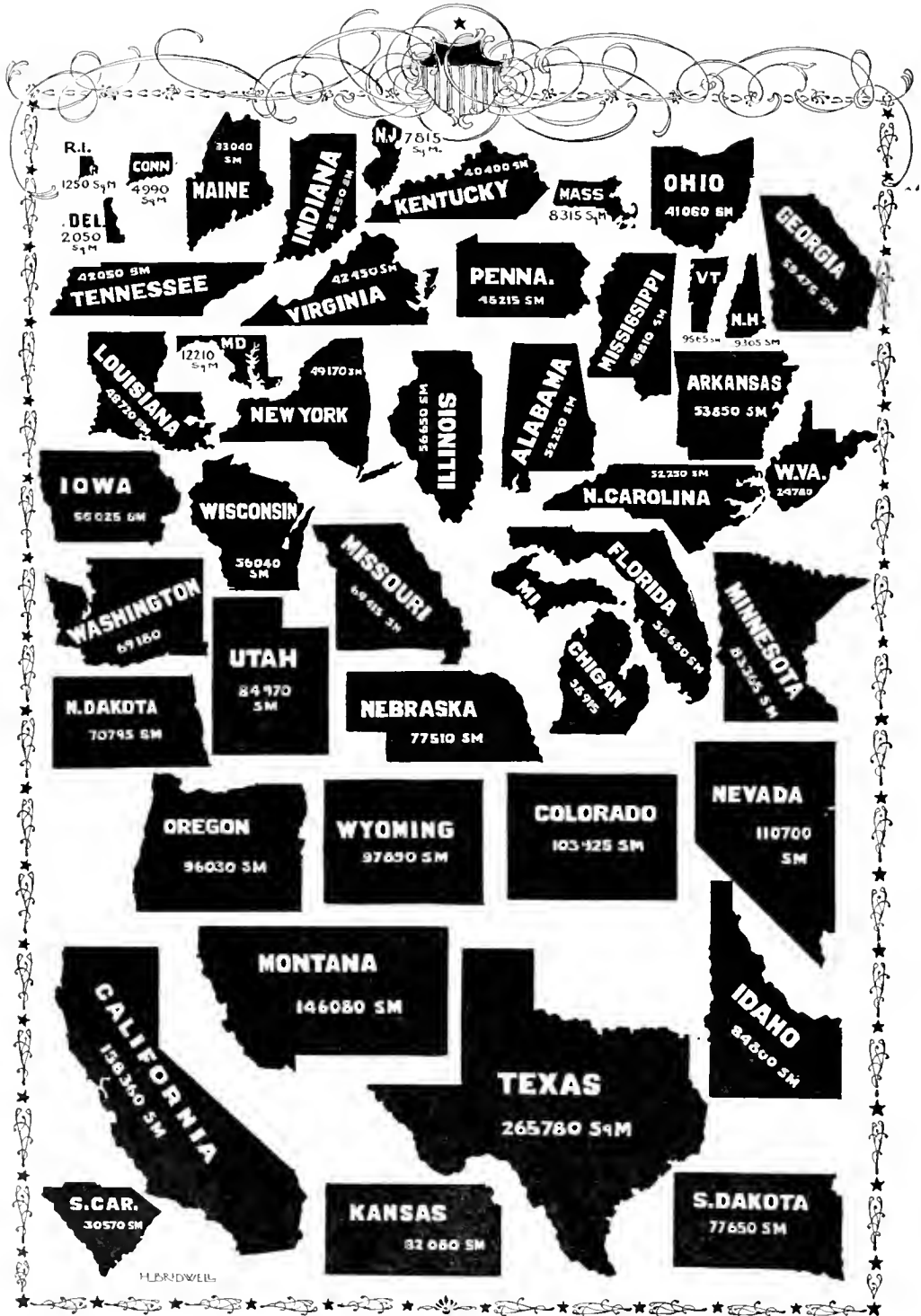

HENRI DWELL

PORTO RICO
3600 SQ. M.

OKLAHOMA
39030
SQ. M.

ARIZONA
113020 SQ. M.

NEW MEXICO
122580 SQ. M.

IND. TER.
31400 SQ. M.

★
COMPARATIVE SIZE
OF THE STATE OF
PENNSYLVANIA
45215 SQ. M.
★

HAWAII
6740 SQ. M.

PHILIPPINE ISLANDS
143,000 SQ. MILES

ALASKA
577390 SQ. M.

**THE STATES AND TERRITORIES
OF THE
UNITED STATES OF AMERICA**
DRAWN UPON THE SAME SCALE
SHOWING THEIR RELATIVE SIZE—THE STATE OF PENNSYLVANIA BEING CHOSEN AS THE UNIT OF COMPARISON.

H. BIRDWELL

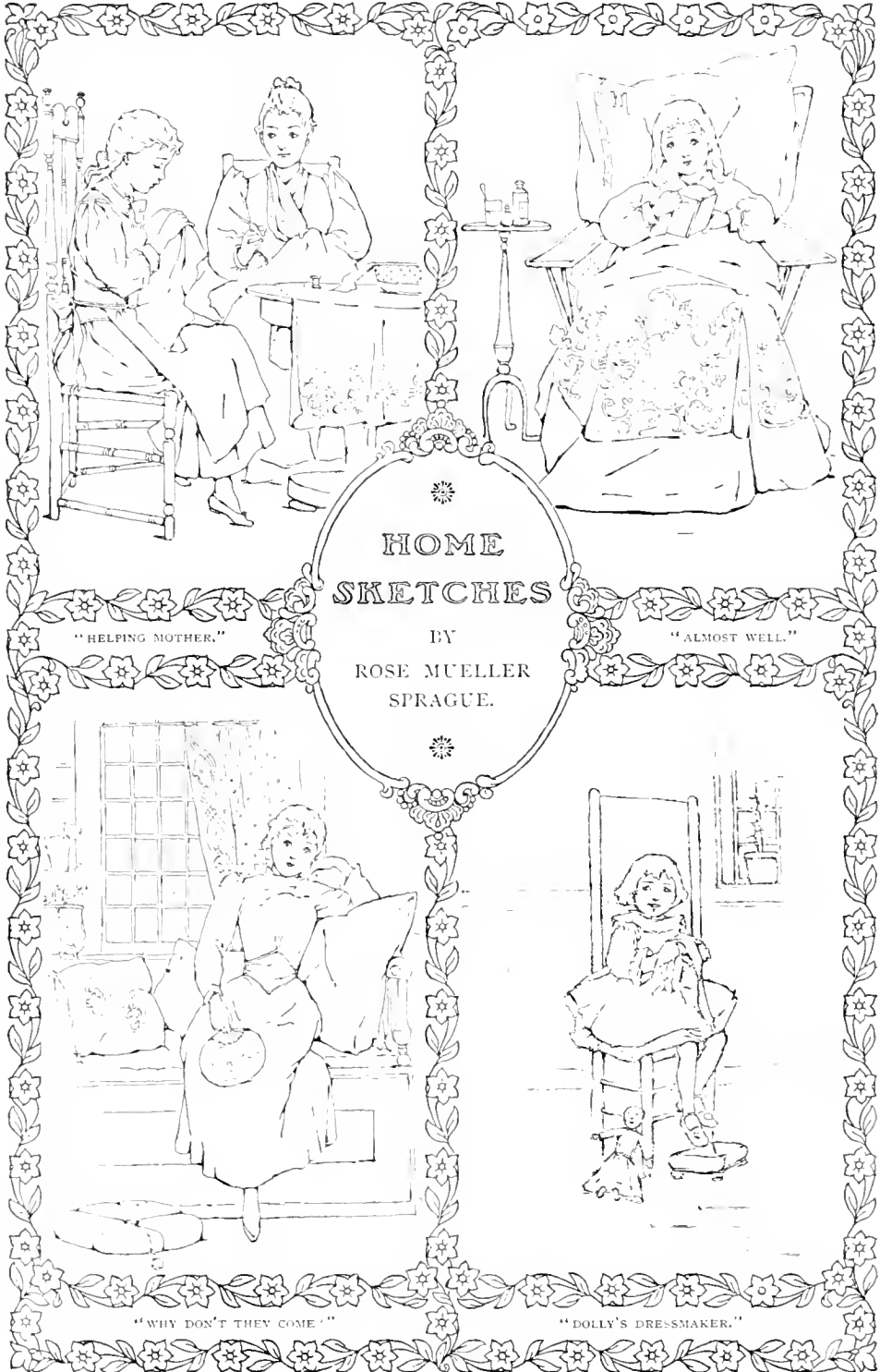

"HELPING MOTHER."



"ALMOST WELL."

HOME SKETCHES

BY ROSE MUELLER SPRAGUE.



"WHY DON'T THEY COME."



"DOLLY'S DRESSMAKER."



"GRANDMA'S EYES."

"BABY'S LONG WALK."

"AT THE SIDE DOOR."

"AT THE BACK DOOR."

THE PRACTICAL BOY.

BY JOSEPH H. ADAMS.

ELEVENTH PAPER.

THE HOME-MADE GYMNASIUM.

AN ATTIC GYMNASIUM.

IN Fig. 12 on page 1018, a very good idea is given for the arrangement of an attic gymnasium, in a room of about fourteen feet wide by sixteen feet long.

Under the trapeze or rings it is best to have an old mattress on the floor. Plenty of ventilation is necessary in the home gymnasium.

The following are descriptions of the method of making some of the simpler and less expensive forms of apparatus.

A FLOOR HORIZONTAL BAR.

THE hickory bar, $1\frac{3}{4}$ inches in diameter and 4 feet long, is supported on hardwood uprights 2 inches thick, 3 inches wide, and as high as the bar is desired—probably from 5 to 6 feet, according to the heights of the boys (see Fig. 1). At the lower end the uprights are held in position

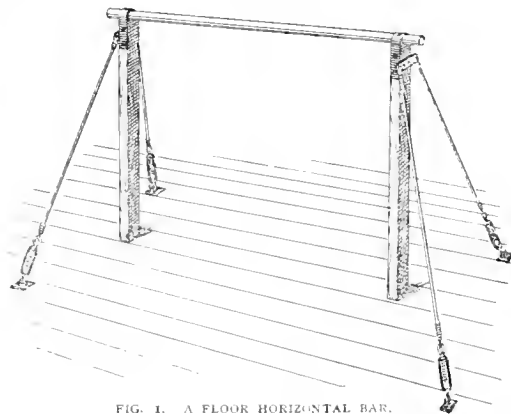

FIG. 1. A FLOOR HORIZONTAL BAR.

by two half-inch iron pins driven into the bottom, which fit into holes made in the floor in a corresponding position as shown at A in Fig. 2. The upper ends of the uprights are cut with a

compass-saw to receive the bar, and the edges are tapered to meet the edges of the U cut (as shown at B), and when the bar is in place it is held with straps made of one-eighth-inch iron and provided with screw-holes, as shown at C.

The ear-plate attached to each upright under the bar, and to which the stanchion-wires are fastened, is made of one-inch tire-iron, and securely bolted to the wood, as shown at D. Four turn-buckles and some stout wire form the stanchions, and the floor-plates should be diagonally located so that they not only support forward and backward but from side to side.

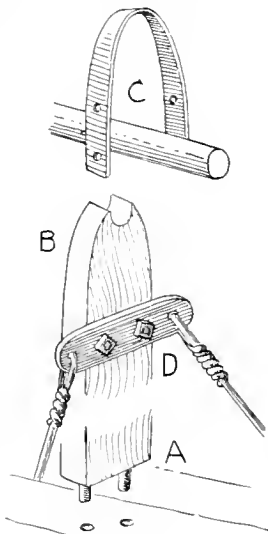

FIG. 2. DETAILS OF FLOOR HORIZONTAL BAR.

PARALLEL BARS.

THE bars shown in Fig. 3 are of hickory, 5 feet 6 inches long, and 2 inches in diameter. The uprights that support them are of oak, ash, or other hard wood $2\frac{1}{2}$ inches square and 42 inches long. The lower ends are let into bases of heavy hard wood, 2 inches thick, 10 inches wide, and 3 feet 6 inches long. Square holes are cut in the middle of these bases, two feet apart, so that eight inches of wood beyond the holes at each end act as a platform on which to screw the bracket-ends that form braces to the uprights. The holes must be cut with a bit all the way through the bases and trimmed with a mortise-

chisel and mallet, taking care to make them very accurate, so there will be no play to the uprights when driven in the holes. The stepping-plank is of hard wood also, 12 inches wide, 1½ inches in thickness, and long enough to span the cross-planks, so the distance between uprights will be 4 feet. Hollows are cut out in the top of each upright with a compass-saw, and the sides slightly tapered to the edges of the U cuts, so as not to interfere with the hands when acting on the bars. Fasten the bars to the uprights with two slim screws at each side driven through the uprights and into the under sides of the bars, but do not drive a screw or nail down through the bars into

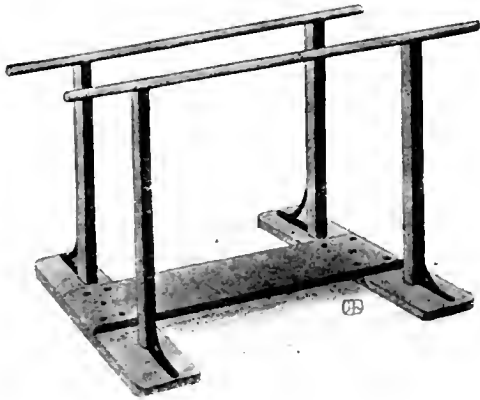

FIG. 3. PARALLEL BARS.

the top of the uprights, for it weakens the bars, and if the weight is borne at the ends it might snap them off. At a hardware-store, purchase four iron brackets with eight-inch tops and ten- or twelve-inch sides.

Invert them and screw the tops to the baseboards and the sides to the outer edges of the uprights, to add rigidity to the bars.

A coat or two of paint will improve the appearance of the uprights and base, but do not coat the bars with anything, just polish them with a rag and the hands.

TRAPEZE-BARS.

For the house gymnasium a good trapeze-bar can be made 4 feet long, 1¾ inches in diameter, and cut with a path at each end (as shown at B in Fig. 4), so that the strap can be wrapped around it and drawn tight. The bar should be made of well-seasoned hickory.

An adjustable flying trapeze (as shown in the illustration) is made from two trunk-straps, provided with two extra loops and a four-foot bar, cut from two-inch hickory and shaped with a spoke-shave, as shown in the drawing. At the ends paths are cut to receive the straps; but if it is possible to have the bar turned in a lathe, a more accurate result will be had, as the lathe will insure a perfectly round bar, while the hand-made one could not be cut so regularly. Small rings at the upper ends of the ropes or straps, and hooks, driven securely into the ceiling beams, will suspend bars or flying rings.

The bar may be suspended by ropes, as shown at C in Fig. 4, or may be adjustable by being made of trunk-straps, as shown at A.

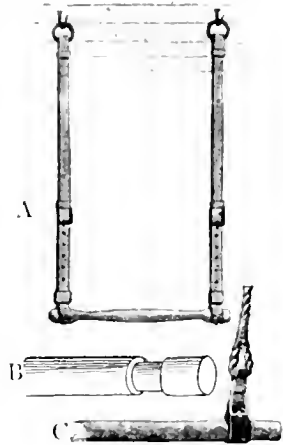

FIG. 4. TRAPEZE-BAR AND DETAILS.

SWINGING RINGS.

EXERCISING and swinging rings are made from 6 to 10 inches in diameter, outside measure, and they can be purchased for one or two dollars per pair, according to the size and finish.

A blacksmith will make you a pair of rings, 8 inches in diameter and of 5/8-inch round iron, for about fifty cents a pair; and with a fine file and emery-cloth they can be smoothed, so that they will be comfortable to the hands.

The boys should have rings on which a good grip can be taken, and there is nothing better for this than to bind them with tire-tape, or to sew leather around them, making the join at the outside. The sewing can be done with doubled and waxed linen thread; but if it should prove too difficult a shoe or harness maker will help you out in a very little time for a small sum.



FIG. 5. A TRIANGULAR SWINGING RING.

In Fig. 5 a triangular "ring" is shown having the lower side bound with tape or leather. The triangle is 6 inches across the bottom, 8 inches high, and made from half-inch round iron. The rings or triangles should be suspended by means of ropes, at the lower ends of which straps are provided so that they will hold rings, rods, or trapeze-bars.

The rope-ends, through which the straps are caught, can be spliced or formed into a loop-end and bound tightly with twine to make a strong union. The former is the better way.

WANDS AND BALL-BARS.

WANDS, three to five feet long, can be cut from any hard wood, but if a one-inch curtain-pole can be had, it will make two wands by being cut in two. A ball-bar or wand can be made as described for the dumb-bells by boring croquet-

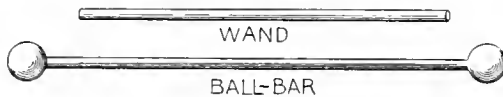

FIG. 6. EXERCISING-WAND AND BAR.

balls and attaching them to the ends of a bar with wedges, as shown at Fig. 6.

In many schools they have calisthenic exercises with wands, dumb-bells, and ball-bars, so that for light exercise it is interesting to repeat the movements of the school instruction.

DUMB-BELLS.

To make the dumb-bells, obtain some old croquet-balls and clamp them in the vise of a carpenter's bench, and with a one-inch bit bore a hole through the ball. Cut a broom-handle or a one-inch curtain-pole in lengths twelve or thirteen inches long for handles, and in the end of each make a saw-cut. Smear the outer end of each stick with glue and drive it through the hole in the ball, and keep it firmly in place by driving a wedge into the end of the stick, the same as hammer-heads are fastened to prevent their coming off. Some glue should be placed in the saw-cut, so as to hold the wedge when it is driven home.

To make the handle between the balls easier to grip, it can be bound with linen or cotton

fish-lines; then the balls may be painted or varnished, and the line given a coat of black varnish, which will set the cord-made binding and harden it.

Several sets of these bells can be made for the "gym," and hung against the wooden band that extends around the room.



FIG. 7. DUMB-BELLS.

In the absence of iron bells, a heavy pair can be made with gas-pipe handles and flanges with screw-holes, that can be fastened to wood blocks 4 inches in diameter (see E in Fig. 7). The gas-pipes, an inch in diameter, can be had at a plumber's or gas-fitter's shop, and they should be 5 inches long, threaded at both ends and screwed into flanges fitted with threads to receive them, and in turn bored with holes, so ordinary wood-screws may be passed through them and into the wooden ends. The gas-pipe may be bound with cord and painted or varnished, or to represent iron the entire bell may be painted black.

INDIAN CLUBS.

Use two pieces of spruce, chestnut, or apple-wood, and with a draw-knife, taper the upper end, so that it is $1\frac{1}{2}$ inches in diameter and leaving the base about $2\frac{1}{2}$ inches in diameter, the thickest part being nearly midway between top and bottom.

The tapering is done by holding the wood in a vise and gradually shaving away the wood with a sharp-bladed draw-knife or spoke-shave, turning the wood frequently so as to cut the butt evenly and as true as possible.

A one-inch hole is bored in the top of each club 3 inches deep, with a bit, and into it a broom-stick or old rake handle is driven and held in place with glue and a few steel-wire nails.

Small wooden balls are bored and glued to the top of the handles and given additional security with small nails.

The handles can be bound with fine cord, and the exposed woodwork painted any desirable color. Of course if the boy has a lathe it will be best to turn the Indian club in one piece.

STRIKING-BAGS.

FROM oak, ash, or other hard wood, 2 inches thick, cut a base 15 inches square, and round the edges off on the upper side, as shown in Fig. 8. Make a hole in each corner through which to pass a screw, and a large one at the middle to receive a spiral spring. The staff is screwed down into the top of the spring for five or six inches, or enough to hold it securely, and at the bottom a spring is held in the block with some screws or nails driven at the bottom, through the wires of the spring and into the wooden base. When using the bag it should be fastened to the floor with two or three screws, so it will not topple over; and as it is struck it bends over from the bottom, and the spring, if stiff enough, will cause it to rebound or come to an erect position instantly.

A striking-bag and disk like the one shown in Fig. 9 can be made by a boy, from wood and leather, thumb-nuts, and a pair of braces. A striking-disk must be stout, and substantially hung. From the illustration (Fig. 9) any boy can construct an adjustable disk. Note the set-screws at the sides and the braces above. The disk is made of 1½-inch hard wood. At A in Fig. 10 is shown the bolt on which screws the thumb set-nut.

The bag is an inverted balloon-shaped affair, and is made of six pieces of leather or canvas, 5½ inches wide and 15 long, sewed together at the edges. Each piece is shaped like B in Fig. 10, and when they are sewed together a round cap or end-piece is made fast to the large end, to secure the ends of the side pieces.



FIG. 8. A FLEXIBLE-STAFF STRIKING-BAG.

A patch is sewed along the edges of two sides to strengthen them, and to pass the lacings through, as shown at the upper right side of B in Fig. 10. This permits an opening through which

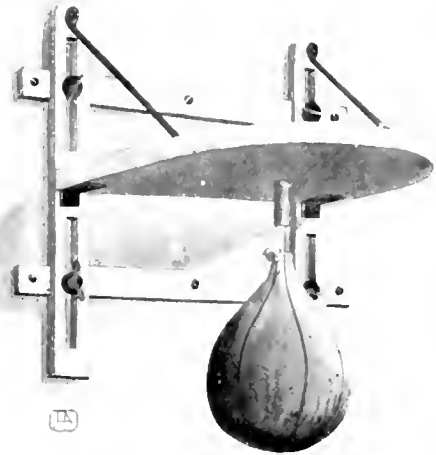

FIG. 9. STRIKING-BAG AND DISK.

to pass a filling of rubber scraps and bits of leather, but if a rubber bladder is to be inserted and inflated, this opening will not be required; as the bladder, when collapsed, can be pushed within the opening at the neck. One inch below the top of the neck, some slits are to be made in the leather through which the throat-laces are interwoven; when the knot at the end of the suspension-rope is inserted in the throat of the bag, the laces are drawn tight and tied.



FIG. 10. DETAIL OF STRIKING-BAG AND SUPPORT.

And by means of a hollow stick, which projects down five inches below the under side of the disk, the bag is centered and held rigidly so that it flies up on all sides from this center-drop when struck from different sides.

MEDICINE-BALL.

A "MEDICINE"-ball, so called from the fact that exercise with it is better for the body and system than medicine, is 10 inches in diameter, and weighs from three or four to six or eight pounds, according to the size of the boys and girls who use it.



FIG. 11. MEDICINE-BALL AND DETAIL OF ONE SECTION.

The case of a round football may be used, or a leather case can be made of six pieces and two ends, so that it will lace up, as shown in the Fig. 11.

The ball is filled with pebbles or small stones

come in contact with the leather. Larger or smaller stones can be used according to the weight desired, or sand wrapped in paper may be used in place of the stones. If the case is to be made, obtain some russet leather from a shoemaker, and cut six pieces 14 inches long and 6 inches wide, as shown at F in Fig. 11, and with linen thread, doubled, sew the edges together, so the seam is at the inside. Reinforce two sides of adjoining strips with a patch of leather sewed securely all around the edges and through the middle. At the open ends of the leather case, sew on circular patches 4 inches in diameter to securely hold the ends of the six leather sides.

The foregoing descriptions have included but a few of the items often found in a well-stocked gymnasium. It has been the intention to let these descriptions serve as well for others not here mentioned, as, for instance, the pulley-

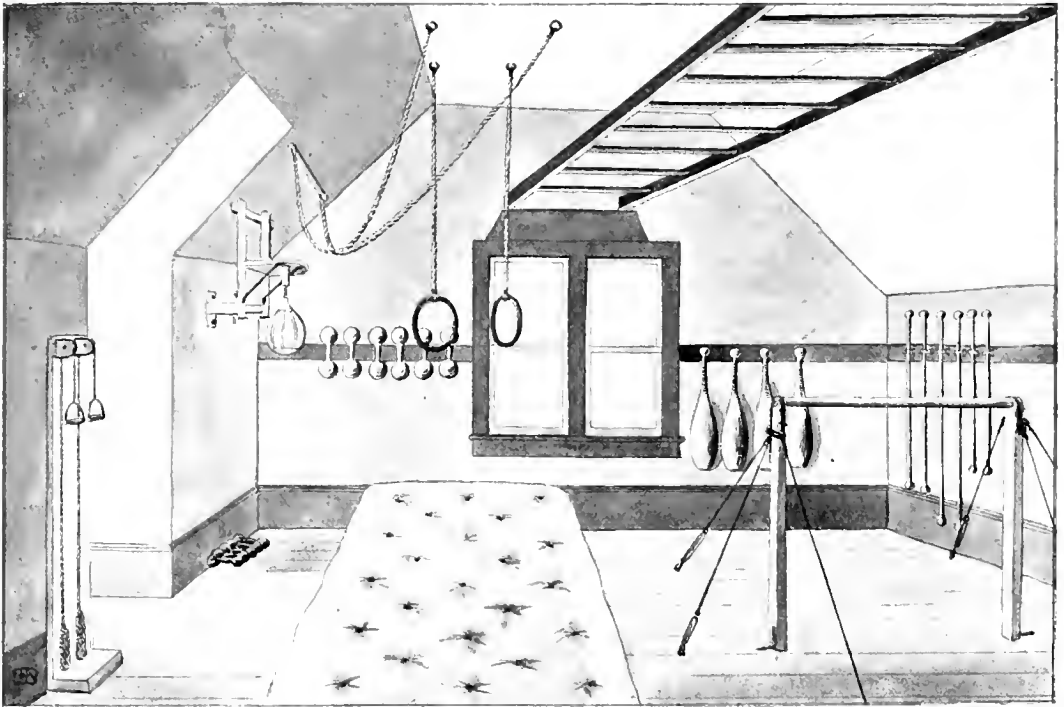

FIG. 12. GENERAL VIEW OF A HOME GYMNASIUM.

wrapped in newspaper, making small individual balls of them and stuffing them in the case. The newspaper makes a soft cushion and does not allow the hard or sharp edges of the stones to

weights shown in Fig. 12 on this page, etc. The boy who has followed the descriptions in this article will be capable of making any other pieces of apparatus he may wish.

A CHIMNEY-SWIFT'S NEST.

BY RUSSELL M. CORYELL.

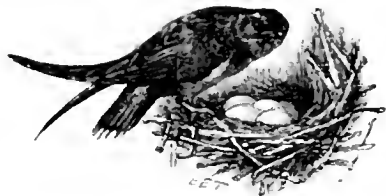

ONE morning late in June I climbed to the top of our house to look around the country. I had not been there

long when I felt a rush of air on my head and I saw a chimney-swift, improperly called a chimney-swallow, flying away for another swoop at me. I then realized that I must be near its nest, and, looking down a chimney near by, I saw, after my eyes had become used to the light, a nest within three feet of the top with five pure white eggs about a half an inch long in it. It was the first time I had ever known a chimney-swift to build so near the top of a chimney, for usually it builds some few feet down where there is a bend which keeps out the rain that would soften the glue with which the nest is held together.

I thought it would be interesting to take a picture of the nest, and this being such a good chance I did so, much to the dislike of the birds who kept making swoops at me.

The nest of a chimney-swift is not made, like that of most birds, of hair, leaves, or grass, but of small twigs which the swift gathers while flying, and which are stuck together with the bird's saliva, which is glutinous.



"LOOKING DOWN A CHIMNEY NEAR BY I SAW A NEST WITHIN THREE FEET OF THE TOP."

sometimes to fly a thousand miles in twenty-four hours. Chimney-swifts are good friends of the fire insurance companies because they knock the soot down and make it less easy for the chimneys to catch fire.

TIMMY TOOLE AND WILLIE WISE.

BY LOUISA FLEETNER TARKINGTON.

Said Timmy Toole, "I wish I knew
As much as Willie Wise,
He always has his 'rithmetic,
And wins the spelling prize."

Said Willie Wise, "If I could play
Base-ball like Timmy Toole,
And win the tennis-match, I'd be
The happiest boy in school!"

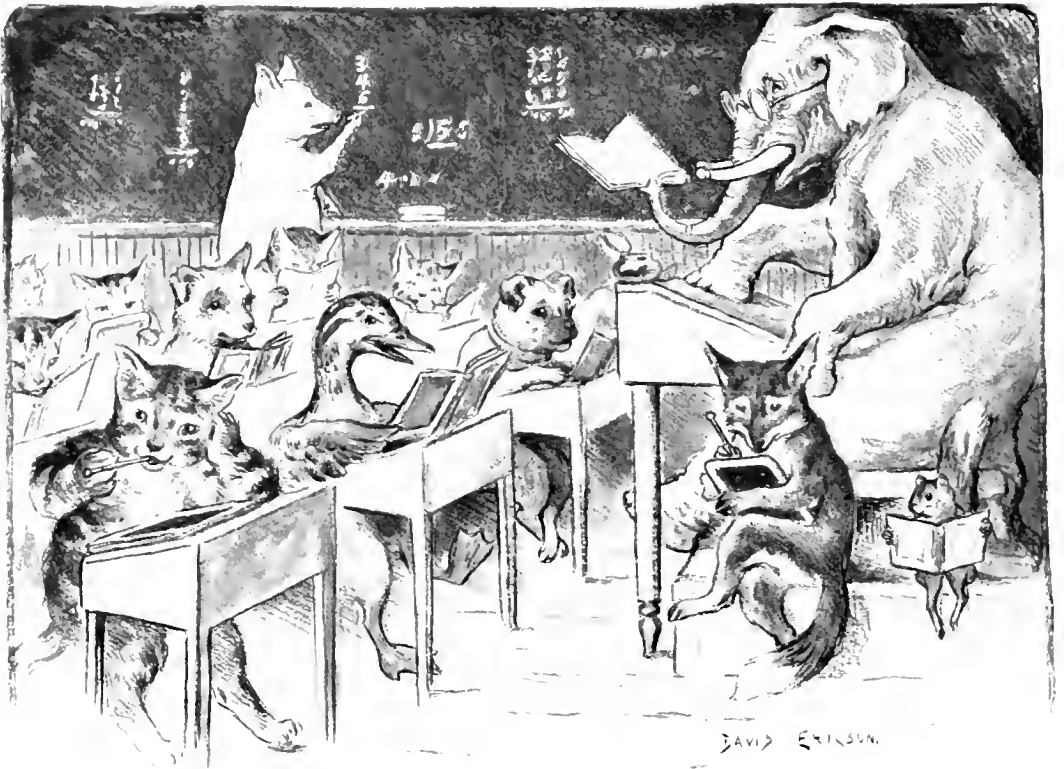

THE ELEPHANT AND HIS SCHOOL.

BY ELLEN V. TALBOT.

The great white elephant left the show,
 He said he was too refined;
 The ways of a circus did not suit
 His most superior mind.

"A creature as big and wise as I
 Should be teaching school," said he;
 "And all the animal little folk
 My scholars they shall be."

So into an empty school-house near
 He marshaled them all one day;
 ("T was in vacation-time, and so
 The children were all away).

The kittens and puppies, the pigs and geese,
 Were put to work with a will;
 But the squirrel and fox to the platform went
 Because they would not keep still.

And then he began to teach his school
 The various things he knew:
 "There's much not down in the books," said he,
 "That you ought to know how to do."

And first he showed how to flap the ears,
 But their ears were far too small;
 And then he showed how to wave the trunk,
 But they had no trunk at all.

The only thing that he taught his school
 That the scholars accomplished well,
 Was when he called in the peanut-man,
 And taught them the nuts to shell.

The elephant soon dismissed his school,
 And packed up his trunk to go;
 "For, after all, my talents," said he,
 "Are best displayed in a show."

FIRST AID TO THE INJURED.

BY DR. E. E. WALKER.

V. POISONS.

ONE day, as the boys and their tutor were clambering over stones, poking about in the hope of finding some relic, Mr. Wilson exclaimed, "Look out for that poison-ivy, boys!"

"But I thought the poison kind had only three leaves and this has five," cried John, who had gone some distance from the others.

"There are two kinds of ivy here," replied Mr. Wilson: "the one which you are looking at, John, is the Virginia creeper; in the fall this ivy has dark-blue berries. We are looking at some *poison-ivy* over here; its berries are white and it has three leaves."

"Well, I guess I know the difference," said Abe. "Do you see my hand?"

"Yes," said Mr. Wilson; "I've been wondering what was the matter with it."

"Well, I was poking around, yesterday, in the woods, and I was careless, I s'pose, because this morning when I woke up I found I'd poisoned myself."

"How did it feel?" asked John.

"It burned and itched, and it was all broken out in red blotches and blisters."

"But what did you do for it?" asked John.

"Mother wet some pieces of cloth in water and baking-soda, and the itching stopped after a little while."

"How much baking-soda did she use?" said John, who always became interested in anything of this kind.

"A tablespoonful in a teacup of water."

"Here's your old friend baking-soda again," said Mr. Wilson; "you see, we use it for burns, for sunburn, and for eruptions caused by poisons on the skin. Were any of you ever poisoned inside?"

"I was," said Abe, who had proved such a jolly companion, that the boys had again invited him to join them; "it was over here on the island that I ate some poke-berries last summer, because they looked good and juicy."

"What did you do for that?" said the inquisitive John.

"Mother gave me a lot of warm water, a pint at a time, and once or twice some with a little mustard in it."

"What did that do to you?" said Jerry. "Gee, I'm glad I did n't eat any poke-berries!"

"I got sick at my stomach and it all came up," said Abe, "and then I felt better, only I was so cold that mother put me to bed in warm blankets and gave me hot coffee to drink."

"Your mother could n't have done any better if she had been a doctor," said Mr. Wilson, "for she attended to the main things. She got rid of the poison first and then braced you up afterward. There are many poisons however that have to be treated in special ways. They need an antidote."

"That's a funny word," said John. "What does that mean, Guardie?"

"Well, it means something like this: when the cook's baby drank lye she had to have an antidote—in other words, she had swallowed an alkali, and she had to take an acid, which is an antidote for an alkali. You remember they gave her lemon-juice; that's an acid."

"Why could n't they have given her vinegar?" said John. "Is n't that an acid?"

"Yes," replied Mr. Wilson, "it would have been very good, too."

"I should think that sometimes people would take acids and get poisoned," said John.

"You are quite right," said Mr. Wilson; "they do, and then you have to give them an alkali, which would be, for instance, aromatic spirits of ammonia, or our friend baking-soda; but another thing, the acid would injure the walls of the stomach, and you would give milk, or the whites of eggs, or flour stirred in water besides."

"Well, I fear it's going to be rather hard work to study medicine, if this is a part of it, Guardie," said John; "but, I think I'll like it."

PINKEY PERKINS: JUST A BOY.

BY CAPTAIN HAROLD HAMMOND, U. S. A.

VIII. HOW PINKEY TRIUMPHED BY DIPLOMACY.

"PINKEY" PERKINS had thought in the past that he had drained the cup of bitterness to the dregs. But his former troubles were mere ripples compared to the waves of depression that now submerged him. Hattie Warren, the only girl he ever had loved or ever could love, had given him "the mitten."

"Bunny" Morris's aunt was getting up a birthday party for him, and it was to be a surprise. Everybody in school knew about it except Bunny, who, in spite of mysterious references to "next Friday night," uttered in his presence, remained suspiciously stupid and indifferent.

For days Pinkey had looked forward to the joy he was to experience in escorting his Affinity to the party. To be sure, he had said nothing to her of his aspirations. That must necessarily be done by sending her a formal note, "requesting the pleasure of her company." He could not with propriety send it before he received his invitation. He was sure he would get one, but to anticipate it would be out of the proper order of things.

Do not think Pinkey had the field all to himself. He had a rival for the affections of his Affinity in Eddie Lewis. Recently he had thought that Eddie was gaining ground, but he believed things were now turning in his favor. He had walked home from Sunday-school with his Affinity two weeks in succession. He felt that he was justified in his belief that his star was bright with promise.

Tuesday morning came, and with it word that the invitations were out. Mrs. Morris had allowed Bunny to go to school that morning before the first bell, and later had hailed "Putty" Black, as he passed, and had given him the invitations to distribute.

"Be careful Bunny does n't see you with them," she said in warning, as she gave him the shoe-box containing the envelopes.

"Yes, 'm, I will," said Putty, as he hurried off, proud of his part in the proceedings.

Going across the public square, Putty met Eddie Lewis and gave him his invitation.

"Let 's see who all 's a-goin'," said Eddie, taking the box and scanning the addresses.

"There 's twenty-nine invited," said Putty: "fourteen boys and fifteen girls. That 's so 's Bunny can take Bess Knapp home. I 'd laugh if she would n't let 'im."

Thus discussing the party, and who would take whom, and whether or not Bunny knew about it, the two wandered schoolward. On the way they encountered several of the favored ones and gave them their invitations. No one inquired whether or not he or she was invited. All retained an unconscious air when hailed, and received their invitations without betraying the anxiety they really felt.

As Putty and Eddie entered the corner turnstile, they saw Pinkey coming to school. Pinkey had been told that Putty had the invitations, and momentarily expected to be called to receive his. There must be one for him, since it was a part of the program that all were to meet at his house and descend on Bunny in a body. But Putty said nothing, and Pinkey would have died rather than ask if there was one for him.

Fearing to appear concerned at the seeming slight, Pinkey studiously avoided Putty all that morning, and when the bell rang he went in last. Every one who had an invitation made a show of secrecy "for fear of letting Bunny know." Yet there seemed to be a very unconscious display of similar envelopes under cover of slyly-opened books. Pinkey's heart sickened as he passed the desk where sat his Affinity and saw that she had one.

Recess came and went, but no invitation for Pinkey. His pride kept him from appearing

gloomy, but his indignation almost got the better of him as he was repeatedly forced to say, "Not that I know of," when asked if he was invited. By noon he was miserable, for by that time there was no doubt that he had been slighted. And Bunny was his chum, too!

As he entered the turnstile after dinner, he found Putty Black there waiting for him.

"Here's a note for you," said Putty; "don't let Bunny Morris see it"; and, with some lame excuse about meaning to give it to him before, he ran back to the game of "scrub" he had left when he saw Pinkey coming.

Instantly all the clouds cleared away and Pinkey was himself again. As soon as school opened, and the pupils settled down to work, Pinkey barricaded his desk with his geography and began his note to his Affinity. For days he had kept paper and envelops secreted in his desk, awaiting this happy hour.

Three times he wrote and three times he tore his paper in small bits and put the scraps in his pocket. "Red Feather," the teacher, had, on occasions, put together the small pieces into which notes had been torn and left on the desks, and had copied the restored notes on the blackboard. By this means she hoped to discourage what she considered a very serious menace to school discipline.

Finally, Pinkey composed a note which seemed properly formal and polite. It ran:

Pinkerton Perkins requests the pleasure of escorting Miss Warren to the party next Friday night at Bunny Morris's house. Please answer. Everybody is to start from my house.

He hid his note in his geography and waited for dismissal time. Then, to carry out his idea of formality, he bribed a smaller boy to deliver the note to his Affinity at her home. To make sure that the note reached its destination safely, he shadowed the messenger by going across lots until from a distant shed he saw the note delivered into the proper hands.

He waited what seemed an age before he saw the door open and the reply placed in the boy's hands. Then he left his hiding-place, and soon after contrived to meet the boy unexpectedly. He looked at the tightly sealed note, and somehow feared to open it.

When considering a question of unusual importance, it was a habit of Pinkey's to retreat to the woodshed and think it all over.

Ten minutes later, with heart thumping and fingers trembling, he was perched on a pile of wood, opening his note. Here is what he read:

Harriet Warren regrets she cannot accept Mr. Pinkerton's kind request. Her company for next Friday evening is engaged.

The shock he experienced made his blood run cold. He read and re-read the fatal note.



"HE SAW THE NOTE DELIVERED INTO THE PROPER HANDS."

He could not believe his hopes had been so blighted. But there it was in black and white. There could be no mistake. His first impulse was to tear the paper into bits; but, on second thought, he decided not to do this. *She* had written it, and since he had resolved to love her, and her only, until death, he decided to keep even this, as it might prove to be the one solitary memento to cheer his desolate life.

Sadly he replaced the note in the envelop, folded it in his handkerchief, and carefully put it away in his pocket. Then, with his chin in his hands and his elbows on his knees, he began to consider what the future had in store

for him. One thing was settled. Never again would he be attracted by the society of girls. The one girl in the world had given him "the mitten" without any word of excuse, and he



L

"HE COULD NOT BELIEVE HIS HOPES HAD BEEN SO BLIGHTED."

would never trust one of them again. Now that all the happiness had gone out of his own life, he would devote himself to the endeavor to make others happy. Strange to say, he felt no hatred toward the author of all this sorrow that lay on his heart. Perhaps, if he studied hard and went to college and became a great man, she would be sorry some day that she had treated him so. Then he would come back to the little town and visit the scenes of his boyhood. And then, one day, he would meet her alone in some leafy lane, and with tears in her eyes she would tell him how sorry she was that she had blighted his life, and how unhappy she had been since she had wronged him.

Then he would take from his pocket the time-worn note that had so changed his life, and would silently place it in her hands. At the thought that he had cherished it all those years she would weep over it, and would ask if there was any way she could make him

happy. Then he would tell her that it was too late; that his life had been cheerless for so many years that he must now live it out as she had decreed in the past. Finally he would leave her there, repentant and sad that she had brought everlasting desolation into two lives by a rash act of her childhood.

Having thus settled his future clearly in his mind, Pinkey felt a calmness steal over him. He felt a superiority over those who had never had any real trouble in their lives. He would not bother his mother with his sorrow. He could bear it alone.

So effectually did he work on his own feelings, that at supper he was actually cheerful and had fully regained his appetite.

The next three days were trying days for our hero. Every one in school knew that Hattie Warren was going to the party with Eddie Lewis, and also knew that she had refused to go with Pinkey. However, no one mentioned either of these facts to him, for all knew how serious a matter it was, and how effectually he would resent such a reference. He tried

to act as usual and even to appear quite indifferent. He took part in all the games with even greater vim than was his wont.

Whenever his Affinity was near he was especially vigorous in his play. Never a glance in her direction, however, betrayed his knowledge of her presence.

Friday night came, and, with the exception of Eddie Lewis and Hattie Warren, all who were going to the party assembled at Pinkey's house. They went to Bunny's in a body, and, after approaching the house on tiptoe, burst violently in at the front door. They found Bunny wrestling with the "greatest common divisor" and the "least common multiple," yet he was attired in his Sunday best. However, he was genuinely surprised and greatly delighted.

After being subjected to a vigorous pounding on the back, once for every year he had lived and several "to grow on," he was presented with various and sundry handkerchiefs, vases, neckties, bottles of perfume, and other articles too numerous to mention.

Speaking literally, the party was a howling success. In spite of his recent sorrow, Pinkey

was the life of everything. He organized games of "Clap in and clap out," "Post-office," and "Heavy, heavy, heavy hangs over your head," acting as postmaster and auctioneer. His energy in making all enjoy themselves was admirable, and his attitude toward Hattie Warren was such as to make her very unhappy. Had he ignored her, it would have shown her that he resented her refusal to go with him. Had he shown her undue attention, it would have indicated weakness.

But to have him do neither made her think she had probably done wrong in not waiting for his invitation instead of accepting the first one she received.

By Monday, Pinkey's air of resignation to fate had begun to desert him, and a feeling of bitterness took possession of him. Bunny Morris did not realize on what dangerous ground even he was treading when he asked Pinkey that morning: "What made you let Eddie Lewis take Hattie Warren to my party?"

Whereupon Pinkey replied viciously: "I did n't let 'im. S'pose I 'm Hattie Warren's guardian? Ask her."

"What 'd she say when she gave you 'the mitten'?" urged Bunny.

"That 's for me to know and for you to find out," said Pinkey, entering the schoolhouse.

After recess Bunny made frantic efforts, by sign language, to transmit to Pinkey some message. Pinkey could not understand, and made motions to write it on paper and throw it over. After scribbling for a few moments, Bunny folded the note tightly, and when an opportunity came shot it across the room to Pinkey.

Pinkey did not take his eyes from the note

until he had read it all; but from the way he occasionally twisted his head sidewise, Bunny knew that he was "mad." After reading it a second time, he folded it and laid it carefully on his desk. Presently he saw Red Feather looking in his direction. Hastily picking the note from his desk, he began tearing it to pieces.

Without saying a word, Red Feather stalked majestically down the aisle to Pinkey's desk and held out her hand. With apparent re-



"LOOK HERE, EDDIE LEWIS," CRIED PINKEY: "WHY DON'T YOU CHOOSE SOME FELLOW OF YOUR OWN SIZE!"

luctance, Pinkey dropped the pieces into her open palm. Then, maintaining her impressive silence, she returned to the platform. For about five minutes she busied herself at her desk, then she rose and went to the blackboard. Picking up a piece of crayon, she wrote:

F. L. told me at recess, and made me promise not to tell anybody, that he give P. B. two crockeries and a chinie middler not to give you your note to come to my party till after he had asked H. W. to let him take her. And he give him a bean-shooter too. Don't you tell anybody, but if I was you I would get even.

As was her custom, Red Feather made no comments. It was her theory that when notes were found and copied on the blackboard, the shame and blushes of those concerned was the best punishment.

Pinkey was overjoyed at the outcome of his master-stroke of diplomacy, in the success of which Red Feather had so unwittingly assisted him. Everyone in the room except Eddie Lewis looked at Pinkey, admiring his diplomacy.

Bunny, however, was much disturbed over the publicity given his note, for he feared Eddie Lewis would "lay" for him. His fears were well grounded. When school was dismissed he had scarcely got outside before Eddie took him to task for "tattling to Pinkey." A wordy war ensued and a crowd gathered.

When Pinkey reached the door he heard the high words and immediately suspected the cause. Rushing into the crowd and elbowing his way to the front, he shouted, "Look here, Eddie Lewis; why don't you choose some fellow of your own size? If there 's anybody to fight, it 's me. I let Red Feather get that note on purpose, and if you want to settle the score with me, just you try it on."

This was an unexpected turn of affairs for Eddie, and he endeavored to descend gracefully from his lofty pedestal.

"Aw, I wuz just a-funnin'," he explained. "I just wanted to see what Bunny 'd say. We wuz n't a-goin' to fight, wuz we, Bunny?"

Bunny said he did n't know, but he agreed that *he* was n't trying to "pick a fight."

This ended the controversy. The crowd reluctantly dispersed, each boy relating just where he was when the quarrel began, just what Bunny said, and just what Eddie said, and how Pinkey took Bunny's part.

When Pinkey came to school that afternoon he was in the position of a hero. He had been vindicated in the eyes of his Affinity and he had settled with Eddie by making him back down after he had challenged Bunny. As Pinkey passed the seat where sat his Affinity, he looked straight ahead, entirely oblivious of a look from her for which he would have given his soul.

After the opening exercises, Pinkey began to study his arithmetic lesson. When he opened his book his eyes almost started from his head. There, between the pages of the day's lesson, was a note addressed to him in the handwriting of his Affinity.

Regardless of Red Feather and of every one else, he feverishly tore it open and devoured the contents. Just as he finished he was hurled from the seventh heaven of bliss to the depths of despair as the word "Pinkerton!" smote his ear. Red Feather stood beside him!

"Give me that note," she sternly demanded, holding out her hand toward the missive.

Pinkey attempted to destroy it, but Red Feather was too quick for him and took it from him before he could damage it. Pinkey was on the verge of open rebellion as he pictured the humiliation of his Affinity when the contents of that note were written on the blackboard. He started up to follow the teacher to her desk, but on second thought he saw the uselessness of such a move.

He could only sit and harbor dire threats of revenge as Red Feather seated herself and began to read the note. She did read it too, not once but several times. Here is what she read:

FRIEND PINKEY: I am so sorry I rote what I did last tuesday. When Eddie Lewis asked me I was mad because you did n't ask me first. I went with him just for spite. I am glad Red fether found Bunny's note and rote it on the board. Now I know why you did n't ask me before.

I hope you are not mad at me.

your true Friend,

HARRIET WARREN.

P.S. I am glad you did n't let Eddie Lewis whip Bunny.

P.S. (2). I am going to sunday-school sunday.

We must give Red Feather credit for remembering that she was once a little girl herself and had had childish little love-affairs too. Be it said in her praise that she carefully replaced the note in the envelop, walked back to Pinkey's desk, and, with a look of tenderness in her eyes that he had never seen there before, restored to him the precious letter.

THE ELF'S ELECTRIC FAN.

BY PETER NEWELL.



WHENE’R this stuffy, puffy scribe
Sets out to write a diatribe,
Or aught else that he pleases,
A busy, buzzy bumblebee,
Perched on his desk, sagaciously,
Supplies him cooling breezes.



THE DIFFERENCE.

BY CAROLINE McCORMICK.

THIS is my dog, my very own. You 'll think it strange, but we
Have ages that are just alike, and I am young, you see,
While he 's as old, or most as old, as any dog can be.

He is no higher than my waist, and he is grown up, too,
And I am quite as tall as Jane, and I 'm not nearly through
With growing, for I mean to be as big, perhaps, as you.

The things we like are not the same: I romp, and race, and run,
And he lies down before the fire, or stretches in the sun;
But each of us would be forlorn without the other one.



THE SISTERS.

BY SHEILA GEORGE STERN.

THESE sisters, Jane and Marguerite,
Who are so friendly and so sweet,
Have just one doll for two;
One day she 's Janie's child they
play.

The next is Marguerite's day,—
A pleasant way to do.

When Jane's turn comes to have the treat,
She names the dolly Marguerite,
To please her sister dear;
And Marguerite says very plain,
"My dolly's pretty name is Jane."
When she is mother here,

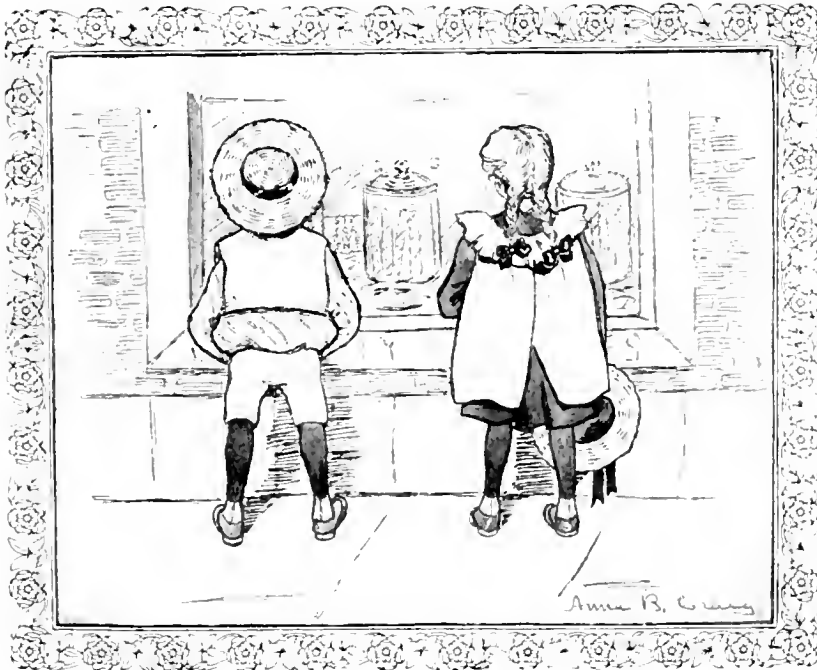

AT A CANDY-STORE WINDOW . . . MY DOLLAR, AFTER READING THE BILL, SAID: "SIX STICKS FOR FIVE CENTS—OH, WHAT LUCK! SIX STICKS FOR FIVE CENTS—FIVE FOR FIVE CENTS—FOUR FOR THREE CENTS—THREE FOR TWO CENTS—TWO FOR ONE CENT—ONE FOR NOTHING! I HAVE ONE CENT, I'LL GET TWO STICKS. YOU HAVE NO MONEY, SO YOU GET ONE FOR NOTHING. LET 'S GO IN!"

THE FRIEND WITH BRASS BUTTONS.

BY ISABEL GORDON CURTIS.

"Why, Chuckie Wuckie, what is the matter?" asked papa.

They were walking home one afternoon, when they met a squad of policemen marching two by two, and looking straight ahead.—tramp,



"SHE RAN AND HID BEHIND A TALL BUSH."

tramp, tramp, over the sidewalk. Chuckie Wuckie was holding her papa's hand when she saw the policemen. She gave a little scream and ran and hid behind a tall bush, with her hands over her eyes.

"Little goose!" whispered papa. "Don't

you know policemen are the best friends little girls have?"

"No, they are n't!" cried Chuckie Wuckie; "you ought to hear what Georgie says about them. A policeman is worser than any story-book ogre. When he sees a little girl he 'll chase her so she can't run straight. She 'll go running round and round and round, then she 'll get to spinning just like a top, and then the policeman will make a dive at her and bite her head off!"

"I 'll have to talk to Georgie," said papa, severely; "now we will go home."

The very next day, when Chuckie Wuckie and her papa went walking in the park, they saw something very interesting. A policeman lay on his face beside the duck-pond, and was pulling out of the water a little half-drowned puppy. The policeman dried it with his handkerchief, and rubbed it to make it warm.

"Now you see how good policemen are. Let us go and talk to him."

He knew the policeman,— his name was Mr. Britton; so he introduced Chuckie Wuckie to him. All at once the little girl forgot to be afraid; she got down on her knees to pet the little puppy.

"Whose little puppy is it?" she asked.

"I 'm afraid I can't tell," said Mr. Britton; "I think some bad boys threw it in the pond. They ran up the bank when I came in sight."

"Oh, papa!" cried Chuckie Wuckie. "can't I have it for my really own little doggie?"

Mr. Britton said he would be very glad to have them take the little puppy; then he told them about a stray kitty he once found in the park. He took it home to his little girl, and he had lots of stories to tell of how cunning it was.

"I 'll never, never be afraid of policemen any more," said Chuckie Wuckie, when she had shaken hands with Mr. Britton and said good-by.

"Of course you won't," said papa; "whenever

you see one of these big men in his blue clothes and brass buttons, remember he is your friend, and if you are lost or in any trouble go right straight to him."

It was a good thing Chuckie Wuckie remembered this, for just a few days after she had an adventure which might have been a pretty serious one. She was going to New York with papa and mama. They got into the depot just in time to see the "choo-choo cars" come roaring in. Her papa rushed to check a trunk, and left Chuckie Wuckie with mama. Then papa came back and jumped on the train; he thought mama had the little girl. Mama thought papa had taken her, and there she was left all alone in the middle of the big crowd. "Mama! papa!" cried Chuckie Wuckie, "where are you?"

Nobody answered. The big train went puffing out, and in a minute there was nobody left in the depot,—nobody but a few men who went hurrying about, and one big policeman in a blue coat with brass buttons.

Chuckie Wuckie walked straight up to him and put her hand into his; then she asked in a shaky little voice: "Will you take care of me, Mr. Policeman, till my papa and mama come back? The choo-choo cars carried them away!"

"Of course I will," said the big policeman; and he lifted her up in his strong arms.

He was a very jolly policeman. He had a great, big laugh, and he made it seem so funny about mama and papa being carried away without their little girl, that Chuckie Wuckie actually began to laugh instead of crying. He kept going to the telephone-booth every little while, and at last he set Chuckie Wuckie on the chair and told her to listen. She heard somebody cry, "Hello!" then there came a big, happy laugh. It was papa's laugh, and he said, "Is this our Chuckie Wuckie safe and sound?"

"Yes," answered the little girl; "where are you?"

"We're here at Hartford. We jumped off just as soon as the train stopped. Poor mama's half crazy."

"Tell her she need n't feel bad, papa. I've been having a lovely time with one of my best friends,—a beautiful, big policeman."

Then mama came and talked and half cried for a minute; then she laughed; then they said, "Good-by," because a train had arrived, and they were going to jump on it to come back after their little girl.



"OF COURSE I WILL," SAID THE BIG POLICEMAN, AND HE LIFTED HER UP IN HIS STRONG ARMS.

When they did come, Chuckie Wuckie was almost sorry to have to bid her policeman "Good-by"; only he promised to be at the depot, ready to say, "Hello!" when they came back from New York. And he was there, too!

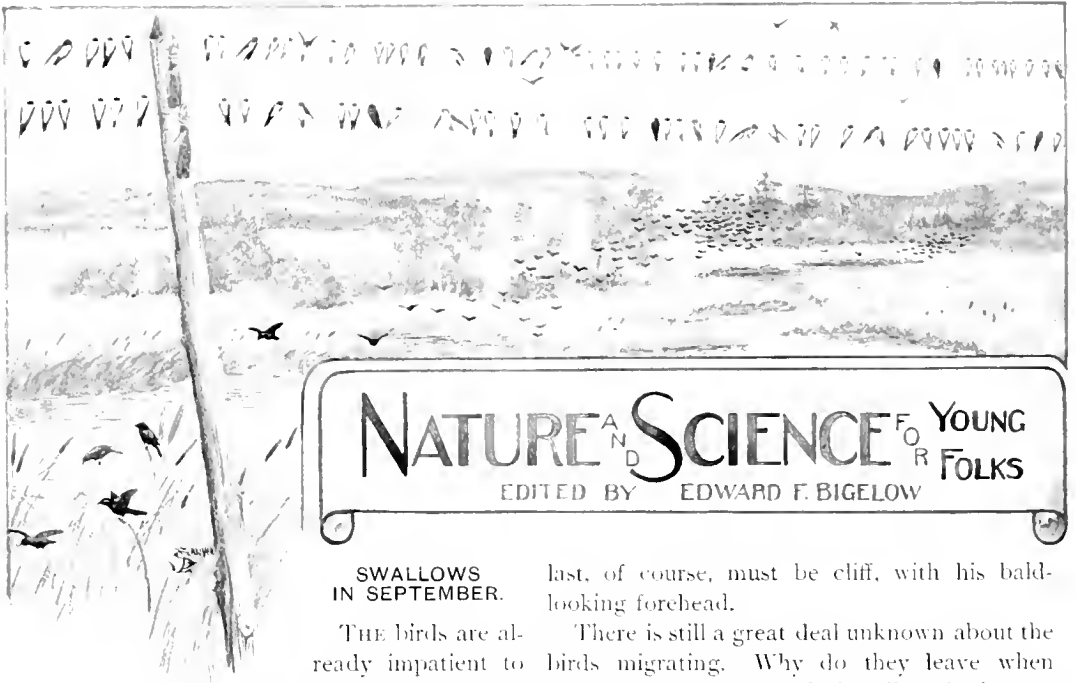

NATURE AND SCIENCE FOR YOUNG FOLKS

EDITED BY EDWARD F. BIGELOW

SWALLOWS IN SEPTEMBER.

THE birds are already impatient to be off, and have few songs, but mostly talk together in low tones, as if they are thinking of the long flight southward and discussing plans. There are the swallows who have alighted, so that the telegraph wires are covered for a block or more.

This is a good time to study the swallows, for they are all together now, each having left his summer home: the bank-swallow from the sandy cliff, the tree-swallow from some lonely hollow tree or fence-post or pile of lumber, the barn-swallow from his hayloft, the cave-swallow from the row of snug mud-nests beneath the barn's eaves. Now that we have them before us, all at once, let us compare them, sitting side by side upon the wires; then whenever we see one alone we shall know him at a glance. In some places there are yards of barn-swallows, then of tree-swallows, then of barns again. But here are four birds, all unlike and side by side. The first is plainly a barn-swallow, as we know by the tail and wings, which reach as far (or farther) on one side of the wire as his head does on the other; the next, so large and with such a white breast, can only be the tree-swallow; while the third is too small for anything but the bank; the

last, of course, must be cliff, with his bald-looking forehead.

There is still a great deal unknown about the birds migrating. Why do they leave when there is still food enough for all, and pleasant weather? What tells them, or how do they know, winter is coming—a season of cold and famine? What birds mingle and what journey by themselves? And how do they know their course? Perhaps some young person is to answer some of these questions by studying the swallows, who are nearly everywhere found and easily watched. Notice how the different kinds mingle, or sit apart on the wires, in some places singly, in some grouped.

EDMUND J. SAWYER.



FOUR VARIETIES OF SWALLOWS

Barn. Tree Bank Cliff, or Cave.

(See letter, comment, and illustrations in "Distinguishing the Swallows," Nature and Science for September, 1903, page 1037.)

A FOUR-FOOTED HARVESTER.

You who have traveled in the mountains of the West will remember seeing great piles of broken rock resting in the gullies or at the base of cliffs, like ice-cakes in a gorge.

In these rock gorges throughout the high Sierras, Rocky Mountains, and their spurs, lives a short-legged, thick-set little alpine farmer only seven inches long. He has several aliases: Cony, Rocky Mountain Pika, McGinnis Rabbit, and Little Chief Hare. His color varies from yellowish brown to dark gray, according to the species. If he had bunnies' ears you would call him a miniature rabbit, for in many ways he resembles one, not only in looks but in structure as well. He has a similar set of upper incisors back of the regular ones, and his tail is as short in proportion as that of a rabbit. His fur is so thick and soft that every puff of wind parts it or leaves chrysanthemum-shaped spots, to be obliterated or made anew by the next gust. Unlike the marmots and chipmunks that share his rocky

of the day or night, regardless of the season. From an elevation usually above eight thousand



STACKED FOR THE SUN TO CURE.
(Photograph by E. R. Warren.)



WATCHING THE SUN RISE.
(Photograph by E. R. Warren.)

feet, he mounts a boulder and watches the sun rise.

Along the streams at the base of the mountains is a thick growth of fireweed, purple aster, alpine spiraea, and buck-brush. These plants form a principal part of the cony's food, and he seems to realize that, unless he makes some provision, the winter months are sure to bring starvation, so he "makes hay while the sun shines." He does not wait until the foliage has shriveled on the stalk and lost its nourishment, but he cuts it green and, gathering it in little bundles, takes it between his teeth and hurries back to the rocks. He presents a comical sight as he bounds silently toward you, the hay protruding from the sides of his mouth, apparently blinding him, and you wonder that he dares to run so fast. Instinct has told him that, if taken into the crevices of the rock, green hay will mold, so he stacks it in the open air for the sun to cure, in several neat haycocks, varying in size from a water-bucket to a beehive.

J. ALDEN LORING,
(Six years a Field Naturalist to the
U. S. Biological Survey.)

retreats, he does not spend the winter hibernating, for you may see or hear him at all times

PUMPING OIL OUT OF THE OCEAN.

As the tourist on the train rushing north to Santa Barbara nears the famous mission city, he sweeps by a large group of oil-derricks situated right out in the Pacific Ocean itself. "Yes," the trainman hurriedly replies to his eager inquiry, "they're pumping oil out of the ocean!"

I was fortunate enough to meet the proprietor of these very oil-wells, after a similar ex-

perience with a trainman, and from him I gathered just the information I wanted.

end of these wharves oil is found at a depth of two hundred and seventy-five feet, while at the far end of the ten-hundred-foot wharves, where there is thirty feet of water, a depth of five hundred and twenty-five feet has to be reached. The stratum containing the oil-sand declines at a very much greater angle than the bed of the ocean. The oil-sand, in which oil is found, projects out into the Pacific at this point only.

MEREDITH NUGENT.



DERRICKS FOR PUMPING OIL FROM THE OIL-SAND FAR BELOW THE WATER NEAR SANTA BARBARA.

perience with a trainman, and from him I gathered just the information I wanted.

Of course the oil is not actually pumped out of the ocean, but from the oil-sand far below the bed of the ocean. A number of wharves from six hundred to ten hundred feet in length have been built in the water, and on top of these the oil-derricks are raised. At the shore

I inquired of the proprietors of these oil-wells how they first knew that there was oil under the water in that particular place. Their reply was:

"Oil broke through the overlying strata in several places along the beach. There is also a sunken reef, seven miles from shore, from which the oil was oozing, showing that the oil formation underlay the sea bottom."—EDITOR.

THE RED-WINGED SEA-ROBIN.

I SUPPOSE the peculiarity which would be noticed first about the sea-robin, grunter, or gurnard, as he is variously called, would be his clumsy shape. The head is large and deep in comparison with the body. One of our observing young folks, looking at him alive in his tank of the United States Fish Commission, Washington, would be apt to exclaim, "Oh, see, he has little hook-claws which help him crawl along!" Sure enough, just in front of the pectoral or side fins are three little, finger-like processes on each side, which are used to stir up weeds and sand, and to rake around among the pebbles and rout out the small animals upon which the sea-robin feeds in its native waters. While doing this it seems to be crawling along over the bottom by hooking these peculiar claws into the sand. Sea-robins feed on small crabs, fish, shrimps, and other diminutive animals, which they find in among the loose stones. In Europe all the gurnard family of fishes are eagerly sought, as they find a ready sale in the fish-market. They attain a length of two feet and a weight

of eleven pounds. Our species of the sea-robin, a cousin to the European variety, is found on our northern coast, and is taken in great numbers in the pound-nets along Vineyard Sound, where they spawn during the summer months.

They are much esteemed for the table, being one of the most delicate of the edible fishes. The flesh is firm, snow-white, and hard to distinguish from that of the kingfish. The American sea-robin is fifteen to eighteen inches long and weighs from one and one fourth to two pounds. When taken from the water they grunt

quite loudly, and if placed on the ground give a little hop forward of a few inches, grunting as they do so. This grunting sound can be heard quite plainly if one is in a boat lying quietly in shallow water near where they are.

The head is sheathed with bony plates and armed with sharp points, which are rather hard to distinguish at first, as they lie quite flat against it. When caught they erect all their spines and inflict very painful wounds on those who try to handle them. The pectoral fins are a little more than half as long as the body, and may be extended like a fan when in use, or folded quite close together when on the bottom, thus giving them the name of "butterfly fish."

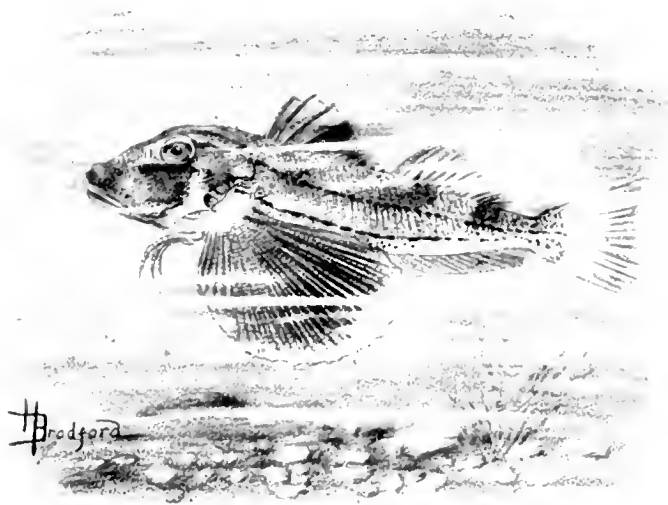

THE RED-WINGED SEA-ROBIN.

The "hook-claws" are placed quite close to the body when the fish moves very fast, and are thus hidden by the large pectoral fin. But when near the ground they are extended in anticipation of clutching the sand or stony bottom. The artist has represented the fish quite near the bottom, in which case the claws are as shown in the drawing.

The rays of the tail may also be much extended to look like a Japanese fan.

The color of this peculiar fish is a brownish yellow over the back and sides and cream-white below. The pectoral fins are deep orange-color with a blackish marking toward the tips, crossed all over with little dark brown lines and edged with light yellow-orange color. The lower jaw and sides are light orange-yellow; the eye is a beautiful turquoise-blue, edged with a vein of brassy yellow.

HARRY B. BRADFORD.

THE MUSSEL'S MUSCLE, AND HOW HE USES IT.

How is it that a mussel can close its shell so forcibly? The muscles are two in number, one in each end of the shell. They extend

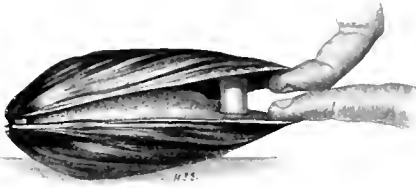

THE TWO MUSCLES OF THE MUSSEL.

Pulling against the fingers which are trying to separate the shell straight across from one valve to the other. Thus the fibers act at no disadvantage. The muscles in the arm of a man are arranged at great disadvantage, power being sacrificed for amount and rapidity of motion.

You must, sometime, try to open the shell of a fresh-water mussel or a sea-clam. You will find one the size of your hand has great strength, although both his muscles may not be larger than those of one of your fingers. I have often seen a boy pick up a mussel and insert his fingers before the shell was quite closed, thinking he could open it again. Few boys can succeed. They usually have hard pulling to get their fingers free. A big mussel can bite hard. Were it not that the edge of the shell, in big specimens, is smooth and thick, a boy might get his fingers cut to the bone.



SHOWING THE MUSCLES (M^1 AND M^2) CUT ACROSS.
The shell now opens out easily.

One who knows how can open the shell. I will tell you. Insert your fingers and pull steadily, not trying to open it at once, but simply

to keep it from closing. The mussel's muscles will soon get tired, and then you can open out the shell without difficulty.

You have one muscle to extend your arm and one to bend it. You have two muscles to open your mouth and six to close it. The mussel, being inside of the shell, cannot open it by means of a muscle; but his two valves are joined by a great ligament so arranged that it will hold the shell open all the time. The shell is open unless the two big muscles are acting.

C. A. HARGRAVE.

POCKETS IN THE CHEEKS.

CHIPMUNKS, squirrels, and ground-squirrels take food in their mouths and with their tongues push it out between the teeth into an elastic pouch (connecting with the mouth), thus extending the cheeks.

The pocket-gophers have pock-



A POCKET-GOPHER.

ets outside the mouth along the front of the cheeks. These pockets extend back under the skin to the shoulders, and are filled and emptied by the aid of the fore feet and claws. They are often stuffed so full of pieces of roots, stems, and leaves as to give a very ludicrous appearance to the little animal. Roots and stems are cut into pieces about an inch long and packed lengthwise. Leaves are folded or rolled to fill the smallest space.

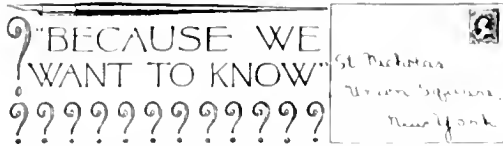

HUMMING-BIRDS CUT INTO FLOWERS FOR NECTAR.

MIAMI DA, CAL.

DEAR ST. NICHOLAS: We have a morning-glory vine in our yard, and after the flowers have bloomed they fall to the ground. I like to make them pop, but I have noticed that nearly all of them have a little hole in the side, near the end. One day, as I was swinging



RUBY-THROATED HUMMING-BIRDS.

in the hammock underneath the vine, I saw a little humming-bird. He wanted to get the honey that was in the flower, but his tongue was not long enough, so he made a little hole in the side, through which he got the honey. After that I watched a great many, and found that they all did the same thing.

Your interested reader, HELEN FENKE (age 10).

This is so unusual an observation that I sent copies of it to several prominent ornithologists in all parts of the country. I quote from three:

1. Berkeley, California: I cannot positively recall whether I have seen humming-birds pierce the side of a flower for food, or have merely heard of their doing so. At any rate, it is so clearly fixed in my mind that this is not an unusual habit, that I should not be inclined to question the correctness of the observation.

2. New York: I cannot throw any light on the statements of your California correspondent. Possibly the humming-birds fed through openings which had already been made by bees.

3. Bethel, Maine: I cannot help thinking that there must have been some mistake about the inclosed observation. The statement that "they all did the same thing" indicates this. It would be possible for an individual humming-bird to develop such a habit, but it seems to me most improbable that it can have become general to the species and yet not have been noticed before. I wonder if any of the hawk-moths puncture flowers in this way! As you know, they are often mistaken for humming-birds.

When three of the best ornithologists disagree, our young folks must settle the question by careful seeing.

MOSS ON THE NORTH SIDE OF TREES.

SOUTH ORANGE, N. J.

DEAR ST. NICHOLAS: I read the ST. NICHOLAS every month, and I love the Nature and Science Department very much. The other day, as I was walking in the woods with a friend, he told me that on most trees the moss grows on the north side of the trunk, and I looked and saw that what he told me was true. Would you please tell me why it grows on the north side and not so much on the other sides?

Your faithful reader,

LAWRENCE E. B. VAN VECHTEN (age 14).

Moss thrives best in cool, damp places. These conditions prevail most on the northern parts of trees, where the sun does not shine.

"POSITIVE NEGATIVES"

TOURS, FRANCE.

DEAR ST. NICHOLAS: Under the heading of Science, I would like to ask you why films and plates are sometimes positive instead of negative. The accident is not rare, I think. Recently, in a pack of twelve, I found one film in which shadows, trees, and sky were nearly black, while a white house and spots of sunshine were white. When printed, of course everything was the wrong shade.

Your interested reader,

ARNOLD W. KNATHL.

This is a frequent inquiry from our young photographers. In brief, and as simply as possible, it may be explained that "positive negatives" are produced by too much light and chemical action.

For those desiring more detailed, technical explanation, the following from the Kodak Correspondence School is given:

In a gelatino-bromide plate, the gelatine acts as the sensitizer. When the plate is exposed to light the gelatine absorbs the bromine liberated by the light from the silver bromide, forming complex silver bromine compounds, until a point is reached when, with the aid of the oxygen of the air and of moisture and further action of light, a reversal takes place, and the silver reduction product is re-brominated to form silver bromide,—this, when developed, giving a positive in place of a negative.

A MIRAGE.

PARIS, FRANCE.

DEAR ST. NICHOLAS: One day several years ago I saw a very strange thing. It was a ship upside down in the sky. It was very interesting. I am very interested in Nature and Science.

Yours truly,

THOMAS P. MILLER (age 16).

Not long after I received this letter I was riding in a fast express-train across the sandy plains of New Mexico, where the only vegetation was a few low scattered shrubs and some

than on those muddy banks by that small river a few miles back."

He smiled. He had been over the road half a dozen times, he told me, while this was my first trip.

"Try your field-glass," he merely remarked.

I did; and, like a beautiful dream that is lost on waking, the lake disappeared when viewed only through the glass. Later, as the train came nearer, I saw that it was only sand and scattered shrubs and grass. It was a desert mirage, and I was as much astonished

as was the writer of the above letter when he saw the ship "upside down." A traveler in an Egyptian desert writes:

A mirage usually takes the form of water; and the illusion is so complete that I have stood and talked to a man who apparently was standing up to his knees in a lake, the ripples of which broke on the sand a few yards from me. The most curious series of mirages



A MIRAGE IN A DESERT.

tufts of coarse grass. In the distance I saw, to my great surprise, a beautiful lake extending out of sight in the haze of the sky and distant mountains. On the nearer parts of the lake there were beautiful islands with trees and shrubs, some of them apparently extending downward as if reflected in the water. I thought what a beautiful place that is, and I remarked to a fellow-passenger: "Strange that there should be such a beautiful lake in this desert. Would n't it be nice to take a boat and row around among those islands? Perhaps there may be interesting water-birds that have nests among those tall grasses and shrubs. It seems to be a better home for the pelicans

I have witnessed, however, occurred when leaving my Atab friends and returning to the Delta.

We had ridden for nearly four hours, and still seemed as far from Tanis as ever, the mounds appearing just as distant as at the start, when suddenly a curious "twinkle" of light and landscape occurred, most bewildering to the senses, and before I was able to rub my eyes clear we were standing on the mounds themselves! Crossing the Bahr Fakous, a deep canal crossed by a ferry, similar phenomena were repeated. Looking westward toward the sun, the plain appeared to be one huge inland lake, bordered by palm-groves and villages. While debating the subject, I noticed that several of my companions had disappeared, and with them all signs of the mounds. A few moments later I saw them all upside down in the sky, while the riders, on approaching more closely, suddenly righted themselves and stood upon terra firma once more.

LITTLE FLIES FROM EGGS OF BUTTERFLIES OR MOTHS.

FRESH FIELDS, GREENS FARMS, CONN.

DEAR ST. NICHOLAS: I am very much interested in your Nature and Science department, as I have watched the complete change from egg to imago in butterflies and moths, and am very fond of such things. One thing struck me as very queer the other day, and I thought I would write to you about it. I found two eggs of one of the big moths and put them in a glass jar. One hatched, but the other lingered a long while, and when it did hatch, my surprise was great. Five little flies, no bigger than a large type period, came out! Think of it! I have had them come out of caterpillars. But eggs! Did you ever hear of such a thing? Please tell me about it, "because I want to know."

PHILIP SIDNEY SMITH.

It is no uncommon thing for insect eggs to be parasitized as described by you. I would sooner suspect it of a butterfly's egg than of that of a moth, from which the five little parasitic flies emerged. The eggs of the larger moths are not often thus parasitized, but from some butterflies' eggs as many as a dozen little parasites have been reared. I could not guess what egg it was you had. I raised four of these minute parasites from a coddling-moth's egg, which is no larger than a pin's head!

M. V. S.

ROARING SOUND IN LARGE SHELLS
BALTIMORE, MD.

DEAR ST. NICHOLAS: I have often wondered what is the answer to the question I am going to ask you. What makes that sound in large shells? When you put them to your ear they sing. People say that it is the sound of the waves. If you can answer this I will be very glad.

Your loving reader,

MARGARET B. WOOD.

This roaring of large spiral-shaped shells may impress upon us how constantly the air is in motion and how it is thrown into gurgling eddies by various bodies of the same or similar shape. Its faint rustling is intensified by such *resonators*, just as the buzzing of a fly becomes louder as he approaches the mouth of a bottle. Boxes, large-mouthed bottles, or even the hollow of your hand (with fingers nearly closed), if held near the ear, produces some of the "roaring sound."

ROCK-OYSTERS.

NYEBROOK, YAQUINA BAY, OREGON.

DEAR ST. NICHOLAS: One morning very early, when the tide was far out beyond the reefs, we went down on the beach. Several Indians, some with picks, others with hammers and wedges, were digging rock-oysters, of which they are very fond. Tourists also like the novelty of knocking the rocks to pieces, and some really enjoy eating the rock-oysters. The photograph is of a number of these pleasure-seekers, and was taken by A. L. Thomas of Nyebrook.

The scientific name of the rock-oyster is *Pholis*. They are really a variety of clam, and are cousins to those that live in the mud.

When the *Pholis* is first hatched it is very small. It swims about in the water for several days, until its shell begins to grow. Then it fastens upon a rock, and at once begins wriggling and working to make a hole in the rock. The rasp on its shell aids it, and this rasp and the sand that is washed between it and the rock are the only tools the *Pholis* uses. It makes little or no difference whether the rock is soft or hard, except that it takes longer to work in the hard rock. Even when the *Pholis* has made a hole large enough to rest in, it does not stop its work, but the larger it grows



DIGGING FOR OYSTERS.

the larger it makes its home. The entrance it made into this home is small, and now that the *Pholis* is full-grown it can never get out. The sand shifts in to a certain degree, but there is always an opening. The *Pholis* has a long neck or tube which it reaches out through this entrance into the water, and through which it receives its food.

AGNES DOROTHY CAMPBELL (age 14).

The August Nature and Science contained an interesting article on these remarkable shell-fish.

ST. NICHOLAS LEAGUE.



"A HEADING FOR SEPTEMBER." BY JOHN D. BUTLER, AGE 15. (GOLD BADGE.)

A SONG FOR THE BELATED.

IF the ladder you would climb,
Be on time;
Picture, puzzle, prose, or rhyme,
Be on time.
Hours and moments will not stay,
Better be ahead a day,
Don't forget and don't delay—
Be on time.

In the May number we gave notice in two places that the August competition would close five days earlier than usual and the September competition five days later. Nevertheless, there were, as usual, a number of contributors who waited not only until the last day of the given closing time before sending in their work, but until three or four days later.

Now, the examination of the League contributions is a very big work, and the date when the magazine goes to the printer is not a thing to be changed. It is no use saying, "My contribution this month is a little late, but please consider it, anyway," for such a request is just about as hard to grant as to hold a train for a dilatory passenger who is running, red-faced and breathless, three blocks away.

The proper thing to do is to be on time. When the statement is made in the League pages that a competition closes on the 15th, or the 20th, or the 25th, it means that on five o'clock of the given day the entry-books for that month close, and that no more contributions are to be considered. Because the magazine does not appear until two months later does not mean that we have all that time to get it ready. We have very little, in fact, for on a magazine like *ST. NICHOLAS* the presses begin on some of the first pages even before the League competition closes, and it sometimes happens that the League editor has to work night and day to get his department ready so that those hungry

presses may not be kept waiting. It is for this reason that he has written the above little refrain, which may, perhaps, stick in some dilatory member's mind and make him more prompt next time. And, after all, promptness is one of the greatest things in the world. All through life it means a saving of annoyance—it *may* mean just the difference between failure and success.

PRIZE-WINNERS, COMPETITION No. 69.

In making the awards, contributors' ages are considered.

Verse. Gold badges, **Clarence E. Spraul** (age 16), 1108 Dayton St., Cincinnati, O., and **Phyllis Sargent** (age 11), Graeme's Dyke, Berkhamstead, Eng.

Silver badges, **Margaret Spencer-Smith** (age 15), 51 Palace St., Westminster, London, Eng., and **Louise Grant** (age 12), 110 Merriman St., Akron, O.

Prose. Gold badge, **Frances W. Varrell** (age 13), 6 Richards Ave., Portsmouth, N. H.

Silver badges, **Buford Brice** (age 11), 1404 Bacon St., N. W., Washington, D. C., and **Constance C. Coolidge** (age 13), Somerset Hotel, Boston, Mass.

Drawing. Gold badges, **J. Frances Mitchell** (age 17), 1304 Buchanan St., Topeka, Kan., and **John D. Butler** (age 15), 628 12th Ave., N. Seattle, Wash.

Silver badges, **Dora Grey** (age 11), Fulford Vicarage, York, Eng., and **Gladys Moore** (age 17), Chatham, New Jersey.

Photography. Cash Prize, **Irene Mersereau** (age 17), 99 N. Marengo Ave., Pasadena, Cal.

Gold badge, **Harold Fowler Gerrard** (age 17), Kenilworth Road, Euclid Heights, Cleveland, O.

Silver badges, **Launcelot J. Gamble** (age 13), Palo Alto, Cal., and **Houston Woodward** (age 9), Chestnut Hill, Philadelphia, Pa.

Wild Animal and Bird Photography. First prize, "Alligator," by **Joyce Slocum** (age 14), Flint, Mich. Second prize, "Blue Herons' Nests," by **Edwin Begel**

(age 15), 1107 S. 8th St., Manitowish, Wis. Third prize, "Wild Ducks," by **Allen Potter** (age 9), 10 Braintree Rd., Boston, Mass.

Puzzle-making. Gold badges, **Tessie Tag** (age 15), 1185 W. Adams St., Los Angeles, Cal., and **W. S. Maulsby** (age 14), Box 90, Tufts College, Mass.

Silver badges, **Elizabeth H. Crittenden** (age 15), 319 11th Ave., Belmar, N. J., and **Reginald A. Utley** (age 15), 112 Gerrard St. E., Toronto, Canada.

Puzzle-answers. Gold badge, **Mary Elizabeth Askew** (age 15), 1024 Lexington Ave., Altoona, Pa.

Silver badges, **Joseph S. G. Bolton** (age 11), 59 Division St., New Haven, Conn.; **Margaret E. Nash** (age 12), 525 Summer St., Rockford, Ill.; and **Laetitia Viole** (age 14), 206 Porter Ave., Buffalo, N. Y.

WHEN SUMMER IS OVER.

BY THYLIS SARGENT (AGE 11).

(*Gold Badge.*)

When summer is over, I sit at the window
And gaze in the twilight across the dim sea,
And watch the last swallows that fly to the
southward,
Away o'er the ocean from winter and me;
And breezes of evening come in through the
casement,
And bear me the breath of the far-off salt
sea.

When summer is over, and hid are the sun-
beams,
And gray clouds have covered the rose-tinted
west,
There comes from the meadows, the green,
dewy meadows,
A soft, drowsy murmur, when all sinks to
rest;
And then there is silence, for nature is sleep-
ing
Deep down in the valley and on the hill
crest.

When summer is over, and reaped are the corn-
fields,
And home has been driven the last creaking
wain,
And the fruit has been picked from the apple-
tree's branches,
And the leaves are all changing in woodland
and lane,
I think of the beauty this summer has brought us,
And the beauty next summer will bring us again.

A STRANGE ADVENTURE.

BY FRANCES W. VARELL (AGE 13).

(*Gold Badge.*)

SEVEN years have passed away since my strange ad-
venture; it seems a long time ago, for the incident
occurred when I was only six years old, but my memory
recalls most vividly the scene, which I shall never forget.

It was at Portsmouth, New Hampshire, during the
memorable month of July, in the historic year of 1808,
and following the great battle of Santiago within a very
few days. More beautiful days never dawned upon the
rugged New England coast than those which ushered in
the disembarking of the Spanish prisoners of war—the
survivors of Cervera's fleet—prior to their imprisonment
in a huge stockade.

An urgent message from my father, who was station-
ed at the Portsmouth Navy Yard, saying the Com-
mandant had granted my mother and me privilege to wit-
ness the landing of prisoners, brought us hurriedly to
the scene. Upon our arrival we found hundreds of
marines with loaded rifles and fixed saber-bayonets
awaiting the mournful procession. Then commenced
the most strange and unhappy scene of my life; hun-
dreds of half-clothed, barefooted men and boys, some
with but a sheet or blanket wrapped about them, just
as they had manned Cervera's guns and faced the Ameri-
can fleet one week before, filed up the steep hillside—
living pictures of despair and death, for they thought
they were going to be shot by the cordon of marines



"NEVADA FALLS" (YOSEMITE). BY IRENE MERSELAU (AGE 17).
(CASH PRIZE.)

who stood grimly by. Many of these Spanish heroes
worked for weeks in the trenches before tropical Santi-
ago, and were terribly debilitated by fevers and the
dreadful experience of the battle. Some came stag-
gering under the burden of a weaker comrade, and others
were assisted by a friend on either side.

All about, the cries of "Aqua!" "aqua!" or water!
water! could be heard, and dozens of the poor creatures
fell fainting and insensible on the lawn. We got water
from the little well by the road-side, and gave it to them.
Some of them were so grateful that they tore buttons
from their uniforms in an attempt to repay the favor.
I saw but one officer at the first landing of the prisoners,
a very large, severe, and forbidding man. He was in
irons—it was said because he attempted to incite
mutiny.

In the first ten days sixteen died, and when the survi-
vors sailed for their beloved Spain, thirty-one were left
behind in the little cemetery by the sea.



"NIAGARA BEFORE A STORM," BY HAROLD FOWLER GERRARD, AGE 17. (GOLD BADGE.)

A SUMMER'S NIGHT IN THE LAND OF DREAM.

BY MARGARET SPENCER-SMITH (AGE 15).
(*Silver Badge.*)

WHEN gentle Night her purpling robe o'er all,
The throbbing, heated city softly draws,
When cooling winds fan out the sultry air,
And the Dream-angel smiles from
Heaven above;
Then, when the white sleep-portals
open wide,
And the great world slips far away
beyond,
Before closed eyes the half-lit
pathway lies,
And Dusk stands beckoning to
the Land of Dream.
Beside the way tall, nodding poppies
grow,
Loading the air with drowsy,
scented breath,
And wearied crowds seek there
forgetfulness—
But on the mountain-side the air
blows free,
And slender fawns slip through
the silvered path;
Dew diamonds hang on every
shaking leaf,
And spiders' webs shine silver in
the way.
Among the lichen, on a rotted
stump,
The glow-worms shine, the lamps
that light the way;
Till, stealing through the hush
of scented pines,
The ridge is reached, and stretching
down below,
Lies, wrapt in mist, the Wonder-
ful Beyond.



"UPPER YOSEMITE FALLS," BY LAUNCELOT J. GAMBLE, AGE 13. (SILVER BADGE.)

SUMMER.

(*A Sonnet.*)

BY CLARENCE E. SPRAUL (AGE 16).
(*Gold Badge.*)

THOU' comest, summer, ushered in by spring,
With flowery pennants sweet with spring's
last glow,
To the music of the murmuring brooklet's flow,
The singing birds join in thy welcoming,
The woods reccho with the glad notes' ring;
While o'er the fields and gardens float the low,
Soft sounds of June. Warm breezes gently
blow
And breathe their perfumed breath on every-
thing,
Thou, summer, happy in thy mantle green,
In smiling roses and narcissus bright,
Thou seem'st the sweetest time of all the year;
For thou art nature at her best, I ween;
With nature's gayest clothes thou art bedight,
In thee her brightest glories all appear!

A STRANGE ADVENTURE.

(*A True Story.*)

BY LOIS F. LOVEJOY (AGE 14).

A MILITARY funeral procession was moving up
Hull Street, in Old Boston, from the Old North
Church to Copp's Hill burying-ground. The band
went first, then came the soldiers.

It had been raining that morning, and they wore their
waterproof capes, and so presented a very peculiar ap-
pearance.

Following them came the funeral train, with the flower-
decked and flag-draped coffin.

All these rather unusual sights and sounds attracted
the attention of a little girl, about eight years old, who was
playing near by. With a child's natural curiosity she followed
the procession to the cemetery, and there, from a little distance,
watched the proceedings in front of the large brick receiving-
vault until the funeral was over and all the soldiers had gone
away.

The little girl, wishing to see
more, advanced to the door,
which had not yet been locked,
and peered in.

Oh! what lovely, lovely flow-
ers they were! She took a
step nearer, and then, forgetting
everything else, boldly stepped
in and began admiring first one
lovely blossom and then another.
Suddenly, and without any warn-
ing, the place grew dark, there
was a dull thud, and the sound
of a key grating in the lock. The
sexton had come and locked the
door without seeing her!

The child rushed to where
the light from the keyhole told
her the door was, and began to
bang, and kick, and scream with
all her might.

Would no one hear her? It
seemed ages before she heard

steps on the outside and the key again turning in the lock.

In a minute the door was opened, and rushing out, she almost pushed the old sexton over in her hurry to get away.

Not waiting to explain, she dashed down the path and away home as fast as she could go, leaving the old man, watching her with wondering eyes, at the door of the tomb.

A SUMMER RAMBLE.

BY LOUISE GRANT (AGE 12).

(Silver Badge.)

I WANDERED through the valley,
I lingered by the brook,
And read of birds and flowers
From Nature's story-book.

I sauntered in the woodland,
Cooled by the gentle breeze,
And drank from a tiny crystal spring,
That bubbled 'neath the trees.

I plucked the timid flowers,
That grew hard by the stream,
And lay among the grasses,
About the world to dream.

But as I went a-sauntering,
My only thought could be,
That all these countless beauties
Were made for you and me.

A STRANGE ADVENTURE.

BY CONSTANCE C. COOLIDGE (AGE 13).

(Silver Badge.)

I AM a big fat mouse, and my name is Longtail.

My wife, my two children, and myself used to live in a very comfortable part of a house, but our neighbors were so fond of meddling in our affairs, and giving un-called-for advice, that we were forced, much against our will, to leave. We found, at last, a small house, with what looked like a tree growing out of the side of it; in this we made our home. One day when we were all talking quietly together, we were startled by feeling ourselves, house and all, being lifted up—up.

My wife in her terror nearly fell off into space, and it was with the greatest difficulty that I managed to grab her in time. Suddenly in front of me I saw a mirror; in it I saw my house, my family, and, in fact, all I had, perched on top of an old lady's head. (This old lady inhabited the house all by herself, although she had many poor relations



"SOUTH CHEVENSSE FALLS." BY HOUSTON WOODWARD, AGE 9.
(SILVER BADGE.)

who worked hard for their living, and even then scraped barely enough together to get along with.)

You can imagine how astonished I was. I gasped for breath, pinched myself, but found I was not dreaming, as I had at first supposed. Then we began to move; downstairs and out of doors we went. My children were delighted, and gave little squeaks of excitement; as to my wife and myself, we were far too astonished for utterance. Our lady first went to her dressmaker to leave an order, and then on to see a friend. At last we saw the great wide world. Horses and carriages

streamed past us. People in all stations of life hurried by on foot, most of them looking bright and cheerful in harmony with the lovely morning. The first thing the old lady's friend said when she saw her was: "Why, Jane, what under the sun have you got on your hat?" With great alacrity she took off her hat. We all jumped just in time, raced across the floor, and landed in a hole conveniently near. The hole made a very comfortable house for us, and we are living in it now.

As to the old lady, when she saw us she gave one piercing shriek and—but we waited to hear no more.



"A STUDY OF FLOWERS." BY DORA GREY, AGE 11.
(SILVER BADGE.)

The St. Nicholas League is an organization of the readers of the ST. NICHOLAS Magazine. Instruction leaflet and League badge will be sent on application.

SUMMER.

BY ISADORE DOUGLAS (AGE 17).

(Honor Member.)

GLORY of sunshine on far-away uplands,

Fields daisy-powdered and white near at hand,
 Dragon-flies dancing where placid brooks ripple,
 For summer's warm fingers are laid on the land.

Butterflies flitting from milkweed to thistle,
 Swamps deep with lush-grass where wild lilies sway;
 And clear from the stubble a quail's plaintive whistle
 Comes up with the fragrance of freshly mown hay.



"ALLIGATOR." BY JOYCE SLOCUM, AGE 14. (FIRST PRIZE,
 "WILD-ANIMAL PHOTOGRAPH.")

SUMMER.

BY RUTH LABUNZEL (AGE 7).

SAILING on the river,
 Running on the land,

Bathing in the ocean,
 Playing in the sand.

A STRANGE ADVENTURE.

(A True Story.)

BY BUFORD BRICE (AGE 11).

(Silver Badge.)

My uncle, who is now a major in the Marine Corps, a few years ago had command of a battalion of marines in the march on Peking, to rescue the Americans at the time of the trouble with China.

As they neared the wall of Peking, after a long and tiresome march, my uncle noticed a small-sized river between them and the wall, on which were hundreds of Peking ducks.

My uncle, thinking one would taste very nice after the fare he had been having, stooped to catch one that was near the shore.

The wall was covered with Chinamen who were firing at the soldiers. One of them evidently noticed my uncle was one of the officers, and fired at him.

Just as my relative stooped to hit the duck, the bullet

went whizzing by above his head, but just where his head would have been if he had not stooped.

He succeeded in getting the duck, which he took with him into Peking, expecting to have a feast; but hearing that Mrs. Conger had been kept a prisoner in the Legation so long that her food had given out, he sent her the Peking duck that had saved his life.

SUMMER EVENING ON NARRAGANSETT BAY.

BY CAROLINE MILLARD MORION (AGE 17).

(Honor Member.)

THE tide has ebbed; her dark blue veil
 Slips down before the face of day;
 But through the meshes, here and there,
 There shines a glint of golden hair.
 The moon drips on the quiet bay
 Soft rings of witch-fire pale.

The little waves wash to and fro,
 With endless murmurs to the beach—
 The sand gleams cool and hard and white
 Beneath the moon's reflected light—
 They stretch their little hands to reach
 The great rocks lying low.

The salt sea-breeze brings in a sound
 Of music, from the city caught;
 Across the rippled stretch of dark
 Gleams now and then a moving spark.
 The peace that passeth all our thought
 Is settled close around.

A STRANGE ADVENTURE.

BY ESTHER FLORENCE AIRD (AGE 13).

"THERE!" cried Madge, angrily, "I've forgotten to bring home my paint-box from the Art Gallery! I suppose I'll have to go and get it. I hope it will stay light a little longer."



"BLUE HERONS' NESTS." BY EDWIN BEGEL, AGE 15. (SECOND PRIZE, "WILD-BIRD PHOTOGRAPH.")



"A HEADING FOR SEPTEMBER." BY J. FRANCIS MITCHELL, AGE 17. (GOLD BADGE.)

Without saying anything to her parents, she put on her coat and hat, and slipping out at the side door, ran quickly along the crowded streets to the Art Gallery, and up the long staircase to the room where she worked. To open her drawer and get out her paint-box was but the work of a moment.

The rooms were all deserted, and Madge, who was now in no hurry, strolled into the studio of an artist, a friend of her father's. Easels and pictures were crowded all around her; and quite oblivious to the time, she wandered about in the twilight, feasting her eyes on the canvases.

Suddenly, however, she came back to earth, and realizing that the night was coming on, she quickly traced her way to the door of the studio. The door was locked!

At first Madge thought she had made a mistake, and pushed and shook the door; but all in vain.

Then the terrible truth flashed upon her. The artist was leaving town this evening for a week, and the janitor had locked the door, which would not be opened until the gentleman returned. The Art Gallery was in a very old house with thick walls and doors, and this room was on the top story, so call as she might she could not be heard.

Around her the canvases loomed high, dim, terrible shadows in the dark room, lighted only by the misty moon without. Madge, though not a timid girl, cowered in a corner, hiding her face in affright when one ghostly figure seemed to be moving in its picture.

For many hours (or so it seemed to her) she lay there shivering in the great barn of a studio, surrounded by awful shadows that seemed to tower over her.

Just when she felt she could bear it no longer, the key turned grumblingly in the lock, and the artist entered, the moonlight striking full on his face.

"Oh, Mr. Harvey!" cried Madge, springing forward; "I'm so glad you've come! I was terribly frightened, and—"

The old artist, who had missed his train, quieted Madge, and then took her home through the deserted streets.

A SUMMER SONG.

BY LEWIS S. COMBES (AGE 8).

(Honor Member.)

SING a song of summer,

Barefoot days are fun;

Sing a song of summer,
Dancing in the sun.

Sing a song of summer,
Roses by the door;

Sing a song of summer,
Buds and blossoms more.

Sing a song of summer,
Wading in the brook;

Sing a song of summer,
Fishing with a hook.

Sing a song of summer,
Fireflies at night

Sing a song of summer,
Sparkling in their flight.

Sing a song of summer,
Playing time is done;

Sing a song of summer,
School days have begun.

A STRANGE ADVENTURE.

BY JOSEPHINE STURGIS
(AGE 9).



"WILD DUCKS" BY ALLEN POTTER, AGE 9. (THIRD PRIZE,
"WILD-BIRD PHOTOGRAPH.")

ON a Saturday evening I was locked in a room by mistake. My father and mother tried to unlock the door from the outside, and they tried for an hour but were not able to do it. Then, about half-past eight, my father telephoned to the fire-engine department, to ask them if they would bring a ladder and get me out of my room, which was on the second story. They could not understand what he wanted, so he had to go on his bicycle to the engine-house, which was not far off. He had three firemen come up with a ladder and

get me out. I put on my stockings and wrapper, but I was very sleepy, as it was getting late.

The firemen put the ladder up to my window. Then one of the men came up and opened the window, and took me in his left arm and said, "Don't be afraid, little girl."

Then he went down very fast and carried me inside the house again.

He went up once more to see if he could unlock the door from the inside.

He unlocked it without any trouble.

Then I went back to bed and went to sleep, for it was nearly ten o'clock and I was very sleepy.

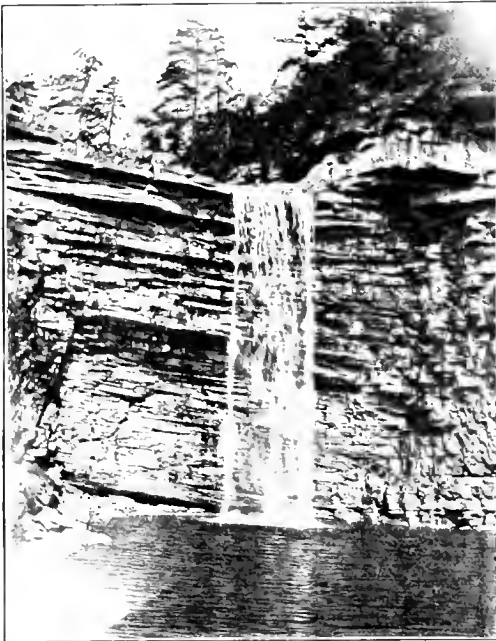

"A WASTING FALLS" (MINN.). BY H. ERNEST BELL, AGE 13.

SUMMER DREAMS.

BY MARGARET STUART BROWNE (AGE 15).

(*Honor Member.*)

Now gold-haired summer, crowned with poppies red,
Draws the slow sun across the radiant sky
Till, smiling, in the west he sinks to sleep,
Lulled by the waking owl's long, fretful cry.

Now are the dusty shadows long and slim
Upon the lawn, where chestnut spikes of snow
Shower fragrant flakes upon the dewy grass
To kiss the timid daisy-buds below.

It is a time of dream and distant song,
A time when winds but sigh, and wavelets croon,
Of long, sweet days and music-haunted nights
Whose star-spun veils half hide the slender moon.

Dream, by the spell of sea and sky bewitched;
Forget the gray, sad world of ceaseless pain;
And if, by chance, you should to care awake,
Return to daisy drifts and dream again!

Harsh winter soon will menace us with gloom,
And still the madrigal of brook and stream,
Rejoice in summer, for, on cold, dark days,
Its memory gives you wherewithal to dream!

A SUMMER DAY.

BY MARY YENLA WESCOTT (AGE 15).

(*Honor Member.*)

The sun that 's shone the whole day long
Has hidden from our sight,
And dark clouds gather overhead
Now that 't is almost night.

Down in the woods the wild flowers small
Have closed each wondering eye,
And little drops are tumbling fast
From out the summer sky.

Oh, quicker now they trickling come,
On field and vale and hill;
All Nature 's wrapped in garments soft,
Her voice is hushed and still.

She gladly welcomes this small shower,
So sweet and soft and cool;
And brighter will each shadow be
Reflected in the pool.

The rain falls slow—the clouds disperse,
Away they swiftly fly,
The sun shines forth again—and lo!
A rainbow spans the sky.

A STRANGE ADVENTURE.

BY ALICE CONE (AGE 12).

(*A True Story.*)

MANY years ago, when my native town was first settled, one Noah Bartholomew bought a tract of land in the new settlement and moved his family and all their household goods up from Connecticut on an ox-sled.

His journey lay on the east side of the Connecticut river, and he traversed the way early in March, intending to cross on the ice a few miles above his farm. But alas for his hopes! When he reached the bank where he intended to cross, he found he was too late! The strong March wind had started the ice, and the Bartholomew family watched the lengthening cracks in the broad expanse with sinking hearts. Would they have to stay on the river bank until the spring freshet was over, a matter of several weeks? But the father had no idea of remaining. Going to a neighboring settler's cabin, he told the men there he must get over the river somehow, before the ice broke up. The pioneers were always ready to help one another, so, armed with strong poles, the father with his two sturdy sons set out with Mr. Bartholomew for the river. The men led the oxen down the bank, and out upon an immense cake of ice just starting away from the river bank.

It was then that the pioneers' poles came into use, for they thrust them down into the inky water, and thanks to their strength and the thickness of the ice, they managed to pole the cake across the river safely, with all the family on it, and assist them up the bank. They refused all pay, saying, "Perhaps you can do as much for us some day." It was an easy task for the long-legged pioneers to cross again on the groaning and creaking ice to their cabin home, and the Bartholomew family reached their destination in safety.

A STRANGE ADVENTURE.

BY JOHN L. TAYLOR (AGE 12).

MY great great grandfather, a Captain Coe, had a strange adventure, and I will relate it. He was a whale-fisher, and had a ship and full equipment. He sailed around the globe, and I think he was very rich.

One day he was sailing along when they sighted a sperm-whale. He and a few others went out in a small boat and tried to harpoon the whale. When the whale saw them coming, he came at them, lashing the water into foam all around him. Straight for the boat he came, and as swift as an arrow. As it came Captain Coe stood up and aimed a harpoon for his side. It was thrown, but missed the moving target. Captain Coe was dragged from the boat, and, as he fell, he heard the crash with the mingled cries of his companions as the whale struck the boat. He did not sink as he was expecting, but landed on something soft. It was the tail of the sperm-whale. He rode about one hundred yards, this being in the direction of his vessel, which was near him. As he neared the vessel, he prepared to dive and come up at the other end, but he was thrown violently from the whale, and was lifted upon the deck, where he landed upon a bundle of canvas.

He was unhurt, for, although he had been picked up roughly, he had been unhurt all the time riding madly along in mid-ocean. I do not know anything more about him, but I think he came back to port all right. Maybe this story is untrue, because it is only a legend.

SUMMER DAYS.

BY BEANCIIE FLEMING (AGE 15).

(Honor Member.)

We 've a post-box in the garden
Where the hollyhocks grow tall,
And the ivy climbs unhindered
On the ancient, crumbling wall.
It 's a secret shared between us—
No one knows the reason why
We go roaming there so often,
Just we two, my chum and I.
And the box is never empty;
Just an apple, rosy-red,
Or a note to say, "I love you,"
Simple words that can't be said,
Or my love-lass comes to meet me,
And we dream there all alone,
Till the summer sun has faded
And the birds have homeward flown.
But there 's no one knows our
secret,
So they never bother nigh;
And the garden seems to love
us,
For chum 's chum, and I
am I.

THE PANSIES.

BY ANNE EUNICE MOFFITT
(AGE 5).

I LIKE the pansies. They grow so nicely, and the more I pick them the more they grow. The more I see them, the more I like them. They 're in a garden. They 're blue and white and yellow and brown and black. They think about the rain coming

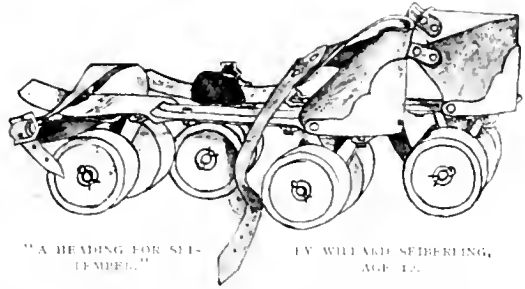
"A HEADING FOR SEP-
TEMBER."BY WILLARD SEEBERLING,
AGE 14.

down and about being watered. They think about me. They think my dolly 's good, and everything 's nice and beautiful. I pick the faded pansies and the faded leaves off the geraniums, and I have a sand box and I love it very much. And the pansies like me to come and water them, and the pansies love me. The pansies have lots of friends to play with, and they shut their little eyes and go to sleep at night, and I love my little bed of pansies and the baby does too.

SUMMER.

BY CATHARINE E. JACKSON (AGE 14).

To run on the smooth, hard beach,
To feel in your face the spray,
To leap and jump and shout,
And watch the gulls at play.

To rush with the collie dogs
And feel the wind in your hair,
To avoid the incoming waves,
Oh, sport like that is rare!

To lie in the cool, green wood,
With Nature an intimate friend,
And watch the small wild folk
To their plays and duties attend.

Or to wander around the farm
And hear the rustling maize,
While you eat a golden peach,
In those glorious summer days.

To live like a gipsy, outdoors,
Happy and careless and free,
A child of Nature yourself,
Oh, that is the summer for me!

SUMMER SUNBEAMS.

BY KATHARINE S. SHINDHAM
(AGE 8).

MERRY little sunbeam,
Dancing in the air;
Merry little sunbeam,
Playing in my hair.

Merry little sunbeam,
Shining all day long;
The birds they rest together
And sing a happy song.

You shine upon the roses,
You shine upon the trees;
You shine around as if to say:
"There 's work for busy bees."

"A FLOWER STUDY." BY FLORENCE V.
REYNOLDS, AGE 14.

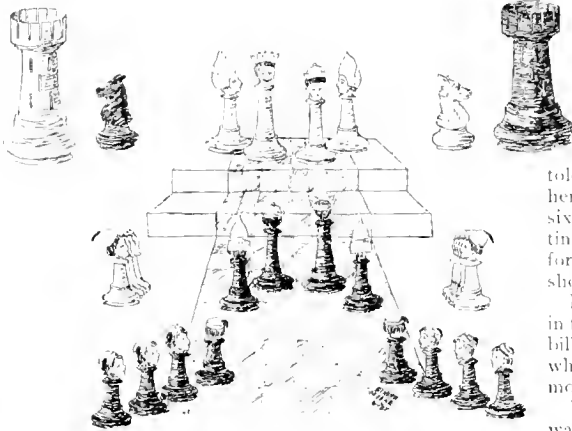

"A SEPTEMBER RECEPTION." BY GLADYS MOORE, AGE 17.
(SILVER BADGE.)

SUMMER.

BY HOVI SHERMAN (AGE 8).

SUMMER is the time to play,
In the fields among the hay.
Summer winds from off the seas,
Wave the branches of the trees.

A STRANGE ADVENTURE.

BY MARY PEMBERTON NOURSE (AGE 13).

THE word adventure is often interpreted as an exciting and unforeseen occurrence, but under the broader definition of a "chance of danger," my story will have to rank.

One day, about seventy years ago, my grandfather received the following communication:

"MAJ. CHARLES J. NOURSE,
"Georgetown, D. C.
"You are an old soldier. Come
to see me, I have something for
you to do."
"NICHOLAS BIDDLE"

Upon going to see Mr. Biddle, who was president of what is known as the "Old United States Bank," my grandfather found that the business which the bank wished to intrust to him was the distribution of \$3,000,000 among its branches on the Mississippi.

That afternoon Major Nourse carried home many sheets of uncut bank-notes.

After supper my grandfather came into the family sitting-room with several sheets of bank-notes, which he allowed his children to separate, while he told his wife and oldest daughter of the journey which he was to undertake.

He asked his daughter to go with him, telling her that, to avoid suspicion, the money was to be carried in her "carpet-bag."

When all was ready my aunt and her father started on their long stage journey.

Naturally, in a journey that took so many weeks, there were many adventures, but because of the League's limited space I will tell only one.

One night during their pilgrimage, upon stopping at an inn, my aunt with her baggage was put into a room the door of which could not be fastened. She was shocked when she made this discovery, but, for fear of creating suspicion, she told no one and retired early, determined to watch her charge. All through that long night the girl of sixteen watched the treasure intrusted to her, forgetting physical pain and exhaustion, absorbed with plans for the protection of her valuable baggage, if this should be necessary.

Remembering the enormous value of the notes—for in those days three millions seemed as great as three billions would to-day—and shuddering to think of what might happen in that night, she waited for morning.

It came and brought relief to her mind, but there was no time for physical rest. That must wait until the mission was accomplished.

In a short time the money was distributed and they were able to go home, my aunt taking with her a pleasant memory of her adventurous journey.

A SUMMER LULLABY.

BY ALINE MURRAY (AGE 16).

THE little waves break on the silvery sands,
The sun sinks low in its glowing heat,
The far-off cry of the whippoorwill
Comes through the duskiuess, faint and sweet.
Hush thee, my little one,
Rest, for the day is done;
Sleep, little one, sleep.

A glimmer of sails on the moonlit sea,
The whispering waves with their music low,
While over the sea bends
the lady-moon
Crooning a lullaby soft
and slow.
Hush thee, my little
one,
Rest, for the day is
done;
Sleep, little one,
sleep.

A STRANGE ADVENTURE.

BY HARRIETTE KYLER
PEASE (AGE 17).

ONE day last summer, when we were in Michigan, we decided to explore a great bluff which was across the lake from our hotel. We were told that we must be very careful or we would get lost, and although we

heeded this warning we did get lost, and as a storm was coming up we began to grow very anxious. Just as the storm seemed about to break we espied a little hut, and ran to it for shelter.

When we opened the door what a surprise greeted our eyes!

A bright fire was burning on the hearth; by it sat a little old woman knitting briskly. A large black cat



"A STUDY OF A FLOWER" BY ETHEL MESSEROV, AGE 15

slumbered before the fire, and in the chimney corner was a great home-made broom.

As soon as she saw us she bounced out of her chair and seized the broom, screaming out something in a foreign tongue as she did so. We girls began to get frightened, but when one of the boys assured her that we meant no harm and only wanted shelter from the storm, she replaced her broom and motioned for us to sit down.

Soon afterward the storm broke and we were glad that we had a shelter from the storm. The little old

have come to look for her name, and last, but not least, because we are both "lar beels."

I am very proud of being a native of "The Old North State."
Yours truly,
MARY YVILA WESCOTT (age 13).

MENHA, P. I.

DEAR ST. NICHOLAS: I have taken you for a year and a half, and I like you best of all the magazines. I live in Zamboanga, Mindanao, and I like it very much. In Mindanao there are very bad Moros, and there is one who is called D. today; the soldiers are trying to catch him, though they are having a pretty hard time of it. But as the same as chief; and they often turn hurriedly, and they think that if they kill a Christian they will go to heaven on a white horse. Harmentendo is the same as murderer. They go about in the street with big knives. The Moros have boats that are made out of trees and hollowed out, to keep their boats from turning over, they put bamboos on the sides. The Moros chew a kind of nut called betel nut, which makes their teeth black. I am twelve years old.

Yours truly,
LEONARD WOOD.

LAPRAKIE PROVINCE, QUEBEC, CANADA.

EDITOR OF THE ST. NICHOLAS LEAGUE:

Sir, or Madam, truly your attention I implore
To the poor unhappy mortals who are put without the portals,
On the outside of the portals of the dearly-loved League's door.

May n't we have some competition? Age is only a partition,
We who send you our petition,—who compete may nevermore,—

Are no older in our seeming though more lonely in our dreaming.

Than the ones who're less than eighteen, while our years, alas! are more.

If we may, within the pages of the League (despite our ages),
Hold a competition, truly we will bless you evermore!

LORENA FOGARTIS (League member, age 16).

Other valued letters have been received from Daisy Bayne, Edna Behre, Elizabeth A. Steer, Morris Lowell, Louise Ballot, Anna Clark Buchanan, Mary Brown, Evelyn M. McPeters, K. Jean Middleton, Cornelia S. Penfield, Lillian Haave, Marguerite Hyde, Florence DuBois, Josephine Holloway, Lester Small, Clifford H. Pangburn, Marjorie K. Peck, Harriet Bingham, M. Opie L. Ward, Harold S. van Buren, Henry B. Dillard, Raymond C. Ide, Fern Porter Lemly, Elizabeth Beal Berry, Doris M. Shaw, Lannie Tutweiler, A. Waldo Stevenson, Douglas S. Warren, Elizabeth Morse, Gladys Richardson, Marguerite Kupperecht, Gladys Louie Cox, Catharine F. Jackson, Belle Baird, J. H. Ishell, Lewis S. Combes, Marjorie Miller, Martha Sherman Stringham, Alice R. Altahan, Elsie J. Taylor, Christine Schöff, Marion Stevenson, Alice Adair Loos, Elizabeth Park, Edna Krouse, Kate S. DeWolf.

GOOD-BY, SUMMER.

(Illustrated Poem.)

BY KATHRYN SERRAQUE DE WOLF (AGE 15).

LITTLE flowers, autumn's here;
Cuddle down, each drowsy dear—
Just a few may stay up late;
No, you won't have long to wait.
Snug you 'll sleep the winter thro',
Soon to gladden earth anew.



woman did not seem to be in the least disturbed by the tempest, and began to prepare her evening meal, muttering all the time to herself, which was rather alarming.

When the simple repast of black bread and soup was ready she invited us to help ourselves. We did not fancy sitting to the table with such a strange old woman, but fearing that we might offend her we accepted her invitation and did ample justice to the simple fare.

The storm having past we inquired in what direction the lake was, and the way having been pointed out we took leave of the little hut and its strange inmate. We soon afterward found our boat, and in a short time arrived safely at the hotel landing.

When our landlord heard of our adventure he exclaimed, "That was old Maria. The stupid country people think she is a witch. It's a wonder she did not chase you off with that broom of hers, as she—"

But I think one story is enough for this time; perhaps I may tell the other some time in the future.

LEAGUE NOTES AND LETTERS.

We are sorry to say that the little story published in June, entitled "How the Count Won His Kingdom," was not original, but taken from La Boulaye's fairy tales. La Boulaye called it "The Three Fishes." Like every other copied contribution we have ever published, it was reported by more than one reader. The League editor cannot read everything that has ever been published, but among all the many thousand members of the League there is no possible chance for an offense of this kind to escape notice. We have repeated this so many times that it seems almost incredible that any one will still run the risk of exposure. Fortunately the story was not awarded a prize, for the reason that it was not strictly speaking a fairy story and was therefore not within the requirements of the competition.

POPULAR BRANCH, N. C.

MY DEAR ST. NICHOLAS: My gold badge came a few days ago. It is beautiful, and I cannot tell you how I appreciate it. I feel fully repaid for all I have done while striving for this bit of gold and blue.

Dear St. Nicholas, you will never know of the joy you have brought into the life of a lonely little girl, and never, oh never, can you realize what it meant to me when after years of endeavor I found that *I had won!*

Dear St. Nicholas, thank you again and again for this, and also for the encouragement of seeing my name on the Roll of Honor and for the silver badge awarded me last year.

I was so glad to see in the February and March numbers poems by Maud Shackelford. For the poems themselves, and because I

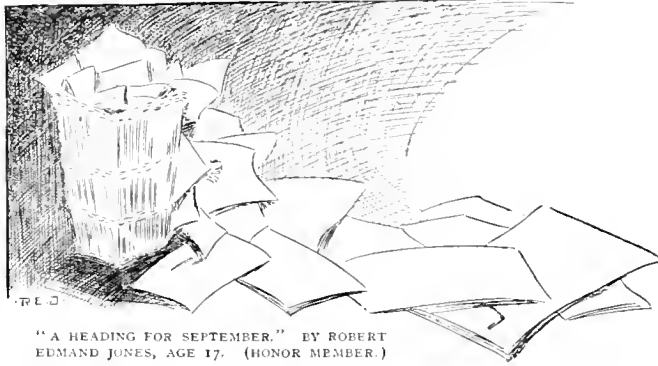

"A HEADING FOR SEPTEMBER." BY ROBERT EDMUND JONES, AGE 17. (HONOR MEMBER.)

THE ROLL OF HONOR.

No. 1. A list of those whose contributions would have been used had space permitted
 No. 2. A list of those whose work entitles them to encouragement.

VERSE 1.

- Elliot Q Adams
- Mary Travis Heward
- Jeanette Covert
- Grace Leslie Johnson
- Clara Shanafelt
- Clement R. Wood
- Helen Janet Smith
- Maud Dudley Shackelford
- Maude H. Brisse
- Louisa F. Spear
- L. Beatrice Todd
- Ethel M. Dickson
- Olive Mudie-Cooke
- Nannie Clark Barr
- Dorothy P. Wetherald
- Cora M. Westcott
- Jean Plant
- Margaret Dew
- Rospah P. Goff
- Georgia Myers
- Sturdee
- Elsa Clark
- Dorothy Keeley
- Josephine Freund
- Eleanor Johnson
- Marguerite Stuart
- Hazel L. Raybold
- Ruth H. Keigwin
- Jessie Freeman Foster
- Frieda G. Carty
- Mary Elizabeth Pidgeon
- Elizabeth V. R. Lumont
- Alma Jones
- Margaret Ewing
- Aileen Hyland
- Dorothy St. John Mildmay
- Dorothy Smith
- Margaret Richmond
- Susan Warren Wilbur
- Isabel D. Weaver
- Adelaide Nichols
- Rolfe Humphries
- Wilhelmine Zwickler

VERSE 2

- Elizabeth Toof
- Emily Rose Burt
- Genevieve Fox
- Mary Elizabeth Mair
- Ruth Perce Getchell
- Lucile D. Woodling
- Ruth M. Hapgood
- Camilla Ringhouse
- Grace Canner
- Abigail F. Jenner

- Phyllis Brooks
- Dorothy Douglas
- Enid Foote
- Cuthbert Vail Wright
- Jessie May Furness
- Corinne Benoit
- Alice G. Baldwin
- David Fishel
- Ella T. Howard
- Helen Hinman
- Coraelia Mallett
- Ruth Greenbaum
- Elizabeth A. Steer
- Alice Washburn
- Geneva Anderson
- Rosamond Kornreich
- Helen Harrington
- Gladys M. Adams
- Marjorie R. Peck
- Margaret Wing Stevens
- Mildred Seitz
- Twila A. McDowell
- Emmeline Pradshaw
- Katharine M. Sherwood
- Charles Ellison
- William Willard Burke
- Mary Lee Turner
- Juliet Ford
- Eulalie Barker
- Marjorie Meeker
- Warren Karner
- Lawrence B. Johnson
- Dorothea Bechtel
- Caroline Ballud Talbot
- Katharine Rutan Neumann
- DeWitt Clinton Jones, 3d
- Norman Taylor
- Marie Armstrong
- Helen Wyman
- James Davies
- Elizabeth G. Solis
- Vera Viola van Nes
- Arthur Perring Heward
- Linda W. Baker
- Theresa R. Robbins
- Helen May Baker
- Pallas White
- Joel Goldthwait
- Madeleine Bunzel
- Roschen Baker
- Lowry A. Biggers
- Marguerite Weed
- Gretchen Stirling James
- Marjorie D. Allen

PROSE 1.

- Dorothy Nicoll
- Lydia Gibson
- Frances Jeffery
- Gwendolene Tugman
- Fulvia Varvaro
- Roscoe H. Vining
- Phyllis M. Clarke
- Hadassah Backus
- Freda M. Harrison
- Dorothy Elizabeth True
- Laura Heward
- Ruth C. Wood
- Harold Blood
- Harriet E. Spitzli
- Harnet E. Margerum
- Irene Bowen
- Leila Nielsen
- Amy Nairn
- Edna Hanawalt
- Loretta Lappington

PROSE 2.

- Elizabeth Marvin
- Allen F. Brewer
- Agnes R. Lane
- Ruth McNamee
- Ethel Berrian
- Juliet Grant Moore
- Madelaine F. H. White
- George Switzer
- Harriet Eleanor Munroe Webster
- Katharine L. Marvin
- Ada M. Nielsen
- Olds MacMillan
- Henry B. Dillard
- Dorothy McL. Yorke
- Joseph E. Larkins
- Faye B. Grantham
- Frances Gordon
- Edith Pine
- Dorothy Corson
- Elizabeth Hirsch
- Nancy Payson
- Bessie Stella Jones
- Dorothy MacLure
- Alice S. Hopson
- Nellie Elgutter
- Joan Sperling
- Lalite Wilcox
- Grace Gates
- Nellie Foster-Comegys
- Catharine H. Straker
- Marjorie Bailey
- Helen Davenport Perry

- Muriel C. Evans
- Joseph C. Weber
- Anna Zucker
- Florence Webster
- Seth Harrison Gurnee
- Charlotte Waugh
- Carna Eaglesfield
- Robert Schulkers
- Grace F. Slack
- W. Howard Smith
- Kate Sargent
- Florence E. Case
- Mathilde Burke
- Alice Humphrey
- Kathleen L. Grace
- Isabel Coolidge
- Marion Myers
- Alma Ward
- Wilson Roads
- Webb Mellin Siemens
- Elsa Hempel

•DRAWING 2.

- Lucy E. B. Mackenzie
- Emily W. Browne
- Helen H. Stafford
- Mabel Frances Whitehead
- Carl Schmitt
- William Robert Wilson
- Dean C. Throckmorton
- Edward C. Tully
- Jennie S. Fernald
- Margaret Naumburg
- Harriette Grant
- Albert Hart
- Irma J. Diescher
- Constance Whitten
- Eilleen Hudson
- Maurice Rosenberg
- Rena Kellner
- Ernest J. Werner
- Mary Hazeline Fewsith
- Virginia Witmer
- Beth May
- Helen Keading
- Jessie Hewitt
- Margaret T. Lighthall
- Harry Stevens
- E. Marguerite Route-Jeje
- Matilde Kroehle
- Harriet F. Hale
- Ruth Cutler
- Anita Moffett
- Mabel W. Whiteley
- Piero Colonna
- Elizabeth Keeler
- Myron C. Nutting
- Isabel G. Howell
- Martha Sherman Stringham
- Esther Q. Tiffany
- Sarah L. Coffin
- Cuthbert W. Haasis
- Dora B. Taylor
- Heather P. Baxter
- Evelyn Cannon
- Margaret Pilkington
- Mary Falconer
- Natalie E. Duncan
- Katherine Dulcebella Barbour
- Olive Garrison
- Frances Morrissey
- Mary R. Paul
- Anna Graham Wilson
- Howard L. Seamens
- Elizabeth Eckel
- Mabel Alvarez
- Margaret Wilkins
- Mildred Andrus
- Helen Shufeldt
- Wayne E. Stevens
- Mary Anderson Woods
- Bryden Pease
- Helen Dawley
- Mollie Bulloch
- Dorothy Eichlitz
- Myron A. Hardy
- David Keith Johnston
- Ruth Adams
- Barbara N. Richardson
- Frances Powell
- Ray McCallum
- Lois Treadwell
- Marian Walter
- Eleanor Keeler
- Fannie Bean

DRAWING 1.

- F. Irwin Smith
- Margaret Dobson
- Ella Elizabeth Preston



SEPTEMBER.

"A HEADING FOR SEPTEMBER." BY KATHLEEN BUCHANAN, AGE 10.

- Dorothy Ochtman
- Edwin G. Crani
- Helen N. de Haven
- Joseph Stenback
- Phyllis McVickar
- Harry B. Leopold
- Vera M. Demens
- Margery Bradshaw
- Carl B. Timberlake
- Marjorie Lyndon Ward
- Joseph Hayes Burchfield
- William G. Chrisp
- Alice Seabrook
- Harold W. Whitlock
- Frances Kathleen Crisp
- Josephine Holloway
- Katherine Mary Keeler
- Ruth Thomas
- Dorothy Bunker Pringle
- Charles H. Baker, Jr.
- C. Rollin Larrabee
- Lorenzo Hamilton
- Charles Duncan
- Katharine A. Robinson
- Mary A. Jones

W. R. Barbour
Mildred C. Jones
Genevieve Bertolacci
Ernest J. Clare
Leonard Ochman, Jr.
William Westring, Jr.

PHOTOGRAPHS 1.
Elizabeth Weyer-
baeuser
Frances F. Fulton
Lawrence V. Sheridan

Alice H. du Pont
G. Huntington Wil-
liams
Janet G. Camp
Kuth W. Leonard
Robert C. Seamans
Elythe Waterman
Marjorie Garland
Katharine Leonard
Lawrence Day
Constance Freeman
Eveline P. Weeks
Viola Bogert

Eleanor B. Danforth
Thomas C. Cole
Vincent H. Godfrey
Charles D. Osborne
Roland Redmond
Harry F. Cromwell

PUZZLES 1.
James B. Diggs
Elizabeth Beal Berry
Harry W. Hazard, Jr.
Harold Alvarez
Mary Angelo

SPECIAL NOTICE.

UNLESS contributors prepare their offerings according to the simple rules given on the last League page of each issue, they cannot compete. It is impossible to award a prize to one who does not give his age, or his address. There were a number of careless members this time who sent very fine work indeed. Three of these would have received prizes—one of them a gold badge—if the contributions had been properly prepared. This is too bad, for among the hundreds of contributions received prizes are hard enough to win, without letting any chance slip away through forgetfulness. Remember, the contribution *must* bear name, age, address, and indorsement. Otherwise it is thrown away.

PRIZE COMPETITION No. 72.

THE St. Nicholas League awards gold and silver badges each month for the best poems, stories, drawings, photographs, puzzles, and puzzle-answers. Also cash prizes of five dollars each to gold-badge winners who shall again win first place. This does not include "Wild Animal and Bird Photograph" prize-winners.

Competition No. 72 will close **September 20** (for foreign members **September 25**). The awards will be announced and prize contributions published in **St. Nicholas** for **December**.

Verse. To contain not more than twenty-four lines. Title, "A Log Fire."

Prose. Story, article, or play of not more than four hundred words. Subject, "A Queer Pet."

Photograph. Any size, interior or exterior, mounted or unmounted; no blue prints or negatives. Subject, "A Country Road."

Drawing. India ink, very black writing-ink, or wash (not color). Two subjects, "The Christmas Fireplace" (from life) and a **Heading or Tailpiece** for December.

Puzzle. Any sort, but must be accompanied by the answer in full, and must be indorsed.

Puzzle-answers. Best, neatest, and most complete set of answers to puzzles in this issue of **St. Nicholas**. Must be indorsed.

Wild Animal or Bird Photograph. To encourage the pursuing of game with a camera instead of a gun. For the best photograph of a wild animal or bird taken *in its natural home*: **First Prize**, five dollars and League gold badge. **Second Prize**, three dollars and League gold badge. **Third Prize**, League gold badge.

RULES.

ANY reader of **St. Nicholas**, whether a subscriber or not, is entitled to League membership, and a League badge and leaflet, which will be sent on application.

Every contribution, of whatever kind, *must* bear the name, age, and address of the sender, and be indorsed as "original" by parent, teacher, or guardian, *who must be convinced beyond doubt that the contribution is not copied*, but wholly the work and idea of the sender.

If prose, the number of words should also be added. These things must not be on a separate sheet, but *on the contribution itself*—if a manuscript, on the upper margin; if a picture, on the margin or back. Write or draw on *one side of the paper only*. A contributor may send but one contribution a month—not one of each kind, but one only.

Address:
The St. Nicholas League,
Union Square, New York.



"A FARM SKETCH." BY CORDNER SMITH, AGE 17. (HONOR MEMBER)

Irene F. Wetmore
Jeanie H. Kiockead
I. Clifford Smedley
Helen Johnson
Hilda C. Foster
William Smith
Margaret Armour
Caro Kingman
Katharine E. Pratt
Jessie Voight
Margaret Colgate
Warren Ordway
Reginald C. Foster
Stathers Dunn
Albert William Honeywell, Jr.
Margaret McKittrick
Edna M. Stevens
Paul Wormser

Charles L. Sherman
Austin Dodge
Leslie V. Spencer
"Two Puzzlers"
F. Adelaide Hahn
Buford Brice

PUZZLES 2

Elsie Margaret Hunter
Henry Morgan Brooks
Margaret Spahr
Theodore C. Browne
Hamilton Fish Armstrong
Willie O. Dickinson
Gladys Richardson
Abe S. Behrman
Philena F. Fine
Lawrence Levensgood
Ethel Dietrich
Lila H. Dunkin
May W. Ball
Katherine Hitt
Arthur J. Goldsmith
Elizabeth Spicer
Dorothy Culp
Isabel McGillis
Eleanor S. Sanger
Jessie Kennedy
Lillian L. Fischer
Eugene Clark Scott
Freda M. Schultz
Edna Browning

PHOTOGRAPHS 2.
Christina B. Fisher
Lively Clayton
Fairfield E. Raymond
Lincoln Clark
Preston Courseen
Charlotte H. Sawyer
Mortha Hollister
Earle Hoyt Ballou
Susan J. Appleton
Helen L. K. Porter

Douglas S. Warren
George Wright
Selney Moise
Sarah W. Davis
Elizabeth A. Gest
Rainhard Heeran
Hardenia R. Fletcher
Thomas Turabull, 3
Florence C. Jones
Mary Ellen Willard
Marian V. S. Toedt
J. Parsons Greenleaf
Alice Shirley Willis
Florence R. T. Smith
Mildred Quiggle
John Orth
H. B. Duncan, Jr.
Pendleton Schenck
Joseph S. Webb
W. Kenneth Mackenzie
Dorothea dePonte
Williams
Alexander B. Morris
Janet E. Buchanan
Marion H. Tutbill
E. Bunting Moore
Harold P. Murphy
Margaret Griffith
Sineley Gambie
Lmily Yocum Brownback
Elliot Dunlap Smith
Dorothy Dudley Storer
Fred Klein

SOUVENIR POST CARDS.

The following named League members would like to exchange souvenir postal cards: E. Marie Cheney, 314 Lyndale Ave., S., Minneapolis, Minn.; Josephine McMartin, 1-3ns-town, N. Y.; R. Simpson, Southmount Cameron, Tasmania, Australia; Wilmer Jackson Gross, Morrison Ave., San José, Cal.; Marion L. Decker and Catherine Decker, Mt. Halerowe, Johnstown, N. Y.; Evangeline Keefe, Madison, Me.; Bertha Rushworth, same address.



"SCHOOL AGAIN." BY EARL PARK, AGE 13.

BOOKS AND READING.



SCHOOL-DAYS AGAIN.

WE all know that at first it is not at all hard to take up the routine of school-work, even after the delightful freedom of vacation days. There is a pleasant novelty in the fresh, clean-smelling new school-books, in the beginning of new studies, in the faces of new-comers; but we also know that before long the freshness is gone and there is danger that school duties will begin to become a burden. Edward Everett Hale has written a clever little book of essays entitled "How to Do It," wherein he gives advice to young people upon a variety of everyday matters. In regard to the hours spent in school, he makes the wise suggestion that the way to make these hours as swift in flight as those of vacation time is to give one's self heartily to the task in hand, whatever it may be. Who of us has not seen a child give more time to worrying and fretting over a task than would have been ample to complete the task itself? And besides, the doing of the work would have been much less disagreeable to all parties concerned than the whining and complaining that took its place.

Though the halls of literature are full of delights, they can be entered only through the outlying courts where the little scholar serves an apprenticeship of routine work. Those who love books must not forget that the knowledge of books cannot be won save by many a day of faithful service in the school-room.

A TRIBUTE TO READING.

THE president of Hamilton College, in an address to some public-school teachers, said in effect that the knowledge he had gained by reading was more valuable than all the rest he possessed, and declared that if schools failed to give a love for reading, they failed in the most important part of their duty.

FOR READERS OF FRENCH.

IN an article in the July number of "The Review of Reviews," a French lady, Stephane Jousselein, speaks in most flattering terms of the interest of American women in French literature, and especially commends American young girls as being unusually well read. She thinks, however, that some of the books which should be best known to our young readers of French are often neglected by them, and gives a few suggestions as to books especially suited for the reading of young girls. In the hope that her suggestions may be of use to young students of French literature, we repeat a few of them here.

Though it is often read in schools, perhaps not all young students of French are aware how charming is the little volume, by Alphonse Daudet, entitled, "Lettres de mon Moulin." This book is equally delightful in subject and in style, and should be familiar to all American readers of French stories. Three authors who are strongly recommended by this French visitor are André Theuriet, Victor Cherbuliez, and Leon de Tinseau.

We shall name but two more books, although these by no means exhaust those suggested in the original article: "Mon Oncle et mon Curé," by Jean de la Brété and "Le Rêvé," which is by Émile Zola, but is a most charmingly ideal sketch of French country life.

THE CLASSIC BROTHERHOOD.

NOT so many years ago, it was comparatively easy to induce young readers to prefer the best books. The comparison then was between very good books and a class that had little to recommend it. To-day, in the great number of books for the young, there are all grades and varieties between the very poorest and the very best. Many merely commonplace books cannot be fairly condemned as in any way harmful

or foolish; all that can be said of them is that they are not the best. Usually, since they are easier reading than the best books, and require no effort on the part of the reader, they will be preferred by young people who are lazy about thinking. Undoubtedly, there is a time for this mere "recreation reading," and the object of this paragraph is only to warn young readers that these second-rate books should not displace their betters.

The best books, the classics of our literature, have a certain relation one to another; the reading of any of the brotherhood makes easier the acquaintance with its fellows. To show briefly what is meant, the young reader is reminded how many are the references throughout literature to such a book as "Pilgrim's Progress," which, it is taken for granted by all writers, will be familiar to their readers. In short, each great book helps wonderfully to understand all others. As to the recreation books, it is a matter of no importance whether they be skimmed or neglected.

WHAT CHILDREN READ. A CHICAGO professor has been securing statements from about three thousand children concerning the books they most enjoyed. From their answers, he has made up a list of one hundred, of which No. 1 is Miss Alcott's "Little Women," and No. 100 is "Peck's Bad Boy." It is at least gratifying that the last on the list came no higher. Three books which were exceedingly popular, being ranked ahead even of many excellent story-books, are Fiske's "History of the United States," a Life of Washington, and one of Lincoln. We should be very glad if some of our Chicago correspondents could send us the full list, as this note is made up only from a newspaper mention.

THREE OLD FRIENDS. THE wife of a missionary in Korea adds a postscript to a very pleasant letter written by her little son, and recommends three books that were great favorites of her own: Irving's "Alhambra," with its charming Moorish legends, John G. Saxe's "Clever Tales of Many Nations," and Mrs. Craik's "A Little Lame Prince." We are glad to mention these, as most of the lists sent us name the same general class of books—books already familiar to most of our readers.

"FRIEND PAUL." THOSE of us who were boys several decades ago remember with delight the books of Paul du Chaillu, whose recent death seemed to his old readers the loss of a friend. No other writer for boys had the same kindly charm as "friend Paul." During his lifetime, and, indeed, until within a few years, many were skeptical as to the truth of his surprising stories of Central Africa; but as the Dark Continent was brought more and more into the light of day, it was seen that Du Chaillu had told the unadorned truth. In the hope of bringing his fascinating writings to the notice of boy readers of to-day who do not already know him, we advise them at their next visit to the library to call for one of his African volumes—for instance, "My Apingi Kingdom." Reading one will be a sufficient introduction, sure to lead to more.

AN OLD AND WISE SAYING. ONE of the wise old doctors of the middle ages, who lived about two and a half centuries before America was seen by Colon, was asked how a man might become learned. He replied, "By reading one book." We should like some of our young students to tell us: who said this; what nickname was given him by his schoolmates; what is meant by the saying, and what modern saying is suggested by the old one.

WAYS OF READING. QUITE as important as what books one likes is why one likes them, for one may select the right book for the wrong reason, or you may make a book very different by different ways of reading it. Skipping is dangerous if you are reading an author who can be depended upon not to waste your time; and if you have a book which is little harmed by skipping, you will probably save time if you skip at once from Chapter I to "Finis." If old enough to read books of your own choice, you are also old enough to know whether it is worth while to give time to any particular book; but do not make the mistake of not reading a great deal purely for amusement. "No profit grows where is no pleasure ta'en." Remember, however, that the "pleasure" may be that of acquiring knowledge or discipline, and that often the most effective studying is done by young people in acquainting themselves with something they do not learn in school hours.

THE LETTER-BOX.

EDITORIAL NOTE.

Through a regrettable oversight, the full-page illustration "A Fourth of July Morning in the Daisy-Field," which appeared on page 776 of the July number was not credited to the photographers who made it. The illustration was from a stereograph made by Underwood & Underwood, New York, and copyrighted 1904, by this well-known firm.

PORTLAND, ME.

DEAR ST. NICHOLAS: I am a little girl nine years old. I have taken you a little over a year, and I like you very much. I am very much interested in Nature and Science. I have a little dog; his name is "Chick"; he is a Boston bull-terrier. I like to read the letters in the Letter-box.

Your loving reader,
BEATRICE B. CRAGG (age 9).

RUMFORD POINT, ME.

DEAR ST. NICHOLAS: I have taken you for four years, and enjoy you very much. I am much interested in "Pinkey Perkins: Just a Boy."

I have a cat whose name is "Molly," and a dog whose name is "Jack." He is very playful.

I have no brothers nor sisters, so I do not have anybody to play with. I go to school. I live about two miles from the school-house. My school has a League; it takes you and enjoys you very much.

My uncle is a representative from Rumford, and I have been to Augusta.

Your interested reader,
SUSAN MARTIN (age 10).

EVELETH, MINN.

DEAR ST. NICHOLAS: I live in Eveleth, Minnesota. Sometimes it is very cold, and yesterday it froze, and during the night the trees and everything were covered with ice; some of the trees were broken and others bent. I have taken the ST. NICHOLAS for five months, and enjoy it very much. I have a cat named "Malty."

I named her that because she is a Maltese cat. I have had her four years, and she will not go outside the yard.

One day, when she had kittens, there came a little black dog in the yard, and when Malty saw him she chased the dog all around the house, and finally she got him in the corner of the yard and she scratched him. He was more frightened of her than she of him. He was whining and barking, and when Malty did let him go, he ran as fast as he could.

This is the first letter I have ever written to the ST. NICHOLAS.

Your sincere reader,
RACHEL HARWOOD (age 10).

ATHENS, OHIO.

DEAR ST. NICHOLAS: I want to tell you about my little half-sister. She is just six months old, and so sweet that I could eat her up.

I have two other sisters of six and three. The baby's name is Winnifred. She is just learning to sit up, and sometimes when she gets a little overbalanced she just goes over, and sometimes she tries to get her feet in her mouth. She laughs nearly all the time.

I like your stories very much, especially "Queen Zixi of Ix." I would like to read some more stories like "Ned Toodles."

I am your loving reader.
EMMA M. GUENTHER (age 15).

NORTH TONAWANDA, N. Y.

DEAR ST. NICHOLAS: I have taken you for just a year, and like you very much. One of my favorite stories is the "Queen Zixi of Ix." I take my ST. NICHOLAS to school as soon as it comes. The other day the teacher read us about Lucy's shopping; when she said there was no more time, everybody looked so disappointed.

I have been longing to get into the League membership, but I am afraid I cannot draw very well.

I am going to try hard so that I can get a badge. I have heard so often of the beautiful badges that I want one very much. I am afraid my letter is getting too long, so I will close.

I am your reader,
AUGUSTA STRADELLA (age 10).

NEW HAVEN, CONN.

DEAR ST. NICHOLAS: I have taken you for three years, and think you are the best children's magazine published.

I am a League member, and I happened to get my badge exactly three years after I took the first number of ST. NICHOLAS. It was on my birthday.

My favorite stories are "Pinkey Perkins: Just a Boy" and "Queen Zixi of Ix."

I have a camera, and I am going to take some pictures for the League.

When I can't find anything else to do, I get my old ST. NICHOLAS and read them over, and I suppose I have read them all about once a month.

I will have to close now.

Your faithful reader,
STANLEY DAGGETT (age 10).

PORT RICHMOND, N. Y.

DEAR ST. NICHOLAS: I have taken you for many years, and have numbers dating back to 1896. I have taken you regularly for the last six years, but I have neglected the League. It is a little late for New Year resolutions, but during 1905 I intend to send more contributions. I give you my highest praise — you are the best magazine for boys.

Yours very truly,
CLARENCE E. SIMONSON.

SPOKANE, WASH.

DEAR ST. NICHOLAS: We have taken you for eighteen years, but of course I have n't, for I am only nine; but, although so young, I am an uncle to a niece, who is about eight months old, and lives at Idaho.

My brother has a dog, an Irish setter, who is fourteen years old. My sister did have a dog, named "Bennie," who was about eight years when he died.

The snow came about three days ago, and I am having a fine time coasting and snowballing. But I must close.

Your loving reader,
WILLIAM RICHARDS.

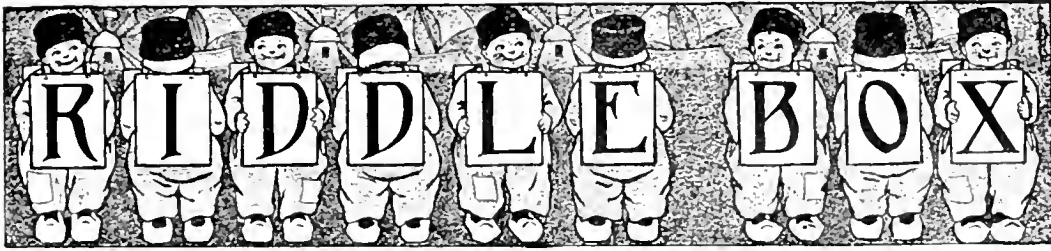

ANSWERS TO PUZZLES IN THE AUGUST NUMBER.

CHARADE. In-come

DOUBLE BEHEADINGS AND CURTAILINGS. Praxiteles. 1. Trumpe-ts, pume. 2. De-risive, Iris. 3. Co-ales-ce, seal. 4. Flexi-ble, ibex. 5. Ab-lati-ve, tail. 6. Fro-to-to-ir, Otto. 7. Me-an-de-ers, Edna. 8. Ap-os-tles, slot. 9. Ho-rgeo-us, gear. 10. Ab-stract, arts.

WORD-SQUARE. 1. Slant. 2. Lower. 3. Aware. 4. Nerve. 5. Trees.

NUMERICAL ENIGMA

Under a spreading chestnut-tree
The village smithy stands.

ILLUSTRATED NUMERICAL ENIGMA. "Be good, sweet maid, and let who will be clever."

TRIPLE BEHEADINGS. George Washington. 1. Fra-grant. 2.

TO OUR PUZZLERS: Answers, to be acknowledged in the magazine, must be received not later than the 15th of each month, and should be addressed to ST. NICHOLAS Riddle-box, care of THE CENTURY Co., 33 East Seventeenth St., New York City.

ANSWERS TO ALL THE PUZZLES IN THE JUNE NUMBER were received, before June 15th, from Helen Marshall - Lauri E. Jones - Russell S. Reynolds - Charles E. Sherman and mother - Dorothy Rutherford - Elizabeth D. Lord - "Allil and Adi" - Nessie and Freddie - Harold S. Hill - Mary Elizabeth Askew - Grace Haren - Edwin N. Little - "Chuck" - Evelyn G. Pat - Harriet Bingham - Marian Swift - Margaret E. Nash - Alpha Society and friends - Marion Smith - Elizabeth Delo - Grace Massonne - J. Joseph S. G. Bolton - Florence Du Bois - Lillian Sarah Burt - Marjorie Mullins - Laetitia Viole

ANSWERS TO PUZZLES IN THE JUNE NUMBER were received, before June 15th, from Lucy W. Harris, 2 - I. C. Bauer-ft, 1 - E. B. Whittemore, 2 - E. Black, 2 - B. Williams, 2 - E. Crampton, 1 - E. Anschutz, 1 - A. Pine, 1 - D. E. Hickok, 2 - E. Cramhall, 1 - M. Kent, 1 - C. Thierot, 1 - M. Boland, 1 - J. E. Kerbaugh, 1 - A. H. Platt, 1 - "Duluth," 8 - S. Martin, 1 - Edith L. Kaskel, 3 - D. Funk, 1 - M. C. Weyand, 1 - H. E. Bowman, 1 - Rosamund Randall, 2 - Christine Fleisher, 2 - I. Hollberg, 1 - M. Plumb, 1 - E. Dreyer, 1 - Adele M. Beatty, 4 - Mildred T. Satterthwaite, 2 - Mildred R. Kahn, 2 - F. B. Beach, 1 - L. Neal, 1 - I. S. Hultze, 2 - A. Eggers, 1 - M. Elliott, 1 - D. P. Murphy, 1 - James A. Noves, 2 - R. Norden, 1 - D. and E. Perkins, 2 - E. Crampton, 1 - W. E. Burr, 1 - L. H. Amy, Jr., 1 - A. B. Lane, 1 - H. Laird, 1 - M. L. Frey, 1 - F. Kriester, 1 - Jeannette Berolzheimer, 2 - H. E. Cushman, 1 - Margaret Donald, 2 - A. T. Dell Plain, 1 - Marguerite Strathy, 6 - Ann Macdester, 2 - M. L. Russell, 1 - Ruth Jepson, 3 - E. Nicol, 1 - Sarah Pattee, 4 - J. Lintz, 1 - Florence Bailey, 5 - I. Entler, 1 - Marjorie Skelking, 4 - H. Bowman, 1 - M. H. Tanberg, 1 - A. S. Hopson, 1 - H. L. Hayes, 1 - M. B. Williams, 2 - H. E. Butcher, 1 - H. G. B., 3 - D. F. Hildreth, 1 - B. W. Baird, 1 - Jean Masten, 1 - Ruggles B. Pritchard, 3 - Caroline Ray Servin, 6 - Hazel Cockcroft, 5 - C. Anthony, 5 - Fred G. Switzer, 4 - Elizabeth Pease, 3 - E. D. Fanning, 2 - C. D. Schutz, 1 - Tanetta E. Vanderpoel, 8 - J. Glynn, 1 - M. Wagner, 1 - R. T. Clapp, 1 - J. H. Elwell, 1 - Prue K. Jamieson, 3 - Louisa M. Orth, 8 - E. Streeter, 1 - Rebecca E. Hilles, 4 - Mary H. Gray, 4 - R. E. Young, 1 - W. A. Putnam, Jr., 1 - R. H. Renton, 1

WORD-SQUARE.

1. A Russian coin. 2. Alliance. 3. A person obstinately wedded to an opinion. 4. Unbound. 5. To penetrate.

LIZZIE GILMER.

DOUBLE ACROSTIC.

WHEN the following words have been rightly guessed and written one below another, the initials, reading downward, will spell the name of a famous man; another row of letters will spell the name of one of his works.

CROSS-WORDS (of equal length): 1. Relating to Syria. 2. To plague. 3. Narrow passages. 4. A Chinese salutation. 5. Outflow. 6. Ruins. 7. An out-of-door party. 8. An exclamation meaning "I have found it!". 9. A reply. 10. To bait again. 11. Chooses.

ALICE M. FISHEL (League Member).

CHARADE.

(Silver Badge, St. Nicholas League Competition.)

My *first* is reached in every race, since races first began;

My *second* is a smoky place, if in it there 's a man;

My *last*, if spared, will spoil the child (than which no saying 's truer);

My *whole* grows by the roadside wild; you've guessed it now, I'm sure.

ELIZABETH H. CRITENDEN.

DOUBLE ZIGZAG.

1	.	.	9
	2	10	
		11	3
			4
			5
			6
			7
			8
			16

CROSS-WORDS: 1. To taunt. 2. A plant. 3. A small horse. 4. An aquatic bird. 5. Idle. 6. A landlord. 7. To expect. 8. An epithet.

From 1 to 8, a poet; from 9 to 16, a novelist.

MARGARET MORRIS (Honor Member).

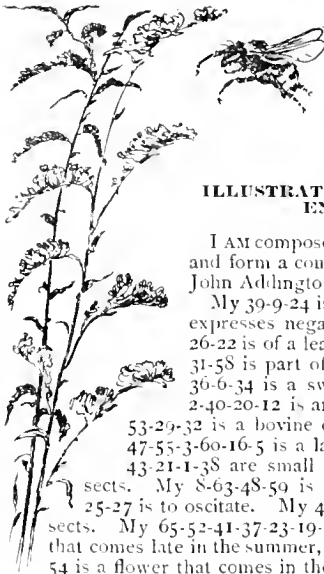

ILLUSTRATED NUMERICAL ENIGMA.

I AM composed of sixty-five letters and form a couplet from a poem by John Addington Symonds.

My 39-9-24 is a color. My 64-49 expresses negation. My 42-15-56-26-22 is of a lead color. My 45-11-31-58 is part of a ship. My 62-18-36-6-34 is a sweet substance. My 2-40-20-12 is an elevation. My 14-53-29-32 is a bovine of the far East. My 47-55-3-60-16-5 is a large insect. My 28-43-21-1-38 are small and troublesome insects. My 8-63-48-59 is sinewy. My 17-35-25-27 is to oscitate. My 4-44-57-7 are busy insects. My 65-52-41-37-23-19-10-50-51 is a flower that comes late in the summer, and my 13-46-33-30-54 is a flower that comes in the early autumn.

V. 11.

CONNECTED WORD-SQUARES.

(Gold Badge, St. Nicholas League Competition.)



I. UPPER LEFT-HAND SQUARE: 1. Courageous. 2. A bird. 3. To turn aside. 4. A stanza. 5. To go in.

II. ADJOINING SQUARE: 1. Sounded. 2. Territory. 3. Close at hand. 4. Apparel.

III. UPPER RIGHT-HAND SQUARE: 1. Evident. 2. To depart. 3. Part of a roof. 4. To prevent. 5. Replies.

IV. ADJOINING SQUARE: 1. A heavenly body. 2. Acid. 3. Surface. 4. Genuine.

V. LOWER LEFT-HAND SQUARE: 1. A masculine name. 2. To frighten. 3. Minded. 4. A place of public combat. 5. An angle in a wall.

VI. ADJOINING SQUARE: 1. A cicatrix. 2. Anxiety. 3. Region. 4. To perse.

VII. LOWER RIGHT-HAND SQUARE: 1. A builder in stone. 2. To idolize. 3. Makes dirty. 4. An architectural ornament. 5. Cozy homes.

VIII. ADJOINING SQUARE: 1. To pull along. 2. To be furious. 3. To assert. 4. A spore.



IX. CENTRAL SQUARE: 1. To hinder. 2. A common verb. 3. A color. TESSIE TAG.

GEOMETRICAL PUZZLE.

(Silver Badge, St. Nicholas League Competition.)

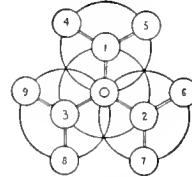

FROM 0 TO 1 and 0, a negative prefix; 014, a word expressing negation; 015, a bending forward; 020, a recluse; 026, a knob; 027, the fruit of certain trees; 030, a feminine name; 038, a horse; 039, to seize; 410, a weight; 414, a small child; 415, a fox; 510, to put on; 514, a speck; 515, to cut off; 620, a small cake; 626, a small boy; 627, yet; 720, a wine measure; 726, a small cask; 727, an exclamation; 830, a poetic word for "commenced"; 838, to stop the mouth so as to prevent speech; 839, unmeaning talk; 930, to invoke evil upon; 938, a small sack; 939, a feminine nickname.

REGINALD A. UTLEY.

DOUBLE BEHEADINGS AND CURTAILINGS.

(Gold Badge, St. Nicholas League Competition.)

1. DOUBLY behead and doubly curtail a little town of Chautauqua County, New York, rearrange the remaining letters, and make a small house. In the same way:

2. Behead and curtail permitted, rearrange, and make a bird.

3. Behead and curtail dwarfed, rearrange, and make a cask.

4. Behead and curtail a kind of cloth used in making flags, rearrange, and make a metal.

5. Behead and curtail rebuked harshly, and leave ancient.

6. Behead and curtail perfumed, rearrange, and make to enmesh.

7. Behead and curtail a firm, rearrange, and make a chart.

8. Behead and curtail inhabitants of India, rearrange, and make help.

9. Behead and curtail sportsmen, rearrange, and make a number.

10. Behead and curtail bandages, rearrange, and make a covering for the head.

11. Behead and curtail a society of scholars, rearrange, and make a measure of length.

12. Behead and curtail keener, rearrange, and make to knock.

When the newly formed words have been written one below another, the initials will spell the name of a celebrated American clergyman born in 1663.

W. S. MAULSBY.



Mary Mapes Dodge

ST. NICHOLAS.

VOL. XXXII

OCTOBER, 1905.

NO. 12.

IN MEMORY OF MARY MAPES DODGE.

DIED AUGUST 21, 1905.

LONG before this number of *St. Nicholas* reaches its readers, the daily newspapers will have brought to them the sad news of the death of the beloved editor of this magazine. Mrs. Dodge had been suffering from a severe illness for several months, and it was hoped that the usual sojourn in her summer cottage at Oteora, New York, might restore her to health. But she steadily grew weaker until the end, which came peacefully on the morning of Monday, August 21st.

To all who knew and loved her it seems almost unbelievable that one who was so vital a part of the lives of those around her has vanished forever from our sight. Mrs. Dodge was always so triumphantly alive and joyous, so "in love with life and raptured with the world"; she had served so long and faithfully in her chosen field; she belonged so thoroughly to her great task, and held so high a place in both public and private esteem, that, as many a sorrowing friend has written, "We cannot imagine life without her." The recognized leader in juvenile literature for almost a third of a century, she was universally honored by the children of America and even of the world — for from shore to shore of our country and across the widest seas her name was held in reverent affection by child-readers and their parents. Two generations

of girls and boys have known her work and learned to love the noble, gifted, kindly nature which that work revealed. Children's faces all over the land broke into smiles of joy at the mention of her name; parents all over the land, knowing well the debt which they and their children owed to her, said many a quiet "God bless her!" in their hearts. Upon her desk to-day are loving, grateful letters from children whose fathers and mothers sent her just such letters in the cramped handwriting of their own childhood twenty-five years ago. "And we love you, dear Mrs. Dodge, as much as we love *St. Nicholas!*" was always the burden of these missives. Every copy of *St. Nicholas* made a personal friend for Mrs. Dodge of every girl and boy who read it, and everywhere she was honored and beloved as one who had done a great work in the world.

But it was not by any luck or good fortune that she accomplished that work; it was by patient, devoted, conscientious labor — by the exercise of noble gifts to a noble end. It was her mission to minister to the thoughts and interests and aspirations of childhood, and for this she was divinely fitted: From first to last — in her delight in simple things, in her simple faith, and in her eager impulses and quick sympa-

thies—she was herself a child. But not in powers—for her powers were of the rarest and the greatest; not in knowledge and wisdom—for there have been few wiser or more accomplished women; not in courage—for her courage nothing could daunt. Yet these high endowments, with all the other manifold gifts of her nature, she consecrated to the service of childhood. To make child-readers happy first, and through this happiness to lead them on to higher and nobler living,—this was her aim and work. And all the joy and sweetness and enlargement which she brought into their lives, they have still and cannot lose.



Mrs. Dodge came of distinguished ancestry, which included, on both her father's and her mother's side, the names of many well-known citizens of New York. General Jonas Mapes had a patriot's share in the War of the Revolution, and was an intimate personal friend of the Marquis de Lafayette; and other members of the Mapes family attained a well-earned distinction a century ago. Her own father, Professor James J. Mapes, has been called a "universal genius"—for he was noted as a scholar, an inventor, a scientist, and an author. Moreover he was a man of wide social acquaintance and a brilliant, humorous, accomplished talker—famous for his wit, and as a story-teller. The foremost men of his day in literary, artistic, and political life—men like Horace Greeley and William Cullen Bryant—were his familiar friends. Captain John Ericsson, who usually kept himself secluded from the world, was a close comrade of Professor Mapes, and a frequent visitor to his home in New York city—a home which attracted the best thought and the best people of the time—the hospitable center of a large literary and scientific circle.

It was into this home that little Mary Elizabeth was born on January 26, 1831. "I had a devoted father and mother and a happy childhood, a remarkably happy childhood, watched over with loving care," is Mrs. Dodge's own tribute to the wise and tender rearing which she received and to the home influences which molded her earliest thoughts.

The picture of Professor Mapes's daughters

in their childhood, painted by William Page, shows Mary, the second daughter, as the little figure in the foreground holding a doll in her arms. "I would not part with my dolly for all their coaxing," she used to say. In this devotion, as well as in the clear, bright eyes of the little girl, which look into our own with such a happy and yet searching gaze, in the frank, earnest, eager, and joyous expression of the round, rosy face, and in the tender grasp with which the motherly arm clutches the dolly, we may surely read prophetic glimpses of the child-lover and benefactor of children that she was one day to become. And as if to fit her for the work, she was, as a good friend once wrote of her, "one of those fortunate mortals at whose christening feast no ill-tempered fairy sulked." She was supremely gifted from the first.

But until she was twice as old as at the time when the picture was painted, she was merely a happy, healthy child, with a buoyant nature and a child's delight in the joys and pleasures of the passing hour,—frolicsome, filled with energy and animal spirits like many another, and taking no thought of time, as the happy days sped by. Before she was ten, however, she had become a great reader, and she early showed her literary bent by celebrating the family anniversaries in "poetical effusions." Some of these stately but comical efforts she used to repeat with gleeful amusement in after years.

The daughters of Professor Mapes never went to school. They gained their education at home under the care of tutors and governesses, being carefully trained, not only in the usual English branches, but in French, drawing, music, and Latin.

There was no such thing in those days as a children's magazine; but there were the great masterpieces of literature, the Bible, the old English ballads, Shakspere, Milton, Bunyan, and Walter Scott. Professor Mapes inspired in his daughters a love for the world's great books, and Mrs. Dodge may have gained from them the crystal clearness and the force of her literary style. As she grew into her teens she grew also more and more fond of writing, and before her girlhood ended was already helping her father in the preparation of his learned pamphlets and essays: and for him throughout her life she

PAUL BAYNE, W. C. MILLER, F. H. J. BOB, THE MOON, THE ANGEL, AND A BOY, BY C. C. HAYDEN.



cherished a boundless pride and love. Both in her home study and her editorial office his picture decorated the wall above her desk.

While still a very young woman, however, she became the wife of William Dodge, a prominent lawyer of New York, and for several happy years a new love reigned supreme in her life, while the claims of husband and children—for two boys had come to bless the fireside—filled the days with peace and joy. Her own home, like her father's, was an ideal one, where the best people and the best influences found always an open door and open hearts. All too soon, however, it was desolated and closed by the sudden death of the head of the household, and with her two children Mrs. Dodge returned to the homestead, a large country house near Newark, New Jersey.

Here her life was mainly devoted to her children. She was not only their mother, but their comrade and friend. She entered into all their daily interests, their work and play; and as time went on she found herself obliged to provide the money for their education. It was for this purpose that she turned to writing.

A small cottage or farm-house which adjoined the orchard on her father's estate was confiscated for use as a study, and Mrs. Dodge and her boys soon transformed it into a cozy "den." In this simply furnished and quaint little abode, far enough away from the great house to insure quiet, she set to work in earnest. Fortunately, everything that she wrote was successful. The periodicals to which she sent even her earliest manuscripts accepted them all and eagerly asked for more.

After the publication in leading magazines of several essays and stories for grown-up readers, Mrs. Dodge brought out, in 1864, her first book—made up of short tales for children—under the title "Irvington Stories." So great was its popularity that the publisher begged for a second series or a sequel. But Mrs. Dodge, meantime, had begun work upon a longer narrative. She was really improvising it as a "good-night story" for her boys—"making it up as she went along," as children say. From Motley's histories and other books her mind was filled with admiration of the sturdy, heroic little nation which for centuries

has held its own against the mightiest powers of Europe and a still mightier enemy—the sea. In the heat of kindled imagination she began to tell her children a story of life in Holland, weaving into it much interesting material from the history of that quaint and valiant country, which at that time she had never seen.

The subject grew more and more absorbing to her. She worked upon the manuscript from morning till night, and sought eagerly for every source of information which could make her pages more true to life or more entertaining to her readers. "She ransacked libraries, public and private, for books upon Holland; made



PROFESSOR JAMES J. MAPES, MRS. DODGE'S FATHER.

every traveler whom she knew tell her his tale of that unique country; and submitted every chapter to the test of the criticism of two accomplished Hollanders living near her. It was the genius of patience and toil, the conscientious touching and retouching of the true artist, which wrought the seemingly spontaneous and simple task."

From the day of its issue, "Hans Brinker" found multitudes of readers, and more copies of it are still sold every year than of the average newly-written juvenile story. Besides its large circulation in America, it has passed through several editions in England; has been published in

French at Paris; in German at Leipzig; in Russian at St. Petersburg; and in Italian at Rome. The French Academy awarded it one of the Monthyon prizes of fifteen hundred francs. In Holland itself a Dutch translation has found a sale of many editions. By a curious coincidence, too, when Mrs. Dodge was in Amsterdam with her son in 1873, a copy of this Dutch edition was recommended to him by a bookseller as the best and most faithful juvenile story of Dutch life that was known in Holland. It was a pleasant experience for Mrs. Dodge when the boy, having purchased a copy, proudly presented it to her, repeating the bookseller's comment, and confiding to him that she was the author of the story. To-day, in our own country and in all English-speaking lands, "Hans Brinker" is a veritable classic of juvenile literature. Even if Mrs. Dodge had done nothing more than to write this book, her place would be forever secure in the affection of child-readers.

But after bringing out, in 1869, a clever little book of home pastimes entitled "A Few Friends," she accepted, in 1870, the position of associate editor of "Hearth and Home," a weekly family paper, of which the editors were Mrs. Harriet Beecher Stowe and Mr. Donald G. Mitchell. On this journal she took charge of the household and juvenile departments, and ere long Mrs. Dodge's reputation as editor equaled that which she had already attained as author. The circulation of the periodical was greatly increased, and the department itself rapidly grew into a very prominent feature of the weekly issues. It was her work in this field which first attracted the attention of Dr. J. G. Holland and Mr. Roswell Smith when, early in the seventies, as directors of the company which now publishes "The Century Magazine," they began to consider the publication of a new juvenile monthly. Their decision really hinged upon hers, for they were heartily ready to undertake the project provided they could obtain her consent to assume its management and become its editor.

Let it be confessed that she had other aims. Ambition tempted her. She was eager to try her hand at novel-writing. Her triumphs in juvenile literature had already exceeded her expectations; she longed for other fields to

conquer. Thus her mind reasoned; but her heart—her heart turned again to thoughts of the children. Many gifted men and women were writing novels; no one was doing all that could be done—that ought to be done—for the boys and girls. Not without a pang of regret, but without further hesitation, she obeyed the call of duty. How clearly she heard, how faithfully she answered the cry of the children all the world knows to-day.

For thus it was that *St. Nicholas* was founded; and from the choice of its title and its first issue, in November, 1873, the best years of Mrs. Dodge's life have been devoted to *St. Nicholas*.

Looking back upon it from the standpoint of to-day, what a vast performance it represents! In no wise can it be measured by the size or contents of the single magazine which the post-man leaves every month at the door. It means twelve of these, each year, for more than thirty years. A complete set, in book-form, means fifty-eight large bound volumes, which would almost fill an ordinary book-case. But it means, also, such a golden treasury of stories, verses, pictures for boys and girls—such a children's library in itself—as, in the form of a single publication, can be found nowhere else in the world.

We must remember, too, that at the time when *St. Nicholas* first appeared it was such an advance upon any preceding juvenile periodical that it might justly be called an absolutely new creation. A comparison of the best issues of "The Riverside Magazine" or "Our Young Folks" with the very first number of *St. Nicholas* showed at a glance the immeasurable superiority of the new magazine. From the first, Mrs. Dodge set herself to prove the truth of her own statement—

The child's magazine must not be a milk-and-water variety of the periodical for adults. In fact, it needs to be stronger, truer, bolder, more uncompromising than the other; its cheer must be the cheer of the bird-song; it must mean freshness and heartiness, life and joy. Therefore look to it that it be strong, warm, beautiful, and true. Most children of the present attend school. Their heads are strained and taxed with the day's lessons. They do not want to be bothered nor amused nor taught nor petted. They just want to have their own way over their own magazine. They want to enter

the one place where they may come and go as they please, where they are not obliged to mind, or say "yes, ma'am" and "yes, sir,"— where, in short, they can live a brand-new, free life of their own for a little while, accepting acquaintances as they choose and turning their backs without ceremony upon what does not concern them. Of course they expect to pick up odd bits and treasures, and now and then to "drop in" familiarly at an air-castle, or step over to fairyland. A child's magazine is its playground.

Even with the opening issues, the child-readers of the country recognized that they had come into their own at last. It was the aim of both editor and publishers to produce the most beautiful and entertaining periodical for youth which it was possible to create. Mrs. Dodge was at her prime, and she made the magazine a marvel of inventiveness and youthful jollity; of absorbing stories, helpful articles, and historical sketches; of nonsense verse and genuine poetry—a rich mine, in short, of entertaining reading fitted with wonderful skill to the tastes and the wholesome development of the boys and girls. And all her conscientious labor was heartily seconded by her generous publishers. As Mrs. Dodge has said of him, Mr. Roswell Smith, the founder of the magazine, was "ambitious for the work in hand, rather than for himself. He counted no cost too great for the carrying out of a plan; and the success of *ST. NICHOLAS* has rested upon his energy and liberality." In her editorial work, also, she was fortunate in having capable and devoted assistants who shared her own enthusiasm for the magazine and its readers. The work was never drudgery to her nor to them. Her ardent zeal, keen wit, and tireless invention brightened with zest the dullest hour and the hardest task. Winter or summer, her spirits were unflagging, her powers always mettlesome and ready. Her mind teemed with ideas. Many a time, to fill a page or two in *ST. NICHOLAS*, she has written, at white heat and while the presses were waiting, contributions in prose and verse that are now household favorites in the land.

An incident connected with her editorial career on "Hearth and Home" illustrates the spirit which always animated her. A happy idea came to her that would, she knew, greatly improve the number of the paper just then going to press. But—it involved a change of many pages, the rewriting of almost the entire con-

tents of her department, and—the presses were waiting. A consultation was quickly held; the project was outlined and was promptly declared by all to be an inspiration. But could it be carried out in time? A half-hour went by in discussion; and then the decision was gently broken to Mrs. Dodge in the words: "It is impossible. We are very sorry, but it is impossible."

"Yes, I know. It *is* impossible, of course. But let's do it, just the same! Why not?" was the quick, inspiring reply; and it was done—the final enthusiastic admiration of all concerned.

What she attempted, she performed. There was no emergency, great or small, to which she was not equal; there was no Hill of Difficulty which she did not easily climb; for she believed with Emerson that "difficulties exist to be surmounted."

Perhaps it is not too much to say that with the advent of *ST. NICHOLAS* the Children's Age began. Assuredly, nothing to compare with it had ever been known before. In proof of this, let us quote from a recent issue of the New York "Evening Post" this cordial recognition of what the magazine did in those days:

In that golden era the *ST. NICHOLAS* published several of Trowbridge's best tales, "The Young Surveyor" and others of the "Jack Hazard" series; Noah Brooks's "Boy Emigrants," Miss Alcott's "Eight Cousins," and some of the wittiest and most whimsical of Frank R. Stockton's short sketches. Surely that is a noble muster-roll. Graybeards of forty will testify to the eagerness with which they awaited the mail that brought the *ST. NICHOLAS*, to the gusto with which they plunged into the fresh instalment of Trowbridge or Miss Alcott, to the earnestness with which they begged to sit up a little later that night, and to the bright, troubled dreams in which they lived over the fascinating adventures. But in a day or two the magazine had been read from cover to cover, including the alluring advertisements of bargains in foreign stamps and jig-saws; and twenty-eight long days stretched away before the next issue.

"Are n't you going to ask me to write for *ST. NICHOLAS*?" asked Mr. Rudyard Kipling, when he met Mrs. Dodge for the first time.

"I am not sure that you can! Do you think you are equal to it?" was the bantering reply, to which he quickly answered:

"Oh, but I must and shall! for my sister and I used to scramble for *ST. NICHOLAS* every month, when I was a kid."

How gloriously he redeemed his vow and earned the lasting gratitude of the *ST. NICHOLAS* editor and readers is indeed a cause of congratulation not only to the magazine but to the world. For a few weeks later, at Mrs. Dodge's home, he outlined the wonderful stories of little "Rikki-Tikki-Tavi" and "Toomai of the Elephants," and her joy may be imagined, as these were the first two of the famous "Jungle Stories" which were written especially for this magazine. The incident illustrates, however, Mrs. Dodge's editorial gift of enlisting great writers in the service of children and of getting from each of them his or her best. She had always the fitting word for every occasion, and her wide and intimate acquaintance with the greatest writers of the time was made to contribute to the benefit of the eager-minded boys and girls. It was through her personal friendship with William Cullen Bryant, Henry W. Longfellow, and John G. Whittier that those distinguished poets became frequent contributors to *ST. NICHOLAS*. But she had also the gift of inspiring all contributors with her own zeal in behalf of her beloved army of child-readers, and it was invariably in their name, and not for her own sake, that she made her appeal, as this extract from a letter to her good friend Mr. Whittier will testify:

DEAR MR. WHITTIER: I cannot help hoping that among your unwritten poems there may be some song or story for children — some Christmas thought or some personal reminiscence of a sleigh-ride or boyish coasting — in short, a legend or something from school-life, home-life, or thought-life that you may feel like giving to the children. If so, thousands upon thousands of them will be glad — and so will we editors be — and so will you be, for I know you truly enjoy making others happy.

The gentle poet responded, in due time, with a characteristic story in verse.

Even Lord Tennyson was persuaded by an irresistible letter to contribute the two exquisite child-songs which appeared in *ST. NICHOLAS* in 1880. There is little doubt that personal friendship — the authors' liking for Mrs. Dodge as well as for the magazine — helped to secure for *ST. NICHOLAS* such serials as Mrs. Frances Hodgson Burnett's "Little Lord Fauntleroy," the most popular juvenile story of its day, and

Mark Twain's "Tom Sawyer Abroad"; besides notable single contributions by leading writers, including President Roosevelt, John Hay, Bret Harte, Mrs. Oliphant, Mary E. Wilkins, W. D. Howells, Edmund Clarence Stedman, Bayard Taylor, George W. Cable, John Burroughs, Frank R. Stockton, Charles Dudley Warner, and other authors of equal reputation.

Who shall measure the benefit which she thus conferred upon the boys and girls of America and upon their parents?

But, after all, this was only the lesser part of the service which she rendered. Far greater than any contribution or set of contributions to the magazine, was the patient, ceaseless, ardent attention which the editor herself bestowed upon its pages, and the conscientious, unremitting thoroughness of her work upon it from month to month and year to year.

No mention of Mrs. Dodge's editorial life would be complete without reference to the department which was her own especial joy and pride — though, all too modestly, she never even acknowledged its authorship. What reader of the early volumes of *ST. NICHOLAS* will ever forget the famous "Jack-in-the-Pulpit," the inimitably wise and witty little preacher whose tiny discourses of the keenest sense and most inspiring nonsense — sometimes uttered from the "pulpit" direct, and at others through the blithe "Little School-ma'am" or good "Deacon Green" — were a feast for the minds and souls of young folks every month? It is no betrayal of a confidence, now, to reveal that Mrs. Dodge was herself "Jack-in-the-Pulpit," "Deacon Green," and the "Little School-ma'am" all in one. These were very actual and charming personages, however, to the boys and girls of that time. Like Shakespeare's characters to children of a larger growth, they were quite as "real" as many of the living, breathing folk whose voices we hear and whose hands we touch. There was never so delightful a department for young readers as "Jack-in-the-Pulpit," nor one so endeared by matchless wit and wisdom to every youthful heart.

As if the heavy and steadily recurring tasks of editorial work were not enough, Mrs. Dodge found time, in the intervals of her busy life, to

publish in the year 1874, her famous "Rhymes and Jingles"; in 1877, a book of essays and short stories entitled "Theophilus and Others"; and in 1879 a collection of poems and verses for grown-up readers, entitled "Along the Way."

From the first issue the success of "Rhymes and Jingles" was almost as great as that of "Hans Brinker." Their keen wit and frolicsome jollity, their cleverness and pith and point, had an irresistible charm for youngsters, who delighted in the nonsense-verses and jingles, declaring them "every bit as good as 'Mother Goose'"; while parents found many pieces useful as sermonettes for the nursery. Many a child has been shamed out of the crying habit by the story of "Whimpy, Little Whimpy" who

"cried so much one day
That his mother could n't stand it
And his father ran away."

And there are hundreds of like rhymes which are equally familiar to every ST. NICHOLAS boy or girl, for Mrs. Dodge continued to write delightful verses for the magazine long after "Rhymes and Jingles" was published as a book. Nor were they all mere clever jingles of words, or rhymes with a moral. In many of them there was genuine poetry and a fine lyric quality. The music-book "St. Nicholas Songs" gives ample evidence of this, for more than a third of all the text in the volume was written by Mrs. Dodge.

"Theophilus and Others" was a book of stories and sketches for grown people. Among its contents were a remarkably clever satire, "The Insanity of Cain," which at once attracted wide notice, and that mirth-provoking comicality in Irish dialect "Miss Maloney on the Chinese Question." This skit—well worthy to rank with Bret Harte's "Heathen Chinees"—had an enormous popularity in its day, and has since been included in almost every collection of humorous masterpieces. It was written in a single evening, to fill a blank space in a magazine. Charlotte Cushman immediately gave it a place of honor in her public readings as one of her favorite selections, and sending for its author asked her to write a companion-piece. A

long and warm friendship between the two distinguished women dated from this interview.

With her usual modesty, Mrs. Dodge would not dignify her volume of verse by the name of "poems," preferring the simple title of "Along the Way." But, as one critic said of it at the time, "It is a happy thing for those of us who do not walk such ways to have her show us what may there be seen." Only last year Mrs. Dodge was persuaded to issue a new edition of this work, under the title "Poems and Verses." Throughout, it shows sincerity of poetic feeling; a rich imagination; a genuine love of nature; and a happy serenity of heart. "Enfoldings," the sonnet on "The Stars," "Inverted," "The Two Mysteries," and not a few other pieces are poems indeed—poems that the world will not willingly let die. They have found their way already into various Anthologies of Poetry, whose editors—some of them distinguished critics—are quite willing to call them poems, even if their author was not.

In 1882 Mrs. Dodge wrote as a serial for ST. NICHOLAS her well-known "Donald and Dorothy," the narrative of a boy's chivalrous love for his sister. This was one of her favorites among her books, and it is still one of the most popular of children's stories in the book-stores and libraries. It has an original and absorbing plot and a full share of the author's rich humor. In description and character-drawing, it quite equals "Hans Brinker." So alluringly were the brother and sister depicted that in many families throughout the land there are living Donalds and Dorothys who were named after the hero and heroine of Mrs. Dodge's noble story.

In 1894 she brought out two other books: "The Land of Pluck," a collection of sketches and stories which takes its name from the opening article about Holland, and "When Life is Young," a collection of her later verses for children. The first of these ought to be read by every lover of "Hans Brinker," for it adds many new and fresh pictures of Dutch life to those which the earlier book presented; while the volume of verses opens with her well-known poem "The Minuet," and contains many other favorite pieces. Both books have won the heartiest praise from critics, and a very large audience among young readers. With "Poems

and Verses," already mentioned, these complete a list of seven books which Mrs. Dodge has published during her editorial career—truly a remarkable showing, considering the pressure and exactions of her extremely busy life. And, in addition, she compiled from the volumes of the magazine, with most conscientious care and skill, two famous nursery-books for very little folk, entitled "Baby Days" and "Baby World," which in their special field never have been equaled in merit or popularity.

The "Hans Brinker" occurrence in the



MRS. DODGE AT ABOUT THE TIME WHEN SHE BECAME EDITOR OF "ST. NICHOLAS."

Holland book-store was matched by several like incidents. During a conversation which had turned upon the many varieties of dialect in the British Isles, Mrs. Dodge once asked a distinguished general of the Civil War—a courtly, well-read gentleman of Irish ancestry—where she could find a piece of genuine and accurate Irish dialect. He replied: "Why, I happen to have one in my pocket. It is simply perfect"; and, to her astonishment, he drew forth her own "Miss Maloney on the Chinese Question."

"But you are jesting," she said. "You know who wrote that."

"No," he answered. "I clipped it from a newspaper, as you see, and the author's name is not given."

"But—I wrote it," said Mrs. Dodge.

"*You* wrote it!" exclaimed the general, in amazement. "Surely *you* are jesting!"

When she took down a copy of "Theophilus and Others" and turned to the page containing "Miss Maloney," he laughed heartily and said, with a touch of blarney: "Well, even if you did write it, it is just what you asked me for—a bit of perfect Irish dialect."

Again at a certain evening reception at Mrs. Dodge's home it chanced that a well-known singer gave as an encore a musical setting of the little poem "Snow-Flakes." After the applause had subsided, another guest said to the singer, "Your choice of 'Snow-Flakes' was a pretty compliment to Mrs. Dodge."

"In what way, please? I don't understand."

"Why, you know she wrote the words," was the reply.

"Oh, pardon me," said the singer; "the verses were written by Longfellow. See, here it is, in print, upon the music: 'Words by Henry W. Longfellow.'"

"But Mrs. Dodge wrote it, nevertheless; it is the music-publisher who is mistaken. I will show you the verses themselves in 'Along the Way.'"

Without waiting for this, the singer hurried to her hostess, and asked eagerly, "Oh, Mrs. Dodge, did you really write 'Snow-Flakes'?"

"For poor Mr. Longfellow's sake, I must confess that I did!" was the answer. "But in the latest edition of the song, I am glad to say, justice has been done to Mr. Longfellow and my name appears in place of his."

On another and a sadder occasion, Mrs. Dodge called upon a dear friend who had recently suffered a sore bereavement, and who said to her visitor, in response to a word of earnest sympathy, "I have received, to-day, a little poem which has brought me more comfort than anything else. A friend cut it from a newspaper and sent it to me"; and, to Mrs. Dodge's surprise, she began to read "The Two Mysteries." It must have been a still dearer solace for the mourner when she learned that the tender hand which was then resting upon hers had penned the poem.

A great many others have treasured and loved these consoling stanzas without knowing who wrote them. When they were originally published in October, 1876, it was the custom of magazines to print the names of the authors of contributions in the table of contents only. For this reason, no doubt, the verses were widely copied by the newspapers of the time with no name signed to them. Moreover, they have been many times credited to Walt Whitman, because of the incident narrated in the head-note in connection with that well-known poet. Of course, that incident did suggest the form and phrasing of the lines. But Walt Whitman himself and his literary executors have repeatedly corrected the mistake which ascribed it to him, and have made it clear that Mrs. Dodge, and not he, had written this inspired and lofty poem.

In her personality, Mrs. Dodge was one of the most lovely and lovable of women. There was in her face a higher quality than what the world calls beauty. As her pictures show, she had a fair and noble countenance, but the first and the most lasting impression which she made was that of a singular radiance and cheer.

Mr. Frank R. Stockton used to relate quietly, but with a twinkle of the eye, a story of his first meeting with Mrs. Dodge. From the fact that she was "a writer and editor for little folks," he had conceived an ideal of her as "a tall, spare, angular woman, very old-maidish in appearance, with a Maria Edgeworth type of face, spectacles at her eyes, and little round curls dangling in front of her ears." When, therefore, on entering her sanctum in the office of "Hearth and Home," he was greeted warmly, as he has often said, by "one of the most attractive and brilliant women he had ever seen," aglow with enthusiasm and wit, he was surprised almost to the point of embarrassment. It is needless to say that it was a fortunate meeting for both, and the beginning of a long association in which they were the happiest and heartiest of co-workers. Mr. Stockton soon joined the editorial staff of "Hearth and Home"; when Mrs. Dodge took charge of the new magazine, *St. Nicholas*, he accepted at her request the position of assistant editor, which he retained for several years;

and until the close of his life each of these two favorite writers for children had no better friend than the other.

At the varied social gatherings which she enjoyed in those days — whether in homes of affluence or in the studios of artistic and literary workers — Mrs. Dodge was eagerly sought and welcomed for her infectious gaiety, the felicitous surprises of her conversation, her sincerity, kindness, and good will. During her later years repeated illnesses lessened her activities, both social and literary, but they could not chill her joyous spirit nor her warmth of nature. Even when far from well, she could rarely forego the pleasure of welcoming her friends to her home, in one of the large apartment-buildings overlooking Central Park. Within the spacious rooms, her artistic tastes, rare sense of color, and love of elegance and refinement were reflected in the rugs and the antique furniture, the soft lights, and the family portraits on the walls. On one evening of each week, she was "at home" to a little coterie of special friends and cronies whose affection was very dear to her. She always counted upon these "little evenings," as she called them, which will be ever memorable to those who had the privilege of sharing in them. She was an ideal hostess, whose face shone with the happiness of seeing others happy. The hospitality was of the simplest. There was no formality in these friendly gatherings, but only the most homelike feeling and camaraderie. She was always their central figure, and the charm of her personality was their dominant joy. Without her, they could not have been.

A memorable chapter in Mrs. Dodge's life began with her purchase, in 1888, of a cottage in the summer colony at Onteora Park, in the Catskill Mountains. In the beginning it was a simple little square frame-house, and Mrs. Dodge took great delight in adding, year by year, a room or a veranda, a bay-window or an extension, until she created, at last, a quaint, many-gabled home, to which, each season, she joyfully returned. Nestling upon the slope of Onteora Mountain, it faced two lofty summits toward the east; while to the right stretched the beautiful blue gaps and summits of the South Range. Her cottage she named "Yarrow," from the

masses of that little wild-flower which grew close about its doors, and over the fireplace were inscribed as a motto Wordsworth's well-known lines:

"Enough if in our hearts we know
There's such a place as Yarrow."

It was a rambling, rustic home, unpretentious enough — for simplicity was always one of Mrs.

old-time friends whose cottages neighbored her own or made delightful Meccas for her in her drives about the mountain.

For Onteora had cast its spell, not only upon writers, but upon leading artists, musicians, players, and men of the first rank in their professions, who had found themselves lured to congenial association within its leafy byways. Thus, during one or another happy summer, the ve-



YARROW, COLLEGE, MRS. DODGE'S SUMMER HOME AT OUNTEORA, NEW YORK.

Dodge's chosen virtues, and simplicity reigned without and within. But she loved the cozy rooms with their quaint corners, the fire upon the hearth, and the view, from the veranda, of the green, wooded slopes and the towering blue hills beyond. Here she dwelt, summer after summer, in sweet content; in love with Nature and her little home, and yet more in love with her fellow-colonists — many of them dear and

randa of "Yarrow" echoed to merry laughter when Mark Twain, Laurence Hutton, Rev. Dr. R. Heber Newton, Carroll Beckwith, or Brander Matthews — fellow-cottagers all — dropped in, with jest or story, and found their own wits sharpened ere they left. Here, too, it was a joy to see Mrs. Dodge's unconscious pride in her elder son, James Mapes Dodge, who, not content with carrying the family genius for inven-

tion to new heights of recognition, is also a marvelous entertainer, telling stories as only he — and possibly his distinguished grandfather — could tell them. Here, again, came her neighbor, "Lady Babbie" herself, the sweet and gracious Maude Adams, with a posy of old-fashioned flowers from her own garden. Here John Burroughs, from the rustic balustrade of "Yarrow," introduced to his hostess the most unfamiliar of her other loved neighbors,—the birds,—naming each as it perched near or flitted by. Hither her most intimate and cherished friend of many years, Mrs. Lucia Gilbert Runkle, and the well-beloved Miss Sarah C. Woolsey, Mrs. Candace Wheeler, Mrs. Ruth McEnery Stuart, Mrs. Elizabeth B. Custer, brought the sunshine of their presence, and brightened her days as she had brightened theirs. And hither, during her last illness, thronged her other Onteora friends — men and women of generous and gentle hearts — with all manner of neighborly kindnesses and messages of homage and affection.

It is a consoling thought that, when the final summons came, it found her in this peaceful home, where loving hands and hearts ministered to her to the last.

The simple funeral services were held in the Onteora Church, on Wednesday, August 23d. They included the singing of the hymns "Lead, Kindly Light" and "Abide With Me." The service, read by Rev. Henry Charles Stone, the resident clergyman, was followed by the reading of Mrs. Dodge's own poem, "The Two Mysteries" — the poem that, for so many, has shed a clear light where the way was dark. For her who wrote them, the childlike faith which inspired the lines had always illumined the Valley of the Shadow. "I had to give up one of my boys," she once said, and added, in the same tender tone: "but I don't think God feels about death as we do."

A beautiful and touching tribute was offered by the children of Onteora, who preceded all that was mortal of their friend down the woodland way to the church, and, on the return of the funeral procession, carried reverently in their hands some of the floral offerings with which affection had beautified the chancel. For one of these — a great cross of yarrow — the

children had gathered the blooms; and next day, at the private interment, this cross was laid, as a fitting remembrance, upon Mrs. Dodge's grave in Evergreen Cemetery, near Elizabeth, New Jersey.

It is sad indeed to record her death in the magazine which was her life-work and her greatest pride for so many years. Her unflinching gentleness and courtesy endeared her to all those who were associated with her in her editorial tasks. Each of them remembers with tender gratitude many a special act of kindness, a word of help or warm encouragement fitly spoken; a letter of good cheer or of earnest praise. No one ever came really to know Mrs. Dodge without being better and happier for it — and the impression which she made was strengthened by closer acquaintance. As intimacy grew, so did admiration. She was always greatest to those who knew her best.

Mrs. Dodge would have been the last to claim the entire credit for the success of *ST. NICHOLAS*. Every magazine is, of course, the work of many minds and many hands. No one more promptly or willingly acknowledged how much *ST. NICHOLAS* owed to the business energy and foresight of its publishers, and to the diligence and devotion of her editorial associates. No one gave heartier recognition to the generous coöperation of its contributors and artists. The editorial authority was hers, but she trusted her assistants more and more with the actual making of the magazine; and in her later years she had, of necessity, to depend upon them more and more as she gradually withdrew from active management.

In one sense, she neither will nor can have any successor. But the work which she established and directed so ably will be continued, and will endure, a source of pleasure and of benefit to thousands, adapting itself to new conditions as they arise, and fulfilling — or even enlarging, let us hope — its mission and its influence.

To have sent out into the world a story that is a classic of juvenile literature, and unnumbered verses that have gone straight to the heart of childhood with joy and innocent laugh-

ter; to have created the best of magazines for children, and to have made it vital with the best thought and fancy of the time; to have written poems which touch the soul to a new love of beauty and a stronger faith in God — many a writer would be proud to have achieved any one of these successes. She achieved them all, and with seeming ease. But the reason is not far to seek; for what she did was merely the expression of what she was. All that she wrote and accomplished was as natural as the fruit upon the bough or the blossom on the stem. It was but the flowering of a royal nature — of noble gifts patiently and faithfully used for noble ends.

Her best memorial is already builded by her own life-work, for the volumes of *St. Nicholas* and the copies of her books that are to be found in

thousands of homes to-day will never lie dust-covered, but will continue to gladden the family life, and to inspire a love for goodness, truth, and beauty in the hearts of those who are to come after us. It is given to few to exercise so far-reaching an influence upon young minds, and thus upon the future of the nation. She left the world not only happier, but better than she found it. Few lives have been more worthy and high-minded, more useful and successful, more devoted and unselfish. Perhaps it was a part of her recompense that she retained to the last the charm of inexhaustible youth — the radiance of the morning-time of life. Through all her cares, responsibilities, and sorrows, as through all her laureled years of triumph and success, her heart was as the heart of a little child.

William Fayal Clark.

M. M. D.

MANY the laurels her bright spirit won;
 Now that through tears we read "The End,"
 The brightest leaf of all — now all is done —
 Is this: "She was the children's friend."
R. W. Gilder.

August 24, 1905

M. M. D.

LOVER of little ones
 Up to the end,
 Everywhere children now
 Mourn for their friend.

Age could not conquer her,
 Youth ne'er forsook;
 Child among children, she
 Laughed heart and book.

Long on the Lonely Road
 She 'll never roam;
 Hundreds of children will
 Welcome her home!

Josephine Daskam Bacon.

August 25, 1905.



AUTUMN—AND SPRINGTIME

From a painting by Charles C. Curran

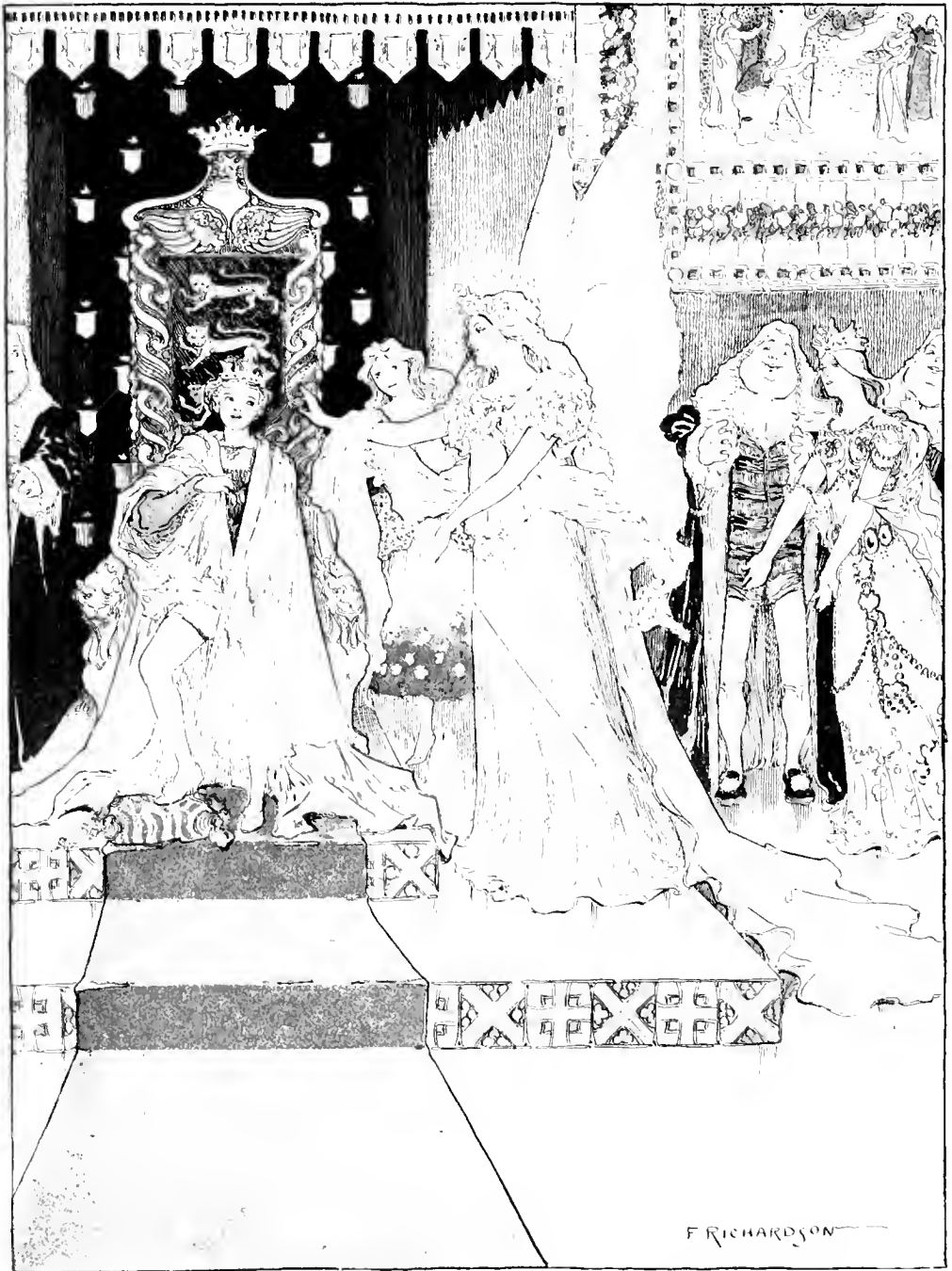

"I WISH," GRAVELY ANNOUNCED BUD, "THAT I MAY BECOME THE BEST KING THAT NOLAND HAS EVER HAD."

QUEEN ZIXI OF IX.

Copyright, 1911, by L. F. BAUM.

BY L. FRANK BAUM.

Author of "The Wizard of Oz."



"AND THE DOG RUFFLES RAN THROUGH THE
VALLEY, CRYING, 'EVERY ROLY-ROGUE HE
MEE! 'THEERY AND GET YOUR SOLE!'"

the army was ferried across, and marched up the side of the mountain that separated them from the valley of Noland. By night they had reached the summit of the mountain; but they did not climb upon the ridge, for fear they might be seen by the Roly-Rogues.

Zixi commanded them all to remain quietly behind the ridge, and they lighted no fires and spoke only in whispers.

And, although so many thousands of men lay close to the valley of Noland, not a sound came from them to warn the monsters that an enemy was near.

Thursday morning dawned bright and pleasant, and as soon as the sun was up the Roly-

CHAPTER XXIII.

THE DESTRUCTION OF THE MONSTERS.

It was Tuesday when the army of IX started upon its second march into Noland. With it were the witch-queen, King Bud, Princess Fluff, and Aunt Rivette. At evening they encamped on the bank of the river, and on Wednesday

Rogues came crowding around the palace kitchen, demanding that old Tollydob hurry the preparation of their soup. This the general did, trembling in spite of his ten feet of stature ; for if they were kept waiting the monsters would prod his flesh with their sharp thorns.

And the dog Ruffles ran through the city, crying to every Roly-Rogue he met: "Hurry and get your soup before it is all gone, for it is especially good this morning!"

So every Roly-Rogue in the valley hurried to the palace kitchen for soup. There were so



"ALL THROUGH THE CITY THE ROLY-ROGUES LAY ASLEEP."

But Tollydob did not forget to empty the contents of the Silver Vial into the soup, as the dog Ruffles had told him to do ; and soon it was being vigorously ladled out to the Roly-Rogues by Jikki, the four high counselors, and a dozen other enslaved officers of King Bud.

many that it was noon before the last were served, and these had become so impatient that they abused their slaves in a sad manner.

Yet, even while the last were eating, those who had earlier partaken of the soup lay around the palace sound asleep and snoring loudly ;

for the contents of the Silver Vial had the effect of sending all of them to sleep within an hour, and rendering them wholly unconscious for a period of ten hours.

All through the city the Roly-Rogues lay asleep; and, as they always withdrew their heads and limbs into their bodies when they slumbered, they presented a spectacle of thousands of huge balls lying motionless.

When the big kettle was finally empty and the lord high general paused to wipe the perspiration from his brow, the last of the Roly-Rogues were rolling over on their backs from the effects of the potion which the witch-queen had brewed and placed in the Silver Vial.

Aunt Rivette had been flying over the city since early morning; and although the Roly-Rogues had been too intent upon their breakfast to notice her, the old woman's sharp eyes had watched everything that took place below.

Now, when all the monsters had succumbed to the witch-potion, Aunt Rivette flew back to the mountain where the army of Ix was hidden, and carried the news to the witch-queen.

Zixi at once ordered her generals to advance, and the entire army quickly swarmed over the summit of the ridge and ran down the side of the mountain to the gates of the city.

The people, who saw that something unusual was taking place, greeted Bud and Fluff and the witch-queen with shouts of gladness; and even Aunt Rivette, when she flew down among them, was given three hearty cheers.

But there was no time for joyous demonstrations while the streets and public squares were cluttered with the sleeping bodies of the terrible Roly-Rogues. The army of Ix lost no time in carrying out their queen's instructions; and as soon as they entered the city they took the long ropes they carried and wound them fast about the round bodies of the monsters, securely fastening their heads and limbs into their forms so that they could not stick them out again.

Their enemies being thus rendered helpless, the people renewed their shouts of joy and gratitude, and eagerly assisted the soldiers of Ix in rolling all the Roly-Rogues outside the gates and to a wide ledge of the mountain.

The lord high general and all the other counselors threw away their aprons and tools

of servitude and dressed themselves in their official robes. The soldiers of Tollydob's army ran for their swords and pikes, and the women unlocked their doors and trooped into the streets of Nole for the first time since the descent of the monsters.

But the task of liberation was not yet accomplished. All the Roly-Rogues had to be rolled up the side of the mountain to the top-most ridge, and so great was the bulk of their bodies that it took five or six men to roll each one to the mountain-top; and even then they were obliged to stop frequently to rest.

But as soon as they got a Roly-Rogue to the ridge they gave it a push and sent it bounding down the other side of the mountain until it fell into the big river flowing swiftly below.

During the afternoon all the Roly-Rogues were thus dumped into the river, where they bobbed up and down in the water, spinning around and bumping against one another until the current carried them out of sight on their journey to the sea. It was rumored later that they had reached an uninhabited island where they could harm no one but themselves.

"I 'm glad they floated," said Zixi, as she stood upon the mountain ridge and watched the last of the monsters float out of sight; "for if they had sunk they would have filled up the river, there were so many of them."

It was evening when Noland at last became free from her terrible tyrants; and the citizens illuminated the entire city that they might spend the night in feasting and rejoicing over their freedom. The soldiers of Ix were embraced and made much of; and at all the feasts they were the honored guests, while the people of Noland pledged them their sincere friendship forever.

King Bud took possession of the royal palace again, and Jikki bustled about and prepared a grand banquet for the king's guests,—although the old valet grumbled a great deal because his six solemn servants would not assist in waiting upon any one but himself.

The Roly-Rogues had destroyed many things, but the servants of the palace managed to quickly clear away the rubbish and to decorate the banquet-hall handsomely.

Bud placed the beautiful witch-queen upon

his right hand and showed her great honor, for he was really very grateful for her assistance in rescuing his country from the invaders.

The feasting and dancing lasted far into the night; but when at last the people sought their beds they knew they might rest peacefully and free from care, for the Roly-Rogues had gone forever.

CHAPTER XXIV.

THE SAILORMAN'S RETURN.

NEXT day the witch-queen returned with her army to the city of IX, to await the coming of the sailorman with the necktie, and King Bud set about getting his kingdom into running order again.

The lord high purse-bearer dug up his magic purse, and Bud ordered him to pay the shop-keepers full value for everything the Roly-Rogues had destroyed. The merchants were thus enabled to make purchases of new stocks of goods; and although all travelers had for many days kept away from Noland, for fear of the monsters, caravans now flocked in vast numbers to the city of Nole with rich stores of merchandise to sell, so that soon the entire city looked like a huge bazaar.

Bud also ordered a gold piece given to the head of every family; and this did no damage to the ever-filled royal purse, while it meant riches to the poor people who had suffered so much.

Princess Fluff had carried her silver chest back to the palace of her brother, and in it lay, carefully folded, the magic cloak. Being now fearful of losing it, she warned Jikki to allow no one to enter the room in which lay the silver chest, except with her full consent, explaining to him at the same time the value of the cloak.

"And was it this cloak I wore when I wished for half a dozen servants?" asked the old valet.

"Yes," answered Fluff; "Aunt Rivette bade you return it to me, and you were so careless of it that nearly all the high counselors used it before I found it again."

"Then," said Jikki, heedless of the reproof, "will your Highness please use the cloak to rid me of these stupid servants? They are continually at my heels, waiting to serve me; and I am so busy myself serving others that those

six young men almost drive me distracted. It would n't be so bad if they would serve any one else; but they claim they are my servants alone, and refuse to wait upon even his Majesty the king."

"Sometime I will try to help you," answered Fluff; "but I shall not use the cloak again until the miller's son returns from his voyage at sea."

So Jikki was forced to wait as impatiently as the others for the sailorman, and his servants had now become such a burden upon him that he grumbled every time he looked around and saw them standing in a stiff line behind him.

Aunt Rivette again took possession of her rooms at the top of the palace; and although Bud, grateful for her courage in saving him and his sister from the Roly-Rogues, would gladly have given her handsomer apartments, the old woman preferred to be near the roof, where she could take flight into the air whenever it pleased her to go out.

With her big wings and her power to fly as a bird, she was the envy of all the old gossips she had known in the days when she worked as a laundress; and now she would often alight upon the door-step of some humble friend and tell of the wonderful adventures she had encountered.

This never failed to surround her with an admiring circle of listeners, and Aunt Rivette derived far more pleasure from her tattle than from living in a palace with her nephew the king.

The kingdom of Noland soon took on the familiar look of its former prosperity, and the Roly-Rogues were only remembered with shudders, as one remembers a nightmare, and spoken of in awed whispers.

And so the days wore away until late in the autumn, when, one morning, a mounted soldier from Queen Zixi dashed into Nole and rode furiously up to the palace gate.

"The sailorman is found!" he shouted, throwing himself from his horse and bowing low before little King Bud, who had come out to meet him.

"Good," remarked Bud.

"The Queen of IX is even now riding to your Majesty's city with a large escort surrounding the sailorman," continued the soldier.



“ALL THE ROLY-ROGUES WERE THUS ROLLED INTO THE RIVER, WHERE THEY BOBBED UP AND DOWN IN THE WATER.”

"And has he the necktie?" asked Bud, eagerly.

"He is wearing it, your Majesty," answered the man; "but he refuses to give it to any one but the Princess Fluff."

"That's all right," said the king; and, re-

which the witch-queen rode were lines of soldiers to keep the way clear of the crowding populace.

Behind the queen came the sailorman, carefully guarded by Zixi's most trusted soldiers,



F. RICHARDSON

"THE SAILORMAN IS FOUND!" HE SHOUTED.

entering the palace, he ordered Jikki to make preparations to receive the witch-queen.

When Zixi came to the city gates she found General Tollydob, in a gorgeous new uniform, waiting to escort her to the palace. The houses were gay with flags and streamers; bands were playing; and on each side of the street along

He looked uneasy at so great a reception, and rode his horse as awkwardly as a sailor might.

So the cavalcade came to the palace, which was thronged with courtiers and ladies in waiting.

Zixi and the sailorman were ushered into the great throne-room, where King Bud, wearing

his ermine robe and jeweled crown, sat gravely upon his throne, with Princess Fluff near by.

"Your Majesty," began the witch-queen, bowing prettily, "I have brought you the sailorman at last. He has just returned from his voyage, and my soldiers captured him at his mother's cottage by the mill. But he refuses to give the necktie to any one except the Princess Fluff."

out another fifty, and all were given to the sailorman.

Then the miller's son unfastened the necktie from about his collar and handed it to Fluff.



"THIS IS NOT THE NECKTIE YOUR MOTHER GAVE YOU!"

"I am the Princess Fluff," said Meg to the sailor; "and your necktie is part of my magic cloak. So please give it back to me."

The sailor shifted uneasily from one foot to the other.

"My mother told me," he finally said, "that King Bud would give me fifty gold pieces for it, and the Queen of IX would give me another fifty gold pieces, and that your Highness would give me fifty neckties."

"That is all true," returned Fluff; "so here are the fifty neckties."

Tillydib, the lord high purse-bearer, counted out fifty gold pieces, and Zixi's treasurer counted

During the murmur of satisfaction that followed, the girl unlocked her silver chest, which Jikki had brought, and drew out the magic cloak. Lifting the skirt of the garment, she attempted to fit the sailor's necktie into the place it should go; and then, while every one looked on with breathless interest, the girl lifted a white face to the sailorman and exclaimed:

"This is not the necktie your mother gave you!"

For a moment there was silence, while all present glared angrily upon the sailor. Then the king, rising from his seat, demanded:

"Are you sure, Fluff? Are you sure of that?"

"Of course I'm sure," said the girl; "it is neither the shape nor the color of the missing patch."

Bud turned to the now trembling sailor.

"Why have you tried to deceive us?" he asked sternly.

"Oh, your Majesty!" returned the man, wringing his hands miserably, "I lost the necktie in a gale at sea, for I knew nothing of its value. And when I came home my mother told me of all the gold you had offered for its return, and advised me to deceive you by wearing another necktie. She said you would never know the difference."

"Your mother is a foolish woman, as well as dishonest," answered Bud; "and you shall both be severely punished. Tellydeb."

king; and then all looked up to see the beautiful Lulca, queen of the fairies, standing beside the throne.

CHAPTER XXV.

THE FAIRY QUEEN.

EVERY eye was now fixed upon the exquisite form of the fairy queen, which shed a glorious

radiance throughout the room, and filled every heart with an awe and admiration not unmingled with fear.

"The magic cloak was woven by my hand," said the fairy, speaking so distinctly that all could hear the words; "and our object was to bring relief to suffering mortals—not to add to their worries. Some good the cloak has accomplished, I am sure; but also has it been used foolishly, and to no serious purpose. Therefore I,



"OH, YOUR MAJESTY—" SHE BEGAN EAGERLY.

he continued, addressing the lord high executioner, "take this man to prison, and see that he is fed on bread and water until further orders."

"Not so!" exclaimed a sweet voice near the

who gave the cloak, shall now take it away. The good that has been done shall remain; but the foolish wishes granted shall now be canceled." With these words, she turned and

lightly lifted the shimmering magic garment from the lap of the princess.

"One moment, please!" cried Bud, eagerly. "Cannot I have my wish? I waited until I could wish wisely, you know; and then the cloak would n't work."

With a smile, Lulea threw the cloak over the boy's shoulders.

"Wish!" said she.

"I wish," announced Bud, gravely, "that I may become the best king that Noland has ever had!"

"Your wish is granted," returned the fairy, sweetly; "and it shall be the last wish fulfilled through the magic cloak."

But now Zixi rushed forward and threw herself upon her knees before the fairy.

"Oh, your Majesty—" she began eagerly; but Lulea instantly silenced her with an abrupt gesture.

"Plead not to me, Queen of Ix!" said the dainty immortal, drawing back from Zixi's prostrate form. "You know that we fairies do not approve of witchcraft. However long your arts may permit you to live, you must always beware a mirror!"

Zixi gave a sob and buried her pretty face in her hands; and it was Fluff whose tender heart prompted her to raise the witch-queen and try to comfort her.

For a moment all present had looked at Zixi. When their eyes again sought the form of the fairy, Lulea had vanished, and with her disappeared forever from Noland the magic cloak.

Some important changes had been wrought through the visit of the fairy. Jikki's six servants were gone, to the old valet's great delight. The ten-foot general had shrunken to six feet in height, Lulea having generously refrained from reducing old Tollydob to his former short stature. Ruffles, to the grief of the lord high steward, could no longer talk; but Tallydab comforted himself with the knowledge that his dog could at least understand every word addressed to him. The lord high executioner found he could no longer reach farther than other men; but the royal purse of old Tillydib remained ever filled, which assured the future prosperity of the kingdom of Noland.

As for Zixi, she soon became reconciled to her fate, and returned to Ix to govern her country with her former liberality and justice.

The last wish granted by the magic cloak was doubtless the most beneficial and far-reaching of all; for King Bud ruled many years with exceeding wisdom and gentleness, and was greatly beloved by each and every one of his admiring subjects.

The cheerfulness and sweet disposition of Princess Fluff became renowned throughout the world, and when she grew to womanhood many brave and handsome princes from other countries came to Nole to sue for her heart and hand. One of these she married, and reigned as queen of a great nation in after years, winning quite as much love and respect from her people as his loyal subjects bestowed upon her famous brother, King Bud of Noland.

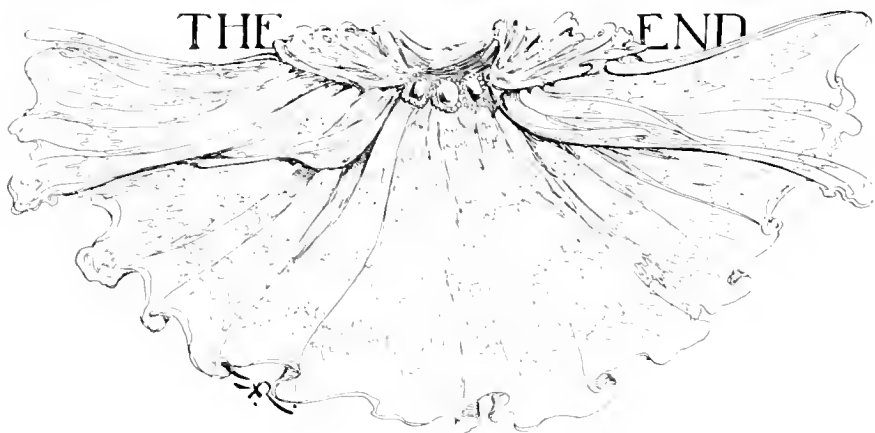

THE LITTLE GOOD SAMARITAN AND



THE TALL, TALL LOAF.

BY MEREDITH NUGENT.

EVERYBODY was dodging first to the right, then to the left,—and finally a man's hat was knocked off. The crowds streaming out of old Notre Dame rendered it difficult to approach nearer the excitable hands and heads, although it was plainly to be seen that a tall loaf of bread alternately disappearing and bobbing into view was the cause of the merriment. Hats were tilted sidewise, chins were tipped upward, people backed upon one another's toes, pressed forward upon one another's heels, laughed, gesticu-

lated, became angry, and laughed again. In the midst of this whirlpool of jostling humanity was a cleared space of goodly circumference, in the center of which I beheld a little American miss, carrying the tallest loaf of bread I ever saw. Had she been a little Parisian and used to such burdens, she would have known that to turn about in so great a throng meant that the top end of that loaf would surely bump into somebody; that is, if she had carried it across her shoulder, as did Gladys. But she was

plainly quite unconscious that she was causing a commotion; and thus it came to pass that this particular loaf of bread swung around like an over-sensitive wind-vane and distributed bumps north, east, south, and west in reckless profusion. Of course everybody laughed, for all the victims were polite and good-natured, and besides, the "petite" excused herself so prettily in French that some of the most amused onlookers feigned to be hit when they actually were not. But when Gladys turned to ask pardon of a woman who clapped her hands to her hat and cried "Oh!" the far end of the loaf would whirl in front of a Frenchman's eyes, and he would cry "Ah!" And when she wheeled about to ask pardon of this Frenchman who cried "Ah!" that same crusty end would swing perilously near as many hats and chins as it could possibly encounter in half a circle. Indeed, there is no telling how the "petite" ever would have caught up with her list of excuses had I not recognized my little countrywoman and rescued her and the bread from further difficulties.

"Oh, is it *you*? I am so glad!" was her hearty greeting. "And, oh, *now* I need n't go back home for Marie, for you will take her place, and go with me—won't you, please? It is only a little way from here."

I cheerfully consented to serve as nurse and guardian for the "little way"; and as we both hurried from the cathedral swarms, toward the narrow streets on the other side of the river,—and we hurried to keep warm, for it was an extremely cold morning,—Gladys confided to me her secret, which up to that time she had not mentioned to any one.

It seems that, on the day before, a tiny

French girl had posed in her father's studio, and that after the child had left for her home Gladys inquired why it was that all little girls do not have round, plump, rosy cheeks like her own. For the first time Gladys learned that all little girls do not have the nourishing food which helps to make round, plump, rosy cheeks. This explanation set her little brain to thinking, and reminded her of a "tall, tall loaf" of bread which she had seen freshly displayed that very afternoon. It was in the window of a bakery just across the square from the great cathedral, and only three blocks distant from her father's studio. So, the next morning immediately after breakfast she had started out and bought the "tall, tall loaf." It was while burdened with this great length of bread that I discovered her in front of Notre Dame, and then I carried the loaf for her to the dingy quarters we were soon entering. After a breathless climb up two dark flights of stairs, the little model who had posed on the previous day responded to our knocking, and Gladys handed her the bread and said something in French to her mother, which I fancy must have referred to round, plump, rosy cheeks, for the woman lifted the corner of a shawl to her eyes as though wiping away tears.

It is a common sight in Paris to see working-people carrying long loaves of bread, but this one that Gladys purchased was the longest I ever saw, and must certainly have measured six feet in length.

I thought of Gladys and her generous errand that night, as I looked from my own studio-window across to the great snow-covered roof of Notre Dame gleaming cold under the wintry stars.



THE

GUNNERS.

BY
C. M. C. R.



Four gunners, marching over the hill
With guns and dogs, all ready to kill.
Three foxes, scampering over the lea—
I wonder if they will see!
O, bird! flying above in the blue,
Can't you see the gunners are looking at you?
And little red foxes, down on the plain,
Run! or you ne'er may run again!
The gunners are taking aim.—
Four loud bangs! Four dogs run!
Each man lowers a deadly gun.
Alas! what mischief have they done?



The bird sails on, high above in the blue.—
Oh, gunners!! the foxes are laughing at you—
And we are, too.



PINKEY PERKINS: JUST A BOY.

BY CAPTAIN HAROLD HAMMOND, U. S. A.

IX. HOW PINKEY TREATED THE PUBLIC.

PINKEY PERKINS was hurrying from school to the Opera-house. The "Colson Comedy Company" had arrived in town that afternoon, to remain two days, and Pinkey felt his services might be in demand.

"What you a-hurryin' so for, Pinkey?" puffed Bunny Morris, coming up behind him on a run.

"Goin' to get a job peddlin' bills for the show t'-night. Come on!" and Pinkey broke into a run, followed by the ever-faithful Bunny.

Arrived at the Opera-house, Pinkey, as spokesman for the pair, made their desires known to the manager, who informed them that there were four boys already distributing bills, and their services were not needed.

Undaunted by this disappointment, Pinkey asked if there was "anything else they could do to get in." The manager replied that there was not, and told them not to "pester" him any more.

But they would not leave. They remained on the stage, offering a helping hand here and there, and getting in the way generally, hoping that by remaining present and in evidence they might be of enough assistance to gain the coveted "Pass this boy" for the evening's performance. If the passes were forthcoming, they hoped to obtain later the necessary permission from home.

The stage was finally set, and everything was in readiness for the play that night. Pinkey and Bunny contrived to keep within the manager's notice, that he might not overlook them and make it necessary to ask him for passes. Their manœuvres availing them nothing, Pinkey finally mustered up courage enough to say to the manager: "Bunny Morris 'n' me could come to the show t'-night if we had a pass."

"You have n't done anything to earn a

pass," replied the manager, getting vexed; "now run away and don't bother any more."

"We 've worked, helpin' shift scenery," persisted Pinkey, unwilling to give up.

Then a new thought flashed through the manager's mind. Here was a chance to have some fun at the boys' expense.

"If you kids want to see the show to-night," said he, "you can go on the stage and take parts. We were going to leave out two characters, but you can help us make the cast complete."

The two boys exchanged glances. Could it be that at last they were to have their one ambition realized, that they were to become real actors?

The other members of the company assembled in the wings to witness the fun.

"Were you ever on the stage before?" queried the manager, critically.

Pinkey said he had delivered the "Welcome Address" at the church on "Children's Day," and Bunny said he had sung in the chorus on the same occasion.

"Oh, well, then," said the manager, winking at one of the actors, "you'll both do excellently—you're just the boys we want. Now we'll have to rehearse, so that you can get your lines for to-night."

So saying, he called Pinkey and Bunny to the center of the stage and explained the situation to them.

"Now remember," said he, "you are two brothers who, in your youth, separated to seek your fortunes. You have not seen each other for twenty-two years. You"—indicating Pinkey—"have been in prison all that time for a crime you did not commit, and you"—indicating Bunny—"have searched the world over all these years to find your brother." Both boys were too intent on their parts to notice the dis-

crepancy between their actual and their supposed ages.

Finally, after further detailed instructions, they began to rehearse. With serious faces and tragic strides, they repeatedly met in the middle of the stage and went through their act.

"Ah!" exclaimed Bunny, "methinks I see a familiar look in those eyes. Dost know me, stranger?"

"Nay, nay, friend," replies Pinkey, solemnly, "I know thee not. For twenty-two long years have I lived behind a dungeon's bars, an innocent man."

"Ah, ha!" cries Bunny; "I thought it—I thought it! Hast thou a strawberry-mark on thy left shoulder?"

"I haive," says the realistic Pinkey, in a very dramatic way, to the convulsive delight of the onlookers.

"Then thou art my own long-lost brother!" shouts Bunny, endeavoring to clasp the doubting Pinkey in a fond embrace.

Pinkey holds him at arm's length. "Come not near me. I call no man 'brother' until he sing to me a lay of our childhood. — Ah, that voice!"

Whereupon Bunny bursts forth with the words of the "Welcome Carol" he had joined in singing on "Children's Day." This satisfies the skeptical Pinkey, and the two rush headlong into each other's arms.

Here the curtain was supposed to fall.

Time after time did they rehearse, until the manager told them they did beautifully. Then they hurried proudly away under instructions to return in time to go through their parts a few more times before the curtain went up.

On the way home, after discussing the matter with Bunny, Pinkey decided that in order to make his portrayal of the character of ex-convict all the more realistic, he should have his hair clipped short. For a long time he had nourished an unquenchable desire to have his hair clipped, but never could he obtain parental sanction to his longing. But he felt



"'THEN THOU ART MY LONG-LOST BROTHER,' SHOUTS BUNNY, ENDEAVORING TO CLASP THE DOUBTING PINKEY IN A FOND EMBRACE."

that there could be no objection when it was done in the cause of "the Drama."

Pinkey knew a boy who was learning the barber's trade and was in the habit of cutting hair free of charge, and to him he went to be shorn.

Bursting with importance, Pinkey hurried home from the barber shop to acquaint his mother with his new stroke of fortune, and to urge the necessity of returning to rehearse again immediately after supper.

His elation was short-lived. The greeting he received, as he entered the sitting-room, was far from reassuring.

"Pinkerton Perkins," gasped his mother, "what *have* you been up to now, and who cut your hair?"

"I 'm goin' to act in the show at the Opera-house t'-night, 'n' I 'm to be a convict, so I got my hair clipped, to look like a convict."

Mrs. Perkins could not find suitable words to express her feelings in the matter, so she remanded Pinkey to his room, to await his father's arrival. No amount of explanation or persuasion on Pinkey's part could bring his mother to take his view of the proceeding.

"They can't *have* the show without me and Bunny," he pleaded as his final argument.

"You 'll have show enough when your father comes home," warned the mother; "the *i-d-e-a* of you getting your head shaved!"

Heavy-hearted and apprehensive, mumbling something about "not shaved, only clipped," Pinkey went up to his room and sat down on his bed to await developments. His stage career seemed blighted before it had even begun, and the outlook that had been so rosy now chilled him with its bleakness. He knew a punishment awaited him when his father came home. He also knew that for him no curtain would rise and no footlights glare *that* night. He looked in his mirror and again dreaded the meeting with his father. Oh, that hair could be grown as fast as it could be removed!

Half an hour later, Pinkey heard unmistakable footfalls on the sidewalk, and in a few moments the word "Pinkerton!" coming from below smote his ear with boding emphasis. Slowly and deliberately, his hat pulled down tight on his head, he descended the stairs and confronted his father.

"Take off your hat and let me see your head," demanded the father. Pinkey silently uncovered his bristling head and waited.

"Who told you you might have that done?" asked the father, with difficulty concealing a smile.

"Nobody. I was to be a convict in the show t'-night, and I had Johnny Fox cut my hair like one. He did it for nothing."

"You 'll be a convict here to-night, if I 'm not mistaken—come with me." And Pinkey reluctantly followed his father to the woodshed.

Mr. Perkins was hardly in the proper frame of mind to discipline his son; but disobedience could not be winked at, even when to Pinkey the circumstances seemed to warrant it. With a slender switch, chosen more for moral effect than for real punishment, he began his unpleasant duty. Instantly he was aware that all was not right. In the dim light of the woodshed he had failed to detect an unusual bulkiness in certain portions of Pinkey's anatomy, which, had he noticed it, would have created suspicion in his mind.

"Pinkerton," he demanded, "what have you got in your trousers?"

"'Tribunes,' sir," faltered Pinkey, much chagrined at being found out, and fearful of the consequences. While upstairs, waiting for his father to come home, he had lined the more exposed parts of his clothing with accumulated daily papers, as a guard against the stings of the coming punishment.

Parental dignity was all that saved Mr. Perkins from compromising his rôle of stern father. With difficulty did he control himself long enough to order Pinkey to the house and to bed immediately. Then, as Pinkey made a hasty exit, his father, unable to retain his composure, gave way to the laughter that was consuming him.

Pinkey did not know that the supper which he ate in bed that night, instead of being smuggled to him by the hired girl, as he supposed, had been authorized by a lenient father and prepared by a generous mother.

At breakfast the next morning, Pinkey was unusually quiet. He felt much better when it was over and the subjects of show, hair, and "Tribunes" had not been touched upon, for this told him that those pages had been turned and that he was starting anew once more.

As he went to school, he grew very much elated over the envy he inspired, and jealous ones were allowed to run their hands over his head backwards, or "against the grain."

"Tell you what, you fellers don't know how nice 'n' cool it is, either," he said patronizingly

to the long-haired ones; "an' you don't have to be combin' it all the time."

In front of the Post-office he met Bunny, and while strolling schoolward he proceeded to question him about the show. Bunny was

were gettin' in on last night, just ezactly. They're sellin' tickets in here,"—indicating the corner drug-store,— "let 's look and see for certain."

The two boys went into the store, and there in the show-case they saw a pile of tickets, upon each of which was printed in "job-type," with a border:



"PINKEY SILENTLY UNCOVERED HIS BRISTLING HEAD AND WAITED."

very reticent, but finally he admitted that he had attempted to obtain recognition at the Opera-house the night before and had failed. He said the man just asked him if he had a strawberry-mark on his left shoulder, and then laughed and told him to clear out.

"But say, Pinkey," he confided, "you remember those tickets we found in the ticket-office last fall, after that home-talent show? We were a-goin' to use 'em for tickets to our circus, you know. Well, they're just the same as people



They were exactly the same as the ones Pinkey had at home, being examples of the typographical limit beyond which the "Citizen" office dared not venture.

"Bet you we go to that show t'-night," said Pinkey, knowingly. "I've got all those tickets yet, an' as the show-people would n't get any money out o' us, anyway, there 's no harm in usin' 'em."

"You bet," agreed Bunny; "an' they said they 'd let us in last night, too."

At noon, when Pinkey asked if he might go to the show that night in case he and Bunny could get in free, he was actually disappointed when he was informed that his father had been presented with three tickets that morning, and would take him and Bunny if they wanted to go so badly, but that there would be no more "acting" indulged in by them.

When Pinkey saw that he had lost his opportunity to use his own tickets, he evolved another scheme, on a much grander scale, which scheme he proceeded to perfect during the afternoon.

When school was out, he laid his plans before Bunny, who, as usual, bent his ideas to suit Pinkey's. In accordance with the course they had mapped out, they made all possible haste to reach the Opera-house in time to get the employment they had sought the day before. The manager was surprised to see them

again after their previous experience, and admired their persistence when they told him why they had come a second time.

Much to their delight, they were successful in their endeavors, and each was soon armed with a large pile of handbills for distribution. As soon as they had left the Opera-house, Pinkey turned his bills over to Bunny, agreeing to meet him ten minutes later, down by the woolen-mill. Hurrying home by the back way, he stealthily entered the house, secured his tickets, and was out again and gone before his presence was discovered. At the appointed time he effected the meeting with Bunny, and forthwith the two boys began a house-to-house distribution, both of handbills advertising a performance of "The Silver King," and of complimentary tickets to the same. Boldly they distributed their tickets over that quarter of the town where lived a class of people to whom the theater was an unknown luxury. Women whose husbands were in the mine, and whose children were still at their looms in the factory, were made glad by receiving a ticket for every one in the family.

By supper-time Pinkey and Bunny had distributed over two hundred tickets, merely saying as they hurried from house to house: "Here's some bills we're distributing for the show to-night, and some complimentary tickets, so 's they 'll be sure and have a good house."

When they had exhausted their supply of tickets, they went to another part of town and finished distributing their bills.

"Tell you what," said Pinkey, as the pair was returning to the Opera-house for the unnecessary passes, "those people were glad to get the tickets, were n't they, Bunny? And when that man who made us act the monkey yesterday sees all these people, and then counts the money he gets from the drug-store, he 'll be about as mad as they are glad. There 's nothing wrong in it, either, 'cause none o' the people we gave tickets to could afford to buy tickets."

"You bet," echoed Bunny; "he won't lose nothin', 'cept in his mind; but he 'll think he 's made a lot he never gits. I guess we 'll fool him as bad t'-night as he did us yesterday."

On their way home they gave away their

passes to a couple of older boys whom they knew slightly, thereby winning allegiance which might sometime be useful.

As Pinkey, the image of propriety, sat between his father and Bunny that evening and watched the crowd pour into the Opera-house, he actually became alarmed at the enormity of his afternoon's doings. He wondered what could be done with him and Bunny. Could they be arrested? What if some one should be refused admittance and tell on them! By the time the play began, Pinkey and Bunny were both genuinely frightened. But when the people were all in and the curtain rose, they regained their composure and became intensely interested in the play.

During the intermission between the third and fourth acts, Pinkey noticed a commotion at the door. He saw the druggist come in, much excited, followed by the doorkeeper, with his hands full of tickets, and both rush hurriedly up to the stage-door and disappear. A few minutes later they returned and went outside again, accompanied by "the Silver King," ordinarily the manager, and the villain, who, before the play began, had sold tickets in the little office near the door. When the curtain had fallen a few minutes before, he was languishing in chains, but now he appeared surprisingly alert.

There was trouble somewhere, and Pinkey knew that he was responsible. Bunny was scared too, and looked appealingly at Pinkey, whom he trusted to get him safely out of it. Presently the Silver King and the villain returned, looking much perplexed, and, greatly to the peace of mind of the two boys, the play proceeded.

During the fourth act the doorkeeper and the druggist came in again, and the latter went to a couple of men in the audience and whispered something to them. One of the men whispered something in reply, and then all three looked toward Pinkey, and Pinkey unconsciously edged closer to his father. Then he saw the druggist nod in his direction while talking to the doorkeeper.

When the druggist pointed out the two boys as the parties responsible for the packed house, the doorkeeper instantly recognized them.

He went up on the stage and told the Silver King about what he had learned, and asked him what was to be done.

The manager said it was too late to do anything. The people were there, and the play was nearly over. They could not collect admission fees now, and the play must be finished on account of those who had paid.

What puzzled every one was where the boys got all their tickets. The druggist could account for all he had had; and besides, they now had on hand two hundred more than had been printed. After thinking it all over, the manager decided that there was nothing for him to do but make the best of the situation and take it philosophically.

When the play was over Pinkey and Bunny, each holding one of Mr. Perkins's hands in a nervous grasp, felt their hearts sink as they saw the manager, the doorkeeper, and the druggist all waiting for them at the door. As they reached the opening, the manager stopped them, saying:

"Well, you boys scored one on all of us this time, and I can't blame you very much. But where on earth did you get all those tickets?"

Pinkey and Bunny were reluctant about talking before Pinkey's father; but after the druggist had told him of their two-edged generosity that afternoon, they felt reassured. They told of getting the tickets the fall before, of the failure of their circus to materialize, and of

their using them that day to give a lot of poor people a chance to see the play, as well as to raise the manager's hopes, as he had theirs the day before, and then allow him to suffer corresponding disappointment. No one attached any



"AS THEY REACHED THE OPENING THE MANAGER STOPPED THEM."

real blame to the boys for their action, though the manager admitted it was a severe blow to him to have the receipts he had counted upon from the "whopping big house" cut in half.

As they left the hall Pinkey and Bunny were still doubtful that all danger was passed. Next morning, however, the train bearing the "Colson Comedy Company" departed, and they felt secure from further trouble.

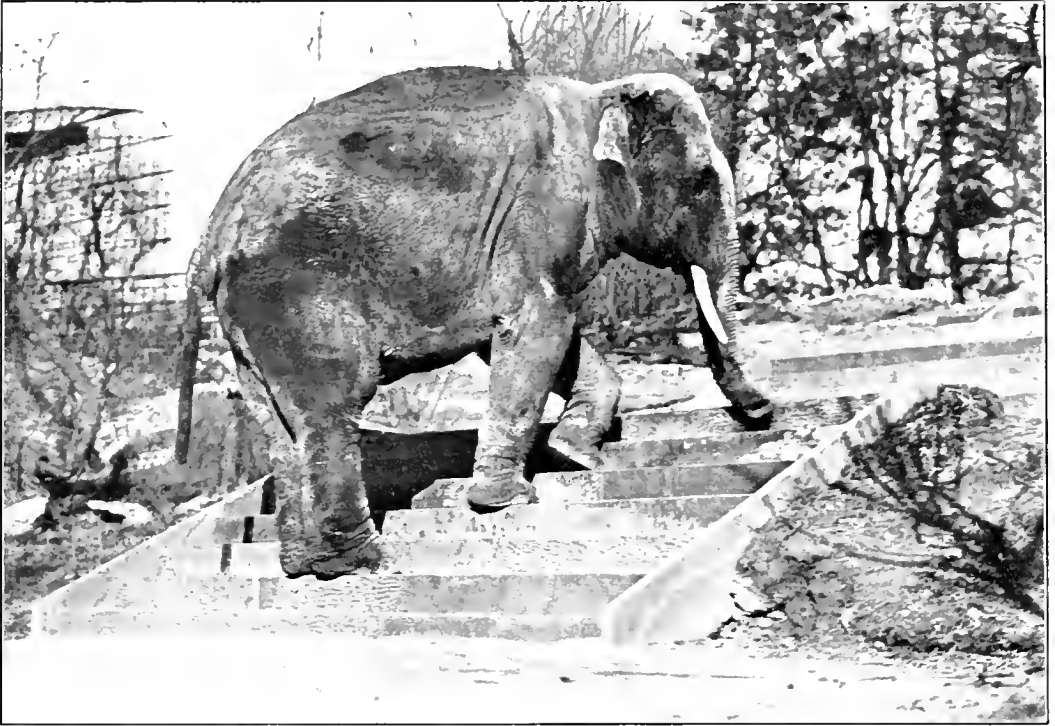

GUNDA GOING TO BREAKFAST.

GUNDA.

BY HELEN D. VAN EATON.

THEIR firmness and kindness combined will easily govern many wild animals that by nature are fierce and unruly, finds a notable illustration in Gunda, the young elephant which daily amuses hundreds of youngsters at the Bronx Zoölogical Gardens in New York City. Gunda was captured wild in an Indian jungle, just a little over a year ago, and purchased for the Zoölogical Gardens by Hagenbeck, the famous animal trainer whose Zoo is one of the wonders of Berlin. He was shipped in care of an Indian keeper, Hassan Bey by name, as it was supposed that the young elephant would be far less lonesome when attended from the beginning of his captivity by a native with whom he was familiar.

Gunda was brought over in a strong crate,

and finally lodged in the elephant quarters. From the moment he was taken from the crate Gunda was sullen, fierce, wickedly inclined, and considered dangerous. Hassan Bey took little interest in his charge, and finally became so indifferent—spending most of his time sighing for his far-away home—that Director Hornaday discharged him, with the gift of a steamship ticket, and sent him back to Ceylon.

Hassan Bey had remained only a month, and during that time Gunda's only mission in life seemed to be the destruction of everything within reach of his trunk. He wrecked his stall, threatened his keeper, and gave many evidences of being a genuinely bad elephant, like Central Park Tom and others who became murderers and met a murderer's fate. But at

the earnest request of young Frank Gleason, Gunda was placed in his charge the day Has-san Bey took his leave, and a marvelous transformation began at once. Gleason, who is only twenty-eight, has spent most of his life among wild animals, principally elephants, and has the natural love for his beasts that is the first requisite of a successful trainer. He had watched Gunda from the day of his arrival, and had been thoroughly convinced that the

purchased for the mission he is now fulfilling, that of carrying people on his back about the park. Gleason took charge of him at a time when the powers higher up had about decided he should go the way of all bad elephants. He told Director Hornaday he would have Gunda safe and ready for work inside of a week, but his confidence only excited good-natured raillery and a statement that if he had Gunda tamed in two months it would be highly satisfactory.



GUNDA'S HOME AT THE ZOO.

whole trouble was due to the native Indian keeper, whom Gunda did not really like.

"Gunda's heart is in the right place, and I think I am the boy to reach it," young Gleason told Director Hornaday. His appeal was so earnest that Dr. Hornaday, somewhat against his own better judgment, finally decided to give Gleason a chance. Originally, Gunda was

The young keeper believed in himself and believed in Gunda. Director Hornaday was astonished when, two days after Gleason had taken charge, he appeared astride of the elephant in front of the Director's office and announced that Gunda was "good" and ready for business. The wicked young elephant had become not only good, but really obedient, for

he obeyed Gleason's commands with an accuracy and willingness that made the Bronx officials marvel. Within a week Gunda was ambling about the park loaded down with gleeful children, and getting just as much fun out of it all as the youngsters on his back.

Now he is as gentle and lovable as one could wish, and the especial pet of the children who flock to the park during the spring and summer months. It costs fifteen cents to ride on Gunda's back, and, generally speaking, there are not a great many youngsters of those

the sight of a little dog, while the sight of a donkey or horse would almost give him a fit. Now he is not even afraid of the largest and fiercest-looking automobile. He climbs over fences, calls on the other animals quartered in his neighborhood, plays with any dog that comes along, and allows the children to pull his ears and pat his sides to their hearts' content.

Gunda's best friends, with the exception of his keeper, are Mr. and Mrs. Schwarz, of the Rocking Stone Restaurant, where Schwarz is chef and his wife assistant. The chef knows



"TAKING" A FENCE.

who visit Bronx Park who can spare fifteen cents for an elephant-ride. But all are allowed to feed him peanuts and sweetmeats, and Gunda has grown fat and good-natured on the generous morsels he has received from his young friends.

When the young elephant came to the park, he behaved like a frightened child when first taken out of his stall into the highways and byways. He would stand and tremble all over at

what tidbits Gunda likes best, and always has a supply waiting when the elephant ascends the steps leading to the restaurant and thrusts his trunk through the kitchen door or kneels down at Gleason's bidding and "begs" for his breakfast. Gunda calls at the restaurant daily.

Gunda has the greatest faith and confidence in his young master, and no terrace is too high for him to climb at Gleason's bidding. He has made rapid progress in the English lan-



GUNDA BEGGING.

guage and understands many words. Besides being an unusually intelligent elephant, Gunda promises to become a monster of his kind. Elephants grow until they are past thirty, and Gunda is only eight. When he reached the Zoo he weighed 3,740 pounds, and in March

he weighed 4,107, a gain of nearly 700 pounds in a year. In the same time his height increased from six feet seven inches to six feet eleven and a half inches. His tusks are nineteen inches long, and are said to be the finest that any captive elephant of his age can boast.

THE BABY MOON.

BY ANNA H. BRANCH.

I saw the little baby moon last night;
 It nestled in the sky, as if to sleep,
 Cuddled among soft clouds, to left and right,
 And, close beside, one star a watch did
 keep.
 "Good night, you little baby moon," said I;
 "Good night, and go to sleep."

I saw it still and safe and tranquil there,
 Cradled in that blue distance of the night.
 It made me smile with joy, it was so fair
 So beautiful, so childlike and so white.
 "You dear sky sleeper," looking up, said I,
 "Good night, you little baby moon; good
 night."

HOW TO STUDY PICTURES.

BY CHARLES H. CAFFIN.

A series of articles for the elder girls and boys who read "St. Nicholas."

TWELFTH PAPER.

COMPARING WHISTLER WITH SARGENT.



WHISTLER'S PORTRAIT OF HIS MOTHER FROM A PHOTOGRAPH BY BRAUN, CLÉMENT & CO.

JAMES ABBOTT McNEILL WHISTLER (BORN 1834,
DIED 1903); JOHN SINGER SARGENT
(BORN 1856).

THE two pictures here shown, like the artists who painted them, present a strange contrast.

The work of both these men has an original force that has influenced countless other painters. Both owe much to the influence of Velasquez; Sargent also to that of Franz Hals, while Whis-

ter gleaned from the French painter Manet and the Japanese. The originality of each consists in adapting what he has derived to the spirit of his own age and surroundings, and in giving his own work an independent life that has become, as I have said, an example to others.

Now that we are reaching the end of our survey of painting, we may look back and see that the progress has been for the most part a series of renewals, of men carrying forward and

farther what they had received from others. The most notable example of this in the whole story is that of Raphael, who has been called "the Prince of Borrowers," and yet his work is unique. It is not the search after or discovery of new ideas that makes an original man, so much as his ability to reclothe the

Florence, combining the charm of sky and hills with the wonders of art in the galleries and the advantages of intellectual and artistic society. Accordingly, when Sargent arrived in Paris he was not only a skilful draftsman and painter, the result of his study of the Italian masters, but also,—which has had perhaps an even



THE MISSES HUNTER. FROM A PORTRAIT BY JOHN S. SARGENT.

old with some newness of meaning out of his own ideas.

When Sargent entered the school of Carolus-Duran he was much above the average of pupils in attainment. He had been born in Florence in 1856, the son of cultivated parents; his father, a Massachusetts gentleman, having practised medicine in Philadelphia and retired. The home life was filled with refinement, and outside of it were the beautiful influences of

greater influence upon his career,—young as he was, he already had a refined and cultivated taste. This at once stood him in good stead, for his new master, Carolus-Duran, though a very skilful painter and excellent teacher, was otherwise a man of rather showy and shallow qualities. He, too, had studied in Italy, but later in Spain, and it was chiefly upon the lessons learned from Velasquez that he had founded his own brilliant method. This method Sar-

gent, being a youth of remarkable diligence with an unusual faculty for receiving impressions, soon absorbed. He painted a portrait of his master which proved he had already acquired all that the latter could give him. Then he went to Madrid and saw the work of Velasquez with his own eyes; and later, he visited Holland, where he was greatly impressed with the portraits by Franz Hals. Let us see how these various influences are reflected in his work.

In the picture on page 1095 we may trace the influence of Velasquez in the noble simplicity of the lines, in the strong impression which the whole composition makes, and the quiet elegance obtained by the treatment of the black and white costumes. Moreover, the whole picture has the high-bred feeling and stateliness of manner, the powerful directness and yet dignity, that Sargent found in the old Italian portraits. Yet the spirit of the picture is thoroughly modern; not only do the ladies belong to to-day, and vibrate with life, but there is life in the very brushwork: now a long sweep of a full brush, now a spot of accent, a touch-and-go method, brilliant, terse, quick, and to the point, qualities that are best summed up in the French word *esprit*. They are peculiarly French; and in his possession of them Sargent shows the influence of his training and life in Paris, and proves himself a modern of the moderns.

Yet in his case this *esprit* is rarely carried to excess; and when it may seem to be, as in some of his portraits of ladies, one may guess that he took refuge in this spectacular display of brushwork because he could find nothing else in the picture to interest him. Usually, he seems to have received an almost instantaneous impression of his subject, vivid and distinct, to the setting down of which are directed all his later efforts; and they are often long and patiently repeated. It is not a deep impression; as a rule, it takes little account of the inward man or woman, but it represents with amazing reality the outward person.

From Franz Hals, Sargent caught the skill of modeling the faces in a quiet, even light, of building them up by placing side by side firm, strong patches of color, each of which contains exactly the right amount of light, and of giving

to flat masses of color the suggestion of roundness and modeling. While French *esprit* is noticeable in his portraits of women, his portraits of men recall rather the manly force of the old Dutch painter.

In addition to portraits, Sargent has executed wall decorations for the Boston Public Library, the theme of which is the "Triumph of Religion," illustrating certain stages of Jewish and Christian history. And in the frieze below stand the "Prophets" of the Old Testament, large and simple forms, following one another in beautiful lines, simple and dignified. Upon the wall at the opposite end of the room appears a representation of the "Redemption of Man," treated in the spirit of Byzantine decoration, but without the Byzantine unnaturalness in the drawing of the figures (which was explained, you remember, in the first article of this series). This panel, the latest executed, is the best, being a remarkable example of combining the style of modern painting with that of the old Byzantine decoration.

These decorations exhibit a very beautiful side of Sargent's mind that has been only partially developed: a deeper insight into the meaning of the subject than his portraits suggest. The latter are distinguished rather by a boldness of method and an extraordinary appreciation of the value of the things which lie upon, or only a little below, the surface. In this respect he offers a great contrast to Whistler.

If you turn to the latter's "Portrait of the Artist's Mother," you will recognize at once that the word "boldness" cannot be applied to it; also, that the interest it arouses is a much deeper one than you feel in Sargent's picture. For Whistler, not a brilliant brushman, was interested most in what could not be presented to actual sight, but suggested only. Here it is the tenderness and dignity of motherhood and the reverence that one feels for it: not the first blossoming of motherhood, as in Raphael's Madonnas, but the ripened form of it; what the man himself is conscious of owing to it and feeling for it; what the mother herself may feel, as she looks back with traveling gaze along the path of hopes and fears, of joy and pain, that she has trodden. This miracle of Motherhood,

most holy and lovely of all the many miracles of life, continually repeated in millions of experiences, Whistler has represented once for all in such a way that this picture will remain forever a type of it.

At one period of his career Whistler almost completely discarded form and drawing, relying, as far as possible, entirely upon the effects of color to produce the impression; calling these canvases, in which different tones of one or more colors would be blended, "nocturnes," "symphonies," "harmonies": terms borrowed from the art of music. The public, being used to names and to being interested in practical things, asked, "What are they all about?" and, receiving no answer, scoffed.

But even to Whistler these canvases were only in the nature of experiments. The pictorial artist cannot get away from objects which we can see and touch; they must engage his attention. Let us see how Whistler managed this, interrupting for a moment our study of his paintings by a glance at his work in etching, for all through his career he was etcher as well as painter. Among his early etchings is a series of views of the Thames: the row of picturesque old houses that lined the water at Chelsea, where he lived for many years, the wharves, the shipping, boat-houses, and bridges. These etchings are marvelous. No artist could picture the scenes more convincingly. But now, having mastered the power of representing form, he set to work to make the objects in his etchings subordinate to the general impression he wished to convey; giving more and more attention to the qualities of light and atmosphere. Having learned to put in, he became learned in leaving out; and in his later series of Venetian etchings confined himself to a few lines contrasted with large spaces of white paper. But the lines are used with such wonderful knowledge and skill that they are sufficient to suggest the character of the objects, while the chief meaning is given to the empty spaces. These cease to be mere paper; they convey the impression of water or sky under the effects of atmosphere and light, and, moreover, they stimulate the imagination.

Remembering Whistler's preference for suggestion rather than actual picturing, one can

understand his fondness for etching, since the latter demands an effort of imagination, first of all upon the artist's part to turn the varied hues of nature into black and white, and then upon the spectator's to turn these back into hues of nature. And while this is so in the case of *color*, it is much more so when it comes to the point of creating an impression of *atmosphere* simply by means of a few lines on a sheet of white paper.

In the "Portrait of the Artist's Mother" black and white again are important, combined as they are with the gray of the wall and the very dark green of the curtain: the grave harmony being solely relieved by the soft warmth of the face. This "quietness" of color-scheme and this accent of tenderness contribute very largely to the emotion aroused in our imagination. Observe how the upright line of the curtain and the diagonal curving line of the lady's figure are painted so that they shall make us feel in one case the folds of the curtain and in the other the figure beneath the dress. But these masses are softened by the hands and the head. The former are laid one above the other with a gesture of exquisite composure, their color rendered more delicate and tender by being shown against the white handkerchief. The gray wall behind the head assists in creating a feeling of atmosphere, enveloping the head in tenderness, while the little accents of dainty suggestiveness that appear in the white cap soften the fixed expression of the face. In this is concentrated the calm and tender dignity to which every other part of the canvas has contributed. I speak of "calm and tender dignity," but who shall put into exact words the qualities of mind and feeling which lie behind that searching gaze? That face speaks to each and every mother's son with a different appeal; it speaks in a universal language that each can understand but no man can fully comprehend. Yet, once again, let us note that the expression of the face is the center and climax of the whole canvas; the result of the exquisite balance of the full and empty spaces and of the tender dignity of the color-scheme of black and gray.

Whistler's fondness for gray, which even caused him to keep his studio dimly lighted, just as the Dutch artist Israëls does, may be

traced to his study of Velasquez, as also his subtle use of black and white, and the preference he shows for sweeping lines and imposing masses. Often in the apparently haphazard arrangement of the masses and spaces there is a suggestion of Japanese influence, as well as in the introduction of a hint of something outside the picture. Note, for example, the apparently accidental spotting of the picture on the wall, and the portion of another frame, peeping in, as it were, from outside. From both Velasquez and the Japanese he learned the value of leaving out rather than of putting

in; the charm of delicate harmonies and the fascination of surprise.

Whistler and Sargent belong to America, but are claimed by foreigners as, at least, citizens of the world. Sargent, with the exception of a few months at distant intervals, has spent his life abroad; Whistler, since about his twentieth year, was a resident of Paris and London, occasionally visiting Holland. The artistic influences which affected both were those of Europe. Yet their Americanism may be detected in many admirable qualities that are characteristic of the best American art.



"DEAR ME, BUT A MOTHER IS BURDENED WITH CARES!"

IF I WERE QUEEN.

BY LUCY FITCH PERKINS.



If I were Queen of Anywhere
I'd have a golden crown,
And sit upon a velvet chair
And wear a satin gown.

A knight of noble pedigree
Should wait beside my seat

To serve me upon bended knee
With things I liked to eat.

I'd have a birthday cake each day
With candles all alight,—
I'd send the doctors all away,
And sit up late at night.



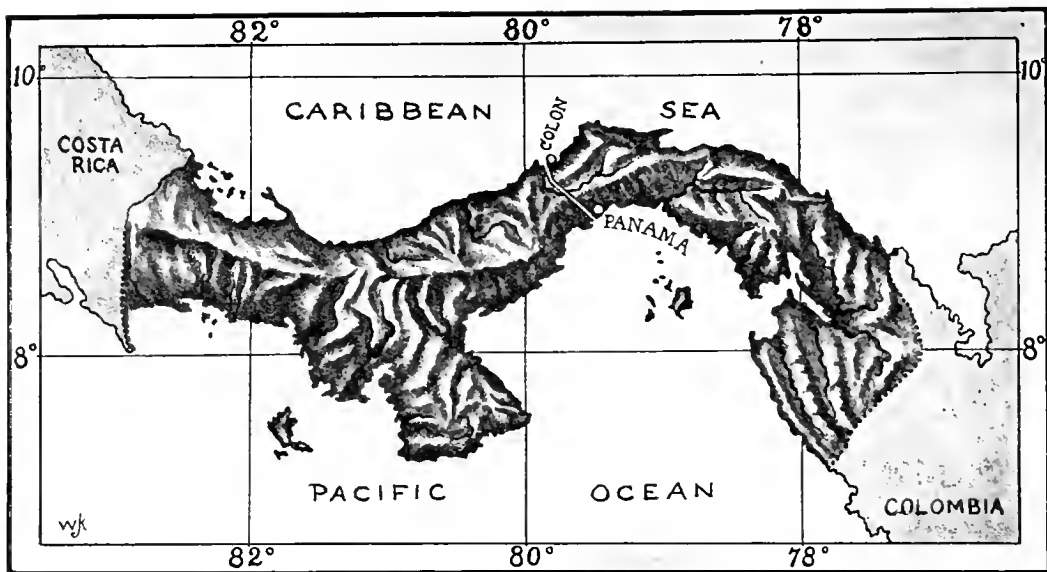

MAP OF THE REPUBLIC OF PANAMA, CONNECTING CENTRAL AND SOUTH AMERICA.

A LITTLE TALK ABOUT THE BIG PANAMA CANAL.

BY WALTER KENYON.

By our recent treaty with the new Republic of Panama she gives us control of a strip of land ten miles wide and extending from sea to sea—or about thirty miles. Through the middle of it lies the partly dug canal. This piece of land is often spoken of as the “canal strip” or the “canal zone.” Our government paid Panama ten million dollars for the strip and the rights that go with it. It will in most respects be just the same as a part of the United States. Our soldiers will police the canal zone, and any special rules and regulations needed will come from Washington. The cities of Colon and Panama do not go with the strip, although they lie within it. They remain a part of the Republic of Panama; but it is understood that we shall have much to say about keeping those cities clean and healthful.

As to the canal itself, our government of the United States has agreed to complete it and keep it open for the use and benefit of all countries forever. The canal is to be, in the truest sense of the word, a highway for all nations.

One would naturally expect, in traversing

the canal from the Atlantic (or Caribbean) side, to be journeying westward; but instead, he is traveling in a southeast direction, and when he arrives at Panama he is some miles *east* of Colon, his starting-point. This is perplexing until we glance at the map. The trend of the isthmus itself is not north and south, as many imagine, but east and west. And the northernmost part of the isthmus is not at the end but at the middle. To the Panaman the great Pacific is a southern, not a western, ocean. And this is why Balboa christened it the South Sea as he waded into its thundering surf four centuries ago.

HOW THE CANAL CAME TO BE.

It might be said that the Turks of the fifteenth century are responsible for the Panama Canal. By capturing Constantinople in 1453 they made good their ownership of Asia Minor and Palestine, already under their control; and before that time the great trade routes between Europe and India had traversed those regions. But now the Turk having laid his rule across

the old caravan lines, Europe began to think about other ways of getting to India.

So it was that Columbus came to the front with his project of going west instead of east. And his great voyage in the caravels was to test such a route. Every school-boy knows that, instead of finding India, he ran upon strange lands which were later called America. Indeed, it was Columbus himself, in his fourth voyage (1502), who discovered the great isthmus which is now to be cut through. But he did not know it was an isthmus, with another ocean beyond it. He died supposing that all these new lands he had found were portions of Asia.

Ever since that day the white man has been quite busy enough in settling the vast lands of America and building new nations there. But at last we are turning back to the original problem of Columbus—how to get to Asia from our Atlantic ports by sailing west.

One project has been to find a "northwest passage," among the Arctic islands and down through Bering Strait. Many a daring ship's crew has suffered and died among the icebergs

southwest passage, and finally found the strait which bears his name. But Magellan's Strait is hardly better than around Cape Horn. Besides being a place of fearful storms, it makes the circuit of the great South American continent necessary, after all.

And so, in our own day, the whole world's attention is focused upon the grand project of "bucking the center," as a football man would say: of cutting the continents apart at Panama. And thus will the dream of Columbus come true. A straightway course will be had from the Atlantic ports to the far lands of spices and silks.

WHAT THE CANAL WILL DO.

FIRST of all the Panama Canal will fulfil the dream of Columbus, by opening a direct route from Europe and Africa to the Orient. But since the day of the great explorer many new lands have been populated. Besides the great ports of China and the Indies, there are all those of western America, from Chile to Alaska; and those of Australasia and the Pacific isles. Then,

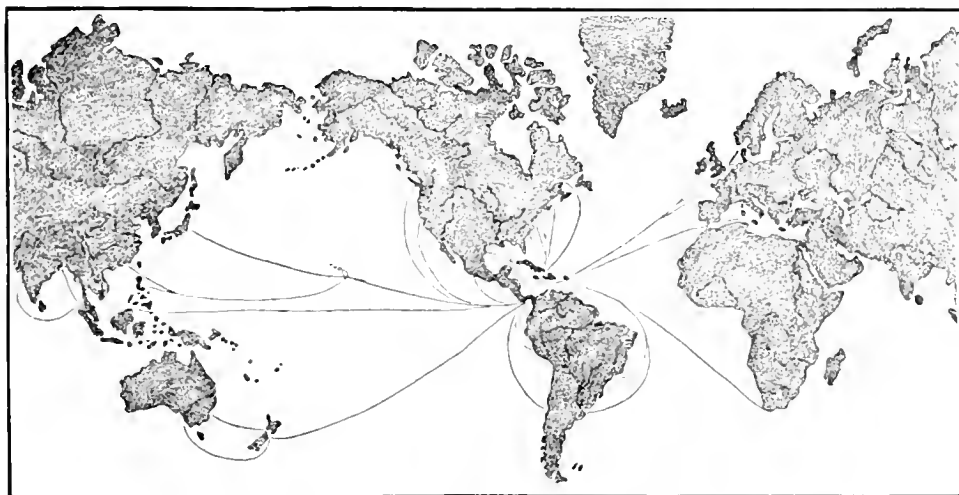

MAP SHOWING HOW THE PANAMA CANAL WILL SHORTEN THE GREAT OCEAN ROUTES OF THE WORLD

of the Arctic Ocean in this search. But the way was long and the seas were filled with ice, and this northwest passage is no longer thought of.

Then there was Magellan, following close upon the heels of Columbus. He tried for a

in addition to our own busy Atlantic seaboard and that of South America, there is the Mississippi Valley. Down through its center rolls the "Father of Waters"—a splendid river-course out of the greatest food country, the greatest iron country, the greatest cotton country, which the

world has from which to draw its supplies. And one thing more: we are the busiest manufacturing country in the world. East and west, north and south, the nations of the earth are buying, not alone our grain, our cotton, and our beef, but also the things we *make*—the tools and machinery, the clothing, and the thousand and one articles to be found in every house. And when the isthmus is cut we shall have a gateway through which to carry this enormous mass of trade products to the peoples of the Pacific.

When the canal is opened it will carry the lion's share of the traffic of all these vast populations. The Panama and the Suez canals will be rivals for the world's ocean commerce; Magellan's Strait and Cape Horn will know the currents of trade no more. They may be forgotten, and the white sails of ships and the black smoke of steamers may almost disappear from those stormy latitudes. The expression "rounding the Horn" may become a saying of other days. The wild Fuegians may scan their blank horizon and tell their children of the great fire-ships that used to pass, and wonder why they come no more.

The Panama passage will shorten the sea

journey from New York to San Francisco by over eight thousand miles. A freight-steamer on this route will save three thousand dollars' worth of coal each trip; and she will be able to make five trips a year instead of two. Peru will be four thousand miles from New York instead of ten; and six thousand miles from Europe instead of twelve.

No story can better illustrate the great need of the Panama Canal than that of the splendid race against time made by our huge battleship the *Oregon*, during the Spanish War. She lay in far-away Puget Sound, and was wanted at once in Cuban waters. In the great need of the moment, how tantalizing became that narrow neck of land, the Isthmus of Panama! Only thirty miles across, yet that thirty miles compelled Captain Clark to take his battleship clear around the South American continent. Fourteen thousand miles instead of four thousand! Fifty-nine days of furious steaming under forced draft instead of less than twenty-one days! That was a wonderful race, "around the Horn," and it was equally wonderful that the big fighting-ship sighted the blue mountains of Cuba just in the nick of time to do her full share—and more—in the great sea-fight.

A NATURE-LESSON.

BY CAROLYN WELLS.

SAID grandpapa to Tommy White:
"That is a maple-tree;
And standing next it, toward the
right,
A slippery elm you see."

"A slippery elm!" cried Tommy;
"oh,
Slippers are nice to wear!
And when quite ripe and red they
grow
I'll come and pick a pair."



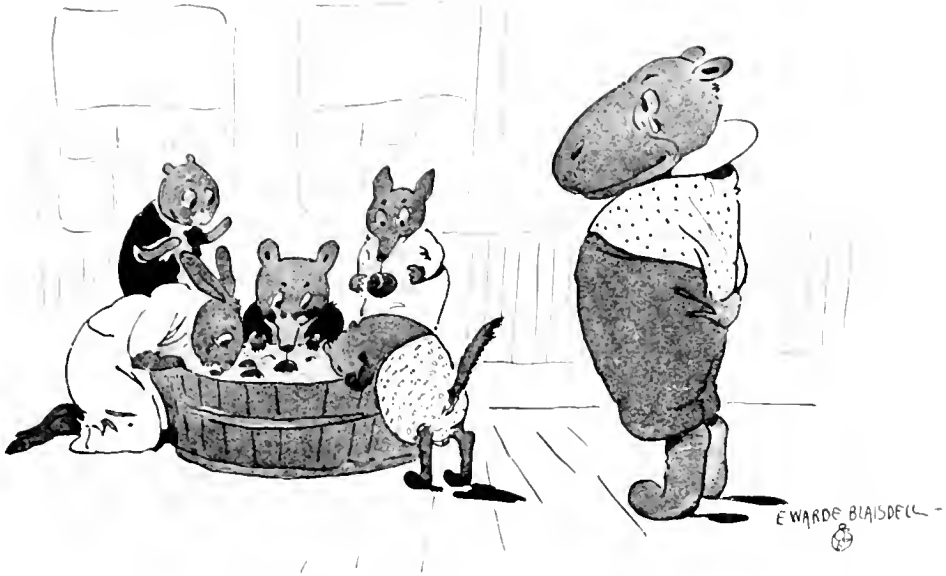

AN UNFAIR ADVANTAGE ON ONE SIDE OR THE OTHER. LITTLE WILLIE HIPPO FELT BADLY BECAUSE THE OTHER FELLOWS WOULD N'T LET HIM BOB FOR APPLES.

FIRST AID TO THE INJURED.

BY DR. E. E. WALKER.

VI. WOUNDS AND HEMORRHAGES.

ONE day the boys and Mr. Wilson were prowling around the island on a "voyage of discovery," as John called it. They had a secret hope that they would find a stray arrow-head, or even an Indian hatchet-head — for at one time this very region was famous for its Indian relics. Their search being in vain, they gathered many small strips of wood, which they brought back to the shade of the giant trees surrounding the camp. Mr. Wilson, as soon as lunch was over, showed them how to use their jack-knives in making these strips into pretty paper-cutters, for the wood was soft, and the knives might easily slip if they used them carelessly. But Jerry, who was always in a hurry to see the end of things, hurried a little too much, and in splitting a piece

of the driftwood his camp ax slipped and cut an ugly gash in the fleshy part of his hand.

"Jee-whill-i-kins, guardie! I've done it now — I've cut my hand."

Jerry was not fond of the sight of blood, and he began to grow very white and faint. Mr. Wilson laid him flat on his back, putting a very small pillow under his head. He then raised the injured hand, and had John hold a handkerchief tightly over the cut while he brought out the bandage-box and gently but firmly bound up the hand. Jerry soon recovered his spirits; for although the hand at first bled freely, it was not a very bad cut, and the boys were soon chatting gaily again.

"Guardie," said Jerry. "I think we're doing

our part to make our 'First Aid to the Injured' a grand success."

Mr. Wilson laughed and said: "I see that you're suggesting that I now do my part. Well, let it be 'Wounds and Hemorrhages' this time.

But just a word about fainting." At this Jerry blushed. "You need n't mind that, Jerry," said guardie, kindly. "Fainting is beyond our control, and there is no reason for being ashamed of it. Whenever a person faints, lay him down. *Never* set him up straight in a chair, as they did when your sister fainted last summer; for that is the very



A TOURNIQUET.

worst thing that can be done. Open his collar and loosen any tight bands; give him plenty of air — do not let a crowd gather round and cut off all the fresh air there is. Then give him a drink of water. Fainting is due to a lack of blood in the brain, and, by laying the person down, of course you offer a chance for the blood to flow back again to the brain. If a person has had a shock, his face will look pale and pinched; he will breathe feebly; his eyes will be partly closed; he will feel cold, and maybe shiver; and sometimes he is even delirious. Occasionally you see such signs after just a little injury. In such a case do about the same thing that you would do when any one faints; only, of course, for the cold you would want to warm him up by giving him a little whisky in hot water—about a tablespoonful every few minutes for three or four times; then—just as we did for your sister last summer when she was poisoned and felt so cold—we would put the person to bed in blankets and put hot-water bottles or hot bricks near him to get him warm. But be careful that all the hot things are well covered up, and that the bottles don't leak; otherwise you may burn or scald

your patient. Now, do any of you know really what happens when you cut yourself?"

"I know one thing," said John: "if you cut an artery, the blood is red and spurts; and if you cut a vein, the blood is bluer and flows."

"That 's right; but in real accidents you generally have both, and so there is a mixture of the blue and red. If the bleeding is very bad, tie a large handkerchief around the injured arm or leg, with a knot over the artery about an inch above the cut. Slip a stick through the place where the handkerchief is tied, and twist it until the knot is pressed deeply against the artery. It would be well to tie a string around the arm over the other end of the stick to prevent its unwinding. In this way you compress and close the walls of the artery between the cut end and the heart, and thus you stop the bleeding. Cold or heat in any form also helps to stop bleeding, for they both help to clot the blood; and of course when the blood clots it acts like a stopper in a bottle, and so the blood ceases to flow out."

"Guardie, what do you do when your nose bleeds?" said John.

"You hold the head up, so as to keep as much blood as possible away from it. Then you put ice or cold water on the back of the neck and over the bridge of the nose. It is a good thing, too, to take in long breaths, one right after another, and you may try snuffing up a very little cold water."

"Mother always puts the big door-key on my neck," said John.

"That has the same effect as the ice," said Mr. Wilson. "But there 's another kind of hurt that often befalls you boys, and I dare say you don't know that it is a hemorrhage."

Mr. Wilson explained that whenever they had a bruise which turned black and blue, the tiny vessels underneath the skin had been injured and the blood had leaked out.

"Well, I know what to do for that," said John. "Whenever I get a bruise, I clap on a cloth wet with hot water or witch-hazel."

"And if you have no witch-hazel, you might use alcohol and water, half and half. Come on now, boys! It's time to get supper."



Totsi and the Cherry-bough

BY MARGARET JOHNSON.

WITHIN the far-off Sunrise Land,
The country where the day begins,—
About whose shores the morning mist
A shining web of wonder spins,
Long, long ago, a little lad
Once lived by Kuni-goyoto,
A little lad of gentle guise,
With yellow skin and almond eyes,
The son of good Yoshigo San;
Nor will you find in all Japan
A bonnier boy, or braver, than
The little Totsi-Toyoto:
In Yokohama, Tokio,
Nagasaki, Hakodate,
Kobe, Kioto.

He seldom laughed, he never cried,
In his mama's kimono curled,
But smiled his bland, mysterious smile,
As babies will, upon the world,
And, as he grew, sedate and sweet
With more than boyish gravity,
He ne'er was known to romp or shout
Or throw his paper toys about;
He never frowned, this little Jap,
But smiled and smiled and took his hap,
The philosophic little chap,
With Oriental suavity.

His parents, poor but honest folk,
Beheld with pride their little boy;
And for his sake they ate their rice,
Content, with but a dash of soy.

They let him wear a lovely gown,
As you might well be glad to do;
They gave him baths, all boiling hot
(He much preferred them so than not),
And cooked him seaweed, snails, and fish,
With many another dainty dish,
Which you, perhaps, against your wish,
Might taste, and find it sad to do!

They taught him how to make his bow,
To use his fan in ways polite;
And, best of all, they gave to him
A little mirror, round and bright,
For you must know,
on Nippon's isle,
In days of great
antiquity,
Each little Shinto
boy was taught
The glass would
show his every
thought,
And ere he slept (if
sleep he could,
Upon a pillow made
of wood!)
Each night he looked in trembling doubt,
And smiled, his foolish fears to flout,
If clear the mirror shone, without
A shadow of iniquity.

So Totsi lived,— a model child,—
Until one fatal April day,





"AND THERE TEMPTATION DID
BEFALL!"

And there temptation did befall!

He paused — he gazed — he climbed the
wall,—

To steal the cherries? Not at all,

'T was not the fruit he cared about!

But oh, the blossoms pink and white,

A cloud, a wealth of bloom untold!

What little Jap without a thrill

That dazzling vision could behold —

In Yokohama, Tokio,

Nagasaki, Hakodate,

Kobe, Kioto.

Not he; for in those ancient days

The gentle Japanese, you know,

Had plants for pets,— a peach, a plum,

A lily or chrysanthemum,

And Totsu — not a pet had he!

He looked — he longed — he climbed the
tree,

One bloomy bough he broke — ah me,

'T was such a little piece, you know!

Yet as he fled, he dared not look

At Fusi-yama, stern and high

When home from
school along the
road

He smiling took
his peaceful
way.

In proud O Haru's
garden grand

What was there
to be scared
about? —

Alas! her favorite
cherry-tree

Beside the wall he
chanced to see;

(Though next, I think, to his mama

He loved the mountain in the sky!),
And fearing in his glass to peep,

That night, when he was sent to bed,

What Japanese hobgoblins came
To scare his dreams with eyes of flame,

What horrid imps and dragons fell,
I will not try, indeed, to tell.

But ere the rosy morning broke,
Resolved, the hapless boy awoke:

Confession should those goblins choke

Ere back he stole, content, to bed!

Now, in her pretty paper house,

Not far away, O Haru San

Beside her paper window sat,

Just like a lady on a fan.

Red rose the moon behind a screen

Of purple-bright wistaria:

Within, a scroll upon the wall,

A vase or two, and that was all,

Except the honorable mat

Whereon the lovely lady sat.

A sweet kimono, primrose-hued,

She wore, with storks and lilies strewed,

And thus all night the moon she viewed,

Regardless of malaria.

To her, absorbed in tea and thought,

Did Totsu come to pay his call.

(He left his shoes, and not his hat

Within the honorable hall.)

He bowed and bowed and bowed and bowed,

He smiled and smiled and smiled again;

His heart — he did not stop for that —

Went Japanese for pit-a-pat.

He told his tale with touching grace;

Alas, how cold her lovely face!

Could she, but for a moment's space,

Have felt herself a child again!



"LET AS HE LIED, HE DARED NOT LOOK AT
FUSUYAMA, STEAKS AND BIRCH."

"Who steals," she said, "he must restore.
You are forgiven,"—how stern her
brow!—
"When fresh as first its blossoms burst,
You bring me back my cherry-bough!"
Low Totsi knelt (he smiled, of course,
And sought the outer room again;
Where, tumbling blindly through the
wall
(T was only paper, after all! :

As in a dream he homeward sped,
The dawn above him deepening
red:
All wilted was the bough, and
dead,—
How *could* he make it bloom again!"

He thought all day, he dreamed all night,
The smile grew wan about his lips,
He listless watched his good papa,
Who worked with busy finger-tips,
For lovely lacquer bowls he made,
And jars of priceless pottery,
And painted—Totsi's eyes grew wide—
He, too, the gentle craft had tried,
To-day— at once—he would begin!
(And, oh, what fun it must have been
That pretty chry to dabble in,
All soft and terra-cotta-ry!)

The storks went flying day by day
About the groves of tall bamboo,
(I wonder if they really looked
As on the teapots now they do!)
Afar the great Mikado reigned
In solitude imperial,
O'er Yokohama, Tokio,
Nagasaki, Hakodate,
Kobe, Kioto,

The careless world swung high, swung low,
And still by Kimmi-goyoto
A little lad, all pale with thought,
With cunning skill and patience wrought,
By Nature's self divinely taught,
A work of art ethereal,

Then dawned at last a joyous day,
When proud O Haru dressed her hair,
And gave a garden-party, gay
With sports polite and debonair,
The prettiest girls in all Japan
They flocked from near and far to her,
And shone, beneath the smiling skies,
Like many-tinted butterflies,
Then, treading softly, as before,
Came Totsi to the garden door,
His treasure bore he on his knee:
"Will Her Augustness deign to see
The worthless gift I bring?" said he,
And, trembling, gave the jar to her,



" BESIDE HER PAPER WINDOW SAT, JUST LIKE A LADY ON A FAN "

Oh, miracle of loving skill!

Oh, marvel of the potter's art!

O Haru dropped her
samiesen

And gazed with won-
dering lips apart.

For, fresh as first its
blossoms burst,

She saw her stolen
cherry-bough:

Each airy twig, each
petal pure,

Portrayed with touch
so fine and sure

That none may paint its
like, mayhap.—

Except another little
Jap!



" Now yours," she cried, " and fairly earned,
The grace that once to give I spurned!

For what you took you have returned—

It is the same, the very hough!"



With laughter low and soft amaze
They flew the gift to celebrate;
They drank the honorable wine,
The honorable cake they ate;

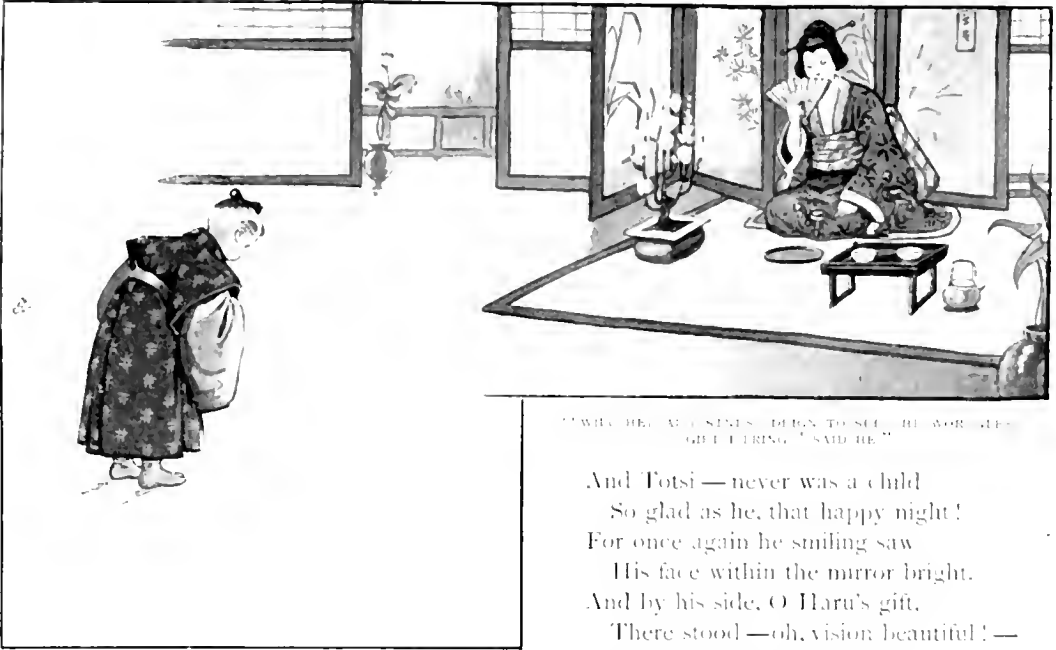

"WILL YOU, MY SENSES, DEIGN TO SEE, MY WORSHIPFUL
GIFT BRING," SAID HE.

And Totsu — never was a child
So glad as he, that happy night!
For once again he smiling saw
His face within the mirror bright,
And by his side, O Haru's gift,
There stood — oh, vision beautiful! —
Instead of cake or sugar-plum,
A darling white chrysanthemum!
So ends the tale.

And what they could not finish (though
It may not seem polite to you!)
In sleeve and sash they tucked away
To carry home and eat next day!
So, swift the festive hours they sped,
And when the moon was rising red,
Their "Sayonaras" sweet they said
"The Japanese " Good night to
you!"

Ah, long ago
He lived by Kinni-goyoto;
Yet in the land of far Japan
Still may you read, on vase or fan,
The tale of proud O Haru San
And Totsu, dear and dutiful:
In Yokohama, Tokio,
Nagasaki, Hakodate,
Kobe, Kioto.





THE
BUTTONS
AND
BUTTON-HOLES
BY
LITH KIMBALL GARDNER



In the first street to the east of the Capitol in Washington, there stands a row of three tall houses. They have been remodeled many times, but the bricks of their walls remain as they were set nearly a hundred years ago. After the British marched in, along Maryland Avenue, to burn the Capitol those walls sheltered Congress. Nearly half a century later, in war-time again, the place was a prison where political and military prisoners were confined. It was only after the war that the old walls came at last to be the boundaries of homes, and to-day there is nothing about the tall houses to suggest that they were once the famous Capitol Prison.

It was in the war-time of President Lincoln that Louisa Carr first saw Washington and the prison.

Louisa's father was in the army, and one day his name was in the list of wounded. A little later, she and her mother heard that he had been taken to a hospital in Washington, and they went there to be near him. For several months they were together again, and then Captain Carr went away to the front once more, and Mrs. Carr and Louisa stayed in Washington.

They lived at the house of a Mrs. Thompson, not far from the Capitol, and Louisa passed the prison every day on her way to school. Mrs. Thompson's son, who was a soldier, was a guard at the prison, and Louisa often saw him on duty at the gate. He never failed to present arms as she passed. In return, she brought her hand up in the salute every soldier's daughter

knew in those days. Sometimes she would send food or a few flowers to the prisoners who

Corporal Thompson said were homesick, and once or twice she went with her mother to visit them.

Mrs. Thompson was a widow, and in addition to giving board and lodging to Louisa and her mother, she took in sewing. She was a tailor as well as a dressmaker, and when she was unusually busy, Louisa liked to help her. Sometimes, when a gown or cloak was to be fitted, the little girl tacked hooks and eyes on, for Mrs. Thompson fitted with great care, and hooks and eyes must be sewed on exactly where the buttons and button-holes were afterward to be. One day, when Mrs. Thompson was rushed with work, Louisa sewed hooks and eyes on a lady's silk cloak. She put the hooks on the left side of the front, and the eyes on the right.

"Oh, Louisa!" said Mrs. Thompson, when the little girl showed what she had done, "they will all have to be taken off, and sewed on over again. A lady's cloak always fastens with the right side over the left. You have the hooks on the wrong side."

Louisa changed the hooks and eyes, but she heard the lady who had come to be fitted complain of the delay, and Mrs. Thompson looked worried and distressed.

"I'll know better next time," Louisa said. "I'll remember that coats always button toward the left side."

"Only coats for women and girls," said Mrs.

Thompson. "Men's coats button in exactly the opposite way."

Louisa took care to notice the coats she saw in the street. She found that, as Mrs. Thompson had said, every man's coat had the button-holes in the left side of the front, and every woman's, in the right side. The cloaks of even little children followed the same rule. She noticed that most boys buttoned their jackets with their right hands, and most girls buttoned theirs with their left hands. When she saw the President and his wife driving, one day, she was so intent on their buttons and button-holes, that she quite forgot to look at their faces. Mr. Lincoln buttoned his coat with his right hand.

She looked at all the pictures her mother had, and saw that the custom must be a very old one. In the miniature of her great-grandfather, painted in ruffles and powdered hair, the queer long coat had a row of button-holes down the left side, and in the picture of her great-grandmother, in hunting-dress, the button-holes were on the right side. She wondered why this was, but, although she inquired of many, she found no one who knew the reason for it.

"I suppose there must have been some reason for it in the first place," her mother said. "The two buttons on the back of a man's coat, you know, were originally used to button the skirts of his coat back out of the way of his sword. Perhaps men and women walking together were thought to look better if their cloaks buttoned in opposite ways."

Louisa did not consider this a good explanation, for she thought that since men had to use their right hands to draw their swords there was as much reason for their coats buttoning to the left, as for women's cloaks fastening in that way. Another explanation seemed to her much more satisfactory.

"Is n't it easier for you to button my cloak, when you stand in front of me, if the button-holes are in the right-hand side?" she asked.

"It seems so to me," said Mrs. Carr.

"Well, then," said Louisa, "I think the reason for it must be that all ladies are expected to have somebody to wait on them, and button their cloaks for them."

Mrs. Thompson and Mrs. Carr smiled at her

earnestness, and agreed that her explanation might be the right one.

"And, my dear, just button your own cloak now," said Mrs. Carr, "and take this message for me to my old friend Mrs. Mitchell. Tell her I find I can't possibly come to-day, but that I will certainly call on her to-morrow."

It was about the middle of the afternoon when Louisa set out, and her way took her past the prison. Corporal Thompson was on guard at the gate, and she stopped to speak to him. A carriage was just driving away, and she wanted to know whether it had brought another prisoner or taken one away.

"It brought a visitor," the corporal said.



"SHE BROUGHT HER HUSBAND TO VISIT."

"The wife of an officer who was captured last week. He was acting as a spy."

"Will he be shot?" asked Louisa, for she knew the usual fate of spies.

"I don't think so. He was within our lines, but he was partially in uniform when he was captured. The President is too kind-hearted to have any one shot if he can find an excuse for saving him."

"But won't the spy tell his wife things that could do harm?" asked Louisa.

"The guard at the door of his cell can hear every word they say," the corporal explained.

Louisa went on about her errand, and enjoyed her visit with Mrs. Mitchell so much that it was

the bars of the gate she could see the visitor crossing the yard. She was a tall woman, in a long, loose open cloak. She passed the guards very leisurely, and almost stopped once to fasten the veil over her bonnet. She nodded to Corporal Thompson as she passed through the gate, and beckoned to the coachman who was waiting with her carriage across the street. He turned the horses and drove up to the curb. The visitor spoke to him, and then as a gust of wind blew her cloak open, she did something which made Louisa jump with astonishment. She lifted her right hand and fumbled with it in buttoning her cloak. This instantly attracted Louisa's attention, and she started toward the corporal with a sudden gesture of surprise. The next moment the wide hoop-skirt tilted a little as the carriage-door closed and Louisa caught a clear glimpse of a man's boot.

She sprang forward and seized the corporal by the arm.

"Stop it!" she gasped, pointing to the carriage rolling away down the street. "You must stop it! It was n't a woman!" Louisa screamed. "It was a man. He tried to button his cloak with his right hand; and — and — I saw his boots!"

Corporal Thompson dashed after the carriage, firing his gun to give the alarm. The street was in an uproar in an instant. Guards seemed to spring up everywhere. Louisa saw the carriage stopped, and a person, who, stripped of the disguise of bonnet



"SHE STARTED TOWARD THE CORPORAL WITH A SUDDEN GESTURE OF SURPRISE."

dusk when she started home. Corporal Thompson was still on guard when she passed the prison.

"Will you please wait a moment?" he asked. "As soon as I pass this visitor out, I want to send a message to my mother."

Louisa stepped back and waited. Through

and veil, was unmistakably a man, taken from it, and back into the prison.

Then she ran home. The secrets the spy knew could do no harm now to the cause for which her father was fighting. Buttons and button-holes had saved the day.

THE PRACTICAL BOY.

BY JOSEPH H. ADAMS.

TWELFTH PAPER.

ELECTRICAL APPARATUS.

CELLS AND BATTERIES.

IN order to generate electricity it will be necessary to have batteries or dynamos; but as the construction and operation of a dynamo is somewhat beyond the possibility of the average boy, the battery will necessarily have to be depended upon for the electric current. There are various kinds of batteries that might be used. For electric bells, small magnets, and motors the zinc-carbon sal-ammoniac battery will answer very well; but for larger apparatus where more power is required the bluestone and the bichromate batteries will be necessary. A simple and inexpensive cell can be made from electric-light carbons with the copper coating removed and pencils of zinc, such as are used for electric-bell batteries, and which can be purchased for five cents each. Copper wires are to be bound around the top of each and twisted with pliers, so that they will not become detached. It will be well to cut a groove with a file around the top of both the carbon and zinc into which the wire will fit; then the elements should be clamped in between two pieces of wood and held with screws, as shown in Fig. 1. Another arrangement is shown in Fig. 2, where a zinc rod is suspended between two carbons, the carbons being connected by a wire that must not touch the zinc. A fruit-jar or a wide-necked pickle-bottle can be employed for a cell; but before the solution is poured in, the upper edge of the glass should be coated with paraffin. The solution is made by dissolving four ounces of sal-ammoniac in a pint of water, and the jar should be filled three fourths full. In this solution the carbons and zinc may be suspended, as shown in Fig. 5 on the next page. Plates of zinc and carbon may be clamped either side of a square stick and suspended in the sal-

ammoniac solution, as shown in Fig. 3, taking care, however, that the screws used for clamping do not touch each other.

If one cell is not sufficiently powerful, several of them can be made and coupled up in series

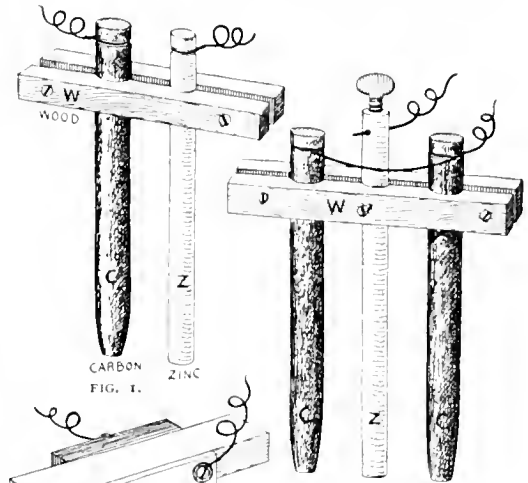

CARBON
FIG. 1.

FIG. 2.

DIFFERENT FORMS OF ELECTRODES.

FIG. 3.

—that is, by carrying the wire from the zinc to the carbon of the next cell, and so on to the end, so that the wire from the carbon in the first cell and that from the zinc of the last cell will be the ones in hand, as shown in Fig. 4.

This battery is an excellent one for bells and small experimental work, and when inactive the zincs are not being eaten away, for corrosion takes place only as the electricity is required.

A series of batteries of this description will last about twelve months, if used only for a bell, and at the end of that time will require only a new zinc and solution, or maybe only water.

A cell using plates shown in Fig. 3 can contain a bichromate solution, and for experimental work, where electricity is required for a short time only, this will produce a stronger current; but, as the solution eats the zinc rapidly, the plates must be raised out of the liquid as soon as you have finished with them.

The solution is made by slowly pouring four ounces of commercially pure sulphuric acid in a quart of cold water. This should be done in an

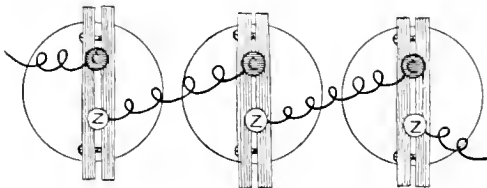

FIG. 4. CELLS CONNECTED "IN SERIES."

earthen jar, as the heat generated by adding acid to water is enough to crack a glass bottle. Never pour the water into the acid. When the solution is about cold, add four ounces of bichromate of potash, and shake or mix it occasionally until dissolved; then place it in a bottle and label it "Bichromate Fluid for Battery." Before the zincs are immersed in the bichromate solution they should be well amalgamated, to prevent the acid from eating them too rapidly. The amalgamating is done by immersing the zincs in a diluted solution of sulphuric acid for a few seconds, then rubbing mercury on the surfaces. The mercury will adhere to the chemically cleaned surfaces of any metal but iron and steel, and prevent the action of acid eating or corroding them away as quickly as it would the bare metal. Do not get too much mercury on, but enough only to give the zinc a thin coat.

A two-fluid cell is made with an outer glass or porcelain jar and an inner porous cup, through which the current can pass when the cup is wet. This is shown in Fig. 6.

A porous cup is an unglazed earthen receptacle, similar to a flower-pot, through which moisture will pass slowly. The porous cup contains an amalgamated plate of zinc immersed in a solution of diluted sulphuric acid, one ounce to one pint of water. The outer cell contains a saturated solution of sulphate of copper, in which a cylindrical piece of thin sheet-copper is held by a thin copper strap bent over the edge

of the outer cell. A few lumps or crystals of the copper sulphate should now and then be dropped in the bottom of the jar to keep the copper solution saturated at all times. When not in use the zinc should be removed from the inner cell and washed off, and when the battery is not to be used for a number of days it would be best to pour the solutions back into bottles and wash the parts of the battery, so that it will be fresh and strong when next required for experimental work.

When in action the solutions in both cups should be at the same level. Be careful never to allow the solutions to get mixed or the copper solution to touch the zinc. Coat the top of the porous cell with paraffin to prevent crystallization and also to keep it clean.

For telegraph-sounders, large electric bells, and as accumulators to charge batteries, the gravity cell is employed extensively where there is room to accommodate a number of them. The one shown in Fig. 7 consists of a deep glass jar, three strips of thin copper riveted together, and a zinc spider that is caught on the upper edge of the glass jar. These parts will have to be purchased at a supply-house, as well as a pound or two of sulphate of copper (blue stone). To set up the cell, place the copper at the bottom and drop in enough of the crystals to generously cover the bottom, but do not try to embed the metallic copper in the crystals; then fill the jar half full of water. In another jar

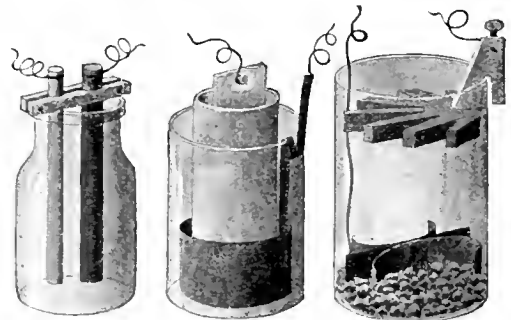

FIG. 5.

FIG. 6.

FIG. 7.

DIFFERENT FORMS OF CELLS.

dissolve two ounces of sulphate of zinc in enough water to complete the filling of the jar to within an inch of the top; then hang the zinc spider on the edge of the jar so that it is immersed in the liquid and about three inches above the top

of the copper strip. The wire that leads up from the copper should be well insulated with a water-proof coating. This and the wire from the zinc are to be connected with a telegraph-sounder and key or to the electric bell or other objects for which it will furnish current.

At first the solutions will mingle, but to separate them join the two wires and start the action, and in a few hours a dividing line will be seen between the white, or clear, and blue solutions, when the cell will be stronger. After continual use it may be necessary to draw off some of the clear zinc sulphate, or top solution, and replace it with clear water, for the action of the acids reduces the metallic zinc to zinc sulphate and deposits metallic copper on the thin copper strips, and in doing so electricity is generated.

BINDING-POSTS AND CONNECTORS.

FIVE very simple posts are shown in Fig. 8. A is made from a screw and two burs; B from a screw-eye and two burs; and C from a thin plate of metal and two screws with oval or round heads. This is more of a connection than a binding-post. The ends of the wires to be connected may be caught under the screw-heads or between the burs before the screws are driven down. In D a simple arrangement of a stove-bolt and two nuts is shown; the under nut is screwed down tightly against the wood,

and under the head a wire is made fast so that another wire may be caught under the upper nut. If a small thumb-nut can be had in place of the plain nut, it will be easier to bind the upper wire. A thin strip of metal can be folded over, and at the loose ends a hole may be punched through which a screw-eye will pass. The metal is held to a wood base with a screw, under the head of which a wire is caught, as shown at E. The second wire-end is slipped between the metal plates, and a turn of the screw-eye will bind it and hold it securely.

Connectors are employed to unite the ends

of wires temporarily, and are made in many forms. Three of these are shown in Fig. 9.

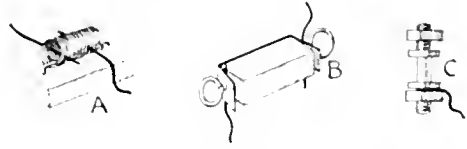

FIG. 9. BINDING-POSTS AND CONNECTORS.

An ingenious form of connector, sometimes used in laboratories, is made of a deep pill-box or wooden salve-box filled with paraffin. One or more holes, separated as far as possible, are made in the wax and are then filled with mercury. For ordinary use one hole or "cup" will answer. The end of a wire coming, we will say, from the battery, remains immersed in the mercury. Then to make the circuit it is necessary merely to dip in the same cup the end of the wire that proceeds to the bell or other piece of apparatus.

SWITCHES AND CUT-OUTS.

A SIMPLE switch (Fig. 10) is made from a piece of wood for a base 3 inches long, 2 wide, and $\frac{3}{8}$ inch in thickness, and some small metal parts. It has but one contact point, that is the brass-headed tack T, driven through the binding-post, which is a small plate of brass, copper, or even tin screwed to the base-block. The end of a wire is caught under the screw-head before it is driven down. A similar binding-post is

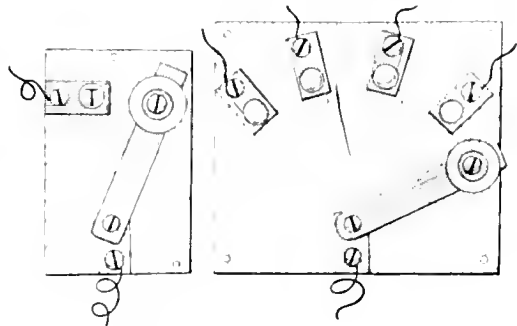

FIG. 10.

FIG. 11.

SWITCHES AND CUT-OUTS.

arranged at one end of the block, and the movable arm is attached to it with a screw. Between the arm and the post-plate there should be a small copper bur to make it work more easily. The arm is cut from a thin piece of hard

sheet-brass or copper (tin or zinc will do very well), and at the loose end the half of a small spool is attached with a brass screw and bur, to act as a handle. The end of the screw that passes through a hole in the arm is riveted to the under side to hold it securely in place.

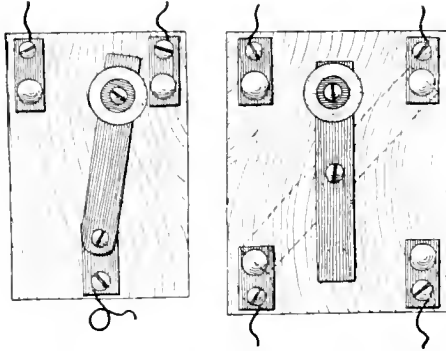

FIG. 12. FIG. 13.
SWITCHES AND CUT-OUTS.

Fig. 11 shows a switch designed to carry the current to one or the other of four lines, and in Fig. 12 a switch to conduct to one of two lines. In Fig. 13 is shown a simple cut-out by which one line may be cut out and another connected, and vice versa, by the same switch.

PUSH-BUTTONS.

The simplest form of push-button is a piece of bent tin or brass screwed fast to a small block of wood, as shown in Figs. 14 and 15; under the screw-head one end of a wire is caught, and the other wire-end is caught under a washer, and a screw driven into the block directly under the projecting end of the strip.

Fig. 16 shows a circular push-button. On top of a box-cover is glued one end of a spool, and through this projects the loose "pusher."

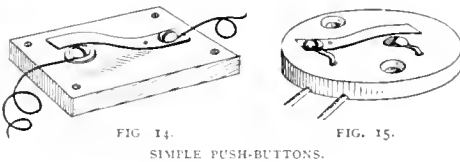

FIG. 14. FIG. 15.
SIMPLE PUSH-BUTTONS.

To prevent the push-button from falling out, a small steel wire nail can be driven through the plug near the upper end; so as to clear the under side of the lid, as shown in Fig. 17. The button

is mounted by first screwing the base, for which one may use the push-button shown in Fig. 15 (after mounting a spool-end on the contact

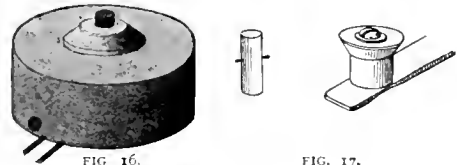

FIG. 16. FIG. 17.
DETAILS OF CIRCULAR PUSH-BUTTON.

strip, Fig. 17), fast to the door, or window-casing after the wires are in place; the button is then set in the hole, and the cover placed over the base, and by means of small screws passed through the rim of the box and into the edge of the base the cap is held in place.

ELECTRO-MAGNETS.

The familiar horseshoe magnet is made of highly tempered steel and magnetized so that one end is a north pole, the other a south, or perhaps more commonly known as a negative and a positive. Once magnetized, it is always magnetic unless the power is drawn from it by exposure to intense heat. An electro-magnet, however, can be made from any scrap of soft iron, from a piece of ordinary telegraph-wire to a gigantic iron shaft.

When a current of electricity passes through

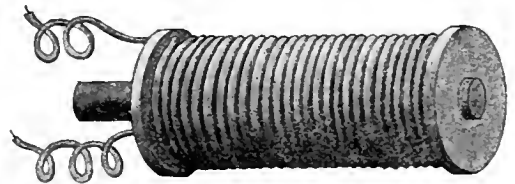

FIG. 18. A SIMPLE ELECTRO-MAGNET.

an insulated wire coiled about a soft-iron object such as a nail, a bolt, or a rod, that object becomes a magnet as long as a current of electricity is passing through the coils of wire or helix. A coil of wire in the form of a spiral spring has a stronger field than a straight wire carrying the same current, for each turn or convolution adds its magnetic field to that of the other turns; and by having the center of the coil of iron, which is a magnetic body, the strength of the magnetism is greatly increased.

A very simple form of electro-magnet is made

by winding several layers of No. 20 insulated copper wire around a stout nail or a carriage-bolt; and, by connecting the ends to a battery of sufficient power, some very heavy objects can be lifted. A single-magnet, like the one shown in Fig. 18, and C in Fig. 19, is made with a piece of soft-iron rod 6 inches long and half an inch in diameter, the ends of a large spool sawed off and worked on the rod, and half a pound of No. 20 insulated copper wire. To protect the outer insulated coil of wire from chafing and a possible short circuit, it would be best to wrap several thicknesses of stout paper around the coil after winding and glue it fast, or a leather cover will answer as well.

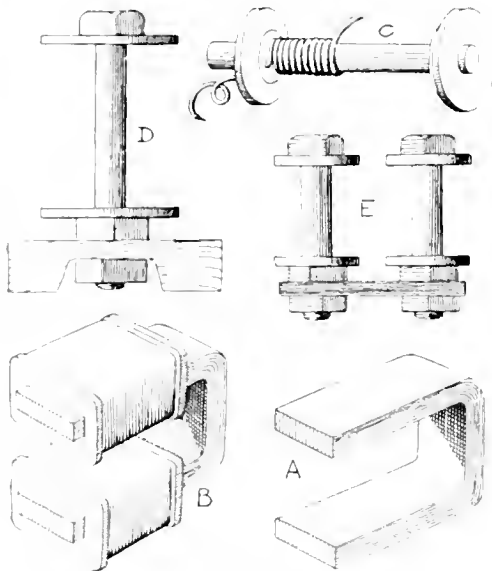

FIG. 19. VARIOUS STYLES OF ELECTRO-MAGNETS

For electric bells, telegraph-sounders, and other electrical equipment requiring the horse-shoe or double magnet several kinds can be used, but the simplest is made from two carriage- or machine-bolts and a yoke of soft iron, as shown at E in Fig. 19. The yoke is $\frac{5}{8}$ of an inch in width, $2\frac{1}{2}$ inches long, and provided with two $\frac{3}{8}$ -inch holes $1\frac{1}{2}$ inches apart from center to center. Two-inch carriage- or machine-bolts are used, and they should be $\frac{3}{8}$ of an inch in diameter; nuts are screwed on far enough to admit the yoke and another nut to hold it in place, and bind the three pieces in one compact mass. Washers are placed on the bolts to hold

the ends of the wire coils in place, and the winding may be done on each bolt separately and connected to the yoke after the winding is completed. Double cotton insulated No. 20 or 22 copper wire should be used for the coils. Be careful to wind the wire in opposite directions on the two cores; or if wound the same way, connect them up so that the current will pass through them in opposite directions.

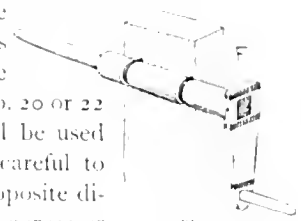

FIG. 20. WINDING DEVICE.

In winding magnets it will often be found convenient to slip the spool over a spindle connected with a crank. Such an apparatus, which is to be held in a vise, is shown in Fig. 20. The thick part of the shank is held loosely against the block by a pair of ordinary staples.

THE INDUCTION-COIL.

A SIMPLE induction-coil is made by winding two coils of wire on a spool through which, as a core, there is a $\frac{1}{16}$ -inch iron bolt, the whole apparatus being about six inches long. First wind three layers of No. 24 cotton-insulated wire, leaving about six inches of the wire projecting from the spool at each end. Over the last layer of this coarse wire wrap several thicknesses of brown paper, and then wind with eleven or thirteen layers of No. 30 insulated copper wire, keeping the layers smooth. Leave also ends of this wire six inches long. Screw a nut on the coil and mount the whole on a block of wood; see Fig. 21. The two

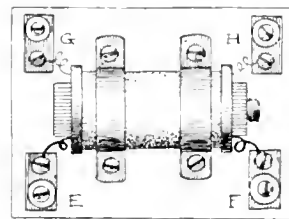

FIG. 21. AN INDUCTION COIL.

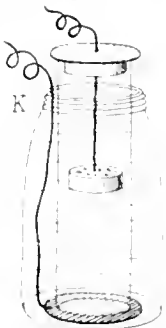

FIG. 22. A BOHLE RESISTOR.

ends of the coarse wire will be connected to binding-posts, as shown in E and F, and the ends of the fine wire as shown at G and H.

In order to get a shock from this coil, it will be necessary to have a pair of handles and a current-interrupter. The handles can be made from two pieces of tin rolled into the form of cylinders, to which wires may be soldered.

If the shock is too intense, it can be weakened by drawing the elements—that is, the carbon and zinc—partly out of the bichromate solution, or a regulator can be made of a Welsbach burner chimney and a glass preserving-jar filled with water. Solder a wire to the edge of a small tin disk, as shown in Fig. 22, on which the chimney rests

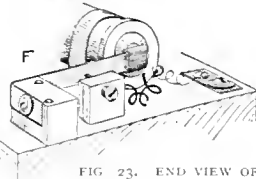

FIG. 23. END VIEW OF INTERRUPTER.

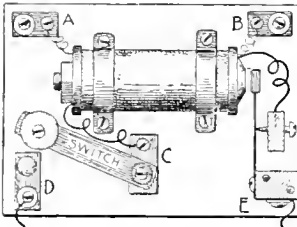

FIG. 24. AN INTERRUPTER.

at the bottom of the jar, and another wire to a tin box-cover, with some small holes punched in the top, and which is suspended within

the chimney. This wire is passed out through a cork at the top of the chimney, made of a disk of cardboard and a piece of wood. One wire is connected with D of the interrupter (Fig. 24), and the other with a battery-pole. This bottle apparatus acts the same as a resistance-coil, and by raising or lowering the box-cover the current is increased or diminished. The action of the interrupter, as far as the vibrating tongue is concerned, will be clear from the description of the buzzer in the next column. Connect the battery with D and E and the handles with A and B.

An effective means of reducing or increasing the "tingling" effect felt by one holding the handles connected with the secondary circuit of an interrupter, is to have a movable iron core to the induction coil instead of the solid iron bolt. When the core is pushed in to fill up the hollow core-space the effect will be strongest. To reduce this, slowly pull out the core. The reason for this is clear. The magnet is stronger when the coils have the solid core. When the iron core is partly withdrawn the coils that have only a hollow air core-space will be weak.

ELECTRIC BELLS AND BUZZERS.

THE general principle of the telegraph-sounder described on page 1119 is employed in the operations of bells and buzzers, but instead of the finger being used to release the armature the current is made to do it, so that a continuous vibration of the armature takes place so long as there is sufficient current running through the coils.

To make a buzzer, cut a base-block $3\frac{1}{2}$ by 5 inches and $\frac{3}{4}$ of an inch thick, and mount a horseshoe-magnet made of bolts and a yoke and coils, about at the middle of it, as shown in Figs. 25 and 27. The magnet is held to the base by a flat wooden cleat and a screw passed down through a hole in the cleat and into the base, between the coils. An armature of soft iron 2 inches long and half an inch wide is riveted to a piece of spring brass, as shown at D in Figs. 25 and 26, and the end bent so that it will fit around the corner of a block to which it is held fast with two screws. This armature is mounted so that there is a space one sixteenth of an inch wide between it and the bolt-heads, as you can see in Fig. 25.

The brass is bent out slightly and runs parallel with the armature for one inch and a quarter and against which the end of the screw mounted in block B, Figs. 25 and 26, rests. The block B is a small piece of hard wood screwed fast to the side of the base to hold the set screw and also the wire that comes from the outside of the upper coil; a small hole is made in the edge of

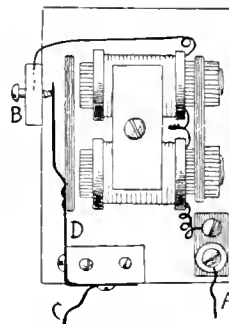

FIG. 25. DIAGRAM OF BUZZER CONNECTIONS.

the block and the wire is passed in so that the end rests in the screw-hole, as shown by the

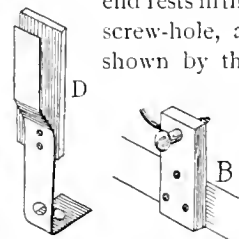

FIG. 26. DETAILS OF BUZZER PARTS.

dotted line. When the screw is placed in the hole and turned it comes in contact with the wire and makes a connection. On the base, near the armature-block a binding-post is made

fast. The current passes in through the wire A, goes through the coils and around to the screw B, then through the armature to the block and out through the wire C. In its circuit the bolts are magnetized and they draw the armature, but the instant they do so the loose spring-brass end is pulled away from the screw at B and the circuit is broken,—the bolts cease to be magnetized then and the armature flies back as the spring-brass neck at D makes it do so. The loose brass-end then, on touching the screw-point, conducts the current through the coils again with the continual vibrating action as long as the electric current is passing in at A and out at C. The greater the volume of current the greater the number of vibrations, and to properly regulate the contact, the set-screw B must be adjusted at the right point.

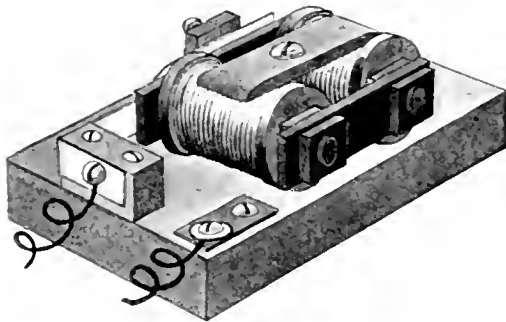

FIG. 27. GENERAL VIEW OF BUZZER.

Paste pieces of heavy paper over the heads of the bolts to overcome residual magnetism.

An electric bell is made the same as a buzzer, but, continuing on from the end of the armature, a wire or rod is mounted with a ball or clapper at the end, which strikes the bell as the current causes the armature to vibrate.

TELEGRAPH-KEY AND SOUNDER.

TELEGRAPH instruments are very simple to make and two boys can easily have a line between their homes.

The key is simply a contact maker and breaker, so that the circuit can be conveniently and rapidly opened and closed by the operator. A simple telegraph-key is shown in Fig. 28. The base-board is 4 by 6 inches and $\frac{1}{2}$ inch thick. At the front end a small metal connector-plate is screwed fast, and, through a

hole in the middle of it, an upholsterer's brass-headed tack is driven for the under side of the

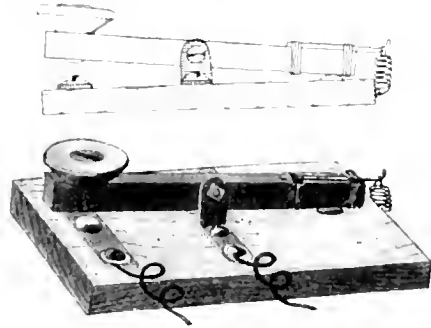

FIG. 28. A TELEGRAPH-KEY.

key to strike against. Two L pieces of metal are attached to the middle of the board to support the key-bar by a bolt passing through them and the bar, and at the rear of the board another upholsterer's tack is driven in the wood for the end of the bar to strike and make a click. The bar is of brass or iron three eighths by half an inch. A hole made at the forward end will admit a brass screw, that in turn will hold a spool-end to act as a finger-piece. The screw can be cut off and riveted at the under side. A short, strong spring is to be attached to the back of the base-block and to the end of the key-bar by means of a hook, which is made from a steel-wire nail, flattened and bound to the top of the bar with wire, as shown in Fig. 28, in the lower figure of which the wires to the bell are shown.

A simple switch can be connected with the L

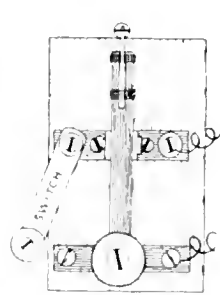

FIG. 29. TELEGRAPH-KEY WITH SWITCH.

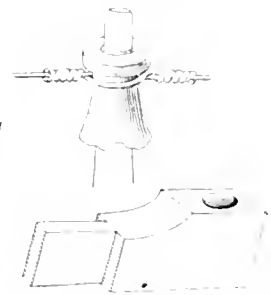
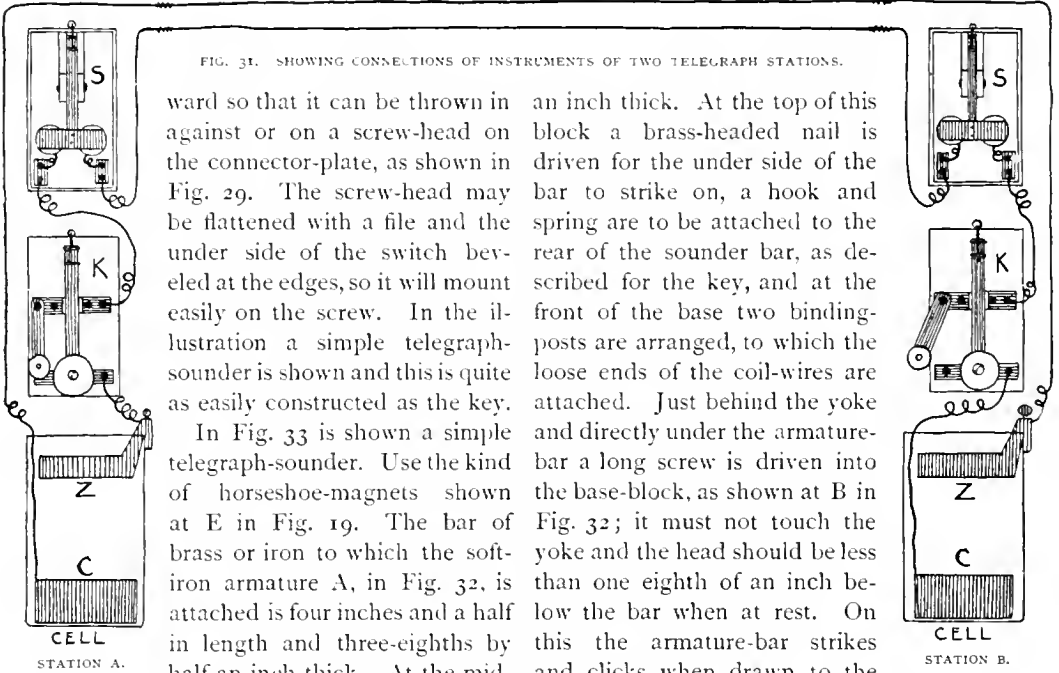

FIG. 30. DETAILS OF TELEGRAPH SOUNDER AND LINE INSULATOR.

plate and the connector-posts at the opposite side of the key base so that if necessary the circuit may be closed, or an arm may be caught under the screw at the L plate and brought for-

FIG. 31. SHOWING CONNECTIONS OF INSTRUMENTS OF TWO TELEGRAPH STATIONS.



ward so that it can be thrown in against or on a screw-head on the connector-plate, as shown in Fig. 29. The screw-head may be flattened with a file and the under side of the switch beveled at the edges, so it will mount easily on the screw. In the illustration a simple telegraph-sounder is shown and this is quite as easily constructed as the key.

In Fig. 33 is shown a simple telegraph-sounder. Use the kind of horseshoe-magnets shown at E in Fig. 19. The bar of brass or iron to which the soft-iron armature A, in Fig. 32, is attached is four inches and a half in length and three-eighths by half an inch thick. At the middle of the bar, through the side, a hole is bored, through which a small bolt can be passed to hold it between the upright blocks of wood;

an inch thick. At the top of this block a brass-headed nail is driven for the under side of the bar to strike on, a hook and spring are to be attached to the rear of the sounder bar, as described for the key, and at the front of the base two binding-posts are arranged, to which the loose ends of the coil-wires are attached. Just behind the yoke and directly under the armature-bar a long screw is driven into the base-block, as shown at B in Fig. 32; it must not touch the yoke and the head should be less than one eighth of an inch below the bar when at rest. On this the armature-bar strikes and clicks when drawn to the magnets, for the armature must not touch the magnets, otherwise the residual magnetism would hold it down. This screw can be ad-

justed to produce the proper click. When the sounder is at rest the rear end lies on the brass tack and the armature is about quarter of an inch above the magnets. In Fig. 31 are shown the connections of two telegraph stations.

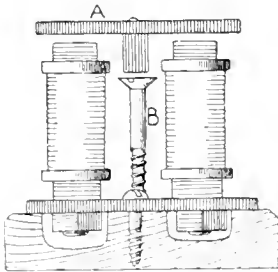

FIG. 32. DIAGRAM OF A TELEGRAPH-SOUNDER.

and at the front end two small holes are to be bored so that the armature can be riveted to it. A small block of wood is cut, as shown in Fig. 30, against which the two upright pieces of wood are made fast. This block is two inches and a half long, one inch and a quarter high, and seven eighths of an inch wide. The laps cut from each side are an inch wide and quarter of an inch deep to receive the uprights, which are an inch wide and quarter of

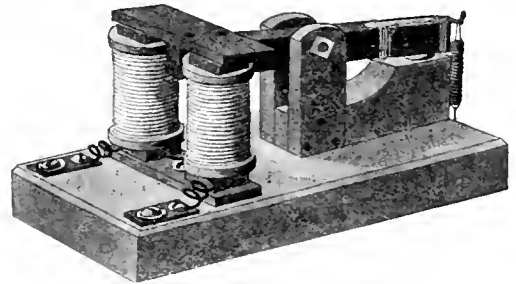

FIG. 33. A TELEGRAPH-SOUNDER.

JEREMI' AND JOSEPHINE.

A Dialogue.

BY LAURA E. RICHARDS.

As Jeremi' and Josephine
Were walky-talking on the green,
They met a man who bore a dish
Of — (anything you like to wish!)

They stared to see the man so bold;
They really thought he must be cold,
For he was clad, though chill the day,
In — (anything you choose to say!)

The man returned their stare again;
But now the story gives me pain.

For he remarked in scornful tone —
(I'll let you manage this alone!)

And there is even worse to come;
The man, I've been informed by some,
Inflicted on the blameless two —
(I leave the punishment to you!)

This simple tale is thus, you see,
Divided fair 'twixt you and me;
And nothing more I've heard or seen
Of Jeremi' or Josephine.



AN OCTOBER DAY IN THE FIELDS.

AFTER BURGOYNE'S SURRENDER.

BY KLYDA RICHARDSON STEEGL.

HERE is a little story which may interest patriotic young readers of *ST. NICHOLAS*.

After General Burgoyne had surrendered to General Gates he was, as you know, conducted to Boston, whence he sailed to his English home. The failure of the British arms was a terrible disappointment to him, and although he was too proud to show what he felt, the ride down from Saratoga to Boston must have been a hard journey for him, with days and nights filled with bitter recollections and regrets.

But he was escorted with all the honor possible, and every courtesy was shown to him. General Gates and his staff were gentlemen, and Burgoyne was treated as little like a prisoner as was consistent with the situation. He had a good horse to ride, and, wherever the little company of officers stopped for the night, he was given the most comfortable room and the best of everything that the house could afford.

Naturally, General Burgoyne was grateful for this consideration, and probably when he sailed from Boston he carried with him most pleasant memories of the men who had been his guards and yet friends. Chief among these was a young officer, Major Seymour. He was a member of General Gates's staff and a friend of Washington. Although at the time of General Burgoyne's surrender he was not much more than a boy, he was already known as a brave and gallant soldier as well as an accomplished gentleman. In the rotunda of the Capitol at Washington, you will see the picture by Trumbull, one of the early American painters,

of "The Surrender at Saratoga." In this picture there is just one figure on horseback, and that is the young Major Seymour.

He it was who was given special charge of General Burgoyne, and who brought him safely to Boston. On the road there were plenty of people to stare and jeer at the defeated general, and he was saved from many an insult

only by the watchfulness and care of his young escort. Sometime before there had been a rumor — doubtless a false one — that Burgoyne had said, in jest or earnest, that he would give rewards for all scalps of Yankees brought to him, which remark had greatly infuriated the people who heard of it. So, as he was riding along through the country, an old woman rushed out of a wayside house, and, shaking her fist in the air, shouted toward him, angrily: "Now, now, now! What will you give for your scalps now?"

Before General Burgoyne could reply, Major Seymour drew up his stately young figure, and with the greatest dignity faced the excited speaker.

"Go into your house, madam!" he promptly ordered. Then, with a quick command to his men, the little cavalcade rode on, leaving the old woman in dumb astonishment.

Before Major Seymour and his prisoner parted company at Boston, General Burgoyne presented him, as a mark of appreciation of his kindness and courtesy, with the trappings of his horse. These were carefully treasured by Major Seymour's family for several years. But at last, when his younger brothers were grown up, being



MAJOR SEYMOUR

fond of show and gaiety, they frequently borrowed these valued trappings to use on muster-days, and unfortunately there is nothing left of them now.

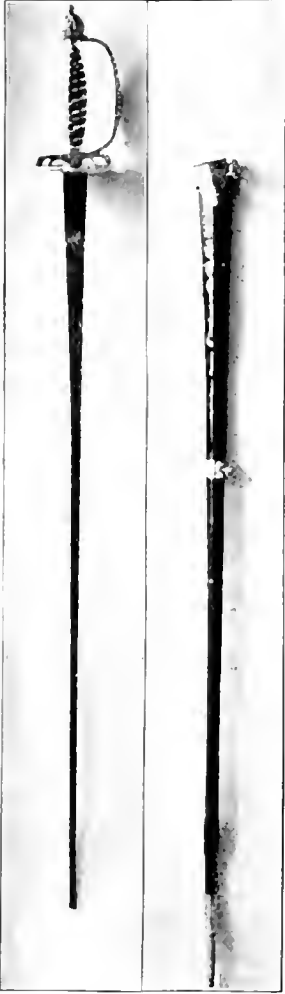

BURGOYNE'S SWORD AND S. ALBANY.

But there exists another relic of this trip of Burgoyne. They chanced to stop one night at the old town of Hadley. Here, desiring to show his thanks for the hospitality offered him, Burgoyne uttered a wish that his sword should be given to his host, which was accordingly done. Strange to say, the sword disappeared — at least from the knowledge of the present generation of the family — until a few years ago. Then, one day, one of the daughters found it hidden away in an old chest, among blankets which had long lain unused. Of course it was immediately brought out and displayed in a place of honor; and not long ago, when there was at Saratoga a celebration of the surrender of Burgoyne, this sword was proudly carried in the procession by the lady to whose great-grandfather it had been given by direction of the general himself.

All this was told to me by the granddaughter of Major Seymour. She has shown me, too, a picture of which I give a photograph. The center, as you see, is a portrait of Washington. Major Seymour told his daughter that this was



PORTRAIT OF GEORGE WASHINGTON, SET IN A WHITE SATIN'S KEEN EMBROIDERED BY MAJOR SEYMOUR'S DAUGHTER

the most satisfactory likeness of Washington that he knew; and he should have been a good judge, as he knew Washington intimately. As I said, the picture is in the center of this piece of white satin; but all the design around it was the work of a little girl of eleven years, and the embroidery is almost as fresh and as delicate as when it was first done, so many years ago. She was Major Seymour's little daughter, and her daughter it was who told me this story of these relics, still in existence, that are connected with the "surrender of Saratoga" on the 7th of October, 1777, just one hundred and twenty-eight years ago this month. As every schoolboy and schoolgirl probably knows, it was one of the most important events of the American Revolution.

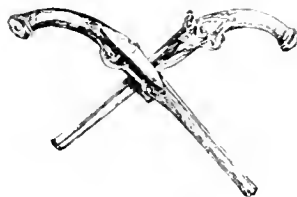

A CHILDREN'S CELEBRATION OF HALLOWE'EN.

BY ISABEL GORDON CURTIS.



THIRTY-ONE children to be entertained — a guest for each of October's golden days — and Halloween to be celebrated! There are easier things to do. Such "stunts" as mirror-gazing at the shivery hour of midnight, as following a thread through a dark cellar, or pulling kalestocks; none of them could be called child's play. Something had to be planned that was different, something entertaining and "Hallowe'eny."

The invitations, which were sent out a week in advance, read as follows:

Won't you come to my Hallowe'en party, from 6 to 9, Saturday, October 31? Please wear real play-clothes.

SYLVIA HALL,
25 Park Avenue.

In the corner of each card was a tiny watercolor sketch — a witch riding a broom, a blinking owl, or a broad-winged bat.

Every response was an acceptance, and straightway preparations for the party began. From a farm-house we drove home one day with a load of cornstalks, pumpkins, and carrots. Everybody in the household who could use a jack-knife was pressed into service. Big pumpkins and little were transformed into lanterns, with faces upon which black or white paint had sketched queer eyebrows or fierce mustachios. They were distributed about the house: tucked among russet oak-leaves and green pine-boughs on each mantel, set lantern-fashion on a newel-post in the hall, or hung here and there from overhead grilles. Cornstalks were stacked beside a fireplace at a safe distance from the fire, and the house was lit dimly by pumpkin-heads or candles set in hollowed carrots.

The dining-table was set with a group of carrot candlesticks and bowlfuls of apples, nuts, grapes, and candy. Upon a fat pumpkin was

perched a Hallowe'en witch holding a handful of raffia, which came from the mouth of a grab-bag. In her black gown, peaked hat, and flying red cloak, with a veritable broomstick in her hand, she was the star of indoors. On the lawn, ready to offer a welcome to every guest who arrived, was a greater star, a life-size witch, with a pair of twinkling red eyes which could be seen two blocks distant. Her framework was a rough wooden cross with one end hewn to a sharp stake which was driven into the ground. Pillows were tied about her lath-like form for shapeliness, while her garb was a night-gown. The pumpkin-head was of noble proportions, the hair was a bunch of black raffia,



"UPON A FAT PUMPKIN WAS PERCHED A HALLOWE'EN WITCH."

and over it perched a lordly hat with a peak nearly a yard high, wide brim, and a crisp scarf of orange-colored paper tied in a magnificent bow at one side. The head was nailed securely to the framework, and inside the can-

dles flared safely, for the witch's cap was lined with asbestos. That she made a hit would be praising her mildly; if her feet had not been securely planted in the earth she might have been tempted to curtsy from the attention she received.

When fifteen small girls filed downstairs, led by their young hostess, they were blindfolded one by one and each played a game of blindman's-buff with the boys in the hall, the one who was captured being her partner for supper. It shattered in an instant the ice which has always to be broken at a children's party. The crowd watching blindman's-buff began to shriek with laughter which grew to genuine hilarity when the sixteenth girl chased the sixteenth boy into a corner. There was a hungry rush at half-past six for the dining-room and parlor where eight small tables were set, four children being seated at each. The supper was a simple one, consisting of tongue and chicken sandwiches, with stuffed potatoes, baked apples with whipped cream, gingerbread men, chocolate, nuts, and grapes.

When the evening's fun began, a jolly young aunt was appointed referee and recorder in the various games. The first part of the program was held in the kitchen while tables were being cleared and dishes carried to the butler's pantry. There was, of course, a tub filled with lukewarm water (it was too chilly a night for a cold plunge), and in it floated a score of rosy apples. Bobbing for them was no end of fun, and the first youngster clever enough to bring one up in his or her teeth was given the first place on the list of honor, which meant later the first chance at the grab-bag.

An apple tied to a string was swinging in a doorway—it got bitten at last—then fifteen minutes were spent over what the small hostess called "candle-boats." It excited curiosity enough when there was handed about a plateful of walnut shell-halves. Each one was numbered on the bottom with India ink, then into it had been poured a spoonful of paraffin. In the center stood a bit of oil-soaked cotton string to make a wick. The children, each one keeping in memory the number of his walnut-shell, crowded about the tub on the kitchen floor, and on its waters was launched a fleet of burning candle-boats. All sorts of exciting ad-

ventures befell them: they bumped into each other, one or two were capsized, some took fire and burned up, while a few sailed on serenely with their little candles burning up the last drop of grease. The last survivor was inspected for its number, then its owner's name went third on the roll of honor.

There was no greater fun during the evening



"BIG PUMPKIN LANTERNS WERE DISTRIBUTED ABOUT THE HOUSE."

than a "peanut carry." The boys chose partners and were ranged in two lines from the dining-room to the parlor. At the end of each line was a table; one held a big basket of peanuts, beside the other stood the umpire, with her pencil and paper. On it was a wooden bowl and two plates. When the umpire called a girl's name she and her partner walked down the center to the farther table. Covering the backs of their hands with all the peanuts they could hold, they carried them to the other table, where they were counted. It sounds like an easy task, but the winner had only seven or eight peanuts to his credit. When the children began to giggle, when hands grew shaky, or a walk quickened into a run, the peanuts went tumbling everywhere to the delight of the onlookers.



"UPON A FAT PUMPKIN WAS A HALLOWE'EN WITCH HOLDING A HANDBL OF RAFFIA, WHICH CAME FROM THE MOUTH OF A GRAB-BAG."

There was a game of bean-bags, then a spirited soap-bubble contest. For this partners were drawn again and a ribbon stretched from end

to end of the room, with boys on one side of it and girls on the other. It was played almost like a tennis game, a girl blowing a bubble to her partner, who wafted it back. The contest went down the line, and the children who kept a bubble floating for two minutes won. At last thirty-two names were down on the referee's list and everybody gathered about the grab-bag in front of the witch-doll, who yielded up her reins of raffia. Each boy and girl, according to his or her place upon the list, pulled at a black or an orange-colored strand of raffia. One jerk brought out a bundle wrapped in tissue-paper—and such queer things were unwrapped, velvet cats and china elephants, feathered roosters or tiny dolls, old women who nodded their heads, and old men who winked their eyes, long-tailed mice, or fat little owls, and Japanese novelties without end.

What a stampede there was down cellar when the jolly aunt appeared with a corn-popper, tin pans, and a package of popcorn. Upstairs they came again presently with half a bushel of hot, snowy-white kernels. Then with bowlfuls of popcorn and peanuts they made a circle about the jolly aunt, who announced that the last half-hour was to be devoted to something very weird and "Hallowe'eny." She sat before a low table chanting softly, while into a saucer she tossed a tablespoonful of salt and poured alcohol upon it from a silver flagon. When she touched it with a match it blazed up



"THE WITCH-LADY ON THE LAWS"

in a blue uncanny flame. Then she began in a slow, deep voice:

"Little Orphan Annie's come to
our house to stay!"

She had scarcely reached the last verse when the saucer lamp flared strangely and went out. The reader lit it again, with her salt and alcohol, and recited:

"All around the house in the jet-black night,
It stares through the window-pane."

but the light went out as she whispered slowly,

"All the wicked shadows coming tramp, tramp, tramp!"

There followed Eugene Field's ghostly "See-in' Things," with its "scary" refrain. But as

she ended the last stanza, the lights suddenly blazed up, real electric lights instead of tallow dips in carrot candlesticks, and the clock struck nine. There was a scurry upstairs for warm caps and coats. "Good nights" were said, not only to the little lady hostess, her tall mother, and the jolly aunt, but to the witch-lady on the lawn, whose round eyes still glowed. Her black raffia hair was blowing across her pumpkin face; she could not very well push it aside, for her arms were stretched out stiffly and her back would not bend.

It had been a very jolly Hallowe'en; even the witch-lady seemed to acknowledge it the next morning, when her head was carried down cellar and her queer wooden leg bumped its way up the attic stairs.



A HALLOWE'EN PROCESSION. LITTLE SANDY IS BEING "HAZED," BUT HE HASN'T FOUND HIS "PUMPKIN" YET.

Nature and Science For Young Folks

EDITED BY EDWARD F. BIGELOW.

October is the opal month of the year. It is the month of glory, of ripeness. It is the picture month.
—HENRY WARD BEECHER.

MOTH-MULLEIN
TURTLE-HEAD.

OVERLOOKED BEAUTY AND INTEREST.

IN every season there is danger of overlooking the quieter, less familiar attractions.

In October, especially, our interest is taken up with the well-known fruits and nuts, with golden-rods, clematis, and milkweed-pods. Our admiration is aroused anew each year by the display of autumnal coloring; but the naturalist is always rewarded by looking closer and seeking out objects less popularly known.

The horse-balm decorates the moist, shady woods all through the summer with the bold freedom of its wide-spreading foliage, and in August, when the terminal clusters of small yellow flowers open and sway lightly above the broad leaves, the plant becomes an object of satisfying beauty. These flowers continue to bloom even into October, and

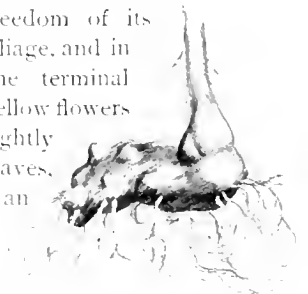

ROOT OF HORSE-BALM OR STONE-ROOT.
Stony in appearance and hardness.

add to the spicy odors of the autumn woods the richness of their lemon-like fragrance. Another common name for this plant—the stone-root—is very appropriate as we can readily discover by attempting to cut through the root with a knife, when it will be found of surprising hardness.

We will find the slender stems of the moth-mullein bearing its white or yellow flowers with their purple centers in quite different situations, along the sandy roads or in old, neglected fields. So tolerant is this plant of dry, thin soil that I have often found it growing along the edges of macadam roads, where it seemed able to find nourishment and a sufficient foothold. Although a frequenter of highways it always maintains a fresh and cheerful appearance, for after the flowers have bloomed the yellow corolla becomes loosened at the base and drops off, while the bud next above it on the stem spreads open its unblemished petals.

Along the swamps and brooks the turtle-head or snake-head will be found in company with the closed or blind gentian. Both of these flowers are certainly striking in form and color, but they present a very uninviting front to the insect world, and only the vigorous efforts of

the bumblebee are able to prevail against their inhospitable doors. He gains an entrance and is dusted by the pollen-grains, which, as he enters another flower, are brushed off on its stigma, and the plants are thus cross-fertilized.

There are two other flowers in bloom in October which are interesting, and belong to the "overlooked" class, the Deptford Pink and the Herb Robert, which has an interesting method of scattering its seeds.

Even in the lives of our most familiar plants there are interesting phases which are often missed.

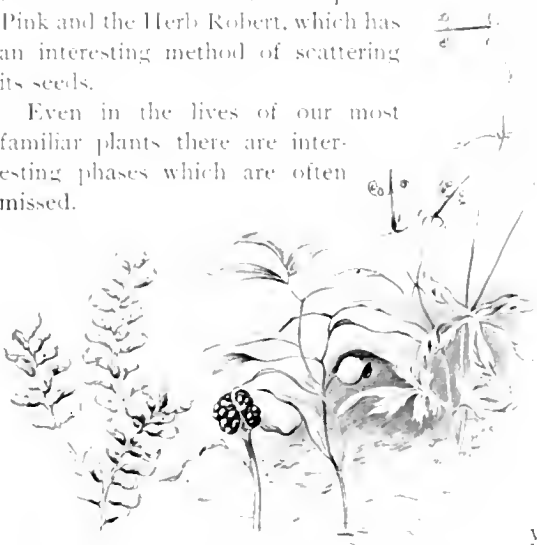

THE UNFAMILIAR SEED-RECEPTACLES OF WELL-KNOWN PLANTS.
Wood-betony, jack-in-the-pulpit, bellwort, and wild geranium.

It is strange that we are in the habit of studying only one or more phases of some plants; as, for instance, the flower of one, a peculiar tendril, stem or leaf of another, and the fruits of others.

Let us, as naturalists, try to know the full life history of at least a few plants.

Do we know the fruit and seeds of the bloodroot, the jack-in-the-pulpit, bellwort, wood-betony, and wild geranium? Very interesting also are the seeds of the fireweed and strawberry-bush, both fully formed now and worthy of careful examination. Even with eyes reinforced by expectation many humble but beautiful growths will escape our notice, but later we will see them, when the first storm of winter has fallen; then, each delicate detail will be disclosed in exquisite perfection as they stand out in sharp contrast against the white background of snow.

HOWARD J. SHANNON.

"BAYBERRY-DIPS" FOR THE CHRISTMAS-TREE.

"TAKE these two 'bayberry-dips' home to your little daughter," said a lady in Pawtucket to me early last autumn, "and tell her to keep them till Christmas and put them in a hanging holder on her Christmas-tree."

And when I gave them to Pearl she inquired at once, as I suppose many St. Nicholas young folks will do when they see the heading to this article, "What are bayberry-dips?"

"I want to know, too," exclaimed another member of the family. "I saw an advertisement the other day in a magazine 'old-fashioned bayberry-dips, fragrant and appropriate, for the Christmas-tree'—what are they, anyhow?"

"Bayberry-dips! Don't you know what they are? Why, grandmother made them many a time when I was a boy. But that was years ago, and many things familiar to the young folks at that time seem strange to the young folks of the present. Bayberry-dips, or candles, most fragrant, delightful, and appropriate to the Christmas-tree, seem to be as completely forgotten as are certain flowers of our grandmothers' gardens. But some of the good old customs and things are coming into use again. Bayberry-dips are the candles that



"TO GATHER THE BERRIES IN OUR GOLDEN SUNSHINE WAS THE VERY FIRST TRY OF BERBERRY-DIPPING."

grow on bushes; at least the wax from which they are made grows on bushes. The berries

are on the twigs, and the wax is on the berries, until we take it from these dry "drupes," and



BERRIES ON THE TWIGS.

THE BAYBERRY-BUSH.

use it for the mild and beautiful light, and the delightful fragrance of the smoke from the smoldering wick. When these bayberry-candles were in common use, in the old time, long ago, it was a frequent custom of even the sedate and courteous young ladies of the company to run unexpectedly to the "light stand," and with a laugh and a quick puff of the breath, to blow out the flame, so that their friends might enjoy the fragrant incense that curled to the ceiling in the smoke of the dying wick. Pretty young ladies, a pretty flame flickering at the tip of the candle, a ripple of laughter, a quick puff, a wave of perfume, through the room—does n't it suggest a beautiful picture?

Of the shrubs that bear these wax berries, Robert Beverly says in his "History of Virginia":

At the mouths of their rivers, and all along upon the sea, and near many of their creeks and swamps, the myrtle grows, bearing a berry of which they make a hard, brittle wax of a curious green color, which by refining becomes almost transparent. Of this they make candles, which are never greasy to the touch and do not melt with lying in the hottest weather; neither does the snuff of

these ever offend the sense like that of a tallow candle, but instead of being disagreeable if an accident puts the candle out, it yields a pleasant fragrance to all who are in the room, inasmuch that nice people often put them out on purpose to have the incense of the expiring snuff.

What more appropriate for illuminating a tree at Christmas or more delightful in a room warmed by the logs of the old-time fireplace, than to have it lighted by bayberry-candles? If we could manage the young people, and keep them quiet long enough for us older "young persons" to look at the bayberry-flame and to dream a little! But the extinguishing puff is easily made; the young are active and quick in their movements; the bayberry-smoke is delightful; to blow out the candle is—but you know how that is.

"Why can't we young folks make some of these candles?" inquired Pearl.

"You can, you may, we will." And we so greatly enjoyed the work and the play, that I want to tell other young folks how we did it, and to give them some facts of interest in regard to the shrub that supplies the wax berries.

The bayberry-shrub, or -bush, is found in abundance in the sandy soil along the Atlantic

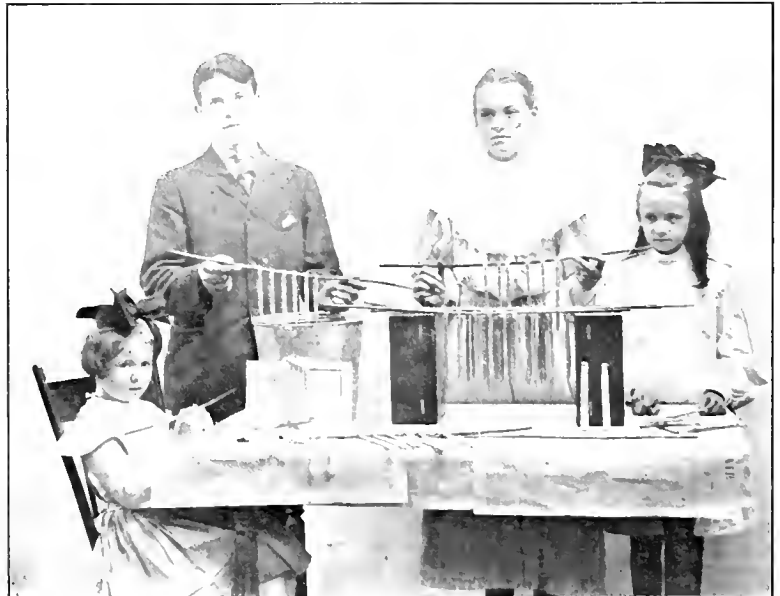

MAKING THE BAYBERRY-DIPS.

Winding wicking
on the rods.

Dipping in the
wax

Placing the rods on a support for
the layers of wax to cool.

Trimming the
candles.

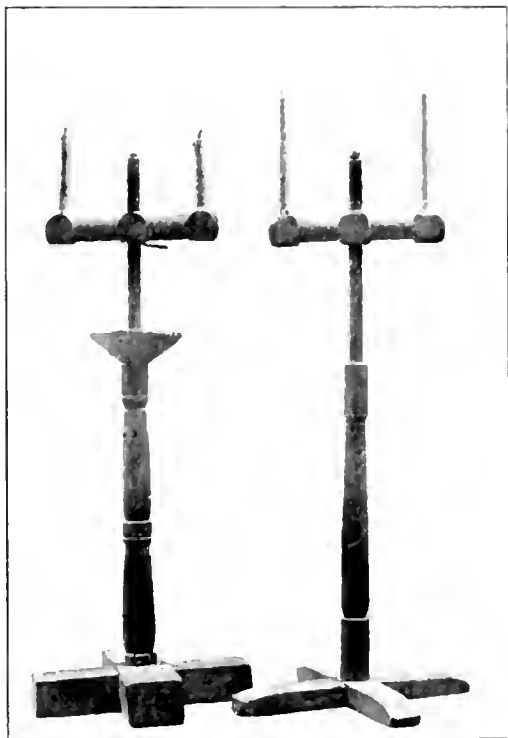

ANCIENT FORM OF STAND FOR CANDLES.
Literally a candlestick—all made of wood.

coast, from Nova Scotia to Florida and Alabama and also on the shores of Lake Erie. It usually grows to a height of from three to eight feet, and is reported to grow, at times, in favorite localities, as high as thirty-five feet. The small nuts are grayish in color and so thickly coated with a fragrant wax, that they are sure to attract the attention of any one, especially if he has come from a place in which the plants are not found. He will without fail say, "Oh, my! What are these things? I have never seen berries like them."

Two of their interesting habits are that they may continue to cling to the branches for two or three years, and are in their best condition for candle-making in October, especially after a few frosts have touched them.

On a hillside the young folks on a brilliant October afternoon found a beautiful cluster of the bushes. To gather the berries in the golden sunshine was the very poetry of berry-picking, in those waves of exquisite odor from the crushed fruit and the bruised and broken leaves

and twigs. What better outdoor music could we have had than the tinkling of the harvest on the sides of our tin pails?

At home we found that the contents of all the vessels filled two large ones. Water was poured on the berries and set on a stove to boil. As we stirred them into the hot water, the perfumed steam made the room fragrant, and the myrtle wax floated to the surface in a layer of delicate green. This was skimmed off, put into another pail, and again brought to the boiling-point and finally strained. A little ordinary tallow was added so that the candles should not be too hard. Ordinary candle-wicking was twisted around some old-fashioned candle-rods and then the wicks were dipped in the pails of water warm enough to melt the wax which forms a layer varying in thickness from a half-inch to two inches. The water and melted wax must not be too hot. Much depends on this, for a temperature a little too high melts the wax from the wick as fast as it is added. We found that it was best to keep the heat as low as possible, and yet hold the wax liquid. Candles, whether of bayberry, or of ordinary tallow, or of any kind of wax thus hand-made by repeated dippings, are known as "dips," and are regarded as the most desirable form.

"These don't look like the candles we buy at the store," said Jennie, as she examined them with a critical eye.

Then I explained that we had gone back in time to almost the primitive form of a light-giving medium, or just the next step ahead of a wick in oil, or in melted wax or tallow in a dish. It is probable that our ancestors regarded dipping as a marvelous step in advance of the primitive floating wick. Then what an age of progress it must have seemed when someone invented a mold in which to form them! What a labor-saving invention! What a brilliant mind it must have been to think of that!

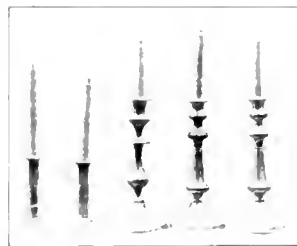

ONE OF THE LATER FORMS OF
"CANDLE-STICKS."
Made of metal.

The quantity obtained from a bushel of bayberries varies with the time of gathering, the average being from four to five pounds. Men do most of the collecting, as it is hard and wearisome work. They dress in the oldest and most worthless clothes at their disposal, wear heavy gloves to protect their hands from the berries, and suspend a pan by a rope from the neck. The top of the bush is seized, rubbed once or twice so that most or all of the berries shall fall into the pan. To make the wax clear and free from dirt, the operator must deal with large quantities, frequently averaging thirty bushels a day. The output of wax for a season has been as high as three tons and as low as five hundred pounds. This year there is only about half a crop of berries.

The wax is too expensive to be used alone. It is therefore generally added to other materials to harden them, and to make the candle last longer than it would otherwise do.

Charles Sanders of Westminster, Connecticut, writes:

I have made bayberry wax for several years. In one year I made seven tons. It requires about two hundred and eighty-five bushels of the berries to make a ton of wax, or about seven pounds to the bushel. To separate the wax, I first place the berries in a large set-kettle with water and apply heat until the water begins to boil. I then dip the berries into a vat about as large as a barrel, and with a press having a four-inch screw, to which is applied a pressure of about one hundred tons, the hot wax is separated, and runs into a barrel placed to receive it. From this it is dipped into pans and allowed to cool. I have had no experience with the making of candles.

The shrub is a member of a fragrant botanical order known to students as the *Myricaceæ*, or the sweet-gale family, and includes bayberry or wax-myrtle, sweet fern, and sweet gale.

The shrub thrives the best near the seashore, and withstands the ocean winds and storms better perhaps than any other shrub. For this reason it has in recent years been brought into prominence in laying out the grounds around many seashore residences. It is decorative, sweet, and intensely hardy, and will make green and beautiful what would otherwise be an almost barren, sandy, or rocky field.

From an entirely different—one might say "sentimental"—point of view the products of the shrub have also in recent years been coming into favor in revival of old-fashioned methods.

THEY LIVE IN TUBES.

THEIR is a curious group of worms inhabiting the seashores, which attach to themselves, along the length of the body, bits of shell, sand, and minute pebbles, thus forming a sheath, a tubular house into which they may retreat. From this funny chimney—like a mineral rag-carpet—the worm expands its breathing organs



THE TUBICULA.

In its tube of bits of shell, sand, and minute pebble.

at the top where a beautiful waving bush of flesh-colored or scarlet tentacles or gills are seen moving softly in the clear water. The worm is two to four inches long, of a pale-red tint, and with markings on the back like lace-work. The striking *Terebella* of the North Atlantic coast is common among and under rocks, and on muddy shores; and nothing will surprise the strolling naturalist more than this gay and ornamental worm in its quaint self-made home.

L. P. GRAYLACAP.



"WE WILL WRITE TO ST. NICHOLAS ABOUT IT."

HOW A SQUIRREL ESCAPED FROM A CAT.

PHILADELPHIA, PA.

DEAR ST. NICHOLAS: I enjoy the Nature and Science Department very much and I would like to tell you what I saw a few months ago. I saw a little gray squirrel do a very plucky thing. The first time I saw him he was sitting on a high board fence not far from a cat. He had slowly backed up till he reached a brick wall of a house. Here he stopped, for he saw the cat would have all chances if he leaped down. When he saw that the cat was slowly creeping along the fence



"THE LITTLE FELLOW HAD SPRUNG DOWN BELOW THE CAT AND WAS CLINGING TO THE BEADING ON THE FENCE."

(Sketched by the writer of this letter.)

toward him, he ran right at her and he did n't stop until he was within a few feet of her. The cat was very much startled at this, but she soon recovered and made a spring. It seemed as though for a minute they stood there and fought. But the next moment the little fellow had sprang down below the cat and was clinging to the beading on the fence. Then, with another quick movement, he passed her and sprang to the top of the fence again, but this time behind the cat. After running along the fence for some way, he found it would have been better if he had sought safety in the willow close to the fence. He ran back just in time to keep himself from the cruel claws of the cat.

Yours truly,

HAROLD PURVES MURPHY (age 12).

WOULD A FRESH-WATER OCEAN FREEZE?

ROCKAWAY, MORRIS COUNTY, N. J.

DEAR ST. NICHOLAS: Will you tell me, if the ocean did n't have salt in it, would it freeze or not?

Yours truly,

EDITH A. HARCOURT.

If the ocean did not have salt it would freeze somewhat more readily than it does now, but there would be no very marked difference. The ocean is prevented from freezing not so much by its salt as by its size and by its commotion. On account of its size, large portions

of it extend into warm climates at all seasons, and by reason of its great depth it is a vast storehouse of heat. Its currents distribute much warm water among the cold.

PROF. JOHN F. WOODHULL.

SHELLS AND SAND HELD TOGETHER BY "THREADS."

WINSLED, CONN.

DEAR ST. NICHOLAS: While at the sea-shore I picked up a bunch of small shells and pebbles which seemed to be held together by something hidden among them. I am sending the specimen with this letter. Will you please tell me what it is that fastens them in this way? I am very much interested in the Nature and Science Department of ST. NICHOLAS. It cannot help being of great benefit to all lovers of nature.

Your interested reader,

GLADYS M. MANCHESTER (age 13).

Many shell-animals attach themselves by a byssus, composed of silk-like "threads," to



PEBBLES AND SHELLS HELD TOGETHER BY "THREADS."
(Drawn from specimens sent by the writer of the letter.)

stones, sticks, and other foreign objects. Examine these threads carefully. They are elastic, and it takes a strong pull to break them.

"BLUE-TAILED LIZARDS."

COLUMBIA, S. C.

DEAR ST. NICHOLAS: The other day I saw two lizards near the road. They were about ten inches



THE BLUE-TAILED LIZARD.

long and had four legs. Their bodies were green on top and white underneath, and they had bright red heads. A negro called them scorpions, and said that one would jump six or eight feet and kill a man with his bite. I know they were not scorpions, and I want to know their real name.

ALAN DOUGLAS MERRILL.

The specimens were "blue-tailed" lizards (*Eumeces quinque-lineatus*), a species that is black, with longitudinal yellow stripes and a brilliant blue tail when young, but becoming brownish, losing the stripes and blue of the tail, and acquiring a bright red tinge on the head when fully adult. They are commonly—when adult—known as scorpion-lizards and thought to be very hostile and poisonous; however, they are very timid and entirely harmless.

RAYMOND L. DUMARS.

A QUESTION AS TO ELECTRICITY.

NEW YORK CITY.

DEAR ST. NICHOLAS: Will you please tell me to what kingdom electricity belongs?

YOURS TRULY, FREDERIC D. GRIMKE.

Electricity is not regarded as a substance, although our language concerning it might very naturally lead persons to think so. We talk about its flowing in a wire, just as we speak of light streaming in at a window, or of thoughts flowing in a channel. It is manifestly figurative speech, but it seems to be necessary. *Matter* is usually divided into three kingdoms, but *forces* are not.

J. F. W.

DO BRANCHES ARISE IN THE HEART OF TREES?

PHILADELPHIA, PA.

EDITOR OF ST. NICHOLAS: I am sending you a section that I cut from the limb of a tree in Maine. The center was soft, and when I poked it out with a stick I found five hard cores like the spokes of a wheel. They seemed to be opposite the places where branches had come out of the bark. Will you please tell me what kind of a tree this is, and if all branches go to the center of a tree like this? Your interested reader,

ROBERT VAN DUSEN.

All branches do not reach to the center of a tree, although the condition referred to is not uncommon. The young twig sent out a whorl, or encircling cluster of small branches, which were of course on the outside of the branch that bore them. The wood of the branch grew rapidly, and as it continued to increase each year, it soon began to grow around the attached ends of the encircling cluster, and in the course of time it had so increased that it actually surrounded and partly buried the whorl of small growth. The interior wood decayed and became so soft that when the tree was cut it was easy to push out the softened center, and so leave what were at first the starting-points of the whorl of young branches. In a word, the branch grew around what became hard, spoke-like cores, rotted away, and left



"A SECTION THAT I CUT FROM THE LIMB OF A TREE."

the cores in place as my correspondent found them. The tree is probably the white pine.

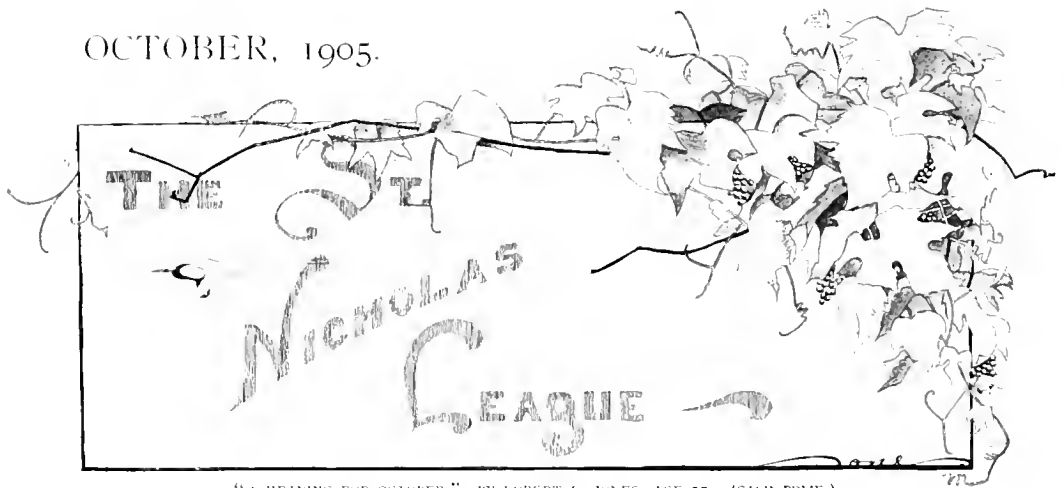

"A HEADING FOR OCTOBER" BY ROBERT E. JONES, AGE 17. (CASH PRIZE)

"OCTOBER burns upon the lands,
Our drowsy, idle days are passed;
The goldenrod, a wanderer, stands
To make the gates of summer fast."

THOUGH for most of us the vacation days are ended, we might call this a League vacation number. The poems, pictures, and stories are all of outdoor life; and very good ones they are—inspired, no doubt, by the season and the surroundings incident to their production. Wherever we were,—at the sea shore, in the woods, abroad, or on the farm, it is quite certain that most of our League members had a pleasant time; and as the shorter days close in, with less of freedom and more hard work, the days behind will grow ever brighter, until memory puts about them such a halo as will make us wonder why we did not really prize them more when they were slipping by.



"VACATION DAYS," BY SUSAN T. SWEETSER, AGE 14. (GOLD BADGE.)

For it is the "light that never was on sea or land" which illumines the past. Viewed in it, the smallest joy becomes beautiful, and new and wonderful charms, unseen at the moment, grow and take on a rare coloring as the weeks and months drift away from us and become a part with the days that are no more. Oh, it is not only the summer and vacation days that beam with new light and glory as they recede from us. To-day, now, this very hour, if we live it worthily, and catch even a glint of its joy in passing, may shine out fair and un fading in the light of other years. Too many of us hurry over the present, looking always to a joy just ahead, or turn back with sadness to the rare days we did not prize. We forget that the passing moment may be quite as beautiful, and that it is ours.

It is well to look to the future with its promises, it is sweet to look at the past with its memories, but it is more important to live each passing moment, with that appreciation and understanding, and with that kindness of spirit and that gentleness of thought and deed, that shall make the present, and every part of the past, as fair to look back upon as the sweetest of our vacation days.

PRIZE-WINNERS, COMPETITION No. 70.

IN making the awards, contributors' ages are considered.

Verse. Cash prize, **Marjorie R. Peck** (age 14), Oxford, Conn.

Gold badge, **Marie Wennerberg** (age 15), 47 Milford St., Boston, Mass.

Silver badges, **Eleanor Johnson** (age 7), Hotel Victoria, Chicago, Ill., and **Adelaide Wilmer** (age 13), 3000 Clifton Ave., Wallbrook, Baltimore, Md.

Prose. Gold badges, **Miriam C. Alexander** (age 12), 2328 Coliseum St., New Orleans, La., and **Margaret Douglass Gordon** (age 13), 330 E. Beverly St., Staunton, Va.

Silver badges, **Dorothy C. Cross** (age 16), 38 Burr St., Rochester, N. Y., and **Madeline F. H. White** (age 14), 9 Clapp St., Worcester, Mass.

Drawing. Cash prize, **Robert E. Jones** (age 17), Box 61, Milton, N. H.

Gold badges, **Miriam H. Tanberg** (age 8),



"VACATION DAYS" BY W. L. IRISH, AGE 10. (GOLD PRIZE.)

665 Pine Grove Ave., Chicago, Ill.; **Helen G. Waterman** (age 14), cor. Hawthorne and Albatross Sts., San Diego, Cal.; and **Jennie Fairman** (age 14), Wakefield, Kan.

Silver badges, **Seth Harrison Gurnee** (age 16), 419 Tompkins Ave., Brooklyn, N. Y.; **Helen M. Copeland** (age 14), 53 Gray Cliff Rd., Newton Centre, Mass.; and **Marjorie Pope** (age 14), 1793 Beacon St., Brookline, Mass.

Photography. Cash prize, **W. L. Irish** (age 10), "The Hamilton," Morristown, Pa.

Gold badges, **Henry Holmes** (age 16), 601 Masonic Temple, Minneapolis, Minn.; and **Susan T. Sweetser** (age 14), Marion, Mass.

Silver badges, **Helen Parfitt** (age 14), "Lansdowne," St. Helen's Park Road, Hastings, Sussex, England; and **Herbert H. Bell** (age 11), Milton, N. Y.

Wild-Animal and Bird Photography. First prize, "Wild Ducks," by **Hardenia R. Fletcher** (age 14), Accomac, Accomac Co., Va. Second prize, "Florida Gopher," by **William M. E. Whitelock** (age 14), Orlando, Fla. Third prize, "Young Mocking-bird," by **Alice J. Sawyer** (age 9), Wilmington, N. C.

Puzzle-making. Gold badges, **Morton L. Mitchell** (age 16), Orillia, Iowa; and **Florence Cassidy** (age 14), Montour Falls, N. Y.

Silver badges, **Richard G. Curtis** (age 16), 25 Hakes Ave., Hornellsville, N. Y.; and **Herbert M. Davidson** (age 9), 2219 E. 12th St., Kansas City, Mo.

Puzzle Answers. Gold badges, **Albert Ellard** (age 15), 1124 Belford Ave., Brooklyn, N. Y.; and **Margaret Griffith** (age 14), 721 N. Main St., Independence, Mo.

Silver badges, **Dorothy**

E. Hopkins (age 16), 35 Ridgmont St., Allston, Mass.; **Harriet O'Donnell** (age 12), 214 N. Main St., Bellefontaine, Ohio; and **Winfred A. Anderson** (age 8), 1309 Lyon St., San Francisco, Cal.

THE FISH THAT GOT AWAY.

BY MIRIAM C. ALEXANDER (AGE 12).

(Gold Badge.)

"As I lay on my couch almost dozing, weary from a hard day's fishing, a beautiful, shining sprite, flew in at the window and, beckoning to me, said enticingly, 'Come!'"

"Amazed, I asked, 'Who are you?'"

"The Spirit of Prevarication," she replied most seductively.

"What! I cannot go with you, then?"

But I could not resist her charms, and bearing me



"VACATION DAYS" BY HENRY HOLMES, AGE 16. (GOLD BADGE.)

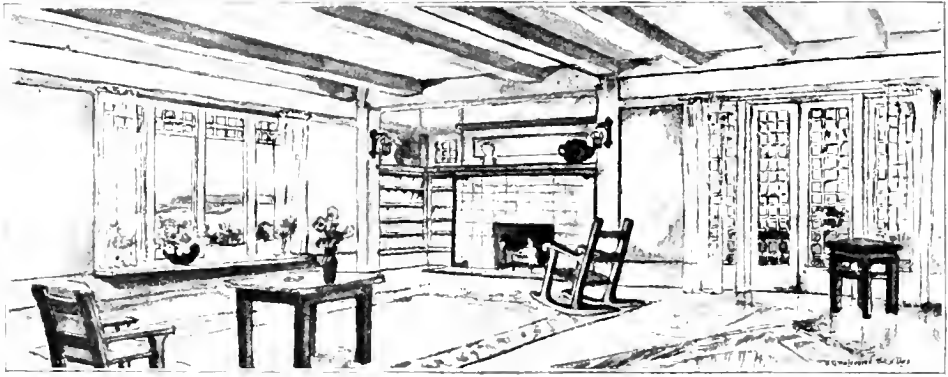

"AN OCTOBER WINDOW-CORNER." BY HELEN G. WATERMAN, AGE 14 (GOLD BAUGE)

tar away over the seas, she set me down on a long, ridge-shaped island slimy and black.

"Look into the clear waters about you," she said.

I looked and saw thousands of fish, the largest and most extraordinary monsters imaginable.

"These were caught," said she, as a school of splendid ten-foot bass, salmon, and mackerel swam past, "by amateur fishermen; and, would you believe it, these fine fifty-pound trout were caught by inexperienced ladies, and these whales by small boys when out fishing—alone," she added meaningly; "while yonder great sea-serpents were captured by inventive sailors." Then lowering her voice to a confidential tone, she added:

"You have observed that there are no unsuccessful fishermen. However empty their baskets may be, their mouths are always full of marvelous tales of what they caught, and how, through some mischance, it got away. Now you have seen what no one else has ever seen—the fish that got away."

"Not even they who caught them?"

"No; with my help they did not need to.

"I created every one of these and I preside over this realm. But here comes one of my finest specimens, that monstrous fish that, before Columbus's day, sailors discovered devouring ships." And there it came, crushing a luscious battle-ship between its huge jaws.

"Where," I demanded, greedy for more wonders, "is that stupendous fish that St. Brandan discovered and mistook for a vanishing island?"

"Directly under your feet."

Instantly the island began to heave and plunge and sink beneath me.

Looking up to the Spirit for help, I saw dimly through her fair exterior the ugly shape of a dragon smiling with pitiless amusement. As I vehemently shook my fists at the treacherous one, the cold shock of the mad waters closing over my head roused me, and looking round, I found myself safe in my bed, mercilessly pounding the pillows.

THE JOYS OF CAMPING.

BY MARJORIE R. FLOK (AGE 14).

(Cash Prize.)

RAIN, rain in torrents!

Fell from a leaden sky,

The east wind blew with fury,

The waves on the lake were high;

The fire sizzled and sputtered,

The air was damp and chill.

Oh, these were the joys of camping!

But we grinned, and bore it still.



"WILD DUCKS." BY HARBENIA K. FLETCHER, AGE 14. (FIRST PRIZE, "WILD-BIRD PHOTOGRAPH.")

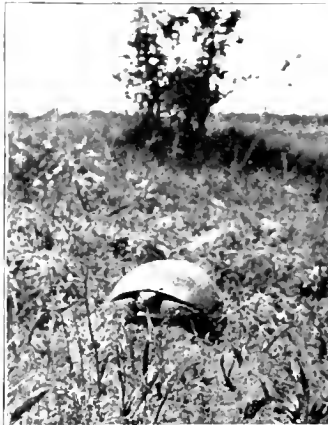

"A FLORIDA 'GOBLIN.'" BY WM. M. F. WHITELOCK, AGE 14. (SECOND PRIZE, "WILD-ANIMAL PHOTOGRAPH.")



"YOUNG MOCKING-BIRD." BY ALICE J. SAWYER, AGE 6. (THIRD PRIZE, "WILD-BIRD PHOTOGRAPH.")

Rain, rain in torrents!

And a night as black as pitch,
The wind shrieked round the cabin
Like a horrid, vengeful witch;
The latch at the door was rattling,
The rain dripped from the sill,
Our blankets were wet and clammy;
But we shivered, and bore it still!



"A HEADING FOR OCTOBER." BY MIRIAM H. TANBERG,
AGE 8. (GOLD BADGE.)

Sun, sun at its brightest!
Shone through the window small,
Making a patch of glory
On the rain-soaked, steaming wall.
Blue were the dancing waters
Of the lake, once dull and gray:
"Hurrah! for the clouds have vanished,
And we'll *really* camp to-day!"

THE FISH THAT GOT AWAY.

BY MARGARET DOUGLASS GORDON (AGE 13).
(Gold Badge.)

TITS is the tale of Rameses, son of Lentulus, fisherman of Alexandria in Egypt in the time of Queen Cleopatra.

Truly, when Lentulus my father died I was but a lad, loving better to spend my days in idleness upon the wharves, diving into Alexandria harbor, and sporting with my companions, than to take up the fishing-net, following my father's trade.

Wherefore, this thing being offered unto me, and savoring somewhat of child's play, gladly I took it.

Now Queen Cleopatra, who then reigned, albeit marvelous fair, yet waxed so great in shrewishness, being troubled by many things, that at veriest trifles she would loudly exclaim, declaring there was no peace for her, and cry out angrily. And especially grew she wroth when, fishing from her barge, she chanced to catch nothing, whereat she blamed those about her. And as fish come always for no one, even queens, her maidens, fearing her much, oft bought fish, the which I, diving, fastened to her net, and she, unknowing, was well pleased.

But these maidens, forgetful of my service unto them, would twit and make mock of me, my garments being tattered and I poor; and I became angry, and yearned for revenge, when I bethought me of a plot. And behold, when next the Queen Cleopatra went a-fishing, her maidens praised her skill to a goodly company, swearing she never missed catch, and I, drifting below, heard all.

And the Queen cast line, and all crowded about her, rendered expectant by her maidens' tales, and she was pleased.

And she drew in line, and lo! never was queen so

wroth, or company so merry, as when she saw a small *wooden fish*, cunningly carved, such as babes play with, and knew she had been deceived, the maidens' faces telling tales.

And below the barge, in my boat, I lay laughing at my revenge.

Far into the sea she flung the bauble, her eyes flashing, and turned on her maidens, whereat I went my ways, judging it no spot for me then.

"CAMPING IN."

BY MARIE WENNERBERG (AGE 15).
(Gold Badge.)

No doubt you've heard of rustic camps
By ocean and in wood,
And pictured to yourself the joy
You'd have there if you could.

But tell me, did you ever hear
Of camping in, not out?
My pa and ma've been doing so—
It's moving they're about.

They tired of our cozy house
And went to see a flat
(The cupboards there are n't big enough
To hold my newest hat).

And now the packing has begun—
When we remember lunch,
We drop upon the nearest trunk,
And sandwiches we munch.



"A HEADING FOR OCTOBER." BY JENNIE FAIRMAN, AGE 14
(GOLD BADGE.)

And papa says we're camping sure—
When he comes home at night,
He sits down on a stool or box
And laughs with all his might.

The furniture is all astray,
It must go in the flat;
But oh, dear me! where *do* you think
Ma'll put my biggest hat?



"VACATION DAYS." BY HERBERT H. BELL, AGE 11 (SILVER BADGE.)

THE FISH THAT GOT AWAY.

BY DOROTHY C. CROSS (AGE 10).

(Silver Badge.)

FISH stories are told about bears, wolves, and many other animals; but this is a *real* fish story, because it is about a fish.

The heroine is a remora. She is a little fish, characterized by having a suction disk on top of her flattened head. This disk or plate holds her firmly to any surface to which she may choose to apply it.

One day, as the remora was making her daily meal off small crustaceans and mollusks, she was frightened almost to death by the sight of an ugly big mackerel swimming for her. She knew that these big fish had a particular relish for small remoras, so she tried to take refuge under an overhanging rock. Soon he nosed her out, and she had to swim for dear life to a near-by clump of seaweed. There, the remora, in company with a couple of little sea-horses, endeavored to conceal herself. Again Mr. Mackerel spied her, and darted at her through the seaweed. Nothing was left for the remora but to take to the open, with the big fish swimming mightily after her. What should she do? He was overtaking her! Suddenly she dived down, then flew up right under



"VACATION DAYS." BY HELEN PARFITT, AGE 14. (SILVER BADGE.)

her pursuer, and clapped her little suction disk on his side so tenaciously that no effort of his could dislodge her.

In this manner the remora lived for many days, propelled through delicious feeding-grounds by her enemy. There came a time, however, when she tired of her host; so, one day, while Mr. Mackerel was dozing, she disengaged herself and ran away.

Thereafter she confined herself to shallow waters near shore, where she knew her enemies the mackerels never frequented. Thus she lived most happily.

"CAMP O' MINE."

BY ADELAIDE WILMER (AGE 13).

(Silver Badge.)

AWAY up on the mountain,
Neath a tall and rugged pine,
I have a little cabin,
And I call it "Camp o' Mine."

It's been there many winters,
When the gray wolves howl and whine;
And the snows drift through the windows
And door of "Camp o' Mine."

Then when again 't is summer,
With birds and bright sunshine,
I mount my horse and gallop
Straightway to "Camp o' Mine."

The thrushes sing and whistle
Their notes so clear and fine,
And the brooklet dances gaily,
When I come to "Camp o' Mine."

HONOR MEMBER.

The words "Honor Member" attached to a contribution mean that the author has already won a gold badge or a cash prize.

TO NEW READERS.

St. Nicholas League is an organization of ST. NICHOLAS readers. It is six years old and contains more than fifty thousand members. The membership is free and a League badge with full information will be sent on application.

CAMPING.

BY ELEANOR JOHNSON (AGE 7)

(St. Nicholas)

WHERE shall we spend our summer,
Now the warm days are here,
Laden with softest breezes,
The loveliest of the year?

Shall we wend our way to the mountain
tops,
And climb the rocky cliffs;
Or seek some shady river,
And drift in our little skiffs?

Shall we wander away to the country,
And recline in hammocks wide;
And read many books in the coolest
of nooks,
By the rippling streamlet's side?

Shall we stray by the mighty ocean,
And dive under the cool sea waves,
Until we can almost fancy
We see the mermaids' caves?

But when we count the pleasures
Of mountain and river and shore,
We think of a plan for the summer
With these joys and many more.

To camp in the heart of a forest
Is the best way found at last;
And our days shall be filled with pleasures
Until camping-time has passed.

THE FISHES THAT GOT AWAY.

BY MADEIRA E. H. WHITE (AGE 14)

(St. Nicholas)

ON a warm afternoon in early autumn a girl sat by a brook, reading. Near by a little boy was baiting a fish-hook. After the baiting was done he sat down by his sister and began fishing. Suddenly he said, "Sister Amy, could n't you please tell me a story while I'm waiting for the fish to bite?"

"Yes, Neddie," replied the girl; "I'll tell you a story about some goldfishes."

"Once upon a time, some goldfishes lived in a large glass globe. The globe stood in a pretty arbor by a brook. There were four canaries in the arbor, and flowers and shrubs grew all around it. It was a beautiful place, but the goldfishes were unhappy.

"Every day they could see countless little fishes swimming and frolicking in the brook. They seemed so happy that the goldfishes envied them and wished that they, too, were free.



"A FENCE A-REAR" BY MARGERY BRADSHAW, AGE 17

They thought it would be much nicer to have a whole brook to play in rather than a glass globe.

"One day a large gray cat came into the arbor and jumped up on the stand which held the globe. At that moment a little girl entered and frightened the cat, who jumped over the globe, knocking it down and smashing it. The water out of the globe, with the little fish in it, flowed down the bank into the brook.

"The goldfishes were overjoyed at their freedom and splashed merrily in the fresh, cool water. They made friends with the fish in the brook and had a very nice time. Just before winter they went down the brook into a lake, and there they had a great many adventures. They were never sorry that they got away from their old home."

Neddie had been so interested in the fortunes of the goldfishes that he forgot his fishing, but now he returned to it. The bait was gone, but there was no fish on the hook.

"Do you suppose that my fish got away too?" said Neddie.

MY CAMP.

BY BESSIE M. BLANCHARD (AGE 12)

(St. Nicholas)

It stands between the tall
pine-trees,

This little camp of mine,
And at the front a rippling
lake

In summer sun doth
shine.

'Tis built of strong, brown
maple logs;

The shade around it 's
deep;

Inside there is a fireplace and
A cot where I can sleep,
I always find it pleasant,

For I always love to see
Nature's ever-changing
beauty

In the haunts of bird and
bee.

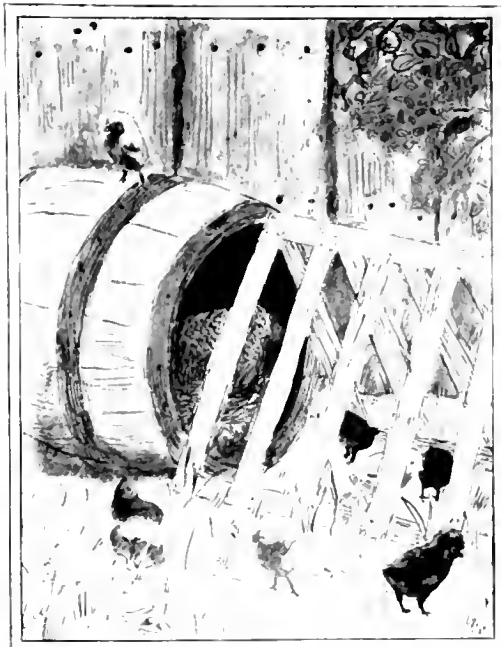

"A FENCE A-REAR" BY MARION K. COBB, AGE 17

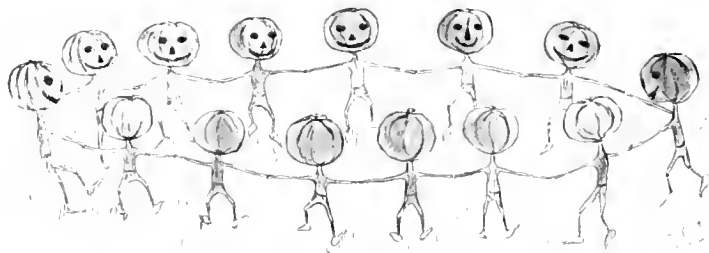

"OCTOBER." BY MILDRED C. JONES, AGE 16.

THE FISH THAT GOT AWAY.

BY LAWRENCE HARGER DOOLITTLE (AGE 13).

(From a Zoological Text-book.)

Piscis magnus, or "the fish that got away," as it is commonly known, is found all over the world. It never fails to take the fisherman's hook, but it has never yet been landed, or even clearly seen. It is well known that it is always too large for a man to carry home, and too wily to be caught. On this account many people do not believe that it exists, but it is well known to all fishermen.

Although all attempts to secure this fish so far have been fruitless, people are still eager in its pursuit, and undoubtedly the natural-history text-books of a few years hence will be able to give an accurate description of this "what-is-it" of the waters.

Frequent glimpses of this fish have been secured by fishermen, but these were too brief to allow of a full description.

There is one established fact, however, and that is that there are no small ones of this species.

A FAIRY CAMP.

BY JESSIE BARKER COIT

(AGE 13).

'T was in a shady nook so cool
I found a tiny camp;
'T was small enough for any
doll,
From flag-pole down to lamp.

The tent was made of spider's
web,

The ropes by him were spun;
The table was a mushroom gray
Brought in from out the sun.

The table was all set for twelve,—
And outside, in the shade,
The queen sat on her throne in
state,

Where she her court had made.

The queen was dressed in cloth
of gold,

Her maids in white and green;

They were all making daisy-chains
To crown her there, I ween.

It was the cutest thing I found
In many a long day;
And I'd go there again, right now,
If I could find the way.



"VACATION DAYS." BY ALICE WAAGESHEIM, AGE 9.

THE CAMP AMONG
THE HILLS.BY MAUD DUDLEY SHACK-
FLORED (AGE 16).*(Honor Member.)*

Now night has come as a
mantle thrown
From the shining crests of
snow,
And the watch-fires gleam
By the silver stream
In the rugged vale below;

While the darkness falls o'er the dreary waste
Of the prairies brown and bare,
And the dead leaves fall,
At the breeze's call,
On the still earth everywhere;

And hushed is the sound of the huntsman's horn,
And his dream with rapture thrills,
While the pale moon keeps
Her watch as he sleeps
Safe in his camp in the hills.

THE FISH THAT GOT AWAY.

(A True Story.)

BY FLORENCE R. I. SMITH (AGE 10).

POSSIBLY one of the largest fish that ever got away was one lost by a gentleman at a lake near my home.

It was such an amusing experience that it may be interesting to the League readers.

The fisherman and a friend, after securing a boat and arranging their poles and tackle, rowed to a part of the lake where they knew the best fish were to be found.

The two men, when they had anchored the boat and cast their lines, waited patiently for some time, almost despairing of a bite. Finally one of them felt a tug at his line and his hopes arose.

The delighted man played the line to secure the trophy more firmly, and soon it appeared to be sulking on the bottom of the pond. That seemed strange. It acted like a salmon; but as salmon are not found in that particular lake, what could it be?

At length, by some peculiar turn of the pole, the line loosened somewhat and the man began reeling cautiously.

After the most strenuous efforts on his part, great was his surprise to see a huge black object rise to the surface of the water, gently fluttering what seemed to be a good-sized pair of wings. To his chagrin, and to the intense amusement of his companion, the fish was found to be an old black umbrella.

In another moment the umbrella got away, as a species of that kind are very apt to do.

IN CAMP.

BY ROSIE GOODWIN, AGE 15.
(See *St. Nicholas*, 1904.)

The beautiful moon, swift sailing o'er
The sky,

Untold upon the earth a silvery veil,
The snowy clouds in silence pass her
By,

Bathed in her gentle light, so soft and
pale.

Upon the rippling surface of the lake

The streaming moonbeams dance in silent glee;
Their laugh, the flashing that the wavelets make;
Their song, the joyous rustle of the tree.

Around about the darksome forest stands,

Each tree with arms extended toward the sky,

As if to seize with out-stretched, eager hands

That milk-white gem from out its place on high.

The fitful wind disporting through the trees,

The whippoorwill's long-drawn
and mournful cry,

The hooting owl, the cricket's chirp
—all these

Soothe the tired camper like a
lullaby.

There by the grassy bank of gleaming
lake,

The snow-white tents like ghost-
ly watchers stand;

Their rustling sides the dreamy
stillness breaks,

The firelight sheds a glow on
every hand,

Sudden a shadow steals across the
scene:

The timid moon behind a cloud
has gone.

The camp-fire flickers, tries to light
the green,

Leaps up—falls back—expires
the camp sleeps on.

THE FISH THAT GOT AWAY.

BY ELEANOR HOUSTON HILL, AGE 11.

(*House Member.*)

Last summer we went
on a fishing-trip to north-
ern Wisconsin. My
mother and father took
turns staying at the camp
with my brother and my-
self. A friend of ours
was with us, but she
nearly always stayed at
the camp. She had said
before we left home that
she would never go in a
boat.

One day my father took
us out in a rowboat, so
that we could fish a lit-
tle. We had persuaded
our friend to go with us.
We had very little luck
until we started home,
when she had a strike.
We were trawling for



OCTOBER

1905.

THE FISH

BY ELEANOR HOUSTON HILL, AGE 11.
(See *St. Nicholas*, 1905.)

muskellunge, and she had never before fished for any
larger fish than brook trout, so of course she thought
she had a big fish. He did not fight much for a muskie,
and she landed him in a few minutes. We weighed
him, and he weighed but three pounds; but as he was
her first muskie we decided to keep him, as she wanted
to have her picture taken with him.

When we landed we washed him by the boat-house,
so that I could photograph him. He seemed lively for
having been out of water so long.

I took his picture, and then we de-
cided to let him go. We put him in
the water by the landing, and watched
him for a few minutes. We then
thought he would not recover, so we
stooped to lift him out of the water,
when he suddenly darted off for the
middle of the lake.

He did not leave his name or ad-
dress, or we might have sent his
photograph to him, so that he could
show it to the other fishes when he
told them about the wonderful adven-
tures of "The Fish that Got Away."

IN CAMP.

BY SARA WARREN WILLET,
AGE 12.

At the o'er the ocean the sunlight is
dying,

And tinges the breakers with
flashes of gold;

Away to the landward stretch forests of fir trees—
The southland is dotted with meadow and wold.

And here on this hill-crest the waters o'er-changing

Our cabin is built of the driftwood we find;

Here, steeped in the twilight, how fair is the haven!

The lapping of wavelets doth quiet the mind.

Throughout the long night, while the planets keep vigil,
The ocean shall soothe us with lullabies sweet;

And when morning rises across the deep waters

Our spirits shall gladly its messengers greet.

Thro' wood and thro' thicker our footsteps shall follow

The pathway of pleasure, the life of the wild;

And Nature shall teach us the knowledge that's sweetest,

In accents like music, in syllables mild.

When daylight is past and the moon rises lovely,

Beside the bright camp fire the wanderers shall meet

And whisper adventures and talk of the forest.

While 'neath us the ocean doth restlessly beat.

THE FISH I DIDN'T CATCH.

BY BERKELEY BARK, AGE 11.

Oh, that fish! Its beauty! its size! There was
never such another; no other ever flashed in the sun as



"OCTOBER" BY EMMA W. BROWNE,
AGE 10.



THE MUSKIE.
(See *Story.*)

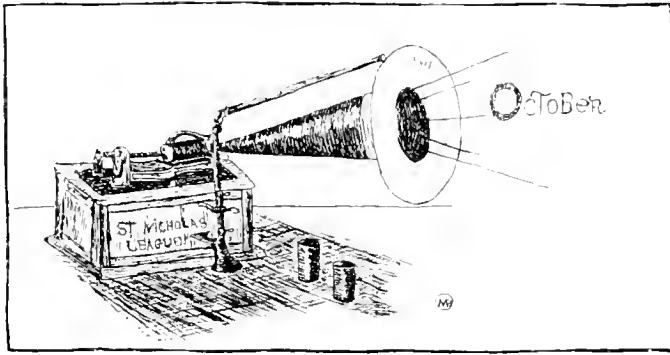

"A HEADING FOR OCTOBER" BY MARJOLIE POPE, AGE 11. (SILVER BADGE.)

it did, no other ever pulled so hard;—but I lost it! I was not a fisherman, I had no right to fish, but I loved to drop my hook into the water and dream and dream while the minnows stole the bait.

So there I sat. The evening sun had changed the lake to a golden floor on which the fairies danced. Fairy music drifted through the air and fairy messengers hurried back and forth across the lake. I reveled in my dreams and lay in sweet content.

Then came a tug, the pole bent as a bow, the fairies vanished in alarum. With one wild pull I jerked, and for a single second there hung in the middle air a perch. One flash from his golden mail and he was gone; a swaying in the reeds, a ripple on the golden path, and all was over—only the fairies came no more!

OUR CAMPING-TRIP.

BY MABEL WINSLOW (AGE 13).

"The call of the wild" was too much for us,
In the city we could not remain;
So we bought a tent and some fishing-rods,
And boarded a north-bound train.

The road was rough, we were joggled a bit,
From the train to our camping-place;
But the horses were rugged, and we
were strong,
And accepted it with good grace.

We put up our tent, we made our beds,
And washed our faces and hands,
And cooked the luncheon of coffee and
eggs
In response to the urgent demands.

When night lowered down her somber
shades,
Ah! alack and alas for us!
The beds were lumpy and prickly and
hard,
And the "skeeters" made quite a fuss.

The weary, hot summer night was
passed,
With wailings of vain regret.
When I think of the gnats and the "skeeters" and flies,
I seem to feel them yet!

"T was too much for us—'To the city's heat!'"
Cried we at the end of the day;
"The forest's all right in the broad daylight,
But in the evening—oh! nay! nay! nay!"

THE FISH THAT GOT AWAY.

BY MARIE A. PIERSON (AGE 10).

IN the pond yonder, half shaded by the willow-trees, there was once a little fish who was amusing himself in the sun and trying to catch flies just for the pleasure of jumping in the sun. He was beginning to feel hungry, so he looked about him to see if there was anything to eat, and far away in the shade he saw a little red worm so lively, so appetizing, that he quickly swam to it and caught it. But oh, misfortune! the worm was only a bait on the end of a line. The poor little fish tried, but in vain, to get away from it. The horrible hook was doing its duty, and the poor little fish was

now going to be a prisoner. Then he thought of the good time he had had in the sun a few moments before and that he would perhaps never see again. Fortunately, the hand that held the line was not a very experienced one, as it was only a little boy's; and as he pulled the line up the fish gave such a jump that he fell in the water again, and oh, how much brighter the sun seemed to him, and what good times he had after such a fright! How careful he was never to touch a worm before he made sure that it was perfectly free! It had been such a narrow escape!

THE FISH THAT GOT AWAY.

BY LAURA E. BATES (AGE 14).

SOME years ago I spent a most delightful week camping with some of my young friends.

Our camp was situated in one of the most beautiful sites on the banks of the Buzi River, which flows through the Portuguese territory in Southeast Africa.

The scenery there was magnificent and the river was as clear as crystal. The gigantic trees about us, and the

OCTOBER

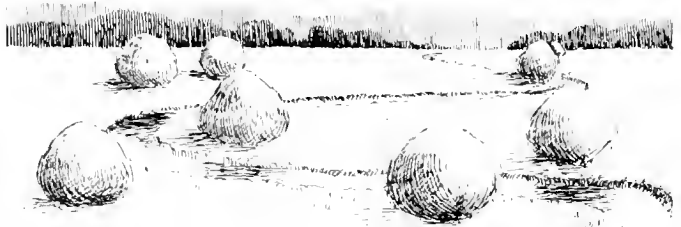

"A HEADING FOR OCTOBER" BY HELEN K. COLELAND, AGE 14. (SILVER BADGE.)

soft carpet of moss and leaves beneath, and the roar of the river near by, made an ideal place for a camp. Often at night we heard the roar of a lion from its lair among the rocks, but in all the time we remained there we never saw one, as they kept out of sight in the daytime.

The river abounded with fish of all sorts, and with crocodiles, too. We spent hours sitting on a tree over-

hanging the river, with our lines, and often caught enough for a good meal.

One very warm afternoon I called my maid and told her to bring her basket and line and come with me to fish.

We had fished for about an hour when suddenly I felt a hard pull on my line, and drew in a strange-looking fish, of a kind I had never seen before. It was black and had no scales. It resembled a catfish, but had no spines. I started to take it off the hook, but a sudden shock ran through my hands as I touched it, and it fell back into the water, where it escaped.

I was sorry to lose it; but what surprised and perplexed me most was what had made me drop it, and what had caused the shock when I touched it. I asked the girl, and she told me that it was an "electric fish," and that it sent this kind of a shock through whoever touched it. I tried very hard to catch another, but failed.

We left the camp for home soon after, and all decided that we had never had a finer time.

LEAGUE LETTERS.

OUR LEDGE, DUBLIN, N. H.

MY DEAR ST. NICHOLAS: I think maybe some of your readers would like to hear about a baby coryle I had for a pet last summer. My uncle brought her to me from Texas, where he bought her from the Ponca Indians. She was just like a puppy, and one of her favorite tricks was to take your ankle till you poked her up on your foot and threw her away; then she would immediately come back and begin over again. It was very funny to see her with a ball. If you rolled one at her, she would run at it; but as soon as she found it was not alive she would assume a look of profound disgust, and walk away in a very dignified manner.

Your interested reader,

MARGARET MCKITTRICK.

HARTFORD, Vt.

MY DEAR ST. NICHOLAS LEAGUE: In the June number of St. Nicholas I saw that suggestions would be welcome for the subjects, so I am sending you a list of subjects for the verse, prose, and photograph. I am trying very hard to get a prize, and hope to succeed sometime. I am going to compete every month now.

I collect postal cards, and have about two hundred and thirty. I exchange with Ruth and Gladys Manchester, of Winsted, Conn., and Josephine Whitbeck, of Berkeley, Cal.

I belong to Chapter No. 622, in Winsted, Conn., and, although I am not an active member, I attend the meetings by letter. That is, I say, the president and secretary and I write often to each other. Last month I went to see them, and had a lovely time. They are Ruth and Gladys Manchester.

I also correspond with Madeleine M. Dowell, of Boston.

I think St. Nicholas is a fine magazine, and the League is lovely. Helen Stearns, my friend, and I are very much interested in "Queen Zizi of Is." I also think that "Pikev Perkins" is very good. I like Margaret Johnson's things very much, too.

Fearing that this letter is getting too long, I will close.

From your devoted reader,

ALICE W. C. SULLIVAN.

MY DEAR ST. NICHOLAS: I like the majority of your readers. I am very much interested in "Queen Zizi of Is." but I think a story is much more interesting if you know something about the author.

So, having had the pleasure of meeting Mr. Baum in California last winter, I thought some of the readers might like to know a little about him.

Mr. Baum is a very distinguished-looking man, I think. He has dark hair and is very tall. He is pleasant and likes children, I in-

agine. He told me he wrote "Queen Zizi of Is." at his country home quite a while ago. It is the first story he has had serialized.

The Baums live in Chicago. There are four sons; one is an officer in the Philippines.

I think Mr. Baum was writing another story at Coronado.

Your interested reader,

CHARLOTTE COOK.

NEW YORK.

DEAR ST. NICHOLAS: I wish to state that Chapter No. 744 is a very great success. It started in November, 1903, with three members, including officers, president and secretary, and now we have twenty-one members. This may seem small to some, but consider that we do not have any in the chapter except those that will promote the welfare of the League. We have formed a battalion, and I send you our picture soon. We also have a baseball team and a track team; the latter has proven a great success. In the winter we have a hockey team, and we are all very fond of nature study. I would like it possible to have the names of chapters in the vicinity of Washington Heights, N. Y., and the names of the secretaries that I might write and get acquainted with them and have inter-chapter contests.

I remain, yours respectfully,

CHARLES ROTH.

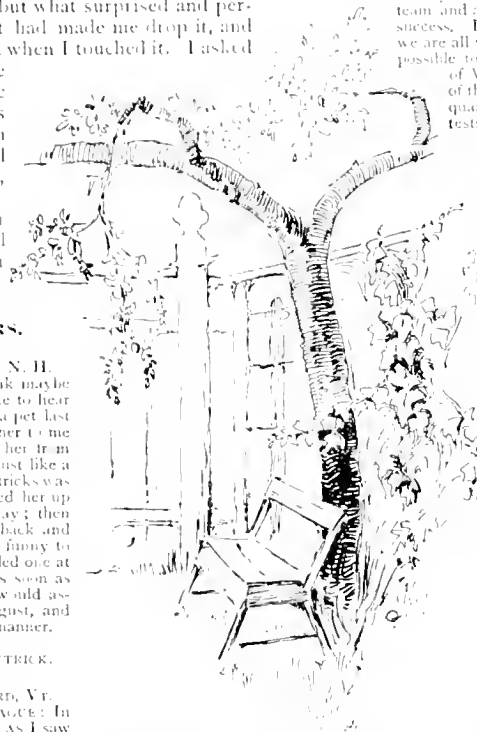

"A GUNL CORNELL," BY SETH HARRISON GURNEY, AGE 16. (SILVER BADGE.)

SHEPHERDS BUSH, FORTSON, PENNSYLVANIA.
DEAR ST. NICHOLAS: I feel I must write to you now. I am sending in my last contribution to the League, but in a few days I shall reach the age limit.

Oh, dear St. Nick, how can I thank you for the unlimited pleasure you have given me ever since I was old enough to be read aloud to? I think the most eloquent tribute I can pay is when I tell you I have a huge bookcase nearly full of I and volumes right away from your seventh birthday.

My brother when he was a small boy used to revel in you quite as much as I do now; and I think I may truly say, even though he is married, his fondness for dear old St. Nick has not degenerated in the least, and as for mine, well, it never will.

St. Nick, it makes one wish not to grow up if one is to be excluded from one of the greatest pleasures of childhood. But it will only be half gone, for I shall still continue to *revel* in you, and although I have grown too old to be a Leaguer, I shall watch the progress of those I have left behind.

It is not, however, without a trophy that I leave the League, and my silver badge is the dearest of my possessions. I had hoped to win a gold one, but at any rate I have one memento for my work.

I hope you will print this letter just to show how much an English child can appreciate and be sorry to leave an American magazine, and I am sure I echo the sentiments of thousands of your readers

when I say there is not another in the world that can compare with you.

Now, I suppose, if I write much more you will not be able to find room for it, so please accept the very sincere thanks from my brother and myself for the enjoyable hours you have given us.

With deepest regret, believe me, your devoted English Leaguer,

DOROTHY DE FOUL WILLIAMS.

Other appreciative and interesting letters have been received from Olive Day Thacher, Marguerite Zwick, Jonas Tidgen, Axel Worné Kates, Helen D. Long, Elizabeth Schub, Margaret Frances Andrews, Claire Curran, Emma D. Miller, Hilap W. Thayer, Frances C. J. Terry, Wald Scott, Dorothy Kerr Flood, John Bullock, Avela Louison, Myrtle Alderson, Elsie Stanton, F. Arch Bridges Hunt, John L. Taylor, Josephine Sturges, Helen North, De Haven, Helen C. Clark, Helen R. Sampson, Margaret A. Ludwig, Ruth A. Perkins, Walter M. Ellis.

SOUVENIR POSTALS.

The following members will exchange souvenir postal cards: John Orth, 142 E. 37th St., New York City; Manama Kriebler, 150 E. 71st St., New York City; Eleanor H. Bailey, Box 682, Mechanicsville, N. Y.; Helen Stroud, 117 Mackay St., Montreal, Can.; Elizabeth N. M. Kim, 9 Towers Ave., Montreal, Can.; William S. Rusk, 200 E. Baltimore St., Baltimore, Md.; Alice Harmon Peavey, 51 May St., Worcester, Mass.; Grace L. Hummes, Cedarville, N. J. (foreign cards); Margaret McKittrick, Oak Ledge, Dublin, N. H.



"OCTOBER." BY SHIRLEY CLEMENT, AGE 10

THE ROLL OF HONOR.

No. 1. A list of those whose work would have been used had space permitted

No. 2. A list of those whose work entitles them to encouragement.

VERSE 1.

Clement R. Wood
Donald Benson Bland-
ing
Alice Shirley Willis
Katharine Hitt
Beulah H. Ridgeway
Abby Dunning
Kathryn Sprague De
Wolf
Margaret Stuart
Browne
Dorothy P. Wetherald
Nannie Clark Barr
Emmeline Bradshaw
Louise Wells
Helen M. Barton
Marie Armstrong
Constance Votey
Claire Lawall
Sybil Kent Stone

VERSE 2.

Dorothy Elizabeth
Hildreth
Isabell Strathy
Doris Weel
Glady's M. Adams
Mary Elizabeth Mair
Helen Chandler Willis
Helen Leslie Follans-
bee
Twila A. McDowell
Margaret E. Riekey
Olive L. Jenkins
Ella T. Howard
Glady's M. Crockett
Louisa F. Spear
Marjorie C. Paddock
Maude H. Brisse
Mildred Seitz
Louisa McLeod
Mitchell
Edith Evans Young
Margaret Wing Ste-
vens
Alma O. Jones
Dorothea Bachtel
Rachel Thayer
Anna Evelyn Holman
Helen Copeland
Coombs
Alice Seabury
Matthewson
Mary Baxter Ellis
Cora Edith Wellman
Charlotte B. Williams
Corinne Benoit
Elinor L. P. Lyon
Leslie Ross
Langdon Morris
Dorothy Buell
Noel Johnston
Marie O. Keller
Ruth F. Rowe
Doris F. Holman
Glady's Müller
Ruth Bronler

PROSE 1.

Beatrice Treadway
Elizabeth Toof

Lucey H. Catlett
Dorothy Elizabeth
Willy
Gracie Canner
Mallory Webster
H. K. Pease
Mary E. Gunnell
Mary Raridan Gray
Walter E. Isaacs
Dorothy Jones
Alice Weston Cone
Caroline C. Johnson
Carrie F. Gordon
Dorothy Pipeckney
Irene F. Wetmore
Elsie F. Weil
Haudassah Backus
Lillian Van Wart
Mildred Lissner
Clara R. Williamson
Helen Coatsworth
Margaret Evelyn
Nordhoff
Frances Jeffery
Ruth E. Wilson
Elizabeth J. Phillips
Cordelia Jennais
Herbert Dean
Grace Harney
Elizabeth Hiss
Alice Bentley Gantt
Rose Hirsch
Esther S. Conger
Elizabeth Fine Strong

PROSE 2.

Elizabeth Osgood
Collier
Glady's E. Weaver
Marguerite Stevenson
Charles Atkins
Glady's Alison
Stephen Wood
Edna Tompkins
Allen J. Brewer
Monica Shannon
Gertrude Burwell
Marjorie F. Stewart
Willamette Partridge
Bessie Stella Jones
Alma Wiesner
Julia G. Moore
Ruth McNamee
Elizabeth R. Marvin
George Switzer
Sara C. James
Gertrude Palmer
Bertha Torchiani
Lois F. Lovejoy
Dorothy Cooke
Theodora B. Eliot
McComick
Henry B. Dillard
Harriette E. Cushman
Joyce M. Shocim
Glady's L. Carroll
Louise M. Wiley
Midge Elderkin
Bertha Hansen
Rosamond J. Walker
Edith Adams
Margaret P. Talbot

Josie Hampton
Elizabeth K. Hirsch
Irene S. Beir
Elizabeth Allen
Beatrice Kelley
Norah Hume Blake
Dorothy Hastings
Elsie Alexander
Esther Patterson
Watkins
Mary V. Lee
Vincent M. Ward
Janet Ruth Rankin
Dorothy Evers
Margaret Dow
James E. Moran
Luella Rice
Virginia Coyne
Charles E. Mc-
Clumpha
J. Macpherson
Nelly Paton Walsh
Gertrude A. Hickok
Isabella McGhee
Tyson
Alice May Stevenson
Carolyn McNutt
George B. Patterson
Mildred Tade
Dorothy Dayton
Katharine Dietz
James Symington
Beulah G. Knox
Marjorie P. Greenfield
Elizabeth Ben Brice
Howard R. Patch
Glady's Atwell
Victor Moffet
Doris Eldridge Hodg-
son
Willie Dow
Therese Born
Ruth M. Stevens
Elsa Schneider

DRAWINGS 1.

Natalie Johnson
Charlotte Waugh
Stanislaus F. McNeill
Hilda Rowena Bronson
Mark F. Boyd
Enid E. Jones
Olive Mudie-Cooke
Melville C. Levey
Cordner H. Smith
Hester Margetson
Ruth Cutler
Mary B. Thomas
Marjorie T. Caldwell
Anne Furman Gold-
smith
William M. Robson
Mildred Andrus
Sophie Langdon Mott
Edwina Spear
Anne Latane Clopton
Guadalupe Alvarez
Cortina

DRAWINGS 2.

Harriette Jarney Urt
Carl B. Timberlake
Ruth May

Margaret Dobson
Minnie M. Ferry
Addison F. Worthing-
ton
Louise Kildreth
Credin
Rena Kellner
Helen L. Slack
Glady's L'E. Moore
Helen H. Stafford
Maude G. Barton
Anita Firestone
Helen Reading
Josephine Holloway
Martha B. Taylor
Robert Schulkers
Esther A. Tiffany
Rita Ward
Elizabeth MacDougall
Dorothy F. Eaton
Joseph Hayes Birch-
field
Grace F. Slack
Margaret Reed
Winifred C. Hamilton
Lucia Halstead
Paul Bathurst V. Ulen
Sidney J. Cohen
Margaret B. Richard-
son
Gena M. Goode
Mary Smith
Mary Aurilla Jones
Alice Humphrey

Esther S. Root
Dorothy Bruce
Peggy Bacon
Fannie Bean
Wilfrid Swancourt
Bronson
Sarah Perkins Madill
Mary Klauder
Valentine Willoughby
Charlotte H. Knapp
Richard T. Cox
Elizabeth Park
Marjorie Schnarr
George W. Hall
Morgan O. Bagart
K. T. Young
Seibert Fairman
Elizabeth Knowlton
Sylvia Sherman
Lansing C. Holden, Jr.
Beatrice Adams
Joseph Stenbuck

PHOTOGRAPHS 1.

Helen Bennett Brooks
Judith D. Barker
Mabel C. Becker
Robert Edward
Fithian
Lucie E. Halstead
Jennie F. Shaw
Madeleine Appleton
Richard Elterich

Edna Browning
Elsie Bishop Bucking-
ham
Isabel M. Rex
E. Bunting Moore
Marion V. S. Toedt
Francis M. Weston, Jr.
Charlotte Cook
Laurence A. Morey
Elizabeth K. Stokes
Ray McCallum
Ruth E. Rheim
Allyn R. Fraser
Albert Torbet, Jr.
J. M. Shaw
Henry Thorpe
Moss Guibert
Dagmar von Visting-
hoff
Bettine Paddock
Elizabeth S. Brusie
Cecilia Brewster
Dorothy Wormser
Dorothy Carson
Janet H. Freeman
Philoma Becker
Dorothy L. Nichols
Rosemary Baker
Helen Mar Sea
Margaret Sharpe
Edith Cranch
Eleanor B. Southworth
D'Arey Orde
Marion Decker

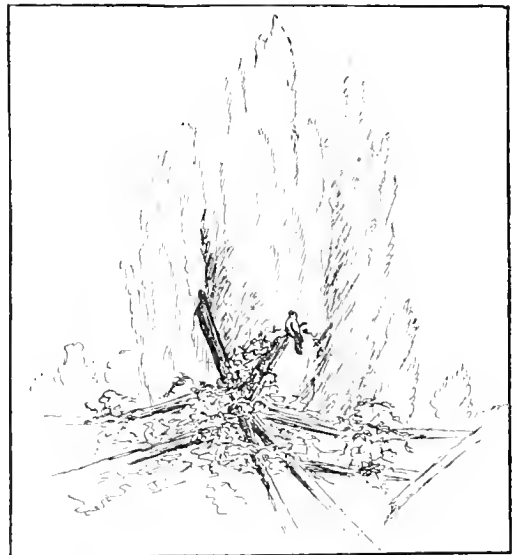

"A FENCE CORNER." BY IRENE K. MOREY, AGE 12.

Dorothy Haug
Harry B. Morse
Ruth Maurer
Russell Alger Deily
Walter Pettit
Arthur Nehf
Constance Bowles
Dorothy Bliss Usher
Harriet L. Eager
Margaret Osborne
Stuart B. Taylor
Anna Paddock
Leicester Spaulding
Charlie Higgins
Dorothy Eaton
Katharine Dukebella
Barbour
Nelly B. Lewis
Edna Mason Chapman

W. Ann Cox
Geratidine Doyle
Vera Van Nes
Anna S. Ward
Stuart M. Young
Alice H. Miller
Mabel W. Whiteley
Anna D. White
Nadine Bolles
Marguerite Strathy
Mary C. Smith
S. B. Murray, Jr.

PHOTOGRAPHS 2.

John Struthers
Anna R. Clark
Alice Moore
Launcelot J. Gamble
Dorothy Arnold

Katherine Decker
Mary Thompson
Florence Bayard Trail
Mary R. Paul
Marian C. Rowe
Dorothy Houghton
Natalie Ott
Donald C. Armour
Penelope Barker
Noyes
R. Ernest Bell
Helen L. K. Porter
Helen Lyon Merriam
Elizabeth Cameron
Henry H. Ballou
Marrrianna Lippincott
Robert C. Seamans
Helen Whitman
Glady's E. Chamberlain
Orlan E. Dyer

Katharine E. Pratt
Jess I. Hall
Margaret A. Doyle
Marjorie E. Clare
Catharine E. Jackson
G. R. Whitehead
Helen R. Crouch
Ruth H. Caldwell
Elizabeth H. Webster
Alice L. Cousins
Nellie Shane
Eleanor Marvin
Louise Fitz
Emily Vocum Brown-
back
Henry N. Olen
Frances S. Loney
Edith A. Hoff
Eleanor B. Danforth
Charles M. Ffoolke,
Jr.
Lawrence V. Sheridan
Myrtle Alderson

Gwendolen Gray Perry
Seward C. Simons
Rose C. Huff
Elsa van Ness
Florence Short
Julie H. Shepley
Bernard Rejbein

PUZZLES 4

Gwenna M. Jones
Alice D. Korr
Catharine H. Straker
Agnes R. Lane
Harry W. Hazard
A. Zane Pyles
Emma D. Miller
Doris Hackbusch
E. Adelaide Hahn
Walker M. Ellis
Milton F. Lyon
Mary Angwood
L. Elsa Foerber

Edwin Holmes Adri-
ance
Elmer Margaret Hunter
Prue K. James n

PUZZLES 2.

John E. Staebelin
Anne M. Kross
Anne H. Whiting
Florence A. Brooks
Edwin S. Horwitz
Dorothy Godfrey
Elizabeth Beal Berry
Rose M. Morton
Helen Dean Fish
Blanche Bloch
Gladys Richardson
Margaret R. Bonnell
Nma Williams
Dorothea S. Walker
Marianna Kroehle
Sarah Anna

President, Charles Atkins, Secretary; eleven members. Address, 1127 E. 45th St., L. S. Angeles, Cal.
No. 241. "Beverly Theatricals." Eleanor C. Bancroft, Presi-
dent, four members. Address, Hale Farm, Beverly, Mass.
No. 242. "Ambitious Chapter." Elizabeth R. Marvin, Presi-
dent; Anne I. Clopton, Secretary; thirteen members. Address,
Canaan, Va.

NOTICE.

SUGGESTIONS for League features and subjects for competition
are always welcome.

PRIZE COMPETITION No. 73.

THE St. Nicholas League awards gold and silver
badges each month for the best *original* poems, stories,
drawings, photographs, puzzles, and puzzle-answers.
Also cash prizes of five dollars each to gold-badge
winners who shall again win first place. This does not
include "Wild Animal and Bird Photograph" prize-
winners.

Competition No. 73 will close **October 20** (for foreign
members **October 25**). The awards will be announced
and prize contributions published in **ST. NICHOLAS**
for **January**.

Verse. To contain not more than twenty-four lines.
Title: "The Frozen Brook."

Prose. Story or article of not more than four hun-
dred words. Subject, "A Family Tradition"—must
be genuine, not invented.

Photograph. Any size, interior or exterior, mounted
or unmounted; no blue prints or negatives. Subject,
"The View from my Home."

Drawing. India ink, very black writing-ink, or wash
(not color). Two subjects, "A Landscape Memory"
and a Heading or Tailpiece for January.

Puzzle. Any sort, but must be accompanied by the
answer in full, and must be indorsed.

Puzzle-answers. Best, neatest, and most complete
set of answers to puzzles in this issue of **ST. NICHOLAS**.
Must be indorsed.

Wild Animal or Bird Photograph. To encourage
the pursuing of game with a camera instead of a gun.
For the best photograph of a wild animal or bird taken
in its natural home: *First Prize*, five dollars and League
gold badge. *Second Prize*, three dollars and League
gold badge. *Third Prize*, League gold badge.

RULES.

ANY reader of **ST. NICHOLAS**, whether a subscriber
or not, is entitled to League membership, and a League
badge and leaflet, which will be sent free.

Every contribution, of whatever kind, *must* bear the
name, age, and address of the sender, and be indorsed as "*original*" by
parent, teacher, or guardian, *who must be convinced beyond doubt that
the contribution is not copied*, but
wholly the work and idea of the
sender. If prose, the number of
words should also be added. These
things must not be on a separate sheet,
but on the contribution itself—if a
manuscript, on the upper margin; if
a picture, on the margin or back.
Write or draw on *one side of the paper
only*. A contributor may send but
one contribution a month—not one
of each kind, but one only. Address:

The St. Nicholas League,
Union Square,
New York.

LEAGUE NOTES.

ONCE more we are obliged to record the sad fact that one of our
League contributors has been so unfair, or so disregardful of the
rules, as to send a poem deliberately copied—this time from one of
Longfellow's translations. "The Wave," by Kathryn Lewis, page
646 of the August League, is almost an exact copy of a poem of the
same name by the German poet Tiedge, as translated by Long-
fellow. The League editor was not familiar with this poem,—he
cannot be familiar with all the poetry ever written, even by the
masters,—but instantly upon its publication it was reported by a
League reader who remembered it, and then by members from all
directions. It is easy, very easy, to deceive any one or two people;
but it is absolutely impossible for any borrowed contribution to
escape the thousands upon thousands of League readers, who guard
the League with the fond interest of personal ownership, and are
quick to report any breach of honor among its members. Of course
the gold badge awarded for "The Wave" was not sent, and the
offending member's name was dropped. Whether the offense was
committed through ignorance or intent does not matter. The
League rules are plainly printed in every issue, and ignorance of
them is no excuse. Does it pay to risk one's good name for the sake
of any prize the world can give?

CHAPTERS.

If all League members knew how much fun chapters have, and
how much they are benefited by their meeting, every member
would be a chapter member. Chapters meet and read the League
contributions and other interesting things aloud, play games, get up
entertainments, and work together in many ways. Some of them
have small dues and sets of rules and regular meeting-places.
Others meet at members' houses in rotation, and enjoy themselves
in any way that pleases them for the time. To read and discuss the
League contributions is one of the most profitable features. New
chapters forming may have their badges, etc., come in one large
envelope, postage free.

NEW CHAPTERS.

No. 832. "Fairy Glen Club." Arthur Gupta, President; W.
Barlow Hill, Secretary; eight members. Address, Gorham, Me.
No. 833. "S. N. L." Roy Whitford, Sec-
retary; six members. Address, 903 Jefferson
St., Wilmington, Del.
No. 834. "Theta Sigma Sigma" Carol
Sterling, President; Cornelia S. Penfield, Sec-
retary; six members. Address, Beacon St.,
Black Rock, Conn.
No. 835. "St. Nicholas Jolly Club." Emily
Paane, President; Helen Pichard, Sec-
retary; five members. Address, 121 Washing-
ton Lane, Germantown, Pa.
No. 836. "Ye Merne Sixe." Dorothy
Campbell, President; Elizabeth Hirsch, Sec-
retary; six members. Address, 922 S. 48th
St., Phila. Pa.
No. 837. "Conococheague" Anna C.
Buchanan, President; six members. Ad-
dress, Chambersburg, Pa.
No. 838. Ruth Hughes, President; Alice
Lowenuth, Secretary; four members. Ad-
dress, 142 Spencer St., Rochester, N. Y.
No. 839. "Aqua Pura." John Taylor, Sec-
retary; five members. Address, Arlington
Heights, Ill.
No. 840. "Golden Star." Ariel C. Harris,



"A FENCE CORNER." BY DOROTHEA
KEASBY, AGE 13.

BOOKS AND READING.

THE NAME "OCTOBER." EVEN the younger Latin students know why October is named the eighth month; but not all of you are aware that there have been five attempts to change the name to honor Roman sovereigns. The Saxons called the month "Wintersfylleth," and chose hawking as its emblematic sport.

"CANDY" BOOKS. A DAILY paper quotes from the President of Clark University, Massachusetts, the statement that "moral improvement should be the supreme standard in judging the reading for the young," and wisely says: "At least half of true morality consists in a perception of the vein of sunniness which animates all things, and that this aspect of life and nature is best blended into the spirits of growing children by books," such as "Alice in Wonderland"—which the college professor seems to have declared "confectionery, and not mental food."

But confectionery is the best of good food, if taken in right amount and at the right seasons. No one believes in spoiling the appetite by a diet of sugar only, any more than in keeping sugar entirely out of the diet. Even the soldier needs sugar in his scientific ration; and young people need a reasonable amount of confectionery in reading.

LATER NEWS DESIRED. IN going over the letters received in this department, one cannot help wondering who reads all the new books for young people. Although many long lists are sent, only rarely is one of the newer books mentioned. Will not some bright girl or sagacious boy tell us of the newer books that she or he has read and found delightful?

CROMWELL'S ADVICE. IN an essay showing how much nations owed to books as helpers, Sidney Lee, the English scholar, quotes Oliver Cromwell's advice to his son Richard: "Do not scatter yourself over a great many short and comparatively trifling books," said the great Protector; "devote yourself to a long book, a book that takes a wide survey of human affairs, a book that is

written in a great style." Cromwell recommended Raleigh's "History of the World," but what book better fits his advice than the Bible? The girl or boy who does not become familiar with the Bible is never truly educated.

BOOK "RELATIVES" AND BOOK "FRIENDS." YOUR own little library should consist of two classes of books—one class, of those that are your relatives; the other, of those that are your friends or mere acquaintances. The "relatives" are the books you mean to live with all your lives; the "friends" or acquaintances are those to whom you are kindly hosts for only a while.

LEIGH HUNT'S CHOICE OF BOOKS. IT is often asked what book would be chosen if but one were allowed from all one's library. Leigh Hunt answers this question in a poem that is little known. It is quoted in Brander Matthews's "Ballads of Books," a little volume full of charming and unusual verse. Leigh Hunt says:

But which take with me, could I take but one?
Shakspeare, as long as I was unoppressed
With the world's weight, making sad thoughts tenser;
But did I wish, out of the common sun,
To lay a wounded heart in leafy rest,
And dream of things far off and healing—Spenser.

Few young readers desire "to lay a wounded heart in leafy rest," we hope; but all boys and girls who love good fairy-stories ought to know what delightful old-time tales are to be found in the works of Edmund Spenser.

HISTORICAL STORIES. MANY of the more recent books for the reading of young people are meant to give a knowledge of certain periods of history. Very often these are carefully studied by their authors; but, nevertheless, they seldom give a true idea of the real events. At times, a little skirmish will be made to seem a great battle, so that the doings of some boy-hero may be made more important; at other times, the stories are written to please the prejudices of some readers—one army being composed entirely of noble, self-

sacrificing patriots, while their enemies are all sneaking villains.

If you read such books, it is very wise to prepare yourself by a little study of the same period in a fairly written history. Besides, you may find the history better reading than the juvenile book.

This warning applies especially to stories of the American revolutionary days.

STORY-TELLING POEMS. OUR request for "poems that tell stories" brings only lists of the old, old favorites, such as "Hiawatha," "Evangeline," "Idylls of the King," "The Ancient Mariner," and "The Vision of Sir Launfal." We should like the names of some a little less known. There are many excellent collections of verse for young readers. Perhaps some of our readers will find this list useful:

"The Children's Garland," "The Children's Treasury," and "The Sunday Book of Poetry," all in the Golden Treasury Series published by Macmillan & Co.; "Poems of American Patriotism," Scribner's; "Book of Famous Verse," Houghton, Mifflin & Co.; "The Listening Child," Macmillan & Co.; "Poems Every Child Should Know," Doubleday, Page & Co.; "The Posy Ring," Houghton, Mifflin & Co.; "Lyra Heroica," Scribner's; and "Blue Poetry Book," Macmillan & Co.

All these are well edited and contain the best of material carefully chosen. Every child should own at least one of them.

WHAT HE HAS READ. A VERMONT boy sends us a list of books he read not long ago. It seems to be very well selected in quality and in variety. He does not tell his age, but we guess him to be about thirteen. We give all he names: "King Mombo," Du Chaillu; "Under Colonial Colors," Tomlinson; "A Captured Santa Claus," Page; "Ivanhoe," Scott; "Chasing the Sun," Ballantyne; "Rollo in Rome," Abbott; "Just So Stories," Kipling; "Poor and Proud," "The Boat Club," "Try Again," and "All Aboard," by "Oliver Optic"; "Donald and Dorothy," Mrs. Dodge; "Jan of the Windmill," Mrs. Ewing.

WHAT IS A "CURMUDGEON"? DR. JOHN ASH wrote a dictionary of the English language in 1775, and must have used Dr. Johnson's dictionary to aid him in tracing cer-

tain derivations. Johnson, in giving the origin of the word "curmudgeon," said that it came from the French words "*cœur*" and "*mech int*" (heart, wicked), and credited the suggestion to an "unknown correspondent." Dr. Ash copied the derivation, but unfortunately made a strange blunder, saying that "curmudgeon" was "from the French *cœur*, unknown, and *mechant*, a correspondent"!

Who, without the explanation, could have guessed the origin of this funny blunder? And who, among our older readers will show the connection between a "curmudgeon" and the queer old phrase used by Hamlet, "This is *niching mallecho*; it means mischief"?

One learns to value dictionaries more highly after learning how many long years and how much labor have been spent in their making.

"CONVALESCENT" BOOKS. FROM Philadelphia we receive a letter giving an excellent list of books to read aloud to a little invalid during the days when recovery is certain and yet the hours of waiting are so long. The books named are recommended as cheerful in tone, and interesting for reading to one not to be excited. Here is the list:

"The Adventures of Ulysses," Kingsley; "La Belle Nivernaise," Daudet; "The Last American," Mitchell; "Cranford," Gaskell; "Peterkin Papers," Hale; "The Rose and the Ring," Thackeray; "The Bucholz Family," Stinde; "Pickwick Papers," Dickens; "Book of Romance," Lang; "Myths of Greece and Rome," Guerber; "Travels of Marco Polo," Brooks; "True Story Book," Lang; "Parables from Nature," Gatty; "Fairland of Science," Buckley.

MAKING HISTORY COME TO LIFE. Do you know who was "The Wizard of the North"? He was so called because he was able to bring to life the personages of past time, making history live again in his pages, so that the happenings of old time seem once more to take place before our eyes, and knights, ladies, kings, queens, esquires, soldiers, outlaws, played their parts upon the stage he created within the minds of his readers. Nearly eight centuries are covered by the works of his genius in his prose alone, and in his verse his range was even wider. How much do you know of the realm of this magician and what was his name?

EDITORIAL NOTE.

THE lamentable death of Mrs. Dodge occurred just as this October number of ST. NICHOLAS was going to press. It is necessary, therefore, to ask the indulgence of our readers if their copies this month should be late in reaching them, as the presses had to be stopped for the preparation of the all too brief and inadequate memorial sketch of Mrs. Dodge which opens this number. ST. NICHOLAS, like all monthly magazines, has to be made ready far in advance of the date of publication; and the September number was off the press and on its way to the news-stands when the sad tidings of Mrs. Dodge's death were received.

THE LETTER-BOX.

PARIS, FRANCE.

DEAR ST. NICHOLAS: I am a little American girl and in May we went abroad.

We are now in Paris and I saw King Alfonso XIII of Spain. The city was beautifully decorated with flags and electric lights, in the shape of crowns, coats of arms, and stars, and large baskets of flowers of all kinds on the street.

The day we saw him an attempt was made on his life. A bomb was thrown from Hotel du Louvre, but it did not injure him; it killed a horse and wounded some of the soldiers. I have been taking you for three years and like you very much. Good-by,

From your little reader,
DOROTHY SELIGMAN (age 9).

QUINCY, ILL.

DEAR ST. NICHOLAS: I don't think many Americans (or people in America) living to-day have had the honor of knowing Richard Wagner, the composer of the great "Parsifal."

Well, I have found a person who has had that honor, and so I thought perhaps some of the other readers of ST. NICHOLAS would like to hear about it.

I went to hear "Parsifal," in Chicago last month, and when I got home, one Saturday, I spent a day in the country. There I met an old German woman, and, incidentally, I mentioned "Parsifal."

"Oh," she said, and her face lighted up; "when I was a girl I lived in Baireuth and carried milk every evening to Wagner's house. I knew the family and saw him often. I liked to watch the workmen nearby, building the great stage where he was going to have his first production of 'Parsifal.'"

I thought this interesting.

I am, A devoted reader,
ETHEL C. IRWIN (age 14).

MUNICH, BAVARIA.

DEAR ST. NICHOLAS: We have been interested in the attention paid here to the hardy little birds that stay north all winter.

As soon as the cold weather set in, there appeared in the city squares and public-school yards what, from a distance, looked like huge green mushrooms.

Upon a nearer view, we saw them to be shelters for birds.

A post, or a branch still wearing its bark, had been driven into the ground. Upon it was fastened a little wooden platform about two feet in diameter; then, above the platform and almost hiding it, a dome of evergreen twigs.

The birds can slip in through openings left among

the twigs at the edge of the platform, and there, sheltered from snow and wind, eat the seeds scattered for them on the boards.

If they ever *were* suspicious of such queer trees in such frequented places, they have learned better. The tables so bountifully spread with seeds do not now lack visitors.

I remain, as I have been for eight years,
Your interested reader,
ALICE S. CHEYNEY.

MOUNT PLEASANT, ST. JOHN, N. B., CANADA.

DEAR ST. NICHOLAS: I am a Canadian boy and enjoy you very much; my brother took you for some time and I am interested in the League.

Out in our yard I have a small house which we have called the "Bachelor's Den," and in which we have often slept.

A little while ago the first turbine steamer to cross the Atlantic landed in St. John.

Yours truly,
W. WALLACE ALWARD (age 12).

SAN DIEGO, CAL.

DEAR ST. NICHOLAS: I have taken you for a year and a half and I read everything in you from cover to cover.

We are living at La Jolla, a little California coast-town, where many noted people spend the winter.

We live next door to Rose Hartwick Thorpe, the author of "The Curfew Shall Not Ring To-night."

Mrs. Thorpe wrote for ST. NICHOLAS when mother was one of your little readers.

There are a great many natural beauties here at La Jolla, among them are some wonderful caves on the ocean front. The water washing upon the rocks and walls of the caves have formed strange designs; some of them are so perfect in their outlines as to suggest the work of man.

Your faithful reader,
ROBERT BOSTWICK CARNEY (age 10).

CLEVELAND, OHIO.

DEAR ST. NICHOLAS: I am writing you this letter to let you know how I love your magazine. I have read "Pinkey Perkins," and thought it was very nice, and "The Magic Cloak." We had to learn a poem in school about "Abou Ben Adhem."

We are very interested with the flowers that just came out. Snowballs all are very large in our yard; the violets are so pretty.

From a loving member of your magazine.
RACHEL GELTMAN.



ANSWERS TO PUZZLES IN THE SEPTEMBER NUMBER.

WORD-SQUARE: 1. Ruble. 2. Union. 3. Bigot. 4. Loose. 5. Enter.

DOUBLE ACROSTIC. Initials, Shakespeare; fifth row, As You Like It. Cross-words: 1. Syrian. 2. Harass. 3. Alleys. 4. Knowtow. 5. Efflux. 6. Spoils. 7. Picnic. 8. Eureka. 9. Answer to Rebat. 11. Elects.

CHARADE. Goal-den-rod, goldenrod.

DOUBLE ZIGZAG. From 1 to 8, Tennyson; 9 to 16, Trollope. Cross-words: 1. Twit. 2. Herb. 3. Pony. 4. Loon. 5. Lazy. 6. Host. 7. Hope. 8. Name.

ILLUSTRATED NUMERICAL ENIGMA.

The bees warp lazily on laden wing;
Beauty and stillness brood o'er everything.

TO OUR PUZZLERS: Answers, to be acknowledged in the magazine, must be received not later than the 15th of each month, and should be addressed to ST. NICHOLAS Riddle-box, care of THE CENTURY CO., 33 East Seventeenth St., New York City.

ANSWERS TO ALL THE PUZZLES IN THE JULY NUMBER were received, before July 15th, from "Duluth"—K. W. and F. McCollin—Mary B. Bloss—Marian Swift—Zena Parker—Frank L. White—Harry Elger, Jr.—Grace Haren—Marian Smith—Florence DuBois—Lucile Fricc—Caroline Ray Servin—"Two Puzzlers"—Constance Codman—Margaret Griffith—May Richardson—Louis Stix Weiss—Harriet Bingham—Wimfred A. Anderson—Marion Patton—Florence Ross Elwell—"Allid and Adi"—No Name, Chicago—"Chuck"—Harriet O'Donnell—Tanetta E. Vanderpool—Elizabeth D. Lord—Albert Ellard—Dorothy Rutherford—Joseph Bolton—Mary E. Miller—Robert S. DuBois—Dorothy E. Hopkins—Lilian Sara Burt—Agnes Cole—Lettia Vicle—Marguerite Hyde.

ANSWERS TO PUZZLES IN THE JULY NUMBER were received, before July 15th, from J. R. Maclaren, 1—E. C. Banroft, 1—A. Mayo, 1—V. Moffet, 2—S. C. Titus, 1—James P. Cahen, Jr., 3—Marion McS., 1—Adele Beatty, 3—G. Weibrecht, 1—Edna Meyle, 5—Katharine B. Hodgkins, 5—Mary G. Bonner, 2—O. Elizabeth Dyer, 6—C. Hanks, 1—Elsie Nathan, 3—F. Anthony, 3—Mary E. Askew, 6—Rodia Rolfe, 6—C. J. Gladding, 1—M. C. Sawyer, 1—F. R. Hodges, 1—Janet Willoughby, 3—K. Trowbridge, 1—B. W. Smith, 1.

A MINE OF "OR."

(Silver Badge, St. Nicholas League Competition.)

EXAMPLES: A valued "or," hon-or. A reptile or, alligat-or.

1. A witty or. 2. A zealous or. 3. A fearful or. 4. A conquering or. 5. An outspoken or. 6. A noisy or. 7. A younger or. 8. A leafy or. 9. A working or. 10. A South American ornithological or. 11. An energetic or. 12. A gracious or. 13. A will-making or. 14. A strict or. 15. An imprisoned or. 16. An older or.

RICHARD G. CURTIS.

ENIGMA.

4

CHANGE this figure to another system of notation and it will give the name of a rare old plant.

W. B. GIBSON (AGE 7) (League Member).

ZIGZAG.

(Silver Badge, St. Nicholas League Competition.)

EACH of the words described contains eight letters. When these are rightly guessed and written one below another, the zigzag (beginning with the upper left-hand

CONNECTED WORD-SQUARES. I. 1. Brave. 2. Raven. 3. Avert. 4. Verse. 5. Luter. II. 1. Rang. 2. Area. 3. Near. 4. Garb. III. 1. Clear. 2. Leave. 3. Faves. 4. Avert. 5. Rests. IV. 1. Star. 2. Tart. 3. Area. 4. Read. V. 1. Oscar. 2. Scare. 3. Care. 4. Arena. 5. Redan. VI. 1. Scar. 2. Care. 3. Area. 4. Read. VII. 1. Mason. 2. Adore. 3. Souls. 4. Orlet. 5. Nests. VIII. 1. Drag. 2. Raive. 3. Avert. 4. Germ. IX. 1. Bar. 2. Are. 3. Red.

GEOMETRICAL PUZZLE. 1, o; 2, u; 3, a; 4, t; 5, d; 6, b; 7, i; 8, g; 9, b; o, n.

DOUBLE BEHEADINGS AND CURTAILINGS. Cotton Mather, 1. In-oc-on, cot. 2. Al-low-ed, owl. 3. St-unt-ed, tun. 4. Bu-ning, tin. 5. Se-old-ed, old. 6. Se-ent-ed, net. 7. Co-mpa-ny, map. 8. In-dia-ns, and. 9. H-n-tes, ten. 10. Sw-a-th-es, hat. 11. Co-ll-e-ge, ell. 12. Shar-er, rap.

letter and ending with the lower left-hand letter) will spell the title and surname of a President of the United States.

1. A chemist's measuring-glass. 2. To adorn. 3. Steadfast. 4. Headless. 5. Hanging fluttering in the air. 6. A banner. 7. Abruptly. 8. Force. 9. Pertaining to a nation. 10. A three-headed monster. 11. Concealing. 12. A remedy. 13. One of the United States. 14. Melancholy. 15. One of the United States.

HERBERT M. DAVIDSON (AGE 9).

HOOR-GLASS.

.....
.....
.....
.....
.....
.....
.....
.....

READING ACROSS: 1. A man of learning. 2. To happen. 3. A pronoun. 4. In hour-glass. 5. To recede. 6. An animal. 7. Erudite.

Centrals, reading downward, a month.

ELIZABETH BURKAGE (League Member).

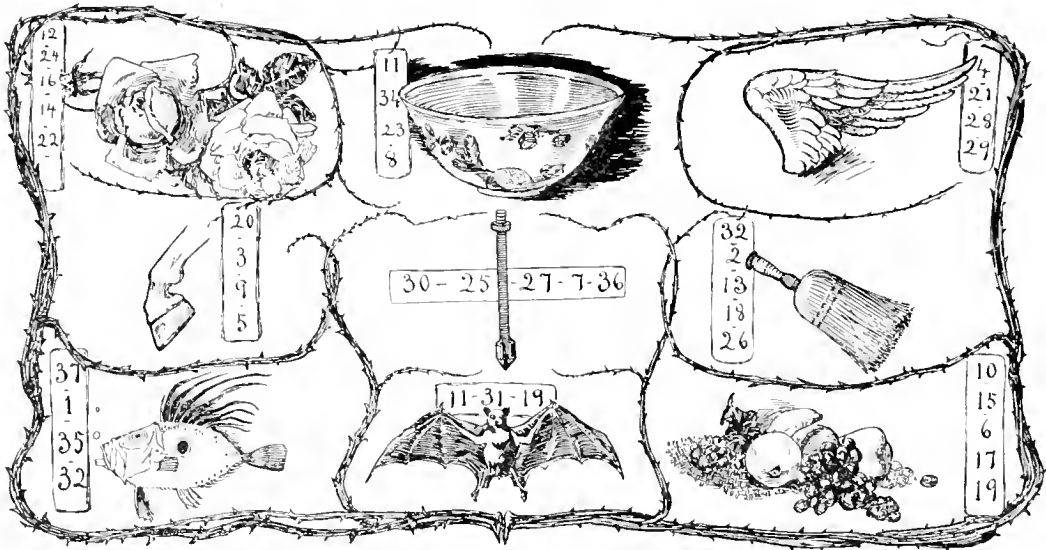

ILLUSTRATED NUMERICAL ENIGMA.

In this numerical enigma the words are pictured instead of described. When the nine objects have been rightly guessed, and the letters set down in proper order, they will spell a quotation from "As You Like It."

A GREEK ACROSTIC.

(Gold Badge, St. Nicholas League Competition.)

WHEN the following words have been rightly guessed and written one below another, one of the rows of letters, reading downward, will spell the name of the "Father of History."

CROSS-WORDS (of unequal length): 1. A famous Greek philosopher and mathematician. 2. The greatest of Greek poets. 3. A very famous Greek philosopher. 4. a famous disciple of the foregoing. 5. The greatest of the Greek lyric poets. 6. The greatest of Greek orators. 7. A famous Greek philosopher of noble birth. 8. The name of some cities called after the Emperor Claudius. 9. The most influential of Greek philosophers.

FLORENCE CASSIDY.

CHARADE.

My *first* is a word that much magic has wrought;
My *last* is a vessel no sailor has sought;
My *whole* is used for support, I am told,
By photographers, over the new world and old.

HILEN A. SIBLEY.

REVERSED RIVERS.

(Gold Badge, St. Nicholas League Competition.)

In each of the following sentences is concealed the name of a river, the letters forming it being reversed.

1. I found a robin's nest hidden among the catalpa leaves.
2. Those who are bitten by rattlesnakes seldom recover.
3. Skibo Castle is the home of a great manufacturer.
4. Fred offered to go for a doctor.
5. The panels of the ceiling were of black walnut.
6. Real estate values in this town have trebled during the past year.
7. When I was in Cairo I hoped to visit the Pyramids.
8. Wilkins and Sons sell crêpe in desired quantities at low prices.
9. The opal is a beautiful gem.
10. Those who honor the flag love their country.

11. My brother Reginald plays half-back on the Harvard eleven.
12. Halifax is the capital of Nova Scotia.
13. Uncle Caleb unadvisedly invested all he had in mining stock.
14. Then Nora got a situation in a restaurant.
15. All delinquent taxes must be paid by June first.

MORION L. MITCHELL.

JAPANESE NUMERICAL ENIGMA.

I AM composed of forty-eight letters and form a Japanese proverb.

My 37-34-21-6-41-47 is a country at war with Japan. My 23-20-7-27-12 is what both countries must do. My 1-15-45-42-5-26-7 is what a slangy little boy said that each country was doing to the other. My 30-17-9 28-11-7-38 has often caused war. My 31-8-43 is what every Japanese seems willing to do for his country. My 36-25-3-14-33 is what many have met with at the hands of the enemy. My 46-32-19-39 is the relation of Korea to Japan. My 35-16-41-4-2-10-19 is that side to which a neutral should belong. My 42-22-24-34-44 is the mourning-flower of Japan. My 13-48-29-40-18 is the general of the Japanese army in Manchuria.

WALTER AUSHIN.

CONNECTED DIAMONDS.



- I. UPPER DIAMOND: 1. In read. 2. To drink. 3. Quick. 4. A small hole. 5. In read.
- II. LEFT-HAND DIAMOND: 1. In read. 2. The summit. 3. Corded. 4. To fondle. 5. In read.
- III. RIGHT-HAND DIAMOND: 1. In read. 2. To strike gently. 3. Risked. 4. To confine. 5. In read.
- IV. LOWER DIAMOND: 1. In read. 2. An extremity. 3. Fed. 4. A wooden nail. 5. In read.

AGNES R. LANE (Honor Member).



