

450 100 12

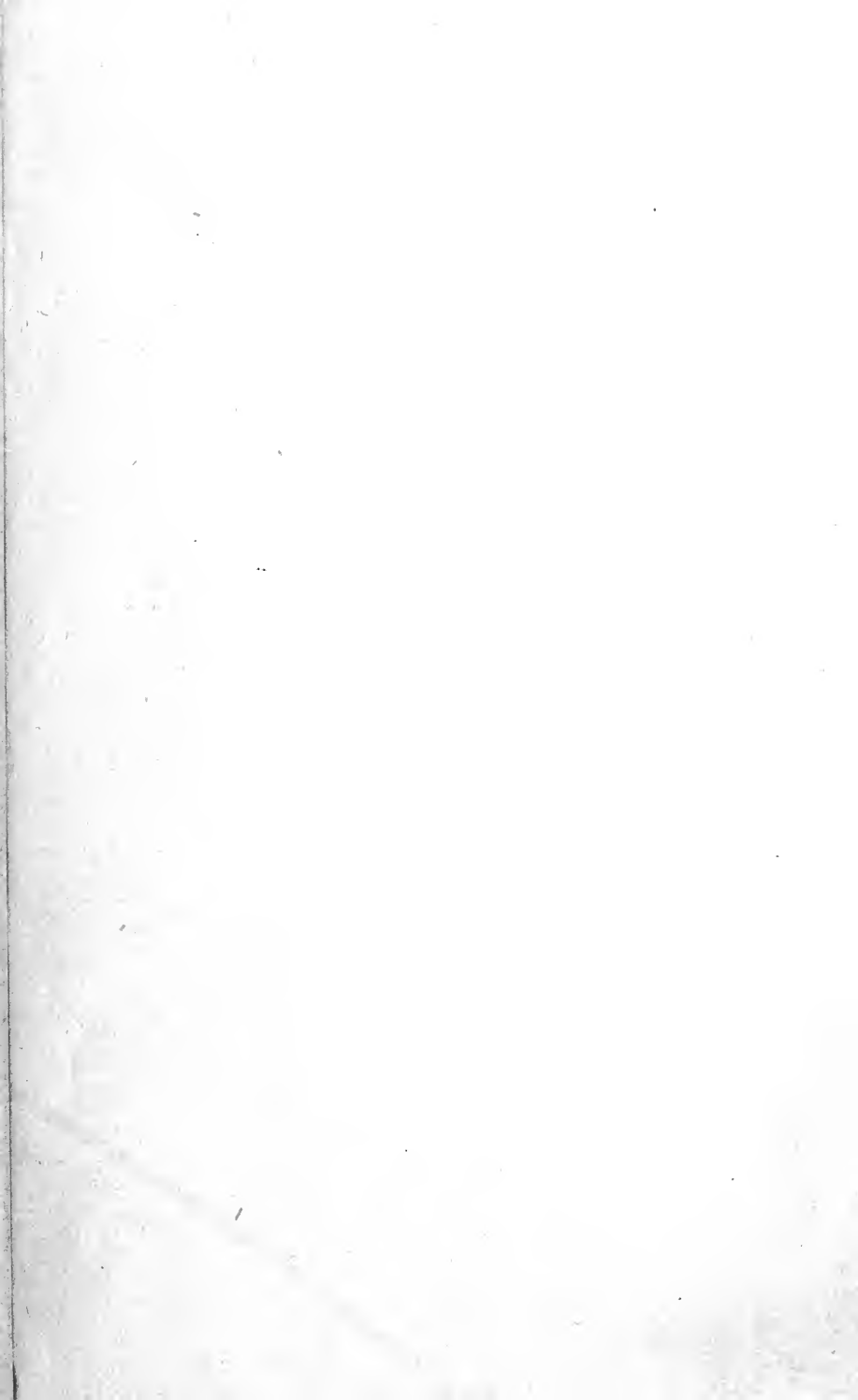





# Architecture, Building Construction, Strength of Materials, etc.

---

## THE ARCHITECTS' LIBRARY.

Edited by F. M. SIMPSON, F.R.I.B.A., Professor of Architecture in  
the University of London.

A HISTORY OF ARCHITECTURAL DEVELOPMENT. By  
F. M. SIMPSON. 3 vols. Medium 8vo, 10s. 6d. net each volume.

Vol. I. ANCIENT, EARLY CHRISTIAN, AND BYZANTINE. With  
180 Illustrations.

Vol. II. MEDIÆVAL. With 257 Illustrations.

Vol. III. THE RENAISSANCE IN ITALY, FRANCE AND ENGLAND.  
With 268 Illustrations.

BUILDING CONSTRUCTION. 2 vols. Medium 8vo, 10s. 6d. net  
each volume.

Vol. I. By BERESFORD PITE, F.R.I.B.A., F. T. BAGGALLAY,  
F.R.I.B.A., H. D. SEARLES-WOOD, F.R.I.B.A., E. SPRAGUE,  
Assoc. M.Inst.C.E. With 249 Illustrations.

Vol. II. By J. H. MARKHAM, A.R.I.B.A., HERBERT A. SATCHELL,  
F.R.I.B.A., Professor F. M. SIMPSON, F.R.I.B.A., and others.  
With Illustrations.

---

THE MECHANICS OF BUILDING CONSTRUCTION. By  
HENRY ADAMS, M.Inst.C.E., M.I.Mech.E., F.S.I., F.R.San.I.,  
etc.; Examiner in Building Construction to the Board of Education  
and the Society of Architects, late Professor of Engineering at the  
City of London College. With 590 Diagrams. 8vo, 6s. net.

ADVANCED BUILDING CONSTRUCTION. By the author of  
"Rivington's Notes on Building Construction." With 385 Illus-  
trations. Crown 8vo, 4s. 6d.

ELEMENTARY PRACTICAL BUILDING CONSTRUCTION.  
Stage I. By FRANK WILLIAM BOOKER. With 727 Illustrations.  
Crown 8vo, 2s. 6d.

BUILDING CONSTRUCTION. By EDWARD J. BURRELL. With  
303 Working Drawings. Crown 8vo, 2s. 6d.

---

LONGMANS, GREEN, & CO., LONDON, NEW YORK, BOMBAY, AND CALCUTTA.

**Architecture, Building Construction, Strength of Materials, etc.—cont.**

AN ENCYCLOPÆDIA OF ARCHITECTURE. By JOSEPH GWILT, F.S.A. Revised (1888), with Alterations and considerable Additions by WYATT PAPWORTH. With 1700 Engravings. 8vo, 21s. net.

A TEXT-BOOK OF THE HISTORY OF ARCHITECTURE. By A. F. HAMLIN, A.M. With 229 Illustrations. Crown 8vo, 7s. 6d.

RIVINGTON'S NOTES ON BUILDING CONSTRUCTION. Medium 8vo.

Part I.—695 Illustrations. 10s. 6d. net.

Part II.—496 Illustrations. 10s. 6d. net.

Part III.—Materials. 188 Illustrations. 18s. net.

Part IV.—Calculations for Building Structures. With 551 Illustrations. 13s. net.

BRICKLAYING AND BRICKCUTTING. By H. W. RICHARDS. With over 200 Illustrations. Medium 8vo, 3s. 6d.

THE VENTILATION, HEATING, AND MANAGEMENT OF CHURCHES AND PUBLIC BUILDINGS. By J. W. THOMAS. With 25 Illustrations. Crown 8vo, 2s. 6d.

THE VENTILATION, HEATING AND LIGHTING OF DWELLINGS. By J. W. THOMAS. With 72 Illustrations. Crown 8vo, 6s.

STRUCTURAL ENGINEERING. By JOSEPH HUSBAND, Associate Member and Watt Medallist, Inst. C.E., M. French Soc. C.E., A.R.C.Sc., Head of the Civil Engineering Department in the University of Sheffield; and WILLIAM HARBY, sometime Assistant in the Civil Engineering Department of the University of Sheffield. With 337 Diagrams. 8vo, 7s. 6d. net.

A POCKET-BOOK FOR MECHANICAL ENGINEERS. By DAVID ALLAN LOW (Whitworth Scholar), M.I.Mech.E., Professor of Engineering, East London Technical College. With over 1000 specially prepared Illustrations. Fcp. 8vo, gilt edges, rounded corners, 7s. 6d.

RAILWAY CONSTRUCTION. By W. H. MILLS, M.I.C.E., Engineer-in-Chief of the Great Northern Railway of Ireland. With 516 Illustrations. 8vo, 18s. net.

---

LONGMANS, GREEN, & CO., LONDON, NEW YORK, BOMBAY, AND CALCUTTA.

# STRENGTH OF MATERIALS

*BY THE SAME AUTHOR*

---

MECHANICS FOR ENGINEERS. A  
Text-book of Intermediate Standard.  
With 200 Diagrams and numerous  
Examples. Crown 8vo, 4s. net.

THE THEORY OF STRUCTURES.  
With Diagrams. 8vo, 7s. 6d. net.

ELEMENTARY APPLIED ME-  
CHANICS. By ARTHUR MORLEY,  
M.Sc., M.I.Mech.E., and WILLIAM  
INCHLEY, B.Sc. With 285 Diagrams,  
numerous Examples and Answers.  
Crown 8vo, 3s. net.

LONGMANS, GREEN, AND CO.  
LONDON, NEW YORK, BOMBAY  
AND CALCUTTA

# STRENGTH OF MATERIALS

BY

ARTHUR MORLEY, M.Sc., M.I.MECH.E.



*WITH 248 DIAGRAMS AND NUMEROUS EXAMPLES*

*THIRD EDITION*

LONGMANS, GREEN, AND CO.

• 39 PATERNOSTER ROW, LONDON  
NEW YORK, BOMBAY, AND CALCUTTA

1913

*All rights reserved*

TA 405

MM

1913

TO VNU  
ADDRESS

## PREFACE

THIS book has been written mainly for Engineering students, and covers the necessary ground for University and similar examinations in Strength of Materials; but it is hoped that it will also prove useful to many practical engineers, to whom a knowledge of the subject is necessary.

In some sections of the work well-established lines have been followed, but several special features may be mentioned. In Chap. II. the different theories of elastic strength are explained, and subsequently throughout the book the different formulæ to which they lead in cases of compound stress are pointed out. Considerable use has been made of the method of finding beam deflections from the moment of the area of the bending-moment diagram, *i.e.* from the summation  $\int \frac{Mx}{EI} dx$ ; my attention was called to the very simple application of this method to the solution of problems on built-in and continuous beams developed in Chap. VII., by my friend Prof. J. H. Smith, D.Sc. Other subjects treated, which have hitherto received but scant attention in text-books, include the strength of rotating discs and cylinders, the bending of curved bars with applications to hooks, rings, and links, the strength of unstayed flat plates, and the stresses and instability arising from certain speeds of running machinery. Most of the important research work bearing on Strength of Materials has been noticed, and numerous easily accessible references to original papers have been given. Most of the results involving even simple mathematical demonstrations have been worked out in detail; experience shows that careful readers lose much time through being unable to bridge easily the gaps frequently left in such work. Many fully worked-out numerical examples have been given, and the reader is advised to read all of these, and to work out for himself the examples given at the ends of the chapters, as being a great help to obtaining a sound and useful knowledge of the subject. Many readers will have the opportunity of seeing and using practical

testing appliances, and this portion of the work has been treated somewhat briefly in the last three chapters, ample references to works on testing and original papers being furnished.

I must acknowledge my great indebtedness to Prof. Karl Pearson's most valuable work of reference, "The History of the Theory of Elasticity," and to the treatises on testing by Profs. Unwin, J. B. Johnson, and A. Martens.

I take this opportunity of thanking numerous friends who have assisted me by suggestions, reading of MS. or proofs, or checking examples; particularly Prof. Goodman, M.Sc., Prof. W. Robinson, M.E., Prof. J. H. Smith, D.Sc.; Messrs. T. H. Gardner, B.Sc., W. Inchley, and G. A. Tomlinson, B.Sc.

I also express my thanks to the various makers of machines or instruments, and others, who have supplied me with blocks or photographs, and whose names appear in connection with the illustrations. It is too much to hope that this edition will be quite free from errors, and any intimation of these, or any other suggestion, will be cordially appreciated.

ARTHUR MORLEY.

UNIVERSITY COLLEGE, NOTTINGHAM,  
*September, 1908.*

## THIRD EDITION

NUMEROUS minor alterations, and corrections have been made, new references have been given, and Art. 93A and new matter in Art. 162 have been added.

A. M.

*July, 1912.*



# CONTENTS

## CHAPTER I.

### *ELASTIC STRESS AND STRAIN.*

Stress—Strain—Elastic limits—Elastic constants—Resolution of stress— Ellipse of stress—Principal planes and stresses—Principal strains . . .	PAGES 1-28
---	---------------

## CHAPTER II.

### *MECHANICAL PROPERTIES OF METALS.*

Elastic limit and yield point—Ductile strains—Ultimate and elastic strength— Factor of safety—Measures of ductility—Actual and nominal stress—Effect of shape of test pieces—Detailed properties of important metals—Raising the elastic limit by strain—Hysteresis—Hardening and annealing—Influence of rate of loading—Compression—Fractures—Effects of temperature—Stress due to temperature changes . . . . .	29-62
--	-------

## CHAPTER III.

### *RESILIENCE AND FLUCTUATING STRESS.*

Work done in tensile strain—Resilience—Live loads—Resistance to shock— Fatigue—Wöhler's experiments—Experiments of Reynolds and Smith, Stanton and Bairdow, and others—Limiting range of stress—Explanations of failure under fluctuating stress—Factors of safety . . . . .	63-85
---	-------

## CHAPTER IV.

### *THEORY OF BENDING.*

Straining actions—Shearing force and bending moments—Diagrams—Contra- flexure—Funicular polygon—Relation between bending moment and shear- ing force—Theory of bending—Simple and other bending . . . . .	86-110
---	--------

## CHAPTER V.

### *STRESSES IN BEAMS.*

Moments of inertia of sections—Graphical methods—Momental ellipsis— Concrete steel sections—Beams of uniform strength—Distribution of shear stress—Pitch of girded rivets—Principal stresses—Bending beyond elastic limit—Modulus of rupture—Unsymmetrical bending . . . . .	111-152
---	---------

## CHAPTER VI.

*DEFLECTION OF BEAMS.*

Uniform curvature—Relations between curvature, slope, and deflection—Various cases—Propped beams—Deflection and slope from bending-moment diagrams, with applications—Other graphical methods—Beams of varying cross-section—Carriage springs . . . . .	PAGES 153-192
---	------------------

## CHAPTER VII.

*BUILT-IN AND CONTINUOUS BEAMS.*

Simple cases—Effect of fixed ends—Symmetrical loading—Any loading—Varying section—Theorem of three moments—Simple and general cases—Wilson's method—Advantages and disadvantages of continuous beams . . . . .	193-225
--	---------

## CHAPTER VIII.

*SECONDARY EFFECTS OF BENDING.*

Resilience of beams—Deflections from resilience—Carriage springs—Impacts producing flexure—Transverse curvature—Shearing resilience and deflections due to shearing . . . . .	226-241
---	---------

## CHAPTER IX.

*DIRECT AND BENDING STRESSES.*

Combined bending and direct stress—Eccentric loads—Masonry seatings for beams—Pillars, columns, and struts—Euler's theory—Use of Euler's formulæ—Rankine's and other formulæ—Comparison with experiments—Eccentric loads on long columns—Struts and tie-rods with lateral loads . . . . .	242-276
---	---------

## CHAPTER X.

*TWISTING.*

Stress and strain in pure torsion—Relation to twisting effort—Hollow shafts—Non-circular shafts—Combined bending and torsion—Effect of end thrust—Torsion beyond elastic limit—Torsional resilience—Helical spring close coiled and open coiled . . . . .	277-298
---	---------

## CHAPTER XI.

*PIPES, CYLINDERS, AND DISCS.*

Thin cylindrical shell—Oval sections—Seams—Thin spherical shell—Thick cylinders—Thick spherical shell—Compound cylinders—Rotating ring or wheel rim—Rotating disc—Rotating cylinder—Rotating disc of varying thickness . . . . .	299-331
--	---------

## CHAPTER XII.

*BENDING OF CURVED BARS.*

Theory of bending—Various sections—Stresses in hooks—Stresses in rings—Deformation of rings—Simple chain links—Flat spiral springs—Arched ribs with three and with two hinges—Fixed ribs—Temperature stresses—Hanging wires and chains . . . . .	332-377
--	---------

CHAPTER XIII.

*FLAT PLATES.*

Stress and strain in circular plate—Free and fixed plates—Distributed and central loads—Uniform load and central support—Approximate methods for non-circular plates—Oval, square, and rectangular plates . . .	PAGES 378-400
---	------------------

CHAPTER XIV.

*VIBRATIONS AND CRITICAL SPEEDS.*

Elastic vibrations—Free vibrations—Forced vibrations—Critical frequency—Dangerous speeds—Longitudinal vibrations—Transverse vibrations—Loaded and unloaded rods—Whirling speeds of shafts—Stress and deflection—Vibrations of rotating shaft—Effect of end thrust and twist—Torsional vibrations . . . . .	401-425
--	---------

CHAPTER XV.

*TESTING MACHINES, APPARATUS AND METHODS.*

Typical testing machines—Tension tests—Form of test pieces—Methods of gripping—Shearing tests—Calibration of testing machine—Torsion testing machine—Extensometers—Autographic recorders—Beam deflections—Torsional strains—Tension and torsion of wires—Bending of light beams—Determination of elastic constants (summary) . . . . .	426-453
--	---------

CHAPTER XVI.

*SPECIAL TESTS.*

Repeated and reversed stresses—Smith's, Arnold's, and Sankey's machines—Single bend tests—Hardness tests and testing machines—Impact tests and machines . . . . .	454-466
---	---------

CHAPTER XVII.

*SPECIAL MATERIALS.*

Cement tests, machines and apparatus—Concrete, stone, and brick—Timber, strength and tests—Tension, compression, shearing, and bending tests—Prolonged loading—Strength of wire ropes . . . . .	467-480
---	---------

ANSWERS TO EXAMPLES . . . . .	481-486
-------------------------------	---------

MATHEMATICAL TABLES . . . . .	487-491
-------------------------------	---------

INDEX . . . . .	493-497
-----------------	---------



# STRENGTH OF MATERIALS

## CHAPTER I.

### *ELASTIC STRESS AND STRAIN.*

1. THE subject generally called *Strength of Materials* includes the study of the distribution of internal forces, the stability and deformation of various elements of machines and structures subjected to straining actions. It is founded partly on the result of experiment and partly on conclusions drawn therefrom by the application of the principles of mechanics and mathematics. Except in very simple cases, the demonstrations are less rigorous than those which form the Mathematical Theory of Elasticity, an exact science which is unable to furnish solutions for the majority of the practical problems which present themselves to the engineer in the design of machines and structures. The semi-empirical nature of the subject makes it desirable that its formulæ should, wherever possible, be tested by experiment, and that in all cases the limits within which the theories may represent the facts should be clearly appreciated. In proportioning the parts of machines and structures, various considerations other than strength and stiffness, such, for example, as cost, lubrication, and durability, play an important part, but rationally used, the results obtained in the subject of Strength of Materials form an important part of the basis of the scientific design of machines and structures.

2. **Stress.**—The equal and opposite action and reaction which take place between two bodies, or two parts of the same body, transmitting forces constitute a stress. If we imagine a body which transmits a force to be divided into two parts by an ideal surface, and interaction takes place across this surface, the material there is said to be stressed or in a state of stress. The constituent forces, and therefore the stress itself, are distributed over the separating surface either uniformly or in some other manner. The *intensity of the stress* at a surface, generally referred to with less exactness as merely the stress, is estimated by the force transmitted per unit of area in the case of uniform distribution, this is also called the *unit stress*; if the distribution is not uniform, the stress intensity at a point in the surface must be looked upon as the limit of the ratio of units of force to units of area when each is decreased indefinitely.

3. **Simple Stresses.**—There are two specially simple states of stress

which may exist within a body. More complex stresses may be split into component parts.

(1) *Tensile stress* between two parts of a body exists when each draws the other towards itself. The simplest example of material subject to tensile stress is that of a tie-bar sustaining a pull. If the pull on the tie-bar is say  $P$  lbs., and we consider any imaginary plane of section  $X$  perpendicular to the axis of the bar, of area  $a$  square inches, dividing the bar into two parts  $A$  and  $B$  (Fig. 1), the material at the

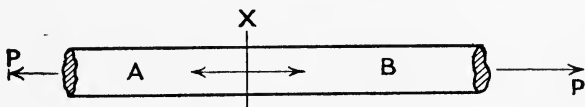

FIG. 1.

section  $X$  is under a tensile stress. The portion  $B$ , say, exerts a pull on the portion  $A$  which just balances  $P$ , and is therefore equal and opposite to it. The average force exerted per square inch of section is—

$$p = \frac{P}{a}$$

and this value  $p$  is the mean intensity of tensile stress at this section.

(2) *Compressive stress* between two parts of a body exists when each pushes the other from it.

If a bar (Fig. 2) sustains an axial thrust of  $P$  tons at each end, at a

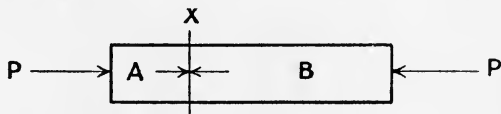

FIG. 2.

transverse section  $X$  of area  $a$  square inches, dividing the bar into two parts  $A$  and  $B$ , the material is under compressive stress. The portion  $A$ , say, exerts a push on the portion  $B$  equal and opposite to that on the far end of  $B$ . The average force per square inch of section is—

$$p = \frac{P}{a}$$

and this value  $p$  is the mean intensity of compressive stress at the section  $X$ .

*Shear stress* exists between two parts of a body in contact when the two parts exert equal and opposite forces on each other laterally in a direction tangential to their surface of contact. As an example, there is a shear stress at the section  $XY$  of a pin or rivet (Fig. 3) when the two plates which it holds together sustain a pull  $P$  in the plane of the section  $XY$ . If the area of section  $XY$  is  $a$  square inches, and the pull is  $P$

tons, the total shear at the section XY is P tons, and the average force per square inch is—

$$q = \frac{P}{a}$$

This value  $q$  is the mean intensity of shear stress at the section XY.

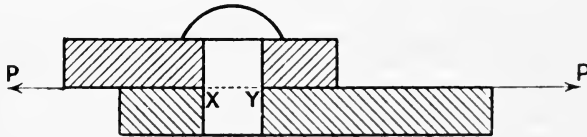

FIG. 3.

**4. Strain.**—Strain is the alteration of shape or dimensions resulting from stress.

(1) Tensile strain is the stretch, and often results from a pull which causes a condition of tensile stress to be set up. It is in the direction of the tensile stress, and is measured by the fractional elongation. Thus, if a length  $l$  units is increased to  $l + \delta l$ , the strain is—

$$\frac{\delta l}{l}$$

The strain is obviously equal numerically to the stretch per unit of length.

(2) Compressive strain is the contraction which is often due to compressive stress, and is measured by the ratio of the contraction to the original length. If a length  $l$  contracts to  $l - \delta l$ , the compressive strain is—

$$\frac{\delta l}{l}$$

Tensile stress causes a contraction perpendicular to its own direction, and compressive stress causes an elongation perpendicular to its own direction.

(3) Distortional or shear strain is the angular displacement produced by shear stress. If a piece of material be subjected to a pure shear stress in a certain plane, the change in inclination (estimated in radians) between the plane and a line originally perpendicular to it, is the numerical measure of the resulting shear strain (see Art. 10).

**5. Elastic Limits.**—The limits of stress for a given material within which the resulting strain completely disappears after the removal of the stress are called the elastic limits. If a stress beyond an elastic limit is applied, part of the resulting strain remains after the removal of the stress; such a residual strain is called a permanent set. The determination of an elastic limit will evidently depend upon the detection of the smallest possible permanent set, and gives a lower stress when instruments of great precision are employed than with cruder

methods. In some materials the time allowed for strain to develop or to disappear will affect the result obtained.

Elastic strain is that produced by stress within the limits of elasticity; but the same term is often applied to the portion of strain which disappears with the removal of stress even when the elastic limits have been exceeded.

*Hooke's Law* states that within the elastic limits the strain produced is proportional to the stress producing it. The law refers to all kinds of stress.

This law is not exactly true for all materials, but is approximately so for many; some small deviations from it will be noticed later.

**6. Modulus of Elasticity.**—Assuming the truth of Hooke's Law, we may write—

$$\text{intensity of stress} \propto \text{strain}$$

or

$$\text{stress intensity} = \text{strain} \times \text{constant}$$

The constant in this equation is called the modulus or coefficient of elasticity, and will vary with the kind of stress and strain contemplated, there being for each kind of stress a different kind of modulus. Since the strain is measured as a mere number, and has no dimensions of length, time, or force, the constant is a quantity of the same kind as a stress intensity, being measured in units of force per unit of area, such as pounds or tons per square inch. We might define the modulus of elasticity as the intensity of stress which would cause unit strain, if the material continued to follow the same law outside the elastic limits as within them, or as the intensity of stress per unit of strain.

**7. Components of Oblique Stresses.**—When the stress across any given surface in a material is neither normal nor tangential to that surface, we may conveniently resolve it into rectangular components, normal to the surface and tangential to it. The normal stresses are tensile or compressive according to their directions, and the tangential components are shear stresses.

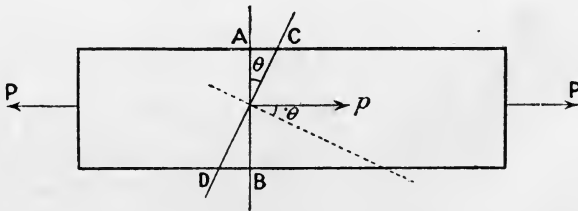

FIG. 4.

A simple example will illustrate the method of resolution of stress. If a parallel bar of cross-section  $a$  square inches be subjected to a pull of  $P$  tons, the intensity of tensile stress  $p$  is  $\frac{P}{a}$  in the direction of the length of the bar, or, in other words, normal to a surface,  $AB$  (Fig. 4), perpendicular to the line of pull.



Let  $p_n$  and  $p_t$  be the component stress intensities, normal and tangential respectively, to a surface, CD, which makes an angle  $\theta$  with the surface AB. Resolving the whole force P normal to CD, the component is—

$$P_n = P \cos \theta$$

and the area of the surface CD is

$$a \sec \theta$$

hence

$$p_n = \frac{P \cos \theta}{a \sec \theta} = \frac{P}{a} \cos^2 \theta = p \cos^2 \theta$$

and resolving along CD, the tangential component of the whole force is—

$$P_t = P \sin \theta$$

$$p_t = \frac{P \sin \theta}{a \sec \theta} = \frac{P}{a} \sin \theta \cos \theta = p \sin \theta \cos \theta, \text{ or } \frac{p}{2} \sin 2\theta$$

Evidently  $p_t$  reaches a maximum value  $\frac{1}{2}p$  when  $\theta = 45^\circ$ , so that all surfaces, curved or plane, inclined  $45^\circ$  to AB (and therefore also to the axis of pull) are subjected to maximum shear stress. In testing materials in tension or compression, it often happens that fracture takes place by shearing at surfaces inclined at angles other than  $90^\circ$  to the axis of pull.

EXAMPLE.—The material of a tie-bar has a uniform tensile stress of 5 tons per square inch. What is the intensity of shear stress on a plane the normal of which is inclined  $40^\circ$  to the axis of the bar? What is the intensity of normal stress on this plane, and what is the resultant intensity of stress?

Considering a portion of the bar, the section of which is 1 square inch normal to the axis, the pull is 5 tons. The area on which this load is spread on a plane inclined  $40^\circ$  to the perpendicular cross-section is—

$$(1 \times \sec 40^\circ) \text{ square inch}$$

and the amount of force resolved parallel to this oblique surface is—

$$(5 \times \sin 40^\circ) \text{ tons}$$

hence the intensity of shearing stress is—

$$5 \sin 40^\circ \div \sec 40^\circ = 5 \sin 40^\circ \cos 40^\circ = 5 \times 0.6428 \times 0.7660 \\ = 2.462 \text{ tons per square inch}$$

The force normal to this oblique surface is—

$$5 \cos 40^\circ$$

hence the intensity of normal stress is—

$$5 \cos 40^\circ \div \sec 40^\circ = 5 \cos^2 40^\circ = 5 \times 0.766 \times 0.766 \\ = 2.933 \text{ tons per square inch}$$

The resultant stress is in the direction of the axis of the bar, and its intensity is—

$$5 \div \sec 40^\circ = 5 \cos 40^\circ = 3.83 \text{ tons per square inch}$$

**8. Complementary Shear Stresses. State of Simple Shear.**—A shear stress in a given direction cannot exist without a balancing shear stress of equal intensity in a direction at right angles to it.

If we consider a small rectangular block, ABCD, of material (Fig. 5) under shear stress of intensity  $q$ , we cannot have equilibrium with merely equal and opposite tangential forces on the parallel pair of faces AB and CD: these forces constitute a couple, and alone exert a turning

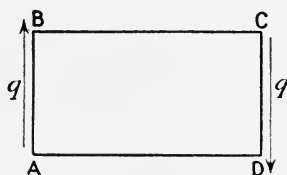

FIG. 5.

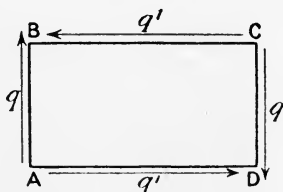

FIG. 6.

moment. Statical considerations of equilibrium show that in this case no additional system of forces can balance the couple and produce the equilibrium unless they result in a couple contrary to the previous one; hence there must be tangential components along AD and CB, such as to balance the moments of the forces on AB and CD whether there are in addition normal forces or not. If there is a tangential stress exerting force along AD and CB (Fig. 6), and its intensity be  $q'$ , and the thickness of the block ABCD perpendicular to the figure be  $l$ , the forces on AB, BC, CD, and DA are—

$$AB.l.q, \quad BC.l.q', \quad CD.l.q, \quad \text{and} \quad DA.l.q'$$

respectively, and equating the moments of the two couples produced—

$$AB.l.q \times BC = BC.l.q' \times AB$$

hence

$$q = q'$$

That is, the intensities of shearing stresses across two planes at right angles are equal; this will remain true whatever normal stresses may act, or, in other words, whether  $q$  and  $q'$  are component or resultant stresses on the perpendicular planes.

*Simple Shear.*—The state of stress shown in Fig. 6, where there are only the shear stresses of equal intensity  $q$ , is called simple shear. To find the stress existing in other special directions, take a small block ABCD (Fig. 7), the sides of the square face ABCD being each  $s$  and the length of the block perpendicular to the figure being  $l$ . Considering the equilibrium of the piece BCD, resolve the forces  $q$  perpendicularly to the diagonal BD, and we must have a force

$$2.q.s.l \cos 45^\circ, \text{ or } 2 \frac{qs'l}{\sqrt{2}}$$

acting on the face BD.

The area of BD is  $BD \times l = \sqrt{2} \cdot s \cdot l$

Therefore if  $p_n$  is the intensity of normal stress on the face BD,

$$p_n \times \sqrt{2} \cdot s \cdot l = \frac{2}{\sqrt{2}} \cdot q \cdot s \cdot l$$

hence

$$p_n = q$$

and  $p_n$  is evidently compressive.

Similarly the intensity of *tensile* stress on a plane AC is evidently equal numerically to  $q$ .

Further by resolving along BD or AC the intensity of the tangential stress on such planes is evidently zero. Hence a state of simple shear produces pure tensile and compressive stresses across planes inclined  $45^\circ$

to those of pure shear, and the intensities of these direct stresses are each equal to the intensities of the pure shear stress.

**9. Three Important Elastic Constants.**—Three moduli of elasticity (Art. 6) corresponding to three simple states of stress are important.

**Young's Modulus**, also called the Stretch or Direct Modulus, is the Modulus of Elasticity for pure tension with no other stress acting; it has in most materials practically the same value for compression; it is always denoted by the letter E. This direct modulus of elasticity is equal to the tensile (or compressive) stress per unit of linear strain (Art. 6). If a tensile stress  $p$  tons per square inch cause a tensile strain  $e$  (Art. 4), intensity of tensile stress = tensile strain  $\times$  E

$$\text{or} \quad p = e \times E$$

$$\text{hence} \quad E = \frac{p}{e} = \frac{\text{tensile stress intensity}}{\text{tensile strain}}$$

and is expressed in the same units (tons per square inch here) as the stress  $p$ .

The value of E for steel or wrought iron is about 13,000 tons per square inch.

**EXAMPLE 1.**—Find the elongation in a steel tie-bar 10 feet long and 1.5 inches diameter, due to a pull of 12 tons.

$$\text{Area of section} = 1.5 \times 1.5 \times 0.7854 = 1.767 \text{ square in.}$$

$$\text{Stress intensity} = \frac{12}{1.767} = 6.79 \text{ tons per square in.}$$

$$\text{Strain} = \frac{6.79}{13,000}$$

$$\text{Elongation} = \frac{6.79}{13,000} \times 10 \times 12 = 0.0627 \text{ in.}$$

**EXAMPLE 2.**—A long copper rod one inch diameter fits loosely in a steel tube  $\frac{1}{8}$  inch thick, to which it is rigidly attached at its ends. The compound bar so formed is then pulled with a force of 10 tons. Find

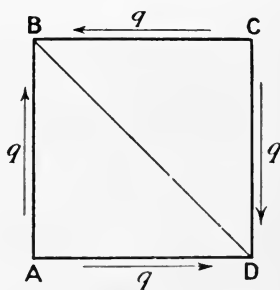

FIG. 7.

the stress intensity in each metal ( $E = 13,000$  tons per square inch for steel, and 6000 for copper).

Let  $p_1$  be the stress intensity in the steel and  $p_2$  that in the copper.

The strain being the same in each,

$$\frac{p_1}{13,000} = \frac{p_2}{6000}$$

$$p_1 = \frac{13}{6} p_2$$

The area of copper section is 0.7854 square inch, and the steel section is 0.4417 square inch.

The total load

$$10 \text{ tons} = 0.4417 p_1 + 0.7854 p_2$$

hence

$$10 = p_2 (0.4417 \times \frac{13}{6} + 0.7854)$$

$$p_2 = \frac{10}{1.7424} = 5.74 \text{ tons per square in.}$$

and

$$p_1 = 12.43 \text{ tons per square in.}$$

**10. Modulus of Rigidity, Modulus of Transverse Elasticity, or Shearing Modulus,** is the modulus expressing the relation between the intensity of shear stress and the amount of shear strain. It is denoted by the letter  $N$ , also sometimes by  $C$  or  $G$ . If the shearing strain (Art. 4) is  $\phi$  (radians) due to a shear stress of intensity  $q$  tons per square inch, then

$$\text{shear stress} = \text{shear strain} \times N$$

or

$$q = \phi \times N$$

$$N \text{ (tons per square in.)} = \frac{q}{\phi} = \frac{\text{shear stress}}{\text{shear strain}}$$

The value of  $N$  for steel is about  $\frac{2}{5}$  of the value of  $E$ .

*Strains in Simple Shear.*—A square face,  $ABCD$  (Fig. 8), of a piece of material under simple shear stress, as in Art 8, will suffer a strain

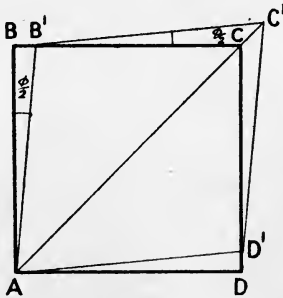

FIG. 8.

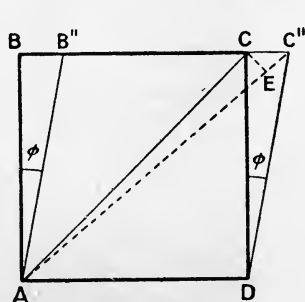

FIG. 9.

such as is indicated, by taking the new shape  $AB'C'D'$ . For expressing the strain it is slightly more convenient to consider the side  $AD$ , say, fixed, and the new shape accordingly, as in Fig. 9,  $AB''C''D$ . The

strains being extremely small quantities, the straight line  $BB''$  practically coincides with an arc struck with centre  $A$ , and a line  $CE$  drawn perpendicular to  $AC''$  is substantially the same as an arc centred at  $A$ . The shear strain (Art. 4)  $\phi$  radians is (Fig. 9)

$$\frac{BB''}{AB} \text{ or } \frac{CC''}{CD}, \text{ and is equal to } \frac{q}{N} \text{ as above.}$$

The elongation of the diagonal  $AC$  is equal to  $EC''$ , and the linear strain is

$$\frac{EC''}{AC} = \frac{CC'' \times \frac{1}{\sqrt{2}}}{CD \times \sqrt{2}} = \frac{1}{2} \cdot \frac{CC''}{CD} = \frac{1}{2}\phi \text{ or } \frac{1}{2} \cdot \frac{q}{N}$$

That is, the strain in this direction is numerically half the amount of the shear strain. Similarly, the strain along the direction  $BD$  is  $\frac{1}{2}\phi$ , but dimensions in this direction are shortened. These are the strains corresponding to the direct stresses of intensities equal to  $q$  produced across diagonal planes, as in Art. 8, by the shear stresses. Note that the strain along  $AC$  is *not* simply  $\frac{p_n}{E}$ , because in addition to the tensile stress  $p_n$  there is a compressive stress of equal intensity at right angles to it.

**11. Bulk Modulus** is that corresponding to the volumetric strain resulting from three mutually perpendicular and equal direct stresses, such as the slight reduction in bulk a body suffers, for example, when immersed in a liquid under pressure: this modulus is generally denoted by the letter  $K$ .

If the intensities of the equal normal stresses are each  $p$ ,

$$\frac{p}{K} = \text{volumetric strain} = \frac{\text{change in volume}}{\text{original volume}}$$

The volumetric strain is three times the accompanying linear strain, for if we consider a cube of side  $a$  strained so that each side becomes

$$a \pm \delta a,$$

where  $\delta a$  is very small, the linear strain is

$$\frac{\delta a}{a}$$

The volumetric change is  $(a \pm \delta a)^3 - a^3$ , or

$$\pm 3a^2\delta a$$

to the first order of small quantities. The strain then is

$$\frac{3a^2\delta a}{a^3} = 3 \cdot \frac{\delta a}{a}$$

which is three times the linear strain  $\frac{\delta a}{a}$ , or, in other words, the linear strain is one-third of the volumetric strain.

12. **Poisson's Ratio.**—Direct stress produces a strain in its own direction and an opposite kind of strain in every direction perpendicular to its own. Thus a tie-bar under tensile stress extends longitudinally and contracts laterally. Within the elastic limits the ratio

$$\frac{\text{lateral strain}}{\text{longitudinal strain}}$$

generally denoted by  $\frac{1}{m}$ , is a constant for a given material. The value of  $m$  is usually from 3 to 4, the ratio  $\frac{1}{m}$  being about  $\frac{1}{4}$  for many metals. This ratio, which was formerly suggested as being for all materials  $\frac{1}{4}$ , is known as *Poisson's Ratio*.

13. **Relations between the Elastic Constants.**—Some relations between the above quantities  $E$ ,  $N$ ,  $K$ , and  $m$  may be simply deduced. The strain of the diagonal of a square block of material in simple shear of intensity  $q$  or  $p$  was (Art. 10) found to be  $\frac{1}{2}\frac{q}{N}$ , which by Art. 8 may be replaced by  $\frac{1}{2}\frac{p}{N}$ , where  $p$  is the intensity of the equal and opposite direct stresses across diagonal planes.

The resulting direct stress  $p$  (Art. 8) in the direction of a diagonal would, if acting alone, cause a strain  $\frac{p}{E}$  in the direction of that diagonal, and the opposite kind of direct stress in the direction of the diagonal perpendicular to the first would, acting alone, cause a similar kind of strain to the above one, amounting to  $\frac{1}{m} \cdot \frac{p}{E}$  in the direction of the first-mentioned diagonal.

Hence, the total strain of the diagonal is

$$\frac{1}{2}\frac{p}{N} = \frac{p}{E} \left( 1 + \frac{1}{m} \right)$$

from which

$$\frac{1}{2N} = \frac{1}{E} \left( 1 + \frac{1}{m} \right)$$

or

$$E = 2N \left( 1 + \frac{1}{m} \right) \dots \dots \dots (1)$$

Note that if  $m = 4$ ,  $\frac{E}{N} = \frac{5}{2}$ .

Again, consider a cube of material under a direct normal stress  $p$ , say compressive, in each of the three perpendicular directions parallel to its edges (Fig. 10). Each edge is shortened by the action of the forces parallel to that edge, and the amount of such strain is

$$\frac{p}{E}$$

Again each edge is lengthened by the action of the two pairs of forces perpendicular to that edge and the amount of such strain is

$$2 \times \frac{l}{m} \cdot \frac{p}{E}$$

The total linear strain of each edge is then

$$\frac{p}{E} \left( 1 - \frac{2}{m} \right)$$

and the volumetric strain is therefore

$$3 \cdot \frac{p}{E} \left( 1 - \frac{2}{m} \right) \text{ (Art. 11)}$$

which is also by definition

$$\frac{p}{K}$$

where  $K$  is the bulk modulus.

Therefore 
$$\frac{p}{K} = 3 \frac{p}{E} \left( 1 - \frac{2}{m} \right)$$

or

$$\frac{l}{K} = 3 \left( 1 - \frac{2}{m} \right)$$

$$E = 3K \left( 1 - \frac{2}{m} \right) \dots \dots \dots (2)$$

Hence from (1) and (2)

$$E = 2N \left( 1 + \frac{l}{m} \right) = 3K \left( 1 - \frac{2}{m} \right)$$

Eliminating  $E$ , this gives

$$\frac{l}{m} = \frac{3K - 2N}{6K + 2N} \dots \dots \dots (3)$$

also, eliminating  $m$ ,

$$E = \frac{9KN}{N + 3K} \dots \dots \dots (4)$$

*Alternative method.*—We may also obtain these results by another slightly artificial method.

Imagine a cube  $ABC \dots H$  (Fig. 11), of, say, unit side cut from the interior of a piece of material having a uniform tension of intensity  $p$  in a direction parallel to  $AD$ . Now imagine the forces  $p$  on the faces  $ABFE$  and  $DHGC$  each split up into three equal parts  $\frac{p}{3}$ , and further, equal and opposite (balanced) normal forces  $\frac{p}{3}$  acting on each lateral face of the cube: these forces being neutralised will produce no effect. The

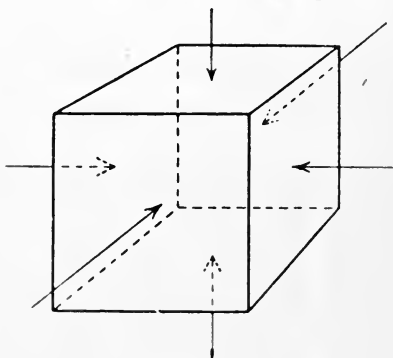

FIG. 10.

state of the forces is represented in Fig. 12. We may regard the cube as simultaneously under the three sets of forces shown in Fig. 13 (a),

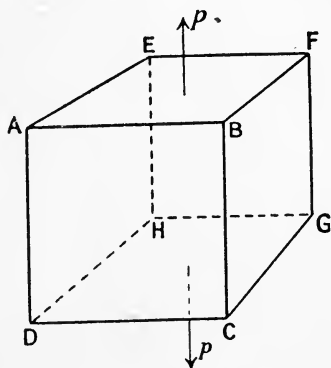

FIG. 11.

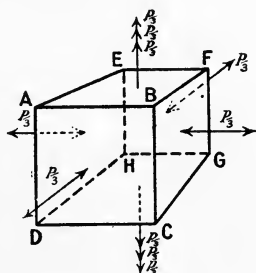

FIG. 12.

(b), and (c), all of these together corresponding exactly to the forces shown in Fig. 12.

(a) represents such a state of stress as that mentioned in Art. 11.

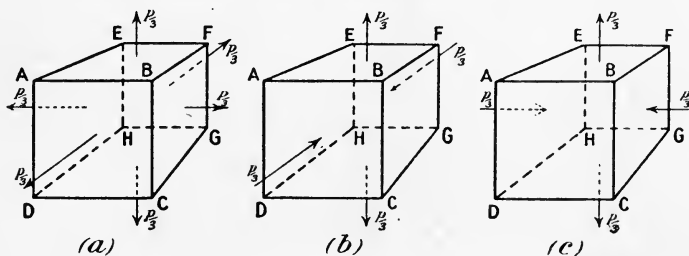

FIG. 13.

(b) and (c) represent pure shears on planes inclined  $45^\circ$  to the direction AD, as in Arts. 8 and 10.

Corresponding to (a) all edges suffer tensile strain

$$\frac{1}{3} \cdot \frac{p}{3} \div K$$

Corresponding to (b), all edges parallel to the original tensile stress have a tensile strain

$$\frac{1}{2} \cdot \frac{p}{3} \div N \text{ (Art. 10)}$$

and the transverse edges AE, BF, CG, and DH are shortened by a strain

$$\frac{1}{2} \cdot \frac{p}{3} \div N$$



Similarly, due to the state (c), all longitudinal edges are lengthened, taking a linear strain  $\frac{1}{2} \cdot \frac{p}{3} \div N$ , and the remaining transverse edges AB, EF, DC, and HG, get the compressive strain  $\frac{1}{2} \cdot \frac{p}{3} \div N$ .

Finally, then, the longitudinal strain throughout is an elongation and its amount is

$$\frac{p}{9K} + \frac{p}{6N} + \frac{p}{6N} \quad \text{or} \quad \frac{p}{9K} + \frac{p}{3N}$$

and the transverse compressive strain is

$$\frac{p}{6N} - \frac{p}{9K}$$

$$\text{Hence, } \frac{1}{m} = \frac{\text{transverse strain}}{\text{longitudinal strain}} = \frac{\frac{1}{6N} - \frac{1}{9K}}{\frac{1}{3N} + \frac{1}{9K}} = \frac{3K - 2N}{6K + 2N}$$

corresponding to (3) above.

Also the longitudinal strain is

$$\frac{p}{E}$$

Therefore

$$\frac{1}{E} = \frac{1}{9K} + \frac{1}{3N}$$

whence

$$E = \frac{9KN}{N + 3K}$$

as in (4) above.

EXAMPLE.—For a given material Young's modulus is 6000 tons per square inch, and the modulus of rigidity is 2300 tons per square inch. Find the bulk modulus and the lateral contraction of a round bar one inch in diameter and 10 feet long when stretched 0.1 inch.

From (1), Art. 13,

$$1 + \frac{1}{m} = \frac{E}{2N} = \frac{6000}{4600} = 1\frac{7}{23}$$

therefore

$$m = \frac{23}{7}$$

From (2), Art. 13,

$$K = \frac{E}{3\left(1 - \frac{2}{m}\right)} = \frac{6000}{3\left(1 - \frac{14}{23}\right)} = \frac{46000}{9} = 5111 \text{ tons per sq. in.}$$

$$\text{Lateral strain} = \frac{7}{23} \times \frac{0.1}{12 \times 10}$$

$$\left. \begin{array}{l} \text{Lateral contrac-} \\ \text{tion} \end{array} \right\} = \frac{7}{27600} = 0.000254 \text{ in.}$$

14. **Compound Stresses.**—When a body is under the action of several forces which cause wholly normal or wholly tangential stresses across different planes in known directions, we may find the state of stress across other planes by adding algebraically the various tangential components, and the components normal to such planes, and combining the sums according to the rules of statics.

*Principal Planes.*—Planes through a point within a material such that the resultant stress across them is wholly a normal stress are called *Principal Planes*, and the normal stresses across them are called the *Principal Stresses* at that point: the directions of the principal stresses are called the axes of stress.

However complex the state of stress at a point within a body, there always exist three mutually perpendicular principal planes, and stresses at that point may be resolved wholly into the three corresponding normal stresses: further the stress intensity across one of these principal planes is, at the point, greater than in any other direction, and another of the principal stresses is less than the stress in any other direction.

In many practical cases there is a plane perpendicular to which there is practically no stress, or in other words, one of the principal stresses is zero or negligibly small; in these cases resolution and compounding of stresses becomes a two-dimensional problem as in coplanar statics. We now proceed to investigate a few simple cases.

15. **Two Perpendicular Normal Stresses.**—If there be known normal stresses across two mutually perpendicular planes and no stress across the plane perpendicular to both of them, it is required to find the stress across any oblique interface perpendicular to that plane across which there is no stress. Let  $p_x$  and  $p_y$  be the given stress intensities normal

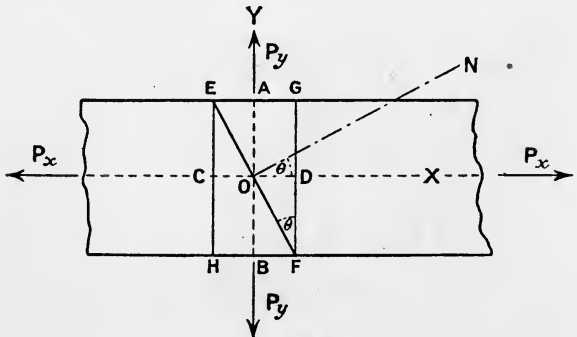

FIG. 14.

to the mutually perpendicular planes, say in directions OX and OY. If  $p_x$  and  $p_y$  vary along the directions OX and OY, we might consider the equilibrium of an indefinitely small element of material. If not, however, we may take a piece such as EGFH (Fig. 14), of unit thickness perpendicular to the figure. Our problem is to find the magnitude and direction of the resultant stress on a plane face EF, inclined  $\theta$

to all planes which are perpendicular to the axis OX, or the normal ON of which is inclined  $\theta$  to OX,  $\left(\frac{\pi}{2} - \theta\right)$  to OY and in the plane of the figure, perpendicular to which the stress is *nil*. The stresses  $p_x$  and  $p_y$  are here shown alike, but for unlike stresses the problem is not seriously altered.

The whole normal force on the face FG is

$$P_x = p_x \times FG$$

the area being  $FG \times$  unity.

The wholly normal force on EG is

$$P_y = p_y \times EG$$

Let  $p_n$  and  $p_t$  be the normal and tangential stress intensities respectively on the face EF reckoned positive in the directions ON and OF. Then considering the equilibrium of the wedge EGF, resolving forces in the direction ON,

$$\begin{aligned} p_n \times EF &= P_x \cos \theta + P_y \cos \left(\frac{\pi}{2} - \theta\right) \\ &= p_x \cdot FG \cdot \cos \theta + p_y \cdot EG \cdot \sin \theta \end{aligned}$$

dividing by EF

$$p_n = p_x \cos^2 \theta + p_y \sin^2 \theta \quad \dots \quad (1)$$

Resolving in direction OF

$$\begin{aligned} p_t \times EF &= P_x \sin \theta - P_y \cos \theta \\ &= p_x \cdot FG \cdot \sin \theta - p_y \cdot EG \cdot \cos \theta \end{aligned}$$

dividing by EF

$$p_t = (p_x - p_y) \sin \theta \cos \theta = \frac{p_x - p_y}{2} \sin 2\theta \quad \dots \quad (2)$$

If  $\theta = 45^\circ$ , the shear stress intensity

$$p_t = \frac{p_x - p_y}{2}$$

and is a maximum.

Across this same plane the direct (tensile) stress intensity is—

$$p_n = p_x \cos^2 45^\circ + p_y \sin^2 45^\circ = \frac{p_x + p_y}{2}$$

Combining (1) and (2), if  $p$  is the intensity of the resultant stress, since the two forces  $P_x$  and  $P_y$  are equal to the rectangular components of the force  $p \times EF$ ,

$$\begin{aligned} p \cdot EF &= \sqrt{P_x^2 + P_y^2} \\ &= \sqrt{(p_x \cdot FG)^2 + (p_y \cdot EG)^2} \\ &= EF \sqrt{p_x^2 \cos^2 \theta + p_y^2 \sin^2 \theta} \\ p &= \sqrt{p_x^2 \cos^2 \theta + p_y^2 \sin^2 \theta} = \sqrt{p_n^2 + p_t^2} \quad \dots \quad (3) \end{aligned}$$

and since the component forces in directions OX and OY on unit area of the plane EF are  $p_x \cos \theta$  and  $p_y \sin \theta$ ,  $p$  evidently makes an angle  $\alpha$  with OX such that

$$\tan \alpha = \frac{p_y \sin \theta}{p_x \cos \theta} = \frac{p_y}{p_x} \cdot \tan \theta \quad \dots \quad (4)$$

And  $p$  makes an angle  $\beta$  with the plane EF, across which it acts, such that

$$\tan \beta = \frac{p_n}{p_t} \text{ or } \frac{p_x \cos^2 \theta + p_y \sin^2 \theta}{(p_x - p_y) \cos \theta \sin \theta} = \cot \phi \quad \dots \quad (5)$$

where  $\phi$  is the angle which the resultant stress makes with the normal to the plane EF.

EXAMPLE.—Find the plane across which the resultant stress is most inclined to the normal.

Let  $\phi$  be the maximum inclination to the normal. Then

$$\tan \phi = \frac{p_t}{p_n} = \frac{(p_x - p_y) \cos \theta \sin \theta}{p_x \cos^2 \theta + p_y \sin^2 \theta} \quad \dots \quad (a)$$

When  $\phi$  is a maximum,  $\tan \phi$  is a maximum, and

$$\frac{d(\tan \phi)}{d\theta} = 0$$

Therefore, differentiating and dividing out common factors,

$$(p_x \cos^2 \theta + p_y \sin^2 \theta) \cos 2\theta + (p_x - p_y) \sin \theta \cos \theta \times \sin 2\theta = 0$$

$$p_n \cos 2\theta + p_t \sin 2\theta = 0$$

$$\tan 2\theta = -\frac{p_n}{p_t} = -\cot \phi = \tan \left( \frac{\pi}{2} + \phi \right)$$

$$2\theta = \frac{\pi}{2} + \phi$$

$$\theta = \frac{\pi}{4} + \frac{\phi}{2} \quad \dots \quad (b)$$

Substituting this value of  $\theta$  in equation (a) we get—

$$\tan \phi = \frac{(p_x - p_y) \cos \phi}{p_x(1 - \sin \phi) + p_y(1 + \sin \phi)}$$

hence

$$\frac{p_y}{p_x} = \frac{1 - \sin \phi}{1 + \sin \phi}$$

or

$$\sin \phi = \frac{p_x - p_y}{p_x + p_y} \quad \dots \quad (c)$$

Equation (c) gives the maximum inclination to the normal, and equation (b) gives the inclination of the normal to the axis of the direct stress  $p_x$ .

*Unlike Stresses.*—If the two given stresses  $p_x$  and  $p_y$  are unlike, say  $p_x$  tensile and  $p_y$  compressive, we have the slight modifications—

$$p_n = p_x \cos^2 \theta - p_y \sin^2 \theta \text{ (tensile)}$$

$$p_t = (p_x + p_y) \sin \theta \cos \theta = \frac{1}{2}(p_x + p_y) \sin 2\theta$$

These results might be obtained just as before, but using Fig. 15. The maximum shear is still when  $\theta = 45^\circ$ , and its value is—

$$\frac{p_x + p_y}{2}$$

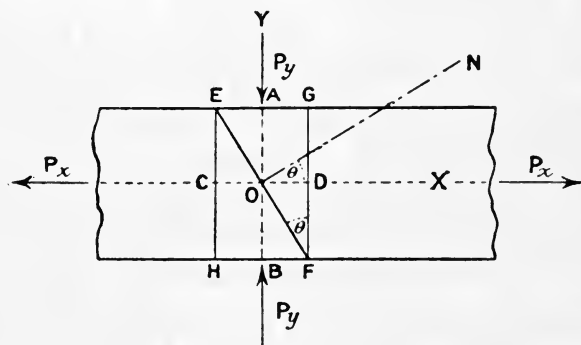

FIG. 15.

In the special case of unlike stresses, where  $p_x$  and  $p_y$  are numerically equal, the values for  $\theta = 45^\circ$  are—

$$p_t = \frac{p_x + p_y}{2} = p_x = p_y$$

$$p_n = 0$$

These correspond exactly with the case of pure shear in Art. 8.

**16. Ellipse of Stress.**—In the last article we supposed two principal stresses  $p_x$  and  $p_y$  given, and the third to be zero, *i.e.* no stress perpendicular to Figs. 14 and 15. In this case using the same notation and like stresses, the direction and magnitude of the resultant stress on any plane can easily be found graphically by the following means.

Describe, with O as centre (Fig. 16), two circles, CQD and ARB, their radii being proportional to  $p_x$  and  $p_y$  respectively. Draw OQ normal to the interface EF (Art. 15) to meet the larger circle in Q and the smaller in R. Draw QN perpendicular to OX and RP perpendicular to OY to meet QN in P. Then OP represents the resultant stress  $p$  both in magnitude of intensity and in direction. The locus of P for various values of  $\theta$ , *i.e.* for different oblique interfaces, is evidently an ellipse, for the co-ordinate ON along OX is—

$$OQ \cos \theta \text{ or } p_x \cos \theta$$

and PN, the co-ordinate along OY, is—

$$OR \sin \theta \text{ or } p_y \sin \theta$$

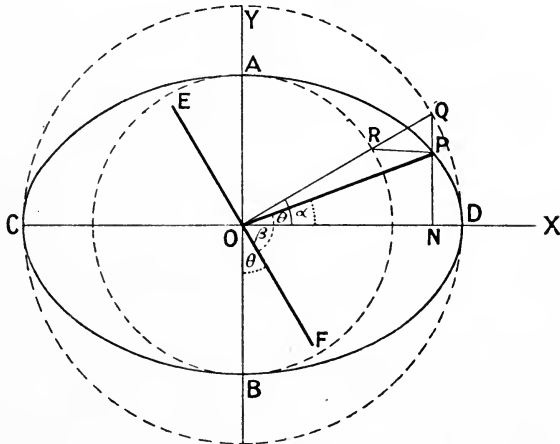

FIG. 16.—Ellipse of stress.

The axes of the ellipse are the axes of stress (Art. 14).

Also that 
$$\tan \alpha = \frac{p_y \sin \theta}{p_x \cos \theta} = \frac{p_y}{p_x} \tan \theta$$

is obvious from the figure.

In the second case where, say,  $p_y$  is negative and  $p_x$  is positive,  $OP'$

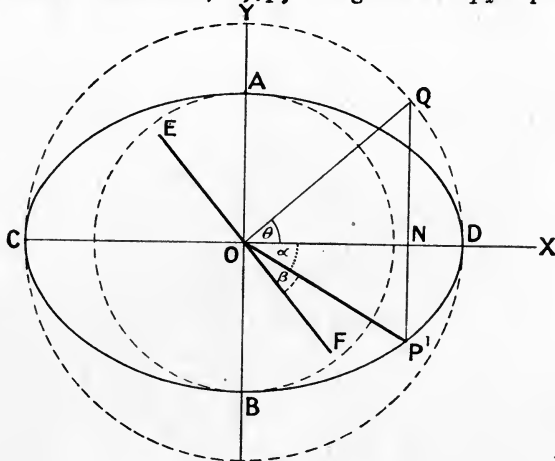

FIG. 17.

(Fig. 17) will represent the stress in magnitude and direction: here  $\tan \alpha$  is negative and  $\beta$  is obviously less than  $\beta$  in Fig. 16.

In the particular case where  $p_x$  and  $p_y$  are equal in magnitude, the ellipse is a circle (e.g. see Art. 121).

EXAMPLE.—A piece of material is subjected to tensile stresses of 6 tons per square inch, and 3 tons per square inch, at right angles to each other. Find fully the stresses on a plane, the normal of which makes an angle of  $30^\circ$  with the 6-ton stress.

The intensity of normal stress on such a plane is—

$$\begin{aligned} p_n &= 6 \cos^2 30^\circ + 3 \sin^2 30^\circ \\ &= 6 \times \frac{3}{4} + 3 \times \frac{1}{4} = 4\frac{1}{2} + \frac{3}{4} = 5\frac{1}{4} \text{ tons per square inch} \end{aligned}$$

And the intensity of tangential stress is—

$$\begin{aligned} p_t &= 6 \sin 30^\circ \cos 30^\circ - 3 \sin 30^\circ \cos 30^\circ \\ &= 3 \times \frac{1}{2} \times \frac{\sqrt{3}}{2} = \frac{3\sqrt{3}}{4} = 1.299 \text{ tons per square inch} \end{aligned}$$

The resultant stress then has an intensity,

$$p = \sqrt{\left(\frac{21}{4}\right)^2 + \left(\frac{3\sqrt{3}}{4}\right)^2} = \frac{1}{4} \sqrt{441 + 27} = \frac{10.82}{2} = 5.41 \text{ tons per sq. in.}$$

and makes an angle  $\alpha$  with the direction of the 6-ton stress, such that

$$\tan \alpha = \frac{3 \sin 30^\circ}{6 \cos 30^\circ} = \frac{1}{2} \tan 30^\circ = 0.288$$

which is the tangent of  $16^\circ 4'$ .

This is the angle which the resultant stress makes with the 6-ton stress. It makes, with the normal to the plane across which it acts, an angle

$$30^\circ - 16^\circ 4' = 13^\circ 56'$$

To check this, the cotangent of the angle the resultant stress makes with the normal, or the tangent of that it makes with the plane, is—

$$\frac{p_n}{p_t} = \frac{5.25}{1.299} = 4.035$$

which is tangent of  $76^\circ 4'$ , and therefore the cotangent of  $13^\circ 56'$ .

**17. Principal Stresses.**—When bodies are subjected to known stresses in certain directions, and these are not all wholly normal stresses, the stresses on various planes may be found by the methods of the two previous articles provided we first find the principal planes and principal stresses (see Art. 14). It is also often important in itself, in such cases, to find the principal stresses, as one of these is, as previously stated, the greatest stress to which the material is subjected. We proceed to find principal stresses and planes in a few simple, two-dimensional cases where the stress perpendicular to the figure is *nil*.

As a very simple example, we have found in Art. 8 that the two shear stresses of equal intensity, on two mutually perpendicular planes, with no stress on planes perpendicular to the other two, give principal

stresses of intensity equal to that of the shear stresses, on planes inclined  $\frac{\pi}{4}$  to the two perpendicular planes to which the pure shear stresses are tangential.

As a second example, let there be, on mutually perpendicular planes, normal stresses, one of intensity  $p_1$  and the other of intensity  $p_2$ , in addition to the two equal shear stresses of intensity  $q$ , as in Fig. 18, which represents a rectangular block of the material unit thickness perpendicular to the plane of the figure, across all planes parallel to which there is no stress; we may imagine the block so small that the variation of stress intensity over any plane section is negligible. The stresses  $p_1$ ,  $p_2$ , and  $q$  may be looked upon as independent known stresses arising from several different kinds of external straining actions, or as rectangular

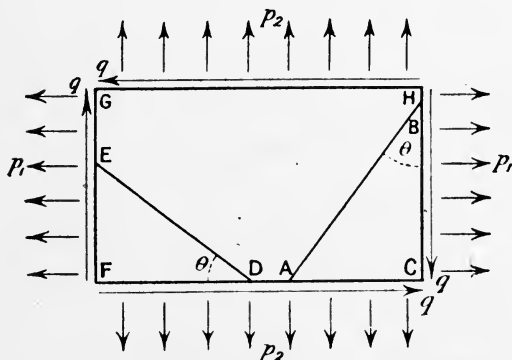

FIG. 18.

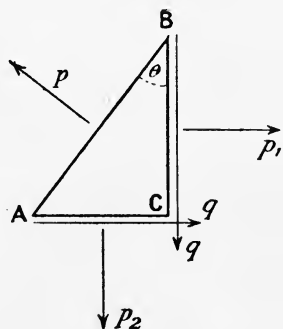

FIG. 19.

components, normal and tangential (Art. 7), into which oblique stresses, on the faces perpendicular to the figure, have been resolved.

It is required to know the direction of the principal planes and the intensity of the (normal) principal stresses upon them. Fig. 18 represents the given normal stresses as tensions: the work is practically the same in the case of compressive stresses, or if one stress be compressive and the other tensile.

Let  $\theta$  be the inclination of one principal plane to the face BC. Then an interface, AB, is a principal plane, and the stress  $p$  upon it is wholly normal to AB. Consider the equilibrium of a wedge, ABC (Figs. 18 and 19), cut off by such a plane.

Resolving forces parallel to AC—

$$\begin{aligned}
 p \cdot AB \times \cos \theta &= p_1 \cdot BC + q \cdot AC \\
 &= p_1 \cdot AB \cos \theta + q \cdot AB \sin \theta
 \end{aligned}$$

hence

$$(p - p_1) \cos \theta = q \sin \theta$$

$$p - p_1 = q \tan \theta \dots \dots \dots (1)$$



Resolving parallel to BC—

$$\begin{aligned} p \cdot AB \times \sin \theta &= p_2 \cdot AC + q \cdot BC \\ &= p_2 \cdot AB \sin \theta + qAB \cos \theta \\ (p - p_2) \sin \theta &= q \cos \theta \\ p - p_2 &= q \cot \theta \dots \dots \dots (2) \end{aligned}$$

Subtracting equation (1) from equation (2)—

$$\begin{aligned} p_1 - p_2 &= q(\cot \theta - \tan \theta) = \frac{2q}{\tan 2\theta} \\ \tan 2\theta &= \frac{2q}{p_1 - p_2} \dots \dots \dots (3) \end{aligned}$$

From which two values of  $\theta$  differing by a right angle may be found, *i.e.* the inclinations to BC of two principal planes which are mutually perpendicular.

Further, multiplying (1) by (2)—

$$\begin{aligned} (p - p_1)(p - p_2) &= q^2 \dots \dots \dots (4) \\ p^2 - p(p_1 + p_2) - (q^2 - p_1 p_2) &= 0 \\ p &= \frac{1}{2}(p_1 + p_2) \pm \sqrt{\frac{1}{4}(p_1 + p_2)^2 + (q^2 - p_1 p_2)} \quad (5) \end{aligned}$$

or,

$$\frac{1}{2}(p_1 + p_2) \pm \sqrt{\frac{1}{4}(p_1 - p_2)^2 + q^2}$$

These two values of  $p$  are the values of the (normal) stress intensities on the two principal planes. The larger value (where the upper sign is taken) will be the stress intensity on such a plane as AB (Figs. 18 and 19), and will be of the same sign as  $p_1$  and  $p_2$ ; the smaller value, say  $p'$ , will be that on such a plane as ED (Figs. 18 and 20) perpendicular to AB, and will be of opposite sign to  $p_1$  and  $p_2$  if  $q^2$  is greater than  $p_1 p_2$ .

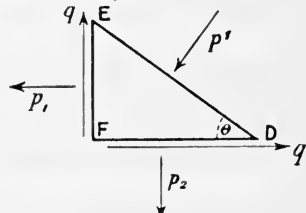

FIG. 20.

The planes on which there are maximum shear stresses are inclined  $45^\circ$  to the principal planes found, and the maximum intensity of shear stress is (Art. 15)—

$$\frac{p - p'}{2} = \sqrt{\frac{1}{4}(p_1 + p_2)^2 + q^2 - p_1 p_2} = \sqrt{\frac{1}{4}(p_1 - p_2)^2 + q^2}$$

The modifications necessary in (3) and (4), if  $p_1$  or  $p_2$  is of negative sign, are obvious. If, say,  $p_2$  is zero, the results from substituting this value in (3) and (4) are simple. This special case is of sufficient importance to be worth setting out briefly by itself in the next article instead of deducing from the more general case.

**18. Principal Planes and Stresses when complementary shear stresses are accompanied by a normal stress on the plane of one shear stress.**—Fig. 21 shows the forces on a rectangular block, GHCF, of unit thickness perpendicular to the figure, and of indefinitely small dimensions parallel to the figure, unless the stresses are uniform. Let  $\theta$  be the inclination of a principal plane AB to the plane BC, which

has normal stress of intensity  $p_1$  and a shear stress of intensity  $q$  acting on it, and let  $p$  be the intensity of the wholly normal stress on AB.

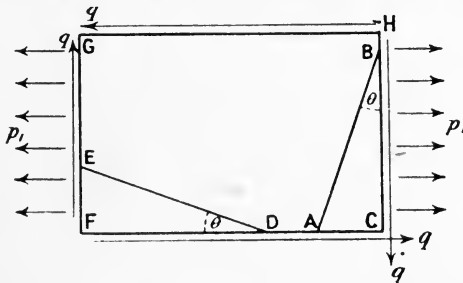

FIG. 21.

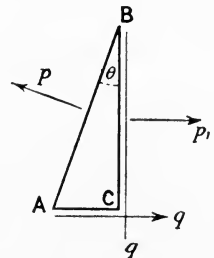

FIG. 22.

The face FC has only the shear stress of intensity  $q$  acting tangential to it.

Consider the equilibrium of the wedge ABC; resolving the forces parallel to AC (Figs. 21 and 22)—

$$\begin{aligned}
 p \cdot AB \times \cos \theta &= p_1 \cdot BC + q \cdot AC \\
 &= p_1 AB \cos \theta + q \cdot AB \sin \theta \\
 (p - p_1) \cos \theta &= q \sin \theta \\
 (p - p_1) &= q \tan \theta \dots \dots \dots (1)
 \end{aligned}$$

Resolving parallel to BC—

$$\begin{aligned}
 p \cdot AB \cdot \sin \theta &= q \cdot BC = q \cdot AB \cos \theta \\
 \tan \theta &= \frac{q}{p} \dots \dots \dots (2)
 \end{aligned}$$

Substituting for  $\tan \theta$  in (1)—

$$\begin{aligned}
 (p - p_1) &= \frac{q^2}{p} \\
 p^2 - p_1 p - q^2 &= 0 \\
 p &= \frac{1}{2} p_1 \pm \sqrt{\frac{1}{4} p_1^2 + q^2} \dots \dots \dots (3)
 \end{aligned}$$

and the values of  $\theta$  may be found by substituting these values of  $p$  in (2). The two values differ by a right angle, the principal planes being at right angles. AB (Fig. 22) shows a principal plane of greatest stress corresponding to—

$$p = \frac{1}{2} p_1 + \sqrt{\frac{1}{4} p_1^2 + q^2}$$

and ED (Fig. 23) shows the other principal plane on which the normal stress is—

$$p' = \frac{1}{2} p_1 - \sqrt{\frac{1}{4} p_1^2 + q^2}$$

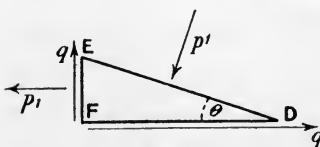

FIG. 23.

of opposite sign to  $p_1$ .

The planes of greatest shear stress

are (Art. 15) those inclined  $45^\circ$  to the principal planes, and the intensity of shear stress upon them is—

$$\frac{p - p'}{2} = \sqrt{\frac{1}{4}p_1^2 + q^2} \quad . . . . . (4)$$

If from a point in a material under compound stress we trace out (in, say, a plane across which there is no stress, as in Figs. 18 to 23) a locus to which the axis of principal stress, for points in the locus, is always tangential, a curve of principal stress is obtained: the curve cuts another series of planes of principal stress for points in itself at right angles (see Fig. 105). Such a *line of stress* is usually curved, since the normal and tangential stresses on parallel planes usually vary differently from point to point in any fixed direction. In other words, from any point to a neighbouring one the principal stresses generally vary in intensity and direction.

EXAMPLE.—At a point in material under stress the intensity of the resultant stress on a certain plane is 4 tons per square inch (tensile) inclined  $30^\circ$  to the normal of that plane. The stress on a plane at right angles to this has a normal tensile component of intensity  $2\frac{1}{2}$  tons per square inch. Find fully (1) the resultant stress on the second plane, (2) the principal planes and stresses.

(1) On the first plane the tangential stress is—

$$q = 4 \sin 30^\circ = 2 \text{ tons per square inch}$$

Hence on the second plane the tangential stress is 2 tons per square inch (Art. 8). And the resultant stress is—

$$p = \sqrt{2\cdot5^2 + 2^2} = \frac{1}{2}\sqrt{41} = 3\cdot2 \text{ tons per square inch}$$

(2) The intensity of stress normal to the first plane is—

$$4 \cos 30^\circ = 3\cdot464 \text{ tons per square inch}$$

Hence the principal stresses are (Art. 17 (5))—

$$\begin{aligned} p &= \frac{3\cdot464 + 2\cdot5}{2} \pm \sqrt{\frac{1}{4}(3\cdot462 - 2\cdot5)^2 + 2^2} \\ &= 2\cdot982 \pm \sqrt{0\cdot23 + 4} \\ &= 2\cdot982 \pm 2\cdot06 \\ &= 5\cdot042 \text{ tons per square inch tension and } 0\cdot922 \text{ tons} \\ &\quad \text{per square inch tension} \end{aligned}$$

If  $\theta$  be the angle made by a principal plane with the first-mentioned plane, by Art. 17 (3),

$$\begin{aligned} \tan 2\theta &= \frac{2 \times 2}{3\cdot464 - 2\cdot5} = \frac{4}{0\cdot964} = 4\cdot149 \\ 2\theta &= 76^\circ 27' \\ \theta &= 38^\circ 13\cdot5' \end{aligned}$$

The principal planes and stresses are then one plane inclined  $38^\circ 13\cdot5'$  to the first given plane, and having a tensile stress 5·042 tons per square inch across it, and a second at right angles to the other

or inclined  $51^{\circ} 46' 5''$  to the first given plane, and having a tensile stress  $0.922$  tons per square inch across it. The planes are shown in Fig. 24.

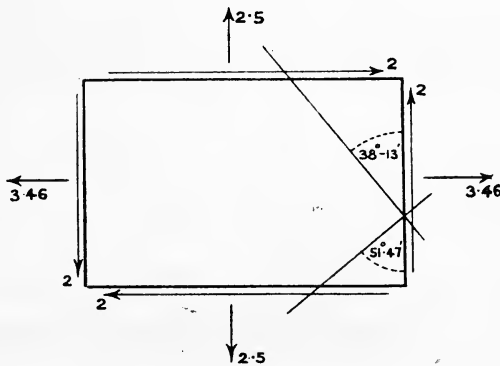

FIG. 24.

19. **Principal Strains.**—In a bar of material within limits of perfect elasticity a (say tensile) stress intensity  $p_1$  alone will produce a strain  $e_1$ , in its own direction such that—

$$e_1 = \frac{p_1}{E}$$

where  $E$  is Young's modulus of elasticity or the stretch modulus, provided there is freedom of lateral contraction. The contraction in all directions at right angles to the axis of the stress  $p_1$  will be represented by a strain—

$$\frac{p_1}{mE}$$

where  $\frac{1}{m}$  is Poisson's ratio.

In an isotropic material, *i.e.* one having the same elastic properties in all directions, the effect of a stress  $p_2$  acting alone at right angles to the direction of  $p_1$  would be to produce a strain in its own direction,  $e_2$ , such that—

$$e_2 = \frac{p_2}{E}$$

and at right angles to this, including the direction of the strain  $\frac{p_1}{E}$ , a contraction strain—

$$\frac{p_2}{mE}$$

Similarly a stress  $p_3$ , the direction of which is perpendicular to both the previously mentioned stresses, will produce in addition to its longitudinal strain a contraction strain—

$$\frac{p_3}{mE}$$

in all directions perpendicular to its direction, including the direction of the stress  $p_1$ .

If we have at a point in isotropic material three principal stresses of intensities  $p_1$ ,  $p_2$ , and  $p_3$ , each will independently produce the same strains which it would cause if acting alone. Taking all the stresses of the same sign the total strain produced in the direction of the stress  $p_1$  will then be—

$$e_1 = \frac{p_1}{E} - \frac{p_2 + p_3}{mE} \dots \dots \dots (1)$$

In the direction of  $p_2$  the strain

$$e_2 = \frac{p_2}{E} - \frac{p_1 + p_3}{mE} \dots \dots \dots (2)$$

and in direction of  $p_3$  the strain

$$e_3 = \frac{p_3}{E} - \frac{p_1 + p_2}{mE} \dots \dots \dots (3)$$

If any one of the above stresses is of opposite kind, *i.e.* compressive in this case, the strains will be found by changing the sign of that stress in each of the above equations.

**20. Ellipsoid of Strain.**—Using the symbols of the last article, at a point where the principal stresses are  $p_1$ ,  $p_2$ , and  $p_3$ , the strains in directions other than these may be represented in the following manner.

Imagine a sphere centred at the point, and then each of three mutually perpendicular diameters in the directions of the three principal stresses, strained in the manner indicated by the equations (1), (2), and (3) (Art. 19); further, that every line parallel to the direction of  $p_1$  receives the strain  $e_1$ , every line parallel to  $p_2$  is strained by an amount  $e_2$ , and all lines parallel to  $p_3$  are strained by an amount  $e_3$ . The sphere will now have become an ellipsoid, and every radius vector drawn from the centre terminated by the surface of the ellipsoid will represent the length of the corresponding radius in the sphere.

**21. Modified Elastic Constants.**—Young's modulus was defined (Art. 9) by the relation

$$E = \frac{p_1}{e_1}$$

where  $e_1$  is the strain produced by a tensile stress of intensity  $p_1$ , no other stress acting with it. The action of other independent principal stresses would alter the strain produced, and so the constant defined by the relation

$$\text{modulus} = \frac{p_1}{e_1}$$

would not be the ordinary stretch modulus, but a modification of it. Varying circumstances would give different values of the modulus.

**EXAMPLE I.**—If a bar be stretched in such a manner that all lateral strain is prevented, what is the value of the modulus?

Under the given conditions, the equations of Art. 19 become—

$$(1) \dots \dots \dots e_1 = \frac{p_1}{E} - \frac{p_2 + p_3}{mE}$$

$$(2) \dots \dots \dots e_2 = 0 = \frac{p_2}{E} - \frac{p_1 + p_3}{mE}$$

$$(3) \dots \dots \dots e_3 = 0 = \frac{p_3}{E} - \frac{p_1 + p_2}{mE}$$

Evidently

$$p_2 = p_3$$

and from (2)

$$\frac{p_2}{E} = \frac{p_1 + p_2}{mE}$$

or,

$$p_2 \left(1 - \frac{1}{m}\right) = \frac{p_1}{m} \quad \text{or} \quad p_2 = \frac{p_1}{m - 1}$$

and from (1)

$$e_1 = \frac{1}{E} \left( p_1 - \frac{2}{m} p_2 \right) = \frac{p_1}{E} \left( 1 - \frac{2}{m} \cdot \frac{1}{m - 1} \right)$$

$$e_1 = \frac{p_1 (m - 2)(m + 1)}{E m(m - 1)}$$

$$p_1 = e_1 \times E \frac{m(m - 1)}{(m - 2)(m + 1)}$$

the modulus being here modified to  $\frac{m(m - 1)}{(m - 2)(m + 1)}$  times that for simple stretching with free lateral contraction. If  $m = 4$  the modified modulus will be  $1.2E$ , or in other words, the force required to produce a given longitudinal strain, when lateral strain is prevented, is 20 per cent. greater than when the material has free lateral movement.

EXAMPLE 2.—The intensities of the three principal stresses in a boiler-plate are at a certain point 4 tons per square inch tensile in one direction, 3 tons per square inch tensile in a second, and zero in a third. Find what stress acting alone would produce the same strain in the direction of the 4-ton stress, given the ratio of Young's modulus to the modulus of rigidity is  $\frac{5}{2}$ .

By Art. 13 (1)

$$\begin{aligned} \frac{1}{m} &= \frac{E}{2N} - 1 \\ &= \frac{5}{4} - 1 = \frac{1}{4} \end{aligned}$$

Hence, in the direction of the 4-ton stress,

$$\text{Strain} = \frac{4}{E} - \frac{1 \cdot 3}{4E} = \frac{13}{4} \times \frac{1}{E}$$

If  $p$  is the stress intensity to produce this strain when acting alone

$$\frac{p}{E} = \frac{13}{4} \cdot \frac{1}{E}$$

or,

$$p = \frac{13}{4} = 3\frac{1}{4} \text{ tons per square inch}$$

## EXAMPLES I.

1. A round tie-bar of mild steel, 18 feet long and  $1\frac{1}{8}$  inch diameter, lengthens  $\frac{1}{16}$  inch under a pull of 7 tons. Find the intensity of tensile stress in the bar, the value of the stretch modulus, and the greatest intensity of shear stress on any oblique section.

2. A rod of steel is subjected to a tension of 3 tons per square inch of cross-section. The shear stress across a plane oblique to the axis is 1 ton per square inch. What is the inclination of the normal of this plane to the axis? What is the intensity of the normal stress across the plane, and what is the intensity of the resultant stress across it? Of the two possible solutions, take the plane with normal least inclined to the axis of the rod.

3. On a plane oblique to the axis of the bar in question 1, the intensity of shear stress is 1.5 ton per square inch. What is the intensity of normal stress across this plane? Also what is the intensity of resultant stress across it? Take the plane most inclined to the axis.

4. A hollow cylindrical cast-iron column is 10 inches external and 8 inches internal diameter and 10 feet long. How much will it shorten under a load of 60 tons? Take  $E$  as 8000 tons per square inch.

5. The stretch modulus of elasticity for a specimen of steel is found to be 28,500,000 lbs. per square inch, and the transverse modulus is 11,000,000 lbs. per square inch. What is the modulus of elasticity of bulk for this material, and how many times greater is the longitudinal strain caused by a pull than the accompanying lateral strain?

6. The tensile (principal) stresses at a point within a boiler-plate across the three principal planes are 0, 2, and 4 tons per square inch. Find the component normal and tangential stress intensities, and the intensity and direction of the resultant stress, at this point, across a plane perpendicular to the first principal plane, and inclined  $30^\circ$  to the plane having a 4-ton principal stress.

7. With the same data as question 6, find the inclination of the normal, to the axis of the 4-ton stress, of a plane on which the resultant stress is inclined  $15^\circ$  to the normal. What is the intensity of this resultant stress?

8. At a point in strained material the principal stresses are 0, 5 tons per square inch tensile, and 3 tons per square inch compressive. Find the resultant stress in intensity and direction on a plane inclined  $60^\circ$  to the axis of the 5-ton stress, and perpendicular to the plane which has no stress. What is the maximum intensity of shear stress in the material?

9. If a material is so strained that at a certain point the intensities of normal stress across two planes at right angles are 5 tons and 3 tons per square inch, both tensile, and if the shear stress across these planes is 4 tons per square inch, find the maximum direct stress and the plane to which it is normal.

10. Solve question 9 if the stress of 3 tons per square inch is compressive.

11. At a point in a cross-section of a girder there is a tensile stress of 4 tons per square inch normal to the cross-section; there is also a shear stress of 2 tons per square inch on that section. Find the principal planes and stresses.

12. In a shaft there is at a certain point a shear stress of 3 tons per square inch in the plane of a cross-section, and a tensile stress of 2 tons per square inch normal to this plane. Find the greatest intensities of direct stress and of shear stress.

13. In a boiler-plate the tensile stress in the direction of the axis of the shell is  $2\frac{1}{2}$  tons per square inch, and perpendicular to a plane through the axis the tensile stress is 5 tons per square inch. Find what intensity of

tensile stress acting alone would produce the same maximum tensile strain if Poisson's ratio is  $\frac{1}{4}$ .

14. A cylindrical piece of metal undergoes compression in the direction of its axis. A well-fitted metal casing, extending almost the whole length, reduces the lateral expansion by half the amount it would otherwise be. Find in terms of " $m$ " the ratio of the axial strain to that in a cylinder quite free to expand in diameter. (Poisson's ratio =  $\frac{1}{m}$ .)

15. Find the ratio between Young's modulus for compression and the modified modulus when lateral expansion in one direction is entirely prevented. Take Poisson's ratio as  $\frac{1}{m}$ .

16. If within the elastic limit a bar of steel stretches  $\frac{1}{1000}$  of its length under simple tension, find the proportional change in volume, Poisson's ratio being  $\frac{1}{4}$ .

17. Three long parallel wires, equal in length and in the same vertical plane, jointly support a load of 3000 lbs. The middle wire is steel, and the two outer ones are brass, and each is  $\frac{1}{4}$  square inch in section. After the wires have been so adjusted as to each carry  $\frac{1}{3}$  of the load a further load of 7000 lbs. is added. Find the stress in each wire, and the fraction of the whole load carried by the steel wire.  $E$  for steel  $30 \times 10^6$  lbs. per square inch, and for brass  $12 \times 10^6$  lbs. per square inch.



## CHAPTER II.

### MECHANICAL PROPERTIES OF METALS.

**22. Elasticity.**—A material is said to be perfectly elastic if the whole of the strain produced by a stress disappears when the stress is removed. Within certain limits (Art. 5) many materials exhibit practically perfect elasticity.

*Plasticity.*—A material may be said to be *perfectly* plastic when no strain disappears when it is relieved from stress.

In a plastic state, a solid shows the phenomenon of “flow” under unequal stresses in different directions, much in the same way as a liquid. This property of “flowing” is utilized in the “squirting” of lead pipe, the drawing of wire, the stamping of coins, forging, etc.

*Ductility* is that property of a material which allows of its being drawn out by tension to a smaller section, as for example when a wire is made by drawing out metal through a hole. During ductile extension, a material generally shows a certain degree of elasticity, together with a considerable amount of plasticity. *Brittleness* is lack of ductility.

When a material can be beaten or rolled into plates, it is said to be malleable; malleability is a very similar property to ductility.

**23. Tensile Strain of Ductile Metals.**—If a ductile metal be subjected to a gradually increasing tension, it is found that the resulting strains, both longitudinal and lateral, increase at first proportionally to the stress. When the elastic limit is reached, the tensile strain begins to increase more quickly, and continues to grow at an increasing rate as the load is augmented. At a stress a little greater than the elastic limit some metals, notably soft irons and steels, show a marked breakdown, the elongation becoming many times greater than previously with little or no increase of stress. The stress at which this sudden stretch occurs is called the “yield point” of the material.

Fig. 25 is a “stress-strain” curve for a round steel bar 10 inches long and 1 inch diameter, of which the ordinates represent the stress intensities and the abscissæ the corresponding strains. The limit of elasticity occurs about A, the line OA being straight. The point B marks the “yield point,” AB being slightly curved. After the yield-point stress is reached, the ductile extensions take place, the strains increasing at an accelerating rate with greater stresses as indicated by the portion of the curve between C and D. Strains produced at loads above the yield point do not develop in the same way as those below the elastic limit. The greater part of the strain occurs very quickly,

but this is followed without any further loading by a small additional extension which increases with time but at a diminishing rate. The

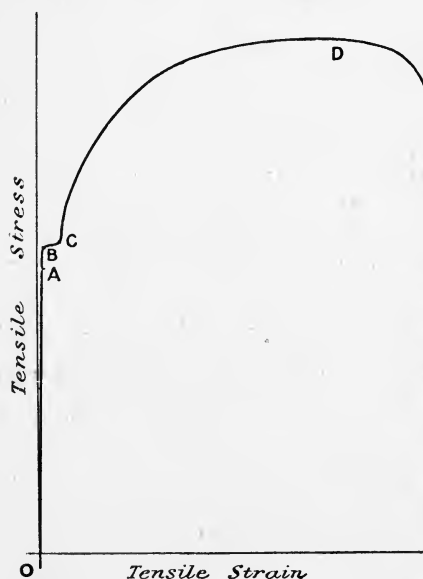

FIG. 25.

phenomenon of the slow growth of a strain under a steady tensile stress has been called "creeping" by Prof. Ewing. On account of the part which takes time to develop, the total amount of strain produced by a given load and the shape of the stress-strain curve will be slightly modified by the rate of loading. At D, just before the greatest load is reached, the material is almost perfectly plastic, the tensile strain increasing greatly for very slight increase of load. It should be noted that in this diagram both stress intensity and strain are reckoned on the original dimensions of the material.

During the ductile elongation, the area of cross-section decreases in practically the same proportion that the length

increases, or in other words, the volume of the material remains practically unchanged. The reduction in area of section is generally fairly uniform along the bar. After the maximum load is reached, a sudden local stretching takes place, extending over a short length of the bar and forming a "waist." The local reduction in area is such that the load necessary to break the bar at the waist is considerably less than the maximum load on the bar before the local extension takes place. Nevertheless the breaking load divided by the reduced area of section shows that the "actual stress intensity" is greater than at any previous load. If the load be divided by the original area of cross-section, the result is the "nominal intensity of stress," which is less, in such a ductile material as soft steel, at the breaking load than at the maximum load sustained at the point D on Fig. 25. Fig. 31 shows the stress-strain curves for samples of other materials in tension; each curve refers to specimens 1 inch round diameter, and 8 inches long. The elastic portions of the curves are drawn separately, with the strain scale 250 times as great as that for the more plastic strains.

**24. Elastic Limit and Yield Point.**—The elastic limit (Art. 5) in tension is the greatest stress after which no permanent elongation remains when all stress is removed. In nearly all metals, and particularly in soft and ductile ones, instruments of great precision (see Art. 174) will reveal slight permanent extensions resulting from very

low stresses, and particularly in material which has never before been subjected to such tensile stress. In many metals, however, notably wrought iron and steel, if we neglect permanent extensions less than, say,  $\frac{1}{100000}$  of the length of a test-bar (*i.e.* strains less than 0.00001), stresses up to a considerable proportion of the maximum cause purely elastic and proportional elongations. The proportionality of the strain to the stress in Fig. 25 is indicated by OA being a straight line. For such metals as wrought iron and steel, the proportionality holds good up to the elastic limit—that is, the end of the straight line at A indicates the elastic limit, or in other words, Hooke's Law (Art. 5) is substantially true. This is not equally true for all metals; in the case of rolled aluminium slowly and continuously loaded, at very low stresses the strains increase faster than the stresses, and yet practically all the strain disappears after the removal of the stress; hence the elastic limit cannot be found from an inspection of the "stress-strain" diagram.

*Commercial Elastic Limit.*—In commercial tests of metals exhibiting a yield point, the stress at which this marked breakdown occurs is often called the elastic limit; it is generally a little above the true elastic limit.

There are, then, three noticeable limits of stress.

- (1) The elastic limit, as defined in Art. 5.
- (2) The limit of proportionality of stress to strain.
- (3) The stress at yield point—the commercial elastic limit.

In wrought iron and steel the first two are practically the same, and the third is somewhat higher.

The suggestion has been made that failure of perfect elasticity just below the yield point is due to small portions of the material reaching the breaking-down point before the general mass of the material. This supposition is supported by the fact that ductile materials of very uniform character show the yield point more strikingly than inferior specimens of the same material.

When the necessary stress is applied, the yielding certainly does not take place simultaneously throughout the mass, but begins locally at one or more points (probably due to a slight concentration of stress), and spreads through the remaining material without further increase of the load. This spreading of the condition of breakdown may be watched in unmachined iron and steel; the strain in the material is too great to be taken up by the skin of oxide, which cracks and flies off in minute pieces as the yielding spreads. In highly finished drawn steel the oxide chips off so as to form interesting markings on the surface of the bar; two systems of parallel curves, equally and oppositely inclined to the axis of the bar, are formed. A similar phenomenon may be noticed on a polished metallic surface when the metal is strained beyond the elastic limit. The inclined curves are called Lüders' lines, from the fact that Lüders first called attention to them. They appear to indicate elastic failure by shearing.

*Microscopic Observations. Metallography.*—The study of the structure of metals as revealed by the microscope has received much attention in recent years, and has led to various interesting discoveries. The

general subject now known as Metallography is outside the scope of this book,<sup>1</sup> but the effect of strain on the structure must be mentioned.

Microscopic observation shows metals to consist of an aggregation of crystalline grains separated by films or membranes of material of different composition. Evidently the mechanical properties will be influenced by such films, and strain or fracture may take place along the film due to brittleness or want of continuity, or by actual fracture of the crystalline grains along their planes of cleavage or greatest weakness.

Ewing and Rosenhain<sup>2</sup> found, by microscopically examining a specimen of metal under gradually increasing strain, that beyond the yield point lines appeared on some of the crystals, and increased in number as the strain increased. These lines, which they called slip bands or slip lines, they attributed to steps formed on the surface, due to slips along the cleavage planes of the crystal. Thus a surface, ACB (Fig. 26), when pulled in the direction of the arrows, would develop the shape shown in Fig. 27 by slips along the cleavage planes at



FIG. 26.

(From Mellor's "Crystallization of Iron and Steel.")

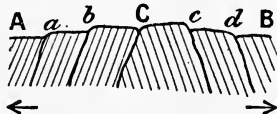

FIG. 27.

*a*, *b*, *c*, and *d*, C being the junction of two contiguous grains. During plastic strain, according to their view, slipping along the planes of cleavage of the crystals continues, and finally the slips develop into cracks and fracture takes place, not generally at the boundaries, but through the crystal grains themselves, the crystalline structure being preserved during all stages of strain.

. 25. **Ultimate and Elastic Strength and Factor of Safety.**—The maximum load necessary to rupture a specimen in simple tension or shear, divided by the *original area* of section at the place of fracture, gives the nominal maximum stress necessary for fracture, and is called the ultimate strength of the material under that particular kind of stress. It is usually reckoned in pounds or tons per square inch. The ultimate strength in tension is also called the *Tenacity*. The greatest calculated stress to which a part of a machine or structure is ever subjected is called the working stress, and the ratio—

$$\frac{\text{ultimate strength}}{\text{working stress}}$$

is called the Factor of Safety.

It is, of course, usual to ensure that the working stress shall be below the elastic limit of the material; but this is not sufficient, and designers, when allowing a given working stress, specify or assume,

<sup>1</sup> A brief and interesting account of the "Crystallization of Iron and Steel" for engineering students has been written by Dr. J. W. Mellor. (Longmans.)

<sup>2</sup> *Phil. Trans. Roy. Soc.*, 1899.

amongst other properties, an ultimate strength for the material, greater than the working stress in the ratio of a reasonable factor of safety. The factor of safety varies very greatly according to the nature of the stresses, whether constant, variable or alternating, simple or compound. It is frequently made to cover an allowance for straining actions, such as shocks, no reliable estimate of which can in some instances be made, diminution of section by corrosion, and other contingencies.

*Elastic Strength.*—If it is desired to keep working stresses by a certain margin within the limits of elasticity, it becomes important to know for other than simple direct stresses whether the breaking down occurs for a given value of the greatest principal stress (Art. 14) or for a given value of the greatest principal strain, which is influenced by the lateral strains produced by the other principal stresses (see Art. 19).

There are three theories as to when elastic failure takes place, viz.—

(1) For a certain value of the maximum principal stress.

(2) For a certain value of the maximum principal strain.

(3) For a certain value of the maximum shearing stress, this being proportional to the greatest difference between principal stresses (see (2), Art. 15, and (4), Art. 18).

If the second theory is correct, the elastic strength of a piece of material in which the maximum principal stress is tensile, for example, will be lessened by lateral compression and increased by lateral tension. Accounts of some very interesting experiments bearing on this question have been published by Mr. J. J. Guest and others;<sup>1</sup> these experiments tend to confirm the third theory for ductile materials, and the first one for brittle materials, intermediate materials following some intermediate law. Mr. Scoble<sup>2</sup> has suggested that the condition—

$$p - ap' = b$$

where  $p$  and  $p'$  are the greatest and least principal stresses and  $a$  and  $b$  are constants may be the law of yielding for all materials, the constants being different in different materials. Thus  $a$  might be near zero in a brittle material and approximate to unity in ductile materials. Lüders' lines (Art. 24) also offer some support to the third theory. The question as to the deciding factors of *ultimate* strength is mentioned in Art. 37.

In this book the English and American practice of reckoning strength from the greatest principal stress will generally be followed. Its use must be justified by the choice of a factor of safety reckoned on the ultimate and not on the elastic strength, and varying with

<sup>1</sup> "Strength of Ductile Materials under Combined Stress," *Phil. Mag.*, July, 1900, and *Proc. Physical Society*, May, 1900. Also see "Effects of Combined Stresses on Elastic Properties of Steel," by Prof. E. L. Hancock, *Phil. Mag.*, 1906, p. 276, vol. xi., and p. 418, vol. xii. Also "Strength of Ductile Materials under Combined Stress," by Mr. W. A. Scoble, *Phil. Mag.*, 1906, vol. xii. p. 533, and later, *Phil. Mag.*, January, 1910, p. 116, or *Proc. Physical Society*, vol. xxii. p. 130, and "Strength of Brittle Materials under Combined Stress," *Proc. Physical Society*, vol. xx. p. 453, and a second paper, *Phil. Mag.*, June, 1910. Also papers by Mr. W. Mason and by Mr. C. A. M. Smith in *Proc. Inst. Mech. Eng.* for December, 1909, and various articles and letters in *Engineering* during 1909 and 1910. Also "Strength of Thick Hollow Cylinders under Internal Pressure," by Messrs. Cook and Robertson in *Engineering*, Dec. 15, 1911.

<sup>2</sup> *Phil. Mag.*, January, 1910.

circumstances, including the presence or absence of other principal stresses.

The different conclusions from the three theories may be well illustrated by the common case of one direct stress,  $p_1$ , with shear stress,  $q$ , on the same plane as in Art. 18.

The first theory gives a maximum principal stress—

$$p = \frac{1}{2}p_1 + \sqrt{\left(\frac{1}{4}p_1^2 + q^2\right)} \dots \dots \dots (1)$$

The second theory gives a maximum principal strain (see Art. 19)—

$$\begin{aligned} e_1 &= \frac{p}{E} - \frac{p'}{mE} \\ &= \frac{1}{E} \left\{ \frac{1}{2}p_1 + \sqrt{\left(\frac{1}{4}p_1^2 + q^2\right)} - \frac{1}{m} \left( \frac{1}{2}p_1 - \sqrt{\left(\frac{1}{4}p_1^2 + q^2\right)} \right) \right\} \end{aligned}$$

or,  $Ee_1 = \frac{1}{2}p_1 \left(1 - \frac{1}{m}\right) + \sqrt{\left(\frac{1}{4}p_1^2 + q^2\right)} \left(1 + \frac{1}{m}\right)$

where  $\frac{1}{m}$  is Poisson's ratio (Art. 12).

And if  $m = 4$ , and equivalent simple stress—

$$Ee_1 = \frac{3}{8}p_1 + \frac{5}{4} \sqrt{\frac{1}{4}p_1^2 + q^2} \dots \dots \dots (2)$$

The third theory gives a maximum shear stress (see Art. 18 (4)) of intensity

$$\frac{p - p'}{2} = \sqrt{\frac{1}{4}p_1^2 + q^2} \dots \dots \dots (3)$$

The differing results from the three theories is pointed out frequently in the later chapters (see Arts. 113, 122, 126, 127, and 149-153).

**26. Importance of Ductility.**—In a machine or structure it is usual to provide such a section as shall prevent the stresses within the material from reaching the elastic limit. But the elastic limit can, in manufacture, by modification of composition or treatment be made high, and generally such treatment will reduce the ductility and cause greater brittleness or liability to fracture from vibration or shock. Ductile materials, on the other hand, are not brittle, and a lower elastic limit is usually found with greater ductility. Local ductile yielding in a complex structure will relieve a high local stress, due to imperfect workmanship or other causes, thereby preventing a member accidentally stressed beyond its elastic limit from reaching a much higher stress such as might be produced in a less plastic material. Thus in many applications the property of ductility is of equal importance to that of strength.

It is the practice of some engineers to specify that the steel used in a structure shall have an ultimate tensile strength between certain limits; the reason for fixing an upper limit is the possibility that greater tensile strength may be accompanied by a decrease in ductility or in power to resist damage by shock.

The usual criteria of the ductility of a metal are the percentages of elongation and contraction of sectional area in a test piece fractured by tension. Probably the percentage elongation is the better one; smaller elongation is sometimes accompanied by greater contraction of area.

**27. Percentage Elongation.**—It was noticed in Art. 23 that in fracturing a piece of mild steel by tension there was produced previous

to the maximum load a fairly uniform elongation, and subsequently an increased local elongation about the section of fracture (see Fig. 28). In such a case the extensions on each of 10 inches, marked out on a bar 1 inch diameter before straining, were as follow:—

Inch. . . . .	1	2	3	4	5	6	7	8	9	10
Extension (inches)	0·20	0·21	0·22	0·25	0·30	0·52	0·52	0·28	0·27	0·23

Fracture occurs near the division, 6 inches from one end of the marked length. Reckoning the percentage extension on the 2 inches nearest to the fracture, which include a large proportion of the local extension, the elongation is 1·04 inch, or 52 per cent. On any greater length the local extension will not affect so large a part of the length, and the percentage extension will accordingly be less. Thus, always including the fracture as centrally as possible, the elongations are—

Length (in inches) . . .	2	4	6	8	10
Elongation per cent. . .	52	40·5	35·7	33·6	31·0

If any length  $l$  increases to a length  $l'$ , then the elongation expressed as a percentage of the *original* length is—

$$\frac{l' - l}{l} \times 100$$

From the above figures it is evident that in stating a percentage elongation it is necessary to state the length on which it has been measured. Extensions are often measured on a length of 8 inches. This does not give truly comparative results for bars of different sectional areas. For example, if on a round bar 1 inch diameter the



FIG. 28.—Elongation of tension test piece.

local contraction of section and extension of length is mainly on, say, 2 inches, *i.e.* on a quarter of the whole length, in a bar of  $\frac{1}{2}$  inch in diameter the local effect will be mainly on about 1 inch, *i.e.* on one-eighth of the whole length. The local contraction on the thicker bar will consequently add more to the total percentage elongation on the 8 inches, since the 2-inch length undergoing much local strain is a greater proportion of the whole. The general extension which occurs before the maximum load is reached is practically independent of the area of section of the bar, and would form a suitable criterion of ductility were it not too troublesome to measure it just before any waist is formed. It cannot be measured satisfactorily after fracture, as the contraction at fracture influences the ultimate extension for some distance from the fracture, the metal “flowing” in towards the waist. It is, however, sometimes calculated by subtracting the local extension on 2 inches at fracture

from the whole extension, and expressing the difference as a general extension on a length 2 inches shorter than the whole gauge length.

Professor Unwin<sup>1</sup> has pointed out that another possible method of comparing the ductilities of two bars of unequal areas of cross-section is to make the length over which elongation is measured proportional to the diameter (or the square root of the area in the case of other than round bars); in other words, to use pieces which are geometrically similar. This plan is in use in Germany, where the relation between the gauge length  $l$ , over which extension is measured, and the area of cross-section  $a$ , is—

$$l = 11.3\sqrt{a}$$

This corresponds with a length of 8 inches (or centimetres) for a bar of half-a-square-inch (or centimetre) area.

The British practice is to use a gauge length of 8 or 10 inches irrespective of the area of section, and test pieces in which the ratio  $\frac{\text{length}}{\text{square root of area of section}}$  is constant have not been commercially

adopted on account of increased expense involved in preparing specimens. Professor Unwin finds that with fixed length and fixed area of section the shape of the cross-section in rectangles, having sides of different proportions, does not seriously affect the percentage elongation.

Within considerable limits the variation in percentage extension, due to various dimensions, may be very clearly stated algebraically thus—

If  $e$  = total extension and  $l$  = gauge length,  $e$  is made up of a general extension proportional to  $l$ , say  $b \times l$ , and a local extension  $a$  nearly independent of  $l$ . That is—

$$e = a + b l$$

and percentage elongation,  $100 \cdot \frac{e}{l} = 100 \left( \frac{a}{l} + b \right)$ , a quantity which (for a given sectional area) decreases and approaches  $100b$  as  $l$  is increased.

Further, the local extension  $a$  is practically proportional to the square root of the area of cross-section  $A$ , say—

$$a = c\sqrt{A}$$

hence percentage elongation =  $100 \left( \frac{c\sqrt{A}}{l} + b \right)$ , a quantity which increases with increase of  $A$  and decreases with increase of  $l$ .

$a$  and  $b$  are constants for a given quality of material. If the percentage extensions of two pieces of the same material, but of different dimensions in length or cross-section, or both, or the extensions of two considerably different lengths on the same piece, are known, the constants  $c$  and  $b$  in the above formula can be found. Owing to the want of uniformity in ordinary materials, they can, of course, be much better determined as an average of a number of results than from two only. Having determined  $c$  and  $b$ , it is easy to predict roughly from this rational formula the elongation of another piece of the same material, but of other dimensions. This gives a method of effecting

<sup>1</sup> *Proc. Inst. C.E.*, vol. clv. p. 170. See also Publication No. 18 of Eng. Standards Committee (Crosby Lockwood) and paper by Gordon and Gulliver, *Trans. Roy. Soc. Edinburgh*, vol. xlviii. Part I.



an approximate comparison of ductilities as measured by ultimate elongation in tests made on pieces of widely different proportions. This point may be best illustrated by an example.

Given that a piece of steel boiler plate 1.332 square inches area of cross-section shows an extension of 39.5 per cent. on 4 inches length, and another piece of the same plate 0.935 square inch area shows an extension of 30.2 per cent. on 6 inches, what would be the probable elongation for this material on 8 inches length in a piece 0.5 square inch sectional area?

Using the equation—

$$\text{percentage elongation} = 100\left(\frac{c\sqrt{A}}{l} + b\right)$$

For the first piece—

$$39.5 = \left(\frac{c\sqrt{1.332}}{4} + b\right)100$$

or,  $39.5 = 28.8c + 100b \dots \dots \dots (1)$

For the second piece—

$$30.2 = \left(\frac{c\sqrt{0.935}}{6} + b\right)100$$

or,  $30.2 = 16.1c + 100b \dots \dots \dots (2)$

From (1) and (2)—

$$b = 0.184 \qquad c = 0.732$$

For a length of 8 inches, and area of section 0.5 square inch, the elongation would therefore be roughly—

$$100\left(\frac{0.732\sqrt{0.5}}{8} + 0.184\right) = 24.9 \text{ per cent.}$$

The Engineering Standards Committee have not, on account of the increased cost which would be involved in machining test pieces, considered it desirable to depart from the standard length of 8 inches for measurement of elongation for strips of plate; but on account of the greater elongation produced on this fixed length by using large cross-sectional areas, a maximum allowable limit of width has been fixed for every thickness of plate, thus limiting the area without making it absolutely fixed for the fixed gauge length.

**28. Percentage Contraction of Section.**—If a test piece is of uniform section throughout its length, and during extension uniform contraction of area goes on throughout the length, as in perfectly plastic material, the percentage contraction of area reckoned on the original area is the same as the percentage elongation reckoned on the *final* length at the time of measurement. This statement will only hold good provided that the volume of the gauged length of material remains constant, which is always very nearly true, as shown by density tests. For if *l* and *l'* are the initial and final lengths, and *A* and *A'* the initial and final areas of cross-section respectively, since the volume is practically constant—

$$l \cdot A = l' \cdot A'$$

$$\frac{l}{l'} = \frac{A}{A'}$$

and subtracting unity from each—

$$\frac{l-l'}{l'} = \frac{A'-A}{A}$$

or,

$$\frac{l'-l}{l'} = \frac{A-A'}{A}$$

The left-hand side represents the elongation reckoned on the final length, and the right-hand side represents the proportional reduction of the original area. In materials which finally draw out to a waist or neck, the proportional contraction *at fracture* will be greater than this amount, which may be looked upon as a minimum of contraction possible, except in the rare case of a specimen breaking owing to local hardness or brittleness at a place where the section is substantially larger than the remaining portions, which have become reduced by drawing out.

**29. Actual and Nominal Stress Intensity.**—As a matter of convenience, it is usual to specify the ultimate strength of material as so many pounds or tons per square inch of the *original* area of section. This may be called the nominal stress intensity, but in a ductile specimen tested to the point of fracture in tension as the piece elongates the area of cross-section contracts, so that the intensity of the *actual stress* is then greater than that of the nominal stress, being equal to the actual load divided by the diminished area of section. Hence—

$$\begin{aligned} \frac{\text{intensity of actual stress}}{\text{intensity of nominal stress}} &= \frac{\text{load} \div \text{actual (reduced) area}}{\text{load} \div \text{original area}} \\ &= \frac{\text{original area}}{\text{actual reduced area}} = \frac{A}{A'} \text{ (Art. 28)} \end{aligned}$$

In the previous article it was shown that this ratio  $\frac{A}{A'}$  is equal to  $\frac{\text{actual (increased) length}}{\text{original length}}$ , or  $\frac{l'}{l}$ , provided the volume does not alter under tensile strain. This relation suggests a simple geometrical construction to obtain a curve showing the actual intensity of stress with corresponding elongations from a curve showing the nominal stress intensity with elongations for a tensile test. In Fig. 29, if *on* represents to scale the extension for a nominal intensity of stress represented by *pn*, draw *pm* parallel to *on* to meet the axis at *m*. Set off *or* to represent to scale the original length, say 10 inches; join *rm* and produce the line to meet *pn* produced in *q*. Then *qn* represents the actual stress to scale, for with the notation of the previous article and above—

$$\frac{qn}{rn} = \frac{om}{or} = \frac{pn}{or}$$

$$\text{or, } \frac{qn}{pn} = \frac{rn}{or} = \frac{l'}{l} = \frac{A}{A'} = \frac{\text{intensity of actual stress}}{\text{intensity of nominal stress}}$$

Other points on the curve showing the actual stress intensity may be similarly found so far as *t*, where the section area of the test piece begins to change locally, and is no longer nearly uniform throughout the bar. After this point the construction fails, because the assumed

conditions no longer hold. Other points on the curve might be found by special measurements of section during a test. The last point  $w$

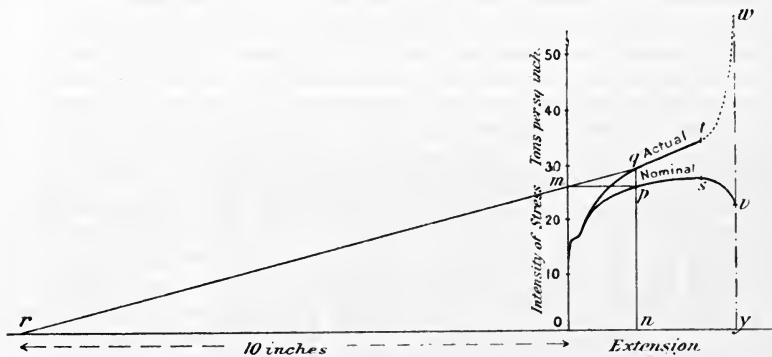

FIG. 29.

may be found by dividing the breaking load by the section at fracture, and setting off  $yw$  to represent this to scale.

**30. Effect of Shape of Test Pieces on Ultimate Strength, etc.**—Tensile test pieces are usually parallel for a length somewhat greater than that over which elongations are to be measured, the ends being left of larger section for the purpose of gripping to apply the tension. The influence upon the percentage elongation, of measuring the extension over different lengths of the parallel reduced section, has been dealt with in Art. 27, where it is shown that measurement over a shorter length gives a greater percentage elongation. It remains to state the effect of reducing the length of the parallel reduced section itself; this effect in ductile materials is of an opposite kind to that of merely measuring on a short portion of an extended parallel piece. The effect of the proximity of enlarged sections is to reduce the local drawing out, giving less elongation for a given gauge length, less contraction of area, higher ultimate strength reckoned on the original area of section, and a higher yield-point stress. These effects are due to the "flow" of the partially plastic metal from the neighbouring large sections tending to relieve the high local stress at the waist formed particularly at the later stages of the extension. Thus, in Fig. 30, piece B will show a higher ultimate strength than piece A, with smaller contraction of area. Also the elongation of the same length  $l$  will be smaller in piece B than in piece A. The increase in ultimate strength and yield point may also be due to the fact that fracture and yielding taking place in ductile materials partly or wholly by shearing (see Arts. 25 and 37), along planes oblique to the axis of the test piece, is resisted by larger sectional areas in bars B and C than in the parallel bar A<sup>1</sup> (Fig. 30).

On account of these effects the Engineering Standards Committee has specified a minimum distance of nine times the diameter as the

<sup>1</sup> See *Proc. Roy. Soc.*, vol. xlix. p. 243.

length of the parallel portion of the test piece for bars and rods, the extension being measured on not less than eight times the diameter.

*Abrupt Changes of Section.*—If the length of the parallel section be so reduced as to amount to an abrupt change, the stress in any but the most plastic materials will become unevenly distributed over the section about the place of sharp change, being concentrated near the re-entrant angle. The result of this is to cause failure under a lower *average* stress for the section, giving a low value of the ultimate

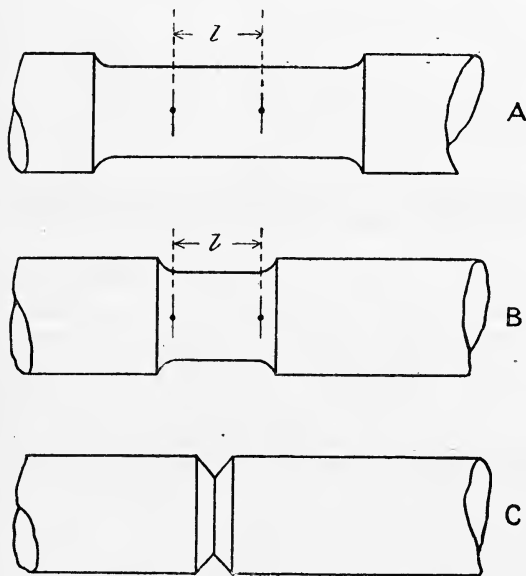

FIG. 30.

strength of the material. Extreme cases of this are the nicked specimens of rectangular section, the V-grooved specimen (C, Fig. 30), and the square-cornered collar of circular sections. The abrupt change of section will lower the value of the ultimate breaking load most in a brittle or non-extensible metal, such as cast iron or hard steel, while in very plastic material the local flow of the material caused in the region of high intensity of stress will tend to make a more uniform

distribution of the stress, and so minimise the weakening effect of the abrupt change. An attempt to investigate experimentally the distribution of stress by analogy to the stream line flow of a liquid has been made by Mr. Gulliver.<sup>1</sup>

**31. Tenacity and Other Properties of Various Metals.**—The behaviour of a typical ductile metal has been described fully in Art. 23. Stress-strain curves for two varieties of steel and a very good quality of wrought iron are shown in Fig. 31; all of these refer to round pieces of metal 1 inch diameter, and extensions are measured on a length of 8 inches. The straight line representing the elastic stage of extension has been plotted on a scale 250 times larger than that for the later stages of strain.

*Cast iron* is a brittle material, *i.e.* it breaks with very little elongation

<sup>1</sup> *Proc. Roy. Soc. Edin.*, vol. xxx. p. 38. See also "Stress Lines and Stream Lines," in *Engineering*, March 11, 1910.

or lateral contraction, and at a rather low stress. The stress-strain curve for a sample of good cast iron is shown on the large scale of Fig. 31, the ultimate strength or tenacity being just over 10 tons per square inch, and the strain being then just above  $\frac{1}{400}$ . Little if any part of the curve for cast iron is straight, the increase of extension per ton increase of stress being greater at higher stresses. It is to be noticed that the value of the direct or stretch modulus of elasticity (E), which is

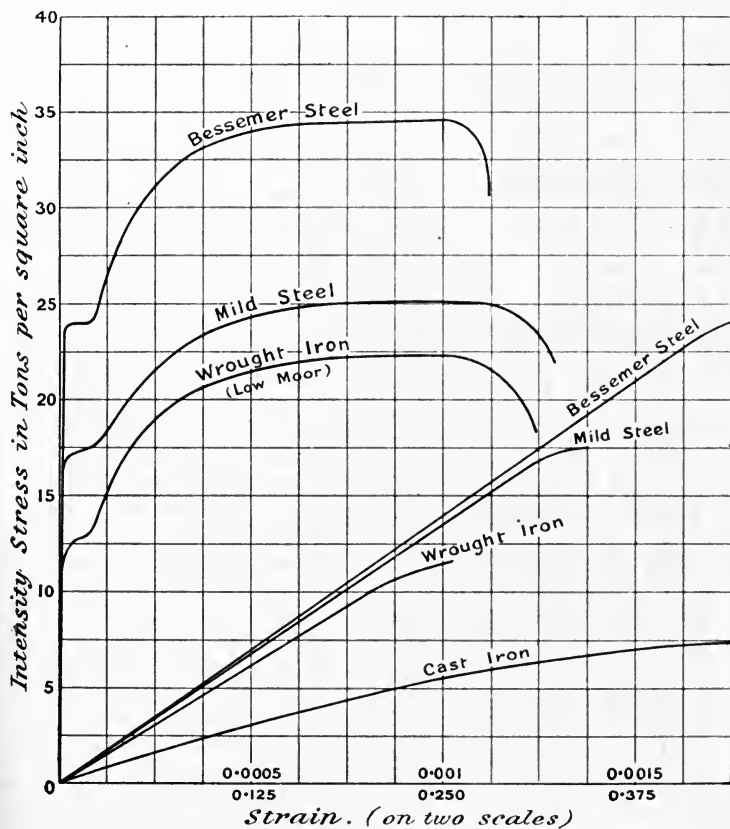

FIG. 31.—Tensile stress-strain curves.

proportional to the gradient of the curve, will differ according as it is measured on, say, the first ton per square inch of stress or over the whole range; in the former case it would be about 6000 tons per square inch, and in the latter about 4000 tons per square inch. The higher value is the more correct, as measurement should be made within the elastic limit. The elastic limit is very low for cast iron, it may be almost zero, for slight permanent sets may be detected under very low stresses. The considerable permanent set resulting, say from

tension, may be due in part to the overcoming of initial stress existing in the metal since it cooled from the liquid state; a considerable degree of tension will remove this state of stress, and if a specimen is loaded gradually for a second time the permanent set resulting is much less than in a piece not previously strained. Fig. 32 shows the load-extension curves for a piece of cast iron  $\frac{7}{8}$  inch diameter and 10 inches long, with the permanent sets resulting from the first loading. If the

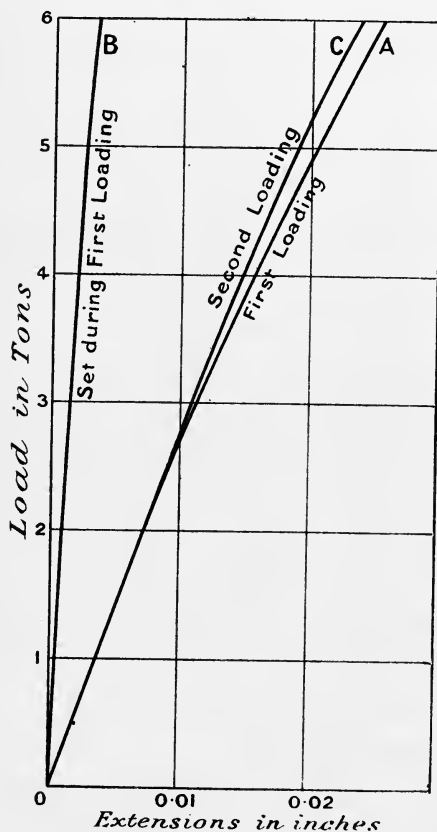

FIG. 32.—Stretch of cast iron.

permanent sets occurring during *each* loading are subtracted from the extensions, the resulting so-called elastic extensions are practically the same in each case. If the direct modulus of elasticity is calculated from these reduced extensions it will obviously be higher than if reckoned from the full extensions, but in no case is the load extension a straight line, so that the modulus obtained from, say, the first 2 tons range of load is not the same as from the first 5 tons.

The ultimate strength of cast iron in tension is usually from 7 to 10 tons per square inch; in compression it is often about 50 tons per square inch. Great differences are found in test pieces from different parts of a casting, and the properties are much modified by the rate of cooling. Thus a cast bar would generally give a different result tested in the rough with the skin on from that obtained from a similar bar with the outer material machined off; the former would show greater ultimate strength.

Owing to the liability to porosity, initial stress in cooling, etc., the working strength allowable in cast iron does not usually exceed about 1 ton per square inch in tension and 8 tons per square inch in compression.

*Wrought Iron.*—Wrought iron is a typical ductile metal, and contains over 99 per cent. of pure iron, and only about one-tenth per cent. of carbon. It comes from the puddling furnace in a spongy or pasty

state (not liquid), and subsequent hammering and rolling do not expel all traces of slag, which may be traced in layers in the finished product. The structure appears from a fractured specimen to be fibrous or laminated: this results from the rolling and working up of the crude product, but the metal itself, when examined under the microscope, is found to consist of crystalline grains (see Art. 24). Both the tenacity and ductility are greater *with* the fibres than across them. The mechanical properties differ considerably in different qualities; those of a high quality are represented in Fig. 31; lower qualities have a lower ultimate strength and smaller elongation (see table at end of chapter).

The composition of wrought iron varies in different qualities. It is desirable to keep phosphorus below  $\frac{1}{4}$  per cent. and sulphur below 0.05 per cent. Phosphorus makes the metal brittle when it is cold, and sulphur causes brittleness at a red heat.

*Steel.*—Steel was the term formerly applied to various qualities of iron which hardened by being cooled quickly from a red heat. Such material contained over  $\frac{1}{2}$  per cent. of carbon chemically combined with the iron. The tenacity and ductility of these steels is not of so much interest as that of the softer varieties. The high carbon steels are not ductile, but have a high tensile strength.

Now, much more ductile materials, having a lower tensile strength, are produced by the Bessemer, Siemens, and other processes, and are classed as mild steels. The mild steels have for many purposes replaced wrought iron, being stronger, more uniform, and more ductile; unlike wrought iron they can be cast, and when required for bars, etc., they are first cast in ingots and then rolled; the ingot being obtained from the liquid state no fibre is produced in the subsequent rolling or forging, and the metal is more homogeneous than wrought iron, and often has as little carbon present, but it is not so reliable for welding, and when a weld is necessary good wrought iron is used. These steels contain less than  $\frac{1}{2}$  per cent. of carbon, the quantity varying according to the purpose for which the steel is required. Thus steel rails may have from 0.3 to 0.4 per cent., structural steel about 0.25 per cent., and rivet steel about 0.1 per cent. of carbon. The influence of carbon on the mechanical properties of steel is very marked, and is illustrated in Fig. 33, taken from Prof. Goodman's figures. Other constituents, even in small quantities, also greatly modify the properties of steel, and apart from chemical composition, the mechanical and thermal treatment which the metal receives will, as appears in the

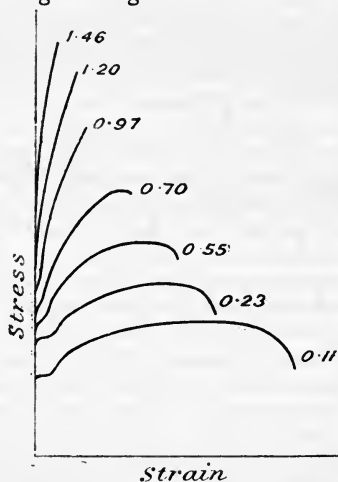

FIG. 33.—Effect of carbon on steel.

sequel, greatly modify the strength and ductility. Comparatively recently, steels containing small quantities of nickel,<sup>1</sup> chromium, vanadium, or manganese have been produced, having very high tensile strengths combined with a considerable degree of ductility.

The qualities desirable in steel for structural ship-building and machine purposes are indicated by the Standard Specifications drawn up by the British Standards Committee and published for them.<sup>2</sup> The chief requirements with respect to tensile tests and composition (when specified) are shown in the following table. All the strengths and elongations are to be measured on test pieces of standard dimensions (see complete specifications), and other mechanical tests are specified.

Material and use.	Composition.		Tenacity in tons per square inch.		Minimum elongations on 8 inches (per cent.).	Remarks.
	Maximum sulphur per cent.	Maximum phosphorus per cent.	Minimum.	Maximum.		
Structural steel for bridges and general building construction, plates, angles, etc.	0·06	{ 0·06* 0·07† }	28	32	20	* Open hearth process.
Rivet bars for above . . . . .	—	—	26	30	25	† Bessemer.
Ship plates . . . . .	—	—	28	32	20‡	
Angles, bulb angles, channel sections, etc., for ship-building . . . . .	—	—	28	33	20	‡ 16 per cent. for plates below $\frac{3}{8}$ in.
Rivet bars for ships . . . . .	—	—	25	30	25	
Railway axles . . . . .	0·035	0·035	35 to 40	—	{ 25 20 }	

The strength and ductility of steel forgings and castings is dependent upon many circumstances, and varies considerably in different parts of large pieces of material. Some idea of the values is given in the table at the end of the chapter.

*Copper.*—The tensile strength, ductility, and limit of elasticity of copper are greatly affected by mechanical treatment, such as hammering cold or rolling hot. The metal, although in some states very ductile, does not show a yield point marking a sudden breakdown of structure, as in the case of iron and steel; the deviation from proportionality between stress and strain is a gradual one (see Fig. 34).

*Alloys<sup>3</sup> of Copper. Brass.*—Brass is the name given to alloys of zinc and copper. The mechanical properties vary greatly with composition and treatment (see Fig. 34). Many brasses are very tenacious, harder than copper and cast better, but are not so ductile. Some of the

<sup>1</sup> See paper by Mr. Hadfield on "Alloys of Iron and Nickel," in *Proc. Inst. C.E.*, vol. cxxxviii.; also paper on "Chrome-Vanadium Steel," *Proc. Inst. Mech. Eng.*, Dec., 1904; and a paper in the *Proc. Inst. C.E.*, vol. xciii., on "Manganese Steel."

<sup>2</sup> By Crosby, Lockwood & Sons.

<sup>3</sup> See various Reports of Alloys Research Committee in *Proc. Inst. Mech. Eng.*, 1891-1910.



strongest alloys, such as delta metal, contain small quantities of iron; these have as high a tenacity as mild steel.

*Bronzes.*—Bronzes are, generally speaking, mainly copper and tin alloys.

*Gun-metal* is an alloy of about 90 per cent. copper and 10 per cent. tin. It is largely used for strong castings, being tough and of high tensile strength.

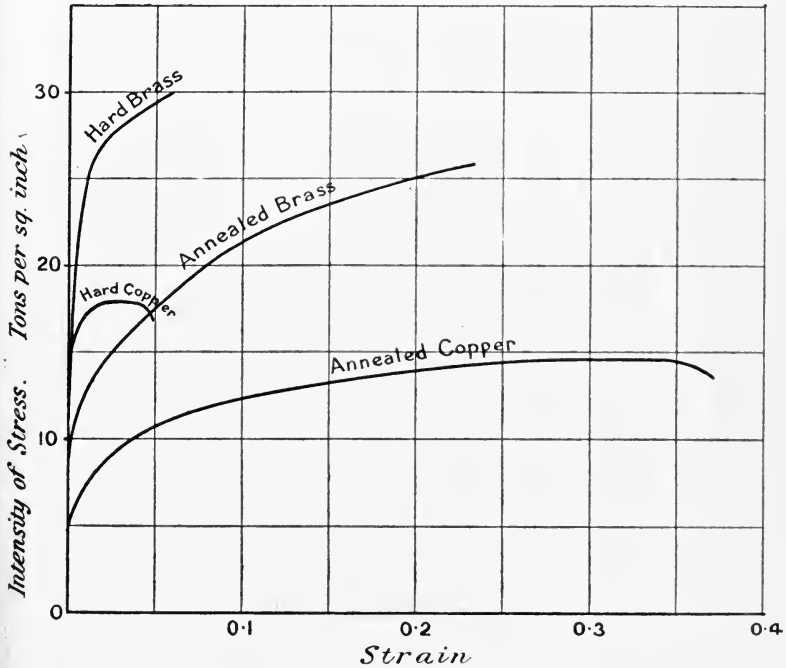

FIG. 34.

*Phosphor-bronze* is an alloy of copper and tin containing a small quantity of phosphorus. Its tenacity is high, but for malleability and ductility the tin should not exceed 5 per cent. nor the phosphorus 0.1 per cent. For hard castings, the tin may increase up to 10 per cent. and the phosphorus to 1 per cent. without producing undue brittleness.

*Manganese-bronze* usually contains zinc as well as tin and manganese. It is tenacious, ductile, hard, and offers great resistance to corrosion.

*Silicon-bronze.*—A small quantity of silicon in bronze increases its strength and ductility without reducing its electrical conductivity, as in the case of the addition of phosphorus.

*Aluminium-bronze*<sup>1</sup> does not usually contain tin, but consists of copper and aluminium, the latter not usually exceeding 10 per cent.

<sup>1</sup> See Eighth Report of Alloys Committee, *Proc. Inst. Mech. Eng.*, January, 1907; also Ninth Report, January, 1910.

With increase of aluminium to this value, the tenacity rises without brittleness. The 10 per cent. alloy has great strength (40 to 45 tons per square inch), with a fair degree of ductility.

*Aluminium.*—Aluminium is an important metal on account of its lightness. Its specific gravity is only from 2.6 (cast) to 2.75 rolled. The comparatively low tensile strength of about 5 or 6 tons per square inch when cast is increased by rolling and wire-drawing. The elastic

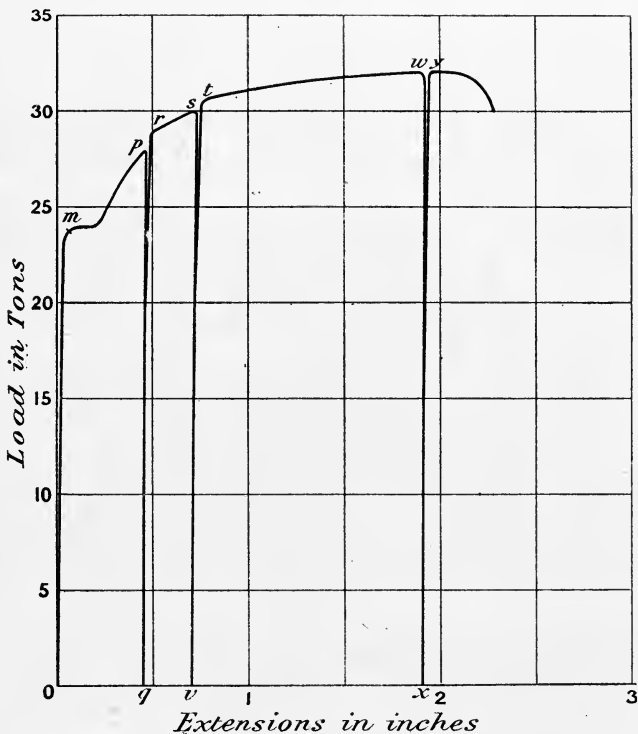

FIG. 35.

limit is low, and comparatively low tensile loads produce slow "creeping" (see Art. 23). Stresses much lower than those usually given as the ultimate strength will suffice to cause fracture if continued for a long time.

*Alloys.*—Copper, tin, and zinc are alloyed with aluminium for the purpose of increasing the tenacity and hardness.

**32. Raising the Tensile Elastic Limit and Yield Point: Overstraining.**—If a piece of steel or other ductile material is "overstrained," *i.e.* strained by some load sufficient to exceed the yield point (Art. 23), on subsequently testing the same piece it will be found to develop a new yield point at some load higher than that previously applied to it, while the elastic limit and range of proportionality between stress and strain has been reduced. For example, Fig. 35

represents the load-extension diagram for a piece of Bessemer steel bar originally 1 inch diameter, with extensions measured on a length which was originally 10 inches. The loading was three times interrupted, the load being very quickly removed and then gradually applied again from zero upwards. The first removal occurred at  $p$ ; on reloading within a few minutes, the line  $qr$  represents the partially elastic behaviour of the material up to a new yield point  $r$ , nearly a ton above the previous load at  $p$ , and greatly above the previous yield load at  $m$ .



FIG. 36.

The two later interruptions at  $s$  and  $w$  led to new and increased yield points at  $t$  and  $y$  respectively, as little time as possible elapsing before reapplying the loads.

*Effect of Time.*—If the material, after being strained, is allowed to rest for an interval before being loaded again, it exhibits the properties associated with greater hardness in comparison with a specimen reloaded immediately, its yield point being further raised and its elongation at fracture being reduced; the ultimate load may also be raised, particularly if the previous straining load has been not much below the ultimate strength. The elastic limit is also increased to a point not much below

the new yield point. These points are illustrated in Figs. 36, 37, and 38. Fig. 36 shows the load-extension curves for two almost identical pieces of steel cut from the same 1-inch bar, but treated somewhat differently. Each piece was loaded up to 27 tons at  $p$ , curve A, and then relieved from stress; the first was then immediately reloaded steadily up to the point of fracture, developing a yield point at  $q$  just below 28 tons: its subsequent strains are shown by the full line, curve B. The second piece was allowed to rest 24 hours before

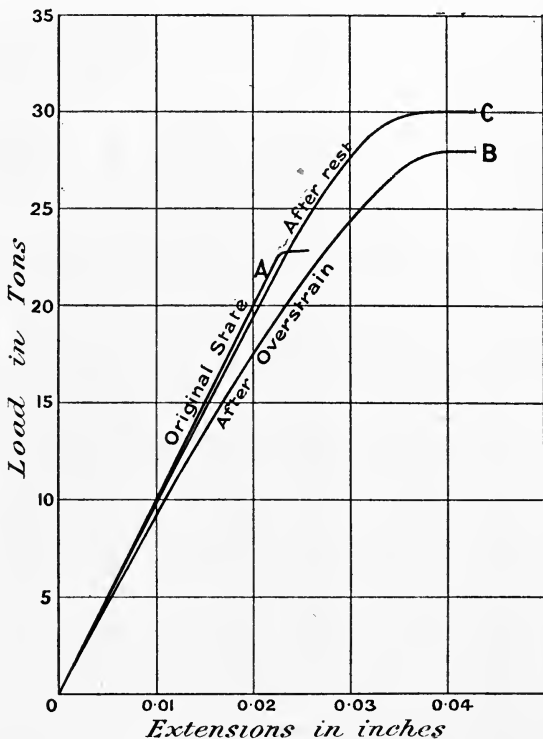

FIG. 37.

reloading, the yield not occurring until the point  $s$ , about 30 tons load, and the subsequent extensions being as shown on the dotted curve C. The ultimate extension was greater in the specimen which was not allowed a long interval in which to harden after the original overstrain, and the fractures corresponded to those for metals of different ductility (see Art. 37). The raising of the yield point is even more marked after an interval in the loading if the load is allowed to remain on instead of being removed,<sup>1</sup> and even a short stoppage in the application of the load produces a notch on the stress-strain diagram.

<sup>1</sup> See a paper by Ewing, *Proc. Roy. Soc.*, 1880.

It will be readily understood from the foregoing that the yield point and ductility may be greatly modified by the treatment, often involving great strains, which metals undergo during manufacture, such, for example, as rolling or drawing while cold. Local hardness, or lack of ductility, may also be produced in metal which has been subjected to the rough treatment of punching or shearing.

The small strains occurring before the yield point in overstrained specimens are of interest. Those for the two specimens just mentioned are shown plotted on a larger scale in Fig. 37 with letters A, B, and C, corresponding to Fig. 36. The original curve A shows practically perfect proportionality between stress and strain almost to the yield point. The curve B (immediately after overstrain) does not show nearly such proportionality, the elastic limit being also probably almost zero, while the curve C, representing the state of the material after 24 hours' rest, does not greatly differ in curvature from A. In comparing the stretch modulus  $E$  by means of the gradient of the three curves, it should be remembered that for curves B and C the area of cross-section has been reduced about 5 per cent. from that for curve A, while extensions are here shown on lengths which were 10 inches at zero load in each case. Taking account of these facts, or plotting the stress intensity instead of gross load, the values of the modulus for curves A and C are practically the same.

*Quick Recovery with Heat.*—The effect of such temperatures as the boiling point of water have very remarkable effects on some metals in hastening the recovery of elasticity after overstrain; the elasticity is quickly made almost perfect again, and the yield point is raised to a level as high as would be reached after a considerable period of rest.<sup>1</sup>

The small differences between different curves of the kinds above mentioned may be brought out more clearly by adopting a larger scale of strains in the diagram, and this may be conveniently done in a small space by a device adopted by Prof. Ewing<sup>2</sup> of "shearing back" the curves by deducting from each extension some amount proportional to the load at which it occurs. The method is illustrated by plotting the curves of Fig. 37 in Fig. 38, with each extension diminished by 0.0009 inch per ton of load at which it occurs.

*Hysteresis in Overstrain.*—Some of the strain taking place in a piece of material previously overstrained develops slowly by "creeping"; also the strains, or part of them, disappear in a similar way some time after the removal of the load. This property of temporary strain after the removal of load has been called hysteresis. A similar effect within the limits of elasticity may partially explain the ultimate failure of metals under repeated applications of stress much below the ultimate static strength, and the dependence of resistance to repeated stress upon the frequency of application of the stress (see Art. 51).

**33. Hardening by Cooling.**—Quite distinct from the various effects of overstraining, which have been called "hardening," is the hardening of

<sup>1</sup> See papers by Muir, *Phil. Trans. Roy. Soc.*, vol. 193A; and by Morley and Tomlinson, *Phil. Mag.*, 1906.

<sup>2</sup> *Phil. Trans.*, vol. 193A.

steel by quickly cooling it down from a high temperature. This is generally accomplished by plunging the hot metal in a cold liquid. The degree of hardness attained depends upon the amount of carbon in the steel and upon the rate at which it is cooled, more carbon up to at least 1.5 per cent. and quicker cooling producing greater hardness.

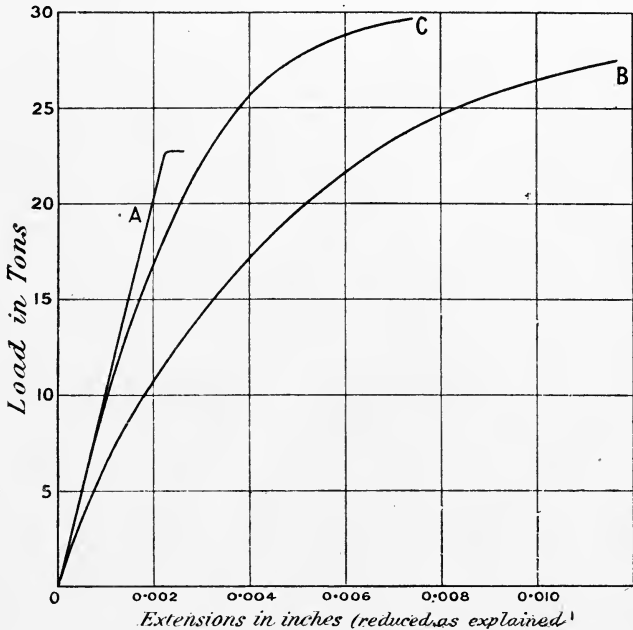

FIG. 38.

Steel hardened in this way has its tenacity raised, but becomes very brittle and has little ductility: it does not show a marked yield point, the stress-strain curve deviating gradually from straightness. Other metals, such as copper, zinc, aluminium, and brass, show a similar behaviour, inasmuch as they lose much of their elastic range and take a set at very low stresses.<sup>1</sup>

For various uses more or less of the hardness is removed from steel by reheating the metal to various temperatures according to the degree of hardness required. The process is called tempering, and the desired "temper" is recognised by the colours which appear on a clean polished surface of the metal. By heating to a sufficiently high temperature, all hardness induced by quick cooling may be removed. The precise changes which occur during hardening and tempering of steel are imperfectly understood, and acute differences of opinion are held

<sup>1</sup> See a paper by Dr. Muir, *Proc. Roy. Soc.*, vol. 71.

upon this subject by rival schools of metallurgical thought. All steels except the very mildest varieties are liable to some slight amount of hardening effect on quenching from a bright red heat.

Cast iron may be rendered hard by pouring the molten metal into chilled moulds: the outer skin, which cools first, is rendered very hard.

*Hardening at "Blue Heat."*—Hardening of mild steel and wrought iron is liable to occur if the metal is bent, hammered, or otherwise worked at a "blue heat," as it is called, *i.e.* between about 450° and 600° F., when the metal shows a blue colour on a freshly filed surface. Metal so treated, unless subsequently annealed (see Art. 34), is liable to show brittleness and unreliability,<sup>1</sup> although it may be safely worked when cold.

**34. Annealing.**—Iron and steel rendered "hard" by straining or quenching may be brought to a softer and more ductile state, more or less like its original condition, by heating to a red heat (1400° F.) and cooling very slowly; this process is called annealing.

Copper, brass, and bronzes are similarly annealed by the process of quenching or *quick* cooling from a high temperature; slow cooling hardens them, while aluminium is annealed by slow cooling.

The effect of annealing materials, such as drawn wire, is to reduce the tenacity and elastic limit and to increase the ductility as measured by the elongation, which has been reduced by much straining during manufacture (see Figs. 34 and 39). Annealing rolled rods and drawn wire generally raises the observed values of Young's modulus (*E*) for the material, probably due to relieving initial stresses existing in the material after manufacture.

In the process of making fine wire by successive drawings through

<sup>1</sup> See paper by Stromeier in *Proc. Inst. C.E.*, vol. lxxvii., 1886.

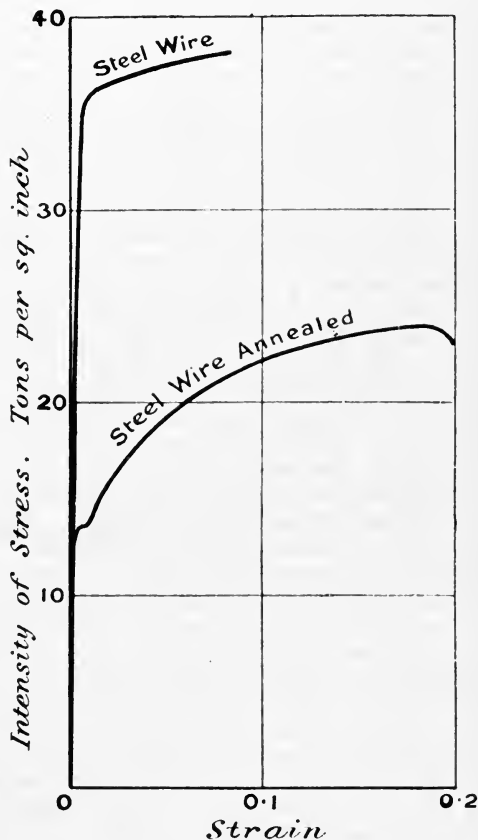

FIG. 39.—Effects of annealing steel wire.

dies of various sizes, it is necessary to anneal the material between the various stages in order to restore the ductility.

Annealing steel castings increases the tenacity and ductility and raises the elastic limit of the metal. Steel subjected to great strains in wear, as in the case of lifting chains, is annealed from time to time to prevent the metal from becoming brittle (see Art. 45).

**35. Influence of Rate of Loading.**—Within ordinary limits of time occupied in testing specimens of most materials to fracture in tension, the rate of loading does not greatly influence the ultimate load borne, the yield point, or the elongation produced. Strains take time to develop, and if the load is applied rather quickly (say in two minutes), the strains will be less than if the load is applied more slowly. If, on the other hand, the load is applied very slowly and not continuously, but with pauses during which the metal may harden (Art. 31), a notched or serrated load-extension diagram will result, showing smaller average strains than if the specimen were loaded more quickly but continuously.

Also with rates of loading so fast as to be of the nature of an impact, the elongation at fracture of mild steel is much higher than with rates such as are common in testing.<sup>1</sup> Under such quick rates or impulsive loadings it is probable, too, that the ultimate stress sustained at the yield point is greater than that under far lower rates, but the relation between stresses and the corresponding strains of exceedingly brief duration is not necessarily the same as that for static loads.<sup>2</sup> Zinc and tin record higher stresses before fracture if the load is applied quickly; the values obtained in slow tests may easily be doubled at rates which are possible in ordinary testing machines. Cement shows a similar property (see Art. 187).

**36. Compression.**—Metals have generally practically the same limit of elasticity and modulus of elasticity ( $E$ ) in direct compression as in tension, and the tension test being much easier to make than a satisfactory compression test, it is quite usual to rely on tension tests as an index of mechanical properties for nearly all metals.

For stresses beyond the elastic limit, hard or brittle materials under compression generally fracture by shearing across some plane oblique to the direct compressive stress; more plastic materials, on the other hand, shorten almost without limit, expanding laterally at the same time (see Fig. 43), and so increasing the area of cross-section as to require higher loads to effect further compressive strain. An ultimate crushing strength is therefore difficult to specify clearly. Typical compressive stress-strain curves are shown in Fig. 40. It will be seen from Fig. 43 that wrought iron cracks longitudinally after much crushing. If the metal reached a state of perfect plasticity the actual stress intensity under which the material "flows" would be constant. Then, assuming no change of volume, if  $l$  = original length of a bar,  $l_1$  = reduced length.

$A$  = original area of section, and  $A_1$  = increased area of section.  
 $A_1 l_1 = Al$  (see Arts. 28 and 29).

<sup>1</sup> See "Treatment of Gun Steel," *Proc. Inst. C.E.*, vol. lxxxix. Also paper on impact tests in *Proc. Inst. M.E.*, May, 1910.

<sup>2</sup> See "Effects of Momentary Stresses in Metals," by B. Hopkinson, *Proc. Roy. Soc.*, 1905.



$$\begin{aligned} \text{Actual final intensity of stress} &= \frac{\text{load}}{A_1} \\ &= \frac{\text{load}}{A \times \frac{l}{l_1}} = \frac{\text{load} \times l_1}{A l} \\ &= \frac{\text{load} \times l_1}{\text{volume of bar}} \end{aligned}$$

or, constant pressure intensity of plastic flow } =  $\frac{\text{load}(l - \text{reduction in } l)}{\text{volume of bar}}$

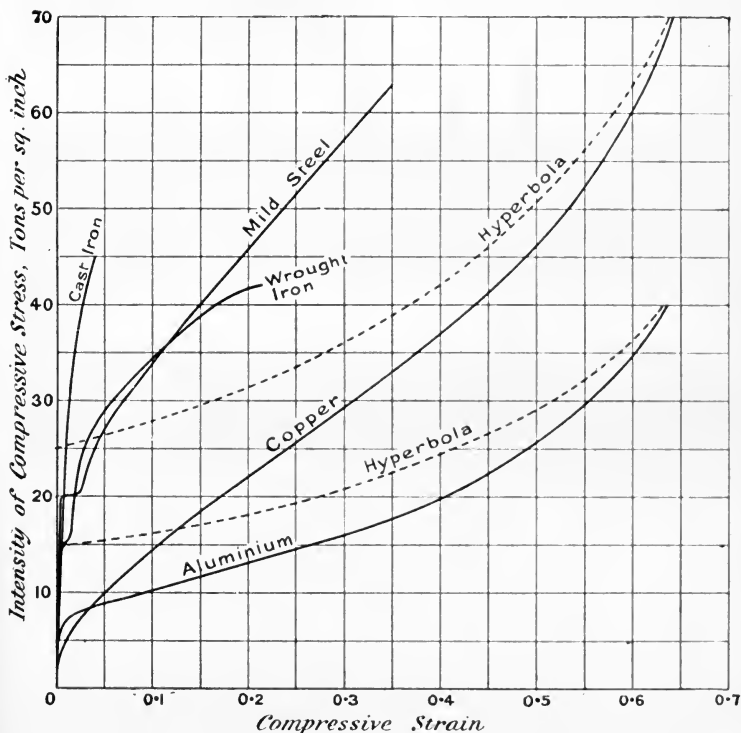

FIG. 40.—Compressive stress-strain curves.

Hence the loads (or the nominal intensity of stress), when plotted as ordinates against the compressive strains as abscissæ, would give a rectangular hyperbola, since their product is a constant. The asymptotes of the hyperbola are the axis along which strains are measured, and a line perpendicular to it corresponding to a position of unit strain.

Fig. 40 shows the manner in which the stress-strain curves for such plastic materials as copper and aluminium approach to a hyperbola, *i.e.* how nearly the materials reach to a condition of perfect plasticity, in which the metals flow continuously without increase of the actual

intensity of pressure; the pressure intensity then reached is called the pressure of fluidity.

**37. Fracture under Direct Stress.**—The form of fracture of different materials in tension and compression is a matter of considerable interest, from which various conclusions can be drawn. The fracture of ductile materials under tension, and of brittle materials under compression, generally takes place partially or wholly by shearing or sliding in directions oblique to that of the direct stress (see Figs. 41 and 42). The inclination of the surface of fracture to the



FIG. 41.—Tension fractures.

axis of direct stress is not always that in which the intensity of tangential or shear stress might be expected to be a maximum. In the case of tension of ductile materials, it must be remembered that just previous to fracture a local reduction of section takes place. This somewhat abrupt change of section tends to an uneven distribution of stress over the section just previous to rupture, and, consequently, inferences as to the intensity of shear stress on any oblique plane or other surface at fracture cannot be drawn with accuracy.

**Compression Fractures.**—In brittle materials (see Fig. 43) the strains up to the point of rupture are small, and if the material is homogeneous and isotropic the distribution of stress is probably nearly the same as within the limits of elasticity.

A piece of material under uniform compressive stress of intensity  $p$  has, on all surfaces the normal of which is inclined  $\theta$  to the axis of direct compression (see Art. 7)—

$$\begin{aligned} & (1) \text{ a tangential or shear stress } p_t = p \sin \theta \cos \theta \\ & \text{and } (2) \text{ a normal compressive stress } p_n = p \cos^2 \theta \end{aligned}$$

The intensity of shear stress is a maximum for  $\theta = 45^\circ$ , but the material is not in pure shear, on account of the accompanying normal stress  $p_n$ , and the direction of the surface of shear may be partly

determined by the action of the normal stress, the intensity of which decreases as  $\theta$  increases.

*Navier's Theory.*—Supposing the material to shear over a surface at some angle  $\theta$  to the section of wholly direct stress, the two portions of material separated by this surface are, before fracture, pressed together across the surface with a component stress of intensity—

$$p \cos^2 \theta$$

and, if a coefficient of friction  $\mu$  between the two portions be supposed, there will be a resistance to rupture of—

$$\mu p \cos^2 \theta$$

per unit of area, quite apart from the ultimate cohesive resistance to pure shear, which may be taken as a constant,  $q$ , say. Hence, at rupture—

$$p \sin \theta \cos \theta = q + \mu p \cos^2 \theta \quad \dots (1)$$

or,

$$p = \frac{q}{\sin \theta \cos \theta - \mu \cos^2 \theta}$$

Then, if rupture takes place at such an angle  $\theta$  as to involve the minimum intensity of compressive stress  $p$ —

$$\frac{dp}{d\theta} = 0$$

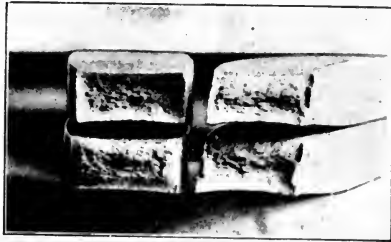
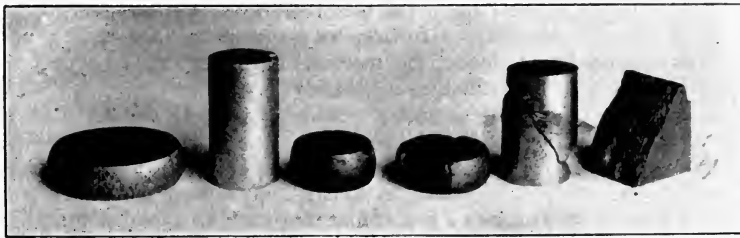

FIG. 42.—Tension fractures of mild steel.



Aluminium, after and before. Mild steel. Wrought iron. Cast iron.

FIG. 43.—Compression.

hence, differentiating—

$$\begin{aligned} \cos^2 \theta - \sin^2 \theta + \mu \cdot 2 \sin \theta \cos \theta &= 0 \\ \cos 2\theta + \mu \sin 2\theta &= 0 \end{aligned}$$

$$\cot 2\theta = -\mu = -\tan \phi = \cot \left( \frac{\pi}{2} + \phi \right) \quad \dots (2)$$

where  $\phi$  is the angle of friction, or angle of repose, and  $\tan \phi = \mu$

Finally, then—

$$\theta = \frac{\pi}{4} + \frac{\phi}{2}$$

or the inclination of the surface along which the tendency to rupture is greatest exceeds  $45^\circ$  by  $\frac{\phi}{2}$ , where  $\phi$  is the angle of repose of the grains of the material.

It is not obvious that, for the two portions ultimately separated by shearing fracture, the coefficient of friction between the particles should necessarily be the same as for two plane separate surfaces of the same material, nor, indeed, that there should be any true frictional resistance at all, but experiments on brittle metals and stones show a fair correspondence between the actual values of the angle of fracture and the angle as calculated above from the ordinary angle of friction. For cast iron the usual value of  $\theta$  is about  $55^\circ$ , corresponding to a value for  $\phi$  of  $20^\circ$  (see Fig. 43).

*Relation between Compressive and Shearing Stress.*—Assuming the above relations to hold good, and substituting the value of  $\mu$  from equation (2) in equation (1)—

$$\begin{aligned} p \sin \theta \cos \theta &= q + p \cos^2 \theta \times -\cot \theta \\ p \cos \theta \left( \sin \theta + \cos \theta \frac{\cos^2 \theta - \sin^2 \theta}{2 \sin \theta \cos \theta} \right) &= q \\ p &= 2q \tan \theta \quad \text{or} \quad 2q \frac{1 + \sin \phi}{\cos \phi} \end{aligned}$$

which gives the relation between the ultimate resistances to compressive and shear stress in terms of the angle of fracture, and also in terms of the angle of repose.

It is not easy to test such a relation experimentally; ordinary shearing operations by some scissor-like action of sharp square edges can hardly be obtained without the introduction of some other stresses, while in the case of applying torsion to a round bar, although a pure shear stress may be produced, the intensity of shear stress beyond the elastic limit cannot be estimated accurately.

The angle of fractures under pressure, as well as the ultimate resistance to crushing, is found to vary, in short pieces which do not buckle, according as the crushed material is bedded at the surfaces, receiving the external pressure on a hard unyielding substance such as millboard or plaster, or on a soft material such as a lead plate, which flows under the crushing pressure, if this exceeds its pressure of fluidity (Art. 36). The lateral tensions, induced by the ready flow of the bedding material, cause fracture to take place at a much lower load and along surfaces more inclined to that of maximum crushing stress, and even, sometimes, along faces parallel to the direction of pressure.<sup>1</sup> This is illustrated for crushing tests of Yorkshire grit in Fig. 243, details of which are given in Art. 191.

*Fractures in Tension.*—It was shown in Art. 7 that for a parallel bar under uniform tension of intensity  $p$ , the intensity of tangential or shear stress reaches a maximum value  $\frac{1}{2}p$  on surfaces the normals of which are inclined  $45^\circ$  to the direction of the tension. Experiment shows that the angle at which ductile metals actually fracture, by shearing

<sup>1</sup> See a paper by Mr. G. H. Gulliver in *Proc. Roy. Soc. Edin.*, vol. xxix. p. 432.

under tensile stress, is not greatly different from  $45^\circ$ . From this it might be inferred that the intensity of ultimate shear stress for such a material is half the ultimate tensile strength. Before drawing such a conclusion it is necessary to consider various points, such as the following:—

(1) The shear stress  $\frac{1}{2}p$ , just mentioned, is accompanied by a normal component tension  $\frac{1}{2}p$ , across surfaces inclined  $45^\circ$  to that of maximum tension (see Art. 7), which may modify the resistance of the metal to shear stress.

(2) The intensity of tensile stress at fracture is not the total pull divided by the original area of section (see Art. 29), although this nominal stress is the quantity usually quoted as the tenacity.

(3) In consequence of ductile metals drawing out locally to a waist before fracture, the area of any surface such as a cone or plane, inclined  $45^\circ$  to the axis of tension, is not  $\sqrt{2}$  times that of the minimum cross-section, nor  $\sqrt{2}$  times that of the original cross-section; in Fig. 44, for example, the area  $ef$  is  $\sqrt{2}$  times that of the cross-section in the portion of the bar not suffering local contraction;  $gh$  is  $\sqrt{2}$  times the minimum section  $aob$ , while the section  $cod$  is intermediate between the two values, and depends upon the shape of the profile at the waist.

(4) The intensity of shear stress over such a surface as  $cd$ , Fig. 44, is not uniform, being greatest at the intersection  $o$ , with the plane of minimum cross-section  $aob$ .

The difficulty of measuring the ultimate shearing strength has already been mentioned, but so far as experimental results of shear under ordinary conditions go, the ratio—

$$\frac{f_s}{f_t} \text{ or } \frac{\text{ultimate shearing resistance}}{\text{ultimate tensile strength}}$$

reckoned as usual on the "nominal" stresses, varies from about 1.2 for brittle metals to about 0.6 for very ductile metals. The value for mild steel and wrought iron is about 0.75. Such values of the shearing resistance apply to shearing stress as it is applied in ordinary constructions, rather than an ideal case of less practical importance, where the shear is "pure," or free from other straining actions.

The theory has been advanced that all fractures under tensile stress are ultimately fractures by shearing under the tangential component stress,<sup>1</sup> but this conclusion seems difficult to accept in the case of hard materials, such as cast iron and tool steel, which do not show any trace of oblique fracture (see Fig. 41).

Very ductile metals, such as aluminium, copper, and mild steel,

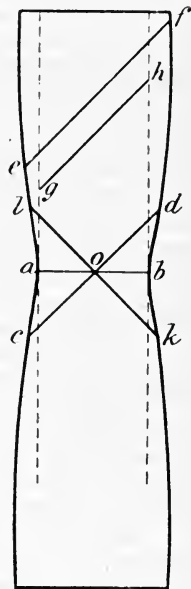

FIG. 44.

<sup>1</sup> See "The Rupture of Steel by Longitudinal Stress," *Proc. Roy. Soc.*, vol. xlix. p. 243; also "Behaviour of Materials of Construction under Pure Shear," *Proc. Inst. Mech. Eng.*, part i., 1906, and discussion.

show oblique fractures at about  $45^\circ$ , or a little more, to the axis of pull. In a round bar the greatest tendency to shear will be along the symmetrical conical surfaces, such as *lod* and *coke* (Fig. 44), and the fractures (see Fig. 41) always show some such shape in homogeneous metal. In harder material the ratio of shear strength to tenacity is usually greater, and in rolled Bessemer steel, or steels hardened by drawing out, particularly at the central core, tensile fractures are usually in the form of a truncated cone, the central part apparently tearing first, and then the softer outside material shearing. This point is illustrated by the four round bars of steel in Fig. 41. For broad flat bars of ductile metal the forms of fracture to be expected if the material is homogeneous are planes or truncated pyramids, with faces inclined a little over  $45^\circ$  to the axis of the bar. Such fractures are shown in Fig. 42.

It is a remarkable fact that, while a piece of steel or wrought iron fractured slowly shows a fine dull or even fibrous fracture in which the crystals are very small, the same steel or iron fractured very quickly shows relatively larger crystals at the surface of fracture.

**38. Effect of Temperature on Mechanical Properties.**—The tenacity, ductility, and elasticity of the most important metals do not vary to any serious extent within the limits of ordinary atmospheric temperatures; but it is, of course, well known that the strength of many metals is greatly reduced at "white hot" temperatures.

Experiments show the following effects in statical tests for wrought iron and steel at high temperatures:—

(1) *The tenacity (a)* at ordinary temperatures falls off with increased temperatures until between  $200^\circ$  and  $300^\circ$  F., when it is something of the order of 5 per cent. less than at  $60^\circ$  F. (*b*) It rises from this temperature to a maximum value at some temperature between  $400^\circ$  and  $600^\circ$  F., when it is something of the order of 15 per cent. more than at  $60^\circ$  F. (*c*) It falls continuously with further increase of temperature.

(2) *The elastic limit* falls continuously with increase of temperature.

(3) *The elongation (a)* falls with increase of temperature above the normal to a minimum value in the neighbourhood of  $300^\circ$  F., and then (*b*) rises again continuously with increase of temperature.

The elongation under tension between  $200^\circ$  and  $400^\circ$  F. does not take place steadily, but at intervals during the application of the load. When the stress and strain are plotted they present a serrated curve instead of a smooth one.

(4) *The modulus of direct elasticity (E)* decreases steadily with increase of temperature, metals which give a value of about 13,000 tons per square inch at atmospheric temperature falling to about 12,000 tons per square inch at  $500^\circ$  F.

*Low Temperatures.*—Experiments<sup>1</sup> on a very mild steel at very low temperature show progressive increase of tenacity with decrease of temperature; while the elongation practically vanishes, the material behaving like a very brittle substance. On return to ordinary temperatures no permanent change from the original properties is observed.

<sup>1</sup> See a paper by Hadfield in *Journal of Iron and Steel Inst.*, 1901; or *Engineer*, May 26, 1906; or *Engineering*, May 19, 1906.

For more detailed information on the properties of metals at various temperatures, see Johnson's "Materials of Construction," containing a summary of results at the Berlin Testing Laboratory and the Watertown U.S. Arsenal. Also for various impact tests at different temperatures see in *Proc. Inst. Civil Engineers*, vol. lx., a paper by Webster, with summary of previous experiments, and a paper in the same *Proceedings*, vol. xciv., by Andrews.

**39. Stress due to Change of Temperature.**—It is well known that metals, when free to do so, change their dimensions with change of temperature. If, however, such change of dimensions is resisted and prevented, stress is induced in the material corresponding to the strain or change of dimension prevented. Thus if a long bar is lengthened by heat, and then its ends firmly held to rigid supports, so as to prevent contraction to its original length, the bar on cooling will be in tension, and will exert a pull on the supports. Numerous applications of this means of applying a pull are to be found, such as tie-bars holding two parallel walls together, and tyres shrunk on to wheels.

The linear expansion under heat is for moderate ranges of temperature closely proportional to the increase of temperature. The proportional extension, or extension per unit of length per degree of temperature, is called the coefficient of linear expansion. Thus if  $\alpha$  is the coefficient of expansion, a length  $l$  of a bar at  $t_1^\circ$  becomes—

$$l\{1 + \alpha(t_2 - t_1)\}$$

at a temperature  $t_2^\circ$ .

If subsequently the bar is cooled to  $t_1^\circ$  and contraction is wholly prevented, a proportional strain—

$$\alpha(t_2 - t_1)$$

remains, and the corresponding tension and pull on the constraints is—

$$E\alpha(t_2 - t_1)$$

per unit area of cross-section of the bar, where E is Young's modulus for the material.

The following are the approximate linear coefficients of expansion for Fahrenheit degrees:—

Wrought iron . . . . .	0'0000067
Steel . . . . .	0'0000062
Copper . . . . .	0'000010
Cast iron . . . . .	0'0000060

For steel the tensile strain per degree Fahrenheit if contraction is prevented will be 0'0000062, and taking the stretch modulus as 13,000 tons per square inch, this corresponds to a stress intensity of

$$13,000 \times 0'0000062 \text{ or } 0'0806$$

tons per square inch. Thus the cooling necessary to cause a stress of 1 ton per square inch would be—

$$\frac{1}{0'0806} \text{ or about } 12^\circ \text{ F.}$$

The different amounts of expansion in different metals in a machine may cause serious stresses to be set up due to temperature changes. Occasionally use is made of the different expansions of two parts.

EXAMPLE 1.—If a bar of steel 1 inch diameter and 10 feet long is heated to  $100^{\circ}$  F. above the temperature of the atmosphere, and then firmly gripped at its ends, find the tension in the bar when cooled to the temperature of the atmosphere if during cooling it pulls the end fastenings  $\frac{1}{40}$ " nearer together. Assume that steel expands  $0.000062$  of its length per degree Fahrenheit, and that the stretch modulus is 13,000 tons per square inch.

The final proportional strain of the bar is—

$$\begin{aligned} & 0.000062 \times 100 - \frac{1}{40} \div 120 \\ \text{or,} & 0.00062 - 0.00021 = 0.00041 \end{aligned}$$

$$\begin{aligned} \text{Intensity of stress} &= 13,000 \times 0.00041 \\ &= 5.33 \text{ tons per square inch} \end{aligned}$$

and total pull on a bar 1 inch diameter is—

$$5.33 \times 0.7854 = 4.18 \text{ tons}$$

EXAMPLE 2.—A short bar of copper 1 inch diameter is enclosed centrally within a steel tube  $1\frac{3}{8}$  inch external diameter and  $\frac{1}{8}$  inch thick. While at  $60^{\circ}$  F. the ends are rigidly fastened together. Find the intensity of stress in each metal if heated to  $260^{\circ}$  F. Expansion coefficients as given above, E for steel 13,000, and for copper 7000 tons per square inch.

The excess of free expansion for copper over steel per unit of length is—

$$0.000100 - 0.000062 = 0.000038$$

The copper will not be elongated to the same extent as if free, and the steel will be pulled so as to be extended more than if it were free. The sum of the two linear proportional strains will be  $0.000038$  per degree, and for 200 degrees will be  $0.00076$ .

If  $e_s$  = strain in the steel,

and  $e_c$  = strain in the copper,

$$\text{then} \quad e_s + e_c = 0.00076 \quad . \quad . \quad . \quad (1)$$

The stress intensity in the steel =  $13,000 \cdot e_s$

” ” ” copper =  $7,000 \cdot e_c$

The total pull in the steel = total thrust in the copper

$$\text{therefore} \quad 13,000 \cdot e_s \cdot \frac{\pi}{4} \left\{ \left( \frac{11}{8} \right)^2 - \left( \frac{9}{8} \right)^2 \right\} = 7000 \cdot e_c \cdot \frac{\pi}{4}$$

$$\text{hence} \quad \frac{e_s}{e_c} = \frac{7}{13} \times \frac{8^2}{11^2 - 9^2} = \frac{7}{13} \times \frac{64}{40} = \frac{56}{65}$$

$$\text{or,} \quad e_s = \frac{56}{65} e_c \quad . \quad . \quad . \quad (2)$$

Substituting this value in (1)—

$$e_s \left( 1 + \frac{56}{65} \right) = 0.00076$$

$$e_s = 0.000352$$

$$e_c = 0.000408$$

Intensity of stress in steel =  $13,000 \times 0.000352 = 4.57$  tons per sq. in.

” ” ” copper =  $7000 \times 0.000408 = 2.86$  ” ”



TABLE OF ULTIMATE STRENGTHS.  
(The following are average and not extreme values.)

Material.	Tenacity in tons per square inch.	Shearing strength in tons per square inch.
Cast iron . . . . .	7 to 10	9 to 11
Wrought-iron bars . . . . .	20 to 24	15 to 18
"    plates (with fibre) . . . . .	21	16
"    "    (across fibre) . . . . .	19	14
<sup>1</sup> Steel, mild structural . . . . .	28 to 32	21 to 24
"    "    for rivets . . . . .	26 to 29	—
"    for rails . . . . .	30 to 40	—
"    castings and forgings . . . . .	25 to 35	—
"    wire . . . . .	70 to 90	—
Tool steel (carbon, hardened) . . . . .	70	45
Copper, cast . . . . .	9	—
"    hard drawn . . . . .	20	—
"    annealed . . . . .	13	—
Brass . . . . .	8	8 to 10
Gun-metal . . . . .	14 to 17	15
Phosphor-bronze . . . . .	26	24
Manganese-bronze . . . . .	35	—
Aluminium, cast . . . . .	3 to 5	—
"    rolled . . . . .	7 to 10	6
Aluminium bronze (10 per cent. copper) . . . . .	40	25
Timber . . . . .	See Art. 196	See Art. 198

TABLE OF ULTIMATE COMPRESSION OR CRUSHING STRENGTH.

Material.	Breaking strength in tons per square inch.
Cast iron . . . . .	40 to 50
Brass . . . . .	5
Copper (cast) . . . . .	20

TABLE OF COEFFICIENTS OF ELASTICITY.

Material.	Stretch, direct, or Young's modulus (E) in tons per square inch.	Transverse or shearing modulus or modulus of rigidity (N, C, or G) in tons per square inch.
Wrought iron . . . . .	12,000 to 13,000	5000 to 6000
Steel . . . . .	13,000 to 14,000	5500 to 6500
Cast iron . . . . .	6,000 to 9,000	2500 to 3500
Copper . . . . .	6,000 to 7,000	2000 to 3000
Brass . . . . .	5,000 to 6,000	2000 to 3000
Gun-metal . . . . .	5,000 to 6,000	2000 to 3000
Aluminium . . . . .	4,000 to 5,000	—
Aluminium-bronze . . . . .	7500	—

<sup>1</sup> See table in Art. 31.

## EXAMPLES II.

1. The following figures give the observations from a tensile test of a round piece of mild steel 1 inch diameter and 10 inches between the gauge points :—

Load in tons	5	10	15	16	17	18	19	20	20·5	21	21·5
Extension in inches	0·0047	0·0096	0·0145	0·0155	0·16	0·21	0·26	0·32	0·36	0·39	0·43
Load in tons	22	22·5	23	23·5	24	24·5	25	25·45	25·1	23·1	21·7
Extension in inches	0·49	0·53	0·60	0·69	0·78	0·89	1·08	2·13	2·13	2·30	2·35

Plot separate stress-strain diagrams for the elastic and ductile extensions, and find the ultimate tensile strength, intensity of stress at yield point, the percentage elongation on 10 inches, and the stretch modulus for the metal.

2. Two parallel walls, 25 feet apart, are stayed together by a steel bar 1 inch diameter, passing through metal plates and nuts at each end. The nuts are screwed up to the plates while the bar is at a temperature of 300° F. Find the pull exerted by the bar after it has cooled to 60° (*a*) if the ends do not yield; (*b*) if the total yielding at the two ends is  $\frac{1}{4}$  inch. Steel expands 0·000062 of its length per degree Fahrenheit, and  $E = 13,500$  tons per square inch.

3. Two thick copper plates are held together in contact by steel bolts. Find the increase of tensile stress in the bolts due to a rise of 200° F. in temperature if the bolt-heads and nuts have such ample bearing surface as to make the compressive strains in the copper negligible. Coefficients of expansion for Fahrenheit degrees, steel 0·000062, copper 0·00001.  $E$  for steel, 13,500 tons per square inch.

4. A weight of 3000 lbs. is supported by three parallel wires in the same vertical plane, the middle one being steel and the outer ones brass, and each having a sectional area of  $\frac{1}{4}$  of a square inch. The wires are adjusted so that each carries equal parts of the load when the temperature is 60° F. Find the stress in each wire (*a*) at 60° F., (*b*) at 200° F., and state what proportion of the whole load is carried by the steel wire. The values of  $E$  are  $30 \times 10^6$  lbs. per square inch for steel, and  $12 \times 10^6$  lbs. per square inch for brass, the coefficients of expansion for Fahrenheit degrees being 0·000062 for steel, and 0·00001 for brass.

5. A cast-iron cylinder cover is bolted to the flanges of a cast-iron cylinder by wrought-iron bolts, the total area of section of which is  $\frac{1}{10}$  of the effective area of the surfaces compressed by them. If after the bolts are tightened up the temperature of the metal rises 300° F., find the slackening in tension of the bolts per square inch area. Coefficient of expansion (F.) for wrought iron 0·000067, and for cast iron 0·000060.  $E$  for wrought iron, 12,000 tons per square inch, and for cast iron 6000 tons per square inch.

## CHAPTER III

### RESILIENCE AND FLUCTUATING STRESS.

**40. Work done in Tensile Straining.**—During the application of a gradually increasing tensile load to a bar, elongation takes place in the direction of the applied force and work is done. If during an indefinitely small extension  $\delta x$  inch, the variable stretching force is sensibly constant and equal to  $F$  tons, the work done is—

$$F \times \delta x \text{ inch-tons}$$

During a total elongation  $l$  the work may be conveniently represented by the summation of all such quantities as  $F \cdot \delta x$ , *i.e.* by—

$$\Sigma(F \cdot \delta x) \text{ or } \int_0^l F \cdot dx$$

*Graphical Representation.*—In a load-extension diagram the ordinates represent force and the abscissæ represent the elongation produced, and therefore the area under the curve, *viz.*—

$$\int F \cdot \delta x$$

represents the work done in stretching. Thus, in Fig. 45 the shaded area represents the work done.

*Scale.*—If the force scale is  $p$  tons to 1 inch and the extension scale is  $q$  inches to 1 inch, 1 square inch of area on the diagram represents  $p \cdot q$  inch-tons, which is the scale of the work diagram.

In ductile metals the whole work done up to fracture may be taken as roughly equal to the product of the total extension and the yield-point load plus  $\frac{2}{3}$  of the product of the extension and the excess of the maximum load over the yield-point load. In other words, the average load is—

$$\text{yield load} + \frac{2}{3}(\text{maximum load} - \text{yield load})$$

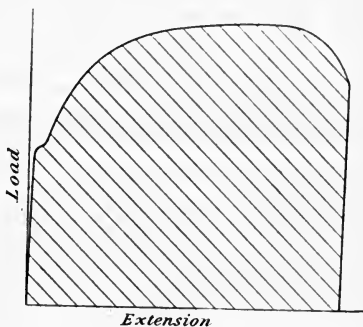

FIG. 45.

This approximation is equivalent to neglecting the strain up to yield point, and taking the remainder of the stress-strain curve as parabolic.

**41. Elastic Strain Energy.**—The work done in producing an elastic strain is stored as *strain energy* in the strained material and reappears in the removal of the load. On the other hand, the work done during non-elastic strain is spent in overcoming the cohesion of the particles of the material and causing them to slide one over another, and appears as heat in the material strained. In materials which follow Hooke's Law, the elastic portion of the load-extension diagram being a straight line, the amount of work stored as strain energy for loads not exceeding the elastic limit in tensile straining is equal to—

$$\frac{1}{2} \cdot \text{load} \times \text{extension}$$

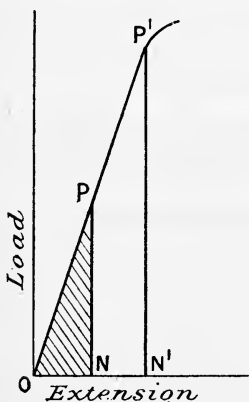

FIG. 46.

In Fig. 46 the work stored when the load reaches an amount PN is represented by the shaded area OPN, or by  $\frac{1}{2} \cdot \text{PN} \cdot \text{ON}$ , which is proportional to—

$$\frac{1}{2} \cdot \text{load} \times \text{extension}$$

**42. Resilience.**—Colloquially, resilience is understood to mean the power of a strained body to spring back on the removal of the straining forces, but technically the term is slightly modified and restricted to the amount of energy restored by the strained body. Within the elastic limit this is generally, as above for tensile straining, the product of half the load and the extension.

In a piece of metal under *uniform* intensity of tensile stress  $p$ , below the elastic limit, if  $A$  is the area of cross-section and  $l$  the length, the load is  $p \cdot A$ , and the extension is—

$$l \times \text{proportional strain, or } l \times \frac{p}{E} \text{ (Art. 9)}$$

where  $E$  is the stretch modulus. Hence the resilience is—

$$\frac{1}{2} \cdot pA \cdot \frac{p}{E} = \frac{1}{2} \cdot \frac{p^2}{E} \cdot lA = \frac{1}{2} \frac{p^2}{E} \times \text{volume of piece}$$

or the resilience is—

$$\frac{1}{2} \frac{p^2}{E}$$

per unit volume of the material. Where the tension is not uniform the expression is of similar form, but the factor is less than  $\frac{1}{2}$  if  $p$  is the maximum intensity of stress. Some particular cases will be noticed later.

*Proof Resilience.*—The greatest strain energy which can be stored in a piece of material without permanent strain is called its proof resilience. If  $f$  is the (uniform) intensity of stress at the elastic limit or proof stress, the proof resilience is then—

$$\frac{1}{2} \frac{f^2}{E} \times \text{volume}$$

This is represented in Fig. 46 by the area  $OP'N'$  for a material obeying Hooke's Law.

The proof resilience is often stated as a property of a material, and is then stated per unit volume, viz.—

$$\frac{1}{2} \frac{f^2}{E}$$

*Strain Energy beyond the Elastic Limit.*—As mentioned in Art. 5, beyond the elastic limit a small portion of the strain is generally of an elastic character. Fig. 37, Art. 32, shows that the ratio of stress to elastic or nearly elastic strain during ductile extension is not greatly different from that in purely elastic strain; in other words, it is nearly equal to the original stretch modulus. Hence the strain energy, or what may be called the “resilience beyond the elastic limit,” is approximately—

$$\frac{1}{2} \frac{p^2}{E} \times \text{volume}$$

and is represented by the area  $P''N''Q$  in Fig. 47,  $P''Q$  being approximately parallel to  $P'O$  and nearly straight. This quantity is obviously very different from the work

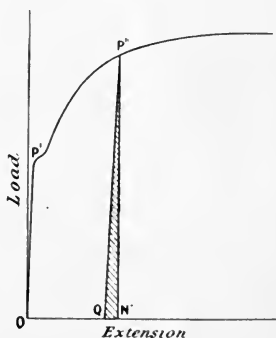

FIG. 47.

done in reaching the stress  $p$  under a steadily increasing load, which is represented by the area  $OP'N''$  and cannot be called *resilience*.

**43. Live Tensile Loads within the Elastic Limit.**—If a tensile load is suddenly applied to a bar and does not cause a stress beyond the limit of elasticity, the bar behaves like any other perfect spring, and makes oscillations in the tension, the amplitude on either side of the equilibrium position being equal to the extension which would be produced by the same load gradually applied. Hence the maximum instantaneous strain produced is double that which would be produced by the same load applied gradually.

Suppose, for example, that a tensile load  $W$  is suddenly applied to a bar of cross-sectional area  $A$ . The instantaneous strain produced is—

$$e = 2 \frac{W}{A} \div E$$

and the instantaneous intensity of stress produced is—

$$p = Ee = 2 \cdot \frac{W}{A}$$

which is twice that for a static or gradually applied load  $W$ . It is here assumed that the stress-strain curve (or value of Young's modulus) within the elastic limit is independent of the rate of loading, which is probably nearly true.

The instantaneous stress-strain diagram is shown in Fig. 48. Its area is proportional to—

$$\frac{1}{2}Ee^2 \text{ or } \frac{1}{2}\frac{(Ee)^2}{E}$$

which is the work for unit volume of material.

If a bar already carries, say, a "dead" tensile load  $W_0$ , and another "live" load  $W$  of the same kind is applied, the greatest stress reached, provided the elastic limit is not exceeded, will be—

$$\frac{W_0}{A} + \frac{2W}{A}, \text{ or } \frac{W_0 + W}{A} + \frac{\text{change of load}}{A}$$

If, on the other hand, the live load  $W$  causes a stress of opposite kind (say compressive) to that already operating, the instantaneous stress would be—

$$\frac{W_0}{A} - \frac{2W}{A}, \text{ or } \frac{W_0 - W}{A} - \frac{\text{change in load}}{A}$$

EXAMPLE.—Find the statical load which would produce the same maximum stresses as (a) a tensile dead load of 40 tons and a tensile live load of 10 tons; (b) a tensile dead load of 20 tons and a compressive live load of 30 tons.

(a) Equivalent static load = 50 + 10 = 60 tons tension.

(b) Equivalent static load = 20 - 30 = -10 tons, *i.e.* 10 tons compression.

**44. Impacts producing Tension.**—If an impulsive tensile load, such as that of a heavy falling weight, is applied axially to a light bar and the limits of proportionality of stress to strain are not exceeded, the strain energy taken up by the bar is equal to the kinetic energy lost by the falling weight if all the connections except the bar are *infinitely rigid*.

If a heavy weight  $W$  lbs. (Fig. 49) falls through a height  $h$  inches on to a stop in such a way as to bring a purely axial tensile stress on a bar of length  $l$  inches and cross-section  $A$  square inches, causing a stretch  $\delta l$ , strain  $e$ , and an instantaneous tensile stress of intensity  $p$ , then, if the stop, the falling weight, and the supports of the bar be supposed infinitely rigid—

$$W(h + \delta l) = \frac{1}{2}Ee \times A \times \delta l, \text{ or } \frac{1}{2}F \cdot \delta l$$

where  $F$  is the equivalent statical load on the bar in pounds, and  $E$  is the stretch modulus of elasticity in pounds per square inch; hence—

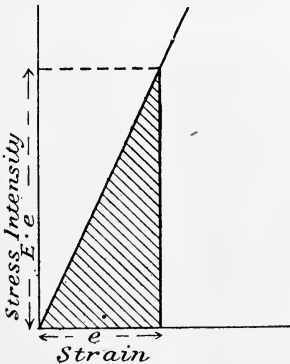

FIG. 48.

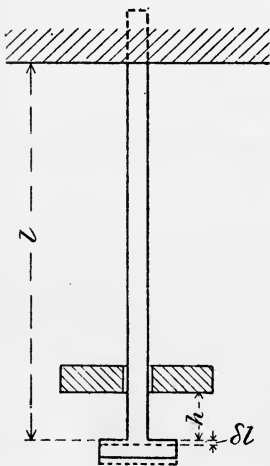

FIG. 49.

$$W(h + \delta l) = \frac{1}{2} Ee \times A \times cl$$

$$= \frac{1}{2} Ee^2 \times \text{volume of bar}$$

or, since  $\frac{p}{E} = e$ ,  $W(h + \delta l) = \frac{1}{2} \frac{p^2}{E} \times \text{volume of bar}$

and 
$$p^2 = \frac{2E \times W(h + \delta l)}{\text{volume of bar}} \text{ or } \frac{2EW h}{\text{volume}}$$

approximately when  $\delta l$  is very small compared to the fall  $h$ .

From this  $p$  may be calculated if  $E$  is known. If, as a particular case, we take  $h = 0$ , the equation becomes—

$$p^2 = \frac{2EW\delta l}{A \cdot l} = 2 \cdot \frac{W}{A} \cdot E \cdot \frac{\delta l}{l} = 2 \cdot \frac{W}{A} \cdot p, \text{ and } p = 2 \cdot \frac{W}{A}$$

as in the previous article.

Taking account of the loss of energy at impact consequent on the inertia of the bar, from the principle of the conservation of momentum, the velocity  $v$  of the weight  $W$  and the free end of the bar immediately after impact may be found by assuming the stretch to be distributed as for a static load  $W$ , as if the tension were to spread instantaneously throughout the length. Thus if  $w =$  weight of bar,

$$W \cdot \sqrt{2gh} = Wv + \frac{w}{l} \int_0^l x v dx = (W + \frac{1}{2} w)v, v = \sqrt{2gh} \frac{W}{W + \frac{1}{2} w}$$

The total kinetic energy after impact is

$$\text{K.E.} = \frac{1}{2} Wv^2 + \frac{1}{2g} \cdot \frac{w}{l} \int_0^l \left(\frac{x}{l}v\right)^2 dx = \frac{1}{2g} (W + \frac{1}{3} w)v^2 = \frac{(W + \frac{1}{3} w)W^2}{(W + \frac{1}{2} w)^2} \cdot h$$

Then equating this kinetic energy plus the gravitational work done by  $W$  and  $w$  to the gain in strain energy,

$$\text{K.E.} + W \cdot \frac{p}{E} \cdot l + \frac{w}{l} \cdot \frac{p}{E} \int_0^l x dx = \frac{1}{2} \cdot \frac{p^2 A l}{E} + \frac{w}{l} \cdot \frac{p}{E} \int_0^l x dx$$

$$p^2 - 2p \cdot \frac{W}{A} - \frac{2E}{A l} \cdot \frac{(W + \frac{1}{3} w)}{(W + \frac{1}{2} w)^2} \cdot h = 0$$

$$p = \frac{W}{A} \left\{ 1 + \sqrt{1 + \frac{2AE(W + \frac{1}{3} w)}{l(W + \frac{1}{2} w)^2}} \right\} \cdot h$$

If  $h = 0$ ,  $p = 2 \frac{W}{A}$  as in the previous article and above. If  $h$  is large compared to the extension  $\delta l$ , the term in  $p$  vanishes, and

$$p = W \sqrt{\frac{2E}{lA} \cdot \frac{(W + \frac{1}{3} w)}{(W + \frac{1}{2} w)^2}} \cdot h$$

It is not unusual to assume that the stretch modulus is the same for impulsive or very quick loadings as in a static test, although this is not certain. In this connection reference may be made<sup>1</sup> to impact experiments by Prof. B. Hopkinson, showing purely elastic stresses and strains much beyond those usually associated with the limits of elasticity,

<sup>1</sup> *Proc. Roy. Soc.*, Feb., 1905. See also "Some Experiments on Impact," in *Engineering*, April 30 and May 7, 1909.

provided the time during which the stresses exceeded this limit is of the order of  $\frac{1}{1000}$  second or less. Whether the relation of stress to strain is the same for such quick rates of applying stress as for rates several thousand times slower is unknown.

EXAMPLE.—If the impact produced by a falling weight of 2 cwt. is wholly taken up in stretching a steel bar  $1\frac{1}{2}$  inches diameter and 10 feet long, find the extension and the intensity of stress produced,  $E$  for steel being  $30 \times 10^6$  lbs. per square inch, and the height of fall before beginning to stretch the bar being 2 inches.

If  $x$  = stretch in inches, energy equation in inch-lbs.—

$$224(2 + x) = \frac{1}{2} \cdot E \cdot \frac{x}{120} \cdot \frac{\pi}{4} \left(\frac{3}{2}\right)^2 \times x$$

$$x^2 - 0.001x - 0.00203 = 0, \quad x = 0.0455 \text{ inch}$$

$$\text{stress intensity} = \frac{0.0455}{120} \times 30 \times 10^6 = 11,370 \text{ lbs. per square inch}$$

**45. Resistance to Shocks.**—The capacity of a piece of material to take up the energy of a blow is evidently some guide as to its suitability for constructions subject to shocks. A question of interest arises as to whether the *proof resilience*, or the total work done in fracturing the piece, is the better criterion. Several points deserve consideration.

(1) A measure of capacity to resist blows without permanent injury is the proof resilience or energy stored up to the elastic limit, which is proportional to the area  $P'N'O$ , Fig. 46. This quantity being determined from a static or slow-loading test, will only accurately measure the capacity to resist blows without injury provided the magnitudes of the strains are independent of the rate of application of stress.

(2) The total work done in fracturing material is a guide to its capacity when not previously overstrained to resist fracture by a single blow. Whether this is the same for very quick loading as for slow loading depends on whether the non-elastic strains and stresses are the same in the two cases—probably both the extreme stresses and strains are generally greater for very quick rates of loading, and consequently resistance to fracture is greater.

(3) There is no necessary relation between the proof resilience and the work done in fracturing a material, either slowly or quickly by a single application of stress, or by repeated stresses.

In fracture by repeated equal or unequal blows, the total energy expended will evidently not be the same as in the case of fracture by one blow. If a single blow of energy proportional to the area  $OP'P''N''$ , Fig. 47, produces a stress proportional to  $P''N''$ , the elastic strain energy will be proportional to some area such as  $P''N''Q$ . The resulting hardening (Art. 32) will increase the capacity to take up elastic strain, but this will involve the production of higher stresses from a given blow. The capacity to absorb shocks by plastic strain, after being thus diminished, may be considerably restored by annealing, as in the case of lifting chains, etc.

The relation of the total energy expended up to fracture after several shocks, to that for fracture by a single shock, will evidently



not be simple, and will depend on the magnitude of the various shocks and the amount of hardening resulting. Also the energy of a final blow producing fracture after other lesser blows will evidently depend on the magnitude of the previous blows—a fact sometimes lost sight of in testing materials to destruction by repeated blows of increasing magnitude, and estimating the resisting capacity by the energy of the final blow.

The energy stored up to the elastic limit, or the work done in fracturing a material when all of it is under the same intensity of stress, is most conveniently expressed per unit volume of the material, and as such is a property of the material. But for different-shaped pieces under a given straining action, the distribution of stress is different, and the resilience or work done during straining to fracture is different, being partly a function of the geometrical form. For example, two such pieces as A and B of the same material (Fig. 50) would show a very different proof resilience; the piece B would have a smaller actual resilience than the piece A, and a still smaller resilience per unit of volume than piece A.

Let  $f$  be the intensity of the proof tensile (or compressive) stress for the material, *i.e.* the intensity of stress at the elastic limit. Then, since the minimum cross-section of B is the same as that for A, the total proof load carried by either piece will be the same; the stretch of B is evidently less than that of A, and hence the resilience, which is half the product of the load, and the stretch is less for B in proportion as the stretch is less. The ratio—

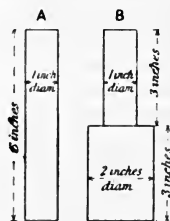

FIG. 50.

$$\frac{\text{stretch of A}}{\text{stretch of B}} \text{ is evidently } \frac{1}{\frac{1}{2} + \frac{1}{2} \times \frac{1}{4}} \text{ or } \frac{8}{5}$$

the stress in the lower part of B being only  $\frac{1}{4}f$ .

The resilience of A is (Art. 42)—

$$\frac{1}{2} \frac{f^2}{E} \times \text{volume} = \frac{1}{2} \cdot \frac{f^2}{E} \cdot \frac{\pi}{4} \times 6$$

The resilience of B is—

$$\text{for upper part, 1 inch diameter, } \frac{1}{2} \frac{f^2}{E} \cdot \frac{\pi}{4} \cdot 3$$

$$\text{for lower part, 2 inches diameter, } \frac{1}{2} \left(\frac{1}{4}f\right)^2 \cdot 4 \frac{\pi}{4} \cdot 3 = \frac{1}{2} \frac{f^2}{E} \cdot \frac{\pi}{4} \cdot \frac{3}{4}$$

$$\text{Total, } \frac{1}{2} \frac{f^2}{E} \cdot \frac{\pi}{4} \cdot 3\frac{3}{4}$$

And the ratio—

$$\frac{\text{resilience of A}}{\text{resilience of B}} = \frac{6}{3\frac{3}{4}} = \frac{8}{5} = 1.6 \text{ (as above)}$$

That is to say, the piece of the form A is capable of absorbing 60 per cent. more energy as elastic strain without permanent set than the piece B, which contains a greater volume of the same material.

To compare the two forms per unit of volume—

$$\frac{\text{volume of A}}{\text{volume of B}} = \frac{6 \times 1}{(3 \times 1) + (3 \times 4)} = \frac{2}{5} \text{ or } 0.4$$

hence,

$$\frac{\text{resilience of A per unit volume}}{\text{resilience of B per unit volume}} = \frac{1.6}{0.4} = 4 \text{ to } 1$$

To put the comparison of the two pieces in another way, if the piece B just reaches an elastic stress  $f$ , as above, by storing as strain energy the above amount of work—

$$\frac{1}{2} \frac{f^2}{E} \cdot \frac{\pi}{4} \cdot 3\frac{3}{4}$$

from an impulsive load, say, the piece A in receiving the same energy would reach only a lower stress  $p$ , such that (using the previous expressions)—

$$\frac{1}{2} \frac{p^2}{E} \cdot \frac{\pi}{4} \cdot 6 = \frac{1}{2} \cdot \frac{f^2}{E} \cdot \frac{\pi}{4} \cdot 3\frac{3}{4}, \quad \frac{p^2}{f^2} = \frac{5}{8}$$

$$\frac{p}{f} = \sqrt{\frac{5}{8}} = 0.79$$

That is, the intensity of stress induced by a given action is 21 per cent. less in a piece (A) containing 60 per cent. less material, because the whole length, instead of only a portion of the length, yields in full measure under the action.

From the foregoing comparison in a rather extreme case, it will at once be evident what ground there is for reducing the section of the shank of a bolt, subject to shocks or sudden loads, down to that at the bottom of the screw threads. To leave the shank of larger section than that at the minimum in the screwed portion, is to concentrate the effect of impulsive forces on the weakest portion of the bolt, and to increase its straining effect there.

**46. Fatigue of Metals.**—It has been found by experience that metals used in construction ultimately fracture under frequently repeated stresses very much lower than their ultimate statical strength. Further, that if the stresses are not merely repeated, but reversed, that is, the material is subjected to repeated stresses of opposite kinds, the resistance to fracture is less than if the same intensity of only one kind of stress were repeated. In such cases the material is often said to have become "fatigued." Since the cause of failure under varying stress is still imperfectly understood, it is doubtful whether the term fatigue of the whole of the metal gives a correct idea of what occurs to the material.

It may be pointed out that the treatment to which metals are subjected in slowly or quickly repeated variations of stress is quite distinct from the blows or impacts mentioned in the previous articles.

Since 1864, when Fairbairn published in the *Philosophical Transactions of the Royal Society* results of some experiments on this subject, many important researches upon it have been carried out, and others are at present in progress. Some mention of the most important will now be made: the term "varying" stresses must be understood to mean stresses of the same kind, fluctuating between a maximum and a minimum value, whilst the term "reversed" stresses will be reserved for fluctuations from one kind of stress to that of an opposite kind, e.g. from tension to compression.

**47. Wöhler's Experiments.**<sup>1</sup>—Much light is thrown on the behaviour of iron and steel under fluctuating stresses by the lengthy researches of Wöhler. The experiments included torsional, bending, and simple direct stresses. The most important deductions from these experiments are: (1) That the resistance to fracture under fluctuating stresses depends within certain limits on the range of fluctuation of stress, i.e. upon the algebraic difference between the maximum and minimum stress, rather than upon the maximum stress; and (2) That reversed stresses (tensile and compressive) much below the static breaking stress, and even well within the ordinary elastic limit, are sufficient to cause fracture if repeated a great number of times.

The second point may be illustrated by the following Table I. and Fig. 51. The material selected is an axle-iron made by the Phoenix Co., and subjected to equal and opposite tension and compression produced by bending action on a rotating bar. The ultimate strength of this material, as determined by ordinary statical tension tests, was about 23 tons per square inch, and the elongation about 20 per cent.

TABLE I.  
(STRESSES IN TONS PER SQUARE INCH.)

Maximum stress (tension).	Minimum stress (compression).	Range of stress.	Number of repetitions before fracture.
+ 15·3	(-) 15·3	30·6	56,430
14·3	14·3	28·6	99,000
13·4	13·4	26·8	183,145
12·4	12·4	24·8	479,490
11·5	11·5	23·0	909,840
10·5	10·5	21·0	3,632,588
9·6	9·6	19·2	4,917,992
8·6	8·6	17·2	19,186,791
7·6	7·6	15·2	132,250,000 (not broken)

Fig. 51 shows the ranges of stress plotted as ordinates against the

<sup>1</sup> A full description is given in *Engineering*, vol. xi., 1871. Also a good account with numerous results and discussion is given in Unwin's "Testing of Materials" (Longmans); also in *Brit. Assoc. Report*, 1887, p. 424.

repetitions necessary to cause fracture as abscissæ. For an indefinitely great number of repetitions the curve approaches a value of about 15·2 tons per square inch range, corresponding to a maximum tensile or compressive stress of about 7·6 tons per square inch, a value probably

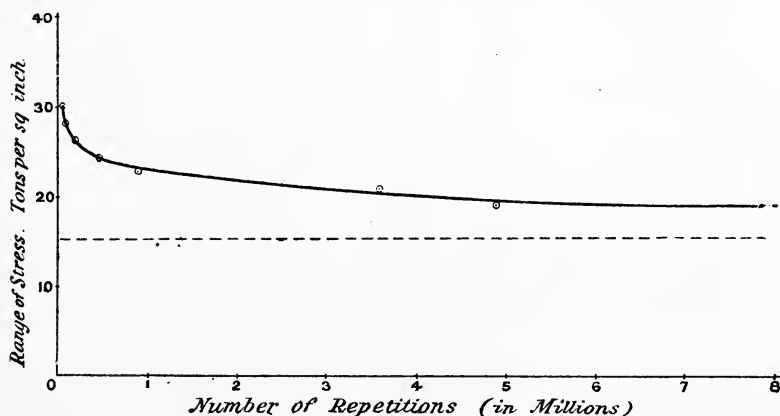

FIG. 51.

well below the ordinary elastic limit of the material. The range is called the "limiting range of stress," for which the number of repetitions necessary to cause fracture becomes infinite.

These results, although rather more regular than some others, may be regarded as typical in character of those for wrought irons and steels of various strengths. The harder high carbon steels show a higher limiting range of stress than the softer or milder steels.

The dependence of endurance under fluctuating stress upon the range of stress may be illustrated by the following table (II.) of results of pure tension tests of the above metal:—

TABLE II.  
(STRESSES IN TONS PER SQUARE INCH.)

Maximum stress.	Minimum stress.	Range of stress.	Number of repetitions before fracture.
22·92	0	22·92	800
21·01	0	21·01	106,910
19·10	0	19·10	340,853
17·19	0	17·19	409,481
17·19	0	17·19	480,852
15·28	0	15·28	10,141,645
+21·01	+9·55	11·46	2,373,424
+21·01	+11·46	9·55	4,000,000 (not broken)

Here the limiting maximum stress for repeated stresses is about 15·28 tons per square inch with application and complete removal of the load, and about 21 tons per square inch when only about half the load is removed. Thus the limiting maximum stress for the three types of fluctuating load are somewhat as follows:—

Kind of repeated load.	Limiting maximum stress.	Limiting range.
Completely reversed . . . . .	7·6	15·2
From maximum to zero . . . . .	15·28	15·28
From maximum to half load . . . . .	21·01	about 10

From these figures it is evident that in such tests the question of endurance or failure under fluctuating stress depends more upon the range than upon the maximum stress imposed.

No evidence exists that any similar conclusion would hold for other than limiting stresses, *e.g.* there is no evidence that the above material, if subjected to repeated stresses of the same kind and having a maximum intensity of, say, 7 tons per square inch, would be safer if the minimum stress were 5 tons per square inch than if it were 2 tons per square inch or zero, provided that by stress is understood the resisting force exerted by the material, and not simply the force calculated from the external load, independent of whether the increase of load is applied suddenly or otherwise (see Art. 43).

Spangenberg continued Wöhler's experiments on the same machines, and obtained similar results for iron and steel and copper alloys. Extensive results of the same kind have been published by Bauschinger<sup>1</sup> and by Sir B. Baker<sup>1</sup> for iron and steel. A few results are quoted for various irons and steels in Table III. These are selected from more extensive tables to be found in Unwin's "Testing of Materials," all except the first being from Bauschinger's experiments. The stresses stated in tons per square inch are those which the metals withstood for over two million times before fracture.

Table III. shows that the "complete reversal" limit of stress varies from about  $\frac{1}{4}$  in harder steels to  $\frac{1}{3}$  in the most ductile irons and steels, of the ultimate statical strength of the material. Also that the *repetition* limit varies from 40 to 60 per cent. of the ultimate strength, being between 55 and 60 per cent. for the ductile irons and mild steels. Further, that the reversal and repetition limits in the high tenacity steels (high carbon values) are higher than in the milder and more ductile material, although *not* so large a proportion of the ultimate statical strengths.

<sup>1</sup> See summaries in Unwin's "Testing of Materials," and in *Brit. Assoc. Report*, 1887, p. 424.

TABLE III.

Material and tenacity.	Minimum stress (limiting).	Maximum stress (limiting).	Limiting range of stress.	Ratio of maximum to tenacity.
Krupp axle steel, 52 tons. . .	-14'05	+14'05	28'1	0'27
	0	20'5	20'5	0'39
	17'5	37'75	20'25	0'73
Wrought-iron plate, 22'8 tons . .	-7'15	+7'15	14'30	0'31
	0	13'10	13'10	0'57
	11'4	19'2	7'8	0'84
Bessemer steel, 28'6 tons. . . .	-8'55	+8'55	17'10	0'30
	0	15'7	15'7	0'55
	14'3	23'8	9'5	0'83
Steel rail, 39 tons. . . . .	-9'7	+9'7	19'4	0'25
	0	18'4	18'4	0'47
	19'5	30'85	11'39	0'79
Mild steel boiler plate, 26'6 tons	-8'65	+8'65	17'3	0'33
	0	15'8	15'8	0'59
	13'3	22'55	9'25	0'85

48. Reynolds and Smith's Experiments.—In 1902 Dr. J. H. Smith published,<sup>1</sup> in conjunction with Professor Osborne Reynolds, the results of a long research on reversals of stress in various materials applied by means of the inertia forces of a reciprocating weight (see Art. 182). The opposite simple tensile and compressive stresses were of approximately equal magnitudes, and the rapidity of reversal, which in Wöhler's experiments had been from about 60 to 80 fluctuations per minute, was much higher than in any previous work, being from 1300 to 2500 per minute.

The most striking result of these experiments was to show that for reversals of stress the "limiting range of stress," and the number of reversals necessary to cause actual rupture with any fixed stress, are much smaller at these high speeds, and between the speeds stated diminish with increase of speed. Fig. 52 is plotted from Smith's results for mild steel of tenacity 26 tons per square inch and elongation 29 per cent., and shows clearly the smaller range of stress for any fixed number or for an indefinitely large number of reversals at higher speeds. The speeds are not constant for either curve, as variable speed was one method employed for varying the range of stress, which was simply proportional to the square of the speed of reversal when the reciprocating weight was not varied.

Another interesting result was that cast steel of about 58 tons per square inch tenacity and 2'5 per cent. elongation in a static test did not, at these high speeds, show a higher reversal limit of stress than the 26-ton mild steel. In previous experiments at lower rates of reversal the steels of higher tenacity and lower ductility showed greater reversal

<sup>1</sup> *Phil. Trans. Roy. Soc.*, 1902, p. 265. Professor J. H. Smith has since measured the elastic deformation of a test piece under increasing alternating stresses and finds some evidence that the strain ceases to be proportional to the stress when the range of stress is approximately such as will ultimately cause rupture.—See *Journal of Iron and Steel Institute*, 1910.

limits, but these were, even in Wöhler's experiments, a smaller proportion of the higher tenacities (see last column of Table III., Art. 47).

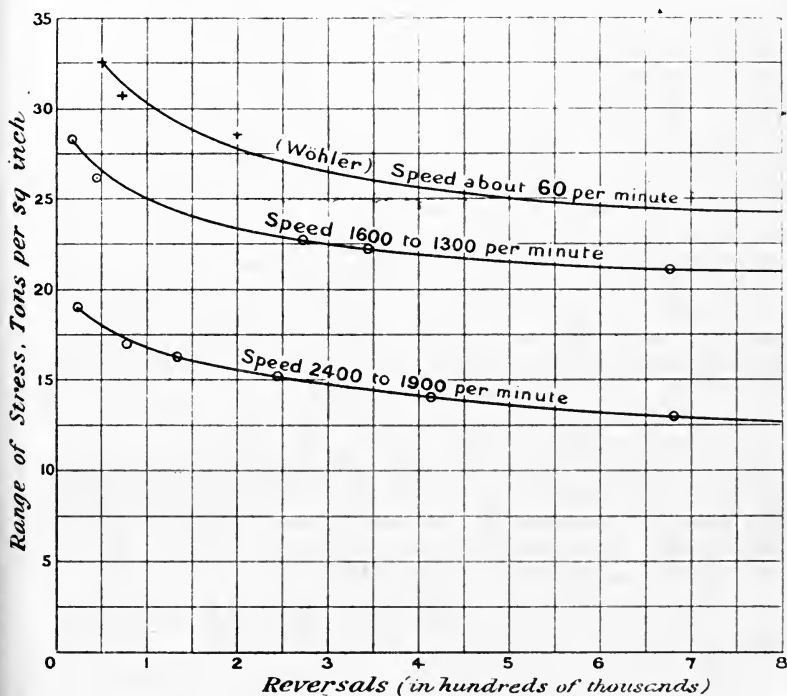

FIG. 52.

**49. Stanton and Bairstow's Experiments.**<sup>1</sup>—These were made at the National Physical Laboratory upon irons and steels in common use by means of a throw-testing machine acting upon the same principle as that of Reynolds and Smith, but taking four specimens simultaneously. The reversals were at the rate of 800 cycles per minute, and the ratio of tensile to compressive stress varied from 1.4 to 0.72 ( $\frac{7}{5}$  to  $\frac{5}{7}$ ) with two intermediate (reciprocal) proportions.

The inquiry also included the relative limiting resistance to fracture under reversed stresses of material in various forms, some of which had rather abrupt changes of section, such as in screw threads, etc.

Perhaps the most surprising result of these experiments was that the values obtained for the limiting ranges of stress agreed, so far as it was possible to compare the materials used, with those of Wöhler and Bauschinger made at about 60 cycles per minute rather than with those

<sup>1</sup> "On the Resistance of Iron and Steel to Reversals of Direct Stress," *Proc. Inst. C.E.*, 1906, vol. clxvi. p. 78. See also "Elastic Limits of Iron and Steel under Cyclical Variation of Stress," by L. Bairstow, *Proc. Roy. Soc.*, vol. A. 82, p. 483.

of Reynolds and Smith at from 1400 to 2400 per minute; apparently the change in speed from 60 to 800 does not seriously lessen the resistance to reversals of stress. In fact, the reversal limits reckoned for one million reversals were on the whole distinctly higher proportions of the tenacities than in Wöhler's experiments. Also the greater resistance of the harder steels compared to the more ductile ones as found by Wöhler at 60 cycles per minute was maintained at 800 per minute.

Within the considerable limits mentioned above (1·4 to 0·72) the ratio of tensile stress to compressive stress does not seriously affect the limiting range of stress for wrought iron.

The specimens having a sudden change of section showed diminution in the limiting range of stress, the diminution being greater in the harder than in the more ductile metal; the reduction was to 48 per cent. of the maximum for a rather hard Bessemer steel and to 65 per cent. of the maximum for the mildest steel, with intermediate proportions for other materials. Specimens having less abrupt changes of section showed diminished resistance in a smaller degree.

The research of Dr. Stanton and Mr. Bairstow also included the relation of the limiting range of stress to elastic limits as modified by repeated reversals of stress referred to in Art. 52, and microscopic investigation of the changes which take place in the material during the reversals of stress referred to in Art. 53.

#### 50. Other Experiments on Reversal of Stress.

*Rogers' Experiments.*<sup>1</sup>—These experiments included an investigation of the effect of annealing upon the endurance of steel under reversals of stress. It was found that annealing generally reduced the number of reversals sustained.

The effect of heating steel which had already sustained a large number of reversals was also investigated; no restoration of resisting power was observable in steel fatigued beyond a certain point, a result noted by other experimenters. (See also Art. 53.)

*Arnold's Experiments.*<sup>2</sup>—Professor Arnold has investigated the endurance of specimens of metal by subjecting them to bending to and fro through a standard distance on a fixed length (see Art. 182). The intensity of stress produced at the first bending is in his test beyond the elastic limit, and at subsequent strains will vary in a complex and incalculable manner as the capacity of the metal to withstand the alternating stress gets used up and as the elastic limit changes. The strains produced being large, the number of alternations necessary to produce rupture is comparatively small, and consequently the method offers a quick way of investigating the relative capacity of different metals to withstand such treatment as they are subjected to in Professor Arnold's machine. This capacity to withstand the complex stresses corresponding to repetitions of a constant *deflection* in bending does not

<sup>1</sup> "Heat Treatment and Fatigue of Iron and Steel," *Journal of Iron and Steel Institute*, No. 1 for 1905.

<sup>2</sup> *Brit. Assoc. Report*, 1904. Also *Proc. Inst. Mech. Eng.*, 1904, parts 3 and 4, p. 1172, and a paper read before the Institute of Naval Architects, April, 1908. See *Engineering or Engineer*, April, 1908.



correspond to the capacity to withstand repetitions of straining actions, which cause much lower stresses. It may be that the former in some cases is the better index of quality or suitability of a metal for a specified purpose. Professor Arnold's test does not, however, determine the limiting range of stress for an infinite number of reversals, which is perhaps the most important result of the Wöhler test.

*Eden's Experiments.*—Messrs. Eden, Cunningham and Rose,<sup>1</sup> experimenting on a rotating beam to find the limiting range of stress to withstand a million reversals, were unable to detect any diminution with increase of speed from 250 to 1300 revolutions per minute.

**51. Limiting Stress with Various Ranges of Fluctuation.**—The relation between the limiting values of the maximum stress for different ranges of stress when, as in Wöhler's experiments, the ratio of maximum stress to minimum is varied over a very wide field, may be shown in various ways graphically or algebraically. The three quantities, maximum stress intensity (say tensile)  $f_{\max.}$ , minimum stress intensity  $f_{\min.}$  (reckoned negative if compressive), and the range of stress  $\Delta$ , are evidently connected by the equation,  $\Delta = f_{\max.} - f_{\min.}$

The relation between these three quantities for practically an infinite number of stress fluctuations may be illustrated by the results of one of Bauschinger's tests of mild steel boiler plate, given in Table III., Art. 47, viz.—

	$f_{\max.}$	$f_{\min.}$	$\Delta$
(a)	26·6	26·6	0
(b)	22·55	13·3	9·25
(c)	15·8	0	15·8
(d)	+8·65	-8·65	17·3

Fig. 53 shows these values of  $f_{\max.}$  and of  $\Delta$  plotted as ordinates against the values of  $f_{\min.}$  as abscissæ. Perhaps the relation between the three quantities is better illustrated by Figs. 54 and 55, where both  $f_{\max.}$  and  $f_{\min.}$  are measured vertically, and  $\Delta$ , the range, is the vertical distance between the two curves. The portions *de* and *d'e* are mere speculations, but Stanton's results make it appear that about the portion *dd'* of either figure the range is about constant, i.e. that *de* and *d'e* are nearly parallel. Obviously the range must decrease again with higher compressive stress, but experimental evidence is lacking, this portion of the curve being of least practical importance. The shaded area is such that if both maximum and minimum stress fall within it the material will stand unlimited repetitions or reversals of stress, as the case may be, without fracture. Various empirical formulæ have been suggested to express the relations between the quantities  $f_{\max.}$  and  $\Delta$  from the experiments of Wöhler, Bauschinger, Spangenberg, and others. Of these, the best known are the formulæ of Weyrauch<sup>2</sup> and Launhardt, and Gerber's parabolic relation.<sup>3</sup> The last is expressed by the equation—

$$f_{\max.} = \frac{\Delta}{2} + \sqrt{f^2 - n\Delta f}$$

where  $f$  is the ultimate static strength or tenacity of the material,

<sup>1</sup> "Endurance of Metals," *Proc. Inst. M.E.*, 1911.   <sup>2</sup> *Proc. Inst. C.E.*, vol. lxiii.

<sup>3</sup> See Unwin's "Elements of Machine Design," vol. i. chap. ii.

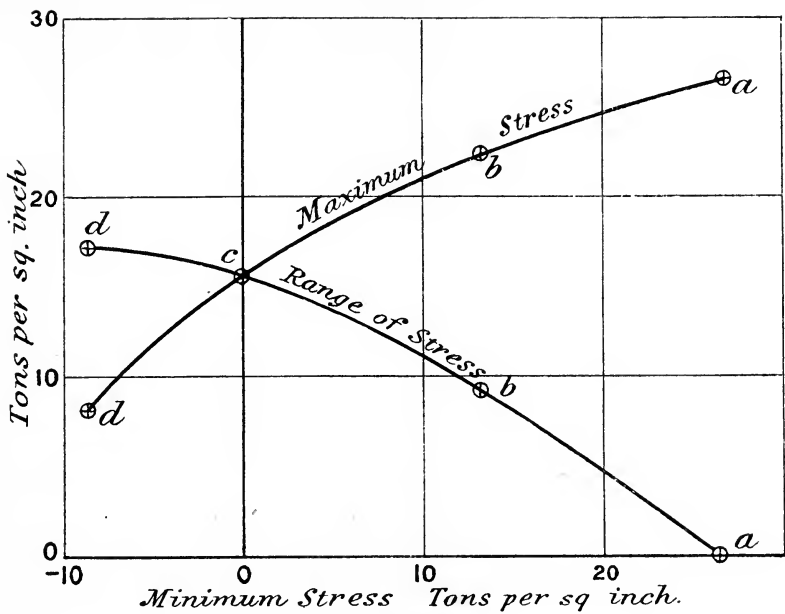

FIG. 53.

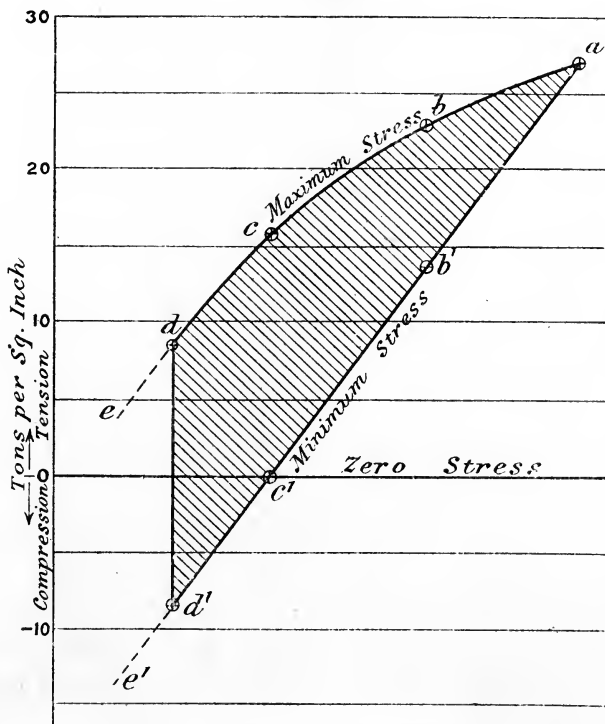

FIG. 54.—Limiting ranges of stress.

and  $n$  is a constant to be determined from experimental results. The value of  $n$  is found to vary from about 1.4 for ductile metals to above 2 for more brittle ones, its value for ductile metals of construction being generally about 1.5. This value gives a "reversal limit" of  $\frac{1}{3}f$ , and a repetition limit of  $0.61f$ .

The value 1.53 is the mean value of  $n$  deduced from the results for mild steel boiler plate quoted above, and points intermediate between

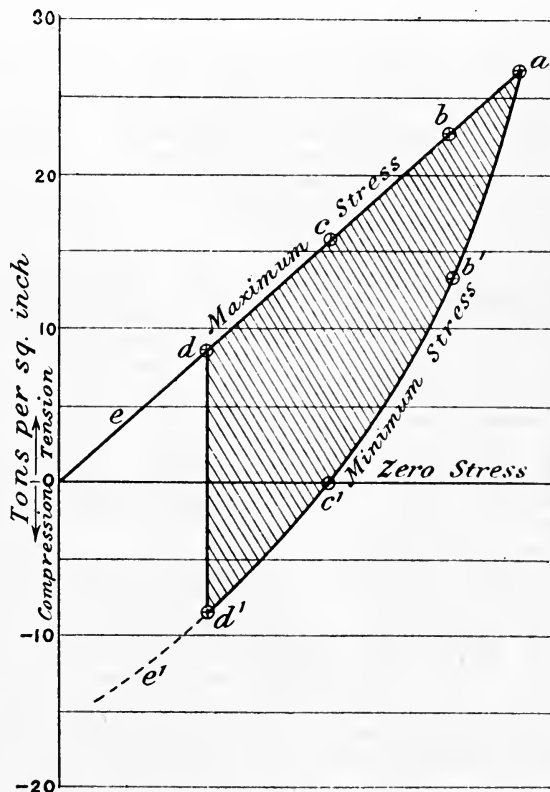

FIG. 55.—Limiting ranges of stress.

the experimental values at (a), (b), (c), and (d) have been calculated in plotting Figs. 53, 54, and 55, from which it will be noticed how closely the empirical relation fits the few observed points. How far such calculated results may be relied upon is doubtful, and in any case values of the maximum limiting stress between  $a$  and  $c$  considerably exceeding the elastic limit, although of considerable scientific interest, are not of great practical importance, since stresses which would produce considerable strains cannot be used in machines or structures. The most important practical relations, then, are those between the

repetition limit (minimum stress zero) and the reversal limit (equal and opposite tension and compression), shown in the area  $add'$ , Figs. 54 and 55, and over this region the variation of the stress is not great.<sup>1</sup> Stanton and Bairstow's experiments seem to show that for wrought iron, for some distance on either side of  $dd'$  the range  $\Delta$  is practically constant.

Owing to want of sufficient data the curves of Figs. 54 and 55 are sometimes taken as straight lines, with a repetition limit of half and a reversal limit of one-third the statical tenacity, these being average values

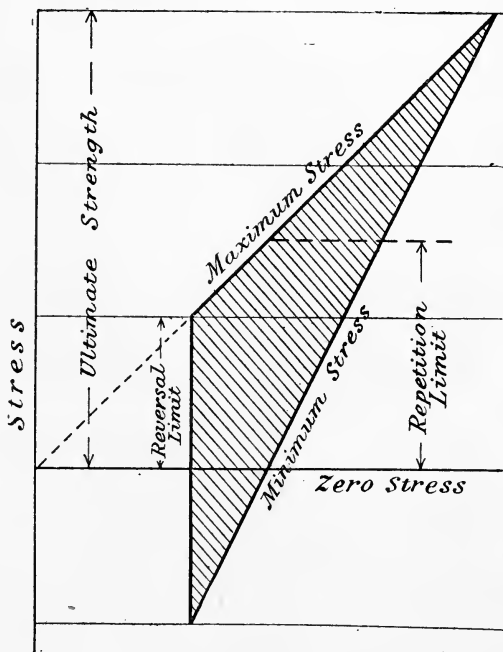

FIG. 56.

for a variety of materials. The limiting range is as shown by vertical ordinates of the shaded area in Fig. 56. The divergence of the lines of maximum and minimum stress does not greatly alter the range in the immediate neighbourhood of the reversal limit, and the method at least possesses the merit of simplicity. The relation is algebraically expressed by the equation—

$$f_{\max.} = f - \Delta$$

**52. Explanations of Failure under Fluctuating Stress.**—Many attempts have been made to explain or to throw some light upon the

<sup>1</sup> See remarks by Sir Alex. Kennedy in *Proc. Inst. C.E.*, 1906, vol. clxvi. p. 120.

failure of metals under repeated fluctuations of stress, as found by general experience and the experiments quoted in the preceding articles, and whilst there is no complete and satisfactory explanation of the phenomena observed, the various theories are interesting and instructive.

*Natural Elastic Limits.*—It is well known (see Art. 32) that the limit of elasticity may be raised by the application of stress and strain, and that the processes which wrought metal undergoes in manufacture produce an elastic limit thus artificially raised. Bauschinger found that after repeated stresses above the primitive elastic limit, the elastic limit generally rose somewhat. If the repeated stress was less than the new elastic limit to which the material was raised, Bauschinger found the material would stand an unlimited number of such repetitions.<sup>1</sup> By the application of reversed stresses in a statical experiment the elastic limit was sometimes lowered, and these modified values for both tension and compression he considered to be the natural elastic limits of the material. He suggested that these natural elastic limits were coincident with the limits of stress for an indefinite number of stress reversals.

Stanton<sup>2</sup> and Bairstow found that after pieces of material had suffered over a million reversals of stress, the elastic limit in tension was considerably below its primitive value, being slightly within the greatest tension which had been applied in the reversals, and that in compression was slightly outside the greatest compressive stress which had been applied; the limiting range of stress was practically equal to the total elastic range taken up by the material as a result of the fluctuating stresses. This offers considerable confirmation to Bauschinger's suggestion. If this theory, that for an indefinite number of reversals the limiting range of stress is coincident with the elastic range, is correct, Wöhler's and other results showing fracture with stresses much within the primitive elastic limit are in a considerable measure explained, for permanent strains, however small, especially if localised, might well cause fracture. It is, however, a remarkable fact that Bauschinger, and later Smith, found that static tests of specimens which had resisted a large number of fluctuations of load showed no diminution, but a slight increase, in tenacity.

If we regard the natural limits of elasticity as fixed for complete reversals of stress, it does not necessarily follow that the range between these natural limits is of equal magnitude for repetitions of one kind of stress, and experiments on this point are lacking. From some experiments made by Bauschinger,<sup>3</sup> it appeared that raising the tensile elastic limit lowers the compression limit, but this cannot be regarded as proved, and there is some evidence that raising the tensile limit, in a static test at any rate, may ultimately either raise or lower the compression limit.<sup>4</sup>

<sup>1</sup> See Unwin's "Testing of Materials," pp. 353 and 364, 2nd edition.

<sup>2</sup> *Proc. Inst. C.E.*, 1906, pp. 96 and 104.

<sup>3</sup> Unwin's "Testing of Materials," p. 360, 2nd edition.

<sup>4</sup> See a paper by Muir, *Proc. Roy. Soc. A.*, vol. lxxvii. p. 277.

*Hysteresis at Low Stresses.*—By experiments on long wires, Ewing has found<sup>1</sup> that for stress much below what is usually regarded as the elastic limit the strain is not strictly proportional to the stress, or that there is a lag of the strain during gradual loading; during unloading there is a lag in the diminution of strain so that a stress-strain diagram encloses a loop the width of which, at any given stress, is the difference of strain between the unloading and loading curve (see Fig. 57). In Prof. Ewing's experiments the width of the loop at the middle was of the order of  $\frac{1}{300}$  of the greatest strain. The lag in strain between cycles of fluctuating stresses may cause a material at comparatively low stresses to accumulate considerable local strains, and suggests some explanation of fracture under repeated fluctuations of stress.

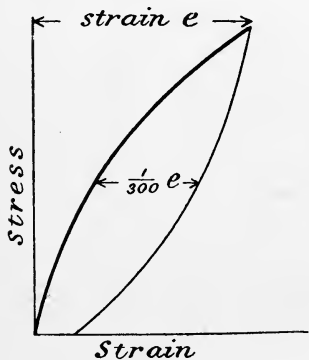

FIG. 57.

An ingenious theory built mainly on this basis has been worked out by Mr. Frank Foster.<sup>2</sup> It explains the larger limiting range, but lower maximum limiting stress for reversal than for mere repetition of load, and also the lower

limiting stresses at higher rates of reversal, as found in Smith's experiments.

*Dynamic Effect of a Live Load.*—It has been suggested that the effect of repeated fluctuations of load in producing rupture is due to the fact that the load is not very gradually applied, and that the stress produced is really greater than that supposed. The lower limiting range of stress at high rates of fluctuation, as in Smith's experiments, lends some support to such a theory. But the condition of metals, as determined by static tests of the elastic limit and tenacity after a large number of fluctuations, does not support the complete explanation by dynamic action such as may take place in a perfectly elastic body (see Arts. 43 and 44). Such an explanation giving a reversal limit of one-third and a repetition limit of one-half the tenacity (compare last paragraph of Art. 51, and Fig. 56) has been advanced, but any such explanation would have to take account of the fact that ductile metals under fluctuating stress often fracture without measurable elongation or alteration of area, whilst the tenacity is usually reckoned from statical experiments by the arbitrary standard of nominal stress on the original area, which is not the actual stress at rupture (see Art. 29).

*Critical Periods.*—It is quite probable that the coincidence of some natural period of vibration of a member of a machine with that of a periodic force impressed upon it may account for fractures which occur in practice (see Art. 160). The augmented amplitude of vibration in

<sup>1</sup> *Brit. Assoc. Report*, 1899, p. 502.

<sup>2</sup> *Memoirs and Proceedings Manchester Litt. and Phil. Soc.*, vol. xlviii. pt. ii., Jan., 1904.

such a case may well cause permanent strain, the cumulative effect of which may be very important in injuring the metal.

**53. Microscopic Investigation.**—Much attention has recently been devoted to the microscopic examination of specimens of steel which have fractured under repeated fluctuation or reversal of stress. It is believed that fracture ultimately takes place by the development of microscopic flaws into cracks by the concentration of stress produced at the edges of the region of the flaw, which gradually spreads until it leads to fracture.<sup>1</sup> Such a theory would explain the circumstance that material quite close to the area of fracture retains its full tenacity.

*Experiments of Ewing and Humphrey.*<sup>2</sup>—These included a microscopic examination of Swedish iron at intervals during the application of a sufficient number of reversals of stress to cause fracture. The observations showed that slip bands (see Art. 24) often appeared on some crystals after a comparatively small number of reversals of stress below the original yield stress, just as they do in plastic yielding. With further reversals the slip bands increase in number as well as broadening. Finally the numerous broadened slip bands developed into cracks across the crystal. These cracks quickly spread from crystal to crystal and quickly brought about fracture, probably, as mentioned above, by tearing at the edge of the crack due to a concentration of stress.

The experimenters attribute the formation of cracks to the destruction of cohesion by the grinding action on the cleavage planes (see Art. 24 on Microscopic Observations), along which slipping *to and fro* takes place in *reversals* of stress. Considerable evidence in support of this view is found in the production of a roughened surface of metal due to burring of the edges at the slip lines.

Stanton and Bairstow also examined microscopically some of their specimens (Art. 49) and traced the development of micro-cracks from slips in the crystalline grains of the metal.

Evidence of the existence of cracks in the metal previous to actual fracture was found by Rogers in the research referred to in Art. 50. Specimens which had been subjected to heat after a great number of reversals of stress, on subsequently being fractured by further reversals showed, on the surface of fracture, heat tinting in patches, indicating that when subjected to heat there had been cracks the sides of which had suffered slight oxidation.

**54. Factors of Safety for Varying Stress.**—The various experiments on fluctuating stress, as well as the results of general experience in the design and use of structures and machines, point to the use of different working stresses according to the nature of the straining actions to be endured.<sup>3</sup> If a factor of safety or ratio of ultimate statical strength to working stress of, say 3, be sufficient for mild steel to cover accidental and uncalculated straining actions, errors of workmanship,

<sup>1</sup> See Andrews on "Microscopic Internal Flaws inducing Fracture in Steel," *Engineering*, July, 1896.

<sup>2</sup> *Phil. Trans. Roy. Soc.*, vol. 200.

<sup>3</sup> See *Report of Brit. Assoc.*, 1887, p. 424.

deterioration, and such contingencies for a steady, unvarying load, then if the same allowance be made for similar contingencies in mild steel subjected to reversals of an appropriate working stress, the maximum stress would be  $\frac{1}{3}$  of the reversal limit of stress, or about  $\frac{1}{3}$  or  $\frac{1}{9}$  of the ultimate statical strength, since the reversal limit is about from 30 to 40 per cent. of the ultimate statical strength (Table III., Art. 47). The factor of safety as above defined would then be 8 or 9.

Unwin gives the following table of factors of safety for different materials and circumstances:—

TABLE OF FACTORS OF SAFETY.

Material.	Factors of safety for			
	Dead load.	Live or varying load.		Structure subject to shock.
		Stress of one kind only.	Reversed stresses.	
Cast iron . . . . .	4	6	10	15
Wrought iron and steel	3	5	8	12
Timber . . . . .	7	10	15	20

## EXAMPLES III.

1. Find the work done per cubic inch of material in the static test to fracture given in question 1, Examples II.

2. Find the total elastic strain energy or resilience of a bar of mild steel 1 inch diameter and 10 feet long, carrying a tensile load of 7 tons.  $E = 13,500$  tons per square inch.

3. Find the total proof resilience of a bar of steel  $1\frac{1}{2}$  inch diameter and 8 feet long, the tensile elastic limit being 14 tons per square inch and the stretch modulus ( $E$ ) 13,500 tons per square inch. Find also the proof resilience per cubic inch.

4. Find the intensity of stress and extension produced in a bar 10 feet long and 1.5 square inch in section, by the sudden application of a tensile load of 6 tons. What suddenly applied load would produce an extension of  $\frac{1}{20}$  of an inch? Take  $E = 13,000$  tons per square inch.

5. Estimate the dead loads equivalent to the following: (a) A dead load (tensile) of 15 tons and a live load of 20 tons. (b) A dead load (compressive) of 15 tons and a live tensile load of 20 tons. If the strain is not to exceed 0.001, find the area of section required in each case,  $E$  being 13,500 tons per square inch.

6. A load of 560 lbs. falls through  $\frac{1}{2}$  inch on to a stop at the lower end of a vertical bar 10 feet long and 1 square inch in section. If the stretch modulus ( $E$ ) is 13,000 tons per square inch, find the stress produced in the bar.

7. Find the greatest height from which the load in question 6 may fall



before beginning to stretch the bar in order not to produce a greater stress than 14 tons per square inch.

8. Two round bars, A and B, are each 10 inches long; A is 1 inch diameter for a length of 2 inches and  $\frac{3}{4}$  inch diameter for the remaining 8 inches. B is 1 inch diameter for 8 inches and  $\frac{3}{4}$  inch diameter for a length of 2 inches. If B receives an axial blow sufficient to produce a stress of 15 tons per square inch, find the stress produced by the same blow on A. How much more energy could A absorb in this way than B without exceeding any given stress within the elastic limit?

## CHAPTER IV.

### *THEORY OF BENDING.*

**55. Beams and Bending.**—A bar of material acted on by external forces (including loads and reactions) oblique to its longitudinal axis is called a beam, and the components perpendicular to the axis cause the straining called flexure or bending. This and the following four chapters deal only with beams which are straight or nearly straight. As beams are frequently horizontal, and the external forces are weights, it will be convenient to speak always of the beams as being horizontal and the external forces as vertical, although the same conclusions would hold in other cases. Members of structures are often beams as well as struts or ties; that is, there are some transverse forces acting upon them in addition to longitudinal ones.

**56. Straining Actions on Beams. Shearing Force and Bending Moment.**—Before investigating the stresses and strains set up in bending, the straining actions resulting from various systems of loading and supporting beams will be considered.

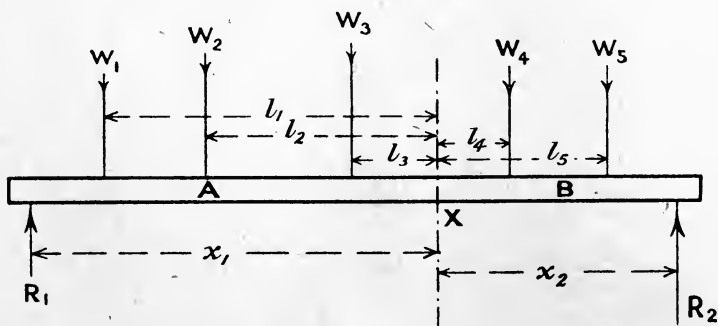

FIG. 58.

If we consider a beam carrying a number of transverse loads, as in Fig. 58, the whole beam is in equilibrium under the action of the loads  $W_1$ ,  $W_2$ ,  $W_3$ , etc., and the supporting forces or reactions  $R_1$  and  $R_2$ ; further, if we divide the beam into two parts A and B by an ideal plane of section X, each part is in equilibrium. The system which

keeps A in equilibrium consists of the forces  $W_1$ ,  $W_2$ ,  $W_3$ , and  $R_1$ , together with the forces exerted on A by B across the section X in virtue of the state of stress in the beam. We may conveniently consider these latter forces by estimating their total horizontal and vertical components and their moments. Applying the ordinary conditions of equilibrium<sup>1</sup> from statics, we conclude—

- (1) Since there are no horizontal forces acting on the piece A except those across the section X, the algebraic total horizontal component of those forces is zero.
- (2) Since the algebraic sum of the vertical *downward* forces on A is—

$$W_1 + W_2 + W_3 - R_1$$

the total or resultant *upward* vertical force exerted by B on A is  $W_1 + W_2 + W_3 - R_1$ , which is also equal to an upward force—

$$R_2 - (W_4 + W_5)$$

*Shearing Force.*—The resultant vertical force exerted by B on A is then equal to the algebraic sum of the vertical forces on either side of the plane of section X; the action of A on B is equal and opposite. This total vertical component is the *shearing force* on the section in question.

- (3) If the distances of  $W_1$ ,  $W_2$ ,  $W_3$ , and  $R_1$  from X be  $l_1$ ,  $l_2$ ,  $l_3$ , and  $x_1$  respectively, the moment of the external forces on A about the section X is—

$$M = R_1x_1 - W_1l_1 - W_2l_2 - W_3l_3$$

which is also equal to  $W_4l_4 + W_5l_5 - R_2x_2$ , and is of clockwise sense if the above expressions are positive. The moment exerted by B on A must balance the above sum, and is therefore of equal magnitude.

*Bending Moment.*—The above quantity M is the algebraic sum of the moments of all the forces on either side of the section considered, and is called the *bending moment*. The balancing moment which B exerts on A is called the *moment of resistance* of the beam at that section. The statical conditions of equilibrium show that the moment of resistance and the bending moment are numerically equal.

**57. Diagrams of Shearing Force and Bending Moment.**—Both shearing force and bending moment will generally vary in magnitude from point to point along the length of a loaded beam; their values at any given cross-section can often be calculated arithmetically, or general algebraic expressions may give the bending moment and shearing force for any section along the beam. The variation may also be shown graphically by plotting curves the bases of which represent to scale the length of the beam, and the vertical ordinates the bending moments or shearing forces, as the case may be. Some simple typical examples of bending moment and shearing-force curves

<sup>1</sup> See any text-book on Statics, or the author's "Mechanics for Engineers" (Longmans).

follow in Figs. 59 to 69, inclusive. In each case  $M$  represents bending moment,  $F$  shearing force, and  $R$  reaction or supporting force, with

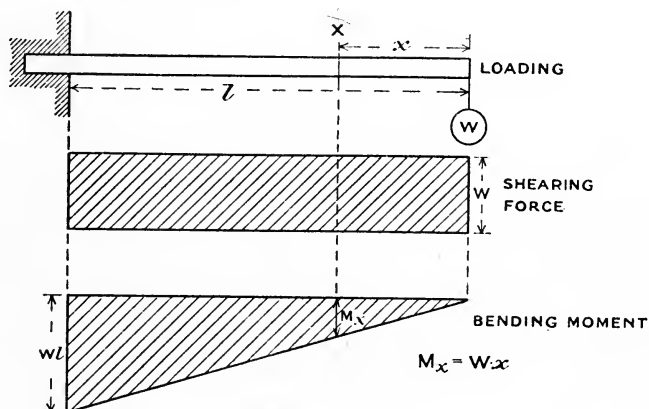

FIG. 59.—Cantilever with end load.

appropriate suffixes to denote the position to which the letters refer. Other cases of bending-moment and shearing-force diagrams will be

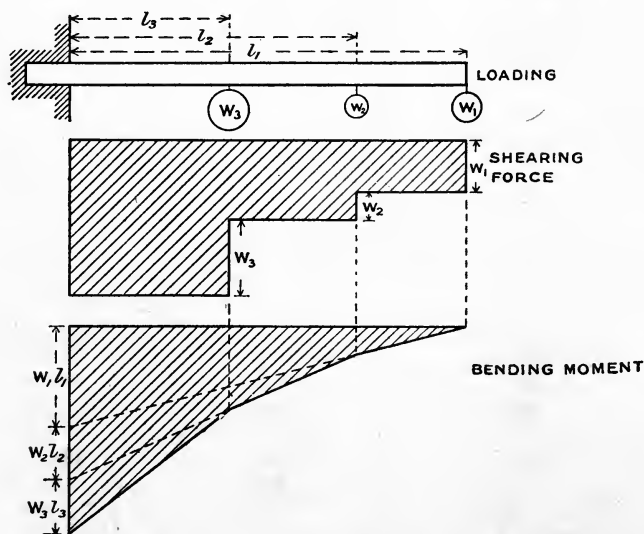

FIG. 60.—Cantilever with several loads.

dealt with later (see Arts. 84–91). In the case of moving loads the straining actions change with the position of the load: such cases are

dealt with in books on the Theory of Structures. When a beam carries several different concentrated or distributed loads the bending moment

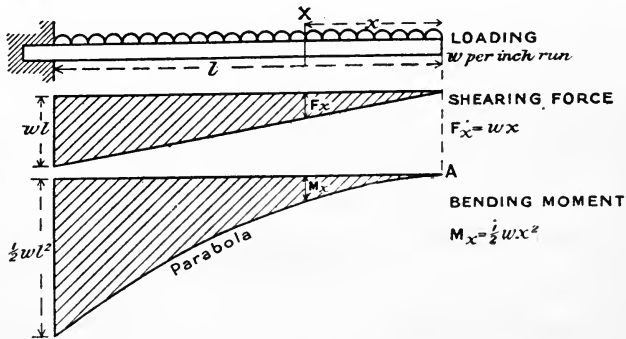

FIG. 61. —Uniformly loaded cantilever.

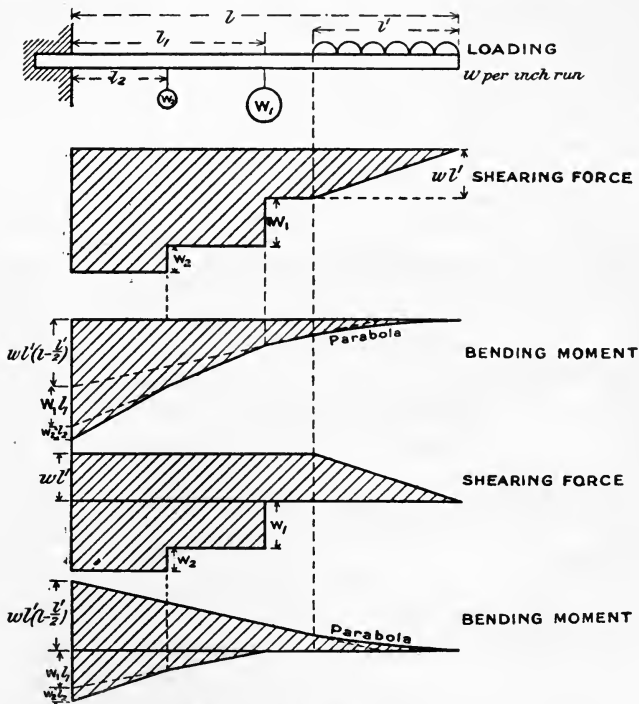

FIG. 62.

at any and every cross-section is the algebraic sum of the bending moments produced by the various loads acting separately. In plotting

the diagrams it is sometimes convenient to add the ordinates of diagrams for two separate loads and plot the algebraic sum, or to plot the two curves on opposite sides of the same base-line, and measure resultant values (vertically) directly from the extreme boundaries of the resulting diagram.

The two methods are illustrated in order in Fig. 62. Figs. 59, 60,

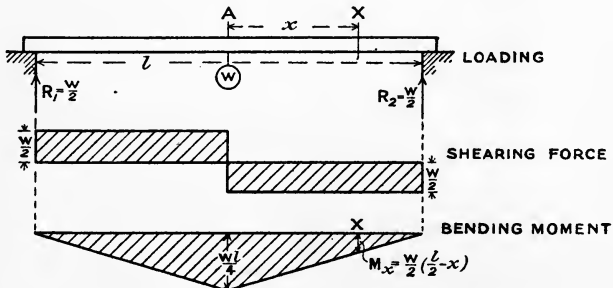

FIG. 63.—Freely supported beam with central load.

61, and 62 represent cantilevers, *i.e.* beams firmly fixed at one end and free at the other. Figs. 63, 64, 65, and 66 represent beams resting freely on supports at each end, and carrying various loads as shown. In calculating the shearing force or bending moment at any given point, or obtaining a symbolic expression for either quantity for every point over part or all the length of the beam, the first step is usually to find

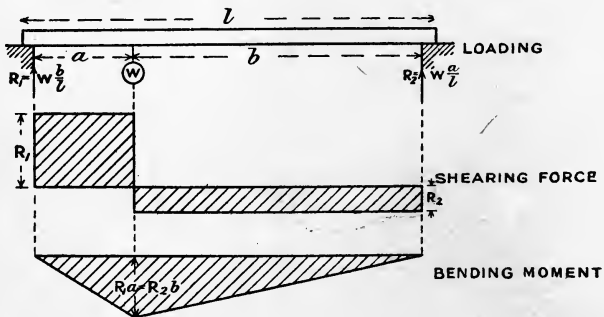

FIG. 64.

the value of the unknown supporting forces or reactions ( $R_1$  and  $R_2$ ). These can conveniently be found by considering the moments of all external forces about either support, and equating the algebraic sum to zero. When all the external forces are known, the shearing force and bending moment are easily obtained for any section, the former being the algebraic sum of the external transverse forces to either side

of the section, and the latter being the algebraic sum of the moments of the external forces to either side of the section.

The question of positive or negative sign of the resulting sums is arbitrary and not very important; but in a diagram it is well to show

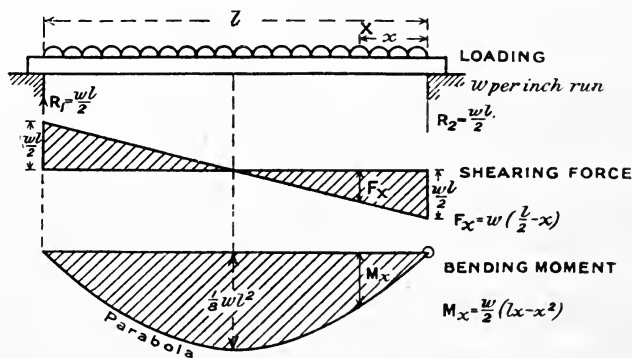

FIG. 65.—Freely supported beam with uniformly distributed load.

opposite forces and moments on opposite sides of the base-line. Take the case in Fig. 66 fully as an example. The load is uniformly spread at the rate of  $w$  per inch over a length  $c$  of the beam. The distances of the centre of gravity of the load from the left- and right-

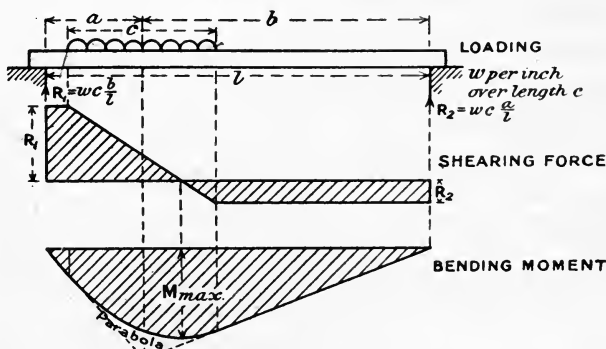

FIG. 66.—Freely supported beam.

hand supports of the beam are  $a$  and  $b$  respectively, so that  $a + b = l$ , the span of the beam between the supports.

Taking moments about the right-hand support—

$$R_1 \times l = w \cdot c \times b$$

$$R_1 = w \cdot c \cdot \frac{b}{l}$$

$$R_2 = wc \cdot \frac{a}{l}$$

The shearing force ( $F$ ) from the left support to the beginning of the load is equal to  $R_1$ .

Over the loaded portion, at a distance  $x$  from the left end, *i.e.* from  $x = a - \frac{c}{2}$  to  $x = a + \frac{c}{2}$ ,

$$F_x = R_1 - w \left\{ x - \left( a - \frac{c}{2} \right) \right\} = wc \frac{b}{l} - wx + w \left( a - \frac{c}{2} \right)$$

$$\text{or,} \quad w \left( \frac{cb}{l} + a - x - \frac{c}{2} \right)$$

which equals zero when  $x = \frac{b}{l} + a - \frac{c}{2}$ .

For the remainder of the length to the right-hand support the shearing force is numerically equal to  $R_2$ , or algebraically to  $R_1 - wc$ , *i.e.*—

$$F = w \left( \frac{cb}{l} - c \right) \quad \text{or} \quad wc \left( \frac{b-l}{l} \right) \quad \text{or} \quad -wc \frac{a}{l}$$

The bending moment ( $M$ ) at a section distant  $x$  from the left-hand end to the beginning of the load, *i.e.* if  $x$  is less than  $a - \frac{c}{2}$ , estimating moments on the left of the section, is—

$$M_x = R_1 \cdot x = wc \frac{b}{l} \cdot x \quad (\text{a straight line})$$

Over the loaded portion, *i.e.* if  $x$  is greater than  $a - \frac{c}{2}$  and less than  $a + \frac{c}{2}$ ,

$$\begin{aligned} M_x &= R_1 \cdot x - \left\{ x - \left( a - \frac{c}{2} \right) \right\} \times w \cdot \frac{1}{2} \left\{ x - \left( a - \frac{c}{2} \right) \right\} \\ &= wc \frac{b}{l} x - \frac{w}{2} \left( x - a + \frac{c}{2} \right)^2 \end{aligned}$$

The first term is represented by the left-hand dotted straight line, and the second by the distance between the curve and the straight line, and the value  $M_x$  by the vertical ordinate of the shaded diagram.

To the right of the load, *i.e.* when  $x$  is greater than  $a + \frac{c}{2}$ , estimating to the left—

$$\begin{aligned} M_x &= R_1 \cdot x - wc(x - a) \\ &= wc \frac{b}{l} \cdot x - wc(x - a) \end{aligned}$$

$$\begin{aligned} \text{or,} \quad M_x &= wca - wcx \left( 1 - \frac{b}{l} \right) \quad \text{or} \quad wca - wc \cdot \frac{x}{l} \cdot a = wc \cdot \frac{a}{l} (l - x) \\ &= R_2 (l - x) \quad (\text{a straight line}) \end{aligned}$$



which is much more simply found by taking the moments of the sole force  $R_2$  to the right of any section in the range considered.

Fig. 67 represents a beam symmetrically placed over supports of

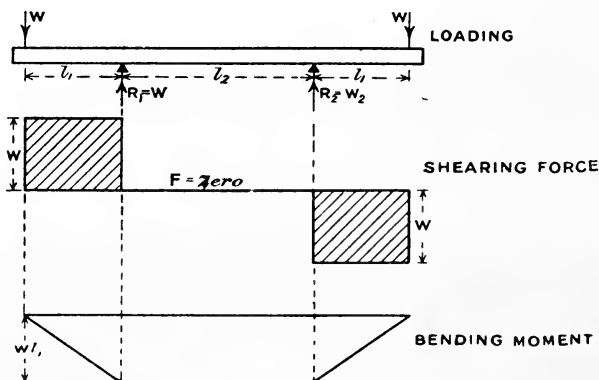

FIG. 67.

shorter span,  $l_2$ , than the length of the beam,  $l_2 + 2l_1$ , and carrying equal end loads. Between the supports the shearing force is zero and the bending moment is constant.

Fig. 68 shows a beam of length  $l_2 + 2l_1$ , with a uniformly spread load

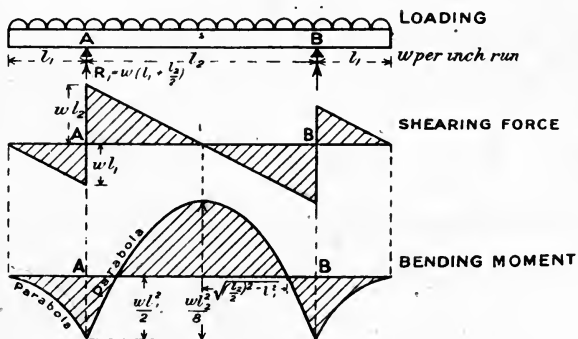

FIG. 68.

placed on supports  $l_2$  apart and overhanging them by a length  $l_1$  at each end. The bending moment at the supports is—

$$M = wl_1 \times \frac{l_1}{2} = \frac{wl_1^2}{2}$$

Within the span at a distance  $x$  from either support the bending moment is—

$$\begin{aligned} M_x &= w(l_1 + x) \times \frac{l_1 + x}{2} - R_1 x \\ &= \frac{w}{2}(l_1 + x)^2 - wx \left( l_1 + \frac{l_2}{2} \right) \\ &= \frac{w}{2} l_1^2 - \frac{w}{2} (l_2 x - x^2) \end{aligned}$$

the first term of which is the bending moment at the supports, and the second is bending moment for a uniformly loaded span of length  $l_2$  (see Fig. 65). The two terms are of opposite sign, and, provided  $l_2$  is long enough, the bending moment will be zero and change sign at two points within the span, viz. when  $M_x = 0$ , or—

$$\begin{aligned} \frac{w}{2} \cdot l_1^2 - \frac{w}{2} x(l_2 - x) &= 0 \\ x^2 - l_2 x + l_1^2 &= 0 \\ x &= \frac{l_2}{2} \pm \sqrt{\left(\frac{l_2}{2}\right)^2 - l_1^2} \end{aligned}$$

*i.e.* at two points distant  $\sqrt{\left\{\left(\frac{l_2}{2}\right)^2 - l_1^2\right\}}$  on either side of mid span;

the two points are coincident (at mid span) if  $l_2 = 2l_1$ , and do not exist if  $l_2$  is less than  $2l_1$ , when the bending moment does not change sign.

*Points of Contraflexure.*—Bending moments of opposite sign evidently tend to produce bending of opposite curvature. In a continuous curve of bending moments change of sign involves passing through a zero value of bending moment, and this point of zero bending moment and change of sign is called a point of inflection or contraflexure, or a virtual hinge. The positions of the points of contraflexure for Fig. 68 have just been determined above from the equation  $M_x = 0$ .

**58. Bending Moments from Link or Funicular Polygon.**—The vertical breadths of a funicular or link polygon for a system of vertical forces on a horizontal beam represent to scale the bending moments at the corresponding sections. This is illustrated in Fig. 69, where the link polygon has been drawn on a horizontal base by making the vector  $fo$  in the vector polygon horizontal, *i.e.* by choosing a pole  $o$  in the same horizontal line as the point  $f$ , which divides the load-line  $abcde$  in the ratio of the supporting forces. The proof of the statement follows easily from the similarity of triangles formed by producing the sides of the link polygon, to the corresponding triangles in the vector polygon,<sup>1</sup> and the scale of bending moment is  $p \cdot q \cdot h$  lb.-inches to 1 inch where the scale of force is  $p$  lbs. to 1 inch, of distance  $q$  inches to 1, and the pole distance  $fo$  measures  $h$  inches. It is not necessary to draw the diagram on a horizontal base, but the distance  $h$  must be estimated

<sup>1</sup> For proof see the author's "Mechanics for Engineers," chap. x. (Longmans.) Or "Theory of Structures," where bending moments by graphical methods are more fully treated.

horizontally, and the ordinates of bending moment must be measured vertically.

The shearing-force diagram is shown projected from the vertical load-line of the vector polygon.

The same method of drawing the bending-moment diagram to as close approximation as is desired is applicable to loads distributed

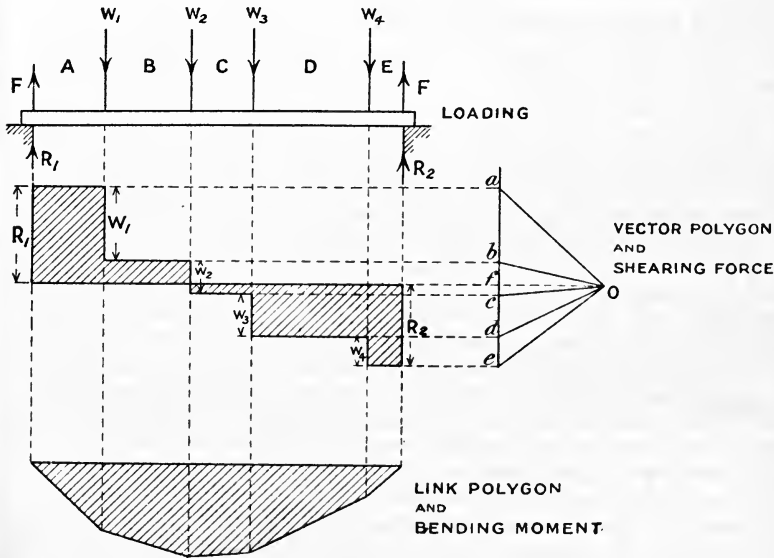

FIG. 69.

either uniformly or otherwise by dividing the load into a number of sections along the length of the beam, and treating each part as a load concentrated at its centre of gravity. The resulting funicular polygon will be a figure with straight sides, and the curve of bending moments is the *inscribed* (not *circumscribed*) curve touching the sides of the polygon.

**59. Relation between Bending Moment and Shearing Force.—**

Consider a small length  $\delta x$  of a beam (Fig. 70) carrying a continuous distributed load  $w$  per unit of length, where  $w$  is not necessarily constant, but  $\delta x$  is sufficiently small to take  $w$  as constant over that length. Let  $F$  and  $F + \delta F$  be the shearing forces,  $M$  and  $M + \delta M$  the bending moments at either end of the length  $\delta x$  as shown in Fig. 70.

Equating upward and downward vertical forces on length  $\delta x$ —

$$F + \delta F = F + w\delta x$$

$$\delta F = w \cdot \delta x$$

$$\frac{dF}{dx} = w \quad . . . . . (1)$$

and

*i.e.* the rate of change of shearing force (represented by the slope of the shearing-force curve) is numerically equal to the intensity of loading.

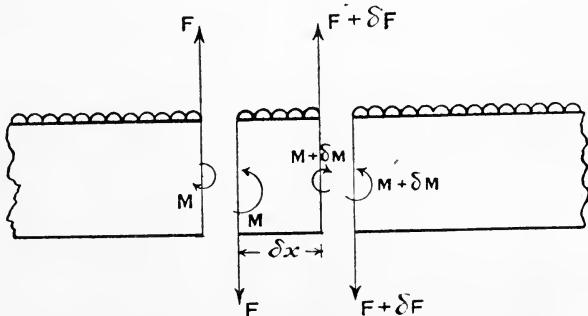

FIG. 70.

Or integrating between two sections  $x - x_0$  apart—

$$F - F_0 \text{ (the total change in shearing force)} = \int_{x_0}^x w \cdot dx$$

or,

$$F = F_0 + \int_{x_0}^x w \cdot dx$$

taking appropriate signs for each term.

These relations for  $w = \text{constant}$  are illustrated in the shearing-force diagrams of Figs. 61, 65, and 68.

Equating moments of opposite kinds, of all external forces on the piece of length  $\delta x$ , about any point in the left-hand section—

$$M + (F + \delta F)\delta x - w \cdot \delta x \times \frac{\delta x}{2} = M + \delta M$$

$$\delta M = F\delta x, \text{ to the first order of small quantities}$$

and

$$\frac{dM}{dx} = F \dots \dots \dots (2)$$

*i.e.* the rate of change of bending moment is equal to the shearing force.

Hence, integrating, the total change of bending moment from  $x_0$  to  $x$  is  $\int_{x_0}^x F dx$ , which is proportional to the area of the shearing-force diagram between the ordinates at  $x_0$  and  $x$ . For example, this area is zero between the ends of the beam in Figs. 63 to 69 inclusive, there being as much area above the base-line as below it.

The relation (2) indicates that the ordinates of the shearing-force diagram are proportional to the slopes or gradients of the bending-moment curve. Where the shearing force passes through a zero value and changes sign, the value of the bending moment is a (mathematical) maximum or minimum, a fact which often forms a convenient method of determining the greatest bending moment to which a beam is subjected, as in Figs. 65, 66, and 68. In Fig. 66 the section at which

the shearing force is zero evidently divides the length  $c$  in the ratio  $\frac{R_1}{R_2}$ ; or, using the expression given in Art. 57,  $F$  is zero at a distance—

$$c \frac{b}{l} + a - \frac{c}{2}$$

from the left support. At this point the bending moment is a maximum, and its value is easily calculated.

*Signs.*—It is to be noted that  $x$  being taken positive to the right and  $w$  positive downwards,  $F$  has been chosen as positive in (1) when its action is upwards to the left and downwards to the right of the section considered. Hence, taking account of sign forces being reckoned positive downwards, the shearing force is equal to the downward internal force exerted to the right of any section, or to the algebraic sum of the *upward external forces to the right* of the section, or to the algebraic sum of the *downward external forces to the left* of the section. Also  $M$  has been chosen as positive in (2) when its action is clockwise on the portion of the beam to the left of the section and contra-clockwise to the right of the section. Hence the bending moment is equal to the *clockwise moment of the external forces to the right* of a section or to the *contra-clockwise moment of the external forces to the left* of the section. It is evident that a positive bending moment will produce convexity upwards and a negative bending moment convexity downwards.

*Concentrated Loads.*—In the case of loads concentrated (more or less) at fixed points along the span, the curve of shearing force (see Figs. 60, 62, 63, 64, 67, and 69) is discontinuous, and so also is the gradient of the bending-moment curve. Between the points of loading, however, the above relations hold, and the section at which the shearing-force curve crosses the base-line is a section having a maximum bending moment (see Figs. 63, 67, and 69). A concentrated load in practice is usually a load distributed (but not necessarily uniformly) over a very short distance, and the vertical lines shown in the shear diagrams at the loads should really be slightly inclined to the vertical, there being at any given section only *one* value of the shearing force.

**EXAMPLE 1.**—A beam 20 feet long rests on supports at each end and carries a load of  $\frac{1}{2}$  ton per foot run, and an additional load of  $1\frac{1}{2}$  ton per foot run for 12 feet from the left-hand end. Find the position and magnitude of the maximum bending moment, and draw the diagrams of shearing force and bending moment.

The loading is indicated at the top of Fig. 71 at ACB.

The reactions due to the  $\frac{1}{2}$  ton per foot are 5 tons at A and B. For the  $1\frac{1}{2}$  ton per foot load, the centre of gravity of which is 6 feet from A—

$$\left. \begin{array}{l} \text{(reaction at B)} \times 20 = 18 \times 6 \\ \text{reaction at B} = 5.4 \text{ tons} \end{array} \right\} \text{due to second load}$$

hence reaction at A = 18 - 5.4 = 12.6 tons

The shearing-force diagrams for the two loads have been set off separately on opposite sides of a horizontal line, and the resultant diagram is shown shaded.

The bending moment is a maximum where the shear force is zero, as shown at D. The distance from the left support is perhaps most easily found from the fact that the shearing force at the left support is 17.6 tons, and falls off at the rate of 2 tons per foot run, and therefore reaches zero at a distance—

$$\frac{17.6}{2} \text{ or } 8.8 \text{ feet from the left-hand support}$$

The bending moment at 8.8 feet is—

$$17.6 \times 8.8 - 8.8 \times 2 \times \frac{8.8}{2} = 77.44 \text{ tons-feet}$$

The bending-moment diagrams for the two loads have been drawn on opposite sides of the same base-line in Fig. 71, giving a combined diagram for the two, by vertical measurements between the boundaries.

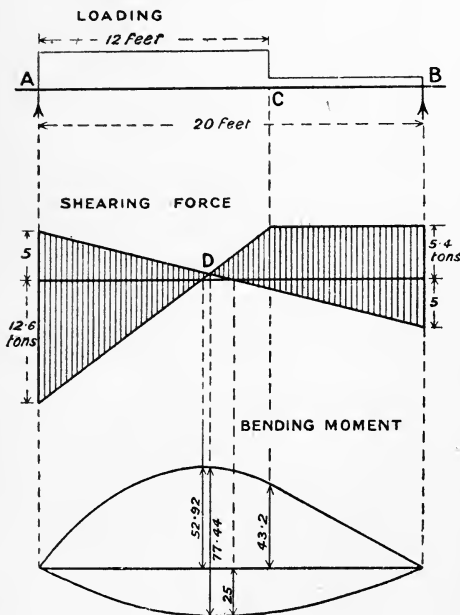

FIG. 71.

At C the ordinate of this curve is—

$$5.4 \times 8 = 43.2 \text{ tons-feet}$$

and to the right of C it varies directly as the distance from B—the curve being a straight line.

EXAMPLE 2.—A horizontal beam, AB, 24 feet long, is hinged at A, and rests on a support at C, 16 feet from A, and carries a distributed load of 1 ton per foot run, and an additional load of 32 tons at B. Find the reactions, shearing forces, and bending moments. If the load at B is reduced to 8 tons, what difference will it make?

Let  $R_c$  be the upward reaction at support C.

For the  $\frac{1}{2}$  ton per foot load alone the maximum bending moment is at the middle of the span, and is—

$$5 \times 10 - \frac{1}{2} \times 10 \times 5 = 25 \text{ tons-feet}$$

For the  $1\frac{1}{2}$  ton per foot load alone the maximum occurs where the shearing force due to that load would be zero, a distance from A which is given by—

$$12.6 \div 1.5 = 8.4 \text{ feet}$$

The maximum ordinate of this curve is then—

$$12.6 \times 8.4 - 8.4 \times 1\frac{1}{2} \times \frac{8.4}{2} = 52.92 \text{ tons-feet}$$

Taking moments about A (Fig. 72)—

$$16 \cdot R_C = (32 \times 24) + (24 \times 12) = 1056$$

$$R_C = 66 \text{ tons}$$

If the upward reaction at A =  $R_A$ —

$$R_A = 24 + 32 - 66 = -10 \text{ tons}$$

or 10 tons *downward*.

The shearing-force diagram is shown in Fig. 72. From B, where the shearing force is 32 tons, it increases uniformly by 8 to C, where it

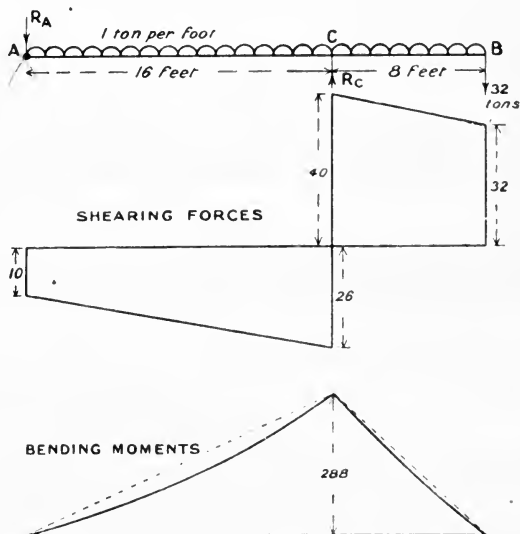

FIG. 72.

is reduced by 66 tons to 26 of opposite sign. From C to A the total change at a uniform rate is 16 tons, giving a value 10 at A.

The bending moment at C is—

$$(32 \times 8) + (8 \times 4) = 288 \text{ tons-feet}$$

This falls to zero at A and B, and does not reach a maximum value, in the mathematical sense, in either range. The bending moment 4 feet from B is—

$$(32 \times 4) + (4 \times 2) = 136 \text{ tons-feet}$$

Midway between A and C it is—

$$(10 \times 8) + (8 \times 4) = 112 \text{ tons-feet}$$

The full diagram is shown in Fig. 72.

Treating the problem with only 8 tons load at B—

$$16R_C = (24 \times 8) + (12 \times 24) = 192 + 288 = 480$$

$$R_C = 30 \text{ tons}$$

$$\text{Total load} = 24 + 8 = 32 \text{ tons}$$

$$R_A = 2 \text{ tons upward}$$

The diagrams of shearing force and bending moment are shown in Fig. 73. The shearing force at B is 8 tons, and increases by a further 8 tons to 16 at C, where it decreases by 30 tons to 14 of opposite sign. From C to A it changes by 16 to 2 tons at A, changing sign and passing through zero between C and A.

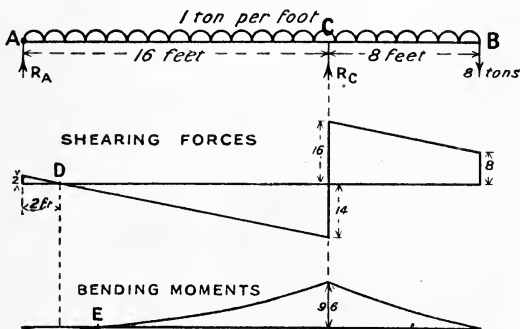

FIG. 73.

The section which has a (mathematical) maximum bending moment between A and C is that for which the shearing force is zero, and since the shear is 2 tons at A and falls off at 1 ton per foot run, the zero value will be, at a section D, 2 feet from A.

The bending moment at C is—

$$(8 \times 8) + (8 \times 4) = 96 \text{ tons-feet}$$

At 4 feet from B it is—

$$(8 \times 4) + (4 \times 2) = 40 \text{ tons-feet}$$

Between A and C, at a distance  $x$  from A, it is—

$$x \times \frac{x}{2} - 2x \quad \text{or} \quad x \left( \frac{x}{2} - 2 \right)$$

which is zero, for  $x = 4$  feet, *i.e.* 4 feet from A, where a point of contraflexure E occurs. This distance might have been inferred otherwise, for it is evidently twice that of the point D from A.

Finally,  $M_D = 2 \times 1 - 2 \times 2 = -2$  tons-feet

**EXAMPLE 3.**—A beam simply supported at each end has a span of 20 feet. The load is distributed and is at the rate of 1 ton per foot run at the left support, and 4 tons per foot run at the right-hand support, and varies uniformly from one rate to the other along the span. Find the position and amount of the maximum bending moment.

The load may conveniently be divided into a uniformly spread load of 1 ton per foot run, and a second varying from zero at the left to 3 tons per foot run at the right. The first will evidently cause a reaction of 10 tons at each support. The second load has an average intensity



of 1.5 ton per foot run, or is 30 tons in all; its centre of gravity will be  $\frac{2}{3}$  of the span from the left end, so that the right-hand reaction due to this load will be  $\frac{2}{3}$  of 30 tons, or 20 tons, and the left-hand one will be 10 tons.

The total reactions are therefore 20 tons and 30 tons at the left- and right-hand ends respectively.

The load per foot at a distance  $x$  feet from the left support is—

$$1 + \frac{3}{20}x \text{ tons per foot}$$

since it increases  $\frac{3}{20}$  ton per foot per foot.

The average over the length  $x$  feet is—

$$\frac{1}{2}(1 + 1 + \frac{3}{20}x) \text{ or } 1 + \frac{3}{40}x \text{ tons per foot}$$

and the total load on  $x$  feet is—

$$x(1 + \frac{3}{40}x)$$

The bending moment is a maximum when the shearing force is zero, *i.e.* at the section where the load carried to the left of it is equal to the left-hand reaction of 20 tons.

For this point the shearing force—

$$F = 20 - x\left(1 + \frac{3x}{40}\right) = 0$$

$$3x^2 + 40x - 800 = 0$$

$$x = 10.96 \text{ feet} = 10 \text{ feet } 11.5 \text{ inches}$$

The bending moment at a distance  $x$  feet from the support is—

$$20x - x \times \frac{x}{2} - \frac{3x^2}{40} \times \frac{1}{3}x$$

and when  $x = 10.96$  feet—

$$M = 219 - 60 - 33 = 126 \text{ tons-feet}$$

The shearing-force and bending-moment curves may be plotted from the two above expressions for  $F$  and  $M$ .

**60. Theory of Elastic Bending.**—The relations existing between the straining action, the dimensions, the stresses, strains, elasticity, and curvature of a beam are under certain simple assumptions very easily established for the case of *simple bending*, *i.e.* flexure by pure couples applied to a beam without shearing force.

Most of the same simple relations may generally be used as close approximations in cases of flexure which are not "simple," but which are of far more common occurrence, the strains involved from the shearing force being negligible. In such cases, the justification of the "simple theory of bending" must be the agreement of its conclusions with direct bending experiments, and with those of more complex but more exact theory of elastic bending.

**61. Simple Bending.**—A straight bar of homogeneous material subjected only to equal and opposite couples at its ends has a uniform

bending moment throughout its length, and if there is no shearing force, is said to suffer simple bending. Such a straining action is illustrated in Fig. 67 for the beam between its two points of support. The beam will be supposed to be of the same cross-section throughout its length, and symmetrical about a central longitudinal plane, in and parallel to which bending takes place. In Fig. 74, central longitudinal sections before and after bending and a transverse section are shown, the cross-section being symmetrical about an axis  $YY$ .

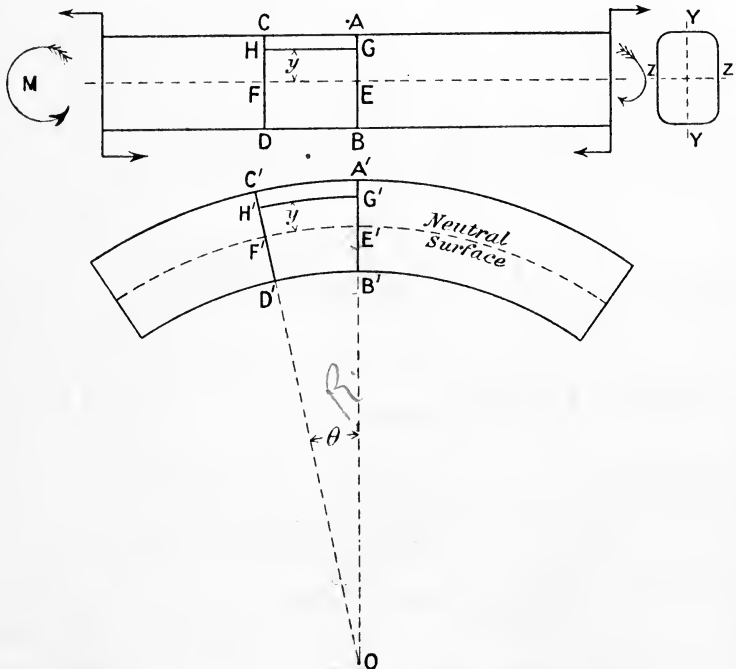

FIG. 74.—Simple bending.

It will be assumed that transverse plane sections of the beam remain plane and normal to longitudinal fibres after bending, which seems reasonable since the straining action is the same on every section. The assumption is called Bernoulli's.

Consider any two transverse sections  $AB$  and  $CD$  very close together. After bending, as shown at  $A'B'$  and  $C'D'$ , they will not be parallel, the layer of material at  $AC$  being extended to  $A'C'$ , and that at  $BD$  being pressed to  $B'D'$ . The line  $EF$  represents the layer of material which is neither stretched nor shortened during bending. This surface  $EF$  suffers no longitudinal strain, and is called the *neutral surface*. Its line of intersection  $ZZ$  with a transverse section is called the *neutral axis* of that section.

Suppose the section A'B' and C'D' produced to intersect, at an angle  $\theta$  (radians), in a line perpendicular to the figure and represented by O, and that the radius of curvature OE' of the neutral surface E'F' about O is R. Let  $y$  be the height (E'G') of any layer (H'G') of material originally parallel to the neutral surface FE. Then—

$$\frac{H'G'}{E'F'} = \frac{(R + y)\theta}{R\theta} = \frac{R + y}{R}$$

and the strain at the layer H'G' is—

$$e = \frac{H'G' - HG}{HG} = \frac{H'G' - E'F'}{E'F'} = \frac{(R + y)\theta - R\theta}{R\theta} = \frac{y}{R}$$

The longitudinal tensile-stress intensity  $p$  at a height  $y$  from the neutral surface, provided the limit of elasticity has not been exceeded, is therefore—

$$p = E \cdot e = E \cdot \frac{y}{R} \dots \dots \dots (1)$$

where E is Young's modulus, provided that the layers of material behave under longitudinal stress as if free and are not hindered by the surrounding material, which has not the same intensity of stress. The intensity of compressive stress will be the same at an equal distance  $y$  on the opposite side of the neutral surface, provided E is the same in compression as in tension.

The intensity of direct longitudinal stress  $p$  at every point in the cross-section is then proportional to its distance from the neutral axis; its value at unit distance (*i.e.* at  $y = 1$ ) is  $\frac{E}{R}$ , and it reaches a maximum value at the boundary furthest from the neutral surface. The variation in intensity of longitudinal stress is as shown in

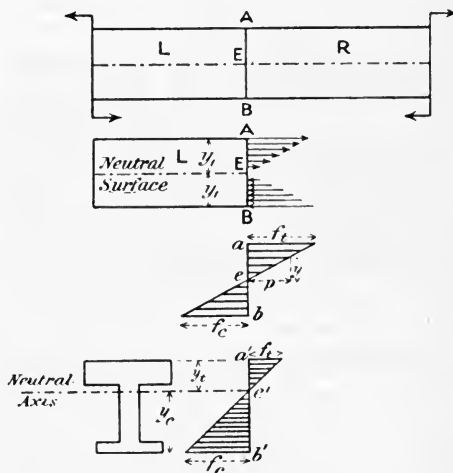

FIG. 75.

Fig. 75, where the arrow-heads denote the direction of the force exerted by the portion R on the portion L at the section AB. Since the stresses on opposite sides of the neutral surface are of opposite sign or kind, they may be represented as at *acb*.

**62. Position of the Neutral Axis.**—The beam has been supposed subjected to pure couples only, and therefore the portion, say, to the left of the section AB (Figs. 74 and 75), being in equilibrium under one

externally applied couple and the forces acting across AB, these forces must exert a couple balancing the external one in the plane of bending. The (vertical) shearing force being *nil*, the internal forces exerted across AB are wholly horizontal (or longitudinal), and since they form a couple the total tensile forces must balance the compressive ones, *i.e.* the algebraic sum of the horizontal internal forces must, like the external ones, be zero. Putting this statement in symbols, we can find the

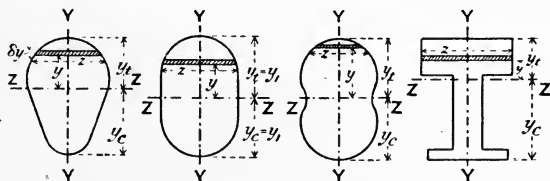

FIG. 76.

position of the neutral axis. The cross-section of the beam in Fig. 74 is symmetrical about a horizontal axis, but this is not necessary to the argument. Taking any other cross-sections symmetrical about the plane of bending YY, as in Fig. 76, let  $\delta a$  or  $z \cdot \delta y$  be an elementary strip of its area parallel to the neutral axis ZZ,  $z$  being the (variable) width of the section. Then, the total horizontal force being zero—

$$\Sigma(p \cdot \delta a) = 0 \quad \text{or} \quad \Sigma(p \cdot z \cdot \delta y) = 0$$

and since by (1), Art. 61—

$$p = \frac{E}{R} \cdot y$$

$$\frac{E}{R} \Sigma(y \cdot \delta a) = 0 \quad \text{or} \quad \frac{E}{R} \Sigma(y \cdot z \delta y) = 0 \quad \dots (2)$$

the quantity  $\Sigma(y \cdot \delta a)$  or  $\Sigma(y \cdot z \cdot \delta y)$  represents the total moment of the area of section about the neutral axis, and this can only be zero if the axis passes through the centre of gravity or centroid of the section.

The use of the value  $\frac{E}{R} \cdot y$  for  $p$ , in all parts of the cross-section involves the assumption that the value of  $E$  is the same in compression as in tension, an assumption justified by experiment within the limits of elasticity.

*Assumptions made in the Theory of Simple Bending.*—It may be well to recall the assumptions made in the above theory of “simple bending,” under the conditions stated—

(1) That plane transverse sections remain plane and normal after bending.

(2) That the material is homogeneous, isotropic, and obeys Hooke’s law, and the limits of elasticity are not exceeded.

(3) That every layer of material is free to expand or contract longitudinally and laterally under stress, as if separate from other layers.

Otherwise,  $E$  in the relation (1), Art. 61, would not be Young's modulus, but some modified elastic constant (see Art. 21); but the relation would otherwise remain unaltered.

(4) That the modulus of direct elasticity has the same value in compression as for tensile strains.

**63. Value of the Moment of Resistance.**—Having found the intensity of longitudinal stress ( $p = \frac{E}{R} \cdot y$ ) at any distance  $y$  from the neutral axis, and knowing that these longitudinal internal forces form a couple equal to the bending moment at every section, it remains to express the value of the couple, which is called the moment of resistance (see Art. 56), in terms of the dimensions of the cross-section, and the intensity of stress produced.

Using Fig. 76, as in the previous article, the elementary area of cross-section, at a distance  $y$  from the neutral axis, is  $\delta a$ , or  $z \cdot \delta y$ , and the intensity of stress upon it is—

$$p = \frac{E}{R} y$$

The total stress on the elementary area is—

$$p \cdot \delta a \text{ or } p \cdot z \cdot \delta y$$

and the moment of this stress is—

$$p \cdot y \cdot \delta a \text{ or } p \cdot z \cdot y \cdot \delta y$$

and the total moment throughout the section is—

$$M = \Sigma(p \cdot y \cdot \delta a) \text{ or } M = \Sigma(p \cdot z \cdot y \cdot \delta y)$$

and putting

$$p = \frac{E}{R} \cdot y \text{ (Art. 61)}$$

$$M = \frac{E}{R} \Sigma(y^2 \cdot \delta a) \text{ or } \frac{E}{R} \Sigma(zy^2 \delta y) \quad . \quad (3)$$

The sum  $\Sigma(y^2 \delta a)$ , or  $\Sigma(zy^2 \delta y)$ , represents the limiting value of the sum of the products of elements of area, multiplied by the squares of their distances from the axis, when the elements of area are diminished indefinitely, and is usually called the Moment of Inertia of the area of the section about the axis. The values of the moments of inertia for various sections are dealt with in Arts. 66–68. If we denote the moment of inertia of the area of the section by  $I$ , so that—

$$\Sigma(y^2 \delta a) = \Sigma(zy^2 \delta y) = I$$

the formula (3) becomes—

$$M = \frac{E}{R} I \text{ or } \frac{M}{I} = \frac{E}{R} \quad . \quad . \quad . \quad (4)$$

and since by (1), Art. 61,  $\frac{E}{R} = \frac{p}{y}$  (the stress intensity at unit distance from the neutral axis), we have—

$$\frac{p}{y} = \frac{M}{I} = \frac{E}{R} \dots \dots \dots (5)$$

These relations are important and should be remembered. If we put this relation in the form—

$$p = \frac{M}{I} \cdot y \quad \text{or} \quad \frac{E}{R} \cdot y$$

we have the intensity of longitudinal stress at a distance  $y$  from the neutral axis, in terms of the bending moment and dimensions ( $I$ ) of cross-section, or in terms of the radius of curvature and an elastic constant for the material. The extreme values of  $p$ , tensile and compressive, occur at the layers of material most remote from the neutral axis. Thus, in Figs. 75 and 76, if the extreme layers on the tension and compression sides are denoted by  $y_t$  and  $y_c$  respectively,  $f_t$  and  $f_c$  being the extreme intensities of tensile and compressive stress respectively—

$$\frac{p}{y} = \frac{f_t}{y_t} = \frac{f_c}{y_c} = \frac{M}{I} = \frac{E}{R}$$

or,

$$f_t = M \cdot \frac{y_t}{I} \quad f_c = M \cdot \frac{y_c}{I}$$

or,

$$M = f_t \cdot \frac{I}{y_t} = f_c \cdot \frac{I}{y_c} \dots \dots \dots (6)$$

The variation of intensity of stress for an unsymmetrical section is shown in Fig. 75 at  $a'e'b'$ .

For sections which are symmetrical about the neutral axis, the distances  $y_t$  and  $y_c$  will be equal, being each half the depth of the section. If we denote the half depth by  $y_1$ , and the equal intensities of extreme or skin stress by  $f_1$ , so that—

$$M = f_1 \frac{I}{y_1}$$

the quantity  $\frac{I}{y_1}$  is called the modulus of section, and is usually denoted by the letter  $Z$ , so that—

$$M = fZ \quad \text{or} \quad f = \frac{M}{Z} \dots \dots \dots (7)$$

the moment of resistance ( $M$ ) being proportional to the greatest intensity of stress reached and to the modulus of section.

In the less usual case of unsymmetrical sections, the modulus of section would have the two values—

$$\frac{I}{y_t} \quad \text{and} \quad \frac{I}{y_c}$$

which may be denoted by  $Z_t$  and  $Z_c$ , so that the relation (6) becomes

$$M = f_t Z_t = f_c Z_c \dots \dots \dots (8)$$

**64. Ordinary Bending.**—The case of *simple bending*, dealt with in the previous articles, refers only to bending where shearing force is absent, but such instances are not usual, and generally bending action is accompanied by shearing force, which produces a (vertical) shear stress across transverse sections of the beam (see Figs. 59 to 66, etc.). In such cases the forces across any section at which the shearing force is not zero have not only to balance a couple, but also the shearing force at the section, and, therefore, at points in the cross-section there will be tangential as well as normal longitudinal stresses. The approximate distribution of this tangential stress is dealt with in Art. 71, and the deflection due to shearing in Art. 96. When the shearing stresses are not zero, the longitudinal stress at any point in the cross-section is evidently not the principal stress (Arts. 14 and 73) at that point, and the strain is not of the simple character assumed in Art. 61 and Fig. 74, and there is then no reason to assume that plane sections remain plane.<sup>1</sup> St. Venant, a celebrated French elastician, has investigated the flexure of a beam assuming freedom of every layer or fibre to contract or expand laterally, under longitudinal tension or compression, but without the assumption that plane sections remain plane after bending. His conclusion is that Bernoulli's assumption and equations of the type (5), Art. 63, only hold exactly when the bending moment from point to point follows a straight line law, *i.e.* when the shearing force is constant. For the more exact elastic theory of St. Venant, applicable to other cases, the reader is referred to Todhunter, and Pearson's "History of Theory of Elasticity," vol. ii. pt. 1, pp. 53-69.

For most practical cases the theory of "Simple Bending" (Arts. 61, 62, and 63) is quite sufficient, and gives results which enable the engineer to design beams and structures, and calculate their stresses and strains with a considerable degree of approximation. It may be noticed that in many cases of continuous loading the *greatest* bending moment occurs as a mathematical maximum at the sections for which the shearing force is zero (Art. 59, and Figs. 63 to 69), and for which the conditions correspond with those for *simple* flexure; in numerous cases where the section of the beam is uniform throughout its length, the maximum longitudinal stress occurs at the section of maximum bending moment; the usefulness of the *simple* theory in such a case is evident. Further, it often happens that where the shearing force is considerable the bending moment is small, and in such cases the intensity of shear stress can be calculated sufficiently nearly by the method of Art. 71.

In this book the usual engineer's practice of using the simple beam theory will be followed, a few modifications in the strains and stresses in certain cases will be mentioned.

**65. Summary of the Simple Theory of Bending.**—At any transverse section of a horizontal beam carrying vertical loads, from the three usual conditions of equilibrium, we have—

(1) The total vertical components of stresses across a vertical section are together equal to the algebraic sum of the external forces to either side of the section, *i.e.* to the shearing force  $F$ .

<sup>1</sup> See footnote to Art. 71.

(2) The algebraic total horizontal force is zero.

(3) The total moment of resistance of the horizontal forces across the section is equal to the algebraic sum of the moments of the external forces to either side of the section, *i.e.* to the bending moment  $M$ .

If plane sections remain plane, longitudinal strain is proportional to the distance from the neutral axis,  $e$  being equal to  $\frac{y}{R}$ ; hence, longitudinal stress intensity at any point in a cross-section is proportional to the same distance, or—

$$p \propto y \quad \text{and} \quad p = \frac{E}{R} \cdot y$$

Summing the moments of longitudinal stress—

$$M = \frac{E}{R} \cdot I = \frac{pI}{y}$$

or,

$$\frac{p}{y} = \frac{M}{I} = \frac{E}{R} = \frac{f_1}{y_1}$$

where  $f_1$  and  $y_1$  are the intensity of skin stress, and the vertical distance from the neutral axis to the outer boundary of the section respectively.

In applying these relations to numerical examples, it should be remembered that the units must be consistent; as cross-sections are usually stated in inches, and stresses in pounds or tons per square inch, it is well to take the bending moment, or moment of resistance, in lb.-inches or ton-inches.

EXAMPLE 1.—To what radius of curvature may a steel beam of symmetrical section, 12 inches deep, be bent without the skin stress exceeding 5 tons per square inch? ( $E = 13,500$  tons per square inch.)

Since

$$\frac{E}{R} = \frac{f_1}{y_1} \quad \therefore R = \frac{Ey_1}{f_1}$$

$y_1$  being the half depth, which is 6 inches.

Hence

$$R = \frac{13,500 \times 6}{5} = 16,200 \text{ inches, or } 1350 \text{ feet}$$

EXAMPLE 2.—If the elastic limit is not exceeded, find the stress induced in a strip of spring steel,  $\frac{1}{20}$  inch thick, by bending it round a drum 2.5 feet diameter? ( $E = 13,500$  tons per square inch.)

$$f_1 = \frac{Ey_1}{R}$$

The greatest value of  $y$  is  $\frac{1}{2} \times \frac{1}{20} = \frac{1}{40}$  inch. The radius being 15 inches—

$$f_1 = \frac{13,500 \times \frac{1}{40}}{15} = 22.5 \text{ tons per square inch}$$

EXAMPLE 3.—The moment of inertia of a symmetrical section being 2654 inch units, and its depth 24 inches, find the longest span



over which, when simply supported, a beam could carry a uniformly distributed load of 1.2 ton per foot run, without the stress exceeding 7.5 tons per square inch.

If  $l$  = span in inches, the load per inch run being  $\frac{1.2}{12}$ , or 0.1 ton, the maximum bending moment which occurs at mid-span is—

$$M = \frac{1}{8} \times 0.1 \times l^2 \text{ (see Fig. 65)}$$

And since  $M = f_1 \cdot \frac{I}{y_1}$ , and  $y_1$  the half depth is 12 inches

$$\frac{1}{8} \times \frac{1}{10} \times l^2 = 7.5 \times \frac{2654}{12}$$

$$l^2 = \frac{80 \times 7.5 \times 2654}{12} = 132,700$$

$$l = 364 \text{ inches, or 30 feet 4 inches}$$

#### EXAMPLES IV.

1. A cantilever 12 feet long carries loads of 3, 7, 4, and 6 tons at distances 0, 2, 5, and 8 feet respectively from the free end. Find the bending moment and shearing force at the fixed end and at the middle section of the beam.

2. A cantilever 10 feet long weighs 25 lbs. per foot run, and carries a load of 200 lbs. 3 feet from the free end. Find the bending moment at the support, and draw the diagrams of shearing force and bending moment.

3. A beam rests on supports 16 feet apart, and carries, including its own weight, a load of 2 tons (total) uniformly distributed over its whole length and concentrated loads of  $1\frac{1}{2}$  ton and  $\frac{1}{2}$  ton, 5 feet and 9 feet respectively from the left support. Find the bending moment 4 feet from the left-hand support, and the position and magnitude of the maximum bending moment.

4. Where does the maximum bending moment occur in a beam of 24 feet span carrying a load of 10 tons uniformly spread over its whole length, and a further load of 12 tons uniformly spread over 8 feet to the right from a point 6 feet from the left support? What is the amount of the maximum bending moment, and what is the bending moment at mid-span?

5. A beam of span  $l$  feet carries a distributed load, which increases uniformly from zero at the left-hand support to a maximum  $w$  tons per foot at the right-hand support. Find the distance from the left-hand support of the section which has a maximum bending moment and the amount of that bending moment. Obtain numerical values when  $l = 18$  feet and  $w = 2$  tons per foot run.

6. A horizontal beam AB 30 feet long is supported at A and at C 20 feet from A, and carries a load of 7 tons at B and one of 10 tons midway between A and C. Draw the diagrams of bending moment and find the point of contraflexure.

7. Find the point of contraflexure in the previous example if there is an additional distributed load of  $\frac{1}{4}$  ton per foot run from A to C.

8. A girder 40 feet long is supported at 8 feet from each end, and carries a load of 1 ton per foot run throughout its length. Find the bending moment at the supports and at mid-span. Where are the points of contraflexure? Sketch the curve of bending moments.

9. A beam of length  $l$  carries an evenly distributed load and rests on two supports. How far from the ends must the supports be placed if the greatest

bending moment to which the beam is subjected is to be as small as possible? Where are the points of contraflexure?

10. A beam 18 feet long rests on two supports 10 feet apart, overhanging the left-hand one by 5 feet. It carries a load of 5 tons at the left-hand end, 7 tons midway between the supports, and 3 tons at the right-hand end. Find the bending moment at the middle section of the beam and at mid-span, and find the points of contraflexure.

11. If the beam in the previous example carries an additional load of 1 ton per foot run between the supports, find the bending moment at mid-span and the positions of the points of contraflexure.

12. Find the greatest intensity of direct stress arising from a bending moment of 90 tons-inches on a symmetrical section 8 inches deep, the moment of inertia being 75 inch units.

13. Calculate the moment of resistance of a beam section 10 inches deep, the moment of inertia of which is 145 inch units when the skin stress reaches 7.5 tons per square inch.

14. What total distributed load may be carried by a simply supported beam over a span of 20 feet, the depth of section being 12 inches, the moment of inertia being 375 inch units, and the allowable intensity of stress 7.5 tons per square inch? What load at the centre might be carried with the same maximum stress?

15. To what radius may a beam of symmetrical section 10 inches deep be bent without producing a skin stress greater than 6 tons per square inch, if  $E = 13,500$  tons per square inch? What would be the moment of resistance, if the moment of inertia of the section is 211 inch units?

## CHAPTER V.

### STRESSES IN BEAMS.

**66. Moment of Inertia of a Section Area.**—The intensity of stress produced at any point in the cross-section of a beam depends upon the straining action and the dimensions of the beam. In Art. 63 a relation was found between the bending moment the stress produced, the depth of the beam, and the moment of inertia ( $I$ ) or second moment of the area of cross-section, the quantity  $I$  being defined by the relation—

$$I = \Sigma(y^2 \cdot \delta A)$$

where values of  $y$  are the distances of elements of area  $\delta A$  from the axis about which the quantity  $I$  is to be estimated, viz. the neutral axis of the section.

The calculation of the quantity  $I$  for various simple geometrical figures about various axes will now be briefly considered. The summation denoted by  $\Sigma(y^2 \cdot \delta A)$  can often be easily carried out by ordinary integration. If  $A$  be the area of any plane figure and  $I$  its moment of inertia about an axis in its plane, the radius of gyration ( $k$ ) of the area about that axis is defined by the relation—

$$k^2 A = I = \Sigma(y^2 \cdot \delta A)$$

or  $k$  is that value of  $y$  at which, if the area  $A$  were concentrated, the moment of inertia would be the same as that of the actual figure. Two simple theorems are very useful in calculating moments of inertia of plane figures made up of a combination of a number of parts of simple figures such as rectangles and circles.

*Theorem (1).*—The moment of inertia of any plane area about any axis in its plane exceeds that about a parallel line through its centre of gravity (or centroid) by an amount equal to the product of the area and the square of the distance of the centroid from the axis.

Otherwise, if  $I$  is the moment of inertia of an area  $A$  about any axis in the plane of the figure, and  $I_G$  is the moment of inertia about a parallel axis through the centroid, and  $l$  is the distance between the two axes—

$$I = I_G + l^2 A \quad \dots \dots \dots (1)$$

or, dividing each term by  $A$ —

$$k^2 = k_G^2 + l^2 \quad \dots \dots \dots (2)$$

where  $k$  is the radius of gyration about any axis distant  $l$  from the centroid and  $k_G$  that about a parallel axis through the centroid. The proof of the theorem may be briefly stated as follows:—

$$\begin{aligned} I &= \Sigma\{(l+y)^2\delta A\} = \Sigma\{l^2 + 2ly + y^2\}\delta A \\ &= l^2\Sigma(\delta A) + 2l\Sigma(y \cdot \delta A) + \Sigma(y^2\delta A) \\ &= l^2 \cdot A + 0 + I_G \end{aligned}$$

when  $y$  is measured from an axis through the centroid.

*Theorem (2).*—The sum of the moments of inertia of any plane figure about two perpendicular axes in its plane is equal to the moment of inertia of the figure about an axis perpendicular to its plane passing through the intersection of the other two axes. Or, if  $I_z$ ,  $I_x$ , and  $I_y$  are the moments of inertia about three mutually perpendicular axes OZ, OX, and OY intersecting in O, OX and OY being in the plane of the figure—

$$\text{for } \Sigma(r^2 \cdot \delta A) = I_z = I_x + I_y \quad \Sigma(y^2 \cdot \delta A) + \Sigma(x^2 \delta A) \text{ or } \Sigma\{(x^2 + y^2)\delta A\}$$

where  $r$ ,  $y$ , and  $x$  are the distances of any element of area  $\delta A$  from OZ, OX, and OY respectively, since  $r^2 = x^2 + y^2$ .

*Rectangular Area.*—The moment of inertia of the rectangle ABCD, Fig. 77, about the axis XX may be found as follows, using the notation given in the figure, by taking strip elements of area  $b \cdot dy$  parallel to XX—

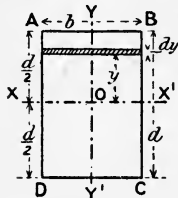

FIG. 77.

$$I_{XX} = \int_{-\frac{d}{2}}^{\frac{d}{2}} y^2 \cdot b \, dy = \frac{1}{3}b \left[ y^3 \right]_{-\frac{d}{2}}^{\frac{d}{2}} = \frac{1}{12}bd^3$$

Similarly about YY—

$$I_{YY} = \frac{1}{12}db^3$$

About DC, by theorem (1) above—

$$I_{DC} = I_{XX} + bd \cdot \left(\frac{d}{2}\right)^2 = bd^3 \left(\frac{1}{12} + \frac{1}{4}\right) = \frac{1}{3}bd^3$$

which might also be obtained by integrating thus—

$$I_{DC} = \int_0^d by^2 \, dy = \frac{1}{3}bd^3$$

$y$  being measured from DC.

*Hollow Rectangular Area and Symmetrical I Section.*—The moment of inertia about the axes XX of the two areas shown in Fig. 78 are equal, for the difference of distribution of the areas in a direction parallel to XX does not alter the moment of inertia about that line. In either case—

$$I_{XX} = \frac{1}{12}(BD^3 - bd^3)$$

*Triangular Area.*—For any of the triangles shown in Fig. 79 about the base  $b$ —

$$I_{xx} = \int_0^h b \times \frac{h-y}{h} y^2 dy = \frac{b}{h} \int_0^h (hy^2 - y^3) dy = \frac{1}{12} bh^3$$

and using theorem (1), about a parallel axis GG through the centroid—

$$I_{GG} = I_{xx} - \frac{1}{2}bh\left(\frac{1}{3}h\right)^2 = \frac{1}{36}bh^3$$

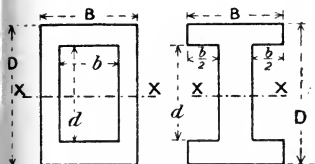

FIG. 78.

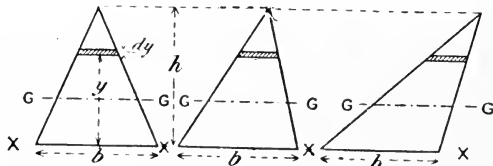

FIG. 79.

*Circular Area.*—The moment of inertia  $I_0$  about an axis perpendicular to the circular surface and through its centre (Fig. 80) is found by taking circular strips of radius  $r$  and width  $dr$ .

$$I_0 = \int_0^R r^2 \cdot 2\pi r dr = 2\pi \frac{R^4}{4} = \frac{1}{2}\pi R^4 \text{ or } \frac{\pi}{32} D^4$$

Using theorem (2)—

$$I_0 = I_{xx} + I_{yy}$$

where  $I_{xx}$  and  $I_{yy}$  are the moments of inertia about two perpendicular diameters XX and YY; and since by symmetry  $I_{xx} = I_{yy}$ —

$$I_0 = 2I_{xx} = 2I_{yy}$$

and

$$I_{xx} = I_{yy} = \frac{1}{4}\pi R^4 \text{ or } \frac{\pi}{64} D^4$$

which might easily be established by taking straight strips parallel to XX or YY.

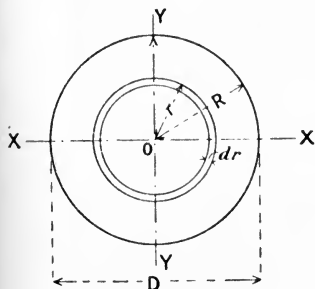

FIG. 80.

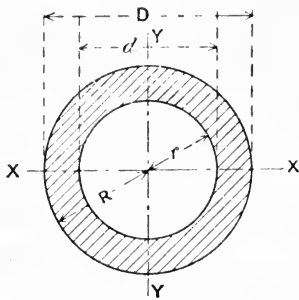

FIG. 81.

*Circular Ring Area.*—Evidently, from the above result, if  $I_0$  is the moment of inertia about a central axis perpendicular to the plane of Fig. 81—

$$I_0 = \frac{\pi}{2}(R^4 - r^4) \text{ or } \frac{\pi}{32}(D^4 - d^4)$$

and  $I_{XX} = I_{YY} = \frac{\pi}{4}(R^4 - r^4)$  or  $\frac{\pi}{64}(D^4 - d^4)$

*Modulus of Section (Z).*—When the foregoing plane figures are the cross-sections of beams, the moment of inertia about the neutral axis is usually one of those given above, and the modulus of section (Art. 63) is equal to this moment of inertia divided by the half depth ( $\frac{D}{2}$ ). The various values are shown in the annexed table.

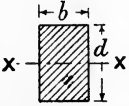
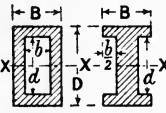
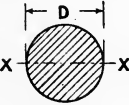
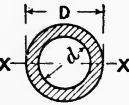
Section	Moment of inertia $I_{XX}$ .	Modulus of section (Z).
	$\frac{1}{12}bd^3$	$\frac{1}{6}bd^2$
	$\frac{1}{12}(BD^3 - bd^3)$	$\frac{1}{6}\left(\frac{BD^3 - bd^3}{D}\right)$
	$\frac{\pi}{64}D^4$	$\frac{\pi}{32}D^3$
	$\frac{\pi}{64}(D^4 - d^4)$	$\frac{\pi}{32}\left(\frac{D^4 - d^4}{D}\right)$

EXAMPLE 1.—A timber beam of rectangular section is to be simply supported at the ends and carry a load of  $1\frac{1}{2}$  ton at the middle of a 16-foot span. If the maximum stress is not to exceed  $\frac{3}{4}$  ton per square inch and the depth is to be twice the breadth, determine suitable dimensions.

The reactions at the ends are each  $\frac{3}{4}$  ton, and the bending moment at the centre is—

$$\frac{3}{4} \times 8 \times 12 = 72 \text{ tons-inches}$$

The modulus of section (Z) is given by—

and if  $\frac{3}{4} \times Z = 72$        $Z = 96(\text{inches})^3$   
 $b = \frac{1}{2}d$   
 $\frac{1}{6}bd^3 = \frac{1}{12}d^3 = 96$   
 $d = \sqrt[3]{1152} = 10.5 \text{ inches nearly}$   
 $b = 5.25 \text{ inches}$

EXAMPLE 2.—Compare the weights of two beams of the same material and of equal strength, one being of circular section and solid and the other being of hollow circular section, the internal diameter being  $\frac{3}{4}$  of the external.

The resistance to bending being proportional to the modulus of section, if  $D$  is the diameter of the hollow beam and  $d$  that of the solid one—

$$\frac{\pi}{32} \left\{ \frac{D^4 - (\frac{3}{4}D)^4}{D} \right\} = \frac{\pi}{32} d^3$$

$$(1 - \frac{81}{256})D^3 = d^3$$

$$\frac{D}{d} = \sqrt[3]{\frac{256}{175}} = 1.135$$

The weights are—

$$\frac{\text{solid}}{\text{hollow}} = \frac{d^2}{D^2 - (\frac{3}{4}D)^2} = \frac{16}{7} \times \left(\frac{d}{D}\right)^2 = \frac{16}{7} \times \frac{1}{(1.135)^2} = 1.77$$

67. Common Steel Sections.—Such geometrical figures as rectangles and circles, although they often represent the cross-section of parts of machines and structures subjected to bending action, do not form the sections for the resistance of flexure with the greatest economy of material, for there is a considerable body of material situated about the neutral surface which carries a very small portion of the stress. The most economical section for a constant straining action will evidently be one in which practically the whole of the material reaches the maximum intensity of stress. For example, to resist economically a bending moment, which produces a longitudinal direct stress the intensity of which at any point of a cross-section is proportional to the distance from the neutral axis, much of the area of cross-section

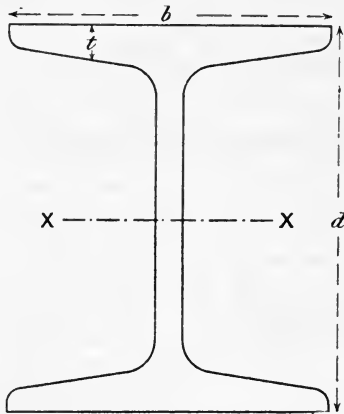

FIG. 82.

should be placed at a maximum distance from the neutral axis. This suggests the I section, which is the commonest form of steel beams whether rolled in a single piece (see Fig. 82) or built up<sup>1</sup> by riveting together component parts. In such a section most of the area is situated at nearly the full half depth, so that, neglecting the thin vertical web, the moment of inertia  $\Sigma(y^2\delta A)$ , approximates to—

$$(\text{area of two flanges}) \times \left(\frac{d}{2}\right)^2$$

<sup>1</sup> Such plate girders are dealt with in the author's "Theory of Structures."

or the radius of gyration approximates to  $\frac{d}{2}$ , and the modulus of section,  $Z$ , which is the moment of inertia divided by  $\frac{d}{2}$ , approximates to—

$$(\text{area of two flanges}) \times \frac{d}{2}$$

or, 
$$Z = 2bt \times \frac{d}{2} = b \cdot t \cdot d \text{ approximately}$$

where  $t$  is the mean thickness of the flange, generally measured in a rolled section at  $\frac{1}{4}$  the breadth from either end. These approximations are often very close to the true values, for they exaggerate by taking the flange area wholly at  $\frac{d}{2}$  from the neutral axis  $XX$  and under-estimate by neglecting the vertical web.

The moment of inertia, etc., of a rolled I section such as that in Fig. 82 may generally be calculated by dividing it into rectangles, triangles, circular sections, and spandrils as shown in Fig. 83, and applying theorem (1) of Art. 66, but such a process is very laborious

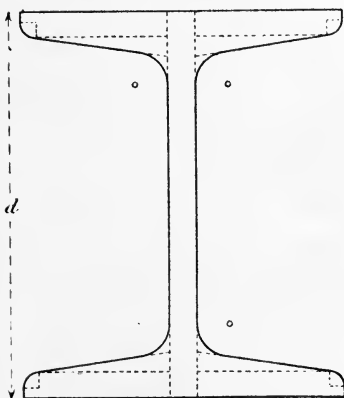

FIG. 83.

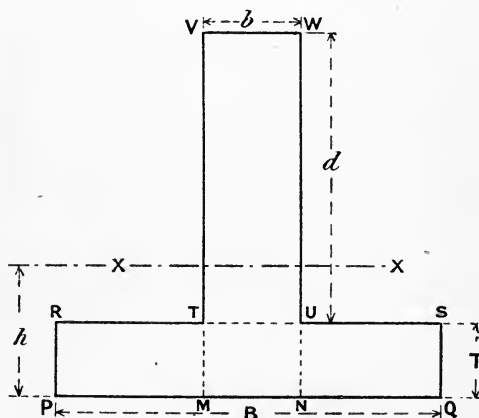

FIG. 84.

and leads to a result of perhaps needless exactness, for all the dimensions, though specified with great precision, could scarcely be adhered to in manufacture with similar exactness. The moments of inertia of the sections recommended by the Engineering Standards Committee have been worked out by the exact method and tabulated. A graphical method suitable for any kind of section is given in the next article.

**T Sections, etc.**—These sections will usually have rounded corners, and if they are known exactly, the moment of inertia may be calculated by division, as in Fig. 83. If, however, the rounding is neglected and the section regarded as consisting of rectangles, as in Fig. 84, we may



proceed as follows. Find the distance  $h$  of the centre of gravity or centroid from the edge PQ by the methods of moments, thus—

$$h\{(B \cdot T) + (b \cdot d)\} = (B \cdot T \cdot \frac{1}{2}T) + (b \cdot d)(T + \frac{1}{2}d)$$

from which  $h$  can be found.

Then find the moment of inertia  $I_{PQ}$  about PQ taking the rectangles PRSQ and VWUT—

$$I_{PQ} = \frac{1}{3}B \cdot T^3 + \frac{1}{12}b \cdot d^3 + b \cdot d(T + \frac{1}{2}d)^2$$

or taking the rectangles VWNM and twice RTMP—

$$I_{PQ} = \frac{1}{3}(B - b)T^3 + \frac{1}{3}b(T + d)^3$$

Having found  $I_{PQ}$ , apply theorem (1), Art. 66, whence—

$$I_{XX} = I_{PQ} - (BT + bd)h^2$$

Another alternative would be to find  $I_{XX}$  directly by subdivision into rectangles and application of theorem (1) Art. 66; as  $h$  will not generally be so simple a number as the main dimensions, this will generally involve multiplications of rather less simple figures than in the above methods.

Yet another plan would be to find the moment of inertia about VW, thus—

$$I_{VW} = \frac{1}{3}B(d + T)^3 - \frac{1}{3}(B - b)d^3$$

and then apply theorem (1), Art. 66 to find  $I_{XX}$ .

Precisely similar principles may be applied to find the moment of inertia of any section divisible into rectangles and not symmetrical about the neutral axis, *e.g.* that in Fig. 94.

**68. Graphical Determination of Moments, Centroids, and Moments of Inertia of Areas.**—To determine the moment and moment of inertia (or second moment) of sections which are not made up of simple geometrical figures, some approximate form of estimation must generally be employed, and a graphical method offers a convenient solution. Of the various graphical methods, probably the following is the simplest, a planimeter being used to measure the areas.

To find the moment and moment of inertia of any plane figure APQB (Fig. 85), about any axis XX, and the moment of inertia about a parallel axis through the centroid. Draw any line SS parallel to XX and distant  $d$  from it; choose any pole O in XX, preferably the point nearest to the figure APQB. Draw a number of lines, such as PQ and AB across the figure parallel to XX. From the extremities P and Q, etc., project lines perpendicular to SS, meeting it in N and M, etc. Join such points as N and M to O by lines meeting PQ in  $P_1$  and  $Q_1$ , AB in  $A_1$  and  $B_1$ , etc. Through the points so derived, draw in the modified or first derived area  $P_1Q_1B_1A_1$ . Repeat the process on this figure, projecting  $P_1Q_1$  at  $N_1M_1$  and obtaining  $P_2Q_2$  and a second modified figure or derived area  $P_2Q_2B_2A_2$ . Then—

(First derived area  $P_1Q_1B_1A_1$ )  $\times d$  = moment of area PQBA about the line XX, or  $\Sigma(y \cdot \delta A)$ ;

and

$$I_{xx} = \text{area } P_2Q_2B_2A_2 \times d^2$$

or second moment of area PQBA about XX.

And about a parallel axis through the centre of gravity—

$$I_G = I_{xx} - \frac{(\text{area } P_1Q_1B_1A_1)^2}{(\text{area } PQBA)} \cdot d^2$$

*Proof.*—Let the areas PQBA,  $P_1Q_1B_1A_1$  and  $P_2Q_2B_2A_2$  be represented by  $A$ ,  $A_1$ , and  $A_2$  respectively, and their width at any distance  $y$  from

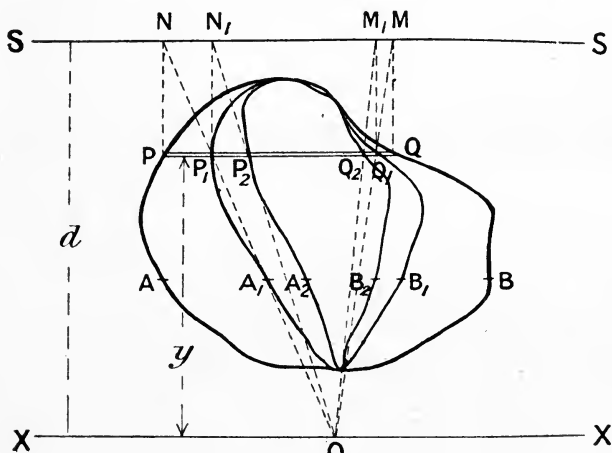

FIG. 85.

XX be denoted by  $z$ ,  $z_1$ , and  $z_2$  respectively. Then elementary strips  $PQ$ ,  $P_1Q_1$ , and  $P_2Q_2$ , or  $\delta A$ ,  $\delta A_1$ , and  $\delta A_2$  of area are respectively equal to  $z \cdot dy$ ,  $z_1 \cdot dy$ , and  $z_2 \cdot dy$ .

In the first derived figure, a strip  $PQ$  is reduced to  $P_1Q_1$  in the ratio  $y$  to  $d$ , or—

$$\delta A_1 = \frac{y}{d} \cdot \delta A \quad \text{or} \quad z_1 dy = \frac{y}{d} \cdot z \cdot dy$$

Taking the sums—

$$A_1, \text{ or } \Sigma(\delta A_1), \text{ or } \Sigma\left(\frac{y}{d} \cdot \delta A\right) = \frac{1}{d} \Sigma(y \cdot \delta A) = \frac{1}{d} \Sigma(y \cdot z \cdot dy)$$

or in integral form—

$$\int z_1 dy = \frac{1}{d} \int y z \cdot dy$$

The area  $A_1$  or  $\Sigma(\delta A_1)$  is therefore proportional to the moment of the area  $A$  about  $XX$ , which is equal to  $A_1 \cdot d$ .

Then the centroid of the area  $A$  is at a distance  $\bar{y}$  from  $XX$  given by—

$$\bar{y} = \frac{\Sigma(y \cdot \delta A)}{\Sigma(\delta A)} = \frac{A_1}{A} \cdot d$$

Again in the second derived figure the strip  $P_1Q_1$  is further reduced to  $P_2Q_2$  in the ratio  $\frac{y}{d}$ , and—

$$\delta A_2 = \frac{y}{d} \cdot \delta A_1 = \frac{y^2}{d^2} \cdot \delta A$$

or 
$$z_2 dy = \frac{y}{d} \cdot z_1 \cdot dy = \frac{y^2}{d^2} \cdot z \cdot dy$$

And taking the sums—

$$A_2, \text{ or } \Sigma(\delta A_2), \text{ or } \Sigma\left(\frac{y}{d} \cdot \delta A_1\right) = \frac{1}{d} \Sigma(y \cdot \delta A_1) = \frac{1}{d^2} \Sigma(y^2 \cdot \delta A)$$

or 
$$\int z_2 dy = \frac{1}{d} \int y \cdot z_1 \cdot dy = \frac{1}{d^2} \int y^2 \cdot z \cdot dy$$

The area  $A_2$  is therefore proportional to the moment of inertia or second moment of the area  $A$  about  $XX$ , which is equal to  $A_2 \times d^2$ , or—

$$I_{XX} = A_2 \cdot d^2$$

And since the distance of the centre of gravity of  $A$  from  $XX$  is  $\frac{A_1}{A} \cdot d$ , by theorem (1) of Art. 66—

$$I_G = A_2 \cdot d^2 - A \bar{y}^2 = A_2 d^2 - A \left(\frac{A_1}{A}\right)^2 d^2 = d^2 \left(A_2 - \frac{A_1^2}{A}\right)$$

A slightly modified construction is shown in Fig. 86, where, instead of using a constant pole as at  $O$  in Fig. 85, a different one is used for

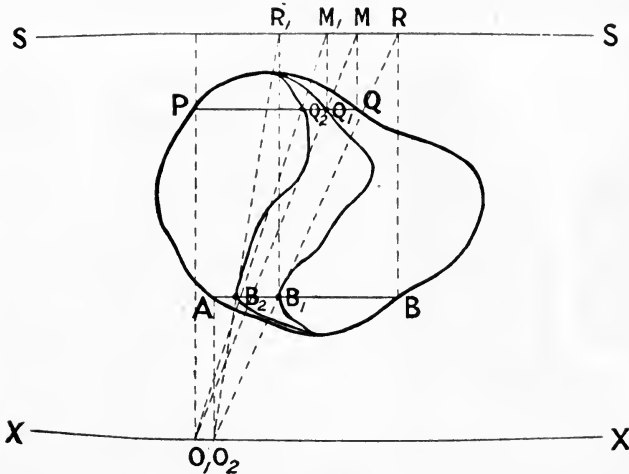

FIG. 86.

each line, such as  $PQ$  or  $AB$ , across the area  $PQBA$ , viz. the foot of the perpendicular from the points such as  $P$  or  $A$  on  $XX$ ; by this means the

left-hand side of the perimeter of the original and derived areas are the same, the areas  $A$ ,  $A_1$ , and  $A_2$  being shown by  $PQBA$ ,  $PQ_1B_1A$ , and  $PQ_2B_2A$  respectively. This construction is rather easier to use in many cases, and with the same care should give rather better results

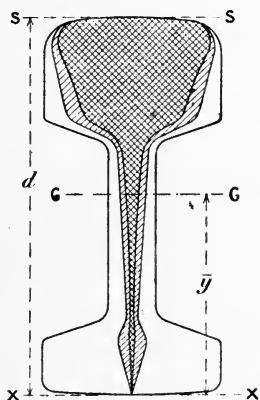

FIG. 87.

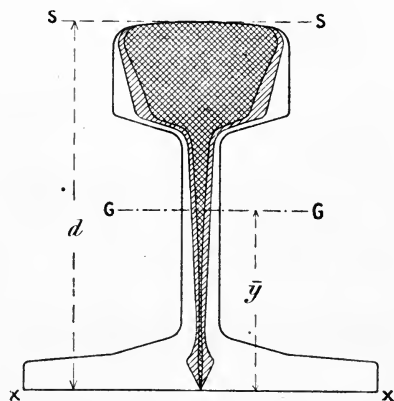

FIG. 88.

than the previous one for areas which are not symmetrical about an axis perpendicular to  $XX$ .

The modulus of section  $Z$  may, in the case of sections symmetrical about the neutral axis, be found by dividing the value of  $I_G$  by the half-depth, and in other cases by dividing the value of  $I_G$  by the distance to the extreme tension or compression layers according to which modulus of section is required (see (8), Art. 63).

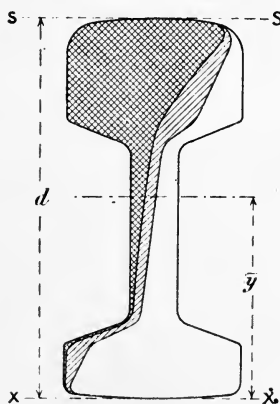

FIG. 89.

Illustrations of these graphical methods are shown in Figs. 87 to 93 inclusive. Figs. 87 and 88 represent rail sections, the centroid and moment of inertia being found as in Fig. 85. Figs. 89 and 90 represent the modified construction of Fig. 86 applied to the same rails as those in Figs. 87 and 88. Figs. 91 and 92 represent symmetrical  $I$  beam sections, the moment of inertia being found as in Fig. 85; but in Fig. 92 the moment of inertia about the usual neutral axis is found directly for half the section without the use of theorem ( $\bar{r}$ ), Art. 66. In this

case twice the inner area multiplied by  $\frac{d}{2}$  gives the modulus of section  $Z$  for the beam. Fig. 93 gives the alternative construction of

Fig. 86 applied to the same section as that in Fig. 92. In Figs. 92 and 93 the first derived area  $A_1$  is evidently such that if the whole were subjected to uniform stress of the intensity which exists at the outer

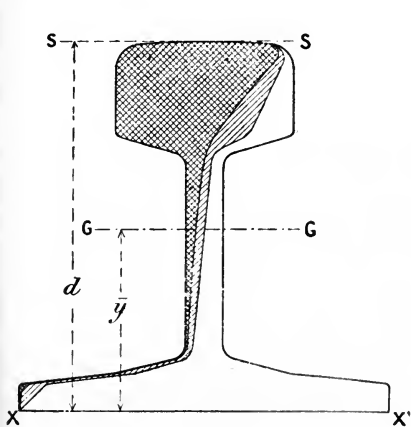

FIG. 90.

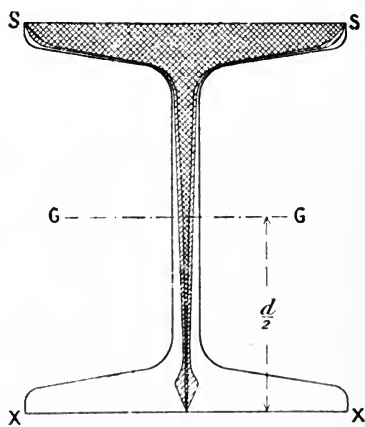

FIG. 91.

skin of the beam, the total stress on the half section would be the same as is actually brought into play in the half section during bending: this is evident since every strip of original area has been reduced in

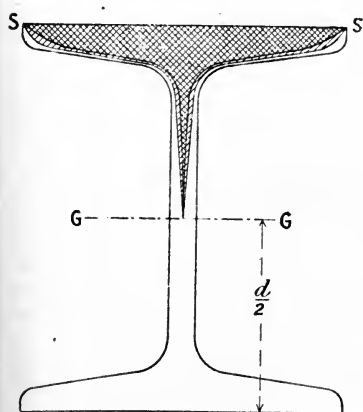

FIG. 92.

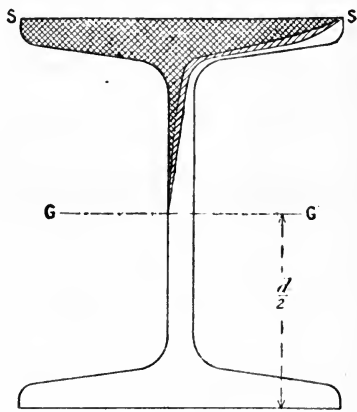

FIG. 93.

the ratio  $\left(y \text{ to } \frac{d}{2}\right)$ , in which the intensity of stress upon it is less than that at the outer skin. The first derived area of a beam section is sometimes called a *modulus figure*.

The "centres" of the parallel longitudinal stresses on either side of the neutral axis will evidently be at the centre of area or centroid (or centre of gravity) of the modulus figure. The longitudinal forces across a transverse section are statically equivalent to the total of the tensile forces acting at the centroid of the modulus figure on the tension side, together with the (equal) total thrust at the centroid of the modulus figure (which is the centre of pressure) on the compression side.

In comparing algebraic and graphical methods, it is useful to remember that the expression  $\frac{1}{y_1} \int yz dy$  represents the area of the modulus figure between the lines corresponding to the limits of integration and parallel to the neutral axis,  $y_1$  or  $\frac{d}{2}$  being the half depth.

**68a. Ellipse of Inertia, or Momental Ellipse.**—*Principal Axes of a Section.*—The principal axes OX and OY of a plane area may be defined as the rectangular axes in its plane, and through the centroid such that the sum  $\Sigma(xy \cdot \delta A)$ , called the *product of inertia* (or product moment), is zero,  $x$  and  $y$  being the rectangular co-ordinates of an element  $\delta A$  of the area with reference to OX and OY.

Let 
$$\begin{aligned} \Sigma(y^2 \cdot \delta A) &= I_x = k_x^2 \cdot \Sigma(\delta A) \\ \Sigma(x^2 \cdot \delta A) &= I_y = k_y^2 \Sigma(\delta A) \end{aligned}$$

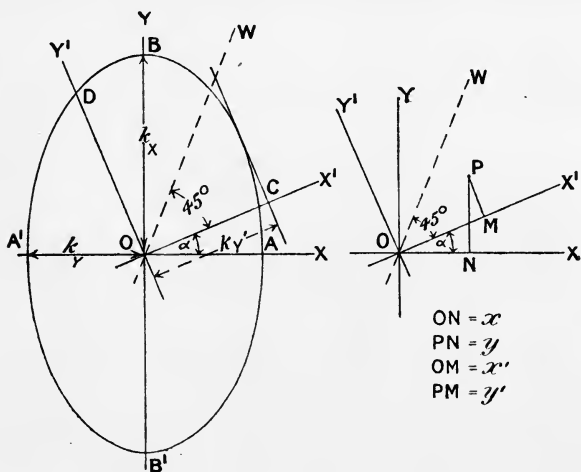

Then the moment of inertia of the area about any perpendicular axes OX' and OY' in its plane when OX' is inclined at an angle  $\alpha$  to OX may be found by writing from the right hand side of Fig. 93A for the co-ordinates  $(x', y')$  of any point P,

$$\begin{aligned} OM &= x' = x \cos \alpha + y \sin \alpha \\ PM &= y' = y \cos \alpha - x \sin \alpha \end{aligned}$$

FIG. 93A.

hence 
$$I_{y'} = \Sigma(x'^2 \cdot \delta A) = \cos^2 \alpha \Sigma(x^2 \delta A) + \sin^2 \alpha \Sigma(y^2 \delta A) + 2 \sin \alpha \cos \alpha \Sigma(xy \delta A)$$

or 
$$k_{y'}^2 = I_{y'} \cos^2 \alpha + I_x \sin^2 \alpha \quad \left. \vphantom{k_{y'}^2} \right\} \text{ since } \Sigma(xy \delta A) = 0 \quad \dots (1)$$

Also similarly—

$$\left. \begin{aligned} I_{x'} &= I_x \cos^2 \alpha + I_y \sin^2 \alpha \\ k_{x'}^2 &= k_x^2 \cos^2 \alpha + k_y^2 \sin^2 \alpha \end{aligned} \right\} \dots \dots \dots (2)$$

Adding (1) and (2)—

$$\left. \begin{aligned} I_{x'} + I_{y'} &= I_x + I_y \\ k_{x'}^2 + k_{y'}^2 &= k_x^2 + k_y^2 \end{aligned} \right\} = \text{constant} \dots \dots \dots (3)$$

A result which follows directly from Theorem (2) Art. 66.

If  $OA = OA'$ , Fig. 93A be set off to represent  $k_y$  and  $OB = OB'$  to represent  $k_x$  and an ellipse  $ABA'B'$  be drawn with  $OA$  and  $OB$  as semi-principal axes, then  $k_{y'}$  is represented by  $OC$ , the perpendicular distance from the centre  $O$  to the tangent parallel to  $OY'$  when  $OX'$  and  $OY'$  are inclined as shown at an angle  $\alpha$  to  $OX$  and  $OY$  respectively. For a property of the ellipse is—

$$OC^2 = OA^2 \cos^2 \alpha + OB^2 \sin^2 \alpha$$

which is the relation given by (1). This *momental ellipse* then shows the radius of gyration about any axis, such as  $OY'$  by the length of the perpendicular from  $O$  on the tangent parallel to  $OY'$ . Also since the product  $OD \cdot OC$  is constant in an ellipse (viz. equal to  $OA \cdot OB$ ), the radius of gyration about any axis such as  $OY'$  is inversely proportional to the radius vector  $OD$  in that direction. Its value is—

$$k_{y'} = \frac{k_x \cdot k_y}{OD}$$

If a curve be drawn such that every radius vector measured from  $O$  is proportional to the square of  $k$ , i.e. proportional to  $I$  about that radius vector, it is called an *inertia curve* for the given section. The radius vector in the direction  $OX'$ , for example, would be given by equation (2), and others might be found similarly.

It is evident by differentiating (1) with respect to  $\alpha$ , or by inspection of the ellipse, that  $k$  has maximum and minimum values,  $k_x$  and  $k_y$ , the values of  $k$  about the two principal axes. It is often important to find the minimum value of  $k$  (and  $I$ ) of a given section, and therefore to find the principal axes. If the section has an axis of symmetry that is evidently one principal axis, for from the symmetry the sum  $\sum(xy \cdot \delta A)$  must be zero. The other principal axis is then at right angles to the first, and through the centroid of the section; a case in point is an angle section with equal sides.

If a plane figure (such as a circular or square section) has more than two axes of symmetry, its momental ellipse becomes a circle, and its moment of inertia about every axis in its plane and through the centroid is the same. If a section has not an axis of symmetry the principal axes and the principal or maximum and minimum moments of inertia may be found from the moments of inertia about two perpendicular axes  $OX'$  and  $OY'$ , say, and the moment of inertia about a third axis  $OW$ , Fig. 93A, inclined  $45^\circ$  to each of the other two; these three moments of inertia may be found by the methods described in the preceding articles. Let  $I_w$  be the moment of inertia about  $OW$ . Then applying (2)—

$$I_w = I_x \cos^2 (\alpha + 45^\circ) + I_y \sin^2 (\alpha + 45^\circ) = \frac{1}{2} I_x (1 - \sin 2\alpha) + \frac{1}{2} I_y (1 + \sin 2\alpha) \dots \dots \dots (4)$$

$$2I_w = I_x + I_y + (I_y - I_x) \sin 2\alpha \dots \dots \dots (5)$$

Hence by (3)  $(I_y - I_x) \sin 2\alpha = 2I_w - (I_{x'} + I_{y'}) \dots \dots \dots (6)$

and subtracting (2) from (1)—

$$(I_y - I_x) \cos 2\alpha = I_{y'} - I_{x'} \dots \dots \dots (7)$$

Dividing (6) by (7)—

$$\tan 2\alpha = \frac{2I_w - (I_x + I_y)}{I_y - I_x} \dots \dots \dots (8)$$

which determines the directions of the principal axes,  $\alpha$  to be measured from  $OX'$  in the direction opposite to  $OW$ .

Also from (3) and (7)—

$$I_x = \frac{1}{2} \{ I_x' + I_y' + (I_x' - I_y') \sec 2\alpha \} \dots \dots (9)$$

$$I_y = \frac{1}{2} \{ I_x' + I_y' - (I_x' - I_y') \sec 2\alpha \} \dots \dots (10)$$

which gives the principal moments of inertia in terms of the three known moments of inertia.

### 69. Some Special Sections. Cast Iron and Concrete Steel.

(1) *Cast Iron Beams.*—Cast iron is generally five or six times as strong in compression as in tension, but a symmetrical section would in bending get approximately equal extreme intensities of tension and compression so long as the material does not greatly deviate from proportionality between stress and strain (see Art. 63). Cast iron has no considerable plastic yield, so that the distribution of stress beyond the elastic limit will not be greatly different from that within it. Hence a cast-iron beam of symmetrical section would fail by tension due to bending, and it would appear reasonable to so proportion the section that the greatest intensity of compressive stress would be about five times that of the tensile stress. This could be done by making the section of such a form that the distance of its centroid from the extreme compression layers is five times that from the extreme tension layers. This, in a flanged or irregular I section, would involve a large tension

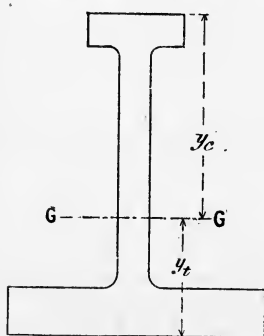

FIG. 94.

flange, and a much smaller compression flange: so great a difference as that indicated above involves serious initial stresses due to the quicker cooling of the small compression flange compared to that of the larger tension flange, and experience shows that distances of the compression and tension edges to the centroid in the ratio of about 2 or 3 to 1 (see Fig. 94) give the most economical results, the tension flange being made wide in order to avoid great thickness, which would involve relatively slow cooling. The moment of inertia of such a section as that shown in Fig. 94 may be estimated by division into rectangles (see Art. 67), or graphically, as in Art. 68.

(2) *Reinforced Concrete Sections.*<sup>1</sup>—Cement and concrete are well adapted to stand high compressive stress, but little or no tension. They can be used to withstand bending by *reinforcement* with metal to take the tension involved, the metal being by various means held fast in the concrete. The usual assumption is that the metal carries

<sup>1</sup> For graphical method see "The Graphic Statics of Reinforced Concrete Sections," in *Engineering*, December 25, 1908.



the whole of the tension, and the concrete the whole of the compression. In the case of a compound beam of this kind, the neutral axis will not generally pass through the centroid of the area of cross-section because of the unequal values of the direct modulus of elasticity ( $E$ ) of the two materials (see Art. 62). It may be found approximately by equating the total compressive force or thrust in the cement to the total pull in the metal. As the cross-section of metal usually occupies a very little of the depth, it is usual to take the area of metal as concentrated at the depth of its centre and subject to a uniform intensity of stress equal to that at its centre.

The following simple theory of flexure of ferro-concrete beams must be looked upon as approximate only, since the tension in the concrete is neglected; and further, in a heterogeneous substance like concrete, the proportionality between stress and strain will not hold accurately with usual working loads. More elaborate and less simple empirical rules have been devised and tested by experiment, but the following methods of calculation are the most widely recognised.

Suppose a ferro-concrete beam has the sectional dimensions shown in Fig. 95; assume that, as in Arts. 61 and 65, the strain due to bending is proportional to the distance from the neutral axis and to the direct modulus of elasticity of the material. Let  $h$  be the depth of the neutral axis from the compression edge of the section,  $f_c$  the (maximum) intensity of compressive stress at that edge, and  $f_t$  the intensity of tensile stress in the metal reinforcement, this being practically uniform. Let  $E_c$  be the direct modulus of elasticity of the concrete in compression, and  $E_t$  that of the steel in tension.

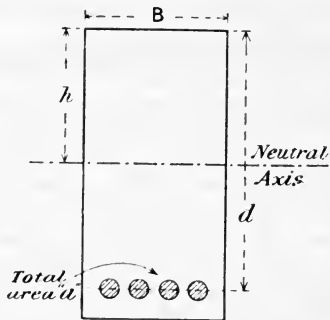

FIG. 95.

Then  $\frac{f_c}{E_c}$  is the proportional strain in the concrete at the compression edge (see Art. 61), and  $\frac{f_t}{E_t}$  is the proportional strain in the metal.

The distances from the neutral axis at which these strains occur are  $h$  and  $(d - h)$  respectively, and since the strains are to be assumed proportional to the distance from the neutral axis (Arts. 61 and 65)—

$$\frac{f_c}{E_c} \div \frac{f_t}{E_t} = \frac{h}{d - h}$$

or,

$$\frac{f_c}{f_t} = \frac{h}{d - h} \cdot \frac{E_c}{E_t} \dots \dots \dots (1)$$

The ratios of  $E_c$  to  $E_t$  for given materials are known; for concrete and steel the ratio is usually from  $\frac{1}{10}$  to  $\frac{1}{15}$ .

The total thrust is—

$$(\text{mean intensity of compressive stress}) \times (\text{compression area}) = \frac{f_c}{2} \cdot h \cdot B$$

The total tensile stress, neglecting any in the concrete, is—

$$f_t \times (\text{area of section of reinforcement}) = f_t \cdot a$$

And since the total thrust equals the total pull, the two together forming the couple which is the moment of resistance—

$$\frac{f_c}{2} \times h \cdot B = f_t \cdot a$$

$$\frac{f_c}{f_t} = \frac{2a}{h \cdot B} \cdot \cdot \cdot \cdot \cdot \cdot \quad (2)$$

and therefore from (1)—

$$\frac{2a}{h \cdot B} = \frac{h}{d - h} \cdot \frac{E_s}{E_c}$$

which gives a quadratic equation in  $h$  in terms of the quantities  $B$ ,  $a$ ,  $d$ , and  $\frac{E_s}{E_c}$ , all of which are supposed to be known.

Ferro-concrete beam sections are generally rectangular, but in case of the compression part of the section having any other shape, we should proceed as follows to state the total thrust in terms of the maximum intensity  $f_c$  at the extreme edge at the (unknown) distance  $h$  from the neutral axis.

Let  $z$  be the width of section parallel to the neutral axis at a height  $y$  from it, varying in a known manner with, say, the distance ( $h - y$ ) from the compression edge, and let  $p$  be the intensity of stress at any height  $y$  from the neutral axis; then—

$$\frac{p}{y} = \frac{f_c}{h} \quad p = \frac{f_c}{h} \cdot y$$

$$\text{Total thrust} = \int_0^h p \cdot z \cdot dy = \frac{f_c}{h} \int_0^h y \cdot z \cdot dy$$

which can be found when the width  $z$  is expressed in terms of, say,  $h - y$ . This might also be written—

$$\text{Total thrust} = f_c \times (\text{area of compression modulus figure})$$

(see end of Art. 68). In the rectangular section of Fig. 95,  $z = B = \text{constant}$ , this being the simplest possible case.

Frequently the compression area of ferro-concrete is **T**-shaped, consisting partly of a concrete slab or flooring and partly of the upper part of the rectangular supporting beam, the lower part of which is reinforced for tension, the floor and beam being in one piece, or "monolithic" (see Ex. 3 below, and note following it). The breadth is then constant over two ranges, into which the above integrations can conveniently be divided. The thrust in the vertical leg of the **T** (or

upper part of the beam) is often negligible compared to that in the cross-piece or slab.

The resisting moment of the total thrust would be—

$$\frac{f_c}{h} \int_0^h y^2 \cdot z dy \quad \text{or} \quad f_c \cdot \frac{I}{h}$$

where  $I$  is the moment of inertia of the compression area about the neutral axis. The graphical equivalent of this would be—

$f_c \times$  (area of compression modulus figure)  $\times$  (distance of its centroid from the neutral axis)

the centroid of the modulus figure being with the centre of pressure or thrust, or, using the second derived area as in Art. 68—

resisting moment of the thrust =  $f_c \times h \times$  second derived area of compression section

The resisting moment of the total tension is evidently  $f_t \times a \times (d - h)$ , and the total moment of resistance is—

total thrust (or pull)  $\times$  distance of centre of thrust from reinforcement

EXAMPLE 1.—A reinforced concrete beam 20 inches deep and 10 inches wide has four bars of steel 1 inch diameter placed with their axes 2 inches from the lower face of the beam. Find the position of the neutral axis and the moment of resistance exerted by the section when the greatest intensity of compressive stress is 100 lbs. per square inch. What is then the intensity of tensile stress in the steel? Take the value of  $E$  for steel 12 times that for concrete.

Using the symbols of Fig. 95 and those above—

$$\begin{aligned} d &= 20 - 2 = 18 \text{ inches} \\ \frac{f_c}{E_c} \div \frac{f_t}{E_t} &= \frac{\text{maximum compressive strain}}{\text{tensile strain in metal}} = \frac{h}{18 - h} \\ \frac{f_c}{f_t} &= \frac{E_c}{E_t} \cdot \frac{h}{18 - h} = \frac{h}{12(18 - h)} \end{aligned}$$

and equating the total pull in the steel to the thrust in the concrete—

$$f_t \cdot 4 \cdot \frac{\pi}{4} = \frac{1}{2} f_c \cdot h \cdot 10$$

$$\text{Therefore} \quad \frac{f_c}{f_t} = \frac{4 \times \frac{\pi}{4}}{h \cdot \frac{1}{2} \cdot 10} = \frac{\pi}{5h} = \frac{h}{(18 - h)12}$$

$$\text{hence} \quad 5h^2 + 12\pi h - 216\pi = 0$$

$$\text{and solving this,} \quad h = 8.5 \text{ inches}$$

The distance from the neutral axis to the centre of the steel rods =  $18 - 8.5 = 9.5$  inches. The total thrust is—

$$\frac{100}{2} \times 10 \times 8.5 = 4250 \text{ lbs.}$$

and the total tension in the metal is equal to this.

The distance of the centre of pressure from the neutral axis is  $\frac{2}{3}$  of 8.5 inches, and that of the tension is 9.5 inches.

The moment of resistance is therefore—

$$(4250)(9.5 + \frac{2}{3} \text{ of } 8.5) = 64,460 \text{ lb.-inches}$$

The intensity of tensile stress in the steel of area  $\pi$  square inches is—

$$f_t = \frac{4250}{\pi} = 1350 \text{ lbs. per square inch}$$

or thus, 
$$\frac{f_t}{100} = 12 \times \frac{9.5}{8.5} = 1342$$

which checks the above approximate result.

**EXAMPLE 2.**—A reinforced concrete floor is to carry a uniformly spread load, the span being 12 feet and the floor 10 inches thick. Determine what reinforcement is necessary and what load per square foot may be carried, the centres of the steel bars being placed  $1\frac{1}{2}$  inch from the lower side of the floor, the allowable stress in the concrete being 600 lbs. per square inch, and in the steel 12,000 lbs. per square inch, and the modulus of direct elasticity for steel being 10 times that for concrete. If the load per square foot of floor is 300 lbs., estimate the extreme stresses in the materials, assuming bending in one direction only.

Let  $h$  = distance of the neutral axis from the compression edge.

Then the distance from the centres of the steel rods is  $10 - 1.5 - h = 8.5 - h$  inches.

The ratio of stress intensities is—

$$\frac{\text{intensity of tensile stress}}{\text{maximum intensity of pressure}} = \frac{12,000}{600} = \frac{8.5 - h}{h} \times 10$$

hence 
$$8.5 - h = 2h$$

$$h = 2.8\bar{3} \text{ inches}$$

Taking a strip of floor 1 inch wide—

$$\text{thrust of concrete} = \frac{600}{2} \times 2.8\bar{3} \times 1 = 850 \text{ lbs.}$$

The total tension in the steel must also be 850 lbs., and the area of section required is therefore—

$$\frac{850}{12,000} = 0.07083 \text{ square inch}$$

per inch width of floor. If round bars 1 inch diameter are used, they might be spaced at a distance—

$$\frac{0.7854}{0.0708} = 11.1 \text{ inches apart}$$

The total moment of resistance is—

$$850\left\{\left(\frac{2}{3} \times 2.8\bar{3}\right) + (8.5 - 2.8\bar{3})\right\} = 6422 \text{ lb.-inches}$$

which is the product of the total thrust (or tension), and the distance between the centre of pressure and the centres of the rods.

If  $w$  = load per inch run, which is also the load per square inch of the floor, equating the moment of resistance to the bending moment—

$$\frac{1}{8}w \times 144 \times 144 = 6422$$

$$144w = \frac{8 \times 6422}{144} = 357 \text{ lbs.}$$

which is the load per square foot.

If the load were only 300 lbs. per square foot, the stresses would be proportionally reduced, and

$$\begin{aligned} \text{maximum intensity of pressure} &= 600 \times \frac{300}{357} \\ &= 505 \text{ lbs. per square inch} \\ \text{intensity of tensile stress} &= 12,000 \times \frac{300}{357} \\ &= 10,090 \text{ lbs. per square inch} \end{aligned}$$

EXAMPLE 3.—A reinforced beam is of T section, the cross-piece or compression flange being 20 inches wide and 4 inches deep, and the vertical leg 14 inches deep by 8 inches wide. The reinforcement consists of two round bars of steel  $1\frac{1}{2}$  inch diameter placed with their axes 2 inches from the lower face. Making the usual assumptions, calculate the intensity of stress in the steel, and the total amount of resistance exerted by a section of the beam when the compressive stress in the concrete reaches 500 lbs. per square inch. Take the modulus of direct elasticity in steel 12 times that for concrete in compression.

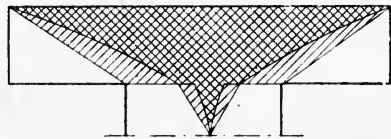
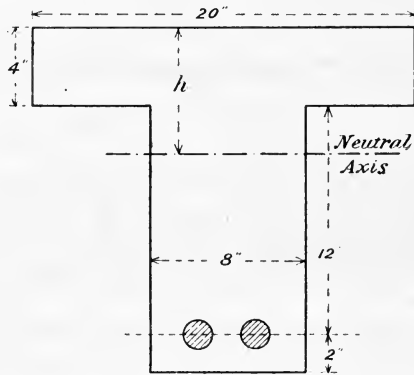

FIG. 96.

Let  $f_t$  = intensity of stress in the steel

$h$  = distance of the neutral axis from the compression edge (see Fig. 96).

The ratio of the stress intensities is then—

$$\frac{f_t}{500} = \frac{16 - h}{h} \times 12$$

whence

$$f_t = \frac{16 - h}{h} \times 6000 \dots \dots \dots (1)$$

$$\begin{aligned} \text{The total thrust} &= \frac{500}{h} \int_{h-4}^h 20y dy + \frac{500}{h} \int_0^{h-4} 8y dy \\ &= \frac{10,000}{h \times 2} \{h^2 - (h-4)^2\} + \frac{4,000}{2h} (h-4)^2 \\ &= \frac{40,000}{h} (h-2) + \frac{2,000}{h} (h-4)^2 \end{aligned}$$

the first term representing the thrust in the cross-piece, and the second that in the vertical leg above the neutral axis. The total tension is—

$$2 \cdot \frac{\pi}{4} \cdot \frac{9}{4} f_t = \frac{9\pi}{8} f_t$$

and substituting for  $f_t$  from (1) and equating to the total thrust—

$$\frac{9\pi}{8} \cdot \frac{16-h}{h} \cdot 6000 = \frac{40,000}{h} (h-2) + \frac{2,000}{h} (h-4)^2$$

from which  $h = 6.6$  inches and—

$$f_t = 6000 \cdot \frac{16-6.6}{6.6} = 8550 \text{ lbs. per square inch.}$$

The moment of resistance for the compression is—

$$\begin{aligned} \frac{500}{6.6} \int_{2.6}^{6.6} 20 \cdot y^2 \cdot dy + \frac{500}{6.6} \int_0^{2.6} 8 \cdot y^2 \cdot dy &= \frac{500 \times 20}{6.6 \times 3} \{(6.6)^3 - (2.6)^3\} \\ &+ \frac{500 \times 8}{6.6 \times 3} (2.6)^3 = 139,000 \text{ lb.-inches} \end{aligned}$$

The moment of resistance for the tension is—

$$8550 \times \frac{9\pi}{8} \times 9.4 = 284,000 \text{ lb.-inches}$$

and the total moment of resistance is—

$$139,000 + 284,000 = 423,000 \text{ lb.-inches}$$

The values found for total thrust and the moment of resistance would not be greatly altered by the omission of the second term in the respective integrals, *i.e.* by neglecting the small thrust in the vertical leg of the section above the neutral axis. The moment of resistance might be estimated graphically by drawing the modulus figure for the compression area with a pole on the neutral axis (see Fig. 96); the moment of resistance for compression would then be—

$$500 \times (\text{area of compression modulus figure}) \times (\text{distance of its centroid from the axis})$$

or if a second derived figure be drawn, the moment would be—

$$500 \times 6.6 \times (\text{area second derived figure})$$

The total tension moment would be—

$$500 \times (\text{area of first compression modulus figure}) \times 9.4$$

*Note.*—A very common example of a **T** section occurs in ferro-concrete floors with monolithic cross-beams, the floor forming the cross-piece of the **T**. The cross-piece is then often very wide in proportion to the remainder of the **T** section, and with a moderately high intensity of stress in the reinforcement the neutral axis would fall within the cross-piece instead of below it. This would involve tension in the lower side of the floor slab, which is not reinforced for tension in that direction, and might start cracks. This undesirable result can be avoided by employing more reinforcement at a consequently lower intensity of stress in the cross-beam or vertical leg of the **T** section.

**70. Beams of Uniform Strength.**—The bending moment generally varies from point to point along a beam in some way dependent on the manner of loading; if the cross-section does not vary throughout the length of the beam, it must be sufficient to carry the maximum bending to which the beam is subjected anywhere, and will therefore be larger than necessary elsewhere. Evidently less material might be used by proportioning the section everywhere to the straining action which it has to bear. This, with practical limitations, is attempted in compound girder sections of various types. In other cases there is seldom any practical advantage in adopting an exactly proportioned variable cross-section, although variable sections are common, e.g. ship masts, carriage springs, and many cantilevers.

A brief indication of the type of variation of section for uniformity of strength will be given. Considering only direct stresses resulting from bending, in order to reach the same maximum stress intensity  $f$  at every cross-section of a beam under a variable bending moment  $M$ , the condition—

$$M = fZ \quad \text{or} \quad Z = \frac{M}{f} \quad \text{or} \quad f = \frac{M}{Z}$$

must be fulfilled, where  $Z$  is the variable modulus of section of the beam. In other words, since  $f$  is to be constant, the modulus  $Z$  must be proportional to the bending moment. Taking rectangular beams in which  $Z = \frac{1}{6}bd^2$  (Art. 66), either  $b$  or  $d$  (or both) may be varied so that  $bd^2$  is proportional to  $M$ . If the beam is a cantilever with an end load  $W$  (see Fig. 59), in which the bending moment at a distance  $x$  from the free end is  $W \cdot x$ , uniform strength for direct stresses may be attained by varying the breadth  $b$  proportionally to  $x$ , i.e. by making the beam of constant depth  $d$  and triangular in plan, thus—

$$\frac{1}{6}bd^2 = \frac{Wx}{f} \quad \text{or} \quad b = \frac{6W}{fd^2} \cdot x$$

In general, for rectangular beams of constant depth the condition of uniform strength would be that the width should vary in the same way as the height of the bending-moment diagram, for—

$$b = \frac{6}{fd^2} \cdot M \quad (f \text{ and } d \text{ being constant})$$

If the breadth is made constant the square of the depth should be

proportional to the bending moment, *i.e.* the depth should be everywhere proportional to the square root of the bending moment, or—

$$d^2 = \frac{6}{f \cdot b} \cdot M \quad (f \text{ and } b \text{ being constant})$$

For solid circular sections in which the diameter varies—

$$Z = \frac{\pi d^3}{32} = \frac{M}{f} \quad \text{or} \quad d^3 = \frac{32M}{\pi f}$$

and the diameter varies as the cube root of the bending moment.

71. **Distribution of Shear Stress in Beams.**—In considering the equilibrium of a portion of a horizontal beam in Art. 56 it was found convenient to resolve the forces across a vertical plane of section into horizontal and vertical components. The variation in intensity of the

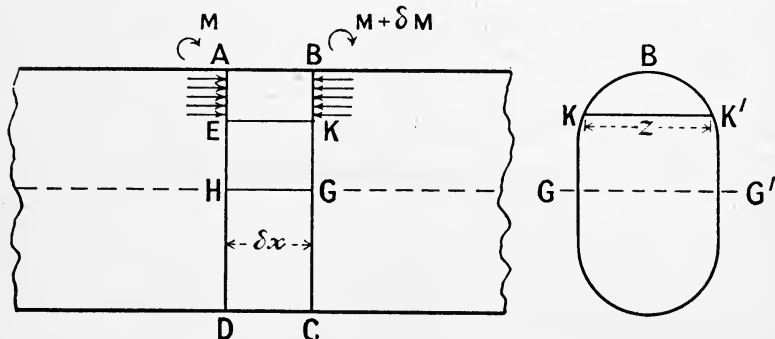

FIG. 97.

horizontal or longitudinal components of stress has been investigated in Arts. 61, 62, and 63, and we now proceed to examine the distribution of the tangential or shearing stress over the vertical cross-section. The vertical shear stress at any point in the cross-section is accompanied by a horizontal shear stress of equal intensity (see Art. 8), the tendency of the former being to produce a vertical relative sliding on either side of the section, and the tendency of the latter being to produce relative horizontal sliding on either side of a horizontal or longitudinal section. The mean intensity of shear stress at a height  $y$  from the neutral axis for a beam may be found approximately as follows:—

In Fig. 97, let AD and BC be two cross-sections of the beam distant EK or  $\delta x$  apart measured along the neutral surface GH; let the variable breadth at any height  $y$  from GH be denoted by  $z$ ; let the bending moment at the section AD be  $M$ , and at BC be  $M + \delta M$ . Then, at any height  $y$  from the neutral surface, the longitudinal or horizontal direct stress intensity on the section AD is—

$$p = \frac{My}{I} \quad (\text{Art. 61})$$



where  $I$  is the moment of inertia of the cross-section. Consider the equilibrium of a portion ABKE between the two sections. On any element of cross-section, of area  $zdy$ , the longitudinal thrust at AE is—

$$p \cdot z \cdot dy \text{ or } \frac{My}{I} \cdot z \cdot dy$$

But at BK, on the element at the same height, the thrust is—

$$\frac{(M + \delta M)y}{I} \cdot z \cdot dy$$

The thrusts on any element at BK being in excess of those at AE by the difference in the above quantities, viz—

$$\frac{\delta M}{I} \cdot y \cdot z \cdot dy$$

the total excess thrust on the area BK over that at AE will be—

$$\int_y^{y_1} \frac{\delta M}{I} \cdot y \cdot z \cdot dy \text{ or } \frac{\delta M}{I} \int_y^{y_1} y \cdot z \cdot dy$$

where  $y_1$  is the extreme value of  $y$ , *i.e.* HA, and  $z$  represents the variable breadth of section between EK and AB. Since the net horizontal force on the portion ABKE is zero, the excess thrust at BK must be balanced by the horizontal shearing force on the surface EK; hence, if  $q$  represents the mean intensity of shear stress at a height  $y$  (neglecting any change in  $q$  in the length  $\delta x$ ), the shearing stress on EK is  $q \cdot z \cdot \delta x$ , and

$$q \cdot z \cdot \delta x = \frac{\delta M}{I} \int_y^{y_1} y \cdot z \cdot dy$$

hence 
$$q = \frac{\delta M}{\delta x} \cdot \frac{I}{I \cdot z} \int_y^{y_1} y \cdot z \cdot dy = \frac{F}{I \cdot z} \int_y^{y_1} y \cdot z \cdot dy \dots (1)$$

where  $F = \frac{dM}{dx}$  (Art. 59 (2)) = total shearing force on the cross-section of the beam. Actually the intensity of shear stress at a height  $y$  varies somewhat, laterally being greatest at the inside.

In the expression  $\frac{F}{I \cdot z} \int_y^{y_1} y \cdot z \cdot dy$ , the symbol  $z$  outside the sign of integration, and the symbol  $y$ , which is the lower limit of integration, refer to a particular pair of values corresponding to the height above HG for which  $q$  is stated, while in the product  $y \cdot z$  within the sign of integration each letter refers to a variable over the range  $y_1$  to  $y$ , or A to E (Fig. 97). It may be noted that the quantity—

$$\int_y^{y_1} y \cdot z \cdot dy$$

is the moment of the area KBK' about the neutral axis GG', which is equal to the area multiplied by the distance of its centre of gravity

or centroid from GG', or the area of so much of a modulus figure (see Art. 68) as lies above KK', multiplied by the height HA or  $y_1$ , so that—

$$q = \frac{F}{I \times KK'} \times (\text{area KBK}') \times (\text{distance of its centroid from GG'}) \quad (2)$$

or—

$$q = \frac{F \times y_1}{I \times KK'} \times (\text{area of modulus figure between B and KK'}) \quad (3)$$

which give graphical methods of calculating the intensity of shear stress at any part of the cross-section.

It is obvious from the above expressions (1) or (3) that  $q$  is a maximum when the lower range of integration is zero (*i.e.* at the neutral surface), and that it is zero at either edge ( $y = y_1$  or  $y = -y_1$ ). If the graphical method with modulus figures be used, the areas on opposite sides of the neutral axis should be reckoned of opposite signs.

*Rectangular Section* (Fig. 98).—Width  $b$ , depth  $d$ . At any height  $y$  from the neutral axis, since  $z$  is constant and equal to  $b$ —

$$q = \frac{F}{Iz} \int_y^{\frac{d}{2}} y \cdot z \cdot dy = \frac{F}{I} \int_y^{\frac{d}{2}} y \cdot dy = \frac{12F}{bd^3} \left( \frac{1}{2} y^2 \right)_y^{\frac{d}{2}} = \frac{6F}{bd^3} \left\{ \left( \frac{d}{2} \right)^2 - y^2 \right\} \quad (4)$$

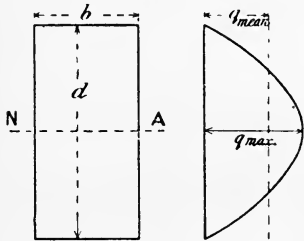

FIG. 98.

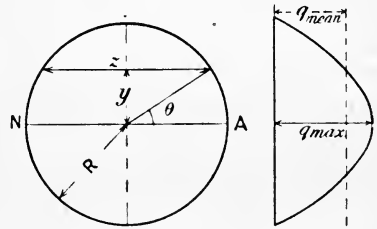

FIG. 99.

If the various values of  $q$  are shown by ordinates on  $d$  as a base-line, as in Fig. 98, the curve is a parabola, and when  $y = 0$ —

$$q = \frac{3}{2} \frac{F}{bd}$$

The mean intensity of shear stress is  $F \div bd$ ; the greatest intensity is thus 50 per cent. greater than the mean.

*Circular Section.*—Writing  $y = R \sin \theta$ , and  $z = 2R \cos \theta$ , and  $dy = R \cos \theta d\theta$ , as in Fig. 99, I being  $\frac{\pi R^4}{4}$ ,

$$\begin{aligned} q &= \frac{4F \times 2R^3}{\pi R^4 \times 2R \cos \theta} \int_0^{\frac{\pi}{2}} \sin \theta \cos^2 \theta d\theta = \frac{4F}{\pi R^2 \cos \theta} \left( \frac{1}{3} \cos^3 \theta \right)_{\frac{\pi}{2}}^0 \\ &= \frac{4F}{3\pi R^2} \cos^2 \theta \quad \text{or} \quad \frac{4F}{3\pi R^2} \left( 1 - \frac{y^2}{R^2} \right) \dots \dots \dots (5) \end{aligned}$$

At the neutral axis,  $\theta = 0$ , or  $y = 0$ , and  $q = \frac{4}{3} \frac{F}{\pi R^2}$  which is  $\frac{4}{3}$  times the mean intensity of shear stress on the section. The other ordinates vary as shown in Fig. 99, the curve being parabolic. These results are only approximate; the stress is considerably greater at the inside, and decreases outwards over the strip  $zdy$ .<sup>1</sup> The mean height of this diagram (Fig. 99) does not represent the mean intensity of shear stress, the width of section not being uniform. In the case of a thin tube thickness of metal  $t$ , the maximum value of  $q$  at the neutral axis would be, taking  $\int_y^{y_1} yzdy$  as the half area multiplied by the distance of its centroid from the neutral axis—

$$q = \frac{2F}{R^2 \cdot 2\pi R t \cdot 2t} \times \pi R t \times \frac{2}{\pi} R = \frac{2F}{2\pi R t}$$

which is twice the mean on the whole section.

*Rectangular I Section with Sharp Corners* (Fig. 100).—In the flange at a height  $y$  from the neutral axis.

$$q = \frac{F}{IB} \int_y^{\frac{D}{2}} y \cdot B \cdot dy = \frac{F}{2I} \left( \frac{D^2}{4} - y^2 \right)$$

and when  $y = \frac{d}{2}$  at the inner edge of the flange—

$$q = \frac{F}{I} \cdot \frac{D^2 - d^2}{8}$$

$$\text{In the web } q = \frac{F}{Ib} \int_y^{\frac{d}{2}} y \cdot z \cdot dy$$

where  $z = B$  over part of the range and  $= b$  over the remainder (the web). The integral may conveniently be split up thus—

$$q = \frac{F}{Ib} \left( B \int_{\frac{d}{2}}^{\frac{D}{2}} y dy + b \int_y^{\frac{d}{2}} y dy \right) = \frac{F}{I} \left( \frac{B}{b} \cdot \frac{D^2 - d^2}{8} + \frac{d^2}{8} - \frac{y^2}{2} \right)$$

When  $y = \frac{d}{2}$ , just inside the web—

$$q = \frac{F}{I} \cdot \frac{D^2 - d^2}{8} \times \frac{B}{b} \quad \text{or} \quad \frac{B}{b} \text{ times that just inside the flange.}$$

And when  $y = 0$ —

$$q = \frac{F}{I} \left\{ \left( \frac{B}{b} \cdot \frac{D^2 - d^2}{8} \right) + \frac{d^2}{8} \right\}$$

<sup>1</sup> A very simple and suggestive idea of the errors involved may be found in a paper on "Faults in the Theory of Flexure," by Mr. H. S. Prichard, in *Trans. Am. Soc. Civil Engineers*, vol. lxxv. pp. 907-908. This paper also gives a good idea of the distortion of initially plane cross sections and simple approximate estimates of the corresponding deviation of stresses from those obtained by the theory of *simple bending*.

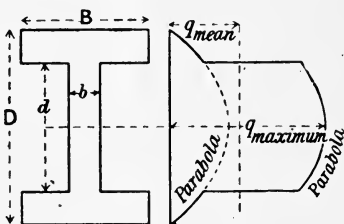

FIG. 100.

The curves in Fig. 100 show the variation in intensity at different heights, both parts being parabolic.

The mean shear stress intensity anywhere might conveniently be stated from (2) above; thus, in the web at level  $y$ —

$$q = \frac{F}{Ib} \times (\text{moment of section area above level } y \text{ about neutral axis})$$

e.g. the maximum stress when  $y = 0$  is (taking moments of parts)—

$$q = \frac{F}{Ib} \left\{ B \left( \frac{D}{2} - \frac{d}{2} \right) \left( \frac{D}{2} + \frac{d}{2} \right)^2 + b \cdot \frac{d}{2} \cdot \frac{d}{4} \right\}$$

which agrees with the previous result.

*Rolled I Section.*—This may best be treated graphically by the method of the modulus figure given above. An example is shown

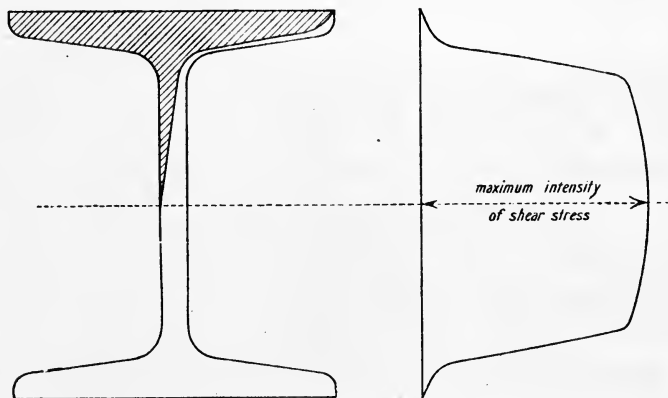

FIG. 101.

in Fig. 101. Every ordinate is proportional to the area of modulus figure above it, divided by the corresponding breadth of the cross-section.

*Built-up Girder Section.*—Fig. 102 shows the intensity of shear stress at different parts of the section of a built-up girder. The stress intensities have been calculated, as in Fig. 100, for the I section, but the integration requires splitting into three parts, as there are three different widths of section.

*Approximation.*—The usual approximation in calculating the intensity of shear stress in the web is to assume that the web carries the whole vertical shearing force with uniform distribution. Fig. 102 shows that the intensity in the web does not change greatly. The intensity of shear stress according to the above approximation is shown by the dotted line WW, which represents the quotient when the whole shearing force on the section is divided by the area of the section of the web. Judging by Fig. 102, this simple approximation to the mean shear stress in the web for such a section is a good one. The line MM shows the

mean intensity of shearing stress, *i.e.* the whole shearing force divided by the whole area of section; this is evidently no guide to the intensity of shear stress in the web, which everywhere greatly exceeds it.

EXAMPLE.—A beam of I section 20 inches deep and  $7\frac{1}{2}$  inches wide has flanges 1 inch thick and web 0.6 inch thick, and carries a shearing force of 40 tons. Find what proportion of the total shearing force is

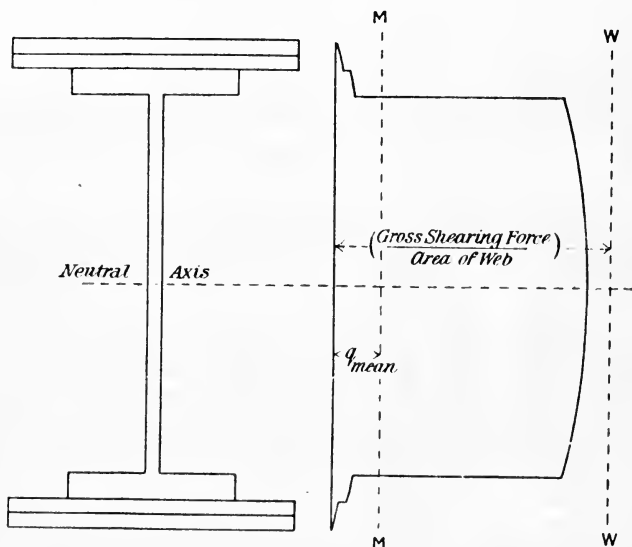

FIG. 102.

carried by the web and the maximum intensity of stress in it, given  $I = 1647$  inch units.

At any height  $y$  from the neutral axis of the section the mean intensity of shearing stress in the web section is—

$$\begin{aligned} q &= \frac{40}{1647 \times 0.6} \left( 7.5 \int_0^{10} y dy + 0.6 \int_0^8 y dy \right) \\ &= \frac{40}{1647 \times 0.6 \times 2} \{ (7.5 \times 19) + 0.6(81 - y^2) \} \\ &= 3.87 - 0.01213y^2 \end{aligned}$$

The stress on a strip of web of depth  $dy$  situated at a height  $y$  from the neutral axis is—

$$q \times 0.6 \times dy$$

and the whole shearing force carried by the web section is—

$$\begin{aligned} 0.6 \int_{-9}^9 q dy &= 0.6 \int_{-9}^9 (3.87 - 0.01213y^2) dy \\ &= 1.2(34.83 - 0.00404 \times 729) = 38.26 \text{ tons} \end{aligned}$$

or 95.6 per cent. of the whole.

The maximum value of  $q$  (when  $y = 0$ ) is evidently 3.87 tons per square inch.

Testing the usual approximation of taking all the shearing stress as spread uniformly over the web section—

$$\frac{40}{0.6 \times 18} = 3.70 \text{ tons per square inch}$$

which is intermediate between the mean value of  $q$  in the web, viz.—

$$\frac{38.26}{0.6 \times 18} \text{ or } 3.54 \text{ tons per square inch}$$

and the maximum intensity 3.87 tons per square inch.

**72. Pitch of Rivets in Girder.**—In compound I sections the flanges and web being plates, the connection between the two parts is made by angle irons riveted to the web and to the flanges (see Fig. 103). The

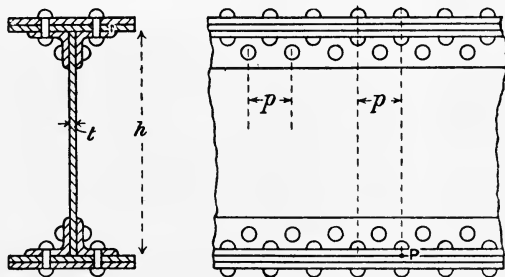

FIG. 103.

rivets have then to transmit the longitudinal shear between the web and the flanges. Let  $p$  be the pitch of the rivets and let  $R$  be the safe working resistance of one rivet to fracture. Neglecting any variation in intensity of the shear stress in the web and adopting the approximation mentioned in the previous article, the intensity of shear stress, horizontally and vertically, is—

$$q = \frac{F}{t \cdot h}$$

where  $t$  = thickness, and  $h$  = depth of web, and  $F$  = gross shearing force on the section. In a distance  $p$  horizontally the total horizontal shearing force to be resisted is  $q \cdot p \cdot t$ , hence—

$$qpt = R \\ p = \frac{R}{q \cdot t} = \frac{R \cdot h}{F}$$

which might also be obtained by taking moments about a point  $P$  (Fig. 103) of the forces on a section of the web of length  $p$ , remembering that the only important force on the web is the shearing force  $F$ .

The expression above for the pitch  $p$  shows that in a girder of constant depth  $h$  the pitch may be made greater where the variable shearing force  $F$  is smaller; for example, towards the middle of the span of a girder carrying a distributed load. Often a pitch suitable for the section of a maximum shearing force is used throughout for convenience instead of a variable pitch. The working resistance  $R$  of a single rivet may be found by its resistance to fracture by shearing or by its resistance to crushing across a diameter. In the former case, for the rivets attaching the angles to the web, since two circular sections in each rivet resist shearing—

$$R = 2 \cdot \frac{\pi}{4} \cdot d^2 \cdot f_s$$

where  $d$  is the diameter of the rivet, and  $f_s$  is the safe intensity of shear stress. The resistance to crushing is—

$$d \cdot t \cdot f_b$$

where  $f_b$  = safe intensity of crushing or bearing stress on the projected area of the rivet;  $f_b$  is generally taken as about twice  $f_s$ . The working resistance should be taken as the lower of the above values; this will be the resistance to crushing only when the web is very thin.

For attaching the angles to the flanges twice as many rivets will be necessary if the shearing resistance is the criterion, for each rivet only offers one circular area of resistance to shear; this will require the same pitch  $p$  as before on either side of the web, there being then twice as many rivets as are used for attaching the angles to the web. If, however, resistance to crushing is the criterion throughout, a pitch  $2p$  might be used to attach the angles to the flange.

For vertical joints in the web, two pieces being connected by double cover plates, the rivets are in double shear, and the pitch  $p = \frac{R h}{F}$  may be used, where  $F$  is the value of the shearing force at the vertical section at which the joint occurs, and  $R$  is the smaller of the two rivet resistances given above.

EXAMPLE.—The web of a girder is  $\frac{3}{4}$ -inch steel plate, and is 50 inches high. Find a suitable pitch for 1-inch rivets to attach the web to the flanges, the angle plates being 6 inch  $\times$  6 inch  $\times$   $\frac{1}{2}$  inch, the average shear stress in the rivets to be 4 tons per square inch, and the total shearing force on the section being 150 tons.

The total resistance of a 1-inch rivet in the web, being in double shear, is—

$$2 \times 0.7854 \times 4 = 6.28 \text{ tons}$$

Using the formula above—

$$p = \frac{6.28 \times 50}{150} = 2.09 \text{ incl. (say 2 inches)}$$

This is too small for 1-inch rivets in a single row, but double rows,

arranged as shown in Fig. 104, in each of which the distance between rivets is 4 inches, will give the same resistance.

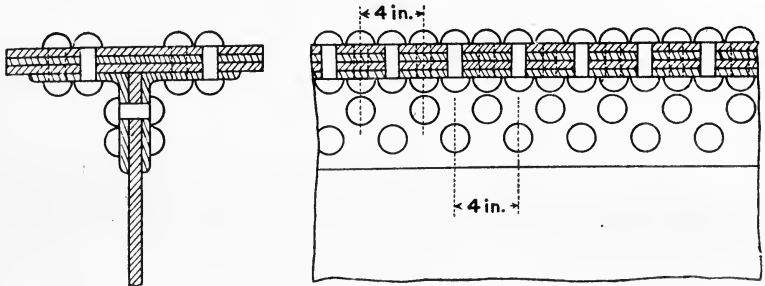

FIG. 104.

**73. Principal Stresses in Beams.**—The intensity of direct stress due to bending, as found in Arts. 61 to 65, and the intensity of horizontal and vertical shear stress, as found in Art. 71, are only, as indicated in Arts. 56, 64, and 65, component stresses in conveniently chosen directions. Within the limitations for which the simple theory of bending is approximately correct (Art. 64), the methods of Arts. 17 and 18 may be applied to find the direction and magnitude of the principal stresses, the greater of which, at any point, has the same sign as the longitudinal direct component there, and makes the smaller (acute) angle with it. Fig. 105 shows the directions of the principal

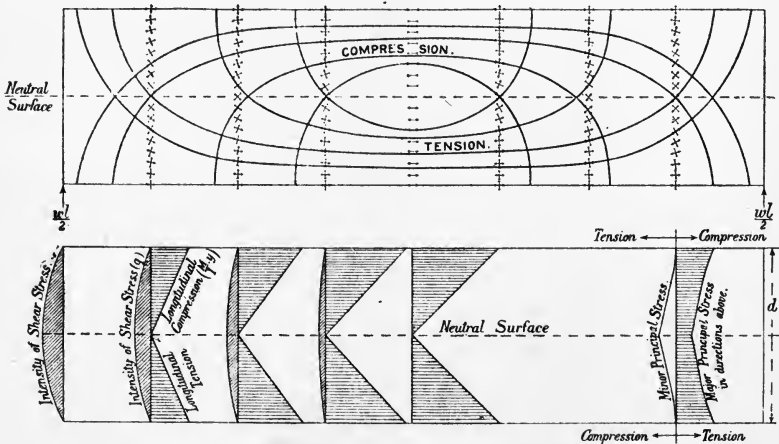

FIG. 105 —Curves of principal stress and magnitudes of principal and component stresses.

stresses at numerous points in a simply supported beam of rectangular cross-section carrying a uniformly distributed load, as well as the



intensities of the component horizontal direct and vertical shear stresses on certain vertical sections, and the intensities of the two opposite principal stresses on one section. The distribution of horizontal direct component stress over a given section is as shown in Fig. 75, and the values of its intensity for a given height vary along the length of the beam, as shown in the bending-moment diagram, Fig. 65. The distribution of tangential or shear stress across vertical sections is as in Fig. 98, and the intensities at a given height vary along the length of the beam, as in the shearing-force diagram in Fig. 65. For the purpose of illustration, the intensity of vertical shearing stress has been made excessive for a rectangular section by taking a span,  $l$ , only four times the depth of the beam. The maximum intensity of vertical (and horizontal) shear stress, which occurs at the middle of the end section, is, by Fig. 65 and Art. 71—

$$q = \frac{3}{2} \cdot \frac{\frac{1}{2}wl}{bd} = \frac{3}{4} \frac{wl}{bd}$$

where  $w$  is the load per inch run on the span  $l$ .

The maximum intensity of horizontal direct stress, which occurs at the top and bottom of the middle section, is, by Fig. 65 and Art. 63 (7)—

$$f = \frac{1}{8}wl^2 \div \frac{1}{6}bd^2 = \frac{3}{4} \frac{wl^2}{bd^2}$$

hence  $\frac{\text{maximum } q}{\text{maximum } f} = \frac{d}{l} = \frac{1}{4}$

The *magnitudes* of the principal stresses for all points in the one cross-section  $\frac{1}{8}l$  from the right-hand support have been calculated from the formula (3) in Art. 18, and are shown in Fig. 105. The two principal stresses are of opposite sign, and the larger one has the same sign as the direct horizontal stress, *i.e.* it is compressive above the neutral axis and tensile below it. The diagram does not represent the direction of the principal stresses at every point in this section.

For such a large ratio of depth to span as  $\frac{1}{4}$ , the simple theory of bending could not be expected to give very exact results, but with larger spans the shearing stresses would evidently become more insignificant for a rectangular section. The magnitudes shown in Fig. 105 must be looked upon as giving an idea of the variation in intensity rather than an exact measure of it.

*Curves of Principal Stress.*—Lines of principal stress are shown in Fig. 105 on a longitudinal section of the beam. They are such that the tangent and normal at any point give the direction of the two principal stresses at that point. There are two systems of curves which cut one another at right angles: both cross the centre line at  $45^\circ$  (see Arts. 8 and 15). The intensity of stress along each curve is greatest when it is parallel to the length of the beam and diminishes along the curve to zero, where it cuts a face of the beam at right angles. For larger and more usual ratios of length to depth, for rectangular beams the curves would be much flatter, the vertical shearing stress being smaller in proportion about mid-span.

*Maximum Shearing Stress.*—At any point in the beam the intensity of shear stress is a maximum on two planes at right angles, inclined at  $45^\circ$  to the principal planes, and of the amount shown in Art. 18 (4), viz. half the algebraic difference of the principal stress intensities, which is, in the case shown in Fig. 105, half the arithmetic sum of the magnitudes of the principal stress intensities taken with like sign.

*Principal Stresses in I Sections.*—In I sections, whether rolled in one piece or built up of plates and angles, it has been shown (Art. 67) that the web area is of little importance in resisting the longitudinal direct stresses due to bending, or, in other words, it contributes little to the modulus of section; and in Art. 71 (Fig. 102) it was shown that the flanges carry little of the shear stress. It should be noticed, however, that in the web near the flange the *intensity* of longitudinal direct stress is not far below the maximum on the section at the outer layers, while the intensity of vertical shear stress is not much lower than the maximum, which occurs at the neutral plane. The principal stress in such a position may consequently be of higher intensity than either of the maximum component stresses (see example below). Only low shear-stress intensities are allowed in cross-sections of the webs of I-section girders; it should be remembered that the shear stresses involve tensile and compressive principal stresses, which may place the thin web in somewhat the condition of a long strut. See also remarks in Art. 25 on the strength of material acted on by principal stresses of opposite kinds, which is always the case in the webs of I sections, where, in the notation of Art. 18—

$$p = \frac{p_1}{2} \pm \sqrt{\left(\frac{p_1}{2}\right)^2 + q^2}$$

For full consideration of the design of plate girder webs, the reader should consult a treatise on "Structures."

**EXAMPLE.**—A beam of I section, 20 inches deep and  $7\frac{1}{2}$  inches wide, has flanges 1 inch thick, and web 0.6 inch thick. It is exposed at a particular section to a shearing force of 40 tons, and a bending moment of 800 ton-inches. Find the principal stresses (*a*) at the outside edges, (*b*) at the middle of the cross-section, (*c*)  $1\frac{1}{2}$  inch from the outer edges.

The moment of inertia about the neutral axis is—

$$\frac{1}{12}(7.5 \times 20^3 - 6.9 \times 18^3) = 1647 \text{ (inches)}^4$$

(*a*) At the outside edges  $f = \frac{800 \times 10}{1647} = 4.86$  tons per square inch pure tension or compression, the other principal stress being zero.

(*b*) At the middle of the cross-section the intensity of vertical and horizontal shear stress is—

$$q = \frac{40}{1647 \times 0.6} \left( 7.5 \int_9^{10} y dy + 0.6 \int_0^9 y dy \right) = 3.87 \text{ tons per square inch}$$

as in example at end of Art. 71.

This being a pure shear, the equal principal stresses of tension and

compression are each inclined  $45^\circ$  to the section, and are of intensity 3.87 tons per square inch.

(c) Intensity of direct stress perpendicular to the section is—

$$p_1 = \frac{800 \times 8.5}{1647} = 4.13 \text{ tons per square inch}$$

The intensity of vertical shear stress on the section is—

$$q = \frac{40}{1647 \times 0.6} \left( 7.5 \int_9^{10} y dy + 0.6 \int_{8.5}^9 y dy \right)$$

$$= \frac{40}{1647 \times 2 \times 0.6} \{ (7.5 \times 19) + 0.6(81 - 72.25) \}$$

$$q = 2.99 \text{ tons per square inch}$$

Hence, the principal stresses are, by Art. 18—

$$p = \frac{p_1}{2} \pm \sqrt{\left\{ \left( \frac{p_1}{2} \right)^2 + q^2 \right\}} = 2.065 \pm 3.63$$

which are 5.695 and  $-1.565$  tons per square inch, and the major principal stress is inclined at an angle—

$$\tan^{-1} \frac{2.99}{5.695} \quad \text{or} \quad 27^\circ 40' \quad (\text{see Art. 18 (2)})$$

to the corresponding direct stress along the flange, or  $62^\circ 20'$  to the cross-section.

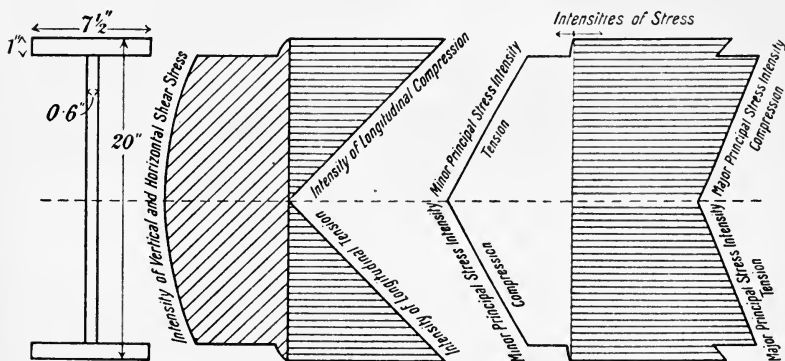

FIG. 106.—Magnitudes of component and principal stress intensities in I-section beam.

This illustrates the fact that just within the flange of an I section, carrying a considerable bending moment and shearing force, the intensity of the principal stress (5.695) may exceed that at the extreme outside layers of the section.

The intensities of principal stress in the web, calculated as above, are shown in Fig. 106, which shows that the material bears principal stresses the greater of which is nowhere greatly less than the maximum.

In accepting such conclusions as to principal stresses, the limitations of the simple theory of bending should be borne in mind: these results can only be looked upon as approximations giving a useful idea of the nature of the stresses.

**74. Bending beyond the Elastic Limit. Modulus of Rupture.**— If bending is continued after the extreme fibres of a beam reach the limit of elasticity, the intensity of longitudinal stress will no longer be proportional to the longitudinal strains, and the distribution of stress will not be as shown in Fig. 75. For moderate degrees of bending beyond the elastic limit, the assumption that plane sections remain plane is often nearly true. In this case the *strains* will be proportional to the distances from the neutral axis (Art. 61), and the longitudinal stress intensities will vary from the neutral axis to the extreme layers, practically as in stress-strain diagrams for direct stress. Different

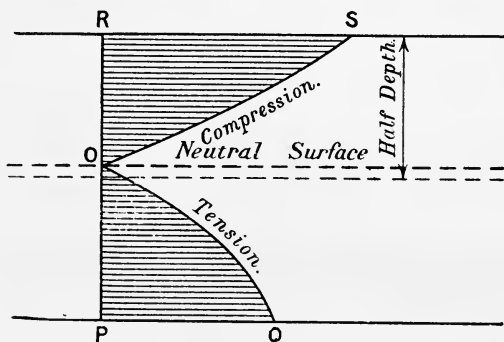

FIG. 107.

types of distribution will occur according as the elastic limit is reached first in tension or compression, or simultaneously. The true elastic limit for cast iron is very low in tension or compression, but at, say, 8 tons per square inch the strain in tension is much greater, and deviates much more from proportionality to stress than in compression. The distribution of stress on a symmetrical section will therefore be somewhat as in Fig. 107; the neutral surface will no longer pass through the centroid of the area of cross-section, but will be nearer the compression edge, which, yielding less than the tension edge, will have a greater intensity of stress. If the beam is of constant breadth, *i.e.* of rectangular cross-section, the neutral surface will move from half-depth in such a way that the areas  $OPQ$  and  $ORS$  remain equal, for the total tension and total thrust are of equal magnitude, and form a couple.

If the material of a beam has the same stress-strain diagram in tension and in compression, the neutral surface will continue to pass through the centroid of the area of cross-section, the distribution of tension and compression being symmetrical, but the intensity of stress

will not in either case be proportional to the distance from the neutral surface (see Fig. 108) after the elastic limit is exceeded; the material nearer the neutral surface will carry a *higher* intensity of stress than if

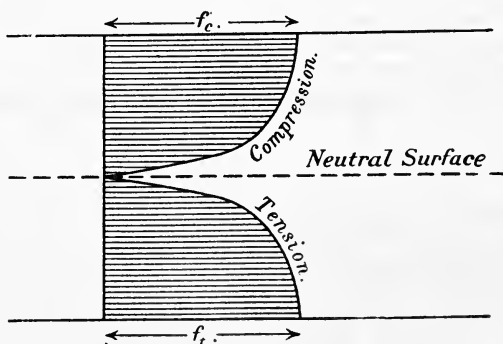

FIG. 108.

the stress were proportional to the distance from the neutral surface, the intensities being intermediate between a proportional and a uniform distribution.<sup>1</sup>

*Modulus of Rupture.*—When a bar of metal is tested by bending until rupture takes place, the intensities of stress at the outer layers at rupture are not those given by the formula (6) in Art. 63, viz.—

$$f_t = M \frac{y_t}{I} \quad \text{and} \quad f_c = M \frac{y_c}{I}$$

since the condition of elasticity there assumed has ceased to hold good. Nevertheless, the quantity—

$$M \frac{y_1}{I} \quad \text{or} \quad \frac{M}{Z}$$

where  $M$  is the bending moment at rupture, is very often used as a guide to the quality of cast iron, the bending test with a central load being easily arranged. It is evidently not a true intensity of stress, and is called the *transverse modulus of rupture*. The term is practically confined to the tests of a rectangular section, and in cast iron the modulus is much higher than the ultimate tenacity in a tensile test, for two reasons. Firstly, because the tensile strain at comparatively low stress at one edge allows a distribution of stress similar to that sketched in Fig. 107, thereby using the high compressive strength of cast iron to advantage. And secondly, because the inner layers of material under the distribution of stress previous to rupture carry a higher intensity of stress than is contemplated by the formula—

$$f_1 \frac{y_1}{I} \quad \text{or} \quad f_1 \div \frac{1}{6} b a^2 \quad (\text{for a rectangular beam})$$

<sup>1</sup> Some experiments on the distribution of strain on cross sections of beams will be found in a paper by Dr. J. Morrow, *Proc. Roy. Soc.*, vol. 73, p. 13.

for the moment of resistance, thereby increasing the resistance. This second reason would not apply in any considerable degree to a thin I section, in which the direct stress is borne almost entirely by the flanges, and with comparatively uniform distribution in them, both before and after the elastic limit is passed (see Fig. 108), near outside edges. Practically, however, the term "modulus of rupture" and the transverse test to rupture are confined to cast iron and timber and to the rectangular section.

**74a. Unsymmetrical Bending.**—In considering simple bending (Art. 61) it was assumed that the beam had a cross section symmetrical about the axis through its centroid and in the plane of bending. The

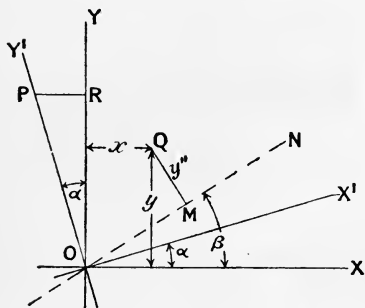

FIG. 108A.

planes of bending and that of the external bending couple will be parallel if the axis of cross section in the plane of the external moment is a principal axis (Art. 68a). If this condition is not fulfilled, let OY', Fig. 108A, be the plane of the external bending moment (shown by its trace on the section which is in the plane of the figure) inclined at an angle  $\alpha$  to the principal axis OY, or let the bending couple M be in a plane perpendicular to OX'. If the couple M, represented by OP, say, be resolved into

components represented by OR and RP about the principal axes OX and OY, these components will be—

$$M \cos \alpha \text{ and } -M \sin \alpha \text{ respectively.}$$

The intensity of bending stress and the strain everywhere on the section can then be found by taking the algebraic sum of the effects produced by the component bending moments about the two principal axes. Thus, the unit stress at any point Q the co-ordinates of which referred to the principal axes OX and OY are  $x, y$  will be from (5), Art. 63—

$$p = \frac{yM \cos \alpha}{I_x} - \frac{xM \sin \alpha}{I_y} \dots \dots \dots (1)$$

where  $I_x$  and  $I_y$  are the principal moments of inertia of the beam section about OX and OY respectively. For a point the co-ordinates of which are  $-x, y$

$$p = \frac{yM \cos \alpha}{I_x} + \frac{xM \sin \alpha}{I_y} \dots \dots \dots (2)$$

For points on the neutral axis, putting  $p = 0$  in (1)—

$$y = x \frac{I_x}{I_y} \tan \alpha \dots \dots \dots (3)$$

which is a straight line ON through the centroid of the section inclined to OX at an angle  $\beta$ , so that—

$$y = x \tan \beta \dots \dots \dots (4)$$

and

$$\tan \beta = \frac{I_x}{I_y} \tan \alpha \dots \dots \dots (5)$$

It may be noted that the relation (5), which may be written

$$\tan \beta = \frac{k_x^2}{k_y^2} \tan \alpha \dots \dots \dots (6)$$

is that between the slopes of conjugate axes of the momental ellipse (Art. 68a), the principal semi-axes of which are the radii of gyration  $k_y$  about OY in the direction OX and  $k_x$  about OX in the direction OY. Consequently, if the momental ellipse is drawn the direction of the neutral axis ON (Fig. 108A) may be found by drawing the diameter conjugate to OY', which is easily accomplished by joining O to the point of bisection of a chord parallel to OY'.

To find the maximum stress in a given section resulting from a given bending moment in any given plane we first calculate the direction of the principal axes and values of the principal moments of inertia as described in Art. 68a. Then calculate the direction of the neutral axis from (5) and draw it on the given section and find by inspection the point in the section furthest from the neutral axis and apply equation (1). The intensity of stress might also be stated in terms of  $y''$ , the distance from the neutral axis (Fig. 108A) for

$$QM = y'' = y \cos \beta - x \sin \beta \dots \dots \dots (7)$$

and from (5)—

$$y \frac{\cos \alpha}{I_x} \div x \frac{\sin \alpha}{I_y} = \frac{y \cos \beta}{x \sin \beta} \dots \dots \dots (8)$$

hence

$$\left( \frac{y \cos \alpha}{I_x} - \frac{x \sin \alpha}{I_y} \right) \div y'' = \frac{x \sin \alpha}{I_y} \div x \sin \beta \dots \dots (9)$$

and substituting this in (1) and then for  $\sin \alpha$  from (8)—

$$p = \frac{M \cdot y''}{I_y} \cdot \frac{\sin \alpha}{\sin \beta} = \frac{M \cdot y''}{\sqrt{I_x^2 \cos^2 \beta + I_y^2 \sin^2 \beta}} \dots \dots (10)$$

The maximum value  $f_1$ , tensile or compressive of  $p$ , can be found by writing the maximum value of  $y''$  on the tensile or compressive side of the neutral axis.

*Another form of the result.*—The value of  $p$  might also be stated directly in terms of the moment of inertia of the section about the neutral axis ON from the general formula (5) Art. 63, for the component bending moment about ON resulting from the bending moment M about OX' is  $M \cos (\beta - \alpha)$ , hence

$$p = \frac{y'' \cdot M \cos (\beta - \alpha)}{I_N} \dots \dots \dots (11)$$

where  $I_N$  is the moment of inertia about the neutral axes ON, which may be found graphically, as described in Art. 68a, from the momental ellipse or from (2) Art. 68a, writing  $\beta$  for  $\alpha$ , which gives from (11) above—

$$p = \frac{y'' M \cos (\beta - \alpha)}{I_x \cos^2 \beta + I_y \sin^2 \beta} \dots \dots \dots (12)$$

a formula easily reduced to the form (10) by the relation (5) between  $\beta$  and  $\alpha$ .

The choice of one or other method of dealing with a case of unsymmetrical bending will depend partly on the type of section. Thus in rectangular sections a corner will always be a point of maximum stress, and formula (2) may be applied directly. In other sections it may be more convenient to draw the neutral axis to determine for which point in the section the unit stress is a maximum.

**EXAMPLE I.**—Calculate the allowable bending moment on a British Standard unequal angle  $6'' \times 3\frac{1}{2}'' \times \frac{3}{8}''$ , carrying a load on the short edge with the long edge vertically downwards, if the stress is limited to 6 tons per square inch and the area, principal moments of inertia and position of the centroid of the section are given.

The particulars from the standard tables are given in Fig. 108B, and as follows.  $\tan XOX' = \tan \alpha = 0.344$ , hence  $\alpha = 19^\circ$ ;  $I_x = 13.908$  (inches)<sup>4</sup>;  $I_y = 1.963$  (inches)<sup>4</sup>; area = 3.424 square inches, hence  $k_x = 2.015$  inches,  $k_y = 0.757$  inches.

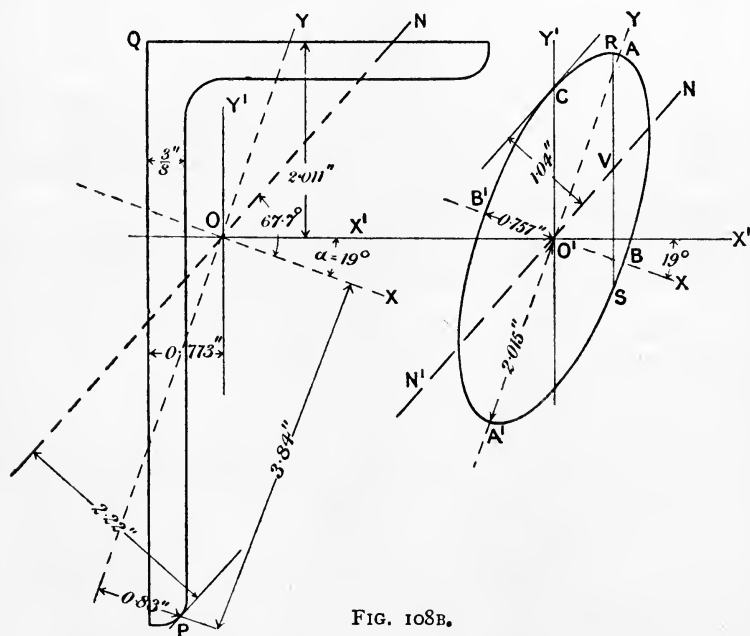

FIG. 108B.

The position of the neutral axis may be found by (5)—

$$\tan \beta = \frac{13.908}{1.963} \times 0.344 = 2.437 = \tan 67.7^\circ$$

The neutral axis  $ON$  is set off on the left of Fig. 108B, and by inspection it is evident that  $P$  is the furthest point in the section from



ON; its distance from OX is  $3.84'' = -y$ , and its distance from OY is  $0.83'' = +x$ , hence from (1) putting  $p = 6$  tons per square inch—

$$6 = -\frac{3.84M \cos 19^\circ}{13.908} - \frac{0.83M \sin 19^\circ}{1.963} = -M(0.261 + 0.1375)$$

hence  $M = -15.05$  ton-inches, the negative sign merely indicating the kind of bending moment, P being, say, on the tension side of the neutral axis ON. The compressive stress at the point Q can readily be found from (1).

*Graphical Solution.*—Set out the momental ellipse on the right of Fig. 108B such that  $\tan \text{XOX}' = 0.344$  or angle  $\text{XOX} = 19^\circ$ ,  $\text{O'A} = k_z = 2.015''$ ,  $\text{O'B} = 0.757''$  (on any scale). Draw any chord RS parallel to OY', and bisect it in V; draw NO'N' the neutral axis through O' and V. Set out this neutral axis ON on the section, as shown to the left of the figure, and look out the distance from it of the most remote point P which measures  $2.22''$ . Through C draw the tangent to the ellipse parallel to ON, and measure its perpendicular distance from NO'N' which is  $1.04''$ . Then the moment of inertia of the section about ON is—

$$(1.04)^2 \times 3.424 = 3.70 \text{ (inches)}^4$$

Then measuring the angle NOX' as  $48.7^\circ$  and applying (11)

$$6 = 2.22 \times M \times \cos 48.7^\circ = 0.396M$$

and  $M = 15.15$  ton-inches, confirming approximately the previous result.

**EXAMPLE 2.**—A British Standard equal angle section measures  $4\frac{1}{2}'' \times 4\frac{1}{2}'' \times \frac{3}{8}''$  and is rounded to a radius of  $0.275$  inch at its outer ends or toes. Its area of section is  $3.236$  square inches, and the distance of its centroid from either outside edge is  $1.244$  inch. Its principal moments of inertia are  $9.768$  (inches)<sup>4</sup> and  $2.514$  (inches)<sup>4</sup>, the former being about an axis through the intersection of the outer edges. A beam of this section, and simply supported at its ends, has one side of the angle horizontal and carries on it a vertical load of  $\frac{1}{2}$  ton midway between the supports, which are 5 feet 4 inches apart. Find the greatest tensile and compressive stresses in the material.

In this case from the symmetry  $\alpha = 45^\circ$ .

If  $\beta$  is the angle which the neutral axis makes with the principal axis passing through the intersection of the edges, from (5)—

$$\tan \beta = \frac{9.768}{2.514} = 3.885$$

Hence from tables  $\beta = 75.6^\circ$

The neutral axis is inclined to the loaded edge at an angle

$$75.6^\circ - 45^\circ = 30.6^\circ$$

The most distant point in tension may be measured from a drawing to scale or calculated; it occurs on the curved toe, as in Fig. 108B. The co-ordinates of the centre of the curve referred to axes parallel to

the angle edges are known, and hence the distance from the neutral axis is easily calculated about an oblique neutral axis; the distance to the curved toe exceeds the distance to the centre by the radius  $0.275''$ . Either method gives  $y'' = 2.26''$ .

About the neutral axis—

$$I_N = 9.768 \cos^2 75.6^\circ + 2.514 \sin^2 75.6^\circ = 2.96 \text{ (inches)}^4$$

which may be checked by drawing the momental ellipse. The bending moment  $M$  midway between the supports is—

$$\frac{1}{4} \times \frac{1}{2} \times 64 = 8 \text{ ton-inches}$$

Hence from (11)—

$$\text{Maximum tensile stress} = \frac{2.26 \times 8 \times \cos 30.6^\circ}{2.96} = 5.26 \text{ tons per sq. inch}$$

Also from the neutral axis to the intersection of the outer edges where the compressive stress is greatest measures  $1.70''$  (viz.  $1.244 \times \sqrt{2} \times \sin 75.6^\circ$ ). Hence, similarly, the maximum compressive stress is—

$$\frac{1.70 \times 8 \times \sin 75.6^\circ}{2.96} = 3.97 \text{ tons per sq. inch.}$$

#### EXAMPLES V.

1. A wooden beam of rectangular section 12 inches deep and 8 inches wide has a span of 14 feet, and carries a load of 3 tons at the middle of the span. Find the greatest stress in the material and the radius of curvature at mid span.  $E = 800$  tons per square inch.

2. What should be the width of a joist 9 inches deep if it has to carry a uniformly spread load of 250 lbs. per foot run over a span of 12 feet, with a stress not exceeding 1200 lbs. per square inch?

3. A floor has to carry a load of 3 cwt. per square foot. The joists are 12 inches deep by  $4\frac{1}{2}$  inches wide, and have a span of 14 feet. How far apart may the centre lines be placed if the bending stress is not to exceed 1000 lbs. per square inch?

4. Compare the moments of resistance for a given maximum intensity of bending stress of beam of square section placed (a) with two sides vertical, (b) with a diagonal vertical, the bending being in each case parallel to a vertical plane.

5. Over what length of span may a rectangular beam 9 inches deep and 4 inches wide support a load of 250 lbs. per foot run without the intensity of bending stress exceeding 1000 lbs. per square inch?

6. A beam of I section 12 inches deep has flanges 6 inches wide and 1 inch thick, and web  $\frac{7}{8}$  inch thick. Compare its flexural strength with that of a beam of rectangular section of the same weight, the depth being twice the breadth.

7. A rolled steel joist 10 inches deep has flanges 6 inches wide by  $\frac{3}{4}$  inch thick. Find approximately the stress produced in it by a load of 15 tons uniformly spread over a span of 14 feet.

8. Find the bending moment which may be resisted by a cast-iron pipe 6 inches external and  $4\frac{1}{2}$  inches internal diameter when the greatest intensity of stress due to bending is 1500 lbs. per square inch.

9. Find in inch units the moment of inertia of a T section, about an axis through the centroid or centre of gravity of the section and parallel to the cross-piece. The height over all is 4 inches, and the width of cross-piece 5 inches, the thickness of each piece being  $\frac{1}{2}$  inch.

10. The compression flange of a cast-iron girder is 4 inches wide and  $1\frac{1}{2}$  inch deep; the tension flange 12 inches wide by 2 inches deep, and the web 10 inches by  $1\frac{1}{2}$  inch. Find (1) the distance of the centroid from the tension edge; (2) the moment of inertia about the neutral axis; (3) the load per foot run which may be carried over a 10-foot span by a beam simply supported at its ends without the skin tension exceeding 1 ton per square inch. What is then the maximum intensity of compressive stress?

In Examples Nos. 11 to 16 inclusive the tension in the concrete is to be neglected, and the modulus of direct elasticity of steel in tension taken as 15 times that of concrete in compression. The concrete is to be taken as perfectly elastic within the working stresses.

11. A reinforced concrete beam 10 inches wide and 22 inches deep has four  $1\frac{1}{4}$ -inch bars of round steel placed 2 inches from the lower edge. If simply supported at the ends, what load per foot run would this beam support over a 16-foot span if the compressive stress in the beam reaches 600 lbs. per square inch? What would be the intensity of tensile stress in the reinforcement?

12. A reinforced concrete floor is 9 inches thick, and the reinforcement is placed 2 inches from the lower face. What area of section of steel reinforcement is necessary per foot width if the stress in the concrete is to reach 600 lbs. per square inch, when that in the steel is 15,000 lbs. per square inch, and what load per square foot could be borne with these stresses over a span of 10 feet?

13. A concrete beam is 18 inches deep and 9 inches wide, and has to support a uniformly distributed load of 1000 lbs. per foot run over a span of 15 feet. What area of section of steel reinforcement is necessary, the bars being placed with their centres 2 inches above the lower face of the beam, if the intensity of pressure in the concrete is not to exceed 600 lbs. per square inch?

14. A ferro-concrete floor is 8 inches thick, and carries a load of 200 lbs. per square foot over a span of 12 feet. What sectional area of steel reinforcement 2 inches from the lower surface is necessary per foot width of floor if the pressure in the concrete is to be limited to 600 lbs. per square inch? What would then be the working stress in the steel?

15. Part of a concrete floor forms with a supporting beam a T section, of which the cross-piece is 30 inches wide by 6 inches deep, and the vertical leg is 8 inches wide, and is to be reinforced by bars placed with their centres 12 inches below the under side of the floor. What area of cross-section of steel will bring the neutral axis of the section in the plane of the under side of the floor? What would then be the intensity of tension in the steel when the maximum compression reaches 600 lbs. per square inch?

16. A reinforced concrete beam of T section has the cross-piece 24 inches wide and 5 inches deep, the remainder being 10 inches wide by 18 inches deep. The reinforcement consists of two 2-inch round bars placed with their centres 3 inches from the lower face of the beam. Find the intensity of tension in the steel and moment of resistance of the section when the extreme compressive stress in the concrete reaches 600 lbs. per square inch.

17. A (reinforced) flitched timber beam consists of two timber joists each 4 inches wide and 12 inches deep, with a  $\frac{1}{2}$ -inch steel plate 9 inches deep placed symmetrically between and firmly attached to them. What is the total moment of resistance of a section when the bending stress in the timber reaches 1200 lbs. per square inch, and what is the greatest intensity of stress in the steel? (E for steel may be taken 20 times that for the timber.)

18. Find the ratio of maximum to mean intensity of vertical shear stress in a cross-section of a beam of hollow circular section, the outside diameter being twice the internal diameter.

19. Find the greatest intensity of vertical shear stress on an I section 10 inches deep and 8 inches wide, flanges 0.97 inch thick, and web 0.6 inch thick, when the total vertical shear stress on the section is 30 tons. What is the ratio of the maximum to the mean intensity of vertical shear stress?

20. The section of a plate girder has flanges 16 inches wide by 2 inches thick; the web, which is 30 inches deep and  $\frac{3}{4}$  inch thick, is attached to the flanges by angles  $4 \times 4 \times \frac{5}{8}$  inch, and the section carries a vertical shearing force of 100 tons. Find approximately the intensity of vertical shear stress over all parts of the section and plot a curve showing its variation. (Neglect the rivet holes and rounded corners of the angle plate.)

21. If the above section in No. 20 is also subjected to a bending moment of 5000 ton-inches, find the principal stresses in the web 7 inches from the outer edge of the tension flange.

22. Find the moment of resistance to bending in a longitudinal plane perpendicular to the short edge which may be exerted by a beam of angle section  $6'' \times 4'' \times \frac{3}{8}''$  if the toes of the angle are rounded to a radius of  $0.3''$  and the root to a radius of  $0.425''$ , the stress being limited to 6 tons per square inch. The principal moments of inertia will be found to be  $15.209$  (inches)<sup>4</sup> and  $2.713$  (inches)<sup>4</sup> and the distances of the centroid from the short and long outer edges are  $1.912''$  and  $0.923''$  respectively. The principal axis about which the moment of inertia is a maximum is inclined to the short edge at an angle the tangent of which is  $0.439$ .

## CHAPTER VI.

### DEFLECTION OF BEAMS.

**75. Stiffness and Strength.**—It is usually necessary that a beam should be *stiff* as well as strong, *i.e.* that it should not, due to loading, deflect much from its original position. The greatest part of the deflection is generally due to bending, which produces curvature related to the intensity of stress in the manner shown in Art. 61. We now proceed to find the deflection of various parts of beams under a variety of different loadings and supported in various ways. The symbol  $y$ , a variable, will be used for deflections for different points along the neutral plane, from their original positions. This symbol is not to be confused with the variable  $y$  already used for the distances of points in a cross-section from the neutral axis of that section, although it is estimated in the same direction, usually vertical. It will be assumed that all deflections take place within the elastic limit, and are very small compared to the length of the beam.

**76. Deflection in Simple Bending: Uniform Curvature.**

—When a beam of constant section is subjected throughout its length to a uniform bending moment  $M$  it bends (see Arts. 61 and 63) to a circular arc of radius  $R$ , such that—

$$\frac{E}{R} = \frac{M}{I} \quad \text{or} \quad \frac{1}{R} = \frac{M}{EI}$$

where  $E$  is the modulus of direct elasticity, and  $I$  is the moment of inertia of the area of cross-section about the neutral axis. If a beam

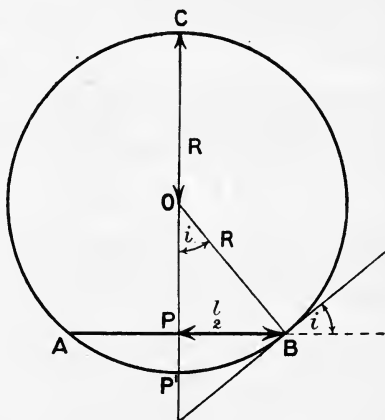

FIG. 109.

AB (Fig. 109) of length  $l$ , originally straight, bends to a circular arc  $AP'B$ , the deflection  $PP'$  or  $y$ , at the middle, can easily be found from the geometry of Fig. 109.

For  $PP' \cdot PC = PB^2 = \left(\frac{l}{2}\right)^2$   
 $PP'(2R - PP') = \frac{l^2}{4}$   
 $2PP' \cdot R - (PP')^2 = \frac{l^2}{4}$

and for small deflections, neglecting  $(PP')^2$ , the square of a small quantity—

$$2PP' \cdot R = \frac{l^2}{4}$$

$$y_1 \text{ or } PP' = \frac{l^2}{8R} = \frac{1}{8} \frac{Ml^2}{EI} \dots \dots \dots (1)$$

since  $R = \frac{EI}{M}$  (Art. 63)

In this case the whole length is subject to the maximum bending moment  $M$  as between the supports in Fig. 67. In other cases where parts of the beam are subject to less than the maximum bending moment, the factor in the above expression for maximum deflection will be less than  $\frac{1}{8}$ .

If  $i$  is the angle of slope which the ends of the beam make with the original position  $AB$ , taking  $i = \sin i$  for small deflections (in radians)—

$$i = \frac{PB}{OB} = \frac{l}{2R} = \frac{Ml}{2EI} \dots \dots \dots (2)$$

**77. Relations between Curvature, Slope, Deflections, etc.**—Measuring distances  $x$ , along the (horizontal) span from any convenient origin,  $y$  (vertical), deflections perpendicular to  $x$ ,  $i$  angles of slope in radians of the beam to some fixed direction, usually horizontal, and  $s$  lengths of arc of the profile of the neutral surface of the beam when bent (Fig. 110)—

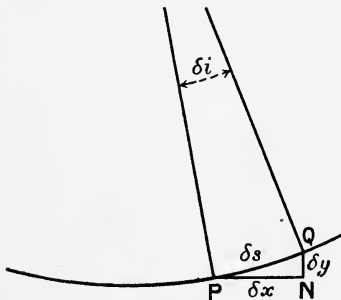

FIG. 110.

$$\frac{dy}{dx} = \tan i = i \text{ (very nearly if } i \text{ is always very small)}$$

The curvature of a line is usually defined as the change of  $i$  per unit of arc, or—

$$\frac{di}{ds}$$

and since (Fig. 110)  $\delta i$  is very small,  $\delta x$  is sensibly equal to  $\delta s$ , or  $\frac{ds}{dx} = 1$ ,

hence the curvature  $\frac{1}{R} = \frac{di}{ds} = \frac{di}{dx} = \frac{d}{dx} \left( \frac{dy}{dx} \right) = \frac{d^2y}{dx^2} \dots (1)^1$

and  $\frac{M}{EI} = \frac{1}{R} = \frac{d^2y}{dx^2} \dots (2)$

for any point  $x$  along the beam, for this relation, established for uniform curvature  $\frac{1}{R}$ , will also hold for every elementary length  $ds$  in cases

where the curvature  $\frac{1}{R}$  is variable.

Hence the slope—

$$i \text{ or } \frac{dy}{dx} = \int \frac{d^2y}{dx^2} dx = \int \frac{M}{EI} dx \dots (3)$$

the integration being between suitable limits.

And the deflection—

$$y = \int \frac{dy}{dx} dx = \int i dx \text{ or } \int \int \frac{M}{EI} dx dx \dots (4)$$

between proper limits.

Combining the above relations with those in Art. 59, viz.—

$$\frac{dM}{dx} = F \text{ and } \frac{dF}{dx} = w = \frac{d^2M}{dx^2}$$

where  $F$  is the shearing force and  $w$  is the load per unit length of span at a distance  $x$  from the origin, we have—

$$F = \frac{d}{dx} \left( EI \frac{d^2y}{dx^2} \right) = EI \frac{d^3y}{dx^3} \dots (5)$$

when  $E$  and  $I$  are constant, and

$$w = EI \frac{d^4y}{dx^4} \text{ or } \frac{d^4y}{dx^4} = \frac{w}{EI} \dots (6)$$

If  $w$  is constant or a known integrable function of  $x$ , general expressions for  $F$ ,  $M$ ,  $i$ , and  $y$  at any point of the beam may be found by one, two, three, or four integrations respectively of the equation—

$$EI \frac{d^4y}{dx^4} = w$$

a constant of integration being added at each integration. If sufficient

<sup>1</sup> The approximation may be stated in another way. The curvature—

$$\frac{1}{R} = \frac{\frac{d^2y}{dx^2}}{\left\{ 1 + \left( \frac{dy}{dx} \right)^2 \right\}^{\frac{3}{2}}}$$

and if  $\frac{dy}{dx}$  is very small, higher powers than the first may be neglected, and  $\frac{1}{R}$  reduces to  $\frac{d^2y}{dx^2}$ .

conditions of the fixing or supporting of the beam are given, the values of the constants may be determined. If the general expression for the bending moment at any point can be written as an integrable function of  $x$ , as in Art. 57, general expressions for  $i$  and  $y$  may be found by integrating twice the equation—

$$\frac{d^2y}{dx^2} = \frac{M}{EI}$$

Examples of both the above methods are given in the next article.

*Signs.*—For  $y$  positive vertically downwards slopes  $i$  or  $\frac{dy}{dx}$  will be positive downwards in the direction of  $x$  positive (generally to the right); and convexity upwards corresponds to increase of  $\frac{dy}{dx}$  with increase of  $x$ ,

*i.e.* to positive values of  $\frac{d^2y}{dx^2}$ . In Art. 59 the sign of the bending moment was so chosen that a clockwise moment of the external forces to the right was positive. Hence, if the clockwise moment of the external forces to the right of a section is written for  $M$  in equation (2) (whether positive or negative) positive curvature, *i.e.*  $+\frac{d^2y}{dx^2}$ , must be written on the other side of the equation. The same, of course, applies for the

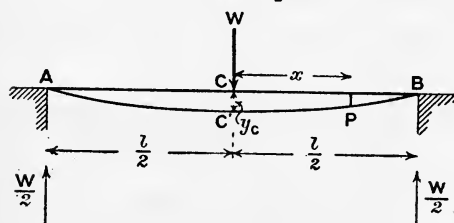

FIG. 111.

contra-clockwise moments to the left of a section. If the moments are estimated in the opposite senses to those stated  $-\frac{d^2y}{dx^2}$  must be used in equation (2). A violation of the rule of signs will lead to an error in the signs of  $i$  and  $y$  resulting from integrations of (2). It may be noted that a positive clockwise moment of external forces to the right of a section gives a positive value to  $\frac{d^2y}{dx^2}$ , *i.e.* the beam will be convex upward at that section.

**78. Uniform Beam simply supported at its Ends with Simple Loads.**—The two following examples are worked out in considerable detail to illustrate the method of finding the constants of integration.

(a) Let there be a central load  $W$  (Fig. 111), and take C as origin. Then at P, distant  $x$  horizontally along the half span CB from the origin C—

$$\frac{d^2y}{dx^2} = \frac{M}{EI} = -\frac{1}{EI} \cdot \frac{W}{2} \left( \frac{l}{2} - x \right) \quad (\text{see Fig. 63})$$

and integrating this—

$$i \text{ or } \frac{dy}{dx} = \int \frac{d^2y}{dx^2} dx = -\frac{W}{2EI} \left( \frac{l}{2}x - \frac{x^2}{2} \right) + A$$

where A is a constant.



Since  $i = 0$  when  $x = 0$ , substituting these values,  $0 = 0 + A$ , therefore  $A = 0$ ; and with this choice of origin (C)  $A$  disappears, and

$$i \text{ or } \frac{dy}{dx} = -\frac{W}{2EI} \left( \frac{l}{2}x - \frac{x^2}{2} \right) \dots \dots (1)$$

Integrating again—

$$y = \int \frac{dy}{dx} dx = -\frac{W}{2EI} \left( \frac{l}{4}x^2 - \frac{x^3}{6} \right) + B \dots \dots (2)$$

the constant of integration,  $B$ , being  $+\frac{1}{48} \frac{WL^3}{EI}$ , since  $y = 0$  when  $x = \frac{l}{2}$ . The equations (1) and (2) give the slope and deflection any-

where on the half span, e.g. at the end, or  $x = \frac{l}{2}$ ,

$$i_B = -\frac{W}{2EI} \left( \frac{l^2}{4} - \frac{l^2}{8} \right) = -\frac{WL^2}{16EI} \dots \dots (3)$$

and at the centre,  $y_C = \frac{WL^3}{48EI} \dots \dots (4)$

The slopes and deflections on the other half span are evidently of the same magnitude at the same distances from C.

(b) Let there be a uniformly spread load  $w$  per unit length. Take the origin at A (Fig. 112), and use the equation  $EI \frac{d^4y}{dx^4} = w$ . The

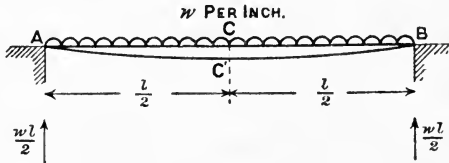

FIG. 112.

four integrations require four known conditions to evaluate the four added constants. The four conditions in this case are—

$$EI \frac{d^2y}{dx^2} = M = 0 \text{ for } x = 0$$

$$\frac{d^2y}{dx^2} = 0 \text{ for } x = l$$

$$y = 0 \text{ for } x = 0, \text{ and } y = 0 \text{ for } x = l$$

$$EI \frac{d^4y}{dx^4} = w \dots \dots (5)$$

Integrating,  $EI \frac{d^3y}{dx^3} = wx + A \dots \dots (6)$

Integrating again,  $EI \frac{d^2y}{dx^2} = \frac{1}{2}wx^2 + Ax + 0$

the added constant being zero, since both sides must reduce to 0 for  $x = 0$ .

Putting  $\frac{d^2y}{dx^2} = 0$  when  $x = l$

$$0 = \frac{1}{2}wl^2 + Al$$

$$A = -\frac{1}{2}wl$$

hence

(a result which might also be obtained from (6), since the shearing force is zero for  $x = \frac{l}{2}$ ).

Then substituting for A—

$$EI \cdot \frac{d^2y}{dx^2} = \frac{1}{2}wx^2 - \frac{1}{2}wlx \quad \dots \quad (7)$$

Integrating this—

$$i = \frac{dy}{dx} = \frac{1}{EI} \left( \frac{1}{6}wx^3 - \frac{1}{4}wlx^2 + B \right) \quad \dots \quad (8)$$

Integrating again—

$$y = \frac{1}{EI} \left( \frac{1}{24}wx^4 - \frac{1}{12}wlx^3 + Bx + C \right)$$

the constant being zero, since  $y = 0$  for  $x = 0$ .

Putting

$$\begin{aligned} y &= 0 \text{ for } x = l \\ 0 &= \frac{1}{24}wl^4 - \frac{1}{12}wl^3 + Bl \\ \text{therefore } B &= \frac{1}{24}wl^3 \end{aligned}$$

which might also be found from (8), since by symmetry  $i = 0$  for  $x = \frac{l}{2}$ ,

$$\begin{aligned} \text{and } y &= \frac{1}{EI} \left( \frac{1}{24}wx^4 - \frac{1}{12}wlx^3 + \frac{1}{24}wl^3x \right) \\ \text{or, } y &= \frac{wx}{24EI} (x^3 - 2lx^2 + l^3) \\ \text{or, } y &= \frac{wx(l-x)}{24EI} (l^2 + lx - x^2) \end{aligned} \quad \dots \quad (9)$$

(6), (7), (8), and (9) give F, M,  $i$ , and  $y$  respectively for any point distant  $x$  along the beam from the end A. E.g.  $i$  is a maximum when  $\frac{di}{dx} = 0$  or  $M = 0$ , *i.e.* at the ends; thus, writing  $x = 0$  in (8)—

$$i_A = \frac{B}{EI} = \frac{wl^3}{24EI} \quad \dots \quad (10)$$

$y$  is a maximum when  $\frac{dy}{dx}$  or  $i = 0$ , *i.e.* when  $x = \frac{l}{2}$ ,

$$\text{and then } y_C = \frac{wl^4}{24EI} \left( \frac{1}{16} - \frac{1}{4} + \frac{1}{2} \right) = \frac{5}{384} \frac{wl^4}{EI} \quad \dots \quad (11)$$

or, if the whole load  $wl = W$ —

$$y_C = \frac{5}{384} \cdot \frac{Wl^3}{EI} \quad \dots \quad (12)$$

The signs here all agree with and illustrate the convention given at the end of Arts. 59 and 77.

*Overhanging Ends.*—For points between two supports a distance  $l$  apart the work would be just as before, except that  $EI \frac{d^2y}{dx^2}$  at each support would be equal to the bending moment due to the overhanging end instead of zero.

*Propped Beam.*—If this beam were propped by a central support to the same level as the ends, the central deflection becomes zero, or, in other words, the upward deflection caused by the reaction of the prop (and proportional to it) is equal to the downward deflection caused by the load at the middle of the span.

Let  $P$  be the upward reaction of the prop; then from (4) and (11)—

$$\frac{Pl^3}{48EI} = \frac{5}{384} \frac{wl^4}{EI} \dots \dots \dots (13)$$

and  $P = \frac{5}{8}wl$ , *i.e.* the central prop carries  $\frac{5}{8}$  of the whole load, while the end supports each carry  $\frac{3}{16}$  of the load.

*Sinking of Prop.*—If the prop is not level with the end supports, but removes  $\frac{1}{n}$  of the deflection due to the downward load, the reaction of the prop will be  $\frac{1}{n}$  of the above amount.

*Elastic Prop.*—If the central prop and end supports were originally at the same level, but were elastic and such that the pressure required to depress each unit distance is  $e$ , the compression of the prop is  $\frac{P}{e}$ , and of each end support  $\frac{wl - P}{2e}$ . Then equating the difference of levels to the downward deflection due to the load, minus the upward deflection due to  $P$ —

$$\begin{aligned} \frac{P}{e} - \frac{wl - P}{2e} &= \frac{5}{384} \frac{wl^4}{EI} - \frac{Pl^3}{48EI} \\ P \left( \frac{3}{2e} + \frac{l^3}{48EI} \right) &= wl \left( \frac{5}{384} \frac{l^3}{EI} + \frac{1}{2e} \right) \\ P &= wl \frac{\frac{5}{8} + \frac{24EI}{el^3}}{1 + \frac{72EI}{el^3}} \dots \dots \dots (14) \end{aligned}$$

which evidently reduces to the previous result for perfectly rigid supports for which  $e$  is infinite, and approaches  $\frac{1}{3}wl$  for very elastic supports. If the elasticities of the end supports and central prop are different, the modification in the above would be simple.

EXAMPLE 1.—A beam of 10 feet span is supported at each end and carries a distributed load which varies uniformly from nothing at one support to 4 tons per foot run at the other. The moment of inertia of the cross-section being 375 (inches)<sup>4</sup>, and  $E$  13,000 tons per

square inch, find the slopes at each end and the magnitude and position of the maximum deflection.

The conditions of the ends are as before. Take the origin at the light end; then at a distance  $x$  inches along the span the load per inch run is—

$$\begin{aligned} \frac{x}{120} \times \frac{4}{12} &= \frac{x}{360} \text{ tons} \\ \frac{d^4 y}{dx^4} &= \frac{1}{360EI} \cdot x \\ \frac{d^3 y}{dx^3} &= \frac{1}{360EI} \left( \frac{x^2}{2} + A \right) \\ \frac{d^2 y}{dx^2} &= \frac{1}{360EI} \left( \frac{x^3}{6} + Ax + 0 \right) \\ \frac{d^2 y}{dx^2} &= 0 \text{ for } x = l; \text{ hence } A = -\frac{l^2}{6} \text{ and} \\ \frac{d^2 y}{dx^2} &= \frac{1}{360EI} \left( \frac{x^3}{6} - \frac{l^2 x}{6} \right) \\ \frac{dy}{dx} &= \frac{1}{360EI} \left( \frac{x^4}{24} - \frac{l^2 x^2}{12} + B \right) \\ y &= \frac{1}{360EI} \left( \frac{x^5}{120} - \frac{l^2 x^3}{36} + Bx + 0 \right) \end{aligned}$$

$y = 0$  for  $x = l$ ; hence—

$$\begin{aligned} B &= \frac{l^4}{36} - \frac{l^4}{120} = \frac{7l^4}{360} \\ \frac{dy}{dx} &= \frac{1}{360EI} \left( \frac{x^4}{24} - \frac{l^2 x^2}{12} + \frac{7l^4}{360} \right) \end{aligned}$$

and

$$y = \frac{1}{360EI} \left( \frac{x^5}{120} - \frac{l^2 x^3}{36} + \frac{7l^4 x}{360} \right)$$

At the light end  $x = 0$

$$\frac{dy}{dx} = \frac{7 \times 120^4}{360} \times \frac{1}{360 \times 13,000 \times 375} \text{ radians} = 0.131^\circ$$

At the heavy end  $x = 120$  inches,  $\frac{dy}{dx} = 0.150^\circ$

At the point of maximum deflection  $\frac{dy}{dx} = 0$ ; therefore—

$$\frac{x^4}{24} - \frac{l^2 x^2}{12} + \frac{7}{360} l^4 = 0$$

hence, solving

$$x = 0.52l = 62.4 \text{ inches}$$

and substituting this value,

$$y = 0.0925 \text{ inch}$$

EXAMPLE 2.—A wooden plank 12 inches wide, 4 inches deep, and 10 feet long, is suspended from a rigid support by three wires, each of

which is  $\frac{1}{3}$  of a square inch in section and 15 feet long, one being at each end, and one midway between them. All the wires being just drawn up tight, a uniform load of 400 lbs. per foot run is placed on the plank. Neglecting the weight of the wood, find the tension in the central and end wires, and the greatest intensity of bending stress in the plank, the direct modulus of elasticity (E) for the wires being 20 times that for the wood.

Let  $E_s$  be the modulus for the wires, and  $E_w$  that for the wood =  $\frac{1}{20}E_s$ . The force per inch stretch of the wires ( $e$ ) =  $\frac{E_s}{8 \times 180}$ , the strain being  $\frac{1}{180}$ . For the wooden beam supported at the centre,

$$I = \frac{1}{12} \times 12 \times 64 = 64 \text{ (inches)}^4$$

The load on the central wire may be found from (14) above—

$$\frac{24E_w I}{e l^3} = \frac{24E_w \times 64 \times 8 \times 180}{E_s \times 120 \times 120 \times 120} = 0.064$$

hence, by (14) the total tension in the middle wire is—

$$P = 4000 \times \frac{0.625 + 0.064}{1 + (3 \times 0.064)} = 4000 \times 0.578 = 2312 \text{ lbs.}$$

In each end wire, total pull =  $\frac{4000 - 2312}{2} = 844 \text{ lbs.}$

The greatest bending moment may occur at the middle support, where the diagram is discontinuous, or as a mathematical maximum between the end and the middle of the beam.

At  $x$  inches from one end—

$$M = 844x - \frac{1}{2} \cdot \frac{400}{12} \cdot x^2$$

$$\frac{dM}{dx} = 844 - \frac{100}{3}x$$

which is zero for  $x = 25.32$  inches.

Substituting this for  $x$ —

$$M = 21,370 - 10,685 = 10,685 \text{ lb.-inches}$$

At the middle of the span—

$$M = (844 \times 60) - (2000 \times 30) = -9360 \text{ lb.-inches}$$

this being less than that at  $x = 25.32$  inches.

The greatest intensity of bending stress is—

$$\frac{My_1}{I} = \frac{10,685 \times 2}{64} = 334 \text{ lbs. per square inch}$$

**79. Uniform Cantilever simply loaded.**—(a) A concentrated load  $W$  at the free end. Take the origin  $O$  (Fig. 113) at the fixed end.

Then for  $x = 0$ ,  $\frac{dy}{dx} = 0$ , and  $y = 0$ .

At any point  $x$  the bending moment—

$$EI \cdot \frac{d^2y}{dx^2} = W(l - x)$$

$$EI \frac{dy}{dx} = W(lx - \frac{1}{2}x^2) + c$$

$$EI \cdot y = W(\frac{1}{2}lx^2 - \frac{1}{6}x^3) + c_1$$

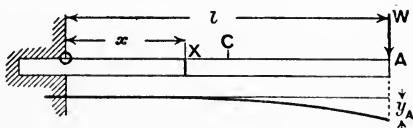

FIG. 113.

At the end A—

$$\left(\frac{dy}{dx}\right)_A \text{ or } i_A = \frac{W}{EI}(l^2 - \frac{1}{2}l^2) = \frac{Wl^2}{2EI} \dots (1)$$

and

$$y_A = \frac{Wl^3}{EI}(\frac{1}{2} - \frac{1}{6}) = \frac{Wl^3}{3EI} \dots (2)$$

Note that the upward deflection of the support relative to the centre of the beam in Fig. 113 might be found from the formula (2), viz.—

$$\frac{W}{2} \cdot \left(\frac{l}{2}\right)^3 = \frac{Wl^3}{48EI} \text{ (as in (4), Art. 78)}$$

(b) A concentrated load distant  $l_1$  from the fixed end. Origin at O (Fig. 114) at the fixed end, all conditions as above.

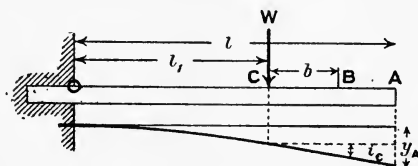

FIG. 114.

From O to C

$$EI \frac{d^2y}{dx^2} = W(l_1 - x)$$

$$EI \frac{dy}{dx} = W(l_1x - \frac{1}{2}x^2) + c$$

$$EI \cdot y = W(\frac{1}{2}l_1x^2 - \frac{1}{6}x^3)$$

At C

$$\left(\frac{dy}{dx}\right)_c \text{ or } i_c = \frac{Wl_1^2}{2EI} \text{ (as before)} \dots (3)$$

and

$$y_c = \frac{Wl_1^3}{3EI} \dots (4)$$

At any point B beyond C the slope remains the same as at C, and the deflection at B exceeds that at C by—

$$b \times (\text{slope from C to B}) = b \cdot \frac{Wl_1^3}{2EI}$$

In particular—

$$y_A = \frac{Wl_1^3}{3EI} + (l - l_1) \frac{Wl_1^3}{2EI} \dots \dots \dots (5)$$

The same formula would be applicable to any number of loads. The equation of upward and downward deflections as used in the previous article may be used to find the load taken by a prop at the free end or elsewhere.

(c) Uniformly distributed load  $w$  per unit length. Origin O (Fig. 115)

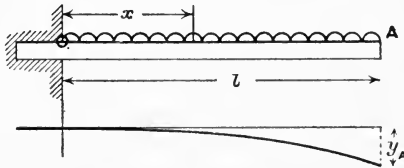

FIG. 115.

at the fixed end. A start may be made from relation (2) or (6) of Art. 77. Selecting the former—

$$M = EI \frac{d^2y}{dx^2} = \frac{w}{2}(l - x)^2 = \frac{wl}{2}(l^2 - 2lx + x^2)$$

$$EI \frac{dy}{dx} = \frac{wl}{2}(l^2x - lx^2 + \frac{1}{3}x^3) + c$$

$$EI \cdot y = \frac{wl}{2}(\frac{1}{2}l^2x^2 - \frac{1}{3}lx^3 + \frac{1}{12}x^4) + cx + d$$

For  $x = l$ —

$$i_A \text{ or } \left(\frac{dy}{dx}\right)_A = \frac{wl^3}{2EI} \left(1 - 1 + \frac{1}{3}\right) = \frac{1}{6} \frac{wl^3}{EI} \text{ or } \frac{1}{6} \frac{Wl^3}{EI} \dots (6)$$

where  $W = wl$ .

$$y_A = \frac{wl^4}{2EI} \left(\frac{1}{2} - \frac{1}{3} + \frac{1}{12}\right) = \frac{1}{8} \frac{wl^4}{EI} \text{ or } \frac{1}{8} \cdot \frac{Wl^4}{EI} \dots \dots (7)$$

The result (12), Art. 78, might be deduced from the above, for the upward deflection of the support relative to the centre of the beam is—

$$\frac{\frac{wl}{2} \cdot \left(\frac{l}{2}\right)^3}{3EI} - \frac{w \left(\frac{l}{2}\right)^4}{8EI} = \frac{5}{384} \cdot \frac{wl^4}{EI}$$

*Propped Cantilever.*—From (2) and (7) it is evident, by equating upward and downward deflections, that a prop at the free end level with

the fixed end, when loaded, would carry  $\frac{3}{8}$  of the whole distributed load. The bending-moment diagram may be drawn by superposing diagrams such as Fig. 59 and Fig. 61, making  $W = \frac{3}{8}wl$ , and taking the difference of the ordinates as representing the resulting bending moments. The curve of shearing force is a straight line similar to that of Fig. 61, but raised throughout by an amount  $\frac{3}{8}wl$  relative to the base-line. Other types of loading of propped cantilevers may be dealt with on similar principles. The reader should work out this simple case fully as an exercise, noting the points of maximum deflection, contraflexure, etc.,

by integration of the equation  $EI \frac{d^4y}{dx^4} = w$ , the conditions being  $y = 0$  at both ends, slope = 0 at the fixed end, and  $\frac{d^2y}{dx^2} = 0$  at the free end.

*Sinking Prop.*—If the prop is below the level of the fixed end, the load carried by it would be proportionately reduced. If it is above that level, the load on it would be proportionally increased.

*Elastic Prop.*—If the fixed end is rigid and the support at the free end is elastic, requiring a force  $e$  per unit of depression and being before loading at the same level as the fixed end, for the above simple case of distributed load, equating the depression of the prop to the difference of deflections due to the load and the prop—

$$\frac{P}{e} = \frac{1}{8} \frac{wl^4}{EI} - \frac{Pl^3}{3EI}$$

whence

$$P = wl \left( \frac{\frac{3}{8}}{1 + \frac{3EI}{el^3}} \right)$$

For other types of loading or positions of prop, similar principles would hold good.

(d) Partial distributed load.

If the load only extended a distance  $l_1$  from the fixed end, the deflection at the free end would be, by the method employed in (5) above—

$$y = \frac{wl_1^4}{8EI} + (l - l_1) \frac{1}{8} \cdot \frac{wl_1^3}{EI} \dots \dots \dots (8)$$

If the load extended from the free end to a distance  $l_1$  from the fixed end, the deflection of the free end would be found by subtracting (8) from (7).

EXAMPLE 1.—A cantilever carries a concentrated load  $W$  at  $\frac{3}{4}$  of its length from the fixed end, and is propped at the free end to the level of the fixed end. Find what proportion of the load is carried on the prop.

Let  $W$  be the load, and  $P$  the pressure on the prop. Then—

$$\begin{aligned} \frac{1}{8} \frac{Pl^3}{EI} &= \frac{1}{8} \frac{W(\frac{3}{4}l)^3}{EI} + \frac{1}{4}l \cdot \frac{W(\frac{3}{4}l)^2}{2EI} \\ \frac{1}{8}P &= W \left( \frac{9}{64} + \frac{9}{128} \right) = \frac{27}{128}W \\ P &= \frac{81}{128}W \end{aligned}$$



EXAMPLE 2.—A cantilever 10 feet long carries a uniformly spread load over 5 feet of its length, running from a point 3 feet from the fixed end to a point 2 feet from the free end, which is propped to the same level as the fixed end. Find what proportion of the load is carried by the prop.

Let  $w$  = load per foot run, and  $P$  = pressure on the prop. The total load is  $\frac{1}{2}wl$ . Deflection of the free end if unpropped would be—

$$\frac{1}{8} \frac{w(0.8l)^4}{EI} + 0.2l \cdot \frac{1}{6} \frac{w(0.8l)^3}{EI} - \left\{ \frac{1}{8} \frac{w(0.3l)^4}{EI} + 0.7l \cdot \frac{1}{6} \frac{w(0.3l)^3}{EI} \right\}$$

$$= \frac{wl^4}{EI} \left\{ \frac{0.4096}{8} + \frac{0.1024}{6} - \frac{0.0081}{8} - \frac{0.0189}{6} \right\} = 0.0641 \frac{wl^4}{EI}$$

Therefore

$$\frac{1}{8} \frac{Pl^3}{EI} = 0.0641 \frac{wl^4}{EI}$$

$$P = 0.1923wl \text{ or } 0.385 \text{ of the total load}$$

Note that this is less than half the load, although the centre of gravity of the load is nearer to the propped end.

EXAMPLE 3.—A cantilever of uniform cross-section carries a load which varies uniformly from a maximum  $w$  per foot run at the fixed end to zero at the free end. If the free end is propped to the level of the fixed end, find the load carried by the prop.

This might be solved by the methods of the two previous exercises, first finding the deflection if unpropped, or by direct integration. Using the latter method, let the origin be at the fixed end.

$$EI \frac{d^4y}{dx^4} = w \cdot \frac{l-x}{l} = w \left( 1 - \frac{x}{l} \right)$$

$$EI \frac{d^3y}{dx^3} = w \left( x - \frac{1}{2} \frac{x^2}{l} + A \right)$$

$$EI \frac{d^2y}{dx^2} = w \left( \frac{1}{2} x^2 - \frac{1}{6} \frac{x^3}{l} + Ax + B \right)$$

$$\frac{d^2y}{dx^2} = 0 \text{ for } x = l.$$

Substituting these values,  $B = \frac{1}{6}l^2 - \frac{1}{2}l^2 - Al = -\frac{1}{3}l^2 - Al$ , and—

$$EI \frac{d^2y}{dx^2} = w \left( \frac{1}{2}x^2 - \frac{1}{6} \frac{x^3}{l} + Ax - \frac{1}{3}l^2 - Al \right)$$

$$\frac{dy}{dx} = \frac{w}{EI} \left( \frac{1}{6}x^3 - \frac{1}{24} \frac{x^4}{l} + \frac{1}{2}Ax^2 - \frac{1}{3}l^2x - Alx + 0 \right)$$

$$y = \frac{w}{EI} \left( \frac{1}{24}x^4 - \frac{1}{120} \frac{x^5}{l} + \frac{1}{6}Ax^3 - \frac{1}{6}l^2x^2 - \frac{1}{2}Alx^2 + 0 \right)$$

Since  $y = 0$  for  $x = l$ ,  $A \left( -\frac{1}{6} + \frac{1}{2} \right) = l \left( \frac{1}{24} - \frac{1}{120} - \frac{1}{6} \right) = -\frac{2}{15}l$ , and  $A = -\frac{2}{15}l$ , hence—

$$EI \frac{d^3y}{dx^3} = w \left( x - \frac{1}{2} \frac{x^2}{l} - \frac{2}{15}l \right)$$

which gives the shearing force anywhere, and at the free end  $x = l$ , and the shearing force is—

$$wl\left(1 - \frac{1}{2} - \frac{2}{5}\right) = \frac{1}{10}wl$$

which is the reaction at the free end.

The total load is  $\frac{1}{2}wl$ , hence the proportion carried at the free end is  $\frac{1}{5}$  of the whole. If both ends were free it would be  $\frac{1}{3}$ .

**EXAMPLE 4.**—A bar of steel 2 inches square is bent at right angles 3 feet from one end; the other and longer arm is firmly fixed vertically in the ground, the short (3-foot) arm being horizontal and 10 feet above the ground. A weight of  $\frac{1}{4}$  ton is hung from the end of the horizontal arm. Find the horizontal and vertical deflection of the free end.  $E = 13,000$  tons per square inch.

The bending moment throughout the long arm is sensibly the same as that at the bend, viz.  $\frac{1}{4} \times 36 = 9$  ton-inches.

It therefore bends to a circular arc, the lower end remaining vertical. A line joining the two ends of the long arm would therefore make with the vertical an angle—

$$\frac{Ml}{2EI} \text{ (Art. 76 (2))} = \frac{9 \times 120}{2EI} = \frac{9 \times 120 \times 12}{2 \times 13,000 \times 16} = \frac{81}{2600} \text{ radians}$$

and the horizontal deflection of the whole of the short arm will be—

$$\frac{81}{2600} \times \frac{120}{1} = \frac{243}{65} = 3.74 \text{ inches}$$

The inclination of the upper end of the long arm to the vertical is evidently twice the amount  $\frac{81}{2600}$ , which is the average inclination. The downward slope of the short cantilever arm is therefore  $\frac{81}{1300}$  at the bend. The total vertical deflection at the free end is—

$$36 \times \frac{81}{1300} + \frac{1}{4} \times \frac{36 \times 36 \times 36 \times 12}{3 \times 13,000 \times 16} = 2.243 + 0.224 = 2.467 \text{ inches}$$

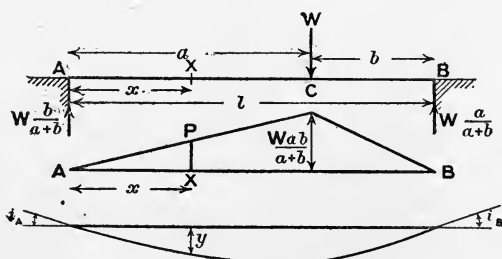

FIG. 116.

**80. Simply supported Beam with Non-central Load.**—Let  $W$  be a load concentrated at a distance  $a$  from one support  $A$  (Fig. 116), and  $b$

from the other support, B, the span being  $a + b = l$ . The Reaction  $R_A$  at A is evidently—

$$\frac{b}{a + b} \cdot W \quad \text{and} \quad R_B = \frac{a}{a + b} \cdot W$$

Suppose that  $a$  is greater than  $b$ . Taking A as origin, from A to C

$$\frac{d^2y}{dx^2} = -\frac{W}{EI} \frac{b}{a + b} \cdot x \quad \dots \dots \dots (1)$$

$$\frac{dy}{dx} = -\frac{Wb}{EI(a + b)} \cdot \frac{x^2}{2} + A$$

and at C  $\frac{dy}{dx}$  or  $i_c = -\frac{Wb}{EI(a + b)} \cdot \frac{a^2}{2} + A$

or,  $A = i_c + \frac{Wba^2}{2EI(a + b)}$

and  $\frac{dy}{dx} = -\frac{Wb}{EI(a + b)} \cdot \frac{x^2}{2} + i_c \quad \dots \dots \dots (2)$

$$y = -\frac{Wb}{EI(a + b)} \left( \frac{x^3}{6} - \frac{a^2x}{2} \right) + i_c \cdot x + o \quad \dots \dots \dots (3)$$

and at C, where  $x = a$ —

$$y_c = \frac{Wb}{EI(a + b)} \cdot \frac{a^3}{3} + a \cdot i_c \quad \dots \dots \dots (4)$$

Similarly, taking B as origin and measuring  $x$  as positive towards C, making  $i_c$  of opposite sign—

$$y_c = \frac{Wa}{EI(a + b)} \cdot \frac{b^3}{3} - b \cdot i_c \quad \dots \dots \dots (5)$$

Subtracting (5) from (4)—

$$(a + b) \cdot i_c = -\frac{Wab(a^2 - b^2)}{3EI(a + b)}$$

and  $i_c = -\frac{Wab(a - b)}{3E(a + b)} \quad \dots \dots \dots (6)$

Substituting this value of  $i_c$  in (3)—

$$y = -\frac{Wb}{EI(a + b)} \left( \frac{x^3}{6} - \frac{a^2x}{6} - \frac{abx}{3} \right) = \frac{Wbx}{EI(a + b)} \cdot \frac{a^2 + 2ab - x^2}{6} \quad (7)$$

and at C, when  $x = a$  under load—

$$y_c = \frac{Wa^2b^2}{3EI(a + b)} \quad \dots \dots \dots (8)$$

The maximum deflection occurs where  $\frac{dy}{dx} = 0$ . Substituting for  $i_0$  in (2), or differentiating (7)—

$$\frac{dy}{dx} = -\frac{Wb}{EI(a+b)}\left(\frac{x^2}{2} - \frac{a^2}{6} - \frac{ab}{3}\right) \dots (2a)$$

and when  $\frac{dy}{dx} = 0$

$$x^2 = \frac{1}{3}a(a+2b)$$

$$x = \frac{l}{\sqrt{3}} \cdot \sqrt{a^2 + 2ab} \text{ or } \frac{l}{\sqrt{3}} \cdot \sqrt{l^2 - b^2}$$

which gives the value of  $x$  where the deflection  $y$  is a maximum.

Note that this value of  $x$  is always less than  $a$  if  $b$  is less than  $a$ . A corresponding expression for the other part of the span would not hold, for  $x$  is then greater than  $b$ ;  $\frac{dy}{dx}$  is not zero within the smaller segment  $b$ .

Also note that as  $b$  varies from  $\frac{1}{2}l$  to zero, the position ( $x$ ) of maximum deflection only varies from  $\frac{1}{2}l$  to  $\frac{l}{\sqrt{3}}$ , or  $0.577l$ , so that the point of maximum deflection is always within 8 per cent. of the length of the beam from the middle. Substituting the above value of  $x$  in (7)—

$$y_{\max.} = \frac{Wb(a^2 + 2ab)^{\frac{2}{3}}}{9\sqrt{3}EI(a+b)} \text{ or } \frac{Wb(l^2 - b^2)^{\frac{2}{3}}}{9\sqrt{3}E \cdot I \cdot l} \dots (9)$$

Within the smaller segment  $b$  the deflection at any point distant  $(a+b-x)$ , or, say  $x'$  (less than  $b$ ), from B, the deflection corresponding to (7) will be—

$$y = \frac{Wax'}{EI(a+b)} \cdot \frac{b^2 + 2ab - x'^2}{6} \dots (10)$$

and corresponding to (2a)

$$\frac{dy}{dx'} \text{ or } i = \frac{Wa}{EI(a+b)}\left(\frac{x'^2}{2} - \frac{b^2}{6} - \frac{ab}{3}\right) \dots (11)$$

which is never zero when  $x'$  is less than  $b$ .

*Several Loads.*—If there are several concentrated loads on one span the deflection at any selected point, whether directly under a load or not, may be found by adding the deflections due to the several loads as calculated by (7) or (10) above, using (7) for points in major segments, and (10) for points in minor ones, the origins being chosen for each load so that the selected point is between the origin and the load.

The slope between any two loads might be written down in terms of  $x$ , the distance from A, by using the sum of such terms as (2a) and (11), writing  $(a + b - x)$  instead of  $x'$ . If this sum vanishes for any value of  $x$  lying between the two chosen loads, that value of  $x$  gives the position of the maximum deflection. If not, the maximum lies between another pair of loads. The pair between which the maximum deflection lies can usually be determined by inspection, from the fact noted above, that every individual load causes its maximum deflection within a short distance of the mid-span. A simpler method is given in Art. 81.

EXAMPLE.—A beam of 20-foot span is freely supported at the ends, and is propped 9 feet from the left-hand end to the same level as the supports, thus forming two spans of 9 and 11 feet. The beam carries a load of 3 tons 5 feet from the left-hand support, and one of 7 tons 4 feet from the right-hand end. Find the reactions at the prop and at the end supports.

If the beam were not propped, the deflection at C (Fig. 117), 9 feet

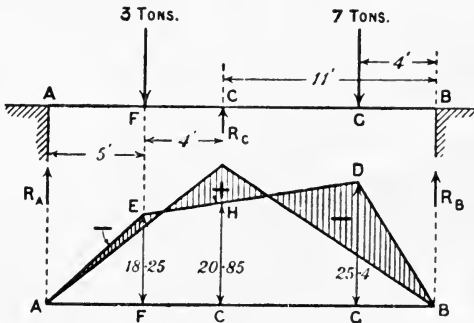

FIG. 117.

from A, would be, for the 3-ton load, taking  $a = 5$ ,  $b = 15$ ,  $W = 3$  and  $x' = 11$ , in (10) above—

$$y_c = \frac{3 \times 5 \times 11}{20EI} \left\{ \frac{225 + (10 \times 15) - 121}{6} \right\} = \frac{349.25}{EI}$$

and for the 7-ton load, taking  $a = 16$ ,  $b = 4$ ,  $W = 7$ ,  $x = 9$ , in (7)—

$$y_c = -\frac{7 \times 4}{20EI} \left\{ \frac{729 - (256 \times 9) - (2 \times 16 \times 4 \times 9)}{6} \right\} = \frac{636.3}{EI}$$

Adding these, the downward deflection of the beam would be, if it were not propped—

$$\frac{985.55}{EI}$$

If  $R_c$  is the reaction of the prop at C, the upward deflection is, by (8) above—

$$y_c = \frac{R_c \times 81 \times 121}{3EI \times 20} = \frac{163.35R_c}{EI}$$

Equating this to the above deflection at C—

$$R_c = \frac{985.5}{163.35} = 6.031 \text{ tons}$$

The reactions at A and B follow by taking moments about the free ends.

$$R_B = \frac{(3 \times 5) + (7 \times 16) - (6.03 \times 9)}{20} = 3.636 \text{ tons}$$

$$R_A = 10 - 6.031 - 3.635 = 0.334 \text{ ton}$$

### 81. Deflection and Slope from Bending-moment Diagrams.

*Slopes.*—The change of slope between any two points on a beam may be found from the relation shown in (3), Art. 77—

$$i \text{ or } \frac{dy}{dx} = \int \frac{d^2y}{dx^2} \cdot dx = \int \frac{M}{EI} dx = \frac{1}{EI} \int M dx$$

if E and I are constant.

Between two points P and Q (Fig. 118, in which the slopes and deflections are greatly exaggerated), on a beam of constant cross-

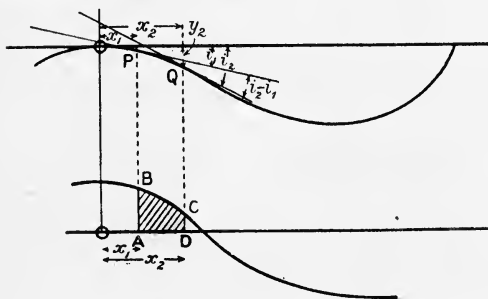

FIG. 118.

section, the change of inclination  $i_2 - i_1$ , which is the angle between the two tangents at P and Q, may be represented by—

$$i_2 - i_1 = \frac{1}{EI} \int_{x_1}^{x_2} M dx \quad (1)$$

The quantity  $\int_{x_1}^{x_2} M dx$  represents the area ABCD of the bending-moment diagram between

P and Q. If the lower limit  $x_1$  be zero, from O, where the beam is horizontal, to Q, where the slope is  $i_2$ , the actual slope is equal to the change of inclination, viz.—

$$i_2 = \frac{1}{EI} \int_0^{x_2} M dx \text{ (which is proportional to OECD) } . \quad (2)$$

Thus the change of slope between two points on a beam is proportional to the area of the bending-moment diagram between them, and from a point of zero slope to any other point the area under the bending-moment curve is proportional to the actual slope at the second point. Changes of sign in the bending-moment diagram must be taken into account if the curve passes through zero. One algebraic sign, generally positive, is attached to bending, which produces convexity upwards, and the opposite sign to a bending moment, producing convexity downwards (see Art. 77), but the choice is of little importance in the present chapter.

*Scales.*—If in the bending-moment diagram 1 inch horizontally represents  $q$  inches, and 1 inch vertically represents  $s$  lb.-inches, 1 square inch of bending-moment diagram area represents  $q \cdot s$  lb.-inches<sup>2</sup>, and also represents  $\frac{q \cdot s}{EI}$  radians slope if  $E$  is in pounds per square inch and  $I$  in (inches)<sup>4</sup> units.

*Deflection.*—From the equation—

$$\frac{d^2y}{dx^2} = \frac{M}{EI} \quad ((2), \text{Art. 77})$$

$$x \frac{d^2y}{dx^2} = \frac{Mx}{EI}$$

Integrating between  $x = x_2$  and  $x = x_1$ , using the method of integration by parts for the left-hand side—

$$\left( x \frac{dy}{dx} - y \right)_{x=x_1}^{x=x_2} = \int_{x_1}^{x_2} \frac{Mx}{EI} dx = \frac{1}{EI} \int_{x_1}^{x_2} Mx dx \quad (\text{if } EI \text{ is constant}) \quad (3)$$

$$\text{or,} \quad (x_2 i_2 - y_2) - (x_1 i_1 - y_1) = \frac{1}{EI} \int_{x_1}^{x_2} Mx dx \quad . . . \quad (4)$$

If the limits of integration between which the deflection is required are such that  $x \frac{dy}{dx}$  is zero (from either of the factors  $x$  or  $\frac{dy}{dx}$  being zero) at each limit, the expression—

$$\left( x \frac{dy}{dx} - y \right)_{x=x_1}^{x=x_2} \text{ becomes } -(y_2 - y_1) \quad . . . \quad (5)$$

and  $\frac{1}{EI} \int_{x_1}^{x_2} Mx dx$  gives the change in level of the beam between the two points.

The quantity—

$$\int_{x_1}^x Mx dx$$

represents the moment *about the origin* of the area of the bending-moment diagram between  $x_2$  and  $x_1$ . If  $A$  is this area and  $\bar{x}$  is the distance of its centre of gravity or centroid from the origin,  $\int_{x_1}^{x_2} Mx dx$  may be represented by  $A \cdot \bar{x}$ .

This quantity only represents the change in level when  $x \cdot \frac{dy}{dx}$  vanishes at *both limits*. The product  $x \cdot \frac{dy}{dx}$  or  $x \cdot i_x$  denotes the vertical projection of the tangent at  $x$ , the horizontal projection of which is  $x$ . If the lower limit is zero, and  $y$  is zero at the origin, the quantity—

$$\left( x \cdot \frac{dy}{dx} - y \right)_0^x$$

represents the difference between the vertical projection of the tangent at  $x$ , over a horizontal length  $x$ , and the deflection at  $x$ ; in other words, the vertical deflection of the beam from its tangent. Hence, in this case, the deflection at a distance  $x$  from the origin is equal to the difference between  $x \cdot i_x$  and  $\frac{I}{EI} \times$  (moment of bending-moment diagram area), or—

$$x \cdot i_x - \frac{I}{EI} \int_0^x Mx dx \dots \dots \dots (4a)$$

where  $\int_0^x Mx dx$  may be either positive or negative.

*Scales.*— $i$  in the bending-moment diagram 1 inch (horizontally) represents  $q$  inches, and 1 inch (vertically) represents  $s$  lb.-inches,  $A$  being measured in square inches and  $\bar{x}$  in inches, the product  $A \cdot \bar{x}$  represents the deflection on a scale  $\frac{q^2 s}{EI}$  inches to 1 inch.

*Applications:* (a) *Cantilever with Load W at the Free End* (see Fig. 59).—If the origin be taken at the free end before or after deflection—

$$\text{for } x = 0 \quad x \frac{dy}{dx} = 0$$

and at the fixed end  $x = l$  and  $\frac{dy}{dx} = 0$ , hence—

$$\left( x \cdot \frac{dy}{dx} - y \right)_0^l$$

gives the difference of level of the two ends  $y_0 - y_l$ , which is equal to—

$$\frac{A \cdot \bar{x}}{EI}$$

where  $A = \frac{1}{2} \cdot Wl \cdot l$  and  $\bar{x} = \frac{2}{3}l$ .

So that the deflection is—

$$\frac{1}{2} Wl^2 \times \frac{2}{3}l \div EI = \frac{Wl^3}{3EI}$$

which agrees with (2), Art. 79.

Similarly, if the load is at a distance  $l_1$  from the fixed end,  $A = \frac{1}{2} Wl_1^2$ ,  $\bar{x} = l - \frac{1}{3}l_1$ , and the deflection of the free end is—

$$\frac{1}{2} \frac{Wl_1^2}{EI} \left( l - \frac{1}{3}l_1 \right) = \frac{Wl_1^2 l}{2EI} - \frac{Wl_1^3}{6EI}$$

which agrees with (5), Art. 79, and might be applied to the case of any number of isolated loads.

The deflection of a cantilever carrying a uniformly distributed load might similarly be found from the diagram of bending moment (Fig. 61) if the distance of the centroid of the parabolic spandril of Fig. 61 from



the free end is known. Otherwise the moment of that area may be found by integration. Taking the origin at A (Fig. 61)—

$$\frac{1}{EI} \int_0^l Mx dx = \frac{w}{2EI} \int_0^l x^2 dx = \frac{1}{8} \frac{wl^4}{EI}$$

which agrees with (7), Art. 79.

(b) *Irregularly Loaded Cantilever.*—For any irregular loading of a cantilever the same method can be applied after the bending-moment diagram ABFEDA has been drawn (Fig. 119). The deflection of the free end is given by  $\frac{A \cdot \bar{x}}{EI}$  as before, the scales being suitably chosen.

The method in such a case is a purely graphical one, consisting in drawing the bending-moment diagram to scale, measuring A and finding  $\bar{x}$  by any of the various graphical methods, or finding the product  $A\bar{x}$  by a derived area, as in Art. 68; the derived area corresponding to the pole B would represent the area under a curve  $M \cdot x$  with origin at B.

If the irregular loading consists of a number of concentrated loads, the whole area A may be looked upon as the sum of the areas of a number of triangles, and the product  $A \cdot \bar{x}$  as the sum of the products of the areas of the several triangles and the distances of their centroids from the free end.

*Propped Cantilever. Irregular Load.*—If the cantilever is propped at the end, let P be the upward reaction of the prop at B (Fig. 119). The bending-moment diagram for the irregular loading is ABFED, and that for the prop is the triangle ABC, the ordinates being of opposite sign. The moments of these two areas about B are together zero, for the quantity  $\left(x \frac{dy}{dx} - y\right)$  between limits 0 and  $l$  is zero, every term being zero, hence—

$$A \cdot \bar{x} = \frac{1}{2} \cdot Pl \times l \times \frac{2}{3}$$

$$P = \frac{3A \cdot \bar{x}}{l^2}$$

a general formula applicable to regular or irregular loads, the latter problem being worked graphically.

The resultant bending-moment diagram is shown shaded in Fig. 119, E giving the point of inflection. The parts DCE and EFB are of opposite sign.

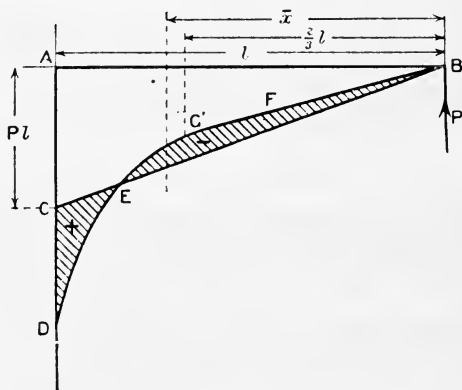

FIG. 119.

The deflection of any point X between A and B may be found by taking the moment about X of so much of this diagram as lies between verticals through X and A, taking account of the signs of the areas. Since the areas reckoned from A represent the slopes, the slope is zero, and the deflection a maximum at some point to the right of E where the area to the right of E is equal to DCE.

If the cantilever is propped somewhere between A and B the above formula holds good, provided the area A and the length  $\bar{x}$  refer to the portion of the diagram ABFED between A and the prop,  $\bar{x}$  being measured from the prop, and  $l$  refers to the distance of the prop from A.

(c) *Beam supported at two Points on the same Level.*—Taking the origin at one end A (Figs. 116 and 120)—

$$\left(x \frac{dy}{dx} - y\right)_0^l = l \cdot i_B = \frac{1}{EI} \int_0^l Mx dx = \frac{A\bar{x}}{EI}$$

where A is the area of the bending-moment diagram, and  $\bar{x}$  is the distance of its centroid from A, or  $A \cdot \bar{x}$  represents the moment of the area about the origin A, hence—

$$i_B = \frac{A \cdot \bar{x}}{EI \cdot l} \dots \dots \dots (6)$$

and similarly from the moment about B—

$$i_A = - \frac{A(l - \bar{x})}{EI \cdot l} \dots \dots \dots (7)$$

and is of opposite sign to  $i_B$ . With the convention of signs given in Art. 77, A is negative for a beam carrying downward loads which produce convexity downwards; hence  $i_A$  is positive and  $i_B$  is negative.

Thus (in magnitude) the slopes at the supports are proportional to the area of the bending-moment diagram between them, and the ratio of one to the other is inversely proportional to the ratio of the distances of the supports from the centroid of that area—just the same kind of relation, it may be noted, that the reactions at the supports have to the total load.

If the area of the bending-moment diagram from A to a point X, distant  $x$  to the right of A, be  $A_x$ , which is negative with convexity downwards, and the slope at  $x$  is  $i_x$ —

$$i_x = i_A + \frac{1}{EI} \int_0^x M dx \text{ or } i_A + \frac{A_x}{EI} \dots \dots \dots (8)$$

which is zero at the section where maximum deflection occurs,  $A_x$  being negative.

Again, since  $\left(x \frac{dy}{dx} - y\right)_0^x = xi_x - y_x = \frac{1}{EI} \int_0^x Mx dx$

$$y_x = x \cdot i_x - \frac{1}{EI} \int_0^x Mx dx \dots \dots \dots (8a)$$

and substituting for  $i_x$  from (8)—

$$\begin{aligned} y_x &= x \cdot i_A + \frac{x}{EI} \int_0^x M dx - \frac{1}{EI} \int_0^x M x dx \\ &= x i_A + \frac{x A_x}{EI} - \frac{1}{EI} (\text{moment of } A_x \text{ about A}) \quad (9) \end{aligned}$$

or the deflection at X is—

$$y_x = (x \times \text{slope at A}) + (\text{moment of } A_x \text{ about X}) \frac{1}{EI} \quad (10)$$

which gives the deflection anywhere along the beam, the second term being negative. And from (8a) we may write—

$$y_x = (x \times \text{slope at X}) - (\text{moment of } A_x \text{ about A}) \frac{1}{EI} \quad (11)$$

remembering that  $A_x$  is a negative quantity.

Probably the form (10) is more convenient than (11),  $i_A$  being a constant. As indicated by (8), the slope at X will be negative if X is beyond the point of maximum deflection. Note that the second term in (10) is negative, and represents the vertical displacement of the beam at X from the tangent at A, and the second term in (11) represents the vertical displacement of the beam at A from the tangent at X. In the case of convexity upwards the signs of these second terms would be changed. The reader should illustrate the geometrical meaning of the various terms on sketches of beams under various conditions.

*Overhanging Ends.*—The deflection at any point on an overhanging end, such as in Figs. 67, 68, 72, or 73, may be determined as for a cantilever, provided the deflection due to the slope at the support be added (algebraically). For points between the supports of an overhanging beam the above relations hold, provided that the signs of the areas and moments of areas, etc., be taken into account. For irregular loading these processes may be carried out graphically, and the moments of areas ( $A \cdot \bar{x}$ ) may be found by a "derived area," as in Art. 68, without finding the centres of gravity of the areas.

When the above expressions for slopes and deflections, which are applicable to any kind of loading, are written down symbolically in terms of dimensions of the bending-moment diagram, they give algebraic expressions, such as have already been obtained in other ways for various cases of loading, e.g. the deflection and slope anywhere for a beam carrying a single concentrated load may be found in this way as an alternative to the methods in Art. 80.

*Non-central Load.*—From Fig. 116 and (7) above, dividing the moment of the area of the bending-moment diagram about B into two parts—

$$\begin{aligned} i_A &= \frac{1}{EI(a+b)} \left\{ \left( \frac{1}{2} \cdot b \cdot \frac{Wab}{a+b} \cdot \frac{2}{3}b \right) + \frac{1}{2}a \frac{Wab}{a+b} \cdot \left( b + \frac{a}{3} \right) \right\} \\ &= \frac{Wab(a+2b)}{6EI(a+b)} \dots \dots \dots (12) \end{aligned}$$

and from (8) within the range A to C—

$$i_x = i_A - \frac{I}{EI}(\text{area PAX}) = i_A - \frac{I}{EI} \left( \frac{Wbx}{a+b} \cdot \frac{x}{2} \right) \\ = \frac{Wb}{EI(a+b)} \left( \frac{a^2 + 2ab}{6} - \frac{x^2}{2} \right) \dots \dots \dots (13)$$

which agrees with (2a), Art. 80.

For  $i_x = 0$   $x^2 = \frac{1}{3}(a^2 + 2ab)$

Also from (10), within the range A to C—

$$y = i_A \cdot x - \frac{Wbx}{EI(a+b)} \cdot \frac{x}{2} \cdot \frac{x}{3} = \frac{Wbx}{EI(a+b)} \left( \frac{a^2 + 2ab - x^2}{6} \right) \dots \dots (14)$$

which agrees with (7), Art. 80. And when  $x = a$ —

$$y_c = \frac{Wa^2b^2}{3EI(a+b)} \dots \dots \dots (15)$$

*Several Loads.*—If there are several vertical loads  $W_1, W_2, W_3,$  and

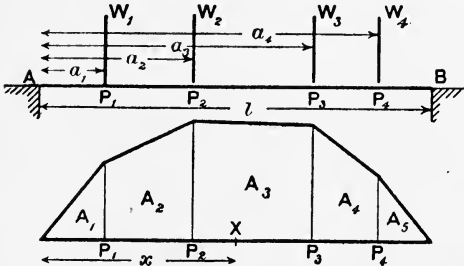

$W_4$  at  $P_1, P_2, P_3,$  and  $P_4$  (Fig. 120), distant  $a_1, a_2, a_3,$  and  $a_4$  from A, the bending-moment diagram may be drawn as in Art. 58, or calculated as in Art. 56. Let the bending moments at  $P_1, P_2, P_3,$  etc., be  $M_1, M_2, M_3,$  etc., respectively. Let the total area of the bending-moment diagram be  $A$ , and let it be divided by verticals through  $P_1, P_2,$

$P_3,$  and  $P_4$  (Fig. 120), into five parts,  $A_1, A_2, A_3, A_4,$  and  $A_5$ , as shown, so that—

$$A_1 = \frac{a_1 M_1}{2} \quad A_2 = \frac{M_1 + M_2}{2} (a_2 - a_1) \quad A_3 = \frac{M_2 + M_3}{2} (a_3 - a_2)$$

and so on, all the areas being negative for downward loads.

Then 
$$i_A = - \frac{I}{EI} \frac{A(l - \bar{x})}{l}$$

where  $\bar{x}$  is the distance of the centroid of the area  $A$  from the origin A, and  $l - \bar{x}$  is its distance from B.

The quantity  $A(l - \bar{x})$ , or the moment of the area  $A$  about B, may be found by the sum of the moments of the triangular areas of the bending-moment diagrams, which might be drawn for the several weights separately, *i.e.* the quantity  $i_A$  is the sum of four such terms as (12) above.

The slopes at  $P_1, P_2, P_3$ , etc., are then—

$$i_1 = i_A + \frac{A_1}{EI} \quad i_2 = i_A + \frac{A_1 + A_2}{EI} \quad i_3 = i_A + \frac{A_1 + A_2 + A_3}{EI}$$

and so on, the second term in each case being negative.

The segment in which the slope passes through zero is easily found from the slope, or total area from point A to successive loads. If the zero slope occurs between, say,  $P_2$  and  $P_3$ , the slopes at  $P_2$  and  $P_3$  are of opposite sign—

$$\begin{aligned} - (A_1 + A_2) \text{ is less than } - \frac{A(l - \bar{x})}{l} \\ - (A_1 + A_2 + A_3) \text{ is greater than } - \frac{A(l - \bar{x})}{l} \end{aligned}$$

If the zero slope is at X, distant  $x$  from A, the bending moment there is  $M_2 + \frac{x - a_2}{a_3 - a_2} (M_3 - M_2)$ , and the slope being zero, the area from point A to the point X of zero slope is equal to  $A \cdot \frac{l - \bar{x}}{l}$ , or—

$$A_1 + A_2 + \left( M_2 + \frac{x - a_2}{a_3 - a_2} \cdot \frac{M_3 - M_2}{2} \right) (x - a_2) = A \cdot \frac{l - \bar{x}}{l}$$

from which quadratic equation  $x$  may be found.

The magnitude of the maximum deflection is then easily found from (11) above, viz.—

$-\frac{I}{EI}$  (moment about point A of the bending-moment diagram over AX) an expression which may conveniently be written down after dividing the area over AX into triangles, say, by diagonals from  $P_2$ . The deflection elsewhere may be found from equation (10). With numerical data this method will appear much shorter than in the above symbolic form. Other purely graphical methods for the same problem are given in the next article.

*Other Cases.*—Beams carrying uniformly distributed loads over part of the span might conveniently be dealt with by these methods, the summation of moments of the bending-moment diagram area being split up into separate parts with proper limits of integration at sudden changes or discontinuities in the rate of loading.

EXAMPLE 1.—The example at the end of Art. 80 may be solved from the bending-moment diagram as follows:—

Let the bending-moment diagram be drawn by the funicular polygon (see Art. 58), or by calculation (see Art. 57). It is shown in Fig. 117, AEDB being the diagram for the two loads on the unsupported span AB. Then from (7)—

$$i_A = - \frac{I}{EI} \text{ (moment of area AEDB about B) } \div AB$$

Divide the (negative) area AEDB into four triangles by joining DF for

convenience in calculating the above moment. Using ton and feet units—

$$i_A = \frac{1}{20EI} \left[ \left( \frac{25.4 \times 4}{2} \cdot \frac{2}{3} \cdot 4 \right) + \left\{ \frac{25.4 \times 11}{2} \times \left( 4 + \frac{11}{3} \right) \right\} \right. \\ \left. + \left\{ \left( \frac{18.25 \times 11}{2} \right) \times \left( 4 + \frac{22}{3} \right) \right\} + \left\{ \left( \frac{18.25 \times 5}{2} \right) \left( 15 + \frac{5}{3} \right) \right\} \right] \\ i_A = \frac{155.2}{EI}$$

And from (10), dividing EHCF by a diagonal FH—

$$j_C = \frac{155.2}{EI} \times 9 - \frac{1}{EI} \left[ \left( \frac{20.85 \times 4}{2} \cdot \frac{4}{3} \right) + \left( \frac{18.25 \times 4}{2} \cdot \frac{8}{3} \right) \right. \\ \left. + \left\{ \left( \frac{18.25 \times 5}{2} \right) \left( 4 + \frac{5}{3} \right) \right\} \right] \\ j_C = \frac{1397 - 411.5}{EI} = \frac{985.5}{EI} \text{ (downward)}$$

For an upward load  $R_C$  at C, by (15)—

$$j_C = \frac{R_C \times 81 \times 121}{3EI \times 20} = \frac{163.35 R_C}{EI} \text{ (upward)}$$

Equating this to the downward deflection at C—

$$R_C = \frac{985.5}{163.35} = 6.03 \text{ tons} \\ R_A = \frac{(7 \times 4) + (15 \times 3) - (6.03 \times 11)}{20} = 0.334 \text{ ton} \\ R_B = 10 - 0.334 - 6.03 = 6.636 \text{ tons}$$

The above methods might now be applied to the resultant bending-moment diagram, shown shaded in Fig. 117, to determine the deflection anywhere between A and C, or between C and B, and the position of the maximum deflection, etc.

EXAMPLE 2.—Find the deflection of the free ends of the beam in Fig. 68. From (6) and (7) above, slopes downward towards the right—

$$i_A = -i_B = -\frac{1}{EI} \cdot \frac{l_2}{2} \cdot \frac{1}{l_2} \int_0^{l_2} \left\{ \frac{wl_1^2}{2} - \frac{w}{2}(l_2x - x^2) \right\} dx$$

$$\text{or,} \quad -\frac{1}{2EI} \left( \frac{wl_1^2 l_2}{2} - \frac{wl_2^2}{8} \times \frac{2}{3} \times l_2 \right) = -\frac{wl_2}{24EI} (6l_1^2 - l_2^2)$$

which is negative if  $l_2$  is less than  $l_1 \sqrt{6}$

Downward deflection at the free end is—

$$-i_A l_1 + \frac{wl_1^4}{8EI} = \frac{wl_1}{24EI} (6l_1^2 l_2 - l_2^3 + 3l_1^3)$$

Upward deflection at the centre consists of—

(upward deflection due to end loads) — (downward deflection due to load between supports)

which, using (11) for the first term, is—

$$\frac{1}{EI} \left( 0 + \frac{wl_1^2}{2} \cdot \frac{l_2}{2} \cdot \frac{l_2}{4} \right) - \frac{5}{384} \frac{wl^4}{EI} = \frac{wl_2^2}{16EI} (l_1^2 - \frac{5}{24} l_2^2)$$

which is positive if  $l_2$  is less than  $\sqrt{4 \cdot 8} l_1$ .

EXAMPLE 3.—Find the deflection at B and midway between A and C in Ex. 2 of Art. 59 (see Fig. 72).

Taking the origin at A,  $R_A$  being 10 tons, by (6), downwards towards B—

$$i_c = \frac{1}{16EI} \int_0^{16} \left( 10x + \frac{x^2}{2} \right) x dx = \frac{1}{16EI} \left( \frac{10}{3} x^3 + \frac{x^4}{8} \right)_0^{16} = \frac{21,845 \cdot 3}{16EI}$$

E being in tons per square foot, and I in (feet)<sup>4</sup>—

$$\begin{aligned} \text{Deflection at B} &= \left( 8 \times \frac{21,845 \cdot 3}{16EI} \right) + \frac{32 \times 8 \times 8 \times 8}{3EI} + \frac{8 \times 8 \times 8 \times 8}{8EI} \\ &= \frac{16,896}{EI} \text{ feet} \end{aligned}$$

(If E and I are in inch units, deflection at B =  $1728 \times \frac{16,896}{EI}$  inches.)

Taking an origin midway between A and C and  $x$  positive towards C—

$$M = 10(8 + x) + \frac{1}{2}(8 + x)^2 = \frac{x^2}{2} + 18x + 112 \text{ tons-feet}$$

and using (4a) over the range from the origin to C, the deflection upward at the origin is—

$$\begin{aligned} 8 \times \frac{21,845 \cdot 3}{16EI} - \frac{1}{EI} \int_0^8 \left( \frac{x^3}{2} + 18x^2 + 112x \right) dx \\ = \frac{1}{EI} (10,922 - 7168) = \frac{3754}{EI} \text{ feet} \end{aligned}$$

or,  $1728 \times \frac{3754}{EI}$  inches if E is in tons per square inch and I in (inches)<sup>4</sup>.

## 82. Other Graphical Methods.

*First Method.*—The five equations of Art. 77 immediately suggest a possible graphical method of finding deflections, slopes, etc., from the curve showing the distribution of load on the beam. If the five quantities  $w$ ,  $F$ ,  $M$ ,  $i$ , and  $y$  (see Art. 77) be plotted successively on the length of the beam as a base-line, each curve will represent the integral of the one preceding it, *i.e.* the difference between any two ordinates of any curve will be proportional to the area included between the two corresponding ordinates of the preceding curve.

Hence, if the first be given, the others can be deduced by measuring areas, *i.e.* by graphical integration. Five such curves for a beam simply supported at each end are shown in Fig. 121. At the ends

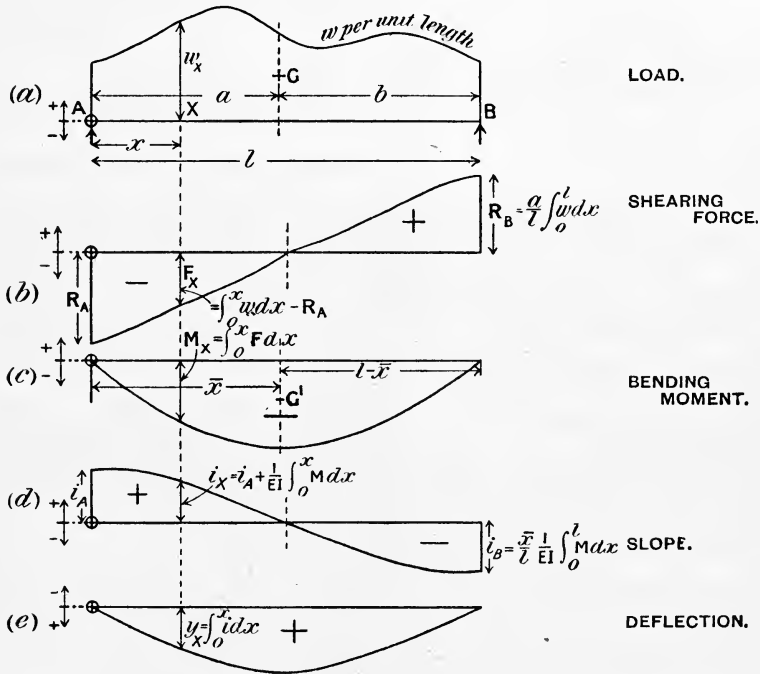

FIG. 121.

the shearing forces and slopes are not zero, but the methods of finding their values have already been explained, and are shown in Fig. 121,  $G$  and  $G'$  being the centroids of the loading- and bending-moment diagrams respectively. The reader should study the exact analogies between the various curves. In carrying into practice this graphical method the various scales are of primary importance; the calculation of these is indicated below.

In the case of a cantilever, the  $F$  and  $M$  curves corresponding to (b) and (c), Fig. 121, must start from zero at the free end (unless there is a concentrated end load), and the  $i$  and  $y$  curves corresponding to (d) and (e), Fig. 121, must start from zero at the fixed end.

*Scales for Fig. 121.*—Linear scale along the span,  $q$  inches to 1 inch;  $E$  in pounds per square inch;  $I$  in (inches)<sup>4</sup>.

(a) Ordinates,  $p$  lbs. per inch run = 1 inch.

Therefore 1 square inch area represents  $p \cdot q$  lb. load.



- (b) Ordinates,  $n$  square inches from (a) = 1 inch =  $n \cdot p \cdot q$  lbs.  
Areas 1 square inch represent  $n \cdot p \cdot q^2$  lb.-inches.
- (c) Ordinates,  $m$  square inches from (b) = 1 inch =  $mnpq^2$  lb.-inches.  
Areas 1 square inch represent  $mnpq^3$  lb.-inches<sup>2</sup>
- (d) Ordinates,  $n'$  square inches from (c) = 1 inch =  $\frac{n'mnpq^3}{EI}$  radians.  
Areas 1 square inch represent  $\frac{n'mnpq^4}{EI}$  inches.
- (e) Ordinates,  $m'$  square inches from (d) = 1 inch =  $\frac{m'n'mnpq^4}{EI}$  inches.

If instead of  $p$  lbs. per inch run to 1 inch the force scale is  $p$  lbs. to 1 inch, the deflection scale would be  $\frac{m'n'mnpq^3}{EI}$  inches to 1 inch.

*Second Method.*—This is probably the best method for irregular types of loading. The equations—

$$\frac{d^2y}{dx^2} = \frac{1}{EI} \cdot M \quad \text{and} \quad \frac{d^2M}{dx^2} = w$$

or the diagrams in Fig. 121 show that the same kind of relation exists between bending moment ( $M$ ) and deflection ( $y$ ) as between the load per unit of span ( $w$ ) and the bending moment. Hence, the curve showing  $y$  on the span as a base-line can be derived from the bending-moment diagram in the same way that the bending-moment diagram is derived from the diagram of loading, viz. by the funicular polygon (see Art. 58). If the bending-moment diagram be treated as a diagram of loading, the funicular polygon derived from it will give the polygon, the sides of which the curve of deflection touches internally, and which approximates to the curve of deflection with any desired degree of nearness.

With a distributed load it was necessary (Art. 58) to divide the loading diagram into parts (preferably vertical strips), and take each part of the load as acting separately at the centroid of these parts. Similarly the bending-moment diagram, whether derived from a distributed load or from concentrated loads, must be divided into parts (see Fig. 122), and each part of the area treated as a force at its centre of gravity or centroid. A second pole  $O'$  is chosen, and the distances  $ab, bc, cd, de$ , etc., set off proportional to the areas of bending-moment diagram, having their centroids on the lines  $AB, BC, CD, DE$ , etc. The second funicular polygon, with sides parallel to lines radiating from  $O'$ , gives approximately the curve of deflection; the true curve is that inscribed within this polygon, for the tangents to the deflection curve at any two cross-sections must intersect vertically below the centroid of that part of the bending-moment diagram lying between those two sections.

To show the form of the beam when deflected the deflection curve must be drawn on a base parallel to the beam, *i.e.* horizontal. This can be done by drawing the second vector polygon again with a pole

on the same level as  $r'$ , and drawing another funicular polygon corresponding to it, or by setting off the ordinates of the second funicular polygon from a horizontal base-line.

This method is applicable to other cases than that of the simply supported beam here illustrated, provided the bending-moment diagram has been determined. When different parts of a beam have opposite curvature, *i.e.* when the curvature changes sign, *e.g.* in a overhanging or in a built-in beam (see Chap. VII.), the proper sign must be attached to

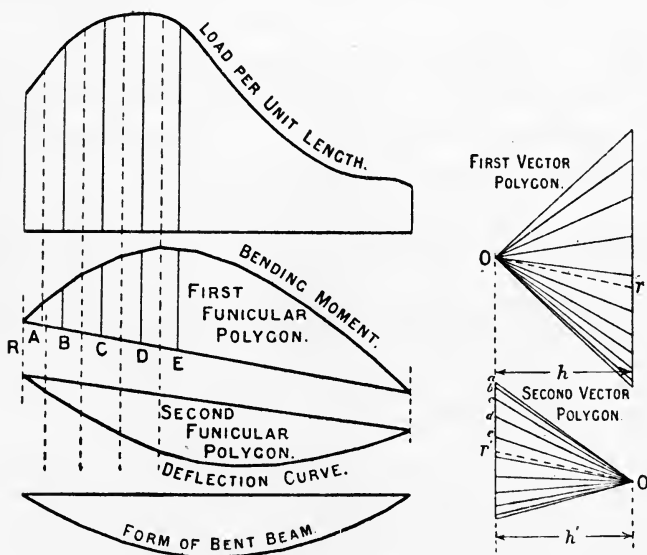

FIG. 122.

the vertical vectors in the vector polygon. If bending-moment diagram areas of one kind are represented by downward vectors, those of opposite kind (or sign) must be represented by upward vectors.

*Scales.*—If the linear horizontal scale is  $q$  inches to 1 inch and the force scale is  $p$  lbs. to 1 inch, the horizontal polar distance of the first vector polygon being  $h$  inches, the scale of the bending-moment diagram ordinates is  $p \cdot q \cdot h$  lb.-inches to 1 inch, as in Art. 58. One square inch area of the bending-moment diagram represents  $p \cdot q^2 \cdot h$  lb.-inches<sup>2</sup>; and if the (horizontal) polar distance of the second vector polygon is  $h'$  inches, and the vector scale used for it is  $m$  square inches of bending-moment diagram to 1 inch, the deflection curve represents  $EI \cdot y$  on a scale  $m \cdot p \cdot q^3 \cdot h \cdot h'$  lb.-inches<sup>3</sup> to 1 inch, and therefore represents  $y$  on a scale—

$$\frac{m \cdot p \cdot q^3 \cdot h \cdot h'}{EI} \text{ inches to 1 inch}$$

$E$  being in pounds per square inch, and  $I$  in (inches)<sup>4</sup>.

If instead of a force  $p$  lbs. to 1 inch a scale of  $p$  lbs. *per inch run* to 1 inch be used on a diagram of continuous loading, as shown in Fig. 122, the final scale would be  $\frac{mpq^2hh'}{EI}$  inches to 1 inch. If the forces are in tons,  $E$  should be expressed in tons, and the other modifications in the above are obvious.

**83. Beams of Variable Cross-Section.**—The slopes and deflections so far investigated have been those for beams of constant section, so that the relation (3) of Art. 77—

$$i = \int \frac{M}{EI} dx \text{ has become } \frac{1}{EI} \int M dx$$

If, however,  $I$  is not constant, but  $E$  is constant, this becomes—

$$i = \frac{1}{E} \int \frac{M}{I} dx$$

and the equation (1), Art. 81, becomes—

$$i_2 - i_1 = \frac{1}{E} \int_{x_1}^{x_2} \left( \frac{M}{I} \right) dx$$

and the equation (3), Art. 81, becomes—

$$\left( x \frac{dy}{dx} - y \right)_{x=x_1}^{x=x_2} = \frac{1}{E} \int_{x_1}^{x_2} \frac{Mx}{I} dx$$

The methods of finding the slopes and deflections employed in Arts. 78, 79, 81, and 82 may therefore be applied to beams of variable section, provided that the quantity  $\frac{M}{I}$  is used instead of  $M$  throughout.

Where  $I$  and  $M$  are both expressed as simple algebraic functions of  $x$  (distance along the beam), analytical methods can usually be employed (see Ex. 1 below), but when either or both vary in an irregular manner, the graphical methods should be used. Thus equation (3) of Art. 81 may be written—

$$\left( x \frac{dy}{dx} - y \right)_{x_1}^{x_2} = \frac{A\bar{x}}{E}$$

where  $A$  or  $\int_{x_1}^{x_2} \frac{M}{I} dx$  = area under the curve  $\frac{M}{I}$  and  $\bar{x}$  is the distance

of its centroid from the origin. The moment  $A\bar{x}$  may of course be found conveniently by a derived area (see Art. 68). When the quantity  $I$  varies suddenly at some section of the beam, but is a simply expressed quantity over two or more ranges, neglecting the effects of a discontinuity in the cross-section, ordinary integration may be employed if the integrals are split up into ranges with suitable

limits (see Ex. 2 below). The solution of problems on propped beams of all kinds by equating the upward deflection at the prop caused by the reaction of the prop to the downward deflection of an unpropped beam caused by the load, is still valid, the deflections being calculated for the varying section as above. For example, the equation giving the load carried by a prop at the end of a cantilever, with any loading, as in Fig. 119, may be stated as follows. If  $M$  is the bending moment in terms of the distance from the free end B—

$$\int_0^l \frac{M}{I} x dx = \int_0^l \frac{Px}{I} x dx = P \int_0^l \frac{x^2}{I} dx$$

and

$$P = \int_0^l \frac{Mx}{I} dx \div \int_0^l \frac{x^2}{I} dx$$

For a graphical solution, let  $A$  be the area enclosed by the curve  $\frac{M}{I}$ , and  $\bar{x}$  the distance of its centroid from B. Assume any load  $p$  on the prop, and let  $P = ap$ . Draw the bending-moment diagram (a straight line) for the end load  $p$ ; divide each ordinate ( $p \cdot x$ ) by  $I$ , giving a curve  $\frac{p \cdot x}{I}$ . Let  $A'$  be the area enclosed by this curve, and  $\bar{x}'$  the distance of its centroid from B. Then the above equation in graphical form becomes—

$$A \cdot \bar{x} = a \cdot A' \cdot \bar{x}' \\ a = A\bar{x} \div A'\bar{x}' \text{ and } P = ap$$

The moments  $A \cdot \bar{x}$  and  $A' \cdot \bar{x}'$  may be most conveniently found graphically by the derived area method of Art. 68, with B as pole; the bases ( $l$ ) being the same for each diagram, the equation  $A \cdot \bar{x} = aA'\bar{x}'$  becomes—

$$\text{first derived area of } A = a(\text{first derived area of } A')$$

The scales are not important,  $a$  being a mere ratio; it is only necessary to set off the ordinate  $pl$  in the bending-moment diagram for the assumed reaction  $p$ , on the same scale as the bending-moment diagram for the loading. A more general application of these methods to other cases will be found in Arts. 88 and 91.

EXAMPLE 1.—A cantilever of circular section tapers in diameter uniformly with the length from the fixed end to the free end, where the diameter is half that at the fixed end. Find the slope and deflection of the free end due to a weight  $W$  hung there.

Let  $D$  be the diameter at the fixed end at O, which is taken as origin (Fig. 113). Then diameter at a distance  $x$  from O is—

$$D\left(1 - \frac{x}{2l}\right) \text{ or } \frac{D}{2l}(2l - x)$$

At O about the neutral axis,  $I_0 = \frac{\pi}{64} D^4$  (see Art. 66); hence at a distance  $x$  from O—

$$I = \frac{\pi}{64} D^4 \left(1 - \frac{x}{2l}\right) \text{ or } \frac{I_0}{16l} (2l - x)^4$$

and  $M = W(l - x)$  (see Fig. 59).

$$\text{Then } \frac{dy}{dx} \text{ or } i = \frac{1}{E} \int_0^x \frac{M}{I} dx = \frac{16Wl^4}{EI_0} \int_0^x \frac{l - x}{(2l - x)^4} dx$$

or in partial fractions—

$$\begin{aligned} i &= \frac{16Wl^4}{EI_0} \int_0^x \left\{ \frac{-l}{(2l - x)^4} + \frac{1}{(2l - x)^3} \right\} dx \\ &= \frac{16Wl^4}{EI_0} \left( -\frac{1}{3} \cdot \frac{l}{(2l - x)^3} + \frac{1}{2} \frac{1}{(2l - x)^2} - \frac{1}{12l^2} \right) \end{aligned}$$

the constant term  $-\frac{1}{12l^2}$  being such that  $i = 0$  for  $x = 0$ .

Then, for  $x = l$ —

$$i_A = \frac{4}{3} \cdot \frac{Wl^2}{EI_0}$$

Also

$$y = \int_0^x i dx = \frac{16Wl^4}{EI_0} \left( -\frac{1}{6} \frac{l}{(2l - x)^2} + \frac{1}{2(2l - x)} - \frac{x}{12l^2} - \frac{5}{24l} \right)$$

$$\text{and for } x = l \quad y_A = \frac{2}{3} \cdot \frac{Wl^3}{EI_0}$$

If the deflection only were required, it might be obtained by a single integration by modifying (3), Art. 81, taking the origin at the free end A, Fig. 113—

$$\begin{aligned} \left( x \frac{dy}{dx} - y \right)_0^l &= y_A = \frac{1}{E} \int_0^l \frac{Mx}{I} dx \\ y_A &= \frac{16Wl^4}{EI_0} \int_0^l \frac{x^2}{(l+x)^4} dx = \frac{16Wl^4}{EI_0} \int_0^l \left\{ \frac{l^2}{(l+x)^4} - \frac{2l}{(l+x)^3} + \frac{1}{(l+x)^2} \right\} dx \\ &= \frac{16Wl^4}{EI_0} \left\{ -\frac{1}{3} \frac{l^2}{(l+x)^3} + \frac{l}{(l+x)^2} - \frac{1}{(l+x)} \right\}_0^l = \frac{2}{3} \frac{Wl^3}{EI_0} \text{ (as before)} \end{aligned}$$

EXAMPLE 2.—A cantilever of circular section is of constant diameter from the fixed end to the middle, and of half that diameter from the middle to the free end. Estimate the deflection at the free end due to a weight  $W$  there.

If  $I_0 =$  moment of inertia of the thick end (fixed)  
 $\frac{1}{16}I_0 =$  " " " " thin " (free).

As in Art. 79, taking the origin at the fixed end O (Fig. 113), from O to C (the middle point)—

$$\begin{aligned} \frac{d^2y}{dx^2} &= \frac{W}{EI_0}(l - x) \\ \text{i or } \frac{dy}{dx} &= \frac{W}{EI_0}(lx - \frac{1}{2}x^2) + o \\ \text{and at } x = \frac{l}{2} \quad i_c &= \frac{3}{8} \frac{Wl^2}{EI_0} \\ y &= \int idx = \frac{W}{2EI_0}(lx^2 - \frac{1}{3}x^3) + o \\ \text{and at } x = \frac{l}{2} \quad y_c &= \frac{5Wl^3}{48EI_0} \end{aligned}$$

From C to A (free end)—

$$\begin{aligned} i &= \frac{16W}{EI_0}(lx - \frac{1}{2}x^2) + A \\ \text{at } x = \frac{l}{2} \quad i &= \frac{3}{8} \frac{Wl^2}{EI_0} \text{ (above) } \quad \text{hence } A = -\frac{45}{8} \frac{Wl^2}{EI_0} \\ y &= \int idx = \frac{W}{EI_0} \left\{ 8(lx^2 - \frac{1}{3}x^3) - \frac{45}{8}l^2x + B \right\} \\ \text{at } x = \frac{l}{2} \quad y &= \frac{5}{48} \frac{Wl^3}{EI_0} \text{ (above) } \quad \text{hence } B = \frac{5}{4}l^3 \\ y &= \frac{W}{EI_0} \left\{ 8(lx^2 - \frac{1}{3}x^3) - \frac{45}{8}l^2x + \frac{5}{4}l^3 \right\} \\ \text{and at } x = l \quad y_A &= \frac{23}{24} \frac{Wl^3}{EI_0} \end{aligned}$$

To find the deflection only the method of Art. 81 might be used, taking the origin at A, the free end (Fig. 113). Then  $M = Wx$ , and splitting the integration into two ranges, over which  $I$  is  $I_0$  and  $\frac{1}{16}I_0$ —

$$\begin{aligned} y &= \frac{1}{E} \int_0^l \frac{Mx}{I} dx = \frac{1}{EI_0} \int_{\frac{l}{2}}^l Wx^2 dx + \frac{16}{EI_0} \int_0^{\frac{l}{2}} Wx^2 dx \\ &= \frac{W}{EI_0} \left[ \frac{1}{3} \left\{ l^3 - \left(\frac{l}{2}\right)^3 \right\} + \frac{16}{3} \left(\frac{l}{2}\right)^3 \right] = \frac{23}{24} \frac{Wl^3}{EI_0} \end{aligned}$$

*Deflection of Rectangular Beams of Uniform Strength.*—The condition of uniform bending strength (Art. 70) is  $\frac{M}{Z} = f = \text{constant}$ , where  $Z$  (the modulus of section) =  $I \div \frac{d}{2}$  for a rectangular beam of depth  $d$ ; hence—

$$\frac{d^2y}{dx^2} = \frac{M}{EI} = \frac{1}{E} \cdot \frac{2f}{d} \dots \dots \dots (1)$$

*Varying Breadth.*—If  $d$  is constant, evidently the curvature  $\frac{d^2y}{dx^2}$  is constant, and the beam bends to a circular arc, and the deflections might be found by the method of Art. 76.

Or by direct integration, for the cantilever of length  $l$  and any loading, taking the origin at the wall, the maximum slope (at the free end) is—

$$\frac{2fl}{Ed} \text{ or } \frac{M_0 l}{EI_0} \dots \dots \dots (2)$$

where  $M_0$  and  $I_0$  refer to, say, the fixed end, where  $M$  and  $I$  reach their greatest values, and the maximum deflection is—

$$\frac{fl^2}{ED} \text{ or } \frac{M_0 l^2}{2EI_0} \dots \dots \dots (3)$$

The case of a beam simply supported at its ends, and loaded symmetrically on either side of the middle of the span, can be deduced from this by taking the origin at mid-span and writing  $\frac{l}{2}$  for  $l$  where  $M_0$  and  $I_0$  refer to the middle section.

*Varying Depth.*—If the breadth is constant and the depth varies—

$$f = \frac{M}{Z} = \frac{M_0}{Z_0} \text{ and } \frac{Z_0}{Z} = \frac{M_0}{M}$$

hence 
$$\frac{D^2}{d^2} = \frac{M_0}{M} \text{ or } \frac{1}{d} = \frac{1}{D} \sqrt{\frac{M_0}{M}}$$

where 
$$Z_0 = \frac{1}{6} b D^2 \text{ and } Z = \frac{1}{6} b d^2$$

$b$  being the constant breadth,  $d$  the variable depth, and  $D$  the maximum value of  $d$  corresponding to  $Z_0$  and  $M_0$ . Hence (1) becomes—

$$\frac{d^2y}{dx^2} = \frac{2f}{ED} \sqrt{\frac{M_0}{M}} \dots \dots \dots (4)$$

and 
$$i = \frac{2f \sqrt{M_0}}{ED} \int \frac{dx}{\sqrt{M}} \dots \dots \dots (5)$$

a suitable constant of integration being added in particular cases, and the integral depending on what function  $M$  is of  $x$ . Then for the deflection  $y = \int i dx$ .

For example, a cantilever with end load  $W$  (Fig. 113), with origin  $O$ ,  $M = W(l - x) = M_0 \frac{l - x}{l}$ , the maximum values (at the free end) of the slope and deflection are—

$$i_A = \frac{2Wl^2}{EI_0} \text{ or } \frac{2M_0 l}{EI_0} \text{ or } \frac{4fl}{ED} \dots \dots \dots (6)$$

$$y_A = \frac{2}{3} \frac{Wl^3}{EI_0} \text{ or } \frac{2}{3} \frac{M_0 l^2}{EI_0} \text{ or } \frac{4}{3} \frac{fl^2}{EI_0} \dots \dots \dots (7)$$

With a uniformly distributed load  $wl$  (Fig. 115),  $M = \frac{w}{2}(l-x)^2$ ;  $i_A$  is infinite, that is, the tangent line is vertical, and the deflection—

$$y_A = \frac{wl^4}{2EI_0} \text{ or } \frac{M_0 l^2}{EI_0} \text{ or } \frac{2fl}{ED}$$

For the simply supported beam with central load  $W$  (Fig. 111), writing  $\frac{l}{2}$  for  $l$  and  $\frac{W}{2}$  for  $W$  in (6) and (7)—

$$i_B = i_A = \frac{Wl^2}{4EI} \text{ or } \frac{M_0 l}{EI} \text{ or } \frac{2fl}{ED} \dots (8)$$

$$y_C = \frac{Wl^3}{24EI} \text{ or } \frac{M_0 l^2}{6EI_0} \text{ or } \frac{fl^2}{3ED} \dots (9)$$

and with a uniformly distributed load  $wl$  (Fig. 112),

$$M = \frac{w}{2} \left( \frac{l^2}{4} - x^2 \right) = M_0 \frac{l^2}{l^2 - 4x^2},$$

$$i_B = i_A = \frac{\pi}{32} \frac{wl^3}{EI_0} \text{ or } \frac{\pi}{4} \cdot \frac{M_0 l}{EI} \text{ or } \frac{\pi}{2} \frac{fl}{ED}$$

$$y_C = \frac{1}{32} \left( \frac{\pi}{2} - 1 \right) \frac{wl^4}{EI_0} \text{ or } \frac{1}{4} \left( \frac{\pi}{2} - 1 \right) \frac{M_0 l^2}{EI_0} \text{ or } \frac{1}{2} \left( \frac{\pi}{2} - 1 \right) \frac{fl^2}{ED}$$

The verification of the above values by integration are left as exercises for the reader.

*Deflection of a Carriage-Spring.*—A carriage-spring is usually a beam of constant breadth ( $b$ ) and variable depth, built up of a number of overlapping plates each of thickness  $d$  (see Fig. 122a), the number decreasing outwards from the centre to the ends. The load  $W$  is taken at the middle, and the two ends are supported.

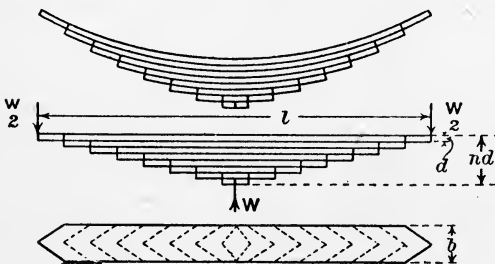

FIG. 122a.—Carriage spring.

Every strip of plate has initially the same curvature  $\left( \frac{1}{R} \right)$ , and the

proof load is usually that which straightens all the plates together, so that the change of curvature in each strip is the same. If there are  $n$  strips, the modulus of section of each being  $\frac{1}{6}bd^2$  (see Art. 66), the modulus of section of the whole spring at the centre will be  $\frac{n}{6}bd^2$ , and not  $\frac{1}{6}b(nd)^2$ , since the strips are separate, and if the proof stress in each



strip is  $f$  tons per square inch, the bending moment being  $\frac{1}{4}Wl$  (see Fig. 63)—

$$f = \frac{1}{4}Wl \div \frac{n}{6}bd^2 = \frac{3}{2} \frac{Wl}{nbd^2} \dots \dots \dots (10)$$

If this intensity of stress is to be reached by every plate at every transverse section of the spring, the modulus of section must be everywhere proportional to the bending moment, *i.e.* from the end to the centre it must be proportional to the distance from the end. The modulus of section at any section is proportional to the number of plates there, so that this number must increase from the ends to the centre proportionally to the distance (see Fig. 122*a*). The overlapping ends may be tapered in breadth, as in Fig. 122*a*, to give the same continuous rate of change of moment of resistance between abrupt changes in the number of plates. Every plate will then reach the same skin stress intensity  $f$  at every section, and will exert the same moment of resistance, *viz.*  $\frac{1}{8}fbd^2$ , at every section, corresponding to a bending moment  $\frac{1}{n} \cdot \frac{Wl}{4}$ .

Evidently, then, the change of curvature  $\frac{1}{R}$ , which is  $f \div \frac{dE}{2}$  (or  $\frac{M}{EI}$  or  $\frac{1}{n} \frac{Wl}{4} \div \frac{Ebd^3}{12}$ ), should be the same for each plate. The central deflection due to a central load may be found from that for the longest plate, which, by Art. 76, is—

$$\frac{1}{8} \frac{Ml^2}{EI} = \frac{1}{8} \frac{Wl}{4n} \cdot \frac{l^2}{E} \cdot \frac{12}{bd^3} = \frac{3}{8} \frac{Wl^3}{nEbd^3} \dots \dots \dots (11)$$

Actually the deflection will be less than this with an increasing load and more with a decreasing load, due to friction between the plates.

EXAMPLE 3.—A steel carriage-spring is to be 30 inches long, and to carry a central load of  $\frac{1}{2}$  ton. If the plates are 3 inches wide and  $\frac{1}{4}$  inch thick, how many plates will be required if the stress is to be limited to 12 tons per square inch? What will be the deflection of the spring at the centre? By how much will any one plate overlap the one below it at each end, and to what radius should each piece be curved?

If  $n$  plates are used—

$$12 \times n \times \frac{1}{6} \times 3 \times \left(\frac{1}{4}\right)^2 = \frac{1}{4} \times \frac{1}{2} \times 30$$

$n = 10$  plates

The central deflection, neglecting friction, will be—

$$\frac{3}{8} \times \frac{1}{2} \times \frac{27,000 \times 64}{10 \times 13,000 \times 3} = \frac{54}{65} = 0.83 \text{ inch}$$

Considering half the spring, the overlaps will be—

$$15 \div 10 = 1.5 \text{ inch}$$

The radius of curvature of each strip, if each is to straighten at proof load, may be found from that of the longest strip from Fig. 109, neglecting  $PP'^2$  or  $(0.83)^2$ —

$$0.83 \times 2R = 15 \times 15 \quad \text{hence } R = 135.5 \text{ inches}$$

or thus for the longest strip—

$$\frac{1}{R} = \frac{M}{EI} = \frac{1}{10} \times \frac{1}{4} \times \frac{1}{2} \times 30 \times \frac{12}{13,000 \times 3 \times (\frac{1}{4})^3} = \frac{1}{135.5}$$

#### EXAMPLES VI.

1. A railway axle is 4 inches diameter and the wheels are 4 feet  $8\frac{1}{2}$  inches apart; the centres of the axle boxes are each 6 inches outside of the wheel centres, and each axle box carries a load of 5 tons. Find the upward deflection of the centre of the axle. ( $E = 13,000$  tons per square inch.)

2. A beam of I section, 14 inches deep, is simply supported at the ends of a 20-foot span. If the moment of inertia of the area of cross-section is 440 (inches)<sup>4</sup>, what load may be hung midway between the supports without producing a deflection of more than  $\frac{1}{4}$  inch, and what is the intensity of bending stress produced? What total uniformly distributed load would produce the same deflection, and what would then be the maximum intensity of bending stress? ( $E = 13,000$  tons per square inch.)

3. A beam is simply supported at its ends and carries a uniformly distributed load  $W$ . At what distance below the level of the end supports must a rigid central prop be placed if it is to carry half the total load? If the prop so placed is elastic and requires a pressure  $e$  to depress it unit distance, what load would it carry, the end supports remaining rigid?

4. A beam rests on supports 20 feet apart and carries a distributed load which varies uniformly from 1 ton per foot at one support to 4 tons per foot at the other. Find the position and magnitude of the maximum deflection if the moment of inertia of the area of cross-section is 2654 (inches)<sup>4</sup>, and  $E$  is 13,000 tons per square inch.

5. A cantilever carries a load  $W$  at the free end and is supported in the middle to the level of the fixed end. Find the load on the prop and the deflection of the free end.

6. A cantilever carries a load  $W$  at half its length from the fixed end. The free end is supported to the level of the fixed end. Find the load carried by this support, the bending moment under the load and at the fixed end, and the position and amount of the maximum deflection.

If this cantilever is of steel, the moment of inertia of cross-section being 20 (inches)<sup>4</sup>, and the length 30 inches, find what proportion of the load would be carried by an end support consisting of a vertical steel tie-rod 10 feet long and  $\frac{1}{2}$  a square inch in section, if the free end is just at the level of the fixed end *before* the load is placed on the beam.

7. A cantilever carries a uniformly spread load  $W$ , and is propped to the level of the fixed end at a point  $\frac{3}{4}$  of its length from the fixed end. What proportion of the whole load is carried on the prop?

8. A cantilever carries a distributed load which varies uniformly from  $w$  per unit length at the fixed end to zero at the free end. Find the deflection at the free end.

9. A girder of I section rests on two supports 16 feet apart and carries a load of 6 tons 5 feet from one support. If the moment of inertia of the area

of cross-section is 375 (inches)<sup>4</sup>, find the deflection under the load and at the middle of the span, and the position and amount of the maximum deflection. ( $E = 13,000$  tons per square inch.)

10. If the beam in the previous problem carries an additional load of 8 tons 8 feet from the first one, and is propped at the centre to the level of the ends, find the load on the prop. By how much will it be lessened if the prop sinks 0.1 inch?

11. A girder of 16 feet span carries loads of 7 and 6 tons 4 and 6 feet respectively from one end. Find the position of the maximum deflection and its amount if the moment of inertia of the cross-section is 345 (inches)<sup>4</sup> and  $E = 13,000$  tons per square inch.

12. A steel beam 20 feet long is suspended horizontally from a rigid support by three vertical rods each 10 feet long, one at each end and one midway between the other two. The end rods have a cross-section of 1 square inch and the middle one has a section of 2 square inches, and the moment of inertia of cross-section of the beam is 480 (inches)<sup>4</sup>. If a uniform load of 1 ton per foot run is placed on the beam, find the pull in each rod.

13. A cantilever carries a uniformly distributed load throughout its length and is propped at the free end. What fraction of the load should the prop carry if the intensity of bending stress in the cantilever is to be the least possible, and what proportion does this intensity of stress bear to that in a beam propped at the free end exactly to the level of the fixed end?

14. At what fraction of its length from the free end should a uniformly loaded cantilever be propped to the level of the fixed end in order that the intensity of bending stress shall be as small as possible, and what proportion does this intensity of stress bear to that in a beam propped at the end to the same level? What proportion of the whole load is carried by the prop?

15. A cast-iron girder is simply supported at its ends and carries a uniformly distributed load. What proportion of the deflection at mid-span may be removed by a central prop without causing tension in the compression flange? What proportion of the deflection at  $\frac{1}{4}$  span may be removed by a prop there under a similar restriction?

16. A beam, AB, carries a uniform load of 1 ton per foot run and rests on two supports, C and D, so that  $AC = 3$  feet,  $CD = 10$  feet, and  $DB = 7$  feet. Find the deflections at A, B, and F from the level of the supports, F being midway between C and D.  $I = 375$  (inches)<sup>4</sup>.  $E = 13,000$  tons per square inch. How far from A is the section at which maximum upward deflection occurs?

17. If the beam in the previous problem carries loads of 5, 3, and 4 tons at A, F, and B respectively, and no other loads, find the deflections at A, F, and B, and the section at which maximum deflection occurs.

18. A cantilever is rectangular in cross-section, being of constant breadth and depth, varying uniformly from  $d$  at the wall to  $\frac{1}{2}d$  at the free end. Find the deflection of the free end of the cantilever due to a load  $W$  placed there, the moment of inertia of section at the fixed end being  $I_0$ .

19. A vertical steel post is of hollow circular section, the lower half of the length being 4 inches external and  $3\frac{1}{2}$  inches internal diameter, and the upper half 3 inches external and  $2\frac{1}{2}$  inches internal diameter. The total length of the post is 20 feet, the lower end being firmly fixed. Find the deflection of the top of the post due to a horizontal pull of 125 lbs., 4 feet from the top. ( $E = 30,000,000$  lbs. per square inch.)

20. A beam rests on supports at its ends and carries a load  $W$  midway between them. The moment of inertia of its cross-sectional area is  $I_0$  at mid-span, and varies uniformly along the beam to  $\frac{1}{2}I_0$  at each end. Find an expression for the deflection midway between the supports.

21. Find the deflection midway between the supports of the beam in the previous problem if the load  $W$  is uniformly spread over the span.

22. A carriage-spring is to be 2 feet long and made of  $\frac{3}{8}$ -inch steel plates 2 inches broad. How many plates are required to carry a central load of 1000 lbs. without exceeding a stress of 15 tons per square inch? What would then be the central deflection, and what should be the initial radius of curvature if the plates all straighten under this load? ( $E = 30,000,000$  lbs. per square inch.)

23. A carriage-spring is built up of 10 plates each  $\frac{1}{2}$  inch thick and 4 inches broad, the longest being 4 feet long. If the deflection necessary to straighten the spring is 1.5 inches, what central load will cause this deflection, and what is the intensity of stress produced in the metal,  $E$  being taken as 13,000 tons per square inch?

## CHAPTER VII.

### BUILT-IN AND CONTINUOUS BEAMS.

84. Built-in or Encasté Beams.—By this term is understood a beam firmly fixed at each end so that the supports completely constrain the inclination of the beam at the ends, as in the case of the “fixed” end of a cantilever. The two ends are usually at the same level, and the slope of the beam is then usually zero at each end if the constraint is effectual. The effect of this kind of fastening on a beam of uniform section is to make it stronger and stiffer, *i.e.* to reduce the maximum intensity of stress and to reduce the deflection everywhere. When the beam is loaded the bending moment is not zero at the ends as in the case of a simply supported beam, the end fastening imposing such “fixing moments” as make the beam convex *upwards* at the ends, while it is convex downwards about the middle portion, the bending moment passing through zero and changing sign at two points of contraflexure.

If the slope is zero at the ends, the necessary fixing couples at the ends are, for distributed loads, the greatest bending moments anywhere on the beam. Up to a certain degree, relaxation of this clamping, which always takes place in practice when a steel girder is built into masonry, tends to reduce the greatest bending moment by decreasing the fixing moments and increasing the moment of opposite sign about the middle of the span. In a condition between perfect fixture and perfect freedom of the ends, the beam may be subject to smaller bending stresses than in the usual ideal form of a built-in beam with rigidly fixed ends. The conditions of greatest strength will be realized when the two greatest convexities are each equal to the greatest concavity, the greatest bending moments of opposite sign being equal in magnitude.

Simple cases of continuous loading of built-in beams where the rate of loading can be easily expressed algebraically may be solved by integration of the fundamental equation—

$$EI \frac{d^4y}{dx^4} = w \quad (\text{Art. 77})$$

Taking one end of the beam as origin, the conditions will usually be

$$\frac{dy}{dx} = 0 \text{ for } x = 0 \text{ and for } x = l, \text{ and } y = 0 \text{ for } x = 0 \text{ and for } x = l.$$

For example, suppose that the load is uniformly distributed, being  $w$  per unit length of span, integrating the above equation—

$$EI \cdot \frac{d^3y}{dx^3} = wx + A$$

$$EI \cdot \frac{d^2y}{dx^2} = \frac{1}{2}wx^2 + Ax + B$$

$$EI \cdot \frac{dy}{dx} = \frac{1}{6}wx^3 + \frac{1}{2}Ax^2 + Bx + C$$

since  $\frac{dy}{dx} = 0$  for  $x = 0$ , and putting  $\frac{dy}{dx} = 0$  for  $x = l$ —

$$0 = \frac{1}{6}wl^2 + \frac{1}{2}Al + B \quad \text{and} \quad B = -\frac{1}{6}wl^2 - \frac{1}{2}Al$$

$$EI \cdot \frac{dy}{dx} = \frac{1}{6}wx^3 + \frac{1}{2}Ax^2 - \frac{1}{6}wl^2x - \frac{1}{2}Alx$$

$$EI \cdot y = \frac{1}{24}wx^4 + \frac{1}{6}Ax^3 - \frac{1}{12}wl^2x^2 - \frac{1}{4}Alx^2 + Cx$$

since  $y = 0$  for  $x = 0$ , and putting  $y = 0$  for  $x = l$ , and dividing by  $l^3$ —

$$0 = \frac{1}{24}wl - \frac{1}{12}wl + \frac{1}{6}A - \frac{1}{4}A$$

hence  $A = -\frac{1}{2}wl$  and  $B = \frac{1}{12}wl^2$

Substituting these values in the above equations, the values of the shearing force, bending moment, slope, and deflection everywhere are found, viz.—

$$F = EI \frac{d^3y}{dx^3} = w(x - \frac{1}{2}l)$$

$$M = EI \frac{d^2y}{dx^2} = \frac{1}{12}w(6x^2 - 6lx + l^2)$$

which reaches a zero value for  $x = l(\frac{1}{3} \pm 0.289)$ , *i.e.*  $0.289l$ , on either side of mid-span. Also for  $x = 0$ , or  $x = l$ ,  $M = \frac{1}{12}wl^2$ , and for  $x = \frac{l}{2}$   $M = -\frac{1}{24}wl^2$ ,

$$i = \frac{dy}{dx} = \frac{w}{12EI}(2x^3 - 3lx^2 + l^2x)$$

which reaches zero for  $x = 0$ ,  $x = l$ , and  $x = \frac{l}{2}$

$$y = \frac{w}{24EI} \cdot x^2(l-x)^2$$

and at the centre, where  $x = \frac{l}{2}$ , the deflection is—

$$\frac{1}{24} \frac{w}{EI} \cdot \left(\frac{l}{2}\right)^2 \cdot \left(\frac{l}{2}\right)^2 = \frac{1}{384} \frac{wl^4}{EI}$$

or  $\frac{1}{5}$  of that for a freely supported beam (see (12), Art. 78).

The bending-moment diagram is shown in Fig. 123; it should be noticed that the bending moment varies in the same way as if the ends were free, varying from  $+\frac{1}{2}wl^2$  to  $-\frac{1}{2}wl^2$ , a change of  $\frac{1}{8}wl^2$ , as in the freely supported beam (see Fig. 65), but the greatest bending moment to which the beam is subjected is only  $\frac{1}{12}wl^2$  instead of  $\frac{1}{8}wl^2$ , so that with the same cross-section the greatest intensity of direct bending stress will be reduced in

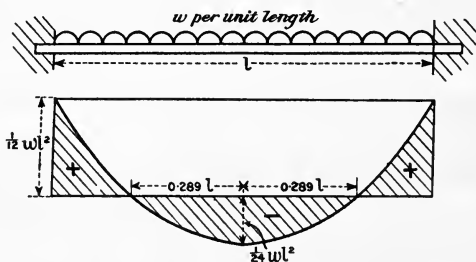

FIG. 123.

the ratio 3 to 2. The greatest bending moment and greatest shearing force ( $\frac{1}{2}wl$ ) here occur at the same section. Evidently, to attain the greatest flexural strength the bending moment at the centre should be equal to that at the ends, each being half of  $\frac{1}{8}wl^2$ . In this case the equation to the bending-moment curve would be, from (7), Art. 78—

$$M = EI \frac{d^2y}{dx^2} = \frac{1}{2}wx^2 - \frac{1}{2}wlx + \frac{1}{16}wl^2$$

the last or constant term alone differing from the equation used above. Integrating this twice and putting  $y = 0$  for  $x = 0$  and for  $x = l$ , or integrating once and putting  $\frac{dy}{dx} = 0$  for  $x = \frac{l}{2}$  because of the symmetry, the necessary slope at the ends is found to be  $\frac{1}{96} \frac{wl^3}{EI}$  or  $\frac{1}{4}$  of that in a beam freely supported at its ends (see (10), Art. 78).

Other types of loading where  $w$  is a simple function of  $x$  may be easily solved by this method.

As another example, suppose that  $w = 0$ , but one end support sinks a distance  $\delta$ , both ends remaining fixed horizontally. Taking the origin at the end which does not sink—

$$EI \cdot \frac{d^4y}{dx^4} = 0$$

$$EI \cdot \frac{d^3y}{dx^3} = F$$

where  $F$  is the (constant) shearing force throughout the span,

$$EI \cdot \frac{d^2y}{dx^2} = Fx + m$$

where  $m$  is the bending moment for  $x = 0$

$$EI \cdot \frac{dy}{dx} = \frac{1}{2}Fx^2 + mx + 0$$

and putting  $\frac{dy}{dx} = 0$  for  $x = l$ ,

$$m = -F \frac{l}{2}$$

and

$$EI \cdot \frac{dy}{dx} = \frac{1}{2}F(x^2 - lx)$$

$$EI \cdot y = \frac{1}{2}F \left( \frac{x^3}{3} - \frac{lx^2}{2} + 0 \right)$$

and putting  $y = \delta$  for  $x = l$ —

$$EI \cdot \delta = \frac{Fl^3}{2} \left( \frac{1}{3} - \frac{1}{2} \right) = -\frac{1}{12}Fl^3$$

$$F = -\frac{12EI\delta}{l^3} \quad m = \frac{6EI\delta}{l^2}$$

and the bending moment anywhere is—

$$\frac{6EI \cdot \delta}{l^2} - \frac{12EI \cdot x \cdot \delta}{l^3}$$

a straight line reaching the value  $-\frac{6EI\delta}{l^2}$  at  $x = l$ . The equal and opposite vertical reactions at the supports are each of magnitude  $F$ .

**85. Effect of Fixed Ends on the Bending-Moment Diagram.**—In a built-in beam the effect of the fixing moments applied at the walls

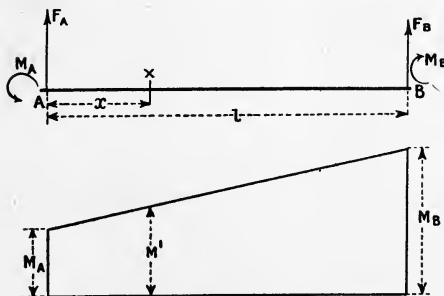

FIG. 124.—Effect of fixing couples.

or piers when a load is applied, if acting alone, would be to make the beam convex upwards throughout. Suppose only these “fixing couples” act on the beam, the bending moment due to them at any point of the span may easily be found by looking on the beam as one simply supported, but overhanging the supports at each end and carrying such loads on the overhanging ends as would produce at the

supports the actual fixing moments of the built-in beam. If these fixing moments are equal they produce a bending moment of the same magnitude throughout the span (see Fig. 67). If the fixing moments at the two ends are unequal, being say  $M_A$  at one end A (Fig. 124) and  $M_B$  at the other end B, the bending moment throughout the span varies from  $M_A$  to  $M_B$  as a straight-line diagram, *i.e.* at a constant rate along the span, as the reader will find by sketching the diagram of bending moments for a beam overhanging its two supports and carrying end



loads. At a distance  $x$  from A the bending moment due to fixing couples will be—

$$M' = M_A + \frac{x}{l}(M_B - M_A) \quad (\text{see Fig. 124})$$

The actual bending moment at any section of a built-in beam will be the algebraic sum of the bending moment which would be produced by the load on a freely supported beam, and the above quantity  $M'$ .

Without any supposition of the case of an overhanging beam, we may put the result as follows for any span of a beam not "free" at the ends.

Let  $F_A$  (Fig. 124) be the shearing force just to the right of A, and  $F_B$  the shearing force just to the left of B,  $M_A$  and  $M_B$  being the moments imposed by the constraints at A and B respectively. Let  $w$  be the load per unit length of span whether constant or variable. Then, as in Art. 77, with A as origin—

$$\frac{d^2M}{dx^2} = w \quad \dots \quad (1)$$

$$F \text{ or } \frac{dM}{dx} = \int_0^x w dx + F_A \quad \dots \quad (2)$$

$F_A$  being the value of  $F$  for  $x = 0$ .

$$\text{Then } M = \int_0^x \int_0^x w dx dx + F_A \cdot x + M_A \quad \dots \quad (3)$$

$M_A$  being the value of  $EI \frac{d^2y}{dx^2}$  for  $x = 0$ . Putting  $x = l$ —

$$M_B = \int_0^l \int_0^l w dx dx + F_A l + M_A$$

$$\text{hence } F_A = \frac{M_B - M_A}{l} - \frac{1}{l} \int_0^l \int_0^l w dx dx \quad \dots \quad (4)$$

Note that the term  $\frac{1}{l} \int_0^l \int_0^l w dx dx$  is the value of the reaction at A if

$M_B = M_A$ , or if both are zero as in the freely supported beam.

Substituting the value of  $F_A$  in (3)—

$$EI \frac{d^2y}{dx^2} \text{ or } M = \int_0^x \int_0^x w dx dx + (M_B - M_A) \frac{x}{l} + M_A - \frac{x}{l} \int_0^l \int_0^l w dx dx \quad (5)$$

or re-arranging—

$$M = M_A + (M_B - M_A) \frac{x}{l} + \int_0^x \int_0^x w dx dx - \frac{x}{l} \int_0^l \int_0^l w dx dx \quad (6)$$

With free ends  $M_A = M_B = 0$ , and—

$$M = \int_0^x \int_0^x w dx dx - \frac{x}{l} \int_0^l \int_0^l w dx dx$$

and if the ends are not free there is the additional bending moment, which may be written—

$$M' = M_A + (M_B - M_A) \frac{x}{l} \quad \dots \quad (7)$$

or, 
$$M' = M_A \cdot \frac{l-x}{l} + M_B \cdot \frac{x}{l} \quad \dots \quad (7a)$$

a form which will be used in Arts. 87 and 89.

With this notation (5) may be written—

$$EI \frac{d^2y}{dx^2} = M + M' = M + M_A + (M_B - M_A) \frac{x}{l} \quad \dots \quad (8)$$

where  $M$  is the bending moment at any section for a freely supported beam similarly loaded, and  $M'$  is the bending moment (Fig. 124) at that section due to the fixing moments  $M_A$  and  $M_B$  at the ends. Usually  $M$  and  $M'$  will be of opposite sign; if the magnitudes of  $M$  and  $M'$  are then

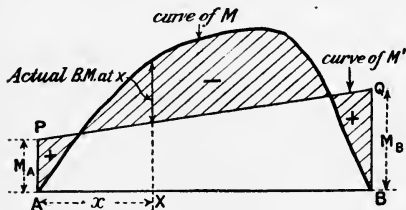

FIG. 125.

plotted on the same side of the same base-line, the actual bending moment at any section is represented by the ordinates giving the difference between the two curves (see Fig. 125). The conventional algebraic signs used in the above integrations (see Art. 77) make  $M$  negative for concavity upwards. The reactions  $R_A (= -F_A)$

and  $R_B$  may be found from equation (4). If  $M_B - M_A$  is positive, the reaction at  $A$  is less (in magnitude) than it would be for a simply supported beam by  $\frac{1}{l}(M_B - M_A)$ , and the reaction at  $B$  is greater than for a simply supported beam by the same amount.

**86. Built-in Beam with any Symmetrical Loading.**—For a symmetrically loaded beam of constant cross-section the fixing couples at the supports are evidently equal, and Fig. 67 shows that equal couples at the ends of a span cause a bending moment of the same amount throughout. Or, from (7), Art. 85, if  $M_B = M_A$ ,  $M' = M_A = M_B$  at every section. Hence, the resulting ordinates of the bending-moment diagram (see Art. 85) will consist of the difference in ordinates of a rectangle (the trapezoid  $APQB$ , Fig. 125, being a rectangle when  $M_A = M_B$ ) and those of the curve of bending moments for the same span and loading with freely supported ends. And since between limits—

$$\frac{dy}{dx} \quad \text{or} \quad i = \int \frac{M}{EI} \cdot dx \quad (\text{see (3), Art. 77})$$

if  $E$  and  $I$  are constant, the change of slope  $\frac{1}{EI} \int_0^l M dx$  between the two ends of the beam is—

$$\frac{1}{EI} \int_0^l (M + M') dx$$

with the notation of the previous article, where  $l$  is the length of span and the origin is at one support. Now in a built-in beam, if both ends are fixed horizontally, the change of slope is zero, hence—

$$\left. \begin{aligned} \int_0^l (M + M') dx &= 0 \\ \text{or,} \quad - \int_0^l M' dx &= \int_0^l M dx \\ \text{or,} \quad - M' &= \frac{1}{l} \int_0^l M dx \end{aligned} \right\} \dots \dots (1)$$

This may also be written—

$$A + A' = 0 \dots \dots \dots (2)$$

where  $A$  stands for the area of the  $M$  curve, and  $A'$  stands for the area of the trapezoid  $APQB$  or  $M'$  curve (Fig. 125), which in this special case is a rectangle,  $AA'BB'$  (Fig. 126).

$\int_0^l (M + M') dx$  represents the area of the bending-moment diagram for the whole length of span, and equation (1) shows that the total area is zero. Hence the rectangle of height  $M_A$  (or  $M'$ ), and the bending-moment diagram  $M$  for the simply supported beam have the same area  $-A$ , and the constant value ( $M_A$ ) of  $M'$  is  $-\frac{1}{l} \int_0^l M dx$ ;

the ordinate representing it is  $-\frac{A}{l}$ ,  $A$  and  $M$  being generally negative.

Hence, to find the bending-moment diagram for a symmetrically loaded beam, first draw the bending-moment diagram as if the beam were simply supported ( $ACDC'B$ ,

Fig. 126), and then reduce all ordinates by the amount of the average ordinate, or, in other words, raise the base-line  $AB$  by an amount  $M_A$ , which is represented by the mean ordinate of the diagram  $ACDC'B$ , or (area  $ACDC'B$ )  $\div$  (length  $AB$ ). The points  $N$  and  $N'$  vertically under  $C$  and  $C'$  are points of contraflexure or zero bending moment, and the areas  $AA'C$  and  $BB'C'$  are together equal to the area  $CDC'$  and of opposite sign. With downward load, the downward slope from  $A$  to  $N$  increases and is at  $N$  proportional to the area  $AA'C$ . From  $N$  towards mid-span the slope decreases, becoming zero at mid-span when the net area of the bending-moment diagram from  $A$  is zero, *i.e.* as much area is positive as negative.

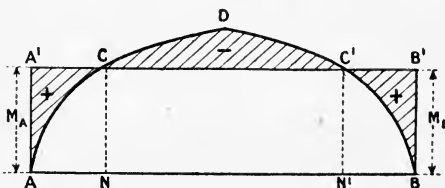

FIG. 126.

The slopes and deflections may be obtained from the resulting bending-moment diagram by the methods of Art. 81, taking account of the sign of the areas. Or the methods of Art. 82 may be employed, remembering the opposite signs of the different parts of the bending-moment diagram area, and that the slope and deflection are zero at the ends. Another possible method is to treat the portion NN' between the points of contraflexure (or virtual hinges) as a separate beam supported at its ends on the ends of two cantilevers, AN and BN'.

If the slopes at the ends A and B are not zero, but are fixed at equal magnitudes  $i$  and of opposite sign, both being downwards towards the centre, slopes being reckoned positive downwards to the right, equation (1) becomes—

$$\int_0^l (M + M') dx = -2i \cdot EI$$

$$\text{and } \int_0^l M' dx = -\int_0^l M dx - 2i \cdot EI \quad \text{or} \quad M' = -\frac{1}{l} \int_0^l M dx - \frac{2i \cdot EI}{l}$$

M being usually negative, and for minimum intensity of bending stress this value of  $M'$  should be equal in magnitude to half the maximum value of M.

EXAMPLE 1.—Uniformly distributed load  $w$  per unit span on a built-in beam. The area of the parabolic bending-moment diagram for a simply supported beam (see Fig. 65) is—

$$\frac{2}{3} \times \frac{1}{8} wl^2 \times l = \frac{1}{12} wl^3$$

The mean bending moment is therefore  $\frac{1}{12} wl^2$ . By reducing all ordinates of Fig. 65 by the amount  $\frac{1}{12} wl^2$ , we get exactly the same diagram as shown in Fig. 123.

EXAMPLE 2.—Central load  $W$  on a built-in beam.

The bending-moment diagram for the simply supported beam is shown in Fig. 63. Its mean height is proportional to  $\frac{1}{2} \cdot \frac{Wl}{4}$  or  $\frac{Wl}{8}$ .

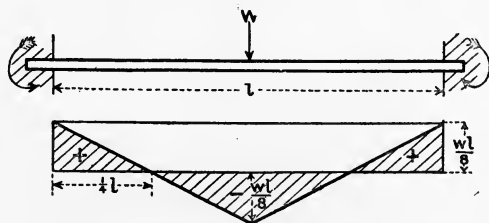

FIG. 127.

Hence for the built-in beam the bending-moment diagram is as shown in Fig. 127. The points of contraflexure are evidently  $\frac{1}{4}l$  from each end, and the bending moments at the ends and centre are  $\frac{Wl}{8}$ .

Taking the origin at the centre or either end, using the method of

Art. 81 (3) and taking account of the signs,  $\frac{dy}{dx}$  vanishes at both limits and  $y$  at one limit, and the central deflection under the load is—

$$\frac{I}{EI} \left\{ \left( \frac{1}{2} \cdot \frac{Wl}{8} \times \frac{l}{4} \right) \left( \frac{l}{2} - \frac{1}{3} \cdot \frac{l}{4} \right) - \left( \frac{1}{2} \cdot \frac{Wl}{8} \cdot \frac{l}{4} \right) \left( \frac{1}{3} \cdot \frac{l}{4} \right) \right\} = \frac{Wl^3}{192EI}$$

87. Built-in Beams with any Loading.—As in the previous article, and with the same notation, if  $I$  and  $E$  are constant—

$$\int_0^l (M + M') dx = 0 \quad \dots \dots \dots (1)$$

or,  $A + A' = 0$

or, substituting for  $M'$  its value from (7), Art. 85—

$$\int_0^l \left\{ M + M_A + (M_B - M_A) \frac{x}{l} \right\} dx = 0 \quad \dots \dots (2)$$

The loading being not symmetrical,  $M_B$  is not necessarily equal to  $M_A$ , and the area  $A'$  is not a rectangle but a trapezoid (Fig. 128), and the equation of areas  $A$  and  $-A'$  is insufficient to determine the two fixing couples  $M_A$  and  $M_B$ . We may, however, very conveniently proceed by the method used in Art. 81 to establish a second relation. Thus, taking one end of the span, say  $A$ , Fig. 128, as origin—

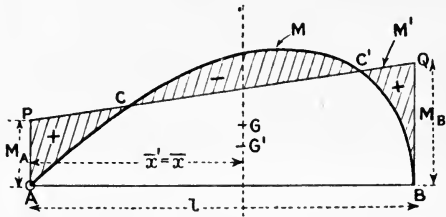

FIG. 128.

$$\frac{d^2y}{dx^2} = \frac{M + M'}{EI}$$

and multiplying by  $x$  and integrating (by parts), with limits  $l$  and  $0$ —

$$\left( x \frac{dy}{dx} - y \right)_0^l = \frac{I}{EI} \int_0^l (M + M') x dx = \frac{I}{EI} \left( \int_0^l M x dx + \int_0^l M' x dx \right)$$

or, 
$$EI \left( x \frac{dy}{dx} - y \right)_0^l = A \bar{x} + A' \bar{x}'$$

where  $\bar{x}$  and  $\bar{x}'$  are the respective distances of the centres of gravity or centroids of the areas  $A$  and  $A'$  from the origin. Further, the term—

$$\left( x \frac{dy}{dx} - y \right)_0^l$$

is obviously zero, since each part of it vanishes at both limits  $x = l$  and  $x = 0$ ; hence—

$$A \bar{x} + A' \bar{x}' = 0 = \int_0^l M x dx + \int_0^l M' x dx \quad \dots \dots (3)$$

or the moments about either support of the areas A and A' are equal in magnitude, in addition to the areas themselves being equal, or, in other words, their centroids are in the same vertical line (see Fig. 128).

Evidently, from Fig. 128, the area APQB or A' =  $\frac{M_A + M_B}{2} \times l$ , hence from (1)—

$$\frac{M_A + M_B}{2} \cdot l = -A \dots \dots (4)$$

and, taking moments about the point A (Fig. 128), dividing the trapezoid into triangles by a diagonal PB—

$$A'\bar{x}' = (\frac{1}{2}M_A \cdot l \cdot \frac{1}{3}l) + (\frac{1}{2}M_B \cdot l \cdot \frac{2}{3}l) = \frac{1}{6}l^2(M_A + 2M_B) \dots (4a)$$

or from (3),  $\frac{1}{6}l^2(M_A + 2M_B) = -A\bar{x} \dots \dots (5)$

or,  $M_A + 2M_B = -\frac{6}{l^2} \cdot A\bar{x}$

and from (4),  $M_A + M_B = -\frac{2}{l} \cdot A$

from which  $M_B = \frac{2A}{l} - \frac{6A\bar{x}}{l^2}$  or  $\frac{2A}{l} \left( 1 - \frac{3\bar{x}}{l} \right) \dots (6)$

$$M_A = 6\frac{A\bar{x}}{l^2} - 4\frac{A}{l} \text{ or } 2\frac{A}{l} \left( \frac{3\bar{x}}{l} - 2 \right) \dots (7)$$

Thus the fixing moments are determined in terms of the area of the bending-moment diagram (A) and its moment (A $\bar{x}$ ) about one support, or the distance of its centroid from one support. The trapezoid APQB (Fig. 128) can then be drawn, and the difference of ordinates between it and the bending-moment diagram for the simply supported beam gives the bending moments for the built-in beam. The resultant diagram is shown shaded in Fig. 128. With the convention as to signs used in Art. 77 the area A must be reckoned negative for values of M producing concavity upwards. With loading which gives a bending moment the area of which and its moment are easily calculated, M<sub>B</sub> and M<sub>A</sub> may be found algebraically or arithmetically from (6) and (7), and then the bending moment elsewhere found from the equation (8) of Art. 85. With irregular loading the process may be carried out graphically; the quantity A ·  $\bar{x}$  may then conveniently be found by a "derived area," as in Art. 68, Fig. 85, using the origin A as a pole, without finding  $\bar{x}$ .

When the resultant bending-moment diagram has been determined, either of the graphical methods of Art. 82 may be used to find the deflections or slopes at any point of the beam, taking proper account of the difference of sign of the areas and starting both slope and deflection curves from zero at the ends. Or the methods of Art. 81, (b) and (c), may be employed, taking account of the different signs in calculating slopes from the areas of the bending-moment diagram or deflections from the moments of such areas. When the bending moment has been

determined, the problem of finding slopes, deflections, etc., for the built-in beam is generally simpler than for the merely supported beam, because the end slopes are generally zero. The shearing-force diagram for the built-in beam with an unsymmetrical load changes from point to point just as for the corresponding simply supported beam (since  $\frac{dF}{dx} = w$ ), but the reactions at the ends are different, as shown by (4), Art. 85, one ( $R_B$ ) being greater in magnitude, and the other ( $R_A$ ) being less by the amount  $\frac{1}{l}(M_B - M_A)$ , which may be positive or negative.

If the ends of the beam are built in so that the end slopes are not zero, equation (1) becomes—

$$A + A' = EI(i_B - i_A)$$

where  $i_B$  and  $i_A$  are the fixed slopes at the ends B and A, and are reckoned positive if downward to the right (usually they will have opposite signs). Equation (3) then becomes—

$$A\bar{x} + A'\bar{x}' = EI \cdot l \cdot i_B$$

and the values of  $M_B$  and  $M_A$  are—

$$M_B = \frac{2A}{l} - \frac{6A\bar{x}}{l^2} + \frac{2(2i_B + i_A)EI}{l}, \quad M_A = \frac{6A\bar{x}}{l^2} - \frac{4A}{l} - 2 \frac{(i_B + 2i_A)EI}{l}$$

quantities which will be less in magnitude (the area A being negative) than (6) and (7) when both ends slope downwards towards the centre unless  $i_B$  and  $i_A$  are very unequal in magnitude. To secure the greatest possible flexural strength from a given section it would be necessary to make the two fixing bending moments  $M_B$  and  $M_A$  equal, and opposite to half the maximum bending moment for the freely supported beam. The necessary end slopes could more easily be calculated than secured in practice.

EXAMPLE 1.—A built-in beam of span  $l$  carries a load  $W$  at  $\frac{1}{4}l$  from one end. Find the bending-moment diagram, points of inflection, deflection under the load, and the position and magnitude of the maximum deflection.

For the simply supported beam the bending moment at C (Fig. 129) would be  $\frac{3}{4}W \times \frac{1}{4}l = \frac{3}{16}Wl$ . Then, dividing the bending-moment diagram into two parts, ADC and CDB, with origin at the point A and the above notation—

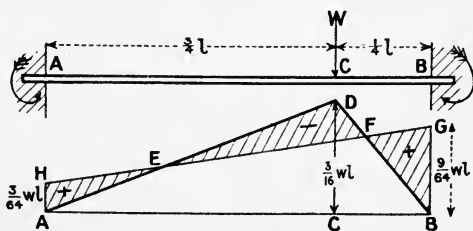

FIG. 129.

$$A. \bar{x} = - \left\{ \left( \frac{1}{2} \cdot \frac{3}{4} l \cdot \frac{3}{16} Wl \cdot \frac{2}{3} \cdot \frac{3}{4} l \right) + \left( \frac{1}{2} \cdot \frac{1}{4} l \cdot \frac{3}{16} Wl \right) \left( \frac{3}{4} l + \frac{1}{3} \cdot \frac{1}{4} l \right) \right\} = - \frac{7}{128} Wl^3$$

$$A = - \frac{1}{2} \cdot \frac{3}{16} Wl \cdot l = - \frac{3}{32} Wl^2$$

and from (6),

$$M_B = Wl \left( - \frac{3}{16} + \frac{21}{64} \right) = + \frac{9}{64} Wl$$

$$M_A = Wl \left( - \frac{21}{64} + \frac{3}{8} \right) = + \frac{3}{64} Wl$$

The resultant bending-moment diagram can now be completed by the line GH, Fig. 129.

Taking moments about B—

$$\frac{1}{4} Wl - R_A \cdot l + \frac{3}{64} Wl = \frac{9}{64} W \cdot l \quad R_A = \frac{5}{32} W \quad R_B = \frac{27}{32} W$$

from which the shearing-force diagram may be drawn.

For the larger segment A to C, with A as origin—

$$M = - \frac{1}{4} Wx$$

$$M + M' = M + M_A + \frac{x}{l} (M_B - M_A) = - \frac{1}{4} Wx + \frac{3}{64} Wl + \frac{3}{32} Wx$$

$$= W \left( \frac{3}{64} l - \frac{5}{32} x \right)$$

This vanishes for  $x = \frac{3}{10} l$ , which gives the point of inflection E (Fig. 129).

For the shorter segment C to B—

$$M = - \frac{3}{4} W(l - x)$$

$$M + M' = - \frac{3}{4} W(l - x) + \frac{3}{64} Wl + \frac{3}{32} Wx = W \left( - \frac{45}{64} l + \frac{27}{32} x \right)$$

This vanishes for  $x = \frac{5}{6} l$ , which gives the point of inflection F.

Slopes from A to C reckoned positive downwards to the right—

$$i = \frac{W}{EI} \int_0^x \left( - \frac{5}{32} x + \frac{3}{64} l \right) dx = \frac{W}{64EI} (-5x^2 + 3lx)$$

This vanishes for  $x = \frac{3}{5} l$ , which gives the position of the point of maximum deflection. That its distance from A is twice that of the point of inflection under E is evident from a glance at the bending-moment diagram, Fig. 129.

For  $x = \frac{3}{4} l$  at C—

$$i_C = \frac{Wl^2}{64EI} \left( -5 \times \frac{9}{16} + \frac{9}{4} \right) = - \frac{9}{1024} \cdot \frac{Wl^2}{EI}$$

Slopes from C to B—

$$i = i_C + \frac{W}{EI} \int_{\frac{3}{4}l}^x \left( - \frac{45}{64} l + \frac{27}{32} x \right) dx = - \frac{9}{1024} \frac{Wl^2}{EI} + \frac{W}{64EI} (-45lx + 27x^2)_{\frac{3}{4}l}^x$$

which does not reach zero for any value of  $x$  between  $\frac{3}{4} l$  and  $l$ .

Deflections from A to C—

$$y = \int i dx = \frac{W}{64EI} \int_0^x (-5x^2 + 3lx) dx = \frac{W}{64EI} \left( -\frac{5}{3} x^3 + \frac{3}{2} lx^2 \right)$$



and at C, where  $x = \frac{3}{4}l$ —

$$y_c = +\frac{9}{4096} \cdot \frac{Wl^3}{EI}$$

and at  $x = \frac{3}{5}l$ ,

$$y'_{\max.} = +\frac{9}{3200} \cdot \frac{Wl^3}{EI}$$

at  $x = \frac{l}{2}$ ,

$$y = +\frac{1}{384} \cdot \frac{Wl^3}{EI}$$

Deflections from C to B—

$$\begin{aligned} y &= y_c + \int_{\frac{3}{4}l}^x i \cdot dx = +\frac{9}{4096} \cdot \frac{Wl^3}{EI} + \frac{W}{64EI} \int_{\frac{3}{4}l}^x (18l^2 - 45lx + 27x^2) dx \\ &= \frac{W}{64EI} \left\{ +\frac{9}{64}l^3 + (18l^2x - \frac{45}{2}lx^2 + 9x^3) \right\} \\ &= \frac{9W}{128EI} (2x^3 - 5lx^2 + 4l^2x - l^3) \end{aligned}$$

EXAMPLE 2.—The more general problem of a load  $W$  on a built-in

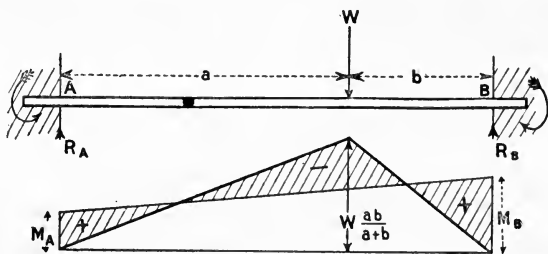

FIG. 130.

beam, placed at distances  $a$  from one support A and  $b$  from the other B, may be solved in just the same way.

If  $a$  is greater than  $b$ , and A is the origin (Fig. 130)—

$$\begin{aligned} M_A &= \frac{Wab^2}{(a+b)^2} & M_B &= \frac{Wa^2b}{(a+b)^2} \\ R_A &= W \frac{b^2(3a+b)}{(a+b)^3} & R_B &= W \frac{a^2(a+3b)}{(a+b)^3} \end{aligned}$$

The points of inflection are at—

$$x = \frac{a}{3a+b}(a+b) \quad \text{and} \quad x = \frac{a+2b}{a+3b}(a+b)$$

The slope under the load is—

$$i = -\frac{Wa^2b^2(a-b)}{2EI(a+b)^3}$$

The zero slope and maximum deflection occurs at—

$$x = \frac{2a}{3a + b} (a + b)$$

and when  $b = 0$  this becomes  $\frac{2}{3}(a + b)$ , so that the maximum deflection is for the built-in beam always within the middle third of the span.

The deflection under the load is—

$$y = \frac{Wa^3b^3}{3EI(a + b)^3}$$

which is  $\frac{ab}{(a + b)^2}$  times that for a freely supported beam.

The maximum deflection is—

$$\frac{2}{3} \frac{Wa^3b^2}{(3a + b)^2EI}$$

and the deflection at mid-span is—

$$\frac{Wb^2(3a - b)}{48EI}$$

**88. Built-in Beams of Variable Section.**—Having considered in Art. 83 how simple beam-deflection problems are affected by a variable section, and in Art. 87 the case of built-in beams of constant section, it will be sufficient to point out briefly the modifications in the work of Art. 87 when the quantity  $I$  is not a constant. The change consists in using  $\frac{M}{I}$  instead of  $M$  as a variable throughout. Thus, with the same notation, since the total change of slope is zero—

$$\int_0^l \frac{d^2y}{dx^2} dx = \frac{1}{E} \int_0^l \frac{M + M'}{I} dx = \frac{1}{E} \int_0^l \left[ \frac{M}{I} + \frac{1}{I} \{ M_A + (M_B - M_A) \frac{x}{l} \} \right] dx = 0$$

$$\text{or, } \int_0^l \frac{M}{I} dx + M_A \int_0^l \frac{dx}{I} + \frac{M_B - M_A}{l} \int_0^l \frac{x}{I} dx = 0 \dots \dots (1)$$

also, since the total change of level is zero,  $\left( x \frac{dy}{dx} - y \right)_0^l$  is zero, or—

$$\frac{1}{E} \int_0^l \left( \frac{M + M'}{I} \right) x dx = \frac{1}{E} \int_0^l \left[ \frac{M}{I} + \frac{1}{I} \{ M_A + (M_A - M_B) \frac{x}{l} \} \right] x dx = 0$$

$$\text{or, } \int_0^l \frac{Mx}{I} dx + M_A \int_0^l \frac{x}{I} dx + \frac{M_B - M_A}{l} \int_0^l \frac{x^2}{I} dx = 0 \dots \dots (2)$$

Thus the areas under the curves  $\frac{M}{I}$  and  $\frac{M'}{I}$  are the same, and have their centroids in the same vertical line, but the curve  $\frac{M'}{I}$  is not generally a straight line, so that the second and third terms in each equation do

not reduce so simply as in the case of constant values of  $I$ . When  $M$  and  $I$  are known functions of  $x$ , each term of equations (1) and (2) may be integrated separately. This gives two simple simultaneous equations in which the unknown quantities are  $M_A$  and  $\frac{I}{\lambda}(M_A - M_B)$ . When these have been solved  $M_A$  and  $M^u$  are known.

If  $M$  varies in some irregular manner, or if the above integrals are too tedious, the integration of the quantities  $\frac{Mx}{I}$  and  $\frac{M}{I}$  may be performed graphically by plotting the curves  $\frac{Mx}{I}$  and  $\frac{M}{I}$  on the span as a base, and finding their areas from 0 to  $l$ .

Further, if  $I$  varies in some arbitrary but specified manner which cannot be expressed as a function of  $x$ , or which makes the above integrals cumbersome, the integration of all three terms in (1) and all three terms in (2) may be accomplished graphically by plotting the curves—

$$\frac{M}{I}, \quad \frac{I}{I}, \quad \frac{x}{I}, \quad \frac{Mx}{I}, \quad \frac{x}{I}, \quad \text{and} \quad \frac{x^2}{I}$$

on the span as a base and finding their areas from 0 to  $l$ . This involves five operations only, as the third and fifth curves are the same. It may be convenient to take  $\int_0^l \frac{x^2}{I} dx$  as  $\int_0^l \frac{x}{I} dx$  multiplied by the distance of the centroid of the area under the curve  $\frac{x}{I}$  from the origin  $A$ , or the moment of the area  $\int_0^l \frac{x}{I} dx$ , as found by the "derived area" method of Art. 68.

A similar statement applies to the pair of curves  $\frac{x}{I}$  and  $\frac{I}{I}$ , and to the pair  $\frac{Mx}{I}$  and  $\frac{M}{I}$ .

Note that the first terms in (1) and (2) will be negative, the sum  $M + M'$  being algebraic.

When  $M_A$  and  $M_B$  have been found, the bending-moment diagram may be plotted as in the case of constant values of  $I$ . The net area of the resultant bending moment will not necessarily be zero, nor will its moment about  $A$  or  $B$ .

If the slopes at the ends  $A$  and  $B$  (Fig. 128) are fixed at angles  $i_A$  and  $i_B$  other than zero, reckoned positive downwards to the right, the right-hand side of equation (1) becomes  $E(i_B - i_A)$ ,  $i_A$  and  $i_B$  being usually of opposite sign. And the right-hand side of equation (2) becomes  $E \cdot l \cdot i_B$ , the origin being at  $A$ .

*Special Case.*—If the loading is symmetrical about the middle of the span, and the values of  $I$  are also symmetrical about mid-span, the centroids of the  $\frac{M}{I}$  and  $\frac{M'}{I}$  diagrams being at  $\frac{l}{2}$  from each end,  $M_A = M_B$ , and equation (1) becomes—

$$\int_0^l \frac{M}{I} dx + M_A \int_0^l \frac{dx}{I} = 0$$

$$M_A = M_B = - \int_0^l \frac{M}{I} dx \div \int_0^l \frac{dx}{I}$$

and since the beam is horizontal at mid-span—

$$M_A = M_B = - \int_0^{\frac{l}{2}} \frac{M}{I} dx \div \int_0^{\frac{l}{2}} \frac{dx}{I}$$

the origin being taken at the end or centre, as is most convenient.

*Alternative Form for Graphical Method.*—To put the above equations

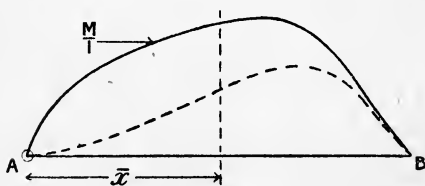
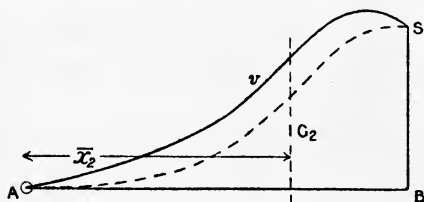
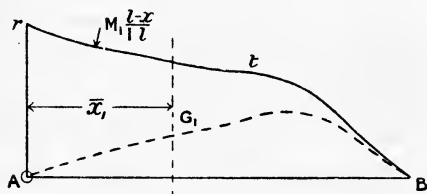
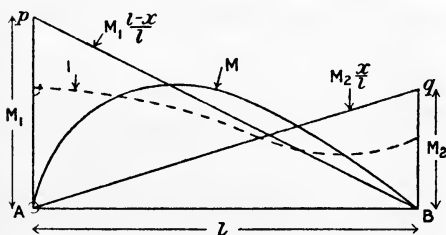

FIG. 131.

(1) and (2) in the form of equations of areas and of moments of areas for graphical solution, it is rather more convenient to proceed as follows. Treat the effect of the two fixing couples separately, adding their effects. In other words, split  $M'$  into two parts, regarding the ordinates of the trapezoid APQB, Fig. 128, as the sum of the vertical ordinates of the two triangles APB and PQB, or APB and AQB, *i.e.* with A as origin at a distance  $x$ —

$$M' = M_A \cdot \frac{l-x}{l} + M_B \cdot \frac{x}{l}$$

$$\text{and } \frac{M'}{I} = M_A \frac{l-x}{I l} + M_B \cdot \frac{x}{I l}$$

Let  $M_A = \alpha \cdot M_1$  and  $M_B = \beta M_2$ , where  $M_1$  and  $M_2$  are any assumed equal or unequal values of the fixing couples. Draw the lines  $pB$  and  $qA$ , which represent  $M_1 \frac{l-x}{l}$  and  $M_2 \frac{x}{l}$  as shown in Fig. 131, and by dividing each ordinate by  $I$ , find the curves  $rtB$  and  $svA$ , or—

$$M_1 \frac{l-x}{I \cdot l} \text{ and } M_2 \frac{x}{I l}$$

as shown in Fig. 131.

Let  $A_1'$  and  $A_2'$  be the areas under the two curves  $\frac{M_1}{I} \cdot \frac{l-x}{l}$  and

$\frac{M_2}{I} \cdot \frac{x}{l}$  respectively, and  $\bar{x}_1$  and  $\bar{x}_2$  be the distances of their respective centroids from the origin A. Let A and  $\bar{x}$  refer to the curve  $\frac{M}{I}$  for a beam simply supported at A and B, then, the change of slope being zero,  $\int_0^l \frac{M + M'}{I} dx = 0$ , or—

$$A + a \cdot A_1' + \beta A_2' = 0 \dots \dots \dots (3)$$

And the change of level being nil—

$$\int_0^l \frac{(M + M')x}{I} dx = 0$$

or,  $A \cdot \bar{x} + aA_1'\bar{x}_1 + \beta A_2'\bar{x}_2 = 0 \dots \dots \dots (4)$

And from the two simultaneous equations (3) and (4),  $a$  and  $\beta$  may be found. The scales will be very simple, that of bending moment being alone important, since  $I$  enters similarly into every term of the equations, and  $a$  and  $\beta$  are mere ratios.

The equation (4) in terms of moments of areas may very conveniently be reduced to one of areas by taking the first derived areas (Art. 68) of each of the three areas under the curves, with the origin A as pole.

If the end slopes are not zero, the right-hand sides of the equations (3) and (4) are the same as those mentioned for (1) and (2).

**89. Continuous Beams. Theorem of Three Moments.**—A beam resting on more than two supports and covering more than one span is called a continuous beam. Beams supported at the ends and propped at some intermediate point have already been noticed (Arts. 78 and 80), and form simple special cases of continuous beams.

Considering first a simple case of a continuous beam, let AB and BC, Fig. 132, be

two consecutive spans of length  $l_1$  and  $l_2$  of a continuous beam, the uniformly spread loads on  $l_1$  and  $l_2$  being  $w_1$  and  $w_2$  per unit length respectively. Then for either span, as in Art. 85, the bending moment is the algebraic sum of the bending moment for a freely supported beam of the same span and that caused by the fixing moments at the supports, or, as in Art. 85 (8)—

$$EI \frac{d^2y}{dx^2} = M + M'$$

$M'$  being generally of opposite sign to  $M$ . First apply this to the span BC, taking B as origin and  $x$  positive to the right,  $M$  being equal

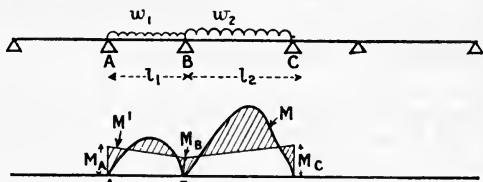

FIG. 132.

to  $-\frac{w_2}{2}(l_2x - x^2)$ , being reckoned negative when producing concavity upwards, by (7) and (8), Art. 85—

$$EI \frac{d^2y}{dx^2} = -\frac{w_2}{2}l_2x + \frac{w_2}{2}x^2 + M_B + (M_C - M_B)\frac{x}{l_2} \quad \dots (1)$$

and integrating—

$$EI \frac{dy}{dx} = -\frac{w_2}{4}l_2x^2 + \frac{w_2}{6}x^3 + M_B \cdot x + (M_C - M_B)\frac{x^2}{2l_2} + EI \cdot i_B \quad (2)$$

where  $i_B$  is the value of  $\frac{dy}{dx}$  at B, where  $x = 0$ .

Integrating again,  $y$  being 0 for  $x = 0$ —

$$EI \cdot y = -\frac{w_2 l_2^2}{12} \cdot x^3 + \frac{w_2}{24} x^4 + \frac{M_B}{2} \cdot x^2 + (M_C - M_B)\frac{x^3}{6l_2} + EI \cdot i_B \cdot x + 0 \quad (3)$$

and when  $x = l_2$ ,  $y = 0$ , hence dividing by  $l_2$ —

$$EI \cdot i_B = \frac{w_2 l_2^3}{24} - \frac{M_B l_2}{2} - \frac{(M_C - M_B)l_2}{6}$$

$$\text{or,} \quad 6EI \cdot i_B = \frac{w_2 l_2^3}{4} - 2M_B l_2 - M_C l_2 \quad \dots \dots \dots (4)$$

Now, taking B as origin, and dealing in the same way with the span BA,  $x$  being positive to the left, we get similarly (changing the sign of  $i_B$ )—

$$-6EI \cdot i_B = \frac{w_1 l_1^3}{4} - 2M_B l_1 - M_A \cdot l_1 \quad \dots \dots (5)$$

and adding (4) and (5)—

$$M_A l_1 + 2M_B(l_1 + l_2) + M_C \cdot l_2 - \frac{1}{4}(w_1 l_1^3 + w_2 l_2^3) = 0 \quad \dots (6)$$

This is Clapeyron's Theorem of Three Moments for the simple loading considered. If there are  $n$  supports and  $n - 1$  spans, or  $n - 2$  pairs of consecutive spans, such as ABC,  $n - 2$  equations, such as (6), may be written down. Two more will be required to find the bending moments at  $n$  supports, and these are supplied by the end conditions of the beam: e.g. if the ends are freely supported, the bending moment at each end is zero.

If an end, say at A, were fixed horizontal,  $i_A = 0$  and an equation similar to (5) for the end span would be

$$2M_A + M_B - \frac{w_1 l_1^2}{4} = 0$$

When the bending moment at each support is known, the reactions at the supports may be found by taking the moments of internal and external forces about the various supports, or from Art. 85 (4), the shearing force just to the right of  $A_1$ ,

$$F_A = \frac{M_B - M_A}{l} - \frac{wl}{2} \text{ being positive downwards}$$

The shearing force immediately to each side of a support being found, the pressure on that support is the algebraic difference of the shearing forces on the two sides. As the shearing force generally changes sign at a support, the magnitude of the reaction is generally the sum of the magnitudes of the shearing forces on either side of the support without regard to algebraic sign.

EXAMPLE 1.—A beam rests on five supports, covering four equal spans, and carries a uniformly spread load. Find the bending moments, reactions, etc., at the supports.

Since the ends are free (Fig. 133),  $M_A = 0$ , and  $M_E = 0$ .

And from the symmetry evidently  $M_D = M_B$ .

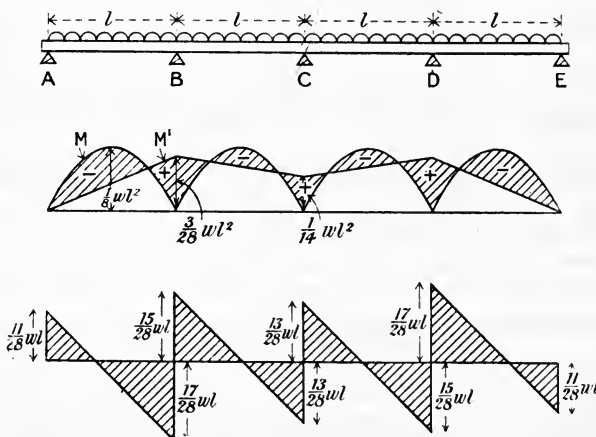

FIG. 133.

Applying the equation of three moments (6) to the portions ABC and BCD—

$$\begin{aligned} 0 + 2M_B \cdot 2l + M_C \cdot l - \frac{1}{2}wl^3 &= 0 \\ \text{and } M_B \cdot l + 2M_C \cdot 2l + M_B l - \frac{1}{2}wl^3 &= 0 \\ \text{hence } 4M_B l + M_C l - \frac{1}{2}wl^3 &= 0 \\ \text{and } 4M_B l + 8M_C l - wl^3 &= 0 \\ 7M_C \cdot l = \frac{1}{2}wl^3 & \quad M_C = \frac{1}{14}wl^2 \quad M_B = \frac{3}{28}wl^2 = M_D \end{aligned}$$

Taking moments about B—

$$-R_A \cdot l + \frac{wl^2}{2} = \frac{3}{28}wl^2 \quad R_A = \frac{11}{28}wl = R_E$$

Taking moments about C—

$$\begin{aligned} \frac{22}{28}wl^2 + R_B \cdot l - 2wl^2 &= -\frac{1}{14}wl^2 \quad R_B = \frac{8}{7}wl = R_D \\ R_C = 4wl - \frac{11}{14}wl - \frac{1}{7}wl &= \frac{13}{14}wl \end{aligned}$$

The shearing-force diagram for Fig. 133 may easily be drawn by setting up  $\frac{11}{28}wl$  at A, and decreasing the ordinates uniformly by an

amount  $wl$  to  $-\frac{17}{28}wl$  at B, increasing there by  $\frac{8}{7}wl$ , and so on, changing at a uniform rate over each span, and by the amount of the reactions at the various supports.

The bending-moment diagram (Fig. 133) may conveniently be drawn by drawing parabolas of maximum ordinate  $\frac{1}{8}wl^2$  on each span, and erecting ordinates  $M_B, M_C, M_D$ , and joining by straight lines. The algebraic sum of  $M$  and  $M'$  is given by vertical ordinates across the shaded area in Fig. 133. An algebraic expression for the bending moment in any span may be written from (8) Art. 85 as follows (positive for convexity upwards):—

Span AB, origin A—

$$M = -\frac{w}{2}(lx - x^2) + \frac{3}{28}wlx = -\frac{wx}{2}\left(\frac{11}{14}l - x\right)$$

Span BC, origin B—

$$M = -\frac{w}{2}(lx - x^2) + \frac{3}{28}wl^2 - \frac{1}{28}wlx = -\frac{w}{2}\left(\frac{15}{14}lx - \frac{3}{14}l^2 - x^2\right)$$

EXAMPLE 2.—A continuous girder ABCD covers three spans, AB 60 feet, BC 100 feet, CD 40 feet. The uniformly spread loads are 1 ton, 2 tons, and 3 tons per foot-run on AB, BC, and CD respectively. If the girder is of the same cross-section throughout, find the bending moments at the supports B and C, and the pressures on each support.

For the spans ABC—

$$0 + 320M_B + 100M_C = \frac{1}{4} \times 1000(216 + 2000) = 554,000$$

hence  $16M_B + 5M_C = 27,700$  tons-feet.

For the spans BCD—

$$100M_B + 280M_C + 0 = \frac{1}{4} \times 1000(2000 + 192)$$

hence  $5M_B + 14M_C = 27,400$  ton-feet.

From which  $M_B = 1260.3$  ton-feet  $M_C = 1507.0$  ton feet.

Taking moments about B,  $R_A \times 60 - 60 \times 30 = -1260.3$

$$R_A = 9 \text{ tons}$$

“ “  $C, 9 \times 160 + 100R_B - 60 \times 130 - 200 \times 50 = -1507$

$$R_B = 148.5 \text{ tons}$$

“ “  $C, 40R_D - 120 \times 20 = -1507$

$$R_D = 22.3 \text{ tons}$$

“ “  $B, 22.3 \times 140 + 100R_C - 120 \times 120 - 200 \times 50 = -1260$

$$R_C = 200.1 \text{ tons}$$

90. Continuous Beams; any Loading.—Let the diagrams of bending moment APB and BQC be drawn for any two consecutive spans AB or  $l_1$ , and BC or  $l_2$  (Fig. 134), of a continuous beam as if each span were bridged by independent beams freely supported at their ends. Let the area APB be  $A_1$ , and the distance of its centroid from the point A be  $\bar{x}_1$ , so that  $A_1\bar{x}_1$  is the moment of the area about the point A. Let the area under BQC be  $A_2$ , and the distance of its centroid from



C be  $\bar{x}_2$ , the moment about C being  $A_2\bar{x}_2$ . (In accordance with the signs adopted in Art. 77, and used subsequently, the areas  $A_1$  and  $A_2$  will be negative quantities for downward loading, bending moments which produce upward convexity being reckoned positive.) Draw the trapezoids ARSB and BSTC as in Art. 85, to represent  $M'$ , the bending moments due to the fixing couples. Let  $A_1'$  and  $A_2'$  be the areas of

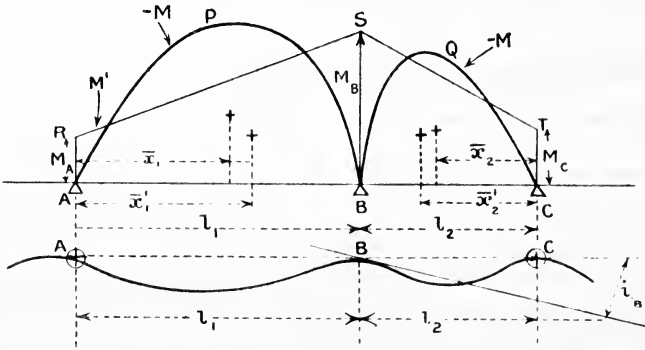

FIG. 134.

ARSB and BSTC respectively, and  $\bar{x}_1'$  and  $\bar{x}_2'$  the distances of their centroids from A and C respectively.

From A as origin,  $x$  being measured positive towards B, using the method of Art. 81 equation (3) between limits  $x = l_1$  and  $x = 0$ , the supports at A and B being at the same level—

$$\left(x \frac{dy}{dx} - y\right)_0^{l_1} = l_1 i_B = \frac{I}{EI} \int_0^{l_1} (M + M') x dx = \frac{I}{EI} (A_1 \bar{x}_1 + A_1' \bar{x}_1') \quad (1)$$

$i_B$  being the slope  $\left(\frac{dy}{dx}\right)$  at B.

From C as origin,  $x$  being measured positive toward B, C and B being at the same level—

$$\left(x \frac{dy}{dx} - y\right)_0^{l_2} = l_2 i_B = \frac{I}{EI} (A_2 \bar{x}_2 + A_2' \bar{x}_2') \dots \dots (2)$$

Equating the slope at B from (1) and (2) with sign reversed on account of the reversed direction of  $x$ —

$$\frac{A_1 \bar{x}_1 + A_1' \bar{x}_1'}{l_1} = -\frac{A_2 \bar{x}_2 + A_2' \bar{x}_2'}{l_2} \dots \dots (3)$$

And as in Art. 87 (4a), by joining AS and taking moments about A—

$$A_1' \bar{x}_1' = \frac{l_1^2}{6} (M_A + 2M_B)$$

and similarly

$$A_2' \bar{x}_2' = \frac{l_2^2}{6} (M_C + 2M_B)$$

hence (3) becomes—

$$\frac{A_1 \bar{x}_1}{l_1} + \frac{A_2 \bar{x}_2}{l_2} + \frac{1}{6} M_A \cdot l_1 + \frac{1}{3} M_B (l_1 + l_2) + \frac{1}{6} M_C l_2 = 0$$

or,

$$\frac{6A_1 \bar{x}_1}{l_1} + \frac{6A_2 \bar{x}_2}{l_2} + M_A \cdot l_1 + 2M_B (l_1 + l_2) + M_C l_2 = 0 \quad (4)$$

This is a general form of the Equation of Three Moments, of which equation (6) of the previous article is a particular case easily derived by writing  $A_1 = -\frac{2}{3} \cdot \frac{wl_1^2}{8} \cdot l_1$ , and  $\bar{x}_1 = \frac{l_1}{2}$ , etc., the areas  $A_1$  and  $A_2$  being negative for bending producing concavity upwards. For a beam on  $n$  supports this relation (4) provides  $n - 2$  equations, and the other necessary two follow from the manner of support at the ends. If either end is fixed horizontally, an equation of moments for the adjacent span follows from the method of Art. 87. If A is an end fixed horizontally, and AB the first span, from area moments *about B*, an equation similar to (5), Art. 87, is—

$$2M_A + M_B + \frac{6A_1(l_1 - \bar{x}_1)}{l_1^2} = 0 \quad (A_1 \text{ being generally negative})$$

If both ends are fixed horizontally, a similar equation holds for the other end. If, say, the end A is fixed at a downward slope  $i_A$  towards B, the right-hand side of this equation would be  $-\frac{6EIi_A}{l_1}$  instead of zero. If either end overhangs an extreme support the bending moment at the support is found as for a cantilever.

If some or all the supports sink, the support B falling  $\delta_1$  below A and  $\delta_2$  below C, a term corresponding to  $y$  appears in (1) and (2), so that (3) becomes—

$$\frac{A_1 \bar{x}_1 + A_1' \bar{x}_1' + EI\delta_1}{l_1} = -\frac{A_2 \bar{x}_2 + A_2' \bar{x}_2' + EI\delta_2}{l_2} \quad (3a)$$

and (4) becomes—

$$\frac{6A_1 \bar{x}_1}{l_1} + \frac{6A_2 \bar{x}_2}{l_2} + M_A \cdot l_1 + 2M_B (l_1 + l_2) + M_C \cdot l_2 + 6EI \left( \frac{\delta_1}{l_1} + \frac{\delta_2}{l_2} \right) = 0 \quad (5)$$

*Wilson's Method.*—A simple and ingenious method of solving general problems on continuous beams, published by the late Dr. George Wilson,<sup>1</sup> consists of finding the reactions at the supports by equating the upward deflections caused at every support by all the supporting forces, to the downward deflections which the load would cause at those various points if the beam were supported at the ends only. This provides sufficient equations to determine the reactions at all the supports except the end ones. The end reactions are then found by the usual method of taking moments of all upward and downward forces about one end, and in the case of free ends, equating the algebraic sum to

<sup>1</sup> *Proc. Roy. Soc.*, vol. 62, Nov., 1897.

zero. To take a definite case, suppose the beam to be supported at five points A, B, C, D, and E, Fig. 135, all at the same level. Let the distances of B, C, D, and E from A be  $b$ ,  $c$ ,  $d$ , and  $e$  respectively. Let the deflections at A, B, C, D, and E due to the load on the beam if simply supported at A and E be  $y_A, y_B, y_C, y_D,$  and  $y_E$  respectively. These may be calculated by the methods of Arts. 78, 80, 81, or 82, according to the manner in which the beam is loaded.

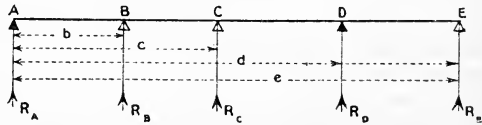

FIG. 135.

Now let the upward deflection at B, C, and D, if the beam were supported at the ends, due to 1 lb. or 1 ton or other unit force at B be—

$${}_b\delta_B, {}_b\delta_C, \text{ and } {}_b\delta_D \text{ respectively,}$$

and those at B, C, and D due to unit force at C be—

$${}_c\delta_B, {}_c\delta_C, \text{ and } {}_c\delta_D \text{ respectively,}$$

and due to unit force at D be—

$${}_d\delta_B, {}_d\delta_C, \text{ and } {}_d\delta_D \text{ respectively.}$$

Then all the supports being at zero level, if  $R_B, R_C,$  and  $R_D$  are the reactions at B, C, and D respectively, equating downward and upward deflections at B, C, and D for the beam supported at the ends A and E only—

$$y_B = (R_B \times {}_b\delta_B) + (R_C \times {}_c\delta_B) + (R_D \times {}_d\delta_B) \dots (6)$$

$$y_C = (R_B \times {}_b\delta_C) + (R_C \times {}_c\delta_C) + (R_D \times {}_d\delta_C) \dots (7)$$

$$y_D = (R_B \times {}_b\delta_D) + (R_C \times {}_c\delta_D) + (R_D \times {}_d\delta_D) \dots (8)$$

Note that  ${}_c\delta_B = {}_b\delta_C, {}_d\delta_B = {}_b\delta_D, {}_c\delta_C = {}_d\delta_C,$  which becomes apparent by changing  $b$  into  $x, x$  into  $b,$  and  $a$  into  $a + b - x$  in (7), Art. 80.

From the three simple simultaneous equations, (6), (7), and (8),  $R_B, R_C,$  and  $R_D$  can be determined.  $R_E$  may be found by an equation of moments about A.

$$R_E \times e = (\text{moment of whole load about A}) - b \cdot R_B - cR_C - dR_D$$

and  $R_A = \text{whole load} - R_B - R_C - R_D - R_E$

The exercise at the end of Art. 80 is a simple example of this method, there being only one support, and therefore only one simple equation for solution.

Wilson's method may be used for algebraic calculations when the loading is simple, so that the upward and downward deflections may be easily calculated, but it is equally applicable to irregular types of loading where the downward deflections at several points are all determined in one operation graphically.

When the reactions are all known, the bending moment and shearing force anywhere can be obtained by direct calculation from the definitions (Art 56).

Sinking of any support can evidently be taken into account in this method very simply. If the support at B, for example, sinks a given amount, that amount of subsidence must be subtracted from the left-hand side of equation (6).

If one end of the beam is fixed, the deflections must be calculated as for a propped cantilever (Arts. 79 and 81). If both ends, they must be calculated as indicated in Arts. 86 and 87.

EXAMPLE 1.—Find the reactions in Ex. 1 of Art. 89 by Wilson's Method. Using Fig. 133, the beam being supported at A and E only, and A being the origin, by (9) Art. 78.

$$y_B = \frac{wl^4}{24EI}(1 - 8 + 64) = \frac{57wl^4}{24EI} = y_D \text{ from the symmetry}$$

And by (11), Art 78—

$$y_C = \frac{5}{384} \cdot \frac{256l^4}{EI} = \frac{10}{3} \frac{wl^4}{EI}$$

And using (7) and (8), Art. 80, the upward deflections due to the props are, at B—

$$\begin{aligned} \frac{l^3}{EI} \left\{ \frac{R_B \times 9 \times 1}{3 \times 4} - \frac{R_C \times 2}{4} \left( \frac{1}{6} - \frac{4}{6} - \frac{4}{3} \right) - \frac{R_D}{4} \left( \frac{1}{6} - \frac{9}{6} - \frac{3}{3} \right) \right\} \\ = \frac{l^3}{EI} \left( \frac{4}{3}R_B + \frac{11}{12}R_C \right), \text{ since by symmetry } R_B = R_D \end{aligned}$$

And at C—

$$\frac{l^3}{EI} \left\{ -\frac{2R_B \cdot 2}{4} \left( \frac{4}{3} - \frac{9}{6} - \frac{3}{3} \right) + \frac{R_C \cdot 16}{12} \right\} = \frac{l^3}{EI} \left( \frac{11}{6}R_B + \frac{4}{3}R_C \right)$$

Equating upward and downward deflections at B and C—

$$\begin{aligned} \frac{57}{24}wl &= \frac{4}{3}R_B + \frac{11}{12}R_C \\ \frac{10}{3}wl &= \frac{11}{6}R_B + \frac{4}{3}R_C \end{aligned}$$

from which  $R_B = R_D = \frac{8}{7}wl$  and  $R_C = \frac{13}{14}wl$ .

$$R_A = R_E = \frac{1}{2}(4wl - 2 \times \frac{8}{7}wl - \frac{13}{14}wl) = \frac{11}{28}wl$$

$$M_B = -\frac{11}{28}wl^2 + \frac{wl^2}{2} = \frac{3}{28}wl^2$$

$$M_C = 2wl^2 - \frac{8}{7}wl^2 - \frac{11}{28}wl \times 2l = \frac{1}{14}wl^2$$

The bending moment anywhere can be simply stated, the diagrams of bending moment and shearing being as shown in Fig. 133.

EXAMPLE 2.—A continuous beam 30 feet long is carried on supports at its ends, and is propped to the same level at points 10 feet and 22 feet from the left-hand end. It carries loads of 5 tons, 7 tons, and 6 tons at distances of 7 feet, 14 feet, and 24 feet respectively from the left-hand end. Find the bending moment at the props; the reactions at the four supports, and the points of contraflexure.

Firstly, by the General Equation of Three Moments.—For the spans ABC, Fig. 136, with the notation of Art. 90.

Moment of the bending-moment diagram area on AB about A—

$$A_1\bar{x}_1 = \left(\frac{1}{2} \cdot 7 \cdot \frac{21}{2} \cdot \frac{2}{3} \cdot 7\right) + \left(\frac{1}{2} \cdot 3 \cdot \frac{21}{2} \cdot 8\right) = \frac{343}{2} + 126 = 297\frac{1}{2} \text{ ton-(feet)}^3$$

Moment of the bending-moment diagram area on BC about C—

$$A_2\bar{x}_2 = \left(\frac{1}{2} \cdot 4 \cdot \frac{56}{3} \cdot \frac{2}{3}\right) + \left(\frac{1}{2} \cdot 8 \cdot \frac{56}{3} \cdot \frac{16}{3}\right) = \frac{3136}{9} + \frac{3584}{9} = 746\frac{2}{3} \text{ ton-(feet)}^3$$

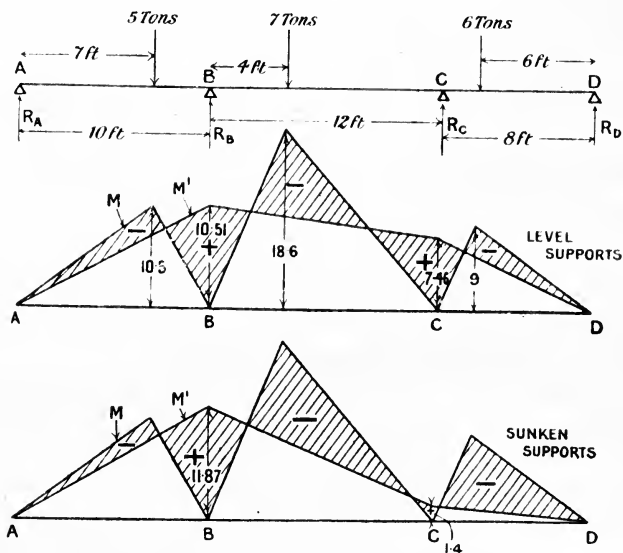

FIG. 136.

This must be taken as negative in accordance with the signs adopted at the end of Art. 77. Then from (4) of Art. 90, since  $M_A = 0$ —

$$-(6 \times 297\frac{1}{2}) - \frac{6 \times 746\frac{2}{3}}{12} + 0 + 2M_B \times 22 + 12M_C = 0$$

or  $44M_B + 12M_C = 551\cdot83 \dots \dots \dots (9)$

For the spans BCD—

About B,  $A_1\bar{x}_1 = \left(\frac{1}{2} \cdot 4 \cdot \frac{56}{3} \cdot \frac{2}{3} \cdot 4\right) + \left(\frac{1}{2} \cdot 8 \cdot \frac{56}{3} \cdot \frac{20}{3}\right) = 597\frac{1}{3}$   
 About D,  $A_2\bar{x}_2 = \left(\frac{1}{2} \cdot 2 \cdot 9 \cdot \frac{20}{3}\right) + \left(\frac{1}{2} \cdot 6 \cdot 9 \cdot 4\right) = 168$

Taking these as negative, from (4),  $M_D$  being 0—

$$-\frac{6 \times 597\frac{1}{3}}{12} - \frac{6 \times 168}{8} + 12M_B + 2M_C \times 20 + 0 = 0$$

or,  $12M_B + 40M_C = 424\frac{2}{3} \dots \dots \dots (10)$

And from the equations (9) and (10)

$$M_B = 10\frac{1}{2} \text{ ton-feet} \qquad M_C = 7\cdot46 \text{ ton-feet}$$

Taking moments to the left of B—

$$5 \times 3 - 10R_A = 10 \cdot 51 \quad R_A = 0 \cdot 449 \text{ ton}$$

Taking moments to left of C—

$$5 \times 15 + 7 \times 8 - 22 \times 0 \cdot 45 - 12R_B = 7 \cdot 46 \quad R_B = 9 \cdot 471 \text{ ton}$$

Taking moments to right of C—

$$6 \times 2 - 8R_D = 7 \cdot 46 \quad R_D = 0 \cdot 567 \text{ ton}$$

$$R_C = 5 + 7 + 6 - 0 \cdot 45 - 9 \cdot 47 - 0 \cdot 57 = 7 \cdot 51 \text{ tons}$$

*Inflections.*—Taking A as origin and taking convexity upward as positive bending. From 5 ton load to B—

bending moment =  $5(x-7) - 0 \cdot 449x = 4 \cdot 551x - 35$ , which vanishes, for  $x = 7 \cdot 9$  feet.

From B to 7 ton load, bending moment is—

$4 \cdot 551x - 35 - 9 \cdot 471(x - 10) = 59 \cdot 71 - 4 \cdot 92x$ , which vanishes, for  $x = 12 \cdot 14$  feet.

From 7 ton load to C the bending moment is—

$59 \cdot 71 - 4 \cdot 92x + 7(x - 14) = 2 \cdot 08x - 38 \cdot 29$ , which vanishes, for  $x = 18 \cdot 5$  feet.

From C to 6 ton load the bending moment is—

$2 \cdot 08x - 38 \cdot 29 - 7 \cdot 51(x - 22) = 126 \cdot 9 - 5 \cdot 43x$ , which vanishes, for  $x = 23 \cdot 4$  feet.

*Secondly, by Wilson's Method.*—With end supports only, the downward deflections, by (7) and (10) of Art. 80, are, at B—

$$-\frac{1}{6EI} \times \frac{1}{30} \{ \{ 5 \times 7 \times 20(400 - 529 - 322) \} + \{ 7 \times 16 \times 10(100 - 448 - 196) \} + \{ 6 \times 6 \times 10(100 - 576 - 288) \} \}$$

$$\text{or } y_B = \frac{1}{180EI} (315,700 + 609,280 + 275,040) = \frac{1,200,020}{180EI}$$

$$y_C = -\frac{1}{6EI} \times \frac{1}{30} \{ \{ 5 \times 7 \times 8(64 - 529 - 322) \} + \{ 7 \times 14 \times 18(64 - 256 - 448) \} + \{ 6 \times 6 \times 22(484 - 576 - 288) \} \}$$

$$\text{or } y_C = \frac{1}{180EI} (220,360 + 501,760 + 300,960) = \frac{1,023,080}{180EI}$$

With end supports only, the upward deflections caused by the props at B and C are—

$$\text{At B } \frac{1}{6EI} \times \frac{1}{30} \{ \{ 2R_B \times 100 \times 400 \} + \{ -R_C \times 8 \times 10(100 - 484 - 352) \} \}$$

$$= \frac{1}{180EI} (80,000R_B + 58,880R_C)$$

$$\begin{aligned} \text{At C, } \frac{1}{6EI \cdot 30} [(-R_B \times 10 \times 8(64 - 400 - 400)) + (2R_C \times 64 \times 484)] \\ = \frac{1}{180EI} (58,880R_B + 61,952R_C) \end{aligned}$$

Equating the upward and downward deflections at B and C—

$$80,000R_B + 58,880R_C = 1,200,020 \quad \dots \quad (11)$$

$$58,880R_B + 61,952R_C = 1,023,080 \quad \dots \quad (12)$$

which equations give the values—

$$R_B = 9.47 \text{ tons} \quad R_C = 7.51 \text{ tons}$$

confirming the previous results. The reactions at the ends, bending moments at the supports, and position of the points of inflection follow by direct calculation very simply (see Fig. 136).

EXAMPLE 3.—If the cross-section of the continuous beam in Example 2 above has a moment of inertia of 300 inch units, and the support B sinks  $\frac{1}{20}$  inch and the support C sinks  $\frac{1}{10}$  inch, find the bending moments and reactions at the supports, E being 13,000 tons per square inch.

Firstly, by *Wilson's Method*.—The downward deflection at B due to the load would be—

$$\frac{1}{EI} \left( \frac{1,200,020}{180} \right) \text{ feet} \quad \text{or} \quad \frac{\text{ton} \cdot (\text{feet})^3}{\text{ton} \cdot (\text{feet})^3}$$

if E and I are in foot and ton units. If E and I are in inch units the deflection at B would be—

$$\frac{1728}{EI} \times \frac{1,200,020}{180} \text{ inches, the dimensions being } \frac{\text{ton} \cdot (\text{inches})^3}{\text{ton} \cdot (\text{inches})^3}$$

The upward deflection at B due to the props has to balance 0.05 inch less than this amount, hence—

$$\frac{1728}{180EI} (80,000R_B + 58,880R_C) = \frac{1728}{180EI} (1,200,020) - 0.05$$

or corresponding to (11), putting I = 300 and E = 13,000—

$$80,000R_B + 58,880R_C = 1,200,020 - 20,312 = 1,179,708 \quad (13)$$

and corresponding to (12) with 0.1 inch subsidence at C—

$$58,880R_B + 61,952R_C = 1,023,080 - 40,625 = 982,455 \quad (14)$$

From the simple equations (13) and (14)—

$$R_C = 6.13 \text{ tons} \quad R_B = 10.23 \text{ tons}$$

And by an equation of moments about A,  $R_D = 1.33 \text{ tons}$ ,  
and by an equation of moments about D,  $R_A = 0.31 \text{ ton}$ .

Secondly, by the General Equation of Three Moments.—From equation (5), Art. 90, an equation corresponding to equation (9), the units of which are ton-(feet)<sup>2</sup>, may be formed. Using inch units, this becomes—

$$144(44M_B + 12M_C) + 6 \times 13,000 \times 300 \left( \frac{0.05}{120} - \frac{0.05}{144} \right) = 551.83 \times 144$$

or,

$$44M_B + 12M_C = 551.83 - 11.3 \dots (15)$$

And corresponding to (10)—

$$12M_B + 40M_C = 424.6 - \frac{6 \times 13,000 \times 300 \left( \frac{0.05}{144} + \frac{0.1}{96} \right)}{144}$$

or,

$$12M_B + 40M_C = 199 \dots (16)$$

And from (15) and (16)—

$$M_B = 11.87 \text{ ton-feet} \quad M_C = 1.404 \text{ ton-feet}$$

From an equation of moments to the left of B,  $R_A = 0.31$  ton  
 " " " " right of C,  $R_D = 1.33$  tons  
 " " " " right of B,  $R_C = 6.13$  "  
 " " " " left of C,  $R_B = 10.23$  "

confirming the previous results.

The diagram of bending moments is shown in the lower part of Fig. 136. The serious changes in the magnitude of the bending moments at B, C, and under the 6-ton load may be noted; also the change in position of the points of inflection to the right and left of C, involving change in signs of the bending moment over some length of the beam: all these changes arise from the slight subsidence of the two supports at B and C.

91. Continuous Beams of Varying Section.—The methods of the previous article may be applied to cases where the moment of inertia of cross-section ( $I$ ) varies along the length of span. The modifications in the first method will be as follow. Equation (1), Art. 90, becomes—

$$k_B = \frac{1}{E} \int_0^{l_1} \frac{M + M'}{I} \cdot x dx = \frac{1}{E} (A_1 \bar{x}_1 + A_1' \bar{x}_1') \dots (1)$$

where  $A_1$  and  $\bar{x}_1$ , etc., refer to areas of the curves  $\frac{M}{I}$ , etc.

With such modified meanings for the symbols equation (3), Art. 90, holds good, but it may also be written in integral form thus—

$$\frac{1}{l_1} \left( \int_0^{l_1} \frac{Mx}{I} dx + \int_0^{l_1} \frac{M'x}{I} dx \right) = -\frac{1}{l_2} \left( \int_0^{l_2} \frac{Mx}{I} dx + \int_0^{l_2} \frac{M'x}{I} dx \right) (2)$$

the origins being A for the left side and C for the right side.



For the left side—

$$M' = M_A + \frac{x}{l_1}(M_B - M_A)$$

$x$  measured positive towards B, and for the right side—

$$M' = M_C + \frac{x}{l_2}(M_B - M_C)$$

$x$  measured positive towards B; hence (2) may be written—

$$\begin{aligned} \frac{I}{l_1} \left\{ \int_0^{l_1} \frac{Mx}{I} dx + M_A \int_0^{l_1} \frac{x}{I} dx + \frac{M_B - M_A}{l_1} \int_0^{l_1} \frac{x^2}{I} dx \right\} \\ = -\frac{I}{l_2} \left\{ \int_0^{l_2} \frac{Mx}{I} dx + M_C \int_0^{l_2} \frac{x}{I} dx + \frac{M_B - M_C}{l_2} \int_0^{l_2} \frac{x^2}{I} dx \right\} \quad (3) \end{aligned}$$

If  $M$  and  $I$  can be expressed as simple functions of  $x$  (from either origin) the above integrals can usually be found without much trouble, and (3) becomes a simple equation with two unknown quantities,  $M_A$  and  $M_B$ . For a beam on  $n$  supports, this relation (3) provides  $n - 2$  equations, and the other two necessary for the  $n$  unknown bending moments at the  $n$  supports follow as before from the fixing conditions at the ends.

If the quantities  $\frac{Mx}{I}$ ,  $\frac{x}{I}$ ,  $\frac{x^2}{I}$ , etc., are not simple and convenient to integrate, the integrals may be found graphically by plotting the curves

as in Art. 88. Note that  $\frac{I}{l_1} \int_0^{l_1} \frac{Mx}{I} dx$  is represented by the area of a

figure derived, as in Art. 68, from the curve  $\frac{M}{I}$ , with A as pole, and similarly with other curves.

*Alternative Form for Graphical Method.*—We may state the above equations in a convenient form for graphical solution, as in Art. 88, by treating separately the effect of the moments at each support on the two adjacent spans. This is equivalent to regarding the trapezoid ARSB, Fig. 134, as the sum of two triangles ARB and ASB, and, similarly, with BSTC, or with origin A—

$$M' = \frac{l_1 - x}{l_1} \cdot M_A + \frac{x}{l_1} M_B$$

$$\frac{M'}{I} = \frac{l_1 - x}{l_1 I} \cdot M_A + \frac{x}{l_1 I} \cdot M_B$$

and with origin C—

$$M' = \frac{l_2 - x}{l_2} \cdot M_C + \frac{x}{l_2} \cdot M_B$$

$$\frac{M'}{I} = \frac{l_2 - x}{l_2 I} \cdot M_C + \frac{x}{l_2 I} \cdot M_B$$

$$\begin{aligned} \text{Let } M_A &= \alpha M_1 \\ M_B &= \beta M_0 \\ M_C &= \gamma M_2 \end{aligned}$$

where  $M_1$ ,  $M_0$ , and  $M_2$  are any assumed equal or unequal values of the

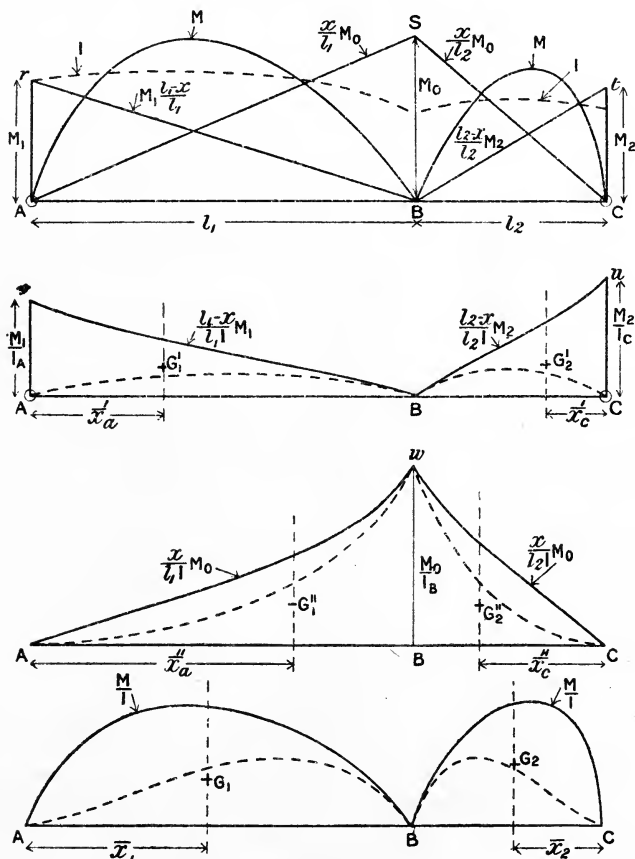

FIG. 137.

bending moments at A, B, and C respectively. Draw the lines AS and Br (Fig. 137), the ordinates of which represent  $\frac{x}{l_1} M_0$  and  $\frac{l_1 - x}{l_1} \cdot M_1$  with A as origin. Also draw the lines CS and B'l', which represent  $\frac{x}{l_2} M_0$  and  $\frac{l_2 - x}{l_2} \cdot M_2$  with C as origin.

Divide the ordinates of these four curves by the variable values

of I, and so get the curves  $Aw$  and  $Bv$ ,  $Cw$  and  $Bu$ , as shown in Fig. 137. Let  $a'$  and  $a''$  be the areas under the curves  $AvB$  and  $AwB$  respectively, and let  $\bar{x}_a'$  and  $\bar{x}_a''$  be the respective horizontal distances of their centroids from A. Let  $A_1$  be the area under the curve  $\frac{M}{I}$  on the span AB and  $\bar{x}_1$ , the horizontal distance of its centroid from A.

Let  $c'$  and  $c''$  be the areas under the curves  $CuB$  and  $CwB$ ,  $\bar{x}_c'$  and  $\bar{x}_c''$ , the horizontal distances of their centroids from C,  $A_2$  being the area under the  $\frac{M}{I}$  curve on the span BC, and  $\bar{x}_2$  the horizontal distance of its centroid from C.

Then, corresponding to (3), Art. 90, we have—

$$\frac{A_1\bar{x}_1 + a'\bar{x}_a' + \beta a''\bar{x}_a''}{l_1} = -\frac{A_2\bar{x}_2 + \gamma c'\bar{x}_c' + \beta c''\bar{x}_c''}{l_2} \quad \cdot \quad (4)$$

This is a form of the equation of three moments in which the unknown quantities are  $\alpha$ ,  $\beta$ , and  $\gamma$ , and the requisite number of equations follows from the consecutive pairs of spans and the conditions of support at the ends just as in the previous cases.

The equation (4) may very conveniently be reduced to an equation of areas by taking the "first derived areas" (see Art. 68) of the areas under the six curves, the pole being at A for those on the span AB, and at C for those on the span BC (see dotted curves, Fig. 137). Sinking of the supports may readily be taken account of in this method, as in Art. 90, by using terms  $E \cdot \delta_1$  and  $E \cdot \delta_2$  in the above equation (4) in place of  $EI\delta_1$  and  $EI\delta_2$  in equation (3a) of Art. 90.

Fixing of the girder ends at any inclination may also be taken into account as indicated in Art. 90, at the end of Art. 87, and at the end of Art. 88.

*Wilson's Method* of solving problems in continuous beams by equating the downward deflections produced by the load to the upward deflections produced by the supporting forces, supposing the beam to be supported at the ends only, may be applied in cases where the value of I varies, provided the deflections for the necessary equations are determined in accordance with the principles in Art. 83. Generally, a graphical method will be the simplest for determining the deflections. Full details of a numerical example will be found in Dr. Wilson's paper already referred to, where the deflections are found by a novel graphical method.

**92. Advantages and Disadvantages of Continuous Beams.**—An examination of Figs. 133 and 136, and other diagrams of bending moment for continuous girders which the reader may sketch, shows that generally (1) the greatest bending moment to which the beam is subjected is less than that for the same spans if the beam were cut at the supports into separate pieces; (2) disregarding algebraic sign, the average bending moment throughout is smaller for the continuous beam, and less material to resist bending is therefore required; (3) in the

continuous beam the bending moment due to external load is not greatest at points remote from the supports, but at the supports; hence, in girders of variable cross-section the heavy sections are not placed in positions where their effect in producing bending stress is greatest.

On the other hand, a small subsidence of one or more supports may cause serious changes in the bending moment and bending stresses at particular sections, as well as changes of sign in bending moment and bending stresses over considerable lengths, with change in position of the points of contraflexure. These changes, resulting from very small changes in level of a support, form serious objections to the use of continuous girders. Another practical objection in the case of built-up girders is the difficulty in attaining the conditions of continuity during construction or renewal, or of determining to what degree the conditions are attained. In a loaded continuous girder two points of contraflexure usually occur between two consecutive supports; if at these two points the girder is hinged instead of being continuous, the bending moment there remains zero, and changes in load or subsidence of a support do not produce changes in sign of the bending moment and bending stresses. This is the principle of the cantilever bridge:<sup>1</sup> the portions between the hinges are under the conditions of a beam simply supported at its ends, and the portions adjoining the piers are practically cantilevers which carry the simply supported beams at their ends. The points of zero bending moment being fixed, the bending moment diagrams become very simple.

#### EXAMPLES VII.

1. A beam is firmly built in at each end and carries a load of 12 tons uniformly distributed over a span of 20 feet. If the moment of inertia of the section is 220 inch units and the depth 12 inches, find the maximum intensity of bending stress and the deflection. ( $E = 13,000$  tons per square inch.)

2. A built-in beam carries a distributed load which varies uniformly from nothing at one end to a maximum  $w$  per unit length at the other. Find the bending moment and supporting forces at each end and the position where maximum deflection occurs.

3. A built-in beam of span  $l$  carries two loads each  $W$  units placed  $\frac{1}{3}l$  from either support. Find the bending moment at the supports and centre, the deflection at the centre and under the loads, and find the points of contraflexure.

4. A built-in beam of span  $l$  carries a load  $W$  at a distance  $\frac{1}{3}l$  from one end. Find the bending moment and reactions at the supports, the deflection at the centre and under the load, the position and amount of the maximum deflection, and the position of the points of contrary flexure.

5. A built-in beam of 20-feet span carries two loads, each 5 tons, placed 5 feet and 13 feet from the left-hand support. Find the bending moments at the supports.

6. A built-in beam of span  $l$  carries a uniformly distributed load  $w$  per unit of length over half the span. Find the bending moment at each

<sup>1</sup> See the author's "Theory of Structures."

support, the points of inflection, the position and magnitude of the maximum deflection.

7. The moment of inertia of cross-section of a beam built in at the ends varies uniformly from  $I_0$  at the centre to  $\frac{1}{2}I_0$  at each end. Find the bending moment at the end and middle, and the central deflection when a load  $W$  is supported at the middle of the span.

8. Solve the previous problem when the load  $W$  is uniformly distributed over the span.

9. A continuous beam rests on supports at its ends and two other supports on the same level as the ends. The supports divide the length into three equal spans each of length  $l$ . If the beam carries a uniformly spread load  $W$  per unit length, find the bending moments and reactions at the supports.

10. A continuous beam covers three consecutive spans of 30 feet, 40 feet, and 20 feet, and carries loads of 2, 1, and 3 tons per foot run respectively on the three spans. Find the bending moment and pressure at each support. Sketch the diagrams of bending moment and shearing force.

11. A continuous beam ABCD 20 feet long rests on supports A, B, C, and D, all on the same level,  $AB = 8$  feet,  $BC = 7$  feet,  $CD = 5$  feet. It carries loads of 7, 6, and 8 tons at distances 3, 11, and 18 feet respectively from A. Find the bending moment at B and C, and the reactions at A, B, C, and D. Sketch the bending-moment diagram. (The results should be checked by using both methods given in Art. 90.)

12. Solve problem No. 9, (a) if one end of the beam is firmly built in, (b) if both ends are built in.

13. Solve problem No. 11, the end A being fixed horizontally.

14. Solve problem No. 11, if the support B sinks  $\frac{1}{10}$  inch, I being 90 (inches)<sup>4</sup> and  $E = 13,000$  tons per square inch.

## CHAPTER VIII.

### SECONDARY EFFECTS OF BENDING.

**93. Resilience of Beams.**—When a beam is bent within the elastic limits, the material is subjected to varying degrees of tensile and compressive bending stress, and therefore possesses elastic strain energy (Art. 41), *i.e.* it is a spring, although it may be a stiff one. The total flexural resilience (see Art. 42) may be calculated in various ways; it may conveniently be expressed in the form—

$$c \times \frac{p^2}{E} \times \text{volume of the material of the beam} \quad \dots (1)$$

where  $p$  is the maximum intensity of direct stress to which the beam is subjected anywhere, and  $c$  is a coefficient depending upon the manner in which the beam is loaded and supported, but which is always less than the value  $\frac{1}{2}$ , which is the constant for uniformly distributed stress (see Art. 42). If  $f$  is the intensity of stress at the elastic limit of the material, then—

$$c \times \frac{f^2}{E} \times \text{volume}$$

is the proof resilience of the beam.

For a beam of any kind supporting only a concentrated load  $W$ , the resilience is evidently—

$$\frac{1}{2} \cdot W \times (\text{deflection at the load}) \quad \dots (2)$$

*e.g.* a cantilever carrying an end load  $W$  has a deflection—

$$\frac{Wl^3}{3EI} \quad (\text{see (2), Art. 79})$$

hence the resilience is—

$$c \times \frac{p^2}{E} \times \text{volume} = \frac{1}{2} \cdot \frac{W^2 l}{3EI}$$

If the beam is of rectangular section, the breadth being  $b$  and the depth  $d$ —

$$p = Wl \div \frac{1}{6}bd^2$$

$$\text{volume} = bdl$$

and  $I = \frac{1}{12} b d^3$   
 hence  $c = \frac{1}{18}$ , or resilience =  $\frac{1}{18} \cdot \frac{P^2}{E} \cdot b d l \dots (3)$

For any shape of cross-section, if the radius of gyration about the neutral axis is  $k$ —

since  $p = Wl \div \frac{2I}{a}$  and area of section =  $I \div k^2$

from (1)—

$$\text{resilience} = c \times \frac{W^2 l^2 a^2}{4 I^2 E} \times \frac{I}{k^2} \times l = \frac{1}{2} \times \frac{W^2 l^3}{3 EI}$$

hence  $c = \frac{2}{3} \left(\frac{k}{a}\right)^2$  and resilience =  $\frac{2}{3} \cdot \frac{k^2}{a^2} \cdot \frac{P^2}{E} \times \text{volume}$

e.g. for the rectangular section  $\left(\frac{k}{a}\right)^2 = \frac{1}{12}$ , for standard I sections  $\frac{k}{a}$  is usually about 0.4.

The same coefficients, etc., as those above will evidently hold for a beam simply supported at its ends, and carrying a load midway between them.

If all the dimensions are in inches and the loads in tons, the resilience will be in inch-tons.

If with the notation of Art. 77, in a short length of beam  $dx$ , over which the bending moment is  $M$ , the change of slope is  $di$ , the elastic strain energy of that portion is—

$$\frac{1}{2} \cdot M \cdot di \dots (4)$$

and over a finite length the resilience is—

$$\frac{1}{2} \int M di \dots (5)$$

which may also be written—

$$\frac{1}{2} \int M \frac{di}{dx} dx = \frac{1}{2} \int M \frac{d^2 y}{dx^2} dx = \frac{1}{2} \int \frac{M^2}{EI} dx \dots (6)$$

or, if  $EI$  is constant—

$$\frac{1}{2EI} \int M^2 dx \dots (7)$$

From these forms the resilience of any beam may be found when the bending-moment diagram is known. For a beam of uniform section and length  $l$ , subjected to “simple bending” (see Arts. 61 and 76), for which the bending moment and curvature are constant, the resilience, from (4) or (7), is—

$$\frac{1}{2} M \times \text{change in inclination of extreme tangents} = \frac{1}{2} \frac{M^2 l}{EI} \dots (8)$$

If such a beam is rectangular in section, the breadth being  $b$  and

the depth  $d$ ,  $p = M \div \frac{1}{6}bd^2$ , and in the form (1), the resilience, from (7), is—

$$c \times \frac{p^2}{E} \times \text{volume} \quad \text{or} \quad c \times \frac{36M^2}{Eb^2d^4} \times bdl = \frac{1}{2} \cdot \frac{M^2l \times 12}{Ebd^3}$$

hence  $c = \frac{1}{6}$ , and the resilience =  $\frac{1}{6} \frac{p^2}{E} \cdot bdl$

The same coefficient ( $\frac{1}{6}$ ) will hold for any of the rectangular beams of uniform bending strength, in which the same maximum intensity of skin stress  $p$  is reached at every cross-section, and which bend in circular arcs. For circular sections the corresponding coefficient is  $\frac{1}{8}$ .

In the case of a distributed load  $w$  per unit length of span, the resilience corresponding to (2) may be written—

$$\frac{1}{2} \int w y dx \dots \dots \dots (9)$$

where  $y$  is the deflection at a distance  $x$  from the origin.

*Beam Deflections calculated from Resilience.*—In equation (2) the deflection has been used to calculate the elastic strain energy. Similarly, if the resilience is calculated from the bending moments by (5) or (7), the deflections may be obtained from the resilience. For example, in the case given in Art. 80, of a non-central load  $W$  on a simply supported beam, using the notation of Art. 80 and Fig. 116, taking each end as origin in turn, and integrating over the whole span, using (7)—

$$\frac{1}{2} \cdot y_c \cdot W = \frac{1}{2} \int \frac{M^2}{EI} dx = \frac{1}{2EI} \int_0^a \left( \frac{bW}{a+b} x \right)^2 dx + \frac{1}{2EI} \int_0^b \left( \frac{aW}{a+b} x \right)^2 dx$$

hence— 
$$y_c = \frac{Wa^2b^2}{3(a+b)EI}$$

which agrees with (8), Art. 80.

Taking as a second example the case (b), Art. 78, and Fig. 112, of a uniformly spread load  $w$  per unit span on a beam simply supported at each end, at a distance  $x$  from either support—

$$M = \frac{w}{2} (lx - x^2) \quad (\text{see Fig. 65})$$

To find the deflection at a distance  $a$  from one end, consider the effect of a very small weight  $W$  placed at that section. It would cause an additional bending moment—

$$EI \frac{d^2y}{dx^2} \quad \text{or} \quad EI \frac{di}{dx} = \frac{l-a}{l} \cdot W \cdot x$$

at a distance  $x$  from the end anywhere over the range of length  $a$ ; hence over this portion—

$$di = \frac{l-a}{l} \cdot \frac{Wx}{EI} dx$$

and similarly for the remainder at a distance  $x$  from the other end—

$$di = \frac{a}{l} \cdot \frac{Wx}{EI} \cdot dx$$



Hence from (5) the total increase of strain energy in the whole beam due to  $W$  would be—

$$\frac{1}{2} \int M di = \frac{1}{2} \frac{W}{EI} \cdot \frac{w}{2} \left\{ (l-a) \int_0^a (lx^2 - x^3) dx + a \int_0^{l-a} (lx^2 - x^3) dx \right\}$$

$$= \frac{1}{2} \cdot W \cdot y$$

Reducing this,  $y = \frac{wa(l-a)}{24EI} (l^2 + la - a^2)$

which agrees with (9), Art. 78, when  $x$  is written instead of  $a$ .

Generalising this for any type of beam, take  $W = 1$ , and let  $m$  be the bending moment at any section due to unit weight at the particular section the deflection at which is  $y$ , then  $di = \frac{m}{EI} \cdot dx$ .

$$\frac{1}{2} \times 1 \times y = \frac{1}{2} \int M di = \frac{1}{2} \int \frac{Mm}{EI} dx \quad \text{or} \quad y = \int \frac{Mm}{EI} dx \quad (10)$$

the integration being over the whole length of the beam and if necessary divided into separate ranges with convenient origins. In the particular case of the deflection under a load  $W$ ,  $M = Wm$ , and—

$$y = W \int \frac{m^2}{EI} dx \quad \dots \dots \dots (11)$$

*Carriage Springs.*—The resilience of a carriage spring constructed as indicated in Art. 83, Fig. 122a, would be—

$$\frac{1}{6} \cdot \frac{p^2}{E} \times (\text{volume of material})$$

This may be verified from (11), Art. 83, for the resilience—

$$c \times \frac{p^2}{E} \times \text{volume} = \frac{1}{2} W \times \text{deflection} = \frac{1}{2} W \times \frac{3}{8} \frac{Wl^3}{nEbd^3}$$

and from (10), Art. 83—

$$p = \frac{3}{2} \cdot \frac{Wl}{nbd^2}$$

Substituting this value of  $p$ —

$$c \times \frac{9}{4} \frac{W^2 l^2}{n^2 b^2 d^4} \times \frac{1}{E} \times \frac{nbdl}{2} = \frac{3}{16} \frac{W^2 l^3}{nEbd^3}$$

hence  $c = \frac{1}{6}$ , and the resilience is  $\frac{1}{6} \frac{p^2}{E} \cdot \text{volume}$  or  $\frac{1}{12} \frac{p^2}{E} \cdot nbdl$

Or, under proof load, the resilience is  $\frac{1}{6} \cdot \frac{f^2}{E} \times \text{volume of spring}$ , where  $f$  is the intensity of bending stress at the elastic limit. The value of  $f$  for steel would usually be about 12 to 15 tons per square inch, and that of  $E$  13,000 tons per square inch, so that the proof resilience would be about 0.002 inch-ton, or say 5 inch-lbs., per cubic inch of steel.

EXAMPLE.—A beam of rectangular section is supported at its ends, and carries a uniformly distributed load. Find the resilience in terms of the greatest intensity of stress, and the volume of the beam.

Using the notation of Fig. 65—

$$M = \frac{w}{2} (lx - x^2)$$

the total resilience from (7) is—

$$\frac{1}{2EI} \int M^2 dx = \frac{1}{2EI} \cdot \frac{w^2}{4} \int_0^l (l^2 x^2 - 2lx^3 + x^4) dx = \frac{w^2 l^5}{240EI}$$

If the breadth of section is  $b$  and the depth  $d$ , the greatest intensity of stress  $p$  occurring at mid-span is  $\frac{1}{8}wl^2 \div \frac{1}{6}bd^2 = \frac{3}{4} \frac{wl^2}{bd^2}$

and  $c \cdot \frac{p^2}{E} \cdot \text{volume}$  or  $\frac{c}{E} \cdot \frac{9}{16} \cdot \frac{w^2 l^4}{b^2 d^4} \times bdl = \frac{w^2 l^5 \times 12}{240 E b d^3}$

hence  $c = \frac{4}{45}$  and resilience  $= \frac{4}{45} \times \frac{p^2}{E} \times \text{volume}$

This might also be obtained as the sum

$$\frac{1}{2} \int_0^l wy dx$$

using the expression (9) of Art. 78 for  $y$ .

**93a. Impact producing Flexure.**—If an impulsive load such as that of a falling weight be applied transversely to a bar so as to produce flexure and the limits of proportionality of stress to strain are not exceeded, the strain energy or resilience of the bar at the extremity of the deflection is equal to the kinetic energy and potential energy (if any) of the load and bar immediately after the impact. If the inertia of the bar is negligible in comparison with that of the load and the supports are rigid, the loss of kinetic energy at impact is negligible, and the resilience of the bar is equal to the kinetic energy of the load before impact.

Let the bar be supported freely at its ends, and the load  $W$  fall through a height  $h$  on to the bar of span length  $l$ , midway between the supports, as in Fig. 111. Let  $\delta = y_c =$  deflection under the central impulsive load  $W$ , and let  $P$  be the equivalent static load, *i.e.* the central load, which would produce the same deflection and the same bending stresses, then from (4) Art. 78.

$$\delta = \frac{Pl^3}{48EI} \text{ or } P = \frac{48EI\delta}{l^3} \quad \dots \dots (1)$$

If the weight of the bar is negligible, equating the work done by  $W$  to the resilience after the deflection—

$$W(h + \delta) = \frac{1}{2}P\delta = \frac{24EI\delta^2}{l^3}$$

or,  $W\left(h + \frac{Pl^3}{48EI}\right) = \frac{1}{96} \frac{P^2 l^3}{EI} \quad \dots \dots (2)$

$$P^2 - 2WP - \frac{96EIWh}{l^3} = 0$$

$$P = W + \sqrt{W^2 + \frac{96EIWh}{l^3}} \text{ and } P - W = \sqrt{W^2 + \frac{96EIWh}{l^3}} \quad (3)$$

and if  $\delta$  is negligible compared to  $h$ —

$$P - W = P = \sqrt{\frac{96EIWh}{l^3}} \dots \dots \dots (4)$$

*Correction for Inertia of the Bar.*—If the effect of the bar is small but not negligible, for the purpose of an estimate the deflection may be assumed to take the same form as for a concentrated static load (2) and (4), Art. 78, Fig. 111, viz.—

$$\frac{y}{y_c} = 1 - 6\left(\frac{x}{l}\right)^2 + 4\left(\frac{x}{l}\right)^3 \dots \dots \dots (5)$$

Then if  $v$  = velocity of the centre of the bar just after impact the velocity at a distance  $x$  from the centre is  $v \times \frac{y}{y_c}$ . From the equality of the total momentum before and after impact, if  $w$  = weight of the bar per unit length—

$$W \times \sqrt{2gh} = Wv + 2w \frac{v}{y_c} \int_0^{tl} y dx$$

and substituting for  $y$  from (5), this becomes—

$$W \cdot \sqrt{2gh} = v(W + \frac{5}{8}wl) \text{ or } v = \frac{1}{1 + \frac{5}{8} \frac{wl}{W}} \times \sqrt{2gh} \quad (6)$$

Again, equating kinetic energy plus work done after impact to the increase of strain energy—

$$\frac{1}{2} \frac{W}{g} \cdot v^2 + 2 \times \frac{1}{2} \frac{w}{g} \cdot \frac{v^2}{y_c^2} \int_0^{tl} y^2 dx + W \cdot \delta + 2w \int_0^{tl} y dx = \frac{1}{2} P \cdot \delta + 2w \int_0^{tl} y dx \quad (7)$$

or substituting from (5) and (1)—

$$P^2 - 2P \cdot W - \frac{48EI}{l} \cdot \frac{v^2}{g} (W + \frac{17}{35}wl) = 0 \dots \dots (8)$$

and substituting for  $v$  from (6), and solving the quadratic—

$$P = W + \sqrt{W^2 + \frac{96EI \cdot h \cdot W}{l^3} \cdot \frac{1 + \frac{17}{35} \cdot \frac{wl}{W}}{(1 + \frac{5}{8} \cdot \frac{wl}{W})}} \quad (9)$$

The quantity  $P - W$  is the amount by which impact load exceeds the static load  $W$ ; its ratio to  $W$  diminishes with increase of  $W$ , and the impact bending stress bears the same ratio to the static bending stress. If  $\delta$  is negligible compared to  $h$ , the work is simplified by the omission of the term  $W \cdot \delta$  in (7) and the first term ( $W^2$ ) under the radical sign in (9) disappears.

*Fixed Ends.*—In the case of the bar being fixed in direction at both ends and subjected to an impulsive load  $W$  midway between its ends, using the results of Art. 86, in place of (5), the coefficient  $\frac{17}{35}$  is replaced by  $\frac{13}{35}$ , and the coefficient  $\frac{5}{8}$  by  $\frac{1}{2}$ .

*Cantilever.*—In the case of a cantilever receiving the impact of a falling weight  $W$  at its free end, using the results of Art. 79 in place of (5), the coefficient  $\frac{17}{35}$  is replaced by  $\frac{33}{140}$ , and the coefficient  $\frac{5}{8}$  by  $\frac{3}{8}$ .

*More General Positions of Points of Incidence of Load.*—The effect of the inertia of the bar may be similarly found in more general cases by the same methods as above, using the results of Arts. 79, 80, and 87 (Ex. 2), and splitting the integration into suitable ranges.

**94. Transverse Curvature.**—If a horizontal beam is bent so as to be concave upwards, the upper fibres are compressed and the lower ones stretched, hence lateral expansion and contraction will make the upper portion of the beam wider and the lower portion narrower. These lateral strains (Arts. 12 and 19), being proportional to the longitudinal ones, are proportional to the distances from the neutral surface, and transverse bending accompanies the longitudinal flexure. The amount of the transverse curvature may be found from the strains in exactly the same way as the longitudinal curvature (Arts. 61 to 63).

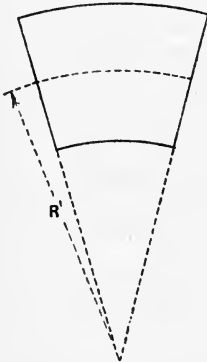

The transverse strains are  $\frac{1}{m}$  times the longitudinal ones,  $\frac{1}{m}$  being Poisson's ratio, and the curvature is therefore  $\frac{1}{m}$  times the longitudinal curvature. Hence, if  $R'$ , Fig. 138, is the radius of transverse curvature—

$$\frac{1}{R'} = \frac{1}{mR} \quad \text{or} \quad R' = mR$$

where  $R$  is the radius of longitudinal curvature.

It is here assumed that lateral movement is free, just as free longitudinal strain, uninfluenced by surrounding layers, was assumed in Art. 61. This is nearly true for sections, the depth of which is greater than the width, but is not true for broad, flat strips. In very broad beams practically no transverse curvature occurs, except near the edges, where a lateral strain is free to take place. This approximates to a

case where lateral strain is prevented in one direction, and the modulus of elasticity appropriate to such a case of flexure is a modification of the ordinary direct modulus (see Art. 21).

Using the equations of Art. 19, the direction of  $e_1$  being the length of the beam, and that of  $e_2$  being the breadth,  $p_3$  being zero, equation (1), Art. 19, gives—

$$e_1 = \frac{p_1}{E} - \frac{p_2}{mE}$$

and equation (2), Art. 19, gives—

$$0 = \frac{p_2}{E} - \frac{p_1}{mE}$$

hence 
$$e_1 = \frac{p_1}{E} \left( 1 - \frac{1}{m^2} \right) = \frac{p_1(m^2 - 1)}{m^2 E} \quad \text{or} \quad p_1 = e_1 \times E \frac{m^2}{m^2 - 1}$$

the quantity 
$$\frac{m^2}{m^2 - 1} \cdot E$$

being a modified modulus of elasticity, which if  $m = 4$  is  $\frac{16}{15}$  times  $E$ , and for such cases of flexure longitudinal deflections are only about  $\frac{15}{16}$  of what might be expected if the lateral strains were free.

EXAMPLE.—A piece of iron plate, rectangular in section, 4 inches wide and  $\frac{1}{2}$  inch thick, is placed on horizontal supports 3 feet apart, the long side of the cross-section being horizontal, and a load of 200 lbs. is placed at the centre; the central deflection is 0.149 inch. The plate is then placed on the supports with the long side vertical, and a central load of 2000 lbs. causes a central deflection of 0.025 inch. Find the value of Poisson's ratio for this material.

In the first position  $I = \frac{1}{12} \cdot 4 \cdot \frac{1}{8} = \frac{1}{24}$ .

Using the formula (4), Art. 78, with modified modulus—

$$\frac{m^2}{(m^2 - 1)} \cdot E = \frac{200 \times 36 \times 36 \times 36}{48 \times \frac{1}{24} \times 0.149} = 31,312,750$$

And in the second position  $I = \frac{1}{12} \cdot \frac{1}{2} \cdot \frac{64}{1} = \frac{8}{3}$

$$E = \frac{2000 \times 36 \times 36 \times 36 \times 3}{48 \times 8 \times 0.025} = 29,160,000$$

Dividing the previous result by this—

$$\frac{m^2}{m^2 - 1} = 1.0738 \qquad m^2 = \frac{1.0738}{0.0738} = 14.55$$

$$m = 3.81 \qquad \frac{1}{m} = 0.263$$

**95. Elastic Energy in Shear Strain; Shearing Resilience.**—When material suffers shear strain within the elastic limit, elastic strain energy is stored just as in the case of direct stress and strain. For simple distributions of shear stress the resilience or elastic strain energy is easily calculated. Let Fig. 9 represent a piece of material of length

$l$  perpendicular to the plane of the diagram, having uniform shear stress of intensity  $q$  on the face BC, causing shear strain  $\phi$  and deflection  $BB''$ .

Then the resilience evidently is—

$$\begin{aligned} \frac{1}{2} \times (\text{force}) \times (\text{distance}) &= \frac{1}{2} \times (BC \cdot l \cdot q) \times BB'' = \frac{1}{2} \cdot BC \cdot l \cdot q \cdot AB\phi \\ &= \frac{1}{2} \cdot BC \cdot l \cdot AB \cdot \frac{q^2}{N} \\ &= \frac{1}{2} \cdot \frac{q^2}{N} \times \text{volume} \text{ or } \frac{1}{2} \frac{q^2}{N} \text{ per unit of volume} \end{aligned}$$

where  $N$  is the modulus of rigidity.

Note the similarity to the expression  $\frac{1}{2} \frac{p^2}{E}$  per unit volume, which is the resilience for uniformly distributed direct stress (Art. 42).

**96. Deflection of a Beam due to Shearing.**—In addition to the ordinary deflections due to the bending moment calculated in Chap. VI., there is in any given case other than “simple bending” (Art. 64) a further deflection due to the vertical shear stress on transverse sections of a horizontal beam. This was not taken into account in the calculations of Chap. VI., and the magnitude of it in a few simple cases may now be estimated.

In the case of a cantilever of length  $l$  carrying an end load  $W$  (Fig. 59), if the shearing force  $F$  ( $= W$ ) were uniformly distributed over vertical sections, the deflections due to shear at the free end would be—

$$l \times (\text{angle of shear strain})$$

$$\text{or} \quad \phi \cdot l = \frac{q}{N} l \text{ or } \frac{Wl}{AN}$$

where  $A$  is the area of cross-section. If the section were rectangular, of breadth  $b$  and depth  $d$ , the deflection with uniform distribution would be  $\frac{Wl}{bd \cdot N}$ .

But we have seen (Art. 71) that the shear stress is not uniformly distributed over the section, but varies from a maximum at the neutral surface to zero at the extreme upper and lower edges of the section. The consequence is that the deflection will be rather more than  $\frac{Wl}{AN}$ . We can get some idea of its amount in particular cases from the distribution of shear stress calculated in Art. 71. But it should be remembered that such calculations are based on the simple theory of bending (see Art. 64), and are approximate only. While the simple (or Bernoulli-Euler) theory gives the deflections due to the bending moment with sufficient accuracy, the portion of the total deflection which is due to shearing cannot generally be estimated with equal accuracy from the distribution of shear stress deduced in Art. 71. It becomes desirable, then, to check the results by those given in the more complex theory of St. Venant (see Art. 64) if a very accurate estimate of shearing deflection is required. In a great number of practical cases,

however, the deflection due to shearing is negligible in comparison with that caused by the bending moment. Assuming the distribution of shear stress to be as calculated in Art. 71, and constant over a narrow strip of the cross-section parallel to the neutral axis of the section, a few deflections due to shear will now be calculated for cases where the shearing force is uniform, and for which the simple theory of bending is approximately correct (see Art. 64).

*Cantilever of Rectangular Section with End Load.*—The breadth being  $b$  and the depth  $d$ , a longitudinal strip of length  $l$ , width  $b$ , and thickness  $dy$ , parallel to the neutral surface and distant  $y$  from it, will store strain energy—

$$\frac{1}{2} \cdot \frac{q^2}{N} \cdot b \cdot l \cdot dy \quad (\text{see Art. 95})$$

due to shear strain. And from (4), Art. 71—

$$q = \frac{6F}{bd^3} \left( \frac{d^2}{4} - y^2 \right)$$

where  $F = W$ , the end load.

Hence

$$q^2 = \frac{36W^2}{b^2d^6} \left( \frac{d^4}{16} + y^4 - \frac{d^2y^2}{2} \right)$$

The total shearing resilience in the cantilever is—

$$\frac{bl}{2N} \int_{-\frac{d}{2}}^{\frac{d}{2}} q^2 dy = \frac{18W^2l}{Nbd^6} \int_{-\frac{d}{2}}^{\frac{d}{2}} \left( \frac{d^4}{16} - \frac{d^2y^2}{2} + y^4 \right) dy \quad \dots (1)$$

or

$$\frac{36W^2l}{Nbd^6} \left( \frac{yd^4}{16} - \frac{y^3d^2}{6} + \frac{y^5}{5} \right)_0^{\frac{d}{2}} = \frac{3}{5} \frac{W^2l}{Nbd}$$

If  $\delta$  be the deflection at the free end due to shearing, the shearing resilience is  $\frac{1}{2} \cdot W \cdot \delta = \frac{3}{5} \frac{W^2l}{Nbd}$ , hence—

$$\delta = \frac{6}{5} \frac{Wl}{Nbd} = \frac{6}{5} \times \left( \frac{\text{mean value of } q}{N} \right) \times (l)$$

which is 20 per cent. greater than it would be with uniformly distributed shear stress.

Similarly, for a beam simply supported at its ends and of length  $l$ , carrying a central load  $W$ , putting  $\frac{l}{2}$  for  $l$ , and  $\frac{W}{2}$  for  $W$ , the shearing deflection is—

$$\frac{3}{10} \cdot \frac{Wl}{Nbd}$$

or the total deflection due to bending and shearing is—

$$\frac{Wl^3}{48EI} + \frac{3}{10} \frac{Wl}{Nb\bar{d}} = \frac{Wl^3}{4Eb\bar{d}^3} \left\{ 1 + \frac{E}{N} \left( \frac{\bar{d}}{l} \right)^2 \right\}$$

or if  $\frac{E}{N} = \frac{5}{2}$ , this becomes—

$$\frac{Wl^3}{4Eb\bar{d}^3} \left\{ 1 + 3 \left( \frac{\bar{d}}{l} \right)^2 \right\}$$

or for the cantilever—

$$\frac{4Wl^3}{Eb\bar{d}^3} \left\{ 1 + \frac{3}{4} \left( \frac{\bar{d}}{l} \right)^2 \right\}$$

The second term is negligible if  $\left( \frac{l}{\bar{d}} \right)$  is large, which is generally the case in practice. This expression for the shearing deflection is in fair agreement with the more exact expression deduced by St. Venant,<sup>1</sup> provided the breadth is not great compared with the depth.

*Circular Section.*—In a cantilever of circular section, assuming uniform distribution of shear stress in a horizontal direction across the section and vertical variation as in (5), Art. 71,  $q = \frac{4F}{3\pi R^2} \cos^2 \theta$ , where  $y = R \sin \theta$ ,  $z = 2R \cos \theta$ ,  $dy = R \cos \theta d\theta$  (see Fig. 99), and the integral resilience corresponding to (1) is—

$$2 \cdot \frac{l}{2N} \cdot \frac{16W^2}{9\pi^2 R^4} \cdot 2R^2 \int_0^{\frac{\pi}{2}} \cos^6 \theta \cdot d\theta = \frac{5}{9} \frac{W^2 l}{\pi N R^2} = \frac{1}{2} W \delta$$

hence 
$$\delta = \frac{10}{9} \cdot \frac{W}{\pi R^2} \cdot \frac{l}{N} = \frac{10}{9} \times \frac{\text{mean value of } q \times l}{N}$$

And the *total* deflection in a length  $l$  is—

$$\frac{Wl^3}{3EI} + \frac{10}{9} \cdot \frac{W}{\pi R^2} \cdot \frac{l}{N} = \frac{64Wl^3}{3\pi d^4 E} \left\{ 1 + \frac{5}{24} \cdot \frac{E}{N} \cdot \left( \frac{\bar{d}}{l} \right)^2 \right\}$$

or 
$$\frac{64Wl^3}{3\pi d^4 E} \left\{ 1 + \frac{25}{48} \left( \frac{\bar{d}}{l} \right)^2 \right\} \text{ if } \frac{E}{N} = \frac{5}{2}$$

For the simply supported beam the deflection is—

$$\frac{4Wl^3}{3\pi d^4 E} \left\{ 1 + \frac{5}{6} \frac{E}{N} \left( \frac{\bar{d}}{l} \right)^2 \right\} \text{ or } \frac{4Wl^3}{3\pi d^4 E} \left\{ 1 + \frac{25}{12} \left( \frac{\bar{d}}{l} \right)^2 \right\} \text{ if } \frac{E}{N} = \frac{5}{2}$$

Here again the second terms are negligible unless the beam is very short. If the beam is very short the distribution of shear stress is not known, and is probably between that calculated in Art. 71 and a uniform distribution.

*Distributed Loads.*—With a distributed load the simple theory of bending does not hold with the same accuracy as when the vertical

<sup>1</sup> See Todhunter and Pearson's "History of Elasticity," vol. ii., Arts. 91 and 96.



shearing force on the cross-sections is constant throughout the length (see Art. 64). Neglecting this, however, the resilience due to shear strain of an element of length  $dx$  would be—

$$\frac{1}{2} \frac{q^2}{N} \cdot z \cdot dy \cdot dx$$

If  $z$  and  $y$  are not functions of  $x$ , *i.e.* if the sections of the beam are constant throughout its length, the effect of integrating the energy expressions throughout with respect to  $x$  will be to multiply the previous values for the cantilever by the ratio of  $\int_0^l F^2 dx$  to  $lW^2$ . For example, in the case of a uniformly distributed load  $w$  per unit length at a distance  $x$  from the free end  $F^2 = w^2 x^2$ , hence the above ratio is  $\frac{1}{3} w^2 l^3$  to  $lW^2$  or  $\frac{1}{3} \left(\frac{wl}{W}\right)^2$ , the effect of a distributed load being  $\frac{1}{3}$  that of the same load concentrated at the end. The same coefficient will evidently hold good for a beam freely supported at its ends, and uniformly loaded, compared to similar beam carrying the same load concentrated midway between the supports.

**I-Section Girders.**—The cases in which the shearing deflections are of more importance are the various built-up sections of which girders are made, particularly when the depth is great in proportion to the length. In an I girder section, for example, the intensity of shear stress in the web is (see Art. 71) much greater than the mean intensity of shear stress over the section. A common method of roughly estimating the total deflection of large built-up girders is to calculate for ordinary bending deflection, using a value of  $E$  about 25 per cent. below the usual value to allow for shearing, etc.

*Any Section.*<sup>1</sup>—For any solid section instead of (1) the elastic energy  $\frac{1}{2} W \delta$  would be—

$$\frac{1}{2} W \delta = \frac{l}{2N} \int_{-\frac{d}{2}}^{\frac{d}{2}} q^2 z dy \dots \dots \dots (2)$$

where  $z$  is the breadth of the section at a depth  $y$ , as in Art. 71, and  $q$

=  $\frac{F}{I_z} \int_y^{\frac{d}{2}} yz dy$ , as in Art. 71, hence the strain energy—

$$\frac{1}{2} \cdot W \cdot \delta = \frac{l}{2N} \int_{-\frac{d}{2}}^{\frac{d}{2}} \left\{ \frac{F^2}{I_z^2} \left( \int_y^{\frac{d}{2}} yz dy \right)^2 \right\} dy \dots \dots (3)$$

or for the cantilever symmetrical about the neutral axes of the sections with end load  $W$ , where  $F = W$ —

$$\frac{1}{2} \cdot W \cdot \delta = \frac{W^2 l}{I_z^2 N} \int_0^{\frac{d}{2}} \frac{1}{z} \left( \int_y^{\frac{d}{2}} yz dy \right) dy \text{ and } \delta = \frac{2Wl}{I_z^2 N} \int_0^{\frac{d}{2}} \frac{1}{z} \left( \int_y^{\frac{d}{2}} yz dy \right)^2 dy$$

<sup>1</sup> A general formula applicable to beams of variable section is given by Prof. S. E. Slocum, in the *Journal* of the Franklin Institute, April, 1911.

For a simply supported beam of span  $l$  and central load  $W$ , the deflection would be  $\frac{1}{4}$  of the above expression.

For sections the width ( $z$ ) of which cannot be simply expressed as a function of the distance ( $y$ ) from the neutral surface, a graphical method will be most convenient. The values of  $q$  may be found as in Art. 71 and Fig. 101. A diagram, somewhat similar to Fig. 101, may then be plotted, the ordinates of which are proportional to  $q^2 \times z$  by squaring the ordinates of Fig. 101 and multiplying each by the corresponding width of the section. The total area of this diagram would represent

$\int_{-\frac{d}{2}}^{\frac{d}{2}} q^2 z dy$ , and the deflection of, say, a cantilever may be found from it by

multiplying by  $\frac{l}{N}$  and dividing by  $W$ . If the diagram of  $q$  is not required it is rather more convenient to proceed as follows (see Fig. 139). Draw the ordinary modulus figure for the section as shown at (a), and

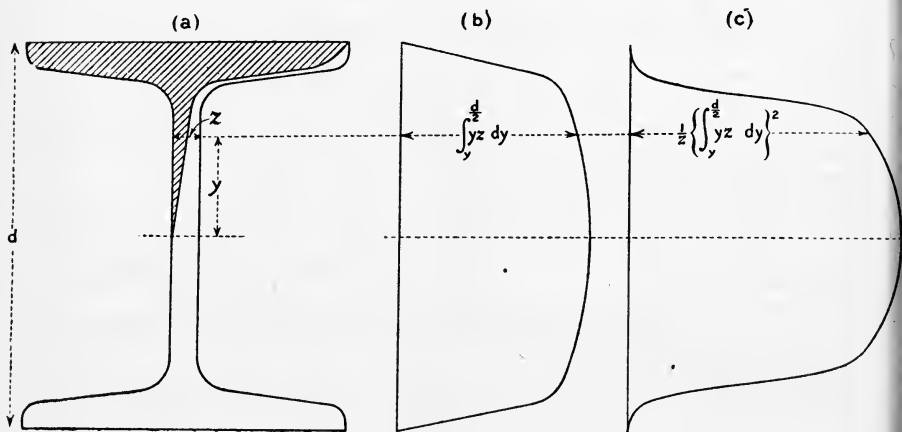

FIG. 139.

plot a diagram (b) showing  $q \cdot z$  instead of  $q$ , on the depth of the beam as a base line. Equation (3), Art. 71, shows that at any height  $y$  from the neutral axis—

$$qz = \frac{W}{I} \times \left( \text{area of modulus figure between } y \text{ and } \frac{d}{2} \right)$$

from which equation the ordinates of (b) may be found by measuring areas on Fig. (a). Square the ordinates of this diagram (b), and divide each by the width  $z$  and plot the results as ordinates of the diagram (c) on the depth  $d$  as a base. The area of the resulting figure (c) represents

$\int_{-\frac{d}{2}}^{\frac{d}{2}} q^2 z dy$  as before, and the deflection (see (2) above) is found by

multiplying by  $\frac{l}{N}$  and dividing by  $W$  for a cantilever with an end load, and is  $\frac{1}{4}$  of this for a beam of length  $l$  supported at its ends and carrying a central load  $W$ , provided  $W$  is used as above in finding  $qz$ , or  $\frac{1}{2}$  this if  $\frac{W}{2}$ , the actual shearing force, is used in finding  $qz$ .

It is, of course, not necessary to actually plot the diagram (*b*).

*Scales.*—Fig. 139 (*a*) being drawn full size, the width of the modulus figure represents  $\frac{2y}{d} \times z$ . If  $p$  square inches of modulus figure area at (*a*) are represented by 1-inch ordinates on (*b*), the ordinates represent  $\int_y^{\frac{d}{2}} yz dy$  on a scale of 1 inch =  $p \times \frac{d}{2}$  (inches)<sup>3</sup>. If the ordinates of (*b*) in inches are square and divided by  $n$ , say, for convenience, and then plotted in inches, on Fig. (*c*), the area of Fig. (*c*) represents  $\int_{-\frac{d}{2}}^{\frac{d}{2}} \frac{1}{n} \left( \int_y^{\frac{d}{2}} yz dy \right)^2 dy$  on a scale of 1 square inch =  $n \left( p \cdot \frac{d}{2} \right)^2$ , the units being (inches)<sup>6</sup>.

To obtain, say, the cantilever deflection, it is only necessary to multiply the result in (inches)<sup>6</sup> by  $\frac{Wl}{I^2N}$ , the units of which are (inches)<sup>-2</sup> when inch units are used for  $l$ ,  $I$ , and  $N$ , to obtain the deflection in inches. For the centrally load beam the factor would be  $\frac{1}{4} \frac{Wl}{I^2N}$ . Fig. 139, when drawn full size, represents the British Standard Beam section, No. 10, for which  $d = 6$  inches,  $I = 43.61$  (inches)<sup>4</sup>, and the web is 0.41 inch thick: the area of the diagram (*c*) represents 761 (inches)<sup>6</sup>, and the shearing deflection of a cantilever would be  $0.416 \frac{Wl}{N}$  inches.

The deflection due to shearing of an **I** beam with square corners such as Fig. 100 may be found by integration in two ranges over which the breadth is constant (see example below), and this method might be used as an approximation for any **I** section by using mean values for the thickness of the flanges and web: an example is given below.

*Simple Approximation for I Sections.*—Owing to the limitations of the simple theory of bending none of these calculations can be regarded as correct, and perhaps the simplest approximation may also be the best, viz. to calculate the deflection due to shear as if the web carried the whole shearing force with uniform distribution, so that for a cantilever—

$$\delta = \frac{Wl}{AN}$$

and for a beam simply supported at its ends—

$$\delta = \frac{Wl}{4AN}$$

where  $A$  is the area of the web and  $l$  is the length of the beam, all the linear units being, say, inches.

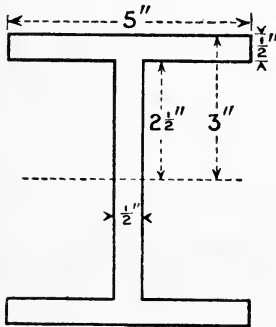

FIG. 140.

EXAMPLE.—Find the ratio of the deflections due to shearing and bending in a cantilever of I section, 6 inches deep and 5 inches wide, the flanges and web each  $\frac{1}{2}$  inch thick, carrying an end load,  $\frac{E}{N}$  being taken as  $\frac{5}{2}$ ,  $I = 43.125$  (inches)<sup>4</sup> (see Fig. 140). In the flanges—

$$q = \frac{W}{I} \int_y^3 y dy = \frac{W}{2I} (9 - y^2)$$

$$q^2 = \frac{W^2}{4I^2} (81 - 18y^2 + y^4)$$

In the web—

$$q = \frac{W}{\frac{1}{2}I} \left( \int_{2\frac{1}{2}}^3 5y \cdot dy + \int_y^{2\frac{1}{2}} \frac{1}{2} \cdot y dy \right) = \frac{2W}{I} \left( \frac{13.5}{16} - \frac{y^2}{4} \right) = \frac{W}{I} \left( \frac{13.5}{8} - \frac{y^2}{2} \right)$$

$$q^2 = \frac{W^2}{I^2} \left( \frac{18225}{64} - \frac{13.5}{8} y^2 + \frac{y^4}{4} \right)$$

Taking both sides of the neutral axis, the total shearing resilience is by (2)—

$$\begin{aligned} \frac{1}{2}W \cdot \delta &= \frac{l}{2N} \int_{-3}^3 q^2 z dy = \frac{l}{2N} \left\{ \frac{5W^2}{4I^2} \int_{2\frac{1}{2}}^3 (81 - 18y^2 + y^4) dy \right. \\ &\quad \left. + \frac{W^2}{2I^2} \int_0^{2\frac{1}{2}} \left( \frac{18225}{64} - \frac{13.5}{8} y^2 + \frac{y^4}{4} \right) dy \right\} \\ \delta &= \frac{2lW}{NI^2} (1.65 + 314.5) = \frac{632Wl}{I^2N} = 0.340 \frac{Wl}{N} \end{aligned}$$

(This agrees closely with the result given for Fig. 139, being less in about the same proportion that the web thickness is greater,  $I$  being nearly the same in each.)

Ratio of deflections  $\frac{\text{shearing}}{\text{bending}} = \frac{632Wl}{I^2N} \times \frac{3EI}{Wl^3} = \frac{1896}{I} \cdot \frac{E}{N} \cdot \frac{l}{l^2}$ , and taking  $I = 43.125$  and  $\frac{E}{N} = \frac{5}{2}$ , this ratio is  $\frac{110}{l^2}$  nearly. For a simply supported beam of span  $l$  the ratio would be  $\frac{440}{l^2}$ , and if the span were 10 times the depth, or 60 inches, the ratio would be  $\frac{440}{3600}$ , or over 12 per cent.

#### EXAMPLES VIII.

1. A strip of steel 1 inch wide and  $\frac{1}{20}$  inch thick is wound on to a drum 8 feet diameter. Find the intensity of stress in the metal and the resilience per foot length of the strip if  $E = 30 \times 10^6$  pounds per square inch.

2. A length of steel wire  $\frac{1}{16}$  inch diameter is wound on a drum 5 feet diameter. Find the work stored per cubic inch and per foot length of wire.  $E = 30 \times 10^6$  lb. per square inch.

3. Find the elastic energy stored per cubic inch in a bar of circular section resting on supports at its ends and carrying a central load. State the result in terms of the greatest intensity of bending stress and the direct modulus of elasticity.

4. If the limits of safe bending stress for steel and ash are in the ratio 8 to 1, and the direct moduli of elasticity for the two materials are in the ratio 20 to 1, compare the proof resilience per cubic inch of steel with that for ash and where both are bent in a similar manner. If steel weighs 480 lbs. per cubic foot and ash 50 lbs. per cubic foot, compare the proof resilience of steel with that of an equal weight of ash.

5. If the safe limit of stress in a carriage spring is 10 tons per square inch, how many cubic inches of material would be necessary to take up 1 inch-ton of energy,  $E$  being 13,000 tons per square inch? If the longest plate is 6 feet 6 inches long and the plates are 4 inches wide by  $\frac{1}{2}$  inch thick, how many would be required? What would be the proof load, proof deflection, and initial radius of curvature?

6. A beam of I section is 20 inches deep and  $7\frac{1}{2}$  inches broad, the thickness of web and flanges being 0.6 inch and 1 inch respectively. If the beam carries a load at the centre of a 20-foot span, find approximately what proportion of the total deflection is due to shearing if the ratio  $\frac{E}{N} = 2.5$ .

## CHAPTER IX.

### *DIRECT AND BENDING STRESSES.*

**97. Combined Bending and Direct Stress.**—It often happens that the cross-section of a pillar or a tie-rod mainly subjected to a longitudinal thrust or pull has in addition bending stresses across it, the pillar or tie-rod suffering flexure in an axial plane; or that the cross-section of a beam resisting flexure has brought upon it further direct stress due to an end thrust or pull, the loads on the beam not being all transverse ones, such as were supposed in Chapters IV. and V., but such as make the beam also a strut or a tie. In either case the resultant longitudinal intensity of stress at any point in a cross-section will be the algebraic sum of the direct stress of tension or compression and the direct stresses due to bending. If  $p$  is the intensity of stress anywhere on a section subjected to an end load—

$$p = p_0 + p_b \dots \dots \dots (1)$$

where  $p_0$  is the total end load divided by the area of cross-section, and  $p_b$  is the intensity of bending stress as calculated from the bending moments for purely transverse loading in Art. 63, and is of the same sign as  $p_0$  in part of the section and of opposite sign in another part. The stress intensity  $p$  will change sign somewhere in the section if the extreme values of  $p_b$  are of greater magnitude than  $p_0$ , but the stress will not be zero at the centroid of the section as in the case of a beam bent only by transverse forces. The effect of the additional direct stress  $p_0$  is to change the position of the neutral surface or to remove it entirely.

**98. Eccentric Longitudinal Loads.**—If the line of action of the direct load on a prismatic bar is parallel to the axis of the bar, and intersects an axis of symmetry of the cross-section at a distance  $h$  from the centroid of the section, bending takes place in the plane of the axis of the bar and the line of action of the eccentric load. Thus, Fig. 141 represents the cross-section of a bar, the load  $P$  passing through the point  $C$ , and  $O$  is the centroid of the section. Let  $A$  be the area of cross-section, and  $y_1$  distance  $OD$  from the centroid  $O$  to the extreme edge  $D$  in the direction  $OC$ , and let  $I$  be the moment of inertia of the area of section about the central axis  $FG$  perpendicular to  $OC$ . Then, in addition to the direct tension or compression  $\frac{P}{A}$  or  $p_0$ , there is a

bending moment  $M = P \cdot h$  on the section, the intensity of stress at any point distant  $y$  from  $FG$  being—

$$p = p_0 + p_b = \frac{P}{A} + \frac{P \cdot h \cdot y}{I} \quad (\text{Art. 63})$$

or since  $I = Ak^2$ , where  $k$  is the radius of gyration about  $FG$ —

$$p = \frac{P}{A} + \frac{Phy}{Ak^2} = \frac{P}{A} \left( 1 + \frac{h \cdot y}{k^2} \right) \text{ or } p_0 \left( 1 + \frac{hy}{k^2} \right) \dots (1)$$

$y$  being positive for points on the same side of  $FG$  as  $C$ , and negative on the opposite side. The intensity varies uniformly with the dimension  $y$ , as shown in Figs. 141, 142.

The extreme stress intensities at the edges of the section will be—

$$p_0 + f_1 \text{ and } p_0 - f_1'$$

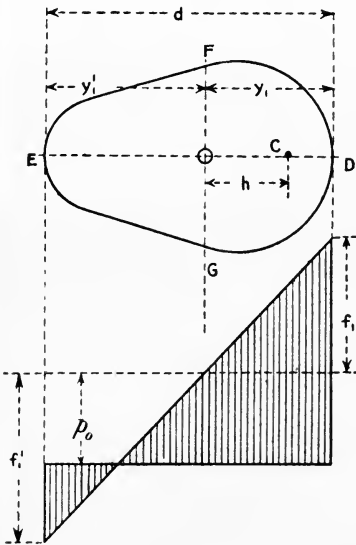

FIG. 141.

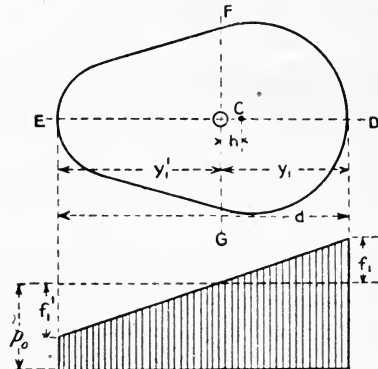

FIG. 142.

where  $f_1$  and  $f_1'$  are the opposite extreme values of  $p_b$ , or if  $y_1$  and  $y_1'$  are the distances of the extreme edges from the centroid  $O$ , the extreme stress intensities of stress are—

$$p = p_0 \left( 1 + \frac{hy_1}{k^2} \right) \text{ and } p = p_0 \left( 1 - \frac{hy_1'}{k^2} \right) \dots (2)$$

on the extreme edges  $D$  and  $E$ , the former being on the same side of the centroid as  $C$ , and the latter on the opposite side. If the section is symmetrical about  $FG$ —

$$y_1 = y_1' = \frac{d}{2}$$

Evidently  $p = 0$  for  $y = -\frac{k^2}{h}$  if this distance is within the area of cross-section, *i.e.* if  $\frac{k^2}{h}$  is less than  $y_1'$  the distance from the centroid to

the edge E opposite to C. An axis parallel to FG and distant  $\frac{k^2}{h}$  from it on the side opposite to C might be called the neutral axis of the section, for it is the intersection of the area of cross-section by a surface along which there is no direct longitudinal stress. The uniformly varying intensity of stress where  $h$  is greater than  $\frac{k^2}{y_1}$  is shown in Fig. 141.

If  $\frac{k^2}{h}$  is greater than  $y_1'$ , i.e. if  $h$  is less than  $\frac{k^2}{y_1'}$  the stress throughout the section is of the same kind as  $p_0$ ; this uniformly varying distribution of stress is shown in Fig. 142. With loads of considerable eccentricity, it should be noted, such metals as cast iron, which are strong in compression, ultimately fail in tension under a compressive load.

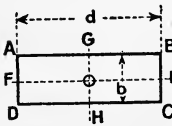

FIG. 143.

*Rectangular Section.*—In the rectangular section of breadth  $b$  and depth  $d$ , shown in Fig. 143, in order that the stress on the section shall be all of the same sign, the maximum deviation in the direction OE of the line of action of the resultant stress from the line GH through the centroid is—

$$h = k^2 \div y = \frac{1}{12}d^2 \div \frac{d}{2} = \frac{d}{6}$$

From this result springs the well-known rule for masonry, in which no tension is allowed—that across a rectangular joint the resultant thrust across the joint must fall within  $\frac{1}{6}$  of the thickness from the centre line of the joint, or *within the middle third*. The limiting deviation in the direction OG under the same conditions is  $\frac{1}{6}b$ .

If the line of action of the stress is on neither of the centre lines of the section, the bending is unsymmetrical, and may conveniently be resolved in the planes of the two principal axes as in Art. 68a. If the line of action of P fall in the quarter GOEB say, at a point the co-ordinates of which, referred to OE and OG as axes, are  $x$  and  $y$  measured positive toward E and G respectively, the bending moment about OE is  $P.y$ , and about OG is  $P.x$ , and the stress at any point in the section the co-ordinates of which are  $x', y'$ , is—

$$p = \frac{P}{bd} + \frac{P.y.y'}{\frac{1}{12}db^3} + \frac{P.x.x'}{\frac{1}{12}bd^3} = \frac{12P}{bd} \left( \frac{1}{12} + \frac{y.y'}{b^2} + \frac{x.x'}{d^2} \right). \quad (3)$$

The least value of this is evidently always at D, where  $x' = -\frac{d}{2}$  and  $y' = -\frac{b}{2}$  when the least value of  $p$  is—

$$\frac{6P}{bd} \left( \frac{1}{6} - \frac{y}{b} - \frac{x}{d} \right)$$

This just reaches zero when

$$\frac{y}{b} + \frac{x}{d} = \frac{1}{6}, \text{ or } y = -\frac{b}{d}x + \frac{b}{6}$$



the equation to the straight line joining points  $\frac{b}{6}$  from O along OG, and  $\frac{d}{6}$  from O along OE. Similar limits will apply in other quarters of the rectangle, and the stress will be of the same sign in all parts of the section, provided the line of the resultant load falls within a rhombus the diagonals of which lie along EF and GH, and are of length  $\frac{d}{3}$  and  $\frac{b}{3}$  respectively. This rhombus is called the *core* of the section.

*Circular Section.*—In the case of a circular section of radius R, the deviation which just produces zero stress at one point of the perimeter of the section and double the average intensity diametrically opposite is—

$$h = k^2 \div R = \frac{R^2}{4} \div R = \frac{1}{4}R$$

and for a hollow circular section of internal radius  $r$  and external radius R the deviation would be—

$$h = \frac{R^2 + r^2}{4R}$$

which approaches the limit  $\frac{1}{2}R$  in the case of a thin tube.

*Other Sections.*—A more general form of (3) is evidently—

$$p = \frac{P}{A} \left( 1 + \frac{yy'}{k_x^2} + \frac{xx'}{k_y^2} \right) \dots \dots \dots (4)$$

where  $k_x$  and  $k_y$  are the radii of gyration of the area of section about the axes of  $x$  and  $y$  respectively, and for zero stress at a point the co-ordinates of which are  $x', y'$ —

$$\frac{yy'}{k_x^2} + \frac{xx'}{k_y^2} = -1 \dots \dots \dots (5)$$

For a symmetrical I section of breadth  $b$  in the direction of  $x$ , and depth  $d$  in the direction of  $y$ , the four corners will be limiting points of zero stress, and the limits of deviation of load from the centroid for no change in sign of the stress will be the bounding line—

$$y = -\frac{k_x^2}{k_y^2} \cdot \frac{b}{d} x - \frac{2k_x^2}{d} \dots \dots \dots (6)$$

and three others forming a rhombus having the principal axes as diagonals. Similar bounding lines will fix the deviation limits or cores for various other sections the boundaries of which can be circumscribed by polygons.

For a symmetrical I section such as Fig. 82, if the axis OY is taken as the vertical principal axis of the section, for a corner—

$$x' = \frac{b}{2} \text{ and } y' = \frac{d}{2}$$

If  $x$  and  $y$  are the co-ordinates of the centre of the loading, the unit stress from (4) is—

$$p = \frac{P}{A} \left( \frac{yd}{2k_x^2} + \frac{xb}{2k_y^2} + 1 \right) \quad \text{or} \quad \frac{p}{p_0} - 1 = \frac{yd}{2k_x^2} + \frac{xb}{2k_y^2} \quad (7)$$

For various values of  $\frac{p}{p_0}$ , equation (7) would represent a series of straight lines on which the load centre would lie; the inclination of the lines to the axis OX would be at an angle  $\theta$  such that—

$$\tan \theta = - \frac{k_x^2}{k_y^2} \cdot \frac{b}{d} \quad \dots \quad (8)$$

and equation (6) is the particular line for  $p = 0$ . The minimum eccentricity of loading to give any ratio  $\frac{p}{p_0}$  at the corner of the section would occur when a line joining the centroid to the load centre is perpendicular to the lines represented by (7), *i.e.* inclined to the axis OX at an angle the tangent of which is—

$$\frac{k_y^2}{k_x^2} \cdot \frac{d}{b} \quad \dots \quad (9)$$

*Common examples* of eccentric loads occur in tie-bars “cranked” to avoid an obstacle, frames of machines, such as reciprocating engines, members of steel structures, and columns or pillars of all kinds; but it is to be remembered that, particularly in the case of pillars, the deviation  $h$  is a variable along the length if flexure takes place. Frequently, however, in columns which are short in proportion to their cross-sectional dimensions, and in which the deviation  $h$  of resultant thrust from the axis is considerable, this variation in  $h$  is negligible.

*Crane Hooks.*—The formulæ (1) and (2) are very frequently applied to find the extreme stress intensities in crane and coupling hooks due to the pull, the axis of which is at a considerable distance from the centroid of the middle section of the hook. It has been shown to be wrong to use the theory applicable to a straight beam to such bending of a hook of very considerable curvature, the effect being to underestimate the tensile stress at the inside of the hook (often by nearly 50 per cent.), and to overestimate the compression at the outside. The subject is treated in Art. 132.

*Masonry Seating for Beam Ends.*—If we assume the forces exerted by the walls on a cantilever or a built-in beam to consist of a uniform upward pressure equal to the total vertical reaction  $R$  and equal upward and downward pressures varying in intensity uniformly along the length from zero at the centre of the seating to maxima at the ends, giving a resultant couple or fixing moment, formula (1) may be applied to calculate the maximum intensity of pressure on the masonry. If  $b$  be the (constant) breadth of the beam and  $d$  the length of the seating,  $p_0 = \frac{R}{b \cdot d}$ . The moment of the seating pressures about the centroid of the seating is nearly the same as the bending moment at the entrance to the wall if the seating is short, exceeding it by  $R \times \frac{d}{2}$ . Taking the case of a cantilever of length  $l$  carrying an end load  $W$  (Fig. 59), the

moment is  $W\left(l + \frac{d}{2}\right)$ ; writing this for  $P \cdot h$ , and  $b \cdot d$  for  $A$ , and  $\frac{1}{6}bd^2$  for  $\frac{Ak^2}{J_1}$  in (1) or (2), the extreme intensity of pressure at the entrance to the wall is—

$$p_{\max.} = \frac{W}{bd} + \frac{6W\left(l + \frac{d}{2}\right)}{bd^2} = \frac{2W}{bd}\left(2 + \frac{3l}{d}\right)$$

which serves to calculate the maximum pressure intensity if  $d$  is known, or to determine  $d$  for a specified value (say about 500 pounds per square inch) of the working intensity of crushing stress on the seating.

EXAMPLE 1.—In a rectangular cross-section 2 inches wide and 1 inch thick the axis of a pull of 10 tons deviates from the centre of the section by  $\frac{1}{10}$  inch in the direction of the thickness, and is in the centre of the width. Find the extreme stress intensities.

The extreme bending stresses are—

$$f = \frac{M}{Z} = \frac{\frac{1}{10} \times 10}{\frac{1}{6} \times 2 \times 1} = 3 \text{ tons per square inch}$$

tension and compression along the opposite long edges of the section. To these must be added algebraically a tension of—

$$\frac{10}{2} = 5 \text{ tons per square inch}$$

hence on the side on which the pull deviates from the centroid the extreme tension is—

$$5 + 3 = 8 \text{ tons per square inch}$$

and on the opposite side the tension is—

$$5 - 3 = 2 \text{ tons per square inch}$$

Here a deviation of the load a distance of  $\frac{1}{10}$  of the thickness from the centroid increases the maximum intensity of stress to 60 per cent. over the mean value.

EXAMPLE 2.—A short cast-iron pillar is 8 inches external diameter; the metal being 1 inch thick, and carries a load of 20 tons. If the load deviates from the centre of the column by  $1\frac{3}{4}$  inches, find the extreme intensities of stress. What deviation will just cause tension in the pillar?

The area of section is  $\frac{\pi}{4}(64 - 36) = 22\cdot0$  square inches

The moment of resistance to bending is equal to—

$$20 \times 1\frac{3}{4} = 35 \text{ ton-inches}$$

hence the extreme intensities of bending stress are—

$$35 \div \frac{\pi}{32} \cdot \frac{8^4 - 6^4}{8} = \frac{35 \times 8 \times 32}{\pi \times 2800} = 1\cdot017 \text{ tons per square inch}$$

The additional compressive stress is—

$$\frac{20}{22} = 0\cdot909 \text{ ton per square inch}$$

hence the maximum compressive stress is  $1\cdot017 + 0\cdot909 = 1\cdot926$  tons per square inch, and the minimum compression is  $0\cdot909 - 1\cdot017 = -0\cdot108$ , i.e.  $0\cdot108$  ton per square inch tension.

If there is just no stress on the side remote from the eccentric load the deviation would be—

$$1.75 \times \frac{0.909}{1.017} = 1.56 \text{ inch}$$

EXAMPLE 3.—A short stanchion of symmetrical **I** section withstands a thrust parallel to its axis such that the stress would be 2 tons per square inch if the thrust were truly axial. Determine the eccentricity which would be sufficient to produce a stress of 10 tons per square inch if the section is 9 inches deep, 7 inches wide, 17.06 square inches area, the principal moments of inertia being 229.5 (inches)<sup>4</sup> and 46.3 (inches)<sup>4</sup>, the former being about an axis in the direction of the breadth.

$$\text{Taking } k_x^2 = \frac{I_x}{A} = \frac{229.5}{17.06} = 13.45 \qquad k_y^2 = \frac{46.3}{17.06} = 2.714$$

and in equation (7)  $\frac{p}{p_0} = \frac{10}{2} = 5$ ; this gives—

$$5 - 1 = 4 = \frac{4.5y}{13.45} + \frac{3.5x}{2.714}$$

$$\text{or } y = -3.854x - 11.96$$

as the locus of the centre of pressure to produce the extreme stress at one corner. The inclination of this locus to the horizontal principal axis is—

$$\tan^{-1}(-3.854) = 180 - 75.55 = 104.45^\circ$$

and for  $x = 0$ ,  $y = -11.96$  inches.

Hence the distance of the line from the centroid is—

$$11.96 \cos 75.55^\circ = 3.00 \text{ inches}$$

in a direction inclined  $14.45^\circ$  to the horizontal axis. If the centre of pressure were on the horizontal axis of the **I** section, the deviation to produce the same extreme stress would be—

$$\frac{11.96}{3.854} = 3.1 \text{ inches}$$

**99. Pillars, Columns, and Struts.**—These terms are usually applied to prismatic and similar-shaped pieces of material under compressive stress. The effects of uniformly distributed compressive stress are dealt with in Chap. II. on the supposition that the length of the strut is not great. The uniformly varying stress resulting from combined bending and compression on a short prismatic piece of material is dealt with in Arts. 97 and 98. There remain the cases in which the strut is not short, in which the strut fails under bending or buckling due to a central or to an eccentric load. Theoretical calculation for such cases is of two kinds: first, exact calculation for ideal cases which cannot be even approximately realized in practice, and secondly, empirical calculation, which cannot be rigidly based on rational theories, but which can be shown to be reasonable theoretically, as well as in a fair measure of agreement with experiments. Calculations of each kind will be dealt with in the following articles, and the objections and uncertainties attaching to each will be pointed out, but the stresses and strains produced in struts by known loads cannot be estimated

by any method with the same degree of approximation as in the case of beams or tie-rods, for reasons which will be indicated.

**100. Euler's Theory: Long Pillars.**—This refers to pillars which are very long in proportion to their cross-sectional dimensions, which are perfectly straight and homogeneous in quality, and in which the compressive loads are perfectly axially applied. Under such ideal conditions it is shown that the pillar would buckle and collapse under a load much smaller than would produce failure by crushing in a short piece of the same cross-section, and that until this critical load is reached it would remain straight. This evidently could not apply to any pillar so short that the elastic limit is reached before the buckling load.

The strength to resist buckling is greatly affected by the condition of the ends, whether fixed or free. A fixed end means one which is so supported or clamped as to constrain the direction of the strut at that point, as in the case of the ends of a built-in or encasté beam, while a free end means one which by being rounded or pivoted or hinged is free to take up any angular position due to bending of the strut. If the collapsing load for a strut with one kind of end support is found, the corresponding loads for other conditions may be deduced from it.

*Case I., Fig. 144.*—Notation as in the figure. One end O fixed, and the other end, initially at R, free to move laterally and to take up any angular position. Taking the fixed end O as origin, measuring  $x$  along the initial position of the strut OR, and bending deflections  $y$  perpendicular to OR, the bending moment at  $Q'$  is  $P(a - y)$  if the moment is reckoned positive for convexity towards the initial position OR; then, neglecting any effects of direct compression and using the relations for ordinary transverse bending, the curvature—

$$\frac{M}{EI} = \frac{P(a - y)}{EI} = \frac{d^2y}{dx^2} \quad (\text{approximately, as in Art. 77})$$

where  $I$  is the least moment of inertia of the cross-section, which is assumed to be the same throughout the length—

$$\frac{d^2y}{dx^2} + \frac{P}{EI} \cdot y = \frac{P}{EI} \cdot a \quad \dots (1)$$

The solution to this well-known differential equation is<sup>1</sup>—

$$y = a + B \cos \sqrt{\frac{P}{EI}} \cdot x + C \sin \sqrt{\frac{P}{EI}} \cdot x \quad \dots (2)$$

<sup>1</sup> See Lamb's "Infinitesimal Calculus," Art. 182.

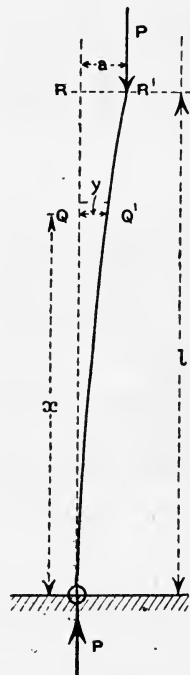

FIG. 144.

where B and C are constants of integration which may be found from the end conditions. When  $x = 0$ ,  $y = 0$ , hence—

$$0 = a + B + 0 \quad \text{or} \quad B = -a$$

And when  $x = 0$ ,  $\frac{dy}{dx} = 0$ , hence, differentiating (2)—

$$\frac{dy}{dx} = \sqrt{\frac{P}{EI}} \left( -B \sin \sqrt{\frac{P}{EI}} x + C \cos \sqrt{\frac{P}{EI}} x \right)$$

and  $0 = \sqrt{\frac{P}{EI}} (-0 + C) \quad \text{hence} \quad C = 0$

and (2) becomes—

$$y = a \left( 1 - \cos x \sqrt{\frac{P}{EI}} \right) \dots \dots \dots (2a)$$

This represents the deflection to a curve of cosines or sines, and holds for all values of  $x$  to  $x = l$ . In particular, at the free end  $x = l$  and  $y = a$ , hence—

$$a = a - a \cos l \sqrt{\frac{P}{EI}}$$

or,  $-a \cos l \sqrt{\frac{P}{EI}} = 0$

From this it follows that either  $a = 0$  or the cosine is zero. In the former case evidently no bending takes place; in the latter case, if bending takes place—

$$\cos l \sqrt{\frac{P}{EI}} = 0 \dots \dots \dots (3)$$

and  $l \sqrt{\frac{P}{EI}} = \frac{\pi}{2} \text{ or } \frac{3\pi}{2} \text{ or } \frac{5\pi}{2}, \text{ etc.}$

Taking the first value  $\frac{\pi}{2}$ , which gives the least magnitude to P—

$$l^2 \frac{P}{EI} = \frac{\pi^2}{4} \quad \text{or} \quad P = \frac{\pi^2 EI}{4l^2} \dots \dots \dots (4)$$

This gives the collapsing load, and for a long column is much within the elastic limit of compressive stress. Writing  $A \cdot k^2$  for  $I$ , where  $A$  is the constant area of cross-section and  $k$  is the least radius of gyration—

$$P = \frac{\pi^2 EA}{4} \left( \frac{k}{l} \right)^2$$

or the average intensity of compressive stress is—

$$p_0 = \frac{P}{A} = \frac{\pi^2 E}{4} \left( \frac{k}{l} \right)^2 \dots \dots \dots (5)$$

*Case II., Fig. 145.*—Both ends on pivots or frictionless hinges or otherwise free to take up any angular position. If half the length of

the strut be considered, its ends and loading evidently satisfy the conditions of Case I. ; hence the collapsing load—

$$P = \frac{\pi^2 EI}{4\left(\frac{l}{2}\right)^2} = \frac{\pi^2 EI}{l^2} \dots \dots \dots (6)$$

and 
$$\phi_0 = \frac{P}{A} = \pi^2 E \left(\frac{k}{l}\right)^2 \dots \dots \dots (7)$$

Case III., Fig. 146.—Both ends rigidly fixed in position and direction. If the length of the strut be divided into four equal parts,

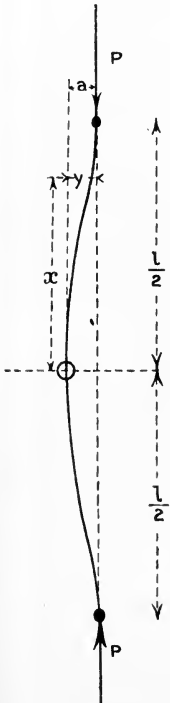

FIG. 145.

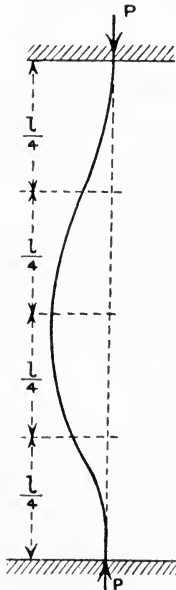

FIG. 146.

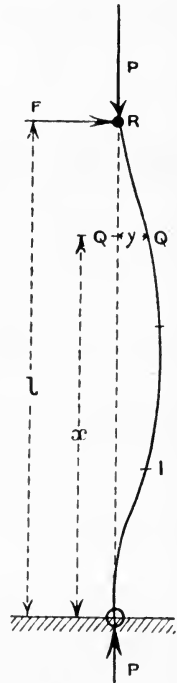

FIG. 147.

evidently each part is under the same end and loading conditions as in Case I., hence the collapsing load—

$$P = \frac{\pi^2 EI}{4\left(\frac{l}{4}\right)^2} = \frac{4\pi^2 EI}{l^2} \dots \dots \dots (8)$$

and 
$$\phi_0 = \frac{P}{A} = 4\pi^2 E \left(\frac{k}{l}\right)^2 \dots \dots \dots (9)$$

Thus the ideal strut fixed at both ends is four times as strong as one freely hinged at both ends. These two are the most important cases.

*Case IV, Fig. 147.*—One end O rigidly fixed, and the other R hinged without friction, *i.e.* free to take any angular position, but not to move laterally. Evidently, if bending takes place, some horizontal force F at the hinge will be called into play, since lateral movement is prevented there. Take O as origin. The bending moment at Q', reckoning positive those moments which tend to produce convexity towards OR, is  $F(l-x) - P \cdot y$ , hence—

$$EI \frac{d^2y}{dx^2} = F(l-x) - Py$$

$$\text{or,} \quad \frac{d^2y}{dx^2} + \frac{P}{EI} \cdot y = \frac{F}{EI}(l-x)$$

the solution of which is—

$$y = B \cos x \sqrt{\frac{P}{EI}} + C \sin x \sqrt{\frac{P}{EI}} + \frac{F}{P}(l-x). \quad (10)$$

Finding the constants as before—

$$y = 0 \text{ for } x = 0 \text{ gives } 0 = B + 0 + \frac{F}{P}l \text{ and } B = -\frac{F}{P}l$$

$$\frac{dy}{dx} = 0 \text{ for } x = 0 \text{ gives } 0 = 0 + C \sqrt{\frac{P}{EI}} - \frac{F}{P} \text{ and } C = \frac{F}{P} \sqrt{\frac{EI}{P}}$$

and substituting these values in (10)—

$$y = \frac{F}{P} \left( -l \cos x \sqrt{\frac{P}{EI}} + \sqrt{\frac{EI}{P}} \sin x \sqrt{\frac{P}{EI}} + l - x \right)$$

for all values of  $x$ . And putting  $y = 0$  for  $x = l$ —

$$0 = \frac{F}{P} \left( -l \cos l \sqrt{\frac{P}{EI}} + \sqrt{\frac{EI}{P}} \sin l \sqrt{\frac{P}{EI}} \right)$$

hence either  $F = 0$ , in which case there is no bending, or—

$$\tan l \sqrt{\frac{P}{EI}} = l \sqrt{\frac{P}{EI}}$$

an equation in  $l \sqrt{\frac{P}{EI}}$ , which may be easily solved by a table giving the values of tangents and of angles in radians. The solution for which P is least (other than  $P = 0$ ) is approximately—

$$l \sqrt{\frac{P}{EI}} = 4.5 \text{ radians}$$

$$\text{from which} \quad P = 20 \frac{1}{4} \frac{EI}{l^2} \dots \dots \dots (11)$$

$$\text{and} \quad P_0 = \frac{P}{A} = 20 \frac{1}{4} E \left( \frac{k}{l} \right)^2 \dots \dots \dots (12)$$



By substituting the known values of  $y$  in the original equation, and equating  $\frac{dy^2}{dx^2}$  to zero, we find approximately  $4.5 = \tan \frac{4.5x}{l}$ , which is satisfied by  $x = l$  or  $x = 0.30l$ , *i.e.* the point of inflection I (Fig. 147) is  $0.30l$  from 0 and  $0.70l$  (approximately) from R,  $0.35$  of the length being under conditions similar to Case I.

The ultimate strength of the strut in each case is inversely proportional to the square of its length, and comparison between the four cases above shows that the strengths are inversely proportional in Figs. 144, 145, 146, and 147 to the square of the numbers 1,  $\frac{1}{2}$ ,  $\frac{1}{4}$ , and  $0.35$  (approx.), the fraction of the lengths between a point of inflection and a point of maximum curvature. The strengths in the same order are therefore proportional to the numbers 1, 4, 16, and 8 (approx.).

**101. Use of Euler's Formulæ.**—Since actual struts deviate from many of the conditions for the ideal cases of Art. 100, the use of the formulæ there derived must be accompanied by a judicious factor to take account of such deviations, beyond the ordinary margin of a factor of safety, the effect of very small deviations from the ideal conditions being very great (see Art. 104).

*"Fixed" and "Free" Ends.*—Most actual struts will not exactly fulfil the condition of being absolutely fixed or perfectly free at the ends, and, in applying Euler's rules, allowance must be made for this. An end consisting of a broad flat flange bolted to a fairly rigid foundation will approximate to the condition of a perfectly "fixed" end, and an end which is attached to part of a structure by some form of pin-joint will approximate to the "free" condition; in other cases the ends may be so fastened as to make the strength conditions of the strut intermediate between two of the ideal cases of Art. 100, and sometimes to make the conditions different for different planes of bending.

*Elastic Failure.*—Euler's rules have evidently no application to struts so short that they fail by reaching the yield point of crushing or compressive stress before they reach the values given in Art. 100. For example, considering, say, a mild steel strut freely hinged at both ends (Case II., Art. 100), and taking  $E = 13,000$  tons per square inch, and the yield point 21 tons per square inch, the shortest length to which formula (7) could possibly apply would be such that—

$$p_0 = 21 = \pi^2 \cdot 13,000 \cdot \left(\frac{k}{l}\right)^2$$

$l$  being about 80 times  $k$ , which would be about 20 diameters for a solid circular section, and 28 diameters for a thin tube. Since these rules only contemplate very long struts, it is to be expected that they would not give very accurate values of the collapsing load until lengths considerably greater than those above mentioned have been reached. For shorter struts than these Euler's rules are not applicable, and will, if used, evidently give *much* too high a value of the collapsing load; such shorter or medium-length struts are, however, of very common occurrence in structures and machines. The values of  $p_0$  for columns of mild steel and cast iron with freely hinged ends, as calculated by (7), Art. 100, are shown in Fig. 148.

102. Rankine's and Other Empirical Formulæ.

Rankine.—For a strut so very short that buckling is practically impossible the ultimate compressive load is—

$$P_e = f_c \times A \quad \dots \dots \dots (1)$$

where A is the area of cross-section and  $f_c$  is the ultimate intensity of compressive stress, a quantity difficult to find experimentally (see Arts. 36 and 37), because in short specimens frictional resistance to lateral expansion augments longitudinal resistance to compression, and in longer specimens failure takes place by buckling;  $f_c$  may well be taken as the intensity of stress at the yield point in compression.

The ultimate load for a *very* long strut is given fairly accurately by Euler's rules (see Art. 100). Let this load be denoted by  $P_e$ ; then, taking the case of a strut free at both ends (Case II., Art. 100)—

$$P_e = \frac{\pi^2 EI}{l^2} = \pi^2 EA \left(\frac{k}{l}\right)^2 \quad \dots \dots \dots (2)$$

If P is the crippling load of a strut of *any* length  $l$  and cross-section A, the equation—

$$\frac{1}{P} = \frac{1}{P_e} + \frac{1}{P_c} \quad \dots \dots \dots (3)$$

evidently gives a value of P which holds well for a very short strut, for  $\frac{1}{P_c}$  then becomes negligible, or  $P = P_e$  very nearly, and also holds for a very long strut, for  $\frac{1}{P_e}$  then becomes negligible in comparison with  $\frac{1}{P_c}$  and  $P = P_c$  very nearly. Further, since the change in P caused by increasing  $l$ , for a constant value of A, must be a continuous change, it is reasonable to take (3) as giving the value of P for any length of strut.

For a strut with both ends free, the equation (3) may be written—

$$P = \frac{1}{\frac{1}{f_c \cdot A} + \frac{l^2}{\pi^2 EI}} = \frac{f_c A}{1 + \frac{f_c \cdot l^2}{\pi^2 E k^2}} = \frac{f_c \cdot A}{1 + a \left(\frac{l}{k}\right)^2} \quad \dots (4)$$

where  $a = \frac{f_c}{\pi^2 E}$ , a constant for a given material, or if  $p_0$  is the mean intensity of compressive stress on the cross-section—

$$p_0 = \frac{P}{A} = \frac{f_c}{1 + a \left(\frac{l}{k}\right)^2} \quad \dots \dots \dots (5)$$

In the case of a strut "fixed" at both ends the constant is  $\frac{a}{4}$ , and for a strut fixed at one end with angular freedom at the other it is  $\frac{a^1}{2}$

<sup>1</sup>  $\frac{a}{2}$  is simpler and more correct than the value  $\frac{4}{9}a$  often given (see Case IV. Art. 100).

(approximately), and for a strut fixed at one end and free to move in direction and position at the other it is  $4a$  (see Cases III., IV., and I., Art. 100). The above are Rankine's rules for struts; they are really empirical, and give the closest agreement with experiments on a series of struts of different ratios  $\frac{l}{k}$  when the constants are determined from such experiments rather than from the values of  $E$  and  $f_c$  for a short length. The values  $f$  and  $\frac{f_c}{\pi^2 E}$  of the constants in (4) may be called the "theoretical" constants; the value of  $a$  would evidently be less than  $\frac{f_c}{\pi^2 E}$  for ends with hinges which are not frictionless, and which consequently help to resist bending.

*Gordon's Rule.*—Rankine's rule is a modification of an older rule of Gordon's, viz.—

$$P = \frac{f_c \cdot A}{1 + c \left(\frac{l}{d}\right)^2} \dots \dots \dots (6)$$

where  $d$  is the least breadth or diameter of the cross-section in the direction of the least radius of gyration, and  $c$  is a constant which will differ not only for different materials and end fixings, but with the shape of cross-section, its relation to Rankine's constant  $a$  being—

$$\frac{c}{d^2} = \frac{a}{k^2} \quad \text{or} \quad c = a \left(\frac{d}{k}\right)^2$$

e.g. in a solid circular section of radius  $R$ ,  $d = 2R$ ,  $k = \frac{R}{2}$ , and  $c = 16a$ .

"Rational" derivations of Rankine's and Gordon's formulæ have often been given, but they depend on the inexact assumptions that since the deflection of a beam under purely transverse loads is directly proportional to the square of the length within the elastic limit, the same is true of deflections resulting from end loads and beyond the elastic limit.

*Rankine's Constants.*—The usually accepted values of  $f_c$  and  $a$  in Rankine's formula are about as follow:—

Material.	$f_c$ tons per square inch.	$a$
Mild steel . . . . .	21	$\frac{1}{7500}$
Wrought iron . . . . .	16	$\frac{1}{9000}$
Cast iron . . . . .	36	$\frac{1}{1500}$

The above constants for wrought and cast iron are those given as average values by Rankine and widely adopted. The value of  $f_c$  for mild steel taken as the yield point may be rather lower than that given above, and rather higher for many kinds of machinery steel, the value of  $a$  being altered in about the same proportion. The values of  $p$

obtained from Rankine's formula (5) with the above constants will generally be rather above the values of Euler's "ideal" strut, and therefore obviously too high; for very long columns with absolutely free ends, because the values of  $a$  (generally deduced from experiments in which the ends are not absolutely free) are smaller than the "theoretical" value  $\frac{f_0}{\pi^2 E}$ . The average intensities of stress, or load per unit area of cross-section, occurring at the ultimate loads for mild steel and cast-iron struts of various lengths with free ends, as calculated by Rankine's formula, and the above constants, are shown in Fig. 148.

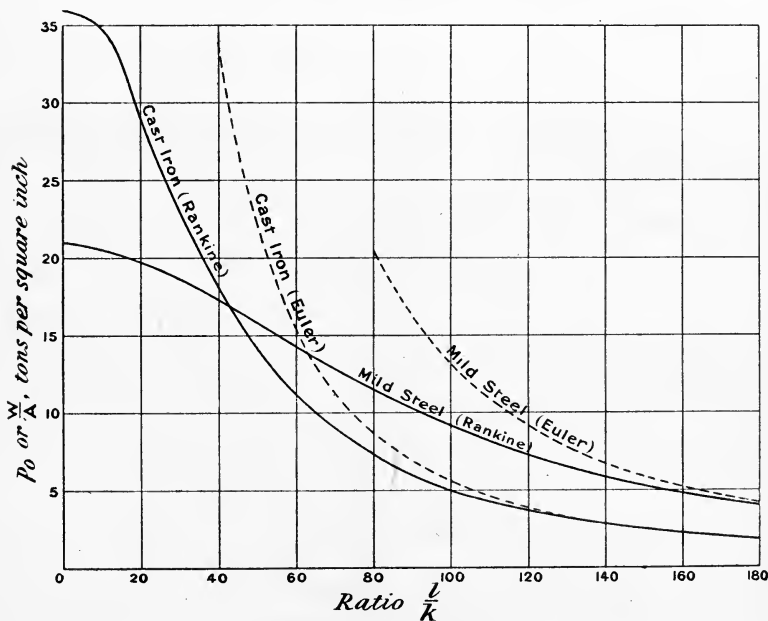

FIG. 148.—Ultimate strength of struts.

*Choice of a Formula.*—If the ratio  $\frac{l}{k}$  exceeds about 150, Euler's values may be used to give the breaking loads, and factors of safety on the average intensity of stress of 5 for steel and wrought iron, 6 for cast iron, and 10 for timber may be used to give the working loads. For shorter struts Rankine's formula may be used with factors of safety of about 3 or 4 for steel.

It may be noted that the specifications of the American Bridge Co. for dead loads give the permissible loads in pounds per square inch of cross-section, as—

$$p = \frac{15,000}{1 + \frac{1}{13,500} \left(\frac{l}{k}\right)^2} \quad (\text{for soft steel})$$

and

$$p = \frac{17,000}{1 + \frac{1}{11,000} \left(\frac{l}{k}\right)^2} \quad (\text{for medium steel})$$

where  $l$  is the length of a structural strut centre to centre of the pins at its ends.

Euler's formula, for cases in which it may reasonably be used, has the advantage of directness; the necessary area of cross-section may be found for a given load from (4), (6), (8), or (11), Art. 100.

Rankine's formula, like all others except Euler's, while quite convenient for finding the working or the ultimate load for a given area, and shape of cross-section, is not very direct for finding the dimensions of cross-section in order to carry a given load; it leads to a quadratic equation in the square of some dimension.

*Johnson's Parabolic Formula.*—Johnson has adopted an empirical formula—

$$p_0 = f_c - b \left(\frac{l}{k}\right)^2 \dots \dots \dots (7)$$

which, when plotted on a base-line giving values of  $\frac{l}{k}$ , is a parabola,  $f_c$  is the yield point in compression, and  $b$  is a constant determined so as to make the parabola meet the curve plotted with Euler's values of  $p_0$  tangentially. For a strut absolutely "free" at the ends this condition makes  $b = \frac{f_c^2}{4\pi^2 E}$ , and, owing to friction, Johnson adopts the

smaller values of about  $\frac{f_c^2}{64 E}$  for pin ends and  $\frac{f_c^2}{100 E}$  for flat ends. For

values of  $\frac{l}{k}$  beyond the point of tangency with Euler's curve, Euler's values of  $p_0$  must be adopted, and to allow for the frictional resistance to bending offered by pin or flat ends, (7) of Art. 100 is modified to  $16E\left(\frac{k}{l}\right)^2$  and  $25E\left(\frac{k}{l}\right)^2$  respectively, these values of  $p_0$  being based on experimental results. The form of Johnson's formula is a trifle more convenient than that of Rankine's.

**103. Comparison with Experiments.**—A great many experimental determinations of the ultimate strength of struts have been made under various conditions, a list of references to which will be found at the end of the present chapter, and various empirical formulæ have been devised to suit the various results. The results have been most consistent, and in agreement with empirical algebraic formulæ, as might be expected, when the conditions of loading and fixing have approached most nearly to the ideal, but, on the other hand, such conditions do not correspond to those for the practical strut, as used in machines and structures, which deviate from the ideal in want of straightness and homogeneity of material, more or less eccentricity of the thrust, and in the conditions of freedom or fixture at the ends. The results of tests obtained for struts under more or less working conditions show great variations,

and no formula, empirical or otherwise, can more than roughly predict the load at which failure will take place in a given case.<sup>1</sup> This being so, for design purposes one empirical formula is generally about as accurate as another, and the simplest is the best form to use, the constants in any case being deduced from a (short) range of values of  $\frac{l}{k}$ , within limits for which experimental information is available; for example, straight-line formulæ of the type—

$$p_0 = f - \left( \text{constant} \times \frac{l}{k} \right)$$

where  $p_0$  is the load per unit area of cross-section and  $f$  is a constant, may be used to give the working or the breaking-stress intensities over short ranges of  $\frac{l}{k}$ .

Experiments always show that flexure of struts intended to be axially loaded begins at loads much below the maximum ultimately borne, this being due to eccentricity and other variations from the premises upon which Euler's and Rankine's rules depend. This leads us to consider in the next article the effect of eccentric loading on a long column where the flexure is not negligible (as it is in a very short one), and where the greatest bending moment is mainly from the increased eccentricity which results from flexure.

EXAMPLE 1.—A mild-steel strut hinged at both ends has a T section, the area being 3.634 square inches, and the least moment of inertia is 4.70 (inches)<sup>4</sup>. Find, by Rankine's formula, the crippling load of the strut, which is 6 feet long, if the ultimate crushing strength is taken at 21 tons per square inch.

The square of the least radius of gyration is  $\frac{4.7}{3.634} = 1.293$  (inches)<sup>2</sup>—

$$\left( \frac{l}{k} \right)^2 = \frac{72 \times 72}{1.293} = 4000$$

Using the constant given in the text, viz.  $\frac{1}{7500}$ ; for this case—

$$P = \frac{3.634 \times 21}{1 + \frac{4000}{7500}} = \frac{15}{23} \times 3.634 \times 21 = 49.7 \text{ tons}$$

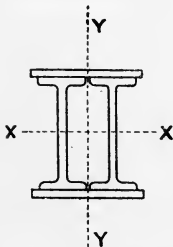

EXAMPLE 2.—A steel stanchion of the form shown in Fig. 149 has a cross-sectional area of 39.88 square inches, and its least radius of gyration is 3.84 inches. Both ends being fixed, and the length being 40 feet, find its crippling load, (1) by Euler's formula, (2) by Rankine's formula. ( $E = 13,000$  tons per square inch.)

By Euler's formula—

$$P = \frac{4\pi^2 \times 13,000 \times 39.88 \times (3.84)^2}{480 \times 480} = 1307 \text{ tons}$$

<sup>1</sup> References to experimental researches, numerical straight line formula, forms and proportions of built-up struts are given in the Author's "Theory of Structures."

By Rankine's formula, and the constants given—

$$P = \frac{21 \times 39.88}{1 + \frac{480 \times 480}{3.84 \times 3.84 \times 30,000}} = \frac{21 \times 39.88}{1.520} = 551 \text{ tons}$$

EXAMPLE 3.—Find the necessary thickness of metal in a cast-iron column of hollow circular section, 20 feet long, fixed at both ends, the outside diameter being 8 inches, if the axial load is to be 80 tons, and the crushing load is to be 6 times this amount.

Let  $d$  be the necessary internal diameter in inches.

The sectional area is  $\frac{\pi}{4}(8^2 - d^2)$ , and  $I = \frac{\pi}{64}(8^4 - d^4)$ , hence  $k^2 = \frac{1}{16}(8^2 + d^2)$ .

The breaking load being 480 tons, Rankine's formula, with the constants given in Art. 102, becomes—

$$480 = \frac{36 \times \frac{\pi}{4}(8^2 - d^2)}{1 + \frac{240 \times 240 \times 16}{6400(8^2 + d^2)}} = \frac{9\pi(8^4 - d^4)}{208 + d^2}$$

$$d^4 + 17d^2 - 560 = 0$$

$$d^2 = 16.65 \quad d = 4.08''$$

Thickness of metal =  $\frac{8 - 4.08}{2} = 1.96$ , or nearly 2 inches.

104. Long Columns under Eccentric Load.—As Euler's formulæ are only strictly applicable to struts absolutely axially loaded, it is interesting to find what modifications follow if there is an eccentricity  $h$  at the points of application of the load. Variation of elasticity of the material and initial curvature of the strut must give a similar effect, and may be looked upon as an increased value of  $h$ . Taking Case I., Art. 100, if  $P$  is applied at a distance  $h$  from the centre at  $R'$  Fig. 144 (and on the principal axis perpendicular to that about which the minimum value  $I$  is taken), the bending moment at  $Q'$  will be  $P(a + h - y)$ , and (1), Art. 100, becomes—

$$\frac{d^2 y}{dx^2} + \frac{P}{EI} \cdot y = \frac{P}{EI}(a + h) \dots \dots (1)$$

and the solution (2a) of Art. 100 becomes—

$$y = (a + h)\left(1 - \cos x \sqrt{\frac{P}{EI}}\right) \dots \dots (2)$$

and at  $x = l$  this becomes—

$$y = a = (a + h)\left(1 - \cos l \sqrt{\frac{P}{EI}}\right)$$

$$a \cos l \sqrt{\frac{P}{EI}} = h\left(1 - \cos l \sqrt{\frac{P}{EI}}\right)$$

$$a = h\left(\sec l \sqrt{\frac{P}{EI}} - 1\right) \dots \dots (3)$$

The eccentricity of loading at the origin O is—

$$a + h = h \sec l \sqrt{\frac{P}{EI}} \dots \dots \dots (4)$$

the bending moment there being increased  $\sec l \sqrt{\frac{P}{EI}}$  times due to flexure. The bending moment at O is  $P(a + h) = Ph \sec l \sqrt{\frac{P}{EI}}$ , which, so long as the intensity of stress is proportional to the strain, causes in a symmetrical section equal and opposite bending stresses of intensity—

$$p_b = \frac{Ph}{Z} \sec l \sqrt{\frac{P}{EI}} = \frac{Phd}{2I} \sec l \sqrt{\frac{P}{EI}}$$

where  $d$  is the depth of section in the plane of bending, *i.e.* in the direction of the least radius of gyration; if the section is unsymmetrical,  $y_c$  and  $y_t$  must be used instead of  $\frac{d}{2}$  (see Art. 63); hence the greatest compressive stress  $p$ , by (1), Art. 97, is—

$$p = \frac{P}{A} + \frac{Phd}{2k^2A} \sec l \sqrt{\frac{P}{EI}} = \frac{P}{A} \left( 1 + \frac{hd}{2k^2} \sec l \sqrt{\frac{P}{EI}} \right) \dots (5)$$

which becomes infinite, as in Art. 100, when—

$$l \sqrt{\frac{P}{EI}} = \frac{\pi}{2} \quad \text{or} \quad P = \frac{\pi^2 EI}{4l^2}$$

Also 
$$\frac{P}{A} = \frac{p}{1 + \frac{hd}{2k^2} \sec l \sqrt{\frac{P}{EI}}} \dots \dots (6)$$

and if  $f_c$  is the crushing strength of the material, *i.e.* say the stress intensity at the yield point in compression, at failure by buckling—

$$p_0 = \frac{P}{A} = \frac{f_c}{1 + \frac{hd}{2k^2} \sec l \sqrt{\frac{P}{EI}}} \dots \dots \dots (7)$$

In the case of a column free at both ends (Case II., Art. 100, and Fig. 145), with an eccentricity  $h$  of the thrust at the ends, by writing  $\frac{l}{2}$  instead of  $l$ , (4) becomes—

$$(a + h) = h \sec \frac{l}{2} \sqrt{\frac{P}{EI}} \dots \dots \dots (8)$$

and (5) becomes—

$$p = \frac{P}{A} \left( 1 + \frac{hd}{2k^2} \sec \frac{l}{2} \sqrt{\frac{P}{EI}} \right) \dots \dots \dots (9)$$



and at failure by compressive yielding (7) becomes—

$$p_0 = \frac{P}{A} = \frac{f_c}{1 + \frac{hd}{2k^2} \sec \frac{l}{2} \sqrt{\frac{P}{EI}}} = \frac{f_c}{1 + \frac{hd}{2k^2} \sec \frac{l}{2} \sqrt{\frac{p_0}{k^2 E}}} \quad (10)$$

Allowing for a slight difference of notation, when  $l = 0$ , (5) and (9) reduce to the form (1) of Art. 98, the increase of bending stress due to flexure being only important when the length is considerable.

If failure occurs by tension, as is usual in cast iron, the greatest intensity of tensile stress corresponding to (9) is—

$$p = \frac{P}{A} \left( \frac{hd}{2k^2} \sec \frac{l}{2} \sqrt{\frac{P}{EI}} - 1 \right) \dots \dots (11)$$

and if  $f_t$  is the limit of tensile-stress intensity at fracture, instead of (10) at failure by *tension* the average *compressive* stress is—

$$p_0 = \frac{P}{A} = \frac{f_t}{\frac{hd}{2k^2} \sec \frac{l}{2} \sqrt{\frac{P}{EI}} - 1} = \frac{f_t}{\frac{hd}{2k^2} \sec \frac{l}{2} \sqrt{\frac{p_0}{k^2 E}} - 1} \quad (12)$$

From equations (9) and (11) the extreme intensities of compressive and tensile stress may be found for a strut with given dimensions, load, and eccentricity, or the eccentricity which will cause any assigned intensity of stress may be found.

It is evident that  $p$  becomes infinite for  $P = \frac{\pi^2 EI}{l^2}$ , just as in Euler's theory, where the eccentricity  $h = 0$ ; but these equations show that where  $h$  is not zero,  $p$  approaches the ultimate compressive or tensile strengths for values of  $P$  much below Euler's critical values. The reader will find it instructive to plot the values of  $P$  and  $p$  for any given section, and for several different magnitudes of the eccentricity  $h$ , and to observe how  $p$  increases with  $P$  in each case.

For a strut of given dimensions with given eccentricity  $h$ , the ultimate load  $P$  (or  $p_0$ ) to satisfy equations (10) or (12) for a given ultimate stress intensity  $f_c$  or  $f_t$  may be found by trial or by plotting as ordinates the difference of the two sides of either equation, on a base-line of values of  $P$ , and finding for what value of  $P$  the ordinate is zero. It is convenient to write  $\frac{l}{2} \sqrt{\frac{P}{EI}} = \frac{\pi}{2} \sqrt{\frac{P}{P_0}}$  where  $P_0 = \frac{\pi^2 EI}{l^2}$  when solving for  $P$  by trial, the angle in degrees being  $90 \sqrt{\frac{P}{P_0}}$ .

Fig. 150 shows the ultimate values of  $p_0$  for mild-steel struts of circular section and various lengths, taking  $f_c = 21$  tons per square inch with various degrees of eccentricity. It shows that for struts about 20 diameters in length, for example, an eccentricity of  $\frac{1}{100}$  of the diameter greatly decreases the load which the ideal strut would support.

Also that when there is an eccentricity of  $\frac{1}{10}$  of the diameter an additional eccentricity of  $\frac{1}{100}$  of the diameter does not greatly reduce the strength.

To find the dimensions of cross-section for a strut of given length, load and eccentricity, and shape of cross-section, in order not to exceed a fixed intensity of stress  $f_c$  or  $f_b$ , the above equations may be solved by trial or plotting if  $A$  and  $k$  (or  $I$ ) are put in terms of  $d$ , viz.  $A = c_1 \times d^2$ ,

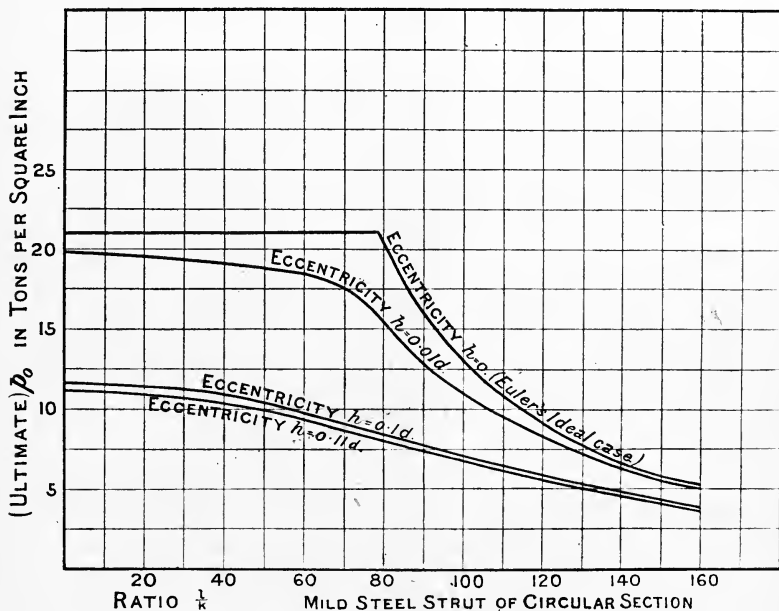

FIG. 150.—Eccentric loading of struts.

$k^2 = c_2 \times d^2$  (or  $I = c_3 \times d^4$ ), where  $c_1$  and  $c_2$  (or  $c_3$ ) are constants depending on the shape of cross-section. In solving by trial a first approximation to the unknown quantity may be found by taking the secant as unity, as in Art. 98; the further adjustment of the result is then simple. Prof. R. H. Smith<sup>1</sup> has shown how, where a large number of such problems are to be solved, the calculation may be facilitated by drawing a series of curves corresponding to various degrees of eccentricity and adaptable to any shape of section.

It may be noticed from equations (9) and (10) that with increase of load  $P$  the maximum intensity of stress is increased more than proportionally, because the part due to bending increases with the increased eccentricity due to flexure as well as with the increased load. Hence the ratio of the ultimate or crippling loads to any working load will be less than the factor of safety, as understood by the ratio of the maximum intensity of stress to the ultimate intensity of crushing stress

<sup>1</sup> See the *Engineer*, October 14 and 28, and November 25, 1887.

(at the yield point, say). This point is illustrated in Examples Nos. 3 and 4 at the end of the present article.

In the case of a long tie-rod with an eccentric load the greatest intensities of stress are at the end sections, where the eccentricity is  $h$ ; in the centre it is only  $h \operatorname{sech} \frac{l}{2} \sqrt{\frac{P}{EI}}$ .

*Approximate Method.*<sup>1</sup>—Professor Perry has shown that the trigonometrical function  $\sec \frac{l}{2} \sqrt{\frac{P}{EI}}$  (or  $\sec \frac{\pi}{2} \sqrt{\frac{P}{P_e}}$ , where  $P_e = \frac{\pi^2 EI}{l^2}$ , Euler's critical value of  $P$  when  $h = 0$ ) may be replaced approximately by the algebraic function—

$$\frac{1.2}{1 - \frac{P}{P_e}} \quad \text{or} \quad \frac{1.2}{1 - \frac{Pl^2}{\pi^2 EI}}$$

the factor 1.2 being about an average value applicable over the range  $\frac{P}{P_e} = 0.5$  to  $0.9$ , which errs on the side of safety for working loads; for  $\frac{P}{P_e} = \frac{1}{5}$ , which is about a usual working load for a strut, the constant is 1.05. Making this substitution, (9) becomes—

$$p = \frac{P}{A} \left( 1 + \frac{\frac{1.2hd}{2k^2}}{1 - \frac{Pl^2}{\pi^2 EI}} \right) \dots \dots \dots (13)$$

which may most neatly be written—

$$\left( \frac{pA}{P} - 1 \right) \left( 1 - \frac{P}{P_e} \right) \quad \text{or} \quad \left( \frac{p}{p_0} - 1 \right) \left( 1 - \frac{p_0 l^2}{\pi^2 E k^2} \right) = 0.6 \frac{hd}{k^2} \quad (14)$$

and (11) becomes—

$$p = \frac{P}{A} \left( \frac{\frac{1.2hd}{2k^2}}{1 - \frac{Pl^2}{\pi^2 EI}} - 1 \right) \dots \dots \dots (15)$$

which reduces to—

$$\left( \frac{pA}{p} + 1 \right) \left( 1 - \frac{P}{P_e} \right) \quad \text{or} \quad \left( \frac{p}{p_0} + 1 \right) \left( 1 - \frac{p_0 l^2}{\pi^2 E k^2} \right) = 0.6 \frac{hd}{k^2} \quad (16)$$

As before, from (14) and (16) the extreme intensities of stress may be found for a strut of known dimensions carrying a known load with any assigned eccentricity; or the allowable eccentricity may be calculated for a given limit of the tensile or compressive-stress intensity. Also for

<sup>1</sup> See the *Engineer*, December 10 and 24, 1886. A more accurate and equally simple approximation is given in the Author's "Theory of Structures."

a strut of given dimensions, and maximum safe intensity of stress with a given eccentricity, the load  $P$  may be calculated directly as the root of the quadratic equation (14) or (16), according as the specified stress limit is compressive ( $p = f_c$ ) or tensile ( $p = f_t$ ).

The dimensions of cross-section for a strut of given length and shape to carry a given load, with given eccentricity and a given stress limit, may be found by taking, as before,  $A = c_1 \cdot d^2$ ,  $k^2 = c_2 \cdot d^2$ ,  $I = c_3 \cdot d^4 = c_1 \cdot c_2 \cdot d^4$ , where  $c_1$  and  $c_2$  are constants, in (14) or (16). Since  $P_e$  is proportional to  $d^4$ , these equations evidently become sextic (or sixth-power) equations in  $d$ , and (14) or (16) being used according as the specified limit of stress intensity is compressive or tensile,  $d$  may be found by trial or plotting. For a solution by trial a first approximation may be obtained by taking  $l = 0$  when equation (14) reduces to the form of (1), Art. 98. If  $h$  should be specified as a fraction of  $d$ , the equation will reduce to a cubic in  $d^2$ .

The approximate solution may be tested by the more exact rules (10) and (12), and adjusted to satisfy them.

Assuming any initial curvature of a strut to be of the form of a curve of cosines, Prof. Perry, in the paper referred to above, shows that initial curvature is equivalent to eccentricity not greatly different from the maximum deflection of the strut at the centre from its proper position of straightness. This may be verified by substituting  $h_1 \cos \frac{\pi x}{2l}$

for  $h$  in (1), the conditions being  $y = 0$  and  $\frac{dy}{dx} = 0$  for  $x = 0$  and  $y = a$  for  $x = l$ ; the maximum bending moment is then  $P(a + h_1)$ , which is equal to—

$$\frac{Ph_1}{1 - \frac{P}{P_e}}$$

where  $P_e = \frac{\pi^2 EI}{4l^2}$ . A similar value holds for other cases when the value of  $P_e$  is modified as in Art. 100.

EXAMPLE 1.—A cast-iron pillar is 8 inches external diameter, the metal being 1 inch thick, and carries a load of 20 tons. If the column is 40 feet long and rigidly fixed at both ends, find the extreme intensities of stress in the material if the centre of the load is  $1\frac{3}{4}$  inch from the centre of the column. What eccentricity would be just sufficient to cause tension in the pillar? ( $E = 5000$  tons per square inch.) The corresponding problem for a very short column has been worked in Ex. 2, Art. 98, and these results may be used—

$$p_0 = 0.909 \text{ ton per square inch} \quad k^2 = \frac{1}{16}(8^2 + 6^2) = \frac{25}{4}$$

The bending stress is increased in the ratio  $\sec \frac{l}{4} \sqrt{\frac{P}{EI}}$  or

$$\sec \frac{l}{4} \sqrt{\frac{p_0}{Ek^2}} = \sec \frac{480}{4} \sqrt{\frac{0.909 \times 4}{5000 \times 25}} = \sec 0.646 = \sec 37^\circ = 1.25.$$

Hence the bending-stress intensity is—

$$1.017 \times 1.25 = 1.27 \text{ ton per sq. in.}$$

The maximum compressive stress =  $1.27 + 0.909 = 2.18$  tons per sq. in.

The maximum tensile stress =  $1.27 - 0.909 = 0.36$  ton per sq. in.

or more than treble that when there is no flexure increasing the eccentricity.

If the eccentricity is just sufficient to cause tension in the pillar, its amount is—

$$1.75 \times \frac{0.909}{1.27} = 1.25 \text{ inch}$$

EXAMPLE 2.—A compound stanchion has the section shown in Fig. 149; its radius of gyration about YY is 3.84 inches, and its breadth parallel to XX is 14 inches. The stanchion, which is to be taken as free at both ends, is 32 feet long. If the load per square inch of section is 4 tons, how much may the line in which the resultant force acts at the ends deviate from the axis YY without producing a greater compressive stress than 6 tons per square inch, the resultant thrust being in the line XX? How much would it be in a very short pillar? ( $E = 13,000$  tons per square inch.)

Evidently from (9) the bending-stress intensity must be  $6 - 4 = 2$  tons per square inch; hence, if  $h$  is the eccentricity—

$$\begin{aligned} \frac{hd}{2k^2} \sec \frac{l}{2} \sqrt{\frac{p_0}{Ek^2}} &= 2 \\ \frac{4 \cdot h \cdot 14}{2 \times (3.84)^2} \sec \frac{192}{3.84} \sqrt{\frac{4}{13,000}} &= 2 \\ h(1.897 \sec 50.3^\circ) &= 2.97h = 2 \\ h &= 0.675 \text{ inch} \end{aligned}$$

For a very short pillar where the flexure is negligible this would evidently be—

$$h \times 1.897 = 2 \quad h = 1.055 \text{ inch}$$

the equation reducing to the form (1), Art. 98, since the secant is practically unity.

It is interesting to compare the solution by (14)—

$$\begin{aligned} \left(\frac{6}{4} - 1\right) \left(1 - \frac{10,000 \times 4}{13,000\pi^2}\right) &= 0.6 \times \frac{14}{14.75} \times h \\ h &= 0.605 \text{ inch} \end{aligned}$$

This is less than the previous result, because the factor 1.2 introduced in (13) is too great for an average stress so much below the ultimate value; without the factor the approximate method would give a value 20 per cent. higher, *i.e.*  $h = 0.726$ , which is too large, and errs on the wrong side for safety.

EXAMPLE 3.—Find the load per square inch of section which a

column of the cross-section given in Ex. 2 will carry with an eccentricity of  $1\frac{1}{2}$  inch from XX, the column being 28 feet long and free at both ends, the maximum compressive stress not exceeding 6 tons per square inch. Find also the ultimate load per square inch of section if the ultimate compressive strength is 21 tons per square inch. ( $E = 13,000$  tons per square inch.)

Using first the approximate method, (14) gives—

$$\left(\frac{6}{p_0} - 1\right) \left\{ 1 - \frac{p_0}{\pi^2 \times 13,000} \left(\frac{28 \times 12}{3.84}\right)^2 \right\} = \frac{3}{5} \times \frac{3}{2} \cdot \frac{14}{(3.84)^2}$$

$$(6 - p_0)(1 - 0.059p_0) = 0.858p_0$$

or,

$$p_0^2 - 37.3p_0 + 102 = 0$$

hence

$$p_0 = 2.95 \text{ tons per square inch}$$

Testing this value in (9)—

$$2.95 \left( 1 + \frac{3}{2} \times \frac{14}{2 \times 14.75} \sec \frac{168}{3.84} \sqrt{\frac{2.95}{13,000}} \right) \\ = 2.95 (1 + 0.715 \sec 37.8^\circ) = 5.62 \text{ tons per square inch}$$

instead of 6, hence 2.95 is rather too low. Trial shows that—

$$p_0 = 3.12 \text{ tons per square inch}$$

satisfies (9), and is the allowable load per square inch of section. Substituting 21 tons per square inch for 6 in the above work gives 8.2 tons per square inch of section as the crippling load. Note that while the factor of safety reckoned on the stress is  $\frac{21}{6} = 3\frac{1}{2}$ , the ratio of ultimate to working load is  $\frac{8.2}{3.12} = 2.63$ .

EXAMPLE 4.—A steel strut is to be of circular section, 50 inches long and hinged at both ends. Find the necessary diameter in order that, if the thrust of 15 tons deviated at the ends by  $\frac{1}{10}$  of the diameter from the axis of the strut, the greatest compressive stress shall not exceed 5 tons per square inch. If the yield point of the steel in compression is 20 tons per square inch, find the crippling load of the strut. ( $E = 13,000$  tons per square inch.)

$$k = \frac{d}{4} \quad A = \frac{\pi d^2}{4} \quad h = \frac{d}{10}$$

Using the approximate equation (14)—

$$\left(\frac{5\pi d^2}{4 \times 15} - 1\right) \left(1 - \frac{15 \times 64 \times 2500}{\pi^2 \times 13,000 \times \pi d^4}\right) = 0.6 \times \frac{d}{10} \times \frac{d \times 16}{d^2} = 0.96$$

$$(0.2616d^2 - 1) \left(1 - \frac{5.88}{d^4}\right) = 0.96$$

$$d^6 - 7.5d^4 - 5.88d^2 + 22.5 = 0$$

a cubic equation in  $d^2$ , which by trial gives—

$$d^2 = 7.9$$

$$d = 2.81 \text{ inches}$$

Testing this result by equation (9)—

$$\frac{15 \times 4}{\pi \times 7.9} \left(1 + \frac{16}{20} \sec 0.484\right) = 4.58$$

instead of 5 tons per square inch.

By trial  $d = 2.7$  inches nearly.

Taking this value for failure when  $p = 20$  tons per square inch, (14) gives—

$$\left(\frac{20}{p_0} - 1\right) \left(1 - \frac{5500p_0}{128,000}\right) = 0.96$$

$$p_0 = 8.15 \text{ tons per square inch}$$

and by trial, from (9)—

$$p_0 = 8.43 \text{ tons per square inch}$$

the whole load on the strut being—

$$8.43 \times \frac{\pi}{4} \times (2.7)^2 = 48.4 \text{ tons}$$

Thus the factor of safety reckoned on the greatest intensity of stress is  $\frac{20}{8} = 2.5$ , but the ratio of crippling load to working load is  $\frac{48.4}{15} = 3.22$ .

**105. Struts and Tie-rods with Lateral Loads.**—When a prismatic piece of material is subjected to axial and lateral forces it may be looked upon as a beam with an axial thrust or pull, or as a strut or tie-rod with lateral bending forces. The stress intensity at any cross-section is, as indicated by (1), Art. 97, the algebraic sum of the bending stress, and the direct stress which the axial thrust would cause if there were no lateral forces.

In a beam which is only allowed a very limited deflection, *i.e.* which is not very long in proportion to its dimensions of cross-section, the bending stress may usually be taken as that resulting from the transverse loads only. If, however, the beam is somewhat longer in proportion to its cross-section, the longitudinal force, which may be truly axial only at the ends, will cause a considerable bending stress due to its eccentricity elsewhere, and will play an appreciable part in increasing or decreasing the deflection produced by the lateral load, according as it is a thrust or a pull. In this case, the bending stresses at any section are the algebraic sum of those produced by the transverse loads, and those produced by the eccentricity of the longitudinal forces. Unless the bar is very long, or the longitudinal force is very great, a fairly close approximation to the bending moment may be found by taking the algebraic sum of that resulting from the transverse forces and that resulting from the eccentricity of the longitudinal force, on the assumption that the deflection or eccentricity is that due to the transverse loads only. The solution of a problem under these approximations has already been dealt with, the bending stress due to transverse loads being as calculated in Chapters IV. and V., the deflection being as calculated in Chapter VI., and the stresses resulting from the eccentric longitudinal force being calculated as

in Art. 98. It remains to deal with those cases where the end thrust or pull materially affects the deflection, and where consequently the above approximation is not valid; this is the work of the two following articles, which give the stress intensities for members of any proportion, and indicate the circumstances under which the simpler solution of the problem will be approximately correct.

**106. Strut with Lateral Load.**—Let  $l$  be the length of a uniform strut freely hinged at each end and carrying a load  $w$  per unit length. Let the end thrust which passes through the centroid of the cross-section at each end be  $P$ . Take the origin  $O$  (Fig. 151) midway between the ends, the line joining the centroids of the ends being the

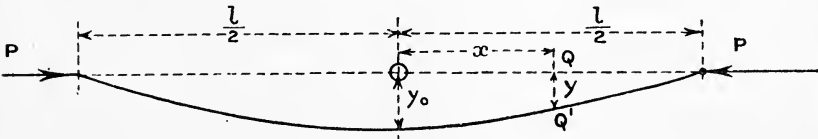

FIG. 151.

axis of  $x$ . The bending moment at  $Q'$  is  $\frac{w}{2}(\frac{l^2}{4} - x^2)$  due to the lateral load and  $P \cdot y$  due to the end thrust  $P$ . Since each tends to cause concavity towards the initial position of the strut, the sum is equal to  $-EI \frac{d^2y}{dx^2}$  where  $I$  is the (constant) moment of inertia of the cross-section about an axis through its centroid and perpendicular to the plane of flexure, or—

$$EI \frac{d^2y}{dx^2} = -\frac{w}{2}(\frac{l^2}{4} - x^2) - P \cdot y \dots \dots \dots (1)$$

$$\frac{d^2y}{dx^2} + \frac{P}{EI} \cdot y = -\frac{w}{2EI}(\frac{l^2}{4} - x^2) \dots \dots \dots (2)$$

The solution to this equation is—

$$y = \frac{w}{2P}x^2 - \frac{wl^2}{8P} - \frac{wEI}{P^2} + A \cos \sqrt{\frac{P}{EI}}x + B \sin \sqrt{\frac{P}{EI}}x \dots (3)$$

and the conditions  $\frac{dy}{dx} = 0$  for  $x = 0$  and  $y = 0$  for  $x = \frac{l}{2}$  give—

$$B = 0 \quad A = \frac{wEI}{P^2} \sec \frac{l}{2} \sqrt{\frac{P}{EI}}$$

$$\text{hence } y = \frac{w}{2P}x^2 - \frac{wl^2}{8P} - \frac{wEI}{P^2} \left( 1 - \sec \frac{l}{2} \sqrt{\frac{P}{EI}} \cos \sqrt{\frac{P}{EI}}x \right) \dots (4)$$

and at the origin—

$$y_0 = -\frac{wl^2}{8P} - \frac{wEI}{P^2} \left( 1 - \sec \frac{l}{2} \sqrt{\frac{P}{EI}} \right) \dots \dots (5)$$



and the maximum bending moment at O is—

$$-M_0 = P \cdot y_0 + \frac{1}{8}wl^2 = \frac{wEI}{P} \left( \sec \frac{l}{2} \sqrt{\frac{P}{EI}} - 1 \right) \dots (6)$$

or, 
$$-M_0 = \frac{wEI}{P} \left( \sec \frac{\pi}{2} \sqrt{\frac{P}{P_e}} - 1 \right) \dots \dots \dots (7)$$

where  $P_e = \frac{\pi^2 EI}{l^2}$ , Euler's limiting value for the ideal strut (Case II., Art. 100). If  $P = P_e$ ,  $M_0$  and  $y_0$  become infinite. The expansion—

$$\sec \theta - 1 = \frac{\theta^2}{2!} + \frac{5\theta^4}{4!} + \frac{61\theta^6}{6!} + \frac{1385\theta^8}{8!} +, \text{etc.}$$

may be applied to (6), which then reduces to—

$$-M_0 = \frac{wl^2}{8} \left\{ 1 + \frac{5\pi^2}{48} \left(\frac{P}{P_e}\right) + \frac{61\pi^4}{5760} \left(\frac{P}{P_e}\right)^2 + \frac{277\pi^6}{258,048} \left(\frac{P}{P_e}\right)^3 +, \text{etc.} \right\} \dots (8)$$

or—

$$-M_0 = \frac{wl^2}{8} + \frac{5}{384} \frac{wl^4}{EI} \cdot P \left\{ 1 + \frac{61\pi^2}{600} \cdot \frac{P}{P_e} + \frac{277\pi^4}{26,880} \left(\frac{P}{P_e}\right)^2 +, \text{etc.} \right\} \dots (9)$$

These two forms (8) and (9) show the relation of the approximate methods mentioned in the previous article to the more exact method of calculating bending moment. The first term in each is the bending moment due to the lateral loads alone; the second term in (9) is the product of the axial thrust P and the deflection  $\frac{5}{384} \frac{wl^4}{EI}$  (see (11), Art. 78) due to the transverse load alone. Even in the longest struts  $\frac{P}{P_e}$  will not exceed about  $\frac{1}{6}$ , and in shorter ones will be much less. The errors involved in the approximate method of calculation, which gives the first two terms in (9), are evidently then not great.<sup>1</sup>

An approximate solution<sup>2</sup> of equation (1) may be obtained by writing, instead of  $\frac{w}{2} \left( \frac{l^2}{4} - x^2 \right)$ , the very similar expression  $\frac{wl^2}{8} \cos \frac{x}{l} \pi$ ; this makes—

$$y = \frac{wl^2}{8} \cdot \frac{\cos \frac{\pi x}{l}}{P_e - P} \dots \dots \dots (10)$$

$$y_0 = \frac{wl^2}{8(P_e - P)} \dots \dots \dots (11)$$

$$-M_0 = \frac{1}{8}wl^2 \frac{P_e - P}{P_e} \dots \dots \dots (12)$$

<sup>1</sup> See a paper by the Author in the *Phil. Mag.*, June, 1908.

<sup>2</sup> See a paper by Prof. Perry in *Phil. Mag.*, March, 1892. The same result may be obtained by taking all the numerical coefficients in (8) as unity.

Whether the bending moment is calculated by the approximate methods of the previous article applicable to short struts, or by (7) or by (12), the maximum intensity of bending stress  $p_b$  disregarding sign, by Art. 63, is—

$$p_b = \frac{M_0 y_1}{I} = \frac{M_0}{Z} = \frac{M_0 d}{2I} \dots \dots \dots (13)$$

where  $y_1$  is the half-depth  $\frac{d}{2}$  in a symmetrical section, and  $Z$  is the modulus of section. Hence, by Art. 97, (1) the maximum intensity of compressive stress—

$$f_c = \frac{M_0}{Z} + p_0 \text{ or } \frac{M_0 d}{2I} + p_0 \dots \dots \dots (14)$$

where  $p_0$  is the mean intensity of compressive stress on the section, viz.  $\frac{P}{A}$ , where  $A$  is the area of cross-section, and the bending moment is taken as positive.

And the maximum intensity of tensile stress is—

$$f_t = \frac{M_0}{Z} - p_0 \text{ or } \frac{M_0 d}{2I} - p_0 \dots \dots \dots (15)$$

which, if negative, gives the minimum intensity of compressive stress. If the section is not symmetrical, the value of the unequal tensile and compressive bending stress intensities must be found as in Art. 63 (6).

The formula (14) affords an indirect means of calculating the dimensions of cross-section for a strut of given shape, in order that, under given axial and lateral loads, the greatest intensity of stress shall not exceed some specified amount. As the method is indirect, involving trial, the value  $M_0 = \frac{1}{8}wl^2$  may be used to give directly a first approximation to the dimensions, which may then be adjusted by testing the values of  $f_c$  by the more accurate expression (14), where  $M_0$  satisfies (7) or (12).

An interesting case of a strut with a lateral load arises in a locomotive coupling rod. The lateral load is that due to the centrifugal force exerted by the material of the rod, so that  $w$  is proportional to the area of cross-section. The area of cross-section is often I-shaped, and the rod often tapers from the centre to the ends. Exact calculation in such a case becomes very complex, if not impossible, even if the axial loads could be accurately estimated. A good estimate of the bending stress may, however, be found by estimating the bending moment and deflection due to lateral loads alone on the beam of variable section, as in Art. 83, and increasing the central bending moment by the amount due to the axial thrust.

If the strut carried a lateral load  $W$  at the centre instead of the uniformly distributed load, equation (2) becomes—

$$\frac{d^2y}{dx^2} + \frac{P}{EI} \cdot y = -\frac{W}{2EI} \left( \frac{l}{2} - x \right) \dots \dots \dots (16)$$

and

$$y_0 = \frac{W}{2P} \sqrt{\frac{EI}{P}} \tan \frac{l}{2} \sqrt{\frac{P}{EI}} - \frac{W_e}{4P} \dots \dots \dots (17)$$

$$-M_0 = \frac{2}{W} \sqrt{\frac{P}{EI}} \tan \frac{l}{2} \sqrt{\frac{P}{EI}}$$

Other cases may be found in a paper in the *Philosophical Magazine*, June, 1908.

107. Tie-rod with Lateral Loads.<sup>1</sup>—The notation being, as in the previous article, the only change necessary in considering a tie-rod instead of a strut is a reversal in the sign of P. Thus equation (2), Art. 106, becomes—

$$\frac{d^2y}{dx^2} - \frac{P}{EI} \cdot y = -\frac{w}{2EI} \left( \frac{l^2}{4} - x^2 \right) \dots \dots \dots (1)$$

and the conditions of fixing being the same, the solution is—

$$y = -\frac{w}{2P} x^2 + \frac{wl^2}{8P} - \frac{wEI}{P^2} \left( 1 - \operatorname{sech} \sqrt{\frac{P}{EI}} \frac{l}{2} \cosh \sqrt{\frac{P}{EI}} x \right) \dots (2)$$

and—

$$-M_0 = \frac{wEI}{P} \left( 1 - \operatorname{sech} \frac{l}{2} \sqrt{\frac{P}{EI}} \right) = \frac{wEI}{P} \left( 1 - \operatorname{sech} \frac{\pi}{2} \sqrt{\frac{P}{P_e}} \right) \dots (3)$$

If the previous substitution  $\frac{1}{8}wl^2 \cos \frac{x}{l}\pi$  be made for  $\frac{w}{2} \left( \frac{l}{4} - x^2 \right)$  in (1) the solution makes  $-M_0 = \frac{1}{8}wl^2 \frac{P_e}{P_e + P}$ . Which may also be obtained by expanding (3) in a series of terms of rising powers of  $\frac{P}{P_e}$  the coefficients being approximately +1 and -1 alternately.

The stress intensities due to bending and axial pull may be calculated as in the previous article, disregarding the sign of  $M_0$ —

$$f_t = \frac{M_0}{Z} + p_0 \dots \dots \dots (4)$$

$$f_c = \frac{M_0}{Z} - p_0 \text{ (which may be positive or negative) } \dots (5)$$

If the tie-rod carries only a lateral load W at the centre, (16) of Art. 106 becomes—

$$\frac{d^2y}{dx^2} - \frac{P}{EI} \cdot y = -\frac{W}{2EI} \left( \frac{l}{2} - x \right) \dots \dots \dots (6)$$

and

$$y_0 = \frac{W}{2P} \sqrt{\frac{EI}{P}} \tanh \frac{l}{2} \sqrt{\frac{P}{EI}}$$

$$-M_0 = \frac{W}{2} \sqrt{\frac{EI}{P}} \tanh \frac{l}{2} \sqrt{\frac{P}{EI}}$$

<sup>1</sup> See a paper by the Author in the *Phil. Mag.*, June, 1908.

Other cases may be found in a paper in the *Philosophical Magazine*, June, 1908.

EXAMPLE 1.—A round bar of steel one inch diameter and 10 feet long has axial forces applied to the centres of each end, and being freely supported in a horizontal position carries the lateral load of its own weight (0.28 lb. per cubic inch). Find the greatest intensity of compressive and tensile stress in the bar: (a) under an axial thrust of 500 lbs.; (b) under an axial pull of 500 lbs.; (c) with no axial force. ( $E = 30 \times 10^6$  lbs. per square inch.)

$$P_e = \frac{\pi^2 \times 30 \times 10^6 \times \pi}{120 \times 120 \times 64} = 1010 \text{ lbs.} \quad w = 0.28 \times \frac{\pi}{4} = 0.22 \text{ lb.}$$

(a) The maximum intensity of bending stress by (7) and (13), Art. 106, is—

$$p_b = \frac{M_0}{Z} = \frac{wEI}{PZ} \left( \sec \frac{\pi}{2} \sqrt{\frac{P}{P_e}} - 1 \right)$$

and since  $\frac{I}{Z} = \frac{1}{2}$  inch—

$$p_b = \frac{22}{100} \times \frac{30 \times 10^6}{500 \times 2} \{ \sec (90 \times 0.7036)^\circ - 1 \}$$

$$= 6600 \times 1.2274 = 8100 \text{ lbs. per square inch}$$

$$p_o = \frac{P}{A} = \frac{500}{0.7854} = 637 \text{ lbs. per square inch}$$

Maximum compressive stress  $f_c = 8100 + 637 = 8737$  lbs. per square inch.

Maximum tensile stress  $f_t = 8100 - 637 = 7463$  lbs. per square inch.

(b) The maximum intensity of bending stress, by (3), Art. 107, is—

$$\frac{wEI}{PZ} \left( 1 - \operatorname{sech} \frac{\pi}{2} \times 0.7036 \right) = 6600 \times (1 - \operatorname{sech} 1.1042)$$

$$p_b = 6600 \times 0.4040 = 2666 \text{ lbs. per square inch}$$

$$f_t = 2666 + 637 = 3303 \text{ lbs. per square inch}$$

$$f_c = 2666 - 637 = 2029 \text{ lbs. per square inch}$$

$$(c) f_t = f_c = \frac{M_0}{Z} = \frac{1}{8} \times \frac{22}{100} \times \frac{120 \times 120 \times 32}{\pi}$$

$$= 4030 \text{ lbs. per square inch}$$

EXAMPLE 2.—Find how far from the axis the 500-lb. end thrusts in Ex. 1 should be applied in order to produce the least possible intensity of stress.

Let  $h$  be the necessary eccentricity of the thrust below the axis.

Then, as in Art. 106 (1), with the addition of the moment  $P \cdot h$ —

$$EI \frac{d^2y}{dx^2} = -\frac{w}{2} \left( \frac{l^2}{4} - x^2 \right) - P \cdot y + Ph$$

the solution of which is, as in Art. 106, and at the centre—

$$y_0 = -\frac{wl^2}{8P} - \left(\frac{wEI}{P^2} - h\right) \left(1 - \sec \frac{l}{2} \sqrt{\frac{P}{EI}}\right)$$

and—

$$-M_0 = P(y - h) + \frac{wl^2}{8} = \frac{wEI}{P} \left(\sec \frac{l}{2} \sqrt{\frac{P}{EI}} - 1\right) - P \cdot h \sec \frac{l}{2} \sqrt{\frac{P}{EI}}$$

which causes upward concavity if the first term is greater than the second; and at the ends the bending moment producing convexity upwards is—

$$P \cdot h$$

A consideration of the bending-moment diagram or the above expressions will show that as  $h$  increases the magnitude of the bending moment at the ends increases from zero, and the magnitude of the bending moment at the centre decreases, and for the least bending moment, bending stress and value of  $f_c$ , the bending moments at the ends and centre should be equal in magnitude and opposite in sign, or—

$$Ph = \frac{wEI}{P} \left(\sec \frac{l}{2} \sqrt{\frac{P}{EI}} - 1\right) - P \cdot h \sec \frac{l}{2} \sqrt{\frac{P}{EI}}$$

hence

$$h = \frac{wEI}{P^2} \cdot \frac{\sec \frac{l}{2} \sqrt{\frac{P}{EI}} - 1}{\sec \frac{l}{2} \sqrt{\frac{P}{EI}} + 1}$$

and

$$f_c = \frac{P}{A} + \frac{P \cdot h}{Z} = \frac{P}{A} + \frac{wEI}{PZ} \left(\frac{\sec \frac{l}{2} \sqrt{\frac{P}{EI}} - 1}{\sec \frac{l}{2} \sqrt{\frac{P}{EI}} + 1}\right)$$

Using the numerical values from Example 1—

$$h = \frac{22}{100} \times \frac{30 \times 10^6}{250,000} \times \frac{\pi}{64} \times \frac{1 \cdot 2274}{3 \cdot 2274} = 0 \cdot 492 \text{ inch}$$

and the value  $p_0$  being reduced by the eccentricity in the ratio 1 to 3'2274—

$$f_c = 637 + \frac{8100}{3 \cdot 2274} = 637 + 2507 = 3144 \text{ lbs. per square inch}$$

EXAMPLE 3.—A locomotive coupling-rod 100 inches long is of I section, area  $6\frac{3}{4}$  square inches, moment of inertia 10 (inches)<sup>4</sup> about a central horizontal axis, and depth  $4\frac{1}{2}$  inches. The maximum thrust in the rod (estimated from the maximum adhesion of the coupled wheel) is 17 tons and the lateral inertia load at full speed is 24 lbs. per inch length. Neglecting friction at the pins, estimate the maximum compressive stress in the rod. ( $E = 13,000$  tons per square inch.)

$$P_c = \frac{13,000 \times \pi^2 \times 10}{10,000} = 128 \cdot 3 \text{ tons} \quad \frac{P}{P_c} = \frac{17}{128 \cdot 3} = 0 \cdot 1326$$

$$\begin{aligned}
 \text{Central bending moment} &= \frac{wEI}{P} \left( \sec \frac{\pi}{2} \sqrt{\frac{P}{P_e}} - 1 \right) \\
 &= \frac{24 \times 13,000 \times 10}{2240 \times 17} (\sec 32.77^\circ - 1) \\
 &= 82 \times 0.189 = 15.5 \text{ ton-inches} \\
 p_b &= \frac{15.5 \times 9}{10 \times 4} = 3.49 \text{ tons per square inch} \\
 p_0 &= \frac{17}{6.75} = 2.52 \quad \text{''} \quad \text{''} \quad \text{''} \\
 f_c &= 6.01 \quad \text{''} \quad \text{''} \quad \text{''}
 \end{aligned}$$

As a check, the central bending moment by the other method (which for working thrusts is very nearly correct) is—

$$\frac{1}{8} w l^2 \frac{P_e}{P_e - P} = 13.4 \times \frac{1}{0.8674} = 15.45 \text{ ton-inches}$$

#### *List of References on Struts, etc.*

- E. HODGKINSON—*Phil. Trans. Royal Society*, 1840. "Experimental Researches on Cast Iron Pillars," *Phil. Trans. Royal Society*, 1857.
- T. C. CLARK—"Iron Bridges (including experiments made for American Bridge Co.)," *Proc. Inst. Civ. Eng.*, vol. liv.
- J. CHRISTIE—"Experiments on Strength of Wrought Iron Struts," *Trans. Am. Soc. Civ. Eng.*, 1884, vol. xiii. Also extract, *Proc. Inst. Civ. Eng.*, vol. lxxvii. p. 396.
- T. C. FIDLER—"On Practical Strength of Columns," *Proc. Inst. Civ. Eng.*, vol. lxxxvi. Also summary and discussion of experimental results in "Treatise on Bridge Construction" (Griffin).
- AYRTON AND PERRY—"Struts," *Engineer*, December 10 and 24, 1886.
- R. H. SMITH—"Struts," *Engineer*, October 14 and 28, and November 25, 1887. Also see discussion on paper by Lilly, mentioned below.
- J. PERRY—"Struts with Lateral Loads," *Philosophical Magazine*, March, 1892, or *Proc. Physical Society*, vol. xi., December, 1891.
- J. M. MONCRIEFF—"The Practical Column under Central and Eccentric Loads," *Trans. Am. Soc. Civ. Eng.*, vol. xlv. (1900). Also *Engineering*, June 6, 1902.
- W. E. LILLY—"The Strength of Columns," *Proc. Inst. Mech. Eng.*, June, 1905. Also *Engineering*, July 2, 1909, and January 14, 1910.
- A. MORLEY—"Laterally loaded Struts and Ties," *Philosophical Magazine*, June, 1908.

#### EXAMPLES IX.

1. In a short cast-iron column 6 inches external and 5 inches internal diameter the load is 12 tons, and the axis of this thrust passes  $\frac{1}{2}$  inch from the centre of the section. Find the greatest and least intensities of compressive stress.

2. The axis of pull in a tie-bar 4 inches deep and  $1\frac{1}{2}$  inch wide passes  $\frac{1}{10}$  inch from the centre of the section and is in the centre of the depth.

Find the maximum and minimum intensities of tensile stress on the bar at this section, the total pull being 24 tons.

3. The vertical pillar of a crane is of I section, the depth of section parallel to the web being 25 inches, area 24 square inches, and the moment of inertia about a central axis parallel to the flanges being 3000 (inches)<sup>4</sup>. When a load of 10 tons is carried at a radius of 14 feet horizontally from the centroid of the section of the pillar, find the maximum intensities of compressive and tensile stress in the pillar.

4. If a cylindrical masonry column is 3 feet diameter and the horizontal wind pressure is 50 lbs. per foot of height, assuming perfect elasticity, to what height may the column be built without causing tension at the base if the masonry weighs 140 lbs. per cubic foot?

5. A mild-steel strut 5 feet long has a T-shaped cross-section the area of which is 4.771 square inches, the least moment of inertia of which is 6.07 (inches)<sup>4</sup>. Find the ultimate load for this strut, the ends of which are freely hinged, if the crushing strength is taken as 21 tons per square inch and the constant  $\alpha$  of Rankine's formula  $\frac{1}{7500}$ .

6. Find the greatest length for which the section in problem No. 5 may be used, with ends freely hinged, in order to carry a working load of 4 tons per square inch of section, the working load being  $\frac{1}{4}$  of the crippling load and the constants as before.

7. A mild-steel stanchion, the cross-sectional area of which is 53.52 square inches, is as shown in Fig. 149; the least radius of gyration is 4.5 inches. The length being 24 feet and both ends being fixed, find the crippling load by Rankine's formula, using the constants given in Art. 102.

8. Find the ultimate load for the column in problem No. 7, if it is fixed at one end and free at the other.

9. Find the breaking load of a cast-iron column 8 inches external and 6 inches internal diameter, 20 feet long and fixed at each end. Use Rankine's constants.

10. Find the working load for a mild-steel strut 12 feet long composed of two T-sections 6"  $\times$  4"  $\times$   $\frac{1}{2}$ ", the two 6-inch cross-pieces being placed back to back, the strut being fixed at both ends. Take the working load as  $\frac{1}{4}$  the crippling load by Rankine's rule.

11. Find the ultimate load on a steel strut of the same cross-section as that in problem No. 10, if the length is 8 feet and both ends are freely hinged.

12. Find the necessary thickness of metal in a cast-iron pillar 15 feet long and 9 inches external diameter, fixed at both ends, to carry a load of 50 tons, the ultimate load being 6 times greater.

13. Find the external diameter of a cast-iron column 20 feet long, fixed at each end, to have a crippling load of 480 tons, the thickness of metal being 1 inch.

14. Solve problem No. 1 if the column is 10 feet long, one end being fixed and the other having complete lateral freedom. ( $E = 5000$  tons per square inch.)

15. With the ultimate load as found by Rankine's formula in problem No. 5, what eccentricity of load at the ends of the strut (in the direction of the least radius of gyration and towards the cross-piece of the T) will cause the straight homogeneous strut to reach a compressive stress of 21 tons per square inch, assuming perfect elasticity up to this load? The distance from the centroid of the cross-section to the compression edge is 0.968 inch. ( $E = 13,000$  tons per square inch.)

16. With the eccentricity found in problem No. 15 and a load of 16 tons per square inch of section, of what length may the strut be made in order that the greatest intensity of compressive stress shall not exceed 21 tons per

square inch? What is then the least intensity of stress, the distance from the centroid of the cross-section to the tension edge being 3'032 inches?

17. Find the load which will cause an extreme compressive stress of 21 tons per square inch in a stanchion of the section given in problem No. 7, 12 feet long and freely hinged at the ends, if the depth of section in the direction of the least radius of gyration is 16 inches, and the deviation of the load from the centre of the cross-section is 1 inch in the direction of the 16-inch depth. ( $E = 13,000$  tons per square inch.)

18. What load will the column in problem No 1. carry if it is fixed at one end and has complete lateral freedom at the other, if the column is 10 feet long, the eccentricity of loading  $\frac{1}{2}$  inch, and the greatest tensile stress 1 ton per square inch? What is the greatest intensity of compressive stress? ( $E = 5000$  tons per square inch)

19. Find the necessary diameter of a mild-steel strut 5 feet long, freely hinged at each end, if it has to carry a thrust of 12 tons with a possible deviation from the axis of  $\frac{1}{10}$  of the diameter, the greatest compressive stress not to exceed 6 tons per square inch. ( $E = 13,000$  tons per square inch.)

20. Solve problem No. 18 if the deviation may amount to 1 inch.

21. A round straight bar of steel 5 feet long and 1 inch diameter rests in a horizontal position, the ends being freely supported. If an axial thrust of 2000 lbs. is applied to each end, find the extreme intensities of stress in the material. Weight of steel, 0.28 lb. per cubic inch. ( $E = 30 \times 10^6$  lbs. per square inch.)

22. Find what eccentricity of the 2000-lbs. thrust in the previous problem will make the greatest intensity of compressive stress in the bar the least possible, and the magnitude of the stress intensity.

23. A locomotive coupling-rod is of rectangular cross-section,  $3\frac{1}{2}$  inches deep and  $1\frac{1}{4}$  inch wide. The maximum thrust in the rod is estimated at 10 tons and the maximum inertia and gravity load at 17 lbs. per inch length. The length of the rod between centres being 8 feet 4 inches, neglecting friction at the pins, estimate the maximum intensity of stress in the rod.



## CHAPTER X.

### TWISTING.

108. Stress and Strain in Pure Torsion. Circular Section.—When a cylindrical bar is twisted by a couple the axis of which coincides with that of the bar, it is subjected to pure torsion. The stress at any point in a cross-section is one of pure shear, the two planes across

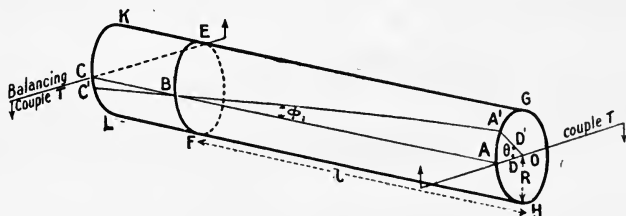

FIG. 152.

which the stress is wholly tangential (see Art. 8) being (1) that containing the point and perpendicular to the axis, and (2) the plane through that point and the axis. The direction of stress on the former plane is everywhere perpendicular to radial lines from the axis. The principal planes are inclined at  $45^\circ$  to those of tangential or shear stress (see Arts. 8 and 15), and the intensities of the two principal stresses, which are of opposite sign, are of the same magnitude as the intensity of shear stress.

The strain is such that any section perpendicular to the axis of the bar makes a small rotation about the axis of the bar relative to other similar sections. The nature of the strain within the elastic limit is illustrated in Fig. 152, which represents a solid cylindrical bar in equilibrium under two equal and opposite couples at its ends. A line ABC on the curved surface, originally straight and parallel to the axis of the bar, after the strain takes place becomes part of a helix A'BC', which everywhere makes an angle  $\phi_1$  with lines such as AB, which are parallel to the axis; the constancy of this angle would be apparent if the curved surface were developed into a plane one, when A'BC' would be a straight line. The angle  $\phi_1$  is the shear strain (Art. 10)

for all the material at the curved surface, and the elastic strain being small—

$$\phi_1 = \frac{AA'}{AB} = \frac{f_s}{N} \text{ (radians) . . . . . (1)}$$

where  $f_s$  is the intensity of shear stress at the surface, and  $N$  is the modulus of rigidity (see Art. 10).

For any point such as  $D$ , distant  $r$  from the centre of the cross-section, the shear strain  $\phi$  and intensity of shear stress  $q$  are similarly connected by the equation—

$$\phi = \frac{DD'}{AB} = \frac{q}{N} \text{ (radians) . . . . . (2)}$$

The radial line originally at  $OA$ , after straining occupies a position  $A'O$ , the angle of twist  $AOA'$  being  $\theta$  in a length  $AB$  or  $l$ . If the radius of the bar is  $R$ , from (1)—

$$\theta = \frac{AA'}{AO} = \frac{l\phi_1}{R} \text{ (radians) . . . . . (3)}$$

and similarly from (2)—

$$\theta = \frac{DD'}{OD} = \frac{l\phi}{r} \text{ (radians) . . . . . (4)}$$

From (1) and (3)—

$$f_s = \phi_1 N = \frac{R\theta}{l} \cdot N \text{ . . . . . (5)}$$

and from (2) and (4)—

$$q = \phi N = \frac{r\theta}{l} N \text{ . . . . . (6)}$$

the intensity of shear stress on the cross-section being at every point proportional to the distance  $r$  from the axis, varying from zero at the axis to the extreme value  $f_s$  at the circumference.

**109. Relation between Twisting Effort, Torsional Strain and Stress.**—The relation between a given torsional straining action and the effects produced within the elastic limit on a cylindrical bar of given dimensions may be calculated from the principles of equilibrium and the formulæ of the previous article.

Considering the equilibrium of the piece  $EGHF$  of the circular bar, Fig. 152, the only external forces upon it are those of the couple  $T$  at the end  $AGH$ , and those exerted by the piece  $KEFL$  in the shear stress across the plane  $EBF$ ; hence the latter must reduce to a couple of magnitude  $T$ , and of opposite sense to that applied at the end  $AGH$ . If Fig. 153 represents the

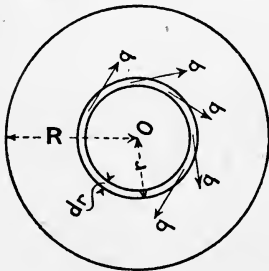

FIG. 153.

cross-section, the total shearing force on an elementary ring of radius  $r$  and width  $\delta r$  is—

$$q \times 2\pi r \delta r$$

and from (5) and (6), Art. 108—

$$q = f_s \cdot \frac{r}{R}$$

hence

$$q \times 2\pi r \delta r = f_s \cdot \frac{2\pi}{R} r^2 \delta r$$

and the moment of this about the axis is—

$$\delta T = 2\pi \frac{f_s}{R} r^3 \delta r$$

Dividing the whole section into elementary concentric rings and summing the moments, the total couple exerted across the section is—

$$T = 2\pi \frac{f_s}{R} \int_0^R r^3 dr = \frac{\pi}{2} f_s R^3 \quad \text{or} \quad \frac{\pi}{16} \cdot f_s \cdot D^3 \quad \dots (1)$$

where  $D$  or  $2R$  is the diameter of the bar. The quantity—

$$2\pi \int_0^R r^3 dr = \frac{\pi R^4}{2} \quad \text{or} \quad \frac{\pi D^4}{32} = J \text{ (say)}$$

is the polar moment of inertia of the area of cross-section about the axis, and (1) may be written—

$$T = f_s \frac{J}{R} = q \cdot \frac{J}{r} \quad \text{or} \quad f_s = \frac{TR}{J} \quad \text{and} \quad q = \frac{Tr}{J} \quad \dots (2)$$

It should be remembered that if, say, inch units of length are used for the dimensions and for  $f_s$ , the same units must be used for  $T$  (pound-inches or ton-inches).

In this form (2) the close analogy between the relations connecting the couple, stress, and dimensions for torsion and those for bending (Art. 63) is apparent, and the quantity  $\frac{J}{R}$  may be called the polar modulus of a solid circular section.

From (5), Art. 108—

$$\theta = \frac{f_s \cdot l}{R \cdot N} = \frac{T \cdot l}{N \cdot J} \quad \text{or} \quad \frac{32Tl}{\pi D^4 N} \text{ (radians)} \quad \dots (3)$$

or  $\frac{T}{NJ}$  radians per unit length; also in degrees—

$$\theta = \frac{583Tl}{ND^4} \text{ degrees} \quad \dots (4)$$

the amount of twist being proportional to the length, and inversely proportional to the (polar) moment of inertia ( $J$ ) of cross-section about the axis, *i.e.* in a shaft of solid circular section, inversely proportional to the fourth power of the diameter. The product  $NJ$  to which the amount of twist is inversely proportional, may be called the torsional rigidity of the shaft. For other than circular sections quantities

somewhat less than  $J$  must be used (see Art. 112). For solid circular sections the intensity of stress from (1) is inversely proportional to the cube of the diameter.

**110. Shaft Diameters for Power Transmission.**—In the transmission of power through a shaft the product of the mean twisting moment or torque multiplied by the angle turned through in (radians) gives the work transmitted. Hence, if  $T$  is the mean twisting moment in pound-inches, caused in transmitting of a horse-power (H.P.) at  $n$  revolutions per minute—

$$T = \frac{12 \times 33,000 \times \text{H.P.}}{2\pi n} \dots \dots \dots (1)$$

The maximum twisting moment will generally be considerably in excess of this amount, as the twisting moment usually varies considerably in driving of all kinds. If some coefficient to represent the ratio of the maximum to the mean torque be adopted, the twisting moment will be—

$$T = \frac{\text{H.P.}}{n} \times \text{constant} \dots \dots \dots (2)$$

and for a shaft transmitting *torsion only* (without bending stress), if  $f_s$  be the intensity of safe maximum shear stress, from (1), Art. 109—

$$D = \sqrt[3]{\frac{16T}{\pi f_s}} = \sqrt[3]{\frac{\text{H.P.}}{n}} \times \text{constant} \dots \dots \dots (3)$$

a common value of the constant for steel shafts being about 3.3. When the maximum twisting moment has been estimated, common working values of  $f_s$  are 8000 to 10,000 lbs. per square inch. Suitable values of  $f_s$  or of the constant in (3) will be found in manuals of machine design.<sup>1</sup> In long shafts the condition that the twist in a given length shall be within some assigned limit may require a larger diameter than considerations of maximum intensity of shear stress. The necessity of this torsional stiffness will be understood from Art. 167.

**111. Hollow Circular Shafts.**—The intensity of stress in a circular shaft being for all points in a cross-section proportional to the distance from the axis, when the material at the outside of a solid shaft reaches the maximum safe limit of stress, that about the centre is only carrying a much smaller stress. In the case of a hollow shaft the stress intensity is, as before, everywhere proportional to the distance from the axis, but it varies from a maximum to some smaller value, but not to zero. With the same magnitude of maximum stress the average intensity of stress is greater, and consequently for a given cross-sectional area a greater torque can be resisted.

Let  $R_1$  or  $\frac{D_1}{2}$  and  $R_2$  or  $\frac{D_2}{2}$  be the external and internal radii respectively of a hollow shaft; then Art. 109 (1), integrated between limits, gives—

<sup>1</sup> See Unwin's "Elements of Machine Design," or Low and Bevis's "A Manual of Machine Design" (Longmans).

$$T = 2\pi \frac{f}{R_1} \int_{R_2}^{R_1} r^3 dr = \pi f_s \frac{R_1^4 - R_2^4}{R_1} = \frac{\pi}{16} f_s \cdot \frac{D_1^4 - D_2^4}{D_1} \quad (1)$$

the value of J in (2) and (3), Art. 109, being—

$$J = \frac{\pi(R_1^4 - R_2^4)}{2}$$

for a hollow shaft. The angle of twist—

$$\theta = \frac{32Tl}{\pi(D_1^4 - D_2^4)N} \text{ (radians)} = \frac{583Tl}{N(D_1^4 - D_2^4)} \text{ degrees} \quad (2)$$

Comparing the strength (or twisting resistance for a given extreme intensity of stress) per unit area of cross-section or per unit weight of a hollow shaft with that of a solid shaft, both having the same external diameter—

$$\frac{\text{hollow}}{\text{solid}} = \frac{R_1^4 - R_2^4}{R_1(R_1^2 - R_2^2)} \div \frac{R_1^3}{R_1^2} = 1 + \left(\frac{R_2}{R_1}\right)^2$$

which tends to the limiting ratio 2 as  $R_2$  approaches  $R_1$ , *i.e.* in a thin tube. The ratio of the torsion rigidities of the two shafts is the same as that of their strengths.

**112. Torsion of Shafts not Circular in Section.**—The torsion of shafts symmetrical but not circular in section is very complex. The cross-sections originally plane become warped, and the greatest intensity of shearing stress generally occurs at the point of the perimeter of cross-section *nearest* to the axis of twist or centroid of cross-section. The subject has been investigated by St. Venant, who has devised simple empirical formulæ for cases where the more exact results are complex. An account of St. Venant's work will be found in Todhunter and Pearson's "History of the Theory of Elasticity," vol. ii. part 1, from which the following values have been derived. The notation is that of the four preceding articles.

*Square Section.*—Length of side  $s$ . The greatest intensity of stress  $f$  occurs at the middle of the sides—

$$T = 0.208 \cdot s^3 \cdot f_s \quad (1)$$

which is only about 6 per cent. greater than  $\frac{\pi}{16} \cdot f_s \cdot s^3$ , the value for the inscribed circle. Also—

$$\theta = 7.11 \frac{T \cdot l}{N \cdot s^4} = \frac{Tl}{0.844N \cdot J} \quad (2)$$

J being  $\frac{s^4}{6}$ .

*Elliptic Section.*—Major axis  $a$ , minor axis  $b$ . The greatest intensity of stress  $f_s$  occurs at the ends of the minor axis.

$$T = \frac{\pi}{16} ab^2 f_s \quad (3)$$

$$\theta = \frac{16}{\pi} \frac{(a^2 + b^2)}{a^3 b^3} \cdot \frac{Tl}{N} \quad (4)$$

*Rectangular Section.*—Long side  $a$ , short side  $b$ . Maximum intensity of stress  $f_s$  occurs at the middle points of the long sides—

$$T = \frac{a^2 b^3}{3a + 1.8b} \cdot f_s \quad \text{or} \quad \frac{ab^3}{3 + 1.8\frac{b}{a}} \cdot f_s \quad \dots (5)$$

For more exact values of the empirical coefficient—

$$\frac{1}{3 + 1.8\frac{b}{a}}$$

see a table in Todhunter and Pearson's "History of Elasticity," vol. ii. pt. 1, p. 39.

For any symmetrical section including rectangles approximately—

$$\theta = \frac{40J}{A^2} \cdot \frac{TL}{N} \quad \dots (6)$$

where  $A$  is the area of cross-section and  $J$  is the polar moment of inertia. Instead of 40, for a circular or elliptic section the exact factor is  $4\pi^2$ , and for rectangles, where  $\frac{a}{b}$  is less than 3, the factor is about 42.

*Round Shafts with Keyways.*—For a given elastic stress limit  $f_s$ , the torque applied to a circular shaft having a keyway of width  $w$  times the shaft diameter, and depth  $h$  times the shaft diameter, expressed as a fraction of the torque applied to the uncut shaft may be taken as<sup>1</sup>—

$$1.0 - 0.2w - 1.1h$$

The elastic deflection is increased in the ratio

$$1.0 + 0.4w + 0.7h$$

**EXAMPLE 1.**—Find the maximum intensity of torsional shear stress in a shaft 3 inches diameter transmitting 50 H.P. at 80 revolutions per minute if the maximum twisting moment exceeds the mean by 40 per cent. What is the greatest twist in degrees per foot of length if  $N = 12 \times 10^6$  lbs. per square inch?

The twisting moment in lb.-inches is—

$$T = \frac{33,000 \times 12 \times 50 \times 1.4}{80 \times 2\pi} = 55,125 \text{ lb.-inches}$$

$$f_s = \frac{16}{\pi} \times \frac{T}{d^3} = \frac{16 \times 55,125}{27\pi} = 10,400 \text{ lbs. per square inch}$$

The twist per foot length in degrees is—

$$\theta^\circ = \frac{55,125 \times 12}{\frac{\pi}{32} \times 81 \times 12 \times 10^6} \times \frac{180}{\pi} = 0.398^\circ$$

**EXAMPLE 2.**—A solid round shaft is replaced by a hollow one, the external diameter of which is  $1\frac{1}{4}$  times the internal diameter. Allowing the same intensity of torsional stress in each, compare the weight and the stiffness of the solid with those of the hollow shaft.

<sup>1</sup> This experimental result, due to Prof. H. F. Moore, is taken from Bulletin No. 42 of the Engineering Experimental Station, University of Illinois.

Let  $d$  be the diameter of the solid shaft, and  $D$  be that of the hollow one.

For equal strength—

$$d^3 = \frac{D^4 - (0.8D)^4}{D} = (1 - 0.4096)D^3$$

$$\frac{D}{d} = \sqrt[3]{\frac{1}{0.5904}} = \sqrt[3]{1.696} = 1.192$$

Ratio of weight—

$$\frac{\text{solid}}{\text{hollow}} = \frac{1}{(1.192)^2(1 - 0.8^2)} = 1.96$$

Ratio of stiffness—

$$\frac{\text{hollow}}{\text{solid}} = \frac{(1.192)^4(1 - 0.8^4)}{1} = 1.19$$

**113. Combined Bending and Torsion.**—In the preceding articles it has been assumed that the shafts have been subjected to an axial couple producing torsional shear stress only; in practice nearly all shafts are subject also to bending actions due to their own weight or that of pulleys, or to the thrust or pull of cranks and belts. The component stresses in the shaft will therefore be (1) shear stress due to torsion, on planes perpendicular to and planes through the axis; (2) tensile and compressive bending stresses parallel to the axis; (3) shear stresses resulting from bending forces, on planes parallel to and perpendicular to the axis. In shafts which are not very short, the maximum principal stresses will generally occur at the circumference of the shaft, where the tensile and compressive stresses on opposite sides reach equal and opposite maximum values; in this case, the shear stress resulting from the bending forces need not be taken into account, being zero at the circumference (see Art. 71). In very short shafts it may happen that the component shear stress caused by the bending forces is more important than the direct stress parallel to the axis: in this case, the greatest principal stress may be within the section; usually, however, the maximum principal stress is at the circumference. Let  $f$  be the value of the extreme equal and opposite intensities of longitudinal bending stress occurring at opposite ends of a diameter of a section, viz.—

$$f = \frac{M}{Z} = \frac{32M}{\pi d^3} \quad (\text{Arts. 63 and 66}) \quad (1)$$

where  $Z = \frac{\pi}{32}d^3$  is the modulus of section for a round shaft of diameter  $d$  subjected to a bending moment  $M$ . Let  $f_s$  be the extreme value of  $q$ , the intensity of torsional shear stress occurring at the circumference, so that—

$$f_s = \frac{16T}{\pi d^3} \quad (\text{Art. 109 (1)}) \quad (2)$$

The intensities of the principal stresses may be found as in Art. 18, the maximum value being—

$$f_1 = \frac{1}{2}f + \sqrt{\frac{1}{4}f^2 + f_s^2} \dots \dots \dots (3)$$

this being tensile on the skin which has maximum tensile bending stress, and compressive diametrically opposite. Substituting the above values for  $f$  and  $f_s$ —

$$f_1 = \frac{16}{\pi d^3} (M + \sqrt{M^2 + T^2}) \dots \dots \dots (4)$$

or 
$$f_1 = \frac{32}{\pi d^3} \left\{ \frac{1}{2}(M + \sqrt{M^2 + T^2}) \right\} \dots \dots \dots (5)$$

From (5) it is evident that the bending moment—

$$M_e = \frac{1}{2}(M + \sqrt{M^2 + T^2}) \dots \dots \dots (6)$$

without torsion would produce a direct bending stress equal to the maximum principal stress  $f_1$ ; it is therefore sometimes called the equivalent bending moment.

Similarly, from the relation (4) the quantity—

$$T_e = M + \sqrt{M^2 + T^2} \dots \dots \dots (7)$$

is called the equivalent twisting moment, since a twisting moment of this value without any bending action would produce a torsional shear stress of intensity  $f_1$ , and consequently a principal stress of the same magnitude (see Art. 8).

For a hollow shaft of external diameter  $D_1$  and internal diameter  $D_2$ —

$$f_1 = \frac{16D_1}{\pi(D_1^4 - D_2^4)} (M + \sqrt{M^2 + T^2}) \dots \dots \dots (8)$$

the values of  $M_e$  and  $T_e$  from (6) and (7) being as before.

Combined bending and torsion being perhaps the most important case of compound stress, it is instructive to notice that if the principal direct strain is the criterion for elastic failure, and Poisson's ratio is  $\frac{1}{4}$ , (2) of Art. 25 makes the equivalent bending moment—

$$\frac{8}{5}M + \frac{5}{8}\sqrt{M^2 + T^2} \dots \dots \dots (9)$$

which is greater than  $M_e$  in (6). When the value in (6) is used, a rather lower working value of the intensity of stress would be used than with the value (9) (see Art. 25). If the criterion is the maximum shear stress, which is—

$$\sqrt{\frac{1}{4}f^2 + f_s^2} \text{ or } \frac{16}{\pi d^3} \sqrt{M^2 + T^2}$$

the bending moment which, acting alone, would produce this intensity of *shear stress* (on planes inclined  $45^\circ$  to the axis of the shaft) is—

$$\sqrt{M^2 + T^2} \dots \dots \dots (10)$$



which is greater than (6) or (9). A twisting moment  $\sqrt{M^2 + T^2}$  would also produce the same intensity of shear stress. If  $\theta$  is the angle which the axis of principal stress makes with the axis of the shaft, or which the principal plane makes with the cross-section, by (3), Art. 17—

$$\tan 2\theta = \frac{2f_s}{f} = \frac{T}{M}$$

**114. Effect of End Thrust.**—If there is an axial thrust or pull in addition to bending and twisting forces, the intensity of stress due to the axial force must be added algebraically to the intensities of longitudinal direct bending stress before the principal stresses are found. For an axial thrust  $P$  the extreme intensity of longitudinal compressive stress will be—

$$f_c = \frac{M}{Z} + \frac{P}{A}$$

where  $A$  is the area of cross-section, and  $M$  the bending moment upon it;  $f_c$  may be used instead of  $f$  in equation (3) of the previous article to find the greatest intensity of compressive stress.

The extreme intensity of longitudinal tensile stress will be—

$$f_t = \frac{M}{Z} - \frac{P}{A}$$

which (if positive), when used instead of  $f$  in equation (3) of the previous article, will give the greatest intensity of tensile principal stress.

**EXAMPLE 1.**—A shaft 3 inches diameter is subjected to a twisting moment of 40,000 lb.-inches, and a bending moment of 10,000 lb.-inches. Find the maximum principal stress. If Poisson's ratio is  $\frac{1}{4}$ , find the direct stress which, acting alone, would produce the same maximum strain.

Intensity of torsional shear stress—

$$f_s = \frac{16 \times 40,000}{\pi \times 27} = 7544 \text{ lbs. per square inch}$$

Intensity of bending stress—

$$f = \frac{32 \times 10,000}{\pi \times 27} = 3772 \text{ lbs. per square inch}$$

Intensity of maximum principal stress—

$$\frac{1}{2}f + \sqrt{\frac{1}{4}f^2 + f_s^2} = 1886 + 100\sqrt{356 + 5694} = 9664 \text{ lbs. per square inch}$$

Intensity of minimum principal stress—

$$1886 - 100\sqrt{356 + 5694} = -5892 \text{ lbs. per square inch}$$

Maximum strain in the direction of the maximum principal stress (see Art. 19) is—

$$\frac{1}{E} \left( 9664 + \frac{5892}{4} \right) = \frac{11,137}{E}$$

Direct stress to produce this strain would be 11,137 lbs. per square inch.

EXAMPLE 2.—A propeller shaft is subjected to a twisting moment of 180 ton-feet, a bending moment of 40 ton-feet, and a direct thrust of 30 tons. If its external diameter is 16 inches, and its internal diameter 8 inches, find the maximum intensity of compressive stress.

The *polar* modulus of section is—

$$\frac{\pi}{16} \cdot \frac{16^4 - 8^4}{16} = 240\pi = 755 \text{ (inches)}^3$$

and the “bending” modulus is half this amount.

The maximum torsional shear stress in a cross-section is—

$$f_s = \frac{180 \times 12}{755} = 2.86 \text{ tons per square inch}$$

The maximum bending stress is—

$$\frac{40 \times 12 \times 2}{755} = 1.27 \text{ ton per square inch}$$

and the compression due to thrust is—

$$\frac{30}{0.7854 \times 192} = 0.20 \text{ ton per square inch}$$

The direct compression parallel to the axis is therefore—

$$1.27 + 0.20 = 1.47 \text{ ton per square inch}$$

hence the maximum compressive (principal) stress is—

$$0.735 + \sqrt{0.735^2 + 2.86^2} = 3.688 \text{ tons per square inch}$$

**115. Torsion beyond the Elastic Limit.**—When twisted by a gradually increasing couple until fracture takes place, metals, whether ductile or brittle, exhibit characteristics very similar to those which they show in a tension test. If the twisting moments are plotted as ordinates on a base of angular deformations measured on any fixed length, the resulting diagram is very similar to that for tension and elongation (see Fig. 31). In the case of ductile metals, the yield point and limit of proportionality of angular strain to twisting moment, particularly in a solid bar, are less marked than in a tension test, being masked by the fact that the whole of the material does not reach those points simultaneously, the outer layers first reaching them, and the more plastic condition spreading towards the axis as straining proceeds.

The yield point would be more clearly observed in a thin hollow tube. There being no appreciable reduction in section, there is no "droop" in the curve such as occurs when local contraction takes place in a tension test, but the curve becoming almost parallel to the strain axis or base, indicates that the material has become practically perfectly plastic. In such a case the intensity of shear stress, instead of being proportional to the distance from the axis of the bar, is practically uniform over the section, and instead of (1), Art. 109, the twisting moment  $T$  is related to the ultimate intensity of shear stress  $f_s$ , and the radius  $R$  or  $\frac{d}{2}$ , as follows:—

$$T = 2\pi f_s \int_0^R r^2 dr = \frac{2}{3}\pi f_s R^3 \quad \text{or} \quad \frac{\pi}{12} \cdot f_s \cdot d^3$$

*Fractures.*—In ductile materials the fracture is generally almost plane and perpendicular to the axis of twist. In brittle materials, such as cast iron, in which under torsion fracture apparently occurs by tension, the surface of fracture meets the cylindrical surface in a regular helix inclined  $45^\circ$  to the axis of the specimen, this being perpendicular to the direction of the tensile principal stress (see Arts. 8 and 108, and Fig. 219).

*Other Phenomena.*—The raising of the yield point by stress, recovery of elasticity with time, and similar effects, may be observed in materials torsionally strained beyond the primitive yield point much in the same manner as in tension experiments. An account of sundry experiments<sup>1</sup> of this kind by Dr. E. G. Coker is to be found in the *Phil. Trans. Roy. Soc. of Edinburgh*, vol. xl. part ii. No. 14.

**116. Torsional Resilience.**—The elastic strain energy or shearing resilience of a material having a uniform intensity of shear stress  $q$  is—

$$\frac{1}{2} \frac{q^2}{N}$$

per unit of volume (Art. 95). If we consider a solid shaft torsionally strained within the elastic limit, the shearing resilience of any tubular element of radius  $r$ , thickness  $dr$ , and length  $l$ , is—

$$\frac{1}{2} \frac{q^2}{N} \cdot 2\pi l r \cdot dr$$

where

$$q = \frac{r}{R} \cdot f_s$$

$f_s$  being the intensity of shear stress at the outer radius  $R$ . Hence the total torsional resilience of the shaft is—

$$\frac{\pi l}{N} \int_0^R q^2 r dr = \frac{\pi l}{N} \cdot \frac{f_s^2}{R^2} \int_0^R r^3 dr = \frac{1}{4} \frac{\pi R^2 l f_s^2}{N} = \frac{1}{4} \frac{f_s^2}{N} \times \text{volume} \quad (1)$$

<sup>1</sup> See also "Tests of Metal in Reverse Torsion," by Prof. E. L. Hancock, *Phil. Mag.*, 1906, vol. xii. p. 426.

In the case of a hollow cylindrical shaft of outer and inner radius  $R_1$  and  $R_2$  respectively the torsional resilience is similarly—

$$\frac{\pi l f_s^2}{N R_1^2} \int_{R_2}^{R_1} r^3 dr = \frac{\pi l f_s^2}{4N R_1^2} (R_1^4 - R_2^4) = \frac{R_1^2 + R_2^2}{R_1^2} \times \frac{1}{4} \frac{f_s^2}{N} \times \text{volume} \quad (2)$$

which approaches  $\frac{1}{2} \frac{f_s^2}{N}$  per unit of volume as  $R_2$  approaches  $R_1$ , *i.e.* for a thin tube where the intensity of shear stress is nearly uniform.

If  $f_s$  in (1) and (2) represents the intensity of shear stress at the elastic limit, the above expressions may be called the proof torsional resilience in conformity with the terminology adopted in Art. 42.

An alternative method of arriving at the above results would be to take the work done in twisting, *viz.* half the product of the twisting moment and the angle of twist or—

$$\frac{1}{2} \cdot T \cdot \theta$$

and substitute for  $T$  and  $\theta$  from (1) and (3), Art. 109, in the case of a solid cylindrical shaft, and corresponding values for the hollow shaft (Art. 111).

This method might well be applied to other sections in which the distribution of stress is not so simple, *e.g.* for a square shaft; the resilience, using the formulæ (1) and (2) of Art. 112, is—

$$\begin{aligned} \frac{1}{2} T \theta &= \frac{1}{2} \times 7 \cdot 11 \times \frac{T^2 l}{N S^3} = \frac{7 \cdot 11}{2} \cdot \frac{(0 \cdot 208)^2 s^2 f_s^2 l}{N} = 0 \cdot 154 \frac{f_s^2}{N} \cdot s^2 l \\ &= 0 \cdot 154 \frac{f_s^2}{N} \times \text{volume} \dots \dots \dots (3) \end{aligned}$$

The same method might be extended to the other sections given in Art. 112.

### 117. Helical Springs, close coiled.

(a) *Axial Load.*—The material of a helical spring wound so closely that any one coil lies nearly in a plane perpendicular to the axis of the helix may be regarded as subject to torsion only, when the spring is acted on by an axial pull or thrust; the twisting moment exerted on the wire of the helix is the product of the axial force and the radius of the cylindrical surface containing the helix or centre line of the wire, *i.e.* the mean radius of the coils. When the helix is not “close coiled” the axial force causes bending of the coils in addition to torsion of the wire, and in any case there is on every cross-section of the wire the shearing force due to the axial load apart from the torsional shear. In many cases, however, the torsional strain is so much greater than that due to bending or shear, that strains other than torsional ones may be neglected.

Taking a close-coiled helix of round wire of diameter  $d$ , let  $W$  be the axial load in pounds, say tensile, and  $R$  be the mean radius of the coils in inches (see Fig. 154). Let  $n$  be the number of complete coils

and  $l$  the total length of wire in them, so that the coils being close—

$$l = 2\pi Rn \text{ (approximately)}$$

and let  $N$  be the modulus of rigidity or shearing modulus in pounds per square inch. The whole of the wire is subjected to a twisting moment—

$$T = WR$$

and if one end is held fast the other will, consequently, twist through an angle  $\theta$  (Art. 109 (3))—

$$\theta = \frac{Tl}{NJ} \text{ or } \frac{32Tl}{\pi d^4 N} = \frac{32WRl}{\pi d^4 N} \text{ radians (1)}$$

or  $\frac{T}{NJ}$  radians per unit length. Consequently,

the free end will have an axial movement  $R \cdot \theta$ , as may easily be realized by considering the axial movement of the free end, due to the difference in twist at the ends of any short portion of the total length, and remembering that, one end being fixed, the whole axial movement must take place at the free end. If  $\delta$  is the axial movement or deflection of the free end—

$$\delta = R \cdot \theta = \frac{32WR^2l}{\pi d^4 N} \text{ or } \frac{64WR^3n}{d^4 N} \text{ inches. . . (2)}$$

This might also be obtained very simply by equating the torsional resilience or work done by the twisting moment to the work done in terms of the axial force and deflection, viz.—

$$\frac{1}{2}W \cdot \delta = \frac{1}{2}T\theta = \frac{1}{2}(WR) \frac{32WRl}{\pi d^4 N} \text{ . . . . . (3)}$$

and 
$$\delta = \frac{32WR^2l}{\pi d^4 N} \text{ or } \frac{64WR^3n}{d^4 N} \text{ (as before)}$$

The resilience in inch-pounds is—

$$\frac{16W^2R^2l}{\pi d^4 N} \text{ or } \frac{f_s^2}{4} \times \text{volume}$$

as in Art. 116, where  $f_s = \frac{16}{\pi d^3}WR$ , as in Art. 109 (1).

The deflections for a spring of hollow circular section, *i.e.* made of tubing may similarly be obtained from (1) and (2), Art. 111.

The *stiffness* of a spring in pounds may be defined as the force per unit deflection, and is equal to  $\frac{1}{\delta}$  when  $W$  is one pound. If in the

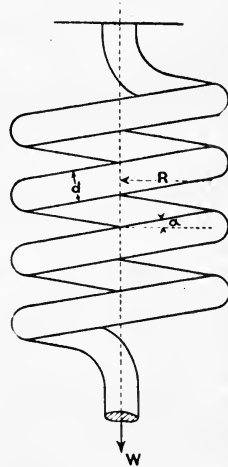

FIG. 154.

above formulæ the linear units are inches (as is usual), the force per foot of deflection may be taken as  $e$  where—

$$e = \frac{12\pi d^4 N}{32R^2 l} = \frac{3\pi d^4 N}{8R^2 l}$$

in the units commonly employed in considering the kinetics of vibrations.

In the case of a square section—

$$\delta = R\theta = 7.11 \frac{WR^2 l}{NS^4}$$

the resilience being  $0.154 \frac{f_s^2}{N}$  per unit volume, as in the previous article.

It is interesting to note that in any of the above cases the resilience per unit volume for a given intensity of shearing stress is much greater than the resilience for uniform tension or for a bent beam (Art. 93) with the same numerical intensity of direct stress,  $N$  for steel being only about  $\frac{2}{5}E$ , and the numerical coefficient being greater for torsion than for bending, because the material is for most usual cases more uniformly stressed. The steel from which springs are usually made has a high elastic limit and correspondingly high capacity for storing strain energy. The safe working value of shear stress for small wires is over 30 tons per square inch when suitably tempered for springs.

(b) *Axial Twist*.—When a closely coiled spring is held at one end and subjected to a twisting couple  $M$  about the axis of the helix, the free end to which the couple is applied is twisted by an amount proportional to the magnitude of the couple. Neglecting any slight obliquity of the coils, whether one coil or several be considered, the wire of which the helix is made has to resist at every normal cross-section a *bending* moment  $M$  tending to bend or unbend the coils of the helix, *i.e.* to increase or decrease their curvature according to the sense of the applied couple. If we assume, as an approximation, that the coils which have considerable initial curvature behave like a beam of initial curvature zero, and that the same relations hold good as in Arts. 61 and 63—

$$\text{bending moment } M = EI \times (\text{change of curvature}) \quad (4)$$

where  $I$  is the moment of inertia of cross-section about the neutral axis of the section, which is through its centroid and parallel to the axis of the helix. This is very nearly correct when the radius of the coil is several times as great as the cross-sectional dimensions of the wire (see Art. 129). If the bending moment increases the curvature, the mean radius of the coils decreasing from  $R$  to  $R'$  and their number increasing from  $n$  to  $n'$ , and  $2\pi nR = 2\pi n'R' = l$ —

$$M = EI \left( \frac{1}{R'} - \frac{1}{R} \right) = \frac{2\pi EI(n' - n)}{l} \dots (5)$$

and the total twist  $\phi$  of the free end in radians is—

$$\phi = 2\pi(n' - n) = \frac{Ml}{EI} \text{ (radians)} \dots (6)$$

This result might easily be obtained from the resilience, for by (7),  
Art. 93—

$$\frac{1}{2}M\phi = \frac{1}{2} \frac{M^2 l}{EI} \dots \dots \dots (7)$$

hence 
$$\phi = \frac{Ml}{EI}$$

The change in curvature or angle of bend per unit length—

$$\frac{1}{R'} - \frac{1}{R} \text{ or } \frac{d\phi}{dl}$$

is uniform throughout the length, and from (5) or (6) its amount is  $\frac{M}{EI}$ .

For a wire of solid circular section and diameter  $d$  (6) becomes—

$$\phi = \frac{64Ml}{\pi E d^4} \text{ or } \frac{128MRn}{E d^4} \text{ radians } \dots \dots (8)$$

and the extreme values of the intensity of direct bending stresses are—

$$f = \frac{32M}{\pi d^3} \dots \dots \dots (9)$$

For a square section of side  $S$  (6) becomes—

$$\phi = \frac{12Ml}{ES^4} \text{ or } \frac{24\pi MRn}{ES^4} \dots \dots \dots (10)$$

and 
$$f = \frac{6M}{S^3} \dots \dots \dots (11)$$

*Resilience.*—For a circular section the resilience is—

$$\frac{1}{8} \cdot \frac{f^2}{E} \text{ per unit volume}$$

and for a rectangular section it is—

$$\frac{1}{6} \cdot \frac{f^2}{E} \text{ per unit volume (see Art. 93)}$$

**118. Open Coiled Helical Spring.**

(1) *Axial Load W.*—With the notation of the previous article, let the coils make everywhere an angle  $\alpha$  with planes perpendicular to the axis of the helix (see Fig. 155, the plane of which is tangential to the cylindrical surface containing the helical centre line of the wire); the length  $l$  of  $n$  coils is then—

$$2\pi Rn \sec \alpha$$

Then the moment  $WR$  about  $OX$ , which the axial force  $W$  exerts on the normal cross-section at  $O$  may be resolved into two moments—

and 
$$\begin{aligned} T' &= WR \cos \alpha \\ M' &= WR \sin \alpha \end{aligned}$$

the former giving a twisting moment about OX' tangent to the centre line of the wire, and the latter a bending moment about an axis OY' perpendicular to the axis of the wire and in the plane of Fig. 155.

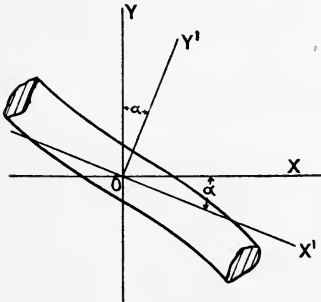

FIG. 155.

If the axial extension only is required we may most easily find it from the strain energy, using (3) and (7) of the previous article. For a circular wire of diameter  $d$ —

$$\begin{aligned} \frac{1}{2}W \cdot \delta &= \frac{1}{2}T'\theta' + \frac{1}{2}M'\phi' \\ &= \frac{1}{2} \frac{T'^2 \cdot l}{NJ} + \frac{1}{2} \frac{M'^2 l}{EI} \dots (1) \end{aligned}$$

where  $\theta'$  and  $\phi'$  are the angular displacements of the free end about such axes as OX' and OY' respectively, or—

$$W\delta = \frac{lW^2R^2 \cos^2 \alpha}{NJ} + \frac{lW^2R^2 \sin^2 \alpha}{EI}$$

and—

$$\delta = WlR^2 \left( \frac{\cos^2 \alpha}{NJ} + \frac{\sin^2 \alpha}{EI} \right) \text{ or } 2W\pi R^3 n \sec \alpha \left( \frac{\cos^2 \alpha}{NJ} + \frac{\sin^2 \alpha}{EI} \right) \quad (2)$$

or—

$$\delta = \frac{32WlR^2}{\pi d^4} \left( \frac{\cos^2 \alpha}{N} + \frac{2 \sin^2 \alpha}{E} \right) = \frac{64WR^3 n \sec \alpha}{d^4} \left( \frac{\cos^2 \alpha}{N} + \frac{2 \sin^2 \alpha}{E} \right) \quad (3)$$

which reduces to the form (2), Art. 117, when  $\alpha = 0$ . Taking  $\frac{N}{E} = \frac{2}{5}$ , the effect of the obliquity on the deflection if  $\alpha = 10^\circ$  is under 1 per cent. and for  $\alpha = 45^\circ$  is about 10 per cent. reduction compared to the case of a close-wound spiral ( $\alpha = 0$ ) having the same length of wire  $l$  for a wire of solid circular section; for some other sections the effect is much greater; for non-circular sections the values of  $\theta$  given in Art. 112 must be used instead of  $\frac{T'l}{NJ}$  in (1).

Both the bending action about the axis OY' and the twisting about OX' cause rotation of the free end of the coil about the axis of the coil; if this rotation  $\phi$  is required it may be deduced by resolving the rotations about OX' and OY' of a short length  $dl$  at O into components about OX and OY. Taking an increased number of coils, *i.e.* increased curvature as a positive value of  $\phi$ , due to twisting moment about OX' the rotation is—

$$d\theta' = \frac{WR \cos \alpha}{NJ} \times dl \dots (4)$$

and the component of this about OY is positive and equal to—

$$\frac{W \cdot R \cdot dl \cdot \cos \alpha}{NJ} \times \sin \alpha \dots (5)$$



The bending about OY' is negative (or "unbending") and is—

$$d\phi' = -\frac{WR \sin \alpha}{EI} \cdot dl \quad \dots \quad (6)$$

and the component of this about OY is—

$$-\frac{W \cdot R \cdot dl \cdot \sin \alpha}{EI} \times \cos \alpha \quad \dots \quad (7)$$

hence the total component rotation about OY is—

$$d\phi = W \cdot R \cdot dl \cdot \sin \alpha \cos \alpha \left( \frac{1}{NJ} - \frac{1}{EI} \right) \quad \dots \quad (8)$$

and for all equal lengths  $dl$  the rotation  $d\phi$  is the same, or  $\frac{d\phi}{dl} = \text{constant}$ , and—

$$\phi = W \cdot R \cdot l \sin \alpha \cos \alpha \left( \frac{1}{NJ} - \frac{1}{EI} \right) \text{ or } 2\pi WR^2 n \sin \alpha \left( \frac{1}{NJ} - \frac{1}{EI} \right) \quad (9)$$

which, for any given length  $l$  and cross-section, evidently reaches a maximum when  $\alpha = 45^\circ$ .

The component rotations of an element  $dl$  about the axis OX would similarly give the total rotation  $\theta = \frac{\delta}{R}$  and the deflection—

$$\delta = R\theta = WlR^2 \left( \frac{\cos^2 \alpha}{NJ} + \frac{\sin^2 \alpha}{EI} \right) \text{ as in (2)}$$

For a solid circular section of diameter  $d$ —

$$\phi = \frac{32WRl}{\pi d^4} \sin \alpha \cos \alpha \left( \frac{1}{N} - \frac{2}{E} \right) \text{ or } \frac{64WR^2 n}{d^4} \sin \alpha \left( \frac{1}{N} - \frac{2}{E} \right) \text{ radians} \quad (10)$$

which when  $\frac{N}{E} = \frac{2}{5}$  is evidently positive.

For non-circular sections, instead of  $\frac{1}{J}$  in the above expressions, the coefficients of  $\frac{Tl}{N}$ , given in (2), (4), and (6), Art. 112, may be used; in such sections as ellipses and rectangles, of which the principal cross-dimensions are very unequal, the torsional and flexural rigidities may differ greatly while in the circular section—

$$\frac{NJ}{EI} = \frac{4}{5}$$

when  $\frac{N}{E} = \frac{2}{5}$ . In the case of such elongated sections the rotation  $\phi$  may be much larger than for a circular section, and may be positive or negative.<sup>1</sup>

<sup>1</sup> See a paper on the theory of such springs by Profs. Ayrton and Perry, *Proc. Roy. Soc.*, vol. 36, 1884.

The intensity of the greatest principal stress may be estimated by (3), Art. 113. The component stress  $f$  results from a bending moment  $WR \sin \alpha$ , and the component  $f_s$  from a twisting moment  $WR \cos \alpha$ ,  $f_s$  for non-circular sections being calculated as in Art. 112. For circular sections the principal stress by (4), Art. 113, reduces to—

$$f_1 = \frac{16}{\pi d^3} WR(1 + \sin \alpha) \dots \dots \dots (11)$$

The maximum intensity of shear stress is—

$$\frac{16}{\pi d^3} \sqrt{W^2 R^2 \cos^2 \alpha + W^2 R^2 \sin^2 \alpha} = \frac{16WR}{\pi d^3}$$

as for a closely coiled spring.

(2) *Axial Torque M.*—The moment about OY, reckoned positive if it tends to increase  $\phi$ , *i.e.* to increase the curvature of the coils, may be split into components  $M \cos \alpha$  about OY' and  $M \sin \alpha$  about OX', as before, and the equation of resilience becomes—

$$\frac{1}{2} M \phi = \frac{1}{2} \frac{I M^2 \cos^2 \alpha}{EI} + \frac{1}{2} \frac{I M^2 \sin^2 \alpha}{NJ} \dots \dots \dots (12)$$

$$\phi = I M \left( \frac{\cos^2 \alpha}{EI} + \frac{\sin^2 \alpha}{NJ} \right) = 2\pi R n M \sec \alpha \left( \frac{\cos^2 \alpha}{EI} + \frac{\sin^2 \alpha}{NJ} \right) (13)$$

the modification of J for non-circular sections being as before in accordance with Art. 112, and for a circular wire of diameter  $d$ —

$$\phi = \frac{32 I M}{\pi d^4} \left( \frac{2 \cos^2 \alpha}{E} + \frac{\sin^2 \alpha}{N} \right) = \frac{64 MR}{d^4} n \sec \alpha \left( \frac{2 \cos^2 \alpha}{E} + \frac{\sin^2 \alpha}{N} \right) (14)$$

which reduces to the form (8), Art. 117, when  $\alpha = 0$ .

Taking  $\frac{N}{E} = \frac{2}{6}$ , this exceeds the value for  $\alpha = 0$  and the *same length of wire* by under 1 per cent. when  $\alpha = 10^\circ$ , and by  $12\frac{1}{2}$  per cent. when  $\alpha = 45^\circ$ .

The axial extension caused by the couple M may be found by resolving the rotations as before. The result for circular sections is—

$$\delta = M/R \sin \alpha \cos \alpha \left( \frac{1}{NJ} - \frac{1}{EI} \right) \dots \dots (15)$$

and for a solid round wire of diameter  $d$ —

$$\delta = \frac{32 I MR}{\pi d^4} \sin \alpha \cos \alpha \left( \frac{1}{N} - \frac{2}{E} \right) \text{ or } \frac{64 MR^2}{d^4} \sin \alpha \left( \frac{1}{N} - \frac{2}{E} \right) (16)$$

the modifications in (15) for non-circular sections being as before.

The various formulæ derived in this article must be regarded as approximations only, because R and  $\alpha$  have been treated as constants: actually they are variables which are changed by changes in axial length and by twist according to the obvious relations—

$$\begin{aligned} \text{axial length of coil} &= l \sin \alpha \\ 2\pi nR &= l \cos \alpha \end{aligned}$$

The deflection  $\delta$  is the change in axial length, and the twist  $\phi$  is the change in  $2\pi n$ ; for small deflections and twists, however, the changes in  $\alpha$  and  $R$  may be neglected, and the formulæ given are nearly exact.

**EXAMPLE 1.**—A closely coiled helical spring is made of  $\frac{1}{2}$ -inch round steel, and its ten coils have a mean diameter of 10 inches. Find the elongation, intensity of torsional stress, and resilience per cubic inch when the spring carries an axial load of 40 pounds.  $N = 12 \times 10^6$  lbs. per square inch.

The twisting moment about the axis of the wire is—

$$40 \times 5 = 200 \text{ lb.-inches}$$

The angle of twist consequently is—

$$\frac{200 \times 10\pi \times 10}{12 \times 10^6 \times \frac{1}{16} \times \frac{\pi}{3^2}} = \frac{64}{75} \text{ radian}$$

and the deflection is—

$$\frac{64}{75} \times 5 = 4\frac{4}{15} \text{ inches}$$

The intensity of shear stress is—

$$f_s = \frac{200 \times 16 \times 8}{\pi} = 8150 \text{ lbs. per square inch}$$

The resilience per cubic inch is—

$$\frac{1}{4} \times \frac{f_s^2}{N} = \frac{1}{4} \cdot \frac{8150 \times 8150}{12 \times 10^6} = 1.38 \text{ inch-pounds}$$

**EXAMPLE 2.**—Find the axial twist, intensity of bending stress, and work stored per cubic inch in the spring in Ex. 1 if an axial torque of 125 lb.-inches is applied.  $E = 30 \times 10^6$  lbs. per square inch.

The angle of twist—

$$\phi = \frac{Ml}{EI} = \frac{125 \times 10\pi \times 10 \times 64 \times 16}{30 \times 10^6 \times \pi} = \frac{64}{150} \text{ radian} = 24.45 \text{ degrees}$$

The intensity of bending stress is—

$$f = \frac{32M}{\pi d^3} = \frac{32 \times 125 \times 8}{\pi} = 10,180 \text{ lbs. per square inch}$$

and the resilience per cubic inch is—

$$\frac{1}{8} \frac{f^2}{E} = \frac{(10,180)^2 \times 10^6}{8 \times 30 \times 10^6} = 0.432 \text{ inch-pound}$$

**EXAMPLE 3.**—Find the deflection and the angular twist of the free end of a helical spring of ten coils 10 inches diameter, made of  $\frac{1}{2}$ -inch

round steel, due to an axial load of 40 lbs., if the helix makes an angle of  $60^\circ$  with the axis (*i.e.*  $\alpha = 30^\circ$ ). Estimate also the greatest intensity of stress in the material.

Using the results of the simpler case of Ex. 1 and of (3), Art. 118—

$$\begin{aligned}\delta &= \frac{4}{41\frac{1}{2}} \times \sec 30^\circ \left( \cos^2 30^\circ + \frac{2}{2.5} \sin^2 30^\circ \right) \\ &= \frac{6.4}{1\frac{1}{2}} \times 1.155(0.75 + 0.2) = 4.68 \text{ inches}\end{aligned}$$

(Note that the length of wire is 15.5 per cent. greater than in Ex. 1.) And from (10), Art. 118—

$$\phi = \frac{128 \times 40 \times 25 \times 10 \times 16}{12 \times 10^6} \times \frac{1}{2} \left( 1 - \frac{2}{2.5} \right) = \frac{6.4}{37\frac{1}{2}} \text{ radian} = 9.8 \text{ degrees}$$

From (11), Art. 118, the maximum principal stress intensity is—

$$\frac{16 \times 200 \times 8}{\pi} \left( 1 + \frac{1}{2} \right) = 8160 \times 1.5 = 12,240 \text{ lbs. per square inch}$$

EXAMPLE 4.—A helical spring is made from a flat strip of steel 1 inch wide and  $\frac{1}{10}$  inch thick, the thickness being perpendicular to the axis of the helix. The mean diameter of the coils, of which there are five, is 4 inches, and their pitch is 10 inches. If the upper end is held firmly, estimate approximately the rotation of the lower end per pound of axial load. Take the values of N and E given in Exs. 1 and 2.

If  $\alpha$  is the angle which the coils make with the horizontal when the axis is vertical—

$$\tan \alpha = \frac{\text{pitch}}{\text{mean circumference}} = \frac{10}{4\pi} = 0.797$$

hence  $\sin \alpha = 0.623$

Then in (9), Art. 118, instead of  $\frac{I}{J}$ , (6), Art. 112, may be used, viz.

$\frac{40J}{A^4}$ , and J for a rectangle  $b$  by  $d$  is  $\frac{1}{12}bd(b^2 + d^2)$ , hence—

$$J = \frac{1}{12} \times \frac{1}{10} (1.01) = \frac{1.01}{120} \quad \text{while} \quad A = \frac{1}{10}$$

$$\frac{40J}{A^4} = \frac{40 \times 1.01 \times 10,000}{120} = \frac{10,100}{3}$$

$$\text{Also} \quad I = \frac{1}{12}bd^3 = \frac{1}{12,000}$$

hence, from (9), Art. 118, the angle of twist for 1-lb. load is—

$$\begin{aligned}\phi &= \frac{2\pi \times 4 \times 5 \times 0.623}{10^6} \left( \frac{10,100}{3 \times 12} - \frac{12,000}{30} \right) \\ &= \frac{2\pi \times 4 \times 5 \times 0.623}{12 \times 10^6} (3367 - 4800) = -0.00935 \text{ radian} = -0.535 \text{ degree}\end{aligned}$$

The negative sign denotes that the spring *unwinds*.

EXAMPLE 5.—Find the weight of a closely coiled helical spring of round steel necessary to take a safe load of 500 lbs. with an elongation of 2 inches, the safe intensity of shear stress being 50,000 lbs. per square inch, and  $N = 12 \times 10^6$  lbs. per square inch, the weight of steel being 0.28 lb. per cubic inch.

The proof resilience per cubic inch is—

$$\frac{1}{4} \cdot \frac{f_s^2}{N} = \frac{2500 \times 10^6}{4 \times 12 \times 10^6} = 52.1 \text{ inch-pounds}$$

Work to be stored =  $\frac{1}{2} \times 500 \times 2 = 500$  inch-pounds.

Cubic inches required,  $\frac{500}{52.1}$ .

$$\text{Weight of spring} = \frac{500 \times 0.28}{52.1} = 2.69 \text{ lbs.}$$

#### EXAMPLES X.

1. A steel shaft is 3 inches diameter, and the twist is not to exceed  $1^\circ$  in 5 feet length. To what maximum intensity of torsional stress does this correspond if  $N = 5200$  tons per square inch?

2. Find the twisting moment which will produce a stress of 9000 lbs. per square inch in a shaft 3 inches diameter. What is the angle of twist in 10 feet length if  $N = 12,000,000$  lbs. per square inch?

3. What diameter of shaft will be required to transmit 80 H.P. at 60 revolutions per minute if the maximum torque is 30 per cent. greater than the mean and the limit of torsional stress is to be 8000 lbs. per square inch? If  $N = 12,000,000$ , what is the maximum angle of twist in 10 feet length?

4. If a shaft 3 inches diameter transmits 100 H.P. at 150 revolutions per minute, find the greatest intensity of torsional stress, the maximum twisting moment being  $1\frac{1}{2}$  times the mean.

5. Find the maximum stress in a propellor shaft 16 inches external and 8 inches internal diameter when subjected to a twisting moment only of 1800 ton-inches. If  $N = 5200$  tons per square inch, how much is the twist in a length 20 times the diameter?

6. Compare (1) the torsional elastic strength, (2) the stiffness or torsional rigidity of the shaft in problem No. 5 with those of a solid round shaft of the same weight and length.

7. Compare (1) the weight and (2) the strength or moment of torsional resistance for the same maximum stress of the shaft in problem No. 5 with that of a round shaft which has the same torsional rigidity and is solid.

8. A shaft 4 inches diameter is at a certain section subject to a twisting moment of 40,000 lb.-inches and a bending moment of 30,000 lb.-inches. What is the maximum intensity of direct stress in the material, and what is the inclination of the greatest principal stress to the axis of the shaft?

9. What must be the diameter of a solid shaft to transmit a twisting moment of 160 ton-feet and a bending moment of 40 ton-feet, the maximum direct stress being limited to 4 tons per square inch? What should be the external diameter of a hollow shaft to do this if the internal diameter is 0.6 of the external diameter?

10. A shaft  $2\frac{1}{2}$  inches diameter is subjected to a bending moment of 6 ton-inches. If it runs at 100 revolutions per minute, what horse-power can it transmit without the greatest direct stress exceeding 5 tons per square inch?

11. A propellor shaft of solid section is 10 inches diameter and transmits 1200 H.P. at 90 revolutions per minute; if the thrust of the screw is 10 tons, estimate the maximum intensity of compressive stress in the shaft where bending stresses are negligible.

12. If in the previous problem there is in addition a bending moment of 10 ton-feet, find the maximum intensity of compressive stress.

13. If a round bar of steel 1 inch diameter, supported at points 50 inches apart, deflects  $0.106$  inch under a central load of 60 lbs. and twists  $2.96$  degrees between two points 40 inches apart under a twisting moment of 1500 lb.-inches, find  $E$ ,  $N$ , and Poisson's ratio for the material.

14. A closely coiled helical spring made of  $\frac{1}{4}$ -inch round steel wire has ten coils of 4 inches mean diameter. Find its deflection under an axial force of 12 lbs. ( $N = 12 \times 10^6$  lbs. per square inch.) What is the maximum intensity of shear stress in the wire, and what is the stiffness of the spring in pounds per foot of deflection?

15. A closely coiled helical spring is to be made of  $\frac{1}{4}$ -inch wire ( $N = 12 \times 10^6$  lbs. per square inch), and is to deflect  $\frac{1}{20}$  inch per lb. of load; if the coils are made 3 inches diameter, what length of wire will be necessary?

16. Find the maximum safe load and deflection of a closely coiled helical spring made of  $\frac{1}{2}$ -inch square steel, having ten complete coils 2 inches mean diameter. ( $N = 12 \times 10^6$  lbs. per square inch. Maximum safe shear stress 50,000 lbs. per square inch.)

17. Find the necessary weight of a closely wound helical steel spring of round wire to stand a safe load of 3 tons, and give a deflection of 1 inch. ( $N = 5200$  tons per square inch; maximum safe stress 25 tons per square inch; weight of steel  $0.28$  lb. per cubic inch.)

18. If the mean diameter of the coils of the spring in the previous problem is 5 inches, find the length and diameter of the round steel of which it is to be made.

19. What twisting moment will be required to twist the spring of problem No. 14 through an angle of  $30^\circ$  about the axis of the helix? ( $E = 30 \times 10^6$  lbs. per square inch.)

20. A closely coiled helical spring is to be made of steel, square in section, and is required to stand an extreme couple about its axis of 500 lb.-inches and to twist through  $360^\circ$  for this twisting moment. Estimate the necessary length and thickness of the wire to construct the spring. ( $E = 30 \times 10^6$  lbs. per square inch. Bending stress not to exceed 60,000 lbs. per square inch.)

21. Helical springs 4 inches diameter and having ten complete coils are made of steel: (1)  $\frac{1}{4}$  inch diameter round; (2) elliptical section  $\frac{1}{2}$  inch by  $\frac{3}{8}$  inch, the smaller diameter being radial to the axis of the coil; (3)  $\frac{1}{4}$  inch square; and (4) rectangular section  $\frac{1}{2}$  inch wide and  $\frac{1}{8}$  inch thick, the thickness being radial to the axis of the coil. The coils in each case make an angle of  $30^\circ$  with a plane perpendicular to the axis of the coils. Find in each case the stretch due to an axial load of 12 lbs. ( $N = 12 \times 10^6$  and  $E = 30 \times 10^6$  lbs. per square inch.)

22. Find the rotation of the free ends of the springs in the previous problem.

23. Find the twist of the springs in problem No. 21 due to an axial torque of 15 lb.-inches.

## CHAPTER XI.

### PIPES, CYLINDERS, AND DISCS.

#### 119. Thin Cylindrical Shell with Internal Pressure.—*Hoop Tension.*—

When a very thin circular cylinder or pipe contains fluid under pressure, neglecting the weight of the fluid, it is subjected to uniform pressure normal to the walls, and this causes a tensile stress in the material in directions which are tangential to the perimeter of a transverse section, which is usually called circumferential or hoop tension. The intensity of the hoop tension is rather greater at the inner side of the wall than at the outer (see Art. 122), but where the wall is of a thickness which is small compared to the diameter of the shell the variation is negligible, and the stress may be taken as uniformly distributed. Let  $r$  be the internal radius and  $t$  the radial thickness of a thin seamless circular cylinder (Fig. 156) subject

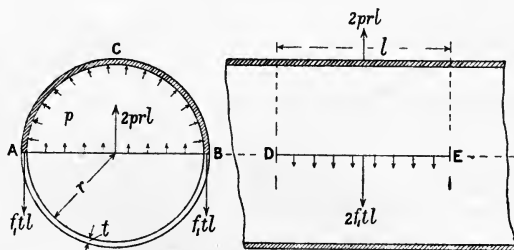

FIG. 156.

to an internal pressure of intensity  $p$ , which causes a hoop tension of intensity  $f_1$ . Consider the equilibrium of a half cylinder ABC of length DE or  $l$ . The walls not being subject to any shear stress, on planes perpendicular to the axis the total hoop tensions perpendicular to the diametral plane AB will be  $f_1 \cdot t \cdot l$  on each side of the cylinder as shown at A and B. These must just balance the resultant fluid pressure on the curved surface ACB, which is the same as that across the diametral plane AB, viz.  $p \times 2rl$ . Hence—

$$2f_1 \cdot l \cdot t = 2p \cdot r \cdot l \quad \dots \dots \dots (1)$$

and

$$f_1 = \frac{pr}{t} \quad \dots \dots \dots (2)$$

*Longitudinal Tension.*—The ends of a cylindrical shell may be connected by some form of stays parallel to the axis which resist wholly or in part the tendency of internal fluid pressure to force the ends apart, and so prevent or reduce longitudinal stress in the material of the shell ; in other cases the ends may be connected only by the material of the shell, and in this case the shell will have, in addition to the hoop tension  $f_1$ , a longitudinal tension of intensity, say  $f_2$ . The forces in an axial direction on any length of the cylinder, bounded by a closed end and a normal plane of cross-section FG (Fig. 157), are the axial thrust of the fluid pressure, which is independent of the shape of the end and is equal to  $p \cdot \pi r^2$ , and the total longitudinal tension  $f_2 \cdot 2\pi r t$ . Hence—

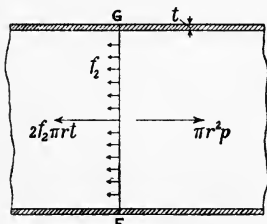

FIG. 157.

$f_2 \cdot 2\pi r t = p \cdot \pi r^2 \dots \dots \dots (3)$   
 $f_2 = \frac{pr}{2t} \dots \dots \dots (4)$

is independent of the shape of the end and is equal to  $p \cdot \pi r^2$ , and the total longitudinal tension  $f_2 \cdot 2\pi r t$ . Hence—

$$f_2 \cdot 2\pi r t = p \cdot \pi r^2 \dots \dots \dots (3)$$

$$f_2 = \frac{pr}{2t} \dots \dots \dots (4)$$

the intensity being just half that of the circumferential or hoop tension, *i.e.*—

$$f_2 = \frac{1}{2} f_1 \dots \dots \dots (5)$$

In addition to the two principal stresses  $f_1$  and  $f_2$  there is a third principal stress which is radial pressure, which varies from  $p$  at the inner side to zero at the outside of the shell. In *thin* shells this stress may generally be neglected in comparison with  $f_1$  and  $f_2$ . The circumferential strain  $e_1$  is evidently, by Art. 19—

$$e_1 = \frac{f_1}{E} - \frac{f_2}{mE} = \frac{f_1}{E} \left( 1 - \frac{1}{2m} \right) \text{ or } \frac{pr}{tE} \left( 1 - \frac{1}{2m} \right)$$

where  $\frac{1}{m}$  is Poisson's ratio, and E is the direct or stretch modulus of elasticity, and—

$$E \cdot e_1 = f_1 \left( 1 - \frac{1}{2m} \right)$$

which reduces to  $\frac{7}{8} f_1$  if  $m = 4$ .

The longitudinal strain  $e_2$  is—

$$e_2 = \frac{f_2}{E} - \frac{f_1}{mE} = \frac{f_2}{E} \left( 1 - \frac{2}{m} \right) \text{ or } \frac{f_1}{E} \left( \frac{1}{2} - \frac{1}{m} \right) \text{ or } \frac{pr}{2tE} \left( 1 - \frac{2}{m} \right)$$

$$E \cdot e_2 = f_2 \left( 1 - \frac{2}{m} \right)$$

which reduces to  $\frac{1}{2} f_2$  when  $m = 4$ . Evidently, according to the "greatest strain" theory of elastic strength (see Art. 25), the longitudinal stress strengthens the shell in a circumferential direction.



The radius increases in the same proportion ( $e_1$ ) as the circumference, and the proportional increase of capacity or the volume enclosed by the shell is therefore—

$$2e_1 + e_2 \quad \text{or} \quad \frac{\phi r}{tE} \left( \frac{5}{2} - \frac{2}{m} \right)$$

*Oval Cylinders.*—In thin cylinders of any oval section, such as an elliptical cylinder, the intensity of hoop tension varies from point to point along the periphery. In addition, the oval section tends to become circular, a bending moment tending to increase the curvature acting in the neighbourhood of points of minimum curvature such as B and D in Fig. 158, and a bending moment of opposite sign acting at points of maximum curvature such as A and C. The hoop tension at A and C is found just as in (1) and (2) to be—

$$\frac{\phi \times OA}{t}$$

and at B and D is similarly—

$$\frac{\phi \times OB}{t}$$

and, as in (3) and (4), the longitudinal tension is—

$$f_2 = \frac{\phi \times (\text{internal area of pipe})}{t \times (\text{perimeter of pipe})}$$

The bending moments reach their extreme values at A, B, C, and D, being alternately of opposite signs at those four points, and passing through zero between two consecutive points. A simple graphical method of finding the bending moment and shearing force and tension at different points in the perimeter of such a pipe or cylinder is given by Mr. A. T. Weston in the *Engineer*, Sept. 23, 1904.

**120. Seams in Thin Shells.**—Very frequently, as in pipes of large diameter and steam boilers, cylindrical shells are not seamless, but are constructed of plates curved to the correct radius and connected by riveted joints. The strength of a riveted joint cannot be calculated with any great accuracy, as the distribution of stress is very complex, when stresses in the rivets and plates are calculated the average stress is generally understood. The proportions and pitch of the rivets are not always fixed from considerations of strength alone, and the proper arrangement of such joints, based on rules formed from experience,

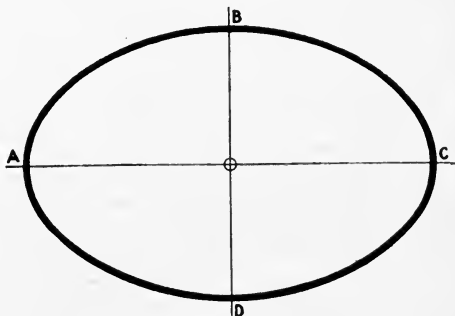

FIG. 158.

belongs to the subject of design of structures and machines.<sup>1</sup> Neglecting any frictional resistance of the riveted joint, the average tensile stress at the minimum section in the plate perforated to receive the rivets is greater than in the solid plate in the same ratio that the section of the solid plate is greater than the smallest section of the perforated plate perpendicular to the direction of tension.

In a cylindrical shell exposed to internal pressure having circumferential and longitudinal seams, evidently the area of section perpendicular to the direction of tension may be reduced more in the circumferential seams, which resist the longitudinal tension, than in the longitudinal seams which resist the circumferential tension, the intensity of the latter (in the solid plate) being twice that of the former. Hence circumferential riveted joints are often made of much lower efficiency than longitudinal ones, the *efficiency* being the ratio of the strength of the joint to that of a corresponding width of seamless plate.

*Helical Seams.*—The weakest part of a thin cylindrical shell being the longitudinal seams, it might evidently be made stronger with regard to internal pressure by making all the seams inclined to the axis of the cylinder. If  $\theta$  is the inclination of a helix on the cylindrical surface to the plane of a transverse section, or  $90^\circ - \theta$  the inclination to the axis of the cylinder, the intensity of normal stress across the helix is, by Art. 15 (1), with the notation of Art. 120—

$$f_2 \cos^2 \theta + f_1 \sin^2 \theta \quad \text{or} \quad f_1 \left( \frac{1}{2} \cos^2 \theta + \sin^2 \theta \right)$$

and the intensity of the resulting stress which is oblique to the helix, by Art. 15 (3), is—

$$\sqrt{f_1^2 \cos^2 \theta + f_2^2 \sin^2 \theta}$$

**121. Thin Spherical Shell with Internal Pressure.**—The forces across a diametral plane are the same as those across a transverse section of a cylinder perpendicular to its axis, and if  $r$  is the radius of the sphere,  $p$  the intensity of internal pressure, and  $f$  the intensity of tension in the shell of thickness  $t$ , as in (3), Art. 119—

$$f \times 2\pi r t = p \times \pi r^2$$

$$f = \frac{pr}{2t}$$

This is the direction of stress in every direction tangential to the spherical shell, the ellipse of stress being a circle. The circumferential strain in every direction, neglecting radial compressive stress in the shell, is evidently—

$$e = \frac{f}{E} \left( 1 - \frac{1}{m} \right)$$

and

$$Ee = f \left( 1 - \frac{1}{m} \right) = \frac{pr}{2t} \left( 1 - \frac{1}{m} \right)$$

<sup>1</sup> For a discussion of the points involved in the design of riveted joints, see Unwin's "Machine Design," vol. i.

The proportional increase of radius is  $e$ , and of the enclosed volume is  $3e$  or  $\frac{3pr}{2tE} \left( 1 - \frac{1}{m} \right)$

**122. Thick Cylinder subject to Fluid Pressure.**—The intensities of the circumferential and of the radial stress in a thick cylinder of homogeneous and isotropic material can be calculated if simple assumptions are made. The following theory is due to Lamé:—

Let  $R_2$  and  $R_1$  respectively be the internal and external radii (Fig. 159), and let  $p_2$  and  $p_1$  be the internal and external pressure intensities. Let  $p_x$  and  $p_y$  be the intensities of radial compressive stress and circumferential tension respectively at any variable radius  $x$ , the third principal stress being parallel to the axis of the cylinder. Then, considering the equilibrium of half of any very thin cylindrical element of radius  $x$ , thickness  $\delta x$ , and, say, length  $l$  (Fig. 160), as in (1), Art. 119,

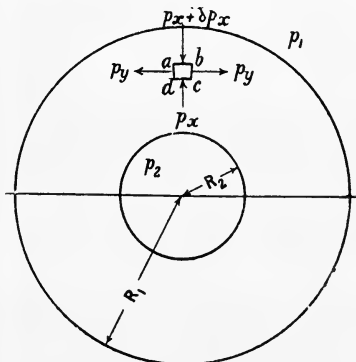

FIG. 159.

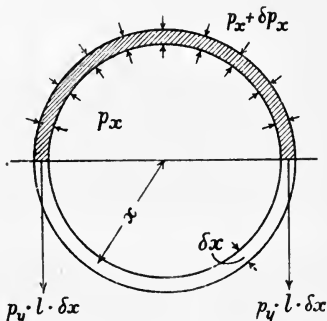

FIG. 160.

the outward pressure on the curved surface, *i.e.* the outward resultant of the pressure on inside and outside, must be equal to the total hoop tension across a diametral plane, or—

$$(p_x \times 2xl) - (p_x + \delta p_x)2(x + \delta x)l = 2p_y \cdot l \cdot \delta x - p_x \cdot \delta x - x\delta p_x - \delta x\delta p_x = p_y \cdot \delta x$$

and in the limit when the thickness of the element is reduced indefinitely—

$$p_y = -p_x - x \frac{dp_x}{dx} = -\frac{d}{dx}(p_x \cdot x) \dots (1)$$

Another relation between  $p_x$  and  $p_y$  depends upon an assumption as to longitudinal strains. It is assumed that plane transverse sections remain plane under the pressure, an assumption which must be nearly true at a considerable distance from the ends, however the ends may be supported or even if they are free. This involves the longitudinal strain at any point in a cross-section being constant, *i.e.* independent of  $x$ . Now

if the longitudinal stress is uniformly distributed and its intensity is  $f_1$ , say, tensile, and the longitudinal strain is  $e$ , at any point distant  $x$  from the axis, by Art. 19—

$$e = \frac{1}{E} \left( f_1 - \frac{p_y - p_x}{m} \right)$$

which is constant with respect to  $x$  if cross-sections originally plane remain plane. And since  $e$ ,  $E$ ,  $f_1$ , and  $m$  are constants,  $p_y - p_x$  must be constant. Take

$$p_y - p_x = 2a \quad \dots \dots \dots (2)$$

and substitute for  $p_y$  its value from (1)—

$$\begin{aligned} -2p_x - x \frac{dp_x}{dx} &= 2a \\ \frac{dp_x}{p_x + a} &= -\frac{2dx}{x} \end{aligned}$$

Integrating,  $\log(p_x + a) = -\log x^2 + \text{constant}$

or, 
$$\begin{aligned} p_x + a &= \frac{b}{x^2} \\ p_x &= \frac{b}{x^2} - a \quad \dots \dots \dots (3) \end{aligned}$$

where  $b$  and  $a$  are constants to be determined from the known internal and external radial pressure and radius. Also from (2)—

$$p_y = \frac{b}{x^2} + a \quad \dots \dots \dots (4)$$

For the solution of numerical problems the equations (3) and (4) are the most convenient formulæ. Inserting the conditions  $p_x = p_1$  for  $x = R_1$  and  $p_x = p_2$  for  $x = R_2$ , as in Fig. 159—

$$b = \frac{R_1^2 R_2^2}{R_1^2 - R_2^2} (p_2 - p_1) \quad a = \frac{p_2 R_2^2 - p_1 R_1^2}{R_1^2 - R_2^2}$$

which may be substituted in (3) and (4) to give the most general expressions.

*Internal Pressure.*—If the internal pressure intensity is  $p_2$ , and the external pressure  $p_1$  is zero, as in hydraulic main pipes and cylinders, etc., (3) gives—

$$p_x = \frac{R_1^2 R_2^2}{R_1^2 - R_2^2} \cdot \frac{p_2}{x^2} - \frac{p_2 R_2^2}{R_1^2 - R_2^2} = p_2 \frac{R_2^2}{R_1^2 - R_2^2} \left( \frac{R_1^2}{x^2} - 1 \right) \quad (5)$$

$$p_y = p_2 \frac{R_2^2}{R_1^2 - R_2^2} \left( \frac{R_1^2}{x^2} + 1 \right) \quad \dots \dots \dots (6)$$

The manner in which the radial compressive stress  $p_x$  and the hoop tension  $p_y$  vary in a given case is shown in Fig. 161 (see Ex. 3 below),

which also shows the radial and hoop or circumferential strains which, according to the maximum strain theory, Art. 25, should be used as a measure of elastic strength. It has been assumed, in estimating the strains in Fig. 161, that the walls of the cylinder carry the whole end

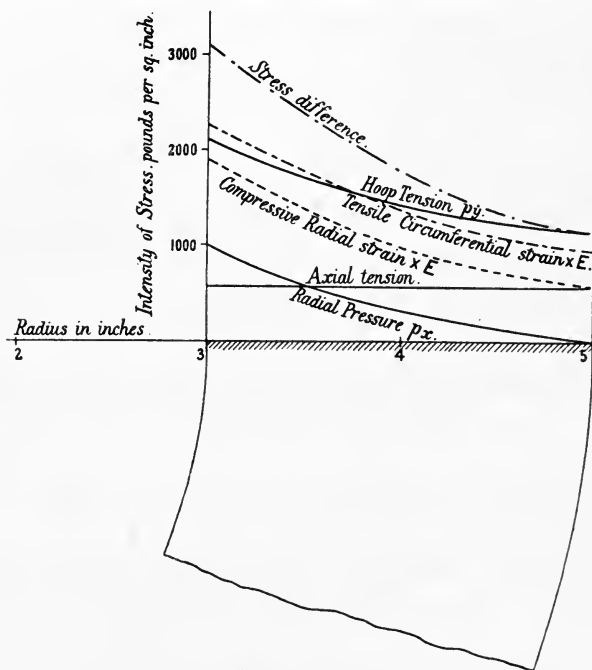

FIG. 161.--Stresses and strains in thick cylinder.

thrust of the internal pressure as a uniformly distributed tensile stress. The greatest algebraic difference of principal stresses is also shown in Fig. 161; according to the "maximum shear stress" theory of elastic strength (Art. 25), it is this greatest "stress difference" which determines elastic failure.

The greatest intensity of stress is the hoop tension at the inner surface of the tube where  $x = R_2$ , and is—

$$p_{y_2} = p_2 \frac{R_1^2 + R_2^2}{R_1^2 - R_2^2} \dots \dots \dots (7)$$

The greatest value of  $p_x$  is  $p_2$ , at the inner surface.

If the longitudinal stress  $f_1$  is zero, the greatest strain which occurs in the direction of the maximum hoop stress is—

$$e_{y_2} = \frac{p_{y_2}}{E} + \frac{p_2}{mE} = \frac{p_2}{E} \left( \frac{R_1^2 + R_2^2}{R_1^2 - R_2^2} + \frac{1}{m} \right)$$

and—

$$E \cdot \epsilon_{y_2} = p_1 \left( \frac{R_1^2 + R_2^2}{R_1^2 - R_2^2} + \frac{1}{m} \right) \text{ or } p_2 \left\{ \frac{R_1^2(m+1) + R_2^2(m-1)}{m(R_1^2 - R_2^2)} \right\} \quad (8)$$

which is greater than the value (7), and which, when  $m = 4$ , reduces to—

$$p_x \frac{5}{4} \frac{R_1^2 + \frac{3}{4} R_2^2}{R_1^2 - R_2^2} \dots \dots \dots (9)$$

If the cylinder wall carries the end pressure  $\pi R_2^2 p_2$ , taking  $f_1$  as uniform tension—

$$f_1 = p_2 \cdot \frac{R_2^2}{R_1^2 - R_2^2}$$

and in this case at the inner surface, by Art. 19—

$$\epsilon_{y_2} = \frac{p_{y_2}}{E} + \frac{p_2 - f_1}{mE}$$

and  $E \cdot \epsilon_{y_2} = p_2 \left\{ \frac{R_1^2(m+1) + R_2^2(m-2)}{m(R_1^2 - R_2^2)} \right\} \dots \dots \dots (10)$

which is less than (8).

*External Pressure.*—If the external pressure is  $p_1$ , and the internal pressure  $p_2$  is zero, using the constants  $a$  and  $b$  as found above—

$$p_x = -\frac{p_1}{x^2} \frac{R_2^2 R_1^2}{R_1^2 - R_2^2} + p_1 \frac{R_1^2}{R_1^2 - R_2^2} = p_1 \frac{R_1^2}{R_1^2 - R_2^2} \left( 1 - \frac{R_2^2}{x^2} \right) \quad (11)$$

$$p_y = -p_1 \frac{R_1^2}{R_1^2 - R_2^2} \left( 1 + \frac{R_2^2}{x^2} \right) \dots \dots \dots (12)$$

the negative sign denoting that the circumferential stress  $p_y$  is in this case compressive; it reaches its greatest magnitude when  $x = R_2$ , viz.—

$$\frac{2p_1 R_1^2}{R_1^2 - R_2^2}$$

**123. Thick Spherical Shell.**—If  $p_x$  is the radial compressive stress at any radius  $x$  and  $p_y$  the circumferential tensile stress, which in the spherical shell is equal in all directions perpendicular to the radius, an equation between the principal stresses  $p_x$  and  $p_y$  may be formed by considering the forces on an elementary spherical shell of radius  $x$  and thickness  $\delta x$  for—

$$\pi x^2 p_x - \pi (x + \delta x)^2 (p_x + \delta p_x) = 2\pi x \delta x \cdot p_y \dots \dots (1)$$

$$2p_y = -2p_x - x \cdot \frac{dp_x}{dx} \text{ or } -\frac{1}{x} \frac{d}{dx} (x^2 p_x) \dots \dots (2)$$

Another equation connecting  $p_x$  and  $p_y$  may be found from a consideration of the strain if we make a simple and reasonable assumption from the symmetry. If the displacement of every point in the shell is radial, it follows that the volumetric strain is the same everywhere, *i.e.* from Art. 19—

$$2e_y + e_x = \text{constant}^1$$

where  $e_y$  and  $e_x$  are the circumferential and radial tensile strains respectively (or  $2e_y$  is the superficial strain). Substituting in the equations of Art. 19, we find—

$$2p_y - p_x = \text{constant} = 3a \text{ (say)} \dots \dots (3)$$

Substituting the value  $3a + p_x$  for  $2p_y$  in (2)—

$$3(p_x + a) = -x \frac{dp_x}{dx} \dots \dots \dots (4)$$

$$\frac{dp_x}{p_x + a} = -3 \frac{dx}{x}$$

Integrating,

$$\log(p_x + a) = -\log x^3 + \text{constant (say } \log 2b)$$

$$p_x = \frac{2b}{x^3} - a$$

and substituting for  $p_x$  in (3),  $p_y = \frac{b}{x^3} + a$

The constants  $a$  and  $b$  are to be found as in the previous article from the known intensity of pressure at the inside and outside surfaces of the shell.

**124. Compound Cylinders.**—Fig. 161 shows that in a thick cylinder subject to internal pressure, while the metal near the inside of the tube may carry a heavy intensity of stress, that near the outside may only carry a much lower stress. A more uniform distribution under internal pressure may be obtained by giving the inner part of the metal an initial hoop pressure. This is attempted in various ways, one method being to shrink tubes on to smaller tubes, so producing a compound cylinder, the initial circumferential stress in the outer part being tensile, and that in the inner part being compressive. The state of stress when the compound tube sustains an internal fluid pressure is the algebraic sum of the initial stresses, and that resulting from the internal pressure as calculated in the previous article. The initial stress intensity anywhere may also be calculated as in the previous article. Considering a compound cylinder consisting of two tubes, one shrunk on to the other, if the inner radius be  $R_2$  and the outer one  $R_3$ , and at the junction the radius be  $R_1$ , for the inner tube—

$$p_x = \frac{b}{x^3} - a$$

$$p_y = \frac{b}{x^3} + a$$

<sup>1</sup> The reader may verify this after reading Art. 126 by writing—

$$e_y = \frac{u}{x} = \frac{1}{E} \left( \frac{m-1}{m} p_y + \frac{1}{m} p_x \right) \quad e_x = \frac{du}{dx} = \frac{1}{E} \left( -p_x - \frac{2}{m} p_y \right)$$

where  $u$  is the radial displacement at a radius  $x$ ; solving these equations and substituting the values of  $p_x$  and  $p_y$  in (2), we get an equation—

$$\frac{d^2u}{dx^2} + 2 \left( \frac{1}{x} \frac{du}{dx} - \frac{u}{x^2} \right) = 0$$

which, when integrated as in (11), Art. 126, gives—

$$\frac{du}{dx} + 2 \frac{u}{x} = e_x + 2e_y = \text{constant}$$

The stresses and strains may now be found as in Art. 126 or as in Art. 123.

$p_x$  being compressive and  $p_y$  being tensile when positive. Also for the outer tube, similarly—

$$p_x = \frac{b'}{x^2} - a'$$

$$p_y = \frac{b'}{x^2} + a'$$

$a'$  and  $b'$  being constants other than  $a$  and  $b$ .

The four conditions necessary to find the four constants may be stated as follows: (1)  $p_x = 0$  for  $x = R_2$ ; (2)  $p_x = 0$  for  $x = R_3$ ; (3)  $p_x$  for each tube has the same magnitude for  $x = R_1$ ; (4) the algebraic difference of the hoop-stress intensities for the two tubes at  $x = R_1$ , divided by  $E$  equals the original difference of radii at the junction radius  $R_1$  before shrinking, divided by  $R_1$ , or equals the algebraic difference of the hoop strains. If a value of  $p_x$  is assigned for  $x = R_1$  the conditions (3) and (4) are unnecessary. To explain condition (4) more fully, at the junction of the tubes the circumferential tensile strain of the outer tube is—

$$\frac{p_y}{E} + \frac{p_x}{mE}$$

and the original radius is therefore increased after the shrinking by an amount—

$$R_1 \left( \frac{p_y}{E} + \frac{p_x}{mE} \right) = R_1 \left\{ \left( \frac{b'}{R_1^2} + a' \right) \frac{1}{E} + \left( \frac{b'}{R_1^2} - a' \right) \frac{1}{mE} \right\}$$

The increase of radius of the inner tube at the radius  $R_1$  is similarly—

$$R_1 \left\{ \left( \frac{b}{R_1^2} + a \right) \frac{1}{E} + \left( \frac{b}{R_1^2} - a \right) \frac{1}{mE} \right\}$$

$a$  and  $b$  being in this case negative quantities, and the strain being compressive, the *decrease* of radius being—

$$- R_1 \left\{ \left( \frac{b}{R_1^2} + a \right) \frac{1}{E} + \left( \frac{b}{R_1^2} - a \right) \frac{1}{mE} \right\}$$

The total difference of original radii at junction is therefore—

$$\frac{R_1}{E} \left\{ \left( \frac{b'}{R_1^2} + a' \right) - \left( \frac{b}{R_1^2} + a \right) \right\}$$

since, by condition (3),  $\frac{b}{R_1^2} - a = \frac{b'}{R_1^2} - a'$

Hence condition (4) leads to the equation—

$$\frac{1}{E} \left( \frac{b' - b}{R_1^2} + a' - a \right) = \frac{\text{original difference of radius at } R_1}{R_1}$$

where  $a$  and  $b$  will be negative quantities (see Ex. 4 below).



EXAMPLE 1.—A steel pipe 6 inches internal diameter has to withstand an internal pressure of 400 pounds per square inch. Find the necessary thickness if the intensity of tensile stress is to be limited to 6000 pounds per square inch. If this tube is closely wound with a layer of round steel wire  $\frac{1}{20}$  inch diameter, having a uniform tension of 15,000 pounds per square inch before the pressure comes into the tube, find the mean intensity of stress in the metal of the tube and wire before and after the pressure of 400 pounds per square inch is in the pipe, (a) if no stress in the direction of the axis is borne by the pipe, (b) if all the stress in that direction is carried by the pipe. (Poisson's ratio =  $\frac{1}{4}$ .)

From (2), Art. 119, the pipe thickness—

$$t = \frac{400 \times 3}{6000} = 0.2 \text{ inch}$$

Number of complete coils of wire = 20 per inch length of pipe. The total tension across a 1-inch length of pipe is—

$$40 \times \frac{\pi}{4} \times \left(\frac{1}{20}\right)^2 \times 15,000 = 1178 \text{ pounds}$$

which causes a circumferential compressive stress in the material of the tube; the intensity of this stress is—

$$1178 \div (2 \times 0.2) = 2945 \text{ pounds per square inch}$$

(a) After the pressure is in the tube, the bursting forces across a diametral plane are resisted jointly by the wall of the tube and the winding, which, having practically the same strain and same modulus of elasticity, have the same change in intensity of stress. Per inch length of pipe the total force is—

$$400 \times 6 = 2400 \text{ pounds}$$

and the resisting area is—

$$(2 \times 0.2) + \left(40 \times \frac{\pi}{4} \times \frac{1}{400}\right) = 0.47854 \text{ square inch}$$

The change in intensity of stress is therefore—

$$2400 \div 0.47854 = 5015 \text{ pounds per square inch tension}$$

The tension in the tube will therefore be—

$$5015 - 2945 = 2070 \text{ pounds per square inch}$$

and the tension in the wire will be—

$$15,000 + 5015 = 20,015 \text{ pounds per square inch}$$

(b) If  $f$  is the change in hoop stress in the wall of the pipe due to the pressure, the longitudinal stress being, from (4), Art. 119, equal to 3000 pounds per square inch, and the hoop strains of the tube and wire being equal—

$$\frac{f}{E} - \frac{3000}{mE} = \frac{f'}{E} \quad \text{or} \quad f' = f - 750$$

where  $f'$  is the increase in tensile stress in the wire.

Hence, equating the total change of tension to the bursting pressure per inch length as before—

$$0.4 \times f + 0.07854 \times (f - 750) = 2400$$

$$f = \frac{2459}{0.4785} = 5139 \text{ pounds per square inch}$$

$$f' = 5139 - 750 = 4389 \text{ pounds per square inch}$$

The tension in the tube will therefore be—

$$5139 - 2945 = 2194 \text{ pounds per square inch}$$

and in the wire—

$$15,000 + 4389 = 19,389 \text{ pounds per square inch}$$

EXAMPLE 2.—A cylindrical boiler 7 feet internal diameter has to stand a pressure of 200 pounds per square inch, the plates being  $\frac{7}{8}$  inch thick. If the section of plate through the centres of a row of rivets in a longitudinal seam is 70 per cent. of that of the unperforated plate, find the average tensile stress in the plate at the joint.

For the full plate, as in Art. 119—

$$f_1 = \frac{200 \times 42 \times 8}{7} = 9600 \text{ pounds per square inch}$$

Where the plate is reduced to 70 per cent. of the full area the intensity will be—

$$9600 \times \frac{10}{7} = 13,714 \text{ pounds per square inch}$$

EXAMPLE 3.—A hydraulic main is 6 inches internal diameter and 2 inches thick, and the water pressure is 1000 pounds per square inch. Find the intensities of circumferential tension and radial compression at all points in the cross-section.

From (3), Art. 122, the intensity of radial pressure—

$$p_x = \frac{b}{x^2} - a$$

Putting  $p_x = 1000$  for  $x = 3$ , and  $p_x = 0$  for  $x = 5$ —

$$a = \frac{9000}{16} \quad b = \frac{225,000}{16}$$

hence 
$$p_x = \frac{9000}{16} \left( \frac{25}{x^2} - 1 \right)$$

and from (4), Art. 122, the intensity of hoop tension—

$$p_y = \frac{9000}{16} \left( \frac{25}{x^2} + 1 \right)$$

The values of  $p_x$  and  $p_y$  for all parts of the metal walls are shown in

Fig. 161. In calculating the radial and hoop strains, the end pressure has been assumed to cause a uniform axial tensile stress of  $1000 \times \frac{3^2}{5^2 - 3^2}$ , or 562 pounds per square inch. At the inner surface  $x = 3$ —

$$\begin{aligned} p_v &= \frac{9000}{16} \left( \frac{25}{9} + 1 \right) = 2126 \text{ pounds per square inch} \\ p_x &= 1000 \text{ pounds per square inch} \end{aligned}$$

At the outer surface  $x = 5$ —

$$p_v = \frac{9000}{16} (1 + 1) = 1125 \text{ pounds per square inch} \quad p_x = 0$$

EXAMPLE 4.—A compound tube is made by shrinking one tube on another, the final dimensions being: internal diameter, 4 inches; external diameter, 8 inches; diameter at the junction of the tubes, 6 inches. If the radial pressure at the common 3-inch radius is 2500 pounds per square inch, find the greatest hoop tension and hoop pressure in the compound cylinder. What difference must there be in the external diameter of the inner tube and internal diameter of the outer tube before shrinking on, and what is the least difference of temperature necessary to allow of the outer one passing over the inner one? If the compound tube is subjected to an internal pressure of 15,000 pounds per square inch, find the hoop stress at the inner, outer, and common surfaces. How much heavier would a single tube require to be in order to stand this pressure with the same maximum hoop tension? Take the coefficient of expansion as 0.000062 per degree F., and  $E = 30 \times 10^6$  pounds per square inch.

Using the equations of Art. 124, for the inner tube—

$$\begin{aligned} \text{hence} \quad p_x &= 0 \text{ for } x = 2 & p_x &= 2500 \text{ for } x = 3 \\ a &= -4500 & b &= -18,000 \end{aligned}$$

and for the outer tube—

$$\begin{aligned} \text{hence} \quad p_x &= 0 \text{ for } x = 4 & p_x &= 2500 \text{ for } x = 3 \\ a' &= \frac{22,500}{7} & b' &= \frac{360,000}{7} \end{aligned}$$

Inner tube—

$$\text{at } x = 2, p_v = -\frac{18,000}{4} - 4500 = -9000, \text{ i.e. } 9000 \text{ pounds per sq. inch compression.}$$

$$\text{at } x = 3, p_v = -\frac{18,000}{9} - 4500 = -6500, \text{ or } 6500 \text{ pounds per sq. inch compression.}$$

Outer tube—

$$\text{at } x = 3, p_v = \frac{360,000}{7 \times 9} + \frac{22,500}{7} = 8929 \text{ pounds per sq. inch (tensile)}$$

$$\text{at } x = 4, p_v = \frac{360,000}{7 \times 16} + \frac{22,500}{7} = 6429 \quad \text{''} \quad \text{''} \quad \text{''} \quad \text{''}$$

Circumferential tensile strain at 3-inch radius in outer cylinder—

$$\frac{8929}{30 \times 10^6} + \frac{1}{m} \frac{2500}{30 \times 10^6} = 0.0002976 + \frac{2500}{m \times 30 \times 10^6}$$

where  $\frac{1}{m}$  is Poisson's ratio.

Circumferential compressive strain at 3-inch radius in inner cylinder—

$$\frac{6500}{30 \times 10^6} - \frac{1}{m} \frac{2500}{30 \times 10^6} = 0.000216 - \frac{2500}{m \times 30 \times 10^6}$$

The total difference of original diameters at the junction surface would therefore require to be—

$$6(0.0002976 + 0.000216) = 6 \times 0.0005143 = 0.003086 \text{ inch}$$

The minimum temperature difference to allow of the outer passing over the inner tube would therefore be—

$$0.0005143 \div 0.0000062 = 83^\circ \text{ F.}$$

When the internal pressure of 15,000 pounds per square inch is exerted, using new constants  $a$  and  $b$ , as in Art. 122—

since  $p_x = 0$  for  $x = 4$  and  $p_x = 15,000$  for  $x = 2$   
 $a = 5000$   $b = 80,000$

and due to the internal pressure alone—

$$\begin{aligned} \text{at } x = 2, p_y &= \frac{80,000}{4} + 5000 = 25,000 \text{ pounds per square inch} \\ \text{,, } x = 3, p_y &= \frac{80,000}{9} + 5000 = 13,889 \text{ ,, ,, ,,} \\ \text{,, } x = 4, p_y &= \frac{80,000}{16} + 5000 = 10,000 \text{ ,, ,, ,,} \end{aligned}$$

Finally, taking account of the initial stresses due to shrinkage, the resultant hoop tensions are—

$$\begin{aligned} \text{at } x = 2, 25,000 - 9000 &= 16,000 \text{ pounds per square inch} \\ \text{,, } x = 3, 13,889 - 6500 &= 7389 \text{ ,, ,, ,, (inner tube)} \\ \text{,, } x = 3, 13,889 + 8929 &= 22,818 \text{ ,, ,, ,, (outer ,,)} \\ \text{,, } x = 4, 10,000 + 6429 &= 16,429 \text{ ,, ,, ,,} \end{aligned}$$

The variations of stress throughout the tube are shown in Fig. 162.

With a single tube and a maximum tensile stress of 22,818 pounds per square inch at the inner surface—

$$22,818 = \frac{b}{4} + a$$

$$15,000 = \frac{b}{4} - a$$

hence

$$b = 75,636 \quad a = 3909$$

At the outer surface  $p_x = 0 = \frac{75,636}{x^2} - 3909$ ,  $x^2 = 19.35$ .

The excess of weight in the single tube is—

$$\frac{x^2 - 16}{16 - 4} = \frac{3.35}{12} = 28 \text{ per cent. nearly}$$

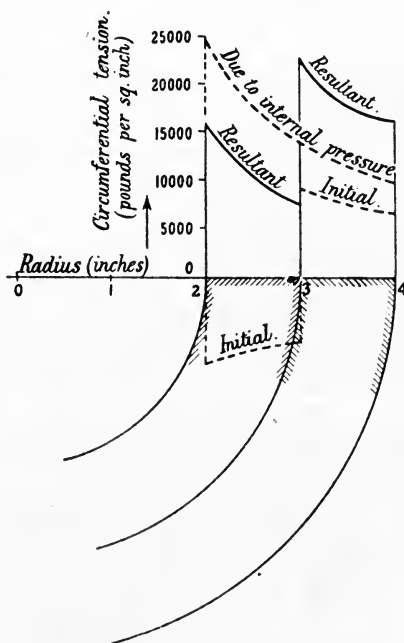

FIG. 162.

**125. Rotating Ring or Wheel Rim.**—A ring, when rotating about an axis through its centre of gravity, and perpendicular to its central plane, has induced in it a tension due to its inertia, and if the cross-sectional dimensions are small compared to its radius, this hoop tension is nearly uniform, as in the case of a thin cylindrical shell under internal pressure. Let  $r$  be the radius of the ring in inches. In order to rotate with uniform angular velocity  $\omega$  radians or linear velocity  $v$  inches per second, every point in the rim must have a radial inward acceleration  $\omega^2 r$  or  $\frac{v^2}{r}$  inches per second per second. If  $A$  is the area of cross-section in square inches, and  $w$  is the weight of the material per cubic inch, the radial inward force on a length of rim  $\delta s$  inches is—

$$\frac{w}{g} \frac{v^2}{r} A \delta s \text{ pounds}$$

where  $g$  is approximately  $32.2 \times 12$  inches per second per second. The normal force per unit length of arc is—

$$\frac{w}{g} \frac{v^2}{r} A \text{ pounds}$$

On a length of arc  $r\theta$ , or arc PQ (Fig. 163), the resultant radial inward force is—

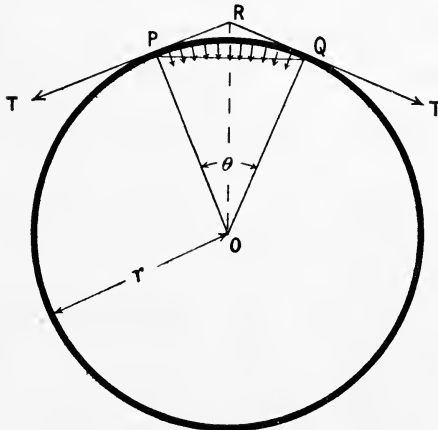

$$\frac{w}{g} \frac{v^2}{r} A \times \text{chord PQ}$$

$$\text{or } \frac{w}{g} \frac{v^2}{r} A \times 2r \sin \frac{\theta}{2}$$

along RO. This force is the resultant of the tension  $T$  at  $P$  and  $Q$ , hence, resolving these along  $RO$ —

$$2T \sin \frac{\theta}{2} = A \frac{w}{g} \frac{v^2}{r} \times 2r \sin \frac{\theta}{2}$$

$$\text{or, } T = A \frac{w}{g} v^2 \quad \text{or} \quad A \frac{w}{g} \omega^2 r^2$$

FIG. 163.

The intensity of tensile stress in the rim is therefore—

$$p = \frac{T}{A} = \frac{w}{g} v^2 = \frac{wv^2}{12 \times 32.2} \dots \dots \dots (1)$$

a result which also holds good for the “centrifugal tension” in a belt running on a pulley.

If  $f$  is the limit of safe stress for a wheel rim the limit of peripheral velocity is given by—

$$f = \frac{w}{g} v^2$$

$$v = \sqrt{\frac{fg}{w}} = \sqrt{\frac{f \times 12 \times 32.2}{w}} \text{ inches per second. } (2)$$

It is to be noted that for all the above formulæ if  $w$  is the weight per cubic *inch*, and the intensity is measured per square *inch*,  $v$  and  $g$  must be in inch units.

If  $v$  and  $g$  are in foot units (1) becomes—

$$p = \frac{12wv^2}{g} = \frac{12wv^2}{32.2} = 0.3722wv^2 \text{ pounds per square inch } (3)$$

EXAMPLE.—If the safe tensile stress in a cast-iron wheel rim is 1000 pounds per square inch, find the limit of peripheral velocity the weight of cast iron being 0.26 lb. per cubic inch.

From (2) above—

$$v = \sqrt{\frac{1000 \times 32.2 \times 12}{0.26}} \text{ inches per second}$$

or 102 feet per second (nearly).

**126. Rotating Disc.**<sup>1</sup>—The stresses in rotating circular discs and cylinders can be found approximately by making simple assumptions, and their approximate application to any part of the material can be justified. In the case of the circular disc rotating about its axis, we assume that the thickness of the disc is uniform and very small compared with its diameter. Stresses for a circular section of the disc will then hold approximately for any such section.

Evidently at the free flat faces there can be no stress normal to those faces, and there can be no shear stress on or perpendicular to that face. Hence the direction of the axis is, for all points on the originally flat surfaces, very nearly the direction of the axis of a principal stress of zero magnitude. Hence the radial and the hoop or circumferential stress are also principal stresses. (This also follows for the central plane, from the symmetry of the displacement of any point due to strain; the displacement must be radial.)

Let the intensity of the radial principal stress be  $p_x$ , and that of the circumferential or hoop stress be  $p_y$ , both being reckoned positive when tensile. Let  $t$  be the uniform axial thickness of the disc, and let  $R_1$  and  $R_2$  be the external and internal radii respectively (Fig. 164); let  $w$  be

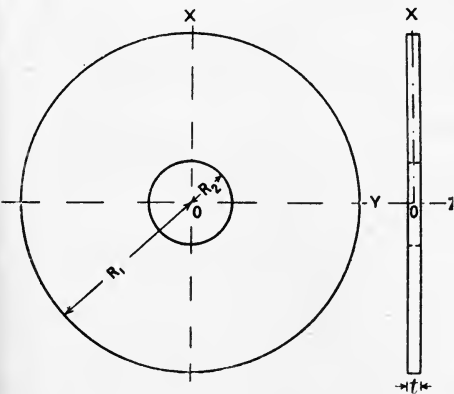

FIG. 164.

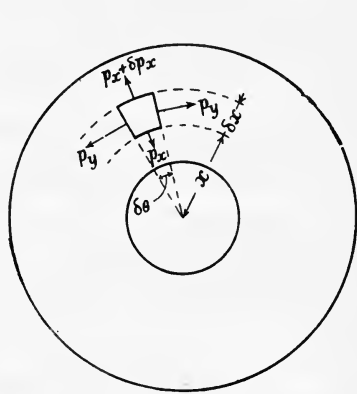

FIG. 165.

the weight of the material per unit volume, and  $\omega$  be the uniform angular velocity of rotation.

Consider the forces on a element of the disc at a radius  $x$ , Fig. 165,

<sup>1</sup> The solution of the disc problem here given is due to Grossman. For a rigid examination of the problem by the mathematical analysis of the strains, and further references, see a paper by Dr. Chree in the *Proc. of the Cambridge Philosophical Soc.*, vol. vii. pt. iv. (1891). See also a correspondence in *Nature*, 1891.

subtending an angle  $\delta\theta$  at the centre, and of radial width  $\delta x$ . The volume is  $x\delta\theta \times \delta x \times t$ , and the radial inward force in gravitational units, neglecting small quantities of the second order, is—

$$\frac{w}{g} \omega^2 x \cdot t \cdot x \delta\theta \cdot \delta x \quad . \quad . \quad . \quad . \quad . \quad . \quad (1)$$

This is equal to the resultant inward force exerted on the element by the (variable) radial and circumferential stresses  $p_x$  and  $p_y$ , viz. resolving as in the previous article—

$$t \left\{ p_y \cdot \delta x \cdot 2 \sin \frac{\delta\theta}{2} + p_x \cdot 2x \sin \frac{\delta\theta}{2} - (p_x + \delta p_x) 2(x + \delta x) \sin \frac{\delta\theta}{2} \right\}$$

or to the first order of small quantities—

$$t(p_y \delta x - p_x \delta x - x \delta p_x) \delta\theta \quad . \quad . \quad . \quad . \quad . \quad (2)$$

Equating (1) and (2) in the limit when  $\delta\theta$  is reduced indefinitely—

$$p_y = \frac{w}{g} \omega^2 x^2 + p_x + x \frac{dp_x}{dx} \quad \text{or} \quad \frac{w}{g} \omega^2 x^2 + \frac{d}{dx}(x p_x) \quad . \quad (3)$$

Considering the strains, if owing to the purely radial displacements of points in the central circular section the radius  $x$  increases to  $x + u$ , the circumferential strain is evidently—

$$\frac{2\pi(x + u) - 2\pi x}{2\pi x} = \frac{u}{x} \quad . \quad . \quad . \quad . \quad . \quad (4)$$

The radial width of this element is evidently after strain—

$$x + \delta x + u + \delta u - (x + u) = \delta x + \delta u$$

and the radial strain, which is tensile if positive, is the limiting value of—

$$\frac{\delta x + \delta u - \delta x}{\delta x} = \frac{du}{dx} \quad . \quad . \quad . \quad . \quad . \quad (5)$$

Hence from (1) of Art. 19 and (4) and (5) above, the principal stress in direction of the axis being zero, in the direction of  $p_y$  (circumferentially)—

$$\frac{u}{x} = \frac{1}{E} \left( p_y - \frac{p_x}{m} \right) \quad . \quad . \quad . \quad . \quad . \quad (6)$$

where  $\frac{1}{m}$  is Poisson's ratio.

And in the direction of  $p_x$  (radially)—

$$\frac{du}{dx} = \frac{1}{E} \left( p_x - \frac{p_y}{m} \right) \quad . \quad . \quad . \quad . \quad . \quad (7)$$



Solving the simultaneous simple equations (6) and (7)—

$$p_y = \frac{Em}{m^2 - 1} \left( m \frac{u}{x} + \frac{du}{dx} \right) \dots \dots \dots (8)$$

$$p_z = \frac{Em}{m^2 - 1} \left( \frac{u}{x} + m \frac{du}{dx} \right) \dots \dots \dots (9)$$

Substituting for  $p_y$  and  $p_z$  in (3)—

$$x \frac{d^2u}{dx^2} + \frac{du}{dx} - \frac{u}{x} = -\frac{w}{g} \omega^2 \frac{m^2 - 1}{m^2 E} x^2 \dots \dots \dots (10)$$

or, 
$$\frac{d^2u}{dx^2} + \frac{1}{x} \frac{du}{dx} - \frac{u}{x^2} = -\frac{w}{g} \omega^2 \frac{m^2 - 1}{m^2 E} x \dots \dots \dots (11)$$

To find the complementary function of (11)<sup>1</sup>—

$$\frac{d^2u}{dx^2} + \frac{1}{x} \frac{du}{dx} - \frac{u}{x^2} = \frac{d^2u}{dx^2} + \frac{d}{dx} \left( \frac{u}{x} \right) = 0$$

which on integration gives—

$$\frac{du}{dx} + \frac{u}{x} = \text{constant} = 2A \text{ (say)} \dots \dots \dots (12)$$

or, 
$$x \frac{du}{dx} + u = 2Ax$$

And integrating again—

$$ux = Ax^2 + B$$

hence 
$$\frac{u}{x} = A + \frac{B}{x^2} \dots \dots \dots (13)$$

and from (12) or (13)—

$$\frac{du}{dx} = A - \frac{B}{x^2} \dots \dots \dots (14)$$

To find a particular integral of equation (10),<sup>2</sup> assume—

$$u = Cx^2$$

Differentiating this twice and substituting in (10) gives—

$$C = -\frac{w}{g} \frac{\omega^2}{8E} \cdot \frac{m^2 - 1}{m^2}$$

and since  $\frac{u}{x} = Cx$  and  $\frac{du}{dx} = 3Cx$ , the complete solution of (10) is—

$$\frac{u}{x} = A + \frac{B}{x^2} - \frac{w}{g} \frac{\omega^2}{8E} \frac{m^2 - 1}{m^2} x^2 \dots \dots \dots (15)$$

$$\frac{du}{dx} = A - \frac{B}{x^2} - \frac{3w}{g} \frac{\omega^2}{8E} \cdot \frac{m^2 - 1}{m^2} \cdot x^2 \dots \dots \dots (16)$$

<sup>1</sup> Or see Lamb's "Infinitesimal Calculus," Art. 191.

<sup>2</sup> *Ibid*

Substituting these values in (9)—

$$p_x = \frac{Em}{m^2 - 1} \left\{ (m + 1)A - (m - 1) \frac{B}{x^2} - (3m + 1) \frac{w}{g} \frac{\omega^2}{8E} \frac{m^2 - 1}{m^2} x^2 \right\} \quad (17)$$

from which A and B may be found if the values of  $p_x$  are known for two radii.

*Disc with Central Hole.*—The condition necessary to determine A and B for a disc with a central hole are  $p_x = 0$  for  $x = R_1$  and  $p_x = 0$  for  $x = R_2$ . Substituting these values in (17), and solving the simple equations for A and B—

$$A = \frac{w}{g} \frac{\omega^2}{8E} \frac{(3m + 1)(m - 1)}{m^2} (R_1^2 + R_2^2)$$

$$B = \frac{w}{g} \frac{\omega^2}{8E} \frac{(3m + 1)(m + 1)}{m^2} R_1^2 R_2^2$$

Substituting these in (17)—

$$p_x = \frac{w}{g} \frac{\omega^2}{8m} (3m + 1) \left( R_1^2 + R_2^2 - \frac{R_1^2 R_2^2}{x^2} - x^2 \right) \quad (18)$$

and from (8), substituting for  $\frac{u}{x}$  and  $\frac{du}{dx}$  from (15) and (16)—

$$p_y = \frac{w}{g} \frac{\omega^2}{8m} \left\{ (3m + 1) \left( R_1^2 + R_2^2 + \frac{R_1^2 R_2^2}{x^2} \right) - (m + 3)x^2 \right\} \quad (19)$$

The value of  $p_y$  is always positive, and it decreases continuously with increase of  $x$ . Its greatest value, at  $x = R_2$  is—

$$p_y (\text{max.}) = \frac{w}{g} \frac{\omega^2}{4m} \{ (3m + 1)R_1^2 + (m - 1)R_2^2 \} \quad (20)$$

In cases where  $R_2$  is very small this approaches the value—

$$\frac{w}{g} \frac{\omega^2}{4m} (3m + 1)R_1^2 \quad \dots \quad (21)$$

and when  $R_2$  approaches  $R_1$ , it approaches the form (1), Art. 125.

The value of  $p_x$ , which is zero at  $x = R_1$  and  $x = R_2$ , is positive (*i.e.* tensile) for all values of  $x$  between  $R_1$  and  $R_2$ .

$$\frac{dp_x}{dx} \propto \left( \frac{2R_1^2 R_2^2}{x^3} - 2x \right), \text{ which is zero for } x = \sqrt{R_1 R_2}$$

at which radius the radial tension is a maximum, viz.—

$$(\text{max.}) p_x = \frac{w}{g} \frac{\omega^2}{8m} (3m + 1) (R_1 - R_2)^2$$

*Solid Disc.*—When the disc has no central hole the conditions which determine A and B in (15) are  $p_x = 0$  for  $x = R_1$  and  $u = 0$  for  $x = 0$ .

The latter from (15) gives  $B = 0$ , and then the former condition in (17) gives—

$$A = \frac{w}{g} \frac{\omega^2}{8E} \frac{(3m+1)(m-1)}{m^2} R_1^2$$

Hence from (8)—

$$p_y = \frac{w}{g} \frac{\omega^2}{8m} \{(3m+1)R_1^2 - (m+3)x^2\} \dots (22)$$

This is a maximum at the centre, where  $x = 0$ , viz.—

$$p_y (\text{max.}) = \frac{w}{g} \frac{\omega^2}{8m} (3m+1)R_1^2 \quad \text{or} \quad \frac{3m+1}{8m} \frac{w}{g} (\omega R_1)^2 \quad (23)$$

or just half the amount of the expression (21) for the greatest intensity of hoop stress in a disc with a very small hole through the centre, and  $\frac{3m+1}{8m}$  times that in a thin rim with the same peripheral velocity (see (1), Art. 125).

From (9) the radial stress intensity is—

$$p_x = \frac{w}{g} \frac{\omega^2}{8m} (3m+1)(R_1^2 - x^2) \dots (24)$$

This is always positive, and decreases continuously from the centre to the outer edge; its greatest value at the centre is—

$$p_x (\text{max.}) = \frac{w}{g} \frac{\omega^2}{8m} (3m+1)R_1^2$$

the same intensity as the greatest hoop tension. The expressions (22) and (24) may be obtained from (19) and (18) respectively by omitting every term containing  $R_2$ .

The general variation of intensity of the principal stresses  $p_y$  and  $p_x$  in a rotating disc is very similar to that of the corresponding stresses in a rotating cylinder shown in Figs. 166 and 167.

*Numerical Values.*—In estimating numerical values a caution is required, as in the previous article, if inch units are used for the dimensions, stress intensities, and weight per unit volume; in this case  $g$  must be taken as about  $32.2 \times 12$  (inches per second per second).

The value of  $m$ , as mentioned in Art. 12, varies between 3 and 4 for most metals. In estimating stress intensities by the above formulæ, the error is on the safe side if  $m = 3$  be adopted. This value is approximately correct for cast iron; for steel  $m = 4$  is probably more correct.

For steel, using inch units and  $w = 0.28$  lb. per cubic inch,  $m = 4$ , and  $n =$  revolutions per minute, (20) becomes—

$$p_y (\text{max.}) = (6.46R_1^2 + 1.49R_2^2) \times n^2 \times 10^{-6} \text{ pounds per sq. inch} \quad (25)$$

and (23) becomes—

$$p_x (\text{max.}) = 3.23n^2R_1^2 \times 10^{-6} \text{ pounds per square inch} \quad \dots (26)$$

127. **Rotating Cylinder.**<sup>1</sup>—An approximate solution of the problem of finding the intensities of stress in a cylinder rotating about its axis may be found by making a few simple assumptions. We shall confine ourselves to the stresses about the region of the central circular section perpendicular to the axis of a cylinder, the length of axis being great compared to the radius. At any point in the central cross-section let the direction of  $x$  be radially outwards from the axis; the direction of  $z$  parallel to the cylinder axis, and that of  $y$  be perpendicular to the other two. Let  $p_x$ ,  $p_y$ , and  $p_z$  be the normal stresses in the direction  $x$ ,  $y$ , and  $z$  respectively. For an element of a cross-sectional thin disc cut at the centre of the cylinder axis there can by symmetry be no shear stress, either of the complementary parts of which (Art. 8) form a couple about the ordinates  $x$ , or  $y$ , or  $z$ . Hence the radial, circumferential, and axial stresses are all principal stresses; each of these principal stresses will be reckoned positive when tensile. We shall assume that the plane sections, originally perpendicular to the axis, remain plane after straining by rotation of the cylinder. From symmetry this cannot be wrong at the central sections, and must in a long cylinder be nearly correct everywhere except near the ends.

An equation of the forces acting radially inward on an element of the cylinder (Fig. 165) will be the same as that for the disc in the previous article, viz.—

$$p_y = \frac{w}{g} \omega^2 x^2 + p_x + x \frac{dp_x}{dx} \dots \dots \dots (1)$$

Also the displacement of a point at a radius  $x$  being to  $x + u$ , as in the disc, the principal strains, from Art. 19, in directions  $x$ ,  $y$ , and  $z$  will be—

radially, 
$$e_x = \frac{du}{dx} = \frac{1}{E} \left( p_x - \frac{p_y + p_z}{m} \right) \dots \dots \dots (2)$$

circumferentially, 
$$e_y = \frac{u}{x} = \frac{1}{E} \left( p_y - \frac{p_x + p_z}{m} \right) \dots \dots \dots (3)$$

axially, 
$$e_z = \frac{1}{E} \left( p_z - \frac{p_x + p_y}{m} \right) \dots \dots \dots (4)$$

and if plane sections remain plane,  $e_z$  is evidently a constant with respect to  $x$ .

From (4) 
$$p_z = \frac{p_x + p_y}{m} + Ee_z \dots \dots \dots (5)$$

Substituting this value in (2) and (3)—

$$p_y = \frac{Em}{(m-2)(m+1)} \left\{ (m-1) \frac{u}{x} + \frac{du}{dx} + e_z \right\} \dots \dots (6)$$

$$p_x = \frac{Em}{(m-2)(m+1)} \left\{ (m-1) \frac{du}{dx} + \frac{u}{x} + e_z \right\} \dots \dots (7)$$

<sup>1</sup> The results here deduced have been obtained by Dr. Chree by the method of strain analysis. See *Proc. Camb. Phil. Soc.*, vol. vii. part vi., 1892, p. 283.

Substituting these values in (1), exactly as in the disc problem of the previous article—

$$x \frac{d^2u}{dx^2} + \frac{du}{dx} - \frac{u}{x} = -\frac{w}{g} \omega^2 \frac{(m+1)(m-2)}{Em(m-1)} x^2 \quad \dots (8)$$

The complete solution practically as before is—

$$\frac{u}{x} = A + \frac{B}{x^2} - \frac{w}{g} \omega^2 \frac{(m+1)(m-2)}{8Em(m-1)} x^2 \quad \dots (9)$$

$$\frac{du}{dx} = A - \frac{B}{x^2} - \frac{3w}{g} \omega^2 \frac{(m+1)(m-2)}{8Em(m-1)} x^2 \quad \dots (10)$$

*Hollow Cylinder.*—The conditions, as in the disc with a central hole, being  $p_x = 0$  for  $x = R_1$  where  $R_1$  is the external radius, and  $p_x = 0$  for  $x = R_2$ , the internal radius, the constants A and B are found by substituting the values of  $\frac{u}{x}$  and  $\frac{du}{dx}$  from (9) and (10) in (7), which gives—

$$B = \frac{w}{g} \frac{\omega^2}{8} \frac{(m+1)(3m-2)}{Em(m-1)} R_1^2 R_2^2 \quad \dots (11)$$

$$A = \frac{w}{g} \cdot \frac{\omega^2}{8} \frac{(m+1)(m-2)(3m-2)}{Em^2(m-1)} (R_1^2 + R_2^2) - \frac{e_z}{m} \quad (12)$$

*To find the Constant  $e_z$ .*—If the cylinder is divided into halves by a plane perpendicular to the axis and midway between the ends, since either half of the cylinder has no motion parallel to the axis, and no external force parallel to the axis acts on the free end, there must be no resultant thrust or pull in an axial direction across the central section or—

$$2\pi \int_{R_2}^{R_1} p_x x dx = 0 \quad \dots (13)$$

From (5), substituting the values of  $p_x$  and  $p_y$  from (6) and (7) with the values (9) and (10)—

$$p_x = \frac{Em}{(m-2)(m+1)} \left\{ 2A - \frac{w}{g} \frac{\omega^2}{2} \frac{(m+1)(m-2)}{Em(m-1)} x^2 + \frac{2e_z}{m} \right\} + Ee_z \quad (14)$$

Substituting for A from (12), and multiplying by  $x$ —

$$p_x x = \frac{w}{g} \frac{\omega^2}{4} \left\{ \frac{3m-2}{m(m-1)} (R_1^2 + R_2^2) x - \frac{2x^3}{m-1} \right\} + Ee_z x \quad (15)$$

Hence, integrating between limits  $R_1$  and  $R_2$ , and inserting the condition (13)—

$$\frac{w}{g} \frac{\omega^2}{4} \left\{ \frac{3m-2}{m(m-1)} \cdot \frac{R_1^4 - R_2^4}{2} - \frac{R_1^4 - R_2^4}{2(m-1)} \right\} + \frac{1}{2} Ee_z (R_1^2 - R_2^2) = 0$$

$$e_z = -\frac{w}{g} \frac{\omega^2}{2} \frac{R_1^2 + R_2^2}{mE} \quad \dots (16)$$

Inserting this value in (12)—

$$\Lambda = \frac{w}{g} \frac{\omega^2}{E} (R_1^2 + R_2^2) \cdot \frac{3m-5}{8(m-1)} \dots \quad (17)$$

The circumferential strain—

$$\frac{u}{x} = \frac{w}{g} \frac{\omega^2}{8E} \left\{ \frac{3m-5}{m-1} (R_1^2 + R_2^2) + \frac{(m+1)(3m-2)}{m(m-1)} \frac{R_1^2 R_2^2}{x^2} - \frac{(m+1)(m-2)}{m(m-1)} x^2 \right\} \quad (18)$$

The radial strain—

$$\frac{du}{dx} = \frac{w}{g} \frac{\omega^2}{8E} \left\{ \frac{3m-5}{m-1} (R_1^2 + R_2^2) - \frac{(m+1)(3m-2)}{m(m-1)} \frac{R_1^2 R_2^2}{x^2} - \frac{3(m+1)(m-2)}{m(m-1)} x^2 \right\} \quad (19)$$

The hoop tension—

$$p_y = \frac{w}{g} \frac{\omega^2}{8} \left\{ \frac{3m-2}{m-1} \left( R_1^2 + R_2^2 + \frac{R_1^2 R_2^2}{x^2} \right) - \frac{m+2}{m-1} x^2 \right\} \quad (20)$$

The radial tension—

$$p_x = \frac{w}{g} \cdot \frac{\omega^2}{8} \cdot \frac{3m-2}{m-1} \left( R_1^2 + R_2^2 - \frac{R_1^2 R_2^2}{x^2} - x^2 \right) \quad (21)$$

The axial stress intensity—

$$p_z = \frac{w}{g} \frac{\omega^2}{4} (R_1^2 + R_2^2 - 2x^2) \frac{1}{m-1} \dots \quad (22)$$

The hoop tension  $p_y$  is evidently always positive, and has its greatest value when  $x = R_2$ , viz.—

$$(\text{max.}) p_y = \frac{w}{g} \frac{\omega^2}{4} \left( \frac{3m-2}{m-1} R_1^2 + \frac{m-2}{m-1} R_2^2 \right) \dots \quad (23)$$

Note that when  $R_2$  is very small this approaches—

$$\frac{w}{g} \cdot \frac{\omega^2}{4} \cdot \frac{3m-2}{m-1} R_1^2 \dots \quad (24)$$

which is the maximum hoop tension for a cylinder with a small central bore; and when  $R_2$  approaches  $R_1$ ,  $p_y$  approaches  $\frac{w}{g} (\omega R_1)^2$ , the same value as in (1), Art. 125.

The radial stress  $p_x$ , which is never negative, is zero for  $x = R_1$  and

$x = R_2$ , evidently reaches a maximum for  $x = \sqrt{R_1 R_2}$ , which makes  $\frac{d\phi_x}{dx}$  vanish, and for this radius—

$$\text{max. } \phi_x = \frac{w}{g} \frac{\omega^2}{8} \frac{3m - 2}{m - 1} (R_1 - R_2)^2 \dots (25)$$

The axial stress  $\phi_x$  is greatest for  $x = R_2$ , and decreases continuously as  $x$  increases; it passes through zero when

$$x = \sqrt{\frac{R_1^2 + R_2^2}{2}}$$

becoming negative for all greater values of  $x$ , the greatest compressive stress which occurs at the external curved surface being—

$$\frac{w}{g} \frac{\omega^2}{8} (R_1^2 - R_2^2)$$

The manner in which the three principal stresses vary is shown in Fig. 166 (see Ex. 1 below). This figure also shows the strain which, according to the "greatest strain" theory, Art. 25, is the measure of elastic strength; the maximum value of  $E \frac{u}{x}$  at the inner curved surface, and all values until near the outer surface, are less than the corresponding values of  $\phi_y$ , the hoop stress. The greatest "stress difference" which, according to the "shear stress" theory, Art. 25, is the measure of elastic strength, is  $\phi_y - \phi_x$  at the inner curved surface, and  $\phi_y - \phi_x$  a short distance outwards from it; its maximum value, however, occurs at the inner surface, where it is equal to  $\phi_y$ . Thus, according to the "greatest strain" theory, the cylinder is strengthened by the axial stress, while the "greatest stress-difference" indicates the same elastic strength as the maximum principal stress.

*Solid Cylinder.*—When the cylinder has no central bore the conditions as in the solid disc, are  $\phi_x = 0$  for  $x = R_1$  and  $u = 0$  for  $x = 0$ ; hence, from equations (9), (10), and (7)—

$$B = 0 \quad A = \frac{w}{g} \frac{\omega^2}{8E} \frac{(m + 1)(m - 2)(3m - 2)}{m^2(m - 1)} \cdot R_1^2 - \frac{e_z}{m} \dots (26)$$

and inserting the condition—

$$2\pi \int_0^{R_1} \phi_x x dx = 0 \dots (27)$$

corresponding to the condition (13), we find—

$$e_z = -\frac{w}{g} \frac{\omega^2}{2} \frac{R_1^2}{mE} \dots (28)$$

and hence, from (26)—

$$A = \frac{w}{g} \frac{\omega^2}{8E} \cdot \frac{3m - 5}{m - 1} \cdot R_1^2 \dots (29)$$

Inserting these values of A and B in (9) and (10), and substituting for  $\frac{u}{x}$  and  $\frac{du}{dx}$  in (6) and (7)—

$$p_y = \frac{w}{g} \cdot \frac{\omega^2}{8} \left( \frac{3m-2}{m-1} R_1^2 - \frac{m+2}{m-1} x^2 \right) \dots (30)$$

$$p_x = \frac{w}{g} \frac{\omega^2}{8} \cdot \frac{3m-2}{m-1} \cdot (R_1^2 - x^2) \dots (31)$$

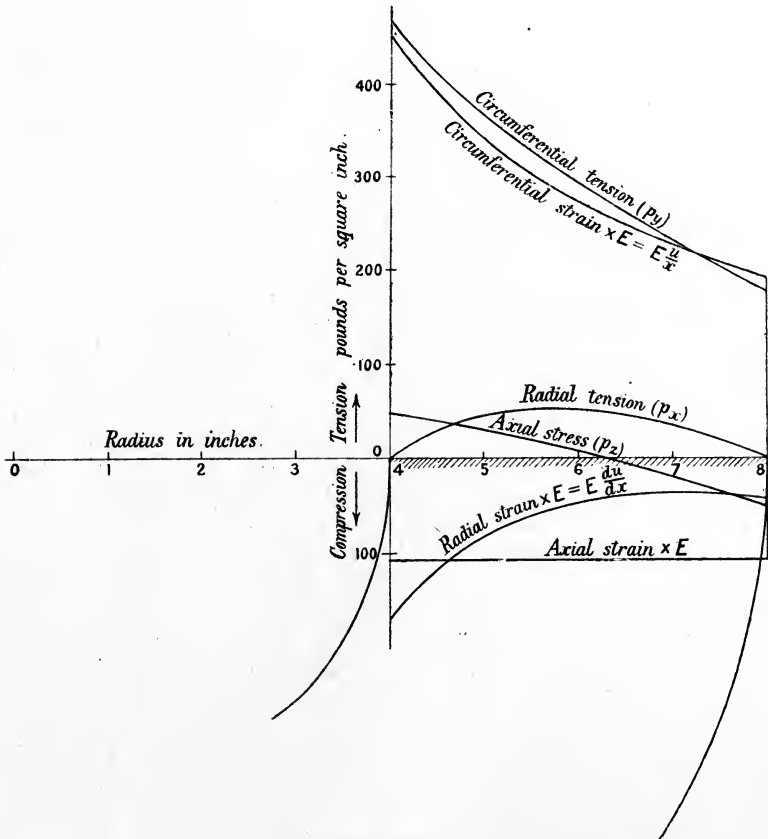

FIG. 166.

and the axial stress—

$$p_z = \frac{w}{g} \frac{\omega^2}{4} (R_1^2 - 2x^2) \frac{1}{m-1} \dots (32)$$

The values (30), (31), and (32) may be obtained from (20), (21), and



(22) by omitting all terms which contain  $R_2$ , and the strains  $\frac{u}{x}$  and  $\frac{du}{dx}$  which may be obtained by putting the above values (26) of A and B in (9) and (10), are equal to the corresponding values (18) and (19) with all terms containing  $R_2$  omitted. In the solid cylinder the hoop tension is greatest at the axis, viz.—

$$(\text{max.}) \phi_y = \frac{w}{g} \cdot \frac{\omega^2}{8} \cdot \frac{3m-2}{m-1} R_1^2 \quad \dots \quad (33)$$

this value being only half that in (24) for a "hollow" cylinder with a very small central bore.

The intensity of radial stress  $\phi_x$  has its greatest value at the axis when it is equal to the hoop tension (33); it is everywhere tensile, falling off continuously to zero at the curved outer surface. The intensity of axial stress  $\phi_z$  varies from a greatest tension—

$$\frac{w}{g} \cdot \frac{\omega^2}{4} \cdot \frac{R_1^2}{m-1}$$

at the axis to a compressive stress of the same magnitude at the outside where  $x = R_1$ , passing through zero at  $x = \frac{R_1}{\sqrt{2}}$ . The variation in stresses and strains in the solid cylinder is shown in Fig. 167 (see Ex. 2 below); the dotted curves illustrate the case of the same cylinder with a small central bore. In the solid cylinder the "greatest stress-difference" is everywhere  $\phi_y - \phi_x$ , and its greatest value occurring at the axis is considerably less than the greatest principal stress, but greater than the simple stress  $\left(E \frac{u}{x}\right)$  equivalent to the maximum principal strain which is reduced by positive values of the radial and axial stresses.

*Comparison of Cylinder and Disc.*—The values of the hoop and radial stresses in the cylinder and disc do not differ very materially, as may be seen by comparing, say, (20) and (21) of the present article with (19) and (18) of Art. 126. The value of  $m$  may be taken to vary for metals from 3 to 4, the former being approached in cast iron and the latter in mild steel; in calculating stresses the lower value of  $m$  errs on the side of safety, *i.e.* of giving a higher calculated intensity of stress. Taking  $m = 3$  for comparison, we have—

For a disc, intensity of hoop stress—

$$\phi_y = \frac{w \omega^2}{g} \left\{ 3 \cdot 3 \left( R_1^2 + R_2^2 + \frac{R_1^2 R_2^2}{x^2} \right) - 2x^2 \right\} \quad \dots \quad (34)$$

intensity of radial stress—

$$\phi_x = \frac{w \omega^2}{g} \cdot \left( R_1^2 + R_2^2 - \frac{R_1^2 R_2^2}{x^2} - x^2 \right) 3 \cdot 3 \quad \dots \quad (35)$$

For a cylinder, intensity of hoop stress—

$$p_y = \frac{w \omega^2}{g} \left\{ 3.5 \left( R_1^2 + R_2^2 + \frac{R_1^2 R_2^2}{x^2} \right) - 2.5 x^2 \right\} \quad (36)$$

intensity of radial stress—

$$p_x = \frac{w \omega^2}{g} \left( R_1^2 + R_2^2 - \frac{R_1^2 R_2^2}{x^2} - x^2 \right) 3.5 \quad (37)$$

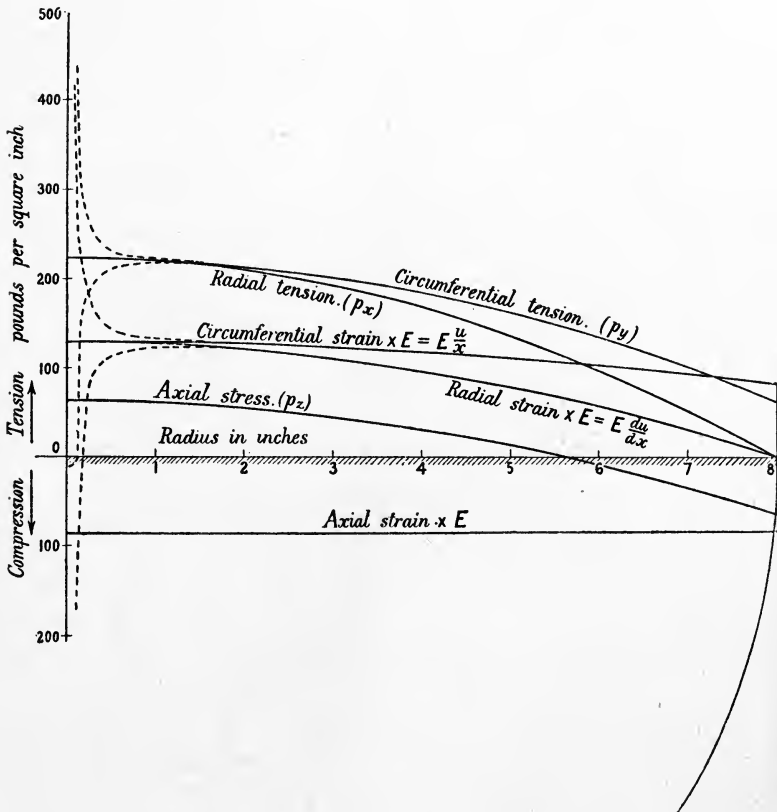

FIG. 167.

Thus, with the supposition of free axial expansion or contraction in the disc or very short cylinder, the stresses are not greatly different from those calculated for the long cylinder on the supposition that plane cross-sections remain plane. The results for a long cylinder may therefore with some confidence be applied as approximately correct to cylinders which are not long.

It is interesting to note that, if we suppose such end forces applied

to the cylinder as to prevent axial strain everywhere (*i.e.* to make  $e_z = 0$ ), the hoop and radial stresses are not affected, and the calculation of their values is considerably simplified.

*Numerical Values for Cylinders.*—Inch units,  $g = 32.2 \times 12$  inches per second per second,  $n$  = number of rotations per minute.

*Cast Iron.*—Taking  $w = 0.26$  lb. per cubic inch,  $m = 3$ , for the hollow cylinder (23) becomes—

$$(\text{max.}) p_y = n^2(6.46R_1^2 + 0.92R_2^2) \times 10^{-6} \text{ pounds per sq. inch} \quad (38)$$

For the solid cylinder (33) becomes—

$$(\text{max.}) p_y = 3.23n^2R_1^2 \times 10^{-6} \text{ pounds per sq. inch} \quad (39)$$

*Mild Steel.*—Taking  $w = 0.28$  lb. per cubic inch,  $m = 4$ , for the hollow cylinder (23) becomes—

$$(\text{max.}) p_y = n^2(6.62R_1^2 + 1.32R_2^2) \times 10^{-6} \text{ pounds per sq. inch} \quad (40)$$

For the solid cylinder (33) becomes—

$$(\text{max.}) p_y = 3.31n^2R_1^2 \times 10^{-6} \text{ pounds per sq. inch} \quad (41)$$

A comparison of (41) with (26) of Art. 126 shows only about 3 per cent. difference in the maximum hoop stress of solid discs and cylinders.

**EXAMPLE 1.**—Find the intensity of hoop stress in a cast-iron cylinder 16 inches external and 8 inches internal diameter, rotating at 1040 revolutions per minute, taking the weight 0.26 lb. per cubic inch and Poisson's ratio  $\frac{1}{3}$ .

From the formula (20), Art. 127,  $R_1$  being 8 inches,  $R_2$  being 4 inches, and  $g$  being  $32.2 \times 12$ —

$$\begin{aligned} p_y &= \frac{0.26}{32.2 \times 12} \times \left( \frac{2\pi \times 1040}{60} \right)^2 \times \frac{1}{8} \left\{ \frac{7}{2} \left( 80 + \frac{1024}{x^2} \right) - \frac{5}{2} x^2 \right\} \\ &= 3.5 \left( 80 + \frac{1024}{x^2} \right) - 2.5x^2 \text{ pounds per square inch} \end{aligned}$$

The various values of  $p_y$  are shown in Fig. 166. The maximum value at  $x = 4$  is—

$$3.5 \times 144 - 40 = 464 \text{ pounds per square inch}$$

which may be checked by the formula (38).

**EXAMPLE 2.**—Find the intensity of hoop stress in a solid cylinder of cast iron 16 inches diameter when making 1040 rotations per minute about its axis.

Taking the constants as in Ex. 1 above, from (30), Art. 127—

$$p_y = \frac{7}{2} \times 64 - \frac{5}{2} x^2 = 224 - 2.5x^2 \text{ pounds per square inch}$$

the maximum value being 224 at  $x = 0$ .

If there is a hole  $\frac{1}{8}$  inch diameter at the centre, putting  $R_2 = \frac{1}{10}$  in. (20)—

$$p_y = \frac{7}{2} \left( 64.01 + \frac{0.64}{x^2} \right) - \frac{5}{2} x^2$$

For  $x = \frac{1}{10}$  inch this gives—

(max.)  $p_y = 3.5 \times 128.01 - 2.5 \times 0.01 = 448.01$  pounds per sq. inch or twice the value 224 for a solid cylinder. The values of  $p_y$  for both cases are shown in Fig. 167.

**128. Rotating Disc of varying Thickness.**—Having found that the radial and hoop stresses in a long cylinder do not very materially differ from those in a very uniform thin disc in which free axial strain is assumed, we may as an approximation find the stress in a disc of small but varying thickness by the method of Art. 126, assuming that the radial and hoop stresses are principal stresses, and that the axial principal stress is zero. Let  $x$ ,  $y$ , and  $z$  be measured radially, tangentially, and axially respectively, as in the previous article,  $z$  being the variable thickness of the disc at a radius  $x$ . Considering, as for the uniform disc and the cylinder, the forces on an element of the disc (Fig. 168) of radial thickness  $\delta x$ , and subtending an angle  $\delta\theta$  at the centre, if it rotates with uniform angular velocity  $\omega$ , the radial inward force, with the same symbols as before, must be—

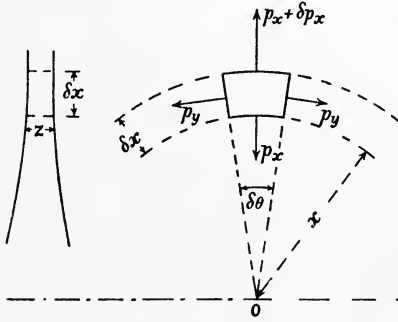

FIG. 168.

$$\frac{w}{g} \omega^2 x \cdot x \delta\theta \cdot \delta x \cdot z \dots \dots \dots (1)$$

and to the same order of smallness the internal radial inward forces are—

$$p_y \cdot z \delta x \cdot \delta\theta + p_x \cdot z \cdot x \delta\theta - (p_x + \delta p_x)(x + \delta x) \delta\theta (z + \delta z)$$

or,  $(p_y \cdot z \cdot \delta x - p_x \cdot z \cdot \delta x - x z \delta p_x - p_x x \delta z) \delta\theta \dots \dots (2)$

Equating (1) and (2)—

$$z \cdot p_y = \frac{w}{g} \omega^2 x^2 z + p_x z + p_x x \frac{dz}{dx} + x z \frac{dp_x}{dx} = \frac{w}{g} \omega^2 x^2 z + \frac{d}{dx} (x z p_x) \quad (3)$$

As in Art. 126, if  $p_z = 0$  and  $u$  is the radial displacement at a radius  $x$ , by Art. 19—

$$\text{hoop strain} = \frac{u}{x} = \frac{1}{E} \left( p_y - \frac{p_x}{m} \right)$$

$$\text{radial strain} = \frac{du}{dx} = \frac{1}{E} \left( p_x - \frac{p_y}{m} \right)$$

and hence, as before—

$$p_y = \frac{Em}{m^2 - 1} \left( m \frac{u}{x} + \frac{du}{dx} \right) \dots \dots \dots (4)$$

$$p_z = \frac{Em}{m^2 - 1} \left( \frac{u}{x} + m \frac{du}{dx} \right) \dots \dots \dots (5)$$

Substituting these values in (3) and reducing—

$$\frac{d^2u}{dx^2} + \left( \frac{1}{z} \frac{dz}{dx} + \frac{1}{x} \right) \frac{du}{dx} + \left( \frac{1}{mxz} \frac{dz}{dx} - \frac{1}{x^2} \right) u = -\frac{w}{g} \omega^2 \frac{m^2 - 1}{m^2} x \quad (6)$$

The integration of this equation depends upon the form of  $z$ ; for example, if  $z = kx^n$  (6) becomes—

$$\frac{d^2u}{dx^2} + \frac{n + 1}{x} \frac{du}{dx} + \frac{n - m}{mx^2} \cdot u = -\frac{w}{g} \omega^2 \frac{m^2 - 1}{m^2 E} x \quad (7)$$

or, 
$$x^2 \frac{d^2u}{dx^2} + (n + 1)x \frac{du}{dx} + \frac{n - m}{m} \cdot u = -\frac{w}{g} \omega^2 \frac{m^2 - 1}{m^2} x^3 \quad (8)$$

a homogeneous linear equation. The complementary function may be obtained by assuming  $u = cx^a$ . Substituting the value for  $u$ ,  $\frac{du}{dx}$  and  $\frac{d^2u}{dx^2}$  on the left side of the equation  $a$  must satisfy the condition—

$$a^2 + na + \frac{n}{m} - 1 = 0$$

$a$  being either of the roots  $a_1$  or  $a_2$  of this quadratic and the complementary function being—

$$u = C_1 x^{a_1} + C_2 x^{a_2} \dots \dots \dots (9)$$

A particular integral of (8) may be found by assuming  $u = Bx^3$ . Substituting this in (8) we find—

$$B = -\frac{w}{g} \cdot \frac{\omega^2}{E} \cdot \frac{m^2 - 1}{m(3mn + 8m + n)} \dots \dots (10)$$

and the complete solution is—

$$u = C_1 x^{a_1} + C_2 x^{a_2} - \frac{w \omega^2}{g E} \frac{m^2 - 1}{m(3mn + 8m + n)} x^3 \dots \dots (11)$$

Inserting the value of  $\frac{u}{x}$  and  $\frac{du}{dx}$  in (4) and (5), the constants  $C_1$  and  $C_2$  are to be found from some known condition. When the disc forms part of a wheel the known conditions of stress or of the strain  $\frac{u}{x}$  arise at the rim and at the hub or nave; for example, at the junction of the disc and rim the hoop strains in the two parts must be equal, and the mean radial-stress intensities in the rim and disc near their junction must be inversely proportional to their thickness; probably the intensities vary

across the thickness, this variation being greater when the change in thickness is abrupt.

*Disc of Uniform Strength.*—An interesting case arises if the radial and hoop-stress intensities are to be everywhere equal to one another and of constant magnitude, *i.e.*  $p_x = p_y = f = \text{constant}$ . Substituting this value in (3)—

$$f \cdot z = \frac{w}{g} \omega^2 \cdot z \cdot x^2 + f \frac{d}{dx}(xz)$$

$$\text{or, } \frac{dz}{dx} + \frac{w}{g} \cdot \frac{\omega^2}{f} \cdot z \cdot x = 0$$

Multiplying by the integrating factor  $e^{\frac{w \omega^2}{2f} x^2}$  —

$$\frac{d}{dx} \left( z e^{\frac{w \omega^2}{2f} x^2} \right) = 0$$

$$\text{and integrating, } z = A e^{-\frac{w \omega^2}{2f} x^2}$$

where A is a constant; and for  $x = 0$ ,  $z = A$ , the constant being the thickness of the disc at the axis if it extends so far.

#### EXAMPLES XI.

1. What is the necessary thickness of a seamless pipe 4 inches diameter in order that when containing a fluid under a pressure of 200 lbs. per square inch the greatest intensity of stress should not exceed 12,000 lbs. per square inch?

2. What working pressure may be allowed in a cylindrical boiler 6 feet internal diameter with plates  $\frac{5}{8}$  inch thick, if the working tension in the solid plates is not to exceed 10,000 lbs. per square inch?

3. Find the intensity of stress in a cast-iron pipe 10 inches internal diameter and  $\frac{1}{4}$  inch thick under an internal pressure of 50 lbs. per square inch. If the pipe had been closely wound with a single layer of steel wire  $\frac{1}{8}$  inch diameter under a tensile stress of 1000 lbs. per square inch, what internal pressure would it stand with the same intensity of stress in the pipe? What would be the intensity of tension in the wire under this pressure? Take the modulus of direct elasticity for steel as twice that for cast iron, and take Poisson's ratio as 0.3.

4. Find the necessary thickness of a 5-inch hydraulic main to contain a pressure of 1000 lbs. per square inch, if the stress in the material is limited to 1500 lbs. per square inch. What is the intensity of stress at the outer surface of the pipe?

5. A hydraulic main is 4 inches diameter and is 1 inch thick. What is the allowable internal pressure, if the stress in the material is not to exceed 4000 lbs. per square inch?

6. Find the thickness of metal necessary in a hydraulic cylinder 12 inches diameter to stand a pressure of 1200 lbs. per square inch, if the greatest tension in the material is not to exceed 4000 lbs. per square inch.

7. What must be the thickness of metal in a spherical shell 20 inches diameter, containing a pressure of 200 lbs. per square inch, if the greatest intensity of stress is not to exceed 500 lbs. per square inch?

8. A compound cylinder is formed by shrinking a tube 6 inches external and  $4\frac{1}{2}$  inches internal diameter on to another tube, which has an internal diameter of 3 inches. If, after shrinking, the radial compression at the common surface is 4000 lbs. per square inch, find the circumferential stress at the inner and outer surfaces and at the common surface.

9. Find the necessary difference in diameter to be allowed for shrinkage in the previous problem to produce the necessary radial pressure. ( $E = 30 \times 10^6$  lbs. per square inch.)

10. If the compound cylinder in problem No. 8 is subjected to an internal pressure of 10,000 lbs. per square inch, find the intensity of hoop tension at the outer and inner surfaces and the maximum hoop tension.

11. The thin rim of a wheel 3 feet diameter is made of steel, weighing 0.28 lb. per cubic inch. Neglecting the effect of the spokes, how many revolutions per minute may it make without the stress exceeding 10 tons per square inch, and how much is the diameter of the wheel increased? ( $E = 30 \times 10^6$  lbs. per square inch.)

12. Compare the periphery velocities for the same maximum intensity of stress of (1) a solid cylinder, (2) a solid thin disc, (3) a thin ring. Take the velocity of the ring as unity and  $m = 3.5$ .

13. The cast-iron cylindrical case of a friction clutch is 19 inches internal diameter and  $\frac{7}{8}$  inch thick. The internal radial pressure of the friction blocks on the case is 80 lbs. per square inch, and the case makes about its axis 500 revolutions per minute. Estimate the greatest intensity of tensile stress in the material of the case, which may be taken as a thin shell. Weight of cast iron 0.26 lb. per cubic inch.

## CHAPTER XII.

### *BENDING OF CURVED BARS.*

129. **Theory of Bending.**—The relations between the straining actions and the stresses and strains produced in the “simple bending” of a straight beam under certain fundamental assumptions were established in Arts. 60–64. These relations may also be applied with sufficient exactness to cases where the curvature of the beam is small, *i.e.* where the radius of curvature of the central longitudinal axis is large in comparison with the dimensions of cross-section of the beam. If  $R$  is the initial and  $\rho$  is the final radius of curvature of the longitudinal central axis, we should then have from (1), Art. 61, with the same notation—

$$p = E y \left( \frac{1}{\rho} - \frac{1}{R} \right)$$

and from (4), Art. 63—

$$M = EI \left( \frac{1}{\rho} - \frac{1}{R} \right)$$

or together,

$$\frac{p}{y} = \frac{M}{I} = E \left( \frac{1}{\rho} - \frac{1}{R} \right)$$

According to this approximation, which has been used in Art. 117, the intensity of stress varies as the distance from the central axis of a cross-section perpendicular to the plane of bending. If, when the bar is not originally straight, we make the same fundamental assumptions as in Arts. 60–62 we arrive at a different result, the difference being of considerable magnitude when the curvature is great, as it is in many cases where strength calculations are of importance.

In applying a modified form of the simple or Bernoulli-Euler theory of bending to bars of great curvature, such as hooks, links, and rings, it is to be borne in mind that generally the dimensions of cross-section are not very small in comparison with either the radius of curvature or with the length of the bar: we are thus pushing this theory beyond the limits assumed in the case of straight bars, and the results must be taken as perhaps the best working approximation for the calculation of strength rather than as rigorously correct. It will be assumed that the central line passing through the centroids of radial sections lies wholly in one plane before and after bending. Let  $R$  be the original and  $\rho$



be the final radius of curvature of the central axis of a bar acted on by equal opposite couples  $M$  at its ends (Fig. 169). Let distances of points on the radial cross-sections measured from an axis  $ZZ$ , through the centroid and perpendicular to the radius of curvature, be denoted by  $y$ , and be reckoned positive when measured outwards from the centre of curvature, and negative inwards towards it; let breadths of the section perpendicular to  $y$  be  $z$ , and let  $A$  be the constant area of section  $\Sigma(zdy)$  or  $\Sigma(\delta a)$ , where  $\delta a$  is an element of area.

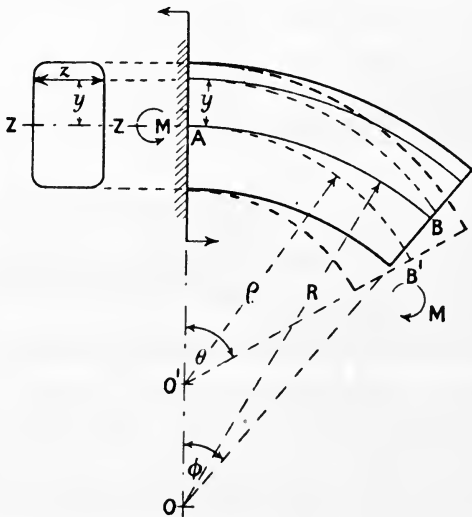

FIG. 169.

Consider a short length, the central axis ( $AB$ ) of which originally subtends an angle  $\phi$  at its centre of curvature  $O$ , and after bending subtends an angle  $\theta$  at its new centre of curvature  $O'$ . The original length of the layer distant  $y$  from the central axis is—

$$(R + y)\phi$$

and the final length is—

$$(\rho + y')\theta$$

where  $y'$  is the value of  $y$  after strain. Hence the circumferential strain of this layer is—

$$e = \frac{(\rho + y')\theta}{(R + y)\phi} - 1 \dots \dots \dots (1)$$

Also the central line has the final length—

$$\rho\theta = R\phi(1 + e_0) \dots \dots \dots (2)$$

where  $e_0$  is the circumferential strain at the central line  $y = 0$ , hence—

$$\frac{\theta}{\phi} = (1 + e_0)\frac{R}{\rho}$$

and substituting this value in (1)—

$$e = \frac{\rho + y'}{R + y} \times \frac{R}{\rho}(1 + e_0) - 1 = \frac{1 + \frac{y'}{\rho}}{1 + \frac{y}{R}}(1 + e_0) - 1 \dots (3)$$

The subsequent work will be greatly simplified if we neglect the difference between  $y'$  and  $y$ , and write approximately—

$$e = \frac{1 + \frac{y}{\rho}}{1 + \frac{y}{R}}(1 + e_0) - 1 = \frac{y(1 + e_0)\left(\frac{1}{\rho} - \frac{1}{R}\right)}{1 + \frac{y}{R}} + e_0 \quad (4)$$

And assuming the circumferential strain to be free as in simple and uniform direct stress, at the layer distant  $y$  from the central line the intensity of stress—

$$p = E \cdot e \quad (5)$$

Also, as in Art. 62—

$$\Sigma(p\delta a) = 0 = E\Sigma(e \cdot \delta a) \quad (6)$$

dividing by  $E$  and substituting the value of the variable  $e$  from (4)—

$$(1 + e_0)\left(\frac{1}{\rho} - \frac{1}{R}\right)\Sigma\left(\frac{y}{1 + \frac{y}{R}} \cdot \delta a\right) + e_0A = 0 \quad (7)$$

or, 
$$R(1 + e_0)\left(\frac{1}{\rho} - \frac{1}{R}\right)\Sigma\left(\frac{y}{y + R} \cdot \delta a\right) + e_0A = 0 \quad (8)$$

Again, as in Art. 63, equating the bending moment to the moment of resistance, using the values of  $p$  from (5) and (4) as before—

$$M = \Sigma(y \cdot p \cdot \delta a) = E \left\{ e_0 \Sigma(y \delta a) + (1 + e_0) \left( \frac{1}{\rho} - \frac{1}{R} \right) \Sigma \left( \frac{y^2 \delta a}{1 + \frac{y}{R}} \right) \right\}$$

or, since  $\Sigma(y \delta a) = 0$ ,  $y$  being measured from an axis through the centroid—

$$\frac{M}{E} = R(1 + e_0)\left(\frac{1}{\rho} - \frac{1}{R}\right)\Sigma\left(\frac{y^2 \delta a}{y + R}\right) \quad (9)$$

From (8) and (9) the unknown quantities  $e_0$  and  $\rho$  may be found, and then from (4) and (5)  $p$  may be found for any value of  $y$ . The values of  $e_0$  and  $\rho$  will involve the above quantities  $\Sigma\left(\frac{y}{y + R} \cdot \delta a\right)$  and  $\Sigma\left(\frac{y^2}{y + R} \delta a\right)$ , which can be found by ordinary integration or graphically. We may, however, conveniently reduce these summations before solving (8) and (9) for  $e_0$  and  $\rho$ , as follows:—

$$\Sigma\left(\frac{y}{y + R} \cdot \delta a\right) = \Sigma\left\{\left(1 - \frac{R}{y + R}\right)\delta a\right\} = \Sigma(\delta a) - R\Sigma\left(\frac{\delta a}{y + R}\right) = A - A' \quad (10)$$

where<sup>1</sup>  $A' = \Sigma\left(\frac{R}{y+R} \cdot \delta a\right)$  or  $R\Sigma\left(\frac{\delta a}{y+R}\right) \dots \dots \dots (11)$

$$\Sigma\left(\frac{y^2}{y+R} \cdot \delta a\right) = \Sigma\left\{\left(y - R + \frac{R^2}{y+R}\right)\delta a\right\} = \Sigma(y\delta a) - R\Sigma(\delta a) + R^2\Sigma\left(\frac{\delta a}{y+R}\right)$$

$$= 0 - RA + RA'$$

or—

$$\Sigma\left(\frac{y^2}{y+R} \delta a\right) = R(A' - A) \quad \text{or} \quad -R\Sigma\left(\frac{y}{y+R} \delta a\right) \dots \dots \dots (12)$$

Substituting the values (11) and (12) in equations (8) and (9) respectively—

$$R(1 + e_0)\left(\frac{1}{\rho} - \frac{1}{R}\right)(A' - A) = e_0 \cdot A \dots \dots \dots (13)$$

$$R^2(1 + e_0)\left(\frac{1}{\rho} - \frac{1}{R}\right)(A' - A) = \frac{M}{E} \dots \dots \dots (14)$$

hence  $e_0 = \frac{M}{EAR} \quad \frac{1}{\rho} - \frac{1}{R} = \frac{M}{EAR + M} \times \frac{A}{(A' - A)R} \dots \dots \dots (15)$

hence, substituting these values in (4) and (5)—

$$p = \frac{M}{R} \left\{ \frac{y}{(y+R)(A' - A)} + \frac{1}{A} \right\} \dots \dots \dots (16)$$

or,  $p = \frac{M}{(y+R)A} \left( 1 + \frac{y}{R} \cdot \frac{A'}{A' - A} \right) \dots \dots \dots (16a)$

or,  $p = \frac{M}{R(A' - A)} \left( \frac{A'}{A} - \frac{R}{y+R} \right) \dots \dots \dots (16b)$

From (16a)  $p$  is evidently zero when—

$$y = -R \frac{A' - A}{A} = h \text{ (say)} \dots \dots \dots (17)$$

which gives the position of the neutral surface, the negative sign denoting that it is on the “inner” side of the central line. From (16b) the intensity of stress on the outside of the central line evidently reaches a maximum value when  $y$  reaches its greatest positive value,

<sup>1</sup> The quantity  $A'$  is commonly expressed in terms of  $R\Sigma\left(\frac{y^2\delta a}{y+R}\right)$ , a modified moment of inertia of section. It appears to the author more convenient to express  $R\Sigma\left(\frac{y^2\delta a}{y+R}\right)$  in terms of  $A'$ , the modified area and other known constants. Another alternative would be to use a special symbol for  $-\Sigma\left(\frac{y}{y+R} \cdot \delta a\right)$  or  $A' - A$ .

and the stress on the inside reaches its maximum value when  $y$  reaches its greatest negative value. According to the above formulæ and convention as to the sign of  $y$ , the stress on the convex side of the section will be positive, and that on the concave side will be negative if  $M$  is taken as a positive quantity.

*Alternative Form of Result.*—Making as before the approximation  $y' = y$  in (1)—

$$e = \frac{(\rho + y)\theta}{(R + y)\phi} - 1 = \frac{\theta(\rho + y) - \phi(R + y)}{\phi(R + y)} = \frac{y(\theta - \phi) + \theta\rho - \phi R}{\phi(R + y)} \quad (18)$$

which is zero when  $y = -\frac{\rho\theta - R\phi}{\theta - \phi} = h$  (say) . . . . . (19)

where  $h$  is the distance of the neutral axis from the centroid of the section. Substituting in (18)—

$$e = \frac{y - h}{R + y} \times \frac{\theta - \phi}{\phi} = \frac{y - h}{R + y} \times C \quad . . . \quad (20)$$

where  $C$  is a constant. And since  $E\Sigma(e\delta a) = 0$ —

$$\begin{aligned} \Sigma\left(\frac{y - h}{R + y} \delta a\right) &= 0 = \Sigma\left(\frac{y}{R + y} \delta a\right) - h\Sigma\left(\frac{\delta a}{R + y}\right) \\ h &= \frac{\Sigma\left(\frac{y}{R + y} \delta a\right)}{\Sigma\left(\frac{\delta a}{R + y}\right)} = -\frac{R(A' - A)}{A'} \quad (\text{as before}) \end{aligned}$$

Also since—

$$M = \Sigma(p \cdot y \cdot \delta a) = E\Sigma(ey\delta a) = C \times E\Sigma\left\{\frac{y(y - h)}{R + y} \delta a\right\}$$

$$C = \frac{M}{E\Sigma\left\{\frac{y(y - h)}{R + y} \delta a\right\}}$$

Substituting this in (20) and multiplying by  $E$ —

$$p = Ee = \frac{y - h}{y + R} \cdot \frac{M}{\Sigma\left\{\frac{y(y - h)}{R + y} \delta a\right\}} \quad . . . \quad (21)$$

and  $\Sigma\left\{\frac{y(y - h)}{R + y} \delta a\right\} = \Sigma\left\{\left(y - h - R\frac{y - h}{y + R}\right)\delta a\right\} = 0 - hA - 0$

hence  $p = \frac{M}{-hA} \cdot \frac{y - h}{y + R} \quad . . . \quad (22)$

This form is very simple in appearance, but in order to use it  $h$  must be

evaluated: substituting for  $h$  its value (17), the form (22) reduces to the values in (16), (16a), or (16b). The evaluation of the quantity  $A'$  (and consequently of  $h$ ) for common forms of section is dealt with in the two following articles. Equation (16b) shows that if  $y$  and  $p$  are plotted as rectangular co-ordinates, the result is a rectangular hyperbola (see Fig. 171).

As in the case of bending of straight bars, these formulæ strictly referring to "simple" bending may be applied as approximations to cases where the bending action is not simple, but when in addition to a bending couple there is a shearing force in the planes of the cross-sections as in Arts. 133 and 136 below.

130. **Various Sections.**—In order to use the formulæ of the previous article it is necessary to find the quantity—

$$A' = \Sigma \left( \frac{R}{y + R} \delta a \right) \text{ or } R \Sigma \left( \frac{1}{y + R} \cdot \delta a \right)$$

This is a modified value of  $A$ , the area of section which can easily be found graphically as in the next article, but which can easily be calculated for simple sections.

*Rectangle*, Fig. 170.—Depth  $d$  radially, breadth  $b$  perpendicular to the depth. Taking strips  $b \cdot \delta y = \delta a$ —

$$A' = Rb \int_{-\frac{d}{2}}^{\frac{d}{2}} \frac{dy}{R + y} = Rb \log_e \frac{2R + d}{2R - d} \quad (1)$$

and consequently from (17),  $A$  being equal to  $bd$ —

$$h = - \frac{R \log_e \frac{2R + d}{2R - d} - d}{\log_e \frac{2R + d}{2R - d}} \quad (2)$$

If (1) be expanded—

$$A' = bd \left\{ 1 + \frac{1}{12} \left( \frac{d}{R} \right)^2 + \frac{1}{80} \left( \frac{d}{R} \right)^4 + \dots + \text{etc.} \right\}$$

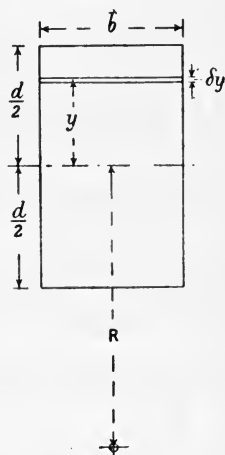

FIG. 170.

The value (1) substituted in (16), Art. 129, or the value (2) substituted in (22), Art. 129, gives the intensity of bending stress in a bar of rectangular section. The variation of this stress for a section curved to a mean radius  $R = d$  is shown in Fig. 171; the curve of variation is a rectangular hyperbola. The straight dotted line indicates the stress intensity resulting from the same bending moment on a straight bar of the same cross-section.

*Circle*, Fig. 172.—

$$\text{Radius } r, \quad y = r \sin \theta \quad z = 2r \cos \theta \quad dy = r \cos \theta d\theta$$

$$A' = R \int_{-r}^r \frac{z dy}{y + R} = 2r^2 R \int_{-\frac{\pi}{2}}^{\frac{\pi}{2}} \frac{\cos^2 \theta \cdot d\theta}{r \sin \theta + R}$$

$$= 2r^2 R \int_{-\frac{\pi}{2}}^{\frac{\pi}{2}} \left( -\frac{1}{r} \sin \theta + \frac{R}{r^2} + \frac{1}{r^2} \cdot \frac{r^2 - R^2}{r \sin \theta + R} \right) d\theta$$

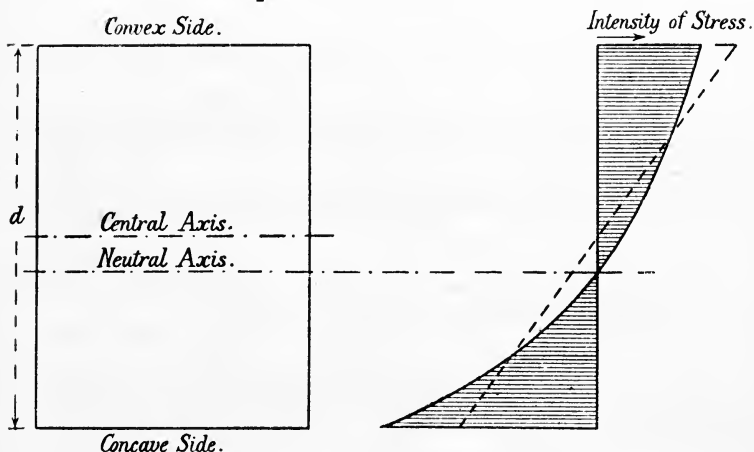

FIG. 171.

$$A' = 0 + 2\pi R^2 - 2\pi R \sqrt{R^2 - r^2} = 2\pi R(R - \sqrt{R^2 - r^2}) \quad \dots (3)$$

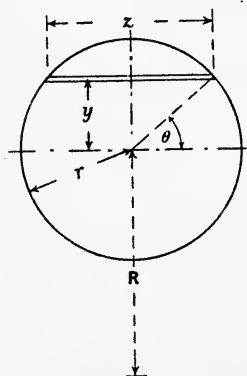

FIG. 172.

Any section—

$$A' = \sum \left( \frac{R}{R + y} \delta a \right)$$

$$= \sum \left\{ \left( 1 - \frac{y}{R} + \frac{y^2}{R^2} - \frac{y^3}{R^3} + \frac{y^4}{R^4} - \dots \right) \delta a \right\}$$

and for symmetrical sections the alternate terms give a zero sum, and

$$A' = A + \frac{I}{R^2} + \frac{1}{R^4} \sum (y^4 \delta a) + \dots (4)$$

where I is the moment of inertia of the section about the axis from which y is measured, the second term of such a series giving a first approximation to the value of A' - A.

**131. Graphical Method of finding Modified Area A'.**—The value of the quantity A' or  $R \sum \left( \frac{\delta a}{y + R} \right)$  for any section may be found

graphically as follows: The centroid  $G$  of the section  $AECFBHDK$ , Fig. 173, may be found as in Art. 68, and then  $OG$  is set off equal to the radius of curvature  $R$ , or, say,  $OD$ , equal to the radius of curvature of the curved surface at  $D$ . Then  $A'$  is the area of a modified figure  $AE'CF'BH'DK'$ , the width of which, perpendicular to  $OG$ , is everywhere modified in the ratio  $\frac{R}{y+R}$ , where  $y$  is the distance from the axis  $AB$  through  $G$  and perpendicular to  $OG$ , by the process shown in the figure. For example, the width  $EF$  is reduced to  $E'F'$  by joining  $F$  to  $O$ , cutting  $AB$  in  $N$ ; a line  $NF'$  perpendicular to  $AB$  from  $N$  cuts  $EF$  in  $F'$ . All widths more remote than  $AB$  from  $O$  are decreased, and the remainder are increased. To use the formulæ of Art. 129, the original area  $A$  and the modified area  $A'$  should be measured accurately by a planimeter.

An alternative construction would be to join  $F$  to the foot of a perpendicular from  $E$  on to a line through  $O$  and parallel to  $AB$ , and thus alter only half the boundary line of the original figure. In symmetrical figures this does not offer any advantage, for only half the figure, viz.  $CF'BH'DGC$ , need in any case be drawn.

**132. Stresses in Hooks.**—We may apply the formulæ of Art. 129 as a very good approximation to find the bending stresses in the principal or horizontal section through the centre of curvature of a hook carrying a vertical load.<sup>1</sup>

Let Fig. 174 represent a hook, the centre of curvature for  $A$  and  $B$  being at  $O$ , so that  $OC = R$ ,  $C$  being the centroid of the section  $AB$ , and the vertical load line of the weight  $W$  passing through  $D$ , so that  $CD = l$ . Then, if  $A$  is the area  $AEBF$  of the section at  $AB$ , and  $A'$  the area derived from it, as above in Art. 130 or 131, and  $BC = y_i$  and  $AC = y_o$ , allowing for the average tension  $\frac{W}{A}$  in addition to the bending

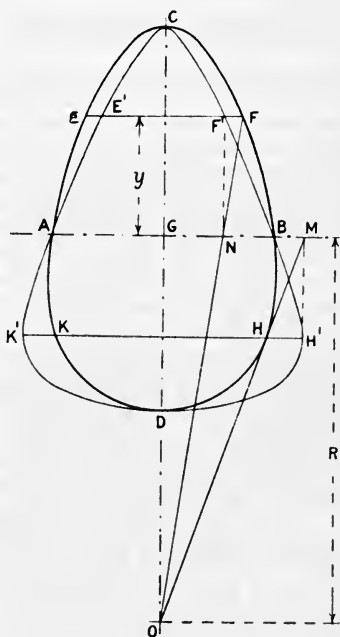

FIG. 173.

<sup>1</sup> For a theory taking account of the lateral strains or change in  $y$  as in (3), Art. 129, see a paper by E. S. Andrews and Karl Pearson, "Drapers Co. Research Memoirs," Technical Series I., published by Dulau & Co.; also an experimental investigation by Prof. Goodman in *Proc. Inst. C.E.*, vol. clxvii.

stresses, and remembering that values of  $y$  towards  $O$  are negative, the extreme intensities of stress, by (i6b), Art. 129, are—

$$\text{intensity of tension at B} = \frac{Wl}{R(A' - A)} \left( \frac{R}{R - y_t} - \frac{A'}{A} \right) + \frac{W}{A} \quad (1)$$

$$\text{intensity of compression at A} = \frac{Wl}{R(A' - A)} \left( \frac{A'}{A} - \frac{R}{R + y_c} \right) - \frac{W}{A} \quad (2)$$

In well-designed steel hooks these two values are generally not very unequal.

**EXAMPLE 1.**—The central horizontal section of a hook is a symmetrical trapezium  $2\frac{1}{4}$  inches deep, the inner width being 2 inches, and the outer width being 1 inch. Estimate the extreme intensities of stress when the hook carries a load of 1.25 tons, the load line passing 2 inches from the inside edge of the section, and the centre of curvature being in the load line.

The section is shown in Fig. 175. The distance  $CB$  of the centroid  $C$  from the inner edge is found by taking moments of the area about  $DE$ . The area is  $\frac{3}{2} \times \frac{9}{4} = 3.375$  square inches.

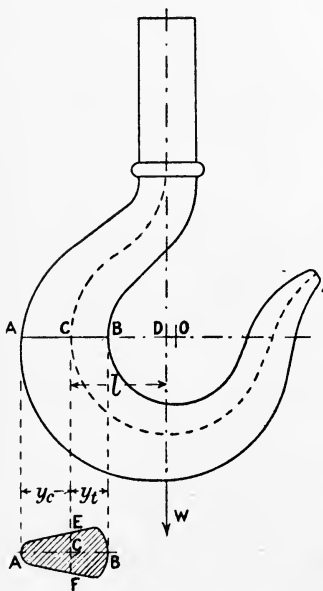

FIG. 174.

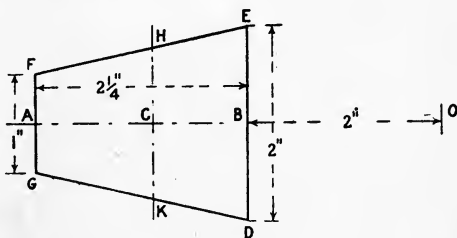

FIG. 175.

$$BC \times (3.375) = (2\frac{1}{4} \times \frac{1}{2} \times 2\frac{1}{4}) + (\frac{1}{2} \times 2\frac{1}{4} \times \frac{1}{3} \times 2\frac{1}{4})$$

$$BC = 1 \text{ inch}$$

Hence the radius of curvature  $R$  at  $C$  is  $OC = 3$  inches.

The width of section  $HK$  is  $2 - \frac{4}{9} = 1\frac{5}{9}$  inch, and measuring  $y$  from  $HK$  positive towards  $A$ , the variable width of section is—

$$z = 1\frac{5}{9} - \frac{4}{9}y = \frac{4}{9}(\frac{7}{2} - y)$$

hence—

$$A' = 3 \times \frac{4}{9} \int_{-1}^{\frac{5}{4}} \frac{3.5 - y}{y + 3} dy = \frac{4}{3} \int_{-1}^{\frac{5}{4}} \left( -1 + \frac{6.5}{y + 3} \right) dy$$

$$= \frac{4}{3} \left( -2.25 + 6.5 \log_e \frac{4.25}{2} \right)$$



$$A' = \frac{4}{3}(-2.25 + 6.5 \times 2.303 \times 0.3273) = 3.5381 \text{ square inches}$$

$$A' - A = 3.5381 - 3.375 = 0.1631 \text{ square inch}$$

Hence, from Art. 132 (1), the maximum tension at B is—

$$\frac{1.25 \times 3}{3 \times 0.1631} \left( \frac{3}{2} - \frac{3.5381}{3.375} \right) + \frac{1.25}{3.375} = \frac{1.25}{0.1631} \times 0.5417 + 0.37$$

$$= 3.83 \text{ tons per square inch}$$

and the maximum compressive stress at A is, by Art. 132 (2)—

$$\frac{1.25 \times 3}{3 \times 0.1631} \left( \frac{3.5381}{3.375} - \frac{3}{4.25} \right) - 0.37 = 2.62 - 0.37 = 2.25 \text{ tons per sq. in.}$$

**133. Stresses in Rings.**—A ring subjected to pull or thrust through its centre has, at any radial section, a bending moment, shearing force, and direct pull or thrust. The intensity of shearing stress on normal planes being zero at the extreme inner and outer edges of a section, in calculating the stresses at the extreme inside and outside of the ring we may neglect the shearing force at the section, and calculate from the bending moment and direct pull or thrust.

*Approximate Variation of Bending Moment.*—If in estimating the bending moment at any section we neglect the curvature of the ring, and use the rules applicable to straight beams, we shall not make nearly so large an error as in neglecting curvature in calculating the stress. A more rigorous examination of the variation in bending moment follows at the end of this article.

If Fig. 176 represents the ring subjected to a pull  $W$ , although there is bending at various sections, it is evident from the symmetry that the four sections at A, F, D, and G pass through the centre O after the straining, and therefore, between A and F, for example, the bending or change from original direction is zero, i.e. the total amounts of bending in opposite senses or of opposite sign are equal.

Let  $M$  be the bending moment producing greater curvature at any section  $XX$  inclined  $\theta$  to the line of pull, and  $M_1$  be the bending moment on the section  $EF$ . The piece  $XEFX$  being in equilibrium and the shearing force on  $EF$  being zero, taking moments about the centre of the section  $XX$ —

$$M = M_1 + \frac{W}{2}R(1 - \sin \theta) \quad \dots \dots \dots (1)$$

And since the total bending between A and F is zero, treating the

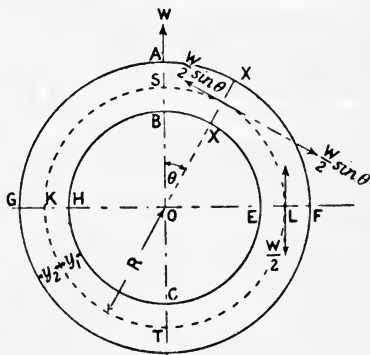

FIG. 176.

ring as a straight beam, as in Art. 77, where  $ds$  is an element of length equal to  $Rd\theta$ , since  $\frac{di}{ds} = \frac{M}{EI}$  the bending per unit length,—

$$\int_0^{\theta=\frac{\pi}{2}} di = \int_0^{\theta=\frac{\pi}{2}} \frac{M}{EI} ds = \frac{R}{EI} \int_0^{\frac{\pi}{2}} M d\theta = 0$$

Substituting the value of  $M$  from (1) and dividing by  $\frac{R}{EI}$ —

$$\int_0^{\frac{\pi}{2}} \left\{ M_1 + \frac{WR}{2} (1 - \sin \theta) \right\} d\theta = M_1 \cdot \frac{\pi}{2} + \frac{WR\pi}{4} - \frac{WR}{2} = 0$$

$$M_1 = \frac{WR}{\pi} \left( 1 - \frac{\pi}{2} \right) \dots \dots (2)$$

and therefore from (1)—

$$M = WR \left( \frac{1}{\pi} - \frac{1}{2} \sin \theta \right) \dots \dots (3)$$

and at the section AB where  $\theta = 0$ —

$$M_0 = \frac{WR}{\pi} \text{ or } 0.318WR \dots \dots (4)$$

The bending moment vanishes for  $\sin \theta = \frac{2}{\pi}$ , and its values at all sections are shown in Fig. 177 plotted radially from the central line SLTK.

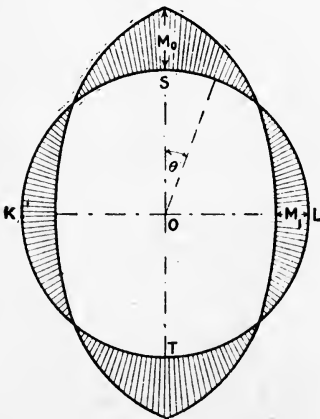

FIG. 177.

*Additional Direct and Shearing Forces.*

—In addition to the bending stress there is on every section such as XX the direct force  $\frac{W}{2} \sin \theta$ , giving an additional circumferential stress of intensity—

$$\frac{W \sin \theta}{2A}$$

and a shearing force  $\frac{W}{2} \cos \theta$  across the radial sections, which will produce shearing stress distributed more or less as indicated in Art. 71. The greatest shearing force  $\frac{W}{2}$  at  $\theta = 0$  will produce

an average shear stress of intensity  $\frac{W}{2A}$ . Taking the circular section, for example, the maximum intensity would be about  $\frac{2}{3}$  of this amount,

viz. at the centre lines of the section AB. The two equal and opposite principal stresses corresponding to this state of simple shear are, even in the smallest rings, of much lower magnitude than the greatest bending stresses. Even the stresses at the centre line arising from shearing force and direct pull are not at any section so great in comparison with the bending stresses at the section AB as to be of much importance. (See end of Ex. 1 below.)

*Resultant Stress at Inside and Outside.*—The most important stresses are those arising from bending and direct stress at the inner and outer edges of the ring at the sections where the bending moments and the direct stress reach their extreme values.

Let  $y_1$  be the distance from the central line to the extreme inside edge of the cross-section, and let  $y_2$  be the distance from the central line to the extreme outside edge of the cross-section; and consider a pull  $W$  as shown in Fig. 176, the modifications for a thrust  $W$  being obvious.

At the *intrados* or inside edge of the ring, putting the value (3) in (16*b*) of Art. 129 ( $y$  being equal to  $-y_1$ ), and adding the direct stress—

$$\text{intensity of compressive stress } p \left. \vphantom{\int} \right\} = \frac{W \left( \frac{1}{\pi} - \frac{1}{2} \sin \theta \right)}{A' - A} \left( \frac{R}{R - y_1} - \frac{A'}{A} \right) - \frac{W \sin \theta}{2A} \quad (5)$$

This reaches critical values at  $\theta = \frac{\pi}{2}$  and at  $\theta = 0$  (a discontinuity).

$$\text{At } \theta = 0, \quad p = \frac{W}{\pi(A' - A)} \left( \frac{R}{R - y_1} - \frac{A'}{A} \right) \text{ (compressive)} \quad \dots (6)$$

which is the greatest intensity of stress in the ring. At  $\theta = \frac{\pi}{2}$ , reversing the sign—

$$p = \frac{W \left( \frac{1}{2} - \frac{1}{\pi} \right)}{A' - A} \left( \frac{R}{R - y_1} - \frac{A'}{A} \right) + \frac{W}{2A} \text{ (tensile)} \quad \dots (7)$$

The intensity of stress reaches zero for a value of  $\theta$  which can be calculated from (5).

At the *extrados* or outer edge similarly, writing  $y = +y_2$ —

$$\text{intensity of tension } p = \frac{W \left( \frac{1}{\pi} - \frac{1}{2} \sin \theta \right)}{A' - A} \left( \frac{A'}{A} - \frac{R}{y_2 + R} \right) + \frac{W \sin \theta}{2A} \quad (8)$$

$$\text{At } \theta = 0^\circ, \quad p = \frac{W}{\pi(A' - A)} \left( \frac{A'}{A} - \frac{R}{y_2 + R} \right) \text{ (tensile)} \quad \dots (9)$$

At  $\theta = \frac{\pi}{2}$ , reversing the sign—

$$p = \frac{W \left( \frac{1}{2} - \frac{1}{\pi} \right)}{A' - A} \left( \frac{A'}{A} - \frac{R}{y_2 + R} \right) - \frac{W}{2A} \text{ (compressive)} \quad \dots (10)$$

and the position of the zero stress can be calculated from (8).

In rings the mean radius of which is large compared to the dimensions of cross-section, equation (7) will give the greatest tension in the ring, and as  $R$  increases, and the curvature decreases, this must approach the same magnitude as (6). When  $R$  is small, owing to the greater curvature the greatest tension may be given by (9); the critical radius  $R$  above which the tensile intensity (7) exceeds the intensity (9) may be found by equating (9) and (7) and solving the equation for  $R$ . For any symmetrical section with half-depth  $y_1$  this gives—

$$R = \frac{\pi}{4 - \pi} y_1 \quad \text{or} \quad 3.66 y_1$$

Taking the more exact value of the bending moments below, we find similarly that the critical radius is—

$$R = \frac{\pi}{4 \frac{A}{A'} - \pi} y_1$$

a somewhat greater value, since  $A$  is less than  $A'$ . For a circular section of radius  $r$  this gives—

$$R = 3.96 r$$

For rings of larger radius than this the tension at the extrados in the line of pull is the greatest tension in the ring, and for rings of smaller radius the tension at the intrados for the sections perpendicular to the line of pull is the greatest tension in the ring.

The intensity of stress at the intrados and extrados is shown for all angles in a particular case of a small ring in Fig. 178. (For details see Ex. 1 below.)

*More exact Estimate of Bending Moments.*—In estimating the bending moments, the initial curvature of the ring and the effect of the normal forces  $\frac{W}{2} \sin \theta$  were neglected, as the error involved is small; to take account of these, we proceed as follows.

Substituting the value (1) in (14) of Art. 129, with the same notation as in Art. 129, we have—

$$M = M_1 + \frac{WR}{2} (1 - \sin \theta) = ER^2 (1 + e_0) \left( \frac{1}{\rho} - \frac{1}{R} \right) (A' - A) \quad (11)$$

Hence, writing  $ds$  for  $Rd\theta$ —

$$\int_0^{\frac{\pi}{2}} M d\theta = ER(A' - A) \left\{ \int_{\theta=0}^{\theta=\frac{\pi}{2}} \frac{1 + e_0}{\rho} ds - \int_0^{\frac{\pi}{2}} (1 + e_0) d\theta \right\} \quad (12)$$

But evidently in a complete quadrant after strain the total angle between two normals  $OS$  and  $OL$ —

$$\int_{\theta=0}^{\theta=\frac{\pi}{2}} \frac{(1 + e_0) ds}{\rho} = \frac{\pi}{2}$$

hence (12) becomes—

$$\int_0^{\frac{\pi}{2}} M d\theta = ER(A' - A) \left\{ \frac{\pi}{2} - \frac{\pi}{2} - \int_0^{\frac{\pi}{2}} e_0 d\theta \right\} = -ER(A' - A) \int_0^{\frac{\pi}{2}} e_0 d\theta \quad (13)$$

and instead of the relations (6) or (8) or (13) of Art. 129, the total normal force across the section in this case is—

$$\frac{W}{2} \sin \theta = E \Sigma(e \cdot \delta a) = E \left\{ R(1 + e_0) \left( \frac{1}{\rho} - \frac{1}{R} \right) (A - A') + e_0 A \right\} \quad (14)$$

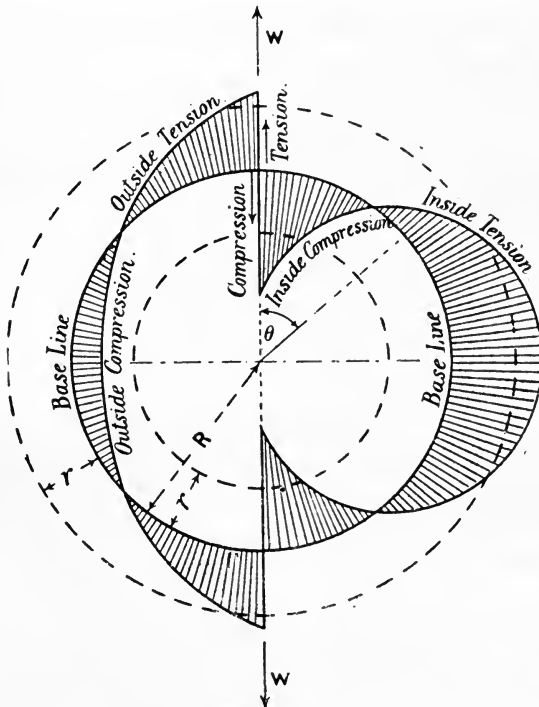

FIG. 178.

which with (11) gives—

$$e_0 = \frac{M_1}{EAR} + \frac{WR}{2EA} \text{ (which is independent of } \theta \text{)} \quad (15)$$

Substituting this value in (13)—

$$\int_0^{\frac{\pi}{2}} M \cdot d\theta = -\frac{\pi}{2} \cdot \frac{A' - A}{A} \left( M_1 + \frac{WR}{2} \right) \dots \quad (16)$$

But integrating (1)—

$$\int_0^{\frac{\pi}{2}} M d\theta = M_1 \frac{\pi}{2} + \frac{WR}{2} \left( \frac{\pi}{2} - 1 \right) \dots \dots (17)$$

Hence, equating (16) and (17)—

$$M_1 = \frac{WR}{\pi} \left( \frac{A}{A'} - \frac{\pi}{2} \right) \dots \dots (18)$$

instead of the value (2), and substituting this value in (1)—

$$M = WR \left( \frac{1}{\pi} \frac{A}{A'} - \frac{1}{2} \sin \theta \right) \dots \dots (19)$$

instead of the value (3), and in particular at  $\theta = 0$ , the maximum bending moment—

$$M_0 = \frac{WR}{\pi} \cdot \frac{A}{A'} \text{ or } 0.318WR \frac{A}{A'} \dots \dots (20)$$

a value lower than (4) since  $A$  is less than  $A'$ . Thus the bending moment at any point of the ring is dependent upon the ratio between the cross-sectional dimensions of the ring and its mean radius, and not only upon the external force  $W$  and the mean radius of the rings as indicated in (3). The use of these corrected values of  $M$  in deducing formulæ (5) to (10) will give slightly more correct values for the intensities of stress; it will be sufficient to notice that the greatest intensity of stress, viz. the bending stress at the point of application of the load in the intrados, instead of (6), becomes—

$$p = \frac{W}{\pi(A' - A)} \left( \frac{R}{R - y_1} \cdot \frac{A}{A'} - 1 \right) \dots \dots (21)$$

a rather lower value, since  $A$  is less than  $A'$ .

A very close approximation to the above corrected bending moments may be obtained, taking account of the bending which results from the normal forces  $\frac{W}{2} \sin \theta$  on the radial cross-sections. The normal force  $\frac{W}{2} \sin \theta$  causes a strain  $\frac{W \sin \theta}{2AE}$ , and an element of length  $ds$  is stretched by an amount  $\frac{W \sin \theta}{2AE} \cdot ds$ . Dividing by  $R$ , the bending or change of direction in a length  $ds$  is  $\frac{W \sin \theta}{2AE} \cdot d\theta$  approximately, and in a complete quadrant between  $A$  and  $F$  this amounts to—

$$\frac{W}{2AE} \int_0^{\frac{\pi}{2}} \sin \theta d\theta = \frac{W}{2AE} = \frac{Wk^3}{2EI}, \text{ where } k^3 = \frac{I}{A}$$

Adding this term to the equations above (2), we get—

$$M_1 = \frac{WR}{\pi} \left( 1 - \frac{\pi}{2} - \frac{k^2}{R^2} \right) \quad \text{and} \quad M_0 = \frac{WR}{\pi} \left( 1 - \frac{k^2}{R^2} \right) \quad (22)$$

results which may also be obtained by substituting the approximate values of  $A'$  from (4), Art. 130, in (18) and (20) of the present article.

EXAMPLE 1.—A ring is subjected to a pull the line of which passes through its centre. If the ring is made of round steel the radius of which is  $\frac{1}{3}$  of the mean radius of the ring, find the intensity of stress at the inside and outside of the ring. (This represents the smallest ring which could be used as a link in connection with other links of the same size.)

The radius of the round steel being  $r$  and the mean radius of the ring  $R = 3r$ , from Art. 130 (3)—

$$\begin{aligned} A' &= 6\pi r^2(3 - \sqrt{8}) = 1.0294\pi r^2 & A &= \pi r^2 \\ A' - A &= 0.0294\pi r^2 & \frac{A'}{A} &= 1.0294 \end{aligned}$$

using the approximate values of the bending moments.

*Intrados.*—From (5), Art. 133, the intensity of compressive stress—

$$p = \frac{W \left( \frac{1}{\pi} - \frac{1}{2} \sin \theta \right)}{0.0294\pi r^2} (1.5 - 1.0294) - \frac{W \sin \theta}{2\pi r^3} = \frac{W}{\pi r^2} \left( \frac{16}{\pi} - 8.5 \sin \theta \right)$$

The values of  $p$  are shown plotted radially inwards for positive quantities from the central line on the right-hand side of Fig. 178.

The maximum value at  $\theta = 0$  is—

$$\frac{16}{\pi} \cdot \frac{W}{\pi r^2} \quad \text{or} \quad 5.10 \frac{W}{\pi r^2}$$

If the more exact value  $\frac{A'}{A} \cdot \frac{WR}{\pi}$  is adopted for the bending moment in the line of loading the maximum stress intensity becomes  $\frac{16}{\pi} \cdot \frac{W}{\pi r^2} \times \frac{1}{1.0294} = 4.95 \frac{W}{\pi r^2}$ , the difference being under 3 per cent. even in this extreme case of curvature. The value (22) gives  $\frac{16}{\pi} \cdot \frac{W}{\pi r^2} \times \left( 1 - \frac{1}{36} \right) = 4.96 \frac{W}{\pi r^2}$ , showing the very close agreement of (22) with (20).

If  $W = 1$  ton and the steel is 1 inch diameter, the maximum intensity of stress is  $\frac{4.95}{0.7854} = 6.3$  tons per square inch.

If the rule applicable to the bending stress in straight beams ((6), Art. 63) had been used, the equal and opposite intensities of stress would be, using the approximate bending moment—

$$\frac{WR}{\pi} \times \frac{4}{\pi r^3} = \frac{12}{\pi} \cdot \frac{W}{\pi r^2}$$

The value  $\frac{16}{\pi} \frac{W}{\pi r^2}$  is 33 per cent. greater than this.

*Extrados.*—From (8), Art. 133, the intensity of tensile stress is—

$$p = \frac{W \left( \frac{1}{\pi} - \frac{1}{2} \sin \theta \right)}{0.0294 \pi r^2} (1.0294 - 0.75) + \frac{W \sin \theta}{2 \pi r^2} = \frac{W}{\pi r^2} \left( \frac{9.497}{\pi} - 4.248 \sin \theta \right)$$

These values are shown plotted radially from the central line on the left-hand side of Fig. 178.

The greatest stress arising from the radial shearing force is at the central line of the section in the line of pull, and is about  $\frac{4}{3} \cdot \frac{W}{2 \pi r^2}$ , which is much less than the extreme bending stresses on the same section. For points within the perimeter of other sections the principal stresses may be estimated approximately from the radial and circumferential shear stress, distributed as in Art. 71, the direct stress  $\frac{W \sin \theta}{2 \pi r^2}$ , and the bending stress estimated by, say, (16*b*), Art. 129; such principal stresses are everywhere of lower intensity than the maximum bending stresses calculated above.

**134. Deformation of Curved Bar.**—The bending of a curved bar results in an alteration in the shape, and in particular, chords joining

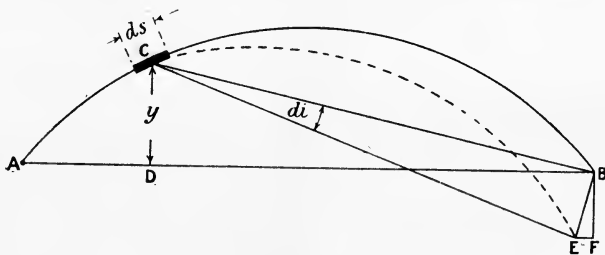

FIG. 179.

points on the original centre line may be considerably altered in length. Let ACB (Fig. 179) represent the centre line of a curved bar which is subjected to a variable bending moment. To find the alteration in the length AB, consider the effect of the bending of an element of length  $ds$ ; if the remaining part of the bar were unchanged while the element  $ds$  turned through an angle  $di$ , A being supposed fixed, B would move to E, the horizontal projection of this displacement being—

$$EF = EB \cos \hat{BEF} = CB \cdot di \cdot \cos \hat{BEF} = di \cdot CB \cos \hat{BCD} = DC \cdot di \text{ or } y \cdot di$$

And from Art. 77 the change of curvature—

$$\frac{di}{ds} = \frac{M}{EI} \text{ or } di = \frac{M}{EI} ds$$



where I is the moment of inertia of cross-section, and E is the modulus of direct elasticity.

Hence the alteration EF in the chord AB resulting from the bending of the element  $ds$  is—

$$\frac{M}{EI} \cdot y \cdot ds$$

and the total alteration due to bending is—

$$\int \frac{My}{EI} \cdot ds \dots \dots \dots (1)$$

the integral or sum being taken between limits corresponding to the ends A and B. Bending moments producing greater curvature evidently cause decrease of length of the chord, and those producing decrease of curvature cause increase in length.

135. Deformation of Ring.<sup>1</sup>—From the result of Art. 134, it is easy to estimate approximately the change in the principal diameters due to bending of the ring, considered in Art. 133. Thus, using Fig. 176, putting  $y = R \cos \theta$ ,  $ds = R d\theta$ , and from (3), Art. 133,  $M = WR \left( \frac{1}{\pi} - \frac{1}{2} \sin \theta \right)$  in (1) of Art. 134, the decrease in the diameter KL is—

$$2 \int_0^{\frac{\pi}{2}} \frac{WR}{EI} \left( \frac{1}{\pi} - \frac{1}{2} \sin \theta \right) R \cos \theta R d\theta = \frac{2WR^3}{EI} \left( \frac{1}{\pi} - \frac{1}{4} \right) \dots (1)$$

or if the more exact value (19) of Art. 133 is used for M, the decrease is—

$$\frac{2WR^3}{EI} \left( \frac{A}{A'} \frac{1}{\pi} - \frac{1}{4} \right) \dots \dots \dots (2)$$

The alteration in the diameter ST may similarly be found by writing  $y = R \sin \theta$  instead of  $R \cos \theta$ ; the decrease is—

$$2 \int_0^{\frac{\pi}{2}} \frac{WR}{EI} \left( \frac{1}{\pi} - \frac{1}{2} \sin \theta \right) \sin \theta R d\theta = \frac{2WR^3}{EI} \left( \frac{1}{\pi} - \frac{\pi}{8} \right) \text{ (a negative quantity)}$$

or the *increase* is—

$$\frac{2WR^3}{EI} \left( \frac{\pi}{8} - \frac{1}{\pi} \right) \dots \dots \dots (3)$$

or using the more exact value (19), Art. 133, for M, the increase is—

$$\frac{2WR^3}{EI} \left( \frac{\pi}{8} - \frac{1}{\pi} \frac{A}{A'} \right) \dots \dots \dots (4)$$

<sup>1</sup> Since this chapter was written the Author has received from the University of Illinois a bulletin containing an account of experimental tests of this theory of rings and chain links by measurements of the deformations; the agreement between calculation and experiment is very striking.

The alteration of diameter (4) in the direction of the pull is of greater magnitude than the alteration (2) perpendicular to the pull.

*Effect of Normal Forces.*—The alterations in the principal mean diameters given above are those due to bending only, and are much the most important part of the whole change. To take account of the alteration due to the normal stress at the central line, we have, from (15) and (18) of Art. 133—

$$e_0 = \frac{W}{\pi EA'}$$

and due to the normal force the total *increase* of diameters KL and ST is—

$$\begin{aligned} 2 \int_{\theta=0}^{\theta=\frac{\pi}{2}} \sin \theta \cdot e_0 \cdot ds &= 2 \int_{\theta=0}^{\theta=\frac{\pi}{2}} \cos \theta \cdot e_0 \cdot ds = 2 \frac{WR}{\pi EA'} \int_0^{\frac{\pi}{2}} \cos \theta d\theta \\ &= \frac{2WR}{\pi EA'} \dots \dots \dots (5) \end{aligned}$$

Hence the *total decrease* in the diameter KL perpendicular to the line of pull is—

$$\frac{2WR^3}{EI} \left( \frac{A}{A'} \frac{1}{\pi} - \frac{1}{4} \right) - \frac{2WR}{\pi EA'} \dots \dots \dots (6)$$

and the total *increase* in the diameter ST in the line of pull is—

$$\frac{2WR^3}{EI} \left( \frac{\pi}{8} - \frac{1}{\pi} \frac{A}{A'} \right) + \frac{2WR}{\pi EA'} \dots \dots \dots (7)$$

The last terms in (6) and (7) will generally be small in comparison with the remainder; they will only be important when R is small.

**EXAMPLE.**—Calculate the increase in length in the ring in Ex. 1, Art. 133. Take the total load as 1 ton, the ring 3 inches mean diameter, and E = 12,660 tons per square inch.

Using the values previously obtained—

$$I = \frac{\pi r^4}{4} \quad A = \pi r^2 \quad A' = 1.0294\pi r^2 \quad R = 3r$$

and substituting in (7), the increase in diameter is—

$$\begin{aligned} \frac{54Wr^3}{E\pi r^4} \times 4 \left( \frac{\pi}{8} - \frac{1}{1.0294\pi} \right) + \frac{6Wr}{E\pi^2 \times 1.0294r^2} \\ = \frac{W}{Er} (27 - 21.26 + 0.59) = \frac{W}{Er} (5.74 + 0.59) = \frac{6.33W}{Er} \end{aligned}$$

In this extreme case of great curvature the stretch due to the normal pull is over  $\frac{1}{10}$  that due to bending.

Substituting the numerical values W = 1, r =  $\frac{1}{2}$ , and E = 12,660, the increase in diameter is—

$$\frac{6.33 \times 1 \times 2}{12,660} = 0.001 \text{ inch}$$

**136. Simple Chain Links.**—The simplest form of chain link is that which has semicircular ends and straight sides connecting them. We may extend the approximate theory of stress calculations for the ring in Art. 133 to make at least a useful estimate of the intensity of stress in a simple chain link.

Let  $R$  be the mean radius of the semicircular ends, and  $l$  the length of the straight sides, the other quantities being as in Art. 133, and as shown in Fig. 180. Then in the ends at a section XX—

$$M = M_1 + \frac{W}{2}R(1 - \sin \theta) \quad (1)$$

where  $M_1$  is the bending moment at the section UV and in all the straight parts of the link. Again using the relation of Art. 77, since the total bending or change from original direction between A and F is zero—

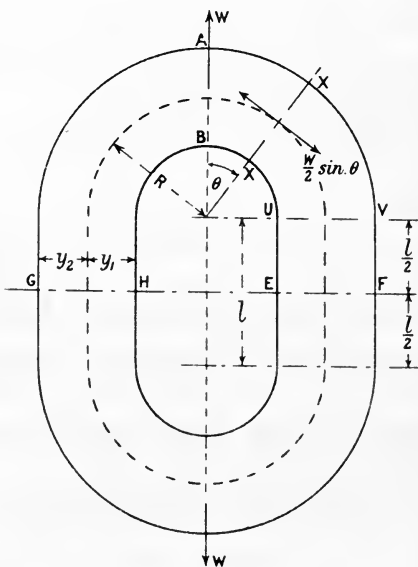

FIG. 180.

$$\int_{\theta=0}^{\theta=\frac{\pi}{2}} \frac{M}{EI} ds + \frac{M_1}{EI} \times \frac{l}{2} = 0$$

the second term representing the angular change of direction or bending in a length  $\frac{l}{2}$  from V to F. Hence, substituting for  $M$  and for  $ds$  as in

Art. 133—

$$\frac{R}{EI} \int_0^{\frac{\pi}{2}} \left\{ M_1 + \frac{WR}{2}(1 - \sin \theta) \right\} d\theta + \frac{M_1 l}{2EI} = 0$$

$$RM_1 \frac{\pi}{2} + \frac{WR^2 \pi}{4} - \frac{WR^2}{2} + M_1 \frac{l}{2} = 0$$

hence 
$$M_1 = \frac{WR^2}{2} \left( \frac{2 - \pi}{\pi R + l} \right) \quad \text{or} \quad \frac{WR}{2} \left( \frac{2R - \pi R}{\pi R + l} \right) \dots (2)$$

a negative value, which reduces to the form (2), Art. 133, when  $l = 0$  and is smaller for all other values of  $l$ .

Substituting this value of  $M_1$  in (1)—

$$M = \frac{WR^2}{2} \frac{2 - \pi}{\pi R + l} + \frac{W}{2} R(1 - \sin \theta) = \frac{WR}{2} \left( \frac{2R + l}{\pi R + l} - \sin \theta \right) \quad (3)$$

and in particular at AB, where  $\theta = 0$ —

$$M_0 = \frac{WR}{2} \cdot \frac{2R + l}{\pi R + l} \cdot \dots \dots \dots (4)$$

which is evidently always of opposite sign and greater magnitude than (2), since  $l$  is always positive. Moreover,  $M_0$  increases with increase of  $l$ , from  $\frac{WR}{\pi}$  when  $l = 0$ , towards  $\frac{WR}{2}$  when  $l$  is very great.

The intensity of bending stress at the intrados and extrados of the curved ends may be found by substituting the above values in (16*b*) of Art. 129. There is, in addition, the tension  $\frac{W}{2A} \sin \theta$  to be added algebraically to the bending stress. At the section AB the intensity of compressive stress at the inside (B) is—

$$\frac{M_0}{R(A' - A)} \left( \frac{R}{R - y_1} - \frac{A'}{A} \right) = \frac{W(2R + l)}{2(\pi R + l)(A' - A)} \left( \frac{R}{R - y_1} - \frac{A'}{A} \right) \quad (5)$$

where  $y_1$  is the distance from the central line to the inside edge B. The bending stress in the straight portion is that resulting from a bending moment  $M_1$ . There is also a tension  $\frac{W}{2A}$  to be added algebraically to the bending stress. At all sections, including EF, the intensity of tension at the inside edge is—

$$-\frac{M_1 y_1}{I} + \frac{W}{2A} = \frac{W}{2} \left\{ \frac{y_1 R^2 (\pi - 2)}{I(\pi R + l)} + \frac{1}{A} \right\} \dots \dots (6)$$

For symmetrical cross-sections, in which  $y_2 = y_1$  even in the smallest link practicable (see Ex. 1 below), this value (6) is less than the tension at the point A at the outside of the section AB, which is, by (16*b*) of Art. 129—

$$\frac{M_0}{R(A' - A)} \left( \frac{A'}{A} - \frac{R}{y_2 + R} \right) = \frac{W(2R + l)}{2(\pi R + l)(A' - A)} \left( \frac{A'}{A} - \frac{R}{y_2 + R} \right) \quad (7)$$

Again, just in the curved portion above U, including the direct pull, the intensity of tension at the inside edge would be—

$$-\frac{M_1}{R(A' - A)} \left( \frac{R}{R - y_1} - \frac{A'}{A} \right) + \frac{W}{2A} = \frac{W}{2} \left\{ \frac{(\pi R - 2R)}{(\pi R + l)(A' - A)} \left( \frac{R}{R - y_1} - \frac{A'}{A} \right) + \frac{1}{A} \right\} \dots (8)$$

This value (8) being for a curved portion will always exceed the value (6) for a straight portion under the same bending moment and

direct stress; whether or not it will exceed the value (7) depends upon the ratio of both  $R$  and  $l$  to the dimensions of cross-section. In the smallest practicable link (8) is the greatest tension (see Ex. 1 below); in more usual sizes, (7) gives the maximum tension in the link, being a little greater than (8).

There would, according to these approximate estimates, be a sudden discontinuity in the bending stress at the section  $UV$ , where the radius of curvature suddenly changes from  $R$  to an infinite value. The method is, however, only approximate, and we may take the values (6) and (8) as holding approximately at short distances on either side of the section  $UV$ ; the stresses (5) and (7) are usually most important.

If we make the more exact calculation of bending moment as for the ring at the end of Art. 133, the total change in a quadrant being—

$$\int_{\theta=0}^{\theta=\frac{\pi}{2}} \frac{(1 + e_0) ds}{\rho} = \frac{\pi}{2} - \frac{M_1 l}{2EI} \text{ instead of } \frac{\pi}{2}$$

we find, using the first approximation from (4), Art. 130, for  $I$ —

$$M_0 = \frac{WR}{2} \frac{2R + l}{\frac{A'}{A} \pi R + l} \text{ (very nearly)}$$

This gives a maximum bending moment rather below the value (4). In this approximate theory, this correction, which affects the bending stresses (5), (6), (7), and (8) slightly, does not seem worth making. The deformation of the link may be estimated by the methods of the previous article, using the proper values of  $M$  and  $e_0$ , and using separate integrations over the curved and straight portions.

**EXAMPLE 1.**—Estimate the stresses on the principal sections of a link having semicircular ends and straight sides, made of round iron, the mean radius of the ends of the links being equal to the diameter of the round iron, and the length of the straight sides being also equal to the diameter of the sections. (This represents the shortest and most curved link which it would be possible to use in a chain with others of the same kind.)

Taking  $r$  as the radius of the section, the mean radius of the ends  $R = 2r = l$ ,  $A = \pi r^2$ . And from Art. 130 (3)—

$$A' = 4\pi r^2(2 - \sqrt{3}) = 1.0718\pi r^2 \quad A' - A = 0.0718\pi r^2 \quad \frac{A'}{A} = 1.0718$$

For the section in the plane of the pull, the intensity of compressive stress inside, putting  $y_1 = r$  in (5), is—

$$\frac{6Wr}{2r(2\pi + 2) \times 0.0718\pi r^2} (2 - 1.0718) = \frac{W}{\pi r^2} \cdot \frac{3 \times 0.9282}{2(\pi + 1) \times 0.0718} = 4.68 \frac{W}{\pi r^2}$$

If  $W = 1$  ton, and the iron is 1 inch diameter, the compressive stress is  $\frac{4.68}{0.7854} = 5.97$  tons per square inch.

These results should be compared with those for the ring in the example at the end of Art. 133.

The *tensile* stress intensity at the outside of the same section from (7) is—

$$\frac{6Wr}{4r(\pi + 1) \times 0.0718\pi r^2} (1.0718 - \frac{2}{3}) = 2.04 \frac{W}{\pi r^2}$$

The tensile stress at the inside of the straight sides is, from (6)—

$$\frac{Wr \cdot 4r^2(\pi - 2) \times 4}{2 \times 2(\pi + 1)\pi r^4} + \frac{W}{2\pi r^2} = \frac{W}{\pi r^2} (1.10 + 0.5) = 1.60 \frac{W}{\pi r^2}$$

The *tensile* stress at the inside of the sections where the straight sides join the curved ends is, from (8)—

$$\frac{Wr(\pi - 2)}{2r(\pi + 1)(0.0718\pi r^2)} (2 - 1.0718) + \frac{W}{2\pi r^2} = \frac{(1.78 + 0.5)W}{\pi r^2} = \frac{2.28W}{\pi r^2}$$

which is the greatest tension anywhere in the link.

A small increase in the length of the sides and radius of the ends is necessary to make a link which would work freely, and such increase is sufficient to make the tensile stress greatest at the outside of the sections in the line of pull.

**137. Flat Spiral Springs.**—The relation between the straining actions and the winding up of a spiral spring such as is used to drive various mechanisms may be determined as follows. Suppose one end A of the spring (Fig. 181) to be free and pulled with a force P in the direction AB, the other end being attached to a small spindle C. The bending moment at any elementary length *ds* of the spring, distant *x* from the line AB, is—

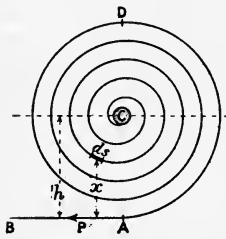

FIG. 181.

$$M = Px$$

The angular winding due to this element is given by—

$$\frac{di}{ds} = \frac{M}{EI} \text{ or } di = \frac{M}{EI} \cdot ds = \frac{Px}{EI} \cdot ds$$

where *di* is the change in the angle between the tangents at the two ends of the elements *ds*, and *I* is the moment of inertia of the cross-section about a central axis perpendicular to the plane of the figure. Hence the total angle of winding up due to the force P is—

$$i = \sum \left( \frac{Px}{EI} ds \right) \text{ or } \frac{P}{EI} \int x ds \text{ (radians) . . . . (1)}$$

if *I* is constant, as is usual. The quantity  $\int x ds$  is what may be called the moment of the profile of the spring about the line AB, or the whole length of spring *l* multiplied by the distance of its centre of gravity

from AB; this distance is practically equal to  $h$ , the distance of the centre of the spindle C from AB, so that—

$$\int x ds = h \cdot l$$

and 
$$i = \frac{Phl}{EI} \text{ or } \frac{Ml}{EI} \text{ (radians) . . . . . (2)}$$

where  $M = Ph$ .

In an actual spring the point A is usually fixed and the spindle C is turned, the action of winding up bringing into play a force  $P$  nearly parallel to AB, and an equal and opposite force through C, forming a couple  $P \times AC$  or  $Ph$ . So long as the spring at A remains sensibly normal to CA, and no two parts of the spring come into contact, and the shape remains such that the centre of gravity is at C, the above relations will remain practically true. The angle  $i$  is proportional to  $P$  or  $M$ , and consequently the work stored in winding, or the resilience of the spring, from (8), Art. 93, is—

$$\frac{1}{2} M \cdot i = \frac{1}{2} \cdot \frac{M^2 l}{EI} = \frac{1}{2} \frac{P^2 h^2 l}{EI} \text{ . . . . . (3)}$$

where  $M = Ph$ , the external moment applied.

The greatest bending stress on the spring may occur where the spring joins the spindle if the curvature there is very great, but it will usually occur about D diametrically opposite to A, where the bending moment is greatest. If the spring is very thin, we may neglect the curvature and calculate the bending stress as for a straight beam. At D the bending moment is nearly  $P \times 2h$ , hence the greatest intensity of bending stress is  $\frac{2Ph}{Z}$ , where  $Z$  is the modulus of section for bending.

If the spring is rectangular in cross-section, the depth or thickness being  $d$  and the breadth  $b$ ,  $Z = \frac{1}{6}bd^2$ , and the intensity of bending stress at D is nearly—

$$p = \frac{12Ph}{bd^2} = \frac{12M}{bd^2}$$

If the safe or proof-stress intensity is  $f$ , the maximum value of  $P$  is—

$$\text{(max.) } P = \frac{f \cdot bd^2}{12h} \text{ or } M = \frac{f \cdot bd^2}{12}$$

and substituting this in (3),  $I$  being  $\frac{1}{12}bd^3$ —

$$\text{proof resilience} = \frac{1}{24} \frac{f^2}{E} \times bdl \text{ or } \frac{1}{24} \frac{f^2}{E} \times \text{volume (nearly)}$$

or about  $\frac{1}{24} \frac{f^2}{E}$  per unit of volume, which is only  $\frac{1}{4}$  of that of a closely wound helical spring subject to axial twist (Art. 117), where all the material is subjected to the maximum bending moment instead of a bending moment varying from zero to a maximum with a mean value about half of the maximum.

EXAMPLE 1.—A flat spiral spring is  $\frac{1}{2}$  inch broad,  $\frac{1}{40}$  inch thick, and 10 feet long. One end is attached to a small spindle, and the other to a fixed point. If the spring is "run down," or in a state of ease, find what turning moment on the spindle is required to give three complete turns to the spring. How much work is done in winding, and what is approximately the greatest stress in the spring? ( $E = 30 \times 10^6$  lbs. per square inch.)

$$I = \frac{1}{12} \times \frac{1}{2} \times \left(\frac{1}{40}\right)^3 = \frac{1}{1,536,000} \text{ (inch)}^4 \quad i = 6\pi \text{ radians}$$

From (2)—

$$M = \frac{EI \cdot i}{l} = \frac{30 \times 10^6 \times 6\pi}{1,536,000 \times 120} = 3.068 \text{ lb.-inches}$$

• The work done is—

$$\frac{1}{2}M \times 6\pi = 3.068 \times 3\pi = 28.91 \text{ inch-pounds}$$

The maximum bending moment is nearly  $2 \times 3.068$ , and the bending-stress intensity is nearly—

$$\frac{2 \times 3.068 \times 6}{\frac{1}{2} \times \left(\frac{1}{40}\right)^2} = 117,800 \text{ pounds per square inch}$$

**138. Arched Ribs.**—Curved beams, usually of metal, are frequently used in roofs and bridges, and are called arched ribs. The straining actions at any normal cross-section are conveniently resolved into a bending moment and a shearing force, as in the case of a straight beam carrying transverse loads, with the addition in the arched rib of a thrust perpendicular to the section; for, unlike the case of the straight beam, the loads not being all perpendicular to the axis of the rib, the resultant force perpendicular to a radial cross-section is not zero. Thus, at a section AB (Fig. 182) of an arched rib the external forces give rise to (1) a thrust P through the centroid C, (2) a shearing force F on the section AB, and (3) a bending moment M. These three actions

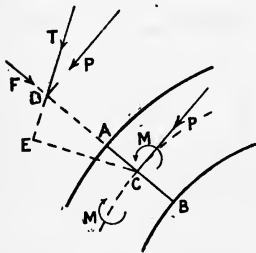

FIG. 182.

are statically equivalent to a single thrust T, through a point D, in the section AB produced, where T is the resultant of the rectangular components F and P, and the distance  $CD = \frac{M}{P}$ . The curve to which the

line of thrust is everywhere tangent at points vertically above the centroids is called the *linear arch* for the rib. The straining action may thus be specified by the normal thrust, the shearing force, and the bending moment, or simply by the linear arch, and when the straining actions are known, the stress intensities in the rib can be calculated. As in straight beams, the shearing force may often be neglected as



producing little effect on the stresses. The bending stresses might be calculated as in Art. 129 if the curvature of the rib is great, but usually it is sufficient to calculate them as for a straight beam, as in Art. 63. The uniform compression arising from the thrust  $P$  is added algebraically to the bending stress, as in Arts. 97 and 98, and the radial and circumferential shearing stress arising from the shearing force may be calculated as in Art. 71, and, if necessary, combined with the bending and other direct stress to find the principal stresses, as in Arts. 73, 113, and 114. Arched rib may generally be taken as bridging horizontal spans and sustaining vertical loads, and three cases will be considered.

**139. Arched Rib hinged at Ends and Centre.**—A rib hinged at the two supports or springings  $AB$  and at the crown  $C$ , and loaded with vertical forces only, is

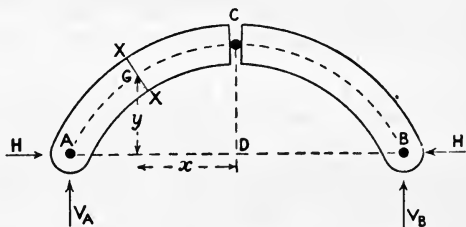

FIG. 183.

shown in Fig. 183. The reactions at  $A$  and  $B$  may conveniently be divided into vertical components  $V_A$  and  $V_B$ , together with the horizontal component  $H$ , which must be the same at both ends, since these two are the only external horizontal forces to which the rib is sub-

jected, and consequently the *horizontal* thrust is constant and equal to  $H$  throughout the rib. The vertical components  $V_A$  and  $V_B$  may be found in exactly the same manner as the vertical reactions of a horizontal beam with transverse loads (Arts. 56 and 57) by taking moments of the external forces about  $A$  or  $B$ . The constant horizontal component thrust is found in this case from the fact that at the hinge  $C$  the bending moment is necessarily zero, and therefore the moment about  $C$  of the horizontal thrust  $H$  must be equal and opposite to the moment of the vertical forces from  $A$  to  $C$ , including the vertical component  $V_A$  of the reaction at  $A$ . If  $\mu$  denotes the bending moment calculated for the vertical forces only, as for a straight horizontal beam, and at  $C$  (Fig. 184)  $\mu = \mu_C$ , represented by the ordinate  $ED$ —

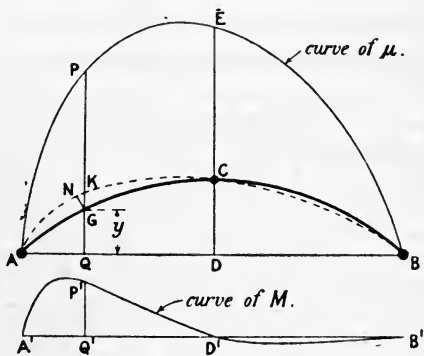

FIG. 184.

calculated for the vertical forces only, as for a straight horizontal beam, and at  $C$  (Fig. 184)  $\mu = \mu_C$ , represented by the ordinate  $ED$ —

$$H = \frac{\mu_C}{CD} \dots \dots \dots (1)$$

Then at any other section of which G (Fig. 184) is the centroid, and  $y$  its height above the line AB, the moment M is—

$$M = \mu - Hy = \mu - \frac{\mu_0}{CD} \cdot y \dots \dots \dots (2)$$

where bending moments producing *decreased* convexity upwards or *decreased curvature* are reckoned positive instead of the opposite convention of signs adopted for straight beams in Art. 77.

If, therefore, a diagram of the bending moments  $\mu$  as for a straight horizontal beam be plotted, and every ordinate be reduced by  $H \cdot y$  or  $\frac{\mu_0 \cdot y}{CD}$ , the resulting ordinates, such as P'Q' (Fig. 184), will give the values of the actual bending moments M on same scale as the curve of  $\mu$ , or (2) may be written—

$$P'Q' = PQ - \frac{ED}{CD} \cdot GQ$$

A slightly different method of obtaining the bending moment from the curve of  $\mu$  is to draw the linear arch. If each term of (2) be multiplied by  $\frac{CD}{\mu_0}$  or  $\frac{CD}{ED}$ ,

$$M \times \frac{CD}{ED} = \mu \cdot \frac{CD}{ED} - y \dots \dots \dots (3)$$

Hence, if the ordinates, such as PQ, of the curve APEB of  $\mu$ , are reduced in the ratio  $\frac{CD}{ED}$ , the difference, such as GK, between the resulting ordinates and the ordinates  $y$ , represents  $M \times \frac{CD}{ED}$  on the same scale as before, or represents M on a scale in which the bending moment represented by unit length is increased in the ratio  $\frac{ED}{CD}$ . The bending moment in such a case is measured vertically from the curved base AGCB, but to the modified instead of the original scale. Or (2) may be written—

$$M = H \left( \frac{\mu}{H} - y \right) = H \left( \frac{CD}{\mu_0} \mu - y \right) = H(QK - GQ) = H \times KG$$

hence the bending moment is everywhere equal to the horizontal thrust multiplied by the vertical distance between the linear arch and the centre line of the arch. This is called *Eddy's Theorem*.

The line ANKCB is the linear arch, and the normal thrust P may be found by dividing the bending moment M by the perpendicular distance GN of G from the tangent at K to the linear arch (see Art. 138), and the scale is such that—

$$P = H \times \frac{GK}{NG} \dots \dots \dots (4)$$

In the neighbourhood of points of maximum bending moment the linear arch is parallel to the arched rib, and the resultant and normal thrusts are then practically the same.

The resultant thrust may also be obtained by compounding the

constant horizontal thrust  $H$  with the *vertical* shearing force determined as for a straight horizontal beam.

It is evident that if the centre line of the arched rib is of the same form as the curve of  $\mu$ , the bending moment  $M$  is everywhere zero, e.g. in the case of an arched rib carrying a load uniformly spread over the length of span the bending-moment diagram of  $\mu$  is a parabola (Art. 57, Fig. 65) symmetrically placed with its axis perpendicular to and bisecting the span; if the rib is also such a parabola the bending moment is everywhere zero.

The determination of the linear arch, bending moment, and normal thrust can often be very conveniently carried out graphically by means of a funicular polygon, the pole distance of which is determined by (1); these methods will be found more fully developed in treatises on Structures.

EXAMPLE 1.—A symmetrical parabolic arched rib has a span of 40 feet and a rise of 8 feet, and is hinged at the springings and crown. If it carries a uniformly spread load of  $\frac{1}{2}$  ton per foot run over the left-hand half of the span, find the bending moment, normal thrust, and shearing force at the hinges and at  $\frac{1}{4}$  span from each end.

Taking the origin at D, Fig. 183, the equation to the parabolic curve of the centroids is—

$$x^2 = c(8 - y) \quad \text{and at A, } x = 20 \quad y = 0 \quad \text{hence } c = 50$$

$$\text{and } x^2 = 50(8 - y) \quad \text{or } y = 8 - \frac{x^2}{50} \quad \frac{dy}{dx} = -\frac{x}{25}$$

which gives the tangent of slope anywhere on the rib.

The vertical components of the reactions are evidently—

$$V_A = \frac{3}{4} \times 20 \times \frac{1}{2} = 7.5 \text{ tons} \quad V_B = 2.5 \text{ tons}$$

Taking moments about C—

$$7.5 \times 20 - 10 \times 20 \times \frac{1}{2} - H \times 8 = 0 \quad H = 6.25 \text{ tons}$$

*Normal Thrust at A.*—

$$\text{Resultant thrust } R_A = \sqrt{(7.5)^2 + (6.25)^2} = 9.763 \text{ tons}$$

$$\text{Tangent of inclination to horizontal} = \frac{V_A}{H} = \frac{7.5}{6.25} = 1.2 = \tan 50.20^\circ.$$

Tangent of slope of rib from  $\frac{dy}{dx}$  is—

$$\frac{20}{25} = 0.8 = \tan 38.67^\circ$$

$$\text{Inclination of } R_A \text{ to centre line of rib} = 50.20 - 38.67 = 11.53^\circ.$$

$$\text{Normal thrust at A} = 9.763 \times \cos 11.53^\circ = 9.56 \text{ tons}$$

$$\text{Shearing force at A} = 9.763 \times \sin 11.53^\circ = 1.95 \text{ tons}$$

Between A and C at  $x$  feet horizontally from D—

$$M = 7.5(20 - x) - \frac{1}{4}(20 - x)^2 - 6.25y = 2.5x - \frac{1}{8}x^2$$

This reaches a maximum for  $x = 10$  when  $M = 12.5$  ton-feet. The

vertical shearing force is then  $7.5 - 10 \times \frac{1}{2} = 2.5$  tons (upward external to the left), the slopes of the rib and the thrust are the same, viz.  $\tan^{-1} 0.4$ , and the normal thrust is equal to the resultant thrust, viz.—

$$\sqrt{(6.25)^2 + (2.5)^2} = 6.73 \text{ tons.}$$

At the crown, vertical shearing force =  $7.5 - 10 = -2.5$  tons or 2.5 tons (downward external to the left).

$$\text{Thrust } T_c = \sqrt{(6.25)^2 + (2.5)^2} = 6.73 \text{ tons}$$

The direction and magnitude of the thrust on all the right-hand side of the rib is constant, being in the line BC.

At 10 feet from B the bending moment, which is evidently the maximum value on BC, is—

$$2.5 \times 10 - 6.25 \times 6 = -12.5 \text{ ton-feet}$$

*i.e.* 12.5 ton-feet tending to produce greater curvature of the rib.

$$\text{At B, tangent of inclination of thrust} = \frac{2.5}{6.25} = 0.4 = \tan 21.8^\circ$$

tangent of inclination of rib (as at A) is—

$$0.8 = \tan 38.67^\circ$$

Inclination of reaction at B to centre line of rib =  $38.67 - 21.8 = 16.87^\circ$ .

$$\text{Normal thrust at B} = 6.73 \cos 16.87^\circ = 6.44 \text{ tons}$$

$$\text{Shearing force at B} = 6.73 \sin 16.87^\circ = 1.95 \text{ tons}$$

**140. Arched Rib hinged at the Ends.**—A rib hinged at the ends only differs from one having three hinges, in that bending stress may

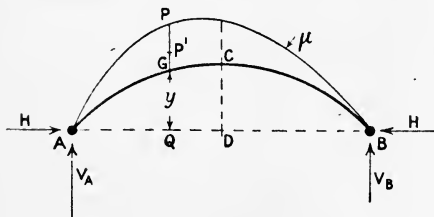

FIG. 185.

result from expansion or contraction of the rib if the hinged ends are rigidly fixed in position. The stresses in such a rib are statically indeterminate unless some condition beyond the zero bending moment at the two hinges is assumed. It is usual to suppose that before loading the rib is free from stress, and that after the load

is applied the hinged ends remain at the same distance apart as previously, *i.e.* the span remains unchanged. This condition allows of the horizontal thrust being calculated. With the notation of the previous article, let  $M$  be the bending moment at any cross-section of which  $G$ , Fig. 185, is the centroid; then—

$$M = \mu - H \cdot y \dots \dots \dots (1)$$

and from Art. 134 (1), the total increase of span, neglecting the effect of the normal thrust, is—

$$\int_A^B \frac{M \cdot y}{EI} ds = \int_A^B \frac{(\mu - Hy)y}{EI} ds$$

where I is the moment of inertia of cross-section and *ds* represents an element of the arc AGCB; and by the assumption that the hinges remain in the same position—

$$\int \frac{(\mu - Hy)y}{EI} ds = 0 \dots \dots \dots (2)$$

or, 
$$\int \frac{\mu}{EI} \cdot y ds = H \int \frac{y^2}{EI} ds$$

and 
$$H = \frac{\int \frac{\mu y}{EI} ds}{\int \frac{y^2}{EI} ds} \dots \dots \dots (3)$$

the summations being taken over the whole length of the rib. In a large built-up arched rib I will generally be variable, but if not, and E is constant, (3) reduces to—

$$H = \frac{\int \mu \cdot y ds}{\int y^2 ds} \dots \dots \dots (4)$$

If *y*,  $\mu$ , and *ds* can be expressed as functions of a common variable this value of H may be found by ordinary integration, and in any case it may be found approximately when the curve of  $\mu$  has been drawn by dividing the arc AGCB into short lengths  $\delta s$  and taking the sums of the products  $\mu \cdot y \cdot \delta s$  and  $y^2 \cdot \delta s$ , using values of  $\mu$  and *y* corresponding to the middle of the length  $\delta s$ . If I varies, products  $\frac{\mu}{I} y \cdot \delta s$  and  $\frac{y^2}{I} \cdot \delta s$  must be used in the summations.

In a circular arch *y*, *ds* and horizontal distances can easily be expressed as functions of the angle at the centre of curvature, and if the moment  $\mu$  can be expressed as in Chapter IV. as a function of horizontal distances along the span, the integrals in (4) can easily be found. In the case of concentrated loads the integral containing  $\mu$  can be split into ranges over which  $\mu$  varies continuously. When H has been found, M and the normal thrust P may be found from (1) as in the previous article, or graphically from the linear arch drawn by a funicular polygon with a pole distance proportional to H.

*Graphical Method.*—If the force scale is *p* pounds to 1 inch, the correct pole distance for drawing the linear arch is  $h = \frac{H}{p}$ , and if the linear scale is *q* inches to 1 inch, P' (Fig. 185) being a point on the linear arch or line of thrust—

$$\mu = P'Q \times p \cdot q \cdot h \text{ (Art. 58) and } y = q \cdot GQ$$

hence from (3), 
$$H = pl = \frac{\int \frac{P'Q \times GQ}{EI} ds \times p \cdot hq^2}{\int \frac{GQ^2}{EI} ds \times q^2}$$

therefore 
$$\frac{\int \frac{P'Q \times GQ}{EI} \cdot ds}{\int \frac{GQ^2}{EI} ds} = 1$$

If the diagram of bending moments  $\mu$  be drawn to *any* scale, the ordinates PQ being  $n$  times the true ordinates P'Q—

$$\frac{\int \frac{PQ \cdot GQ}{EI} \cdot ds}{\int \frac{GQ^2}{EI} \cdot ds} = n$$

To get the true ordinates P'Q of the linear arch, each ordinate such as PQ must be altered in the ratio 1 to  $n$  or multiplied by  $\frac{1}{n}$ , *i.e.* by—

$$\frac{\int \frac{GQ^2}{EI} ds}{\int \frac{PQ \cdot GQ}{EI} ds}$$

a ratio which can be found for any case graphically, by approximate summation after subdivision of the curve into a number of equal lengths.

EXAMPLE I.—A circular arched rib of radius equal to the span is hinged at each end and carries a uniform load  $w$  per unit length of span. Find the horizontal thrust and the maximum bending moment. Solve also the same case when the rib is hinged at the crown as well as at the ends.

Fig. 186 represents the centre line of the arch where—

$$l = R \quad \text{and} \quad \sin \alpha = \frac{l}{2R} = \frac{1}{2} \quad \alpha = \frac{\pi}{6} \quad \text{or} \quad 30^\circ \quad \cos \alpha = \frac{\sqrt{3}}{2}$$

$$ds = R \cdot d\theta \quad y = ED = R(\cos \theta - \cos \alpha)$$

$$x = \frac{l}{2} - R \sin \theta = R\left(\frac{1}{2} - \sin \theta\right) \quad \mu = \frac{w}{2}x(l-x) = \frac{wR^2}{2}\left(\frac{1}{4} - \sin^2 \theta\right)$$

Then from (4)—

$$H = \frac{\int_{\theta=-\alpha}^{\theta=\alpha} \mu y ds}{\int_{\theta=-\alpha}^{\theta=\alpha} y^2 ds} = \frac{2 \cdot \frac{w}{2} R^4 \int_0^\alpha \left(\frac{1}{4} - \sin^2 \theta\right) (\cos \theta - \cos \alpha) d\theta}{2 R^3 \int_0^\alpha (\cos \theta - \cos \alpha)^2 d\theta}$$

$$= \frac{wR}{4} \cdot \frac{\pi\sqrt{3} - 5}{5\pi - 9\sqrt{3}} = 0.923wR$$

From (1) the bending moment anywhere is—

$$M = \frac{wR^2}{2} \left( \frac{1}{4} - \sin^2 \theta \right) - 0.923wR^2 \left( \cos \theta - \frac{\sqrt{3}}{2} \right)$$

$$\frac{dM}{d\theta} = (-\sin \theta \cos \theta + 0.923 \sin \theta) wR^2$$

which vanishes for  $\theta = 0$  and  $\cos \theta = 0.923$ . Substituting these two values, at  $\theta = 0$ ,  $M = 0.00132wR^2$ , a bending moment producing decreased curvature at the crown. At  $\cos \theta = 0.923$ ,  $M = -0.00146wR^2$ , a bending moment producing increased curvature; the position of this bending moment is  $\theta = 22.6^\circ$ ,  $\sin \theta = 0.384$ ,  $x = 0.116l$ , *i.e.* it occurs at distances 0.116 of the span from the ends.

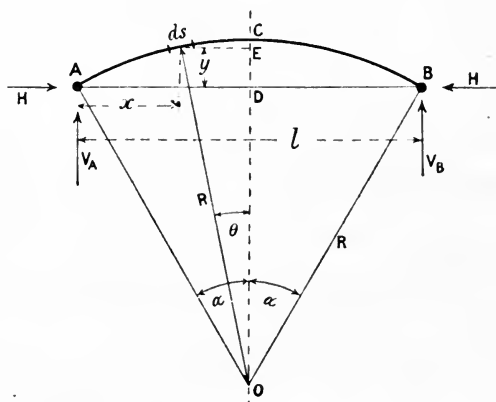

FIG. 186.

If the rib is hinged at C as well as at A and B, since the bending moment at C is zero—

$$H \times CD = \frac{1}{8}wl^2 = \frac{1}{8}wR^2 \quad \text{and} \quad CD = R \left( 1 - \frac{\sqrt{3}}{2} \right)$$

$$H = \frac{0.125wR}{0.134} = 0.934wR$$

Hence from (1)—

$$M = \frac{wR^2}{2} \left( \frac{1}{4} - \sin^2 \theta \right) - 0.934wR^2 \left( \cos \theta - \frac{\sqrt{3}}{2} \right)$$

$$\frac{dM}{d\theta} = -wR^2 \sin \theta \cos \theta + 0.934wR^2 \sin \theta$$

which vanishes for  $\theta = 0$  and  $\cos \theta = 0.934$ . The latter value gives the point of maximum bending moment,  $\sin \theta = 0.3573$ , and—

$$(\text{max.}) M = \frac{wR^2}{2} (0.25 - 0.1277) - 0.934wR^2 \times 0.068 = -0.0023wR^2$$

a bending moment producing increased curvature,  $0.3573$  of the span (horizontally) from the centre of the span.

EXAMPLE 2.—A circular arched rib of span  $l$  and radius  $R$  carries a single load  $W$  at a distance  $a$  from the centre of the span. Find the horizontal thrust if the rib is hinged (1) at the crown and ends, (2) at the ends only.

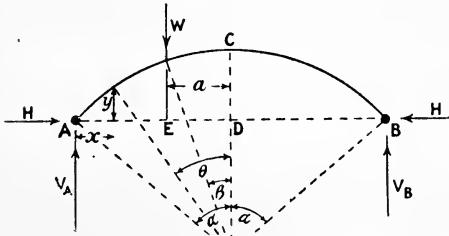

FIG. 187.

With the notation in Fig. 187—

$$\sin \alpha = \frac{l}{2R}$$

$$\sin \beta = \frac{a}{R}$$

$$V_A = \frac{2a + l}{2l} W$$

$$V_B = \frac{l - 2a}{2l} W$$

$$y = R(\cos \theta - \cos \alpha) \quad x = \frac{l}{2} - R \sin \theta \quad CD = R(1 - \cos \alpha) \quad ds = R \cdot d\theta$$

(1) Taking moments about C, of the forces on CB—

$$H \times R(1 - \cos \alpha) = \frac{l}{2} V_B$$

$$H = \frac{l - 2a}{4R(1 - \cos \alpha)} \cdot W$$

(2) From A to E  $\mu = \frac{l + 2a}{2l} \cdot Wx = W\left(\frac{l}{2} - R \sin \theta\right) \frac{l + 2a}{2l}$

from E to B  $\mu = \frac{l - 2a}{2l} W(l - x) = W \frac{l + 2a}{2l} \left(\frac{l}{2} + R \sin \theta\right)$

$$H = \frac{\int_{\theta = -\alpha}^{\theta = \alpha} \mu y ds}{\int_{\theta = -\alpha}^{\theta = \alpha} y^2 ds}$$

$$\begin{aligned} & W \frac{l + 2a}{2l} \int_{\beta}^{\alpha} \left(\frac{l}{2} - R \sin \theta\right) (\cos \theta - \cos \alpha) d\theta \\ & + W \frac{l - 2a}{2l} \int_{-\alpha}^{\beta} \left(\frac{l}{2} + R \sin \theta\right) (\cos \theta - \cos \alpha) d\theta \\ = & \frac{\hspace{10em}}{R \int_{-\alpha}^{\alpha} (\cos \theta - \cos \alpha)^2 d\theta} \end{aligned}$$

which may easily be found, the limits  $\alpha$  and  $\beta$  being as given above.

141. Temperature Stresses in Two-hinged Rib.—If an arched rib were free to take up any position it would expand, due to increase



of temperature, and remain of the same shape. But if the ends are hinged to fixed abutments the span cannot increase, and in consequence the rib exerts an outward thrust on the hinges, and the hinges exert an equal and opposite thrust on the rib; a fall in temperature would cause forces opposite to those called into play by an increase. In either case the horizontal reactions arising from temperature change produce a bending moment as well as a direct thrust or pull in the rib. The change in span arising from these bending moments and that arising from temperature change neutralise one another or have a sum zero.

Let  $\alpha$  be the coefficient of linear expansion (see Art. 39), and  $t$  be the *increase* of temperature of the rib; then the horizontal expansion, being prevented by the hinges, is—

$$\alpha t \cdot l$$

where  $l$  is the length of span. Hence if  $M$  is the bending moment produced at any section of the rib, the centroid of which is at a height  $y$  above the horizontal line joining the hinges, and  $ds$  is an element of length of the curved centre line of the rib, from Art. 134 (1)—

$$\alpha t l + \int \frac{M}{EI} \cdot y \cdot ds = 0 \dots \dots \dots (1)$$

and since  $M$  arises from the horizontal thrust  $H$ —

$$M = -Hy \dots \dots \dots (2)$$

producing increased curvature (see Art. 139); hence—

$$\alpha t l - H \int \frac{y^2}{EI} ds = 0$$

or

$$H = \frac{\alpha t l}{\int \frac{y^2}{EI} ds} \dots \dots \dots (3)$$

and if  $E$  and  $I$  are constant, this becomes—

$$H = \frac{EI \alpha t l}{\int y^2 ds} \dots \dots \dots (4)$$

the integrals being taken in either case over the whole span.

The bending moment anywhere,  $-H \cdot y$ , being proportional to  $y$ , the ordinates of the centre line of the rib measured from the horizontal line joining the hinge centres are proportional to the bending moment, thus giving a bending-moment diagram; the straight line joining the hinges is the line of thrust or "linear arch" for the temperature effects. The stresses at any section due to bending, and due to direct thrust or pull, may be calculated separately and added, the former being the more important. If  $h$  is the rise of the rib above the hinges at the highest point or crown, and  $d$  is the depth of the section, taken as

constant and symmetrical about a central axis, the maximum bending moment due to temperature change is—

$$H \cdot h = \frac{E I \alpha t l h}{\int y^2 ds}$$

and the resulting change of bending stress at outside edges of this section is—

$$f = \frac{H h}{I} \times \frac{d}{2} = \frac{E \alpha t l h d}{2 \int y^2 ds} \dots \dots \dots (5)$$

EXAMPLE.—A circular arched rib of radius equal to the span is hinged at each end. Find the horizontal thrust resulting from a rise of temperature of 50° F., the coefficient of expansion being 0.0000062 per degree Fahrenheit. If the depth of the rib is  $\frac{1}{40}$  of the span, and E = 13,000 tons per square inch, find the extreme change in the bending stresses.

As in Ex. 1, Art. 140, and Fig. 186—

$$l = R \quad \sin a = \frac{1}{2} \quad a = \frac{\pi}{6} \quad \cos a = \frac{\sqrt{3}}{2} \quad ds = -R d\theta$$

$$y = R \left( \cos \theta - \frac{\sqrt{3}}{2} \right)$$

$$\int_{\theta=a}^{\theta=-a} y^2 ds = 2 \int_0^a R^3 (\cos^2 \theta - \sqrt{3} \cos \theta + \frac{3}{4}) d\theta = R^3 \cdot \frac{5\pi - 9\sqrt{3}}{12} = 0.00996 R^3$$

hence, from (4), the horizontal thrust—

$$H = \frac{E I \alpha t R}{0.00996 R^3} = \frac{50 \times 0.0000062 E I}{0.00996 R^2} = 0.03112 \frac{E I}{R^2}$$

The bending moment at the crown is—

$$-H R \left( 1 - \frac{\sqrt{3}}{2} \right) = -0.03112 \times 0.134 \frac{E I}{R} = -0.00417 \frac{E I}{R}$$

hence the extreme change of bending stress is—

$$0.00417 \frac{E I}{R} \times \frac{R}{801} = 0.0000521 \times 13,000 = 0.677 \text{ ton per sq. inch}$$

142. **Arched Rib fixed at the Ends.**—The arched rib fixed or clamped in direction at both ends bears to the rib virtually hinged at each end much the same relation as that of the straight built-in beam to the beam simply supported at each end. The principles of Chap. VII. hold good for the built-in arched rib. In order to find the bending moment at any section X of such a rib (Fig. 188), it is necessary to know the fixing couples applied at the built-in ends and the horizontal

7  
D.C.O.

thrust. Then we may write, as in Arts. 85 to 88, allowing for the effect of horizontal thrust—

$$M = \mu + M_A + (M_B - M_A) \frac{x}{l} - Hy \quad (1)$$

where  $\mu$  is the bending moment on a straight horizontal freely supported beam carrying the same vertical loads,  $M_A$  and  $M_B$  are the fixing couples at the ends A and B respectively,  $H$  is the constant horizontal thrust, and  $y$  is the height of the rib at  $X$  above the supports A and B. Bending moments being reckoned positive if tending to *decrease convexity upwards* as in Art. 139, the fixing couples  $M_A$  and  $M_B$  will generally be negative quantities, instead of positive ones as in Chap. VII., where the opposite convention as to signs was used.

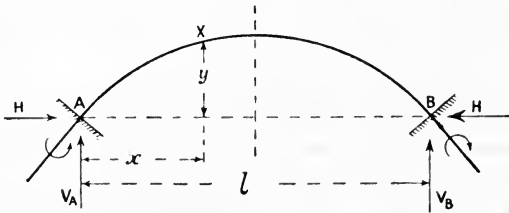

FIG. 188.

The three unknown quantities  $M_A$ ,  $M_B$ , and  $H$  may be found from the following three conditions:—

(1) The assumption that A and B remain fixed leads, as in Art. 140, from (1), Art. 134, to the equation—

$$\int \frac{My}{EI} \cdot ds = \int \frac{\mu y}{EI} ds + M_A \int \frac{y ds}{EI} + \frac{M_B - M_A}{l} \int \frac{xy ds}{EI} - H \int \frac{y^2}{EI} ds = 0 \quad (2)$$

the integrals being taken over the complete length of the curved centre line of the rib; if  $E$  and  $I$  are constant they may be omitted from each term.

(2) The assumption, as in Arts. 87 and 88, that the total bending or change from original direction over the whole length of arch is zero when the ends are firmly fixed gives—

$$\int \frac{M}{EI} ds = \int \frac{\mu}{EI} ds + M_A \int \frac{ds}{EI} + \frac{M_B - M_A}{l} \int \frac{x ds}{EI} - H \int \frac{y ds}{EI} = 0 \quad (3)$$

the integrals being over the whole length of the curve, and  $EI$  being omitted when constant.

(3) If the ends A and B remain at the same level, as in Arts. 87 and 88—

$$\int \frac{Mx}{EI} ds = \int \frac{\mu x}{EI} ds + M_A \int \frac{x ds}{EI} + \frac{M_B - M_A}{l} \int \frac{x^2 ds}{EI} - H \int \frac{xy}{EI} ds = 0 \quad (4)$$

the integrals being over the whole length of curve between A and B, and EI being omitted when constant.

The three equations (2), (3), and (4) are sufficient to determine the three unknown quantities  $M_A$ ,  $M_B$ , and H. If all the variables entering into the integrals can easily be expressed in terms of a single variable, ordinary methods of integration may be used. If not, some approximate form of summation by division of the arch AB into short lengths  $\delta s$ , or graphical methods such as are explained in Art. 88, may be used.

In the case of symmetrical loading,  $M_A = M_B$  and equation (4) becomes unnecessary; in that case equations (2) and (3) reduce to—

$$\int \frac{\mu y}{EI} \cdot ds + M_A \int \frac{y ds}{EI} - H \int \frac{y^2 ds}{EI} = 0 \quad \dots \dots (5)$$

$$\int \frac{\mu}{EI} ds + M_A \int \frac{ds}{EI} - H \int \frac{y ds}{EI} = 0 \quad \dots \dots (6)$$

which are still further simplified if E and I are constants.

An alternative plan would be to take as unknown quantities, say H,  $V_A$ , and  $M_A$ ; here, again, for symmetrical loading the unknown quantities reduce to two,  $V_A$  being then equal to half the load.

**143. Temperature Stresses in Fixed Rib.**—With the same notation as in Art. 141, for the direction AB (Fig. 188), in which expansion is prevented as for the two-hinged rib—

$$\int \frac{My}{EI} \cdot ds + atl = 0 \quad \dots \dots (1)$$

Also as in (3), Art. 142, 
$$\int \frac{M ds}{EI} = 0 \quad \dots \dots (2)$$

and as in (4), Art. 142, 
$$\int \frac{Mx}{EI} ds = 0 \quad \dots \dots (3)$$

Let H and V be the vertical and horizontal thrusts at either end of the span resulting from a temperature change of  $t$  degrees (V is equal and opposite at the two ends), and let  $M_A$  be the fixing couple at the supports due to the temperature change; then—

$$M = M_A + V \cdot x - H \cdot y \quad \dots \dots (4)$$

This value of M substituted in the three equations (1), (2), and (3), gives the necessary equations to find  $M_A$ , V, and H. The bending moment anywhere in the rib then follows from (4).

If the rib is symmetrical about a vertical axis through the middle of the span, V is zero, and the two equations (2) and (3) reduce to one, and equation (4) becomes—

$$M = M_A - Hy \quad \dots \dots (5)$$

which, being substituted in (1) and (2), gives—

$$M_A \int \frac{y}{EI} \cdot ds - H \int \frac{y^2}{EI} \cdot ds + atl = 0 \quad \dots \dots (6)$$

and

$$M_A \int \frac{ds}{EI} - H \int \frac{y}{EI} ds = 0 \dots \dots \dots (7)$$

from which  $M_A$  and  $H$  may be found.

The "line of thrust" in this case is a straight horizontal line the distance of which above  $AB$  (Fig. 188) is—

$$\frac{M_A}{H}$$

In the uncommon case of an unsymmetrical rib the line of thrust would be inclined to the line  $AB$ , passing at distances  $\frac{M_A}{T}$  and  $\frac{M_B}{T}$  respectively from  $A$  and  $B$  when  $T$  is the thrust the components of which are  $H$  and  $V$ , and  $M_B$  is the fixing moment at  $B$ , viz.  $M_A + V \cdot l$ .

EXAMPLE.—Solve the problem at the end of Art. 141 in the case of an arched rib rigidly fixed in direction at both ends. Find also the point of zero bending moment.

In this case—

$$\int_{\theta = -\frac{\pi}{6}}^{\theta = \frac{\pi}{6}} y ds = 2R^2 \int_0^{\frac{\pi}{3}} \left( \cos \theta - \frac{\sqrt{3}}{2} \right) d\theta = R^2 \left( 1 - \frac{\sqrt{3}\pi}{6} \right) = 0.0931R^2$$

$$\int_{\theta = -\frac{\pi}{6}}^{\theta = \frac{\pi}{6}} y^2 ds = 0.00996R^3 \text{ (see Art. 141)}$$

$$\int_{-\frac{\pi}{6}}^{\frac{\pi}{6}} ds = \frac{\pi}{3} R = 1.0472R$$

Substituting these values in (6) and (7)—

$$0.0931M_A \cdot R^2 - 0.00996R^3 H + 0.00031EIR = 0$$

$$1.0472M_A \cdot R - 0.09310R^2H = 0$$

$$M_A = \frac{0.09310}{1.0472}HR = 0.08890HR$$

hence  $H = 0.1845 \frac{EI}{R^2}$        $M_A = 0.0164 \frac{EI}{R}$

At the crown (Fig. 186)  $y = \left( 1 - \frac{\sqrt{3}}{2} \right) R = 0.134R$

and  $M_C = 0.0164 \frac{EI}{R} - 0.1845 \times 0.134 \frac{EI}{R} = -0.0083 \frac{EI}{R}$

The maximum bending moment is  $M_A$  at the supports, and at those sections the extreme change in bending stress is—

$$f = \frac{M_A \times d}{2I} = \frac{0.0164EI}{2RI} \times \frac{R}{40} = 0.000205 \times 13,000 \\ = 2.665 \text{ tons per square inch}$$

which is nearly four times the value for the similar hinged arch in Art. 141.

The points of zero bending moment occur when  $Hy = M_A$ .

$$y = \frac{M_A}{H} = 0.0889R = R \left( \cos \theta - \frac{\sqrt{3}}{2} \right) \\ \cos \theta = \frac{\sqrt{3}}{2} + 0.0889 = 0.9549 \quad \theta = 17.3^\circ$$

Distance from support  $= x = R \left( \frac{1}{2} - \sin \theta \right) = 0.2026R$  or  $0.2026$  of the span.

**144. Hanging Wires and Chains.**—The problem of the hanging wire or chain carrying vertical loads is closely related to that of the arched rib; it is also related as an extreme case to the very long tie-rod carrying lateral loads. We assume the length to be so great that the flexural rigidity is negligible, the load being supported entirely by the tension in the hanging wire. In all cases the horizontal component of the tension is necessarily constant; at a concentrated load the vertical component changes by the amount of that load. The problem of finding the shape and tensions of a chain suspended from given points, carrying isolated loads in given positions, may be treated graphically or analytically from the elementary principles of statics.<sup>1</sup> If the loading is continuous and easily expressed as a function of the length of chain or span, an analytical solution is the simplest.

**145. Uniformly Distributed Loads.**—When the load is uniformly distributed over the span, a case approximately realised in some suspension-bridge cables and in telegraph and trolley wires

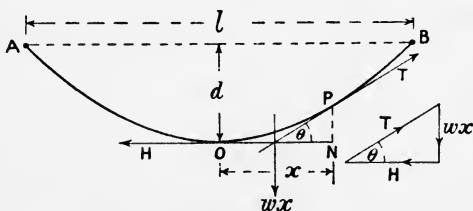

FIG. 189.

which are tightly stretched and loaded by their own weight, the form of the curve in which the wire hangs is parabolic.

Let  $w$  be the load per unit length of horizontal span,  $T$  the tension at any point  $P$  (Fig. 189), and  $H$  the constant horizontal component tension. Take the origin at the lowest point  $O$ , and the axes of  $x$  and  $y$  horizontal and vertical

<sup>1</sup> Some simple examples will be found in the Author's "Mechanics for Engineers," Art. 166.

respectively. Then the length of wire or chain OP is kept in equilibrium by three forces, viz. T, H, and its weight  $w x$ , where  $x = ON$ , the horizontal projection of OP. Then from the triangle of forces, or moments about P—

$$\frac{H}{wx} = \frac{x}{2y} \quad \text{or} \quad y = \frac{wx^2}{2H} \dots \dots \dots (1)$$

which is the equation to a parabola with its vertex at the origin O. Also—

$$H = \frac{wx^2}{2y} = \frac{wl^2}{8d} \dots \dots \dots (2)$$

where  $l$  is the span AB and  $d$  is the total dip. The tension anywhere is—

$$T = \sqrt{H^2 + w^2x^2} \dots \dots \dots (3)$$

which at the points of support A or B reaches the value—

$$T = \sqrt{H^2 + \frac{w^2l^2}{4}} = \frac{wl^2}{8d} \sqrt{1 + \frac{16d^2}{l^2}} \dots \dots (4)$$

which does not greatly differ from H if  $\frac{d}{l}$  is a small fraction. If the points of suspension are at levels differing by  $h$  (Fig. 190), and  $x_1$  is the horizontal distance of the vertex of the parabola from the lower support B, and  $d$  is the dip below that support, from (1)—

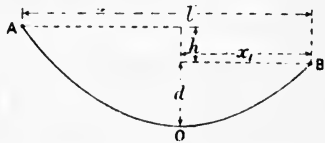

FIG. 190.

$$H = \frac{wx^2}{2y} = \frac{wx_1^2}{2d} = \frac{w(l - x_1)^2}{2(d + h)} \quad (5)$$

from which  $x_1$  may be found in terms of  $d$ ,  $l$ , and  $h$ . The intensity of tensile stress in the wire, Fig. 189, is—

$$p = \frac{T}{A}$$

where A is the area of cross-section, and neglecting the small variation in T—

$$p = \frac{H}{A} = \frac{wl^2}{8Ad} \dots \dots \dots (6)$$

Note that for a hanging wire loaded only by its own weight,  $p$  is independent of the area of section A, since  $w$  is proportional to A. Also that if  $w$  is in pounds per foot length,  $l$  and  $d$  in feet,  $p$  is in pounds per square inch if A is in square inches.

The length of such a very flat parabolic arc measured from the origin is approximately<sup>1</sup>—

$$x + \frac{2}{3} \frac{y^2}{x}$$

hence the total length of wire  $s$  is—

$$s = l + \frac{8}{3} \frac{d^2}{l} . . . . . (7)$$

A change of temperature affects the length of such a hanging wire in two ways: the linear contraction or expansion alters the dip; a change in dip corresponds to a change in tension, but owing to elastic stretch or contraction a change in tension corresponds to a change in length independent of temperature changes. The change in dip and in tension resulting from a change in temperature is thus jointly dependent on the change of temperature, coefficient of linear expansion, and the elastic properties of the material.

Let  $s_0$  be the initial length of the wire,  $d_0$  the initial dip,  $p_0$  the initial intensity of tensile stress,  $t$  the rise in temperature,  $a$  the coefficient of linear expansion,  $w$  the weight per unit length,  $A$  the area of cross-section, and  $E$  the direct or stretch modulus of elasticity of the material;  $\frac{w}{A}$  is then the weight per unit volume—

$$s_0 = l + \frac{8}{3} \frac{d_0^2}{l} \quad p_0 = \frac{wl^2}{8Ad_0}$$

After the change of temperature—

$$s = s_0 \left( 1 + at + \frac{p - p_0}{E} \right) = l + \frac{8}{3} \frac{d^2}{l} . . . . . (8)$$

and substituting for  $p$  from (6)—

$$s_0 \left\{ 1 + at + \left( \frac{wl^2}{8Ad} - p_0 \right) \frac{1}{E} \right\} = l + \frac{8}{3} \frac{d^2}{l} . . . . . (9)$$

If  $d_0, l, w, A,$  and  $E$  are known,  $s_0$  and  $p_0$  are known from (7) and (6) and (9) is then a cubic equation for  $d$ ;  $p$  may be obtained from  $d$

<sup>1</sup> If  $y = cx^2,$   $\frac{dy}{dx} = 2cx$

$$\frac{ds}{dx} = \sqrt{1 + \left(\frac{dy}{dx}\right)^2} = 1 + \frac{1}{2} \left(\frac{dy}{dx}\right)^2$$

approximately if  $\frac{dy}{dx}$  is small;

$$ds = (1 + 2c^2x^2)dx$$

$$s = x + \frac{2}{3}c^2x^3 = x + \frac{2}{3} \frac{y^2}{x}$$



from the relation (6). Reducing (9) by substituting for  $s_0$  and  $p_0$  and dividing by  $s_0$ —

$$1 + at + \frac{wl^2}{8EA} \cdot \frac{d_0 - d}{d_0 d} = 1 + \frac{8}{3} \cdot \frac{d^2 - d_0^2}{l^2} \text{ approximately (10)}$$

$$(d - d_0) \left\{ \frac{wl^2}{8AEdd_0} + \frac{8(d + d_0)}{3l^2} \right\} - at = 0 \dots \dots (11)$$

which is the cubic equation for  $d$  in terms of the initial dip, the span, change of temperature, and constants of the material. The change of temperature which would cause any assigned change in dip or tension is easily calculated from (10). In many cases where the hanging wire is not very tight, for atmospheric temperature changes, the change in dip is almost entirely due to the direct thermal elongation  $at$ , and the third term on the left side of equation (10) is negligible, the equation reducing to—

$$d^2 = d_0^2 + \frac{3}{8}atl^2 \quad d = \sqrt{d_0^2 + \frac{3}{8}atl^2}$$

EXAMPLE 1.—A steel wire has a dip of 3 feet on a span of 100 feet. Find the change of dip and of tension due to a fall in temperature of  $50^\circ$ . Weight of steel 480 pounds per cubic foot; coefficient of expansion  $62 \times 10^{-7}$ .  $E = 30 \times 10^6$  pounds per square inch.

The length of wire is  $s_0 = 100 + \frac{8}{3} \times \frac{9}{100} = 100.24$  feet  
 Shortening due to fall of temperature, }  
 neglecting elasticity }  $= 50 \times 62 \times 10^{-7}$   
 $= 31 \times 10^{-5}$  of the length  
 $s = 100.24(1 - 0.00031)$   
 $= 100.209$

$$100 + \frac{8}{3} \frac{d^2}{100} = 100.209 \quad d^2 = \frac{3}{8} \times 20.9 = 7.8375$$

$d = 2.80$  feet; a decrease of 0.20 foot

The weight of 1 foot length of wire 1 square inch in section =  $\frac{480}{144}$   
 $= \frac{10}{3}$  lb.

Initially  $p_0 = \frac{1}{8} \cdot \frac{10}{3} \times \frac{100 \times 100}{3} = 1389$  pounds per square inch

hence  $p = \frac{3}{2.8} \times 1389 = 1488$  " "

$p - p_0 = 99$  " "

Elastic extension  $\frac{p - p_0}{E} = \frac{99}{30 \times 10^6} = 33 \times 10^{-7}$

which is negligible in comparison with  $31 \times 10^{-5}$ , the shortening calculated above due to thermal change, thus justifying the approximation made. If a more exact (cubic) equation for  $d$  be formed, as in (10), the result is substantially the same.

EXAMPLE 2.—Take the initial dip in Ex. 1 to be 1 foot.

$$s_0 = 100 + \frac{8}{3} \times \frac{1}{100} = 100.0267 \text{ feet}$$

$$p_0 = \frac{1}{8} \cdot \frac{10}{8} \cdot 10,000 = 4167 \text{ pounds per square inch}$$

A reduction of 0.00031 of  $s_0$  would leave a length less than 100 feet; the approximation made in Ex. 1 is not valid in this case. Substituting the numerical data in (10)—

$$- 0.00031 + \frac{1}{8} \cdot \frac{10}{3} \cdot \frac{10,000(1-d)}{30 \times 10^6 d} = \frac{8d^2 - 1}{3 \cdot 10,000}$$

which reduces to  $d^3 + 0.683d - 0.521 = 0$

from which by trial  $d = 0.537$  foot = 6.44 inches, a decrease of 5.56 inches. The stress being proportional to  $\frac{1}{d}$

$$p = \frac{4167}{0.537} = 7761 \text{ pounds per square inch}$$

an increase of 3594 pounds per square inch.

146. **Common Catenary.**—When a cord or wire of uniform cross-section hangs freely from two points of support, the curve formed is a catenary; the parabolic form assumed in the previous article is a very close approximation when the dip is small. With the same notation as in Art. 145, if  $w$  is the weight per unit length of arc (instead of per unit length of span), considering the equilibrium of a length  $AP = s$  (Fig. 191), measured from the lowest point A, taking an origin vertically below A—

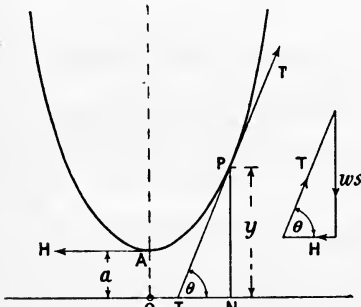

FIG. 191.

$$ws = H \tan \theta \quad \text{or} \quad s = \frac{H}{w} \tan \theta$$

$$= a \tan \theta \dots \dots (1)$$

where  $a = \frac{H}{w}$  denotes the length of wire or cord which, hanging vertically, would have a tension H at its upper end due to its own weight;

$$\tan \theta = \frac{dy}{dx} \quad \cos \theta = \frac{dx}{ds} \quad \sin \theta = \frac{dy}{ds}$$

and from (1),  $\frac{ds}{d\theta} = a \sec^2 \theta$

hence  $\frac{dy}{d\theta}$  or  $\frac{dy}{ds} \cdot \frac{ds}{d\theta} = \sin \theta \cdot a \sec^2 \theta$  or  $a \frac{\sin \theta}{\cos^2 \theta}$

and integrating,  $y = a \int \frac{\sin \theta d\theta}{\cos^2 \theta} = a \sec \theta \dots \dots (2)$

if  $y = a$  when  $\theta = 0$ ; i.e. the origin O is a distance  $a$  below A.

Also  $\frac{dx}{d\theta} = \frac{dx}{ds} \cdot \frac{ds}{d\theta} = \cos \theta \cdot a \sec^2 \theta = a \sec \theta \dots (3)$

and integrating—

$$x = a \int \sec \theta d\theta = a \log_e \tan \left( \frac{\pi}{4} + \frac{\theta}{2} \right) = a \log_e (\sec \theta + \tan \theta) \quad (4)$$

or,  $e^{\frac{x}{a}} = \sec \theta + \tan \theta \dots (5)$

and taking the reciprocals,  $e^{-\frac{x}{a}} = \sec \theta - \tan \theta \dots (6)$

hence, adding—

$$\frac{1}{2}(e^{\frac{x}{a}} + e^{-\frac{x}{a}}) = \sec \theta = \frac{y}{a} \text{ from (3), i.e.—}$$

$$\cosh \frac{x}{a} = \frac{y}{a} \text{ or } y = a \cosh \frac{x}{a} \dots (7)$$

which is the equation to the catenary.

Expanding the equation (7)—

$$y = a \left( 1 + \frac{x^2}{2a^2} + \frac{x^4}{12a^4} +, \text{ etc.} \right) = a + \frac{x^2}{2a} + \frac{a}{12} \times \left( \frac{x}{a} \right)^4 +, \text{ etc.}$$

and for small values of  $x$ , neglecting the third and subsequent terms—

$$y = a + \frac{x^2}{2a} = a + \frac{wx^2}{2H}$$

representing a parabola, being the same equation as (1), Art. 145, with the origin a distance  $a$  below the vertex A.

The tension at any point P is, from (2)—

$$T = H \sec \theta = w \cdot y$$

equal to that at the upper end of a length  $y$ , hanging vertically.

The length of curve  $s$  measured from the vertex A is—

$$\begin{aligned} s &= \int \frac{ds}{dx} dx = \int \sqrt{1 + \left(\frac{dy}{dx}\right)^2} dx = \int \sqrt{1 + \sinh^2 \frac{x}{a}} dx \\ &= \int \cosh \frac{x}{a} dx = a \sinh \frac{x}{a} \end{aligned}$$

the constant of integration being zero, since  $s = 0$  for  $x = 0$ .

EXAMPLES XII.

1. A rectangular bar 2 inches wide and 3 inches deep is curved in a plane parallel to its depth, the mean radius of curvature being 4 inches. If the bar is subject to a bending moment of 15 ton-inches tending to reduce its curvature, find the maximum intensities of tensile and compressive bending stress.

2. A round bar of steel  $1\frac{1}{2}$  inch diameter is curved to a mean radius of  $1\frac{1}{4}$  inch. Find the extreme intensities of tensile and compressive stress when the bar is subject to a bending moment of 4000 lb.-inches tending to bend the bar to a smaller radius.

3. The principal section of a hook is a symmetrical trapezium 3 inches deep, the width at the inside of the hook being 3 inches and at the outside 1 inch. The centre of curvature of both inside and outside of the hook at this section is in the plane of the section and  $2\frac{3}{4}$  inches from the inside of it, and the load line passes  $2\frac{1}{4}$  inches from the inner side of the section. Estimate the safe load for this hook in order that the greatest tensile stress shall not exceed 7 tons per square inch.

4. The figure shows the principal section of a hook, the centres  $O_3$  and  $O_4$  of the rounded corners being on the lines  $O_1E$  and  $O_1D$ . The centre of curvature of the inside and outside of the hook is in the line  $AB$  produced and  $2\frac{1}{4}$  inches from  $B$ , and the load line passes through the centre of curva-

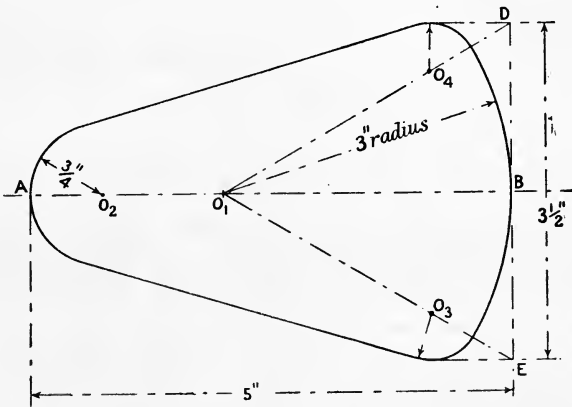

Figure for problem No. 4.

ture. Estimate the greatest intensities of tensile and compressive stress on the section if the hook carries a load of 10 tons.

5. A ring is made of round steel 1 inch diameter, and the mean diameter of the ring is 5 inches. Estimate the greatest intensities of tensile and compressive stress resulting from a pull of 2000 pounds on the ring.

6. Estimate the increase in the diameter in the line of pull of the ring in problem No. 5, and the contraction of the diameter perpendicular to the line of pull. Take  $E = 30 \times 10^6$  pounds per square inch.

7. The links of a chain are made of 1-inch round steel and have semi-circular ends, the mean radius of which is  $1\frac{1}{4}$  inch; the ends are connected by straight pieces 1 inch long. Estimate the greatest intensities of tensile and compressive stress in the link when the chain sustains a load of 2000 pounds.

8. A flat spiral spring of rectangular section is 1 inch broad and  $\frac{1}{10}$  inch thick and 20 feet long. What twisting moment may it exert on a central spindle if the bending stress is not to exceed 100,000 pounds per square inch? How many complete turns may be given to the spring when it is run down, and how much work is then stored in it? What pull does the spring exert on the fastening if its outer end is at a radius of 1.75 inches?

9. A symmetrical three-hinged arch rib is of circular form, has a span of 50 feet and a rise of 10 feet. If the uniformly distributed load is 1 ton per foot of span, find the horizontal thrust and the bending moment at  $\frac{1}{2}$  span (horizontally) from one end.

10. A parabolic arched rib, hinged at the springings and crown, has a span of 50 feet and a rise of 10 feet; if the load varies uniformly with the horizontal distance from the crown from  $\frac{1}{2}$  ton per foot of span at the crown to 1 ton per foot run at the springings, find the horizontal thrust and the bending moment at  $\frac{1}{2}$  span. What is the normal thrust and the shearing force 5 feet from one of the abutments?

11. Find the horizontal thrust for the arch in problem No. 9 if it is hinged at the ends only.

12. A parabolic two-hinged arched rib has a span of 40 feet and a rise of 8 feet, and carries a load of 10 tons at the crown. The moment of inertia of the cross-section of the rib is everywhere proportional to the secant of the angle of slope of the rib. Find the horizontal thrust and the bending moment at the crown. (Hint,  $I = I_0 \frac{ds}{dx}$  where  $I_0$  is the moment of inertia at the crown.)

13. Find the maximum intensity of bending stress in a circular arched rib 50 feet span and 10 feet rise, hinged at each end, due to a rise in temperature of  $60^\circ$  F., the constant depth of the rib being 12 inches. Coefficient of expansion  $\frac{3}{8} \times 10^{-6}$ .  $E = 12,500$  tons per square inch.

14. A semicircular arched rib of span  $l$ , and fixed at both ends, carries a load  $W$  at the crown. Find the bending moment, normal thrust, and shearing force at the ends and crown.

15. A piece of steel 1 inch square is bent into a semicircle of 20 inches mean radius, and both ends are firmly clamped. Find the maximum bending stress resulting from a change in temperature of  $100^\circ$  F. in the steel. What is the angular distance of the points of zero-bending moment from the crown of the semicircle? (Coefficient of expansion  $62 \times 10^{-7}$ .  $E = 30 \times 10^6$  pounds per square inch.)

16. A trolley wire  $\frac{1}{8}$  square inch in section has a span of 120 feet, a sag of 10 inches, and weighs 115 pounds per 100 yards. Find the intensity of tension in the wire.

17. With a maximum sag of 1 foot and maximum tension of 7000 pounds per square inch, what is the maximum span for a copper wire, the weight of copper being 0.32 pound per cubic inch?

18. On a span of 60 feet a steel wire has a sag of 2 feet 3 inches. Find the increase in dip due to a rise of temperature of  $50^\circ$  F. (Coefficient of expansion  $67 \times 10^{-7}$ , weight of steel 480 pounds per cubic foot.)

19. A steel wire spans a distance of 100 feet and the dip at  $90^\circ$  F. is 1 foot. What is the intensity of tensile stress in the wire? At what temperature will the dip be decreased to 6 inches, and what is then the stress in the wire?  $E = 30 \times 10^6$  pounds per square inch. Steel 480 pounds per cubic foot.

20. What would be the dip and the stress in the wire in problem No. 19, when the temperature falls to  $20^\circ$  F.?

21. A uniform wire 200 feet long and weighing  $w$  pounds per foot of length is suspended from two points 100 feet apart and on the same level. Find the dip, the tension at the lowest point, and the tension at the points of support.

## CHAPTER XIII.

### *FLAT PLATES.*

147. Flat plates supported at their edges and loaded by forces perpendicular to their flat faces undergo flexure, and an investigation of their strength is therefore somewhat similar to that of straight beams, with the important difference that the bending is not all in or parallel to one plane, but in every plane perpendicular to the flat faces.

The circular plate symmetrically loaded, from the symmetry about every diameter, of the reaction or supporting force at its edge, is the simplest case to consider; it is also in itself perhaps the most important practical case of an unstayed flat plate. We shall examine the stresses and strains in a circular plate by the simple Bernoulli-Euler theory of bending, making such modifications as are necessary to allow for flexure in other than a single plane. As in the case of straight beams, it will be necessary to distinguish between cases where the plate is firmly clamped or *encastré* at its perimeter, and where it is simply supported there. By the stresses obtained by this theory we shall be able to test the results of a simple approximate investigation, from which the stresses in plates of various shapes may be calculated subject to a numerical coefficient.

148. **Stress and Strain in a Circular Plate.**—The stresses and strains calculated in the following articles have been given by Grashof, and widely quoted. Grashof took the maximum strain as the measure of elastic strength (see Art. 25), and very frequently the values of—

$$E \times (\text{maximum strain})$$

given by him are incorrectly quoted as being the maximum stress; the maximum stress is of greater magnitude. As we neglect any principal stress perpendicular to the face of the plate, the measure of the strength according to the maximum shear stress or stress difference theory (Art. 25) is the greatest principal stress.

In the case of beams it is assumed that cross-sectional dimensions are small compared to the length, and so in calculating the bending stress in circular plates we shall assume that the thickness is small in comparison with the diameter. It will also be assumed that the loading is symmetrical, and consequently the stress and strain will be symmetrical about an axis perpendicular to the plate and through its

centre. It will be convenient to speak of the plate as horizontal, and the loads as vertical. We shall assume that straight lines in the plate originally vertical become after strain straight lines inclined to the vertical axis. By symmetry all straight lines originally vertical and at the same radius must evidently suffer the same change of inclination, and must all cut the vertical axis in the same point, a circular cylindrical surface with axis COV (Fig. 192) being transformed into a conical surface with the same axis.

Let  $x$  be the distance before straining of any point P (Fig. 192) in the plate from the central axis perpendicular to the plate; let  $y$  be its distance from the middle plane of the plate, reckoned positive downwards, and let  $\theta$  be the inclination to the vertical of lines originally vertical at a radius  $x$ . Let the suffix  $z$  denote the circumferential direction where  $x$  indicates the radial direction for the variable strains and stresses,  $e_z$  and  $e_x$  being the circumferential and radial

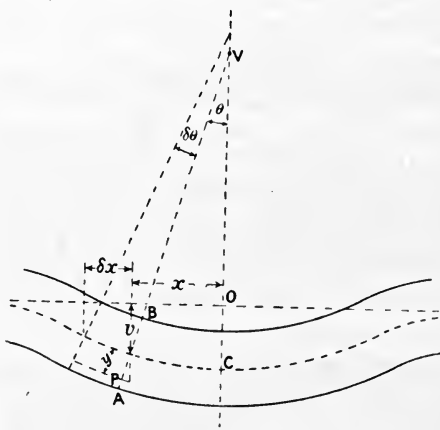

FIG. 192.

strains,  $p_x$  and  $p_z$  the circumferential and radial intensities of stress respectively, reckoned positive when tensile. We shall neglect the shear stresses perpendicular to  $p_x$  and  $p_y$  in thin plates just as we did the shear stresses and strains in *long* beams.

After straining, the concave side of the plate will evidently be in compression, and the convex side will be in tension both radially and circumferentially; the middle plane will evidently be unstrained or a *neutral* plane. The radius at P will increase to—

$$x + \theta y$$

hence the circumferential strain at a depth  $y$  from the neutral plane is—

$$e_z = \frac{2\pi(x + \theta y) - 2\pi x}{2\pi x} = \frac{\theta y}{x} \dots \dots \dots (1)$$

which may be written  $\frac{y}{\rho}$  where  $\rho = \frac{x}{\theta}$  is the radius of curvature of the originally horizontal surface through P at a radius  $x$  in a plane containing BV and perpendicular to the plane of BV and OV (compare Art. 61). Also, if at a radius  $x + \delta x$  the inclination to the vertical of lines originally vertical is  $\theta + \delta\theta$ , at a depth  $y$  the distance  $\delta x$  is increased to—

$$\delta x + y\delta\theta$$

and the radial strain is—

$$e_x = y \cdot \frac{d\theta}{dx} \dots \dots \dots (2)$$

which may be written  $\frac{y}{\rho}$  where  $\rho' = \frac{dx}{d\theta}$ , the radius of curvature of the plate in the meridian plane containing BV and CV (compare Art. 61).

Hence from Art. 19, the principal stress in the direction parallel to the axis OV being zero, circumferentially—

$$e_z = \frac{\theta y}{x} = \frac{1}{E} \left( p_z - \frac{p_x}{m} \right) \dots \dots \dots (3)$$

and radially,

$$e_x = y \frac{d\theta}{dx} = \frac{1}{E} \left( p_x - \frac{p_z}{m} \right) \dots \dots \dots (4)$$

where  $\frac{1}{m}$  is Poisson's ratio; and solving the simultaneous equations (3) and (4)—

$$p_z = \frac{Em}{m^2 - 1} \cdot y \left( m \frac{\theta}{x} + \frac{d\theta}{dx} \right) \dots \dots \dots (5)$$

$$p_x = \frac{Em}{m^2 - 1} y \left( \frac{\theta}{x} + m \frac{d\theta}{dx} \right) \dots \dots \dots (6)$$

from which it is evident that both the radial and circumferential-stress intensities on the section AB are proportional to the distance  $y$  from the neutral surface, and may be represented, as in Fig. 75, for the intensity of bending stress in a beam.

Consider now the equilibrium of an element of the plate (Fig. 193) included between radii  $x$  and  $x + \delta x$ , and between two vertical meridian planes inclined at a very small angle  $\delta\phi$  to each other. The upper part of Fig. 193 represents a horizontal section taken below the neutral surface, and consequently the stresses  $p_x$  and  $p_z$  appear as *tensile* stresses; the portion *above* the neutral surface where  $y$  is negative will have

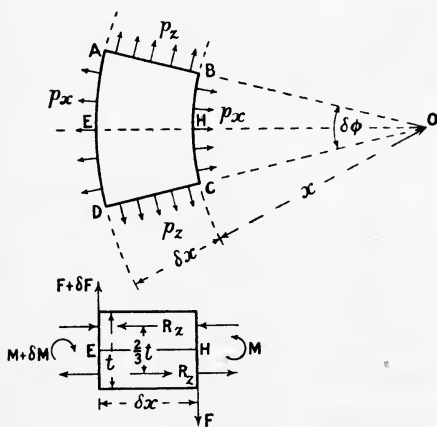

FIG. 193.

radial and circumferential *compressive* forces acting upon it due to the stress across the boundaries of the element.

*Resultant of Circumferential Stress on Element.*—The forces  $p_x$  on the faces AB and CD (Fig. 193) are inclined at an angle  $\left(\frac{\pi}{2} - \frac{\delta\phi}{2}\right)$  to the middle radius OHE. On any element of area  $\delta a$  of either face the force is  $p_x \cdot \delta a$ ; resolving this parallel and perpendicular to EH, the forces perpendicular to EH have a zero resultant, since components on every pair of corresponding elements of AB and CD are equal and



opposite. The forces parallel to EH from two corresponding elements  $\delta a$ , one in AB and the other in CD, are to the first order of small quantities—

$$2p_z \cdot \delta a \cdot \sin \frac{\delta\phi}{2} = p_z \cdot \delta a \cdot \delta\phi$$

$p_z$  being of opposite sign on the opposite sides of the neutral surface, the total force parallel to EH on the element resulting from the circumferential stress is zero. The total moment of the couple formed by the above elementary forces, about an axis in the neutral plane and perpendicular to the radius OH, is—

$$\delta\phi \Sigma(y \cdot p_z \cdot \delta a)$$

the summation being taken over one of the faces AB or CD; and substituting the value of  $p_z$  from (5) the total moment is—

$$\delta\phi \frac{Em}{m^2 - 1} \left( m \frac{\theta}{x} + \frac{d\theta}{dx} \right) \Sigma(y^2 \cdot \delta a) \dots \dots \dots (7)$$

If  $t$  is the thickness of the plate,  $\Sigma(y^2 \cdot \delta a)$ , the moment of inertia of the rectangular face AB is  $\frac{1}{12} \cdot \delta x \cdot t^3$ , and the moment of the circumferential stress about an axis perpendicular to EH is—

$$\frac{1}{12} \cdot \delta x \cdot \delta\phi \cdot t^3 \frac{Em}{m^2 - 1} \left( m \frac{\theta}{x} + \frac{d\theta}{dx} \right) \dots \dots \dots (8)$$

which might also be expressed in the form—

$$R_z \times \frac{2}{3}t$$

where  $R_z = \delta\phi \Sigma(p_z \cdot \delta a)$ , the total force in the direction EO on one side of the neutral plane, resulting from the circumferential stress on AB and DC, and  $\frac{2}{3}t$  is the arm of the couple or distance between the centre of pull and centre of pressure (see Fig. 193). If  $\theta$  is positive, *i.e.* the vertex V of the conical surface (Fig. 192) is *above* the plate, and  $\frac{d\theta}{dx}$  is positive, *i.e.* the plate is convex downwards, the amount (8) is contra-clockwise viewed from the side DC of the element.

*Resultant of Radial Stress on Element.*—The force on an element  $\delta a$  of the face BC resolved parallel to EH, to the first order of small quantities is—

$$p_x \cdot \delta a$$

The total force on the face BC due to radial stress is zero, the resultant being a couple formed by the opposite forces on opposite sides of the neutral plane, the moment of which is—

$$\Sigma(p_x \cdot y \cdot \delta a)$$

the summation being over the face BC, of area  $t \cdot x \cdot \delta\phi$ ; substituting the value of  $p_x$  from (6) the moment is—

$$M = \frac{Em}{m^2 - 1} \left( \frac{\theta}{x} + m \frac{d\theta}{dx} \right) \Sigma(y^2 \delta a) = \frac{x \cdot \delta\phi \cdot t^3}{12} \frac{Em}{m^2 - 1} \left( \frac{\theta}{x} + m \frac{d\theta}{dx} \right) \quad (9)$$

Similarly, the moment  $M + \delta M$  on the face AD might be written in terms of  $x + \delta x$  and  $\theta + \delta\theta$ . The difference  $\delta M$  between  $M + \delta M$  and  $M$  is  $\frac{dM}{dx} \cdot \delta x$ , which, differentiating (9), is—

$$\frac{1}{12} \frac{\delta x \cdot \delta \phi \cdot t^3 \cdot E \cdot m}{m^2 - 1} \left( \frac{d\theta}{dx} + m \frac{d\theta}{dx} + mx \frac{d^2\theta}{dx^2} \right) \dots (10)$$

If, as before,  $\theta$  and  $\frac{d\theta}{dx}$  are positive, the moment  $M$  in (9) will be contra-clockwise in accordance with the moment (8). If in addition  $\frac{dM}{dx}$  is positive, *i.e.* the moment  $M$  increases with increase of  $x$ , the clockwise moment  $M + \delta M$  on AD is in excess of the contra-clockwise moment on BC, and (10) is a clockwise moment resulting from the radial stress on the element considered and is opposed to the couple (8).

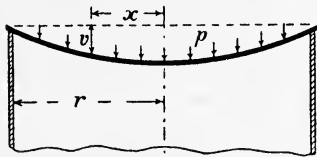

The resultant of the two couples (8) and (10) must be balanced by the external forces, including the loads and reactions. We now proceed to particular cases.

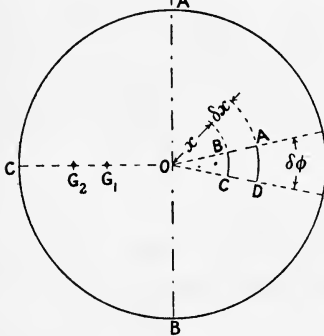

FIG. 194.

**149. Circular Plate freely supported at its Circumference, under Uniform Pressure on its Face.**—Let  $p$  be the uniform pressure per unit of area of the plate, and let  $r$  be the radius and  $t$  the thickness of the plate (Fig. 194). The external vertical force on a circular portion of radius  $x$ , and concentric with the whole plate, is  $p \cdot \pi x^2$ . Hence the vertical cylindrical surface which divides this circular portion from the rest of the plate has a total vertical shearing force  $p\pi x^2$  upon

it, and a face such as BC, Figs. 193 and 194, will have upon it a vertical shearing force—

$$F = p\pi x^2 \times \frac{\delta\phi}{2\pi} = \frac{p x^2}{2} \cdot \delta\phi \dots (1)$$

The shearing force  $F + \delta F$  on the vertical face AD will similarly be—

$$\frac{p}{2}(x + \delta x)^2 \delta\phi$$

The moment of the external forces about an axis in the neutral plane and perpendicular to EH (Fig. 193), neglecting quantities of the second

order of smallness, such as the product of the vertical load on ABCD, and the distance of its centre from E, will be—

$$F \cdot \delta x = \frac{p x^2}{2} \cdot \delta \phi \cdot \delta x \cdot \dots \cdot \dots \cdot \dots \quad (2)$$

a clockwise moment as viewed from the side DC.

The conditions of equilibrium as applied to the element ABCD require that the moment (2), together with the moments (8) and (10) of Art. 148, shall have an algebraic sum zero, hence the contra-clockwise moment is—

$$\frac{1}{12} \frac{E m t^3}{m^2 - 1} \cdot \delta x \cdot \delta \phi \left\{ \left( m \frac{\theta}{x} + \frac{d\theta}{dx} \right) - \left( m x \frac{d^2 \theta}{dx^2} + \frac{d\theta}{dx} + m \frac{d\theta}{dx} \right) \right\} - \frac{p x^2}{2} \cdot \delta \phi \cdot \delta x = 0$$

or, dividing by  $\frac{E m t^3}{12(m^2 - 1)} \cdot \delta x \cdot \delta \phi$

$$\text{and reducing: } x \frac{d^2 \theta}{dx^2} + \frac{d\theta}{dx} - \frac{\theta}{x} = - \frac{6(m^2 - 1)p}{E m^2 t^3} x^2 \cdot \dots \cdot \dots \quad (3)$$

which is of the same form as equation (10), Art. 126.

The complete solution found, as in Art. 126, is—

$$\frac{\theta}{x} = A + \frac{B}{x^2} - \frac{3}{4} \frac{(m^2 - 1)p}{E m^2 t^3} \cdot x^2 \cdot \dots \cdot \dots \quad (4)$$

$$\frac{d\theta}{dx} = A - \frac{B}{x^2} - \frac{3}{4} \frac{(m^2 - 1)p}{E m^2 t^3} \cdot x^2 \cdot \dots \cdot \dots \quad (5)$$

The constants of integration, A and B, may be found from the conditions at the centre and circumference. Evidently at the centre, where  $x = 0$ ,  $\theta = 0$ , hence from (4)  $B = 0$ . At the edge  $x = r$ ,  $p_x = 0$ , hence, substituting the values (4) and (5) in (6) of Art. 148—

$$0 = \frac{\theta}{x} + m \frac{d\theta}{dx} = A(m + 1) - (3m + 1) \frac{3}{4} \frac{(m^2 - 1)p}{E m^2 t^3} \cdot r^2$$

$$A = \frac{3m + 1}{m + 1} \cdot \frac{3}{4} \frac{(m^2 - 1)p r^2}{E m^2 t^3}$$

substituting, (4) and (5) become—

$$\frac{\theta}{x} = \frac{3}{4} \frac{(m^2 - 1)p}{E m^2 t^3} \left( \frac{3m + 1}{m + 1} r^2 - x^2 \right) \cdot \dots \cdot \dots \quad (6)$$

$$\frac{d\theta}{dx} = \frac{3}{4} \frac{(m^2 - 1)p}{E m^2 t^3} \left( \frac{3m + 1}{m + 1} r^2 - 3x^2 \right) \cdot \dots \cdot \dots \quad (7)$$

hence from (5), Art. 148, the intensity of circumferential stress is—

$$p_z = \frac{3}{4} \frac{p y}{m t^3} \{ (3m + 1) r^2 - (m + 3) x^2 \} \cdot \dots \cdot \dots \quad (8)$$

and from (6), Art. 148, the intensity of radial stress is—

$$p_x = \frac{3}{4} \frac{p y}{m t^3} (3m + 1)(r^2 - x^2) \dots \dots \dots (9)$$

Both these intensities of stress reach their maximum values at the centre  $x = 0$  on either side of the plate  $y = \pm \frac{t}{2}$ , and their value is—

$$(\text{max.}) p_x = (\text{max.}) p_z = \pm \frac{3 p r^2}{8 t^2} \cdot \frac{3m + 1}{m} \dots \dots (10)$$

$$\text{If } m = 3, (\text{max.}) p_x = (\text{max.}) p_z = \frac{5}{4} p \frac{r^2}{t^2} \dots \dots \dots (11)$$

$$\text{If } m = 4, (\text{max.}) p_x = (\text{max.}) p_z = \frac{39}{32} p \frac{r^2}{t^2} \dots \dots \dots (12)$$

If  $r$  and  $t$  are in the same units, say inches, the intensities of stress  $p_x$  and  $p_z$  are in the same units as  $p$ , generally pounds per square inch.

The strains (1) and (2), Art. 148, substituting the values (6) and (7), are—

$$e_z = y \cdot \frac{\theta}{x} = \frac{3}{4} \frac{(m^2 - 1) p y}{E m^2 t^3} \left( \frac{3m + 1}{m + 1} r^2 - x^2 \right) \dots \dots (13)$$

$$e_x = y \cdot \frac{d\theta}{dx} = \frac{3}{4} \frac{(m^2 - 1) p y}{E m^2 t^3} \left( \frac{3m + 1}{m + 1} r^2 - 3x^2 \right) \dots \dots (14)$$

each of which reaches the same maximum value at  $x = 0, y = \pm \frac{t}{2}$ , when—

$$(\text{max.}) E \cdot e_z = (\text{max.}) E e_z = \pm \frac{3}{8} \frac{(m - 1)(3m + 1)}{m^2} \cdot p \cdot \frac{r^2}{t^2} \dots \dots (15)$$

$$\text{If } m = 3, (\text{max.}) E \cdot e_x = (\text{max.}) E \cdot e_z = \frac{5}{8} p \cdot \frac{r^2}{t^2} \dots \dots (16)$$

$$\text{If } m = 4, (\text{max.}) E e_x = (\text{max.}) E \cdot e_z = \frac{117}{128} \cdot p \cdot \frac{r^2}{t^2} \dots \dots (17)$$

which, according to the “maximum strain” theory of elastic strength (Art. 25), is the measure of elastic strength. It may be noted that at the centre of a circular plate symmetrically loaded and supported  $p_x = p_z$ ; hence, by Art. 19, since we neglect stress perpendicular to the faces—

$$E \cdot e_z = E \cdot e_x = \frac{m - 1}{m} \cdot p_z = \frac{m - 1}{m} \cdot p_x$$

Further illustrations occur in Arts. 150, 151, 152, and 153.

*Shear Stress in the Plate.*—Following the method adopted for straight beams (Art. 71), we may roughly estimate the vertical shear stress; from (1) its average intensity at a radius  $x$  is—

$$F \div t \cdot x \cdot \delta\phi \quad \text{or} \quad p \pi x^2 \div 2 \pi x t = \frac{p x}{2 t}$$

and if we take it to vary over the thickness of plate in the same way as over the depth of a beam of rectangular section (Fig. 98 and Art. 71) its maximum intensity, which occurs at the middle surface  $y = 0$ , is  $\frac{3}{4}$  times the mean, or—

$$\frac{3}{4} \cdot \frac{px}{t}$$

This has its greatest value—

$$\frac{3}{4} \cdot \frac{pr}{t} \dots \dots \dots (18)$$

at the circumference, where  $x = r$ . This magnitude is only comparable with (10) if  $\frac{t}{r}$  is not small. We are neglecting in our theory stress intensities of the magnitude (18), and also the vertical direct compressive stress, varying from  $p$  on the upper face of the plate to zero on the lower face. The complementary shear stresses of magnitude (18) involve two equal and opposite principal stresses of the same magnitude, and this must give a maximum principal strain  $e'$ , such that, from Art. 19—

$$E \cdot e' = \frac{m + 1}{m} \cdot \frac{3}{4} \frac{pr}{t}$$

*Form of Deflection.*—Let  $v$  be the deflection at a radius  $x$  of the neutral or middle surface of the plate from its original position (see Figs. 192 and 194). Then the tangent of slope to the horizontal of a line in which a meridian plane intersects the neutral surface is  $-\frac{dv}{dx} = \tan \theta$ . The deflections and slopes being supposed small as in a beam, we may take the angle  $\theta$  equal to its tangent, and from (6)—

$$-\frac{dv}{dx} = \theta = \frac{3}{4} \frac{(m^2 - 1)p}{Em^2t^3} \left( \frac{3m + 1}{m + 1} r^2x - x^3 \right) \dots \dots (19)$$

$$v = -\frac{3}{4} \frac{(m^2 - 1)p}{Em^2t^3} \left( \frac{3m + 1}{m + 1} \frac{r^2x^2}{2} - \frac{x^4}{4} + C \right) \dots \dots (20)$$

and since  $v = 0$  for  $x = r$ —

$$C = -\frac{r^4}{4} \cdot \frac{5m + 1}{m + 1}$$

and 
$$v = -\frac{3}{8} \frac{(m^2 - 1)p}{Em^2t^3} \left( \frac{3m + 1}{m + 1} r^2x^2 - \frac{x^4}{2} - \frac{5m + 1}{m + 1} \frac{r^4}{2} \right) \dots \dots (21)$$

which reaches its greatest magnitude at the centre  $x = 0$ , viz.—

$$\frac{3}{16} \frac{(m - 1)(5m + 1) \cdot pr^4}{m^2Et^3} \dots \dots \dots (22)$$

and if  $m = 3$ , this becomes—

$$\frac{2}{3} \frac{pr^4}{Et^3} \dots \dots \dots (23)$$

150. Circular Plate clamped at its Circumference and under Uniform Pressure on its Face.—The

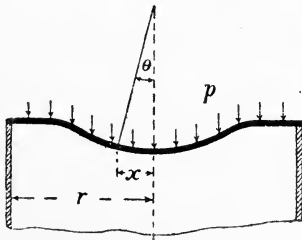

FIG. 195.

horizontal circular plate firmly clamped in a horizontal direction (Fig. 195) bears to the plate freely supported at its circumference a relation analogous to that of the beam built in at its ends to the beam freely supported at its ends. The work of Art. 149 holds good so far as (5).

For  $\theta = 0$   $x = 0$ , hence  $B = 0$ . The condition which determines  $A$  is at the circumference  $\theta = 0$  for  $x = r$ , hence from (4), Art. 149—

$$A = \frac{3}{4} \frac{(m^2 - 1)p}{Em^2t^3} r^2 \dots \dots \dots (1)$$

and substituting in (4) and (5), Art. 149—

$$\frac{\theta}{x} = \frac{3}{4} \frac{(m^2 - 1)p}{Em^2t^3} (r^2 - x^2) \dots \dots \dots (2)$$

$$\frac{d\theta}{dx} = \frac{3}{4} \frac{(m^2 - 1)p}{Em^2t^3} (r^2 - 3x^2) \dots \dots \dots (3)$$

hence, substituting in (5), Art. 148—

$$p_z = \frac{3}{4} \frac{py}{mt^3} \{(m + 1)r^2 - (m + 3)x^2\} \dots \dots \dots (4)$$

and substituting in (6), Art. 148—

$$p_x = \frac{3}{4} \frac{py}{mt^3} \{(m + 1)r^2 - (3m + 1)x^2\} \dots \dots \dots (5)$$

Both these stress intensities reach extreme values of opposite signs, on the faces of the plate, at the centre  $x = 0$  and the circumference  $x = r$ . The greatest intensity of bending stress in the plate is that of the radial stress at the circumference. Putting  $x = r$  in (5)—

$$p_x = -\frac{3}{2} \frac{pyr^2}{t^3} \dots \dots \dots (6)$$

and for  $y = \pm \frac{t}{2}$  this becomes—

$$(\text{max.}) p_x = \mp \frac{3}{4} \frac{r^2}{t^2} p \dots \dots \dots (7)$$

At the centre  $x = 0$ , and  $y = \pm \frac{t}{2}$ , the radial and circumferential stresses are—

$$p_x = p_z = \frac{3}{8} \frac{m + 1}{m} \cdot \frac{r^2}{t^2} p \dots \dots \dots (8)$$

The greatest strains are evidently the radial strains at  $x = r$ , and from (3) the values at  $x = r, y = \pm \frac{t}{2}$ ,

$$(\text{max.}) \epsilon_x = \pm y \frac{d\theta}{dx} = \mp \frac{3}{4} \frac{m^2 - 1}{Em^2} \cdot \frac{r^2}{t^2} p \dots (9)$$

At  $x = 0$  the signs are reversed and the magnitudes are halved, and  $\epsilon_x$  has the same value as  $\epsilon_z$ .

If  $m = 3$      $(\text{max.}) E\epsilon_x = \frac{2}{3} \frac{r^2}{t^2} \cdot p \dots (10)$

If  $m = 4$      $(\text{max.}) E \cdot \epsilon_x = \frac{45}{64} \cdot \frac{r^2}{t^2} \cdot p \dots (11)$

Putting the slope equal to its tangent, as in the previous article, and integrating—

$$-\frac{dv}{dx} = \theta = \frac{3}{4} \frac{(m^2 - 1)p}{Em^2 t^3} (r^2 x - x^3) \dots (12)$$

the deflection—

$$v = -\frac{3(m^2 - 1)p}{4 Em^2 t^3} \left( \frac{r^2 x^2}{2} - \frac{x^4}{4} + C \right) \dots (13)$$

and since  $v = 0$  for  $x = r$ —

$$C = -\frac{r^4}{4}$$

$$v = \frac{3}{16} \frac{(m^2 - 1)p}{Em^2 t^3} (r^2 - x^2)^2 \dots (14)$$

which reaches its greatest magnitude at the centre for  $x = 0$ , viz.—

$$\frac{3}{16} \frac{(m^2 - 1)}{Em^2 t^3} \cdot p r^4$$

and if  $m = 3$  this becomes—

$$\frac{1}{6} \frac{p r^4}{E t^3} \dots (15)$$

which is  $\frac{1}{4}$  of the value (23), Art. 149, for the freely supported plate. The intensity of vertical shearing stress may be estimated as for the freely supported plate.

EXAMPLE 1.—A cylinder 16 inches diameter has a flat end 1 inch thick. Find the greatest intensity of stress in the end if the pressure in the cylinder is 120 pounds per square inch, if the end is taken as (a) freely supported, (b) firmly clamped, at its circumference. Find in each case what intensity of simple direct stress would produce the same maximum strains. Take Poisson's ratio as  $\frac{1}{3}$ .

(a) From (11), Art. 149—

$$(\text{max.}) p_x = \frac{5}{4} \times 120 \times 64 = 9600 \text{ pounds per square inch}$$

From (16), Art. 149—

$$(\text{max.}) Ee_x = \frac{5}{6} \times 120 \times 64 = 6400 \quad \text{,,} \quad \text{,,} \quad \text{,,}$$

(b) From (7), Art. 150—

$$(\text{max.}) p_x = \frac{3}{4} \times 120 \times 64 = 5760 \quad \text{,,} \quad \text{,,} \quad \text{,,}$$

From (10), Art. 150—

$$(\text{max.}) Ee_x = \frac{3}{8} \times 120 \times 64 = 5120 \quad \text{,,} \quad \text{,,} \quad \text{,,}$$

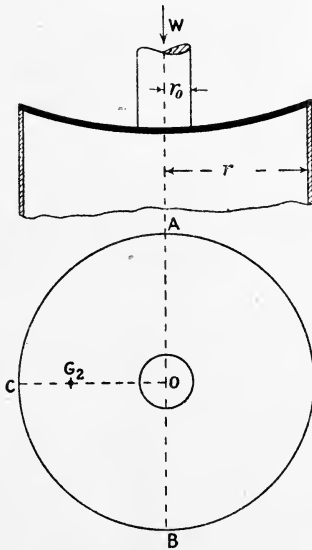

FIG. 196.

151. **Circular Plate freely supported at its Circumference and loaded at its Centre.**—If we take the load as concentrated at a point at the centre of the plate, we should find the stresses and strains at the centre of the plate infinite if the material be assumed perfectly elastic. The central load will be taken as uniformly distributed over a small circle of radius  $r_0$  concentric with the plate of radius  $r$  (Fig. 196). It will be necessary to treat separately the two regions into which the plate is thus divided. If  $W$  is the total load, the inner or loaded portion of the plate carries a uniform load  $p$  per unit area where

$$p = \frac{W}{\pi r_0^2}$$

The solution of equation (3) of Art. 149 therefore becomes—

$$\frac{\theta}{x} = A + \frac{B}{x^2} - \frac{3(m^2 - 1)W}{4 E m^2 t^3 \pi r_0^2} \cdot x^2 \dots \dots (1)$$

$$\frac{d\theta}{dx} = A - \frac{B}{x^2} - \frac{9(m^2 - 1)W}{4 E m^2 t^3 \pi r_0^2} \cdot x^2 \dots \dots (2)$$

For the outer portion of the plate the moment of the external force on an element ABCD (Fig. 193) is—

$$F \times \delta x = \frac{p r_0^2}{2} \cdot \delta \phi \cdot \delta x \text{ instead of } \frac{p x^2}{2} \cdot \delta \phi \cdot \delta x$$

and the equation (3) of Art. 149,  $p$  being equal to  $\frac{W}{\pi r_0^2}$ , becomes—

$$x \frac{d^2 \theta}{dx^2} + \frac{d\theta}{dx} - \frac{\theta}{x} = - \frac{6(m^2 - 1)W}{\pi E m^2 t^3} = \text{constant} \dots (3)$$



the complementary function is as before, and the particular integral is—

$$\theta = -\frac{3(m^2 - 1)W}{\pi E m^2 t^3} \cdot x \log_e x \dots \dots (4)$$

The complete solution may therefore be written—

$$\frac{\theta}{x} = C + \frac{D}{x^2} - \frac{3(m^2 - 1)W}{\pi E m^2 t^3} \log_e x \dots \dots (5)$$

$$\frac{d\theta}{dx} = C - \frac{D}{x^2} - \frac{3(m^2 - 1)W}{\pi E m^2 t^3} (\log_e x + 1) \dots \dots (6)$$

The four constants A, B, C, and D may be found from the four following conditions, which give four simultaneous simple equations:—

(1) The slope  $\theta = 0$  for  $x = 0$  in (1), hence  $B = 0$ .

(2) The slope  $\theta$  at  $x = r_0$  is the same for equations (1) and (5).

(3) The curvature  $\frac{d\theta}{dx}$  at  $x = r_0$  is the same for equations (2) and (6).

These three conditions hold good whether the plate is clamped or free. For the free plate the remaining condition is—

(4) The intensity of stress  $p_x = 0$  for  $x = r$ , hence by (6), Art. 148—

$$\frac{\theta}{x} + m \frac{d\theta}{dx} = 0 \text{ for } x = r$$

Solving the three simple equations for A, C, and D from conditions (2), (3), and (4)—

$$A = \frac{3(m^2 - 1)W}{\pi E m^2 t^3} \left( \frac{m}{m + 1} + \log_e \frac{r}{r_0} - \frac{m - 1}{m + 1} \frac{r_0^2}{4r^2} \right) \dots \dots (7)$$

$$C = \frac{3(m^2 - 1)W}{\pi E m^2 t^3} \left( \frac{m}{m + 1} + \log_e r - \frac{m - 1}{m + 1} \frac{r_0^2}{4r^2} \right) \dots \dots (8)$$

$$D = -\frac{3(m^2 - 1)W r_0^2}{4 \pi E m^2 t^3} \dots \dots \dots (9)$$

By substituting these values (and  $B = 0$ ) in (1), (2), (5), and (6), and using the relations (1), (2), (5), and (6) of Art. 148, the strains and stresses in any part of the plate may be found. It will be sufficient to examine their greatest values, which occur at the centre.

*Stresses.*—When  $x = 0$  and  $y = \pm \frac{t}{2}$ , where  $t$  is the thickness of the plate, remembering that tensile stress and strain have been chosen as positive—

$$\begin{aligned} (\max.) p_x &= (\max.) \hat{p}_x = \frac{E m y}{m^2 - 1} (m + 1) A \\ &= \pm \frac{3(m + 1)W}{2 \pi m t^2} \left( \frac{m}{m + 1} + \log_e \frac{r}{r_0} - \frac{m - 1}{m + 1} \frac{r_0^2}{4r^2} \right) \quad (10) \end{aligned}$$

which reduces to the form (10), Art. 149, if  $r_0 = r$ . If  $m = 3$ —

$$(\text{max.}) p_z = (\text{max.}) p_x = \frac{W}{\pi t^2} \left( \frac{3}{2} + 2 \log_e \frac{r}{r_0} - \frac{1}{4} \frac{r_0^2}{r^2} \right). \quad (11)$$

the last term of (10) or (11) being negligible if  $\frac{r_0}{r}$  is small. Note that as  $r_0$  approaches zero the term  $\log \frac{r}{r_0}$  becomes very great; such an approximate theory as the present should not be pushed to such limits; local plastic yielding at the place of application of the load will modify the assumed conditions of elasticity. The neglected vertical compressive stress of intensity  $\frac{W}{\pi r_0^2}$  under the load also approaches infinity as  $r_0$  approaches zero.

*Shear Stress.*—The greatest vertical shear stress will be at the radius  $x = r_0$ , where its mean intensity will be  $\frac{W}{2\pi r_0 t}$  and its maximum about 1.5 times this value. Unless  $r_0$  is much less than  $t$  the greatest value of this expression is much less than (11).

*Strains.*—The quantity  $E \times$  greatest principal strain, which, according to the "greatest strain theory" (Art. 25), is the measure of elastic strength, for  $x = 0, y = \frac{t}{2}$  is—

$$\begin{aligned} (\text{max.}) E \cdot \epsilon_x &= (\text{max.}) E \epsilon_x = E y \frac{\theta}{x} \quad \text{or} \quad E y \frac{d\theta}{dx} = E A y \\ &= \frac{3(m^2 - 1)W}{2\pi m^2 t^2} \left( \frac{m}{m + 1} + \log_e \frac{r}{r_0} - \frac{m - 1}{m + 1} \frac{r_0^2}{4r^2} \right). \quad (12) \end{aligned}$$

which reduces to form (15), Art. 149, when  $r_0 = r$ . And for  $m = 3$ —

$$(\text{max.}) E \cdot \epsilon = \frac{W}{\pi t^2} \left( 1 + \frac{4}{3} \log_e \frac{r}{r_0} - \frac{1}{6} \frac{r_0^2}{r^2} \right) \quad \dots \quad (13)$$

the last term of (12) and (13) being negligible when  $\frac{r_0}{r}$  is small.

*Deflection.*—The deflection anywhere on the plate may be found by integrating the value  $\frac{dv}{dx}$  or  $\theta$  from (5) for the outer portion, and determining the constant of integration from the condition  $v = 0$  for  $x = r$ . The condition for the inner portion is that  $v$  as found from equation (1) must be the same as that found from equation (5) at  $x = r_0$ . If  $r_0$  is small compared to  $r$ , it will be sufficient to find the deflection of the outer portion for  $x = r_0$ , that at the centre being very little greater—

$$-\frac{dv}{dx} = \theta = Cx + \frac{D}{x} - \frac{3(m^2 - 1)W}{\pi E m^2 t^3} \cdot x \log_e x \quad \dots \quad (14)$$

Substituting for C and D, and finding the constant of integration so that

$v = 0$  for  $x = r$ , and then rejecting all terms in which  $r_0^2$  is a factor, for  $x = r_0$ —

$$v = \frac{3(m-1)(3m+1)Wr^2}{4\pi Em^2 t^3} \text{ (approximately) . . . (15)}$$

and if  $m = 3$  this gives the deflection—

$$\frac{5}{3\pi} \frac{Wr^2}{Et^3} \text{ . . . . . (16)}$$

or about 2.5 times the deflection (see (23), Art. 149) caused by the same load uniformly spread over the plate.

**152. Circular Plate clamped at its Circumference and loaded at its Centre.**—The investigation of this case is similar to that for the freely supported plate in the previous article, except that the fourth condition for the determination of the constants of the solutions (1), (2), (5), and (6) is that  $\theta = 0$  for  $x = r$ . Solving the simple equations for A, C, and D—

$$A = \frac{3(m^2 - 1)W}{\pi Em^2 t^3} \left( \log_e \frac{r}{r_0} + \frac{r_0^2}{4r^2} \right) \text{ . . . . . (1)}$$

$$C = \frac{3(m^2 - 1)W}{\pi Em^2 t^3} \left( \log_e r + \frac{r_0^2}{4r^2} \right) \text{ . . . . . (2)}$$

$$D = -\frac{3}{4} \frac{(m^2 - 1)Wr_0^2}{\pi Em^2 t^3} \text{ . . . . . (3)}$$

From these values (and B = 0), and the relations (1), (2), (5), and (6) of Art. 151 with (1), (2), (5), and (6) of Art. 148, the strains and stresses everywhere in the plate may be found. We shall examine them for the centre and circumference, the tensile values being reckoned positive.

*Stresses.*—When  $x = 0$  and  $y = \pm \frac{t}{2}$ —

$$p_x = p_z = \frac{Emy}{m^2 - 1} (m + 1) \cdot A = \frac{3(m + 1)W}{2\pi m t^2} \left( \log_e \frac{r}{r_0} + \frac{r_0^2}{4r^2} \right) \text{ . . . (4)}$$

the last term being negligible if  $\frac{r_0}{r}$  is small, and the magnitude reducing to the form (8), Art. 150, if  $r_0 = r$ . If  $m = 3$ , (4) becomes—

$$p_x = p_z = \frac{W}{\pi t^2} \left( 2 \log_e \frac{r}{r_0} + \frac{r_0^2}{2r^2} \right) \text{ . . . . . (5)}$$

which is always less than (11), Art. 151, for the freely supported plate. When  $x = r$ , using (6), Art. 148, and (5) and (6), Art. 151, with the constants of the present article—

$$p_x = \frac{Emy}{m^2 - 1} \left[ (m + 1)C - (m - 1) \frac{D}{r^2} - \frac{3(m^2 - 1)W}{\pi Em^2 t^3} \left\{ (m + 1) \log_e r + m \right\} \right]$$

and when  $y = \pm \frac{t}{2}$ , inserting the values of C and D—

$$p_x = \mp \frac{3}{2} \frac{W}{\pi t^2} \left( 1 - \frac{r_0^2}{2r^2} \right) \quad \text{or} \quad \frac{W}{\pi t^2} \left( \frac{3}{2} - \frac{3r_0^2}{4r^2} \right) \dots \dots (6)$$

which reduces to the form (7), Art. 150, if  $r_0 = r$ .

It remains to examine the relative magnitudes of (5) and (6).

$$p_x \text{ at } x = 0 \text{ exceeds } p_x \text{ at } x = r$$

$$2 \log_e \frac{r}{r_0} + \frac{r_0^2}{2r^2} \text{ exceeds } \frac{3}{2} - \frac{3}{4} \cdot \frac{r_0^2}{r^2}$$

*i.e.* if  $\log_e \frac{r}{r_0}$  exceeds  $\frac{3}{4} - \frac{5}{8} \left( \frac{r_0}{r} \right)^2$

which is satisfied if  $\frac{r}{r_0}$  exceeds 1.7 approximately, *i.e.* the intensity of stress at the centre is the greatest stress in the plate if the diameter is more than 1.7 times the diameter of the area on which the load is applied.

*Strains.*— At the centre  $x = 0$ —

$$E \cdot e_x = E e_z = E \cdot y \cdot A = \frac{3(m^2 - 1)Wy}{\pi m^2 t^2} \left( \log_e \frac{r}{r_0} + \frac{r_0^2}{4r^2} \right)$$

and for  $y = \pm \frac{t}{2}$  and  $x = 0$ —

$$E \cdot e_0 = \pm \frac{3(m^2 - 1)W}{2\pi m^2 t^2} \left( \log \frac{r}{r_0} + \frac{r_0^2}{4r^2} \right) \dots \dots (7)$$

the last term being negligible if  $\frac{r_0}{r}$  is small. For  $m = 3$ —

$$E \cdot e_0 = \frac{W}{\pi t^2} \left( \frac{4}{3} \log \frac{r}{r_0} + \frac{1}{3} \frac{r_0^2}{r^2} \right) \dots \dots (8)$$

At the circumference, for  $x = r$  and  $y = \pm \frac{t}{2}$ , using the above values of C and D—

$$E e_x = E \cdot y \cdot \frac{d\theta}{dx} = \mp \frac{3(m^2 - 1)W}{2\pi m^2 t^2} \left( 1 - \frac{r_0^2}{2r^2} \right) \dots \dots (9)$$

which agrees with (9), Art. 150, when  $r_0 = r$ . And if  $m = 3$ —

$$E \cdot e_x = \frac{W}{\pi t^2} \left( \frac{4}{3} - \frac{2}{3} \frac{r_0^2}{r^2} \right) \dots \dots (10)$$

The value of  $E e_x$  at the centre exceeds the value at the circumference (for all values of  $m$ ) if

$$\log_e \frac{r}{r_0} + \frac{r_0^2}{4r^2} \text{ exceeds } 1 - \frac{r_0^2}{2r^2}$$

*i.e.* if  $\log_e \frac{r}{r_0}$  exceeds  $1 - \frac{3}{4} \frac{r_0^2}{r^2}$

which is satisfied if  $\frac{r}{r_0}$  exceeds 2.4 approximately, *i.e.* the strain at the centre of the plate is the greatest strain in the plate if the diameter of the plate is more than 2.4 times the diameter of the area on which the load is applied.

The vertical shearing stress will be similar to that in a freely supported plate.

*Deflection.*—As in the previous article, it will be sufficient to examine the greatest deflection when  $\frac{r_0}{r}$  is small. Putting the above values of C and D in (14), Art. 151, finding the constant of integration under the condition that  $v = 0$  for  $x = r$ , and then rejecting all terms having  $r_0^2$  as a factor, we find for  $x = r_0$ —

$$v = \frac{3(m^2 - 1)W}{\pi E m^2 t^3} \cdot \frac{r^2}{4} \dots \dots \dots (11)$$

and if  $m = 3$  this gives—

$$v = \frac{2}{3\pi} \cdot \frac{W r^2}{E t^3}$$

which is  $\frac{2}{5}$  of the deflection (16), Art. 151, for the freely supported plate.

**153. Circular Plate under Uniform Pressure and supported at its Centre.**

—This case (Fig. 197) involves work closely resembling previous cases, and may be dealt with very briefly. The support will be taken to be a uniform pressure on a circular area of radius  $r_0$ , concentric with the plate of radius  $r$ . The effective bending pressure on the inner part will be—

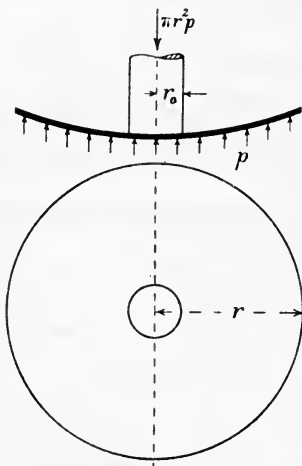

FIG. 197.

$$p \left( \frac{r^2}{r_0^2} - 1 \right) = p \frac{r^2 - r_0^2}{r_0^2}$$

hence, for the inner portion as in Art. 149—

$$x \frac{d^2\theta}{dx^2} + \frac{d\theta}{dx} - \frac{\theta}{x} = - \frac{6(m^2 - 1)(r^2 - r_0^2)p}{E m^2 t^3 r_0^2} x^2 \dots \dots \dots (1)$$

$$\frac{\theta}{x} = A + \frac{B}{x^2} - \frac{3(m^2 - 1)(r^2 - r_0^2)p}{4 E m^2 t^3 r_0^2} x^2 \dots \dots (2)$$

$$\frac{d\theta}{dx} = A - \frac{B}{x^2} - \frac{9(m^2 - 1)(r^2 - r_0^2)p}{4 E m^2 t^3 r_0^2} x^2 \dots \dots (3)$$

and since  $\theta = 0$  for  $x = 0$ ,  $B = 0$ . (If the plate were clamped to its support so that  $\theta = 0$  for  $x = r_0$ , the result would differ but little from

the present case if  $r_0$  is very small.) For the outer portion, in place of (2), Art. 149, we should have—

$$F = \frac{\rho}{2} \cdot \delta\phi(r^2 - x^2)$$

and the equation becomes—

$$x \frac{d^2\theta}{dx^2} + \frac{d\theta}{dx} - \frac{\theta}{x} = - \frac{6(m^2 - 1)\rho}{Em^2t^3} \cdot (r^2 - x^2) \dots (4)$$

and the particular integral follows the results of Arts. 149 and 151, the solution being—

$$\frac{\theta}{x} = C + \frac{D}{x^2} - \frac{3(m^2 - 1)\rho}{Em^2t^3} \left( r^2 \log_e x - \frac{x^2}{4} \right) \dots (5)$$

$$\frac{d\theta}{dx} = C - \frac{D}{x^2} - \frac{3(m^2 - 1)\rho}{Em^2t^3} \left\{ r^2 (\log_e x + 1) - \frac{3x^2}{4} \right\} \dots (6)$$

The three simple equations to find A, C, and D follow from the facts that the values of  $\theta$  from (2) and (5) must be the same for  $x = r_0$ ; the value  $\frac{d\theta}{dx}$  from (3) and (6) must be the same for  $x = r_0$ , and since

$$p_x = 0 \text{ for } x = r, \quad \frac{\theta}{x} + m \frac{d\theta}{dx} = 0 \text{ for } x = r.$$

Solving these equations, we find—

$$A = \frac{3(m^2 - 1)\rho}{Em^2t^3} \left\{ r^2 \log_e \frac{r}{r_0} + \frac{1}{4} \frac{m - 1}{m + 1} (r^2 - r_0^2) \right\} \dots (7)$$

$$C = \frac{3(m^2 - 1)\rho}{Em^2t^3} \left\{ r^2 \log_e r + \frac{1}{4} \frac{m - 1}{m + 1} (r^2 - r_0^2) \right\} \dots (8)$$

$$D = - \frac{3}{4} \frac{(m^2 - 1)\rho r^2 r_0^2}{Em^2t^3} \dots (9)$$

From these values the stress and strain anywhere may be written by use of the relations in Art. 148.

*Stress.*—At the centre  $x = 0$  and  $y = \pm \frac{t}{2}$ :

$$\begin{aligned} (\text{max.}) p_x &= (\text{max.}) p_x = \frac{Emy}{m^2 - 1} \cdot (m + 1)A \\ &= \pm \frac{3\rho r^2}{2mt^2} \left\{ (m + 1) \log_e \frac{r}{r_0} + \frac{1}{4}(m - 1) \left( 1 - \frac{r_0^2}{r^2} \right) \right\} \dots (10) \end{aligned}$$

which vanishes for  $r_0 = r$ , and, if  $m = 3$ , gives—

$$(\text{max.}) p_x = \pm \rho \cdot \frac{r^2}{t^2} \left\{ 2 \log_e \frac{r}{r_0} + \frac{1}{4} \left( 1 - \frac{r_0^2}{r^2} \right) \right\} \dots (11)$$

the term  $\frac{r_0^2}{r^2}$  being negligible if  $\frac{r_0}{r}$  is small. Compare this with (11), Art. 151, and with (5), Art. 152.

*Strain.*—At  $x = 0$  and  $y = \pm \frac{t}{2}$ —

$$\begin{aligned} (\text{max.}) E \cdot e_z &= (\text{max.}) E \cdot e_x = E \cdot A \cdot y \\ &= \pm \frac{3(m^2 - 1)\rho r^2}{2m^2 t^2} \left\{ \log_e \frac{r}{r_0} + \frac{1}{4} \frac{m - 1}{m + 1} \left( 1 - \frac{r_0^2}{r^2} \right) \right\}. \quad (12) \end{aligned}$$

which vanishes for  $r_0 = r$ , and, if  $m = 3$ , gives—

$$(\text{max.}) E \cdot e = \pm \rho \frac{r^2}{t^2} \left\{ \frac{4}{3} \log_e \frac{r}{r_0} + \frac{1}{4} \left( 1 - \frac{r_0^2}{r^2} \right) \right\}. \quad (13)$$

the term  $\frac{r_0^2}{r^2}$  being negligible if  $\frac{r_0}{r}$  is small. Compare this with (13), Art. 151, and (8), Art. 152.

*Deflection.*—Finding the central deflection as in the two previous articles, when  $\frac{r_0}{r}$  is small—

$$(\text{max.}) v = \frac{3(m - 1)(7m + 3)}{16m^2} \cdot \frac{\rho r^4}{Et^3} \dots \dots (14)$$

and when  $m = 3$ —

$$(\text{max.}) v = \frac{\rho r^4}{Et^3}$$

which is  $\frac{3}{5}$  of that when the plate with the same central load rests on its edge (see (16), Art. 151).

**154. Approximate Methods applicable to Non-circular Plates.**—By the following roughly approximate method we can estimate the maximum bending stress in symmetrically shaped plates from the average bending stress perpendicular to an axis of symmetry. Results are subject to a numerical coefficient to be estimated from experiment or comparison with the more rigorous examination of circular plates made in the preceding articles. The method depends upon estimating the bending moment on a section of the plate through an axis of symmetry, from the loads and reactions of the supports on one side of that axis, and is therefore only applicable to “supported” and not to “clamped” plates. However, the preceding articles show that, in the case of circular plates, the stress and strain are greatest in the simply supported plates, and in practice the “clamping” of the edges of a plate cannot always be relied upon to entirely prevent such small inclinations of the plate as are consistent with “free support” at the edge. In a freely supported plate the maximum stress will generally occur at the centre, and in a “clamped” plate it will generally occur at an outer edge. Imperfect clamping *may* result in removing so much of the inclination at the supported edges as to equalise the stresses at the centre and edges of the plate and so realise the maximum strength of the plate; a similar remark with regard to the analogous case of “built-in” beams was made in Art. 84.

*Application to Circular Plates. Uniform Pressure  $p$  per Unit Area*

(Fig. 194).—Considering the half-plate ACB, the pressure on it is  $\frac{\pi r^2}{2} \cdot p$ , and the line of resultant pressure passes through the centroid  $G_1$  such that  $OG_1 = \frac{4r}{3\pi}$ . The reaction on the edge ACB is also  $\frac{\pi r^2}{2} \cdot p$ , and its centre of action is at  $G_2, \frac{2r}{\pi}$  from O. The resulting bending moment across the section AOB due to the load and reaction is—

$$M = \frac{\pi r^2}{2} \cdot p \left( \frac{2r}{\pi} - \frac{4r}{3\pi} \right) = \frac{pr^3}{3} \dots \dots \dots (1)$$

We may calculate an *average* intensity of bending stress at the outside surfaces of the section AOB in a direction perpendicular to AB by dividing the bending moment by the modulus of section of AB, viz. by  $\frac{1}{6} \cdot 2r \cdot t^2$  or  $\frac{1}{3}rt^2$ ; this gives—

$$\frac{pr^3}{3} \div \frac{1}{3}rt^2 = p \cdot \frac{r^2}{t^2} \dots \dots \dots (2)$$

But (10), Art. 149, shows that to give the greatest intensity of stress, at O, this average value must be multiplied by a coefficient  $\frac{3}{8} \cdot \frac{3m + 1}{m}$  or 1.25 when  $m = 3$ , giving a maximum intensity of stress  $1.25 p \frac{r^2}{t^2}$ .

To get the stress (E.e) which would alone produce the same maximum strain, it is necessary to multiply by the additional coefficient  $\frac{m - 1}{m}$  or  $\frac{2}{3}$  when  $m = 3$ , giving  $\frac{5}{6} \cdot p \cdot \frac{r^2}{t^2}$ .

*Central Load W.*—If the load W is uniformly distributed over a concentric circle of radius  $r_0$  (Fig. 196), the moment about AB is—

$$\frac{W}{2} \left( \frac{2r}{\pi} - \frac{4r_0}{3\pi} \right) = \frac{W}{\pi} \left( r - \frac{2r_0}{3} \right)$$

and the modulus being  $\frac{1}{3}rt^2$  as above, the average intensity of bending stress would be—

$$\frac{W}{\pi t^2} \left( 3 - 2 \frac{r_0}{r} \right) \dots \dots \dots (3)$$

The numerical coefficient to give the maximum intensity of stress at the centre ((10), Art. 151) will depend upon the ratio of  $r_0$  to  $r$ ; for large values of  $\frac{r_0}{r}$ , taking  $m = 3$ , it will approach 1.25, and for smaller values it will be greater, e.g. for  $\frac{r_0}{r} = \frac{1}{10}$  its value would be nearly 2.2.

**155. Oval Plate under Uniform Pressure and supported at its Perimeter.**—In the case of elliptical or other oval plates symmetrical about two perpendicular axes, we shall only seek to justify a roughly approximate empirical rule for the calculation of bending stress



designed to fit extreme cases. If ABCD (Fig. 198) is such an oval plate supported at its perimeter, the principal semi-axes OA and OB being  $a$  and  $b$  respectively, the maximum deflection  $\delta$  will evidently occur at the centre O, where the slope  $\theta$  will be zero. The average slope along OB will be  $\frac{\delta}{b}$ , and the average curvature or change of slope per unit of length will be  $\frac{\delta}{b^2}$ , the actual curvature in a meridian plane varying and reaching a maximum at O. Similarly, the mean curvature in a meridian plane

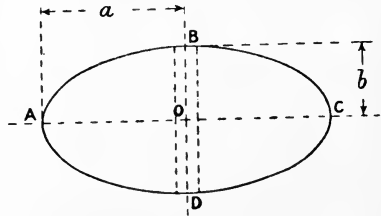

FIG. 198.

through OA will be  $\frac{\delta}{a^2}$  rising to a maximum at O. At the centre O, where the slope is zero, we may take it from the theory of bending or from (6), Art. 148, that the intensity of bending stress varies in different directions proportionally to the curvature  $(\frac{d\theta}{dx})$ , and if the variation of stress along OA and OB follow similar rules, the bending stress at O in the direction OB, *i.e.* across the section AC, is  $\frac{a^2}{b^2}$  times that in the direction at right angles to it. Hence, if  $a$  is greater than  $b$ , the bending stress at O in the direction OB is greater than that at right angles to it, and will be the greatest in any direction.

Consider a very elongated oval in which  $a$  is very great and  $b$  is very small; if a narrow strip of, say, unit width be cut with BD as centre line, a uniform pressure  $p$  would cause on it at O a bending moment  $\frac{1}{8}p(2b)^2$  or  $\frac{1}{2}pb^2$ , and the modulus of section of this strip being  $\frac{1}{6}t^2$ , the intensity of bending stress  $\frac{1}{2}pb^2 \div \frac{1}{6}t^2$  would be—

$$3p \frac{b^2}{t^2} \dots \dots \dots (1)$$

In an actual oval, the plate not cut into strips, the effect of the neighbouring (shorter) strips would be to reduce the value (1), which must be looked upon as an upper limit for a very long oval.

In the other extreme case of an ellipse, *viz.* the circle where  $a = b$ , the stress at the centre is about  $1.25p \frac{b^2}{t^2}$  ((11), Art. 149), and for intermediate cases we may frame an empirical rule by using a coefficient which is a linear function of  $\frac{b}{a}$ , varying from, say,  $2\frac{1}{2}$  when  $\frac{b}{a} = 0$  to  $1.25$  when  $\frac{b}{a} = 1$ , so that the greatest intensity of bending stress is approximately—

$$1.25 \left( 2 - \frac{b}{a} \right) p \cdot \frac{b^2}{t^2} \dots \dots \dots (2)$$

A similar rule might be made for the case of a central load.

**156. Square Plate under Uniform Pressure and supported at its Perimeter.**—If ABCD (Fig. 199) represents a square supported

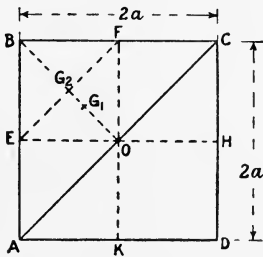

FIG. 199.

along its perimeter AEBFCHDK, we might take bending moments about a diagonal or about an axis of symmetry perpendicular to a side; in the latter case the unknown distribution of the reaction along the edges presents a difficulty, hence we choose a section along a diagonal AC. But the bending-stress intensity at O is by symmetry the same in the perpendicular directions OC and OB. The intensity is also by symmetry the same in the perpendicular directions OF and OH, hence,

for a central point on the plate at O, the ellipse of stress (Art. 16) is a circle, and in no direction does the bending stress exceed that perpendicular to the chosen diagonal section AC. If  $2a$  be the length of the sides of the square and  $p$  the pressure per unit area, the pressure on half the square will be  $2a^2 \cdot p$ . The reaction  $pa^2$  on one side BC, however it is distributed, will have a resultant at the middle point F of the side. Similarly, the reaction on the edge AB will have a resultant  $pa^2$  at E, hence the total reaction of the two sides AB and BC will be at  $G_2$ , midway between E and F, and distant  $\frac{a}{\sqrt{2}}$  from AC. The centre of the pressure on the triangle ABC will be at  $G_1$ ,  $\frac{1}{3}OB$  or  $\frac{\sqrt{2}}{3}a$  from AC, hence the bending moment on the section AC is—

$$2a^2p \left( \frac{a}{\sqrt{2}} - \frac{\sqrt{2}}{3}a \right) = \frac{2a^3p}{3\sqrt{2}}$$

and the thickness of the plate being  $t$ , the modulus of the section on the diagonal AC is—

$$\frac{1}{6} \cdot 2\sqrt{2} \cdot a \cdot t^2 = \frac{\sqrt{2}}{3} \cdot a \cdot t$$

hence the mean intensity of the bending stress at the skin across AC is—

$$\frac{2a^3p}{3\sqrt{2}} \div \frac{\sqrt{2}}{3}at^2 = p \cdot \frac{a^2}{t^2} \dots \dots \dots (I)$$

as on a circle of diameter equal to the side of the square (2), Art. 154).

**157. Rectangular Plate under Uniform Pressure and supported at the Perimeter.**—Let the sides AB and BC of the rectangle ABCD (Fig. 200) be  $2a$  and  $2b$  respectively. Then if the sides are not very unequal, we may take it that the stress across a diagonal AC is about as great as in any other direction. Let NB be a perpendicular from B on the diagonal AC. The resultant reaction at the edges AB and BC being at

the middle points E and F, the resultant reaction on the half-rectangle ABC is in the line EF and is distant  $\frac{1}{2}BN$  from AC. The centre of pressure on the triangle ABC is at the centroid and distant  $\frac{1}{3}BN$  from

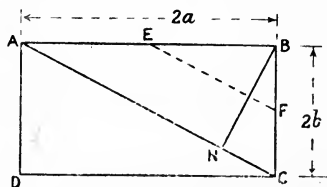

FIG. 200.

AC, and the magnitude of the pressure and reaction is  $2a \cdot b \cdot p$ ; hence the bending moment on AC is—

$$2ab \cdot p \left( \frac{1}{2}BN - \frac{1}{3}BN \right) = \frac{1}{3}ab \cdot p \cdot BN$$

and  $\frac{BN}{BC} = \frac{AB}{AC}$  or  $BN = \frac{4ab}{2\sqrt{a^2 + b^2}} = 2 \frac{ab}{\sqrt{a^2 + b^2}}$

The moment of resistance of the section AC is—

$$\frac{1}{6} \times 2\sqrt{a^2 + b^2} \times t^2 \times t^2 = \frac{t^2}{3} \sqrt{a^2 + b^2}$$

hence the average intensity of bending stress across AC is—

$$\frac{\frac{2}{3} \frac{a^2 b^2}{\sqrt{a^2 + b^2}} \cdot p}{\frac{t^2}{3} \sqrt{a^2 + b^2}} = \frac{2a^2}{a^2 + b^2} \cdot p \cdot \frac{b^2}{t^2} \dots (I)$$

For a very long rectangle in which  $\frac{a}{b}$  is great, this will approach—

$$2p \frac{b^2}{t^2}$$

and reasoning as for the limiting case of a very long oval, we may take it that the average stress across an axis parallel to the long sides then approaches—

$$3 \cdot p \cdot \frac{b^2}{t^2}$$

the formula applicable to a flooring supported by joists, where the bending parallel to the joists is negligible.

## EXAMPLES XIII.

1. A circular plate is 20 inches diameter and  $\frac{3}{4}$  inch thick; if it is simply supported at its perimeter, what pressure per square inch will it stand if the intensity of stress is not to exceed 10,000 lbs. per square inch? (Take Poisson's ratio as 0.3.)

2. What pressure may be allowed on the plate in problem No. 1, if the maximum principal strain is to be limited to that which would be produced by a simple direct stress of 10,000 lbs. per square inch?
3. Solve problem No. 1 for a circular plate clamped at its edge.
4. Solve problem No. 2 for a circular plate clamped at its edge.
5. What is the greatest allowable diameter for an unstayed flat circular plate  $\frac{1}{2}$  inch thick, supported at its circumference and subjected to a pressure of 100 lbs. per square inch, if the greatest stress is to be limited to 5 tons per square inch? (Poisson's ratio = 0.3.)
6. Estimate the safe pressure on an oval plate 1 inch thick, simply supported at its perimeter, if the greatest length is 30 inches and the greatest breadth 10 inches, and the allowable stress 10,000 lbs. per square inch.

## CHAPTER XIV.

### VIBRATIONS AND CRITICAL SPEEDS.

**158. Elastic Vibrations.**—When a body held in position by elastic constraints is disturbed from its position of equilibrium, it executes vibrations the nature of which is determined by the mass or inertia of the system, the stiffness of the constraints, the elastic forces of which govern the motion, and the amount of the disturbance. The greater the amplitude of the motion the greater are the strains, and consequently the stresses, caused in the supports or constraints of the body. It is the existence of these stresses and strains which makes the study of vibration of importance in the subject of Strength of Materials, and it is to be remembered that vibratory stresses are of a fluctuating and often of an alternating character, so that the stress intensities must be lower than are permissible with static loads.

Exact calculation of the motion in a vibrating elastic system is often a matter of great complexity, but very closely approximate calculations are frequently very simple.

Three kinds of vibration of straight bars will be considered, viz. Longitudinal, Transverse, and Torsional vibrations, the elastic forces being those arising from longitudinal, bending, and twisting strains of the bar. In many cases the inertia of the bar is negligible in comparison with that of attached masses, while in other cases the attached masses may be zero or their inertia negligible in comparison with that of the rod.

**159. Free or Natural Vibrations.**—Suppose a body to be held in position by supports in which it causes strains within the elastic limit; the elastic forces of the supports or constraints are just such as will produce equilibrium of the body. If the body receives a linear or angular displacement, say, due to an impact or the sudden addition or removal of a definite mass, the elastic force of the constraints in the disturbed position will not generally be such as will produce equilibrium, and vibrations will ensue. Such vibrations, maintained by the action of the elastic forces of the constraints alone, are called *free* or *natural* vibrations. Their frequency depends upon the inertia of the system and the stiffness of the elastic constraints, and their amplitude upon the magnitude of the initial disturbance. If no subsequent disturbance occurs, the vibrations continue until gradually damped by frictional resisting forces which, however small, are always present.

The elastic forces being always proportional to the displacement, the motion of natural vibration will be of a "simple harmonic" character. A familiar instance is that of a weight hanging on a helical spring; in this case the vibrations are often of so large an amplitude and so low a frequency as to be easily discernible by the eye; in other cases the motion involved by the maximum strain is so small and so rapid as to be not plainly visible.

*Fundamental and Higher Vibrations.*—In the subject of Strength of Materials the most important vibration of a given kind is generally the slowest or fundamental vibration. Often other vibrations of greater frequency and smaller amplitude are possible, the relation of which to the fundamental is important in the production of sound.

*Relation of Inertia, Stiffness, and Frequency.*—(1) *Linear Vibration.*—Suppose the whole vibrating mass has the same linear motion, and its weight is  $W$  pounds, and suppose that the *stiffness* of the supports, or elastic force per unit deflection or per unit linear motion of  $W$ , is  $e$  pounds. Then using the ordinary relation for simple harmonic motion,<sup>1</sup> where  $T$  is the time of one complete "to and fro" vibration in seconds—

$$T = 2\pi\sqrt{\frac{W}{e \cdot g}} \dots \dots \dots (1)$$

The frequency or number of vibrations is—

$$n = \frac{1}{T} = \frac{1}{2\pi}\sqrt{\frac{eg}{W}} \text{ per second or } N = \frac{30}{\pi}\sqrt{\frac{eg}{W}} \text{ per minute } (2)$$

$g$  being the acceleration of gravity, *i.e.* about 32.2 feet per second per second if the stiffness  $e$  is in pounds per foot of deflection, or  $32.2 \times 12$  inches per second per second if  $e$  is in pounds per inch of deflection. We may also write equations (1) and (2)—

$$T = \frac{2\pi}{p} \quad n = \frac{p}{2\pi} \text{ per second } \dots \dots \dots (3)$$

where  $p$  is the constant angular velocity of a point moving in a circle, the projection of which on a diameter of the circle defines the simple harmonic motion of the vibrating weight  $W$ .

(2) *Angular or Torsional Vibrations.*—Suppose the whole mass has the same angular motion, and its weight is  $W$  pounds, and its radius of gyration about the axis of motion is  $k$  (feet or inches), and the torsional rigidity or stiffness is a moment  $C$  (pound-feet or pound-inches) per radian of twist, then, corresponding to (1), choosing either foot or inch units—

$$T = 2\pi\sqrt{\frac{I}{C}} \dots \dots \dots (4)$$

where  $I = \frac{W}{g} \cdot k^2$ , the (mass) moment of inertia of the weight  $W$  in

<sup>1</sup> See the Author's "Mechanics for Engineers," Chapter IV., or any text-book of Mechanics.

gravitational units,  $g$  being about  $32.2$  if the linear units are feet, and  $12 \times 32.2$  for inch units.

The frequency of vibration is—

$$n = \frac{1}{T} = \frac{1}{2\pi} \sqrt{\frac{C}{I}} \text{ per second} \quad \text{or} \quad N = \frac{30}{\pi} \sqrt{\frac{C}{I}} \text{ per minute} \quad (5)$$

The differential equation representing simple harmonic motion, and its solution, bring out the above relations very clearly.<sup>1</sup>

#### 160. Forced Vibrations: Critical Frequency: Dangerous Speeds.

—If a body held in position by elastic constraints is acted upon by a *periodic* disturbing force, vibrations having the same frequency as that of the disturbing force will be set up. Their amplitude, and therefore the stresses caused by them, depend upon the relation between the frequency of the disturbing force and that of the free or natural vibrations of the body under the action of its elastic supports.

In vibration the energy of the system (consisting of, say, a single load  $W$  and its elastic supports) changes in kind but not in amount. In the mean or central position the velocity of motion is a maximum, and the energy of the system is wholly kinetic; in the extreme positions the same amount of energy is wholly potential, being (neglecting any gravitational effect) elastic strain energy of the supports or constraints. In intermediate positions the same total energy is partly kinetic and partly potential. The intensity of stress in the elastic constraints is in all cases proportional to the square root of the elastic strain energy or resilience (see Arts. 42, 93, and 116).

*Critical Frequency.*—If the periodic force has exactly the same frequency as a natural frequency of vibration, it will, at each successive application, increase the total energy of the system, always acting in the direction of motion and never against it. The increase of energy involves additional strain energy, and therefore additional stress on the constraints, particularly in the extreme positions, and the increase may continue until the strain energy involves so great a stress intensity that the limit of elasticity is reached and the elastic conditions cease to hold good. This may involve a fracture or a change in natural period which prevents further damage from the same periodic force, but in any case the rhythmical application of even a small force of this critical frequency may cause large and serious stresses. When a disturbing force has this critical frequency which exactly synchronizes with the natural frequency, the condition is sometimes called one of *resonance*, from its acoustic analogue.

*Dangerous Speeds.*—A periodic disturbing force or moment may be resolved into harmonic components the frequencies of which are usually 2, 3, 4, 5, 6, etc., times that of the periodic disturbance; hence a periodic disturbance having a frequency of  $\frac{1}{2}$ ,  $\frac{1}{3}$ ,  $\frac{1}{4}$ , or  $\frac{1}{5}$ , etc., of the natural frequency may become dangerous through one of its harmonic components. In some instances parts of machines are so constructed as to have a natural frequency much below the running speeds; in such a

<sup>1</sup> See Lamb's "Infinitesimal Calculus," Art. 182.

case there is no danger of the frequency of a harmonic component of a disturbance arising from running approaching the natural frequency. In starting and increasing such a machine to its full speed the resonant condition exists for *so short a time* that no excessive stress results.

The effect of friction, which may be small when the vibrations are very small, may increase greatly with increased amplitude of vibration, and so prevent the vibrations arising from a periodic force of critical frequency attaining a very great amplitude.

It is not necessary that the frequency of a periodic disturbing force should be *exactly* the same as the natural frequency of the system in order to set up large vibrations; if it has nearly the same frequency it will act in the direction of motion for a large number of successive applications before becoming opposed to it, and thus may add to the system sufficient energy to cause strains beyond a safe limit. For example, if the natural frequency is 100 vibrations per second, and that of an applied force, say, 97 per second, the difference in time of a complete cycle is  $\frac{3}{9700}$  second; and dividing the period,  $\frac{1}{100}$  second, during which the motion is in one direction, by  $\frac{3}{9700}$ , it is evident that sixteen successive increments to the energy of the system may be given before the periodic force becomes opposed to the direction of vibratory motion. The differential equations of motion<sup>1</sup> representing the forced vibration of an elastic system under, say, a harmonic or cosine periodic force, framed in terms of acceleration or of energy, together with its solution, bring out very clearly the nature and amplitude of the forced vibrations; an idea of the modifying effects of friction may be obtained by including in the equation a term to represent the retarding force which increases with the velocity.

**161. Longitudinal Vibrations.**<sup>2</sup>—The extreme cases of a rod carrying no load and a rod carrying a mass so large that its own inertia is negligible will be considered separately.

*Unloaded Rod.*—In this case the frequencies are usually so great that

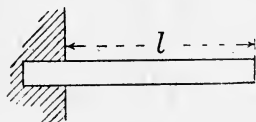

FIG. 201.

synchronism with them is not likely to occur in running machinery. If a rod of length  $l$  (Fig. 201) is fixed so as to prevent longitudinal displacement at one end, and free at the other, the fixed end forms a node or stationary point; the remainder of the rod has a longitudinal vibratory movement in which all parts move in the same direction at the same time, the amplitude of vibration at any point distant  $x$  from the fixed end or node being  $\sin\left(\frac{x}{l} \cdot \frac{\pi}{2}\right)$  times that at the free end. The frequency of the slowest or fundamental natural vibration is<sup>3</sup>—

$$n = \frac{1}{T} = \frac{1}{4l} \sqrt{\frac{EA g}{w}} \text{ or } \frac{1}{4} \sqrt{\frac{eg}{wl}} \text{ per second. . . (1)}$$

<sup>1</sup> See Lamb's "Infinitesimal Calculus," Arts. 186 and 187.

<sup>2</sup> See an article by the author in *Engineering*, vol. xc.

<sup>3</sup> See Rayleigh's "Theory of Sound," vol. i. Arts. 149-154; or Barton's "Sound," Art. 171.



where  $E$  is the direct modulus of elasticity,  $e \left( = \frac{AE}{l} \right)$  is the stiffness or force per unit of elongation,  $w$  is the weight of the material per unit length of rod,  $A$  is the area of cross-sectional area, and  $g$  is the acceleration of gravity, which is about  $32.2 \times 12$  inches per second per second. The frequency is independent of the cross-sectional area, for both  $e$  and  $w$  are proportional to  $A$ . If we take, as an example, a steel rod 10 feet long fixed at one end,  $E = 30 \times 10^6$  pounds per square inch, and the weight of steel 0.28 pound per cubic inch, the lowest frequency is—

$$n = \frac{1}{T} = \frac{1000}{480} \sqrt{\frac{30 \times 32.2 \times 12}{0.28}} = 424 \text{ per second}$$

a speed so high that cases of dangerous resonance in machinery are improbable.

If both ends of the rod are fixed the nodes are at the ends, hence the frequency is given by (1) if  $l$  is the half-length; if both ends are free longitudinally the node is at the centre, and the formula (1) again gives the frequency if  $l$  is the half-length.

*Loaded Rod.*—When the rod carries at its free end or point of maximum amplitude a load  $W$  pounds, so heavy that the inertia of the rod is negligible, the time of vibration and the frequency are given by the general formulæ (1) and (2), Art. 159, where  $e = \frac{AE}{l}$ , so that the natural frequency of vibration is—

$$n = \frac{1}{2\pi} \sqrt{\frac{AEg}{lW}} \text{ per second} \dots \dots (2)$$

If the weight of the rod is not negligible, but is small compared to the load, the amplitude of vibration of any point in the rod is practically proportional to the distance  $x$  from the fixed end (Fig. 202), hence if  $W'$  is the weight of the uniform rod, and  $v$  its velocity at a distance from the fixed end where  $V$  is the velocity of the free end, so that  $v = \frac{x}{l} \cdot V$ , the kinetic energy of an element of length  $\delta x$ , distant  $x$  from the fixed end, is—

$$\frac{1}{2} \frac{W'}{lg} \cdot \delta x \cdot v^2 = \frac{1}{2} \frac{W'V^2}{l^3g} \cdot x^2 \cdot \delta x$$

and the total kinetic energy of the rod is—

$$\frac{1}{2} \frac{W'V^2}{l^3g} \int_0^l x^2 dx = \frac{1}{3} \times \frac{1}{2} \times \frac{WV^2}{g}$$

Hence the mass of the rod is dynamically equivalent to  $\frac{1}{3}$  of the same amount at the free end, and may be taken into account, if necessary, by adding one-third of the weight of the rod to  $W$ .

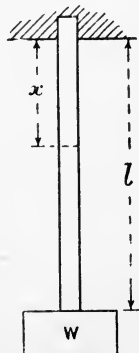
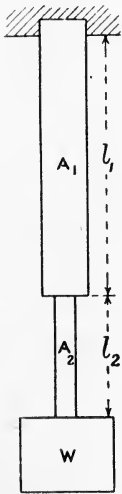

FIG. 202.

If the rod consists of two or more parts of length  $l_1, l_2$ , etc., and area of cross-section  $A_1$  and  $A_2$ , etc. (Fig. 203), the stiffness or force per unit deflection is evidently given by—



$$e\left(\frac{l_1}{A_1E} + \frac{l_2}{A_2E} +, \text{etc.}\right) = 1$$

or 
$$e\Sigma\left(\frac{l}{AE}\right) = 1$$

hence 
$$e = \frac{1}{\Sigma\left(\frac{l}{AE}\right)}$$

and the frequency (2), Art. 159, becomes—

$$n = \frac{1}{2\pi} \sqrt{\frac{Eg}{W\left(\frac{l_1}{A_1} + \frac{l_2}{A_2} +, \text{etc.}\right)}}$$

or 
$$\frac{1}{2\pi} \sqrt{\frac{Eg}{W\Sigma\left(\frac{l}{A}\right)}} \text{ per second} \quad \dots (3)$$

FIG. 203.

**162. Transverse Vibrations.**—When a bar makes transverse or flexural vibrations the extreme cases of the unloaded and heavily loaded bar may be treated separately. The vibration of the unloaded bar, which is of greater direct importance in the science of Sound than in Strength of Materials, is dealt with briefly in the next article, while in the present article a very closely approximate method of calculating the frequency of the fundamental vibration applicable to unloaded or loaded bars is given.<sup>1</sup>

This method consists in equating the strain energy which the bar would have in its static deflected position under the same load to the kinetic energy which the system would have in passing through its mean or undeflected position, when vibrating throughout its length with the same period and with an amplitude equal at every point to its static deflection at that point. This arbitrary assumption as to the amplitude of vibration is not strictly correct, particularly for the unloaded bar, but gives a very nearly correct result by a simple calculation (see Art. 163). An example will make the method clear.

*Bar carrying Uniform Load w per Unit Length, and simply supported at the Ends* (Fig. 112).—The deflection  $y$  at any point of the bar, distant  $x$  from one end ((9), Art. 78) is—

$$y = \frac{w}{24EI}(x^4 - 2lx^3 + l^3x) \dots (1)$$

where  $I$  is the moment of inertia of the area of cross-section, and  $l$  the length of the bar; the strain energy ((9), Art. 93) is—

$$\frac{w}{2} \int_0^l y dx$$

<sup>1</sup> See also an article by the author in *Engineering*, July 30 and Aug. 13, 1909.

If, vibrating about the undeflected position with amplitude  $y$ , the velocity of any point is  $\dot{p} \cdot y$ , where  $\dot{p}$  is the constant angular velocity of a point moving in a circle of radius  $y$ , which defines the simple harmonic motion, the kinetic energy of an element of length  $dx$  is then—

$$\frac{1}{2} \frac{w}{g} (\dot{p}y)^2 dx$$

hence, equating the total kinetic energy to the above strain energy—

$$\frac{1}{2} \frac{w}{g} \cdot \dot{p}^2 \int_0^l y^2 dx = \frac{1}{2} w \int_0^l y \cdot dx \quad \dots \quad (2)$$

$$\dot{p}^2 = g \int_0^l y dx \div \int_0^l y^2 \cdot dx$$

and substituting the value (1) of  $y$  and integrating—

$$\dot{p}^2 = \frac{24gEI}{wl^4} \left( \frac{1}{5} \div \frac{31}{630} \right) = \frac{3024}{31} \frac{gEI}{wl^4} = 97.55 \frac{gEI}{wl^4} \quad \dots \quad (3)$$

$$\dot{p} = \frac{9.877}{l^2} \sqrt{\frac{gEI}{w}} \quad \dots \quad (4)$$

$$\text{Frequency} = n = \frac{\dot{p}}{2\pi} = \frac{1.572}{l^2} \sqrt{\frac{gEI}{w}} \quad \dots \quad (5)$$

*Bar fixed at both Ends.*—If the bar is fixed in direction at both ends, from Art. 84—

$$y = \frac{w}{24EI} x^2(l-x)^2 = \frac{w}{24EI} (x^2l^2 - 2lx^3 + x^4)$$

and equation (2) gives—

$$\dot{p}^2 = \frac{24gEI}{wl^4} \left( \frac{1}{30} \div \frac{1}{630} \right) = \frac{504gEI}{wl^4} \quad \dots \quad (6)$$

$$\dot{p} = \frac{22.45}{l^2} \sqrt{\frac{gEI}{w}} \quad \dots \quad (7)$$

$$\text{Frequency} = \frac{\dot{p}}{2\pi} = \frac{3.57}{l^2} \sqrt{\frac{gEI}{w}} \text{ per second} \quad \dots \quad (8)$$

The same method may be applied to bars with other terminal conditions or carrying various types of load, using for the values of the deflection  $y$  those found in Chapters VI. and VII. Isolated loads involving discontinuity in the algebraic expression for  $y$ , if combined with other continuous loads, require the ranges of integration dividing into parts over which  $y$  is a continuous function of  $x$ . For isolated loads only the equation corresponding to (2) will be—

$$\frac{1}{2} \frac{\dot{p}^2}{g} \Sigma(Wy^2) = \frac{1}{2} \Sigma(W \cdot y) \quad \dots \quad (9)$$

*Heavy Single Load.*—When a bar carries a single load  $W$ , so heavy that other masses may be neglected, and of small dimensions compared with the length of the bar, formula (9) may be used, both sides being divided by  $\frac{1}{2}Wy$ ; this is equivalent to finding the stiffness  $e$ , and using it in the general formulæ (1) and (2), Art. 159. The value of  $e$  is found by equating to unity the expression for the deflection under a load  $e$ , placed in the position of the load  $W$ ; the various algebraic expressions for the deflection are to be found in Chapters VI. and VII.

For a heavy load  $W$  on a light rod of length  $l$  freely supported at the ends, if  $W$  divides  $l$  into two lengths  $a$  and  $b$ , from (8), Art. 80—

$$y = \frac{Wa^2b^2}{3EI\bar{l}}$$

and writing  $e$  for  $W$  and unity for  $y$ —

$$e = \frac{3EI\bar{l}}{a^2b^2} \dots \dots \dots (10)$$

hence from (2), Art. 159, the frequency of natural vibration is—

$$n = \frac{1}{2\pi} \sqrt{\frac{3EI\bar{g}\bar{l}}{Wa^2b^2}} \text{ per second } \dots \dots \dots (11)$$

or from (9), dividing each side by  $\frac{1}{2}Wy$ —

$$n = \frac{f}{2\pi} = \frac{1}{2\pi} \sqrt{\frac{g}{y}} = \frac{1}{2\pi} \sqrt{\frac{3EI\bar{g}\bar{l}}{Wa^2b^2}}$$

If the ends are fixed, from Ex. 2, Art. 87, the deflection under the load is—

$$y = \frac{Wa^2b^3}{3EI\bar{l}^3} \dots \dots \dots (12)$$

and the frequency of vibration is—

$$n = \frac{f}{2\pi} = \frac{1}{2\pi} \sqrt{\frac{g}{y}} = \frac{1}{2\pi} \sqrt{\frac{3EI\bar{g}\bar{l}^3}{Wa^2b^3}} \text{ per second } \dots \dots \dots (13)$$

If one end of the rod is fixed and the other free, and  $W$  is at a distance  $l_1$  from the fixed end, from (4), Art. 79—

$$y = \frac{Wl_1^3}{3EI}$$

$$n = \frac{1}{2\pi} \sqrt{\frac{3EI\bar{g}}{Wl_1^3}} \text{ per second } \dots \dots \dots (14)$$

Numerous other cases suggest themselves, and may be solved similarly.

*Effect of Size of Vibrating Load.*—If the vibrating load is not of small dimensions in comparison with the length of the shaft, it will be necessary to take account of the fact that it has a rotatory motion

about an axis perpendicular to the length of the bar and perpendicular to the plane of vibration. Let  $I'$  be its (mass) moment of inertia about this axis so that  $I' = \frac{W}{g} \cdot k^2$  where  $k$  is the radius of gyration of the load about this axis. We may illustrate the effect of this rotation on the above results by the case of the bar with one end fixed and the other free, loaded with the weight  $W$  at a distance  $l_1$  from the fixed end. If  $\theta$  is the slope of the axis of the bar at a distance  $l_1$  from the fixed end, from (3) and (4), Art. 79—

$$\theta = \frac{Wl_1^2}{2EI} \quad y = \frac{Wl_1^3}{3EI} \quad \theta = \frac{3}{2} \frac{y}{l_1}$$

The angular velocity of the load about the axis perpendicular to the bar and to the plane vibration is—

$$\frac{d\theta}{dt} = \frac{3}{2l_1} \frac{dy}{dt}$$

hence in passing through the mean position—

$$\left(\frac{d\theta}{dt}\right)^2 = \frac{9}{4l_1^2} \left(\frac{dy}{dt}\right)^2 = \frac{9}{4l_1^2} p^2 y^2$$

and the kinetic energy of rotation is—

$$\frac{1}{2} I' \left(\frac{d\theta}{dt}\right)^2 = \frac{1}{2} I' \frac{9}{4l_1^2} p^2 y^2$$

hence, equating the total kinetic energy to the strain energy by adding to the general formula (9) a term giving the rotational energy—

$$\frac{1}{2} \frac{W}{g} p^2 y^2 + \frac{1}{2} I' \frac{9}{4l_1^2} p^2 y^2 = \frac{1}{2} W y \dots \dots \dots (15)$$

$$p^2 = \frac{3EIg}{Wl_1^3 \left(1 + \frac{9I'g}{4l_1^2 W}\right)} \dots \dots (16)$$

and the frequency—

$$n = \frac{p}{2\pi} = \frac{1}{2\pi} \sqrt{\frac{3EIg}{Wl_1^3 \left(1 + \frac{9I'g}{4l_1^2 W}\right)}} \quad \text{or} \quad \frac{1}{2\pi} \sqrt{\frac{3EIg}{Wl_1^3 \left(1 + \frac{9}{4} \frac{k^2}{l_1^2}\right)}} \quad (17)$$

instead of the value (14). In the case of pulleys on shafts the term  $\frac{9k^2}{4l_1^2}$  or  $\frac{9I'g}{4l_1^2 W}$  is often so small as to be negligible in comparison with unity, in cases where the transverse frequency is so low as to be of importance.

The modifications appropriate to other cases with different end conditions can easily be made if necessary. In the important case of a single weight midway between similar bearings no correction is required, for evidently  $\theta$  and  $\frac{d\theta}{dt}$  are always zero.

*Single and Distributed Load.*—Applying the general method of this article to a single load at the centre of a bar simply supported at both ends, writing  $v = p \times \delta$  in (7) Art. 93A, and omitting the term  $w \cdot \delta$ , it is evident that the inertia is increased by an amount equivalent to a load  $\frac{1}{35}wl$  at the position of  $W$  (Fig. 111). Hence (11) becomes—

$$n = \frac{1}{2\pi} \sqrt{\frac{48E \cdot I \cdot g}{l^3(W + \frac{1}{35}wl)}}$$

For fixed ends similarly the frequency is—

$$n = \frac{1}{2\pi} \sqrt{\frac{192E \cdot I \cdot g}{l^3(W + \frac{13}{35}wl)}} \text{ corresponding to (13) when } w = 0$$

And for the cantilever loaded at the free end—

$$n = \frac{1}{2\pi} \sqrt{\frac{3E \cdot I \cdot g}{l^3(W + \frac{33}{140}wl)}} \text{ corresponding to (14) when } w = 0$$

The effect of the inertia of the bar in less simple positions of the point of impact may be similarly found by using suitable ranges in the integrations for total kinetic energy.

*Several Loads. Empirical Formula.*—If a bar carries several loads,  $W_1, W_2, W_3, W_4$ , etc., whether concentrated or distributed, and including the weight of the bar when not negligible, and the frequencies of vibration when the bar carries any one alone of these loads are  $n_1, n_2, n_3, n_4$ , etc., respectively, then if  $n$  is the frequency when the bar carries all the loads—

$$\frac{1}{n^2} = \frac{1}{n_1^2} + \frac{1}{n_2^2} + \frac{1}{n_3^2} + \frac{1}{n_4^2} +, \text{ etc. . . . (18)}$$

or,

$$T^2 = T_1^2 + T_2^2 + T_3^2 + T_4^2 +, \text{ etc. . . . (19)}$$

where  $T_1, T_2, T_3$ , etc., are the times of vibration for the separate loads, and  $T$  is the time of vibration for all the loads together. This empirical formula may be used as an alternative to (9) for the calculation of a complex system.

**163. Transverse Vibration of Unloaded Rods.**—Lord Rayleigh<sup>1</sup> has pointed out that for a rod making free transverse vibrations, different assumptions as to the deflection curve of the rod within wide limits make but small differences in the calculated frequencies. The method of the previous article takes advantage of this fact for approximate calculation, by assuming for an unloaded bar the particular form of the static deflection under the uniformly distributed load of its own weight which gives a simple algebraic expression. The more usual calculation is briefly as follows:—

Let  $y$  be the deflection of a point of a thin bar, distant  $x$  along the bar from a chosen origin, at a time  $t$ , and let  $y'$  be the amplitude of vibration or extreme value of  $y$  at this point. Then if  $w$  is the weight

<sup>1</sup> "Theory of Sound," Art. 182.

per unit length of bar, the elastic force *towards* the undeflected position, per unit of length, is  $\frac{w}{g} \times \frac{d^2y}{dt^2}$ . Hence, corresponding to equation (6), Art. 77—

$$EI \frac{d^4y}{dx^4} = -\frac{w}{g} \frac{d^2y}{dt^2}, \text{ or } \frac{d^4y}{dx^4} + \frac{w}{gEI} \frac{d^2y}{dt^2} = 0 \dots \dots (1)$$

Assume  $y$  to be harmonic, so that—

$$y = y' \cos m^2 \sqrt{\frac{gEI}{w}} t \dots \dots \dots (2)$$

which goes through a cycle in a time  $\frac{2\pi}{m^2} \sqrt{\frac{w}{gEI}}$

and has a frequency  $n = \frac{m^2}{2\pi} \sqrt{\frac{gEI}{w}}$

where  $m$  is simply a number; substituting this value (2) of  $y$ , equation (1) becomes—

$$\frac{d^4y'}{dx^4} - m^4y' = 0 \dots \dots \dots (3)$$

where  $m^4 = \frac{4\pi^2 n^2 w}{gEI}$  or  $\frac{p^2 w}{gEI}$  where  $p = 2\pi n$

the angular velocity corresponding to the simple harmonic motion. The solution of this equation is<sup>1</sup> the sum of the solutions of the two equations  $\frac{d^2y'}{dx^2} + m^2y' = 0$  and  $\frac{d^2y'}{dx^2} - m^2y' = 0$ , viz.—

$$y' = A \cos mx + B \sin mx + C \cosh mx + D \sinh mx. \quad (4)$$

the four arbitrary constants A, B, C, and D being made to satisfy the end conditions of the rod, as in Chapter VI. Four conditions are sufficient to eliminate three of the constants and to give an equation which must be satisfied by  $m$ , and this from (2) gives the frequency.

The case of a bar of length  $l$  simply supported at each end may be chosen for illustration; if the origin is at one end,  $y = 0 = \frac{d^2y}{dx^2}$  for  $x = 0$  and for  $x = l$ . Putting  $x = 0$  in (4),  $A + C = 0$ .

Differentiating (4) twice, and putting  $\frac{d^2y}{dx^2} = 0$ ,  $-A + C = 0$ , hence  $A = C = 0$ .

Putting  $x = l$  in (4),  $B \sin ml + D \sinh ml = 0$ .

Differentiating (4) twice, and putting  $\frac{d^2y}{dx^2} = 0$ —

$$-B \sin ml + D \sinh ml = 0; \text{ hence } 2B \sin ml = 0.$$

If  $B = 0$  or  $m = 0$ ,  $y' = 0$  for all values of  $x$ , and the bar is at rest. If B is not zero, and  $\sin ml = 0$ ,  $ml = \pi$ , or  $2\pi, 3\pi, 4\pi$ , etc.

<sup>1</sup> See Lamb's "Infinitesimal Calculus," Art. 189.

Taking the first value which corresponds to the slowest rate of vibration  $m = \frac{\pi}{l}$ , the frequency from (2) is—

$$n = \frac{m^2}{2\pi} \sqrt{\frac{gEI}{w}} = \frac{\pi}{2l^2} \sqrt{\frac{gEI}{w}} \dots \dots \dots (5)$$

A comparison of this with (5), Art. 162, shows how close is the agreement with the approximate calculation. Taking a round steel shaft of diameter  $d$  inches and length  $l$  inches,  $w = 0.28 \times \frac{\pi}{4} d^2$  pounds,  $I = \frac{\pi}{64} d^4$ ,  $g = 32.2 \times 12$  inches per second per second.  $E = 30 \times 10^6$  pounds per square inch, hence the number of vibrations per minute is given by—

$$N = \frac{60\pi}{2l^2} \sqrt{\frac{32.2 \times 12 \times 30 \times 10^6 \times \pi d^4 \times 4}{0.28 \times \pi d^2 \times 64}} = \frac{4,800,000d}{l^2} \dots (6)$$

The frequencies in this case are proportional to  $m^2$ , hence, for the second and subsequent modes of vibration and values of  $m$ , the frequencies are 4, 9, 16, 25, etc., times as great as for the fundamental or slowest vibration. Critical or resonant speeds of forced vibration may occur with any of these modes of vibration, but the slowest or fundamental is the commonest for ordinary working speeds of machinery. For other conditions of the ends of the bar different modes of vibration occur. The solutions will be found in books on Sound.<sup>1</sup> For a bar fixed at each end,  $\cos ml \cosh ml = 1$ , and for the slowest vibration the solution is  $ml = 4.73$ , or roughly  $\frac{3\pi}{2}$ . For a bar fixed at one end and free at the other,  $\cos ml \cosh ml = -1$ , and for the slowest vibrations the solution is  $ml = 1.875$ . For a bar fixed at one end and supported at the other,  $\cot ml = \coth ml$ , and the first solution is  $ml = 3.927$ .

**164. Whirling Speed of Rotating Shafts.**—When a round shaft is rotating, the centre line of the shaft will not coincide with mathematical exactness with the axis of rotation owing to the weight of the shaft, want of straightness, vibration, and other causes. Hence centrifugal forces due to the inertia of the shaft will produce a bending moment on the shaft tending to deflect it, increased deflection giving greater centrifugal forces. These deflecting forces are proportional to the square of the speed and to the deflection, and are resisted only by the elastic forces of the shaft, hence, as the speed of rotation increases, a value will be reached at which the centrifugal force will exceed the elastic forces, and the deflection and stress, unless prevented, will increase until fracture occurs. This critical speed at which instability sets in is called the *whirling* speed of the shaft.

For an unloaded shaft, or for a shaft of negligible inertia carrying a

<sup>1</sup> See Rayleigh's "Theory of Sound," vol. i. Arts. 161-181; or Barton's "Sound," Arts. 198-217.



heavy load the radius of gyration of which is negligible compared with the length of the shaft, the whirling speed is the same as the natural frequency of transverse vibration under the same conditions of support. If we regard the centrifugal forces exerted by any portion of the shaft, resolved in any plane containing the axis of rotation, as a disturbing force on the remaining portion, we might regard the phenomenon of whirling as resulting from the coincidence of the frequency of forced vibration with the frequency of natural transverse vibrations of the shaft. Perhaps a better point of view is to regard the centrifugal forces of the rotating shaft as counteracting the elastic forces which tend to straighten the shaft, and so reducing the stiffness, the flexural stiffness of a rotating shaft being dependent upon the righting force resulting from the joint action of the elastic and centrifugal forces; the whirling speed is then that at which the stiffness becomes zero and the period infinite, or the frequency *nil*.

*Unloaded Shaft.*—Let  $w$  be the weight of shaft in pounds per unit length,  $I$  the moment of inertia of the cross-sectional area about a diameter, viz.  $\frac{\pi}{64}d^4$  where  $d$  is the diameter,  $E$  be the direct modulus of elasticity of the material, and  $\omega$  the angular velocity in radians per second. Taking the axis of rotation as axis of  $x$ , and the variable deflections of the centre line of the shaft from the axis of rotation as  $y$ , neglecting the effect of gravity, the centrifugal bending force per unit length is—

$$\frac{w}{g} \cdot \omega^2 \cdot y$$

Using this instead of  $w$ , equation (6), Art. 77, becomes—

$$\frac{d^4y}{dx^4} = \frac{w\omega^2}{gEI} \cdot y \dots \dots \dots (1)$$

or, 
$$\frac{d^4y}{dx^4} - m^4y = 0 \dots \dots \dots (2)$$

where 
$$m^4 = \frac{w\omega^2}{gEI} \dots \dots \dots (3)$$

The equation (2) is identical with equation (3), Art. 163, if  $\omega = p$ , hence the whirling speeds in revolutions per second are the same as the frequencies of transverse vibration. These have been given for various cases in Art. 163, and it is unnecessary to repeat them; for practical use the formulæ for various cases may be reduced as shown in (6), Art. 163. In the case of a shaft, a very short or a swivelling bearing will approximate to a "support," and a long rigid bearing will give approximately the condition of a fixed end. The approximate values (4), (5), (7), and (8) of Art. 162, and others similarly obtained are, of course, valid for the whirling speeds.

Critical or whirling speeds other than the fundamental or lowest value will occur at higher speeds, as indicated in Art. 163, the quantity  $m^4$  having a series of values which satisfy the conditions.

*Single Loads.*—When a shaft carries a load  $W$ , so heavy that the mass of the shaft is negligible, and of dimensions small compared to the length of the shaft, the critical speed of rotation is that at which the centrifugal force of the load is just equal to the elastic righting force of the shaft. If  $\omega$  is this critical velocity, and  $y$  is the deflection of the centre of gravity of the load from the centre of rotation, and  $e$  is the stiffness or elastic force per unit deflection of the shaft at the point of attachment of the load, equating the centrifugal force to the elastic force—

$$\frac{W}{g}\omega^2 y = ey \quad \dots \quad (4)$$

$$\omega^2 = \frac{eg}{W} \quad \omega = \sqrt{\frac{eg}{W}} \quad \dots \quad (5)$$

and the speed in revolutions per second is—

$$n = \frac{\omega}{2\pi} = \frac{1}{2\pi} \sqrt{\frac{eg}{W}} \quad \dots \quad (6)$$

which is the same as that calculated for the transverse vibrations (11), (13), (14), Art. 162, and the general vibration formula (2), Art. 159.

*Deflection at Other Speeds.*—Suppose that initially the centre of gravity of the load deviates by an amount  $h$  from the centre line of rotation; then at any speed  $\omega$ , equating the centrifugal force to the elastic righting force of the shaft—

$$\frac{W}{g}\omega^2(h + y) = e \cdot y \quad \dots \quad (7)$$

$$y = h \cdot \frac{W\omega^2}{eg - W\omega^2} = -h \cdot \frac{W\omega^2}{W\omega^2 - eg} \quad \dots \quad (8)$$

This reaches the value infinity for the critical value  $\omega^2 = \frac{eg}{W}$ ; for lower values of  $\omega$  it varies from zero to infinity; for higher values of  $\omega$ ,  $y$  is negative and approaches the value  $-h$ . If the shaft is initially straight and true, and the deviation  $h$  is due to the load being out of balance, *i.e.* its centre of gravity not coinciding with the centre of the shaft, the approach of  $y$  to the value  $-h$  means that above the critical speed the weight rotates about an axis which approaches its centre of gravity more and more nearly as the speed increases. (This is the principle of the flexible shaft of the De Laval steam turbine.) If the weight is in perfect balance, and the initial deviation  $h$  is due to want of straightness of the shaft (since  $y$  represents deflections of the shaft) the deviation of the centre of gravity of the weight from the axis of rotation is—

$$h + y = h \cdot \frac{eg}{eg - W\omega^2} = -h \cdot \frac{eg}{W\omega^2 - eg} \quad \dots \quad (9)$$

Below the critical velocity this varies from  $h$  to infinity, and above the critical velocity it approaches the value zero, *i.e.* the rotation tends to straighten the shaft. That rupture does not occur in passing

through the critical speed is due to the circumstance that the interval of time, during which the speed has the critical value, is too small for a large deflection to occur. Equation (8), which may be written—

$$y = h \frac{\omega^2}{\frac{eg}{W} - \omega^2} \quad \text{or} \quad h \frac{\omega^2}{\omega_c^2 - \omega^2} \quad \text{or} \quad -h \frac{\omega^2}{\omega^2 - \omega_c^2} \quad \dots \quad (10)$$

where  $\omega_c$  is the critical value  $\sqrt{\frac{eg}{W}}$ , shows that if  $\omega$  remains *nearly* equal to the critical value the deflection, and therefore the intensity of stress, may be unduly great.

*Effect of Size of Load.*—If the rotating load were not of small dimensions in comparison with the length of the shaft, it would be necessary to take account of the fact that, owing to the deflection of the shaft, every portion of the rotating weight is constantly changing its plane of rotation. (An important exception occurs in the case of a single load placed midway between similar bearings.) The more exact values in such cases, as well as much information on the subject of Whirling of Shafts, is to be found in papers by Professor Dunkerley<sup>1</sup> and Dr. Chree<sup>2</sup> and the Author.<sup>3</sup>

*Several Loads.*—When a shaft carries several loads, the critical speeds of rotation may be found by the empirical formula (8) of Art. 162, which has been verified experimentally. The same formula may be used in cases where the inertia of the shaft itself is not negligible. A number of practical rules for shafts loaded and supported in various ways is to be found in a paper by Professor Dunkerley in the *Proceedings of the Liverpool Engineering Society*, December, 1894.

EXAMPLE 1.—Find the whirling speed of a steel shaft 1 inch diameter and 5 feet long, supported in short bearings, which do not constrain its direction, at its ends.

From equation (6), Art. 163—

$$N = \frac{4,800,000}{60 \times 60} = 1333 \text{ revolutions per minute}$$

EXAMPLE 2.—A vertical steel shaft  $\frac{1}{4}$  inch diameter and  $7\frac{1}{2}$  inches between the long bearings at its ends, carries a wheel weighing 4 pounds midway between the bearings. Neglecting any increase of stiffness due to the attachment of the wheel to the shaft, find the critical speed of rotation and the maximum bending stress when the shaft is rotating at  $\frac{9}{10}$  of this speed, if the centre of gravity of the wheel is  $\frac{1}{100}$  inch from the centre of the shaft.  $E = 30 \times 10^6$  pounds per square inch.

From Ex. 2, Art. 86, the stiffness  $e$ , or force per inch deflection at the load, is—

$$e = \frac{192EI}{l^3}$$

<sup>1</sup> *Phil. Trans. Roy. Soc.*, 1894, vol. 185.

<sup>2</sup> *Phil. Mag.*, May, 1904; or *Proc. Phys. Soc.*, vol. xix.

<sup>3</sup> *Engineering*, July 30 and Aug. 13, 1909.

hence the critical velocity in revolutions per second is—

$$\begin{aligned} \frac{60}{2\pi} \sqrt{\frac{e \cdot g}{W}} &= \frac{30}{\pi} \sqrt{\frac{192E \cdot I \cdot g}{Wl^3}} \\ &= \frac{30}{\pi} \sqrt{\frac{192 \times 30 \times 10^6 \times \pi \times 32 \cdot 2 \times 12 \times 8}{4 \times 64 \times 256 \times 15 \times 15 \times 15}} \\ &= 4800 \text{ revolutions per minute} \end{aligned}$$

At 0.9 of this speed, by (10), Art. 164, the central deflection is—

$$0 \cdot 01 \left\{ \frac{\omega^2}{\left(\frac{10}{9}\omega\right)^2} - \omega^2 \right\} = 0 \cdot 01 \times \frac{81}{19} = 0 \cdot 0426 \text{ inch}$$

The central (centrifugal) bending force is  $0 \cdot 0426 \times e$ , and the central bending moment (Ex. 2, Art. 86) is—

$$M = \frac{1}{8} \times 0 \cdot 0426 \times l \times e = \frac{0 \cdot 0426 \times 7 \cdot 5 \times e}{8} \text{ pound-inches}$$

and the maximum bending stress is—

$$\begin{aligned} \frac{M}{Z} &= \frac{M}{8 \times I} = \frac{0 \cdot 0426 \times 7 \cdot 5 \times 192 \times 30 \times 10^6 \times I}{8 \times 8 \times I \times (7 \cdot 5)^3} \\ &= 68,160 \text{ pounds per square inch} \end{aligned}$$

EXAMPLE 3.—Solve Ex. 2 if the shaft bearings do not fix its direction at the ends.

In this case,  $e = \frac{48EI}{l^3}$ , or  $\frac{1}{4}$  of the previous value. Hence the critical speed is  $\sqrt{\frac{1}{4}}$  or  $\frac{1}{2}$  of the previous value, *i.e.*  $\frac{4800}{2} = 2400$  revolutions per minute.

At  $\frac{9}{10}$  of the critical speed the central deflection will be as before,  $0 \cdot 0426$  inch.

The equivalent central load,  $0 \cdot 0426 \times e$ , will be  $\frac{1}{4}$  of its previous value, and the central bending moment will be—

$$\frac{1}{4} \times 0 \cdot 0426 \times e \times l$$

which is  $2 \times \frac{1}{4}$ , or  $\frac{1}{2}$  of its previous value, hence the bending stress will be  $\frac{1}{2}$  of its previous value, or—

$$\frac{68,160}{2} = 34,080 \text{ pounds per square inch}$$

**165. Transverse Vibration of Rotating Shafts.**—A rotating shaft, when laterally disturbed, has its elastic righting forces reduced by the centrifugal force arising from its own inertia, hence its stiffness and frequency of transverse vibration are reduced, and its period increased.

Let the natural frequency of the shaft when not rotating be  $\frac{p}{2\pi}$ , and

when rotating with angular velocity  $\omega$  be  $\frac{p'}{2\pi}$ . Then, from the equation (3) of Art. 163, allowing for the centrifugal force as in (2), Art. 164—

$$\frac{d^4y}{dx^4} - \frac{p'^2 + \omega^2}{gEI} \cdot \tau y = 0 \dots \dots \dots (1)$$

hence the vibrations are of the type in Art. 163, and

$$p'^2 + \omega^2 = p^2 \dots \dots \dots (2)$$

or, 
$$p'^2 = p^2 - \omega^2 \dots \dots \dots (3)$$

the frequency being—

$$n = \frac{1}{2\pi} \sqrt{p^2 - \omega^2} \dots \dots \dots (4)$$

and the time of vibration—

$$T = \frac{2\pi}{\sqrt{p^2 - \omega^2}} \dots \dots \dots (5)$$

We have seen in the previous article that the whirling speed is attained when  $\omega = p$ ; for a forced transverse vibration resulting from any periodic disturbance, apart from rotation, the critical frequency is that given by (4). Evidently the same holds good for a single weight on a shaft of negligible mass.

**166. End Thrust and Twist on Rotating Shaft.**—The decreased flexural stiffness resulting from rotation will evidently diminish the capacity of a shaft to withstand end thrust, *i.e.* it will reduce the collapsing load of the shaft considered as a strut. A single case will be sufficient to illustrate this. Take a rotating shaft of length  $l$ ,

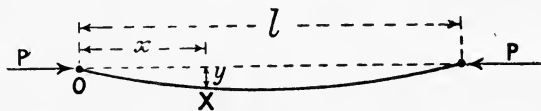

FIG. 204.

diameter  $d$ , and weight per unit length  $w$ , freely supported at its ends by bearings which do not constrain its direction, and in which it turns with an angular velocity  $\omega$ , and let it be subject to an end thrust  $P$  (Fig. 204). Taking the initial position of the axis of the shaft as axis of  $x$ , if  $y$  is the deflection at a distance  $x$  from one end  $O$ , due to end thrust alone, when a state of instability is reached, with the convention of signs used in Art. 77, the shaft being concave towards its unstrained position—

$$EI \frac{d^2y}{dx^2} = -P \cdot y \dots \dots \dots (1)$$

$$\frac{d^4y}{dx^4} = -\frac{P}{EI} \cdot \frac{d^2y}{dx^2}$$

Combining this with equation (1) of Art. 164, for end thrust and centrifugal force due to rotation—

$$\frac{d^4 y}{dx^4} + \frac{P}{EI} \cdot \frac{d^2 y}{dx^2} - \frac{w\omega^2}{gEI} \cdot y = 0 \quad \dots \quad (2)$$

The solution of this equation is the sum of the solutions of the equations—

$$\frac{d^2 y}{dx^2} + m_1^2 y = 0 \quad \text{and} \quad \frac{d^2 y}{dx^2} - m_2^2 y = 0$$

$$\text{where } m_1^2 = \sqrt{\frac{P^2}{4(EI)^2} + \frac{w\omega^2}{gEI}} + \frac{P}{2EI} \quad m_2^2 = \sqrt{\frac{P^2}{4(EI)^2} + \frac{w\omega^2}{gEI}} - \frac{P}{2EI}$$

$m_2^2$  and  $-m_1^2$  being the two roots of the quadratic equation—

$$m^4 + \frac{P}{EI} m^2 - \frac{w\omega^2}{gEI} = 0$$

hence the complete solution of equation (2) is—

$$y = A \cos m_1 x + B \sin m_1 x + C \cosh m_2 x + D \sinh m_2 x \quad (3)$$

$$\text{And since } y = 0 = \frac{d^2 y}{dx^2} \text{ for } x = 0 -$$

$$A = 0 \quad C = 0$$

$$\text{And putting } y = 0 = \frac{d^2 y}{dx^2} \text{ for } x = l -$$

$$(m_1^2 + m_2^2)B \sin m_1 l = 0$$

since  $m_1^2 + m_2^2$  is not zero, unless  $B = 0$  (in which case  $y = 0$ , and there is no bending)—

$$\sin m_1 l = 0 \quad \dots \quad (4)$$

*i.e.* under the unstable conditions—

$$m_1 l = \pi, 2\pi, 3\pi, \text{ etc.} \quad \dots \quad (5)$$

Taking the lowest speed,  $m_1 = \frac{\pi}{l}$ —

$$m_1^2 = \sqrt{\frac{P^2}{4(EI)^2} + \frac{w\omega^2}{gEI}} + \frac{P}{2EI} = \frac{\pi^2}{l^2} \quad \dots \quad (6)$$

This gives the limiting value of  $P$  for stability with rotation at a given speed  $\omega$ , or gives the critical value of  $\omega$  under a given thrust  $P$ ; the value  $\omega$ , and therefore the frequency, is reduced by  $P$ . If  $P = 0$ , (6) reduces to the form (5), Art. 163, which gives the whirling speed of the shaft with no end thrust, Art. 164. If  $\omega = 0$ , equation (6) reduces to Euler's limiting value for this shaft considered as a stationary strut.

The formula is evidently only a limiting value subject to limitations in actual shafts due to want of straightness, gravitational and other transverse loads, etc. If the sign of  $P$  were reversed it is quite evident that the critical or whirling speed will be raised instead of being lowered; in this case  $\omega$  may be found by reversing the sign of  $P$  in (6). The effect of eccentric end thrust, or transverse loads, might be taken into account as in Arts. 104 and 105.

In actual shafts the effect of end thrust in producing instability is usually very small in comparison with that of centrifugal forces.

A twisting moment  $T$  also has a small effect in producing instability, but it is usually negligible in comparison with the effect of a moderate end thrust, or with that of centrifugal forces. The condition of instability in a shaft freely supported at each end is given by the relation<sup>1</sup>—

$$\frac{P}{EI} + \frac{T^2}{4E^2I^2} = \frac{\pi^2}{l^2}$$

EXAMPLE 1.—Find the critical speed of the shaft in Ex. 1, Art. 164, if there is an axial thrust of 200 pounds. Weight of steel, 0.28 pound per cubic inch.  $E = 30 \times 10^6$  pounds per square inch.

$w$ , the weight per inch length =  $0.28 \times 0.7854 = 0.22$  pound

From (6)—

$$\frac{w\omega^2}{gEI} = \left( \frac{\pi^2}{l^2} - \frac{P}{2EI} \right)^2 - \frac{P^2}{4E^2I^2}$$

$$\frac{w\omega^2}{gEI} = \frac{\pi^4}{l^4} - \frac{\pi^2 P}{l^2 EI}$$

$$\omega = \sqrt{\frac{gEI}{w} \left( \frac{\pi^4}{l^4} - \frac{\pi^2 P}{l^2 EI} \right)}$$

$$= \sqrt{\frac{32.2 \times 12 \times 30 \times 10^6 \times \pi}{0.22 \times 64} \left( \frac{97.4}{12,960,000} - \frac{9.87 \times 200 \times 64}{3600 \times 30 \times 10^6 \times \pi} \right)}$$

= 136 radians per second

which is equal to  $\frac{30}{\pi} \times 136 = 1300$  revolutions per minute, the decrease due to the end thrust being about  $2\frac{1}{2}$  per cent.

**167. Torsional Vibrations.**—The various cases of torsional vibration are closely analogous to those of longitudinal vibration (Art. 161). The torsional rigidity varies with the form of cross-section (see Art. 112), and we shall consider only the case of shafts of circular section.

*Unloaded Shaft.*—In the case of a uniform shaft of diameter  $d$  and length  $l$  (Fig. 201), fixed so as to prevent twisting strain at one end and free at the other, the fixed end forms a node or stationary section; the remainder of the rod has a vibratory movement, in which every part at a given instant moves in a circle about the axis in the same sense. The angular amplitude of vibration of any point distant  $x$  from

<sup>1</sup> See a paper by Prof. Greenhill in *Proc. Inst. Mech. Eng.*, 1883.

the fixed end is  $\sin\left(\frac{x}{l} \frac{\pi}{2}\right)$  times that at the free end. The frequency of the slowest or fundamental natural vibration is<sup>1</sup>—

$$n = \frac{1}{T} = \frac{1}{4l} \sqrt{\frac{N \cdot A \cdot g}{w}} \dots \dots \dots (1)$$

where  $N$  is the modulus of transverse elasticity,  $A = \frac{\pi}{4}d^2$  is the area of cross-section of the shaft,  $w$  is the weight per unit length, and  $g$  is the acceleration of gravity,  $32.2 \times 12$  inches per second per second. The frequency is independent of the diameter ( $d$ ) of the bar, since  $w$  is proportional to  $A$ . As in the case of longitudinal vibration the natural frequency of unloaded shafts is so high that cases of resonance in machinery are improbable.

If both ends of the shaft are fixed the nodes are at the ends, hence the frequency is given by (1) if  $l$  is the *half-length*; if both ends are free the node is at the centre, and (1) again gives the frequency if  $l$  is the *half-length* of the shaft.

*Single Load.*—When the shaft with one end fixed carries at its free end, or section of maximum angular amplitude, a load  $W$  (Fig. 202), the (mass) moment of inertia  $I$  (or  $\frac{W}{g}k^2$ ) of which is so great that the (mass) moment of inertia of the shaft is negligible, the time of vibration and frequency of free or natural torsional vibrations are given by the general formulæ (4) and (5), Art. 159. If  $C$  is the “torsional rigidity” or twisting moment per radian of twist of a circular shaft ((3), Art. 109)—

$$C = \frac{NJ}{l}$$

where  $J = \frac{\pi}{32}d^4$ , the moment of inertia of the area of section about the axis, hence (5), Art. 159, becomes—

$$n = \frac{1}{2\pi} \sqrt{\frac{NJ}{Il}} \quad \text{or} \quad \frac{d^2}{20} \sqrt{\frac{N}{Il}} \quad \text{or} \quad \frac{1}{2\pi} \sqrt{\frac{NJg}{Wk^2l}}$$

$$\text{or} \quad \frac{d^2}{20} \sqrt{\frac{Ng}{Wk^2l}} \text{ per second} \dots \dots \dots (2)$$

where  $k$  is the radius of gyration of the load  $W$  and  $g$  is  $32.2 \times 12$  when inch units are used.

If we use pound and inch units, and take  $N = 12 \times 10^6$  pounds per square inch for steel, this reduces to—

$$n = 3400d^2 \sqrt{\frac{1}{Wk^2l}} \text{ per second} \dots \dots \dots (3)$$

The approximate correction to be made in (2), if the (mass) moment of inertia of the shaft is not quite negligible, is analogous to that

<sup>1</sup> See Rayleigh’s “Theory of Sound,” vol. i. Art. 159; or Barton’s “Sound,” Arts. 173 and 174.



for the case of longitudinal vibration, viz.  $\frac{1}{3}$  of the moment of inertia of the shaft is to be added to  $I$ .

If the shaft consists of two or more parts of lengths  $l_1, l_2$ , etc., and diameters  $d_1, d_2$ , etc. (Fig. 203), the twist caused by unit twisting moment is evidently the sum of that caused in each section, or—

$$\frac{I}{C} = \frac{I}{N} \left( \frac{l_1}{J_1} + \frac{l_2}{J_2} +, \text{etc.} \right) \quad \text{or} \quad \frac{32}{\pi N} \left( \frac{l_1}{d_1^4} + \frac{l_2}{d_2^4} +, \text{etc.} \right)$$

a method of calculating the torsional stiffness  $C$ , which may be used in all cases of shafts of varying diameter. From (3) the natural frequency is—

$$n = \frac{I}{2\pi} \sqrt{\frac{N}{I \left( \frac{l_1}{J_1} + \frac{l_2}{J_2} +, \text{etc.} \right)}} \quad \text{or} \quad \frac{I}{8\pi} \sqrt{\frac{\pi N}{2I \left( \frac{l_1}{d_1^4} + \frac{l_2}{d_2^4} +, \text{etc.} \right)}} \quad (4)$$

which may be written—

$$n = \frac{I}{2\pi} \sqrt{\frac{N}{I \Sigma \left( \frac{l}{J} \right)}} \quad \text{or} \quad \frac{I}{20} \sqrt{\frac{N}{I \Sigma \left( \frac{l}{d^4} \right)}} \quad \text{per second.} \quad (5)$$

or for steel, in inch and pound units—

$$n = 3400 \sqrt{\frac{I}{Wk^2 \Sigma \left( \frac{l}{d^4} \right)}} \dots \dots \dots (6)$$

The formulæ (4) and (5) are equivalent to using formula (2) with a diameter, say,  $d_1$ , and lengths made up of the several parts, each part, such as  $l_2$ , etc., being altered in the ratios  $\left( \frac{d_1}{d_2} \right)^4$ , etc. The method of using such an “equivalent length” is useful in all torsional-stiffness problems where the diameter of a shaft is different in different parts.

*Two Loads.*—If there are two loads on a free shaft of length  $l$  (Fig. 205), the node will be somewhere between them. Let  $l_1$  and  $l_2$  be the respective distances of the node from the loads of  $I_1$  and  $I_2$ , moments of inertia. Then the natural frequency of vibration of the system is the same as that of either load on a shaft fixed at the node and free at the corresponding load; hence from (2)—

$$n = \frac{I}{2\pi} \sqrt{\frac{NJ}{I_1 l_1}} = \frac{I}{2\pi} \sqrt{\frac{NJ}{I_2 l_2}} \dots \dots \dots (7)$$

hence

$$\frac{l_1}{l_2} = \frac{I_2}{I_1}$$

and the node divides the length  $l$  inversely as the moments of inertia of the loads. Also—

$$n = \frac{1}{2\pi} \sqrt{\frac{NJ(I_1 + I_2)}{lI_1I_2}} \quad \text{or} \quad \frac{1}{2\pi} \sqrt{\frac{NJ}{l} \left( \frac{1}{I_1} + \frac{1}{I_2} \right)} \quad \dots (8)$$

which might be put in a formula similar to (3). The equation (8) may also be written—

$$n^2 = n_1^2 + n_2^2 \quad \dots \dots \dots (9)$$

when  $n_1$  and  $n_2$  are the frequencies  $\frac{1}{2\pi} \sqrt{\frac{NJ}{I_1 l}}$  and  $\frac{1}{2\pi} \sqrt{\frac{NJ}{I_2 l}}$  of the shaft fixed at one end and carrying  $I_1$  and  $I_2$  respectively at the free end.

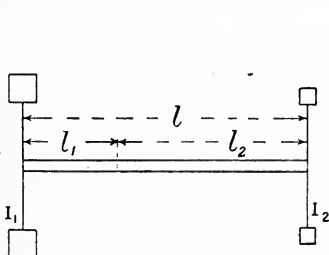

FIG. 205.

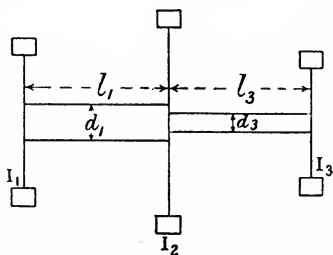

FIG. 206.

*Three Loads* (Fig. 206).—The lengths and diameters between the loads being unequal, taking—

$$C_1 = \frac{NJ_1}{l_1} = \frac{\pi N d_1^4}{32 l_1} \quad C_3 = \frac{NJ_3}{l_3} = \frac{\pi N d_3^4}{32 l_3}$$

for the left-hand portion alone and free at the ends, the frequencies would from (8) be—

$$n_1 = \frac{1}{2\pi} \sqrt{\frac{NJ_1}{l_1} \left( \frac{1}{I_1} + \frac{1}{I_2} \right)}$$

For the right-hand portion alone and free ends—

$$n_3 = \frac{1}{2\pi} \sqrt{\frac{NJ_3}{l_3} \left( \frac{1}{I_3} + \frac{1}{I_2} \right)}$$

For the left-hand portion alone if fixed at the outer end, from (4)—

$$n'_1 = \frac{1}{2\pi} \sqrt{\frac{NJ_1}{l_1 I_2}}$$

For the right-hand portion alone if fixed at the outer end—

$$n_3^r = \frac{1}{2\pi} \sqrt{\frac{NJ_3}{l_3 I_2}}$$

The frequencies  $n$  of the whole system are then given by the equation—

$$(n^2 - n_1^2)(n^2 - n_3^2) = (n_1' n_3')^2 \dots \dots \dots (10)$$

the roots of which are both real. The nature of the vibrations will vary with the relations of the values  $C_1, C_2, I_1, I_2,$  and  $I_3$ .

The equation (10) may be derived as follows: If nodes in the sections  $l_1$  and  $l_3$  fall at distances  $x$  and  $y$  respectively from  $I_1$  and  $I_3$ , the end loads have a time of vibration given by (2), as—

$$n = \frac{1}{2\pi} \sqrt{\frac{NJ_1}{I_1 x}} = \frac{1}{2\pi} \sqrt{\frac{NJ_3}{I_3 y}} \dots \dots \dots (11)$$

The inner load  $I_2$  vibrates in the same period and as an anti-node between the two nodes, and the torsional rigidity of the shaft is evidently the sum of the torsional rigidities of the shaft between the two nodes, viz. —

$$C = N \left( \frac{J_1}{l_1 - x} + \frac{J_3}{l_3 - y} \right)$$

hence

$$n = \frac{1}{2\pi} \sqrt{\frac{N}{I_2} \left( \frac{J_1}{l_1 - x} + \frac{J_3}{l_3 - y} \right)} \dots \dots \dots (12)$$

Eliminating  $x$  and  $y$  from the equations (12) and (11) and reducing, we arrive at the form (10), where  $n_1, n_3, n_1',$  and  $n_3'$  have the values given above. The two roots indicate two possible modes of vibration: one is a two-node vibration, in which the end loads  $I_1$  and  $I_3$  are always turning in the same direction as each other, and the inner load  $I_2$  in the opposite direction; the other is a single-node vibration, in which the end load nearest to that node turns in one direction, while the inner load  $I_2$  and the other end load turn in the opposite direction.

Other cases,<sup>1</sup> together with some numerical examples, and a very simple method of obtaining frequency equations such as (10), will be found worked out in a paper by Chree, Sankey, and Millington, in the *Proc. Inst. C.E.*, vol. clxii. Also in a paper by Frith and Lamb in the *Journal of the Inst. of Elec. Eng.*, vol. xxxi. p. 646.

EXAMPLE 1.—A gas engine has two flywheels, each weighing 800 pounds and having a radius of gyration of 30 inches, placed 28 inches apart and equidistant from the crank on a shaft 3 inches diameter. Estimate the natural frequency of torsional oscillations. Take  $N = 12 \times 10^6$  pounds per square inch.

The moment of inertia of the crank and attached masses would

<sup>1</sup> See an article by the Author on "Critical Speeds for Torsional Vibrations" in *Engineering*, vol. xc., December 9, 1910.

usually be so small compared with that of the flywheels as to be nearly negligible. In this case, since the node occurs at the crank, it is entirely negligible. The frequency is evidently the same as that of a single wheel on a shaft 14 inches long, fixed at the unloaded end. From (3) this frequency is—

$$n = 3400 \times 9 \sqrt{\frac{1}{800 \times 900 \times 14}} = 9.65 \text{ per second}$$

or 579 per minute.

Speeds in the neighbourhood of  $\frac{1}{2}$ ,  $\frac{1}{3}$ ,  $\frac{1}{4}$ , or  $\frac{1}{5}$ , etc., of the above frequency might give undesirably large torsional oscillations.

**EXAMPLE 2.**—A shaft 4 inches diameter carries a flywheel weighing 1200 pounds, the radius of gyration of which is 18 inches, and a dynamo armature, the moment of inertia of which is  $\frac{3}{4}$  that of the flywheel, the distance between the flywheel and armature being 28 inches. Estimate the frequency of natural torsional oscillations. Take  $N = 12 \times 10^6$  pounds per square inch.

The node divides the length of 28 inches in the ratio 4 to 3, and is  $\frac{2}{7}$  of 28, or 12 inches from the flywheel. Hence, from (7) or (3), Art. 167—

$$n = \frac{3400 \times 16}{\sqrt{1200 \times 18^2 \times 12}} = 25.2 \text{ per second}$$

or 1510 per minute.

#### EXAMPLES XIV.

1. If a closely wound helical spring made of wire  $\frac{1}{4}$  inch diameter has 10 coils, each 4 inches mean diameter, find the frequency of the free vibrations when it carries a load of 15 pounds. ( $N = 12 \times 10^6$  pounds per square inch.)

2. A steel wire 3 feet long and  $\frac{1}{10}$  inch diameter is fixed at one end and carries at the other a short cast-iron cylinder 8 inches diameter, with its axis, which is 1 inch long, in line with the axis of the wire. Find the frequency of the natural torsional oscillations of the cylinder, the weight of cast iron being 0.26 pound per cubic inch, and  $N$  for steel being  $12 \times 10^6$  pounds per square inch.

3. A steel bar 1 inch wide and 2 inches deep is freely supported at two points 3 feet apart, and carries a load of 400 pounds midway between them; find the frequency of natural transverse vibrations, neglecting the weight of the bar. ( $E = 30 \times 10^6$  pounds per square inch.)

4. If the load in problem No. 3 is uniformly spread over the span, find the frequency.

5. If the bar in problem No. 3 carries 400 pounds midway between the supports and 400 pounds uniformly distributed, find the frequency.

6. If the load in problem No. 3 is placed 9 inches from one support, find the frequency of natural transverse vibrations.

7. Find the whirling speed of an unloaded steel shaft  $\frac{1}{2}$  inch diameter and 4 feet long, assuming the bearings at its ends do not fix its direction there. ( $E = 30 \times 10^6$  pounds per square inch.)

8. Estimate the critical speeds of a shaft  $\frac{1}{2}$  inch diameter and 15 inches long, (a) unloaded; (b) when it carries at its centre a load of 24 pounds; (c) when the central load is equal to its own weight, assuming in each case

that the end bearings do not fix the direction of the shaft. (Weight of steel, 0.28 pound per cubic inch.)

9. Find the maximum bending stress in the (vertical) shaft in problem No. 8 (*b*), when the speed is 0.95 of the critical speed, the load being 0.001 inch out of balance.

10. Find the natural frequency of transverse vibrations of the shaft in problem No. 7 when rotating at 800 revolutions per minute.

11. A six-cylinder oil engine has a crank shaft  $3\frac{1}{2}$  inches diameter. If two fly-wheels, each weighing 1100 pounds and having a radius of gyration of 17 inches, were placed at opposite ends of the shaft, the equivalent length between them being 6 feet 8 inches, find the frequency of a free torsional vibration.

12. A gas engine has two fly-wheels, each weighing 1350 pounds and having a radius of gyration of 25 inches, placed 26 inches apart on a shaft  $3\frac{1}{4}$  inches diameter. Find the frequency of natural torsional vibration.

## CHAPTER XV.

### TESTING MACHINES, APPARATUS, AND METHODS.

**168. Testing Machines.**—Machines for testing pieces of material to destruction vary greatly in principle and in detail, and to do justice to their construction and use would require a separate volume; in this chapter a brief description of a few simple types for particular purposes will be given. For further information the reader is referred to works on Testing,<sup>1</sup> original papers, and the technical press.

In English machines of considerable size, adaptable for various purposes, the straining is often accomplished by means of hydraulic pressure acting on a plunger; in American<sup>2</sup> machines the usual method of straining is by power-driven screw gearing; the same plan is used in this country for smaller machines worked by hand, and latterly for larger power-driven machines. The load or force exerted on the test piece by the machine is usually measured or "weighed" by a movable counterpoise and a lever, or system of several levers, but sometimes the force is measured by fluid pressure on a metallic diaphragm. Perhaps the commonest type of large testing machine in Great Britain is that having a single lever or steelyard for weighing the load; this, and one compound lever machine, will now be described and illustrated.

#### **169. Typical General Testing Machines.**

*Vertical Single-Lever Testing Machine.*<sup>3</sup>—Figs. 207, 208, and 209, are diagrams showing the principle and most important parts of a Wicksteed 50-ton vertical single-lever testing machine, details being omitted.

*Tension.*—Fig. 207 shows a side elevation of the machine in use for a tension test. When there is no pull on the test piece T, the travelling counterpoise or jockey weight P being at zero of the scale, the beam is just balanced on its knife-edge fulcrum F, which rests on a hardened seating on the top of the main standard S. In this machine the straining is accomplished by admitting high pressure water through a controlling valve to a steel hydraulic cylinder H, the ram of which is rigidly

<sup>1</sup> See Unwin's "Testing of Materials," or Popplewell's "Materials of Construction"; or for Continental machines see Marten's "Handbook of Testing."

<sup>2</sup> For descriptions of American machines see Johnson's "Materials of Construction."

<sup>3</sup> For descriptions see a paper on an electrically controlled machine in the *Proc. Inst. Mech. Eng.*, 1907; a paper on an older type in *Proc. Inst. Mech. Eng.*, 1882 and 1891, and a description in *Engineering*, 1896.

attached to a crosshead A. When the crosshead A is driven down the pull is transmitted through the two long screws to the crosshead C

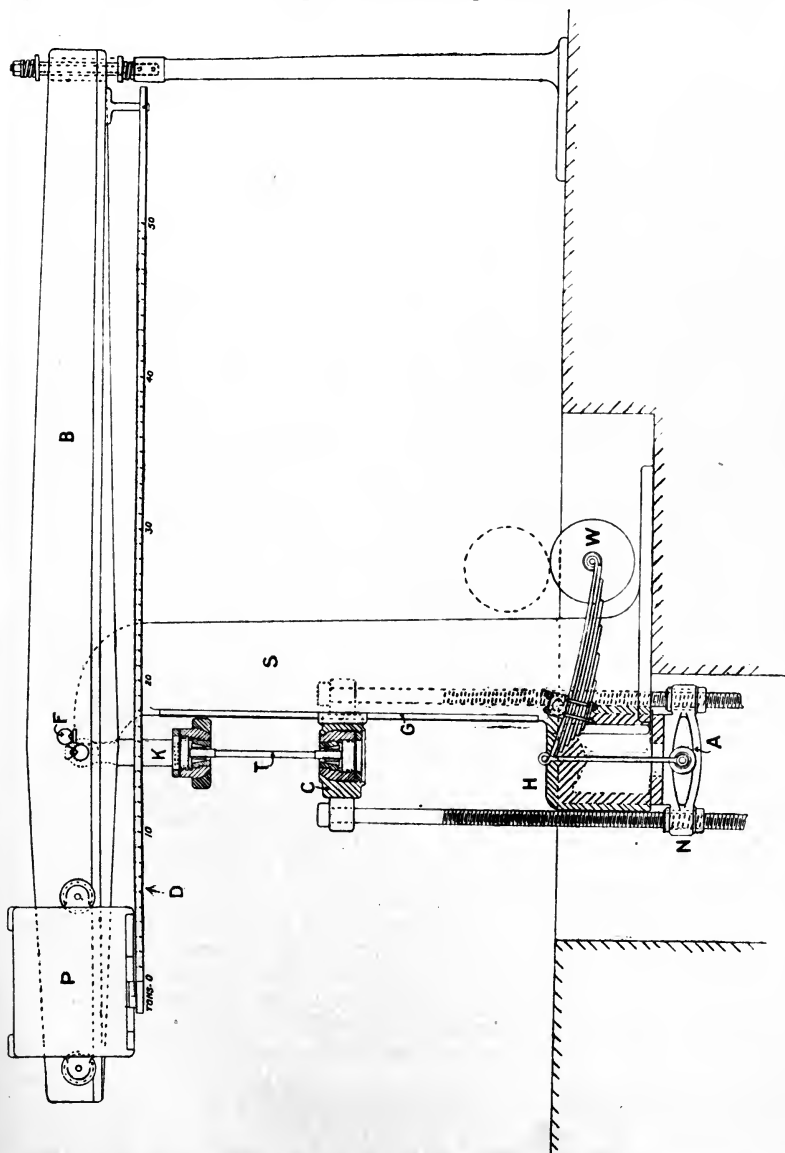

FIG. 207.

(which travels on guides G), to which the lower end of the test piece T is attached by various means described in Art. 170. The upper end of

the test piece is similarly attached to a shackle K, which hangs from a knife edge fixed in the main lever or beam B. As the pull in the test piece is increased by the straining cylinder H, the balance of the main lever is maintained by running the poiseweight P to the right; the load on the specimen is thus weighed as in an ordinary steelyard. The position of the travelling weight P is indicated by a scale D, graduated in tons and tenths of a ton, and read by a vernier on P to  $\frac{1}{100}$  of a ton. The poiseweight P in the 50-ton machine weighs 1 ton, and the knife edge from which the shackle K is suspended is 3 inches from the fulcrum F, hence P must be moved 3 inches for each ton increase of pull in T. The method of moving the poiseweight is not shown in Fig. 207; very frequently the traverse is effected by a long screw within the beam driven by belting. This method is shown in Fig. 211; the power is transmitted to the short end of the beam through a shaft connected to a shaft in fixed bearings by a double Hooke's joint, which allows the beam to move freely parallel to a vertical plane, about its horizontal knife edge F. For very rapid traversing of the poiseweight a hydraulic cylinder, the ram of which acts through a wire rope, is sometimes fitted. The end of the long arm of the main lever B can move for a distance which is regulated by the upper and lower stops shown; the stops are provided with springs to prevent damage to the beam from shock when a test piece fractures. The ram of the hydraulic cylinder H during the straining of the test piece lifts a heavy balance weight W, which serves to replace the ram in the cylinder when the exhaust valve is opened to release the water. The ram has a sufficient length of stroke for straining purposes, but adjustment of the straining head C to suit the length of specimen is effected by means of the two long screws which are screwed into or out of their sockets N in the crosspiece A; in order that the two screws shall be turned the same amount they are driven by similar worms on the same shaft (which is carried in the crosshead C), and gearing with worm wheels (not shown) attached to the screws just below the crosshead C; the worm shaft is turned by a handle in front of the machine.

*Compression.*—Fig. 208 shows a side elevation of the machine in use for compression, the beam being omitted. The upper end of the test piece T is pressed down by the action of the hydraulic ram transmitted through the screws to the straining head C, and applied to the test piece by a flat plate. The lower end of the test piece rests on a flat plate on a small platform L, which transmits the downward force to the shackle K by four long detachable bars E. Similar long bars are shown attaching a platform to the top shackle of the hand-power machine in Fig. 210. When these long bars are in use, owing to the extra weight on the shackle K the beam does not balance when there is no force exerted on the test piece, and the poiseweight P is at the zero of the scale; this zero error must then be subtracted from all subsequent readings.

*Bending.*—Fig. 209 shows a front and a side elevation of the machine applied to a bending test. The beam V to be tested rests on supports Q, the distance apart of which on a very stiff cast-iron



beam M is adjustable; M is carried on the platform L suspended from the shackle K by the four bars E; the load is thus weighed by the steelyard B (Fig. 207). The zero error arising from the extra weight of M must be allowed for; the cross-beam M is often left in position for compression tests, unless the greatest possible length of column is to be tested. The front screw connecting A and C, as well as the two front bars E, are shown broken off to make the diagram clearer. The load is

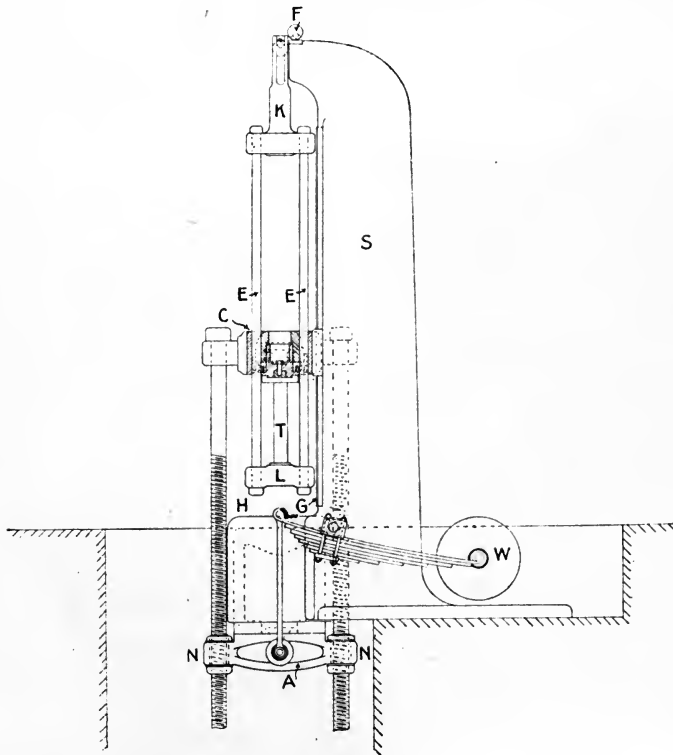

FIG. 203.

applied through a V-nosed piece R on the lower side of the crosshead C. Alternative semi-cylindrical forms of the piece R and the supports Q are shown in Fig. 210.

*Other Single-Lever Machines.*—Fig. 210 shows a 5-ton Wicksteed testing machine adapted to tension, compression, bending, and torsion tests. The straining is in this case effected by a large central screw driven through gearing by hand power applied to the large hand-wheel.

Fig. 211 shows a 50-ton Wicksteed testing machine intended for

tension tests only. The straining takes place by a screw driven through gearing by belting.

A convenient device introduced into the Wicksteed vertical machine is that of alternative fulcrum; the distance between the two knife edges is

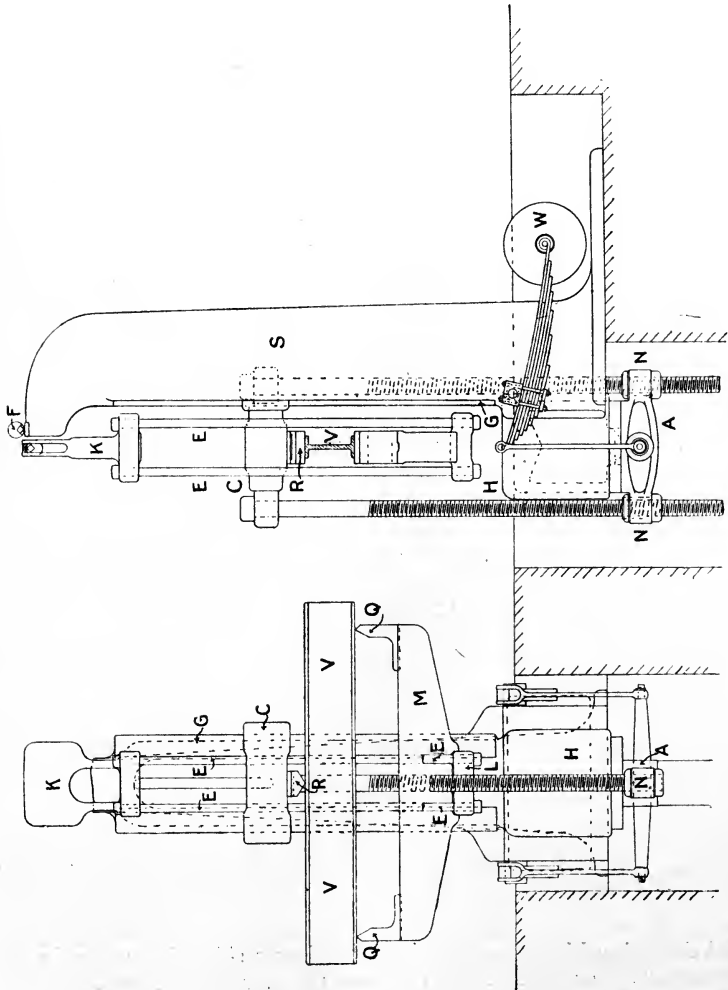

FIG. 209.

made large for use with small and weak specimens, and smaller for stronger pieces; the same travel of the poise-weight may thus represent, say, 25 tons or 100 tons, according to which fulcrum is used.<sup>1</sup>

*Compound-Lever Testing Machine.*—Fig. 212 shows a typical American

<sup>1</sup> For description of changing mechanism, see *Proc. Inst. C. E.*, July, 1891.

testing machine of 100,000 lbs. capacity. The position of a tension test piece is at T, between the straining head C and the fixed head H ;

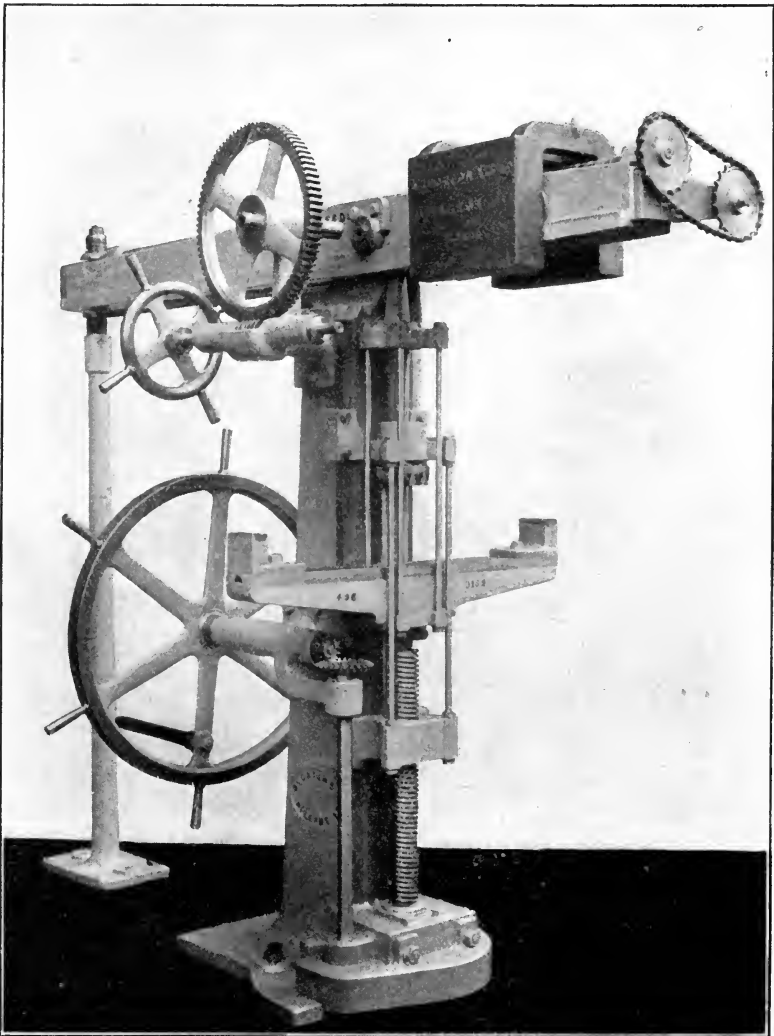

FIG. 210.—5-ton hand-power testing machine.

the crosshead C is driven down by two screws, one of which is shown at S; the power is transmitted to S through spur and bevel gearing,

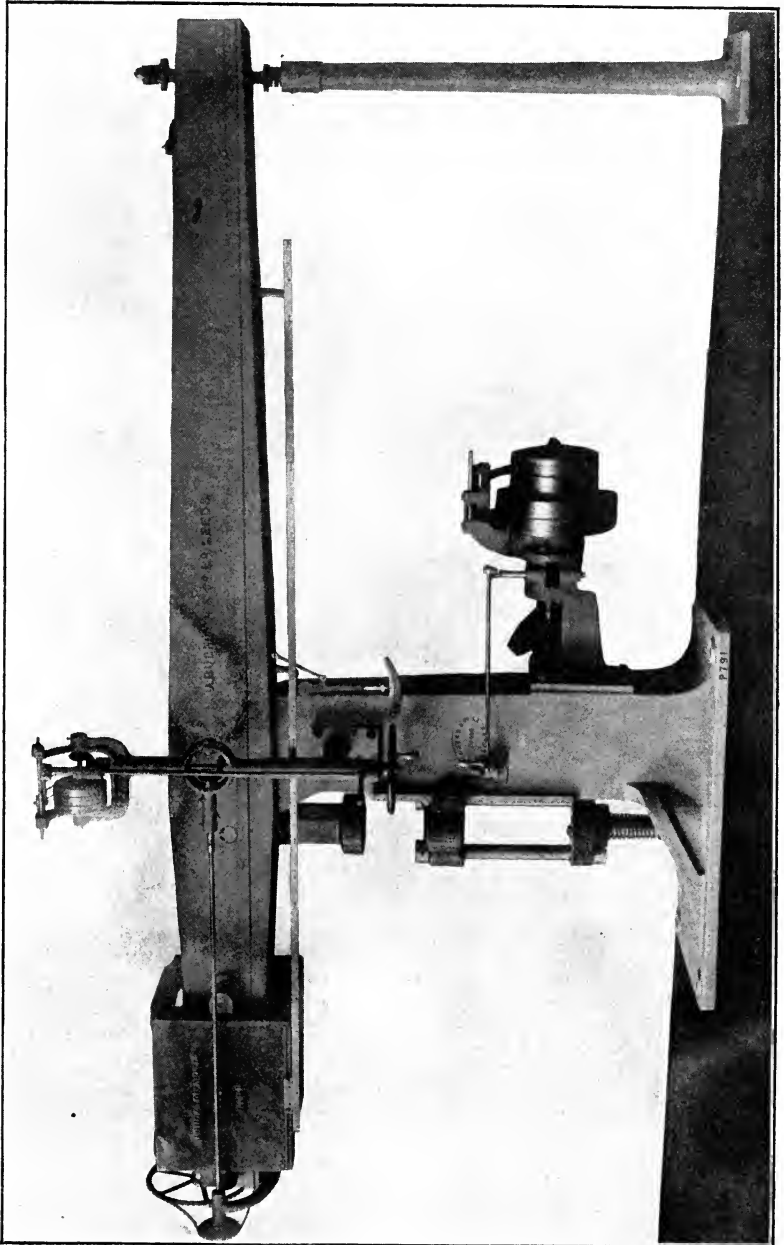

FIG. 211.—50-ton single-lever tension testing machine.

several different speeds being available. Compression tests are made by placing the test piece at  $T'$  between the crosshead  $C$  and the table  $L$ , and machines of this type are made suitable for bending tests by placing

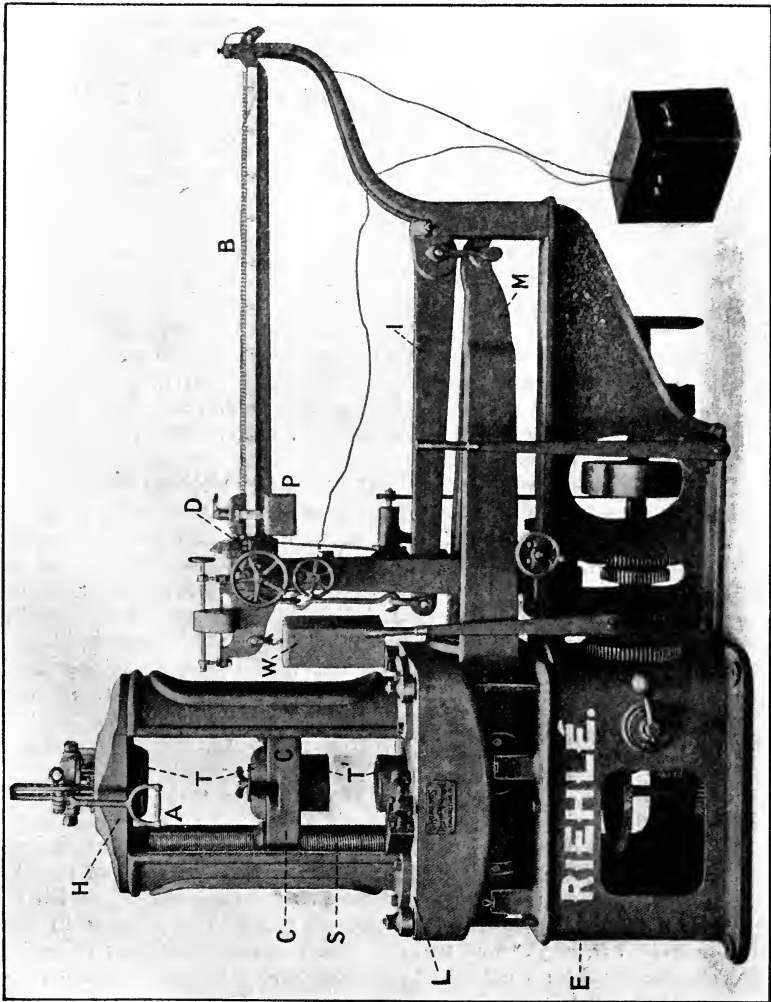

FIG. 212.—Riehlé 100,000-lbs. screw-power testing machine.

the beam supports on the table  $L$  and applying the load from the under side of  $C$ . In all cases the straining force exerted by  $C$  is transmitted through the test piece to the table  $L$ , which rests on knife edges, and is balanced through a system of levers by a comparatively light travelling

poiseweight P, which is moved along the beam B. The poiseweight P is moved outwards along the beam by a screw, driven either by hand from the upper hand-wheel, or by power under electromagnetic control; the position of P is indicated by graduations on the beam, and subdivisions are read either by a vernier on P, or more usually by a graduated dial D rotating with the screw in the beam; the poiseweight can be quickly returned to zero by hand after a test, the driving nut being released from the screw. The main lever M consists of two parts one within the other, each branching into a Y-shape under the table to avoid one of the straining screws, and to spread the points of support, which are knife edges resting in seatings on the main frame E. The table is carried on knife edges in the main lever, the lines of these knife edges passing through the centre lines of the screws S to secure equal distribution of the pressure between the two sets of knife edges in the main levers. The downward pull at the small end of the main lever M is transmitted to a knife edge in the intermediate lever I, and the downward pull at the far end of this lever is transmitted through a link to the beam B, the long end of which is balanced by a counterweight W; the zero reading of the scale can be adjusted by a movable weight shown above W. The bolts shown passing from the main frame E to the table L are to prevent the table jumping in the recoil after fracture of a test piece; the nuts on the top of these recoil bolts rest on spring washers, usually of indiarubber.

#### 170. Tension Tests; Form of Test Pieces and Methods of Gripping.

—The tension test is most commonly adopted as an index of the properties of a ductile metal such as wrought iron and mild steel; the difficulties in and objections to compression tests have been noted in Art. 37. In a commercial test to ascertain whether a sample of material complies with a specification (see Art. 31), the results most usually required are (1) the maximum stress, and (2) the elongation after fracture as a guide to ductility. In addition the stress at the yield point and the contraction of the cross-sectional area (Art. 28) are occasionally required. Observations of the elastic extensions for the determination of the modulus of direct elasticity, the limit of elasticity, Poisson's ratio, etc., although of scientific interest, are practically never required in a commercial test. When required they are made by extensometers (see Art. 174).

The proportion between the length and dimensions of cross-section of test pieces has been dealt with in Art. 27. The ends of ductile tension test pieces are generally gripped by serrated wedges, which fit into recesses in a socket which rests on a spherical seating in the shackle (see Fig. 207) so as to give a pull as nearly axial as possible. The enlarged end for a flat ductile specimen, and serrated wedges suitable for holding it, are shown in Fig. 213. The serrated V-groove wedges and end of test piece in Fig. 214 show a suitable arrangement for round or square pieces of ductile metals—the enlargement of the ends may often be dispensed with in iron and steel bars; these wedges and the spherical seating in the shackle are shown in Fig. 207. In the Riehlé machine shown in Fig. 212 the serrated wedges shown lying on

the table L are rounded on the gripping face to bite most deeply at the middle of the face to secure the axial alignment of the test piece. Each wedge has a handle and can be lifted into or out of its socket by a balanced lever worked from the handle A; different thicknesses of

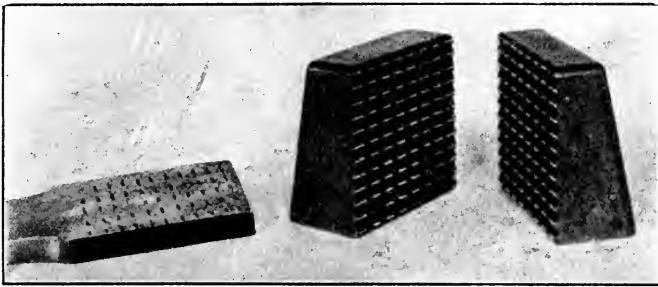

FIG. 213.—Wedge grips for flat specimens.

flat metal are accommodated by the same wedges by the aid of different liners fitting behind the wedges. The screwed socket at A, Fig. 215, shows a common method of holding cast iron and other brittle tension test pieces. The cheese-headed specimen at B, Fig. 215, resting in

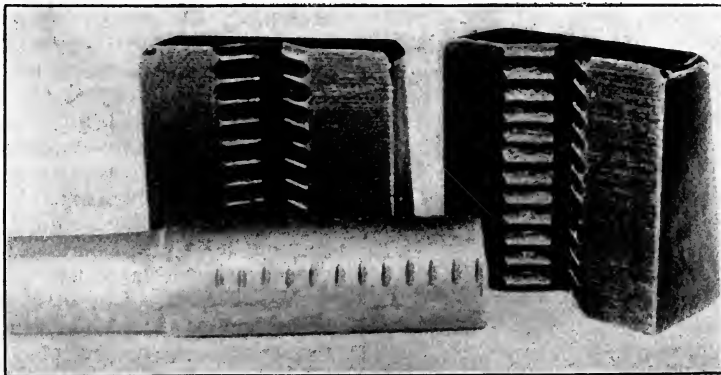

FIG. 214.—Wedge grips for round and square specimens.

split dies, which screw into a larger socket, shows a method applicable to brittle or ductile material; the heads are sometimes made to fit spherical recesses in such split dies to secure axial alignment. When only a small test piece cut out of a casting or forging is available, short

lengths at each end are screwed, and nuts taking the place of heads fit into the recess in the split dies.

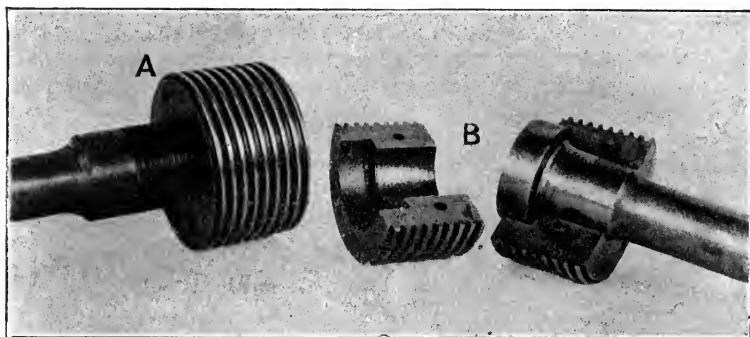

FIG. 215.

**171. Shearing Tests.**—Fig. 216 shows an arrangement by which shearing tests may be made. The specimen A is held firmly between pairs of blocks BB' and CC', and, the testing machine being arranged as for compression tests, pressure is applied through the cap D to the upper cutting block K, which shears the specimen at two cross-sections. A nearly sheared specimen is shown beside the apparatus. The shearing block K and the lower cutting blocks B' and C' are fitted with hard steel cutting edges. As shown in Fig. 216, the apparatus is arranged for use on a round bar. By reversing all the blocks BB', CC' and KK', it can be used for a rectangular or flat test piece.

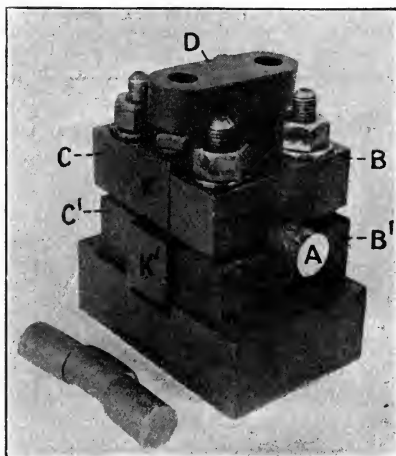

FIG. 216.—Shearing test apparatus.

An alternative form of shearing apparatus is that in which the relative movement of the two parts is obtained by pulling by means of tension shackles, instead of by thrust.

Although tests in such an apparatus may not approximate to a condition of pure shear, there being evidently bending and compression, as well as shear stresses, it may represent the state of stress to which many important elements are in practice subjected. The only method of obtaining "pure" shear is by torsion of a cylindrical test piece, and



in such a case the intensity of shear stress is not uniform, and beyond the limit of proportionality of stress to strain, even its distribution is not accurately known. Many results obtained from an apparatus similar to that in Fig. 216 are, together with an interesting discussion, to be found in a paper by Mr. Izod, in the *Proc. Inst. Mech. Eng.*, January, 1906.

**172. Calibration of Testing Machine.**—The tests to be applied to a testing machine such as the vertical single-lever machine described in Art. 169, to ensure that it is in good working order, are as follows:—

(1) *Zero Error.*—To test whether there is any zero error it is only necessary to place the travelling counterpoise at the zero of the scale and see that the beam is midway between the stops. Any zero error may be corrected by moving the vernier on the travelling counterpoise. In the Riehlé compound-lever machine adjustment can be made by the movable weight above W (Fig. 212).

(2) *Sensitiveness.*—To determine the sensitiveness of the machine the travelling counterpoise or jockey weight may be placed in zero position and weights hung from the upper shackle, or at some other measured distance behind the fulcrum. The greatest weight which may be so hung without causing the beam to move upwards from its position midway between the stops is to be noted. Similarly, the weight hung at a measured distance on the opposite side of the fulcrum, which just causes the beam to move downwards, is to be determined. The sum of the moments of these suspended weights about the fulcrum, divided by the distance between the two knife edges, gives the possible error in the reading due to want of sensitiveness. The test might be performed with a single observation by hanging the greatest possible load on the beam at some point on the opposite side of the fulcrum to the shackles, without causing the beam to move downwards, and then finding what load may be hung on the shackle without moving the beam upwards. The error due to want of sensitiveness may be actually greater at heavy loads than at zero load at which the test is made, but *proportionally* to the pressure on the knife edge it will probably be less. Want of sensitiveness arises from wear, causing bluntness of the knife edges or grooves in the seatings on which the knife edges rest.

(3) *Weight of the Movable Counterpoise.*—This may be found by balancing the beam with no extra load on the shackles, and then running the counterpoise a measured distance behind or in front of the zero of the scale, and balancing again by hanging weights on the beam at a measured distance from the fulcrum. The weight of the counterpoise is then equal to the suspended weight multiplied by the ratio of its distance from the fulcrum to the distance the counterpoise has been moved from the zero mark.

(4) *Distance between Knife Edges.*—The determination of the distance from the fulcrum to the knife edge from which the top shackle hangs, other than by direct measurement, is a troublesome operation. It is necessary, after balancing the beam with the counterpoise at zero, to hang from the shackle a heavy weight (at least half a ton, and preferably more), and then to run the counterpoise forward until a balance is again obtained. The distance between the knife edges is then equal to the

distance the counterpoise has been moved forward from zero, multiplied by the ratio of the weight of the counterpoise to that in the shackle.

**173. Torsion Testing Machine.**—Fig. 217 shows a very simple form of torsion testing machine. One end of the test piece *T* is keyed to a worm-wheel *W*, which is driven through a worm by a hand-wheel *H*. The other end is keyed to a bracket attached to a horizontal lever *L*, balanced on knife edges resting on hard steel seatings on the frame, and in line with the axis of the test piece. The twisting

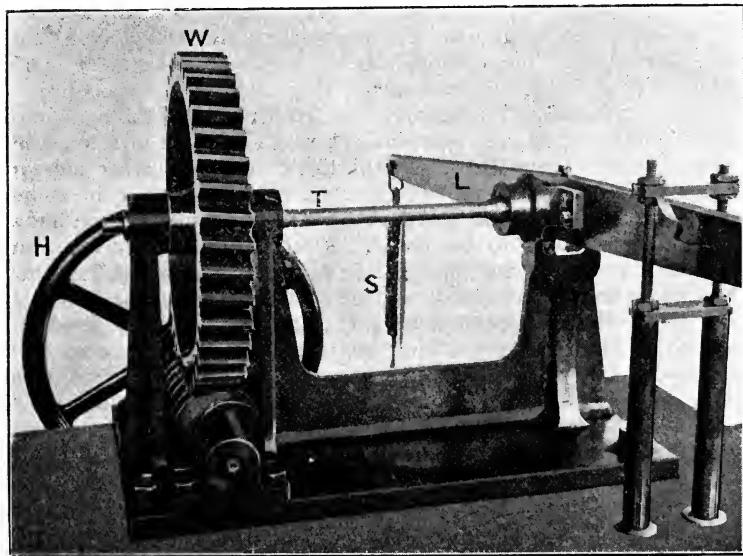

FIG. 217.—Torsion testing machine, 6000 lb.-inches capacity.

moment applied to the test piece is measured by the pull on spring balances attached to knife edges at opposite ends of the lever *L*, which remains horizontal, any deviation due to the pull on the balances being corrected by adjusting screws. The capacity of the machine illustrated is 6000 lb.-inches, which is sufficient to break a mild-steel specimen  $\frac{3}{4}$  inch diameter.

More elaborate torsion machines differ from this one mainly in that the twisting moment is measured by a jockey weight moving over a graduated scale on the lever. The addition of a worm and worm-wheel torsional straining arrangement on a side bracket is often made to a single-lever tension testing machine, thus enabling it to be used as a torsion testing machine. An example of this arrangement is shown in the 5-ton hand-power machine (Fig. 210), which has a capacity of 2000 lb.-inches for torsion tests.

*Form of Test Piece.*—Fig. 218 shows a common form of torsion test piece, the ends being enlarged and having one or two keyways to secure

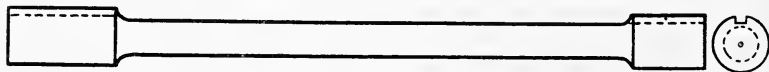

FIG. 218.—Torsion test piece.

the specimen to the worm-wheel or other straining gear, and to the lever. Fractured torsion test pieces of cast iron (in front) and mild steel (behind) are shown in Fig. 219.



FIG. 219.—Torsion fractures.

**174. Extensometers.**—Except in the case of very long specimens, the elastic extensions are too small for direct measurement, and special instruments are used for such work. A great amount of ingenuity has been spent on the design of such instruments, and a large number of different kinds are in use. A review of the various types, with references, is to be found in a paper on the Measurement of Strains, by Mr. J. Morrow, in the *Proc. Inst. M.E.*, April, 1904.<sup>1</sup>

Beyond the elastic limit the larger strains of ductile material between centre dots may conveniently be measured by a pair of dividers.

*Goodman's Extensometer* (Fig. 220).—In this instrument the movement apart of two points on the test piece is multiplied by a lever. The two clips *CC'*, which form part of the frame of the instrument, are attached to the test piece *T* by screws with hardened steel points, which enter the test pieces, the pairs of centres being generally 10 inches apart. The remainder of the frame *F* is made of light brass tubing, and, although not hinged, has sufficient flexibility for the clips to spring apart for about  $\frac{1}{2}$  inch beyond the gauged distance without damage; as the extreme measurement is about  $\frac{1}{20}$  inch, this amount of play is sufficient. Two pillars, *KK'*, are attached to the clips *CC'*, the upper one by a steel strip, and the other one rigidly. The free ends of the pillars *KK'* have *V*-grooves, which engage with two horizontal knife edges firmly held at a fixed distance apart in a brass piece *B*, attached to which is the long, light, wooden pointer *P*. When the test piece

<sup>1</sup> For an experimental comparison of extensometers of different types, see *Report of the British Assoc.*, 1896; and for very sensitive instruments, see "An Interference Apparatus for Calibration of Extensometers," *Phil. Mag.*, Jan. 1905.

T stretches, the V-grooves in K and K' recede from each other, and consequently P tilts, and its point moves downward over the scale S, which is clipped to the tube E, which forms part of the frame. After attachment of the instrument to the test piece, the points may be brought to zero or elsewhere by the adjusting screw A, which also allows of the instrument being used over a somewhat greater range than that given by the scale. The motion of the end of the pointer P is 100 times that between the screw points. The instrument is calibrated by noting the

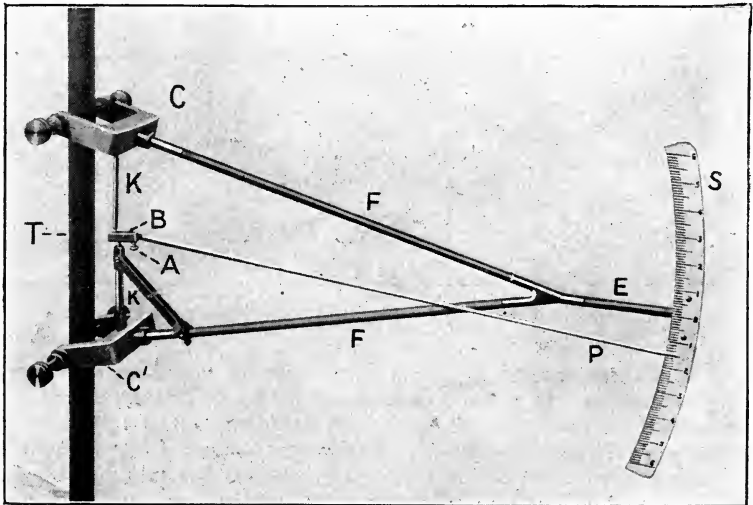

FIG. 220.—Goodman's extensometer.

travel of the pointer over a large part of the full stroke for a motion of the clip points, which is determined by a measuring machine. The final adjustment may be made by fixing the length of the pointer P and the position of the scale S on the tube E. A gauge (not shown) which fits over the set screw shanks, facilitates the fixing of this handy instrument on the specimen, so that the length over which extension is measured is exactly the required amount, usually in this instrument 10 inches.

*Ewing's Extensometer* (Fig. 221).—Two clips, C and C', grip the test piece A by means of set screws with hardened steel points, the two pairs being usually 8 inches apart. A bar, B, rigidly attached to the lower clip C', of which it forms a part, has a rounded point, which engages with a conical hole in the end of a well-fitting screw S, in the upper clip C. On the side opposite to B a light bar B' hangs from the upper clip C, its upper end resting in a conical hole, and its lower end passing freely through a guide in the clip C'; the hanging bar B' is kept in position by a long, light spring (behind B' in Fig. 221) attached to C, and

by the guide in  $C'$ . When the test piece  $A$  stretches, the clip  $C$  turns, parallel to a vertical plane, about the rounded end of  $B$  as a pivot, and the hanging bar  $B'$  is raised relatively to the clip  $C'$ . The centres of the rounded ends of  $B$  and  $B'$  are usually equidistant from the gripping points, hence the movement of  $B'$  relative to  $C'$  is equal to twice the extension of  $A$ . This relative motion is measured by observing a wire stretched across a hole in the lower end of  $B'$  by means of a microscope  $M$ , the eye-piece of which has a scale; observations are made of one *edge* of the thick wire as it appears on the scale. The scale is divided into 140 parts, each of which represent  $\frac{1}{5000}$  inch extension between the pairs of gripping points when the microscope is

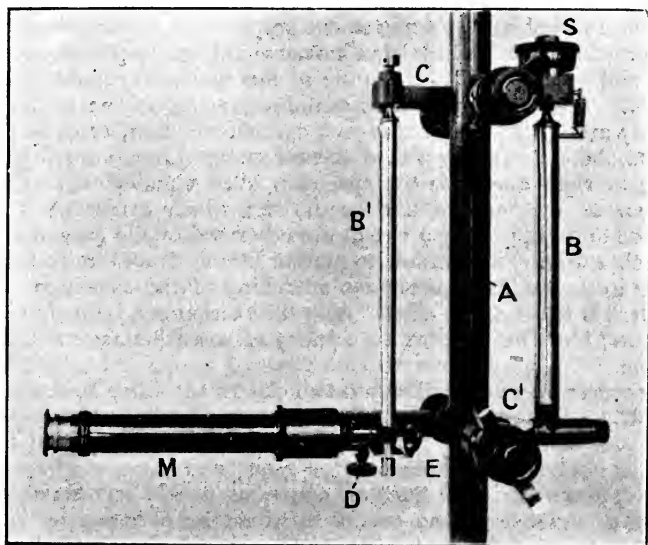

FIG. 221.—Ewing's extensometer.

in correct adjustment, estimations to  $\frac{1}{10}$  of a division giving a reading to  $\frac{1}{50000}$  inch.  $D$  is a means of adjusting the cross-wire in focus, and  $E$  is an illuminating mirror. When detached from the test piece, the instrument is held together by a clamp fastened on to conical seatings on the clips  $C$  and  $C'$  by the large winged nuts shown. The calibration of the instrument is performed by observing the movement of the wire over the scale while one complete turn is given to the screw  $S$ , which has fifty threads per inch; this should cause the wire to traverse 50 of the 140 scale divisions,  $\frac{1}{50}$  inch movement of the socket being equivalent to  $\frac{1}{100}$  inch extension.

An extensometer recently introduced (1908) employs a principle of magnification similar to Ewing's, but measurement of the motion is made

by a micrometer screw, which is turned until its point makes contact with a piece of metal attached to a spring piece or tongue, which vibrates perpendicular to the micrometer screw.<sup>1</sup>

*Measurement of Elastic Compression.*—Professor Ewing's extensometer in a modified form is used for the measurement of compressive elastic strains. The distance of the hanging bar corresponding to B', from the axis is 9 times that of the rigid bar corresponding to B, so that the strain is then multiplied 10 times, instead of only twice as in the longer tensile specimens; the length over which compressive strain is measured is  $1\frac{1}{2}$  inch.

**175. Autographic Recorders.**—Various attempts have been made to devise an apparatus for obtaining a continuous and accurate record of the stress and strain throughout a tension test. An apparatus consisting of a pencil having a movement proportional to the stress, over a paper or other surface which has a movement at right angles to that of the pencil, and proportional to the strain of the specimen, would give such a record. The necessary motion of the paper proportional to the strain is readily arranged by placing it on a cylindrical drum, which is caused to rotate about its axis by a cord or wire wrapped round the drum and passing at right angles to the specimen over a pulley clipped to the specimen at one end of the length over which extension is to be measured and gripped by a clip at the other end of the gauged length; with such a driving apparatus, no motion of the drum results from the slipping in the wedge grips or from stretching of the specimen outside of the length between the clips. Also the motion can be multiplied by connecting the wire or cord to a pulley of small diameter attached to the drum.

Recorders may be divided into two classes according to the manner in which the motion proportional to the stress is obtained.

(1) *Semi-Autographic Recorders.*—In this class the motion of the pencil is obtained by connection or gearing of some kind from the travelling jockey weight. Such an apparatus merely records automatically as a curve the same results as would be obtained by isolated measurements, and the record is only correct so long as the lever of the testing machine "floats" between its stops; when it rests on a stop, the position of the jockey weight is no indication of the stress. A description of such an apparatus will be found in Unwin's "Testing of Materials."

(2) *Fully Autographic Recorders.*

*Wicksteed's Hydraulic Recorder.*<sup>2</sup>—In this apparatus the water under pressure in the hydraulic cylinder which takes up the strain is also admitted to a small cylinder, where it acts on a ram and compresses a helical spring. The compression of the spring is taken as a measure of the stress on the specimen. The friction of the ram in the recorder cylinder is almost entirely eliminated by rotating the ram. The friction of the packing of the main ram of the testing machine is taken as proportional to the pressure, and as therefore affecting only the scale of the

<sup>1</sup> See *Engineer*, May 15, 1908.

<sup>2</sup> See *Proc. Inst. Mech. Eng.*, 1886.

diagram, which is determined by marking on the autographic diagram some points from the scale-reading of the jockey weight while the lever is floating between its stops.

*Kennedy's Autographic Recorder.*<sup>1</sup>—In this apparatus the diagram is taken on a flat piece of smoked glass, which receives a multiplied motion from the strain of the test piece between two clips. The motion of the tracing point is obtained from the strain of a larger tension piece which is pulled in series with the actual test piece, but has so large a cross-section as not to reach its elastic limit; its strain is therefore proportional to the stress applied. The motion so obtained is used to turn a roller of small diameter, attached to which is a long pointer having the tracing point at its end; the tracing point moves in an arc instead of a straight line. In using this apparatus the travelling jockey weight may be placed at a point on the scale beyond the maximum load of the specimen. The instrument may be calibrated by finding the travel of the tracing point for a movement of the jockey weight between different points on the scale when the large spring piece is being pulled and the beam is floating between the stops.

*Goodman's Autographic Recorder.*<sup>2</sup>—The motion of the pencil proportional to the stress in the test piece is in this apparatus obtained from the change in the elastic strain in the main standard of the testing machine. A vertical rod several feet long is rigidly attached at its lower end to the standard; its upper end is connected by means of a knife edge with the short end of a compound lever, the fulcra of which are knife edges resting on seatings rigidly attached to the standard; from the end of this compound lever the multiplied motion is transmitted by a fine wire to a carriage fitted with a marking pen. To avoid the effects of friction, the cylindrical rods which guide the pen carrier are rotated by means of a gut band from the driving shaft of the testing machine.

*Gray's and Wicksteed's Spring Autographic Recorders.*—In Gray's autographic recorder (Fig. 222), fitted to the Riehle testing machines, the movement proportional to the stress is obtained from the stretch of a calibrated vertical spring attached below the end of the long arm of the weigh-beam so as to prevent the beam reaching the upper stop when the test piece is pulled. In this apparatus the jockey weight remains at the zero of the scale throughout the test, and the spring or "stress" movement is employed to turn the drum to which the diagram paper is fastened; various amounts of magnification of the movement of the end of the beam being obtained by different sizes of pulleys on the drum; the pencil movement is caused by the strain of the test piece, the motion being multiplied by levers, a much greater multiplication being used during the elastic extension than in the subsequent stages. The rod shown in Fig. 222 connecting the clamps on the specimen to the smaller-framed lever, which gives the higher multiplication, is provided at its top end with an adjustment permitting the high multiplication to be used for considerable strains, the pencil being repeatedly brought

<sup>1</sup> See *Proc. Inst. Mech. Eng.*, 1886.

<sup>2</sup> For a full description and illustrations, see *Engineering*, Dec. 19, 1902.

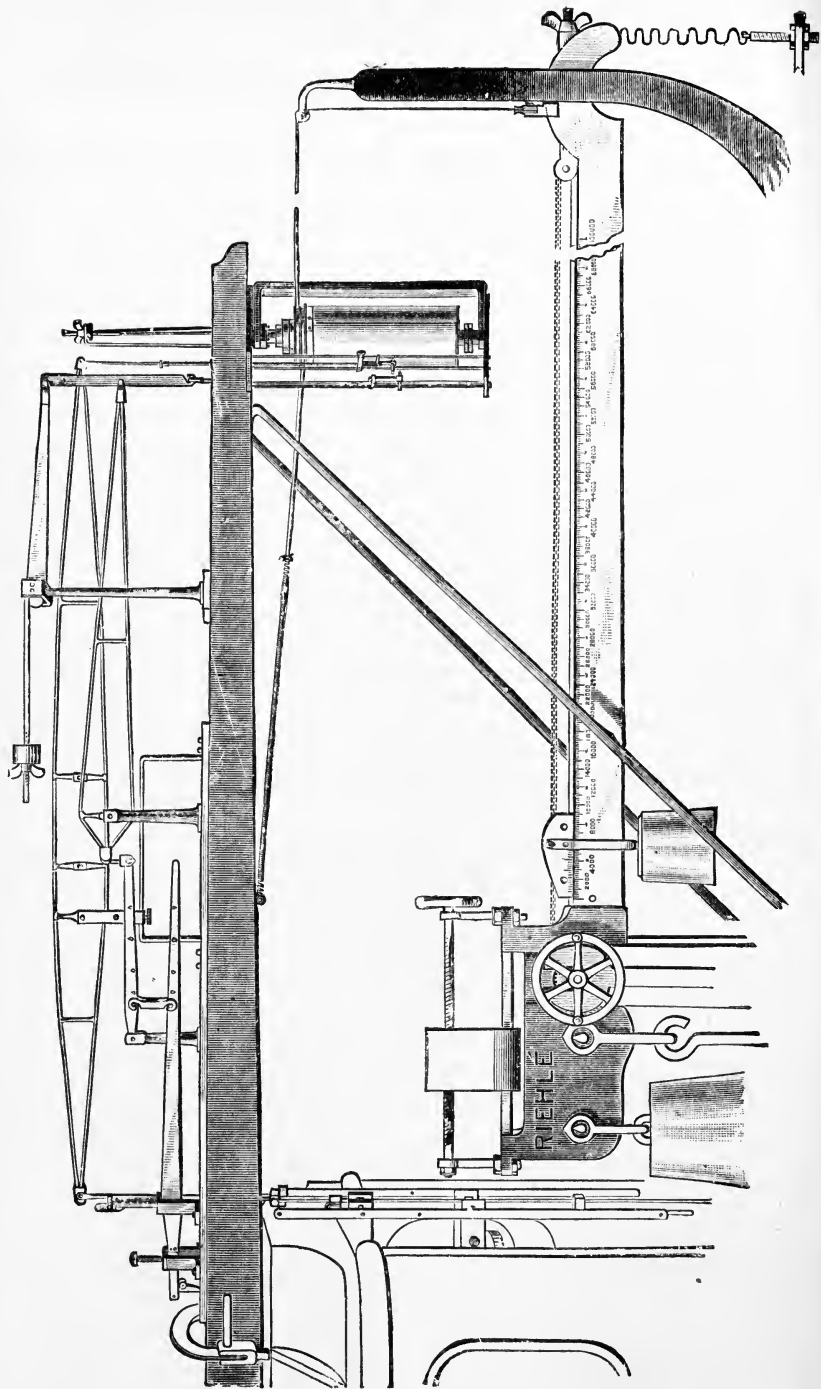

FIG. 222.—Gray's autographic spring recorder.



back to the zero to avoid passing off the cord. The longer-framed lever, which gives the lower multiplication suitable for strains beyond the elastic limit, is provided with three alternative fulcra, giving magnifications of strain suitable for different materials and gauge lengths. Similarly, five alternative positions of the detachable link in the other train of levers give five multiplications from 100 to 500 for the elastic portion of the curve. The spring can be calibrated by loading a steel specimen of so large a cross-section that the elastic limit is not reached, and balancing its pull by the jockey weight in a definite position, then running the jockey weight to zero on the scale, attaching the spring and noting the revolution of the drum when the same pull is balanced by the spring, the beam being brought to the same position again.

In using the Wicksteed autographic spring recorder (Fig. 222a)

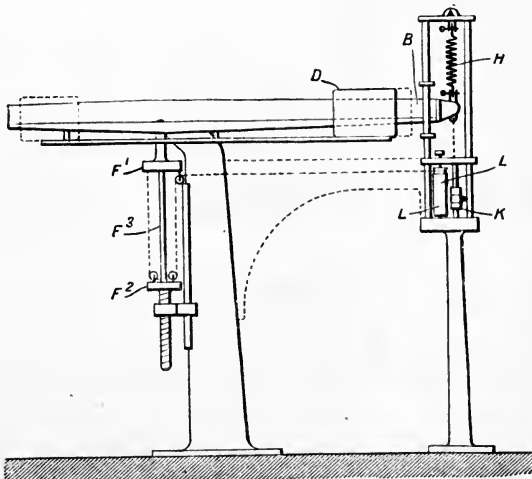

FIG. 222a.—Wicksteed's autographic spring recorder.

(From "The Engineer.")

the jockey weight D is first placed at a point on the scale beyond the breaking load of the test piece F<sup>3</sup>. The beam B is supported and prevented from reaching the *lower* stop by means of a helical spring, H, in tension, placed above the end of the long arm of the beam. As the tension is applied to the test piece by the straining apparatus, the spring is relieved from stress by an amount which is proportional to the tension in the test piece, and the helical spring shortens by a proportional amount. This movement of the spring and the end of the beam is employed to move a tracing point on a carrier, K, over the surface of the drum L parallel to its axis, while the drum is rotated by the motion derived from the strain of the test piece between a clip F<sup>1</sup> and a pulley at F<sup>2</sup> at a fixed distance apart. The spring can be calibrated and the diagram graduated by noting the movement of the pencil caused by a given movement of the jockey weight.

*Autographic Diagrams.*—The autographic diagram offers no advantage over ordinary measurements for the determination of the ultimate strength, elongation, etc. By its use, however, it is possible to trace out the relations of stress and strain qualitatively at least, and with fair accuracy quantitatively, in circumstances where ordinary measurements are difficult or impossible, *e.g.* in the neighbourhood of a yield point and during the local extension which takes place just before fracture in a ductile metal. It is also possible by the autographic diagram to investigate the effects of various speeds of tensile straining, and cases where extension takes place discontinuously at intervals under a regularly increasing load.

**176. Measurement of Beam Deflections.**—The elastic deflections of a long beam may often be measured directly by a pair of vernier calipers, or by clamping a vernier to the beam so as to move over a fixed scale. In the case of a stiffer beam the elastic deflections may be measured by attaching a finely divided glass scale or a cross-wire to the beam and observing its movement through a reading microscope, or by multiplying the motion by a lever. An arrangement for multiplying the motion by a simple lever is shown in Fig. 223; if a vernier is added to the pointer of such an instrument with a leverage of 10 to 1, deflections

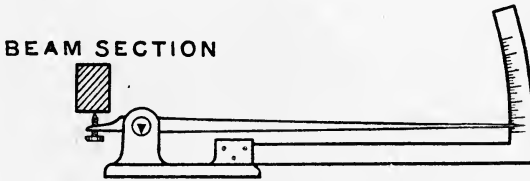

FIG. 223.—Deflection measuring apparatus.

can easily be measured correctly to  $\frac{1}{1000}$  inch, and this is generally sufficiently accurate. To eliminate any possible yielding of the supports of the beam, the socket in which the knife edge of the multiplying lever rests may be suspended by clips (such as those shown in Goodman's extensometer, Fig. 220) from the beam, the points gripped being preferably in the neutral plane. To record correctly the deflection of the neutral surface it may also be desirable to actuate the short end of the lever by a clip attached to points in the neutral surface, instead of by the lower surface of the beam as shown in Fig. 223.

**177. Measurement of Torsional Strain.**—Fig. 224 shows an apparatus devised by Prof. E. G. Coker for the measurement of torsional strain.<sup>1</sup> In this instrument the elastic twist of a specimen A over a length of 8 inches is measured by observing the motion of a wire W (as in Ewing's extensometer) through a microscope M, the eye-piece E of which has a glass scale illuminated by the mirror F. The cross-wire W, mirror F, and focussing screw K, are carried on an extension

<sup>1</sup> See *Phil. Mag.*, December, 1898, or *Phil. Trans. Roy. Soc. Edinburgh*, vol. xl. part ii. p. 263.

of an arm B of the vernier plate V, capable of being moved round a finely graduated circular plate G attached by three steel-pointed screws (behind the plate) to the specimen A. A chuck, C, similarly attached by three screws to A, carries an arm D, into the upper part of which the microscope fits. The lower part of the arm D consists of a divided collar, which serves to attach it to the chuck C after the plate G and the chuck C have been centred on the specimen A by the help of a clamp (not shown). The clamp consists of two divided collars, wedge-shaped in section and longitudinally connected, which grip G and C so as to

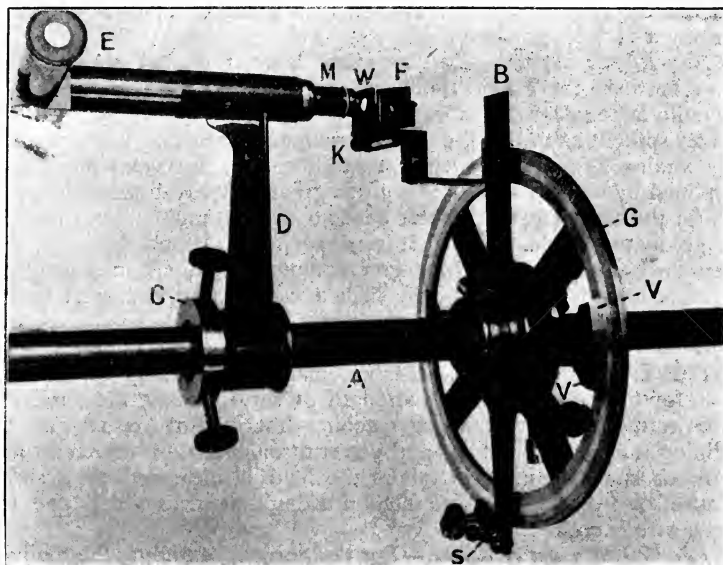

FIG. 224.—Coker's torsional strain measuring apparatus.

form one rigid piece to be centred by the six gripping screws. The lower split end of the arm D then takes the place of one of the divided collars of the clamp on the chuck C. The divided collars of the clamp and the arm D are hinged on one side of the division, and the free ends can be clamped by screws and nuts.

The calibration of the instrument, *i.e.* determination of the value of the divisions of the microscope scale, is effected by turning the arm B carrying the wire W, along with the vernier plate V, by means of the tangent screw S, through a definite angle of, say, 10 minutes of arc over the graduated plate G, the angle being read with the help of the vernier V, assisted by the small magnifying glass shown. The range of measurable strain is evidently not limited to the eye-piece scale, as the wire can be readjusted to zero, after any given angle of strain, by the tangent screw S; the limit of accuracy of readings is about one second of arc.

In the absence of such an instrument as that just described, elastic torsional strains may be measured by observing the movements over fixed scales of two *long* straight pointers clamped to the specimen, and taking the difference. A convenient alternative is to fix a scale to the end of one pointer and a cross-hair and sighting hole, to avoid parallax errors, to the other, and observe the movement of the cross-hair over the scale. Another alternative is to replace the long pointers by mirrors clamped to the specimen so as to reflect radially outwards. The reflection of a fixed scale read by a telescope, or of a cross-wire on a fixed scale, moves through twice the angle turned through by the bar, and moving the point of observation to a great distance is equivalent to using a very long pointer.

*Non-Elastic Strain.*—For the very large torsional strains which occur between the elastic limit, and the breaking load in torsion for a ductile material, the microscope M (Fig. 224) might be replaced by a pointer so bent as to travel over the graduated circle G. For measuring only strains beyond the elastic stage the apparatus may be greatly simplified by substituting for G a circle graduated, say, to whole degrees, and for the microscope a pointer bent so that its point moves close to the graduated circle. Wrought-iron specimens,  $\frac{5}{8}$  inch diameter, may often be twisted through over four complete rotations in a length of 8 inches before fracture, and in such a case readings, correct to one degree, would be of sufficient accuracy for the strains beyond the elastic limit.

**178. Tension of Wires.**—Testing machines of many varieties are made for finding the ultimate strength of wires. Some are similar in action to the single-lever testing machine described in Art. 169, but the straining is accomplished by hand power through a screw driven through worm or spur gearing; in others the load is measured by a spring balance, or by fluid pressure behind a diaphragm, to which one end of the wire is connected.

*Elastic Extension of Wires.*—For the purpose of finding the modulus of direct elasticity of thin wires, hanging weights in a scale-pan forms a convenient method of applying a known load. If the wire is sufficiently long the extensions may be read by clamping to the wire a vernier to move over a fixed scale. A usual arrangement is to hang two wires side by side from the same support, clamping a vernier to one and a scale to the other; one wire carries a constant load to keep it taut, and the other is given regular increments of load for which the extensions are measured. This plan eliminates any error due to yielding of the support or change of temperature, and minimises any trouble due to swinging. It is often necessary to reject the observations from the lower loads, the measured extensions for which represent partly the stretch and partly the effects of straightening the wire.

Instead of using a vernier and scale, a micrometer screw and level may be used as in Fig. 225, which represents Searle's apparatus. When weights are placed in the scale-pan the wire A stretches and lowers the right-hand side of the spirit level L, which is pivoted at P to the frame attached to the idle wire B, and rests on the end of the screw S, which

fits into the frame attached to the wire A; the extension is measured by turning the micrometer screw S, which brings the bubble to the centre of L, and noting the motion of S by means of its graduated head. The frames attached to the two wires are kept from separating by a link C, which turns freely on pins in both frames.

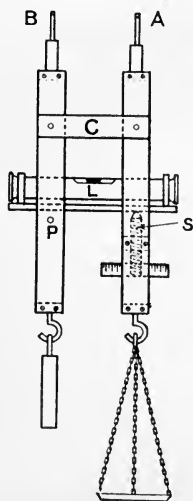

FIG. 225.—Elastic extension of wire.

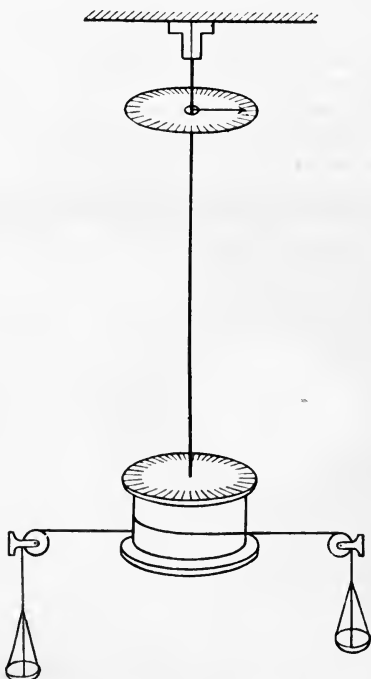

FIG. 226.—Elastic torsion of wire or rod.

The relative motion of two such wires may also be measured by causing it to tilt a mirror. Prof. Ewing has employed this optical method in an apparatus, the magnification of which is so great that wires only about 3 feet long are used.

**179. Elastic Torsion of Wires.**—In order to determine the modulus of rigidity of a wire very simple apparatus may be used, for the torsional rigidity of a long piece of thin wire being very small, large angles of twist are produced by small twisting couples. The usual arrangement applicable to long thin rods is shown diagrammatically in Fig. 226. The upper end of a wire is firmly clamped in a vertical position, and the lower end is clamped to a drum or pulley, to which a couple, having the wire as axis, is applied by horizontal cords passing over pulleys and carrying equal weights in scale-pans. The twist of the lower end of the wire may be measured by the movement past a fixed pointer of a graduated dial attached to the drum, and to avoid any effects of possible slipping in the top clamp a horizontal pointer may be attached to the wire near the upper end; the movement of this pointer over

a fixed dial, subtracted from the angular movement of the lower end, gives the twist in the length between the two points of observation.

*Kinetic Method.*—The torsional stiffness, and hence the modulus of rigidity, may also be obtained by observing the period of torsional oscillation of a mass of known moment of inertia at the free end of a wire fixed at the upper end (see Art. 181).

**180. Bending of Light Beams.**—The bending of a beam of small section to determine the modulus of elasticity, or to find the modulus of rupture (Art. 74), may be accomplished by placing it on supports at each end and hanging loads in the middle of the span. The deflection may

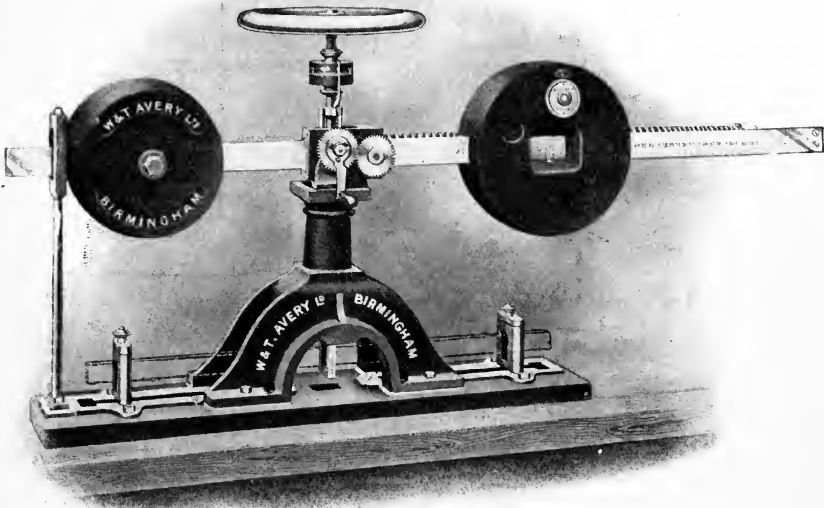

FIG. 227.—Transverse bar-testing machine.

often be determined with sufficient accuracy by direct measurement, or by calipers, or the methods given in Art. 176 may be used. Numerous small single-lever machines are made for transverse tests of bars of small sections, and are used particularly for small cast-iron bars made from the same metal as a larger casting in order to comply with a specification. A common requirement is that a test bar 1 inch wide and 2 inches deep shall have a central breaking load on a span 36 inches between supports of not less than 26 cwts. ; another is that a bar having a section 1 inch square shall have a breaking load of at least 2000 pounds on a 12-inch span. Occasionally some requirement as to the deflection is specified.

Fig. 227 shows a small transverse bar-testing machine made by Messrs. W. and T. Avery for cast-iron foundry bars of sections up to

2 inches deep by 1 inch broad, and lengths up to 36-inch span. The strain is applied by a screw turned by the hand-wheel, which lifts the central socket and puts an upward pull on the beam midway between the two end sockets, and an equal downward thrust on the lever near to the fulcrum. The deflection is measured by the movement of the screw which is observed on the small graduated drum. The load is measured by balancing the lever by the travelling poise, which is driven along it by a screw worked by a handle and gearing. The capacity of the machine illustrated is 40 cwts., which is an ample allowance for breaking a cast-iron test piece of the extreme dimensions given above.

### 181. Experimental Determination of Elastic Constants (Summary).

—In all statical experiments involving measurements of elastic strain for given loads, in order to avoid experimental errors it is desirable to take a series of observations over as large an elastic range of stress as possible. When the observed values of load and strain are plotted as rectangular co-ordinates, correct values will lie on a straight line (according to Hooke's law); by taking the stress and strain by differences between corresponding ordinates of two points on a straight line so plotted, a good experimental result may be obtained, zero errors in particular being avoided.

#### *Young's Modulus (E).*

(1) *Bar of Metal.*—Series of observations of tension and extension by testing machine and extensometer (Arts. 169 and 174).

$$E = \frac{\text{uniform intensity of direct stress}}{\text{fractional extension}} \quad (\text{Art. 9})$$

(2) *Thin Wire.*—See Art. 178. Formula as above.

(3) *Long Thin Bar.*—By flexure due to a central load. This method assumes the correctness of the theory of simple bending in a case where the bending is not "simple," and if E has been previously found by method (1) it becomes a test of the validity of the theory for such a case. Deflections are measured as in Art. 176. Load is applied by hanging weights, or as in Art. 180, Fig. 227.

$$E = \frac{Wl^3}{48I \cdot y} \quad (\text{see (4), Art. 78})$$

where  $y$  is the average difference of deflection for a difference  $W$  of the central load. Cantilevers or other beams may be similarly loaded, and the formulæ of Chapter VI. used to calculate  $E$ .

#### *Modulus of Rigidity (N).*

(1) *Cylindrical Bar of Metal.*—By series of observations of twisting moment and angle of twist by torsion testing machine and torsional strain measuring apparatus (Arts. 173 and 177)—

$$N = \frac{32Tl}{\pi D^4 \theta} \quad (\text{see (3) and (4), Art. 109})$$

where  $\theta$  is the average difference of twist in radians for a difference  $T$  of twisting moment.

(2) *Long Circular-Section Wire or Rod. Statical Method.*—By series of observations of twisting moment and angle of twist, as in Art. 179—

$$N = \frac{32Tl}{\pi D^4 \theta} \text{ (as above)}$$

(3) *Long Circular-Section Wire. Kinetic Method.*—By torsional oscillation of a mass of known (and comparatively great) moment of inertia suspended at the free end of a wire hanging vertically. The mass may conveniently be a hollow or a solid metal cylinder with its axis in line with that of the wire, or a rather long bar of cylindrical or rectangular cross-section with its axis perpendicular to that of the wire and bisected by it. From (2), Art. 167—

$$N = \frac{4\pi^2 n^2 I l}{J} = \frac{128\pi n^2 I l}{d^4} \text{ or } \frac{128\pi n^2 W k^2 l}{12 \times 32 \cdot 2 \times d^4}$$

where  $n$  is the frequency of torsional vibrations per second, and all linear dimensions are in inch units.

Another plan is to first find the frequency  $n_1$  of torsional oscillations of a carrier of unknown moment of inertia  $I_1$ , and then find the frequency  $n_2$  when a mass or masses of known moment of inertia  $I_2$  are placed in the carrier. Then—

$$N = \frac{4\pi^2 n_1^2 I_1 l^3}{J} = \frac{4\pi^2 n_2^2 (I_1 + I_2) l^3}{J}$$

and eliminating the unknown  $I_1$ —

$$N = \frac{n_1^2}{n_1^2 - n_2^2} \cdot \frac{4\pi^2 n_2^2 I_2 l^3}{J} \text{ or } \frac{n_1^2}{n_1^2 - n_2^2} \cdot \frac{128\pi n_2^2 I_2 l^3}{d^4}$$

A convenient form of carrier (which is used to overcome the difficulty of attaching various masses to the wire) is a metal tube into which a metal cylinder ( $I_2$ ) fits. The moment of inertia  $I_2$  is determined by weighing and measurement, its radius of gyration about a central axis perpendicular to its own axis being given by—

$$k^2 = \frac{r^2}{4} + \frac{l^2}{12}$$

where  $r$  is the radius and  $l$  is the length.

(4) *Close-coiled Helical Spring. Statical Method.*—By axially loading it, and measuring deflections directly, if large enough, or by a vernier as in Art. 178. From (2), Art. 117—

$$N = \frac{32WR^3 l}{\pi d^4 \cdot \delta}$$

where  $\delta$  is the average difference of deflection for a difference  $W$  of axial load.



(5) *Close-coiled Helical Spring. Kinetic Method.*—By vertical vibration of a heavy axial load  $W$  on the spring; if the mass of the spring is not negligible  $\frac{1}{3}$  of its weight must be added to  $W$  (see Art. 161). Then from Art. 159 (2)—

$$n = \frac{1}{2\pi} \sqrt{\frac{e \cdot g}{W}}$$

and from Art. 117—

$$e = \frac{3\pi d^4 N}{8R^2 l} \text{ per foot of deflection}$$

hence

$$N = \frac{128\pi W n^2 R^2 l}{32 \cdot 2 \times 12 \times d^4}$$

where  $n$  is the frequency of the vibrations per second, and all the linear dimensions are in inches.

*Poisson's Ratio*  $\left(\frac{1}{m}\right)$ .—(1) By measurement of  $E$  and  $N$  as above. Then from (1), Art. 13—

$$\frac{1}{m} = \frac{E}{2N} - 1$$

(2) By measurement of longitudinal strain by extensometers, Art. 174, and lateral strain by special instruments<sup>1</sup> of great magnification, generally optical. Then—

$$\frac{1}{m} = \frac{\text{lateral strain}}{\text{longitudinal strain}}$$

Other methods depend upon the changes of shape in the cross-section of bent beams, and therefore depend upon the accuracy of the theory of flexure.

*Bulk Modulus.*—(1) By measurement of  $E$  and  $N$  as above. From (4), Art. 13—

$$K = \frac{NE}{9N - 3E}$$

(2) By measurement of Poisson's ratio by method (2) above, and measurement of  $E$  or  $N$  as above. From (2), Art. 13—

$$K = \frac{1}{3} \cdot \frac{m}{m-2} \cdot E$$

From (1) and (2), Art. 13—

$$K = \frac{2(m+1)}{3(m-2)} \cdot N$$

It is also evident that the direct method (2) of measuring Poisson's ratio provides a method of measuring  $N$ , for from (1), Art. 13—

$$N = \frac{m}{2(m+1)} \cdot E$$

<sup>1</sup> See a paper by Morrow in the *Phil. Mag.*, October, 1903. Also a paper by Coker, *Proc. Roy. Soc. Edinburgh*, vol. xxv. p. 452.

## CHAPTER XVI.

### *SPECIAL TESTS.*

**182. Repeated and Reversed Stresses.**—*Wöhler's Machines and Tests.*—The celebrated experiments of Wöhler (see Art. 47) on the repetition of direct, bending, and torsional stress were made on machines which will be found illustrated and described<sup>1</sup> in Unwin's "Testing of Materials," chap. xiii.; the forces were applied and measured by the deflection of springs, the stiffness of which was measured. The Wöhler test most frequently repeated now is that of a rotating spindle fixed at one end and carrying a load at the other. It is important to notice that in all such bending tests, if the elastic limit is exceeded initially or during a test, the distribution of stress over a cross-section is unknown, and the maximum intensity of stress is not calculable. Simple direct stress is the only kind, the distribution of which can be accurately estimated if the limit of elasticity is exceeded.

*Dr. Smith's Machines.*—The introduction by Dr. J. H. Smith, acting on the suggestion of Prof. Osborne Reynolds, of a new method of applying repeated and reversed direct stress, marked a new development of repeated stress tests, which has already furnished considerable information on the subject (see Arts. 48 and 49), and promises more. In Dr. Smith's original machine<sup>2</sup> the simple direct stresses on the test piece were those resulting from the inertia forces of reciprocating masses driven from a rotating shaft by a crank and connecting rod, the test piece being placed between the connecting rod and the reciprocating weights. A more elaborate machine of the same type taking four specimens simultaneously has been used at the National Physical Laboratory by Dr. Stanton<sup>3</sup> (see Art. 49).

Probably the best machine employing inertia forces is Dr. Smith's Patent Reversal Testing Machine, made by Messrs. Combe, Barbour, Ltd. This machine is diagrammatically shown by elevation and half-sectional plan in Fig. 228, which represents one unit, a machine usually having two such parts. The alternating stress in the test piece T, which remains stationary, results from the horizontal component of the

<sup>1</sup> For a full description, see *Engineering*, vol. xi.

<sup>2</sup> For description and illustration, see *Phil. Trans. Roy. Soc.*, 1902.

<sup>3</sup> For description, see *Proc. Inst. C. E.*, vol. clxvi.

centrifugal force of the rotating masses *M*. One end of the test piece *T* is locked by a conical end, seated on split dies, to the piece *B*, part of which is of square section to prevent possible torsional vibration; the piece *B* forms a bearing at right angles to its own length for the rotating piece *C*, which carries the masses *M*. The other end of the test piece is locked to the piece *A*, which transmits the forces to the frame; to avoid initial stress *T* is locked first to *A* and then to *B*, and finally *A* is locked to the frame. To prevent damage to the machine after fracture of the test piece, buffers are inserted at *DD*. A spring *S*, with tightening nut *N*, provides a means of subjecting the test piece to any required initial stress, so that the inertia forces then cause

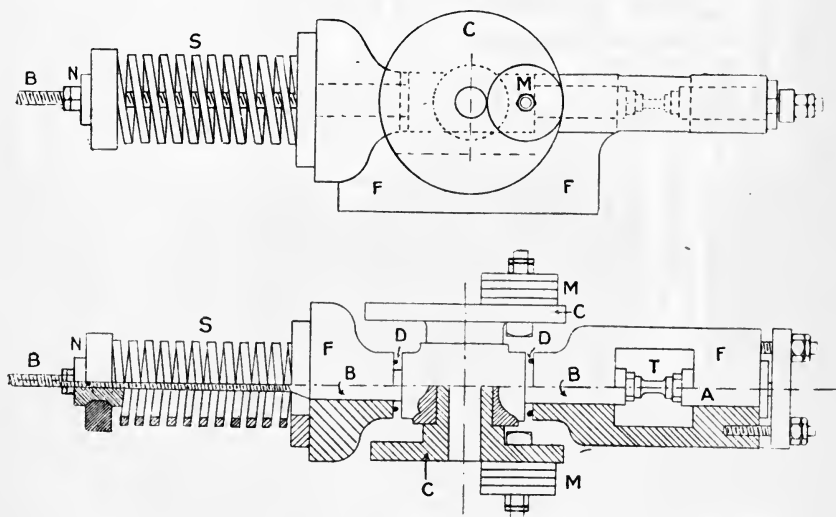

FIG. 228.—Dr. Smith's patent reversal testing machine.

stress between limits the mean value of which is not zero, the position but not the magnitude of the range of stress being altered. The motion of a driving shaft rotating in fixed bearings and co-axial with *C* is communicated to the rotating piece *C* by means of a pin fitting easily into a radial slot in a plate attached to the driving shaft. The driving shaft is placed between two such units as are shown in Fig. 228, and carries such balance weights as will balance the forces on the frame of the machine and prevent vibration of the foundation, and all the rotating journal bearings have forced lubrication. The standard test piece is turned down to  $\frac{1}{4}$  inch diameter for a length of  $\frac{1}{2}$  inch, and connected to the shoulders of larger diameter by well-rounded fillets. On such a specimen, by suitable changes of the revolving masses and the spring *S*, the machine is capable of giving stress intensities between practically any limits, and

of any speed of reversal except very low ones, within the limits of lubrication. A view of the machine as actually made is shown in Fig. 228A with letters of reference corresponding to those in Fig. 228.<sup>1</sup>

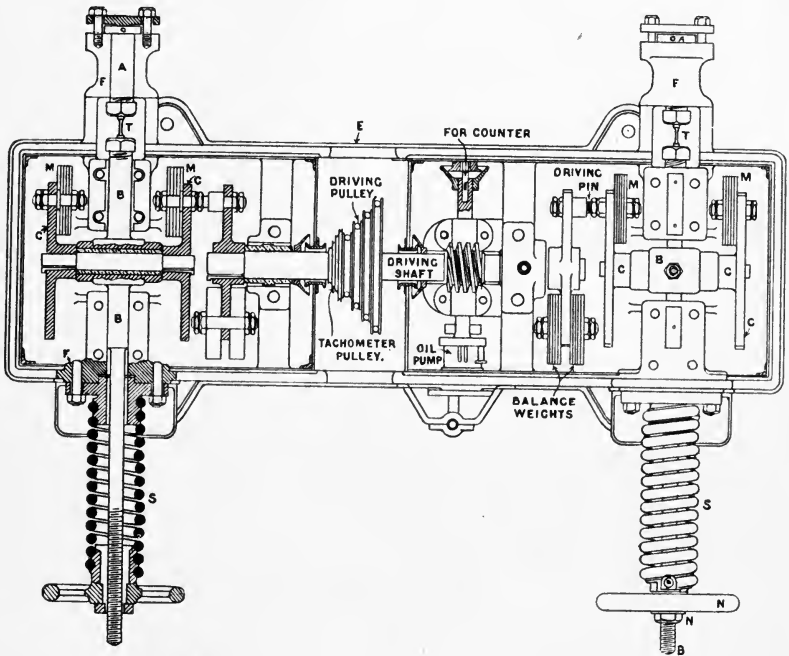

FIG. 228A.—Dr. Smith's patent reversal testing machine.

*Prof. Arnold's Testing Machine.*<sup>2</sup>—In this machine a bar  $\frac{3}{8}$  inch diameter is firmly fixed or *encastré* at one end, and is subjected to repeated bendings to and fro by a reciprocating plunger, through a slot in which the specimen passes. In his tests Prof. Arnold has standardised a rate of alternations of 650 per minute, and a distance of 3 inches between the striking line of the slotted plunger and the plane of maximum bending stress, where the specimen enters its clamp; the deflection of the specimen at the striking line of the plunger is  $\frac{3}{8}$  inch on each side of the undeflected position. With a fixed deflection, if the elastic limit were not exceeded, the intensity of bending stress would be proportional to Young's modulus for different materials, but the elastic limit is exceeded, and the intensity of stress is unknown; it is, however, under such conditions evidently different for different materials. The quantity measured is the number of alternations before fracture, and Prof. Arnold has found this a reliable guide

<sup>1</sup> See description in *Engineering*, July 23, 1909.

<sup>2</sup> *Brit. Assoc. Report*, 1904. Also *Proc. Inst. Mech. Eng.*, 1904, parts 3 and 4, p. 172, and *Proc. Inst. Naval Architects*, April, 1908; or *Engineering and Engineer*, April, 1908.

to the quality of different steels, and their capability to resist fracture by shock in use. The test is quite distinct from the reversal tests of Wöhler, Smith, or Stanton, in which the object is the determination of the range of stress which, under given conditions, a material will stand without fracture for an indefinitely large number of times, a measurement which, being a limiting value, naturally cannot be determined very quickly. In Prof. Arnold's tests the number of alternations never reaches 2000, and the time taken is therefore under 3 minutes per specimen. A correspondingly quick test could be made in any reversal testing machine by using a high range of stress. One of the points shown clearly by Prof. Arnold's test is the difference in quality in different parts of a large forging; the use of so small a test piece enables such differences to be investigated.

*Sankey's Hand-bending Machine.*—A common workshop test of the quality of material is to bend a piece to and fro through a definite angle until fracture occurs, the quality being judged from the number of times the

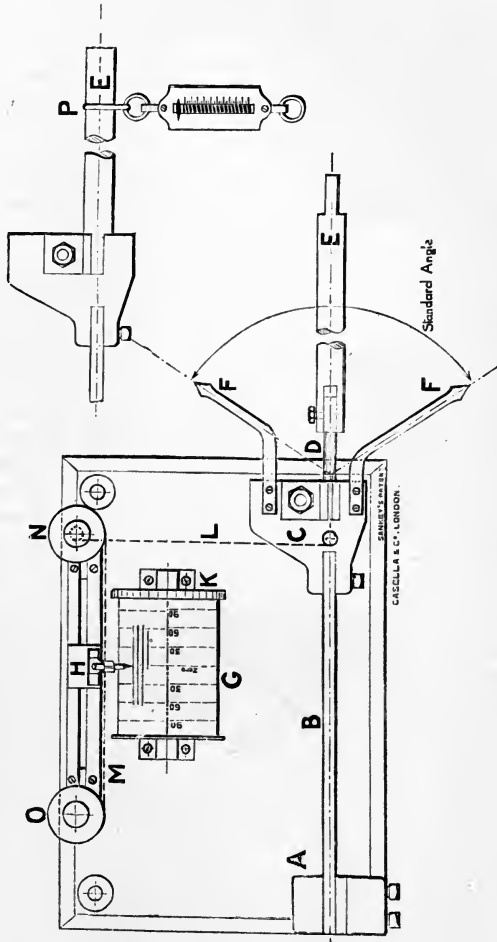

FIG. 229. — Sankey's hand bending machine.

piece bends before fracture. Captain Sankey has devised a small hand machine for carrying out this test and registering the number of bends and other information; Fig. 229 shows the arrangement of this machine, which is made by Messrs. C. F. Casella & Co. At one corner of the bed plate there is a grip A for securing one end of a flat steel spring B. The other end of the spring is fitted with a grip C, which also holds one end of the test piece D. The other end of the

test piece is fixed into a long handle E, by means of which it is bent backwards and forwards through the fixed angle shown by the indicator F. The bending effort or moment necessary on the handle to bend the test piece D through the fixed angle is measured by the deflection produced in the spring B ;

this deflection is recorded by the horizontal motion of the pencil H on the record paper placed on the drum G. The motion of the free end of the spring is transmitted by a steel strip L to a multiplying pulley N, and then by a steel strip M, which is kept taut by the spring box O, to the pencil H. The pencil moves in one direction from the zero line in the centre of the paper when the bending is from right to left, and in the opposite direction when it is from left to right, and in either case the distance moved from the zero line is proportional to the resistance offered by the test piece D to bending. The motion of the pencil carrier advances the drum through one tooth of a ratchet wheel K at the end of each bend, and so an autographic diagram of the character partially shown on the drum G in Fig. 229 is produced. The general appearance of the machine is shown in Fig. 230. The record is made on a paper graduated in pound-feet (see G, Fig. 229), the free length of the spring B being suitably adjusted at the grip A. Cali-

bration is effected by reversing the lever E, the outer end of which has a reduced portion to fit into C, and finding by a spring balance, the ring of which is placed in a groove P, the pull at a distance of 3 feet from the point of bending of the test piece to bring the pencil to any particular graduation line on the record paper. The standard or fixed

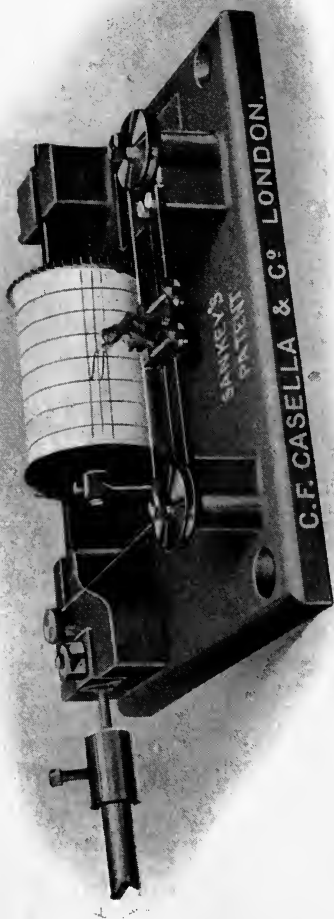

FIG. 230.—Sankey's hand bending machine.

angle of the indicator  $F$  is two radians, hence the energy in foot-pounds absorbed by a complete bend from left to right, say, is equal to the bending moment in pound-feet multiplied by 2, the material being nearly plastic, and since the drum is advanced an equal distance after each bend, the area enclosed by a line joining the outer tips of all the lines of the diagram is proportional to the total energy absorbed in fracturing the piece on a scale dependent on the recording gear. The principal indications of the machine are firstly, the number of bends which is a measure of the ductility; secondly, the bending moment necessary for the first bend which may be taken as a measure of the yield stress; and thirdly, the total energy absorbed during the bends until fracture takes place; this may be taken as some measure of the quality, its precise significance and relation to quantities obtainable from a statical tension test still requiring examination.<sup>1</sup>

**183. Single Bend Tests.**—A common test for structural steel is to bend it over through  $180^\circ$ ; for a flat piece of metal to withstand such treatment without fracture or cracking is evidence of its ductility, for the outer surface undergoes considerable elongation. The bend test is often specified to occur at different temperatures; at ordinary atmospheric temperatures it is called the cold bending test. It is sometimes specified for iron or steel at a red or at a blue heat, when a freshly filed surface takes a blue colour.

Under the name of the *temper bend test* it is also used for structural steel on pieces heated to a blood-red heat and then quenched in water below  $80^\circ$  F. If the flat test pieces for bend tests are sheared from pieces of variously shaped section, it is usual to machine or grind the sheared edges to cut away the material which may have been hardened by shearing. The practice in bending tests is not uniform with regard to the acuteness of the bending: sometimes the piece is completely closed down so that the two parallel faces touch each other; in other cases the two parallel faces are distant from one another by twice some specified internal radius of curvature of the bend. The requirement of the British Standards Committee for structural steel is that the test pieces must withstand without fracture being doubled over until the internal radius is not greater than  $1\frac{1}{2}$  times the thickness of the test piece and the sides are parallel; the test piece is to be not less than  $1\frac{1}{2}$  inch wide.

The bend test may be made by pressure or by blows, and by the latter method only common workshop appliances are required, hence the test is a very common as well as a very good one; wrought iron or steel which will fold completely through  $180^\circ$  with an internal radius of curvature zero is unquestionably of high quality. For material of poorer quality, the angle through which it bends before fracture has sometimes been used to indicate its quality.

**184. Hardness Tests.**—Hardness is perhaps best defined as the resistance to penetration by other bodies.

The various tests which have been devised to determine hardness are of two classes, which may be called Indentation tests and Scoring

<sup>1</sup> See papers in *Engineering*, December, 1907; also paper on Comparison of Tests in *Proc. Inst. M.E.*, May, 1910.

or Scratching tests. Indentation tests have been arranged with punches

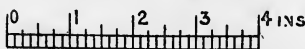
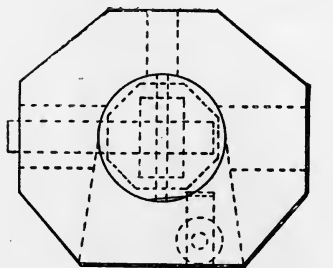
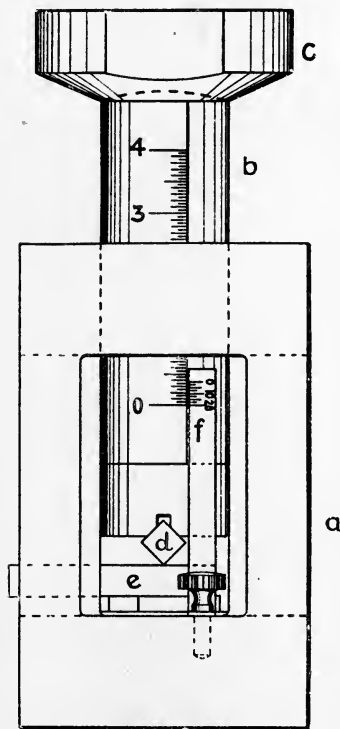

SCALE

FIG. 231.

(From Unwin's "Testing of Materials.")

or indenting tools of various shapes, and various methods of measurement have been adopted. The depth, superficial area, or volume of indentation by a given static pressure, or by the impact of a given weight falling through a given height, may be measured, or the pressure or blow necessary to give some specific indentation may be measured. One of the objections to all indentation methods of hardness testing is the difficulty of producing the same degree of hardness in all punches or indenting tools. A method of hardness testing adopted in the United States Ordnance Department was to give a blow, by a given weight falling through a given distance, to a punch of pyramid shape, the section being a rhombus having one very long and one very short diagonal. The comparative degree of hardness was then taken as inversely proportional to the volume of indentation. This volume is proportional to the cube of the linear dimensions of the pyramid-shaped cavity which can be calculated after measuring the long diagonal of the rhombus on the plane surface indented.

*Unwin's Hardness Test.*<sup>1</sup>—In this test a plunger *b* (Fig. 231), which fits loosely in a guide block *a*, transmits the pressure to an indenting tool *d*, consisting of a piece of hardened and ground  $\frac{3}{8}$ -inch square steel  $2\frac{1}{2}$  inches long, which indents the small flat test piece *e*. The downward movement of the plunger *b* is measured by a sliding scale attached to *b*, read by a vernier *f*, fixed to the frame. The apparatus is used between the compression plates of an ordinary testing machine, the head *c* making spherical joint with the plunger *b* and, allowance being made for the compression of the apparatus as determined by a

<sup>1</sup> *Proc. Inst. Civil Eng.*, vol. cxxix.



separate test, the scale readings give the depth of indentation. For various pressures  $p$ , taken by Unwin per inch of width, the indentation followed a law—

$$\frac{p^n}{i} = C$$

where  $i$  is the depth of indentation and  $C$  is a number representing the hardness, the index  $n$ , found for any particular material by plotting logarithms of  $p$  and  $i$ , being about 1.2 for mild steel and not greatly different for other metals.

*Brinell Hardness Test.*—All pointed indenting tools are likely to lose their sharpness, and subsequent tests may be much affected by the loss of the keen edge. Probably a spherical ball offers the best form for the purpose of making the indentation. This is the shape used in the method of hardness testing elaborated by Mr. Brinell, which is perhaps in wider use than any other. The test consists of forcing a hardened steel ball of definite size into a flat surface of the material to be tested, under a definite pressure and measuring the diameter of the indentation. Brinell takes the hardness as proportional to the area of the cavity made by a fixed pressure and size of ball. If  $D$  is the diameter of the depression and  $r$  the radius of the ball and  $P$  the total pressure, the area of the curved spherical surface of the cavity is—

$$2\pi r \left( r - \sqrt{r^2 - \frac{D^2}{4}} \right)$$

$$\text{and Brinell hardness number} = \frac{\text{total pressure}}{\text{curved area of depression}} \\ = \frac{P}{2\pi r \left( r - \sqrt{r^2 - \frac{D^2}{4}} \right)}$$

a number which depends only on  $D$  if  $P$  and  $r$  are fixed. The usual size of ball is 10 millimetres diameter ( $r = 5$  mm.), and the pressure  $P = 3000$  kilogrammes. The diameter  $D$  of the indentation is usually read to  $\frac{1}{20}$  mm. by means of a microscope, and the hardness number obtained from a table. Different values of  $P$  actually give different hardness numbers: probably a hardness number based on  $P^n$  instead of  $P$ , where  $n$  is a constant for a given material, would give a constant hardness number for different pressures, but the "standard" Brinell hardness number is that derived as above from the 10 mm. ball and the pressure ( $P$ ) of 3000 kilogrammes.

Benedicks of Upsala has found that balls of different sizes give the same hardness number if the Brinell hardness number is multiplied by the fifth root of the radius of the ball, *i.e.*—

$$\text{Benedicks' hardness number} = \frac{\text{total pressure}}{\text{curved area of depression}} \times \sqrt[5]{r}$$

To convert the standard Brinell hardness numbers ( $r = 5$ ) to Benedicks' hardness numbers it is only necessary to multiply by  $\sqrt[5]{5}$  or 1.38.

Benedicks, by plotting as ordinates the hardness numbers obtained with different working pressures on the ball against the pressures as abscissæ, has found for various working pressures a constant ratio between the hardness numbers of two substances when pairs of hardness

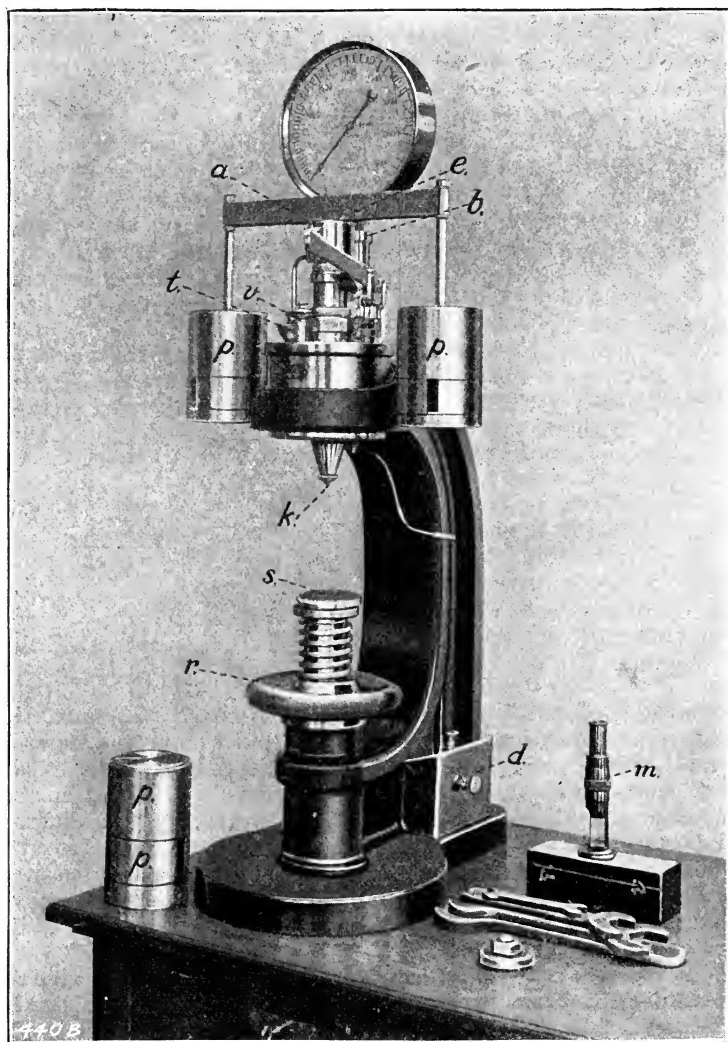

FIG. 232.

numbers of each metal are measured for the same pressure. He has also investigated the relation between the Brinell hardness numbers as obtained by different working pressures and the pressures, but this is of

little importance since there is no disadvantage in working at the standard pressure of 3000 kilogrammes.

Dillner of Stockholm has investigated the relation between the hardness numbers and the tenacity of Swedish steels over a wide range of carbon contents; he finds a remarkable correspondence over wide ranges of hardness; thus with a mean error of 3·3 per cent. the tenacity in tons per square inch of the steels having a hardness number below 175 (including all the structural steels) is found by multiplying the hardness number by 0·230 when the indentation is made transversely to the direction of rolling, or 0·225 when it is made in the direction of rolling. Charpy has found a similar result for French steels. The hardness test thus offers a very handy way of getting an approximate estimate of the tenacity of steel from a very small sample without the cost of preparing an ordinary tensile test piece; in some cases the actual materials instead of a severed sample can be tested. Such a test along with impact tests (Art. 185) as a criterion of ductility have found a certain amount of favour as a practical workshop system of testing materials.

*Hardness Testing Machines.*—Figs. 232 and 233 show the Brinell hardness testing machine made by the Aktiebolaget Alpha and Messrs. J. W. Jackman, Ltd. The ball  $k$  is attached to the lower side of a piston, above which the necessary oil pressure is applied. The filed or ground sample to be tested is placed on the stand  $s$ , and raised into contact with the ball by means of the hand-wheel  $r$  (Fig. 232). The valve  $v$  (Fig. 233), connecting the upper side of the piston to the oil reservoir, is then closed, and the pressure is produced by a small hand-pump. As soon as the requisite pressure of 3000 kgms. (total) is reached, it is indicated, not only by the pressure gauge, but by the rise of the small upper piston carrying the crossbar  $e$  and the necessary (adjustable) dead loads  $p$ , and further rise of pressure is therefore prevented and the correct pressure is assured. The piston is accurately fitted without any packing, and friction is thereby eliminated; any leakage of oil past the piston goes by a pipe into the receptacle  $d$ , whence it is poured into the reservoir through the funnel  $f$ . After the test, the valve  $v$  having been opened, the piston is drawn up to its original position by means of the helical spring shown above it. The diameter of the impression made by the ball is measured by means of the microscope  $m$ .

Guillery<sup>1</sup> has designed a machine for hardness testing on the Brinell system; the pressure is given by a hand-lever, and is regulated by a definite deflection of a pile of Bellville springs (hollow circular dished plates).

Brinell has designed a hardness testing apparatus in which the impression of the ball is given by the impact of a definite mass with a definite fall. Guillery has designed an impact ball hardness tester in which a blow is transmitted to the ball through Bellville springs which can only deflect a specified amount, and the excess kinetic energy of the blow is then taken up elsewhere.

Brinell's experiments on ball-hardness tests by a constant impact showed that an impact which produced the same impression as 3000 kgms. static pressure on a very soft steel produced an increasingly

<sup>1</sup> See *Engineering*, January 12, 1906, or *Engineer*, October 28, 1904.

greater impression than that due to the same static pressure on steels of increasing carbon contents, *i.e.* for harder steels the ratio of the hardness numbers to those obtained by the static test diminished if the ratio was made unity for a soft steel. Roos of Stockholm has shown by experiment that the static hardness numbers for low carbon steels may be found approximately by taking them as proportional to the

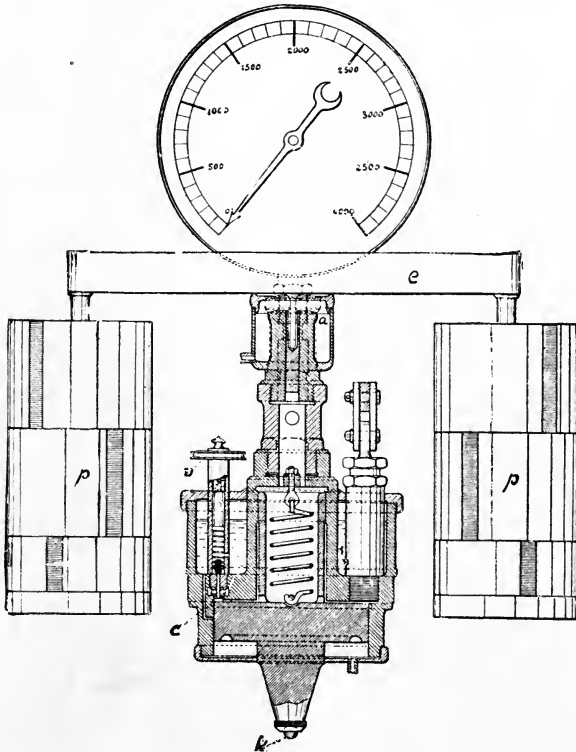

FIG. 233.

square of the number found by the ball-hardness test under constant impact. An experimental constant used over a moderate range of steels of different hardness gives a fairly consistent result from the formula—

$$\text{static hardness number} = \frac{(\text{impact hardness number})^2}{\text{constant}}$$

*Scoring or Scratch Test for Hardness.*—Professor Martens of Berlin has standardized a scratch test in which a diamond point loaded by a movable poise on a lever scratches the test piece. He used two methods of comparison of materials—(1) the loads which produce a scratch 0.01 mm. wide, and (2) the width of scratch under a given load, the width of scratch in either case being determined by means of a microscope.

**185. Impact Tests.**—The failure in materials used in high-speed machinery under repeated forces of an impulsive character, even when such material has shown satisfactory strength and elongation in a static tensile test, has led to many attempts to devise a shock or impact test which should discover the imperfection in a material likely to fracture by "shock."

Impact testing machines generally attempt to measure the energy absorbed by a test piece in fracture by a single blow or the number of blows of given energy necessary to produce fracture. Machines in which the blow given by a falling weight fractures a test piece by simple tension<sup>1</sup> or compression have been constructed. One of the greatest objections to such a machine is the impossibility of calculating the proportion of the energy absorbed in straining the test piece when part of the energy is necessarily spent in deformation of the falling weight, the frame or anvil of the machine, and the foundations. This makes standardization of such a machine and test almost impossible, although instructive comparative results may be obtainable from one machine in which the conditions of the test can be exactly repeated. The most usual kind of impact test is the transverse or bending test on small pieces, either plane or with a standard form of notch or groove cut in them.

*Repeated Transverse Blows.*—Sometimes a test is made to determine how many transverse blows a rail will stand without fracture, or sometimes the magnitude of the greatest blows is specified. This evidently depends considerably upon the rigidity of the supports of the rail; it has been pointed out (Art. 45) that with variable blows the magnitude of the blow necessary to cause fracture depends in no simple manner upon the number and magnitude of the previous blows. A machine for testing materials by repeated transverse blows on a small nicked or notched test piece has been described and discussed by Messrs. Seaton and Jude.<sup>2</sup> The quantity measured is the number of blows of a definite weight falling through a fixed height on the test piece before fracture takes place. For general use, evidently the size of test piece, height of fall, and weight of tup or hammer would have to be standardised. Like all impact machines, for standardisation it would require a definite weight and kind of frame or anvil and foundations.

*Single Transverse Blow.*—A single-blow impact machine of the pendulum type, made by Messrs. W. and T. Avery, is shown in Fig. 234. The nicked test piece, which is 2 inches long,  $\frac{3}{16}$  inch thick, and  $\frac{3}{8}$  inch broad, is held in a vice with the axis of the 60° V notch set by gauge in the plane of the vice jaws. The pendulum, having a striking edge at its centre of percussion, is released by a trigger from a definite height, strikes and fractures the test piece, and passes onward; the height to which it reaches at the end of its swing is recorded by a pointer moved over a scale by the upper end of the pendulum rod. The difference in height of the centre of gravity of the pendulum at the starting-point and the end of its swing, multiplied by the weight of the pendulum, gives the

<sup>1</sup> At the National Physical Laboratory: see *Proc. Inst. Mech. Eng.*, 1908, p. 889, and May, 1910; also at Purdue University: see *Engineering*, July 4, 1902, p. 28.

<sup>2</sup> *Proc. Inst. Mech. Eng.*, November, 1904; see also *Proc. Inst. Mech. Eng.*, 1908, p. 889.

energy absorbed by the blow ; the scale is graduated to record this quantity directly in foot-pounds, and would give the energy absorbed in fracturing the test piece if the base and other parts were absolutely rigid. Pendulum single-blow impact testing machines have also been used by Charpy<sup>1</sup>



FIG. 234.

and by Russell.<sup>2</sup> Another form of impact machine<sup>3</sup> has a flywheel, a striker on the circumference of which fractures the test piece. The speed of the flywheel before and after impact is observed by a fluid tachometer, and from these readings the energy absorbed is determined.

<sup>1</sup> See *Engineer*, March 10, 1905 ; also *Engineering*, November 9, 1906, and June 19, 1908.

<sup>2</sup> See *Trans. Am. Soc. Civil Eng.*, 1898.

<sup>3</sup> See *Engineering*, January 12, 1906, or *Engineer*, October 28, 1904.

## CHAPTER XVII.

### *SPECIAL MATERIALS.*

**186. Cement.**<sup>1</sup>—Cements are produced by roasting limestone with various amounts of clay, either as found in nature or artificially added, the product being subsequently finely ground. The most important cement used by the engineer is Portland cement, which is made from a mixture of about 3 parts of limestone or chalk to 1 part clay, forming a calcium silicate and a calcium aluminate; natural and other cements differ mainly in having a smaller proportion of clay, limes having little or none except hydraulic limes, which have a small proportion and are capable of setting under water. Portland cement, the manufacture of which has undergone rapid expansion and alteration, is a product which can be made with remarkable regularity as shown by a number of distinct tests. When mixed with water it combines chemically with a certain quantity and sets in a solid mass impervious to water. This hydraulic property is due to the presence of a silicate of alumina; the proportion of lime in Portland cement is about  $2\frac{1}{2}$  to 3 times the combined weight of the silica and alumina. Gypsum present with the limestone calcium forms sulphate or plaster of Paris; up to 2 per cent. the effect of this substance in cement is to increase the time taken to set hard, which is often an advantage; beyond this amount it is injurious.

**187. Tensile Cement Tests.**—Portland cement is not usually in practice subjected to tension, but only to compression; it is not usually employed alone or "neat," but in a mixture with inert material such as sand, broken stone or brick; nevertheless, the tensile test of neat cement is the usual strength test employed, because under carefully specified conditions it is found to be a good index of quality. For tensile tests the neat cement is mixed with water and allowed to set in a mould to form briquettes; the form of the briquette and holding clips of the testing machine have a considerable influence on the distribution of stress on the breaking section of the briquette, and therefore have to be standardised. Fig. 235 shows the standard form of briquette adopted by the Engineering Standards Committee, the briquette being 1 inch thick and 1 inch square at the minimum section. Fig. 236 shows the standard clips or jaws by which the briquette is held during the tension test. A form of briquette used on the Continent is shown at *i* in

<sup>1</sup> See three papers in *Proc. Inst. Civ. Eng.*, vol. cvii.

Fig. 239, and mould for forming the briquettes is shown in Fig. 238. For neat-cement tests the quantity of water used in mixing or gauging

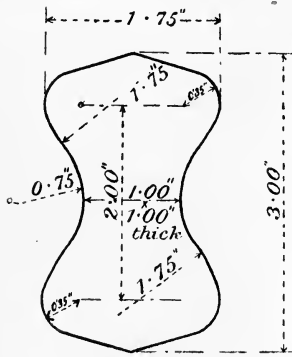

FIG. 235.

The tensile breaking load of a briquette is considerably affected by the rate at which the load is applied,<sup>2</sup> increasing with increase of speed

has a considerable influence on the strength of the briquette and should be such as to just form a smooth paste; for any particular Portland cement there is a proportion of water, to be found by experiment (usually from 18 to 25 per cent. by weight of the cement), which gives the highest possible tensile strength.

Cement increases considerably in resistance both to tension and crushing, with age from the time of setting,<sup>1</sup> consequently the age and treatment of briquettes after mixing must be specified; the increase of resistance to crushing is fortunately greater than the increase of tensile strength.

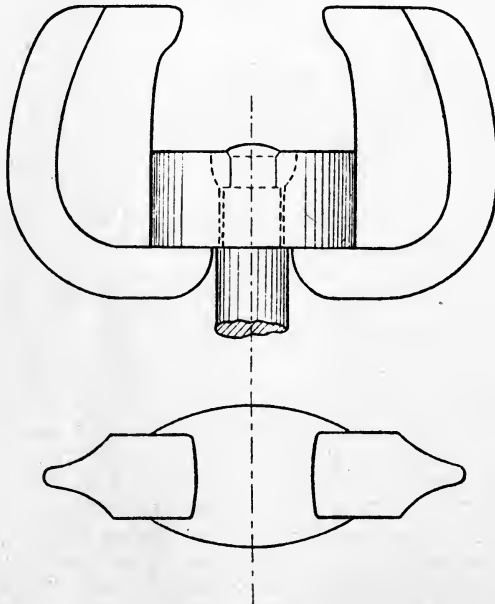

FIG. 236.

<sup>1</sup> See papers by Mr. J. Grant, *Proc. Inst. Civ. Eng.*, vols. xxv. and xxxii.

<sup>2</sup> See a paper by Mr. Faija, *Proc. Inst. C.E.*, vol. lxxv.



of loading; the rate has therefore to be standardised, and on the briquette shown in Fig. 235 the Standards Committee specify a rate of 100 pounds in 12 seconds, *i.e.* 500 pounds per minute.

Specifications of ultimate tensile strength of course vary, but the "Standard" specification for the square inch section gives the following figures for a briquette, made without mechanical ramming into the mould, kept for 24 hours in a damp cloth in the atmosphere, and then placed in fresh water until tested:—

7 days from gauging,	400 pounds per square inch of section						
28	"	"	500	"	"	"	"

the increase from 7 to 28 days to be not less than 25, 20, 15, or 10 per cent. according as the 7 days' test gives a result of 400 to 450, 450 to 500, 500 to 550, or over 550 pounds per square inch respectively. The results are to be measured by the average of 6 briquettes for each period.

*Sand Mixture Tests.*—As according more nearly with the use of cement in practice, tests are often made of briquettes moulded from a mixture of 3 parts by weight of sand to 1 part of cement. This is a test of the adhesion of the cement and sand, and is of course affected by the particular size and shape of the grains of sand used. Different countries adopt their own standard sands. The British standard sand is obtained from Leighton Buzzard, and such part is used as passes through a sieve having  $20 \times 20$  wires 0.0164 inch diameter per square inch, and remains on a  $30 \times 30$  sieve made of wire 0.0108 inch diameter. The sand and cement, being mixed with so much water as to thoroughly wet the mixture and leave no superfluous water when the briquette is formed, should have a tensile strength of—

120 pounds per square inch	7 days after gauging				
225	"	"	28	"	"

with an increase of at least 20 per cent. in the interval.

**188. Compression Tests.**—Compression tests of cement are not very frequently made, the tension test being satisfactory and much simpler. When compression tests are made an ordinary testing machine may be used on about 3 or 4-inch cubes; the difficulty and influence of a satisfactory bedding for compression tests has been mentioned in Art. 37. The ultimate strength of neat cement under pressure is from about 8 to 11 times its tensile strength, the ratio increasing with age. The stress-strain curve, unlike that for metals, generally starts from zero concave to the axis of stress, and becomes at great loads somewhat convex to it. Fracture takes place in the manner characteristic of brittle materials by shearing at angles of about  $45^\circ$  to the direction of compression (see Fig. 237).

**189. Cement Testing Machines.**—Tension tests of cement briquettes are generally made on special testing machines of various types, single and compound levers being used. The application of the load at a steady and definite rate is in some cases accomplished by running

water or fine shot through a controllable opening into a vessel hanging from the end of the lever; in other cases a travelling poise is caused to move along a graduated lever at a steady speed.



FIG. 237.—Portland cement.

(From Goodman's "Mechanics applied to Engineering.")

A single-lever testing machine, made by Mr. Adie, with a regulated travelling poise D is shown in Fig. 238. The briquette is placed in the clips BC, and the hand-wheel R serves to tighten the screw attached to the lower clip C, so as to raise the lever F into a position of balance between the stops on the standard E. The poise D may be moved along the lever F by means of the handle at the end of the beam. For loading at a uniform rate the traverse of the poise is accomplished by the pull of a suspended weight W, regulated by a dashpot cylinder below the pulley *g*; the rate of traverse is regulated by adjusting a cock in the piston of the dashpot.

Fig. 239 shows the form of another of Messrs. Adie's cement-testing machines, designed by Dr. Michealis; this machine, which is of the compound-lever type and is loaded by shot, may be taken as typical of German practice. The briquette *i* is held between clips *d* and *e*, the lower one of which is attached to a straining screw turned by the hand-wheel *f*. The pull on the briquette is balanced

through two levers against the weight of shot in the vessel *c* at the end of the lever *a*, which also carries an adjustable balance weight *b*; the

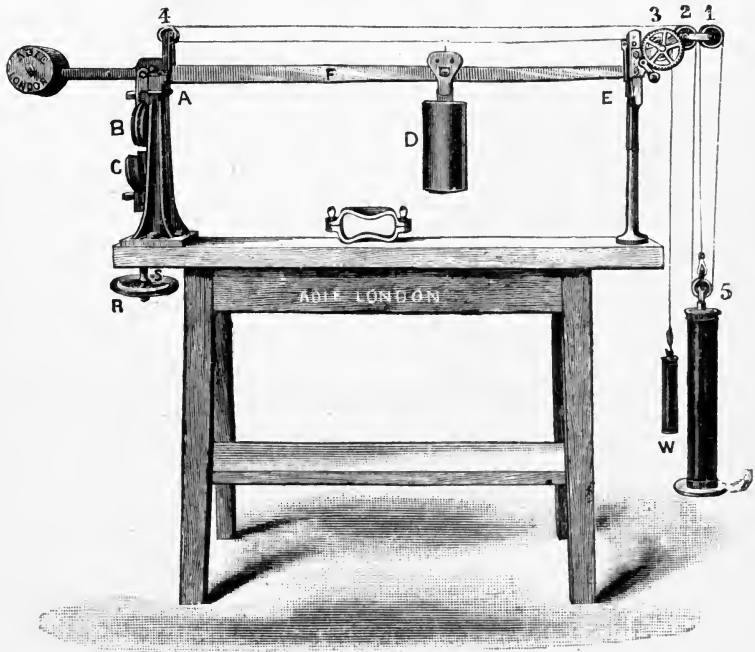

FIG. 238.

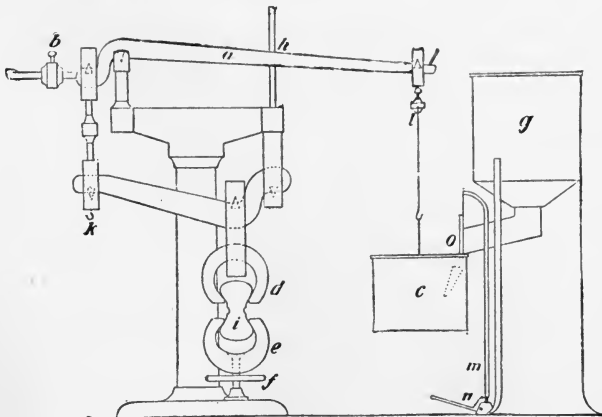

FIG. 239.

combined leverage of the two levers is 50 to 1. The shot runs into the vessel *c* from a reservoir *g* through a channel, which is regulated at

$\sigma$  for any desired rate of loading by a lever  $n$ . The breaking of the briquette and consequent fall of the lever automatically shuts off the supply of shot, and 50 times the weight of shot in  $c$  gives the breaking load, this quantity being recorded by a spring balance at  $l$ .

**190. Other Cement Tests.**—In addition to the tensile test of cement the allowable amounts of moisture and of calcium sulphate is often specified, also the maximum proportion which the weight of lime shall bear to the combined weight of the silica and alumina; the "Standard" specification gives this ratio as 2.75. Any excess of this quantity of lime causes crumbling of the cement after setting.

*Fineness Tests.*—Coarse grains in cement have a weakening effect similar to that of sand or other inert matter, and to test the fineness of grinding the cement is sieved, and the proportional residue by weight on sieves of given dimensions is found. The Standards Committee specification requires that the residue on a sieve with  $76 \times 76$  wires, 0.0044 inch diameter per square inch, shall not exceed 3 per cent., and on a sieve  $180 \times 180$  wires, 0.002 inch diameter, it shall not exceed  $22\frac{1}{2}$  per cent.

*Specific Gravity.*—Imperfectly burned cement is lighter than cement of good quality; also cement which is left exposed to the atmosphere, by absorption of moisture and carbonic acid, deteriorates and loses its capability of combining with water, a change which is accompanied by a loss of specific gravity. On the other hand, a certain amount of aeration may be necessary to slake any free lime which would cause cracking or crumbling in the cement. It is sometimes specified that Portland cement shall weigh 112 to 115 pounds per bushel, but perhaps a better practice is to specify a specific gravity of 3.10 after delivery. Considerable doubt has been cast on the value of the specific gravity test as an indication of proper calcination.<sup>1</sup> The specific gravity is measured by the displacement of the level of turpentine in a long, narrow, graduated neck of a glass vessel; when a weighed quantity of cement is dropped into the vessel the weight of the cement in grammes, divided by the displaced volume of turpentine in cubic centimetres, gives the specific gravity. Another plan is to fill a narrow-necked bottle with water to a given level and weigh it; pour off some water and add a weighed quantity of cement, and fill up with water to the original level and weigh again. The weight of water equal in volume to the cement used, is then equal to the weight of cement used, minus the difference between the second and first weights of the bottle and contents, and the specific gravity is equal to the weight of cement, divided by the weight of an equal volume of water as above calculated, or—

$$\text{sp. gravity} = \frac{\text{weight of cement added}}{\text{1st weight of bottle} + \text{wt. of cement} - \text{2nd wt. of bottle}}$$

*Soundness Test.*—The Le Chatelier test of soundness is made in the apparatus shown in Fig. 240, which consists of a small split cylinder of brass C, 0.5 millimetre in thickness, forming a mould 30 millimetres

<sup>1</sup> See a paper by D. B. Butler, *Proc. I.C.E.*, vol. clxvi. part iv.

internal diameter, and 30 millimetres thick. Pointers PP are attached on either side of the split and have a length of 165 mm. from the tips to the centre of the cylinder. The mould is placed on a piece of glass and filled with the usual mixture of cement and water, the split edges being meanwhile gently held together. After filling, the mould is covered by a glass plate and a small weight, and placed in water at  $58^{\circ}$  to  $60^{\circ}$  F., and left 24 hours. The cement will then be set, and the distance between the pointers PP is measured on a millimetre scale, and the mould is placed in cold water, which is then heated to boiling point and kept boiling for 6 hours. After cooling, the distance between the pointers PP is again measured. Excessive cracking of the cement due to an excess of free lime or otherwise, is indicated by excessive movement

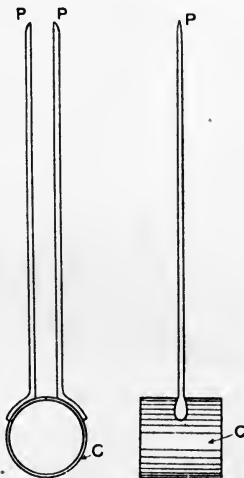

FIG. 240.

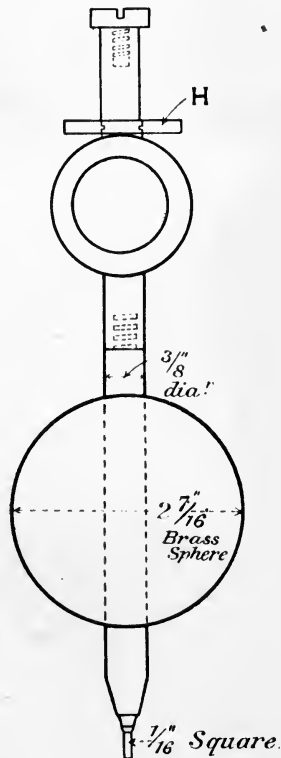

FIG. 241.

apart of the pointers during the test. The "Standard" specification allows an expansion not exceeding 6 millimetres in cement which before mixing has been exposed to the air for seven days.

*Time of Setting.*—The time of setting of a briquette or pat mixed in the usual way is tested by the indentation of a weighted "needle," of the form shown in Fig. 241, which has a flat end  $\frac{1}{16}$  inch square, and weighs  $2\frac{1}{2}$  lbs. The cement is considered to be "set" when the needle fails to make an impression when its point is gently applied to the surface, the needle being lifted into position by means of the loose

hollow ring or washer H. The time of setting to be specified depends upon the requirement of the work for which the cement is intended, and varies from between 10 and 30 minutes for quick-setting cements to between 2 and 5 hours for slow-setting cements.

191. **Concrete, Stone, and Brick.**—*Concrete* is sometimes tested by crushing of cubes of about 9-inch sides; the strength increases with age after the time of setting, and usual ages for comparative tests are 3 and 9 months. Fracture takes place as in other brittle solids by shearing at angles of about  $45^\circ$  to the direction of compression (see Art. 37), the broken cube having somewhat the appearance of two pyramids with a common apex (see Fig. 242). The strength of course



FIG. 242.

(From Unwin's "Testing of Materials of Construction.")

varies with the proportion and character of the inert materials used with the cement; for more detailed information on various mixtures, treatises on concrete should be consulted.

*Stone.*<sup>1</sup>—The strength of stone subjected to crushing stress, as it usually is in buildings, varies greatly with the character of the stone, granite having often a strength of 1500 tons per square foot, while sandstone and the weaker varieties of limestone may often have only about a quarter or a fifth of this crushing strength. A building stone is generally chosen rather from considerations of durability and appearance than for its ultimate crushing strength, which, except in very tall

<sup>1</sup> Strength, density, and absorption tests of British stones from various quarries may be found in a paper by Prof. T. Hudson Beare, *Proc. Inst. C.E.*, vol. cvii.

structures, is often much more than sufficient for all requirements. The porosity of stone is tested by weighing the stone when dried and then after saturation by immersion in water.

*Brick.*—The strength of bricks varies greatly with the composition of the clay from which they are made, the method of manufacture, and other causes. The average strength of a common brick may be taken as about 150 tons per square foot, and of blue Staffordshire bricks about 400 tons per square foot.

*Crushing Tests of Concrete, Stone, and Brick.*—The great influence of the kind of bedding of brittle material during crushing tests has been mentioned in Art. 37, and is further illustrated in Fig. 243, which shows the fracture of three 4-inch cubes of Yorkshire grit. The left-hand one had 3 plates of lead each  $\frac{1}{12}$  inch thick on each pressure face, and broke in the manner shown at 36 tons; the middle one had single plates of lead bedding, and stood 56 tons; while the right-hand one was bedded on millboards, and stood 80 tons. Setting in plaster of Paris often gives a result higher than with the cardboard bedding, and it, as well as millboard, is often used in crushing tests. It is to be remembered that in actual structures the crushing strength of such materials is less than that of a single piece as tested, and depends partly on the nature of the mortar in which it is set; a soft mortar which flows under pressure will tend to cause a tensile stress perpendicular to the direction of compression.

In crushing tests of these

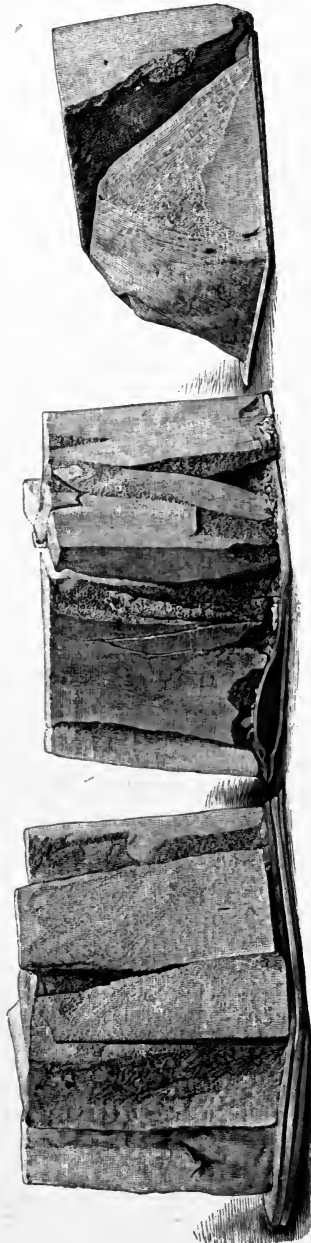

FIG. 243.

(From "Unwin's Testing of Materials of Construction.")

brittle materials the chief function of the bedding should be to evenly distribute the pressure, and prevent failure from high local pressure which would result from unevenness of the external faces to which the pressure is applied; to obtain the highest strength the outer faces should be carefully smoothed and made parallel, and a spherical seating of the compression plate of the testing machine should be used.

**192. Timber.**—The cross-section of a tree trunk from the outer bark to the central pith consists of two parts, an inner and darker core of *heartwood* and an outer portion of *sapwood*. Both heartwood and sapwood may be seen to consist of a number of tubes showing in section rings, which are called annual rings, each representing one year's growth of the tree. Closer inspection of an annual ring will reveal two kinds of growth in each ring, the inner and less dense portion being the spring growth, and the outer portion the summer growth. Slow growth of the tree is indicated by closeness of the rings, and is associated with greater strength than is quick growth. In mature trees the heartwood is stronger and more valuable than the sapwood, unless the tree is so old that the process of deterioration of the heartwood has set in.

**193. Strength of Timber.**—The strength of a piece of timber is greatly different in different directions, being much greater for tension and compression along the grain than across it, in which direction the fibres have not to be broken, but merely torn from one another, the resistance being more a question of adhesion than strength in the usual sense. Further, the strength of a stick of wood depends upon the part of the tree from which the piece is cut, whether from the heartwood or sapwood, and whether from the upper or lower part of the tree. The strength of timber is also greatly affected by the amount and kind of seasoning it has undergone, the place and soil in which it was grown, the age of the tree, and the season at which it was cut down. Generally speaking, the heavier woods are stronger than the lighter ones, the comparison being made between different woods in the same stage of dryness.

**194. Tests of Timber.**—*Number of Test Pieces.*—In so variable a material as timber it is necessary, in order to draw reliable conclusions, to test a large number of similar pieces, and to take the average results of these tests.

*Size of Test Pieces.*—Small pieces are not satisfactory for a material like timber, which contains a certain proportion of knots and other local defects, for such a defect, happening to lie in a small test piece, will cause an extremely low strength to be recorded; and if, on the other hand, the test piece is picked so as to be free from all defects, the result will be to give too high a value for the true average sample; hence in important timber tests large sections are used. Investigation shows, however, that a large section has the same strength per square inch as a small one when both are of the same proportion and similarly free from defects.

*Effects of Moisture.*—A piece of timber attains its maximum strength after having dried out of it all but about 4 or 5 per cent. of its own weight of water. Very wet (fresh-cut) timber has about half this



maximum strength, and in the process of drying its strength begins to rise when the moisture present gets below 60 per cent. of the weight of dry timber, and rises steadily with decrease of moisture to the maximum strength. For comparison of different woods it is necessary to adopt a definite standard percentage of moisture; from 12 to 15 per cent. is usually chosen, this being the amount retained after good air drying; with a moisture percentage below 10, water is rapidly absorbed from the atmosphere. The weakening effect of moisture which has been reabsorbed by timber previously dried, is almost identical with that of the moisture originally in the timber.

*Determination of Moisture.*—This is conveniently accomplished by boring a hole through the test piece and weighing the shaving immediately, and again after drying in an oven at about  $212^{\circ}$  F.

**195. Important Series of Timber Tests.**—The first thoroughly scientific tests of timber with records of the moisture are due to Bauschinger, who adopted a standard of 15 per cent. of moisture reckoned on the weight of dried timber. Some account of these experiments and their results is to be found in Unwin's "Testing of Materials."

America is a great timber-growing country, and most of the important work on timber testing has been carried out there under Government departments. An account of many tests on wooden beams and columns made for the U.S. Government may be found in Lanza's "Applied Mechanics." Many inquiries into the strength of timber have been made for the U.S. Department of Agriculture under the Bureau of Forestry, chiefly under the direction of the late Prof. J. B. Johnson, in whose "Materials of Construction" a sufficient account of the work may be found. The work has latterly been carried on by Prof. W. K. Hatt, of Purdue University. In Prof. Johnson's tests the standard dryness adopted was 12 per cent. of moisture reckoned as a percentage of the weight of dry timber.

**196. Tension Tests.**—Tension tests of timber have not been found satisfactory for two reasons. Unless the grain is very straight it is not possible to cut a test piece wholly parallel to the grain; if the grain is inclined to the direction of tension fracture takes place by shearing, the failure being due to the small lateral adhesion of the longitudinal layers. Very greatly enlarged ends have to be used for gripping the test pieces or failure takes place either by crushing the ends across the grain or by shearing of the ends along the grain; very large ends leave a correspondingly small section to fracture, and the desirability of breaking large sections has already been mentioned. Strength tests of timber in tension are not of much practical importance, for timber in structures would rarely, if ever, fracture by simple tension, but by shearing or splitting. Along the grain its resistance to fracture by tension is very great, sometimes over 10 tons per square inch.

The variation in modulus of direct elasticity in different timbers is very similar to the variation in ultimate tenacity, and the limit of proportionality between strain and stress occurs practically at the ultimate strength limit. In tests made three months after felling,

Bauschinger found winter-felled timber to be some 25 per cent. stronger than summer-felled, but this difference quickly decreased with seasoning.

The following figures give some rough idea of the tenacity and Young's modulus of different kinds of timber along the grain:—

	Tenacity. Tons per square inch.	Young's modulus E. Tons per square inch.
Oak (British) . . . . .	4 to 8	650
Ash. . . . .	2 to 7	700
Elm . . . . .	2 to 6	500
Teak . . . . .	2 to 7	1000
Yellow pine . . . . .	1 to 2	700
Red pine . . . . .	2 to 6	700
Spruce . . . . .	2 to 3	700

**197. Compression Tests.**—A crushing test of short blocks in the direction of the grain offers the most reliable characteristic test of quality of a sample of timber. Failure generally occurs by a local buckling of the fibres over the whole of an internal surface inclined to the direction of pressure.

Long compression pieces buckle, and fail as in bending tests. Results of many tests of timber struts may be found in Lanza's "Applied Mechanics."

The crushing strength across the grain is much smaller than with it. There is no definite point of failure, and Johnson in his tests took 3 per cent. of indentation as a limit of allowable strain and 15 per cent. as failure of the piece.

The following figures give some idea of the resistance of different kinds of timber to crushing along the grain:—

Oak . . . . .	2 to 4 tons per square inch
Ash . . . . .	4   "   "   "
Yellow pine . . . . .	2 to 2½   "   "   "
Red pine. . . . .	4 to 5   "   "   "

**198. Bending Tests.**—The bending test is probably the commonest for timber, being easily performed without elaborate apparatus. By employing long pieces fairly large sections can be used in tests. As the modulus of elasticity is not high, the deflections are large and therefore easily measurable. Rectangular sections and central loads on beams freely supported at each end are usually employed in flexure tests, and the points of support and loading are protected from local indentation by metal plates to spread the force. Failure may take place by tension, compression, or longitudinal shear along the grain, longitudinal shear stress always being present in flexures (see Art. 71). The presence of a knot or other defect often determines the place and manner of fracture. Prof. Johnson, from his own and Prof. Lanza's tests, takes it as probable that for rectangular wooden beams, the length of which is less than 20 or 10 times their depth, according as the load is uniformly distributed or concentrated at the centre, failure will

be by longitudinal shear, and dimensions should be proportioned on this supposition. For such beams the total load would be independent of the length. Above these lengths the failure may be from longitudinal direct bending stress, which, of course, increases with the length.

The strength factor most usually measured in bending tests of timber is the "modulus of rupture" (see Art. 74) or coefficient of bending strength, viz.—

$$f = \frac{3}{2} \frac{Wl}{bd^2} \text{ (see (6), Art. 63, and Art. 66)}$$

where *W* is the central breaking load, *l* the length of span, *b* the breadth and *d* the depth of the rectangular section, all dimensions being in inches, and the same units of force being used in *f* and *W*.

The limit of proportionality of deflection to load in bending tests is found to occur at a considerable proportion of the total load: the stress calculated as above ( $\frac{3}{2} \frac{Wl}{bd^2}$ ) at this load, agrees with the ultimate crushing strength as found by a direct crushing test along the grain.

Young's modulus, as determined by bending tests, increases and decreases with the crushing and the bending strength or modulus of rupture, and determined by plotting loads and deflections within the limit of proportionality, Bauschinger considered this modulus of elasticity to be a good indication of the value of timber for structural purposes. The following figures give average values of the modulus of rupture or coefficient of bending strength for various kinds of timber:—

Ash . . . . .	5 to 6 tons per square inch
Elm . . . . .	4 to 5 " " "
Oak . . . . .	5 to 6 " " "
Yellow pine (American) . . . . .	4 to 5 " " "
Red pine (American) . . . . .	3 to 4 " " "
Teak . . . . .	6 to 8 " " "
Spruce . . . . .	4 to 5 " " "

**199. Shearing Tests.**—Shear stress in any plane being always accompanied by shear stress at right angles to it, shearing of timber always takes place along the grain, separating but not rupturing the fibres. This, as already mentioned, is a common method of failure in wooden beams; the shear stress at the neutral axis of a beam of rectangular section is, by Art. 71—

$$\frac{3}{2} \frac{F}{bd} \text{ . . . . . (1)}$$

where *F* is the shearing force on a section of breadth *b* and depth *d*. In the case of a beam carrying a central load *W*, and supported at each end, this becomes—

$$\frac{3}{4} \frac{W}{bd} \text{ . . . . . (2)}$$

Direct shearing experiments along the grain generally show rather greater strength than values calculated by (2) from beams which fail by shearing. This is to be expected from the fact that in shearing

experiments the plane of shear is arbitrarily selected, while in bending tests the failure will take place in the weakest place in the neighbourhood of the neutral plane, where there is the greatest intensity of shear stress.

The results of tests at the Watertown Arsenal on the shearing strength along the grain give the following strengths :—

Ash . . . . .	458 to 700 pounds per square inch
Oak . . . . .	726 to 999   "   "   "
Yellow pine . . . . .	286 to 415   "   "   "
Spruce . . . . .	253 to 374   "   "   "

**200. Prolonged Loading of Timber.**—Under heavy loads timber continuously deforms, and loads in excess of about half those required to produce failure when quickly applied will be sufficient to cause fracture if applied for a length of time. The time elapsing before rupture occurs increases as the load diminishes, permanent resistance being offered to about half the breaking load of an ordinary test.



FIG. 244.—Method of capping wire ropes.

(From Goodman's "Mechanics applied to Engineering.")

**201. Strength of Wire Ropes.**—The great tenacity of drawn wire is utilised for heavy loads in the form of wire ropes. In addition to their flexibility, which allows ropes to bend round pulleys, steel-wire ropes have generally a much greater strength than bars of steel of the same cross-sectional area and weight. As shown by tension tests of separate wires and whole ropes, the rope does not develop the full strength of all the wires. This probably arises mainly from the fact that in the rope some wires are initially lighter than others, and consequently take an undue proportion of the load.

For tensile tests of wire ropes it is important to grip the ends without damaging them, or fracture will occur at the socket. A very satisfactory method, recommended by Prof. Goodman, is shown in Fig. 244. The rope is tightly bound with fine wire about 5 inches from each end, and the length of rope between these bindings is tightly bound with tarred band to keep the strands in position; the ends are then frayed out, cleaned, and the wires turned over into hooks at the ends. A hard alloy of lead and antimony is then cast on the ends in the form of conical caps, which are received in split conical dies in the shackles of the testing machine. The conical dies may conveniently be used as moulds for casting on the metal caps.

## ANSWERS TO EXAMPLES

### EXAMPLES I.

- (1) 3·96 tons per square inch ; 13,700 tons per square inch ; 1·98 ton per square inch.
- (2)  $20^{\circ} 54\frac{1}{2}'$  ; 2·62 tons per square inch ; 2·80 tons per square inch.
- (3) 3·27 tons per square inch ; 3·60 tons per square inch.
- (4) 0·0318 inch.
- (5) 23,200,000 lbs. per square inch ; 3·385.
- (6) 3·5 tons per square inch ; 0·866 ton per square inch : 3·60 tons per square inch inclined  $76^{\circ} 5'$  to the plane.
- (7)  $32^{\circ} 5'$  and 3·54 tons per square inch, or  $72^{\circ}$  and 2·27 tons per square inch.
- (8) 4·58 tons per square inch  $40^{\circ} 9'$  to plane ; 4 tons per square inch.
- (9) 8·12 tons per square inch ; normal of plane inclined  $38^{\circ}$  to axis of 5-ton stress.
- (10) 6·65 tons per square inch ; normal of plane inclined  $22\frac{1}{2}^{\circ}$  to axis of 5-ton stress.
- (11) 4·828 tons per square inch tensile on plane inclined  $22\frac{1}{2}^{\circ}$  to cross-section. 0·828 ton per square inch compressive on plane inclined  $67\frac{1}{2}^{\circ}$  to cross-section.
- (12) 4·16 and 3·16 tons per square inch.
- (13) 4·375 tons per square inch.
- (14)  $\frac{m^2 - m - 3}{m(m - 1)}$ .
- (15)  $\frac{m^2 - 1}{m^2}$ .
- (16)  $\frac{1}{2000}$  increase.
- (17) 19,556 lbs. per square inch (steel) ; 10,222 lbs. per square inch (brass) ; 48·89 per cent.

### EXAMPLES II.

- (1) 32·4 and 21·6 tons per square inch ; 23·5 per cent. ; 13,120 tons per square inch.
- (2) (a) 15·77 tons ; (b) 6·91 tons.
- (3) 10·26 tons per square inch.
- (4) (a) 4000 lbs. per square inch in each ; (b) 11,080 lbs. per square inch (steel), 448 lbs. per square inch (brass) ; 92·3 per cent.
- (5) 2·1 tons per square inch.

## EXAMPLES III.

- (1) 7'03 inch-tons.
- (2) 620 inch-pounds.
- (3) 2760 and 16'26 inch-pounds.
- (4) 8 tons per square inch; 0'0738 inch; 4'06 tons.
- (5) (a) 55 tons; 4'07 square inches; (b) 25 tons: 1'85 square inches.
- (6) 5'46 tons per square inch.
- (7) 3'50 inches.
- (8) 12'68 tons per square inch; 40 per cent. more.

## EXAMPLES IV.

- (1) 158 tons-feet; 20 tons; 50 tons-feet; 14 tons.
- (2) 2650 tons-feet.
- (3) 8 tons-feet; 6 feet from left end; 9'75 tons-feet.
- (4) 10'958 feet from left support; 88'1 tons-feet; 87 tons-feet.
- (5)  $\frac{1}{\sqrt{3}}l$  feet;  $\frac{wl^2}{9\sqrt{3}}$  tons-feet; 10'4 feet; 41'5 tons-feet.
- (6) 11'76 feet from A.
- (7) 13'1 feet from A.
- (8) 32 and 40 tons-feet; 3'05 feet from supports.
- (9) 0'207l and 0'293l from ends.
- (10) 4'6 tons-feet; 0'5 tons-feet; 4'9 feet from left support; 4'74 feet from right support.
- (11) 13 tons-feet; 2'89 feet from left support; 1'46 feet from right support.
- (12) 4'8 tons per square inch.
- (13) 217'5 tons-inches.
- (14) 15'625 tons; 7'812 tons.
- (15) 937'5 feet; 253'2 tons-inches.

## EXAMPLES V.

- (1) 1470 lbs. per square inch; 609'5 feet.
- (2)  $3\frac{1}{8}$  inches.
- (3) 13'1 inches.
- (4) 1'414.
- (5) 12 feet.
- (6) 3'27 to 1.
- (7) 7 tons per square inch.
- (8) 21,750 lb.-inches.
- (9) 5'96 (inches)<sup>4</sup>.
- (10) 4'57 inches; 930 (inches)<sup>4</sup>; 1'36 ton; 1'95 ton per square inch.
- (11) 1437 lbs.; 6930 lbs. per square inch.
- (12) 0'63 square inch; 386 lbs.
- (13) 4'65 square inches.
- (14) 0'565 square inch; 14,580 lbs. per square inch.
- (15) 3 square inches; 18,000 lbs. per square inch.
- (16) 9580 lbs. per square inch; 1,040,000 lb.-inches.
- (17) 351,900 lb.-inches; 18,000 lbs. per square inch.
- (18) 1'867.
- (19) 5'80 tons per square inch; 3'93.
- (21) 4'68 tons per square inch tension inclined 53° 44' to section; 2'60 tons per square inch inclined 36° 46' to section.
- (22) 15'34 ton-inches.

## EXAMPLES VI.

- (1) 0.073 inch.  
 (2) 4.96 tons; 4.74 tons per square inch; 7.94 tons; 3.79 tons per square inch.
- (3)  $\frac{1}{384} \frac{Wl^3}{EI}$ ;  $\frac{W}{2}$   
 $1 + \frac{48EI}{el^3}$ .
- (4) 3 inches (nearly) from centre of span; 0.262 inch.
- (5)  $\frac{5}{8}W$ ;  $\frac{7}{8} \frac{Wl^3}{EI}$ .
- (6)  $\frac{5}{18}W$ ;  $\frac{5}{32}Wl$ ;  $\frac{3}{18}Wl$ ;  $\frac{1}{\sqrt{5}}l$  from free end;  $\frac{1}{48\sqrt{5}} \frac{Wl^3}{EI}$ ; 0.2038 W.
- (7)  $\frac{1}{2}$ .
- (8)  $\frac{1}{30} \frac{wl^4}{EI}$ .
- (9) 0.134 inch; 0.148 inch; 9.25 inches from centre; 0.148 inch
- (10) 9.18 tons; 3.3 tons.
- (11) 8.8 inches from centre; 0.342 inch.
- (12) 12.083 tons (centre); 3.958 tons (ends).
- (13) 0.414; 0.68.
- (14) 0.29; 0.337; 0.644.
- (15)  $\frac{4}{3}$ ;  $\frac{1}{2}$ .
- (16) 0.0186 inch; 0.224 inch; 0.0181 inch (upward); 9.87 feet.
- (17) 0.0988; 0.073 inch (upward); 0.409 inch; 4.63 feet to left of D.
- (18)  $0.544 \frac{Wl^3}{EI_0}$ .
- (19) 2.98 inches.
- (20)  $0.0241 \frac{Wl^3}{EI_0}$ .
- (21)  $0.0153 \frac{Wl^3}{EI_0}$ .
- (22) 4; 0.4096 inch; 176 inches.
- (23) 2.35 tons; 16.92 tons per square inch.

## EXAMPLES VII.

- (1) 6.55 tons per square inch; 0.152 inch.
- (2)  $\frac{3}{80}wl^2$ ;  $\frac{1}{20}wl^2$ ;  $\frac{3}{20}wl$ ;  $\frac{7}{30}wl$ ; 0.025  $l$  from centre.
- (3)  $\frac{2}{3}Wl$ ;  $\frac{1}{3}Wl$ ;  $\frac{5}{8} \frac{Wl^3}{EI}$ ;  $\frac{1}{18} \frac{Wl^3}{EI}$ ;  $\frac{2}{3}l$  from ends.
- (4)  $\frac{2}{27}Wl$ ;  $\frac{4}{27}Wl$ ;  $\frac{7}{27}W$ ;  $\frac{20}{27}W$ ;  $\frac{5}{1200} \frac{Wl^3}{EI}$ ;  $\frac{8}{187} \frac{Wl^3}{EI}$ ;  $\frac{4}{3}l$  from light end;  $\frac{1}{300} \frac{Wl^3}{EI}$ ;  $\frac{2}{3}l$  and  $\frac{4}{3}l$  from light end.
- (5) 22.025 tons-feet (left); 19.475 tons-feet (right).
- (6)  $\frac{1}{12}wl^2$  and  $\frac{1}{12}wl^2$ ; 0.182  $l$  and  $\frac{1}{3}l$  from heavy end; 0.443 from heavy end;  $0.00134 \frac{wl^4}{EI}$ .
- (7)  $0.1108Wl$ ;  $0.1392Wl$ ;  $0.007 \frac{Wl^3}{EI}$ .

(8)  $0\cdot0759Wl$ ;  $0\cdot0491Wl$ ;  $0\cdot0037\frac{Wl^3}{EI}$ .

(9)  $0$ ,  $\frac{1}{10}wl^2$ ,  $\frac{1}{10}wl^2$ ,  $0$ ;  $\frac{4}{10}wl$ ,  $\frac{11}{10}wl$ ,  $\frac{11}{10}wl$ ,  $\frac{4}{10}wl$ .

(10)  $0$ ,  $175$  tons-feet,  $125$  tons-feet,  $0$ ;  $24\cdot16$  tons,  $57\cdot083$  tons,  $55$  tons,  $23\cdot75$  tons.

(11)  $7\cdot429$  tons-feet at B,  $4\cdot913$  tons-feet at C; in order A, B, C, D,  $3\cdot45$ ,  $7\cdot34$ ,  $6\cdot39$ ,  $3\cdot82$  tons.

(12) (a) From fixed end,  $\frac{9}{104}wl^2$ ,  $\frac{1}{13}wl^2$ ,  $\frac{11}{104}wl^2$ ,  $0$ ;  $\frac{53}{104}wl$ ,  $\frac{25}{88}wl$ ,  $\frac{53}{88}wl$ ,  $\frac{41}{104}wl$ . (b)  $\frac{1}{12}wl^2$  at each;  $\frac{wl}{2}$  at ends,  $wl$  at inner supports.

(13) In order A, B, C, D,  $6\cdot193$ ,  $5\cdot661$ ,  $5\cdot486$ ,  $0$  tons-feet;  $4\cdot441$ ,  $6\cdot03$ ,  $6\cdot843$ ,  $3\cdot703$  tons.

(14)  $2\cdot94$  and  $8\cdot65$  tons-feet;  $4\cdot01$ ,  $5\cdot60$ ,  $8\cdot32$ ,  $3\cdot07$  tons.

## EXAMPLES VIII.

(1)  $15,625$  pounds per square inch;  $0\cdot815$  inch-pounds.

(2)  $5\cdot43$  and  $0\cdot15$  inch-pounds.

(3)  $\frac{1}{24}\frac{P^2}{E}$ .

(4)  $3\cdot2$  to  $1$ ,  $1$  to  $3$ .

(5)  $780$  cubic inches;  $10$ ;  $0\cdot854$  ton;  $2\cdot34$  inches;  $27$  feet  $1$  inch.

(6)  $7\cdot4$  per cent.

## EXAMPLES IX.

(1)  $1\cdot936$  and  $0\cdot844$  tons per square inch.

(2)  $5\cdot6$  and  $2\cdot4$  tons per square inch.

(3)  $7\cdot417$  and  $6\cdot583$  tons per square inch.

(4)  $14\cdot85$  feet.

(5)  $72\cdot8$  tons.

(6)  $4$  feet  $6\cdot6$  inches.

(7)  $989$  tons.

(8)  $354$  tons.

(9)  $324$  tons.

(10)  $36\cdot6$  tons.

(11)  $121\cdot3$  tons.

(12)  $0\cdot48$  inch.

(13)  $9\cdot5$  inches.

(14)  $2\cdot441$  and  $0\cdot339$  tons per square inch.

(15)  $0\cdot309$  inch.

(16)  $46\cdot3$  inches;  $0\cdot34$  ton per square inch.

(17)  $770$  tons.

(18)  $19\cdot06$  tons;  $5\cdot42$  tons per square inch.

(19)  $2\cdot275$  inches.

(20)  $13\cdot2$  tons;  $4\cdot06$  tons per square inch.

(21)  $4571$  and  $521$  pounds per square inch compression.

(22)  $0\cdot0308$  inch;  $3173$  pounds per square inch.

(23)  $6\cdot81$  tons.

## EXAMPLES X.

(1)  $2\cdot27$  tons per square inch.

(2)  $47,750$  pound-inches;  $3\cdot43^\circ$ .

(3)  $4\cdot11$  inches;  $2\cdot23^\circ$ .



- (4) 9910 pounds per square inch.
- (5) 2'386 tons per square inch ; 1'05°.
- (6) 1'443 and 1'67.
- (7) 0'776 and 0'984.
- (8) 6370 pounds per square inch ; 26°34'.
- (9) 14'63 inches ; 15'34 inches.
- (10) 25'4 H.P.
- (11) 4423 pounds per square inch.
- (12) 6060 pounds per square inch.
- (13)  $30 \times 10^6$  and  $11'8 \times 10^6$  pounds per square inch ; 0'271.
- (14) 1'31 inch ; 7820 pounds per square inch ; 110 pounds.
- (15) 8 feet 6 inches.
- (16) 162'5 pounds ; 1'546 inch.
- (17) 13'96 pounds.
- (18) 47'8 inches ; 1'15 inch.
- (19) 23'9 pound-inches.
- (20) 48 feet ; 0'3684 inch.
- (21) 1'438 inch ; 3'61 inches ; 0'97 inch ; 2'286 inches.
- (22) 3'76° winding up ; 20'14° unwinding ; 4'23° winding up ; 9'28° unwinding.
- (23) 23'1° ; 79'5° ; 14'3° ; 47'7°.

## EXAMPLES XI.

- (1)  $\frac{1}{30}$  inch.
- (2) 173 pounds per square inch.
- (3) 1000 pounds per square inch ; 111 pounds per square inch ; 3120 pounds per square inch.
- (4) 3'09 inches ; 500 pounds per square inch.
- (5) 1539 pounds per square inch.
- (6) 2'18 inches.
- (7) 2'04 inches.
- (8) 14,400 compression ; 10,286 tension ; 14,286 tension, and 10,400 compression at common surface ; all in pounds per square inch.
- (9) 0'00368 inch.
- (10) 16,953 ; 2267 ; 23,545 pounds per square inch.
- (11) 2950 revs. per minute ; 0'0269 inch.
- (12) 1'535 : 1'56 : 1.
- (13) 1070 pounds per square inch.

## EXAMPLES XII.

- (1) 6'67 tons per square inch tension ; 3'94 tons per square inch compression.
- (2) 7922 pounds per square inch tension ; 22,660 pounds per square inch compression.
- (3) 4'53 tons.
- (4) 8'83 and 3'7 tons per square inch.
- (5) 13,733 and 18,620 pounds per square inch.
- (6) 0'003557 inch ; 0'002469 inch.
- (7) 6830 and 12,930 pounds per square inch.
- (8)  $3\frac{1}{2}$  pound-inches ; 6'36 turns ; 66'6 inch-pounds ; 1'91 pounds.
- (9) 31'25 tons ; 8'4 tons-feet.
- (10) 20'83 tons ; 6'51 tons-feet ; 25'1 tons ; 0'57 ton.
- (11) 30'5 tons.

- (12) 9'76 tons, 21'9 tons-feet.  
 (13) 0'43 tons per square inch.  
 (14) Ends, 0'0553Wl;  $\frac{W}{2}$ ; 0'459W. Crown, 0'0757Wl; 0'459lW; zero.  
 (15) 1992 pounds per square inch; 50'5°.  
 (16) 8280 pounds per square inch.  
 (17) 121 feet.  
 (18) 1'2 inch.  
 (19) 4167 pounds per square inch; 39'4°; 8333 pounds per square inch.  
 (20) 4'46 inches; 11,200 pounds per square inch.  
 (21) 79'74 feet; 22'95w pounds; 102'69 pounds

## EXAMPLES XIII.

- (1) 45'5 pounds per square inch.  
 (2) 64'9 pounds per square inch.  
 (3) 75 pounds per square inch.  
 (4) 82'4 pounds per square inch.  
 (5) 9'52 inches.  
 (6) 192 pounds per square inch.

## EXAMPLES XIV.

- (1) 2'45 per second.  
 (2) 33'24 per minute.  
 (3) 22'44 per second.  
 (4) 32 per second.  
 (5) 18'4 per second.  
 (6) 29'9 per second.  
 (7) 1042 revs. per minute.  
 (8) 10,667, 1373, 6270 revs. per minute.  
 (9) 3704 pounds per square inch.  
 (10) 667 per minute.  
 (11) 701 per minute.  
 (12) 651 per minute.

Angle.		Chord.	Sine.	Tangent.	Co-tangent.	Cosine	1.414	1.5708	90°
De-grees.	Radians.								
0°	0	000	0	0	∞	1	1.414	1.5708	90°
1	.0175	.017	.0175	.0175	57.2900	.9998	1.402	1.5533	89
2	.0349	.035	.0349	.0349	28.6363	.9994	1.389	1.5359	88
3	.0524	.052	.0523	.0524	19.0811	.9986	1.377	1.5184	87
4	.0698	.070	.0698	.0699	14.3007	.9976	1.364	1.5010	86
5	.0873	.087	.0872	.0875	11.4301	.9962	1.351	1.4835	85
6	.1047	.105	.1045	.1051	9.5144	.9945	1.338	1.4661	84
7	.1222	.122	.1219	.1223	8.1443	.9925	1.325	1.4486	83
8	.1396	.140	.1392	.1405	7.1154	.9903	1.312	1.4312	82
9	.1571	.157	.1564	.1584	6.3138	.9877	1.299	1.4137	81
10	.1745	.174	.1736	.1763	5.6713	.9848	1.286	1.3963	80
11	.1920	.192	.1908	.1944	5.1446	.9816	1.272	1.3788	79
12	.2094	.209	.2079	.2126	4.7046	.9781	1.259	1.3614	78
13	.2269	.226	.2250	.2309	4.3315	.9744	1.245	1.3439	77
14	.2443	.244	.2419	.2493	4.0108	.9703	1.231	1.3265	76
15	.2618	.261	.2588	.2679	3.7321	.9659	1.218	1.3090	75
16	.2793	.278	.2756	.2867	3.4874	.9613	1.204	1.2915	74
17	.2967	.296	.2924	.3057	3.2709	.9563	1.190	1.2741	73
18	.3142	.313	.3090	.3249	3.0777	.9511	1.176	1.2566	72
19	.3316	.330	.3256	.3443	2.9042	.9455	1.161	1.2392	71
20	.3491	.347	.3420	.3640	2.7475	.9397	1.147	1.2217	70
21	.3665	.364	.3584	.3839	2.6051	.9336	1.133	1.2043	69
22	.3840	.382	.3746	.4040	2.4751	.9272	1.118	1.1868	68
23	.4014	.399	.3907	.4245	2.3559	.9205	1.104	1.1694	67
24	.4189	.416	.4067	.4452	2.2460	.9135	1.089	1.1519	66
25	.4363	.433	.4226	.4663	2.1445	.9063	1.075	1.1345	65
26	.4538	.450	.4384	.4877	2.0503	.8988	1.060	1.1170	64
27	.4712	.467	.4540	.5095	1.9626	.8910	1.045	1.0996	63
28	.4887	.484	.4695	.5317	1.8807	.8829	1.030	1.0821	62
29	.5061	.501	.4848	.5543	1.8040	.8746	1.015	1.0647	61
30	.5236	.518	.5000	.5774	1.7321	.8660	1.000	1.0472	60
31	.5411	.534	.5150	.6009	1.6643	.8572	.985	1.0297	59
32	.5585	.551	.5299	.6249	1.6003	.8480	.970	1.0123	58
33	.5760	.568	.5446	.6494	1.5399	.8387	.954	.9948	57
34	.5934	.585	.5592	.6745	1.4826	.8290	.939	.9774	56
35	.6109	.601	.5736	.7002	1.4281	.8192	.923	.9599	55
36	.6283	.618	.5878	.7265	1.3764	.8090	.908	.9425	54
37	.6458	.635	.6018	.7536	1.3270	.7986	.892	.9250	53
38	.6632	.651	.6157	.7813	1.2799	.7880	.877	.9076	52
39	.6807	.668	.6293	.8098	1.2349	.7771	.861	.8901	51
40	.6981	.684	.6428	.8391	1.1918	.7660	.845	.8727	50
41	.7156	.700	.6561	.8693	1.1504	.7547	.829	.8552	49
42	.7330	.717	.6691	.9004	1.1106	.7431	.813	.8378	48
43	.7505	.733	.6820	.9325	1.0724	.7314	.797	.8203	47
44	.7679	.749	.6947	.9657	1.0355	.7193	.781	.8029	46
45°	.7854	.765	.7071	1.0000	1.0000	.7071	.765	.7854	45°
			Cosine.	Co-tangent.	Tangent.	Sine.	Chord.	Radians.	De-grees.
								Angle.	

	0	1	2	3	4	5	6	7	8	9	1234	5	6789
10	0000	0043	0086	0128	0170	0212	0253	0294	0334	0374	4 9 13 17 4 8 12 16	21	25 30 34 38 24 28 32 37
11	0414	0453	0492	0531	0569	0607	0645	0682	0719	0755	4 8 12 15 4 7 11 15	19	23 27 31 35 22 26 30 33
12	0792	0828	0864	0899	0934	0969	1004	1038	1072	1106	3 7 11 14 3 7 10 14	18	21 25 28 32 20 24 27 31
13	1139	1173	1206	1239	1271	1303	1335	1367	1399	1430	3 7 10 13 3 7 10 12	16	20 23 26 30 19 22 25 29
14	1461	1492	1523	1553	1581	1614	1644	1673	1703	1732	3 6 9 12 3 6 9 12	15	18 21 24 28 17 20 23 26
15	1761	1790	1818	1847	1875	1903	1931	1959	1987	2014	3 6 9 11 3 5 8 11	14	17 20 23 26 16 19 22 25
16	2041	2068	2095	2122	2148	2175	2201	2227	2253	2279	3 5 8 11 3 5 8 10	14	16 19 22 24 15 18 21 23
17	2304	2330	2355	2380	2405	2430	2455	2480	2504	2529	3 5 8 10 2 5 7 10	13	15 18 20 23 12 15 17 19 22
18	2553	2577	2601	2625	2648	2672	2695	2718	2742	2765	2 5 7 9 2 5 7 9	12	14 16 19 21 14 16 18 21
19	2788	2810	2833	2856	2878	2900	2923	2945	2967	2989	2 4 7 9 2 4 6 8	11	13 16 18 20 13 15 17 19
20	3010	3032	3054	3075	3096	3118	3139	3160	3181	3201	2 4 6 8	11	13 15 17 19
21	3222	3243	3263	3284	3304	3324	3345	3365	3385	3404	2 4 6 8	10	12 14 16 18
22	3424	3444	3464	3483	3502	3522	3541	3560	3579	3598	2 4 6 8	10	12 14 15 17
23	3617	3636	3655	3674	3692	3711	3729	3747	3766	3784	2 4 6 7	9	11 13 15 17
24	3802	3820	3838	3856	3874	3892	3909	3927	3945	3962	2 4 5 7	9	11 12 14 16
25	3979	3997	4014	4031	4048	4065	4082	4099	4116	4133	2 3 5 7	9	10 12 14 15
26	4150	4166	4183	4200	4216	4232	4249	4265	4281	4298	2 3 5 7	8	10 11 13 15
27	4314	4330	4346	4362	4378	4393	4409	4425	4440	4456	2 3 5 6	8	9 11 13 14
28	4472	4487	4502	4518	4533	4548	4564	4579	4594	4609	2 3 5 6	8	9 11 12 14
29	4624	4639	4654	4669	4683	4698	4713	4728	4742	4767	1 3 4 6	7	9 10 12 13
30	4771	4786	4800	4814	4829	4843	4857	4871	4886	4900	1 3 4 6	7	9 10 11 13
31	4914	4928	4942	4955	4969	4983	4997	5011	5024	5038	1 3 4 6	7	8 10 11 12
32	5051	5065	5079	5092	5105	5119	5132	5145	5159	5172	1 3 4 5	7	8 9 11 12
33	5185	5198	5211	5224	5237	5250	5263	5276	5289	5302	1 3 4 5	6	8 9 10 12
34	5315	5328	5340	5353	5366	5378	5391	5403	5416	5428	1 3 4 5	6	8 9 10 11
35	5441	5453	5465	5478	5490	5502	5514	5527	5539	5551	1 2 4 5	6	7 9 10 11
36	5563	5575	5587	5599	5611	5623	5635	5647	5658	5670	1 2 4 5	6	7 8 10 11
37	5682	5694	5705	5717	5729	5740	5752	5763	5775	5786	1 2 3 5	6	7 8 9 10
38	5798	5809	5821	5832	5843	5855	5866	5877	5888	5899	1 2 3 5	6	7 8 9 10
39	5911	5922	5933	5944	5955	5966	5977	5988	5999	6010	1 2 3 4	5	7 8 9 10
40	6021	6031	6042	6053	6064	6075	6085	6096	6107	6117	1 2 3 4	5	6 8 9 10
41	6128	6138	6149	6160	6170	6180	6191	6201	6212	6222	1 2 3 4	5	6 7 8 9
42	6232	6243	6253	6263	6274	6284	6294	6304	6314	6325	1 2 3 4	5	6 7 8 9
43	6335	6345	6355	6365	6375	6385	6395	6405	6415	6425	1 2 3 4	5	6 7 8 9
44	6436	6444	6454	6464	6474	6484	6493	6503	6513	6522	1 2 3 4	5	6 7 8 9
45	6532	6542	6551	6561	6571	6580	6590	6599	6609	6618	1 2 3 4	5	6 7 8 9
46	6628	6637	6646	6656	6665	6675	6684	6693	6702	6712	1 2 3 4	5	6 7 7 8
47	6721	6730	6739	6749	6758	6767	6776	6785	6794	6803	1 2 3 4	5	5 6 7 8
48	6812	6821	6830	6839	6848	6857	6866	6875	6884	6893	1 2 3 4	4	5 6 7 8
49	6902	6911	6920	6928	6937	6946	6955	6964	6972	6981	1 2 3 4	4	5 6 7 8
50	6990	6998	7007	7016	7024	7033	7042	7050	7059	7067	1 2 3 3	4	5 6 7 8

	0	1	2	3	4	5	6	7	8	9	1234	5	6789
51	7076	7084	7093	7101	7110	7118	7126	7135	7143	7152	1 2 3 3	4	5 6 7 8
52	7160	7168	7177	7185	7193	7202	7210	7218	7226	7235	1 2 2 3	4	5 6 7 7
53	7243	7251	7259	7267	7275	7284	7292	7300	7308	7316	1 2 2 3	4	5 6 6 7
54	7324	7332	7340	7348	7356	7364	7372	7380	7388	7396	1 2 2 3	4	5 6 6 7
55	7404	7412	7419	7427	7435	7443	7451	7459	7466	7474	1 2 2 3	4	5 5 6 7
56	7482	7490	7497	7505	7513	7520	7528	7536	7543	7551	1 2 2 3	4	5 5 6 7
57	7559	7566	7574	7582	7589	7597	7604	7612	7619	7627	1 2 2 3	4	5 5 6 7
58	7634	7642	7649	7657	7664	7672	7679	7686	7694	7701	1 1 2 3	4	4 5 6 7
59	7709	7716	7723	7731	7738	7745	7752	7760	7767	7774	1 1 2 3	4	4 5 6 7
60	7782	7789	7796	7803	7810	7818	7825	7832	7839	7846	1 1 2 3	4	4 5 6 6
61	7853	7860	7868	7875	7882	7889	7896	7903	7910	7917	1 1 2 3	4	4 5 6 6
62	7924	7931	7938	7945	7952	7959	7966	7973	7980	7987	1 1 2 3	3	4 5 6 6
63	7993	8000	8007	8014	8021	8028	8035	8041	8048	8055	1 1 2 3	3	4 5 5 6
64	8062	8069	8076	8082	8089	8096	8102	8109	8116	8122	1 1 2 3	3	4 5 5 6
65	8129	8136	8142	8149	8156	8162	8169	8176	8182	8189	1 1 2 3	3	4 5 5 6
66	8195	8202	8209	8216	8222	8228	8235	8241	8248	8254	1 1 2 3	3	4 5 5 6
67	8261	8267	8274	8280	8287	8293	8299	8306	8312	8319	1 1 2 3	3	4 5 5 6
68	8325	8331	8338	8344	8351	8357	8363	8370	8376	8382	1 1 2 3	3	4 4 5 6
69	8388	8395	8401	8407	8414	8420	8426	8432	8439	8445	1 1 2 2	3	4 4 5 6
70	8451	8457	8463	8470	8476	8482	8488	8494	8500	8506	1 1 2 2	3	4 4 5 6
71	8513	8519	8525	8531	8537	8543	8549	8555	8561	8567	1 1 2 2	3	4 4 5 5
72	8573	8579	8585	8591	8597	8603	8609	8615	8621	8627	1 1 2 2	3	4 4 5 5
73	8633	8639	8645	8651	8657	8663	8669	8675	3681	8686	1 1 2 2	3	4 4 5 5
74	8692	8698	8704	8710	8716	8722	8727	8733	3739	8745	1 1 2 2	3	4 4 5 5
75	8751	8756	8762	8768	8774	8779	8785	8791	8797	8802	1 1 2 2	3	3 4 5 5
76	8808	8814	8820	8825	8831	8837	8842	8848	8854	8859	1 1 2 2	3	3 4 5 5
77	8865	8871	8876	8882	8887	8893	8899	8904	8910	8915	1 1 2 2	3	3 4 4 5
78	8921	8927	8932	8938	8943	8949	8954	8960	8965	8971	1 1 2 2	3	3 4 4 5
79	8976	8982	8987	8993	8998	9004	9009	9015	9020	9025	1 1 2 2	3	3 4 4 5
80	9031	9036	9042	9047	9053	9058	9063	9069	9074	9079	1 1 2 2	3	3 4 4 5
81	9085	9090	9096	9101	9106	9112	9117	9122	9128	9133	1 1 2 2	3	3 4 4 5
82	9138	9143	9149	9154	9159	9165	9170	9175	9180	9186	1 1 2 2	3	3 4 4 5
83	9191	9196	9201	9206	9212	9217	9222	9227	9232	9238	1 1 2 2	3	3 4 4 5
84	9243	9248	9253	9258	9263	9269	9274	9279	9284	9289	1 1 2 2	3	3 4 4 5
85	9294	9299	9304	9309	9316	9320	9325	9330	9335	9340	1 1 2 2	3	3 4 4 5
86	9345	9350	9355	9360	9365	9370	9375	9380	9385	9390	1 1 2 2	3	3 4 4 5
87	9395	9400	9405	9410	9415	9420	9425	9430	9435	9440	0 1 1 2	2	3 3 4 4
88	9445	9450	9455	9460	9465	9469	9474	9479	9484	9489	0 1 1 2	2	3 3 4 4
89	9494	9499	9504	9509	9513	9518	9523	9528	9533	9538	0 1 1 2	2	3 3 4 4
90	9542	9547	9552	9557	9562	9566	9571	9576	9581	9586	0 1 1 2	2	3 3 4 4
91	9590	9595	9600	9605	9609	9614	9619	9624	9628	9633	0 1 1 2	2	3 3 4 4
92	9638	9643	9647	9652	9657	9661	9666	9671	9676	9680	0 1 1 2	2	3 3 4 4
93	9685	9689	9694	9699	9703	9708	9713	9717	9722	9727	0 1 1 2	2	3 3 4 4
94	9731	9736	9741	9745	9750	9754	9759	9763	9768	9773	0 1 1 2	2	3 3 4 4
95	9777	9782	9786	9791	9795	9800	9805	9809	9814	9818	0 1 1 2	2	3 3 4 4
96	9823	9827	9832	9836	9841	9845	9850	9854	9859	9863	0 1 1 2	2	3 3 4 4
97	9868	9872	9877	9881	9886	9890	9894	9899	9903	9908	0 1 1 2	2	3 3 4 4
98	9912	9917	9921	9926	9930	9934	9939	9943	9948	9952	0 1 1 2	2	3 3 4 4
99	9956	9961	9965	9969	9974	9978	9983	9987	9991	9996	0 1 1 2	2	-3 3 3 4

	0	1	2	3	4	5	6	7	8	9	1	2	3	4	5	6	7	8	9
·00	1000	1002	1005	1007	1009	1012	1014	1016	1019	1021	0	0	1	1	1	1	2	2	2
·01	1023	1026	1028	1030	1033	1035	1038	1040	1042	1045	0	0	1	1	1	1	1	2	2
·02	1047	1050	1052	1054	1057	1059	1062	1064	1067	1069	0	0	1	1	1	1	1	2	2
·03	1072	1074	1076	1079	1081	1084	1086	1089	1091	1094	0	0	1	1	1	1	1	2	2
·04	1096	1099	1102	1104	1107	1109	1112	1114	1117	1119	0	1	1	1	1	1	1	2	2
·05	1122	1125	1127	1130	1132	1135	1138	1140	1143	1146	0	1	1	1	1	1	1	2	2
·06	1148	1151	1153	1156	1159	1161	1164	1167	1169	1172	0	1	1	1	1	1	1	2	2
·07	1175	1178	1180	1183	1186	1189	1191	1194	1197	1199	0	1	1	1	1	1	1	2	2
·08	1202	1205	1208	1211	1213	1216	1219	1222	1225	1227	0	1	1	1	1	1	1	2	2
·09	1230	1233	1236	1239	1242	1245	1247	1250	1253	1256	0	1	1	1	1	1	1	2	2
·10	1259	1262	1265	1268	1271	1274	1276	1279	1282	1285	0	1	1	1	1	1	1	2	2
·11	1288	1291	1294	1297	1300	1303	1306	1309	1312	1315	0	1	1	1	1	2	2	2	2
·12	1318	1321	1324	1327	1330	1334	1337	1340	1343	1346	0	1	1	1	1	2	2	2	2
·13	1349	1352	1355	1358	1361	1365	1368	1371	1374	1377	0	1	1	1	1	2	2	2	2
·14	1380	1384	1387	1390	1393	1396	1400	1403	1406	1409	0	1	1	1	1	2	2	2	2
·15	1413	1416	1419	1422	1426	1429	1432	1435	1439	1442	0	1	1	1	1	2	2	2	2
·16	1445	1449	1452	1455	1459	1462	1466	1469	1472	1476	0	1	1	1	1	2	2	2	2
·17	1479	1483	1486	1489	1493	1496	1500	1503	1507	1510	0	1	1	1	1	2	2	2	2
·18	1514	1517	1521	1524	1528	1531	1535	1538	1542	1545	0	1	1	1	1	2	2	2	2
·19	1549	1552	1556	1560	1563	1567	1570	1574	1578	1581	0	1	1	1	1	2	2	2	2
·20	1585	1589	1592	1596	1600	1603	1607	1611	1614	1618	0	1	1	1	1	2	2	2	2
·21	1622	1626	1629	1633	1637	1641	1644	1648	1652	1656	0	1	1	1	2	2	2	2	2
·22	1660	1663	1667	1671	1675	1679	1683	1687	1690	1694	0	1	1	1	2	2	2	2	2
·23	1698	1702	1706	1710	1714	1718	1722	1726	1730	1734	0	1	1	1	2	2	2	2	2
·24	1738	1742	1746	1750	1754	1758	1762	1766	1770	1774	0	1	1	1	2	2	2	2	2
·25	1778	1782	1786	1791	1795	1799	1803	1807	1811	1816	0	1	1	1	2	2	2	2	2
·26	1820	1824	1828	1832	1837	1841	1845	1849	1854	1858	0	1	1	1	2	2	2	2	2
·27	1862	1866	1871	1875	1879	1884	1888	1892	1897	1901	0	1	1	1	2	2	2	2	2
·28	1905	1910	1914	1919	1923	1928	1932	1936	1941	1945	0	1	1	1	2	2	2	2	2
·29	1950	1954	1959	1963	1968	1972	1977	1982	1986	1991	0	1	1	1	2	2	2	2	2
·30	1995	2000	2004	2009	2014	2018	2023	2028	2032	2037	0	1	1	1	2	2	2	2	2
·31	2042	2046	2051	2056	2061	2065	2070	2075	2080	2084	0	1	1	1	2	2	2	2	2
·32	2089	2094	2099	2104	2109	2113	2118	2123	2128	2133	0	1	1	1	2	2	2	2	2
·33	2138	2143	2148	2153	2158	2163	2168	2173	2178	2183	0	1	1	1	2	2	2	2	2
·34	2188	2193	2198	2203	2208	2213	2218	2223	2228	2234	1	1	1	1	2	2	2	2	2
·35	2239	2244	2249	2254	2259	2265	2270	2275	2280	2286	1	1	1	1	2	2	2	2	2
·36	2291	2296	2301	2307	2312	2317	2323	2328	2333	2339	1	1	1	1	2	2	2	2	2
·37	2344	2350	2355	2360	2366	2371	2377	2382	2388	2393	1	1	1	1	2	2	2	2	2
·38	2399	2404	2410	2415	2421	2427	2432	2438	2443	2449	1	1	1	1	2	2	2	2	2
·39	2455	2460	2466	2472	2477	2483	2489	2495	2500	2506	1	1	1	1	2	2	2	2	2
·40	2512	2518	2523	2529	2535	2541	2547	2553	2559	2564	1	1	1	1	2	2	2	2	2
·41	2570	2576	2582	2588	2594	2600	2606	2612	2618	2624	1	1	1	1	2	2	2	2	2
·42	2630	2636	2642	2649	2655	2661	2667	2673	2679	2685	1	1	1	1	2	2	2	2	2
·43	2692	2698	2704	2710	2716	2723	2729	2735	2742	2748	1	1	1	1	2	2	2	2	2
·44	2754	2761	2767	2773	2780	2786	2793	2799	2805	2812	1	1	1	1	2	2	2	2	2
·45	2818	2825	2831	2838	2844	2851	2858	2864	2871	2877	1	1	1	1	2	2	2	2	2
·46	2884	2891	2897	2904	2911	2917	2924	2931	2938	2944	1	1	1	1	2	2	2	2	2
·47	2951	2958	2965	2972	2979	2985	2992	2999	3006	3013	1	1	1	1	2	2	2	2	2
·48	3020	3027	3034	3041	3048	3055	3062	3069	3076	3083	1	1	1	1	2	2	2	2	2
·49	3090	3097	3105	3112	3119	3126	3133	3141	3148	3155	1	1	1	1	2	2	2	2	2

	0	1	2	3	4	5	6	7	8	9	1	2	3	4	5	6	7	8	9
50	3162	3170	3177	3184	3192	3199	3206	3214	3221	3228	1	1	2	3	4	4	5	6	7
51	3236	3243	3251	3258	3266	3273	3281	3289	3296	3304	1	2	2	3	4	5	5	6	7
52	3311	3319	3327	3334	3342	3350	3357	3365	3373	3381	1	2	2	3	4	5	5	6	7
53	3388	3396	3404	3412	3420	3428	3436	3443	3451	3459	1	2	2	3	4	5	5	6	7
54	3467	3475	3483	3491	3499	3508	3516	3524	3532	3540	1	2	2	3	4	5	5	6	7
55	3548	3556	3565	3573	3581	3589	3597	3606	3614	3622	1	2	2	3	4	5	5	6	7
56	3631	3639	3648	3656	3664	3673	3681	3690	3698	3707	1	2	3	3	4	5	5	6	7
57	3715	3724	3733	3741	3750	3758	3767	3776	3784	3793	1	2	3	3	4	5	5	6	7
58	3802	3811	3819	3828	3837	3846	3855	3864	3873	3882	1	2	3	4	4	5	5	6	7
59	3890	3899	3908	3917	3926	3936	3945	3954	3963	3972	1	2	3	4	5	5	5	6	7
60	3981	3990	3999	4009	4018	4027	4036	4046	4055	4064	1	2	3	4	5	6	6	7	8
61	4074	4083	4093	4102	4111	4121	4130	4140	4150	4159	1	2	3	4	5	6	6	7	8
62	4169	4178	4188	4198	4207	4217	4227	4236	4246	4256	1	2	3	4	5	6	6	7	8
63	4266	4276	4285	4295	4305	4315	4325	4335	4345	4355	1	2	3	4	5	6	6	7	8
64	4365	4375	4385	4395	4406	4416	4426	4436	4446	4457	1	2	3	4	5	6	6	7	8
65	4467	4477	4487	4498	4508	4519	4529	4539	4550	4560	1	2	3	4	5	6	6	7	8
66	4571	4581	4592	4603	4613	4624	4634	4645	4656	4667	1	2	3	4	5	6	6	7	8
67	4677	4688	4699	4710	4721	4732	4742	4753	4764	4776	1	2	3	4	5	7	7	8	9
68	4786	4797	4808	4819	4831	4842	4853	4864	4875	4887	1	2	3	4	6	7	7	8	9
69	4898	4909	4920	4932	4943	4956	4966	4977	4989	5000	1	2	3	5	6	7	7	8	9
70	5012	5023	5035	5047	5058	5070	5082	5093	5106	5117	1	2	4	5	6	7	7	8	9
71	5129	5140	5152	5164	5176	5188	5200	5212	5224	5236	1	2	4	5	6	7	7	8	10
72	5248	5260	5272	5284	5297	5309	5321	5333	5346	5358	1	2	4	5	6	7	7	9	10
73	5370	5383	5395	5408	5420	5433	5445	5458	5470	5483	1	3	4	5	6	8	8	9	10
74	5495	5508	5521	5534	5546	5559	5572	5585	5598	5610	1	3	4	5	6	8	8	9	10
75	5623	5636	5649	5662	5675	5689	5702	5715	5728	5741	1	3	4	5	7	8	8	9	10
76	5754	5768	5781	5794	5808	5821	5834	5848	5861	5875	1	3	4	5	7	8	8	9	11
77	5888	5902	5916	5929	5943	5957	5970	5984	5998	6012	1	3	4	5	7	8	8	10	11
78	6026	6039	6053	6067	6081	6095	6109	6124	6138	6152	1	3	4	6	7	8	8	10	11
79	6166	6180	6194	6209	6223	6237	6252	6266	6281	6295	1	3	4	6	7	9	8	10	11
80	6310	6324	6339	6353	6368	6383	6397	6412	6427	6442	1	3	4	6	7	9	9	10	12
81	6457	6471	6486	6501	6516	6531	6546	6561	6577	6592	2	3	5	6	8	9	9	11	12
82	6607	6622	6637	6653	6668	6683	6699	6714	6730	6745	2	3	5	6	8	9	9	11	12
83	6761	6776	6792	6808	6823	6839	6855	6871	6887	6902	2	3	5	6	8	9	9	11	13
84	6918	6934	6950	6966	6982	6998	7015	7031	7047	7063	2	3	5	6	8	10	9	11	13
85	7079	7096	7112	7129	7145	7161	7178	7194	7211	7228	2	3	5	7	8	10	10	12	13
86	7244	7261	7278	7295	7311	7328	7345	7362	7379	7396	2	3	5	7	8	10	10	12	13
87	7413	7430	7447	7464	7482	7499	7516	7534	7551	7568	2	3	5	7	9	10	10	12	14
88	7586	7603	7621	7638	7656	7674	7691	7709	7727	7745	2	4	5	7	9	11	10	12	14
89	7762	7780	7798	7816	7834	7852	7870	7889	7907	7925	2	4	5	7	9	11	10	12	14
90	7943	7962	7980	7998	8017	8035	8054	8072	8091	8110	2	4	6	7	9	11	11	13	15
91	8128	8147	8166	8185	8204	8222	8241	8260	8279	8299	2	4	6	8	9	11	11	13	15
92	8318	8337	8356	8375	8395	8414	8433	8453	8472	8492	2	4	6	8	10	12	11	13	15
93	8511	8531	8551	8570	8590	8610	8630	8650	8670	8690	2	4	6	8	10	12	11	13	15
94	8710	8730	8750	8770	8790	8810	8831	8851	8872	8892	2	4	6	8	10	12	11	13	15
95	8913	8933	8954	8974	8995	9016	9036	9057	9078	9099	2	4	6	8	10	12	11	13	15
96	9120	9141	9162	9183	9204	9226	9247	9268	9290	9311	2	4	6	8	11	13	11	13	15
97	9333	9354	9376	9397	9419	9441	9462	9484	9506	9528	2	4	7	9	11	13	11	13	15
98	9550	9572	9594	9616	9638	9661	9683	9705	9727	9750	2	4	7	9	11	13	11	13	15
99	9772	9795	9817	9840	9863	9886	9908	9931	9954	9977	2	5	7	9	11	14	11	13	15





# INDEX.

(The numbers refer to pages.)

## A

Alternative fulcra for testing machines, 428  
Aluminium, 46  
Aluminium-bronze, 46  
Anchor ring, 341, 349  
Andrews, T., 59  
Annealing, 51  
Arched ribs, 356  
Arnold, Prof. J. O., experiments of reversals of stress, 76, 456  
Assumptions in theory of bending, 104  
Autographic recorders, 442

## B

Bairstow, L., 75  
Baker, Sir B., 73  
Bauschinger, 73, 81, 477, 479  
Beams, Chaps. IV., V., VI., VII., VIII.  
—, built-in, Chap. VIII.  
—, deflection of, Chap. VI. and 228, 234  
—, stresses in, Chap. V.  
—, of uniform strength, 131, 186  
—, resilience of, 226  
Beare, Prof. T. H., 474  
Bending, theory of, 86, 101, 107  
— beyond elastic limit, 144  
— combined with torsion, 283  
— tests, 428, 450, 478  
— of curved bars, 332  
— moments, 86  
— from funicular polygon, 94  
—, relation to shearing force, 95  
— unsymmetrical, 146, 244  
Benedicks, on hardness, 461  
Blue heat, hardening at, 51  
Brass, 44  
Brick, 475  
Brinell hardness test, 461, 463  
Bronzes, 45  
Buckton testing machine, 427

## C

Calibration of testing machines, 437  
Cantilever, 90  
— bridge, 224  
—, deflection of, 161, 172, 235  
Carriage spring, 188, 229  
Cast iron, 40  
— — beams, 124, 144  
Catenary, 374  
Cement, 467  
— testing machines, 469  
Centrifugal tension, 313  
Chain links, 351  
Chains, hanging, 370  
Chree, Dr. C., 315, 415, 423  
Christie, J., on struts, 274  
Clapeyron's theorem of three moments, 210, 214  
Clark, T. C., on struts, 274  
Coefficient of elasticity, 4; table, 61  
Coker, Dr. E. G., 287, 446, 453  
Combined bending and direct stress, 242  
— — — torsion, 283  
— stresses, 33 and footnote  
Commercial elastic limit, 31  
— tension tests, 434  
Component stresses, 4  
Compound cylinders, 307  
— stresses, 14  
Compression, 52, 428, 475  
Concrete, 474  
—, reinforced, 124  
—, steel, 124  
Continuous beams, 209  
—, advantages and disadvantages, 223  
— of varying section, 220  
Contraction of section, 10, 37  
Contrary flexure, points of, 94  
Copper, 44  
—, alloys of, 44  
Cores, 245  
Coupling-rod, stress in, 273  
Critical frequency, 82, 403

Crushing strength, table, 61  
 Curvature of beams, 103, 154  
 — —, transverse, 232  
 Cylinders, compound, 307  
 —, rotating, 320  
 —, thick, 303  
 —, thin, 299

D

Dangerous speeds, 403  
 Deflection of beams, Chap. VI.  
 — due to shearing beams, 234  
 — from bending-moment diagrams,  
 170, 180, 182  
 — of carriage spring, 188  
 — of flat plates, 385, 387, 390, 393,  
 395  
 — of helical spring, 289, 292  
 — of rotating shaft, 414  
 Diagrams of bending moment, 87  
 Disc, rotating, 315  
 — — of uniform strength, 330  
 — — of varying thickness, 328  
 Ductile metals, 29  
 Ductility, 29  
 —, importance of, 34  
 Dunkerley, Prof. S., 415  
 Dynamic effect of live load, 65, 66, 82,  
 230

## E

Eccentric loads, 242  
 — — on long columns, 259  
 Elastic constants, 7  
 — —, determination of, 451  
 — —, modified, 25  
 — —, relations between, 10  
 Elastic limits, 3, 30  
 — —, commercial, 31  
 — —, raising, 47  
 Elastic strain energy, 64, 233  
 — strength, theories of, 33  
 Elasticity, 1, 3, 29  
 —, modulus of, 4  
 —, theory of, 1  
 Ellipse of inertia, 122  
 — of stress, 17  
 Ellipsoid of strain, 25  
 Elongation, percentage, 34  
 Encasté beams, 193  
 End thrust with torsion, 285  
 Engineering Standards Committee, 37,  
 39, 44, 467, 469  
 Equation of three moments, 210, 214  
 Euler's theory of long pillars, 249, 253  
 Ewing, Prof. J. A., 32, 49, 82, 83, 440  
 Experiments on struts, 257  
 Extensometers, 439

## F

Factor of safety, 32, 83; table, 84  
 Fairbairn, 71  
 Fatigue, 70  
 Ferro-concrete, 124  
 Fidler, Prof. T. C., on struts, 274  
 Fixing-couples on beams, 196  
 Flexure, points of contrary, 94  
 Fluctuating stresses, 71 to 84  
 — —, explanation of failure under, 80  
 Flywheel rim, stress in, 313  
 Fractures, 54, 287  
 Funicular polygon, 94, 182

## G

Gardner, T., preface  
 Gerber's parabola, 77  
 Goodman, Prof. J., 43, 339, 439, 443,  
 and preface  
 Gordon's rule for struts, 255  
 Graphical determination of area moments,  
 117  
 — — of beam deflections, 172, 179,  
 181  
 — — of centroids, 117  
 — — of moments of inertia, 117  
 Graphical methods for beam deflections  
 due to shearing, 238  
 — — for built-in beams, 202, 208  
 — — for continuous beams, 213,  
 221  
 Greenhill, Prof., 419  
 Guest, J. J., 33  
 Guillery hardness tests, 463  
 Gyration, radius of, 111

## H

Hadfield, Sir R., 58 footnote  
 Hancock, Prof. E. L., 33 footnote, 287  
 footnote  
 Hanging wires and chains, 370  
 Hardening, 50, 51  
 Hardness tests, 457, 463, 464  
 Hatt, Prof. W. K., timber tests, 477  
 Helical seams in cylindrical shell, 302  
 — springs, 288  
 Hodgkinson, E., on struts, 274  
 Hollow shafts, 280  
 Hooke's law, 4  
 Hooks, stresses in, 339  
 Hopkinson, Prof. B., 52 footnote, 67  
 Humphrey, J. C. W., 83

## I

Impact of falling weight, 66  
 — producing flexure, 230

Impact tests, 495  
 — testing machines, 465  
 Inertia, moment of, 111  
 — —, graphical determination, 117  
 Infection, points of, 94  
 Intensity of stress, 1  
 — — —, actual and nominal, 30,  
 38

## J

Johnson, Prof. J. B., 58, 477, and  
 preface  
 — — —, formula for struts, 257  
 — — —, timber tests, 477  
 Joints riveted, 138, 301

## K

Kennedy, Sir Alex., 80 footnote  
 Keyways, effect of, on round shafts, 282

## L

Lame's theory of thick cylinders, 303  
 Lateral loads on struts and tie rods, 267  
 Launhardt, 77  
 Le Chatelier cement test, 472  
 Lily, Prof. W. E., on struts, 274  
 Limiting range of stress, 77  
 Link polygon, 94  
 Links, 351  
 Live loads, 65  
 Long columns, 249  
 — — — under eccentric loads, 259  
 Longitudinal vibrations, 404  
 Lüder's lines, 31

## M

Malleability, 29  
 Manganese-bronze, 45  
 Martens, Prof. A., hardness test, 464  
 Masonry seating for beam ends, 246  
 Mellor, Dr. J. W., 32 footnote  
 Metallography, 31  
 Microscopic observations, 31, 83  
 Modulus, bulk, 9, 453  
 — of elasticity, 4  
 — figures, 121  
 — of rigidity, 8, 451; table of, 61  
 — of section, 106, 114  
 — of rupture, 145, 479  
 —, Youngs, 7, 451; table of, 61  
 Moisture in timber, 476  
 Moment of inertia of sections, 105, 111  
 — of resistance, 87, 105  
 Momental ellipse, 122  
 Moncrieff, J. M., on struts, 274

Morrow, Dr. J., on beam strains, 145;  
 on extensometers, 439; on Poisson's  
 ratio, 453  
 Muir, Dr. J., 49 footnote, 50 footnote,  
 81 footnote

## N

Natural elastic limits, 81  
 — vibrations, 401  
 Neutral axis, 102, 103  
 — surface, 102  
 Nominal stress, 30, 38

## O

Oak, strength of, 478, 479, 480  
 Oblique stresses, 4  
 Oval cylinders, 301  
 — plate, 396  
 Overstrain, 47

## P

Pearson, Prof. Karl, 339 footnote, and  
 preface  
 Perry, Prof. J., 261, 269 footnote, 274  
 Phosphor-bronze, 45  
 Pillars, 248  
 Pipes, 299  
 Pitch of rivets in girders, 138  
 Plasticity, 29  
 Plates, flat, 378  
 Points of contrary flexure, 94  
 Poisson's ratio, 10, 453  
 Principal planes, 14  
 — strains, 24  
 — stresses, 14, 19; in beams, 140  
 Proof resilience, 65, 226  
 Propped beams, 159, 163, 169, 173

## R

Raising the elastic limit, 47  
 Rankine's formula for struts, 254  
 Rate of loading, 48, 52  
 Rectangular plate, 398  
 Reduction in area, 37  
 Reinforced concrete, 124  
 Relation between elastic constants, 10  
 — of curvature slope and deflection in  
 beams, 154, 170  
 Resilience, 64  
 — of beams, 226  
 —, shearing, 233  
 —, torsional, 287  
 Resistance to shocks, 68  
 Resolution of stresses, 14

Reversals of stress, 71-84, 454  
 ———, explanations of failure  
   under, 80  
 Reynolds, Prof. O., 74  
 Riehlé testing machine, 433  
 Rings, 341, 349  
 Rivets in boilers, 301  
   — girders, 138  
 Rogers, F., experiments on reversals of  
   stress, 76  
 Rosenhain, W., 32  
 Rotating cylinder, 320  
   — disc, 315  
   — of uniform strength, 330  
   — of varying thickness, 328  
   — ring or wheel rim, 313

## S

Safety, factor of, 32  
 Sankey, Capt. J. R., 423, 457  
   —, hand bending machine, 457  
 Scoble, W. A., 33 footnote  
 Second moment of areas, 111  
 Shafts, 280  
   — of non-circular section, 281  
 Shear strain, 3  
   — stress, 2  
   —, simple, 6  
   — in beams, 132, 142  
 Shearing deflection of beams, 234  
   — force, 86  
   —, relation to bending moment,  
   95  
   — resilience, 233  
   — strength table, 61, 480  
   — tests, 436, 479  
 Shells, 299  
 Shocks, resistance to, 68  
 Silicon-bronze, 45  
 Simple bending, 101  
   — shear, 6  
 Slip bands, 32  
 Smith, Prof. J. H., experiments on re-  
   versals of stress, 74, 454  
 Smith, Prof. R. H., 262  
 Spangenberg, 73  
 Spherical shell, thick, 306  
   — thin, 302  
 Spring, carriage, 188, 229  
   —, flat spiral, 354  
   —, helical, 288  
 Square plates, 398  
   — shafts, 281  
 Steel, 43  
 Steel sections, 115  
 Stiffness of beams, 153  
   — of springs, 289, 402  
 Stone, 474

Strain, 3  
   —, ellipsoid of, 25  
   — energy, 64  
   — principal, 24  
 Strength, elastic, 32  
   —, tables of, 61, 478  
   —, ultimate, 32  
 Stress, 1  
   — due to change of temperature, 58,  
   364, 368  
   — due to impact, 66  
   —, ellipse of, 17  
   — lines, 40  
   —, nominal and actual, 30, 38  
   —, oblique, 4  
   —, principal, 14, 19  
   —, shear, 2  
   —, simple, 2  
 Struts, 246  
   — laterally loaded, 267, 268

## T

Temperature, effect on properties, 57  
   — stresses, 59  
   — in arched ribs, 364, 368  
 Tenacity, 32, 40; table, 61, 478  
 Tension tests, 426, 434, 477  
   — of wire, 448  
 Test piece, 434  
   —, effect of shape of, 39  
 Testing machines, 426  
   —, calibration of, 437  
   — for hardness, 461  
 Theorem of three moments, 209, 214  
 Theory of bending, 86, 101, 107  
 Thick cylinder, 303  
   — spherical shell, 306  
 Thin cylinders, 297  
   — spherical shell, 302  
 Thrust on columns, Chap. IX.  
   — on rotating shaft, 417  
   — with torsion, 285, 417  
 Tie rods laterally loaded, 267, 271  
 Timber, 476  
 Time, effect of, 48, 52, 480  
 Tin, 52  
 Tomlinson, G. A., 49 footnote, and  
   preface  
 Torsion, 277  
   — and bending, 283  
   — beyond elastic limit, 286  
   — of non-circular shafts, 281  
   — of wires, 449  
 Torsional resilience, 287  
   — strain, 446  
   — vibrations, 419  
 Transverse curvature of beams, 232  
   — vibrations, 406, 410, 412

## U

- Ultimate strength, 32  
 ——— tables of, 61, 478, 479  
 Unit stress, 1  
 Unsymmetrical bending, 146, 244  
 Unwin, Prof. W. C., 35, 460

## V

- Vibrations, 401  
 ———, free or natural, 401  
 ———, forced, 403  
 ———, longitudinal, 404  
 ———, transverse, 406, 410, 416  
 ———, torsional, 419

## W

- Weston, A. T., 301  
 Weyraugh, 77

- Whirling speed of shafts, 412  
 Wicksteed's autographic recorders, 442,  
 443  
 ——— testing machine, 426, 429  
 Wilson's method for continuous beams,  
 214  
 Wire ropes, 480  
 Wires, hanging, 370  
 ———, tension of, 448  
 ———, torsion of, 449  
 Wöhler's experiments, 71, 454  
 Work done in straining, 63  
 Working stress, 32  
 Wrought iron, 42

## Y

- Yield point, 30  
 ———, determination of, 451  
 ———, raising, 47  
 Young's modulus, 7

THE END



**Architecture, Building Construction, Strength of Materials, etc.—cont.**

- STRENGTH OF MATERIALS.** By ARTHUR MORLEY, M.Sc., M.I.Mech.E. With 248 Diagrams and numerous Examples. 8vo, 7s. 6d. net.
- THEORY OF STRUCTURES.** By ARTHUR MORLEY, M.Sc., M.I.Mech.E. With 320 Diagrams and numerous Examples. 8vo, 7s. 6d. net.
- LIGHT RAILWAY CONSTRUCTION.** By RICHARD MARION PARKINSON, Assoc.M.Inst.C.E. With 85 Diagrams. Medium 8vo, 10s. 6d. net.
- DOMESTIC SANITARY ENGINEERING AND PLUMBING,** dealing with Domestic Water Supplies, Pump and Hydraulic Ram Work, Hydraulics, Sanitary Work, Heating by Low Pressure, Hot Water, and External Plumbing Work. By F. W. RAYNES. With 277 Illustrations. 8vo, 10s. 6d. net.
- HEATING SYSTEMS: DESIGN OF HOT WATER AND STEAM HEATING APPARATUS.** By F. W. RAYNES. With Illustrations. 8vo, 10s. 6d. net.
- GRAPHICS, or The Art of Calculation by Drawing Lines,** applied especially to Mechanical Engineering. By ROBERT H. SMITH, Emeritus Professor of Engineering. With separate Atlas of 29 Plates containing 97 Diagrams. 8vo, 15s.
- THE THEORY OF STRESSES IN GIRDERS AND SIMILAR STRUCTURES,** with Practical Observations on the Strength and other Properties of Materials. By BINDON B. STONEY, LL.D., F.R.S., M.I.C.E. With 5 Plates and 143 Illustrations in the Text. Royal 8vo, 36s.
- THE TESTING OF MATERIALS OF CONSTRUCTION.** A Text-Book for the Engineering Laboratory and a Collection of the Results of Experiment. By W. CAWTHORNE UNWIN, F.R.S., LL.D. With 5 Plates and 206 Diagrams. 8vo, 18s. net.
- CIVIL ENGINEERING AS APPLIED IN CONSTRUCTION.** By LEVESON FRANCIS VERNON-HARCOURT, M.A., M.Inst.C.E. Revised by HENRY FIDLER, M.Inst.C.E., F.G.S. With 368 Illustrations. Medium 8vo, 16s. net.
- SANITARY ENGINEERING WITH RESPECT TO WATER-SUPPLY AND SEWAGE DISPOSAL.** By LEVESON FRANCIS VERNON-HARCOURT, M.A., M.Inst.C.E. With 287 Illustrations. Medium 8vo, 14s. net.

**Architecture, Building Construction, Strength of Materials, etc.—cont.**

**ENGINEERING CONSTRUCTION IN IRON, STEEL, AND TIMBER.** By WILLIAM HENRY WARREN. With 12 Folding Plates and 443 Diagrams. Medium 8vo, 18s. net.

**REINFORCED CONCRETE CONSTRUCTION IN THEORY AND PRACTICE:** an Elementary Manual for Students and others. By HENRY ADAMS, M.Inst.C.E., M.I.Mech.E., F.S.I., F.R.San.I., etc.; and ERNEST R. MATTHEWS, Assoc.M.Inst.C.E., F.R.S. (Ed.), F.R.San.I., F.G.S., Borough Engineer and Surveyor of Bridlington. With numerous Illustrations. 8vo, 10s. 6d.

**THE STRENGTH OF MATERIALS AND STRUCTURES:** the Strength of Materials as depending on their Quality and as ascertained by Testing Apparatus. By Sir J. ANDERSON, C.E., LL.D., F.R.S.E. With 66 Illustrations. Crown 8vo, 3s. 6d.

**CALCULATIONS IN HYDRAULIC ENGINEERING:** a Practical Text-Book for Students, Draughtsmen and Engineers. By T. CLAXTON FIDLER, M.Inst.C.E.

Part I. Fluid Pressure and the Calculation of its Effects in Engineering Structures. With numerous Illustrations and Examples. 8vo, 6s. 6d. net.

Part II. Calculations in Hydro-Kinetics. With numerous Illustrations and Examples. 8vo, 7s. 6d. net.

**NOTES ON CONSTRUCTION IN MILD STEEL,** arranged for the Use of Junior Draughtsmen in the Architectural and Engineering Professions, with Illustrations from Working Drawings, Diagrams, and Tables. By HENRY FIDLER, M.I.C.E. With Diagrams. 8vo, 16s. net.

**MECHANICS APPLIED TO ENGINEERING.** By JOHN GOODMAN, Wh.Sch., M.I.C.E., M.I.M.E., Professor of Engineering in the Leeds University. With 714 Illustrations and numerous Examples. Crown 8vo, 9s. net.

**MODERN SANITARY ENGINEERING AND PLUMBERS' WORK, PROGRESSIVE SCALE DRAWINGS OF CURRENT PRACTICE.** By A. HERRING-SHAW, A.R.San.I., M.Sc.Tech., Lecturer in the Department of Municipal and Sanitary Engineering, Municipal School of Technology, Manchester, and Assistant Lecturer in the Manchester University; and H. F. V. NEWSOME, A.M.S.A., Assistant Lecturer in the Department of Municipal and Sanitary Engineering, School of Technology, Manchester. Oblong folio (13½ in. × 10 in.). Vol. I., 2s. net. Vol. II., 2s. 6d. net.



Longitudal - Lengthwise  
Transverse - Across -

THIS BOOK IS DUE ON THE LAST DATE  
STAMPED BELOW

AN INITIAL FINE OF 25 CENTS  
WILL BE ASSESSED FOR FAILURE TO RETURN  
THIS BOOK ON THE DATE DUE. THE PENALTY  
WILL INCREASE TO 50 CENTS ON THE FOURTH  
DAY AND TO \$1.00 ON THE SEVENTH DAY  
OVERDUE.

SEP 16 1932

NOV 26 1932  
FEB 9 1934

OCT 29 1934

MAR 5 1935

FEB 13 1937

FEB 22 1937

OCT 14 1937

DEC 22 1939

APR 16 1942 E

JUN 15 1945

TA405

M7

1913

321787

Morley.

UNIVERSITY OF CALIFORNIA LIBRARY

