

STRENGTH OF MATERIALS
MAURER

UC-NRLF

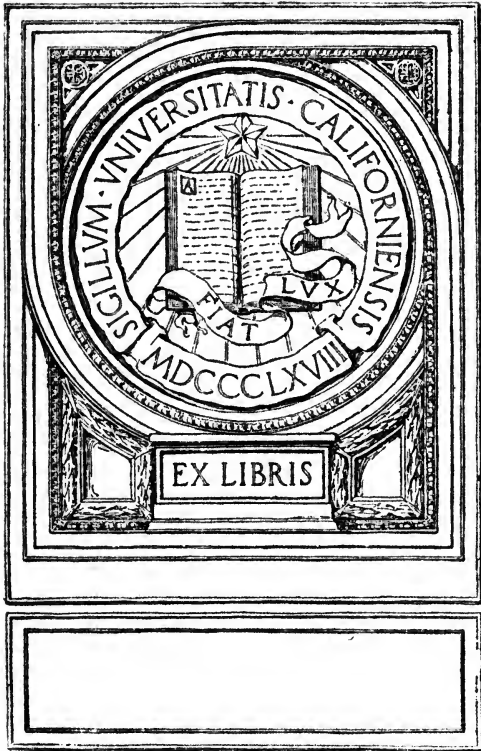

48 26 889



EX LIBRIS







STRENGTH OF MATERIALS

A COMPREHENSIVE PRESENTATION OF SCIENTIFIC METHODS
OF LOCATING AND DETERMINING STRESSES AND
CALCULATING THE REQUIRED STRENGTH
AND DIMENSIONS OF BUILDING
MATERIALS

BY

EDWARD R. MAURER, B. C. E.

PROFESSOR OF MECHANICS, UNIVERSITY OF WISCONSIN

ILLUSTRATED

UNIV. OF
CALIFORNIA

AMERICAN TECHNICAL SOCIETY
CHICAGO

1917

TA-05
M4

COPYRIGHT, 1907, 1914, 1917, BY
AMERICAN TECHNICAL SOCIETY

COPYRIGHTED IN GREAT BRITAIN
ALL RIGHTS RESERVED

70 1917
ANNOUNCED

INTRODUCTION

EVERY layman is fascinated by a great engineering work—a large sewage system, a Keokuk dam, a twenty-story steel structure—and wishes he might be able to construct such work and carry it to completion. And yet he hardly appreciates the knowledge, experience, and judgment necessary to bring such a work to a satisfactory close. Time was when all of the details of such structures were determined by guesswork, but the developments in science and mathematics have changed all that. Formulas for the various types of stresses have been worked out; constants for every known material have been collected; and a multitude of diagrams and tables contribute to making the engineer's work as precise as a bookkeeper's balance. The strength and size of every rivet and the length and cross-section of every girder in a steel structure are figured so they will bear the strains put upon them. The design of a masonry dam, the strength of the concrete mixture, and the amount of steel reinforcement are all mathematically determined in order to safely restrain the given volume of water behind it.

¶ The final judgment, therefore, as to the size of every part of the structure—must depend upon the designer's knowledge of "Strength of Materials." The treatment of Strength of Materials, as found in standard textbooks, is so clothed in abstruse mathematics that it is impossible for the average trained man to obtain a working knowledge of the subject. As the subject is one of the most important in any of the engineering branches, the author has thought it wise to present it in simple form, culling out all material that can not be used in practical design and analyzing the subject from the theory through to the practical formulas without the use of higher mathematics. In fact, he has used only such mathematics as may be easily understood. While the author has designed this work especially for home study purposes, the material is valuable to the college trained man as well, as it gives in clear, concise form the principles which are most used in engineering and architectural work. It is the hope of the publishers that the book will fill a place among the useful reference works in the field of engineering.

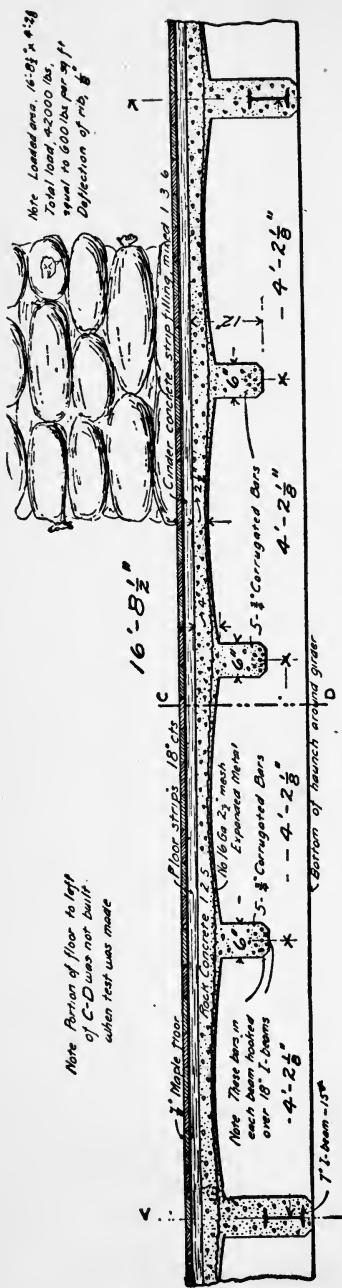

Note Loaded area, 16'-8 1/2" x 4'-3 1/2"
 Total load, 42000 lbs.
 equal to 600 lbs per sq ft
 Deflection of ribs, 1/8"

TRANSVERSE SECTION A-B



DETAIL OF CORRUGATED BAR

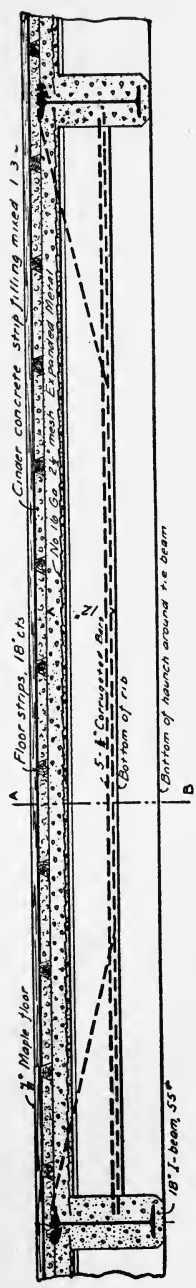

LONGITUDINAL SECTION C-D

CONTENTS

	PAGE
Simple stress	1
Kinds of stress.....	2
Tension, compression, shear.....	2
Unit-stress.....	3
Deformation.....	4
Elasticity.....	4
Hooke's law, and elastic limit.....	5
Ultimate strength.....	6
Stress-deformation diagram.....	6
Working stress and strength.....	8
Factor of safety.....	8
Strength of materials in tension.....	11
Strength of materials in compression.....	13
Strength of materials in shear.....	15
 Reaction of supports	 16
Moment of a force.....	16
Principle of moments.....	17
Kinds of beams.....	19
Determination of reactions on beams.....	19
 External shear and bending moment	 23
External shear.....	23
Rule of signs.....	23
Units for shears.....	24
Shear diagrams.....	27
Maximum shear.....	31
Bending moment.....	32
Moment diagrams.....	36
Maximum bending moment.....	40
Table of maximum shears, moments, etc.....	41
 Center of gravity and moment of inertia	 41
Center of gravity of an area.....	41
Principle of moments applied to areas.....	42
Center of gravity of built-up sections.....	44
Moment of inertia.....	46
Table of centers of gravity and moments of inertia.....	52
 Strength of beams	 52
Kinds of loads.....	52
Transverse, longitudinal, inclined forces.....	52
Neutral surface.....	54
Neutral line.....	54
Neutral axis.....	54
Stress at cross-section.....	55
Fibre stress.....	57

CONTENTS

	PAGE
Strength of beams (Continued)	
Value of the resisting moment	58
First beam formula	59
Applications of the first beam formula	59
Laws of strength of beams	71
Modulus of rupture	72
Resisting shear	73
Second beam formula	73
Horizontal shear	75
Design of timber beams	76
Kinds of loads and beams	79
Flexure and tension	79
Flexure and compression	81
Combined flexural and direct stress	83
Strength of columns	85
End conditions	85
Classes of columns	86
Cross sections of columns	86
Radius of gyration	86
Kinds of column loads	88
Rankine's column formula	88
Graphical representation of column formulas	93
Combination column formulas	94
Straight-line and Euler formulas	94
Parabola-Euler formulas	98
Broken straight-line formula	101
Design of columns	102
Strength of shafts	105
Twisting moment	105
Torsional stress	106
Resisting moment	107
Formula for the strength of a shaft	107
Formula for the power which a shaft can transmit	109
Stiffness of rods, beams, and shafts	110
Coefficient of elasticity	111
Temperature stresses	113
Deflection of beams	114
Twist of shafts	116
Non-elastic deformation	117
Riveted joints	118
Kinds of joints	118
Shearing strength, or shearing value, of a rivet	118
Bearing strength, or bearing value, of a plate	119
Frictional strength of a joint	119
Tensile and compressive strength of riveted plates	120
Computation of the strength of a joint	120
Efficiency of a joint	122

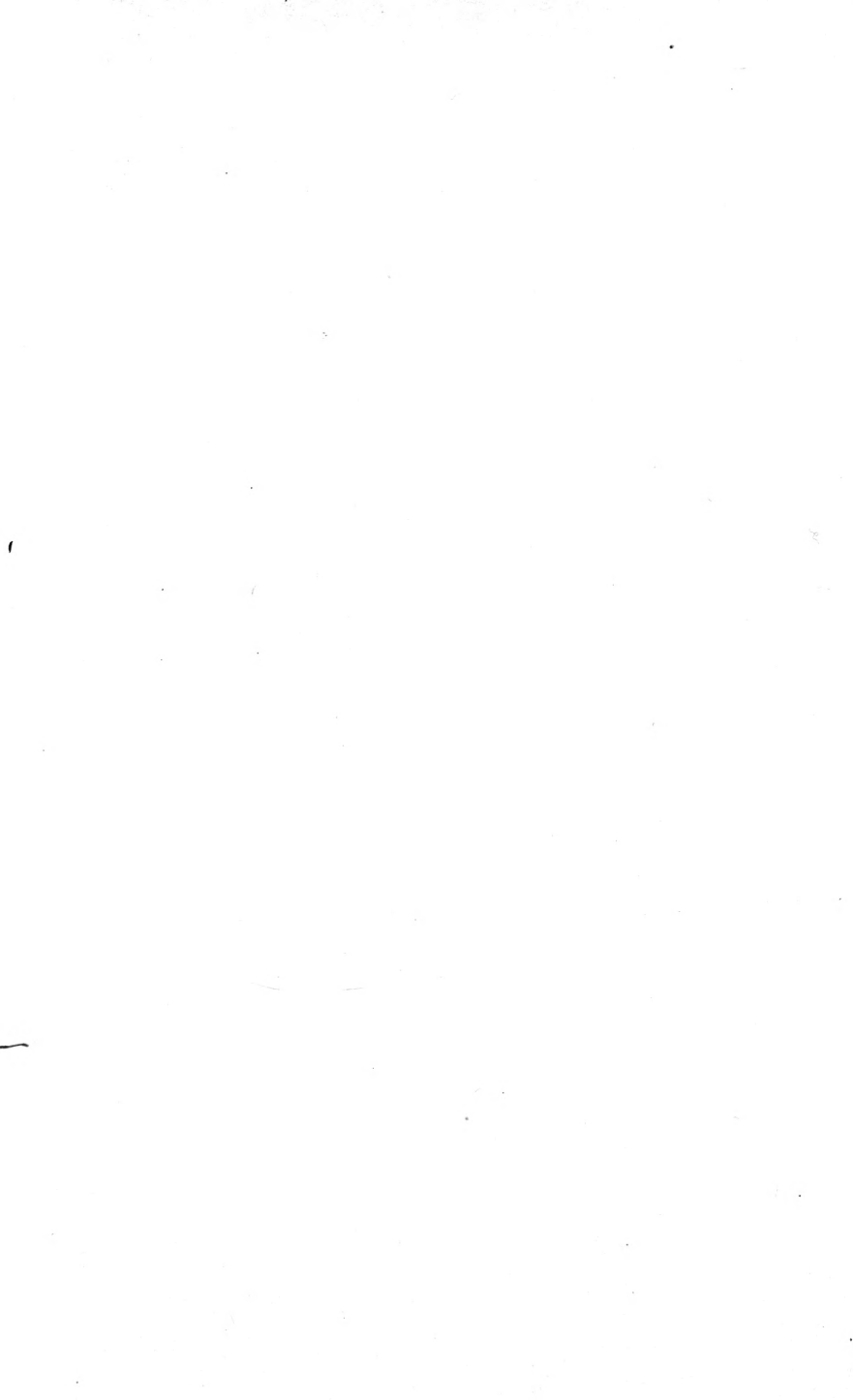

Danish Fir



Danish Fir



Danish Fir



Baltic Red



Pitch Pine



Pitch Pine



Swedish DDD



St Petersburg



Swedish



St Petersburg



English Oak



English Oak

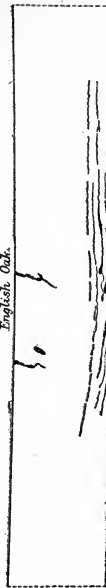

STRENGTH OF MATERIALS.

PART I.

SIMPLE STRESS.

1. **Stress.** When forces are applied to a body they tend in a greater or less degree to break it. Preventing or tending to prevent the rupture, there arise, generally, forces between every two adjacent parts of the body. Thus, when a load is suspended by means of an iron rod, the rod is subjected to a downward pull at its lower end and to an upward pull at its upper end, and these two forces tend to pull it apart. At any cross-section of the rod the iron on either side "holds fast" to that on the other, and these forces which the parts of the rod exert upon each other prevent the tearing of the rod. For example, in Fig. 1, let a represent the rod and its suspended load, 1,000 pounds; then the pull on the lower end equals 1,000 pounds. If we neglect the weight of the rod, the pull on the upper end is also 1,000 pounds, as shown in Fig. 1 (b); and the upper part A exerts on the lower part B an upward pull Q equal to 1,000 pounds, while the lower part exerts on the upper a force P also equal to 1,000 pounds. These two forces, P and Q , prevent rupture of the rod at the "section" C ; at any other section there are two forces like P and Q preventing rupture at that section.

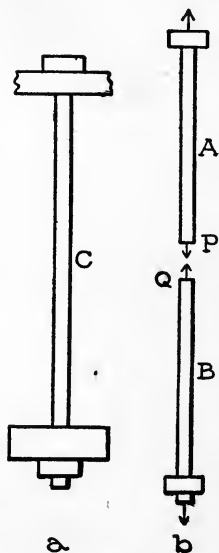

Fig. 1.

By *stress at a section* of a body is meant the force which the part of the body on either side of the section exerts on the other. Thus, the stress at the section C (Fig. 1) is P (or Q), and it equals 1,000 pounds.

2. Stresses are usually expressed (in America) in pounds, sometimes in tons. Thus the stress P in the preceding article is

1,000 pounds, or $\frac{1}{2}$ ton. Notice that this value has nothing to do with the size of the cross-section on which the stress acts.

3. Kinds of Stress. (a) When the forces acting on a body (as a rope or rod) are such that they tend to tear it, the stress at any cross-section is called a *tension* or a *tensile stress*. The stresses P and Q, of Fig. 1, are tensile stresses. Stretched ropes, loaded "tie rods" of roofs and bridges, etc., are under tensile stress.

(b.) When the forces acting on a body (as a short post, brick, etc.) are such that they tend to crush it, the stress at any section at right angles to the direction of the crushing forces is called a *pressure* or a *compressive stress*.

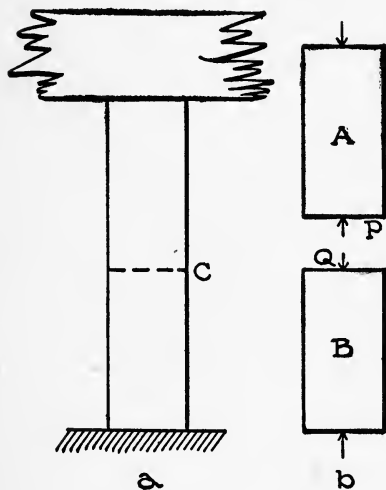

Fig. 2.

Fig. 2 (a) represents a loaded post, and Fig. 2 (b) the upper and lower parts. The upper part presses down on B, and the lower part presses up on A, as shown. P or Q is the compressive stress in the post at section C. Loaded posts, or struts, piers, etc., are under compressive stress.

(c.) When the forces acting on a body (as a rivet in a bridge

joint) are such that they tend to cut or "shear" it across, the stress at a section along which there is a tendency to cut is called a *shear* or a *shearing stress*. This kind of stress takes its name from the act of cutting with a pair of shears. In a material which is being cut in this way, the stresses that are being "overcome" are shearing stresses. Fig. 3 (a) represents a riveted joint, and Fig. 3 (b) two parts of the rivet. The forces applied to the joint are such that A tends to slide to the left, and B to the right; then B exerts on A a force P toward the right, and A on B a force Q toward the left as shown. P or Q is the shearing stress in the rivet.

Tensions, Compressions and Shears are called *simple stresses*. Forces may act upon a body so as to produce a combination of simple stresses on some section; such a combination is called a *complex*

stress. The stresses in beams are usually complex. There are other terms used to describe stress; they will be defined farther on.

4. **Unit-Stress.** It is often necessary to specify not merely the amount of the entire stress which acts on an area, but also the amount which acts on each unit of area (square inch for example). By unit-stress is meant stress per unit area.

To find the value of a unit-stress: *Divide the whole stress by the whole area of the section on which it acts, or over which it is distributed.* Thus, let

P denote the value of the whole stress,

A the area on which it acts, and

S the value of the unit-stress; then

$$S = \frac{P}{A}, \text{ also } P = AS. \quad (1)$$

Strictly these formulas apply only when the stress P is uniform,

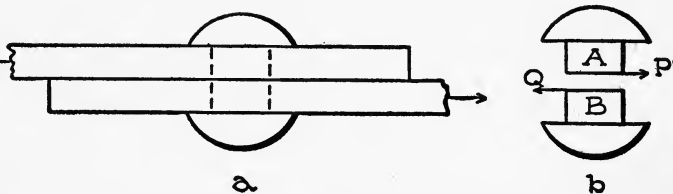

Fig. 3.

that is, when it is uniformly distributed over the area, each square inch for example sustaining the same amount of stress. When the stress is not uniform, that is, when the stresses on different square inches are not equal, then $P \div A$ equals the *average value* of the unit-stress.

5. Unit-stresses are usually expressed (in America) in pounds per square inch, sometimes in tons per square inch. If P and A in equation 1 are expressed in pounds and square inches respectively, then S will be in pounds per square inch; and if P and A are expressed in tons and square inches, S will be in tons per square inch.

Examples. 1. Suppose that the rod sustaining the load in Fig. 1 is 2 square inches in cross-section, and that the load weighs 1,000 pounds. What is the value of the unit-stress?

Here $P = 1,000$ pounds, $A = 2$ square inches; hence.

$$S = \frac{1,000}{2} = 500 \text{ pounds per square inch.}$$

2. Suppose that the rod is one-half square inch in cross-section. What is the value of the unit-stress?

$A = \frac{1}{2}$ square inch, and, as before, $P = 1,000$ pounds; hence

$$S = 1,000 \div \frac{1}{2} = 2,000 \text{ pounds per square inch.}$$

Notice that one must always divide the whole stress by the area to get the unit-stress, whether the area is greater or less than one.

6. Deformation. Whenever forces are applied to a body it changes in size, and usually in shape also. This change of size and shape is called deformation. Deformations are usually measured in inches; thus, if a rod is stretched 2 inches, the "elongation" = 2 inches.

7. Unit-Deformation. It is sometimes necessary to specify not merely the value of a total deformation but its amount per unit length of the deformed body. Deformation per unit length of the deformed body is called unit-deformation.

To find the value of a unit-deformation: *Divide the whole deformation by the length over which it is distributed.* Thus, if

D denotes the value of a deformation,

l the length,

s the unit-deformation, then

$$s = \frac{D}{l}, \text{ also } D = ls. \quad (2)$$

Both D and l should always be expressed in the same unit.

Example. Suppose that a 4-foot rod is elongated $\frac{1}{2}$ inch. What is the value of the unit-deformation?

Here $D = \frac{1}{2}$ inch, and $l = 4$ feet = 48 inches;

hence $s = \frac{1}{2} \div 48 = \frac{1}{96}$ inch per inch.

That is, each inch is elongated $\frac{1}{96}$ inch.

Unit-elongations are sometimes expressed in per cent. To express an elongation in per cent: *Divide the elongation in inches by the original length in inches, and multiply by 100.*

8. Elasticity. Most solid bodies when deformed will regain more or less completely their natural size and shape when the de-

forming forces cease to act. This property of regaining size and shape is called elasticity.

We may classify bodies into kinds depending on the degree of elasticity which they have, thus:

1. *Perfectly elastic* bodies; these will regain their original form and size no matter how large the applied forces are if less than breaking values. Strictly there are no such materials, but rubber, practically, is perfectly elastic.

2. *Imperfectly elastic* bodies; these will fully regain their original form and size if the applied forces are not too large, and practically even if the loads are large but less than the breaking value. Most of the constructive materials belong to this class.

3. *Inelastic* or *plastic* bodies; these will not regain in the least their original form when the applied forces cease to act. Clay and putty are good examples of this class.

9. **Hooke's Law, and Elastic Limit.** If a gradually increasing force is applied to a perfectly elastic material, the deformation increases proportionally to the force; that is, if P and P' denote two values of the force (or stress), and D and D' the values of the deformation produced by the force,

$$\text{then } P:P':: D:D'.$$

This relation is also true for imperfectly elastic materials, provided that the loads P and P' do not exceed a certain limit depending on the material. Beyond this limit, the deformation increases much faster than the load; that is, if within the limit an addition of 1,000 pounds to the load produces a stretch of 0.01 inch, beyond the limit an equal addition produces a stretch larger and usually much larger than 0.01 inch.

Beyond this limit of proportionality a part of the deformation is permanent; that is, if the load is removed the body only partially recovers its form and size. The permanent part of a deformation is called *set*.

The fact that for most materials the deformation is proportional to the load within certain limits, is known as Hooke's Law. The unit-stress within which Hooke's law holds, or above which the deformation is not proportional to the load or stress, is called *elastic limit*.

10. Ultimate Strength. By ultimate tensile, compressive, or shearing strength of a material is meant the greatest tensile, compressive, or shearing unit-stress which it can withstand.

As before mentioned, when a material is subjected to an increasing load the deformation increases faster than the load beyond the elastic limit, and much faster near the stage of rupture. Not only do tension bars and compression blocks elongate and shorten respectively, but their cross-sectional areas change also; tension bars thin down and compression blocks "swell out" more or less. The value of the ultimate strength for any material is ascertained by subjecting a specimen to a gradually increasing tensile, compressive, or shearing stress, as the case may be, until rupture occurs, and measuring the greatest load. *The breaking load divided by the area of the original cross-section sustaining the stress, is the value of the ultimate strength.*

Example. Suppose that in a tension test of a wrought-iron rod $\frac{1}{2}$ inch in diameter the greatest load was 12,540 pounds. What is the value of the ultimate strength of that grade of wrought iron?

The original area of the cross-section of the rod was

$0.7854 \text{ (diameter)}^2 = 0.7854 \times \frac{1}{4} = 0.1964$ square inches; hence the ultimate strength equals

$12,540 \div 0.1964 = 63,850$ pounds per square inch. (nearly).

11. Stress-Deformation Diagram. A "test" to determine the elastic limit, ultimate strength, and other information in regard to a material is conducted by applying a gradually increasing load until the specimen is broken, and noting the deformation corresponding to many values of the load. The first and second columns of the following table are a record of a tension test on a steel rod one inch in diameter. The numbers in the first column are the values of the pull, or the loads, at which the elongation of the specimen was measured. The elongations are given in the second column. The numbers in the third and fourth columns are the values of the unit-stress and unit-elongation corresponding to the values of the load opposite to them. The numbers in the third column were obtained from those in the first by dividing the latter by the area of the cross-section of the rod, 0.7854 square inches. Thus,

$$3,930 \div 0.7854 = 5,000$$

$$7,850 \div 0.7854 = 10,000, \text{ etc.}$$

Total Pull in pounds, P	Deformation in inches, D	Unit-Stress in pounds per square inch, S	Unit- Deformation, s
3930	0.00136	5000	0.00017
7850	.00280	10000	.00035
11780	.00404	15000	.00050
15710	.00538	20000	.00067
19635	.00672	25000	.00084
23560	.00805	30000	.00101
27490	.00942	35000	.00118
31415	.01080	40000	.00135
35345	.01221	45000	.00153
39270	.0144	50000	.00180
43200	.0800	55000	.0100
47125	.1622	60000	.0202
51050	.201	65000	.0251
54980	.281	70000	.0351
58910	.384	75000	.048
62832	.560	80000	.070
65200	1.600	83000	.200

The numbers in the fourth column were obtained by dividing those in the second by the length of the specimen (or rather the length of that part whose elongation was measured), 8 inches. Thus,

$$0.00136 \div 8 = 0.00017,$$

$$.00280 \div 8 = .00035, \text{ etc.}$$

Looking at the first two columns it will be seen that the elongations are practically proportional to the loads up to the ninth load, the increase of stretch for each increase in load being about 0.00135 inch; but beyond the ninth load the increases of stretch are much greater. Hence the elastic limit was reached at about the ninth load, and its value is about 45,000 pounds per square inch. The greatest load was 65,200 pounds, and the corresponding unit-stress, 83,000 pounds per square inch, is the ultimate strength.

Nearly all the information revealed by such a test can be well represented in a diagram called a *stress-deformation diagram*. It is made as follows: Lay off the values of the unit-deformation (fourth column) along a horizontal line, according to some convenient scale, from some fixed point in the line. At the points on the horizontal line representing the various unit-elongations, lay off perpendicular distances equal to the corresponding unit-stresses. Then connect by a smooth curve the upper ends of all those distances, last distances laid off. Thus, for instance, the highest unit-

elongation (0.20) laid off from o (Fig. 4) fixes the point a , and a perpendicular distance to represent the highest unit-stress (83,000) fixes the point b . All the points so laid off give the curve ocb . The part oc , within the elastic limit, is straight and nearly vertical while the remainder is curved and more or less horizontal, especially toward the point of rupture b . Fig. 5 is a typical stress-deformation diagram for timber, cast iron, wrought iron, soft and hard steel, in tension and compression.

12. Working Stress and Strength, and Factor of Safety.

The greatest unit-stress in any part of a structure when it is sustaining its loads is called the *working stress* of that part. If it is under tension, compression and shearing stresses, then the corresponding highest unit-stresses in it are called its working stress in tension, in compression, and in shear respectively; that is, we speak of as many working stresses as it has kinds of stress.

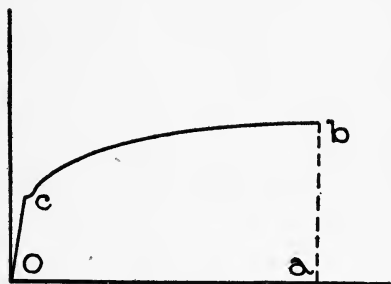

Fig. 4.

By *working strength* of a material to be used for a certain purpose is meant the highest unit-stress to which the material ought to be subjected when so used. Each material has a working strength for tension, for compression, and for shear, and they are in general different.

By *factor of safety* is meant the ratio of the ultimate strength of a material to its working stress or strength. Thus, if

S_u denotes ultimate strength,
 S_w denotes working stress or strength, and
 f denotes factor of safety, then

$$f = \frac{S_u}{S_w}; \text{ also } S_w = \frac{S_u}{f}. \quad (3)$$

When a structure which has to stand certain loads is about to be designed, it is necessary to select working strengths or factors of safety for the materials to be used. Often the selection is a matter of great importance, and can be wisely performed only by an experienced engineer, for this is a matter where hard-and-

fast rules should not govern but rather the judgment of the expert. But there are certain principles to be used as guides in making a selection, chief among which are:

1. The working strength should be considerably below the elastic limit. (Then the deformations will be small and not permanent.)

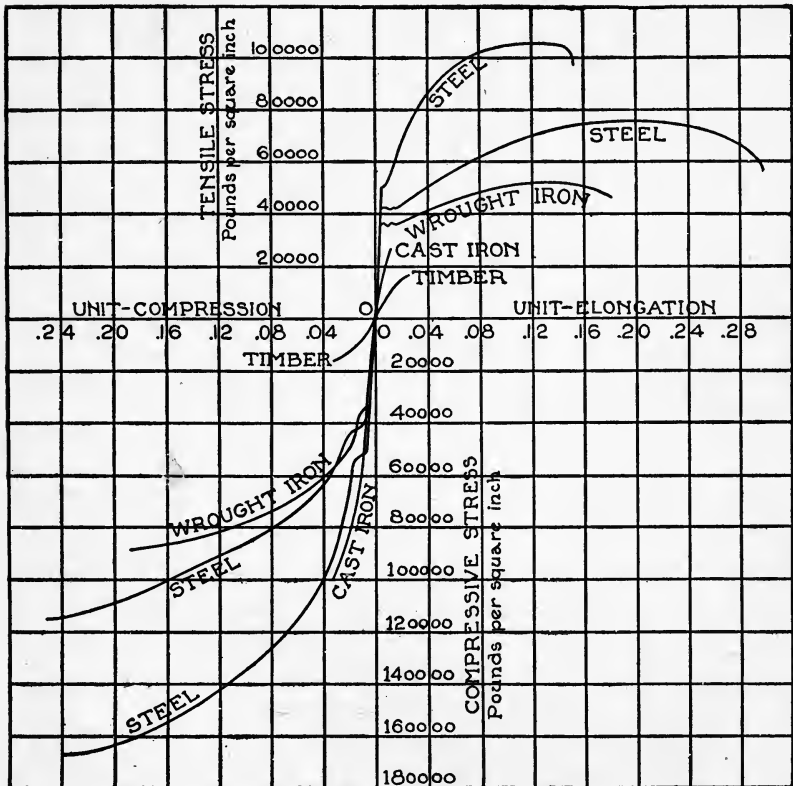

Fig. 5. (After Johnson.)

2. The working strength should be smaller for parts of a structure sustaining varying loads than for those whose loads are steady. (Actual experiments have disclosed the fact that the strength of a specimen depends on the kind of load put upon it, and that in a general way it is less the less steady the load is.)

3. The working strength must be taken low for non-uniform material, where poor workmanship may be expected, when the

loads are uncertain, etc. Principles 1 and 2 have been reduced to figures or formulas for many particular cases, but the third must remain a subject for display of judgment, and even good guessing in many cases.

The following is a table of factors of safety* which will be used in the problems:

Factors of Safety.

Materials.	For steady stress. (Buildings.)	For varying stress. (Bridges.)	For shocks. (Machines.)
Timber	8	10	15
Brick and stone	15	25	30
Cast iron	6	15	20
Wrought iron	4	6	10
Steel	5	7	15

They must be regarded as average values and are not to be adopted in every case in practice.

Examples. 1. A wrought-iron rod 1 inch in diameter sustains a load of 30,000 pounds. What is its working stress? If its ultimate strength is 50,000 pounds per square inch, what is its factor of safety?

The area of the cross-section of the rod equals $0.7854 \times (\text{diameter})^2 = 0.7854 \times 1^2 = 0.7854$ square inches. Since the whole stress on the cross-section is 30,000 pounds, equation 1 gives for the unit working stress

$$S = \frac{30,000}{0.7854} = 38,197 \text{ pounds per square inch.}$$

Equation 3 gives for factor of safety

$$f = \frac{50,000}{38,197} = 1.3$$

2. How large a steel bar or rod is needed to sustain a steady pull of 100,000 pounds if the ultimate strength of the material is 65,000 pounds?

The load being steady, we use a factor of safety of 5 (see table above); hence the working strength to be used (see equation 3) is

$$S = \frac{65,000}{5} = 13,000 \text{ pounds per square inch.}$$

The proper area of the cross-section of the rod can now be computed from equation 1 thus:

*Taken from Merriman's "Mechanics of Materials."

$$A = \frac{P}{S} = \frac{100,000}{13,000} = 7.692 \text{ square inches.}$$

A bar 2×4 inches in cross-section would be a little stronger than necessary. To find the diameter (d) of a round rod of sufficient strength, we write $0.7854 d^2 = 7.692$, and solve the equation for d ; thus:

$$d^2 = \frac{7.692}{0.7854} = 9.794, \text{ or } d = 3.129 \text{ inches.}$$

3. How large a steady load can a short timber post safely sustain if it is 10×10 inches in cross-section and its ultimate compressive strength is 10,000 pounds per square inch?

According to the table (page 12) the proper factor of safety is 8, and hence the working strength according to equation 3 is

$$S = \frac{10,000}{8} = 1,250 \text{ pounds per square inch.}$$

The area of the cross-section is 100 square inches; hence the safe load (see equation 1) is

$$P = 100 \times 1,250 = 125,000 \text{ pounds.}$$

4. When a hole is punched through a plate the shearing strength of the material has to be overcome. If the ultimate shearing strength is 50,000 pounds per square inch, the thickness of the plate $\frac{1}{2}$ inch, and the diameter of the hole $\frac{3}{4}$ inch, what is the value of the force to be overcome?

The area shorn is that of the cylindrical surface of the hole or the metal punched out; that is

$$3.1416 \times \text{diameter} \times \text{thickness} = 3.1416 \times \frac{3}{4} \times \frac{1}{2} = 1.178 \text{ sq. in.}$$

Hence, by equation 1, the total shearing strength or resistance to punching is

$$P = 1.178 \times 50,000 = 58,900 \text{ pounds.}$$

STRENGTH OF MATERIALS UNDER SIMPLE STRESS.

13. Materials in Tension. Practically the only materials used extensively under tension are timber, wrought iron and steel, and to some extent cast iron.

14. Timber. A successful tension test of wood is difficult, as the specimen usually crushes at the ends when held in the testing machine, splits, or fails otherwise than as desired. Hence the

tensile strengths of woods are not well known, but the following may be taken as approximate average values of the ultimate strengths of the woods named, when "dry out of doors."

Hemlock,	7,000 pounds per square inch.		
White pine,	8,000	"	"
Yellow pine, long leaf,	12,000	"	"
" " , short leaf,	10,000	"	"
Douglas spruce,	10,000	"	"
White oak,	12,000	"	"
Red oak,	9,000	"	"

15. Wrought Iron. The process of the manufacture of wrought iron gives it a "grain," and its tensile strengths along and across the grain are unequal, the latter being about three-fourths of the former. The ultimate tensile strength of wrought iron along the grain varies from 45,000 to 55,000 pounds per square inch. Strength along the grain is meant when not otherwise stated.

The strength depends on the size of the piece, it being greater for small than for large rods or bars, and also for thin than for thick plates. The elastic limit varies from 25,000 to 40,000 pounds per square inch, depending on the size of the bar or plate even more than the ultimate strength. Wrought iron is very ductile, a specimen tested in tension to destruction elongating from 5 to 25 per cent of its length.

16. Steel. Steel has more or less of a grain but is practically of the same strength in all directions. To suit different purposes, steel is made of various grades, chief among which may be mentioned rivet steel, sheet steel (for boilers), medium steel (for bridges and buildings), rail steel, tool and spring steel. In general, these grades of steel are hard and strong in the order named, the ultimate tensile strength ranging from about 50,000 to 160,000 pounds per square inch.

There are several grades of structural steel, which may be described as follows:*

1. Rivet steel:

Ultimate tensile strength, 48,000 to 58,000 pounds per square inch.

Elastic limit, not less than one-half the ultimate strength.

Elongation, 26 per cent.

Bends 180 degrees flat on itself without fracture.

*Taken from "Manufacturer's Standard Specifications."

2. **Soft steel:**

Ultimate tensile strength, 52,000 to 62,000 pounds per square inch.

Elastic limit, not less than one-half the ultimate strength.

Elongation, 25 per cent.

Bends 180 degrees flat on itself.

3. **Medium steel:**

Ultimate tensile strength, 60,000 to 70,000 pounds per square inch.

Elastic limit, not less than one-half the ultimate strength.

Elongation, 22 per cent.

Bends 180 degrees to a diameter equal to the thickness of the specimen without fracture.

17. Cast Iron. As in the case of steel, there are many grades of cast iron. The grades are not the same for all localities or districts, but they are based on the appearance of the fractures, which vary from coarse dark grey to fine silvery white.

The ultimate tensile strength does not vary uniformly with the grades but depends for the most part on the percentage of "combined carbon" present in the iron. This strength varies from 15,000 to 35,000 pounds per square inch, 20,000 being a fair average.

Cast iron has no well-defined elastic limit (see curve for cast iron, Fig. 5). Its ultimate elongation is about one per cent.

EXAMPLES FOR PRACTICE.

1. A steel wire is one-eighth inch in diameter, and the ultimate tensile strength of the material is 150,000 pounds per square inch. How large is its breaking load? Ans. 1,845 pounds.

2. A wrought-iron rod (ultimate tensile strength 50,000 pounds per square inch) is 2 inches in diameter. How large a steady pull can it safely bear? Ans. 39,270 pounds.

18. Materials in Compression. Unlike the tensile, the compressive strength of a specimen or structural part depends on its dimension in the direction in which the load is applied, for, in compression, a long bar or rod is weaker than a short one. At present we refer only to the strength of short pieces such as do not bend under the load, the longer ones (columns) being discussed farther on.

Different materials break or fail under compression, in two very different ways:

1. Ductile materials (structural steel, wrought iron, etc.),

and wood compressed across the grain, do not fail by breaking into two distinct parts as in tension, but the former bulge out and flatten under great loads, while wood splits and mashes down. There is no particular point or instant of failure under increasing loads, and such materials have no definite ultimate strength in compression.

2. Brittle materials (brick, stone, hard steel, cast iron, etc.), and wood compressed along the grain, do not mash gradually, but fail suddenly and have a definite ultimate strength in compression. Although the surfaces of fracture are always much inclined to the direction in which the load is applied (about 45 degrees), the ultimate strength is computed by dividing the total breaking load by the cross-sectional area of the specimen.

The principal materials used under compression in structural work are timber, wrought iron, steel, cast iron, brick and stone.

19. Timber. As before noted, timber has no definite ultimate compressive strength across the grain. The U. S. Forestry Division has adopted certain amounts of compressive *deformation* as marking stages of failure. Three per cent compression is regarded as "a working limit allowable," and fifteen per cent as "an extreme limit, or as failure." The following (except the first) are values for compressive strength from the Forestry Division Reports, all in pounds per square inch:

	Ultimate strength along the grain.	3% Compression across the grain
Hemlock	6,000	
White pine.....	5,400	700
Long-leaf yellow pine.....	8,000	1,260
Short-leaf yellow pine.....	6,500	1,050
Douglas spruce.....	5,700	800
White oak.....	8,500	2,200
Red oak.....	7,200	2,300

20. Wrought Iron. The elastic limit of wrought iron, as before noted, depends very much upon the size of the bars or plate, it being greater for small bars and thin plates. Its value for compression is practically the same as for tension, 25,000 to 40,000 pounds per square inch.

21. Steel. The hard steels have the highest compressive strength; there is a recorded value of nearly 400,000 pounds per square inch; but 150,000 is probably a fair average.

The elastic limit in compression is practically the same as in tension, which is about 60 per cent of the ultimate tensile strength, or, for structural steel, about 25,000 to 42,000 pounds per square inch.

22. Cast Iron. This is a very strong material in compression, in which way, principally, it is used structurally. Its ultimate strength depends much on the proportion of "combined carbon" and silicon present, and varies from 50,000 to 200,000 pounds per square inch, 90,000 being a fair average. As in tension, there is no well-defined elastic limit in compression (see curve for cast iron, Fig. 5).

23. Brick. The ultimate strengths are as various as the kinds and makes of brick. For soft brick, the ultimate strength is as low as 500 pounds per square inch, and for pressed brick it varies from 4,000 to 20,000 pounds per square inch, 8,000 to 10,000 being a fair average. The ultimate strength of good paving brick is still higher, its average value being from 12,000 to 15,000 pounds per square inch.

24. Stone. Sandstone, limestone and granite are the principal building stones. Their ultimate strengths in pounds per square inch are about as follows:

Sandstone,* 5,000 to 16,000, average 8,000.

Limestone,* 8,000 " 16,000, " 10,000.

Granite, 14,000 " 24,000, " 16,000.

*Compression at right angles to the "bed" of the stone.

EXAMPLES FOR PRACTICE.

1. A limestone 12×12 inches on its bed is used as a pier cap, and bears a load of 120,000 pounds. What is its factor of safety? Ans. 12.

2. How large a post (short) is needed to sustain a steady load of 100,000 pounds if the ultimate compressive strength of the wood is 10,000 pounds per square inch? Ans. 8×10 inches.

25. Materials in Shear. The principal materials used under shearing stress are timber, wrought iron, steel and cast iron. Partly on account of the difficulty of determining shearing strengths, these are not well known.

26. Timber. The ultimate shearing strengths of the more important woods *along the grain* are about as follows:

Hemlock,	300	pounds per square inch.
White pine,	400	“ “
Long-leaf yellow pine,	850	“ “
Short-leaf “ “	775	“ “
Douglas spruce,	500	“ “
White oak,	1,000	“ “
Red oak,	1,100	“ “

Wood rarely fails by shearing across the grain. Its ultimate

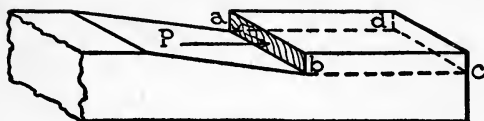

Fig. 6 a.

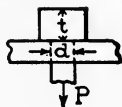

Fig. 6 b.

shearing strength in that direction is probably four or five times the values above given.

27. Metals. The ultimate shearing strength of wrought iron, steel, and cast iron is about 80 per cent of their respective ultimate tensile strengths.

EXAMPLES FOR PRACTICE.

1. How large a pressure P (Fig. 6 a) exerted on the shaded area can the timber stand before it will shear off on the surface $abcd$, if $ab = 6$ inches and $bc = 10$ inches, and the ultimate shearing strength of the timber is 400 pounds per square inch?

Ans. 24,000 pounds.

2. When a bolt is under tension, there is a tendency to tear the bolt and to “strip” or shear off the head. The shorn area would be the surface of the cylindrical hole left in the head. Compute the tensile and shearing unit-stresses when P (Fig. 6 b) equals 30,000 pounds, $d = 2$ inches, and $t = 3$ inches.

Ans. $\left\{ \begin{array}{l} \text{Tensile unit-stress, 9,550 pounds per square inch.} \\ \text{Shearing unit-stress, 1,591 pounds per square inch.} \end{array} \right.$

REACTIONS OF SUPPORTS.

28. Moment of a Force. By moment of a force with respect to a point is meant its tendency to produce rotation about that point. Evidently the tendency depends on the magnitude of the force and on the perpendicular distance of the line of action of the force from the point: the greater the force and the perpendicular distance, the greater the tendency; hence *the moment*

of a force with respect to a point equals the product of the force and the perpendicular distance from the force to the point.

The point with respect to which the moment of one or more forces is taken is called an *origin* or *center of moments*, and the perpendicular distance from an origin of moments to the line of action of a force is called the *arm* of the force with respect to that origin. Thus, if F_1 and F_2 (Fig. 7) are forces, their arms with respect to O' are a_1' and a_2' respectively, and their moments are $F_1 a_1'$ and $F_2 a_2'$. With respect to O'' their arms are a_1'' and a_2'' respectively, and their moments are $F_1 a_1''$ and $F_2 a_2''$.

If the force is expressed in pounds and its arm in feet, the moment is in foot-pounds; if the force is in pounds and the arm in inches, the moment is in inch-pounds.

29. A *sign* is given to the moment of a force for convenience; the rule used herein is as follows: *The moment of a force about a point is positive or negative according as it tends to turn the body about that point in the clockwise or counter-clockwise direction**.

Thus the moment (Fig. 7)

of F_1 about O' is negative, about O'' positive;

“ F_2 “ O' “ “ , about O'' negative.

30. **Principle of Moments.** In general, a single force of proper magnitude and line of action can balance any number of forces. That single force is called the *equilibrant* of the forces, and the single force that would balance the equilibrant is called the *resultant* of the forces. Or, otherwise stated, the resultant of any number of forces is a force which produces the same effect. It can be proved that—*The algebraic sum of the moments of any number of forces with respect to a point, equals the moment of their resultant about that point.*

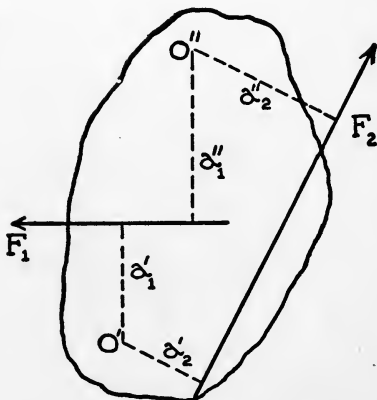

Fig. 7.

*By clockwise direction is meant that in which the hands of a clock rotate; and by counter-clockwise. the opposite direction.

This is a useful principle and is called "principle of moments."

31. All the forces acting upon a body which is at rest are said to be *balanced* or *in equilibrium*. No force is required to balance such forces and hence their equilibrant and resultant are zero.

Since their resultant is zero, *the algebraic sum of the mom-*

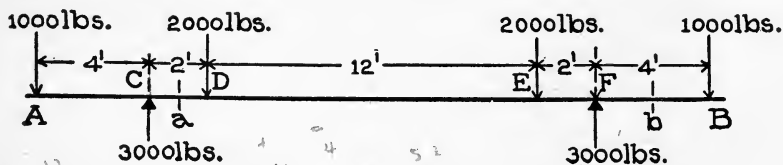

Fig. 8.

ents of any number of forces which are balanced or in equilibrium equals zero.

This is known as the principle of moments for forces in equilibrium; for brevity we shall call it also "the principle of moments."

The principle is easily verified in a simple case. Thus, let AB (Fig. 8) be a beam resting on supports at C and F. It is evident from the symmetry of the loading that each reaction equals one-half of the whole load, that is, $\frac{1}{2}$ of 6,000 = 3,000 pounds. (We neglect the weight of the beam for simplicity.)

With respect to C, for example, the moments of the forces are, taking them in order from the left:

$$\begin{aligned}
 -1,000 \times 4 &= -4,000 \text{ foot-pounds} \\
 3,000 \times 0 &= 0 \text{ " } \\
 2,000 \times 2 &= 4,000 \text{ " } \\
 2,000 \times 14 &= 28,000 \text{ " } \\
 -3,000 \times 16 &= -48,000 \text{ " } \\
 1,000 \times 20 &= 20,000 \text{ " }
 \end{aligned}$$

The algebraic sum of these moments is seen to equal zero.

Again, with respect to B the moments are:

$$\begin{aligned}
 -1,000 \times 24 &= -24,000 \text{ foot-pounds} \\
 3,000 \times 20 &= 60,000 \text{ " } \\
 -2,000 \times 18 &= -36,000 \text{ " } \\
 -2,000 \times 6 &= -12,000 \text{ " } \\
 3,000 \times 4 &= 12,000 \text{ " } \\
 1,000 \times 0 &= 0 \text{ " }
 \end{aligned}$$

The sum of these moments also equals zero. In fact, no matter

where the center of moments is taken, it will be found in this and any other balanced system of forces that the algebraic sum of their moments equals zero. The chief use that we shall make of this principle is in finding the supporting forces of loaded beams.

32. Kinds of Beams. A *cantilever beam* is one resting on one support or fixed at one end, as in a wall, the other end being free.

A *simple beam* is one resting on two supports.

A *restrained beam* is one fixed at both ends; a beam fixed at one end and resting on a support at the other is said to be restrained at the fixed end and simply supported at the other.

A *continuous beam* is one resting on more than two supports.

33. Determination of Reactions on Beams. The forces which the supports exert on a beam, that is, the "supporting forces," are called *reactions*. We shall deal chiefly with simple beams. The reaction on a cantilever beam supported at one point evidently equals the total load on the beam.

When the loads on a horizontal beam are all vertical (and

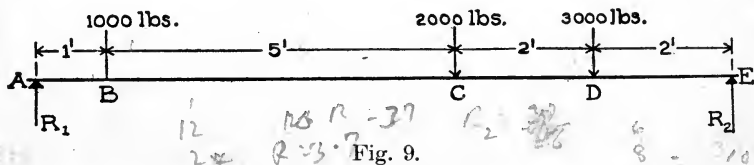

this is the usual case), the supporting forces are also vertical and the sum of the reactions equals the sum of the loads. This principle is sometimes useful in determining reactions, but in the case of simple beams the principle of moments is sufficient. The general method of determining reactions is as follows:

1. Write out two equations of moments for all the forces (loads and reactions) acting on the beam with origins of moments at the supports.

2. Solve the equations for the reactions.

3. As a check, try if the sum of the reactions equals the sum of the loads.

Examples. 1. Fig. 9 represents a beam supported at its ends and sustaining three loads. We wish to find the reactions due to these loads.

Let the reactions be denoted by R_1 and R_2 as shown; then the moment equations are:

For origin at A,

$$1,000 \times 1 + 2,000 \times 6 + 3,000 \times 8 - R_2 \times 10 = 0.$$

For origin at E,

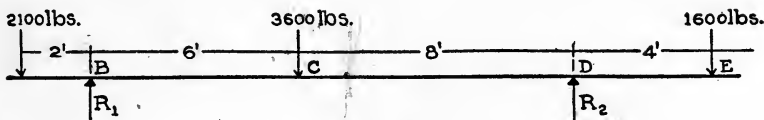

Fig. 10.

$$R_1 \times 10 - 1,000 \times 9 - 2,000 \times 4 - 3,000 \times 2 = 0.$$

The first equation reduces to

$$10 R_2 = 1,000 + 12,000 + 24,000 = 37,000; \text{ or}$$

$$R_2 = 3,700 \text{ pounds.}$$

The second equation reduces to

$$10 R_1 = 9,000 + 8,000 + 6,000 = 23,000; \text{ or}$$

$$R_1 = 2,300 \text{ pounds.}$$

The sum of the loads is 6,000 pounds and the sum of the reactions is the same; hence the computation is correct.

2. Fig. 10 represents a beam supported at B and D (that is, it has overhanging ends) and sustaining three loads as shown. We wish to determine the reactions due to the loads.

Let R_1 and R_2 denote the reactions as shown; then the moment equations are:

For origin at B,

$$-2,100 \times 2 + 0 + 3,600 \times 6 - R_2 \times 14 + 1,600 \times 18 = 0.$$

For origin at D,

$$-2,100 \times 16 + R_1 \times 14 - 3,600 \times 8 + 0 + 1,600 \times 4 = 0.$$

The first equation reduces to

$$14 R_2 = -4,200 + 21,600 + 28,800 = 46,200; \text{ or}$$

$$R_2 = 3,300 \text{ pounds.}$$

The second equation reduces to

$$14 R_1 = 33,600 + 28,800 - 6,400 = 56,000; \text{ or}$$

$$R_1 = 4,000 \text{ pounds.}$$

The sum of the loads equals 7,300 pounds and the sum of the reactions is the same; hence the computation checks.

3. What are the total reactions in example 1 if the beam weighs 400 pounds?

(1.) Since we already know the reactions due to the loads (2,300 and 3,700 pounds at the left and right ends respectively (see illustration 1 above), we need only to compute the reactions due to the weight of the beam and add. Evidently the reactions due to the weight equal 200 pounds each; hence the

$$\begin{aligned} \text{left reaction} &= 2,300 + 200 = 2,500 \text{ pounds, and the} \\ \text{right " } &= 3,700 + 200 = 3,900 \text{ " } \end{aligned}$$

(2.) Or, we might compute the reactions due to the loads and weight of the beam together and directly. In figuring the moment due to the weight of the beam, we imagine the weight as concentrated at the middle of the beam; then its moments with respect to the left and right supports are (400×5) and $-(400 \times 5)$ respectively. The moment equations for origins at A and E are like those of illustration 1 except that they contain one more term, the moment due to the weight; thus they are respectively:

$$1,000 \times 1 + 2,000 \times 6 + 3,000 \times 8 - R_2 \times 10 + 400 \times 5 = 0,$$

$$R_1 \times 10 - 1,000 \times 9 - 2,000 \times 4 - 3,000 \times 2 - 400 \times 5 = 0.$$

The first one reduces to

$$10 R_2 = 39,000, \text{ or } R_2 = 3,900 \text{ pounds;}$$

and the second to

$$10 R_1 = 25,000, \text{ or } R_1 = 2,500 \text{ pounds.}$$

4. What are the total reactions in example 2 if the beam weighs 42 pounds per foot?

As in example 3, we might compute the reactions due to the weight and then add them to the corresponding reactions due to the loads (already found in example 2), but we shall determine the total reactions due to load and weight directly.

The beam being 20 feet long, its weight is 42×20 , or 840 pounds. Since the middle of the beam is 8 feet from the left and 6 feet from the right support, the moments of the weight with to the left and right supports are respectively:

$$840 \times 8 = 6,720, \text{ and } -840 \times 6 = -5,040 \text{ foot-pounds.}$$

The moment equations for all the forces applied to the beam for origins at B and D are like those in example 2, with an additional term, the moment of the weight; they are respectively:

$$-2,100 \times 2 + 0 + 3,600 \times 6 - R_2 \times 14 + 1,600 \times 18 + 6,720 = 0,$$

$$-2,100 \times 16 + R_1 \times 14 - 3,600 \times 8 + 0 + 1,600 \times 4 - 5,040 = 0.$$

The first equation reduces to

$$14 R_2 = 52,920, \text{ or } R_2 = 3,780 \text{ pounds,}$$

and the second to

$$14 R_1 = 61,040, \text{ or } R_1 = 4,360 \text{ pounds.}$$

The sum of the loads and weight of beam is 8,140 pounds, and since the sum of the reactions is the same, the computation checks.

EXAMPLES FOR PRACTICE.

1. AB (Fig. 11) represents a simple beam supported at its ends. Compute the reactions, neglecting the weight of the beam.

$$\text{Ans. } \begin{cases} \text{Right reaction} = 1,443.75 \text{ pounds.} \\ \text{Left reaction} = 1,556.25 \text{ pounds.} \end{cases}$$

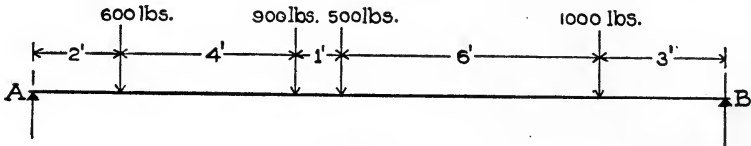

Fig. 11.

2. Solve example 1 taking into account the weight of the beam, which suppose to be 400 pounds.

$$\text{Ans. } \begin{cases} \text{Right reaction} = 1,643.75 \text{ pounds.} \\ \text{Left reaction} = 1,756.25 \text{ pounds.} \end{cases}$$

3. Fig. 12 represents a simple beam weighing 800 pounds supported at A and B, and sustaining three loads as shown. What are the reactions ?

$$\text{Ans. } \begin{cases} \text{Right reaction} = 2,014.28 \text{ pounds.} \\ \text{Left reaction} = 4,785.72 \text{ pounds.} \end{cases}$$

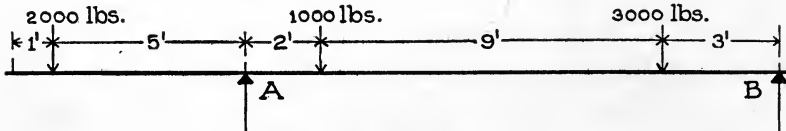

Fig. 12.

4. Suppose that in example 3 the beam also sustains a uniformly distributed load (as a floor) over its entire length, of 500 pounds per foot. Compute the reactions due to all the loads and the weight of the beam.

$$\text{Ans. } \begin{cases} \text{Right reaction} = 4,871.43 \text{ pounds.} \\ \text{Left reaction} = 11,928.57 \text{ pounds.} \end{cases}$$

EXTERNAL SHEAR AND BENDING MOMENT.

On almost every cross-section of a loaded beam there are three kinds of stress, namely tension, compression and shear. The first two are often called *fibre stresses* because they act along the real fibres of a wooden beam or the imaginary ones of which we may suppose iron and steel beams composed. Before taking up the subject of these stresses in beams it is desirable to study certain quantities relating to the loads, and on which the stresses in a beam depend. These quantities are called *external shear* and *bending moment*, and will now be discussed.

34. External Shear. By external shear at (or for) any section of a loaded beam is meant the algebraic sum of all the loads (including weight of beam) and reactions on *either side* of the section. This sum is called external shear because, as is shown later, it equals the shearing stress (internal) at the section. For brevity, we shall often say simply "shear" when external shear is meant.

35. Rule of Signs. In computing external shears, it is customary to give the plus sign to the reactions and the minus sign to the loads. But in order to get the same sign for the external shear whether computed from the right or left, we *change the sign* of the sum when computed from the loads and reactions *to the right*. Thus for section *a* of the beam in Fig. 8 the algebraic sum is, when computed from the left,

$$-1,000 + 3,000 = +2,000 \text{ pounds;}$$

and when computed from the right,

$$-1,000 + 3,000 - 2,000 - 2,000 = -2,000 \text{ pounds.}$$

The external shear at section *a* is +2,000 pounds.

Again, for section *b* the algebraic sum is, when computed from the left,

$$-1,000 + 3,000 - 2,000 - 2,000 + 3,000 = +1,000 \text{ pounds;}$$

and when computed from the right, -1,000 pounds.

The external shear at the section is +1,000 pounds.

It is usually convenient to compute the shear at a section from the forces to the right or left according as there are fewer forces (loads and reactions) on the right or left sides of the section.

36. Units for Shears. It is customary to express external shears in pounds, but any other unit for expressing force and weight (as the ton) may be used.

37. Notation. We shall use V to stand for external shear at any section, and the shear at a particular section will be denoted by that letter subscripted; thus V_1, V_2 , etc., stand for the shears at sections one, two, etc., feet from the left end of a beam.

The shear has different values just to the left and right of a support or concentrated load. We shall denote such values by V' and V'' ; thus V_5' and V_5'' denote the values of the shear at sections a little less and a little more than 5 feet from the left end respectively.

Examples. 1. Compute the shears for sections one foot apart in the beam represented in Fig. 9, neglecting the weight of the beam. (The right and left reactions are 3,700 and 2,300 pounds respectively; see example 1, Art. 33.)

All the following values of the shear are computed from the left. The shear just to the right of the left support is denoted by V_0'' , and $V_0'' = 2,300$ pounds. The shear just to the left of B is denoted by V_1' , and since the only force to the left of the section is the left reaction, $V_1' = 2,300$ pounds. The shear just to the right of B is denoted by V_1'' , and since the only forces to the left of this section are the left reaction and the 1,000-pound load, $V_1'' = 2,300 - 1,000 = 1,300$ pounds. To the left of all sections between B and C, there are but two forces, the left reaction and the 1,000-pound load; hence the shear at any of those sections equals $2,300 - 1,000 = 1,300$ pounds, or

$$V_2 = V_3 = V_4 = V_5 = V_6' = 1,300 \text{ pounds.}$$

The shear just to the right of C is denoted by V_6'' ; and since the forces to the left of that section are the left reaction and the 1,000- and 2,000-pound loads,

$$V_6'' = 2,300 - 1,000 - 2,000 = -700 \text{ pounds.}$$

Without further explanation, the student should understand that

$$V_7 = +2,300 - 1,000 - 2,000 = -700 \text{ pounds,}$$

$$V_8' = -700,$$

$$V_8'' = +2,300 - 1,000 - 2,000 - 3,000 = -3,700,$$

$$V_9 = V_{10}' = -3,700,$$

$$V_{10}'' = +2,300 - 1,000 - 2,000 - 3,000 + 3,700 = 0$$

2. A simple beam 10 feet long, and supported at each end, weighs 400 pounds, and bears a uniformly distributed load of 1,600 pounds. Compute the shears for sections two feet apart.

Evidently each reaction equals one-half the sum of the load and weight of the beam, that is, $\frac{1}{2} (1,600 + 400) = 1,000$ pounds. To the left of a section 2 feet from the left end, the forces acting on the beam consist of the left reaction, the load on that part of the beam, and the weight of that part; then since the load and weight of the beam *per foot* equal 200 pounds,

$$V_2 = 1,000 - 200 \times 2 = 600 \text{ pounds.}$$

To the left of a section four feet from the left end, the forces are the left reaction, the load on that part of the beam, and the weight; hence

$$V_4 = 1,000 - 200 \times 4 = 200 \text{ pounds.}$$

Without further explanation, the student should see that

$$V_6 = 1,000 - 200 \times 6 = -200 \text{ pounds,}$$

$$V_8 = 1,000 - 200 \times 8 = -600 \text{ pounds,}$$

$$V_{10}' = 1,000 - 200 \times 10 = -1,000 \text{ pounds,}$$

$$V_{10}'' = 1,000 - 200 \times 10 + 1,000 = 0.$$

3. Compute the values of the shear in example 1, taking into account the weight of the beam (400 pounds). (The right and left reactions are then 3,900 and 2,500 pounds respectively; see example 3, Art. 33.)

We proceed just as in example 1, except that in each computation we include the weight of the beam to the left of the section (or to the right when computing from forces to the right). The weight of the beam being 40 pounds per foot, then (computing from the left)

$$V_0'' = +2,500 \text{ pounds,}$$

$$V_1' = +2,500 - 40 = +2,460,$$

$$V_1'' = +2,500 - 40 - 1,000 = +1,460,$$

$$V_2 = +2,500 - 1,000 - 40 \times 2 = +1,420,$$

$$V_3 = +2,500 - 1,000 - 40 \times 3 = +1,380,$$

$$V_4 = +2,500 - 1,000 - 40 \times 4 = +1,340,$$

$$V_5 = +2,500 - 1,000 - 40 \times 5 = +1,300,$$

$$V_6' = +2,500 - 1,000 - 40 \times 6 = +1,260,$$

$$V_6'' = +2,500 - 1,000 - 40 \times 6 - 2,000 = -740,$$

$$V_7 = +2,500 - 1,000 - 2,000 - 40 \times 7 = -780,$$

$$\begin{aligned}
 V_8' &= +2,500 - 1,000 - 2,000 - 40 \times 8 = -820, \\
 V_8'' &= +2,500 - 1,000 - 2,000 - 40 \times 8 - 3,000 = -3,820, \\
 V_9 &= +2,500 - 1,000 - 2,000 - 3,000 - 40 \times 9 = -3,860, \\
 V_{10}' &= +2,500 - 1,000 - 2,000 - 3,000 - 40 \times 10 = -3,900, \\
 V_{10}'' &= +2,500 - 1,000 - 2,000 - 3,000 - 40 \times 10 + 3,900 = 0.
 \end{aligned}$$

Computing from the right, we find, as before, that

$$\begin{aligned}
 V_7 &= -(3,900 - 3,000 - 40 \times 3) = -780 \text{ pounds,} \\
 V_8' &= -(3,900 - 3,000 - 40 \times 2) = -820, \\
 V_8'' &= -(3,900 - 40 \times 2) = -3,820, \\
 &\text{etc., etc.}
 \end{aligned}$$

EXAMPLES FOR PRACTICE.

1. Compute the values of the shear for sections of the beam represented in Fig. 10, neglecting the weight of the beam. (The right and left reactions are 3,300 and 4,000 pounds respectively; see example 2, Art. 33.)

$$\text{Ans.} \left\{ \begin{aligned}
 V_1 &= V_2' = -2,100 \text{ pounds,} \\
 V_2'' &= V_3 = V_4 = V_5 = V_6 = V_7 = V_8' = +1,900, \\
 V_8'' &= V_9 = V_{10} = V_{11} = V_{12} = V_{13} = V_{14} = V_{15} = V_{16}' = -1,700, \\
 V_{16}'' &= V_{17} = V_{18} = V_{19} = V_{20}' = +1,600.
 \end{aligned} \right.$$

2. Solve the preceding example, taking into account the weight of the beam, 42 pounds per foot. (The right and left reactions are 3,780 and 4,360 pounds respectively; see example 4, Art. 33.)

$$\text{Ans.} \left\{ \begin{array}{lll}
 V_0'' = -2,100 \text{ lbs.} & V_7 = +1,966 \text{ lbs.} & V_{14} = -1,928 \text{ lbs.} \\
 V_1 = -2,142 & V_8' = +1,924 & V_{15} = -1,970 \\
 V_2' = -2,184 & V_8'' = -1,676 & V_{16}' = -2,012 \\
 V_2'' = +2,176 & V_9 = -1,718 & V_{16}'' = +1,768 \\
 V_3 = +2,134 & V_{10} = -1,760 & V_{17} = +1,726 \\
 V_4 = +2,092 & V_{11} = -1,802 & V_{18} = +1,684 \\
 V_5 = +2,050 & V_{12} = -1,844 & V_{19} = +1,642 \\
 V_6 = +2,008 & V_{13} = -1,886 & V_{20}' = +1,600
 \end{array} \right.$$

3. Compute the values of the shear at sections one foot apart in the beam of Fig. 11, neglecting the weight. (The right and left reactions are 1,444 and 1,556 pounds respectively; see example 1, Art. 33.)

$$\text{Ans.} \left\{ \begin{array}{l} V_0'' = V_1 = V_2' = +1,556 \text{ pounds,} \\ V_2'' = V_3 = V_4 = V_5 = V_6' = +956, \\ V_6'' = V_7' = +56, \\ V_7'' = V_8 = V_9 = V_{10} = V_{11} = V_{12} = V_{13}' = -444, \\ V_{13}'' = V_{14} = V_{15} = V_{16}' = -1,444. \end{array} \right.$$

4. Compute the vertical shear at sections one foot apart in the beam of Fig. 12, taking into account the weight of the beam, 800 pounds, and a distributed load of 500 pounds per foot. (The right and left reactions are 4,870 and 11,930 pounds respectively; see examples 3 and 4, Art. 33.)

$$\text{Ans.} \left\{ \begin{array}{lll} V_0 = 0 & V_7 = +6,150 \text{ lbs.} & V_{15} = + 830 \text{ lbs.} \\ V_1' = - 540 \text{ lbs.} & V_8' = +5,610 & V_{16} = + 290 \\ V_1'' = - 2,540 & V_8'' = +4,610 & V_{17}' = - 250 \\ V_2 = - 3,080 & V_9 = +4,070 & V_{17}'' = - 3,250 \\ V_3 = - 3,620 & V_{10} = +3,530 & V_{18} = - 3,790 \\ V_4 = - 4,160 & V_{11} = +2,990 & V_{19} = - 4,330 \\ V_5 = - 4,700 & V_{12} = +2,450 & V_{20}' = - 4,870 \\ V_6' = - 5,240 & V_{13} = +1,910 & V_{20}'' = 0 \\ V_6'' = +6,690 & V_{14} = +1,370 & \end{array} \right.$$

38. Shear Diagrams. The way in which the external shear varies from section to section in a beam can be well represented by means of a diagram called a *shear diagram*. To construct such a diagram for any loaded beam,

1. Lay off a line equal (by some scale) to the length of the beam, and mark the positions of the supports and the loads. (This is called a "base-line.")

2. Draw a line such that the distance of any point of it from the base equals (by some scale) the shear at the corresponding section of the beam, and so that the line is above the base where the shear is positive, and below it where negative. (This is called a *shear line*, and the distance from a point of it to the base is called the "ordinate" from the base to the shear line at that point.)

We shall explain these diagrams further by means of illustrative examples.

Examples. 1. It is required to construct the shear diagram for the beam represented in Fig. 13, *a* (a copy of Fig. 9).

Lay off $A'E'$ (Fig. 13, *b*) to represent the beam, and mark the positions of the loads B' , C' and D' . In example 1, Art. 37, we computed the values of the shear at sections one foot apart; hence we lay off ordinates at points on $A'E'$ one foot apart, to represent those shears.

Use a scale of 4,000 pounds to one inch. Since the shear for any section in AB is 2,300 pounds, we draw a line ab parallel to the base 0.575 inch ($2,300 \div 4,000$) therefrom; this is the shear line for the portion AB . Since the shear for any section in BC equals 1,300 pounds, we draw a line $b'c$ parallel to the base and

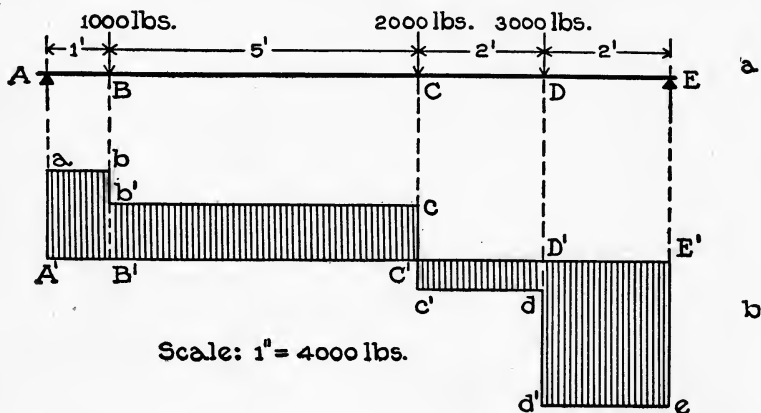

Fig. 13.

0.325 inch ($1,300 \div 4,000$) therefrom; this is the shear line for the portion BC . Since the shear for any section in CD is -700 pounds, we draw a line $c'd$ below the base and 0.175 inch ($700 \div 4,000$) therefrom; this is the shear line for the portion CD . Since the shear for any section in DE equals $-3,700$ lbs., we draw a line $d'e$ below the base and 0.925 inch ($3,700 \div 4,000$) therefrom; this is the shear line for the portion DE . Fig. 13, *b*, is the required shear diagram.

2. It is required to construct the shear diagram for the beam of Fig. 14, *a* (a copy of Fig. 9), taking into account the weight of the beam, 400 pounds.

The values of the shear for sections one foot apart were computed in example 3, Art. 37, so we have only to erect ordinates at the various points on a base line $A'E'$ (Fig. 14, *b*), equal to those

values. We shall use the same scale as in the preceding illustration, 4,000 pounds to an inch. Then the lengths of the ordinates corresponding to the values of the shear (see example 3, Art. 37) are respectively:

$$2,500 \div 4,000 = 0.625 \text{ inch}$$

$$2,460 \div 4,000 = 0.615 \text{ "}$$

$$1,460 \div 4,000 = 0.365 \text{ "}$$

etc. etc.

Laying these ordinates off from the base (upwards or downwards according as they correspond to positive or negative shears), we get ab , $b'e$, $c'd$, and $d'e$ as the shear lines.

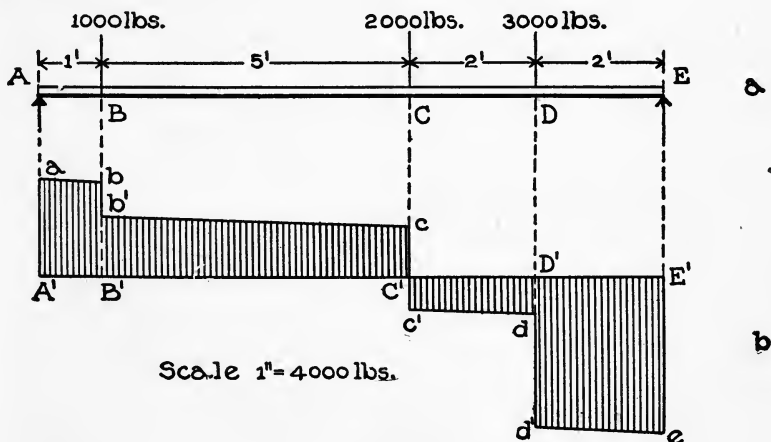

Fig. 14.

3. It is required to construct the shear diagram for the cantilever beam represented in Fig. 15, a , neglecting the weight of the beam.

The value of the shear for any section in AB is -500 pounds; for any section in BC , $-1,500$ pounds; and for any section in CD , $-3,500$ pounds. Hence the shear lines are ab , $b'e$, $c'd$. The scale being 5,000 pounds to an inch,

$$A'a = 500 \div 5,000 = 0.1 \text{ inch,}$$

$$B'b = 1,500 \div 5,000 = 0.3 \text{ "}$$

$$C'e = 3,500 \div 5,000 = 0.7 \text{ "}$$

The shear lines are all below the base because all the values of the shear are negative.

4. Suppose that the cantilever of the preceding illustration sustains also a uniform load of 200 pounds per foot (see Fig. 16, *a*). Construct a shear diagram.

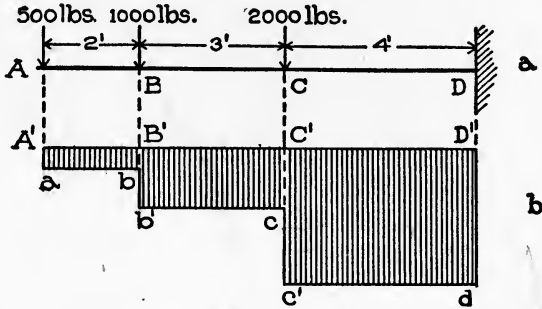

Scale 1"=5000 lbs.

Fig. 15.

First, we compute the values of the shear at several sections.

Thus

$$\begin{aligned}
 V_0'' &= -500 \text{ pounds,} \\
 V_1 &= -500 - 200 = -700, \\
 V_2' &= -500 - 200 \times 2 = -900, \\
 V_2'' &= -500 - 200 \times 2 - 1,000 = -1,900, \\
 V_3 &= -500 - 1,000 - 200 \times 3 = -2,100, \\
 V_4 &= -500 - 1,000 - 200 \times 4 = -2,300, \\
 V_5' &= -500 - 1,000 - 200 \times 5 = -2,500, \\
 V_5'' &= -500 - 1,000 - 200 \times 5 - 2,000 = -4,500, \\
 V_6 &= -500 - 1,000 - 2,000 - 200 \times 6 = -4,700, \\
 V_7 &= -500 - 1,000 - 2,000 - 200 \times 7 = -4,900, \\
 V_8 &= -500 - 1,000 - 2,000 - 200 \times 8 = -5,100, \\
 V_9 &= -500 - 1,000 - 2,000 - 200 \times 9 = -5,300.
 \end{aligned}$$

The values, being negative, should be plotted downward. To a scale of 5,000 pounds to the inch they give the shear lines *ab*, *b'c*, *c'd* (Fig. 16, *b*).

EXAMPLES FOR PRACTICE.

1. Construct a shear diagram for the beam represented in Fig. 10, neglecting the weight of the beam (see example 1, Art. 37).
2. Construct the shear diagram for the beam represented in Fig. 11, neglecting the weight of the beam (see example 3, Art. 37).

3. Construct the shear diagram for the beam of Fig. 12 when it sustains, in addition to the loads represented, its own weight, 800 pounds, and a uniform load of 500 pounds per foot (see example 4, Art. 37).

4. Figs. *a*, cases 1 and 2, Table B, represent two cantilever beams, the first bearing a concentrated load P at the free end, and the second a uniform load W . Figs. *b* are the corresponding shear diagrams. Take P and W equal to 1,000 pounds, and satisfy yourself that the diagrams are correct.

5. Figs. *a*, cases 3 and 4, same table, represent simple beams supported at their ends, the first bearing a concentrated

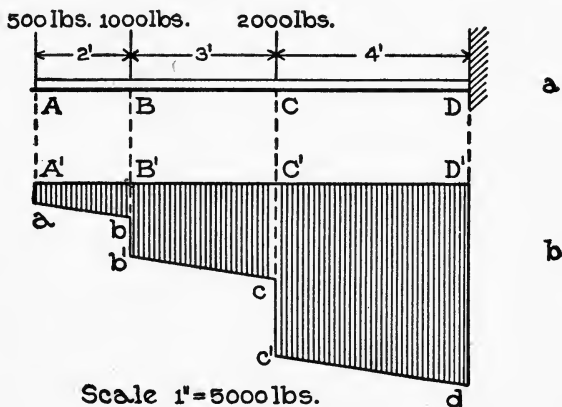

Fig. 16.

load P at the middle, and the second a uniform load W . Figs. *b* are the corresponding shear diagrams. Take P and W equal to 1,000 pounds, and satisfy yourself that they are correct.

39. Maximum Shear. It is sometimes desirable to know the greatest or maximum value of the shear in a given case. This value can always be found with certainty by constructing the shear diagram, from which the maximum value of the shear is evident at a glance. In any case it can most readily be computed if one knows the section for which the shear is a maximum. The student should examine all the shear diagrams in the preceding articles and those that he has drawn, and see that

1. *In cantilevers fixed in a wall, the maximum shear occurs at the wall.*

2. *In simple beams, the maximum shear occurs at a section next to one of the supports.*

By the use of these propositions one can determine the value of the maximum shear without constructing the whole shear diagram. Thus, it is easily seen (referring to the diagrams, page 53) that for a

Cantilever, end load P,	maximum shear = P
“ , uniform load W,	“ “ = W
Simple beam, middle load P,	“ “ = $\frac{1}{2}P$
“ “ , uniform “ W,	“ “ = $\frac{1}{2}W$

40. **Bending Moment.** By bending moment at (or for) a section of a loaded beam, is meant the algebraic sum of the moments of all the loads (including weight of beam) and reactions to the left or right of the section with respect to any point in the section.

41. **Rule of Signs.** We follow the rule of signs previously stated (Art. 29) that the moment of a force which tends to produce clockwise rotation is plus, and that of a force which tends to produce counter-clockwise rotation is minus; but in order to get the same sign for the bending moment whether computed from the right or left, we *change the sign* of the sum of the moments when computed from the loads and reactions *on the right*. Thus for section *a*, Fig. 8, the algebraic sums of the moments of the forces are:

when computed from the left,

$$-1,000 \times 5 + 3,000 \times 1 = -2,000 \text{ foot-pounds;}$$

and when computed from the right,

$$1,000 \times 19 - 3,000 \times 15 + 2,000 \times 13 + 2,000 \times 1 = +2,000 \text{ foot-pounds.}$$

The bending moment at section *a* is -2,000 foot-pounds.

Again, for section *b*, the algebraic sums of the moments of the forces are:

when computed from the left,

$$-1,000 \times 22 + 3,000 \times 18 - 2,000 \times 16 - 2,000 \times 4 + 3,000 \times 2 = -2,000 \text{ foot-pounds;}$$

and when computed from the right,

$$1,000 \times 2 = +2,000 \text{ foot-pounds.}$$

The bending moment at the section is -2,000 foot-pounds.

It is usually convenient to compute the bending moment for a section from the forces to the right or left according as there are fewer forces (loads and reactions) on the right or left side of the section.

42. Units. It is customary to express bending moments in inch-pounds, but often the foot-pound unit is more convenient. *To reduce foot-pounds to inch-pounds, multiply by twelve.*

43. Notation. We shall use M to denote bending moment at any section, and the bending moment at a particular section will be denoted by that letter subscripted; thus M_1 , M_2 , etc., denote values of the bending moment for sections one, two, etc., feet from the left end of the beam.

Examples. 1. Compute the bending moments for sections one foot apart in the beam represented in Fig. 9, neglecting the weight of the beam. (The right and left reactions are 3,700 and 2,300 pounds respectively. See example 1, Art. 33.)

Since there are no forces acting on the beam to the left of the left support, $M_0=0$. To the left of the section one foot from the left end there is but one force, the left reaction, and its arm is one foot; hence $M_1=+2,300 \times 1=2,300$ foot-pounds. To the left of a section two feet from the left end there are two forces, 2,300 and 1,000 pounds, and their arms are 2 feet and 1 foot respectively; hence $M_2=+2,300 \times 2-1,000 \times 1=3,600$ foot-pounds. At the left of all sections between B and C there are only two forces, 2,300 and 1,000 pounds; hence

$$M_3=+2,300 \times 3-1,000 \times 2=+4,900 \text{ foot-pounds,}$$

$$M_4=+2,300 \times 4-1,000 \times 3=+6,200 \quad \text{"}$$

$$M_5=+2,300 \times 5-1,000 \times 4=+7,500 \quad \text{"}$$

$$M_6=+2,300 \times 6-1,000 \times 5=+8,800 \quad \text{"}$$

To the right of a section seven feet from the left end there are two forces, the 3,000-pound load and the right reaction (3,700 pounds), and their arms with respect to an origin in that section are respectively one foot and three feet; hence

$$M_7=-(-3,700 \times 3+3,000 \times 1)=+8,100 \text{ foot-pounds.}$$

To the right of any section between E and D there is only one force, the right reaction; hence

$$M_8 = -(-3,700 \times 2) = 7,400 \text{ foot-pounds,}$$

$$M_9 = -(-3,700 \times 1) = 3,700 \quad "$$

Clearly $M_{10} = 0$.

2. A simple beam 10 feet long and supported at its ends weighs 400 pounds, and bears a uniformly distributed load of 1,600 pounds. Compute the bending moments for sections two feet apart.

Each reaction equals one-half the whole load, that is, $\frac{1}{2}$ of $(1,600 + 400) = 1,000$ pounds, and the load per foot including weight of the beam is 200 pounds. The forces acting on the beam to the left of the first section, two feet from the left end, are the left reaction (1,000 pounds) and the load (including weight) on the part of the beam to the left of the section (400 pounds). The arm of the reaction is 2 feet and that of the 400-pound force is 1 foot (the distance from the middle of the 400-pound load to the section). Hence

$$M_2 = +1,000 \times 2 - 400 \times 1 = +1,600 \text{ foot-pounds.}$$

The forces to the left of the next section, 4 feet from the left end, are the left reaction and all the load (including weight of beam) to the left (800 pounds). The arm of the reaction is 4 feet, and that of the 800-pound force is 2 feet; hence

$$M_4 = +1,000 \times 4 - 800 \times 2 = +2,400 \text{ foot-pounds.}$$

Without further explanation the student should see that

$$M_6 = +1,000 \times 6 - 1,200 \times 3 = +2,400 \text{ foot-pounds,}$$

$$M_8 = +1,000 \times 8 - 1,600 \times 4 = +1,600 \quad "$$

Evidently $M_0 = M_{10} = 0$.

3. Compute the values of the bending moment in example 1, taking into account the weight of the beam, 400 pounds. (The right and left reactions are respectively 3,900 and 2,500 pounds; see example 3, Art. 33.)

We proceed as in example 1, except that the moment of the weight of the beam to the left of each section (or to the right when computing from forces to the right) must be included in the respective moment equations. Thus, computing from the left,

$$M_0 = 0$$

$$M_1 = +2,500 \times 1 - 40 \times \frac{1}{2} = +2,480 \text{ foot-pounds,}$$

$$M_2 = +2,500 \times 2 - 1,000 \times 1 - 80 \times 1 = +3,920,$$

$$M_3 = +2,500 \times 3 - 1,000 \times 2 - 120 \times 1\frac{1}{2} = +5,320,$$

$$M_4 = +2,500 \times 4 - 1,000 \times 3 - 160 \times 2 = +6,680,$$

$$M_5 = +2,500 \times 5 - 1,000 \times 4 - 200 \times 2\frac{1}{2} = +8,000,$$

$$M_6 = +2,500 \times 6 - 1,000 \times 5 - 240 \times 3 = +9,280.$$

Computing from the right,

$$M_7 = -(-3,900 \times 3 + 3,000 \times 1 + 120 \times 1\frac{1}{2}) = +8,520,$$

$$M_8 = -(-3,900 \times 2 + 80 \times 1) = +7,720,$$

$$M_9 = -(-3,900 \times 1 + 40 \times \frac{1}{2}) = +3,880,$$

$$M_{10} = 0.$$

EXAMPLES FOR PRACTICE.

1. Compute the values of the bending moment for sections one foot apart, beginning one foot from the left end of the beam represented in Fig. 10, neglecting the weight of the beam. (The right and left reactions are 3,300 and 4,000 pounds respectively; see example 2, Art. 33.)

$$\text{Ans. (in foot-pounds) } \left\{ \begin{array}{l} M_1 = -2,100 \quad M_6 = +3,400 \quad M_{11} = +2,100 \quad M_{16} = -6,400 \\ M_2 = -4,200 \quad M_7 = +5,300 \quad M_{12} = +400 \quad M_{17} = -4,800 \\ M_3 = -2,300 \quad M_8 = +7,200 \quad M_{13} = -1,300 \quad M_{18} = -3,200 \\ M_4 = -400 \quad M_9 = +5,500 \quad M_{14} = -3,000 \quad M_{19} = -1,600 \\ M_5 = +1,500 \quad M_{10} = +3,800 \quad M_{15} = -4,700 \quad M_{20} = 0 \end{array} \right.$$

2. Solve the preceding example, taking into account the weight of the beam, 42 pounds per foot. (The right and left reactions are 3,780 and 4,360 pounds respectively; see example 4, Art. 33.)

$$\text{Ans. (in foot-pounds) } \left\{ \begin{array}{l} M_1 = -2,121 \quad M_6 = +4,084 \quad M_{11} = +2,799 \quad M_{16} = -6,736 \\ M_2 = -4,284 \quad M_7 = +6,071 \quad M_{12} = +976 \quad M_{17} = -4,989 \\ M_3 = -2,129 \quad M_8 = +8,016 \quad M_{13} = -889 \quad M_{18} = -3,284 \\ M_4 = -16 \quad M_9 = +6,319 \quad M_{14} = -2,796 \quad M_{19} = -1,621 \\ M_5 = +2,055 \quad M_{10} = +4,580 \quad M_{15} = -4,745 \quad M_{20} = 0 \end{array} \right.$$

3. Compute the bending moments for sections one foot apart, of the beam represented in Fig. 11, neglecting the weight. (The right and left reactions are 1,444 and 1,556 pounds respectively; see example 1, Art. 33.)

$$\text{Ans. (in foot-pounds)} \begin{cases} M_1 = +1,556 & M_5 = +5,980 & M_9 = +6,104 & M_{13} = +4,328 \\ M_2 = +3,112 & M_6 = +6,936 & M_{10} = +5,660 & M_{14} = +2,884 \\ M_3 = +4,068 & M_7 = +6,992 & M_{11} = +5,216 & M_{15} = +1,440 \\ M_4 = +5,024 & M_8 = +6,548 & M_{12} = +4,772 & M_{16} = 0 \end{cases}$$

4 Compute the bending moments at sections one foot apart in the beam of Fig. 12, taking into account the weight of the beam, 800 pounds, and a uniform load of 500 pounds per foot. (The right and left reactions are 4,870 and 11,930 pounds respectively; see Exs. 3 and 4, Art. 33.)

$$\text{Ans. (in foot-pounds)} \begin{cases} M_1 = -270 & M_6 = -19,720 & M_{11} = +3,980 & M_{16} = 12,180 \\ M_2 = -3,080 & M_7 = -13,300 & M_{12} = +6,700 & M_{17} = 12,200 \\ M_3 = -6,430 & M_8 = -7,420 & M_{13} = +8,880 & M_{18} = 8,680 \\ M_4 = -10,320 & M_9 = -3,080 & M_{14} = +10,520 & M_{19} = 4,620 \\ M_5 = -14,750 & M_{10} = +720 & M_{15} = +11,620 & M_{20} = 0 \end{cases}$$

44. **Moment Diagrams.** The way in which the bending moment varies from section to section in a loaded beam can be well represented by means of a diagram called a *moment diagram*. To construct such a diagram for any loaded beam,

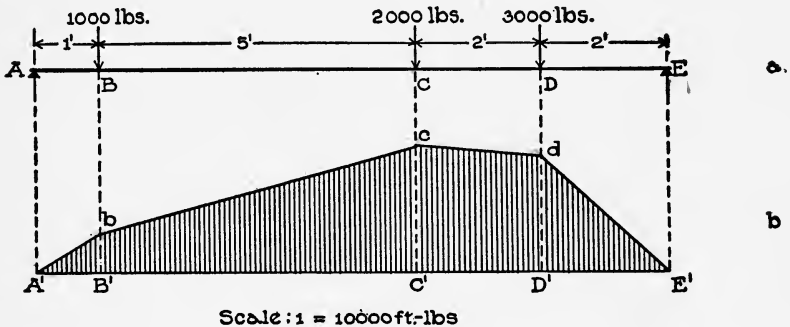

Fig. 17.

1. Lay off a base-line just as for a shear diagram (see Art. 38).

2. Draw a line such that the distance from any point of it to the base-line equals (by some scale) the value of the bending moment at the corresponding section of the beam, and so that the line is above the base where the bending moment is positive and below it where it is negative. (This line is called a "moment line.")

Examples. 1. It is required to construct a moment diagram for the beam of Fig. 17, *a* (a copy of Fig. 9), loaded as there shown.

Lay off $A'E'$ (Fig. 17, *b*) as a base. In example 1, Art. 43, we computed the values of the bending moment for sections one foot apart, so we erect ordinates at points of $A'E'$ one foot apart, to represent the bending moments.

We shall use a scale of 10,000 foot-pounds to the inch; then the ordinates (see example 1, Art. 43, for values of M) will be:

One foot from left end, $2,300 \div 10,000 = 0.23$ inch,

Two feet " " " $3,600 \div 10,000 = 0.36$ "

Three " " " " $4,900 \div 10,000 = 0.49$ "

Four " " " " $6,200 \div 10,000 = 0.62$ "

etc., etc.

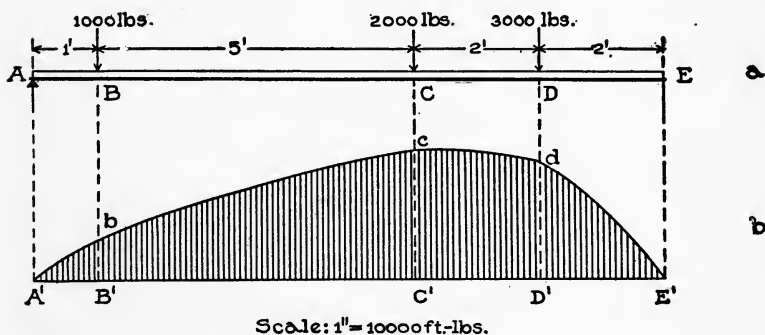

Fig. 18.

Laying these ordinates off, and joining their ends in succession, we get the line $A'bcdE'$, which is the bending moment line. Fig. 17, *b*, is the moment diagram.

2. It is required to construct the moment diagram for the beam, Fig. 18, *a* (a copy of Fig. 9), taking into account the weight of the beam, 400 pounds.

The values of the bending moment for sections one foot apart were computed in example 3, Art. 43. So we have only to lay off ordinates equal to those values, one foot apart, on the base $A'E'$ (Fig. 18, *b*).

To a scale of 10,000 foot-pounds to the inch the ordinates (see example 3, Art. 43, for values of M) are:

At left end, 0

One foot from left end, $2,480 \div 10,000 = 0.248$ inch

Two feet " " " $3,920 \div 10,000 = 0.392$ "

Three " " " " $5,320 \div 10,000 = 0.532$ "

Four " " " " $6,680 \div 10,000 = 0.668$ "

Laying these ordinates off at the proper points, we get $A'bedE$ as the moment line.

3. It is required to construct the moment diagram for the cantilever beam represented in Fig. 19, *a*, neglecting the weight of the beam. The bending moment at B equals

$$-500 \times 2 = -1,000 \text{ foot-pounds;}$$

at C,

$$-500 \times 5 - 1,000 \times 3 = -5,500;$$

and at D,

$$-500 \times 9 - 1,000 \times 7 - 2,000 \times 4 = -19,500.$$

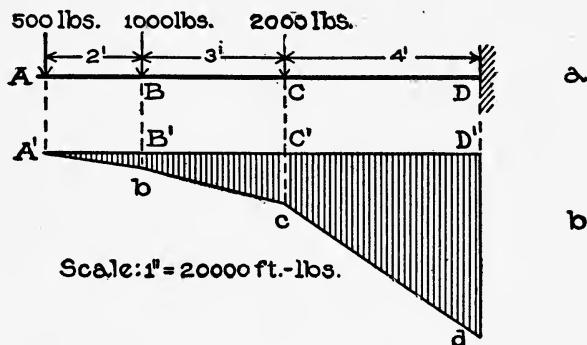

Fig. 19.

Using a scale of 20,000 foot-pounds to one inch, the ordinates in the bending moment diagram are:

$$\text{At B, } 1,000 \div 20,000 = 0.05 \text{ inch,}$$

$$\text{" C, } 5,500 \div 20,000 = 0.275 \text{ "}$$

$$\text{" D, } 19,500 \div 20,000 = 0.975 \text{ "}$$

Hence we lay these ordinates off, and downward because the bending moments are negative, thus fixing the points *b*, *c* and *d*. The bending moment at A is zero; hence the moment line connects A *b*, *c* and *d*. Further, the portions *Ab*, *bc* and *cd* are straight, as can be shown by computing values of the bending moment for sections in AB, BC and CD, and laying off the corresponding ordinates in the moment diagram.

4. Suppose that the cantilever of the preceding illustration sustains also a uniform load of 100 pounds per foot (see Fig. 20, *a*). Construct a moment diagram.

First, we compute the values of the bending moment at several sections; thus,

$$M_1 = -500 \times 1 - 100 \times \frac{1}{2} = -550 \text{ foot-pounds,}$$

$$M_2 = -500 \times 2 - 200 \times 1 = -1,200,$$

$$M_3 = -500 \times 3 - 1,000 \times 1 - 300 \times 1\frac{1}{2} = -2,950,$$

$$M_4 = -500 \times 4 - 1,000 \times 2 - 400 \times 2 = -4,800,$$

$$M_5 = -500 \times 5 - 1,000 \times 3 - 500 \times 2\frac{1}{2} = -6,750,$$

$$M_6 = -500 \times 6 - 1,000 \times 4 - 2,000 \times 1 - 600 \times 3 = -10,800,$$

$$M_7 = -500 \times 7 - 1,000 \times 5 - 2,000 \times 2 - 700 \times 3\frac{1}{2} = -14,950,$$

$$M_8 = -500 \times 8 - 1,000 \times 6 - 2,000 \times 3 - 800 \times 4 = -19,200,$$

$$M_9 = -500 \times 9 - 1,000 \times 7 - 2,000 \times 4 - 900 \times 4\frac{1}{2} = -23,550.$$

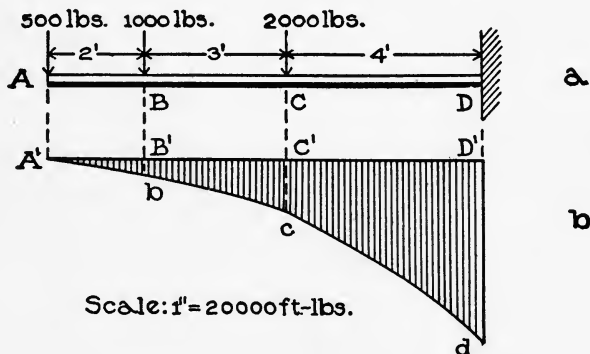

Fig. 20.

These values all being negative, the ordinates are all laid off downwards. To a scale of 20,000 foot-pounds to one inch, they fix the moment line $A'bcd$.

EXAMPLES FOR PRACTICE.

1. Construct a moment diagram for the beam represented in Fig. 10, neglecting the weight of the beam. (See example 1, Art. 43).
2. Construct a moment diagram for the beam represented in Fig. 11, neglecting the weight of the beam. (See example 3, Art. 43).
3. Construct the moment diagram for the beam of Fig. 12

when it sustains, in addition to the loads represented and its own weight (800 pounds), a uniform load of 500 pounds per foot. (See example 4, Art. 43.)

4. Figs. *a*, cases 1 and 2, page 53, represent two cantilever beams, the first bearing a load P at the free end, and the second a uniform load W . Figs. *c* are the corresponding moment diagrams. Take P and W equal to 1,000 pounds, and l equal to 10 feet, and satisfy yourself that the diagrams are correct.

5. Figs. *a*, cases 3 and 4, page 53, represent simple beams on end supports, the first bearing a middle load P , and the other a uniform load W . Figs. *c* are the corresponding moment diagrams. Take P and W equal to 1,000 pounds, and l equal to 10 feet, and satisfy yourself that the diagrams are correct.

45. Maximum Bending Moment. It is sometimes desirable to know the greatest or maximum value of the bending moment in a given case. This value can always be found with certainty by constructing the moment diagram, from which the maximum value of the bending moment is evident at a glance. But in any case, it can be most readily computed if one knows the section for which the bending moment is greatest. If the student will compare the corresponding shear and moment diagrams which have been constructed in foregoing articles (Figs. 13 and 17, 14 and 18, 15 and 19, 16 and 20), and those which he has drawn, he will see that—*The maximum bending moment in a beam occurs where the shear changes sign.*

By the help of the foregoing principle we can readily compute the maximum moment in a given case. We have only to construct the shear line, and observe from it where the shear changes sign; then compute the bending moment for that section. If a simple beam has one or more overhanging ends, then the shear changes sign more than once—twice if there is one overhanging end, and three times if two. In such cases we compute the bending moment for each section where the shear changes sign; the largest of the values of these bending moments is the maximum for the beam.

The section of maximum bending moment in a cantilever fixed at one end (as when built into a wall) is always at the wall.

Thus, without reference to the moment diagrams, it is readily seen that,

for a cantilever whose length is l ,

with an end load P , the maximum moment is Pl ,

“ a uniform “ W , “ “ “ “ $\frac{1}{2} Wl$.

Also by the principle, it is seen that,

for a beam whose length is l , on end supports,

with a middle load P , the maximum moment is $\frac{1}{4} Pl$,

“ uniform “ W , “ “ “ “ $\frac{1}{8} Wl$.

46. Table of Maximum Shears, Moments, etc. Table B on page 53 shows the shear and moment diagrams for eight simple cases of beams. The first two cases are built-in cantilevers; the next four, simple beams on end supports; and the last two, restrained beams built in walls at each end. In each case l denotes the length.

CENTER OF GRAVITY AND MOMENT OF INERTIA.

It will be shown later that the strength of a beam depends partly on the form of its cross-section. The following discussion relates principally to cross-sections of beams, and the results reached (like shear and bending moment) will be made use of later in the subject of strength of beams.

47. Center of Gravity of an Area. The student probably knows what is meant by, and how to find, the center of gravity of any flat disk, as a piece of tin. Probably his way is to balance the piece of tin on a pencil point, the point of the tin at which it so balances being the center of gravity. (Really it is midway between the surfaces of the tin and over the balancing point.) The center of gravity of the piece of tin, is also that point of it through which the resultant force of gravity on the tin (that is, the weight of the piece) acts.

By “center of gravity” of a plane area of any shape we mean that point of it which corresponds to the center of gravity of a piece of tin when the latter is cut out in the shape of the area. The center of gravity of a quite irregular area can be found most readily by balancing a piece of tin or stiff paper cut in the shape of the area. But when an area is simple in shape, or consists of parts which are simple, the center of gravity of the whole can be

found readily by computation, and such a method will now be described.

48. Principle of Moments Applied to Areas. Let Fig. 21 represent a piece of tin which has been divided off into any number of parts in any way, the weight of the whole being W , and that of the parts W_1, W_2, W_3 , etc. Let C_1, C_2, C_3 , etc., be the centers of gravity of the parts, C that of the whole, and c_1, c_2, c_3 , etc., and c the distances from those centers of gravity respectively to some line ($L L$) in the plane of the sheet of tin. When the tin is lying in a horizontal position, the moment of the weight of the entire piece about $L L$ is Wc , and the moments of the parts are W_1c_1, W_2c_2 , etc. Since the weight of the whole is the resultant of the weights of the parts, the moment of the weight of the whole equals the sum of the moments of the weights of the parts; that is,

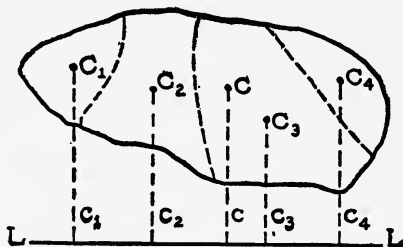

Fig. 21.

$$Wc = W_1c_1 + W_2c_2 + \text{etc.} \dots$$

Now let A_1, A_2 , etc. denote the areas of the parts of the pieces of tin, and A the area of the whole; then since the weights are proportional to the areas, we can replace the W 's in the preceding equation by corresponding A 's, thus:

$$Ac = A_1c_1 + A_2c_2 + \text{etc.} \dots \quad (4)$$

If we call the product of an area and the distance of its center of gravity from some line in its plane, the "moment" of the area with respect to that line, then the preceding equation may be stated in words thus:

The moment of an area with respect to any line equals the algebraic sum of the moments of the parts of the area.

If all the centers of gravity are on one side of the line with respect to which moments are taken, then all the moments should be given the plus sign; but if some centers of gravity are on one side and some on the other side of the line, then the moments of the areas whose centers of gravity are on one side should be given the

same sign, and the moments of the others the opposite sign. The foregoing is the principle of moments for areas, and it is the basis of all rules for finding the center of gravity of an area.

To find the center of gravity of an area which can be divided up into simple parts, we write the principle in forms of equations for two different lines as "axes of moments," and then solve the equations for the unknown distances of the center of gravity of the whole from the two lines. We explain further by means of specific examples.

Examples. 1. It is required to find the center of gravity of Fig. 22, *a*, the width being uniformly one inch.

The area can be divided into two rectangles. Let C_1 and

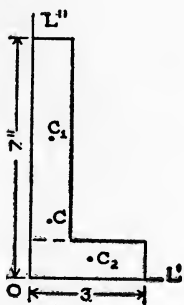

a

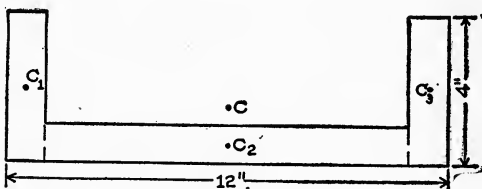

b

Fig. 22.

C_2 be the centers of gravity of two such parts, and C the center of gravity of the whole. Also let a and b denote the distances of C from the two lines OL' and OL'' respectively.

The areas of the parts are 6 and 3 square inches, and their arms with respect to OL' are 4 inches and $\frac{1}{2}$ inch respectively, and with respect to OL'' $\frac{1}{2}$ inch and $1\frac{1}{2}$ inches. Hence the equations of moments with respect to OL' and OL'' (the whole area being 9 square inches) are:

$$9 \times a = 6 \times 4 + 3 \times \frac{1}{2} = 25.5,$$

$$9 \times b = 6 \times \frac{1}{2} + 3 \times 1\frac{1}{2} = 7.5.$$

Hence,

$$a = 25.5 \div 9 = 2.83 \text{ inches,}$$

$$b = 7.5 \div 9 = 0.83 \text{ " .}$$

2. It is required to locate the center of gravity of Fig. 22, *b*, the width being uniformly one inch.

The figure can be divided up into three rectangles. Let C_1 , C_2 and C_3 be the centers of gravity of such parts, C the center of gravity of the whole; and let a denote the (unknown) distance of C from the base. The areas of the parts are 4, 10 and 4 square inches, and their "arms" with respect to the base are 2, $\frac{1}{2}$ and 2 inches respectively; hence the equation of moments with respect to the base (the entire area being 18 square inches) is:

$$18 \times a = 4 \times 2 + 10 \times \frac{1}{2} + 4 \times 2 = 21.$$

Hence, $a = 21 \div 18 = 1.17$ inches.

From the symmetry of the area it is plain that the center of gravity is midway between the sides.

EXAMPLE FOR PRACTICE.

1. Locate the center of gravity of Fig. 23.

Ans. 2.3 inches above the base.

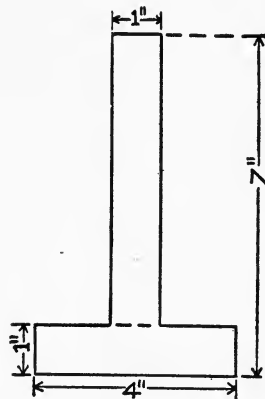

Fig. 23.

49. **Center of Gravity of Built-up Sections.** In Fig. 24 there are represented cross-sections of various kinds of rolled steel, called "shape steel," which is used extensively in steel construction. Manufacturers of this material publish "handbooks" giving full information in regard thereto, among other things, the position of the center of gravity of each cross section. With such a handbook

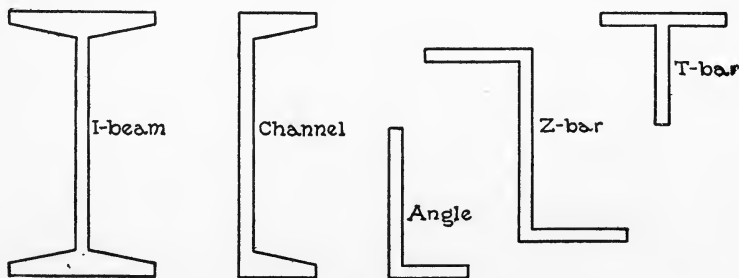

Fig. 24.

available, it is therefore not necessary actually to compute the position of the center of gravity of any section, as we did in the preceding article; but sometimes several shapes are riveted together to

make a "built-up" section (see Fig. 25), and then it may be necessary to compute the position of the center of gravity of the section.

Example. It is desired to locate the center of gravity of the section of a built-up beam represented in Fig. 25. The beam con-

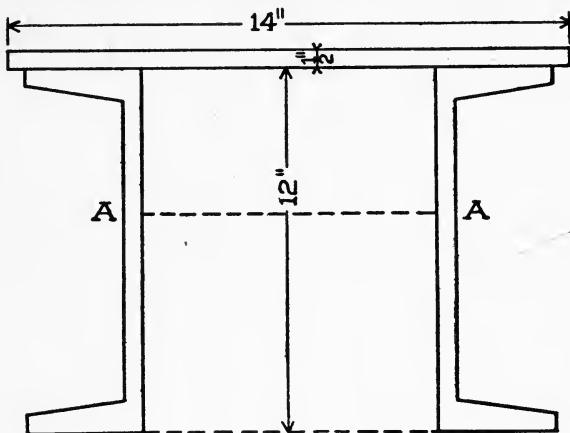

Fig. 25.

sists of two channels and a plate, the area of the cross-section of a channel being 6.03 square inches.

Evidently the center of gravity of each channel section is 6 inches, and that of the plate section is $12\frac{1}{4}$ inches, from the bottom.

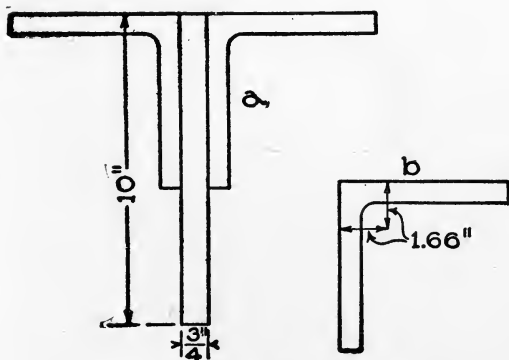

Fig. 26.

Let c denote the distance of the center of gravity of the whole section from the bottom; then since the area of the plate section is 7 square inches, and that of the whole section is 19.06,

$$\begin{aligned} 19.06 \times c &= 6.03 \times 6 + \\ &6.03 \times 6 + 7 \times 12\frac{1}{4} = \\ &158.11. \end{aligned}$$

Hence, $c = 158.11 \div 19.06 = 8.30$ inches. (about).

EXAMPLES FOR PRACTICE.

1. Locate the center of gravity of the built-up section of

Fig. 26, *a*, the area of each "angle" being 5.06 square inches, and the center of gravity of each being as shown in Fig. 26, *b*.

Ans. Distance from top, 3.08 inches.

2. Omit the left-hand angle in Fig. 26, *a*, and locate the center of gravity of the remainder.

Ans. $\left\{ \begin{array}{l} \text{Distance from top, 3.65 inches,} \\ \text{" " left side, 1.19 inches.} \end{array} \right.$

50. Moment of Inertia. If a plane area be divided into an infinite number of infinitesimal parts, then the sum of the products obtained by multiplying the area of each part by the square of its distance from some line is called the *moment of inertia* of the area with respect to the line. The line to which the distances are measured is called the *inertia-axis*; it may be taken anywhere in the plane of the area. In the subject of beams (where we have sometimes to compute the moment of inertia of the cross-section of a beam), the inertia-axis is taken through the center of gravity of the section and horizontal.

An approximate value of the moment of inertia of an area can be obtained by dividing the area into small parts (not infinitesimal), and adding the products obtained by multiplying the area of each part by the square of the distance from its center to the inertia-axis.

Example. If the rectangle of Fig. 27, *a*, is divided into 8 parts as shown, the area of each is one square inch, and the distances from the axis to the centers of gravity of the parts are $\frac{1}{2}$ and $1\frac{1}{2}$ inches. For the four parts lying nearest the axis the product (area times distance squared) is:

$$1 \times \left(\frac{1}{2}\right)^2 = \frac{1}{4}; \text{ and for the other parts it is}$$

$$1 \times \left(1\frac{1}{2}\right)^2 = \frac{9}{4}.$$

Hence the approximate value of the moment of inertia of the area with respect to the axis, is

$$4\left(\frac{1}{4}\right) + 4\left(\frac{9}{4}\right) = 10.$$

If the area is divided into 32 parts, as shown in Fig. 27, *b*, the area of each part is $\frac{1}{4}$ square inch. For the eight of the little squares farthest away from the axis, the distance from their centers of gravity to the axis is $1\frac{3}{4}$ inches; for the next eight it is $1\frac{1}{4}$; for the next eight $\frac{3}{4}$; and for the remainder $\frac{1}{4}$ inch. Hence an

approximate value of the moment of inertia of the rectangle with respect to the axis is:

$$8 \times \frac{1}{4} \times \left(1\frac{3}{4}\right)^2 + 8 \times \frac{1}{4} \times \left(1\frac{1}{4}\right)^2 + 8 \times \frac{1}{4} \times \left(\frac{3}{4}\right)^2 + 8 \times \frac{1}{4} \times \left(\frac{1}{4}\right)^2 = 10\frac{1}{2}.$$

If we divide the rectangle into still smaller parts and form the products

$$(\text{small area}) \times (\text{distance})^2,$$

and add the products just as we have done, we shall get a larger answer than $10\frac{1}{2}$. The smaller the parts into which the rectangle is divided, the larger will be the answer, but it will never be larger than $10\frac{2}{3}$. This $10\frac{2}{3}$ is the sum corresponding to a

division of the rectangle into an infinitely large number of parts (infinitely small) and it is the exact value of the moment of inertia of the rectangle with respect to the axis selected.

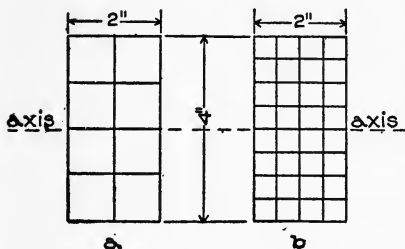

Fig. 27.

There are short methods of computing the exact values of the moments of inertia of simple figures (rectangles, circles, etc.),

but they cannot be given here since they involve the use of difficult mathematics. The foregoing method to obtain approximate values of moments of inertia is used especially when the area is quite irregular in shape, but it is given here to explain to the student the *meaning* of the moment of inertia of an area. He should understand now that the moment of inertia of an area is simply a name for such sums as we have just computed. The name is not a fitting one, since the sum has nothing whatever to do with inertia. It was first used in this connection because the sum is very similar to certain other sums which had previously been called moments of inertia.

51. Unit of Moment of Inertia. The product (area \times distance²) is really the product of four lengths, two in each factor; and since a moment of inertia is the sum of such products, a moment of inertia is also the product of four lengths. Now the product of two lengths is an area, the product of three is a volume, and the product of four is moment of inertia—unthinkable in

the way in which we can think of an area or volume, and therefore the source of much difficulty to the student. The units of these quantities (area, volume, and moment of inertia) are respectively:

the square inch, square foot, etc.,
 “ cubic “ , cubic “ “ ,
 “ biquadratic inch, biquadratic foot, etc.;

but the biquadratic inch is almost exclusively used in this connection; that is, the inch is used to compute values of moments of inertia, as in the preceding illustration. It is often written thus: Inches⁴.

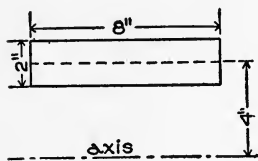

Fig. 28.

52. Moment of Inertia of a Rectangle.

Let b denote the base of a rectangle, and a its altitude; then by higher mathematics it can be shown that the moment of inertia

of the rectangle with respect to a line through its center of gravity and parallel to its base, is $\frac{1}{12} ba^3$.

Example. Compute the value of the moment of inertia of a rectangle 4×12 inches with respect to a line through its center of gravity and parallel to the long side.

Here $b=12$, and $a=4$ inches; hence the moment of inertia desired equals

$$\frac{1}{12}(12 \times 4^3) = 64 \text{ inches}^4.$$

EXAMPLE FOR PRACTICE.

1. Compute the moment of inertia of a rectangle 4×12 inches with respect to a line through its center of gravity and parallel to the short side. Ans. 576 inches⁴.

53. Reduction Formula. In the previously mentioned “handbooks” there can be found tables of moments of inertia of all the cross-sections of the kinds and sizes of rolled shapes made. The inertia-axes in those tables are always taken through the center of gravity of the section, and usually parallel to some edge of the section. Sometimes it is necessary to compute the moment of inertia of a “rolled section” with respect to some other axis, and if the two axes (that is, the one given in the tables, and the other) are parallel, then the desired moment of inertia can be easily computed from the one given in the tables by the following rule:

The moment of inertia of an area with respect to any axis equals the moment of inertia with respect to a parallel axis through the center of gravity, plus the product of the area and the square of the distance between the axes.

Or, if I denotes the moment of inertia with respect to any axis; I_0 the moment of inertia with respect to a parallel axis through the center of gravity; A the area; and d the distance between the axes, then

$$I = I_0 + Ad^2 \dots \quad (5)$$

Example. It is required to compute the moment of inertia of a rectangle 2×8 inches with respect to a line parallel to the long side and 4 inches from the center of gravity.

Let I denote the moment of inertia sought, and I_0 the moment of inertia of the rectangle with respect to a line parallel to the long side and through the center of gravity (see Fig. 28). Then

$$I_0 = \frac{1}{12}ba^3 \text{ (see Art. 52); and,}$$

since $b=8$ inches and $a=2$ inches,

$$I_0 = \frac{1}{12}(8 \times 2^3) = 5\frac{1}{3} \text{ biquadratic inches.}$$

The distance between the two inertia-axes is 4 inches, and the area of the rectangle is 16 square inches, hence equation 5 becomes

$$I = 5\frac{1}{3} + 16 \times 4^2 = 261\frac{1}{3} \text{ biquadratic inches.}$$

EXAMPLE FOR PRACTICE.

1. The moment of inertia of an "angle" $2\frac{1}{2} \times 2 \times \frac{1}{2}$ inches (lengths of sides and width respectively) with respect to a line through the center of gravity and parallel to the long side, is 0.64 inches⁴. The area of the section is 2 square inches, and the distance from the center of gravity to the long side is 0.63 inches. (These values are taken from a "handbook".) It is required to compute the moment of inertia of the section with respect to a line parallel to the long side and 4 inches from the center of gravity.

Ans. 32.64 inches⁴.

54. **Moment of Inertia of Built-up Sections.** As before stated, beams are sometimes "built up" of rolled shapes (angles,

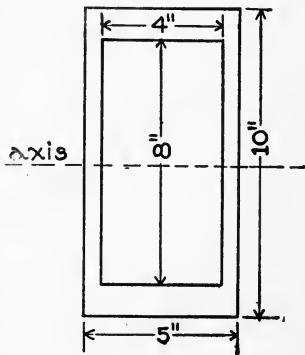

Fig. 29.

channels, etc.). The moment of inertia of such a section with respect to a definite axis is computed by adding the moments of inertia of the parts, *all with respect to that same axis*. This is the method for computing the moment of any area which can be divided into simple parts.

The moment of inertia of an area which may be regarded as consisting of a larger area *minus* other areas, is computed by subtracting from the moment of inertia of the large area those of the "minus areas."

Examples. 1. Compute the moment of inertia of the built-up section represented in Fig. 30 (in part same as Fig. 25) with respect to a horizontal axis passing through the center of gravity, it being given that the moment of inertia of each channel section with respect to a horizontal axis through its center of gravity is 128.1 inches⁴, and its area 6.03 square inches.

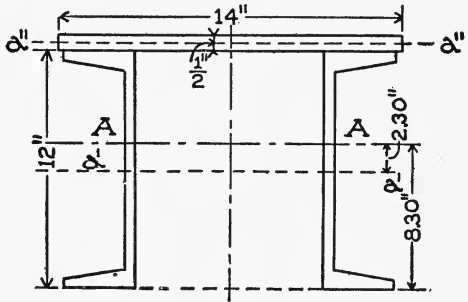

Fig. 30.

The center of gravity of the whole section was found in the example of Art. 49 to be 8.30 inches from the bottom of the section; hence the distances from the inertia-axis to the centers of gravity of the channel section and the plate are 2.30 and 3.95 inches respectively (see Fig. 30).

The moment of inertia of one channel section with respect to the axis AA (see equation 5, Art. 53) is:

$$128.1 + 6.03 \times 2.30^2 = 160.00 \text{ inches}^4.$$

The moment of inertia of the plate section (rectangle) with respect to the line $\alpha\alpha$ (see Art. 52) is:

$$\frac{1}{12} ba^3 = \frac{1}{12} [14 \times (\frac{1}{2})^3] = 0.15 \text{ inches}^4;$$

and with respect to the axis AA (the area being 7 square inches) it is:

$$0.15 + 7 \times 3.95^2 = 109.37 \text{ inches}^4.$$

Therefore the moment of inertia of the whole section with respect to AA is:

$$2 \times 160.00 + 109.37 = 429.37 \text{ inches}^4.$$

2. It is required to compute the moment of inertia of the "hollow rectangle" of Fig. 29 with respect to a line through the center of gravity and parallel to the short side.

The amount of inertia of the large rectangle with respect to the named axis (see Art. 52) is:

$$\frac{1}{12} (5 \times 10^3) = 416\frac{2}{3};$$

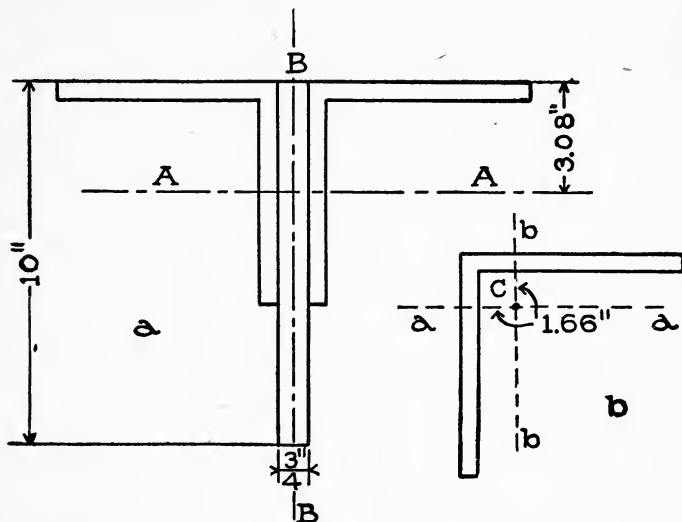

Fig. 31.

and the moment of inertia of the smaller one with respect to the same axis is:

$$\frac{1}{12} (4 \times 8^3) = 170\frac{2}{3};$$

hence the moment of inertia of the hollow section with respect to the axis is:

$$416\frac{2}{3} - 170\frac{2}{3} = 246 \text{ inches}^4.$$

EXAMPLES FOR PRACTICE.

1. Compute the moment of inertia of the section represented in Fig. 31, *a*, about the axis *AA*, it being 3.08 inches from the top. Given also that the area of one angle section is 5.06 square inches, its center of gravity *C* (Fig. 31, *b*) 1.66 inches from the top, and its moment of inertia with respect to the axis *aa* 17.68 inches⁴.
 Ans. 145.8 inches⁴.

2. Compute the moment of inertia of the section of Fig. 31, *a*,

with respect to the axis BB. Given that distance of the center of gravity of one angle from one side is 1.66 inches (see Fig. 31, *b*), and its moment of inertia with respect to *bb* 17.68 inches.







Ans. 77.618 inches⁴.

55. Table of Centers of Gravity and Moments of Inertia. Column 2 in Table A below gives the formula for moment of inertia with respect to the horizontal line through the center of gravity. The numbers in the third column are explained in Art. 62; and those in the fourth, in Art. 80.

TABLE A.

Moments of Inertia, Section Moduli, and Radii of Gyration.

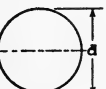
In each case the axis is horizontal and passes through the center of gravity.

Section.	Moment of Inertia.	Section Modulus.	Radius of Gyration.
	$\frac{a^4}{12}$	$\frac{a^3}{6}$	$\frac{a}{\sqrt{12}}$
	$\frac{a^4 - a_1^4}{12}$	$\frac{a^4 - a_1^4}{6a}$	$\sqrt{\frac{a^2 + a_1^2}{12}}$
	$\frac{ba^3}{12}$	$\frac{ba^2}{6}$	$\frac{a}{\sqrt{12}}$
	$\frac{ba^3 - b_1a_1^3}{12}$	$\frac{ba^3 - b_1a_1^3}{6a}$	$\sqrt{\frac{ba^3 - b_1a_1^3}{12(ba - b_1a_1)}}$
	$0.049d^4$	$0.098d^3$	$\frac{d}{4}$
	$0.049(d^4 - d_1^4)$	$0.098\frac{d^4 - d_1^4}{d}$	$\frac{\sqrt{d^2 + d_1^2}}{4}$

STRENGTH OF BEAMS.

56. Kinds of Loads Considered. The loads that are applied to a horizontal beam are usually vertical, but sometimes forces are applied otherwise than at right angles to beams. Forces acting on beams at right angles are called **transverse forces**; those applied

TABLE B.

Shear Diagrams (b) and Moment Diagrams (c) for Eight Different Cases (a). Also Values of Maximum Shear (V), Bending Moment (M), and Deflection (d).

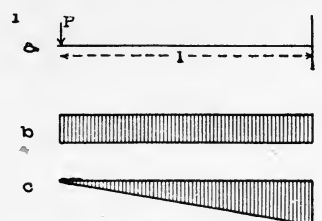
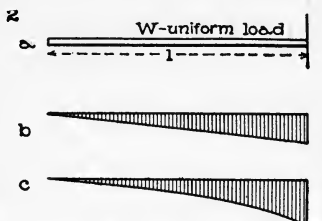
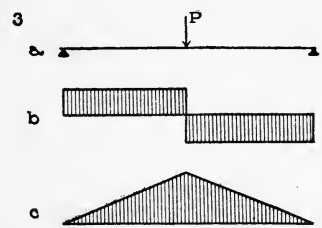
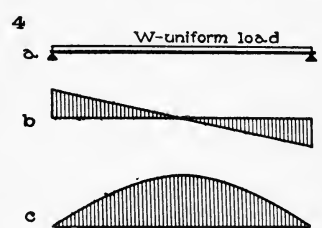
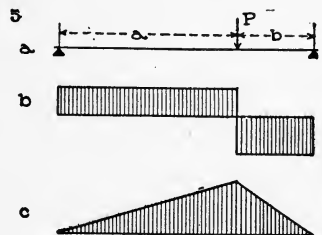
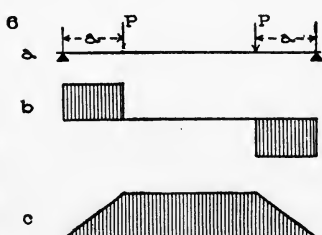
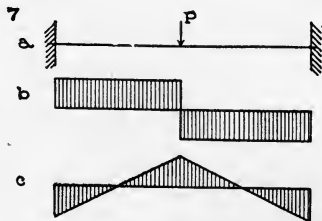
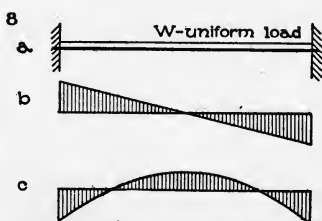
<p>1</p>  <p>$V = P, M = Pl, d = Pl^3 + 3EI.$</p>	<p>2</p>  <p>$V = W, M = \frac{1}{2} Wl, d = Wl^3 + 8EI.$</p>
<p>3</p>  <p>$V = \frac{1}{2} P, M = \frac{1}{4} Pl, d = Pl^3 + 48EI.$</p>	<p>4</p>  <p>$V = \frac{1}{2} W, M = \frac{5}{8} Wl, d = 5Wl^3 + 384EI.$</p>
<p>5</p>  <p>$V = Pa + l, M = Pab + l.$</p>	<p>6</p>  <p>$V = P, M = Pa, d = Pa (3l^2 - 4a^2) + 24EI.$</p>
<p>7</p>  <p>$V = \frac{1}{2} P, M = \frac{1}{8} Pl, d = Pl^3 + 192EI.$</p>	<p>8</p>  <p>$V = \frac{1}{2} W, M = \frac{1}{8} Wl, d = Wl^3 + 384EI.$</p>

parallel to a beam are called **longitudinal forces**; and others are called **inclined forces**. For the present we deal only with beams subjected to transverse forces (loads and reactions).

57. Neutral Surface, Neutral Line, and Neutral Axis. When a beam is loaded it may be wholly convex up (concave down), as a cantilever; wholly convex down (concave up), as a simple beam on end supports; or partly convex up and partly convex down, as a simple beam with overhanging ends, a restrained beam, or a con-

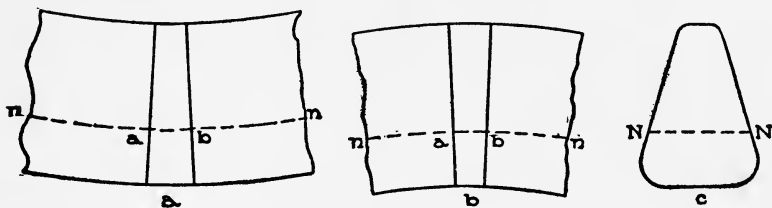

Fig. 32.

tinuous beam. Two vertical parallel lines drawn close together on the side of a beam before it is loaded will not be parallel after it is loaded and bent. If they are on a convex-down portion of a beam, they will be closer at the top and farther apart below than when drawn (Fig. 32a), and if they are on a convex-up portion, they will be closer below and farther apart above than when drawn (Fig. 32b).

The "fibres" on the convex side of a beam are stretched and therefore under tension, while those on the concave side are shortened and therefore under compression. Obviously there must be some intermediate fibres which are neither stretched nor shortened, *i. e.*, under neither tension nor compression. These make up a sheet of fibres and define a surface in the beam, which surface is called the **neutral surface** of the beam. The intersection of the neutral surface with either side of the beam is called the **neutral line**, and its intersection with any cross-section of the beam is called the **neutral axis** of that section. Thus, if ab is a fibre that has been neither lengthened nor shortened with the bending of the beam, then nn is a portion of the neutral line of the beam; and, if Fig. 32c be taken to represent a cross-section of the beam, NN is the neutral axis of the section.

It can be proved that *the neutral axis of any cross-section of*

a loaded beam passes through the center of gravity of that section, provided that all the forces applied to the beam are transverse, and that the tensile and compressive stresses at the cross-section are all within the elastic limit of the material of the beam.

58. Kinds of Stress at a Cross-section of a Beam. It has already been explained in the preceding article that there are tensile and compressive stresses in a beam, and that the tensions are on the convex side of the beam and the compressions on the concave (see Fig. 33). The forces T and C are exerted upon the portion of the beam represented by the adjoining portion to the

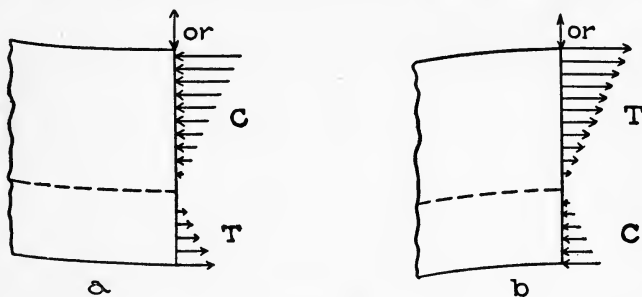

Fig. 33.

right (not shown). These, the student is reminded, are often called **fibre stresses**.

Besides the fibre stresses there is, in general, a shearing stress at every cross-section of a beam. This may be proved as follows:

Fig. 34 represents a simple beam on end supports which has actually been cut into two parts as shown. The two parts can maintain loads when in a horizontal position, if forces are applied at the cut ends equivalent to the forces that would act there if the beam were not cut. Evidently in the solid beam there are at the section a compression above and a tension below, and such forces can be applied in the cut beam by means of a short block C and a chain or cord T, as shown. The block furnishes the compressive forces and the chain the tensile forces. At first sight it appears as if the beam would stand up under its load after the block and chain have been put into place. Except in certain cases*, however, it would not remain in a horizontal position, as would the

* When the external shear for the section is zero.

solid beam. This shows that the forces exerted by the block and chain (horizontal compression and tension) are not equivalent to the actual stresses in the solid beam. What is needed is a vertical force at each cut end.

Suppose that R_1 is less than $L_1 + L_2 + \text{weight of } A$, *i. e.*, that the external shear for the section is negative; then, if vertical pulls be applied at the cut ends, upward on A and downward on B , the beam will stand under its load and in a horizontal position, just as a solid beam. These pulls can be supplied, in the model of the beam, by means of a cord S tied to two brackets fastened on A and

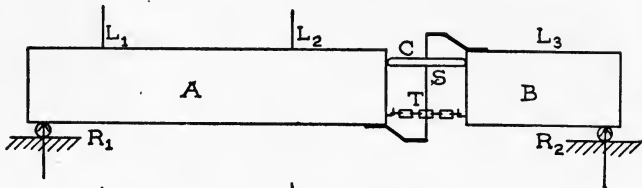

Fig. 34.

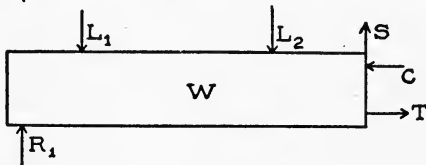

Fig. 35.

B , as shown. In the solid beam the two parts act upon each other directly, and the vertical forces are shearing stresses, since they act in the plane of the surfaces to which they are applied.

59. Relation Between the Stress at a Section and the Loads and Reactions on Either Side of It. Let Fig. 35 represent the portion of a beam on the left of a section; and let R_1 denote the left reaction; L_1 and L_2 the loads; W the weight of the left part; C , T , and S the compression, tension, and shear respectively which the right part exerts upon the left.

Since the part of the beam here represented is at rest, all the forces exerted upon it are balanced; and when a number of horizontal and vertical forces are balanced, then

1. The algebraic sum of the horizontal forces equals zero.
2. " " " " " vertical " " "
3. " " " " " moments of all the forces with respect to any point equals zero.

To satisfy condition 1, since the tension and compression are the only horizontal forces, *the tension must equal the compression.*

To satisfy condition 2, S (the internal shear) must equal the

algebraic sum of all the other vertical forces on the portion, that is, must equal the external shear for the section; also, S must act up or down according as the external shear is negative or positive. In other words, briefly expressed, *the internal and external shears at a section are equal and opposite.*

To satisfy condition 3, the algebraic sum of the moments of the fibre stresses about the neutral axis must be equal to the sum of the moments of all the other forces acting on the portion about the same line, and the signs of those sums must be opposite. (The moment of the shear about the neutral axis is zero.) Now, the sum of the moments of the loads and reactions is called the bending moment at the section, and if we use the term **resisting moment** to signify the sum of the moments of the fibre stresses (tensions and compressions) about the neutral axis, then we may say briefly that *the resisting and the bending moments at a section are equal, and the two moments are opposite in sign.*

60. The Fibre Stress. As before stated, the fibre stress is not a uniform one, that is, it is not uniformly distributed over the section on which it acts. At any section, the compression is most "intense" (or the unit-compressive stress is greatest) on the concave side; the tension is most intense (or the unit-tensile stress is greatest) on the convex side; and the unit-compressive and unit-tensile stresses decrease toward the neutral axis, at which place the unit-fibre stress is zero.

If the fibre stresses are within the elastic limit, then the two straight lines on the side of a beam referred to in Art. 57 will still be straight after the beam is bent; hence the elongations and shortenings of the fibres vary directly as their distance from the neutral axis. Since the stresses (if within the elastic limit) and deformations in a given material are proportional, *the unit-fibre stress varies as the distance from the neutral axis.*

Let Fig. 36*a* represent a portion of a bent beam, 36*b* its cross-section, nn the neutral line, and NN the neutral axis. The way in which the unit-fibre stress on the section varies can be represented graphically as follows: Lay off ac , by some scale, to represent the unit-fibre stress in the top fibre, and join c and n , extending the line to the lower side of the beam; also make bc' equal to bc'' and draw nc' . Then the arrows represent the unit-fibre stresses, for their lengths vary as their distances from the neutral axis.

61. Value of the Resisting Moment. If S denotes the unit-fibre stress in the fibre farthest from the neutral axis (the greatest unit-fibre stress on the cross-section), and c the distance from the neutral axis to the remotest fibre, while S_1, S_2, S_3 , etc., denote the unit-fibre stresses at points whose distances from the neutral axis are, respectively, y_1, y_2, y_3 , etc. (see Fig. 36*b*), then

$$S : S_1 :: c : y_1; \text{ or } S_1 = \frac{S}{c} y_1.$$

Also, $S_2 = \frac{S}{c} y_2; S_3 = \frac{S}{c} y_3$, etc.

Let a_1, a_2, a_3 , etc., be the areas of the cross-sections of the fibres

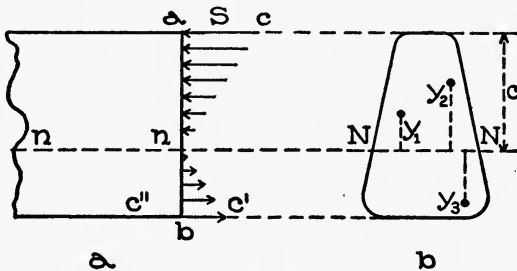

Fig. 36.

whose distances from the neutral axis are, respectively, y_1, y_2, y_3 , etc. Then the stresses on those fibres are, respectively,

$$S_1 a_1, S_2 a_2, S_3 a_3, \text{ etc.};$$

or, $\frac{S}{c} y_1 a_1, \frac{S}{c} y_2 a_2, \frac{S}{c} y_3 a_3$, etc.

The arms of these forces or stresses with respect to the neutral axis are, respectively, y_1, y_2, y_3 , etc.; hence their moments are

$$\frac{S}{c} a_1 y_1^2, \frac{S}{c} a_2 y_2^2, \frac{S}{c} a_3 y_3^2, \text{ etc.},$$

and the sum of the moments (that is, the resisting moment) is

$$\frac{S}{c} a_1 y_1^2 + \frac{S}{c} a_2 y_2^2 + \text{etc.} = \frac{S}{c} (a_1 y_1^2 + a_2 y_2^2 + \text{etc.})$$

Now $a_1 y_1^2 + a_2 y_2^2 + \text{etc.}$ is the sum of the products obtained by multiplying each infinitesimal part of the area of the cross-section by the square of its distance from the neutral axis; hence, it is the moment of inertia of the cross-section with respect to the neutral axis. If this moment is denoted by I , then the value of the resisting moment is $\frac{SI}{c}$.

STRENGTH OF MATERIALS.

PART II.

STRENGTH OF BEAMS---(Concluded).

62. First Beam Formula. As shown in the preceding article, the resisting and bending moments for any section of a beam are equal; hence

$$\frac{SI}{c} = M, \quad (6)$$

all the symbols referring to the same section. This is the most important formula relating to beams, and will be called the "first beam formula."

The ratio $I \div c$ is now quite generally called the **section modulus**. Observe that for a given beam it depends only on the dimensions of the cross-section, and not on the material or anything else. Since I is the product of four lengths (see article 51), $I \div c$ is the product of three; and hence a section modulus can be expressed in units of volume. The cubic inch is practically always used; and in this connection it is written thus, inches³. See Table A, page 52, for values of the section moduli of a few simple sections.

63. Applications of the First Beam Formula. There are three principal applications of equation 6, which will now be explained and illustrated.

64. First Application. The dimensions of a beam and its manner of loading and support are given, and it is required to compute the greatest unit-tensile and compressive stresses in the beam.

This problem can be solved by means of equation 6, written in this form,

$$S = \frac{Mc}{I} \text{ or } \frac{M}{I \div c} \quad (6')$$

Unless otherwise stated, we assume that the beams are uniform in cross-section, as they usually are; then the section modulus ($I \div c$) is the same for all sections, and S (the unit-fibre stress on

the remotest fibre) varies just as M varies, and is therefore greatest where M is a maximum.* Hence, to compute the value of the greatest unit-fibre stress in a given case, *substitute the values of the section modulus and the maximum bending moment in the preceding equation, and reduce.*

If the neutral axis is equally distant from the highest and lowest fibres, then the greatest tensile and compressive unit-stresses are equal, and their value is S . If the neutral axis is unequally distant from the highest and lowest fibres, let c' denote its distance from the nearer of the two, and S' the unit-fibre stress there. Then, since the unit-stresses in a cross-section are proportional to the distances from the neutral axis,

$$\frac{S'}{S} = \frac{c'}{c}, \text{ or } S' = \frac{c'}{c}S.$$

If the remotest fibre is on the convex side of the beam, S is tensile and S' compressive; if the remotest fibre is on the concave side, S is compressive and S' tensile.

Examples. 1. A beam 10 feet long is supported at its ends, and sustains a load of 4,000 pounds two feet from the left end (Fig. 37, *a*). If the beam is 4×12 inches in cross-section (the long side vertical as usual), compute the maximum tensile and compressive unit-stresses.

The section modulus of a rectangle whose base and altitude are b and a respectively (see Table A, page 52), is $\frac{1}{6}ba^2$; hence, for the beam under consideration, the modulus is

$$\frac{1}{6} \times 4 \times 12^2 = 96 \text{ inches}^3.$$

To compute the maximum bending moment, we have, first, to find the dangerous section. This section is where the shear changes sign (see article 45); hence, we have to construct the shear diagram, or as much thereof as is needed to find where the change of sign occurs. Therefore we need the values of the reaction. Neglecting the weight of the beam, the moment equation with origin at C (Fig. 37, *a*) is

$$R_1 \times 10 - 4,000 \times 8 = 0, \text{ or } R_1 = 3,200 \text{ pounds}$$

* NOTE. Because S is greatest in the section where M is maximum, this section is usually called the "dangerous section" of the beam.

Then, constructing the shear diagram, we see (Fig. 37, *b*) that the change of sign of the shear (also the dangerous section) is at the load. The value of the bending moment there is

$$3,200 \times 2 = 6,400 \text{ foot-pounds,}$$

$$\text{or} \quad 6,400 \times 12 = 76,800 \text{ inch-pounds.}$$

Substituting in equation 6', we find that

$$S = \frac{76,800}{96} = 800 \text{ pounds per square inch.}$$

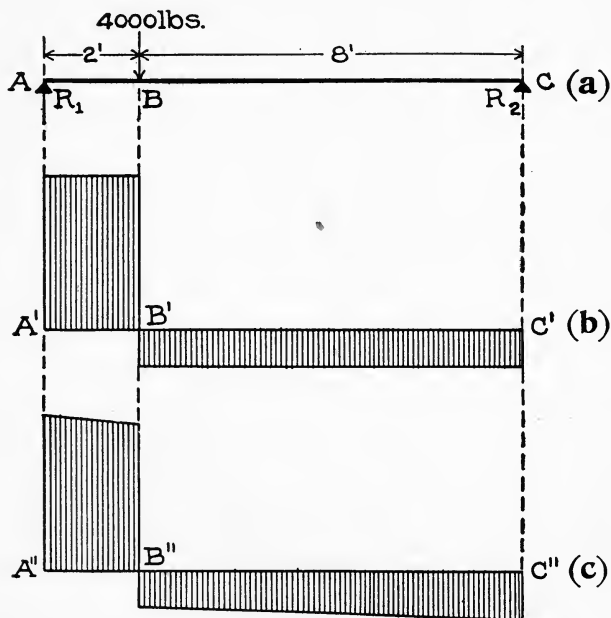

Fig. 37.

2. It is desired to take into account the weight of the beam in the preceding example, supposing the beam to be wooden.

The volume of the beam is

$$\frac{4 \times 12}{144} \times 10 = 3\frac{1}{3} \text{ cubic feet;}$$

and supposing the timber to weigh 45 pounds per cubic foot, the beam weighs 150 pounds (insignificant compared to the load).

The left reaction, therefore, is

$$3,200 + \left(\frac{1}{2} \times 150\right) = 3,275;$$

and the shear diagram looks like Fig. 37, *c*, the shear changing sign at the load as before. The weight of the beam to the left of the dangerous section is 30 pounds; hence the maximum bending moment equals

$$3,275 \times 2 - 30 \times 1 = 6,520 \text{ foot-pounds,}$$

$$\text{or } 6,520 \times 12 = 78,240 \text{ inch-pounds.}$$

Substituting in equation 6', we find that

$$S = \frac{78,240}{96} = 815 \text{ pounds per square inch.}$$

The weight of the beam therefore increases the unit-stress produced by the load at the dangerous section by 15 pounds per square inch.

3. A T-bar (see Fig. 38) 8 feet long and supported at each

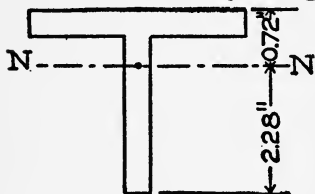

Fig. 38.

end, bears a uniform load of 1,200 pounds. The moment of inertia of its cross-section with respect to the neutral axis being 2.42 inches⁴, compute the maximum tensile and compressive unit-stresses in the beam

Evidently the dangerous section is in the middle, and the value of the maximum bending moment (see Table B, page 53, Part I) is $\frac{1}{8} Wl$, W and l denoting the load and length respectively. Here

$$\frac{1}{8} Wl = \frac{1}{8} \times 1,200 \times 8 = 1,200 \text{ foot-pounds,}$$

$$\text{or } 1,200 \times 12 = 14,400 \text{ inch-pounds.}$$

The section modulus equals $2.42 \div 2.28 = 1.06$; hence

$$S = \frac{14,400}{1.06} = 13,585 \text{ pounds per square inch.}$$

This is the unit-fibre stress on the lowest fibre at the middle section, and hence is tensile. On the highest fibre at the middle section the unit-stress is compressive, and equals (see page 60):

$$S' = \frac{c'}{c} S = \frac{0.72}{2.28} \times 13,585 = 4,290 \text{ pounds per square inch.}$$

EXAMPLES FOR PRACTICE.

1. A beam 12 feet long and 6×12 inches in cross-section rests on end supports, and sustains a load of 3,000 pounds in the middle. Compute the greatest tensile and compressive unit-stresses in the beam, neglecting the weight of the beam.

Ans. 750 pounds per square inch.

2. Solve the preceding example taking into account the weight of the beam, 300 pounds

Ans. 787.5 pounds per square inch.

3. Suppose that a built-in cantilever projects 5 feet from the wall and sustains an end load of 250 pounds. The cross-section of the cantilever being represented in Fig. 38, compute the greatest tensile and compressive unit-stresses, and tell at what places they occur. (Neglect the weight.)

Ans. $\left\{ \begin{array}{l} \text{Tensile,} \quad 4,471 \text{ pounds per square inch.} \\ \text{Compressive, } 14,150 \quad " \quad " \quad " \quad " \end{array} \right.$

4. Compute the greatest tensile and compressive unit-stresses in the beam of Fig. 18, *a*, due to the loads and the weight of beam (400 pounds). (A moment diagram is represented in Fig. 18, *b*; for description see example 2, Art. 44, p. 39.) The section of the beam is a rectangle 8×12 inches.

Ans. 580 pounds per square inch.

5. Compute the greatest tensile and compressive unit-stresses in the cantilever beam of Fig. 19, *a*, it being a steel I-beam whose section modulus is 20.4 inches³. (A bending moment diagram for it is represented in Fig. 19, *b*; for description, see Ex. 3, Art. 44.)

Ans. 11,470 pounds per square inch.

6. Compute the greatest tensile and compressive unit-stresses in the beam of Fig. 10, neglecting its weight, the cross-sections being rectangular 6×12 inches. (See example for practice 1, Art. 43.)

Ans. 600 pounds per square inch.

65. *Second Application.* The dimensions and the working strengths of a beam are given, and it is required to determine its safe load (the manner of application being given).

This problem can be solved by means of equation 6 written in this form,

$$M = \frac{SI}{c} \quad (6'')$$

We substitute for S the given working strength for the material of the beam, and for I and c their values as computed from the given dimensions of the cross-section; then reduce, thus obtaining the value of the safe resisting moment of the beam, which equals the greatest safe bending moment that the beam can stand. We next compute the value of the maximum bending moment in terms of the unknown load; equate this to the value of the resisting moment previously found; and solve for the unknown load.

In cast iron, the tensile and compressive strengths are very different; and the smaller (the tensile) should always be used if the neutral surface of the beam is midway between the top and bottom of the beam; but if it is unequally distant from the top and bottom, proceed as in example 4, following.

Examples. 1. A wooden beam 12 feet long and 6×12 inches in cross-section rests on end supports. If its working strength is 800 pounds per square inch, how large a load uniformly distributed can it sustain?

The section modulus is $\frac{1}{6}ba^2$, b and a denoting the base and altitude of the section (see Table A, page 52); and here

$$\frac{1}{6}ba^2 = \frac{1}{6} \times 6 \times 12^2 = 144 \text{ inches}^3.$$

Hence
$$S \frac{I}{c} = 800 \times 144 = 115,200 \text{ inch-pounds.}$$

For a beam on end supports and sustaining a uniform load, the maximum bending moment equals $\frac{1}{8}Wl$ (see Table B, page 55), W denoting the sum of the load and weight of beam, and l the length. If W is expressed in pounds, then

$$\frac{1}{8}Wl = \frac{1}{8}W \times 12 \text{ foot-pounds} = \frac{1}{8}W \times 144 \text{ inch-pounds.}$$

Hence, equating the two values of maximum bending moment and the safe resisting moment, we get

$$\frac{1}{8}W \times 144 = 115,200;$$

or,
$$W = \frac{115,200 \times 8}{144} = 6,400 \text{ pounds.}$$

The safe load for the beam is 6,400 pounds minus the weight of the beam.

2. A steel I-beam whose section modulus is 20.4 inches³ rests on end supports 15 feet apart. Neglecting the weight of the beam, how large a load may be placed upon it 5 feet from one end, if the working strength is 16,000 pounds per square inch?

The safe resisting moment is

$$\frac{SI}{c} = 16,000 \times 20.4 = 326,400 \text{ inch-pounds};$$

hence the bending moment must not exceed that value. The dangerous section is under the load; and if P denotes the unknown value of the load in pounds, the maximum moment (see Table B, page 53, Part I) equals $\frac{2}{3} P \times 5$ foot-pounds, or $\frac{2}{3} P \times 60$ inch-pounds. Equating values of bending and resisting moments, we get

$$\frac{2}{3} P \times 60 = 326,400;$$

or,
$$P = \frac{326,400 \times 3}{2 \times 60} = 8,160 \text{ pounds.}$$

3. In the preceding example, it is required to take into account the weight of the beam. 375 pounds.

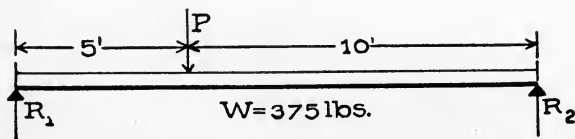

Fig. 39.

As we do not know the value of the safe load, we cannot construct the shear diagram and thus determine where the dangerous section is. But in cases like this, where the distributed load (the weight) is small compared with the concentrated load, the dangerous section is practically always where it is under the concentrated load alone; in this case, at the load. The reactions due to the weight equal $\frac{1}{2} \times 375 = 187.5$; and the reactions due to the load equal $\frac{1}{3} P$ and $\frac{2}{3} P$, P denoting the value of the load. The larger reaction R_1 (Fig. 39) hence equals $\frac{2}{3} P + 187.5$. Since

the weight of the beam per foot is $375 \div 15 = 25$ pounds, the maximum bending moment (at the load) equals

$$\left(\frac{2}{3} P + 187.5 \right) 5 - (25 \times 5) 2\frac{1}{2} =$$

$$\frac{10}{3} P + 937.5 - 312.5 = \frac{10}{3} P + 625.$$

This is in foot-pounds if P is in pounds.

The safe resisting moment is the same as in the preceding illustration, 326,400 inch-pounds; hence

$$\left(\frac{10}{3} P + 625 \right) 12 = 326,400.$$

Solving for P , we have

$$\frac{10}{3} P + 625 = \frac{326,400}{12};$$

$$10 P + 625 \times 3 = \frac{326,400 \times 3}{12} = 81,600;$$

$$10 P = 79,725;$$

or, $P = 7,972.5$ pounds.

It remains to test our assumption that the dangerous section is at the load. This can be done by computing R_1 (with $P = 7,972.5$), constructing the shear diagram, and noting where the shear changes sign. It will be found that the shear changes sign at the load, thus verifying the assumption.

4. A cast-iron built-in cantilever beam projects 8 feet from the wall. Its cross-section is represented in Fig. 40, and the

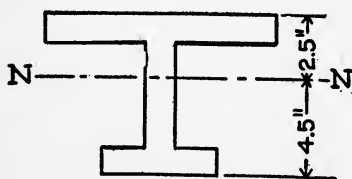

Fig. 40.

moment of inertia with respect to the neutral axis is 50 inches⁴; the working strengths in tension and compression are 2,000 and 9,000 pounds per square inch respectively. Compute the safe uniform load which the beam can sustain,

neglecting the weight of the beam.

The beam being convex up, the upper fibres are in tension and the lower in compression. The resisting moment ($SI \div c$), as determined by the compressive strength, is

$$\frac{9,000 \times 50}{4.5} = 100,000 \text{ inch-pounds;}$$

and the resisting moment, as determined by the tensile strength, is

$$\frac{2,000 \times 50}{2.5} = 40,000 \text{ inch-pounds.}$$

Hence the safe resisting moment is the lesser of these two, or 40,000 inch-pounds. The dangerous section is at the wall (see Table B, page 53), and the value of the maximum bending moment is $\frac{1}{2} Wl$, W denoting the load and l the length. If W is in pounds, then

$$M = \frac{1}{2} W \times 8 \text{ foot-pounds} = \frac{1}{2} W \times 96 \text{ inch-pounds.}$$

Equating bending and resisting moments, we have

$$\frac{1}{2} W \times 96 = 40,000;$$

or,
$$W = \frac{40,000 \times 2}{96} = 833 \text{ pounds.}$$

EXAMPLES FOR PRACTICE.

1. An 8×8 -inch timber projects 8 feet from a wall. If its working strength is 1,000 pounds per square inch, how large an end load can it safely sustain?

Ans. 890 pounds. ✓

2. A beam 12 feet long and 8×16 inches in cross-section, on end supports, sustains two loads P , each 3 feet from its ends respectively. The working strength being 1,000 pounds per square inch, compute P (see Table B, page 53).

Ans. 9,480 pounds. ✓

3. An I-beam weighing 25 pounds per foot rests on end supports 20 feet apart. Its section modulus is 20.4 inches³, and its working strength 16,000 pounds per square inch. Compute the safe uniform load which it can sustain.

Ans. 10,880 pounds. ✓

66. *Third Application.* The loads, manner of support, and working strength of beam are given, and it is required to determine the size of cross-section necessary to sustain the load safely, that is, to "design the beam."

To solve this problem, we use the first beam formula (equation 6), written in this form,

$$\frac{I}{c} = \frac{M}{S}. \quad (6''')$$

We first determine the maximum bending moment, and then substitute its value for M , and the working strength for S . Then we have the value of the section modulus ($I \div c$) of the required beam. Many cross-sections can be designed, all having a given section modulus. Which one is to be selected as most suitable will depend on the circumstances attending the use of the beam and on considerations of economy.

Examples. 1. A timber beam is to be used for sustaining a uniform load of 1,500 pounds, the distance between the supports being 20 feet. If the working strength of the timber is 1,000 pounds per square inch, what is the necessary size of cross-section?

The dangerous section is at the middle of the beam; and the maximum bending moment (see Table B, page 53) is

$$\frac{1}{8} Wl = \frac{1}{8} \times 1,500 \times 20 = 3,750 \text{ foot-pounds,}$$

or $3,750 \times 12 = 45,000 \text{ inch-pounds.}$

Hence $\frac{I}{c} = \frac{45,000}{1,000} = 45 \text{ inches}^3.$

Now the section modulus of a rectangle is $\frac{1}{6}ba^2$ (see Table A, page 54, Part I); therefore, $\frac{1}{6}ba^2 = 45$, or $ba^2 = 270$.

Any wooden beam (safe strength 1,000 pounds per square inch) whose breadth times its depth square equals or exceeds 270, is strong enough to sustain the load specified, 1,500 pounds.

To determine a size, we may choose any value for b or a , and solve the last equation for the unknown dimension. It is best, however, to select a value of the breadth, as 1, 2, 3, or 4 inches, and solve for a . Thus, if we try $b = 1$ inch, we have

$$a^2 = 270, \text{ or } a = 16.43 \text{ inches.}$$

This would mean a board 1×18 inches, which, if used, would have to be supported sidewise so as to prevent it from tipping or "buckling." Ordinarily, this would not be a good size.

Next try $b = 2$ inches; we have

$$2 \times a^2 = 270; \text{ or } a = \sqrt{270 \div 2} = 11.62 \text{ inches.}$$

This would require a plank 2×12 , a better proportion than the first. Trying $b = 3$ inches, we have

$$3 \times a^2 = 270; \text{ or } a = \sqrt{270 \div 3} = 9.49 \text{ inches.}$$

This would require a plank 3×10 inches; and a choice between a 2×12 and a 3×10 plank would be governed by circumstances in the case of an actual construction.

It will be noticed that we have neglected the weight of the beam. Since the dimensions of wooden beams are not fractional, and we have to select a commercial size next larger than the one computed (12 inches instead of 11.62 inches, for example), the additional depth is usually sufficient to provide strength for the weight of the beam. If there is any doubt in the matter, we can settle it by computing the maximum bending moment including the weight of the beam, and then computing the greatest unit-fibre stress due to load and weight. If this is less than the safe strength, the section is large enough; if greater, the section is too small.

Thus, let us determine whether the 2×12 -inch plank is strong enough to sustain the load and its own weight. The plank will weigh about 120 pounds, making a total load of

$$1,500 + 120 = 1,620 \text{ pounds.}$$

Hence the maximum bending moment is

$$\frac{1}{8}Wl = \frac{1}{8}1,620 \times 20 \times 12 = 48,600 \text{ inch-pounds.}$$

Since $\frac{I}{c} = \frac{1}{6}ba^2 = \frac{1}{6} \times 2 \times 12^2 = 48$, and $S = \frac{M}{I \div c}$,

$$S = \frac{48,600}{48} = 1,013 \text{ pounds per square inch.}$$

Strictly, therefore, the 2×12 -inch plank is not large enough; but as the greatest unit-stress in it would be only 13 pounds per square inch too large, its use would be permissible.

2. What size of steel I-beam is needed to sustain safely the loading of Fig. 9 if the safe strength of the steel is 16,000 pounds per square inch?

The maximum bending moment due to the loads was found in example 1, Art. 43, to be 8,800 foot-pounds, or $8,800 \times 12 = 105,600$ inch-pounds.

$$\text{Hence } \frac{I}{c} = \frac{105,600}{16,000} = 6.6 \text{ inches}^2.$$

That is, an I-beam is needed whose section modulus is a little larger than 6.6, to provide strength for its own weight.

To select a size, we need a descriptive table of I-beams, such as is published in handbooks on structural steel.

Below is an abridged copy of such a table. (The last two columns contain information for use later.) The figure illustrates a cross-section of an I-beam, and shows the axes referred to in the table.

It will be noticed that two sizes are given for each depth; these are the lightest and heaviest of each size that are made, but intermediate sizes can be secured. In column 5 we find 7.3 as the next larger section modulus than the one required (6.6); and this corresponds to a $12\frac{1}{4}$ -pound 6-inch I-beam, which is probably the proper size. To ascertain whether the excess ($7.3 - 6.6 = 0.70$) in the section modulus is sufficient to provide for the weight of the beam, we might proceed as in example 1. In this case, however, the excess is quite large, and the beam selected is doubtless safe.

TABLE C.
Properties of Standard I-Beams



Section of beam, showing axes 1-1 and 2-2.

1	2	3	4	5	6
Depth of Beam, in inches.	Weight per foot, in pounds.	Area of cross-section, in square inches.	Moment of inertia, axis 1-1.	Section modulus, axis 1-1.	Moment of inertia, axis 2-2.
3	5.50	1.63	2.5	1.7	0.46
3	7.50	2.21	2.9	1.9	.60
4	7.50	2.21	6.0	3.0	.77
4	10.50	3.09	7.1	3.6	1.01
5	9.75	2.87	12.1	4.8	1.23
5	14.75	4.34	15.1	6.1	1.70
6	12.25	3.61	21.8	7.3	1.85
6	17.25	5.07	26.2	8.7	2.36
7	15.00	4.42	36.2	10.4	2.67
7	20.00	5.88	42.2	12.1	3.24
8	18.00	5.33	56.9	14.2	3.78
8	25.25	7.43	68.0	17.0	4.71
9	21.00	6.31	84.9	18.9	5.16
9	35.00	10.29	111.8	24.8	7.31
10	25.00	7.37	122.1	24.4	6.89
10	40.00	11.76	158.7	31.7	9.50
12	31.50	9.26	215.8	36.0	9.50
12	40.00	11.76	245.9	41.0	10.95
15	42.00	12.48	441.8	58.9	14.62
15	60.00	17.65	538.6	71.8	18.17
18	55.00	15.93	795.6	88.4	21.19
18	70.00	20.59	921.2	102.4	24.62
20	65.00	19.08	1,169.5	117.0	27.86
20	75.00	22.06	1,268.8	126.9	30.25
24	80.00	23.32	2,087.2	173.9	42.86
24	100.00	29.41	2,379.6	198.3	48.55

EXAMPLES FOR PRACTICE.

1. Determine the size of a wooden beam which can safely sustain a middle load of 2,000 pounds, if the beam rests on end supports 16 feet apart, and its working strength is 1,000 pounds per square inch. Assume width 6 inches.

Ans. 6×10 inches. ✓

2. What sized steel I-beam is needed to sustain safely a uniform load of 200,000 pounds, if it rests on end supports 10 feet apart, and its working strength is 16,000 pounds per square inch?

Ans. 95-pound 24-inch. ✓

3. What sized steel I-beam is needed to sustain safely the loading of Fig. 10, if its working strength is 16,000 pounds per square inch?

Ans. 14.75-pound 5-inch. ✓

67. Laws of Strength of Beams. The strength of a beam is measured by the bending moment that it can safely withstand; or, since bending and resisting moments are equal, by its safe resisting moment ($SI \div c$). Hence the **safe strength** of a beam varies (1) directly as the working fibre strength of its material, and (2) directly as the section modulus of its cross-section. For beams rectangular in cross-section (as wooden beams), the section modulus is $\frac{1}{6}ba^2$, b and a denoting the breadth and altitude of the rectangle. Hence the strength of such beams varies also directly as the breadth, and as the square of the depth. Thus, doubling the breadth of the section for a rectangular beam doubles the strength, but doubling the depth quadruples the strength.

The **safe load** that a beam can sustain varies directly as its resisting moment, and depends on the way in which the load is distributed and how the beam is supported. Thus, in the first four and last two cases of the table on page 55,

$$\begin{array}{ll}
 M = Pl, & \text{hence } P = SI \div lc, \\
 M = \frac{1}{2} Wl, & \text{“ } W = 2SI \div lc, \\
 M = \frac{1}{4} Pl, & \text{“ } P = 4SI \div lc, \\
 M = \frac{1}{8} Wl, & \text{“ } W = 8SI \div lc, \\
 M = \frac{1}{8} Pl, & \text{“ } P = 8SI \div lc, \\
 M = \frac{1}{12} Wl, & \text{“ } W = 12SI \div lc.
 \end{array}$$

Therefore the safe load in all cases varies inversely with the length; and for the different cases the safe loads are as 1, 2, 4, 8, 8, and 12 respectively.

Example. What is the ratio of the strengths of a plank 2×10 inches when placed edgewise and when placed flatwise on its supports?

When placed edgewise, the section modulus of the plank is $\frac{1}{8} \times 2 \times 10^2 = 33\frac{1}{3}$, and when placed flatwise it is $\frac{1}{8} \times 10 \times 2^2 = 6\frac{2}{3}$; hence its strengths in the two positions are as $33\frac{1}{3}$ to $6\frac{2}{3}$ respectively, or as 5 to 1.

EXAMPLE FOR PRACTICE.

What is the ratio of the safe loads for two beams of wood, one being 10 feet long, 3×12 inches in section, and having its load in the middle; and the other 8 feet long and 2×8 inches in section, with its load uniformly distributed.

Ans. As 28.8 to 21.3

68. Modulus of Rupture. If a beam is loaded to destruction, and the value of the bending moment for the rupture stage is computed and substituted for M in the formula $SI \div c = M$, then the value of S computed from the equation is the **modulus of rupture** for the material of the beam. Many experiments have been performed to ascertain the moduli of rupture for different materials and for different grades of the same material. The following are fair values, all in pounds per square inch:

TABLE D.
Moduli of Rupture.

<i>Timber:</i>			
Spruce.....	4,000—	7,000, average	5,000
Hemlock.....	3,500	7,000, “	4,500
White pine.....	5,500	10,500, “	8,000
Long-leaf pine...	10,000	16,000, “	12,500
Short-leaf pine...	8,000	14,000, “	10,000
Douglas spruce...	4,000	12,000, “	8,000
White oak.....	7,500	18,500, “	13,000
Red oak.....	9,000	15,000, “	11,500
<i>Stone:</i>			
Sandstone.....	400—	1,200,	
Limestone.....	400	1,000.	
Granite.....	800	1,400.	
<i>Cast iron:</i>	One and one-half to two and one-quarter times its ultimate tensile strength.		
<i>Hard steel:</i>	Varies from 100,000 to 150,000		

Wrought iron and structural steels have no modulus of rupture, as specimens of those materials will "bend double," but not break. The modulus of rupture of a material is used principally as a basis for determining its working strength. *The factor of safety of a loaded beam is computed by dividing the modulus of rupture of its material by the greatest unit-fibre stress in the beam.*

69. The Resisting Shear. The shearing stress on a cross-section of a loaded beam is not a uniform stress; that is, it is not uniformly distributed over the section. In fact the intensity or unit-stress is actually zero on the highest and lowest fibres of a cross-section, and is greatest, in such beams as are used in practice, on fibres at the neutral axis. In the following article we explain how to find the maximum value in two cases—cases which are practically important.

70. Second Beam Formula. Let S_s denote the average value of the unit-shearing stress on a cross-section of a loaded beam, and A the area of the cross-section. Then the value of the whole shearing stress on the section is :

$$\text{Resisting shear} = S_s A.$$

Since the resisting shear and the external shear at any section of a beam are equal (see Art. 59),

$$S_s A = V. \quad (7)$$

This is called the "second beam formula" It is used to investigate and to design for shear in beams.

In beams uniform in cross-section, A is constant, and S_s is greatest in the section for which V is greatest. Hence the greatest unit-shearing stress in a loaded beam is at the neutral axis of the section at which the external shear is a maximum. There is a formula for computing this maximum value in any case, but it is not simple, and we give a simpler method for computing the value in the two practically important cases:

1. In wooden beams (rectangular or square in cross-section), the greatest unit-shearing stress in a section is 50 per cent larger than the average value S_s .

2. In I-beams, and in others with a thin vertical web, the greatest unit-shearing stress in a section practically equals S_s , as given by equation 7, if the area of the web is substituted for A .

Examples. 1. What is the greatest value of the unit-shearing stress in a wooden beam 12 feet long and 6×12 inches in cross-section when resting on end supports and sustaining a uniform load of 6,400 pounds? (This is the safe load as determined by working fibre stress; see example 1, Art. 65.)

The maximum external shear equals one-half the load (see Table B, page 53), and comes on the sections near the supports.

Since $A = 6 \times 12 = 72$ square inches;

$$S_s = \frac{3,200}{72} = 44 \text{ pounds per square inch,}$$

and the greatest unit-shearing stress equals

$$\frac{3}{2} S_s = \frac{3}{2} 44 = 66 \text{ pounds per square inch.}$$

Apparently this is very insignificant; but it is not negligible, as is explained in the next article.

2. A steel I-beam resting on end supports 15 feet apart sustains a load of 8,000 pounds 5 feet from one end. The weight of the beam is 375 pounds, and the area of its web section is 3.2 square inches. (This is the beam and load described in examples 2 and 3, Art. 65.) What is the greatest unit-shearing stress?

The maximum external shear occurs near the support where the reaction is the greater, and its value equals that reaction. Calling that reaction R , and taking moments about the other end of the beam, we have

$$R \times 15 - 375 \times 7 \frac{1}{2} - 8,000 \times 10 = 0;$$

$$\text{therefore } 15 R = 80,000 + 2,812.5 = 82,812.5;$$

$$\text{or, } R = 5,520.8 \text{ pounds.}$$

$$\text{Hence } S_s = \frac{5,520.8}{3.2} = 1,725 \text{ pounds per square inch.}$$

EXAMPLES FOR PRACTICE.

1. A wooden beam 10 feet long and 2×10 inches in cross-section sustains a middle load of 1,000 pounds. Neglecting the weight of the beam, compute the value of the greatest unit-shearing stress.

Ans. 37.5 pounds per square inch.

2. Solve the preceding example taking into account the weight of the beam, 60 pounds.

Ans. 40 pounds per square inch. ✓

3. A wooden beam 12 feet long and 4×12 inches in cross-section sustains a load of 3,000 pounds 4 feet from one end. Neglecting the weight of the beam, compute the value of the greatest shearing unit-stress.

Ans. 62.5 pounds per square inch. ✓

71. Horizontal Shear. It can be proved that there is a shearing stress on every horizontal section of a loaded beam. An experimental explanation will have to suffice here. Imagine a pile of six boards of equal length supported so that they do not bend. If the intermediate supports are removed, they will bend and their ends will not be flush but somewhat as represented in Fig. 41. This indicates that the boards slid over each other during the bending, and hence there was a rubbing and a frictional resistance exerted by the boards upon each other. Now, when a solid beam is being bent, there is an exactly similar tendency for the horizontal layers to slide over each other; and, instead of a frictional resistance, there exists shearing stress on all horizontal sections of the beam.

In the pile of boards the amount of slipping is different at different places between any two boards, being greatest near the supports and zero midway between them. Also, in any cross-section the slippage is least between the upper two and lower two boards, and is greatest between the middle two. These facts indicate that the shearing unit-stress on horizontal sections of a solid beam is greatest in the neutral surface at the supports.

It can be proved that at any place in a beam the shearing unit-stresses on a horizontal and on a vertical section are equal.



Fig. 41.

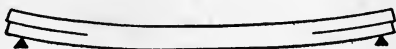

Fig. 42.

It follows that the horizontal shearing unit-stress is greatest at the neutral axis of the section for which the external shear (V) is a maximum. Wood being very weak in shear along the grain, timber beams sometimes fail under shear, the "rupture" being

two horizontal cracks along the neutral surface somewhat as represented in Fig. 42. It is therefore necessary, when dealing with timber beams, to give due attention to their strength as determined by the working strength of the material in shear along the grain.

Example. A wooden beam 3×10 inches in cross-section rests on end supports and sustains a uniform load of 4,000 pounds. Compute the greatest horizontal unit-stress in the beam.

The maximum shear equals one-half the load (see Table B, page 55), or 2,000 pounds. Hence, by equation 7, since $A = 3 \times 10 = 30$ square inches,

$$S_s = \frac{2,000}{30} = 66\frac{2}{3} \text{ pounds per square inch.}$$

This is the average shearing unit-stress on the cross-sections near the supports; and the greatest value equals

$$\frac{3}{2} \times 66\frac{2}{3} = 100 \text{ pounds per square inch.}$$

According to the foregoing, this is also the value of the greatest horizontal shearing unit-stress. (If of white pine, for example, the beam would not be regarded as safe, since the ultimate shearing strength along the grain of selected pine is only about 400 pounds per square inch.)

72. Design of Timber Beams. In any case we may proceed as follows:—(1) Determine the dimensions of the cross-section of the beam from a consideration of the fibre stresses as explained in Art. 66. (2) With dimensions thus determined, compute the value of the greatest shearing unit-stress from the formula,

$$\text{Greatest shearing unit-stress} = \frac{3}{2} V \div ab,$$

where V denotes the maximum external shear in the beam, and b and a the breadth and depth of the cross-section.

If the value of the greatest shearing unit-stress so computed does not exceed the working strength in shear along the grain, then the dimensions are large enough; but if it exceeds that value, then a or b , or both, should be increased until $\frac{3}{2} V \div ab$ is less than the working strength. Because timber beams are very often "season checked" (cracked) along the neutral surface, it is advis-

able to take the working strength of wooden beams, in shear along the grain, quite low. One-twentieth of the working fibre strength has been recommended* for all pine beams.

If the working strength in shear is taken equal to one-twentieth the working fibre strength, then it can be shown that,

1. For a beam on end supports loaded in the middle, the safe load depends on the shearing or fibre strength according as the ratio of length to depth ($l \div a$) is less or greater than 10.

2. For a beam on end supports uniformly loaded, the safe load depends on the shearing or fibre strength according as $l \div a$ is less or greater than 20.

Examples. 1. It is required to design a timber beam to sustain loads as represented in Fig. 11, the working fibre strength being 550 pounds and the working shearing strength 50 pounds per square inch.

The maximum bending moment (see example for practice 3, Art. 43; and example for practice 2, Art. 44) equals practically 7,000 foot-pounds or, $7,000 \times 12 = 84,000$ inch-pounds.

Hence, according to equation 6",

$$\frac{I}{c} = \frac{84,000}{550} = 152.7 \text{ inches}^3.$$

Since for a rectangle

$$\frac{I}{c} = \frac{1}{6} ba^2,$$

$$\frac{1}{6} ba^2 = 152.7, \text{ or } ba^2 = 916.2.$$

Now, if we let $b = 4$, then $a^2 = 229$;

or, $a = 15.1$ (practically 16) inches.

If, again, we let $b = 6$, then $a^2 = 152.7$;

or $a = 12.4$ (practically 14) inches.

Either of these sizes will answer so far as fibre stress is concerned, but there is more "timber" in the second.

The maximum external shear in the beam equals 1,556 pounds, neglecting the weight of the beam (see example 3, Art. 37; and example 2, Art. 38). Therefore, for a 4×16 -inch beam,

* See "Materials of Construction."—JOHNSON. Page 55.

$$\begin{aligned} \text{Greatest shearing unit-stress} &= \frac{3}{2} \times \frac{1,556}{4 \times 16} \\ &= 36.5 \text{ pounds per square inch;} \end{aligned}$$

and for a 6×14 -inch beam, it equals

$$\frac{3}{2} \times \frac{1,556}{6 \times 14} = 27.7 \text{ pounds per square inch.}$$

Since these values are less than the working strength in shear, either size of beam is safe as regards shear.

If it is desired to allow for weight of beam, one of the sizes should be selected. First, its weight should be computed, then the new reactions, and then the unit-fibre stress may be computed as in Art. 64, and the greatest shearing unit-stress as in the foregoing. If these values are within the working values, then the size is large enough to sustain safely the load and the weight of the beam.

2. What is the safe load for a white pine beam 9 feet long and 2×12 inches in cross-section, if the beam rests on end supports and the load is at the middle of the beam, the working fibre strength being 1,000 pounds and the shearing strength 50 pounds per square inch.

The ratio of the length to the depth is less than 10; hence the safe load depends on the shearing strength of the material. Calling the load P , the maximum external shear (see Table B, page 53) equals $\frac{1}{2} P$, and the formula for greatest shearing unit stress becomes

$$50 = \frac{3}{2} \times \frac{\frac{1}{2} P}{2 \times 12}; \text{ or } P = 1,600 \text{ pounds.}$$

EXAMPLES FOR PRACTICE.

1. What size of wooden beam can safely sustain loads as in Fig. 12, with shearing and fibre working strength equal to 50 and 1,000 pounds per square inch respectively?

Ans. 6×12 inches

2. What is the safe load for a wooden beam 4×14 inches, and 18 feet long, if the beam rests on end supports and the load is uniformly distributed, with working strengths as in example 1?

Ans. 3,730 pounds

73. Kinds of Loads and Beams. We shall now discuss the strength of beams under **longitudinal** forces (acting parallel to the beam) and **transverse loads**. The longitudinal forces are supposed to be applied at the ends of the beams and along the axis* of the beam in each case. We consider only beams resting on end supports.

The transverse forces produce **bending** or **flexure**, and the longitudinal or end forces, if pulls, produce **tension** in the beam; if pushes, they produce **compression**. Hence the cases to be considered may be called "Combined Flexure and Tension" and "Combined Flexure and Compression."

74. Flexure and Tension. Let Fig. 43, *a*, represent a beam subjected to the transverse loads L_1 , L_2 and L_3 , and to two equal end pulls P and P . The reactions R_1 and R_2 are due to the transverse loads and can be computed by the methods of moments just as though there were no end pulls. To find the stresses at any cross-section, we determine those due to the transverse forces (L_1 , L_2 , L_3 , R_1 and R_2) and those due to the longitudinal; then combine these stresses to get the total effect of all the applied forces.

The stress due to the transverse forces consists of a shearing stress and a fibre stress; it will be called the **flexural stress**. The fibre stress is compressive above and tensile below. Let M denote the value of the bending moment at the section considered; c_1 and c_2 the distances from the neutral axis to the highest and the lowest fibre in the section; and S_1 and S_2 the corresponding unit-fibre stresses due to the transverse loads. Then

$$S_1 = \frac{Mc_1}{I}; \text{ and } S_2 = \frac{Mc_2}{I}.$$

The stress due to the end pulls is a simple tension, and it equals P ; this is sometimes called the **direct stress**. Let S_0 denote the unit-tension due to P , and A the area of the cross-section; then

$$S_0 = \frac{P}{A}.$$

Both systems of loads to the left of a section between L_1 and

* NOTE. By "axis of a beam" is meant the line through the centers of gravity of all the cross-sections.

L_2 are represented in Fig. 43, *b*; also the stresses caused by them at that section. Clearly the effect of the end pulls is to increase the tensile stress (on the lower fibres) and to decrease the compressive stress (on the upper fibres) due to the flexure. Let S_c denote the total (resultant) unit-stress on the upper fibre, and S_t that on the lower fibre, due to all the forces acting on the beam. In combining the stresses there are two cases to consider:

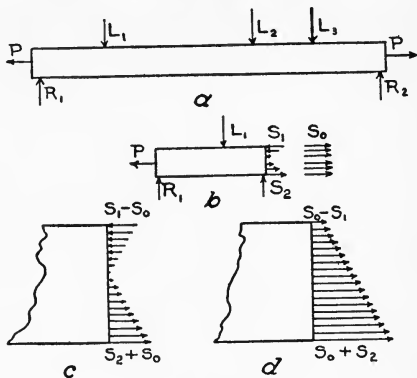

Fig. 43.

(1) The flexural compressive unit-stress on the upper fibre is greater than the direct unit-stress; that is, S_1 is greater than S_o . The resultant stress on the upper fibre is

$$S_c = S_1 - S_o \text{ (compressive);}$$

and that on the lower fibre is

$$S_t = S_2 + S_o \text{ (tensile).}$$

The combined stress is as represented in Fig. 43, *c*, part tensile and part compressive.

(2) The flexural compressive unit-stress is less than the direct unit-stress; that is, S_1 is less than S_o . Then the combined unit-stress on the upper fibre is

$$S_c = S_o - S_1 \text{ (tensile);}$$

and that on the lower fibre is

$$S_t = S_2 + S_o \text{ (tensile).}$$

The combined stress is represented by Fig. 43, *d*, and is all tensile.

Example. A steel bar 2×6 inches, and 12 feet long, is subjected to end pulls of 45,000 pounds. It is supported at each end, and sustains, as a beam, a uniform load of 6,000 pounds. It is required to compute the combined unit-fibre stresses.

Evidently the dangerous section is at the middle, and $M = \frac{1}{8} Wl$; that is,

$$M = \frac{1}{8} \times 6,000 \times 12 = 9,000 \text{ foot-pounds,}$$

or $9,000 \times 12 = 108,000 \text{ inch-pounds.}$

The bar being placed with the six-inch side vertical,

$$c_1 = c_2 = 3 \text{ inches, and}$$

$$I = \frac{1}{12} \times 2 \times 6^3 = 36 \text{ inches}^4. \quad (\text{See Art. 52.})$$

Hence $S_1 = S_2 = \frac{108,000 \times 3}{36} = 9,000 \text{ pounds per square inch.}$

Since $A = 2 \times 6 = 12 \text{ square inches,}$

$$S_o = \frac{45,000}{12} = 3,750 \text{ pounds per square inch.}$$

The greatest value of the combined compressive stress is

$S_1 - S_o = 9,000 - 3,750 = 5,250 \text{ pounds per square inch,}$
and it occurs on the upper fibres of the middle section. The greatest value of the combined tensile stress is

$S_2 + S_o = 9,000 + 3,750 = 12,750 \text{ pounds per square inch,}$
and it occurs on the lowest fibres of the middle section.

EXAMPLE FOR PRACTICE.

Change the load in the preceding illustration to one of 6,000 pounds placed in the middle, and then solve.

$$\text{Ans. } \begin{cases} S_c = 14,250 \text{ pounds per square inch.} \\ S_t = 21,750 \text{ " " " " " " " "} \end{cases}$$

75. Flexure and Compression. Imagine the arrowheads on P reversed; then Fig. 43, *a*, will represent a beam under combined flexural and compressive stresses. The flexural unit-stresses are computed as in the preceding article. The direct stress is a compression equal to P, and the unit-stress due to P is computed as in the preceding article. Evidently the effect of P is to increase the compressive stress and decrease the tensile stress due to the flexure. In combining, we have two cases as before:

(1) The flexural tensile unit-stress is greater than the direct unit-stress; that is, S_2 is greater than S_o . Then the combined unit-stress on the lower fibre is

$$S_t = S_2 - S_o \text{ (tensile);}$$

and that on the upper fibre is

$$S_c = S_1 + S_o \text{ (compressive).}$$

The combined fibre stress is represented by Fig. 44, *a*, and is part tensile and part compressive.

(2) The flexural unit-stress on the lower fibre is less than the direct unit-stress; that is, S_2 is less than S_o . Then the combined unit-stress on the lower fibre is

$$S_t = S_o - S_2 \text{ (compressive);}$$

and that on the upper fibre is

$$S_c = S_o + S_1 \text{ (compressive).}$$

The combined fibre stress is represented by Fig. 44, *b*, and is all compressive.

Example. A piece of timber 6×6 inches, and 10 feet long, is subjected to end pushes of 9,000 pounds. It is supported in a horizontal position at its ends, and sustains a middle load of 400 pounds. Compute the combined fibre stresses.

Evidently the dangerous section is at the middle, and $M = \frac{1}{4} Pl$; that is,

$$M = \frac{1}{4} \times 400 \times 10 = 1,000 \text{ foot-pounds,}$$

or $1,000 \times 12 = 12,000$ inch-pounds.

Since $c_1 = c_2 = 3$ inches, and

$$I = \frac{1}{12} ba^3 = \frac{1}{12} \times 6 \times 6^3 = 108 \text{ inches}^4,$$

$$S_1 = S_2 = \frac{12,000 \times 3}{108} = 333\frac{1}{3} \text{ pounds per square inch.}$$

Since $A = 6 \times 6 = 36$ square inches,

$$S_o = \frac{9,000}{36} = 250 \text{ pounds per square inch.}$$

Hence the greatest value of the combined compressive stress is

$$S_o + S_1 = 333\frac{1}{3} + 250 = 583\frac{1}{3} \text{ pounds per square inch.}$$

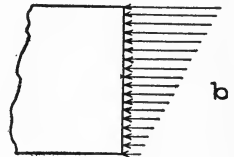
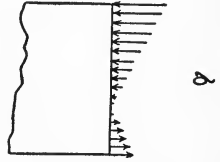

Fig. 44.

It occurs on the upper fibres of the middle section. The greatest value of the combined tensile stress is

$$S_2 - S_0 = 333\frac{1}{3} - 250 = 83\frac{1}{3} \text{ pounds per square inch.}$$

It occurs on the lowest fibres of the middle section.

EXAMPLE FOR PRACTICE.

Change the load of the preceding illustration to a uniform load and solve.

$$\text{Ans. } \begin{cases} S_c = 417 \text{ pounds per square inch.} \\ S_t = 83 \text{ " " " " (compression).} \end{cases}$$

76. Combined Flexural and Direct Stress by More Exact Formulas. The results in the preceding articles are only approxi-

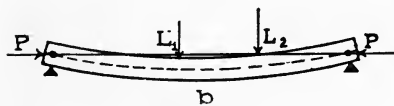
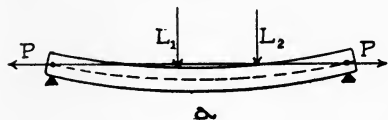

Fig. 45.

mately correct. Imagine the beam represented in Fig. 45, *a*, to be first loaded with the transverse loads alone. They cause the beam to bend more or less, and produce certain flexural stresses at each section of the beam. Now, if end pulls are applied they tend to straighten

the beam and hence diminish the flexural stresses. This effect of the end pulls was omitted in the discussion of Art. 74, and the results there given are therefore only approximate, the value of the greatest combined fibre unit-stress (S_t) being too large. On the other hand, if the end forces are pushes, they increase the bending, and therefore increase the flexural fibre stresses already caused by the transverse forces (see Fig. 45, *b*). The results indicated in Art. 75 must therefore in this case also be regarded as only approximate, the value of the greatest unit-fibre stress (S_c) being too small.

For beams loaded in the middle or with a uniform load, the following formulas, which take into account the flexural effect of the end forces, may be used:

M denotes bending moment at the middle section of the beam;

I denotes the moment of inertia of the middle section with respect to the neutral axis;

S_1 , S_2 , c_1 and c_2 have the same meanings as in Arts. 74 and 75, but refer always to the middle section;

l denotes length of the beam;

E is a number depending on the stiffness of the material, the average values of which are, for timber, 1,500,000; and for structural steel 30,000,000.*

$$S_1 = \frac{Mc_1}{I \pm \frac{Pl^2}{10E}}, \text{ and } S_2 = \frac{Mc_2}{I \pm \frac{Pl^2}{10E}}. \quad (8)$$

The plus sign is to be used when the end forces P are pulls, and the minus sign when they are pushes.

It must be remembered that S_1 and S_2 are flexural unit-stresses. The combination of these and the direct unit-stress is made exactly as in articles 74 and 75.

Examples. 1. It is required to apply the formulas of this article to the example of article 74.

As explained in the example referred to, $M = 108,000$ inch-pounds; $c_1 = c_2 = 3$ inches; and $I = 36$ inches⁴. Now, since $l = 12$ feet = 144 inches,

$$S_1 = S_2 = \frac{108,000 \times 3}{36 + \frac{45,000 \times 144^2}{10 \times 30,000,000}} = \frac{324,000}{36 + 3.11} = 8,284 \text{ pounds}$$

per square inch, as compared with 9,000 pounds per square inch, the result reached by the use of the approximate formula.

As before, $S_o = 3,750$ pounds per square inch; hence

$$S_c = 8,284 - 3,750 = 4,534 \text{ pounds per square inch;}$$

$$\text{and } S_t = 8,284 + 3,750 = 12,034 \text{ " " " "}$$

2. It is required to apply the formulas of this article to the example of article 75.

As explained in that example,

$$M = 12,000 \text{ inch-pounds;}$$

$$c_1 = c_2 = 3 \text{ inches, and } I = 108 \text{ inches}^4.$$

Now, since $l = 120$ inches,

$$S_1 = S_2 = \frac{12,000 \times 3}{108 - \frac{9,000 \times 120^2}{10 \times 1,500,000}} = \frac{36,000}{108 - 8.64} = 362 \text{ pounds}$$

* NOTE. This quantity "E" is more fully explained in Article 95.

per square inch, as compared with $333\frac{1}{3}$ pounds per square inch, the result reached by use of the approximate method.

As before, $S_o = 250$ pounds per square inch; hence

$$S_c = 362 + 250 = 612 \text{ pounds per square inch; and}$$

$$S_t = 362 - 250 = 112 \quad \text{“} \quad \text{“} \quad \text{“} \quad \text{“} \quad \text{“}$$

EXAMPLES FOR PRACTICE.

1. Solve the example for practice of Art. 74 by the formulas of this article.

$$\text{Ans. } \left\{ \begin{array}{l} S_c = 12,820 \text{ pounds per square inch.} \\ S_t = 20,320 \quad \text{“} \quad \text{“} \quad \text{“} \quad \text{“} \end{array} \right.$$

2. Solve the example for practice of Art. 75 by the formulas of this article.

$$\text{Ans. } \left\{ \begin{array}{l} S_c = 430 \text{ pounds per square inch.} \\ S_t = 70 \quad \text{“} \quad \text{“} \quad \text{“} \quad \text{“} \quad (\text{compression}). \end{array} \right.$$

STRENGTH OF COLUMNS.

A stick of timber, a bar of iron, etc., when used to sustain end loads which act lengthwise of the pieces, are called **columns**, **posts**, or **struts** if they are so long that they would bend before breaking. When they are so short that they would not bend before breaking, they are called **short blocks**, and their compressive strengths are computed by means of equation 1. The strengths of columns cannot, however, be so simply determined, and we now proceed to explain the method of computing them.

77. End Conditions. The strength of a column depends in part on the way in which its ends bear, or are joined to other parts of a structure, that is, on its “end conditions.” There are practically but three kinds of end conditions, namely:

1. “Hinge” or “pin” ends,
2. “Flat” or “square” ends, and
3. “Fixed” ends.

(1) When a column is fastened to its support at one end by means of a pin about which the column could rotate if the other end were free, it is said to be “hinged” or “pinned” at the former end. Bridge posts or columns are often hinged at the ends.

(2) A column either end of which is flat and perpendicular to its axis and bears on other parts of the structure at that surface, is said to be “flat” or “square” at that end.

(3) Columns are sometimes riveted near their ends directly to other parts of the structure and do not bear directly on their ends; such are called "fixed ended." A column which bears on its flat ends is often fastened near the ends to other parts of the structure, and such an end is also said to be "fixed." The fixing of an end of a column stiffens and therefore strengthens it more or less, but the strength of a column with fixed ends is computed as though its ends were flat. Accordingly we have, so far as strength is concerned, the following classes of columns:

78. Classes of Columns. (1) Both ends hinged or pinned; (2) one end hinged and one flat; (3) both ends flat.

Other things being the same, columns of these three classes are unequal in strength. Columns of the first class are the weakest, and those of the third class are the strongest.

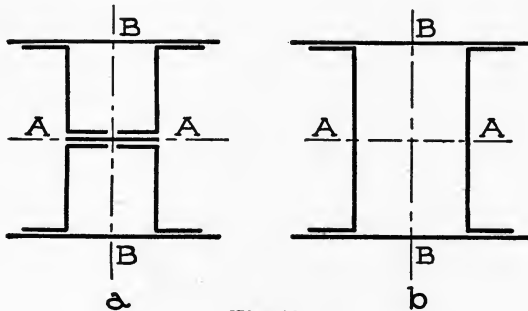

Fig. 46.

79. Cross-sections of Columns. Wooden columns are usually solid, square, rectangular, or round in section; but sometimes they are "built up" hollow. Cast-iron columns are practically always made hollow, and rectangular or round in section. Steel columns are made of single rolled shapes—angles, zees, channels, etc.; but the larger ones are usually "built up" of several shapes. Fig. 46, *a*, for example, represents a cross-section of a "Z-bar" column; and Fig. 46, *b*, that of a "channel" column.

80. Radius of Gyration. There is a quantity appearing in almost all formulas for the strength of columns, which is called "radius of gyration." It depends on the form and extent of the cross-section of the column, and may be defined as follows:

The radius of gyration of any plane figure (as the section of a column) with respect to any line, is such a length that the square of this length multiplied by the area of the figure equals the moment of inertia of the figure with respect to the given line.

Thus, if A denotes the area of a figure; I , its moment of inertia with respect to some line; and r , the radius of gyration with respect to that line; then

$$r^2 A = I; \text{ or } r = \sqrt{I \div A}. \quad (9)$$

In the column formulas, the radius of gyration always refers to an axis through the center of gravity of the cross-section, and usually to that axis with respect to which the radius of gyration (and moment of inertia) is least. (For an exception, see example 3, Art. 83.) Hence the radius of gyration in this connection is often called for brevity the "least radius of gyration," or simply the "least radius."

Examples. 1. Show that the value of the radius of gyration given for the square in Table A, page 52, is correct.

The moment of inertia of the square with respect to the axis is $\frac{1}{12}a^4$. Since $A = a^2$, then, by formula 9 above,

$$r = \sqrt{\frac{1}{12}a^4 \div a^2} = \sqrt{\frac{1}{12}a^2} = a\sqrt{\frac{1}{12}}.$$

2. Prove that the value of the radius of gyration given for the hollow square in Table A, page 54, is correct.

The value of the moment of inertia of the square with respect to the axis is $\frac{1}{12}(a^4 - a_1^4)$. Since $A = a^2 - a_1^2$,

$$r = \sqrt{\frac{\frac{1}{12}(a^4 - a_1^4)}{a^2 - a_1^2}} = \sqrt{\frac{1}{12}(a^2 + a_1^2)}.$$

EXAMPLE FOR PRACTICE.

Prove that the values of the radii of gyration of the other figures given in Table A, page 52, are correct. The axis in each case is indicated by the line through the center of gravity.

81. Radius of Gyration of Built-up Sections. The radius of gyration of a built-up section is computed similarly to that of any other figure. First, we have to compute the moment of inertia of

the section, as explained in Art. 54; and then we use formula 9, as in the examples of the preceding article.

Example. It is required to compute the radius of gyration of the section represented in Fig. 30 (page 52) with respect to the axis AA.

In example 1, Art. 54, it is shown that the moment of inertia of the section with respect to the axis AA is 429 inches⁴. The area of the whole section is

$$2 \times 6.03 + 7 = 19.06;$$

hence the radius of gyration r is

$$r = \sqrt{\frac{429}{19.06}} = 4.74 \text{ inches.}$$

EXAMPLE FOR PRACTICE.

Compute the radii of gyration of the section represented in Fig. 31, *a*, with respect to the axes AA and BB. (See examples for practice 1 and 2, Art. 54.)

$$\text{Ans. } \begin{cases} 2.87 \text{ inches.} \\ 2.09 \text{ "} \end{cases}$$

82. Kinds of Column Loads. When the loads applied to a column are such that their resultant acts through the center of gravity of the top section and along the axis of the column, the column is said to be **centrally loaded**. When the resultant of the loads does not act through the center of gravity of the top section, the column is said to be **eccentrically loaded**. All the following formulas refer to columns centrally loaded.

83. Rankine's Column Formula. When a perfectly straight column is centrally loaded, then, if the column does not bend and if it is homogeneous, the stress on every cross-section is a uniform compression. If P denotes the load and A the area of the cross-section, the value of the unit-compression is $P \div A$.

On account of lack of straightness or lack of uniformity in material, or failure to secure exact central application of the load, the load P has what is known as an "arm" or "leverage" and bends the column more or less. There is therefore in such a column a bending or flexural stress in addition to the direct compressive stress above mentioned; this bending stress is compressive

on the concave side and tensile on the convex. The value of the stress per unit-area (unit-stress) on the fibre at the concave side, according to equation 6, is $Mc \div I$, where M denotes the bending moment at the section (due to the load on the column), c the distance from the neutral axis to the concave side, and I the moment of inertia of the cross-section with respect to the neutral axis. (Notice that this axis is perpendicular to the plane in which the column bends.)

The upper set of arrows (Fig. 47) represents the direct compressive stress; and the second set the bending stress if the load is not excessive, so that the stresses are within the elastic limit of the material. The third set represents the combined stress that actually exists on the cross-section. The greatest combined unit-stress evidently occurs on the fibre at the concave side and where

the deflection of the column is greatest. The stress is compressive, and its value S per unit-area is given by the formula,

$$S = \frac{P}{A} + \frac{Mc}{I}.$$

Now, the bending moment at the place of greatest deflection equals the product of the load P and its arm (that is, the deflection). Calling the deflection d , we have $M = Pd$; and this value of M , substituted in the last equation, gives

$$S = \frac{P}{A} + \frac{Pdc}{I}.$$

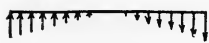
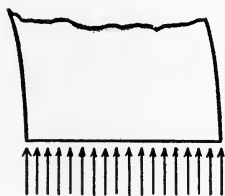

Fig. 47.

Let r denote the radius of gyration of the cross-section with respect to the neutral axis. Then $I = Ar^2$ (see equation 9); and this value, substituted in the last equation, gives

$$S = \frac{P}{A} + \frac{Pdc}{Ar^2} = \frac{P}{A} \left(1 + \frac{dc}{r^2}\right).$$

According to the theory of the stiffness of beams on end supports, deflections vary directly as the square of the length l , and inversely as the distance c from the neutral axis to the remotest fibre of the cross-section. Assuming that the deflections of columns

follow the same laws, we may write $d = k (l^2 \div c)$, where k is some constant depending on the material of the column and on the end conditions. Substituting this value for d in the last equation, we find that

$$\left. \begin{aligned} S &= \frac{P}{A} \left(1 + k \frac{l^2}{r^2} \right); \\ \frac{P}{A} &= \frac{S}{1 + k \frac{l^2}{r^2}}; \\ \text{and} \quad P &= \frac{SA}{1 + k \frac{l^2}{r^2}}. \end{aligned} \right\} \quad (10)$$

Each of these (usually the last) is known as "Rankine's formula."

For *mild-steel* columns a certain large steel company uses $S = 50,000$ pounds per square inch, and the following values of k :

1. Columns with two pin ends, $k = 1 + 18,000.$
2. " " one flat and one pin end, $k = 1 + 24,000.$
3. " " both ends flat, $k = 1 + 36,000.$

With these values of S and k , P of the formula means the **ultimate load**, that is, the load causing failure. The safe load equals P divided by the selected factor of safety—a factor of 4 for steady loads, and 5 for moving loads, being recommended by the company referred to. The same unit is to be used for l and r .

Cast-iron columns are practically always made hollow with comparatively thin walls, and are usually circular or rectangular in cross-section. The following modifications of Rankine's formula are sometimes used:

$$\left. \begin{aligned} \text{For circular sections,} \quad \frac{P}{A} &= \frac{80,000}{1 + \frac{l^2}{800 d^2}} \\ \text{For rectangular sections,} \quad \frac{P}{A} &= \frac{80,000}{1 + \frac{l^2}{1,000 d^2}} \end{aligned} \right\} \quad (10')$$

In these formulas d denotes the outside diameter of the circular sections or the length of the lesser side of the rectangular sections. The same unit is to be used for l and d .

Examples. 1. A 40-pound 10-inch steel I-beam 8 feet long is used as a flat-ended column. Its load being 100,000 pounds, what is its factor of safety?

Obviously the column tends to bend in a plane perpendicular to its web. Hence the radius of gyration to be used is the one

with respect to that central axis of the cross-section which is in the web, that is, axis 2 - 2 (see figure accompanying table, page 72). The moment of inertia of the section with respect to that axis, according to the table, is 9.50 inches⁴; and since the area of the section is 11.76 square inches,

$$r^2 = \frac{9.50}{11.76} = 0.808.$$

Now, $l = 8$ feet = 96 inches; and since $k = 1 \div 36,000$, and $S = 50,000$, the breaking load for this column, according to Rankine's formula, is

$$P = \frac{50,000 \times 11.76}{96^2} = 446,790 \text{ pounds.}$$

$$1 + \frac{36,000 \times 0.808}{96^2}$$

Since the factor of safety equals the ratio of the breaking load to the actual load on the column, the factor of safety in this case is

$$\frac{446,790}{100,000} = 4.5 \text{ (approx.).}$$

2. What is the safe load for a cast-iron column 10 feet long with square ends and a hollow rectangular section, the outside dimensions being 5×8 inches; the inner, 4×7 inches; and the factor of safety, 6?

In this case $l = 10$ feet = 120 inches; $A = 5 \times 8 - 4 \times 7 = 12$ square inches; and $d = 5$ inches. Hence, according to formula 10', for rectangular sections, the breaking load is

$$P = \frac{80,000 \times 12}{120^2} = 610,000 \text{ pounds.}$$

$$1 + \frac{1,000 \times 5^2}{120^2}$$

Since the safe load equals the breaking load divided by the factor of safety, in this case the safe load equals

$$\frac{610,000}{6} = 101,700 \text{ pounds.}$$

3. A channel column (see Fig. 46, *b*) is pin-ended, the pins being perpendicular to the webs of the channel (represented by AA in the figure), and its length is 16 feet (distance between axes

of the pins). If the sectional area is 23.5 square inches, and the moment of inertia with respect to AA is 386 inches⁴ and with respect to BB 214 inches⁴, what is the safe load with a factor of safety of 4?

The column is liable to bend in one of two ways, namely, in the plane perpendicular to the axes of the two pins, or in the plane containing those axes.

(1) For bending in the first plane, the strength of the column is to be computed from the formula for a pin-ended column. Hence, for this case, $r^2 = 386 \div 23.5 = 16$; and the breaking load is

$$P = \frac{50,000 \times 23.5}{1 + \frac{(16 \times 12)^2}{18,000 \times 16}} = 1,041,600 \text{ pounds.}$$

The safe load for this case equals $\frac{1,041,600}{4} = 260,400$ pounds.

(2) If the supports of the pins are rigid, then the pins stiffen the column as to bending in the plane of their axes, and the strength of the column for bending in that plane should be computed from the formula for the strength of columns with flat ends. Hence, $r^2 = 214 \div 23.5 = 9.11$, and the breaking load is

$$P = \frac{50,000 \times 23.5}{1 + \frac{(16 \times 12)^2}{36,000 \times 9.11}} = 1,056,000 \text{ pounds.}$$

The safe load for this case equals $\frac{1,056,000}{4} = 264,000$ pounds.

EXAMPLES FOR PRACTICE.

1. A 40-pound 12-inch steel I-beam 10 feet long is used as a column with flat ends sustaining a load of 100,000 pounds. What is its factor of safety?

Ans. 4.1

2. A cast-iron column 15 feet long sustains a load of 150,000 pounds. Its section being a hollow circle, 9 inches outside and 7 inches inside diameter, what is the factor of safety?

Ans. 8.9

3. A steel Z-bar column (see Fig. 46, a) is 24 feet long and has square ends; the least radius of gyration of its cross-section is

3.1 inches; and the area of the cross-section is 24.5 square inches. What is the safe load for the column with a factor of safety of 4?

Ans. 247,000 pounds.

4. A cast-iron column 13 feet long has a hollow circular cross-section 7 inches outside and $5\frac{1}{2}$ inches inside diameter. What is its safe load with a factor of safety of 6?

Ans. 121,142 pounds.

5. Compute the safe load for a 40-pound 12-inch steel I-beam used as a column with flat ends, its length being 17 feet. Use a factor of safety of 5.

Ans. 52,470 pounds.

84. Graphical Representation of Column Formulas. Column (and most other engineering) formulas can be represented graphically. To represent Rankine's formula for flat-ended mild-steel columns,

$$\frac{P}{A} = \frac{50,000}{1 + \frac{(l \div r)^2}{36,000}}$$

we first substitute different values of $l \div r$ in the formula, and solve for $P \div A$. Thus we find, when

$$l \div r = 40, P \div A = 47,900;$$

$$l \div r = 80, P \div A = 42,500;$$

$$l \div r = 120, P \div A = 35,750;$$

etc., etc.

Now, if these values of $l \div r$ be laid off by some scale on a line from O, Fig. 48, and the corresponding values of $P \div A$ be laid

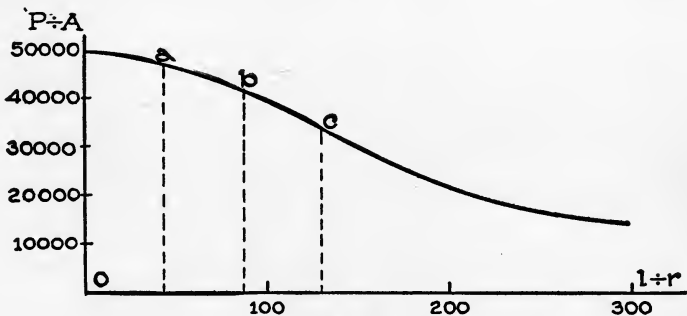

Fig. 48.

off vertically from the points on the line, we get a series of points as a , b , c , etc.; and a smooth curve through the points a , b , c ,

etc., represents the formula. Such a curve, besides representing the formula to one's eye, can be used for finding the value of $P \div A$ for any value of $l \div r$; or the value of $l \div r$ for any value of $P \div A$. The use herein made is in explaining other column formulas in succeeding articles.

85. Combination Column Formulas. Many columns have been tested to destruction in order to discover in a practical way the laws relating to the strength of columns of different kinds. The results of such tests can be most satisfactorily represented graphically by plotting a point in a diagram for each test. Thus, suppose that a column whose $l \div r$ was 80 failed under a load of 276,000 pounds, and that the area of its cross-section was 7.12 square inches. This test would be represented by laying off Oa , Fig. 49, equal to 80, according to some scale; and then ab equal to $276,000 \div 7.12$ ($P \div A$), according to some other convenient scale. The point b would then represent the result of this particular test. All the dots in the figure represent the way in which the results of a series of tests appear when plotted.

It will be observed at once that the dots do not fall upon any one curve, as the curve of Rankine's formula. Straight lines and

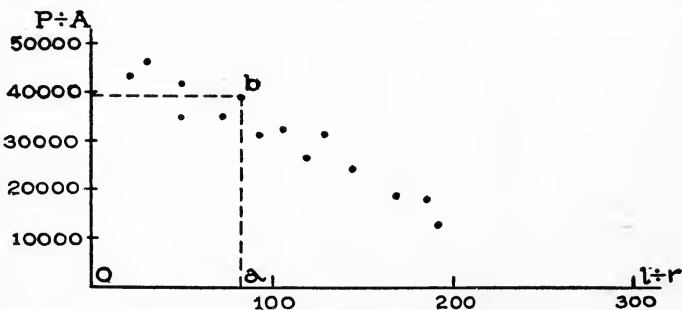

Fig. 49.

curves simpler than the curve of Rankine's formula have been fitted to represent the average positions of the dots as determined by actual tests, and the formulas corresponding to such lines have been deduced as column formulas. These are explained in the following articles.

86. Straight-Line and Euler Formulas. It occurred to Mr. T. H. Johnson that most of the dots corresponding to ordinary

lengths of columns agree with a straight line just as well as with a curve. He therefore, in 1886, made a number of such plats or diagrams as Fig. 49, fitted straight lines to them, and deduced the formula corresponding to each line. These have become known as "straight-line formulas," and their general form is as follows:

$$\frac{P}{A} = S - m \frac{l}{r}, \quad (11)$$

P , A , l , and r having meanings as in Rankine's formula (Art. 83), and S and m being constants whose values according to Johnson are given in Table E below.

For the slender columns, another formula (Euler's, long since deduced) was used by Johnson. Its general form is—

$$\frac{P}{A} = \frac{n}{(l \div r)^2}, \quad (12)$$

n being a constant whose values, according to Johnson, are given in the following table:

TABLE E.

Data for Mild-Steel Columns.

	S	m	Limit ($l \div r$)	n
Hinged ends.....	52,500	220	160	444,000,000
Flat ends.....	52,500	180	195	666,000,000

The numbers in the fourth column of the table mark the point of division between columns of ordinary length and slender columns. For the former kind, the straight-line formula applies; and for the second, Euler's. That is, if the ratio $l \div r$ for a steel column with hinged end, for example, is less than 160, we must use the straight-line formula to compute its safe load, factor of safety, etc.; but if the ratio is greater than 160, we must use Euler's formula.

For *cast-iron columns* with flat ends, $S = 34,000$, and $m = 88$; and since they should never be used "slender," there is no use of Euler's formula for cast-iron columns.

The line AB, Fig. 50, represents Johnson's straight-line formula; and BC, Euler's formula. It will be noticed that the two lines are tangent; the point of tangency corresponds to the "limiting value" $l \div r$, as indicated in the table.

Examples. 1. A 40-pound 10-inch steel I-beam column 8

feet long sustains a load of 100,000 pounds, and the ends are flat. Compute its factor of safety according to the methods of this article.

The first thing to do is to compute the ratio $l \div r$ for the column, to ascertain whether the straight-line formula or Euler's

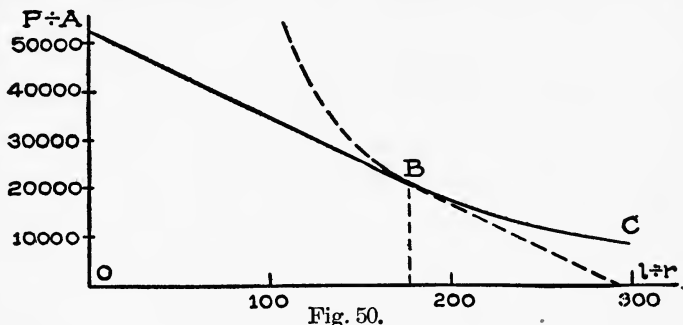

formula should be used. From Table C, on page 70, we find that the moment of inertia of the column about the neutral axis of its cross-section is 9.50 inches⁴, and the area of the section is 11.76 square inches. Hence

$$r^2 = \frac{9.50}{11.76} = 0.81; \text{ or } r = 0.9 \text{ inch.}$$

Since $l = 8 \text{ feet} = 96 \text{ inches}$,

$$\frac{l}{r} = \frac{96}{0.9} = 106\frac{2}{3}$$

This value of $l \div r$ is less than the limiting value (195) indicated by the table for steel columns with flat ends (Table E, p. 97), and we should therefore use the straight-line formula; hence

$$\frac{P}{11.76} = 52,500 - 180 \times 106\frac{2}{3};$$

$$\text{or, } P = 11.76 \left(52,500 - 180 \times 106\frac{2}{3} \right) = 391,600 \text{ pounds.}$$

This is the breaking load for the column according to the straight-line formula; hence the factor of safety is

$$\frac{391,600}{100,000} = 3.9$$

2. Suppose that the length of the column described in the preceding example were 16 feet. What would its factor of safety be?

Since $l = 16$ feet $= 192$ inches; and, as before, $r = 0.9$ inch, $l \div r = 213\frac{1}{3}$. This value is greater than the limiting value (195) indicated by Table E (p. 97) for flat-ended steel columns; hence Euler's formula is to be used. Thus

$$\frac{P}{11.76} = \frac{666,000,000}{(213\frac{1}{3})^2};$$

or,
$$P = \frac{11.76 \times 666,000,000}{(213\frac{1}{3})^2} = 172,100 \text{ pounds.}$$

This is the breaking load; hence the factor of safety is

$$\frac{172,100}{100,000} = 1.7$$

3. What is the safe load for a cast-iron column 10 feet long with square ends and hollow rectangular section, the outside dimensions being 5×8 inches and the inside 4×7 inches, with a factor of safety of 6?

Substituting in the formula for the radius of gyration given in Table A, page 52, we get

$$r = \sqrt{\frac{8 \times 5^3 - 7 \times 4^3}{12(8 \times 5 - 7 \times 4)}} = 1.96 \text{ inches.}$$

Since $l = 10$ feet $= 120$ inches,

$$\frac{l}{r} = \frac{120}{1.96} = 61.22$$

According to the straight-line formula for cast iron, A being equal to 12 square inches,

$$\frac{P}{12} = 34,000 - 88 \times 61.22;$$

or,
$$P = 12(34,000 - 88 \times 61.22) = 343,360 \text{ pounds.}$$

This being the breaking load, the safe load is

$$\frac{343,360}{6} = 57,227 \text{ pounds.}$$

EXAMPLES FOR PRACTICE.

1. A 40-pound 12-inch steel I-beam 10 feet long is used as a flat-ended column. Its load being 100,000 pounds, compute the factor of safety by the formulas of this article.

Ans. 3.5

2. A cast-iron column 15 feet long sustains a load of 150,000 pounds. Its section being a hollow circle of 9 inches outside and 7 inches inside diameter, compute the factor of safety by the straight-line formula.

Ans. 4.8

3. A steel Z-bar column (see Fig. 46, *a*) is 24 feet long and has square ends; the least radius of gyration of its cross-section is 3.1 inches; and the area of the cross-section is 24.5 square inches. Compute the safe load for the column by the formulas of this article, using a factor of safety of 4.

Ans. 219,000 pounds.

4. A hollow cast-iron column 13 feet long has a circular cross-section, and is 7 inches outside and $5\frac{1}{2}$ inches inside in diameter. Compute its safe load by the formulas of this article, using a factor of safety of 6.

Ans. 68,500 pounds

5. Compute by the methods of this article the safe load for a 40-pound 12-inch steel I-beam used as a column with flat ends, if the length is 17 feet and the factor of safety 5.

Ans. 35,100 pounds.

87. Parabola-Euler Formulas. As better fitting the results of tests of the strength of columns of "ordinary lengths," Prof. J. B. Johnson proposed (1892) to use parabolas instead of straight lines. The general form of the "parabola formula" is

$$\frac{P}{A} = S - m\left(\frac{l}{r}\right)^2, \quad (13)$$

P , A , l and r having the same meanings as in Rankine's formula, Art. 83; and S and m denoting constants whose values, according to Professor Johnson, are given in Table F below.

Like the straight-line formula, the parabola formula should not be used for slender columns, but the following (Euler's) is applicable:

$$\frac{P}{A} = \frac{n}{(l \div r)^2} \tag{14}$$

the values of n (Johnson) being given in the following table:

TABLE F.
Data for Mild Steel Columns.

	S	m	Limit ($l \div r$)	n
Hinged ends.....	42,000	0.97	150	456,000,000
Flat ends.....	42,000	0.62	190	712,000,000

The point of division between columns of ordinary length and slender columns is given in the fourth column of the table. That is, if the ratio $l \div r$ for a column with hinged ends, for example, is less than 150, the parabola formula should be used to compute the safe load, factor of safety, etc.; but if the ratio is greater than 150, then Euler's formula should be used.

The line AB, Fig. 51, represents the parabola formula; and the line BC, Euler's formula. The two lines are tangent, and the point of tangency corresponds to the "limiting value" $l \div r$ of the table.

For *wooden columns* square in cross-section, it is convenient to replace r by d , the latter denoting the length of the sides of the square. The formula becomes

$$\frac{P}{A} = S - m \left(\frac{l}{d}\right)^2,$$

S and m for flat-ended columns of various kinds of wood having the following values according to Professor Johnson:

- For White pine, $S=2,500$, $m=0.6$;
- " Short-leaf yellow pine, $S=3,300$, $m=0.7$;
- " Long-leaf yellow pine, $S=4,000$, $m=0.8$;
- " White oak, $S=3,500$, $m=0.8$.

The preceding formula applies to any wooden column whose ratio, $l \div d$, is less than 60, within which limit columns of practice are included.

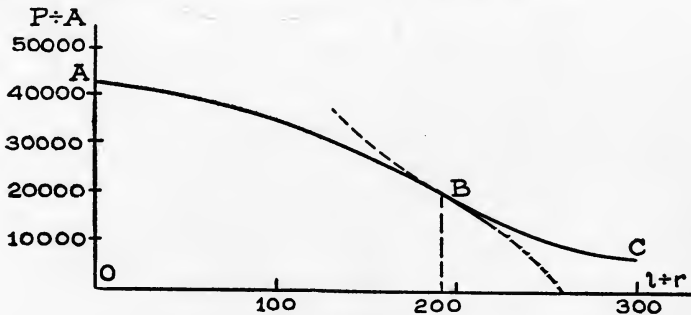

Fig. 51.

Examples. 1. A 40-pound 10-inch steel I-beam column

8 feet long sustains a load of 100,000 pounds, and its ends are flat. Compute its factor of safety according to the methods of this article.

The first thing to do is to compute the ratio $l \div r$ for the column, to ascertain whether the parabola formula or Euler's formula should be used. As shown in example 1 of the preceding article, $l \div r = 106\frac{2}{3}$. This ratio being less than the limiting value, 190, of the table, we should use the parabola formula. Hence, since the area of the cross-section is 11.76 square inches (see Table C, page 70),

$$\frac{P}{11.76} = 42,000 - 0.62 (106\frac{2}{3})^2;$$

or, $P = 11.76 [42,000 - 0.62 (106\frac{2}{3})^2] = 410,970$ pounds.

This is the breaking load according to the parabola formula; hence the factor of safety is

$$\frac{410,970}{100,000} = 4.1$$

2. A white pine column 10×10 inches in cross-section and 18 feet long sustains a load of 40,000 pounds. What is its factor of safety?

The length is 18 feet or 216 inches; hence the ratio $l \div d = 21.6$, and the parabola formula is to be applied.

Now, since $A = 10 \times 10 = 100$ square inches,

$$\frac{P}{100} = 2,500 - 0.6 \times 21.6^2;$$

or, $P = 100 (2,500 - 0.6 \times 21.6^2) = 222,000$ pounds.

This being the breaking load according to the parabola formula, the factor of safety is

$$\frac{222,000}{40,000} = 5.5$$

3. What is the safe load for a long-leaf yellow pine column 12×12 inches square and 30 feet long, the factor of safety being 5?

The length being 30 feet or 360 inches,

$$\frac{l}{d} = \frac{360}{12} = 30;$$

hence the parabola formula should be used. Since $A = 12 \times 12 = 144$ square inches,

$$\frac{P}{144} = 4,000 - 0.8 \times 30^2;$$

or, $P = 144 (4,000 - 0.8 \times 30^2) = 472,320$ pounds.

This being the breaking load according to the parabola formula, the safe load is

$$\frac{472,320}{5} = 94,465 \text{ pounds.}$$

EXAMPLES FOR PRACTICE.

1. A 40-pound 12-inch steel I-beam 10 feet long is used as a flat-ended column. Its load being 100,000 pounds, compute its factor of safety by the formulas of this article.

Ans. 3.8

2. A white oak column 15 feet long sustains a load of 30,000 pounds. Its section being 8×8 inches, compute the factor of safety by the parabola formula.

Ans. 6.6

3. A steel Z-bar column (see Fig. 46, *a*) is 24 feet long and has square ends; the least radius of gyration of its cross-section is 3.1 inches; and the area of its cross-section is 24.5 square inches. Compute the safe load for the column by the formulas of this article, using a factor of safety of 4.

Ans. 224,500 pounds.

4. A short-leaf yellow pine column 14×14 inches in section is 20 feet long. What load can it sustain, with a factor of safety of 6?

Ans. 101,100 pounds.

88. "Broken Straight-Line" Formula. A large steel company computes the strength of its flat-ended steel columns by two formulas represented by two straight lines AB and BC, Fig. 52. The formulas are

$$\frac{P}{A} = 48,000,$$

and $\frac{P}{A} = 68,400 - 228 \frac{l}{r},$

P , A , l , and r having the same meanings as in Art. 83.

The point B corresponds very nearly to the ratio $l \div r = 90$. Hence, for columns for which the ratio $l \div r$ is less than 90, the first formula applies; and for columns for which the ratio is greater than 90, the second one applies. The point C corresponds to the ratio $l \div r = 200$, and the second formula does not apply to a column for which $l \div r$ is greater than that limit.

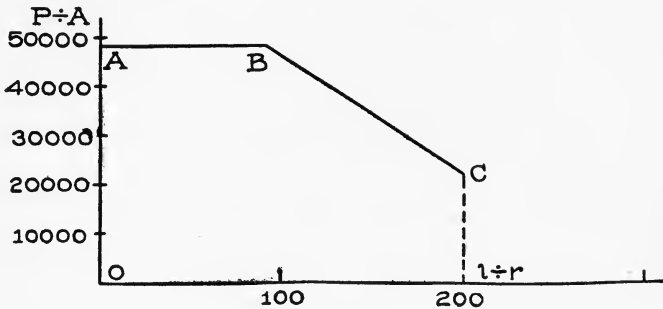

Fig. 52.

The ratio $l \div r$ for steel columns of practice rarely exceeds 150, and is usually less than 100.

Fig. 53 is a combination of Figs. 49, 50, 51 and 52, and represents graphically a comparison of the Rankine, straight-line, Euler, parabola-Euler, and broken straight-line formulas for flat-ended mild-steel columns. It well illustrates the fact that our knowledge of the strength of columns is not so exact as that, for example, of the strength of beams.

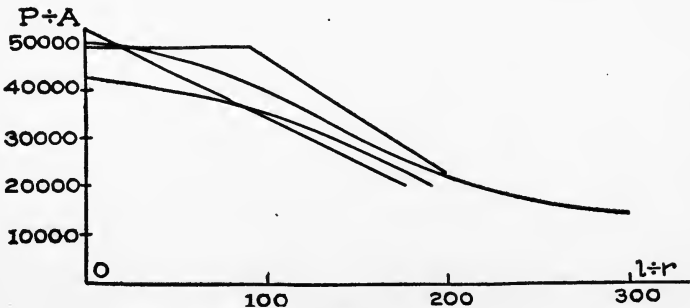

Fig. 53.

89. Design of Columns. All the preceding examples relating to columns were on either (1) computing the factor of safety

of a given loaded column, or (2) computing the safe load for a given column. A more important problem is to design a column to sustain a given load under given conditions. A complete discussion of this problem is given in a later paper on design. We show here merely how to compute the *dimensions* of the cross-section of the column after the *form* of the cross-section has been decided upon.

In only a few cases can the dimensions be computed directly (see example 1 following), but usually, when a column formula is applied to a certain case, there will be two unknown quantities in it, A and r or d . Such cases can best be solved by trial (see examples 2 and 3 below).

Example. 1. What is the proper size of white pine column to sustain a load of 80,000 pounds with a factor of safety of 5, when the length of the column is 22 feet?

We use the parabola formula (equation 13). Since the safe load is 80,000 pounds and the factor of safety is 5, the breaking load P is

$$80,000 \times 5 = 400,000 \text{ pounds.}$$

The unknown side of the (square) cross-section being denoted by d , the area A is d^2 . Hence, substituting in the formula, since $l = 22 \text{ feet} = 264 \text{ inches}$, we have

$$\frac{400,000}{d^2} = 2,500 - 0.6 \frac{264^2}{d^2}.$$

Multiplying both sides by d^2 gives

$$400,000 = 2,500 d^2 - 0.6 \times 264^2,$$

or
$$2,500 d^2 = 400,000 + 0.6 \times 264^2 = 441,817.6.$$

Hence
$$d^2 = 176.73, \text{ or } d = 13.3 \text{ inches.}$$

2. What size of cast-iron column is needed to sustain a load of 100,000 pounds with a factor of safety of 10, the length of the column being 14 feet?

We shall suppose that it has been decided to make the cross-section circular, and shall compute by Rankine's formula modified for cast-iron columns (equation 10'). The breaking load for the column would be

$$100,000 \times 10 = 1,000,000 \text{ pounds.}$$

The length is 14 feet or 168 inches; hence the formula becomes

$$\frac{1,000,000}{A} = \frac{80,000}{1 + \frac{168^2}{800d^2}};$$

or, reducing by dividing both sides of the equation by 10,000, and then clearing of fractions, we have

$$100 \left[1 + \frac{168^2}{800d^2} \right] = 8A.$$

There are two unknown quantities in this equation, d and A , and we cannot solve directly for them. Probably the best way to proceed is to assume or guess at a practical value of d , then solve for A , and finally compute the thickness or inner diameter. Thus, let us try d equal to 7 inches, first solving the equation for A as far as possible. Dividing both sides by 8 we have

$$A = \frac{100}{8} \left[1 + \frac{168^2}{800d^2} \right],$$

and, combining,

$$A = 12.5 + \frac{441}{d^2}.$$

Now, substituting 7 for d , we have

$$A = 12.5 + \frac{441}{49} = 21.5 \text{ square inches.}$$

The area of a hollow circle whose outer and inner diameters are d and d_1 respectively, is $0.7854 (d^2 - d_1^2)$. Hence, to find the inner diameter of the column, we substitute 7 for d in the last expression, equate it to the value of A just found, and solve for d_1 . Thus,

$$0.7854 (49 - d_1^2) = 21.5.$$

hence

$$49 - d_1^2 = \frac{21.5}{0.7854} = 27.37;$$

and $d_1^2 = 49 - 27.37 = 21.63$ or $d_1 = 4.65$.

This value of d makes the thickness equal to

$$\frac{1}{2} (7 - 4.65) = 1.175 \text{ inches,}$$

which is safe. It might be advisable in an actual case to try d equal to 8 repeating the computation.*

EXAMPLE FOR PRACTICE.

1. What size of white oak column is needed to sustain a load of 45,000 pounds with a factor of safety of 6, the length of the column being 12 feet.

Ans. $d = 8\frac{1}{2}$, practically a 10×10 -inch section

STRENGTH OF SHAFTS.

A **shaft** is a part of a machine or system of machines, and is used to transmit power by virtue of its torsional strength, or resistance to twisting. Shafts are almost always made of metal and are usually circular in cross-section, being sometimes made hollow.

90. Twisting Moment. Let AF, Fig. 54, represent a shaft with four pulleys on it. Suppose that D is the driving pulley and that B, C and E are pulleys from which power is taken off to drive machines. The portions of the shafts between the pulleys

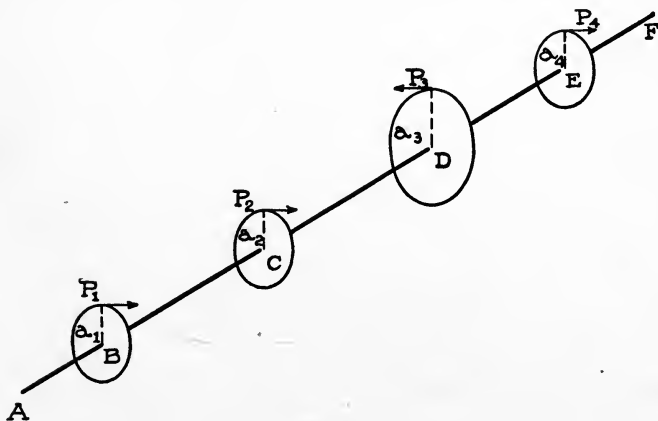

Fig. 54.

are twisted when it is transmitting power; and by the twisting moment at any cross-section of the shaft is meant the algebraic sum of the moments of all the forces acting on the shaft on either

*NOTE. The structural steel handbooks contain extensive tables by means of which the design of columns of steel or cast iron is much facilitated. The difficulties encountered in the use of formulæ are well illustrated in this example.

side of the section, the moments being taken with respect to the axis of the shaft. Thus, if the forces acting on the shaft (at the pulleys) are P_1 , P_2 , P_3 , and P_4 as shown, and if the arms of the forces or radii of the pulleys are a_1 , a_2 , a_3 , and a_4 respectively, then the twisting moment at any section in

$$\begin{aligned} \text{BC is } & P_1 a_1, \\ \text{CD is } & P_1 a_1 + P_2 a_2, \\ \text{DE is } & P_1 a_1 + P_2 a_2 - P_3 a_3. \end{aligned}$$

Like bending moments, twisting moments are usually expressed in inch-pounds.

Example. Let $a_1 = a_2 = a_4 = 15$ inches, $a_3 = 30$ inches, $P_1 = 400$ pounds, $P_2 = 500$ pounds, $P_3 = 750$ pounds, and $P_4 = 600$ pounds.* What is the value of the greatest twisting moment in the shaft?

At any section between the first and second pulleys, the twisting moment is

$$400 \times 15 = 6,000 \text{ inch-pounds;}$$

at any section between the second and third it is

$$400 \times 15 + 500 \times 15 = 13,500 \text{ inch-pounds; and}$$

at any section between the third and fourth it is

$$400 \times 15 + 500 \times 15 - 750 \times 30 = -9,000 \text{ inch-pounds.}$$

Hence the greatest value is 13,500 inch-pounds.

91. Torsional Stress. The stresses in a twisted shaft are called "torsional" stresses. The torsional stress on a cross-section of a shaft is a shearing stress, as in the case illustrated by Fig. 55, which represents a flange coupling in a shaft. Were it not for the bolts, one flange would slip over the other when either part of the shaft is turned; but the bolts prevent the slipping. Obviously there is a tendency to shear the bolts off unless they are screwed up very tight; that is, the material of the bolts is subjected to shearing stress.

Just so, at any section of the solid shaft there is a tendency for one part to slip past the other, and to prevent the slipping or

* Note. These numbers were so chosen that the moment of P (driving moment) equals the sum of the moments of the other forces. This is always the case in a shaft rotating at constant speed; that is, the power given the shaft equals the power taken off.

shearing of the shaft, there arise shearing stresses at all parts of the cross-section. The shearing stress on the cross-section of a shaft is not a uniform stress, its value per unit-area being zero at the center of the section, and increasing toward the circumference. In circular sections, solid or hollow, the shearing stress per unit-area (unit-stress) varies directly as the distance from the center of the section, provided the elastic limit is not exceeded. Thus, if the shearing unit-stress at the circumference of a section is

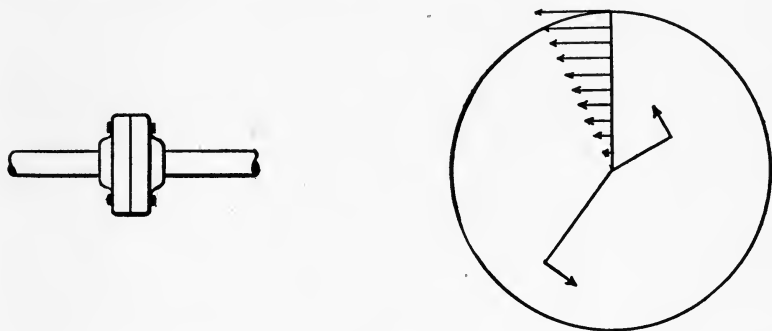

Fig. 55.

1,000 pounds per square inch, and the diameter of the shaft is 2 inches, then, at $\frac{1}{2}$ inch from the center, the unit-stress is 500 pounds per square inch; and at $\frac{1}{4}$ inch from the center it is 250 pounds per square inch. In Fig. 55 the arrows indicate the values and the directions of the shearing stresses on very small portions of the cross-section of a shaft there represented.

92. Resisting Moment. By “resisting moment” at a section of a shaft is meant the sum of the moments of the shearing stresses on the cross-section about the axis of the shaft.

Let S_s denote the value of the shearing stress per unit-area (unit-stress) at the outer points of a section of a shaft; d the diameter of the section (outside diameter if the shaft is hollow); and d_1 the inside diameter. Then it can be shown that the resisting moment is:

For a solid section, $0.1963 S_s d^3$;

For a hollow section, $\frac{0.1963 S_s (d^4 - d_1^4)}{d}$.

93. Formula for the Strength of a Shaft. As in the case

of beams, the resisting moment equals the twisting moment at any section. If T be used to denote twisting moment, then we have the formulas:

$$\left. \begin{array}{l} \text{For solid circular shafts, } 0.1963 S_s d^3 = T; \\ \text{For hollow circular shafts, } \frac{0.1963 S_s (d^4 - d_1^4)}{d} = T. \end{array} \right\} (15)$$

In any portion of a shaft of constant diameter, the unit-shearing stress S_s is greatest where the twisting moment is greatest. Hence, to compute the greatest unit-shearing stress in a shaft, we first determine the value of the greatest twisting moment, substitute its value in the first or second equation above, as the case may be, and solve for S_s . It is customary to express T in inch-pounds and the diameter in inches, S_s then being in pounds per square inch.

Examples. 1. Compute the value of the greatest shearing unit-stress in the portion of the shaft between the first and second pulleys represented in Fig. 54, assuming values of the forces and pulley radii as given in the example of article 90. Suppose also that the shaft is solid, its diameter being 2 inches.

The twisting moment T at any section of the portion between the first and second pulleys is 6,000 inch-pounds, as shown in the example referred to. Hence, substituting in the first of the two formulas 15 above, we have

$$0.1963 S_s \times 2^3 = 6,000;$$

$$\text{or, } S_s = \frac{6,000}{0.1963 \times 8} = 3,820 \text{ pounds per square inch.}$$

This is the value of the unit-stress at the outside portions of all sections between the first and second pulleys.

2. A hollow shaft is circular in cross-section, and its outer and inner diameters are 16 and 8 inches respectively. If the working strength of the material in shear is 10,000 pounds per square inch, what twisting moment can the shaft safely sustain?

The problem requires that we merely substitute the values of S_s , d , and d_1 in the second of the above formulas 15, and solve for T . Thus,

$$T = \frac{0.1963 \times 10,000 (16^4 - 8^4)}{16} = 7,537,920 \text{ inch-pounds.}$$

EXAMPLES FOR PRACTICE.

1. Compute the greatest value of the shearing unit-stress in the shaft represented in Fig. 54, using the values of the forces and pulley radii given in the example of article 90, the diameter of the shaft being 2 inches.

Ans. 8,595 pounds per square inch

2. A solid shaft is circular in cross-section and is 9.6 inches in diameter. If the working strength of the material in shear is 10,000 pounds per square inch, how large a twisting moment can the shaft safely sustain? (The area of the cross-section is practically the same as that of the hollow shaft of example 2 preceding.)

Ans. 1,736,736 inch-pounds.

94. Formula for the Power Which a Shaft Can Transmit.

The power that a shaft can safely transmit depends on the shearing working strength of the material of the shaft, on the size of the cross-section, and on the speed at which the shaft rotates.

Let H denote the amount of horse-power; S_s the shearing working strength in pounds per square inch; d the diameter (outside diameter if the shaft is hollow) in inches; d_1 the inside diameter in inches if the shaft is hollow; and n the number of revolutions of the shaft per minute. Then the relation between power transmitted, unit-stress, etc., is:

$$\left. \begin{array}{l} \text{For solid shafts, } H = \frac{S_s d^3 n}{321,000}; \\ \text{For hollow shafts, } H = \frac{S_s (d^4 - d_1^4) n}{321,000 d}. \end{array} \right\} \quad (16)$$

Examples. 1. What horse-power can a hollow shaft 16 inches and 8 inches in diameter safely transmit at 50 revolutions per minute, if the shearing working strength of the material is 10,000 pounds per square inch?

We have merely to substitute in the second of the two formulas 16 above, and reduce. Thus,

$$H = \frac{10,000 (16^4 - 8^4) 50}{321,000 \times 16} = 6,000 \text{ horse-power (nearly).}$$

2. What size of solid shaft is needed to transmit 6,000 horse-power at 50 revolutions per minute if the shearing working strength of the material is 10,000 pounds per square inch?

We have merely to substitute in the first of the two formulas 16, and solve for d . Thus,

$$6,000 = \frac{10,000 \times d^3 \times 50}{321,000};$$

therefore
$$d^3 = \frac{6,000 \times 321,000}{10,000 \times 50} = 3,852;$$

or,
$$d = \sqrt[3]{3,852} = 15.68 \text{ inches.}$$

(A solid shaft of this diameter contains over 25% more material than the hollow shaft of example 1 preceding. There is therefore considerable saving of material in the hollow shaft.)

3. A solid shaft 4 inches in diameter transmits 200 horse-power while rotating at 200 revolutions per minute. What is the greatest shearing unit-stress in the shaft?

We have merely to substitute in the first of the equations 16, and solve for S_s . Thus,

$$200 = \frac{S_s \times 4^3 \times 200}{321,000};$$

or,
$$S = \frac{200 \times 321,000}{4^3 \times 200} = 5,016 \text{ pounds per square inch.}$$

EXAMPLES FOR PRACTICE.

1. What horse-power can a solid shaft 9.6 inches in diameter safely transmit at 50 revolutions per minute, if its shearing working strength is 10,000 pounds per square inch?

Ans. 1,378 horse-power.

2. What size of solid shaft is required to transmit 500 horse-power at 150 revolutions per minute, the shearing working strength of the material being 8,000 pounds per square inch.

Ans. 5.1 inches.

3. A hollow shaft whose outer diameter is 14 and inner 6.7 inches transmits 5,000 horse-power at 60 revolutions per minute. What is the value of the greatest shearing unit-stress in the shaft?

Ans. 10,273 pounds per square inch.

STIFFNESS OF RODS, BEAMS, AND SHAFTS.

The preceding discussions have related to the *strength* of

materials. We shall now consider principally the *elongation of rods, deflection of beams, and twist of shafts.*

95. Coefficient of Elasticity. According to Hooke's Law (Art. 9, p. 7), the elongations of a rod subjected to an increasing pull are proportional to the pull, provided that the stresses due to the pull do not exceed the elastic limit of the material. Within the elastic limit, then, the ratio of the pull and the elongation is constant; hence the ratio of the unit-stress (due to the pull) to the unit-elongation is also constant. This last-named ratio is called "coefficient of elasticity." If E denotes this coefficient, S the unit-stress, and s the unit-deformation, then

$$E = \frac{S}{s}. \quad (17)$$

Coefficients of elasticity are usually expressed in pounds per square inch.

The preceding remarks, definition, and formula apply also to a case of compression, provided that the material being compressed does not bend, but simply shortens in the direction of the compressing forces. The following table gives the *average* values of the coefficient of elasticity for various materials of construction:

TABLE G.
Coefficients of Elasticity.

Material.	Average Coefficient of Elasticity.
Steel.....	30,000,000 pounds per square inch.
Wrought iron.....	27,500,000 " " " "
Cast iron.....	15,000,000 " " " "
Timber.....	1,800,000 " " " "

The coefficients of elasticity for steel and wrought iron, for different grades of those materials, are remarkably constant; but for different grades of cast iron the coefficients range from about 10,000,000 to 30,000,000 pounds per square inch. Naturally the coefficient has not the same value for the different kinds of wood; for the principal woods it ranges from 1,600,000 (for spruce) to 2,100,000 (for white oak).

Formula 17 can be put in a form more convenient for use, as follows :

Let P denote the force producing the deformation; A the area of the cross-section of the piece on which P acts; l the length of the piece; and D the deformation (elongation or shortening).

Then

$$S = P \div A \text{ (see equation 1),}$$

and

$$s = D \div l \text{ (see equation 2).}$$

Hence, substituting these values in equation 17, we have

$$E = \frac{Pl}{AD}; \text{ or } D = \frac{Pl}{AE}. \quad (17')$$

The first of these two equations is used for computing the value of the coefficient of elasticity from measurements of a "test," and the second for computing the elongation or shortening of a given rod or bar for which the coefficient is known.

Examples. 1. It is required to compute the coefficient of elasticity of the material the record of a test of which is given on page 9.

Since the unit-stress S and unit-elongation s are already computed in that table, we can use equation 17 instead of the first of equations 17'. The elastic limit being between 40,000 and 45,000 pounds per square inch, we may use any value of the unit-stress less than that, and the corresponding unit-elongation.

Thus, with the first values given,

$$E = \frac{5,000}{0.00017} = 29,400,000.$$

With the second,

$$E = \frac{10,000}{0.00035} = 28,600,000.$$

This lack of constancy in the value of E as computed from different loads in a test of a given material, is in part due to errors in measuring the deformation, a measurement difficult to make. The value of the coefficient adopted from such a test, is the average of all the values of E which can be computed from the record.

2. How much will a pull of 5,000 pounds stretch a round steel rod 10 feet long and 1 inch in diameter?

We use the second of the two formulas 17'. Since $A = 0.7854 \times 1^2 = 0.7854$ square inches, $l = 120$ inches, and $E = 30,000,000$ pounds per square inch, the stretch is:

$$D = \frac{5,000 \times 120}{0.7854 \times 30,000,000} = 0.0254 \text{ inch.}$$

EXAMPLES FOR PRACTICE.

1. What is the coefficient of elasticity of a material if a pull of 20,000 pounds will stretch a rod 1 inch in diameter and 4 feet long 0.045 inch?

Ans. 27,000,000 pounds per square inch.

2. How much will a pull of 15,000 pounds elongate a round cast-iron rod 10 feet long and 1 inch in diameter?

Ans. 0.152 inch.

96. Temperature Stresses. In the case of most materials, when a bar or rod is heated, it lengthens; and when cooled, it shortens if it is free to do so. The **coefficient of linear expansion** of a material is the ratio which the elongation caused in a rod or bar of the material by a change of one degree in temperature bears to the length of the rod or bar. Its values for Fahrenheit degrees are about as follows:

For Steel, 0.0000065.

For Wrought iron, .0000067.

For Cast iron, .0000062.

Let K be used to denote this coefficient; t a change of temperature, in degrees Fahrenheit; l the length of a rod or bar; and D the change in length due to the change of temperature. Then

$$D = K t l. \quad (18)$$

D and l are expressed in the same unit.

If a rod or bar is confined or restrained so that it cannot change its length when it is heated or cooled, then any change in its temperature produces a stress in the rod; such are called **temperature stresses**.

Examples. 1. A steel rod connects two solid walls and is screwed up so that the unit-stress in it is 10,000 pounds per square inch. Its temperature falls 10 degrees, and it is observed that the walls have not been drawn together. What is the temperature stress produced by the change of temperature, and what is the actual unit-stress in the rod at the new temperature?

Let l denote the length of the rod. Then the change in length which would occur if the rod were free, is given by formula 18, above, thus:

$$D = 0.0000065 \times 10 \times l = 0.000065 l.$$

Now, since the rod could not shorten, it has a greater than normal length at the new temperature; that is, the fall in temperature has produced an effect equivalent to an elongation in the rod amounting to D , and hence a tensile stress. This tensile stress can be computed from the elongation D by means of formula 17. Thus,

$$S = E s;$$

and since s , the unit-elongation, equals

$$\frac{D}{l} = \frac{.0000065 l}{l} = .0000065,$$

$S = 30,000,000 \times .0000065 = 195.0$ pounds per square inch. This is the value of the temperature stress; and the new unit-stress equals

$$10,000 + 195.0 = 10,195 \text{ pounds per square inch.}$$

Notice that the unit temperature stresses are independent of the length of the rod and the area of its cross-section.

2. Suppose that the change of temperature in the preceding example is a rise instead of a fall. What are the values of the temperature stress due to the change, and of the new unit-stress in the rod?

The temperature stress is the same as in example 1, that is, 1,950 pounds per square inch; but the rise in temperature releases, as it were, the stress in the rod due to its being screwed up, and the final unit stress is

$$10,000 - 1,950 = 8,050 \text{ pounds per square inch.}$$

EXAMPLE FOR PRACTICE.

1. The ends of a wrought-iron rod 1 inch in diameter are fastened to two heavy bodies which are to be drawn together, the temperature of the rod being 200 degrees when fastened to the objects. A fall of 120 degrees is observed not to move them. What is the temperature stress, and what is the pull exerted by the rod on each object?

Ans. $\left\{ \begin{array}{l} \text{Temperature stress, 22,000 pounds per square inch.} \\ \text{Pull, 17,280 pounds.} \end{array} \right.$

97. Deflection of Beams. Sometimes it is desirable to know how much a given beam will deflect under a given load, or to design

a beam which will not deflect more than a certain amount under a given load. In Table B, page 53, Part I, are given formulas for deflection in certain cases of beams and different kinds of loading.

In those formulas, d denotes deflection; I the moment of inertia of the cross-section of the beam with respect to the neutral axis, as in equation 6; and E the coefficient of elasticity of the material of the beam (for values, see Art. 95).

In each case, the load should be expressed in pounds, the length in inches, and the moment of inertia in biquadratic inches; then the deflection will be in inches.

According to the formulas for d , the deflection of a beam varies inversely as the coefficient of its material (E) and the moment of inertia of its cross-section (I); also, in the first four and last two cases of the table, the deflection varies directly as the cube of the length (l^3).

Example. What deflection is caused by a uniform load of 6,400 pounds (including weight of the beam) in a wooden beam on end supports, which is 12 feet long and 6×12 inches in cross-section? (This is the safe load for the beam; see example 1, Art. 65.)

The formula for this case (see Table B, page 53) is

$$d = \frac{5 W l^3}{384 E I}.$$

Here $W = 6,400$ pounds; $l = 144$ inches; $E = 1,800,000$ pounds per square inch; and

$$I = \frac{1}{12} b a^3 = \frac{1}{12} 6 \times 12^3 = 864 \text{ inches}^4.$$

Hence the deflection is

$$d = \frac{5 \times 6,400 \times 144^3}{384 \times 1,800,000 \times 864} = 0.16 \text{ inch.}$$

EXAMPLES FOR PRACTICE.

1. Compute the deflection of a timber built-in cantilever 8×8 inches which projects 8 feet from the wall and bears an end load of 900 pounds. (This is the safe load for the cantilever, see example 1, Art. 65.)

Ans. 0.43 inch.

2. Compute the deflection caused by a uniform load of 40,000

pounds on a 42-pound 15-inch steel I-beam which is 16 feet long and rests on end supports.

Ans. 0.28 inch.

98. **Twist of Shafts.** Let Fig. 57 represent a portion of a shaft, and suppose that the part represented lies wholly between

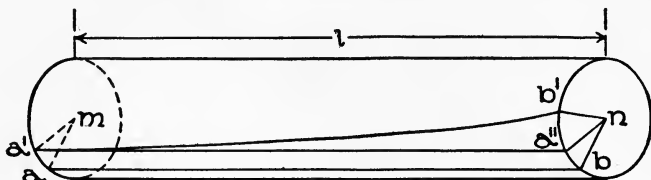

Fig. 57.

two adjacent pulleys on a shaft to which twisting forces are applied (see Fig. 54). Imagine two radii ma and nb in the ends of the portion, they being parallel as shown when the shaft is not twisted. After the shaft is twisted they will not be parallel, ma having moved to $m'a'$, and nb to $n'b'$. The angle between the two lines in their twisted positions ($m'a'$ and $n'b'$) is called the **angle of twist**, or **angle of torsion**, for the length l . If $a'a''$ is parallel to ab , then the angle $a''n'b'$ equals the angle of torsion.

If the stresses in the portion of the shaft considered do not exceed the elastic limit, and if the twisting moment is the same for all sections of the portion, then the angle of torsion a (in degrees) can be computed from the following:

For solid circular shafts,

$$a = \frac{584 Tl}{E' d^4} = \frac{36,800,000 Hl}{E' d^4 n}$$

For hollow circular shafts,

$$a = \frac{584 Tld}{E' (d^4 - d_1^4)} = \frac{36,800,000 Hl}{E' (d^4 - d_1^4) n}$$

(19)

Here T , l , d , d_1 , H , and n have the same meanings as in Arts. 93 and 94, and should be expressed in the units there used. The letter E' stands for a quantity called **coefficient of elasticity for shear**; it is analogous to the coefficient of elasticity for tension and compression (E), Art. 95. The values of E' for a few materials average about as follows (roughly $E' = \frac{2}{3} E$):

For Steel,	11,000,000	pounds per square inch.
For Wrought iron,	10,000,000	“ “ “ “
For Cast iron,	6,000,000	“ “ “ “

Example. What is the value of the angle of torsion of a steel shaft 60 feet long when transmitting 6,000 horse-power at 50 revolutions per minute, if the shaft is hollow and its outer and inner diameters are 16 and 8 inches respectively?

Here $l = 720$ inches; hence, substituting in the appropriate formula (19), we find that

$$\alpha = \frac{36,800,000 \times 6,000 \times 720}{11,000,000 \times (16^4 - 8^4) 50} = 4.7 \text{ degrees.}$$

EXAMPLE FOR PRACTICE.

Suppose that the first two pulleys in Fig. 54 are 12 feet apart; that the diameter of the shaft is 2 inches; and that $P_1 = 400$ pounds, and $a_1 = 15$ inches. If the shaft is of wrought iron, what is the value of the angle of torsion for the portion between the first two pulleys?

Ans. 3.15 degrees.

99. Non-elastic Deformation. The preceding formulas for elongation, deflection, and twist hold only so long as the greatest unit-stress does not exceed the elastic limit. There is no theory, and no formula, for non-elastic deformations, those corresponding to stresses which exceed the elastic limit. It is well known, however, that non-elastic deformations are not proportional to the forces producing them, but increase much faster than the loads. The value of the ultimate elongation of a rod or bar (that is, the amount of elongation at rupture), is quite well known for many materials. This elongation, for eight-inch specimens of various materials (see Art. 16), is :

For Cast iron,	about 1 per cent.
For Wrought iron (plates),	12 - 15 per cent.
For “ “ (bars),	20 - 25 “ “ .
For Structural steel,	22 - 26 “ “ .

Specimens of ductile materials (such as wrought iron and structural steel), when pulled to destruction, **neck down**, that is, diminish very considerably in cross-section at some place along the length of the specimen. The decrease in cross-sectional area

is known as **reduction of area**, and its value for wrought iron and steel may be as much as 50 per cent.

RIVETED JOINTS.

100. Kinds of Joints. A **lap joint** is one in which the plates or bars joined overlap each other, as in Fig. 58, *a*. A **butt joint** is one in which the plates or bars that are joined butt against each other, as in Fig. 58, *b*. The thin side plates on butt joints

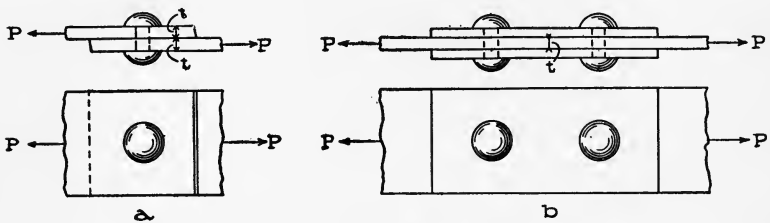

Fig. 58.

are called **cover-plates**; the thickness of each is always made not less than one-half the thickness of the **main plates**, that is, the plates or bars that are joined. Sometimes butt joints are made with only one cover-plate; in such a case the thickness of the cover-plate is made not less than that of the main plate.

When wide bars or plates are riveted together, the rivets are placed in rows, always parallel to the "seam" and sometimes also perpendicular to the seam; but when we speak of a row of rivets, we mean a row parallel to the seam. A lap joint with a single row of rivets is said to be **single-riveted**; and one with two rows of rivets is said to be **double-riveted**. A butt joint with two rows of rivets (one on each side of the joint) is called "single-riveted," and one with four rows (two on each side) is said to be "double-riveted."

The distance between the centers of consecutive holes in a row of rivets is called **pitch**.

101. Shearing Strength, or Shearing Value, of a Rivet. When a lap joint is subjected to tension (that is, when *P*, Fig. 58, *a*, is a pull), and when the joint is subjected to compression (when *P* is a push), there is a tendency to cut or shear each rivet along the surface between the two plates. In butt joints with two cover-

plates, there is a tendency to cut or shear each rivet on two surfaces (see Fig. 58, *b*). Therefore the rivets in the lap joint are said to be in **single shear**; and those in the butt joint (two covers) are said to be in **double shear**.

The "shearing value" of a rivet means the resistance which it can safely offer to forces tending to shear it on its cross-section. This value depends on the area of the cross-section and on the working strength of the material. Let d denote the diameter of the cross-section, and S_s the shearing working strength. Then, since the area of the cross-section equals $0.7854 d^2$, the shearing strength of one rivet is :

For single shear,	$0.7854 d^2 S_s .$
For double shear,	$1.5708 d^2 S_s .$

102. Bearing Strength, or Bearing Value, of a Plate. When a joint is subjected to tension or compression, each rivet presses against a part of the sides of the holes through which it passes. By "bearing value" of a plate (in this connection) is meant the pressure, exerted by a rivet against the side of a hole in the plate, which the plate can safely stand. This value depends on the thickness of the plate, on the diameter of the rivet, and on the compressive working strength of the plate. Exactly how it depends on these three qualities is not known; but the bearing value is always computed from the expression $t d S_c$, wherein t denotes the thickness of the plate; d , the diameter of the rivet or hole; and S_c , the working strength of the plate.

103. Frictional Strength of a Joint. When a joint is subjected to tension or compression, there is a tendency to slippage between the faces of the plates of the joint. This tendency is overcome wholly or in part by frictional resistance between the plates. The frictional resistance in a well-made joint may be very large, for rivets are put into a joint hot, and are **headed or capped** before being cooled. In cooling they contract, drawing the plates of the joint tightly against each other, and producing a great pressure between them, which gives the joint a correspondingly large frictional strength. It is the opinion of some that all well-made joints perform their service by means of their frictional strength; that is to say, the rivets act only by pressing the plates together and are not under shearing stress, nor

are the plates under compression at the sides of their holes. The "frictional strength" of a joint, however, is usually regarded as uncertain, and generally no allowance is made for friction in computations on the strength of riveted joints.

104. Tensile and Compressive Strength of Riveted Plates. The holes punched or drilled in a plate or bar weaken its tensile strength, and to compute that strength it is necessary to allow for the holes. By **net section**, in this connection, is meant the smallest cross-section of the plate or bar; this is always a section along a line of rivet holes.

If, as in the foregoing article, t denotes the thickness of the plates joined; d , the diameter of the holes; n_1 , the number of rivets in a row; and w , the width of the plate or bar; then the net section = $(w - n_1d) t$.

Let S_t denote the tensile working strength of the plate; then the strength of the unriveted plate is wtS_t , and the reduced tensile strength is $(w - n_1d) t S_t$.

The compressive strength of a plate is also lessened by the presence of holes; but when they are again filled up, as in a joint, the metal is replaced, as it were, and the compressive strength of the plate is restored. No allowance is therefore made for holes in figuring the compressive strength of a plate.

105. Computation of the Strength of a Joint. The strength of a joint is determined by either (1) the shearing value of the rivets; (2) the bearing value of the plate; or (3) the tensile strength of the riveted plate if the joint is in tension. Let P_s denote the strength of the joint as computed from the shearing values of the rivets; P_c , that computed from the bearing value of the plates; and P_t , the tensile strength of the riveted plates. Then, as before explained,

$$\left. \begin{aligned} P_t &= (w - n_1d) t S_t; \\ P_s &= n_2 \cdot 0.7854 d^2 S_s; \text{ and} \\ P_c &= n_3 t d S_c; \end{aligned} \right\} \quad (20)$$

n_2 denoting the total number of rivets in the joint; and n_3 denoting the total number of rivets in a lap joint, and one-half the number of rivets in a butt joint.

Examples. 1. Two half-inch plates $7\frac{1}{2}$ inches wide are con-

ned by a single lap joint double-riveted, six rivets in two rows. If the diameter of the rivets is $\frac{3}{4}$ inch, and the working strengths are as follows: $S_t = 12,000$, $S_s = 7,500$, and $S_c = 15,000$ pounds per square inch, what is the safe tension which the joint can transmit?

Here $n_1 = 3$, $n_2 = 6$, and $n_3 = 6$; hence

$$P_t = (7\frac{1}{2} - 3 \times \frac{3}{4}) \times \frac{1}{2} \times 12,000 = 31,500 \text{ pounds;}$$

$$P_s = 6 \times 0.7854 \times (\frac{3}{4})^2 \times 7,500 = 19,880 \text{ pounds;}$$

$$P_c = 6 \times \frac{1}{2} \times \frac{3}{4} \times 15,000 = 33,750 \text{ pounds.}$$

Since P_s is the least of these three values, the strength of the joint depends on the shearing value of its rivets, and it equals 19,880 pounds.

2. Suppose that the plates described in the preceding example are joined by means of a butt joint (two cover-plates), and 12 rivets are used, being spaced as before. What is the safe tension which the joint can bear?

Here $n_1 = 3$, $n_2 = 12$, and $n_3 = 6$; hence, as in the preceding example,

$$P_t = 31,500; \text{ and } P_c = 33,750 \text{ pounds; but}$$

$$P_s = 12 \times 0.7854 \times (\frac{3}{4})^2 \times 7,500 = 39,760 \text{ pounds.}$$

The strength equals 31,500 pounds, and the joint is stronger than the first.

3. Suppose that in the preceding example the rivets are arranged in rows of two. What is the tensile strength of the joint?

Here $n_1 = 2$, $n_2 = 12$, and $n_3 = 6$; hence, as in the preceding example,

$$P_s = 39,760; \text{ and } P_c = 33,750 \text{ pounds; but}$$

$$P_t = (7\frac{1}{2} - 2 \times \frac{3}{4}) \frac{1}{2} \times 12,000 = 36,000 \text{ pounds.}$$

The strength equals 33,750 pounds, and this joint is stronger than either of the first two.

EXAMPLES FOR PRACTICE.

Note. Use working strengths as in example 1, above.

$S_t = 12,000$, $S_s = 7,500$, and $S_c = 15,000$ pounds per square inch.

1. Two half-inch plates 5 inches wide are connected by a lap joint, with two $\frac{3}{4}$ -inch rivets in a row. What is the safe strength of the joint?

Ans. 6,625 pounds.

2. Solve the preceding example supposing that four $\frac{3}{4}$ -inch rivets are used, in two rows.

Ans. 13,250 pounds.

3. Solve example 1 supposing that three 1-inch rivets are used, placed in a row lengthwise of the joint.

Ans. 17,670 pounds.

4. Two half-inch plates 5 inches wide are connected by a butt joint (two cover-plates), and four $\frac{3}{4}$ -inch rivets are used, in two rows. What is the strength of the joint?

Ans. 11,250 pounds.

106. Efficiency of a Joint. The ratio of the strength of a joint to that of the solid plate is called the "efficiency of the joint." If ultimate strengths are used in computing the ratio, then the efficiency is called **ultimate efficiency**; and if working strengths are used, then it is called **working efficiency**. In the following, we refer to the latter. An efficiency is sometimes expressed as a per cent. To express it thus, multiply the ratio *strength of joint* \div *strength of solid plate*, by 100.

Example. It is required to compute the efficiencies of the joints described in the examples worked out in the preceding article.

In each case the plate is $\frac{1}{2}$ inch thick and $7\frac{1}{2}$ inches wide; hence the tensile working strength of the solid plate is

$$7\frac{1}{2} \times \frac{1}{2} \times 12,000 = 45,000 \text{ pounds.}$$

Therefore the efficiencies of the joints are :

$$(1) \quad \frac{19,880}{45,000} = 0.44, \text{ or } 44 \text{ per cent;}$$

$$(2) \quad \frac{31,500}{45,000} = 0.70, \text{ or } 70 \text{ per cent;}$$

$$(3) \quad \frac{33,750}{45,000} = 0.75, \text{ or } 75 \text{ per cent.}$$

INDEX

	Page
Angle of torsion.....	116
Angle of twist.....	116
Applications of first beam formula.....	59
Beam formula	
first.....	59
second.....	73
Beams.....	19
deflection of.....	114
stiffness of.....	110
Bearing strength of a plate.....	119
Bending moment.....	23, 32
maximum.....	40
Brick, ultimate strength of.....	15
Broken straight-line formula.....	101
Built-up sections, moment of inertia of.....	49
Butt joint.....	118
Cast iron	
in tension.....	13
in compression.....	15
Center of gravity of an area.....	41
Center of gravity of built-up sections.....	44
Centrally loaded column.....	88
Coefficient of elasticity.....	111
for shear.....	116
Coefficient of linear expansion.....	113
Column formulas	
graphical representation of.....	93
Rankine's.....	88
Column loads, kinds of.....	88
Columns	
classes of.....	86
cross-sections of.....	86
design of.....	102
end conditions of.....	85
strength of.....	85
Combination column formulas.....	94
Combined flexural and direct stress.....	83
Compression, materials in.....	13
Compressive strength of riveted plates.....	120
Continuous beam.....	19

	Page
Cover-plates.....	118
Deflection of beams.....	114
Deformation.....	4
Design of	
columns.....	102
timber beams.....	76
Direct stress.....	79
Double shear.....	119
Eccentrically loaded.....	88
Efficiency of a joint.....	122
Elastic limit.....	5
Elasticity.....	4
End conditions of column.....	85
Euler formulas.....	94
External shear.....	23
Factor of safety.....	8
Fibre stresses.....	55, 57
First beam formula.....	59
Flexural stress.....	79
Flexure and compression.....	81
Flexure and tension.....	79
Formula for power which shaft can transmit.....	109
Formula for strength of shaft.....	107
Frictional strength of joint.....	119
Graphical representation of column formulas.....	93
Hooke's law.....	5
Horizontal shear.....	75
Inclined forces.....	54
Joint	
efficiency of.....	122
frictional strength of.....	119
Kinds of loads and beams.....	52, 79
Kinds of stress.....	2, 55
Lap joint.....	118
Laws of strength of beams.....	71
Linear expansion, coefficient of.....	113
Longitudinal forces.....	54
Main plates.....	118
Materials	
in compression.....	13
in shear.....	15
in tension.....	11
Maximum bending moment.....	40
Maximum shear.....	31
Metals in shear.....	16
Modulus of rupture.....	72
Moment diagrams.....	36
Moment of a force.....	16

	Page
Moment of inertia.....	46
of built-up sections.....	49
of a rectangle.....	48
unit of.....	47
Moments, principle of.....	17
Neutral axis.....	54
Neutral line.....	54
Neutral surface.....	54
Non-elastic deformation.....	117
Notation.....	24, 33
Parabola-Euler formulas.....	98
Posts.....	85
Principle of moments.....	17
applied to areas.....	42
Radius of gyration.....	86
Rankine's column formula.....	88
Reactions of supports.....	16
Rectangle, moment of inertia of.....	48
Reduction formula.....	48
Resisting moment.....	57, 107
value of.....	58
Resisting shear.....	73
Restrained beam.....	19
Rivet, shearing strength of.....	118
Riveted joints.....	118
Rods, stiffness of.....	110
Rule of signs.....	23, 32
Safe load of a beam.....	71
Safe strength of a beam.....	71
Second beam formula.....	73
Section modulus.....	59
Shafts	
stiffness of.....	110
strength of.....	105
twist of.....	116
twisting moment of.....	105
Shear diagrams.....	27
Shear stress.....	2
Shearing strength of rivet.....	118
Shears, unit for.....	24
Signs, rule of.....	23, 32
Simple beam.....	19
Simple stress.....	1
Single shear.....	119
Steel in compression.....	14
Steel in tension.....	12
Stiffness of rods, beams, and shafts.....	110
Stone, ultimate strength of.....	15

	Page
Straight-line formulas.....	94
Strength of beams.....	52
laws of.....	71
Strength of columns.....	85
Strength of joint, computation of.....	120
Strength of shafts.....	105
Stress, kinds of.....	2
Stress-deformation diagram.....	6
Struts.....	85
Tables	
bending moment.....	53
coefficients of elasticity.....	111
deflection.....	53
factors of safety.....	10
maximum shear, values of.....	53
mild steel columns, data for.....	95, 99
moduli of rupture.....	72
moment diagrams.....	53
moments of inertia.....	52
properties of standard I-beams.....	70
radii of gyration.....	52
section moduli.....	52
shear diagrams.....	53
Temperature stresses.....	113
Tensile strength of riveted plates.....	120
Tension, materials in.....	11
Timber	
in compression.....	14
in shear.....	15
in tension.....	11
Timber beams, design of.....	76
Torsional stress.....	106
Transverse forces.....	52
Twist of shafts.....	116
Twisting moment of shaft.....	105
Ultimate strength.....	6
Unit-deformation.....	4
Unit of moment of inertia.....	47
Unit-stress.....	3
Units.....	33
Units for shears.....	24
Value of resisting moment.....	58
Wrought-iron	
in compression.....	14
in tension.....	12
Working strength.....	8
Working stress.....	8



**THIS BOOK IS DUE ON THE LAST DATE
STAMPED BELOW**

**AN INITIAL FINE OF 25 CENTS
WILL BE ASSESSED FOR FAILURE TO RETURN
THIS BOOK ON THE DATE DUE. THE PENALTY
WILL INCREASE TO 50 CENTS ON THE FOURTH
DAY AND TO \$1.00 ON THE SEVENTH DAY
OVERDUE.**

OCT 10 1941 A.	
NOV 6 1941 M.	
	LD 21-100m-7,'40 (6936s)

929

6KC a

100 vH

TA405

N74

382946

Maurer

UNIVERSITY OF CALIFORNIA LIBRARY

